

**Instruction manual
for ribbing attachment
Model KR-710**

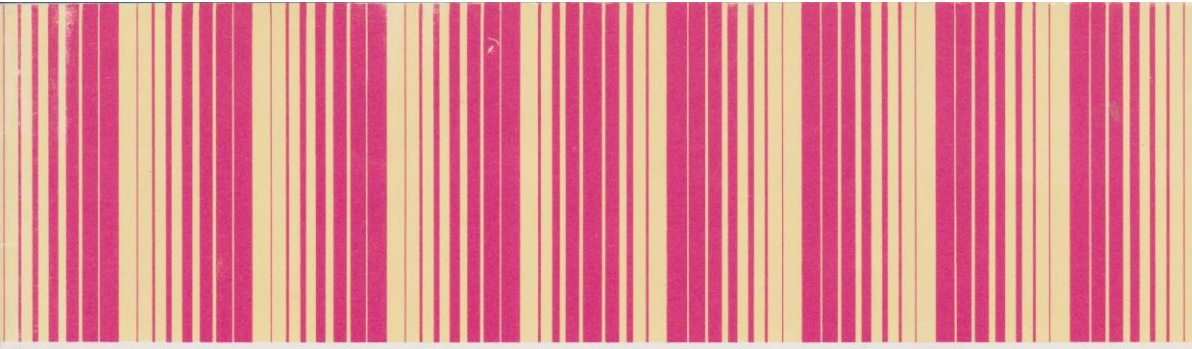

**Instruction manual
for ribbing attachment
Model KR-710**



SPECIAL INSTRUCTIONS FOR KR-120 RIBBING ATTACHMENT

The illustrations throughout this manual are of the KR-710, but bearing in mind the slight differences between models this manual is valid for both models.

The accessories list is for the KR-710 only.

The fine knitting bar is not included for the KR-120.

1/1 × 2/2 needle pusher is included instead of 1/2 × 2/2 needle pusher.

The Set screws and Extension rail holders are not included into the accessories for KR-120.

Please note that the model KR-120 is a fine gauge ribbing attachment, therefore please adjust the tension number as follows ;

Yarn	Slide lever	Pattern			
		1×1 Rib	2×2 Rib	Full needle	Circular
Super fine	I	0 ~ 2	2 ~ 4	3 ~ 5	6
	II	3 ~ 4		5 ~ 7	
Fine (ex.2ply)	I	2 ~ 3	3 ~ 4	3 ~ 4	6
	II	4 ~ 5			
Medium fine (ex.3ply)	I	3 ~ 5	3 ~ 5	5 ~ 7	7
	II	5 ~ 7			
Medium(ex.4ply)	I	4 ~ 6	5 ~ 7		8

You may change the angle of the yarn tension unit.
(See on page 6)

Name of parts

1

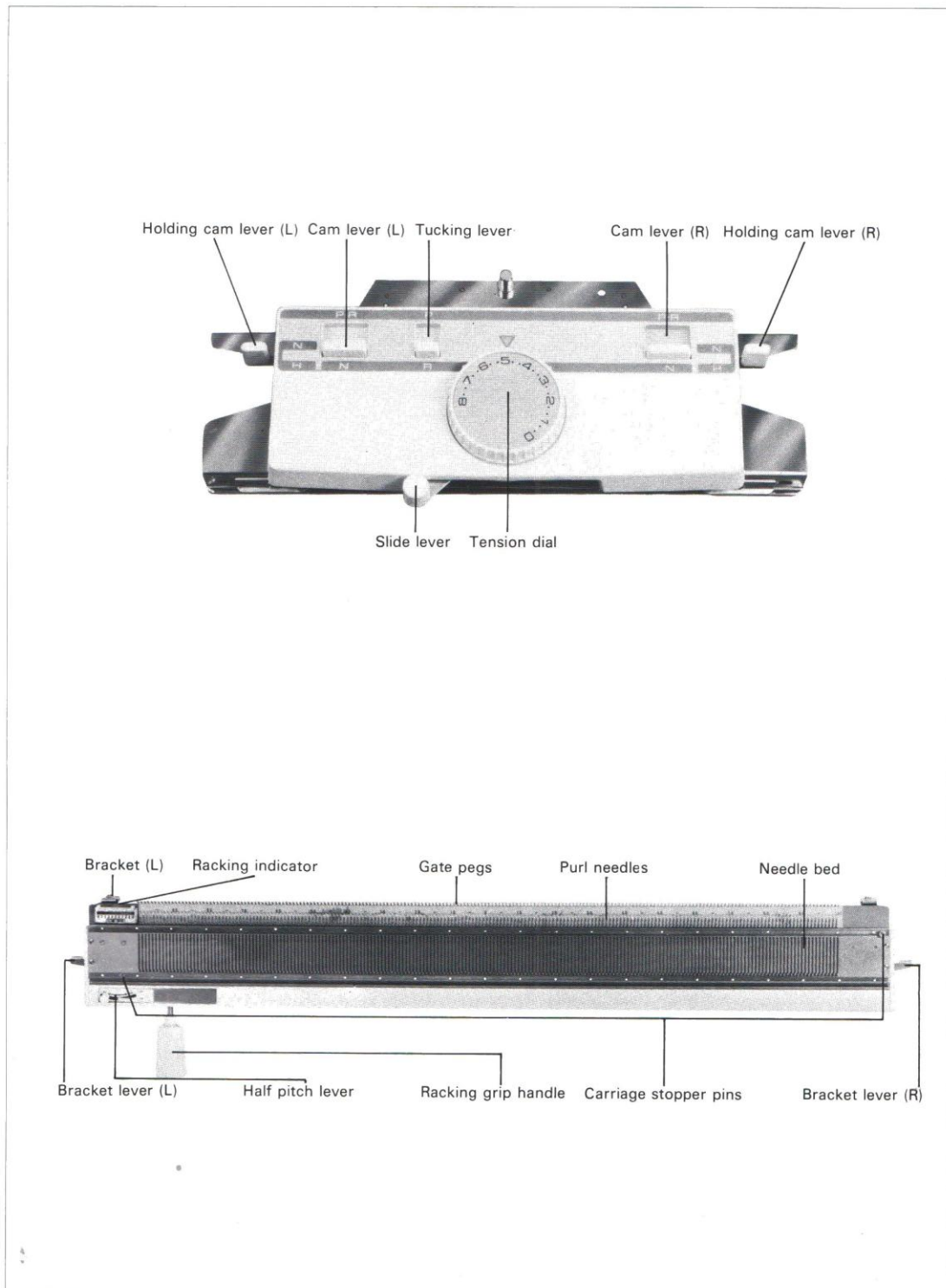

Accessories

2



Connecting arm assembly



Needle presser brush, R & L



Table clamps



Cast on Comb, long
short

Fine knitting bar



Wire-loop type weight hangers



Claw type weight hangers



Spanner



Work hook



Spare needles



Case



Transfer needle



$\frac{1}{2} \times \frac{3}{2}$ needle pusher



Large weights



Small weights

OPTIONAL PARTS



Set screw



Extension rail holder
for KH-588.

Setting up your ribber to the knitter

3

1. Take the table clamps out of the accessories box. Raise the front of the knitter, insert the head of screw into the aperture. Press the head of screw upwards and fasten the knob.

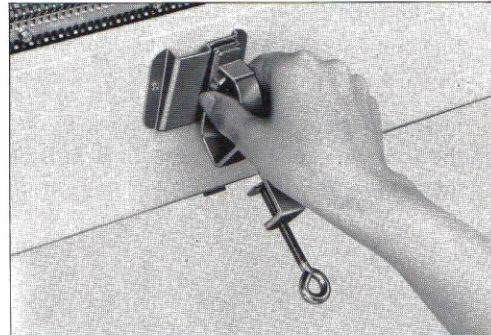

1

Secure the knitter onto a flat table using the Table clamps provided as an accessory for the ribber.

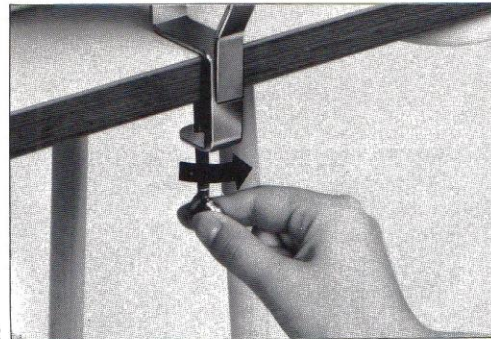

2

- 2 Remove the thumb screws from the brackets on both sides of the ribber.

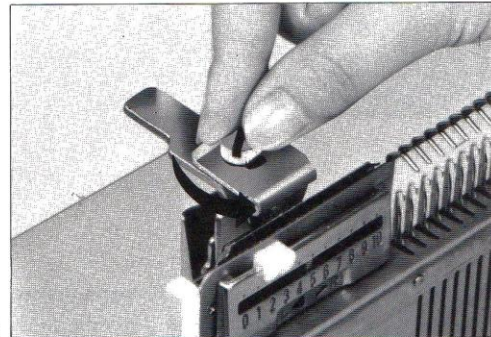

3

3. Insert the Grip shaft into the Racking grip shaft holer, and turning the grip handle, push it in until you hear the "click".

* After setting the grip handle, please check the working of the racking grip handle by turning it.

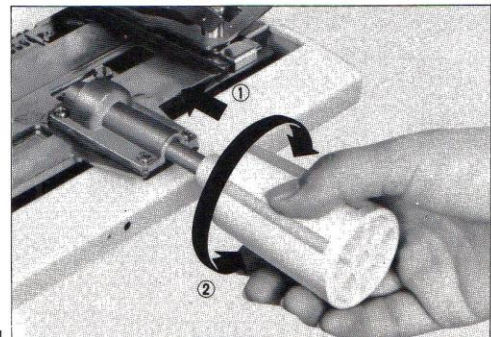

4

4. Holding the ribber with both hands so that the gate pegs of the ribber are up and the purl needle butts are toward you.

Insert the lower lip of right bracket beneath the knitter bed as far as it will go, then insert the left bracket.

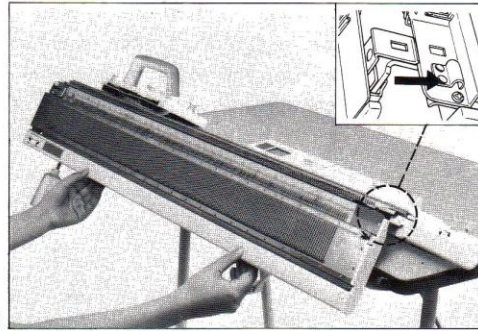

5. Using the Spanner, put the thumb screws to both brackets of the ribber.

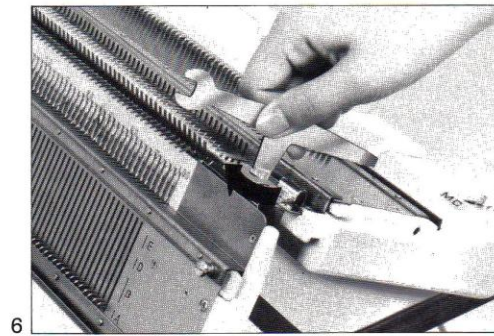

6. Place the rear foot of the KR carriage into left end of the rear rail of the needle bed, and keeping off the front foot from the front rail, move the KR carriage to right as shown in the photograph.

*The KR carriage is packed in an accessories box.

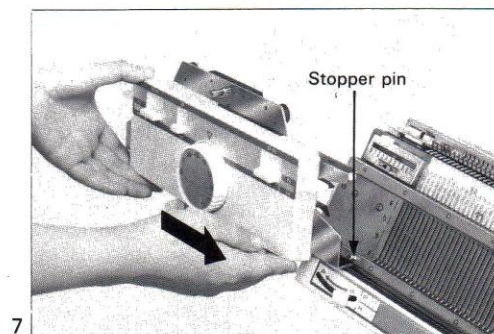

7. Set the front foot of the KR carriage to the front rail of the needle bed.
Please check whether the KR carriage moves on the needle bed smoothly.

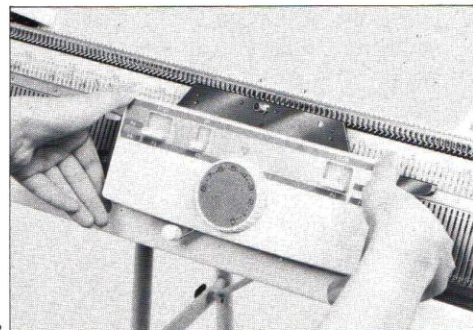

8

8. Loosen both Thumb screws of KH carriage and fit the Connecting arm securely.
Then fasten the screws.

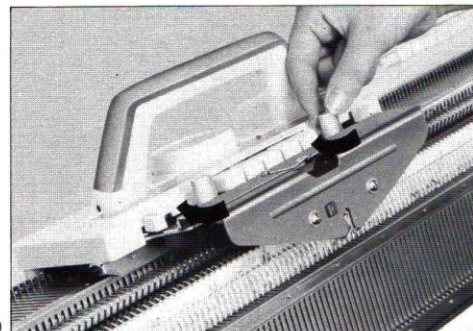

9

9. Move the KH carriage toward the KR carriage slowly so that both carriages connect with the connecting arm automatically.

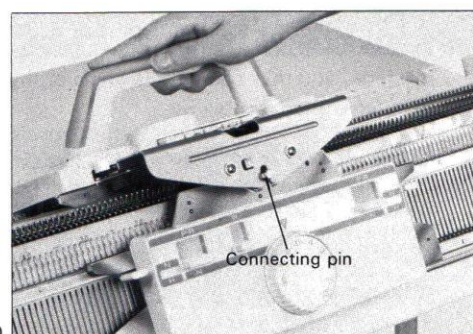

10

10. Lower the reinforcing arm of bracket, and place the flat part of arm on the table.

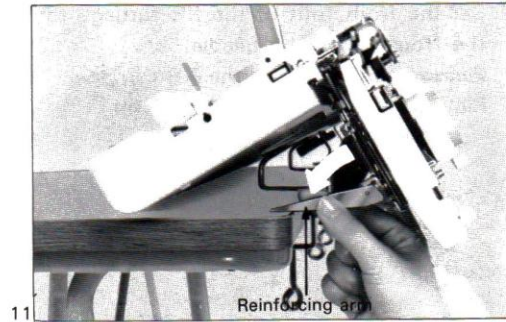

11

11. Using the clamps of KH, fasten the arm to the table.

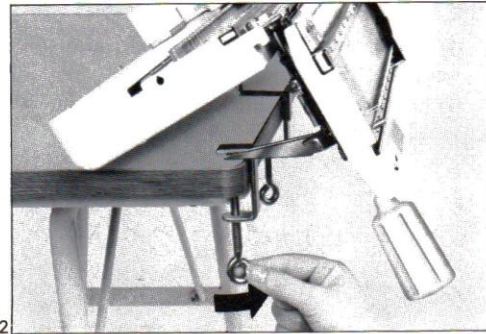

12

12. Set up the Yarn tension unit.

*In case the knitter is push button knitting machine, you may change the angle of the yarn tension unit as follows ;

- a. Take off the head of yarn tension unit and put it to the rod reversely.

*For the model KH-588, you cannot change the angle. Therefore, please use the yarn tension unit without changes.

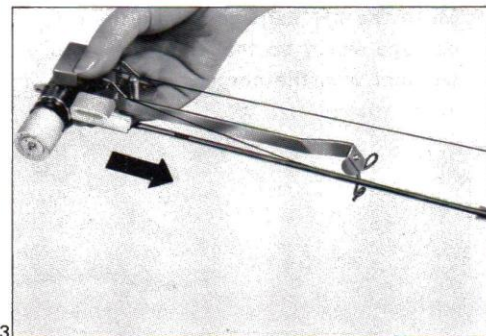

13

b. Turn back the "Take-up springs" as far as they will go.

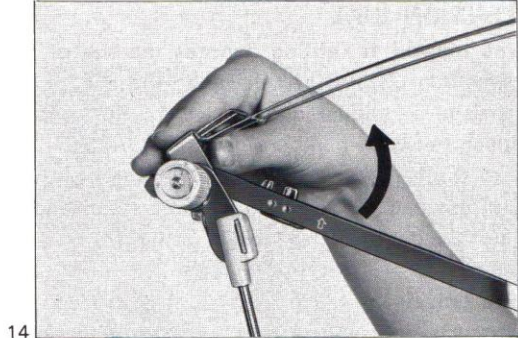

c. Turn the Rear yarn guide opposite to the side on which the Rear yarn guide is set when you use the knitter without attaching the ribber.

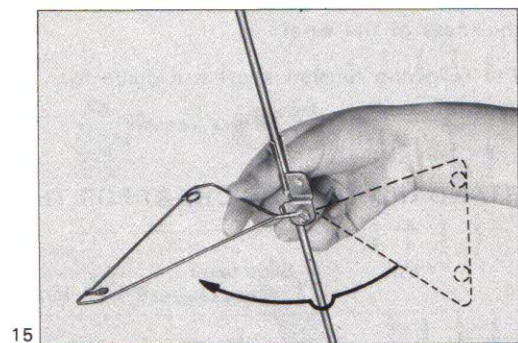

d. Insert the end of the rod into the stand hole at the center of the machine.

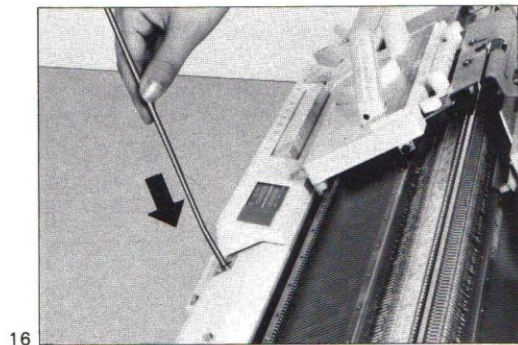

13. Now you have finished setting up the ribber to the knitter.

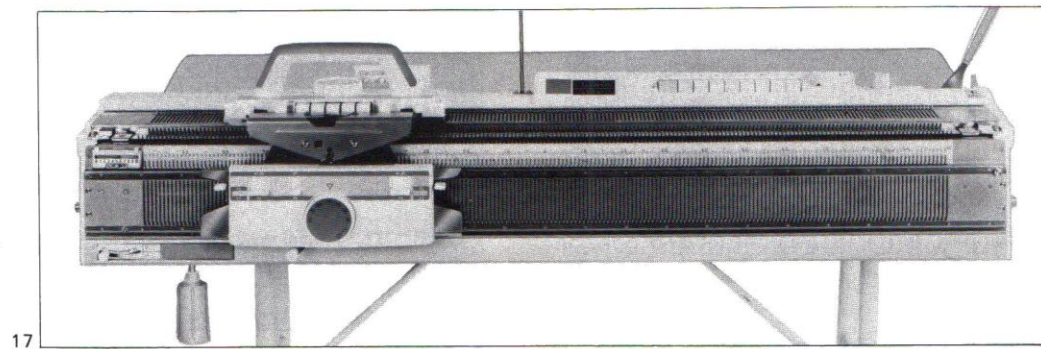

Here are a few important points to remember before you start knitting

8

TENSION DIAL

The tension in knitting denotes the size of the stitch. The tension dial on the KR carriage is graduated from "0" to "8", each space between numbers being subdivided into three parts. The figure "0" denotes the tightest tension, i.e. the smallest stitch and the "8" denotes the loosest or largest stitch.

The tension at which a garment is knitted depends not only on personal taste, but also on the type of garment required and the thickness of the wool.

The following tension chart is a guide for your reference.

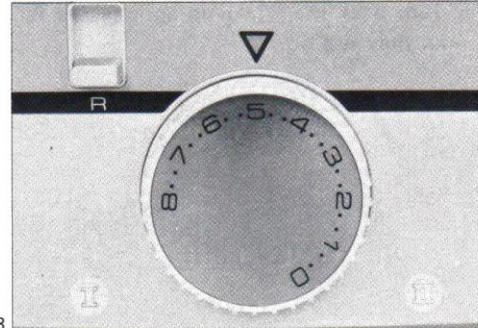

18

STANDARD TENSION CHART FOR THE COMBINATION OF KH AND KR

Yarn	Slide lever	Pattern			
		1×1 Rib	2×2 Rib	Full needle	Circular
Fine (ex.2ply)	I	/	/	/	3 ~ 4
	II	0 ~ 1	0 ~ 2	1 ~ 2	3 ~ 4
Medium(ex.3ply)	I	0 ~ 1	1 ~ 3	1 ~ 2	4 ~ 5
	II	3 ~ 5	3 ~ 5	2 ~ 4	4 ~ 5
Medium(ex.4ply)	I	0 ~ 2	2 ~ 4	2 ~ 4	5 ~ 6
	II	3 ~ 5	3 ~ 6	3 ~ 5	6 ~ 7
Bulky (ex.5ply)	I	5 ~ 8	5 ~ 8	/	6 ~ 8

19

SLIDE LEVER

The slide lever has two positions, I and II. If a firm automatic cast-on edge is required on ply up to 4 ply, use Slide lever position II. Position I is for thicker ply.

Elasticity and firmness of fabric is also determined by Slide lever position.

Position I is for a softer result and position II for a firm one.

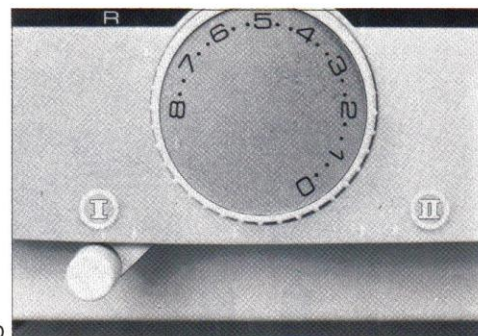

20

NEEDLE POSITION

There are 4 positions on the needle bed of the ribber.

Position A : Resting or non-knitting position.
(against the base of the needle grooves.)

Position B : Knitting or working position.

Position D : When the needles are brought in this position from the position E, they will automatically back to the position B by operation of the carriage.

Position E : Holding or partial knitting position.

HALF PITCH LEVER

Half pitch lever is on the left end below the needle bed. Two positions of the Half pitch lever are shown on the indicating plate as P and H.

Position P : Plain needles and purl needles directly opposite to each other.

Position H : Purl needles are halfway between two plain needles.

RACKING GRIP HANDLE

Racking grip handle is used for making the "Racking patterns" and "Zigzag patterns". The racking position is indicated on the racking indicator. By turning the Grip handle, ribber bed is moved right or left. Normally, set the indicator to No. 5 which shows centre position.

The two cursors on the indicator plate are used as an index of the racking range. The arrow head indicates the direction of racking movement.

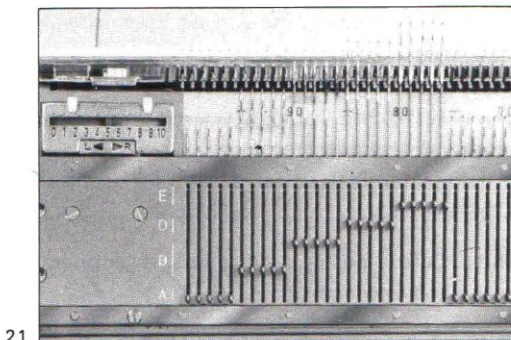

21

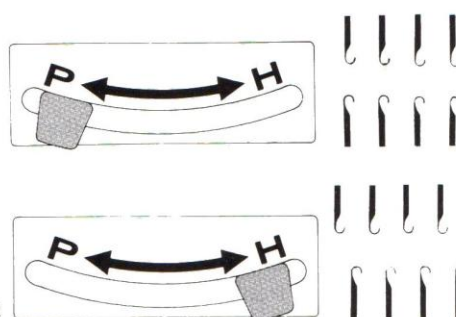

22

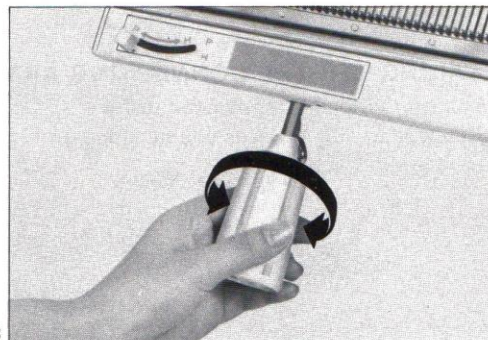

23

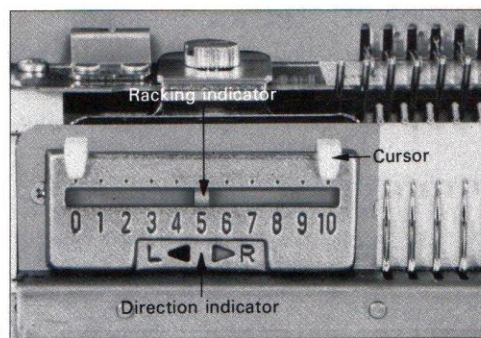

24

BRACKET LEVER

The bracket lever is used to let down the ribber.

With both thumbs, push down the levers of the bracket, the ribber will come down one step.

This position is used for picking up dropped stitches.

Note : Before pushing the levers, disconnect the carriage.

Push down the levers again and the ribber will come down one more step. At this position the ribber is at rest and single bed knitting work can be done without removing the ribber.

To return to working position, lift up the ribber with both hands as high as it will go until it stays in position without holding.

DISCONNECTING THE CARRIAGE

By pressing the connecting hook release button, left up the front of the KH carriage so that you can disconnect the carriage.

TAKING OFF THE CONNECTING ARM

Loosen the thumb screws and pull the Connecting arm towards you by lifting arm up slightly.

TAKING OFF THE KR CARRIAGE

After disconnecting the KR carriage from the KH carriage, move the KR carriage to left end of the needle bed by keeping off the front foot from the needle bed as shown in the photograph.

IF THE CARRIAGE SHOULD JAM DURING KNITTING, PLEASE REFER TO PAGE 38 TO RELEASE IT.

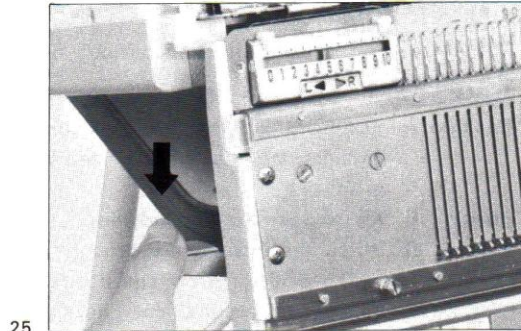

25

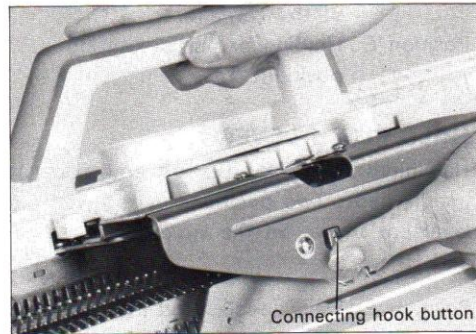

26

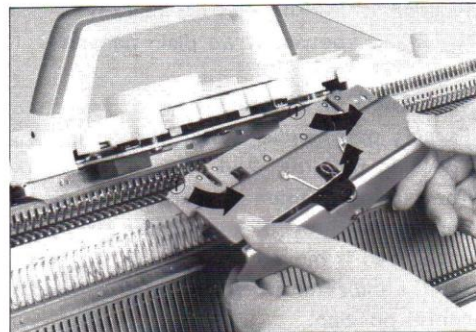

27

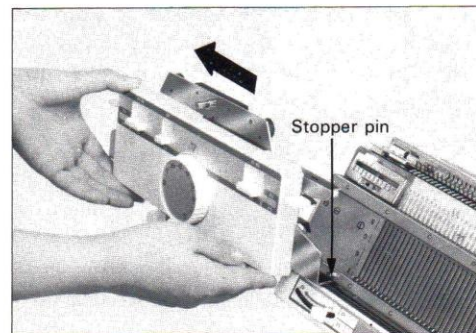

28

How to use the accessories

1. Cast-on comb

Cast-on comb is used for casting-on the first stitches which is the selvedge of the knitting. Choose long or small comb depending on the knitting width.

2. Weights

Number of weights to be used depends on the width of knitting and pattern. Hang the weights on the cast-on comb so that they hold the knitting work in balance.

3. Wire-loop type weight hangers

The wire-loop type weight hangers are used for hanging small weights to give tension to the edges of the knitting work and also used as a small cast-on comb for casting-on work of less than 20 stitches.

4. Work hook

The hook is used to pick up dropped stitches.

5. Claw-type weight hangers

The claw type weight hangers are used to hang the small weights to give tension to the edge of the knitting work.

6. Needle presser brushes

When the "TUCK" buttons on the KH carriage are depressed for the pattern, put the Needle presser brush (right and left) onto the carriage by thumb screws.

7. Fine knitting bar

The fine knitting bar is used only for knitting the thinner yarn at the tension number 0~2.

Insert the bar from the end of the KH needle bed as shown in the photograph and illustration.

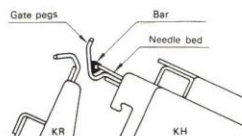

33

Standard weights chart

No. of stitches	Large weight	Small weight
~ 50	1	—
50 ~ 100	2	—
100 ~ 150	3	2
150 ~ 200	4	2

29

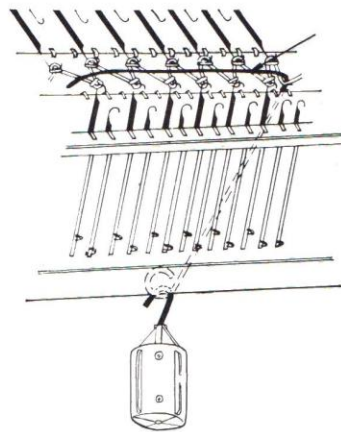

30

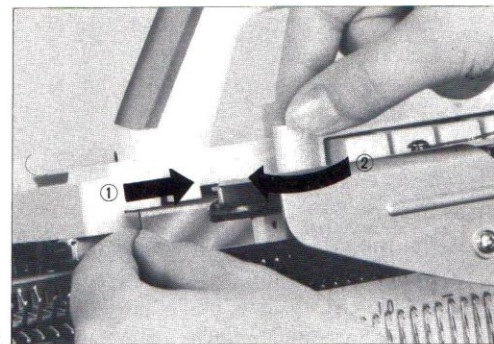

31

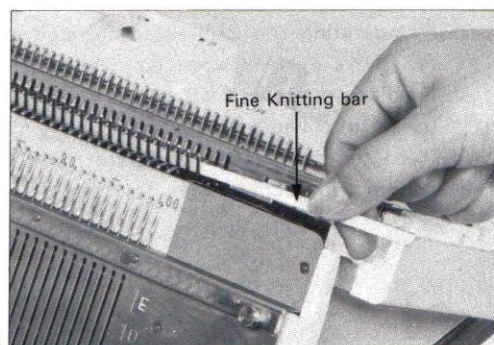

32

How to Knit 1 × 1 rib

12

1 × 1 rib is most widely used for waist bands in sweaters, cuffs, collars, pockets and for many other decorative purposes.

The rib is produced by having knit stitch over knit stitch and purl stitch over purl stitch, in vertical lines, and is soft and elastic. In the following example, medium thickness wool is used for the practice.

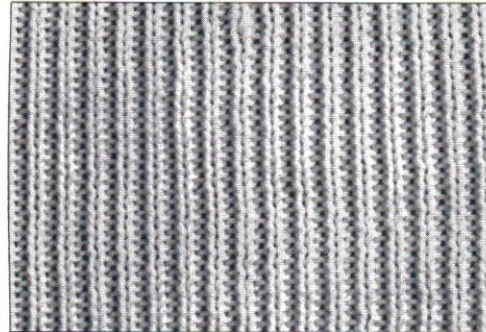

34

CASTING-ON FOR 1 × 1 RIB

1. Setting of carriage

Carriage (KH)

Change knob : N
Tension dial : O
Holding cam lever : (L) I, (R) I
Pattern selector button: PLAIN

Carriage (KR)

Slide lever : II
Tension dial : O
Cam lever : (L) N, (R) N
Tucking lever : R
Holding cam lever : (L) N, (R) N

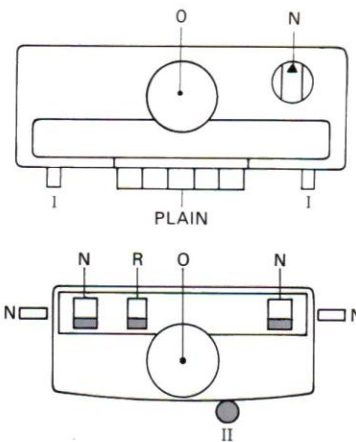

35

2. Needle arrangement

- Set the half pitch lever on "P".
- By using 1/1 needle pusher, arrange the plain needles and purl needles in position B of each bed. (See fig. 37.)
Note: Both end needles must be plain needles.
- By operating the connected carriage a few times over all arranged needles, the needles on KH and KR needle beds will be set in a line on position B.
- Place the connected carriage at right end of the needle beds.

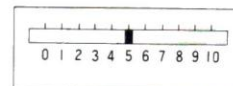
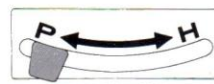

36



37



3. First row knitting

- a. Thread the yarn into the Yarn tension unit, and hold the end of yarn as shown in the Fig. 38.

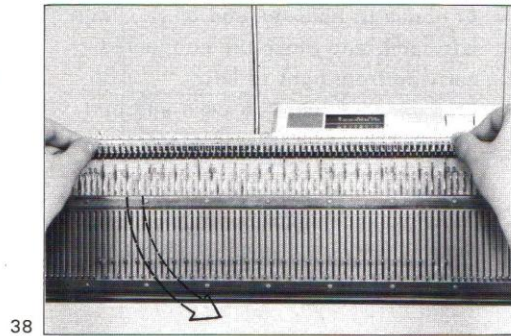

38

- b. Pass the yarn between both gate pegs, and catch the end of yarn underneath with left hand.

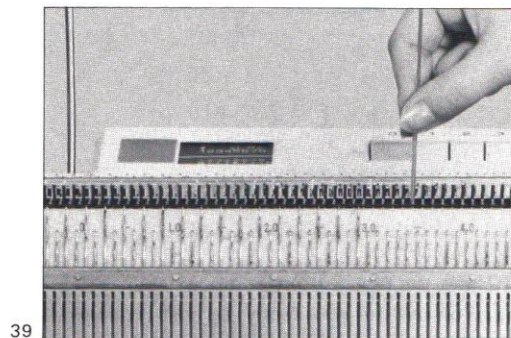

39

- c. Hold the yarn with right hand (continue to hold the end of yarn with left hand), pass to the yarn feeder. (see Fig. 40.)

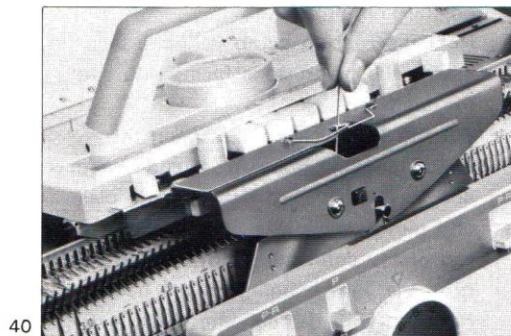

40

- d. Pass the yarn into the yarn feeder securely.

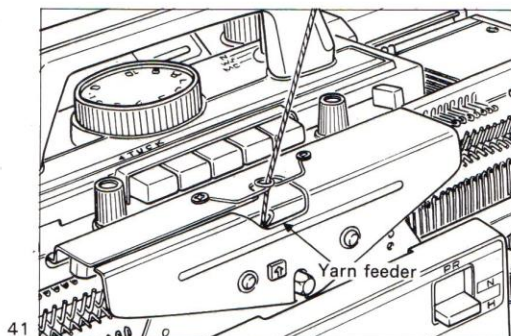

41

- e. Continue to hold the end of yarn with left hand, and move the connected carriage from right to left.
(The yarn will hang on plain and purl needles.)

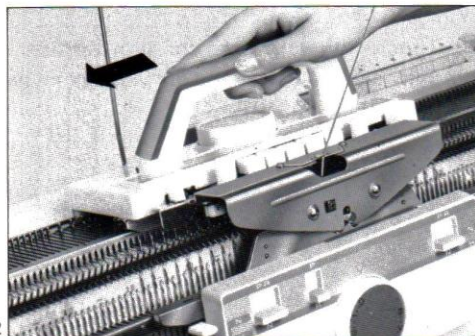

42

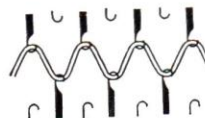

43

4. Hang on the cast-on comb
- Pull out the wire from the cast-on comb.
(Choose long or short one depending on the knitting width.)
Hold the cast-on comb with the face having the protrusions facing you and the teeth on top.
 - Put the cast-on comb between the knitter and the ribber from underneath and insert the teeth between the plain and purl needles in such a way that the top of the comb does not disturb or drop the yarn hanging on the needles. Pass the wire through the teeth with your right hand. While holding the comb with your left hand.
 - Hook the loose end of the yarn around the yarn clip to keep it out of the way and to tense the first stitch.

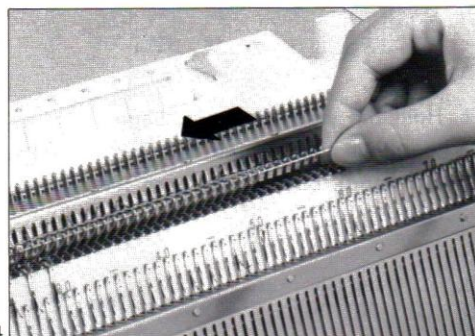

44



45

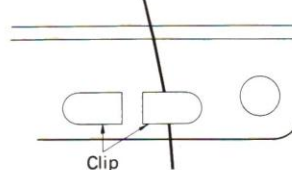

46

5. Hang on the weights
- Hang the weights as per Standard weights chart on page 11 on the cast-on comb to keep balance.

6. Perfect selvedge

- a. Set the carriages as shown in the Fig. 47.
- b. Move the connected carriage from left to right. (Only the plain needles knit.)

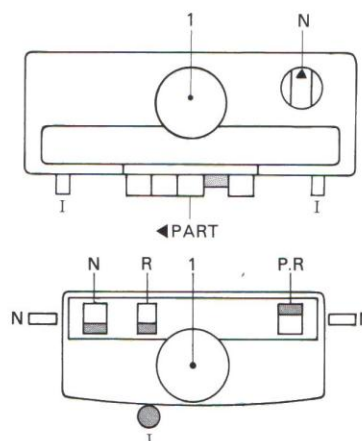

47

- c. Move the connected carriage from right to left. (The purl needles knit.)

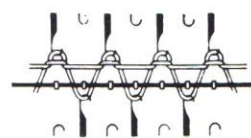

48

- d. Move the connected carriage from left to right. (The plain needles knit.)
The perfect selvedge has completed.

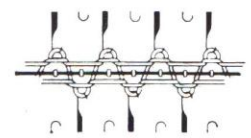

49

1 × 1 RIB KNITTING

- * After knitting the selvedge, set the carriages as shown in the Fig. 51. Then, continue the knitting.

50

Note: Don't take the carriage back until you hear the "click" or the carriage passes the last working needle.

YOU ARE NOW ABLE TO DO A FINISHED END CAST-ON. THIS METHOD IS VERY IMPORTANT, THEREFORE PLEASE PRACTICE THIS CAST-ON TWO OR THREE TIMES.

IF THE CARRIAGE SHOULD JAM WHILE KNITTING, PLEASE REFER TO PAGE 38 TO RELEASE IT.

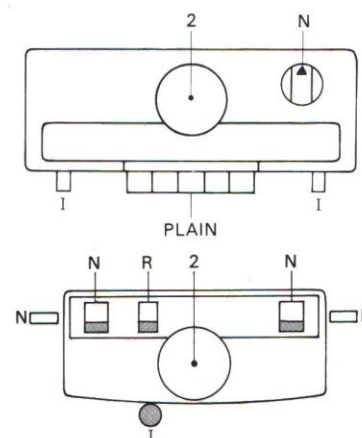

51

How to knit 2 × 2 rib

16

2 × 2 rib is 2 knit and 2 purl rib.
 In one row, 2 knit stitches alternate with 2 purl stitches and vertically form knit stitch over knit stitch and purl stitch over purl stitch.
 In the following example, medium thickness wool is used.



52

CASTING-ON FOR 2 × 2 RIB

1. Setting of carriage

Carriage (KH)
 Change knob : N
 Tension dial : O
 Holding cam lever : (L) I, (R) I
 Pattern selector button : PLAIN

Carriage (KR)
 Slide lever : II
 Tension dial : O
 Cam lever : (L) N, (R) N
 Tucking lever : R
 Holding cam lever : (L) N, (R) N

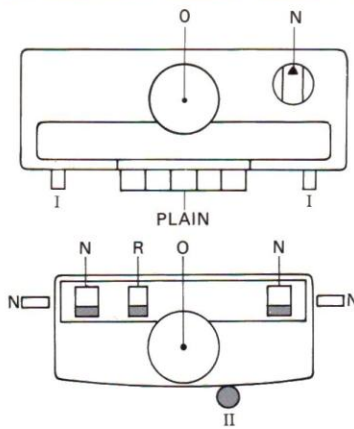

53

2. Needle arrangement

- Set the half pitch lever on "P", and racking indicator on No 5.
- By using 2/2 needle pusher, arrange the plain needles and purl needles in position B of each bed. (see Fig. 55.)

Note : Both end needles must be plain needles.

- Set the half pitch lever on "H".
- Set the racking indicator on No 4. (see Fig. 56.)



54

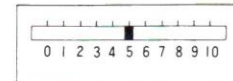

61



55

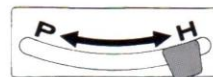

56

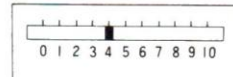

57

- e. Raise a purl needle in the left side to position B.
- f. Move the connected carriage a few times over all arranged needles to set them in a line.
Then, place the carriage at right end of the bed.

58



3. First row knitting

- a. Thread the yarn into the yarn feeder.
- b. Move the connected carriage from right to left. (The yarn will hang on plain and purl needles.)

59

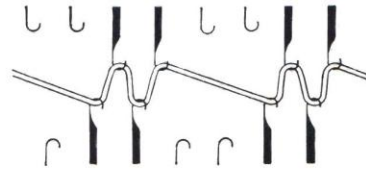

4. Hang on the cast-on comb

* This is in the same way as 1 x 1 rib.

- a. Hold the cast-on comb with the face having the protrusions facing you and the comb on top.
- b. Put the cast-on comb between the knitter and the ribber from underneath and insert the comb between the yarn hanging on the needles. And pass the wire.
- c. Hook the loose end of the yarn around the yarn clip.

60

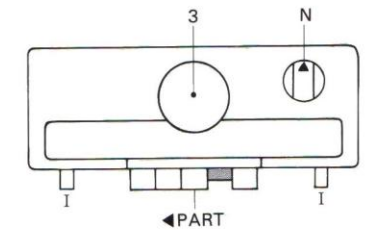

5. Hang on the weights

Hang the weights as per Standard weights chart on page 11 on the cast-on comb to keep balance.

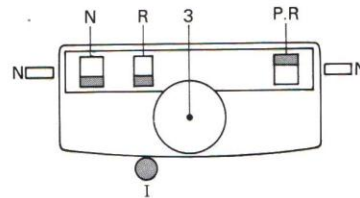

6. Perfect selvedge

- a. Set the carriages as shown in the Fig. 61.
- b. Move the connected carriage from left to right.
(Only the plain needles knit.)
- c. Move the connected carriage from right to left.
(The purl needles knit.)
- d. Move the connected carriage from left to right.
(The plain needles knit.)

61



62

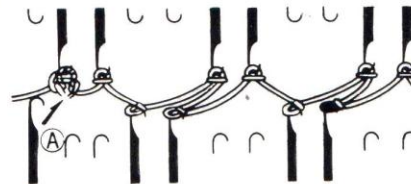

63

Return to position A

7. Needle arrangement to change from selvedge of the 2 × 2 rib knitting.
 - a. Set the half pitch lever to position "P".
 - b. Set the racking indicator on No 5.
 - c. By using the Double eyelet transfer needle, transfer the stitch of left end purl needle to the left end plain needle, and return the empty purl needle to position "A" of KR bed. (See Fig. 63.)

* How to transfer.....see on page 35.

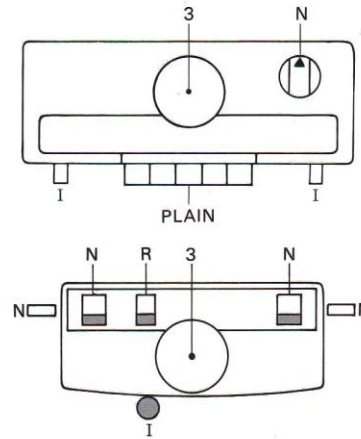

64

2 × 2 RIB KNITTING

- * After knitting the selvedge, set the carriages as shown in the Fig. 64
Then, continue the knitting.

DIFFERENT METHOD OF 2 × 2 RIB KNITTING

- a. Set the half pitch lever to "H", and arrange the needles as shown in the Fig. 66
- b. Set the racking indicator on No 4. Raise the left end purl needle to position B of KR bed.
- c. From the step "first row knitting" to "selvedge" are the same as original method. After selvedge, set the racking indicator on No 5.
- d. Transfer the left end purl stitch to the plain needle, and return the empty needle to A position of KR bed.
- e. The knitting is the same as original method.



65

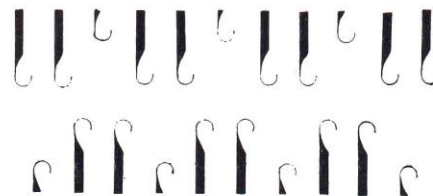

66

How to knit full needle rib

Knitting method of full needle rib is the same as for 1×1 rib. Difference is the needle arrangement only. In 1×1 rib, every other needles are used but in full needle rib, all needles are used. Fine wool (ex. 2ply) is suitable for this rib knitting.

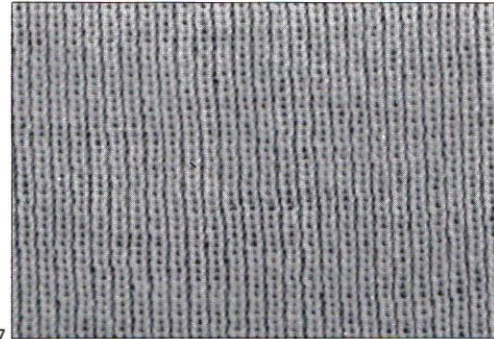

67

CASTING-ON FOR FULL NEEDLE RIB

1. Setting of carriage

- Carriage (KH)
 Change knob : N
 Tension dial : 0
 Holding cam lever : (L) I, (R) I
 Pattern selector button : PLAIN

- Carriage (KR)
 Slide lever : II
 Tension dial : 0
 Cam lever : (L) N, (R) N
 Tucking lever : R
 Holding cam lever : (L) N, (R) N

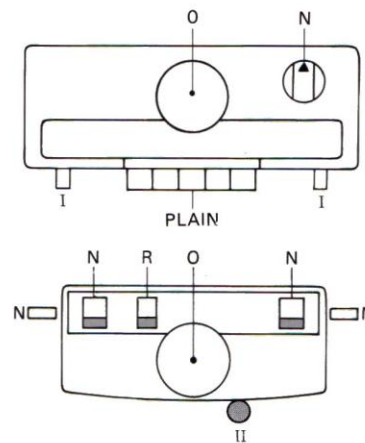

68

2. Needle arrangement

- a. Set the half pitch lever to "H".

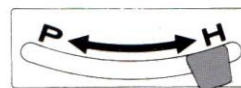

69

- b. Arrange the plain and purl needles in position B of each bed.

Note : Both end needles must be plain needles.

- c. Move the connected carriage a few times over all arranged needles to set them in a line. Then, place the carriage at right end of the bed.

70

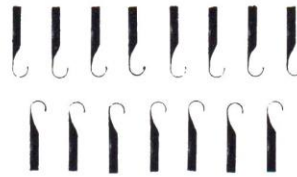

3. First row knitting

- a. Thread the yarn into the yarn feeder.
b. Move the connected carriage from right to left. (The yarn will hang on plain and purl needles.)

71

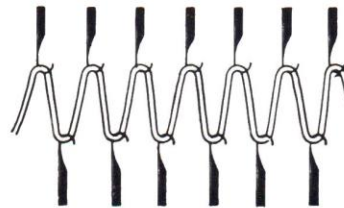

4. Hang on the cast-on comb

This is the same as 1×1 rib.

5. Hang on the weights

Hang the weights as per Standard weights chart on page 11 on the cast-on comb to keep balance.

6. Perfect selvedge

- a. Set the carriages as shown in the Fig. 72.
b. Move the connected carriage from left to right. (Only the plain needles knit.)
c. Move the connected carriage from right to left. (The purl needles knit the stitches.)
d. Move the connected carriage from left to right. (The plain needles knit.)

72

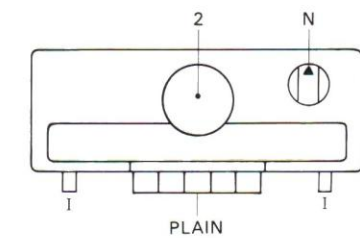
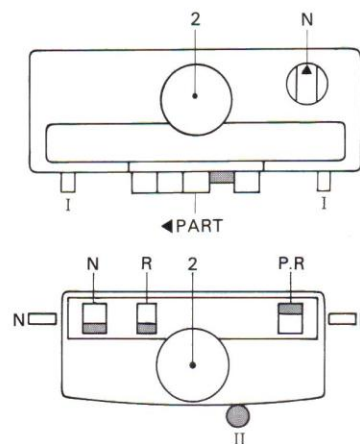

FULL NEEDLE RIB KNITTING

- * After knitting the selvedge, set the carriages as shown in the Fig. 73. Then, continue the knitting.

73

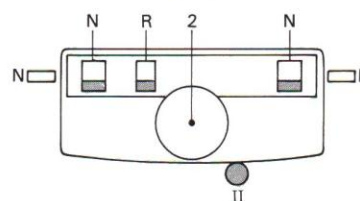

How to knit 5 × 5 rib

5 × 5 rib is called 5 knit 5 purl rib. In one row, there are 5 knit stitches alternating with 5 purl stitches, and vertically, from knit stitch over knit stitch and purl stitch over purl stitch.

The following example is knitted with medium thickness wool.



74

CASTING-ON FOR 5 × 5 RIB

1. Setting of carriage

Carriage (KH)

Change knob : N

Tension dial : O

Holding cam lever : (L) I, (R) I

Pattern selector button : PLAIN

Carriage (KR)

Slide lever : I

Tension dial : O

Cam lever : (L) N, (R) N

Tucking lever : R

Holding cam lever : (L) N, (R) N

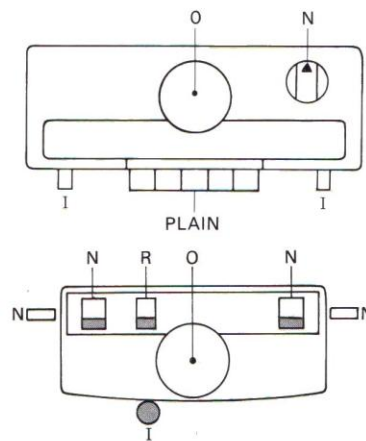

75

2. "Needle arrangement", "First row knitting", "Hang on the cast-on comb" and "Hang on the weights" are the same as full needle rib.

3. Perfect selvedge

- Set the carriages as shown in the Fig. 76.
- Move the connected carriage from right to left.
(Only the plain needles knit.)
- Move the connected carriage from left to right.
(The purl needles knit.)
- Move the connected carriage from right to left.
(The plain needles knit.)

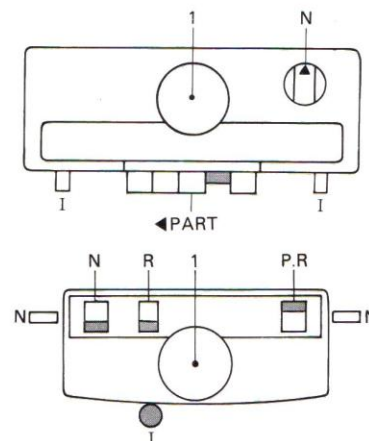

76

How to knit circular knitting

22

5 × 5 RIB KNITTING

1. After knitting the selvedge, by using the Double eyelet transfer needle, transfer the stitches to corresponded needles, and return the empty needles to position A of each bed. (see Fig. 77.)
2. Set the carriages as shown in the Fig. 78. Then, continue the knitting.

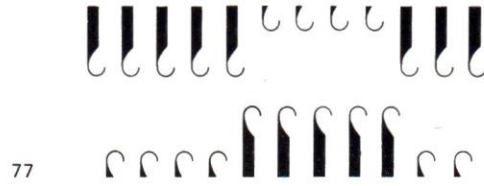

77

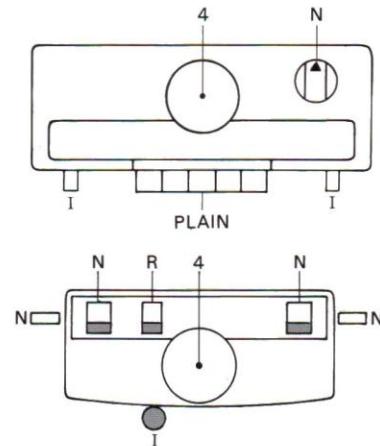

78

How to knit circular knitting.

Circular knitting is made up of only plain knit stitches, and is a jointless tube. Size of tube depends on the number of needles. Before you start to knit the garment, make the test piece to check the tension gauge. If there is slacken on the side, please adjust by the tension dial on the KR carriage. The example is knitted with medium thickness wool.



79

CASTING-ON FOR CIRCULAR KNITTING

1. Setting of carriage

Carriage (KH)

Change knob : N
 Tension dial : 6
 Holding cam lever : (L) I, (R) I
 Pattern selector button : PLAIN

Carriage (KR)

Slide lever : I
 Tension dial : 6
 Cam lever : (L) N, (R) N
 Tucking lever : R
 Holding cam lever : (L) N, (R) N

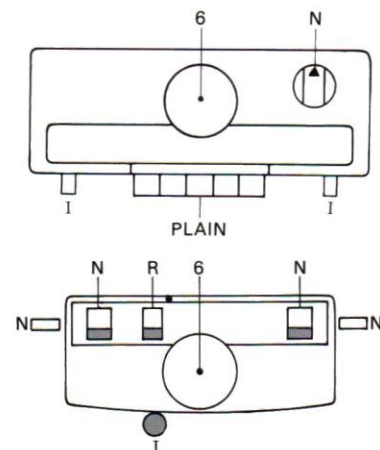

80

2. Needle arrangement

- Set the half pitch lever to "H".
- Arrange the plain and purl needles in position B of each bed. (see Fig. 82.)
Note : The number of needles between plain and purl needle must be same.
- Move the connected carriage a few times over all arranged needles to set them in a line. Then, place the carriage at right end of the bed.

81

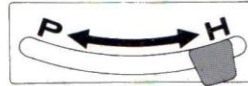

82

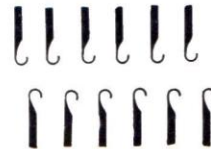

3. First row knitting

- Thread the **Cast-on thread** provided in the accessories of KH into the yarn feeder.
- Move the connected carriage from right to left. (The cast-on thread will hang on plain and purl needles.)

4. Hang on the cast-on comb

*This is the same way as 1×1 rib.

5. Hang on the weights

Hang the weights as per Standard weights chart on page 11 on the cast-on comb to keep balance.

- Remove the cast-on thread from the yarn feeder, and rethread the knitting yarn into the feeder.

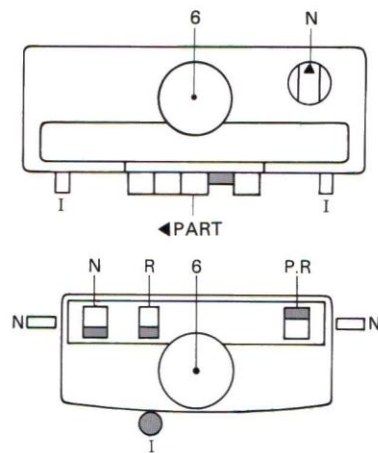

83

CIRCULAR RIB KNITTING

- * Set the carriages as shown in the Fig. 83 .
Then, continue the knitting.

How to knit "U" style knitting

24

This garment is made of all plain knitting stitches. The knitter side and the ribber side are connected at only one side. This knitting is used for work of more than 200 stitches width. In the following, the garment is knitted with closed right side and open left side.

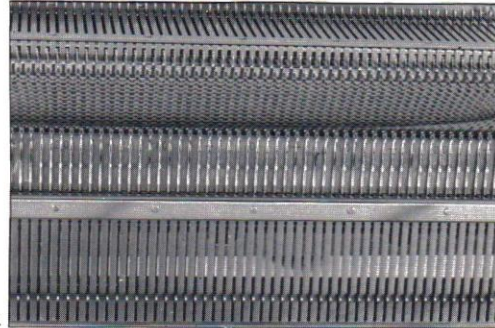

84

CASTING-ON FOR "U" STYLE KNITTING

*This is the same as for circular knitting.
The connected carriages is on the left side of the bed after casting-on.

"U" STYLE KNITTING

1. Set the carriages as shown in the Fig. 85, and knit 2 rows.

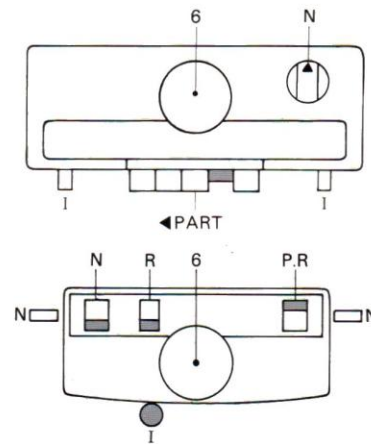

85

2. Then, reset the carriages as shown in the Fig. 86, and knit 2 rows.

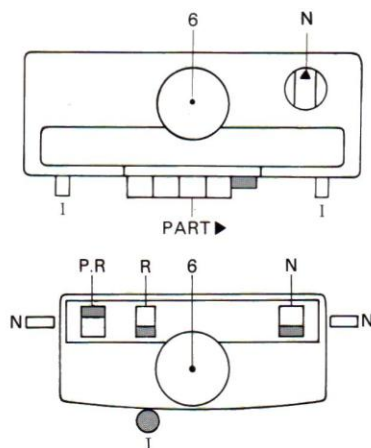

86

3. Repeat step (1) to (2), then you can make "U" style knitting.

How to knit English rib

How to knit fisherman's rib

ENGLISH RIB

English rib is a variety of 1×1 rib, and knitter side is plain stitch but ribber side is tuck stitch.

The example is knitted with medium thickness wool.

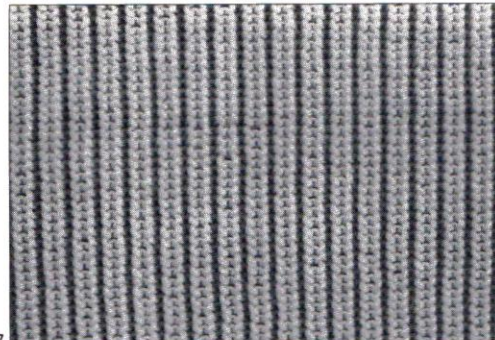

87

CASTING-ON FOR ENGLISH RIB

* This is the same as for 1×1 rib.

ENGLISH RIB KNITTING

* Set the carriages as shown in the Fig. 88, and continue the knitting.

Note: Hang the Wire-loop type weight hanger and small weight on the edge of the knitting work to avoid stitch dropping.

How to use see on page 11.

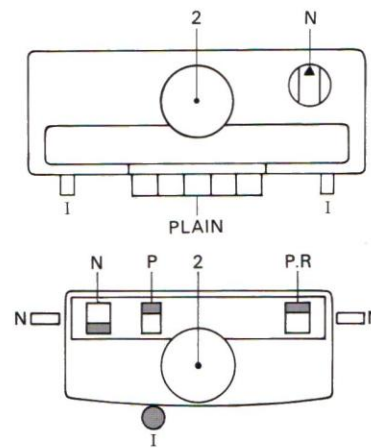

88

FISHERMAN'S RIB

Fisherman's rib is made of tucking stitches on both sides of garment.

The example is knitted with medium thickness wool.

CASTING-ON FOR FISHERMAN'S RIB

* This is the same as for 1×1 rib.

FISHERMAN'S RIB KNITTING

* Set the carriages as shown in the Fig. 90, and continue the knitting.

Note: Put the Needle presser brushes to the KH carriage.

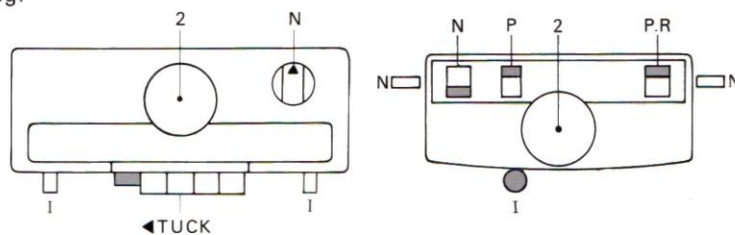

90

89



How to knit tucking pattern

26

Tucking pattern is a variation of 1×1 rib or full needle rib. In the following description, tucking pattern of full needle rib is made. The example is knitted with fine wool (Ex. 2ply).



CASTING-ON FOR TUCKING PATTERN

*This is the same as for full needle rib.

TUCKING PATTERN KNITTING

1. Set the carriages as shown in the Fig92.
2. Set the slide dial to position 1.
3. Push the needle selector buttons No. 1, 3, 5 & 7.
4. Set the reverse lever to position A, and turn the set lever to select the needles.
5. Move the carriage from right to left.
6. Turn the set lever to select the same needles as the step 4.
7. Move the carriage from left to right.
8. Shift the reverse lever position from A to B, and turn the set lever.
9. Move the carriage from right to left.
10. Turn the set lever to select the same needles as the step 8.
11. Move the carriage from right to left.
12. Repeat the steps from 4 to 11 to proceed the knitting.

Note : If the end needles of KH bed is not brought by the carriage, bring to position D by hand.

Put the Needle presser brushes to the KH carriage.

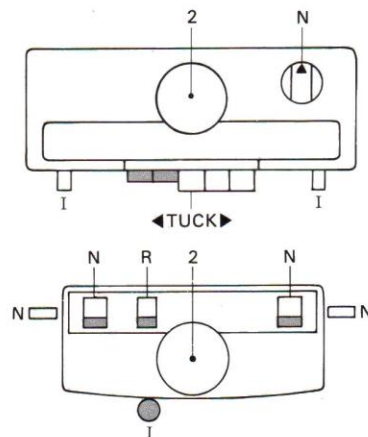

How to knit racking pattern of English rib

The example is knitted with medium thickness wool.

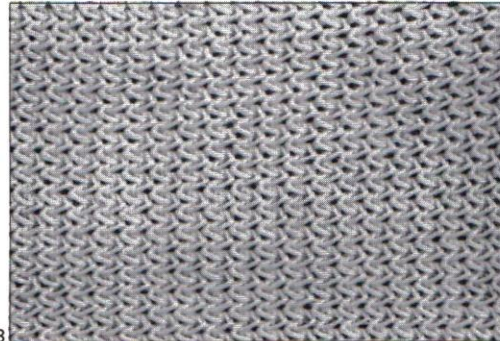

CASTING-ON FOR RACKING PATTERN OF ENGLISH RIB

1. Set the racking indicator on No. 5, and cursors on the indicator to No. 4 and No. 5.

2. The other steps are the same as for 1×1 rib.

3. After knitting the selvedge, set the half pitch lever on "H".

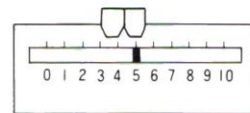

RACKING PATTERN KNITTING

1. Set the carriage as shown in the Fig. 95.

2. Move the connected carriage from right to left. (The plain needles knit and purl needles have two loops each on their hooks.)

3. Set the racking indicator on No. 4.

4. Knit two rows.

5. Set the racking indicator on No. 5.

6. Move the connected carriage from left to right. (One row)

7. repeat step (2) to (6).

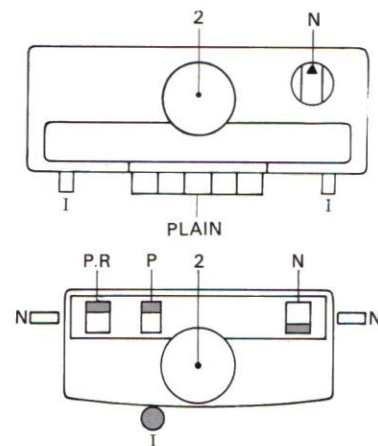

How to knit racking pattern (I)

28

The example is knitted with medium thickness wool.

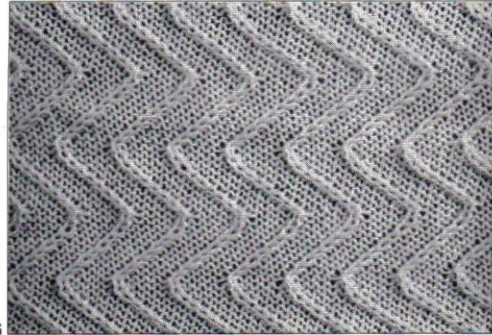

96

CASTING-ON FOR RACKING PATTERN (I)

- * Set the racking indicator on No. 0.
- The other steps are the same as for full needle rib.

RACKING PATTERN (I) KNITTING

1. After knitting the selvedge, using the Double eyelet transfer needle, transfer the part (A) stitches to opposite plain needles, and return the empty needles to position A of KR bed.
- How to use.....see on page 35.
2. Set the carriages as shown in the Fig. 98.
3. Move the connected carriage from right to left. (The plain and purl needles knit.)
4. Set the racking indicator on No. 1.
5. Move the connected carriage from left to right.
6. Set the racking indicator on No. 2.
7. Continue the same manner until the racking indicator indicates No. 10.
8. Move the connected carriage from right to left.
9. Set the racking indicator on No. 9.
10. Continue the same manner until the racking indicator indicates No. 0.
11. The pattern knitted from step (3) to (10) is one cycle.

Note : Don't turn the racking grip handle when the needles are raised over the gate pegs.

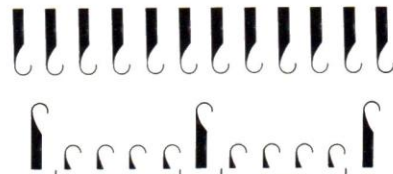

97

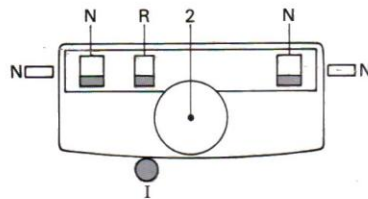
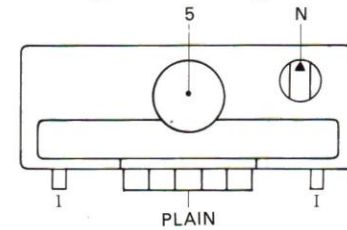

98

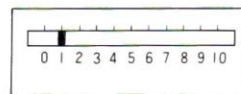

99

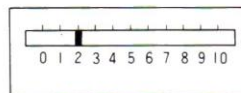

100

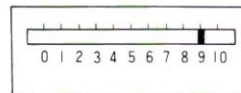

101

How to knit racking pattern (II)

The example is knitted with fine (ex. 2ply) wool.

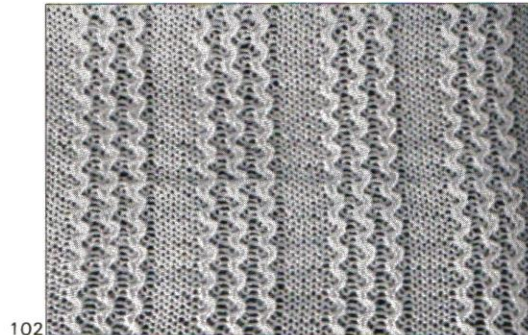

CASTING-ON FOR RACKING PATTERN (II)

*This is the same as for full needle rib, and set the cursors to No. 5. and No. 7.

103

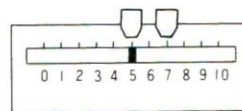

RACKING PATTERN (II) KNITTING

1. After knitting the selvedge, using the Double eyelet transfer needle, transfer the part (A) stitches to opposite plain needles, and return the empty needles to position A of KR bed.

104

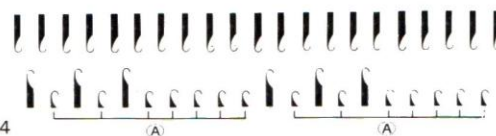

2. Set the carriages as shown in the Fig. 105.
3. Move the connected carriage from right to left.
4. Move the connected carriage from left to right.
5. Set the racking indicator on No. 7.
6. Move the connected carriage from right to left.
7. Move the connected carriage from left to right.
8. Set the racking indicator on No. 5.
9. Repeat the step (3) to (8).

105

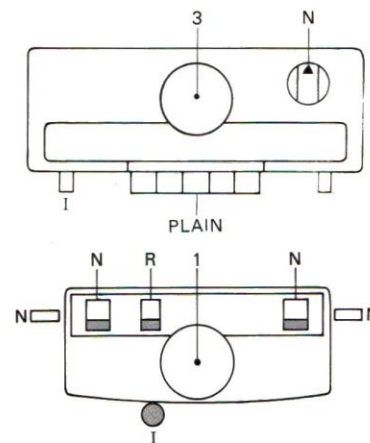

Increasing the stitches

30

1. Increasing one stitch on one side of knitting width.

SIMPLE METHOD

- a. Place the carriage on the side which you want to increase.
- b. Raise the end needle to the working position B. (see Fig. 106.)
- c. The empty needle will pick up the yarn as it knits the next row.

106

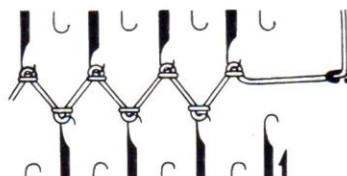

FULL FASHIONED METHOD

- a. Use the transfer tool, move the first stitch (1) onto the adjacent empty needle (2).
Now second needle from the end becomes empty.
- b. Pick up either neighbouring lower loop (3), and hook on the empty needle (1).

107

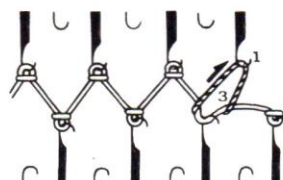

2. Increasing more than two stitches on either side of the garment.

- a. Place the carriage opposite to the side you want to increase.
- b. bring into action on the side opposite to the carriage as many needles as the number of stitches to be increased.
- c. Move the carriage.
- d. The yarn will hang on the increased needles on both sides.
- e. Hang the weight hanger for side tension and small weight on the yarn which is shaping zigzag line.
- f. Continue the knitting.

Decreasing the stitches

1. Decreasing one stitch on either end.

SIMPLE METHOD

* By using the single transfer tool, transfer the end stitch to the second needle, and take the empty needle out of action.

108

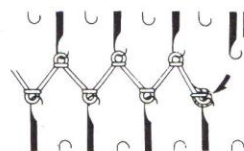

SECOND METHOD

- a. Use two-needles transfer tool. Transfer the end stitch to the second needle and the second needle to the third needle.
- b. Take the empty needle out of action.

109

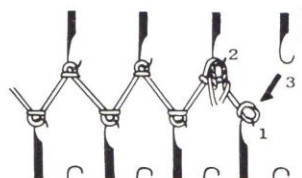

2. Decreasing more than two stitches.

- a. Place the carriage opposite to the side you want to decrease.
- b. Use the tapestry needle. Transfer the stitches which you want to decrease to the stem of the tapestry needle and pass through loops of stitches to be decreased.
- c. Take the empty needles out of action.

110

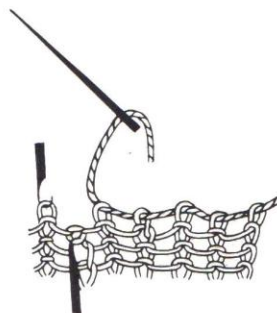

Partial knitting of ribbing

32

Partial knitting is used for shaping of garment, making darts, shaping of a heel, vertical and horizontal buttonholes, neck opening, pockets etc. There are two cases, one is decreasing of knitting part, another one is increasing of knitting part.

PARTIAL KNITTING OF 1 × 1 RIB

* The example is partial knitting of 1 × 1 rib, however, 2 × 2 rib, full needle rib, 5 × 5 rib, English rib, Fisherman's rib and Tucking pattern rib are the same manner as 1 × 1 rib.

1. Decreasing knitting part.

- a. Set the both carriages as shown in the Fig. 112
- b. Bring the nonknitting needles of KH and KR beds to position E.
- c. Move the connected carriage from right to left. (The needles on position B knit, and the yarn is across on the needles on position E.)
- d. To avoid a hole in the knitting, hook the yarn laying across on the needles on position E to the next needle of KR to the knitting. (see Fig. 113.)
- e. Move the connected carriage from left to right.
- f. Repeat step (b) to (e) according to the shape of the garment.

* After partial knitting, if you want to knit all needles, simply set H.C.L.s. of both carriages to normal position. And move the carriage.

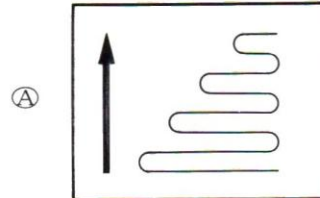

111

Decreasing knitting part

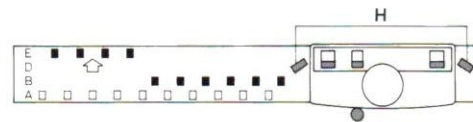
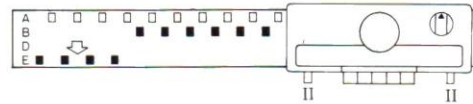

112

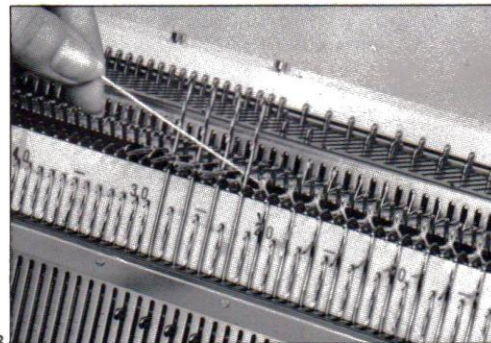

113

2. Increasing knitting part

- a. Set the both carriages as shown in the Fig. 114.

* For 1×1 rib, 2×2 rib and full needle rib, bring back the required needles you want to knit to position D of each bed. (see Fig. 114.)

* For English rib, Fisherman's rib and Tucking pattern rib, bring back the required needles you want to knit to position D, and using the transfer tool, place the stitch behind the latch into the hook. Then, return these needles to position B. (see Fig. 115.)

- b. Move the connected carriage from right to left.

(The needles on position B and D knit, and the yarn is across on the needles on position E.)

- c. To avoid a hole in the knitting, hook the yarn laying across on the needles on position E to the next needle to the knitting.
- d. Move the connected carriage from left to right.
- e. Repeat step (a) to (d) according to the shape of garment.

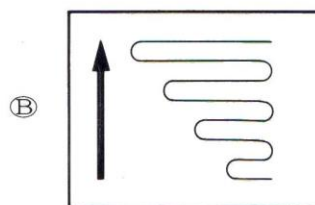

Increasing knitting part

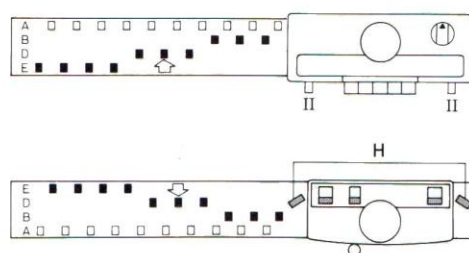

114

Return the stitch into the hook

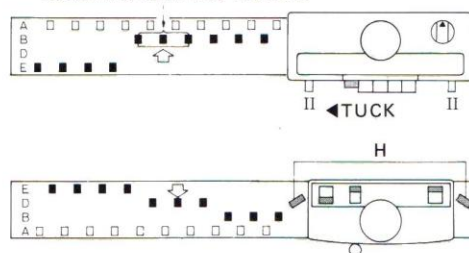

115

PARTIAL KNITTING OF RACKING PATTERN

* In the racking pattern, it is impossible to bring both needles to position E, so, please knit partial knitting of racking pattern according to the following method.

The example is racking pattern of English rib.

1. Decreasing knitting part.

- a. Set the carriages as shown in the Fig. 116
- b. Bring the nonknitting needles of KR bed to position E.
- c. Bring the knitting needles of KH bed to position E.

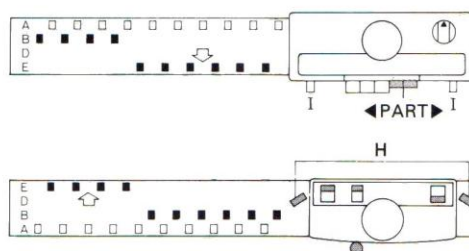

116

- d. Move the connected carriage from right to left. (The plain needles on Position E and purl needles on position B knit, and the yarn is across on the purl needles on position E.)
- e. To avoid a hole in the knitting, hook the yarn laying across on the purl needles on position E to the next needle to the knitting,
- f. Set the racking indicator on next number.
- g. Bring the knitting needles of KH bed to position E.
- h. Move the connected carriage from left to right.
- i. Repeat step (b) to (e).
- j. Set the racking indicator on next number.
- k. Bring the knitting needles of KH bed to position E.
- l. Move the connected carriage from left to right.
- m. Repeat step (b) to (l) according to the shape of garment.

2. Increasing knitting part.

- a. Set the carriages as shown in the Fig. 117.
- b. Bring back the required needles you want to knit to position D, and using the transfer tool, place the stitch behind the latch into the hook. Then, return these needles to position B.
- c. Bring the knitting needles of KH bed to position E.
- d. Move the connected carriage from right to left. (The plain needles on position E and purl needles on position B knit, and the yarn is across on the purl needles on position E.)
- e. To avoid a hole in the knitting, hook the yarn laying across on the purl needles on position E to the next needle to the knitting.
- f. Set the racking indicator on next number.

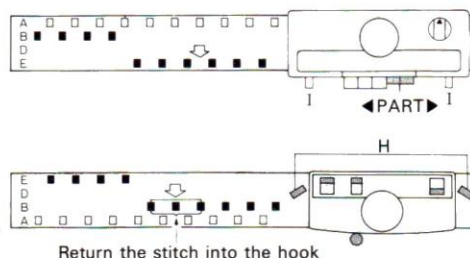

117

- g. Bring the knitting needles of KH bed to position E.
- h. Move the connected carriage from left to right.
- i. Repeat step (b) to (e).
- j. Set the racking indicator on next number.
- k. Bring the knitting needles of KH bed to position E.
- l. Move the connected carriage from left to right.
- m. Repeat step (b) to (l) according to the shape of garment.

How to transfer the stitch from the purl needle to plain needle or from plain needle to purl needle.

HOW TO TRANSFER THE STITCHES

1. How to transfer from purl needle to plain needle.

- a. Raise the plain needle from position A to B, and open the latch.
- b. By using the transfer tool, transfer the stitch on the purl needle to the empty plain needle.

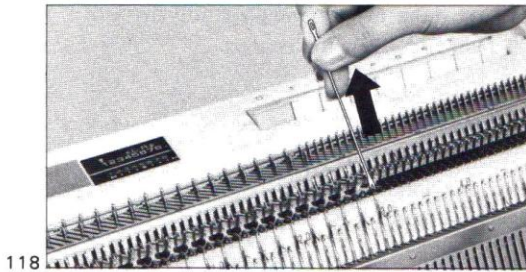

118

2. How to transfer from plain needle to purl needle.

- a. By using the transfer tool, transfer the stitch on every other plain needle to the corresponding purl needle.

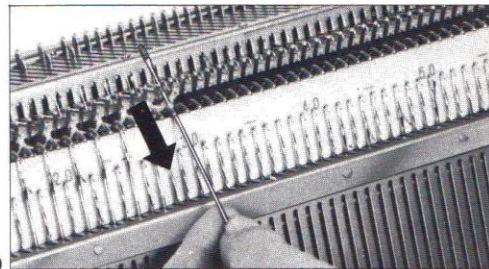

119

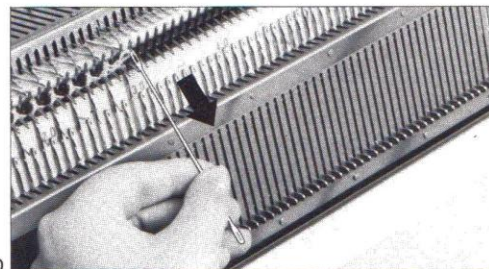

120

BINDING OFF AND FISHING EDGE OF RIB KNITTING

* This method is used for binding up the stitches of the last row by using the yarn of rib knitting. Binding up is the same as selvedge.

When you finish rib knitting, knit one or three rows of circular knitting, then bind the last row by using the tapestry needle as shown in the figures.

The length of the yarn for binding is 3 times the width of knitting.

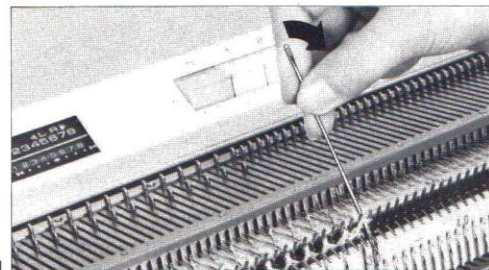

121

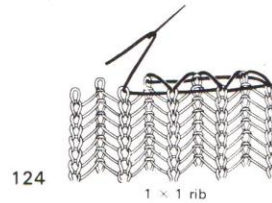
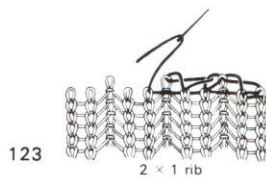
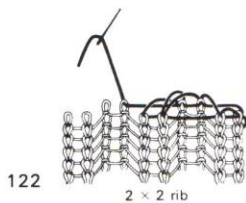

How to pick up dropped stitch

Unravelling the rows

36

* First, take off the weights and prevent dropping of multiple rows.

1. In case one stitch is dropped.
 - a. With the single transfer tool or work hook, pick up the stitch and the unknitted yarn and put them on the empty needle.
2. In case multiple rows are dropped.
 - a. Open the gate by pushing down both bracket levers, and catch the lowest loop of the dropped stitches with latch tool.
 - b. With the latch tool, make the stitches, and hang the final stitch on the empty needle.

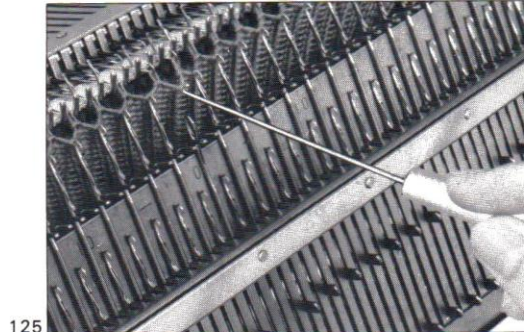

125

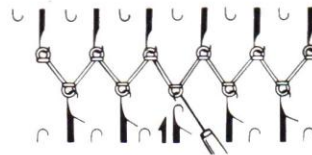

126



127

Unravelling the rows

* If you have knitted more than necessary, do not remove the work from the knitter and ribber. Simply unravel one or several rows by doing the following.

Pull the yarn slightly, drawing it out of the stitches.

The stitches of the previous row will slip into the hook of the needles automatically as the yarn is raised in an upward movement towards the needle bed.

128



If the carriage should jam..... How to use the knitter as a single bed with the ribber attached

37

IF THE CARRIAGE SHOULD JAM

1. Disconnect the carriage See on the page 10.
Lift the front of the KH Carriage and move to the side where the row commenced.
2. Remove the front foot from the front rail of KR needle bed. And place the KR carriage at the same side of KH carriage. (Fig. 130)
3. Connect both carriages.
4. Work the corrections if required.
5. Continue the knitting.

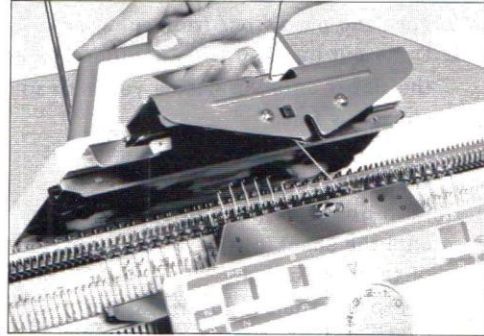

129

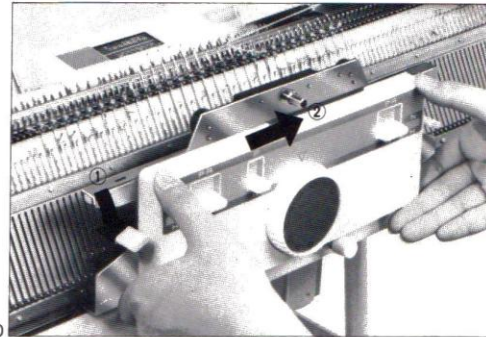

130

HOW TO USE THE KNITTER AS A SINGLE BED

- a. Disconnect the carriage.
- b. Push down both bracket levers of the ribber and the ribber will come down one step.
- c. Take off the connecting arm from the KH carriage, and convert it to the sinker plate assembly of knitting machine.
- d. The knitter can be used as a single bed.

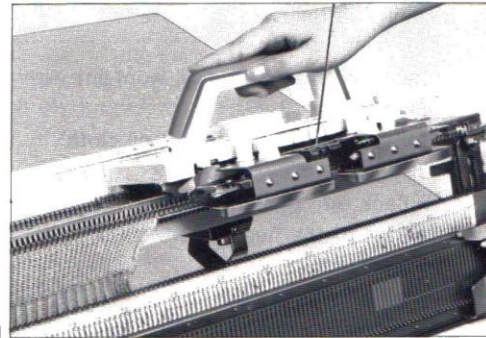

131

How to replace the purl needle

Maintenance

38

How to replace the purl needle.

- a. Push the plastic bar from either side.
- b. Draw out by hand from another side of the ribber until the needle you wish to change is free.
- c. Bring forward the needle as far as it will go.
- d. Push down the hook of the needles until the shank of the needle rises free of the needle bed.
- e. Grasp the shank and draw it out backwards.
- f. Replace new needle with latch opened.
- g. Push in the bar, making sure that the flat face is down.

132

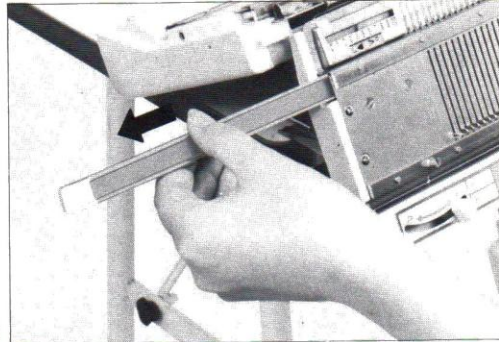

133

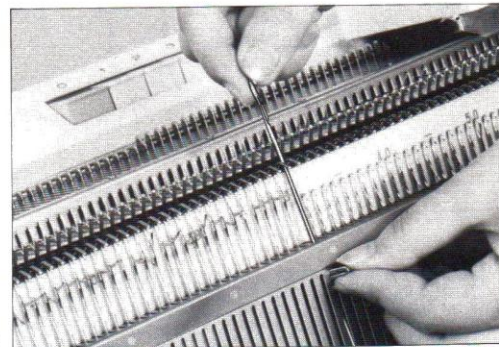

* Each time you finish work, service your machine as follows :

- a. Clean the machine of all wool lint with hand brush.
- b. Polish each part with soft oil cloth.
- c. Oiling the following parts.
 - * Back side of the carriage.
 - * Rails of the needle bed.
 - * Needle butts.
- d. Wipe off stained oil.
- e. Keep your machine in a dry place.

134

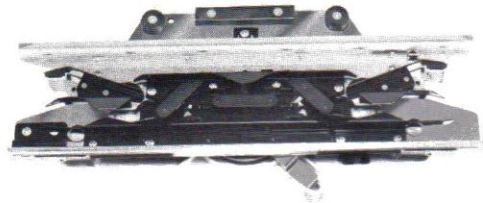

135

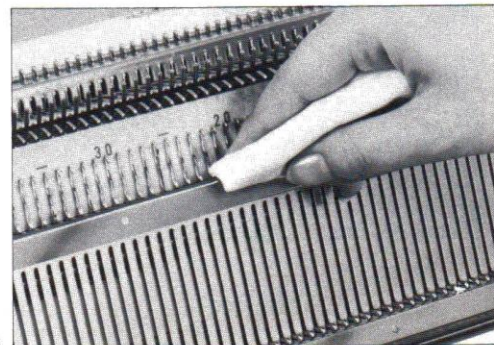

I N D E X

Name of parts.....	1
Accessories.....	2
Setting up your ribber to the knitter.....	3
Joining the carriage.....	5
Important points to remember before you start knitting.....	8
Tension dial, Slide lever.....	8
Needle position, Half pitch lever, Racking grip handle.....	9
Bracket lever.....	10
Disconnecting the carriage.....	10
How to use the accessories.....	11
How to knit 1 × 1 Rib.....	12
How to knit 2 × 2 Rib.....	16
How to knit Full needle Rib.....	19
How to knit 5 × 5 Rib.....	21
How to knit Circular knitting.....	22
How to knit "U" style knitting.....	24
How to knit English Rib.....	25
How to knit Fisherman's Rib.....	25
How to knit Tucking pattern.....	26
How to knit Racking pattern of English Rib.....	27
How to knit Racking pattern.....	28
Increasing the stitches.....	30
Decreasing the stitches.....	31
Partial knitting of ribbing.....	32
How to transfer the stitches.....	35
Binding off and finishing edge.....	35
How to pick up dropped stitch and unravelling the rows.....	36
If the carriage should jam.....	37
Using the knitter as a single bed with ribber attached.....	37
How to replace the purl needle.....	38
Maintenance.....	38

Special instructions for attaching the ribber to the KH-588 knitting machine

40

1. Remove the extension rail holders on either side of the needle bed of KH-588. Then, attach the ribber to the knitting machine (see on pages 3 and 4). The thumb screws are not used for fixing the ribber.

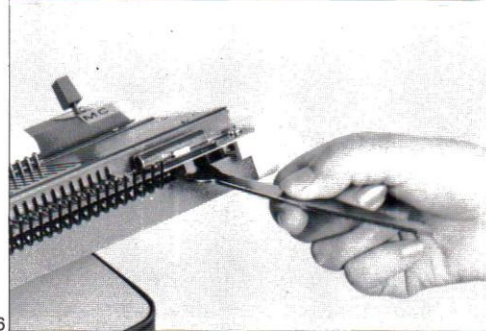

136

2. Take the 2 pcs. each of the extension rail holders for KR and set screws out of the accessories box. And put them onto the bracket stopper on either side of the ribber and fasten them by set screws temporary. Insert the extension rail into the holder.

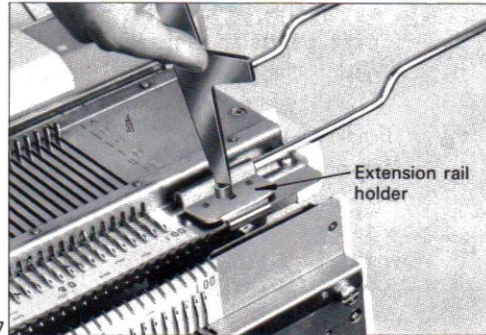

137

3. You are requested to adjust the distance from the knitter to the ribber before starting the knitting. Turning the adjusting screw to the left by the spanner, adjust the distance. By turning the adjusting screw to the left one revolution (360°), the ribber will go inside (to close) by about 1 mm. The correct distance is about 0 ~ 1.2 mm. For your reference, the thickness of the claw type weight hanger is 0.6 mm. After adjusting, tighten both set screws.

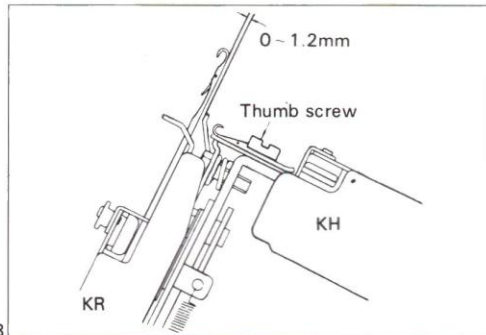

138

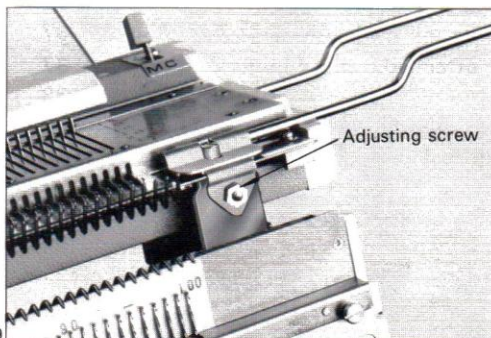

139

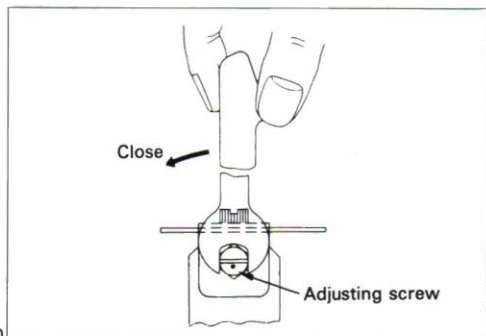

140

