

Simply Fashionable

brother

7mm PITCH KNITTER



2





3

4





5



6

ABBREVIATIONS

approx	approximate	oz	ounces
beg	begin(ing)	patt	pattern
carr	carriage	PL	part lever(s)
CC	contrasting color	RC	row counter
cm	centimeter(s)	RC000	set row counter to 000
dec	decrease(ing)	rem	remain(ing)
EON	every other needle	RS	right side
EOR	every other row	st(s)	stitch(es)
folll	following	St st	stocking stitch
g	gram(s)	TD	tension dial
HCL	holding cam lever(s)	WP	working or B position
HP	holding or E position	WS	wrong side
inc	increase(ing)	WY	waste yarn
"	inch(es)	waste knit	change to waste yarn, knit a few rows and release from machine
MC	main color	work even	work in the indicated pattern without increasing or decreasing
MT	main tension	-----	broken line indicates folding line
N(s)	needle(s)		
NWP	non working or A position		

FINISHED CAST ON EDGE METHOD 1x1 RIB

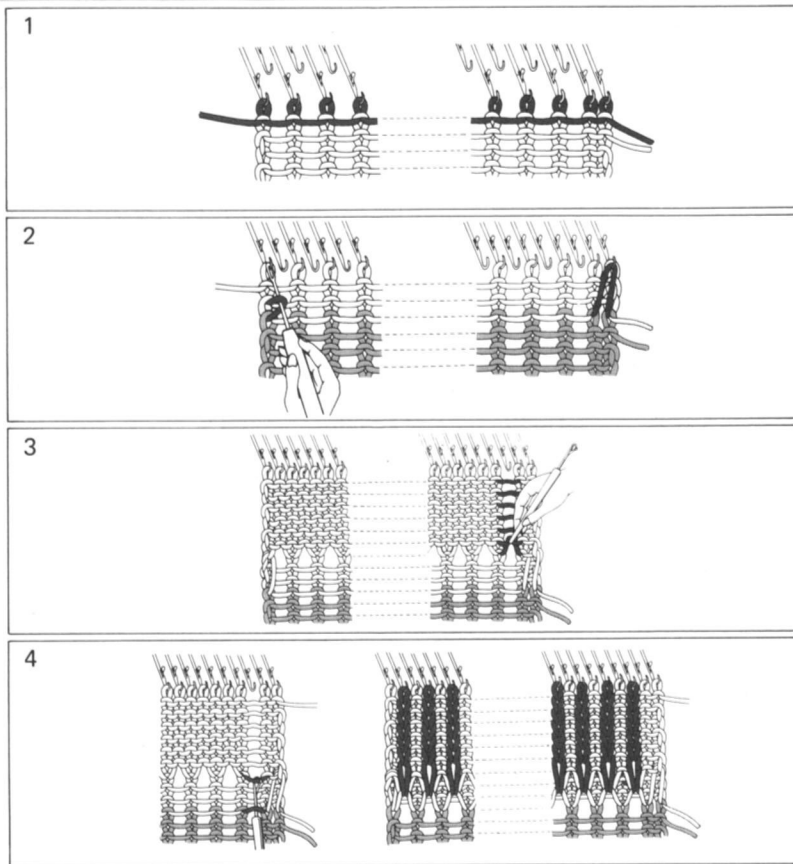

Push EON to WP (2 Ns at right are in WP). Set TD to 4 numbers lower than MT. Knit a few rows with WY, carr ending at right. Knit 3 rows with MC.

Pick up loop on each end of 1st row and hang them onto end Ns. Push all Ns to WP.

Set to TD to 2 numbers lower than MT. Knit required rows. Drop 3rd st from right end and unravel sts.

Insert latch tool under loop of 1st row and catch 4th parallel thread (skip 2 rows), then pull latch tool towards you to make a plain st. Repeat this until you reach top, hook st onto N. Repeat procedure on EON.

GAUGE/TENSION

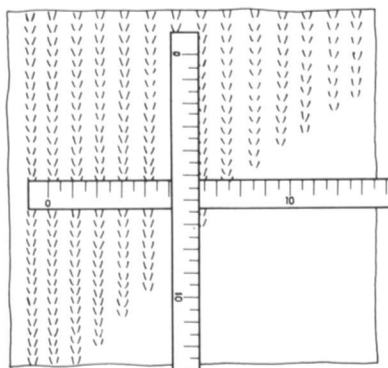

GAUGE is the number of sts and rows per 4"/10 cm. It depends on TD and the yarn you are using. In order for your garment to fit properly, it is important that your gauge match the one in the instructions. Measure the number of sts and rows in 4" and compare with the given gauge. If you have more sts and rows than specified, set TD to larger number; If you have fewer, set TD to smaller number.



COVER

1. WOMAN'S DOLMAN SLEEVE SWEATER

SIZES

To fit 32 (34, 36, 38, 40)"/81 (86, 91, 96, 101) cm bust.

Directions are for smaller sizes with larger sizes in parentheses. If there is only one set of figures it applies to all sizes.

KNITTED MEASUREMENTS

* Finished bust measurement at underarm 35 (38, 40, 42, 44)"/90 (96, 100, 106, 110) cm.

* Length 25½"/65 cm

MATERIALS

9 (10, 11, 12, 13) [1¼ oz/50g] balls of PINGOUIN "Ondine" in #6 Blue (MC).

3 [1¼ oz/50g] balls of PINGOUIN "Fraïandise" in #8 Blue (CC1)

2 [1¼ oz/50g] balls of PINGOUIN "Rebane" in #32 Blue (CC2)

GAUGE/TENSION

16 sts and 26 rows to 4"/10 cm in stripe patt with TD7.

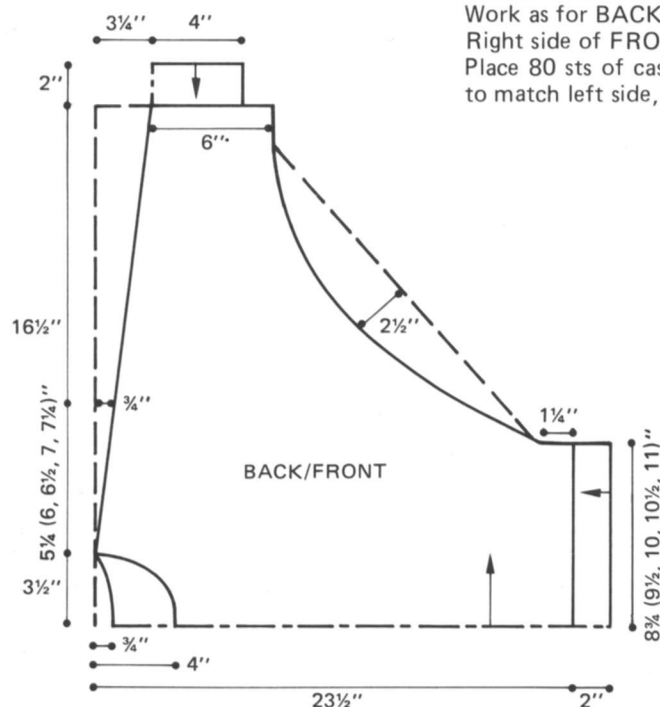

(↑) arrow indicates knitting direction.

NOTE

* Stripe patt (22 row repeats) — 8 rows with MC, every 2 rows with CC1, CC2 and CC1, 8 rows with MC.

* Purl side is right side of fabric.

* Sideway knitting — Start from center of BODICE.

* Finished cast on 1x1 RIB

Refer to METHOD on page 7.

BACK

Right side of BACK

Using WY, cast on 93 sts. Knit a few rows, ending with carr on right. Change to TD7. RC000. Start with MC. Work even in stripe to RC20.

Neck shaping

Knit 1 row. At beg of next and EOR, inc 1 st once, 2 sts once to RC24.

Shoulder and sleeve shaping

Knit 11 rows. Dec 1 st at left edge every 10th row 10 (9, 7, 5, 4) times, every 12th row 3 (4, 6, 8, 9) times. Work even to RC168 (172, 176, 180, 182). AT THE SAME TIME ... At RC60 (62, 66, 70, 72) at beg of next and EOR at right edge, Dec 5 sts once, 3 sts once, 2 sts 6 times, 1 st 3 times, 2 sts 3 times. Knit 2 rows. Dec 1 st at beg of next and EOR 15 times, every 4th row 12 times. Work even to RC168 (172, 176, 180, 182). Waste knit 24 sts.

Left side of BACK

Place 93 sts of cast on row onto Ns. Knit to match right side, reversing shaping.

FRONT

Left side of FRONT

Using WY, cast on 80 sts. Knit a few rows, ending with carr on right. Change to TD7. RC000.

Neck shaping

Using MC, knit 3 rows. At beg of next and every 4th row, inc 1 st twice. Knit 2 rows. At beg of next and EOR, inc 1 st 3 times, 2 sts twice, 7 sts once in stripe. Work even to RC24.

Shoulder and sleeve shaping

Work as for BACK.

Right side of FRONT

Place 80 sts of cast on row onto Ns. Knit to match left side, reversing shaping.

BOTTOM WELT (2 pieces)

Using WY, cast on EON between 37 at each side at center 0. (37-0-37). Knit a few rows, ending with carr on left. Using MC, finished cast on 74 sts as 1x1 RIB. Change to TD5. RC000. Knit 14 rows. Make 1x1 RIB. Waste knit.

CUFFS (2 pieces)

Knit as for BOTTOM WELT, using 30 sts.

FINISHING

With WS up, block and steam pieces. Attach BOTTOM WELT to BODICE. Join shoulder and sleeve seams. Attach CUFF to BODICE. Join side and underarm seams. Using a crochet hook, work slip st with MC at neckline. Work single crochet with MC and backward crochet with CC2. Give a final steam.



page 2

2. WOMAN'S SLASH NECK SWEATER

SIZES

To fit 34 (36, 38, 40, 42)"/86 (91, 96, 101, 106) cm bust.

Directions are for smaller sizes with larger sizes in parentheses. If there is only one set of figures it applies to all sizes.

KNITTED MEASUREMENTS

* Finished bust measurement at underarm 38 (40, 42, 44, 46)"/96 (101, 106, 111, 116) cm

* Length 21¼ (22, 22¾, 23½, 24½)"/54 (56, 58, 60, 62) cm

* Sleeve width at upper arm 18¼ (19, 19½, 20½, 21¼)"/46 (48, 50, 52, 54) cm

MATERIALS

9 (10, 10, 11, 12) [1¼ oz/50g] balls of JAEGER "champagne" in #943 Viridian (MC)

GAUGE/TENSION

19 sts and 29 rows to 4"/10 cm in St st with TD5.

NOTE

* Finished cast on for 1x1 RIB
Refer to METHOD on page 7.

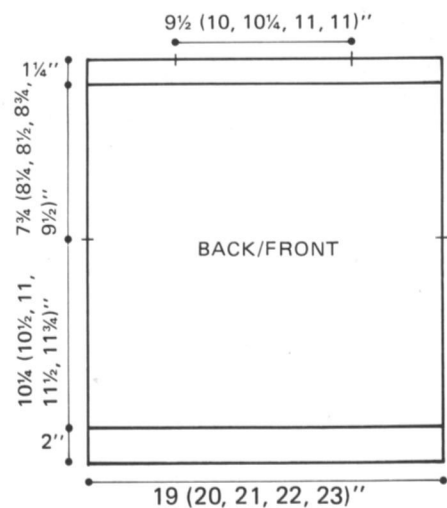

page 3

3. WOMAN'S SUMMER SWEATER

SIZES

To fit 32 (34, 36, 38, 40)"/81 (86, 91, 96, 101) cm bust.

Directions are for smaller sizes with larger sizes in parentheses. If there is only one set of figures it applies to all sizes.

KNITTED MEASUREMENTS

* Finished bust measurement at underarm 36 (38, 40, 42, 44)"/91 (96, 101, 106, 111) cm

* Length 21 1/2 (22, 22 1/2, 22 3/4, 23 1/4)"/55 (56, 57, 58, 59) cm

* Sleeve width at upper arm 18 (19, 19 1/2, 20 1/2, 21)"/46 (48, 50, 52, 54) cm

MATERIALS

9 (10, 10, 11, 12) [1 1/4 oz/50g] balls of PATONS "SUPERSOFT D.K." in #2292 Blue (MC)

GAUGE/TENSION

19 sts and 28 rows to 4"/10 cm in St st with TD7.

NOTE

* Lace patt is repeated 3 times.

* Collar is in St st then left to roll naturally.

BACK

Using WY, cast on EON between 46 (48, 50, 53, 55) on each side of center 0. Knit a few rows, ending with carr on left. Using MC, finished cast on 92 (96, 100, 106, 110) sts. Knit 16 rows, TD4. Make 1x1 RIB. Change to TD5. RC000. Work even to RC76 (78, 82, 84, 88). Put WY marker at each end. Work even to RC132 (138, 144, 150, 156). Change to TD4. Knit 10 rows, and make 1x1 RIB over these 10 rows. Bind off center 46 (48, 50, 54, 54) sts. Waste knit for both shoulders.

FRONT

Work same as BACK.

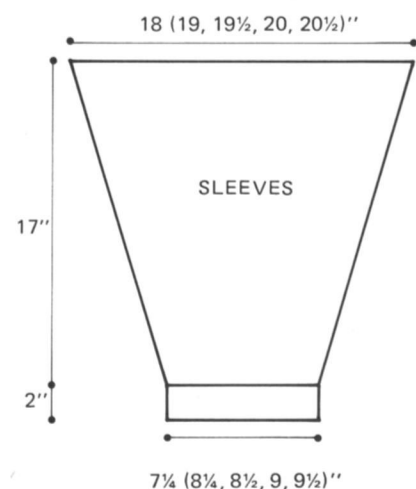

SLEEVES

Using, WY, cast on EON between 19 (20, 21, 22, 23) on each side. Knit a few rows, ending with carr on left. Using MC, finished cast on 38 (40, 42, 44, 46) sts as 1x1 RIB. Knit 16 rows, TD4. Make 1x1 RIB. Change to TD5. RC000. Knit 6 rows. Inc 1 st at each end of next and every foll 6th row 11 (9, 7, 5, 3) times, every 4th row 14 (17, 20, 23, 26) times to 88 (92, 96, 100, 104) sts. Work even to RC126. Waste knit.

FINISHING

With WS up, block and steam pieces omitting ribs. Join both shoulders. Attach sleeves to bodice. Using mattress st, join side and sleeve seams. Give a final steam.

BACK

With WY, cast on 86 (92, 96, 102, 106) sts. Knit a few rows, ending with carr on right. Change to TD7. RC000. Knit to RC60 in lace patt. Knit to RC82 in St st. Put WY marker at each end. Work even to RC146 (150, 152, 156, 158). Put WY

marker on loop between N26 and N27 each side of 0. Waste knit.

FRONT

Knit as for BACK to RC138 (142, 144, 148, 150).

Neck shaping

Bring 56 (59, 61, 64, 66) sts at left into HP. Set HCL to WP. RC000. Knit 1 row. At beg of next and EOR, bind off 6 sts once, 4 sts once, 3 sts once. Knit 3 row and waste knit. Waste knit center 26 sts. Place carr on left. Set HCL to NWP. Knit to match right side of neck, reversing shaping.

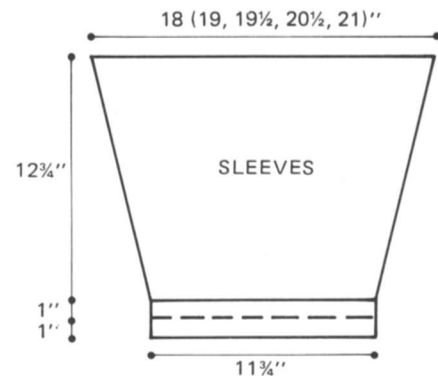

SLEEVES

Using WY, cast on 58 sts. Knit a few rows, ending with carr on right. Change to TD7. RC000. Knit 6 rows. Inc 1 st at each end of next and every foll 6th row 13 (9, 5, 3, 0) times, every 4th rows 2 (8, 14, 17, 22) times to 88 (92, 96, 98, 102) sts until RC40 in lace patt then in St st. Work even to RC90. Waste knit.

FINISHING

With WS up, block and steam pieces. Plain hem for bodice and sleeve:

With WS of bodice facing you, place 76 (82, 86, 90, 96) sts of cast on row with MC decreasing sts evenly onto Ns. *Knit 16 rows at TD5. Place the loops of cast on row onto Ns. Knit 1 row and bind off all sts.*

With WS of sleeve facing you, place 50 sts of cast on row, decreasing sts evenly onto Ns. Work from *to*. Join right shoulder. Collar

With WS facing you, place 52 sts of BACK neck edge and 54 sts along FRONT neck edge onto Ns. Knit 22 rows in St st, TD6. Bind off all sts loosely. Join left shoulder. Attach sleeves to bodice. Join side, sleeve, collar, and hem seams. Give a final steam.

LACE PATTERN

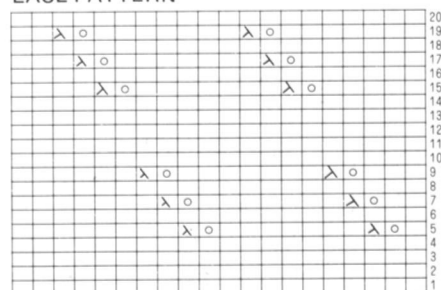



page 4

4. WOMAN'S SUIT

SIZES

Sweater: To fit 32 (34, 36, 38, 40)"/81 (86, 91, 96, 101) cm bust.

Skirt: To fit 34 (36, 38, 40, 42)"/86 (91, 96, 101, 106) cm hips.

Directions are for smaller sizes with larger sizes in parentheses. If there is only one set of figures it applies to all sizes.

KNITTED MEASUREMENTS

Sweater: Finished bust measurement at underarm 36 (38, 40, 42, 44)"/91 (96, 101, 106, 111) cm

Length 20½ (21, 21½, 22, 22¼)"/52.5 (53.5, 54.5, 55.5, 56.5) cm

Skirt: Finished hips measurement 36 (38, 40, 42, 44)"/91 (96, 101, 106, 111) cm
Length including waistband 25½"/65 cm

MATERIALS

Sweater: 7 (8, 8, 9, 9) [1¼ oz/50g] balls of PINGOUIN "Corrida 4" in #506 Yellow (MC)

Skirt: 6 (7, 7, 8, 9) [1¼ oz/50g] balls of "Corrida 4" in #506 Yellow (MC). Waist length of 1" wide elastic

GAUGE/TENSION

* 17 sts and 26 rows to 4"/10 cm in pull-up st patt with TD7.

* 19 sts and 25 rows to 4"/10 cm in St st with TD6.

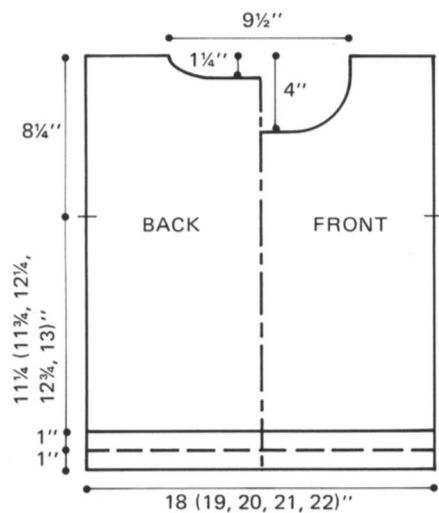

NOTE

* Pull-up st patt for sweater — 6 rows in St st and 2 rows in pull-up st on every 4th N.

* Purl side is right side of fabric.

* Crochet at skirt hem

SWEATER

BACK

Using WY, cast on 78 (82, 86, 90, 94) sts in 1x1 mock rib. Knit a few rows, ending with carr on right. Using MC, knit 20 rows, TD4. Place 1st row of MC cast on loops onto empty Ns. Change to TD7. RC000. Work even to RC76 (78, 80, 82, 86) in pull-up st. Put WY marker at each end. Work even to RC122 (124, 126, 128, 132).

Neck shaping

Waste knit center 26 sts. Waste knit sts at left. Place carr on right. RC000. Knit 1 row. At beg of next and EOR, bind off 4 sts once, 2 sts once, 1 st once. Work even to RC8. Waste knit rem 19 (21, 23, 25, 27) sts. Return sts at left to Ns and place carr on left. Knit left side to match right side, reversing shaping.

FRONT

Knit same as BACK to RC104 (106, 108, 110, 114).

Neck shaping

Waste knit center 14 sts. Waste knit sts at left. Place carr on right. RC000. Knit 1 row. At beg of next and EOR, bind off 3 sts 2 times, 1 st 7 times. Work even to RC26. Waste knit rem 19 (21, 23, 25, 27) sts. Return sts at left to Ns and place carr on left. Knit left side to match right side, reversing shaping.

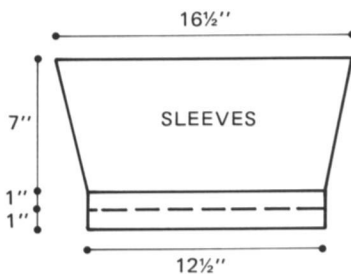

SLEEVES

Using WY, cast on 54 sts in 1x1 mock rib. Knit a few rows, ending with carr on right. Using MC, knit 20 rows, TD4. Place 1st row of MC cast on loops onto empty Ns. Change to TD7. RC000. In pull-up st, knit 6 rows. Inc 1 st at each end, every 6th row 3 times, every 4th row 6 times to 72 sts. Work even to RC48. Waste knit.

FINISHING

With WS up, block and steam pieces omitting ribs. Gathering ribs, steam lightly. Join right shoulder.

Neckband

Using WY, cast on 100 sts in 1x1 mock rib. Knit a few rows, ending with carr on left. Using MC, knit 20 rows, TD4. Place 1st row of MC cast on loops onto empty

Ns. Change to TD2, and knit 1 row. With WS facing you, place 42 sts along BACK neck edge and 58 sts along FRONT neck edge. Knit 1 row, TD4. Bind off all sts.

Join left shoulder. Join side, sleeve and band seams. Give a final steam.

SKIRT (2 pieces)

Using WY, Cast 86 (92, 96, 102, 106) sts. Knit a few rows, ending with carr on right. Change to TD6. RC000. Work even to RC156 in St st. Waste knit.

FINISHING

With WS up, block and steam pieces. With RS facing you, place 76 (82, 86, 92, 96) sts of last row decreasing sts evenly onto Ns. Change to TD5. Knit 16 rows (double length) for waistband. Bind off sts. Join side seams. Turn waistband to inside and into position encasing elastic. Close hemline with crochet and working 1 row single crochet and 1 row backward crochet. Give a final steam.

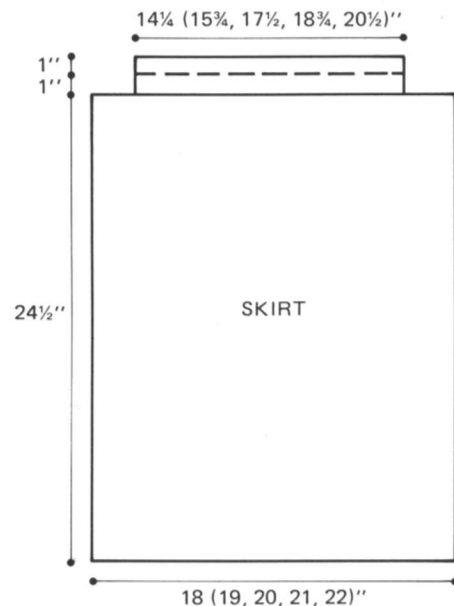

PULL-UP STITCH PATTERN

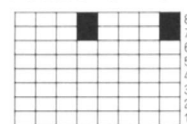

■ Needle in HP



page 5

5. WOMAN'S SUIT

SIZES

To fit 32 (34, 36, 38)"/81 (86, 91, 96) cm bust. To fit 36 (38, 40, 42)"/91 (96, 101, 106) cm hips. Directions are for smaller sizes with larger sizes in parentheses. If there is only one set of figures it applies to all sizes.

KNITTED MEASUREMENTS

- * Sleeveless top: Finished bust measurement at underarm 36 (38, 40, 42)"/91 (96, 101, 106) cm
Length 19½ (19½, 20, 20½)"/49 (50, 51, 52) cm
- * Skirt: Finished hips measurement 54¾ (56¾, 58¾, 60½)"/139 (144, 149, 154) cm
Length including waistband 29½"/75 cm

MATERIALS

- * Sleeveless top: 4 (5, 5, 6) [2 oz/56.7g] skeins of COATS & CLARK RED HEART "Luster Sheen" in #850 Blueberry (MC)
- * Skirt: 10 (10, 11, 12) skeins of "Luster Sheen" in #850 Blueberry (MC)
Waist length of 1" wide elastic

GAUGE/TENSION

25 sts and 27 rows to 4"/10 cm in open st patt with TD2.

NOTE

- * Open st patt — every 8th N at NWP.
- * Crochet at hem, neckline and armhole line.

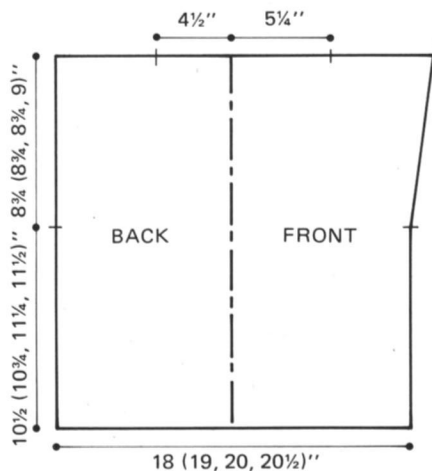

SLEEVELESS TOP BACK

Using WY, cast on 114 (120, 126, 132) sts. Knit a few rows, ending with carr on right. Push every 8th N into NWP. Change to TD2. RC000. Using MC, work even to RC72 (74, 76, 78). Put WY marker at each end. Work even to RC134 (136, 138, 142). Put WY marker on loop between N26 and N27. Waste knit.

FRONT

Knit same as BACK to RC72 (74, 76, 78)
Sleeve shaping
Knit 6 rows. Inc 1 st at each end on next and every foll 6th row 4 (4, 4, 3) times, then every 8th row 4 (4, 4, 5) times. Work even to RC134 (136, 138, 142). Put WY marker on loop between N34 and N35. Waste knit.

FINISHING

With WS up, block and steam. Join both shoulders. Join side seams. Close sts of cast on and last row with crochet, and work 1 row single crochet and 1 row backward crochet. Work single and backward crochet at armhole. Give a final steam.

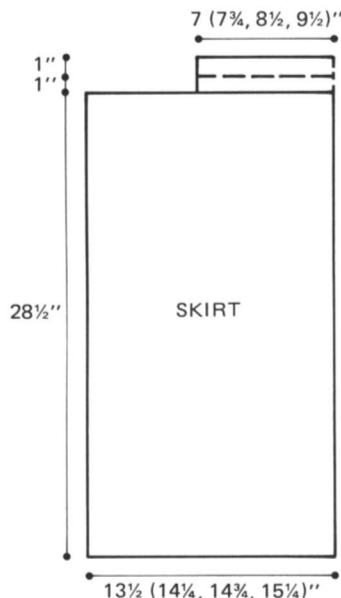

SKIRT (4 pieces)

With WY, cast on 86 (90, 94, 96) sts. Knit a few rows, ending with carr on right. Push every 8th N into NWP. Change to TD2. RC000. Using MC, Work even to RC196. Waste knit.

FINISHING

With WS up, block and steam. Join side seams of 2 pieces. With WS facing you, place 90 (98, 116, 124) sts onto Ns decreasing sts evenly. Knit 16 rows in St st, TD2. Bind off sts. Join side seams. Turn waistband to inside and st into position encasing elastic. Close sts of hemline with crochet and work 1 row single, and 1 row backward crochet. Give a final steam.

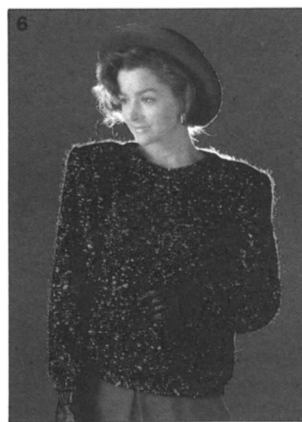

page 6

6. WOMAN'S SET-IN SLEEVE SWEATER

SIZES

To fit 34 (36, 38, 40, 42)"/86 (91, 96, 101, 106) cm bust. Directions are for smaller sizes with larger sizes in parentheses. If there is only one set of figures it applies to all sizes.

KNITTED MEASUREMENTS

- * Finished bust measurement at underarm 38 (40, 42, 44, 46)"/96 (101, 106, 111, 116) cm.
- * Length 22 (23½, 24½, 25¼, 26)"/58 (60, 62, 64, 66) cm

MATERIALS

10 (11, 11, 12, 12) [1¼ oz/50g] balls of PHILDAR "Geolite" in #67 Black (MC)

GAUGE/TENSION

15 sts and 20 rows to 4"/10 cm in St st with TD9.

NOTE

- * Purl side is right side of fabric.
- * Plain hems are used right side.

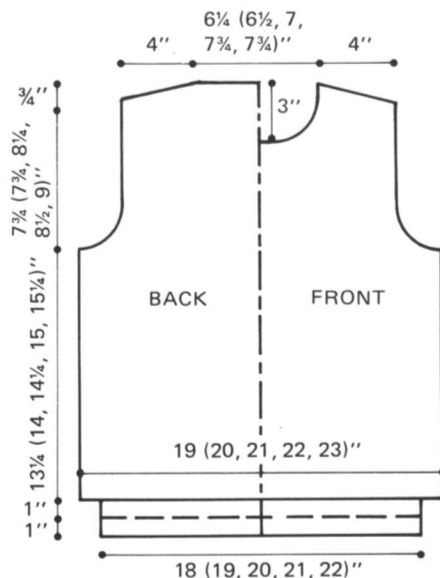

BACK

Using WY, cast on 72 (76, 80, 84, 88) sts. Knit a few rows, ending with carr on right. Change to TD9. RC000. Using MC, work even to RC68 (72, 74, 76, 78).

Armhole shaping.

At beg of next and EOR at each end, bind off 3 sts 2 times, 2 sts 0 (1, 1, 1, 3) time, then 1 st 3 (2, 3, 4, 2) times. Work even to RC108 (112, 116, 120, 124).

Shoulder shaping

Set HCL to WP. At side opposite carr bring 5 Ns into HP. (Always taking yarn round inside N) knit 1 row. Repeat from *to* 4 times to RC112 (116, 120, 124, 128). Waste knit center 24 (26, 28, 30, 30) sts. Waste knit rem 15 sts each side for shoulders.

FRONT

Knit same as BACK to RC98 (102, 106, 110, 114).

Neck shaping

Bring 31 (33, 34, 35, 35) at left into HP. Set HCL to WP. RC000. Knit 1 row. At beg of next and EOR, bind off 3 sts 1 (1, 2, 1, 1) time, 2 sts 1 (1, 0, 3, 3) time, then 1 st 3 (3, 3, 1, 1) times.

Shoulder shaping

Knit 2 rows. At side opposite carr bring 5 Ns into HP. (Always taking yarn round inside N) Repeat from **to** 2 times to RC15. Return 15 Ns at right into WP. Waste knit. Waste knit center 8 (10, 10, 10, 10) sts. Place carr on left. Knit to match right side reversing shaping.

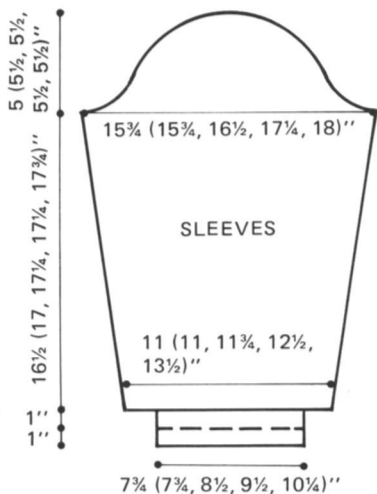

SLEEVES

Using WY, cast on 42 (42, 46, 48, 52) sts. Knit a few rows, ending with carr on right. Inc 1 st at each end of next and every foll 8th row 7 (6, 5, 5, 4) times, every 10th row 2 (3, 4, 4, 5) times to 60 (60, 64, 66, 70) sts. Work even to RC84 (86, 88, 88, 90).

Sleeve cap shaping

At beg of next and every row, bind off 4 sts twice, 2 sts 10 (6, 8, 12, 10) times, then 1 st 10 (14, 12, 10, 8) times. Knit 2 rows. At beg of next and every row, bind off 2 sts 2 (4, 4, 2, 6) times, then 3 sts twice. Bind off rem 12 (12, 14, 14, 16) sts.

FINISHING

With WS up, block and steam pieces. With WS of bodice facing you, hang 64 (68, 72, 76, 78) sts of cast on row decreasing sts evenly. ***Change to TD7. RC000. Knit 7 rows. Knit 1 row, TD9. Change to TD7. Knit 7 rows, and bind off all sts loosely.*** With WS of sleeve facing you, hang 34 (34, 38, 40, 44) sts onto Ns decreasing sts evenly. Work from ***to***. Join right shoulder. With WS of bodice facing you, hang 24 (26, 28, 30, 30) sts of BACK neck edge and 46 (46, 46, 48, 48) sts along FRONT neck edge. Work from ***to***. Join left shoulder. Join neckband seam. Plain hems, slip-stitched down into position. Set in sleeves. Join side and sleeve seams. Give a final steam.

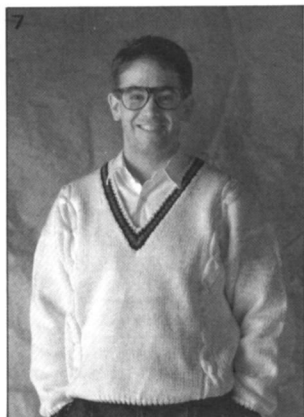

page 19

7. MAN'S V-NECK SWEATER

SIZES

To fit 38 (40, 42, 44)"/96 (101, 106, 111) cm chest.

Directions are for smaller sizes with larger sizes in parentheses. If there is only one set of figures it applies to all sizes.

KNITTED MEASUREMENTS

* Finished chest measurement at under-arm 41 (43, 45, 47)"/104 (109, 114, 119) cm.

* Length 23 1/2 (24 1/2, 25 1/2, 26 1/2)"/60 (62.5, 65, 67.5) cm.

* Sleeve width at upper arm 20 (20 1/2, 21, 22)"/50 (52, 54, 56) cm.

MATERIALS

* 6 (7, 7, 8) [3 1/2 oz/99.2g] skeins of COATS & CLARK RED HEART "wintuk" in #3 Off White (MC).

* 1 each skein of "wintuk" in #860 Medium Navy (CC1), #917 Cardinal (CC2).

GAUGE/TENSION

17 sts and 26 rows to 4"/10 cm in St st with TD9.

NOTE

* Finished cast on 1x1 RIB Refer to METHOD on page 7.

* Cabled effect is given at FRONT.

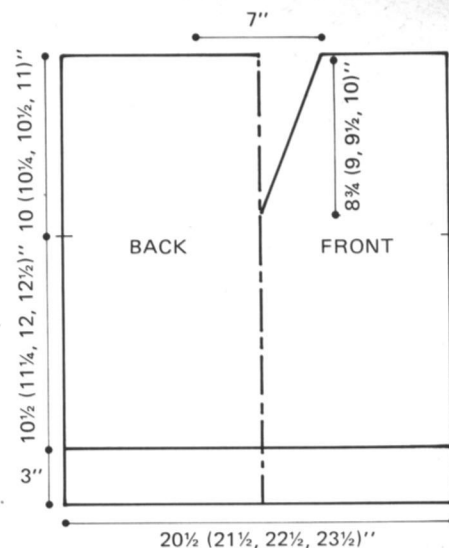

BACK

Using WY, cast on EON between 44 (46, 48, 51) at each side. Knit a few rows, ending with carr on left. Using MC, finished cast on 88 (92, 96, 102) sts as 1x1 RIB. Change to TD7. RC000. *Knit 2 rows with MC. Knit 4 rows with CC1, 4 rows with CC2, 4 rows with CC1, then 4 rows with MC until RC18. Make 1x1 RIB.* Change to TD9. RC000. Work even to RC72 (76, 80, 84). Put WY marker at each end. Work even to RC136 (142, 150, 156). Put WY marker on loop between N15 and N16. Waste knit.

FRONT

Knit same as BACK to RC78 (82, 88, 90) AT THE SAME TIME every 20th row reverse with latching tool on Ns 25, 26, 33, 34 on each side.

Neck shaping

Waste knit sts at left. Place carr on right. RC000. Knit 1 row. Dec 1 st at neck edge on next and every foll 4th row 13 (14, 15, 15) times, EOR 2 (1, 0, 0) times. Work even to RC58 (60, 62, 66). Waste knit rem sts. Return sts at left to Ns. Place carr on left and knit to match right side reversing shaping.

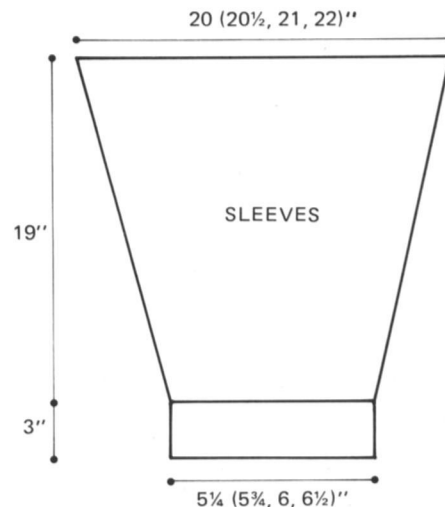

SLEEVES

Using WY, cast on EON between 23 (24, 26, 28) at each side. Knit a few rows, ending with carr on left. Using MC, finished cast on 46 (48, 52, 56) sts as 1x1 RIB. Work from *to*. Change to TD9. RC000. Knit 6 rows. Inc 1 st at each end of next and every foll 6th rows 20 times to 86 (88, 92, 96) sts. Work even to RC124. Waste knit.

NECKBANDS

NECKBAND for BACK and right FRONT (A)

Using WY, cast on EON between 35 (36, 37, 38) at each side. Knit a few rows, ending with carr on left. Using MC, finished cast on 70 (72, 74, 76) sts as 1x1 RIB. Change to TD7. RC000. Knit 1 row with MC, 2 rows with CC1, 2 rows with CC2, 2 rows with CC1, then 1 row with MC. Make 1x1 RIB. Waste knit. NECKBAND for left FRONT (B)

Knit same as NECKBAND (A), using 40 (42, 44, 46) sts.

FINISHING

With WS up, block and steam pieces omitting ribs. Join right shoulder. With RS of neckband (A) facing you, hang 70 (72, 74, 76) sts. With WS of bodice facing you, hang 30 sts of BACK neck edge and 40 (42, 44, 46) sts along right FRONT neck edge. Knit 1 row and bind off sts. Attach neckband (B) to left FRONT neck edge. Join left shoulder. Attach sleeves to bodice. Join side, sleeve and neckband seams. Join neckband seams making miter at center FRONT. To give a cabled effect, catch every 16th row with MC. Give a final steam.

CABLED EFFECT

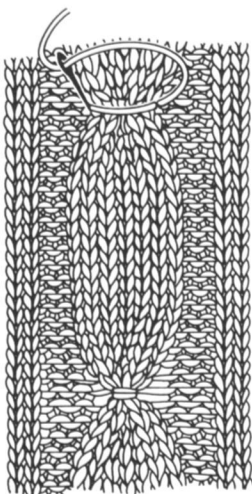

page 20

8. MAN'S V-NECK CARDIGAN

SIZES

To fit 38 (40, 42, 44)"/96 (101, 106, 111) cm chest.

Directions are for smaller sizes with larger sizes in parentheses. If there is only one set of figures it applies to all sizes.

KNITTED MEASUREMENTS

* Finished chest measurement 41 (43, 45, 47)"/104 (109, 114, 119) cm

* Length 23½ (24¾, 26, 27¼)"/60 (63, 66, 69) cm

* Sleeve width at upper arm 20 (20½, 21, 22)"/50 (52, 54, 56) cm

MATERIALS

* 7 (7, 8, 9) [3½ oz/99.2 g] skeins of COATS & CLARK RED HEART "wintuk" in #360 Wood Brown (MC)
* 5 shank buttons

GAUGE/TENSION

17 sts and 26 rows to 4"/10 cm in St st with TD9.

Work even to RC70 (76, 82, 88). Put WY marker at each end. Work even to RC136 (144, 152, 160). Put WY marker on loop between N19 and N20. Waste knit.

RIGHT FRONT

Using WY, cast on 41 (44, 47, 50) sts. Work from *to*. Work even to RC70 (76, 82, 88). Put WY marker at each end. Knit 1 row. Dec 1 st at neck edge of next and EOR 2 (1, 1, 0) times, every 4th row 15 (16, 16, 17) times. Work even to RC136 (144, 152, 160). Waste knit.

LEFT FRONT

Knit same as right FRONT reversing shaping.

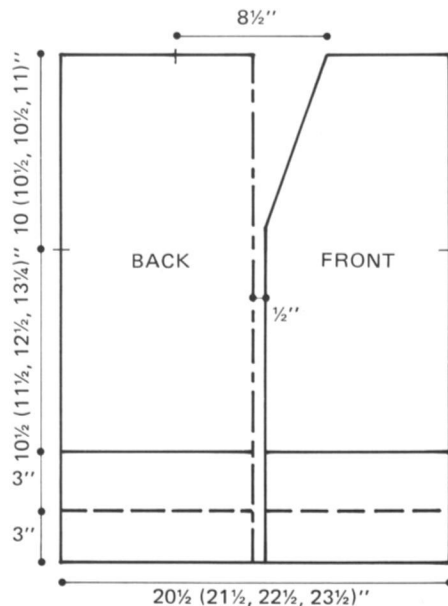
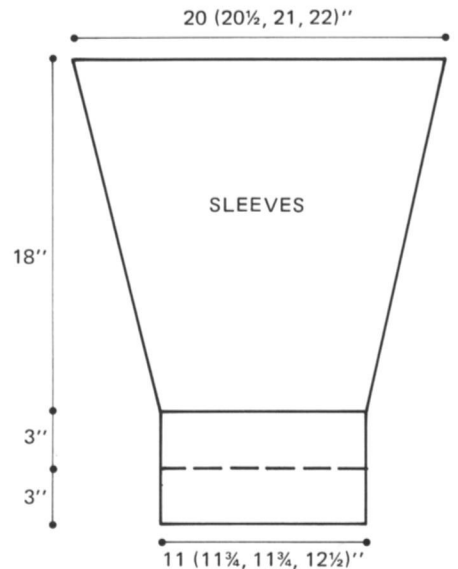

BACK

Using WY, cast on 86 (92, 98, 104) sts. *Knit a few rows, ending with carr on right. Push every 3rd N into NWP. Change to TD6. RC000. Using MC, knit 40 rows. Push empty Ns into WP. Place row of cast on loops with MC to corresponding Ns. Change to TD9. RC000. (Inc 1 st when total number is odd).*

SLEEVES

Using WY, cast on 47 (53, 53, 53) sts. Work from *to*. Knit 6 rows. Inc 1 st at each end of next and every 6th row 19 (18, 18, 16) times, every 4th row 0 (0, 2, 5) times. Work even to RC120. Waste knit.

FINISHING

With WS up, block and steam pieces omitting 2x1 mock ribs. Gathering ribs, steam lightly. Join both shoulders.

Neckband

Using WY, cast on 38 sts. **Knit a few rows, ending with carr on left. Push every 3rd N into NWP. Change to TD6. RC000. Knit 16 rows with MC. Push empty Ns into WP. Hang row of cast on loops with MC onto Ns. Knit 1 row, TD5.** With WS of BACK facing you, hang 38 sts of BACK neck edge onto Ns. Knit 1 row and bind off all sts.

Front bands

Using WY, cast on 104 (110, 116, 119) sts. Work from **to**. With WS of FRONT facing you, hang 104 (110, 116, 119) sts evenly along FRONT opening onto Ns. Knit 1 row and bind off all sts. Attach sleeves to bodice. Join side, sleeve and band seams. Attach shank buttons on front bands. Give a final steam.

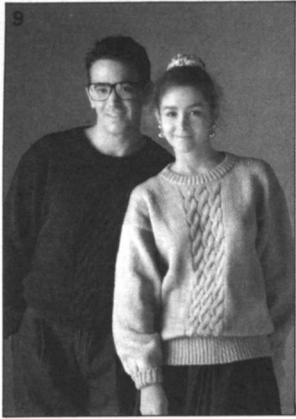

page 21

9. MAN'S OR WOMAN'S OVERSIZED SWEATER

SIZES

To fit 32 (34, 36, 38, 40, 42, 44)"/81 (86, 91, 96, 101, 106, 111) cm bust/chest. Directions are for smaller sizes with larger sizes in parentheses. If there is only one set of figures it applies to all sizes.

KNITTED MEASUREMENTS

- * Finished bust/chest measurement at underarm 40 (42, 44, 46, 48, 50, 52)"/101 (106, 111, 116, 121, 126, 131) cm
- * Length 23½ (24½, 24¾, 25½, 26½, 26¾, 27¼)"/59.5 (61.5, 63, 65, 67, 68, 69) cm
- * Sleeve width at upper arm 18 (19, 19½, 20½, 20¾, 21, 22)"/46 (48, 50, 52, 52, 54, 56) cm

MATERIALS

6 (7, 7, 8, 8, 9, 9) [3½ oz/99.2 g] skeins of COATS & CLARK RED HEART 4PLY "wintuk" in #746 Cherry Pink (MC) or in #860 Medium Navy (MC).

GAUGE/TENSION

17 sts and 26 rows to 4"/10 cm in St st with TD9.

NOTE

- * Finished cast on for 1x1 RIB.
- Refer to METHOD on page 7.
- * Cable st is knitted on FRONT only.

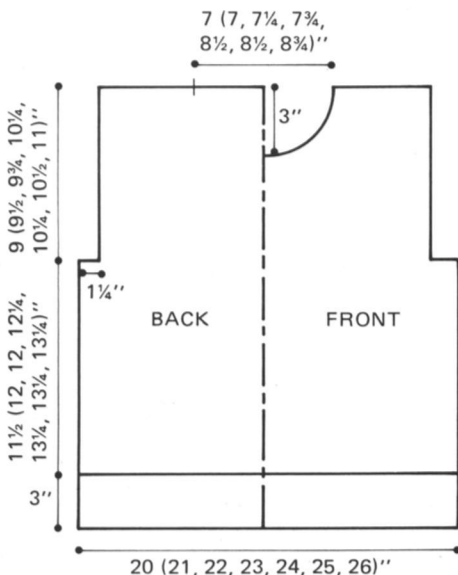

BACK

Using WY, cast on EON between 43 (45, 48, 49, 51, 53, 55) at each side. Knit a few rows, ending with carr on left. Using MC, finished cast on 86 (90, 96, 98, 102, 106, 110) sts as 1x1 RIB. Knit 20 rows, TD7. Make 1x1 RIB. Change to TD9. RC000. Work even to RC76 (78, 82, 82, 86, 86, 86).

Armhole shaping

At beg of next 2 rows, bind off 5 sts.

Work even to RC136 (140, 144, 150, 154, 156, 160).

Put WY marker on loop between N15 (15, 16, 17, 18, 18, 19) and N16 (16, 17, 18, 19, 19, 20). Waste knit.

FRONT

Work 1x1 RIB same as BACK.

Change to TD9. RC000. Transfer sts of N4 and N11 at each side to adjacent Ns. Push empty Ns into NWP. Knit to RC116 (120, 124, 130, 134, 136, 140) same as BACK, making cable st every 5 rows.

Neck shaping

Waste knit center 10 (10, 12, 12, 12, 12, 14) sts. Bring sts at left to HP. Set HCL to WP. RC000. Knit 1 row. At beg of neck edge on next and EOR, dec 3 sts 1 (1, 1, 2, 2, 2, 2) time, 2 sts 1 (1, 1, 0, 1, 1, 1) time, 1 st 5 (5, 5, 5, 5, 4, 4) times. Work even to RC20. Waste knit rem sts on right. Place carr on left. Set HCL to NWP. Knit to match right side reversing shaping.

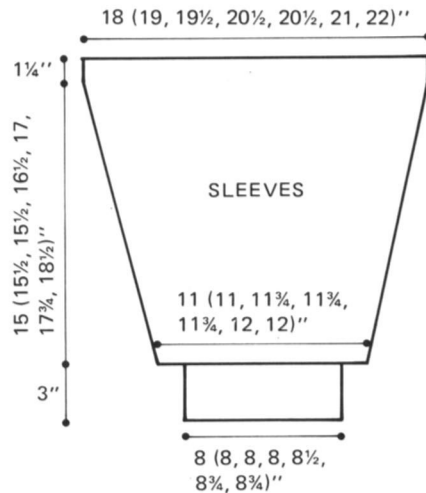

CABLE STITCH PATTERN

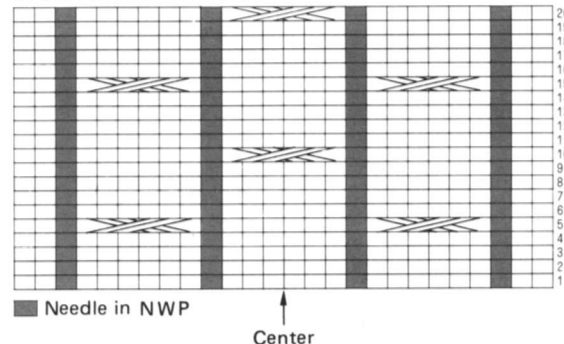

SLEEVES

With WY, cast on 48 (48, 50, 50, 50, 52, 52) sts. Knit a few rows, ending with carr on right. Change to TD9. RC000. Using MC, knit 6 rows. Inc 1 st at each end of next and every foll 6th row 15 (15, 14, 14, 16, 17, 15) times, then every 4th row 0 (2, 4, 5, 3, 3, 7) times to 78 (82, 86, 88, 88, 92, 96) sts. Work even to RC100 (104, 104, 110, 112, 118, 122). Waste knit. Put WY marker at each end. Knit 8 rows, and waste knit.

CUFFS (2 pieces)

With WY, cast on EON between 17 (17, 17, 18, 19, 19) at each side. Knit a few rows, ending with carr on left. Using MC, finished cast on 34 (34, 34, 34, 36, 38, 38) sts for 1x1 RIB. Knit 20 rows with TD7. Make 1x1 RIB. Waste knit.

FINISHING

With WS up, block and steam pieces omitting ribs. With RS of cuff facing you, hang sts onto Ns. With WS of sleeve facing you, hang sts of same number as cuff onto Ns decreasing sts evenly. Knit 1 row, and bind off sts. Join right shoulder.

Neckband

With WY, cast on EON between 38 (38, 40, 42, 43, 43, 45) at each side. Knit a few rows, ending with carr on left. Using MC, finished cast on 76 (76, 80, 84, 86, 86, 90) as 1x1 RIB. Knit 10 rows, TD7. Make 1x1 RIB. Waste knit.

With RS facing you, hang 30 (30, 32, 34, 36, 36, 38) sts of BACK neck edge and 46 (46, 48, 50, 50, 50, 52) sts along FRONT neck edge. With WS facing you, hang sts of neckband onto Ns. Knit 1 row. Bind off all sts. Join left shoulder. Attach sleeves to bodice. Join armhole and neckband seams. Join side and sleeve seams. Give a final steam.

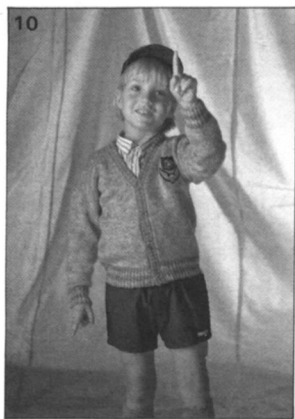

page 22

10. BOY'S V-NECK CARDIGAN

SIZES

To fit 23 (25, 27)"/58 (63, 68) cm chest. Directions are for smaller sizes with larger sizes in parentheses. If there is only one set of figures it applies to all sizes.

KNITTED MEASUREMENTS

- * Finished chest measurement at underarm 26 (28, 30)"/66 (71, 76) cm
- * Length 15 (17½, 19)"/40 (44, 48) cm

MATERIALS

- * 4 (5, 6) [1½ oz/50g] balls of PHILDAR "BRISANTS 030" in #44 Gypse (MC)
- * 1 ball of "BRISANTS 030" in #18 Bure (CC)
- * 4 buttons

GAUGE/TENSION

21 sts and 28 rows to 4"/10 cm in St st with TD5.

NOTE

- * Finished cast on for 1x1 RIB. Refer to METHOD on page 7.

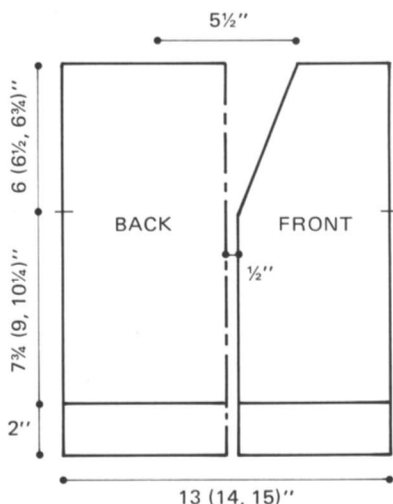

BACK

Using WY, cast on EON between 35 (37, 40) at each side. Knit a few rows, ending with carr on left. Using CC, finished cast on 70 (74, 80) sts as 1x1 RIB. Knit 16 rows, changing MC and CC every 4th row, TD3. Make 1x1 RIB. Change to TD5. RC000. Work even to RC56 (64, 74). Put WY marker at each end. Work even to RC98 (110, 126). Put WY marker on loop between N15 and N16. Waste knit.

RIGHT FRONT

Using WY, cast on EON between 1 and 34 (36, 38) on right. Knit a few rows, ending with carr on left. Using CC, finished cast on 34 (36, 38) sts as 1x1 RIB. Knit 16 rows, changing MC and CC every 4th row, TD3. Make 1x1 RIB. Change to TD5. RC000. Work even to RC56 (64, 74). Put WY marker at right end.

Neck shaping

Knit 1 row. Dec 1 st at left end of next and EOR 8 (6, 3) times, every 4th row 6 (8, 10) times. Work even to RC98 (110, 120). Waste knit.

LEFT FRONT

Knit same as RIGHT FRONT reversing shaping.

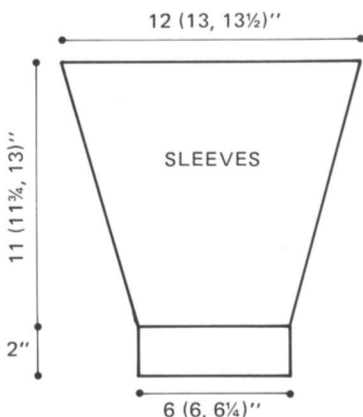

SLEEVES

Using WY, cast on EON between 16 (16, 18) at each side. Knit a few rows, ending with carr on left. Using CC, finished cast on 32 (32, 36) sts as 1x1 RIB. Knit 16 rows, changing MC and CC every 4th row, TD3. Make 1x1 RIB. Change to TD5. RC000. Knit 6 rows. Inc 1 st at each end of next and every foll 6th row 5 (4, 6) times, every 4th row 11 (14, 13) times to 64 (68, 74) sts. Work even to RC78 (84, 92). Waste knit.

NECKBAND

Using WY, cast on EON between 15 at each side. Knit a few rows, ending with carr on left. Using CC, finished cast on 30 sts as 1x1 RIB. Make 1x1 RIB. Change to TD5. RC000. Knit 8 rows, changing MC and CC every 2nd row. Waste knit.

BUTTONBAND

Knit same as NECKBAND with 76 (84, 92) sts.

BUTTONHOLE BAND

Knit same as BUTTONBAND, work 4x1 st buttonholes on row 4.

FINISHING

With WS up, block and steam pieces omitting ribs. Join both shoulders. With RS of neckband facing you, hang 30 sts onto Ns. With WS of BACK facing you, hang 30 sts of neck edge. Knit 1 row and bind off all sts. With RS of buttonband facing you, hang 76 (84, 92) sts onto Ns. With WS of RIGHT FRONT facing you, hang 76 (84, 92) sts along FRONT open-

ing. Knit 1 row and bind off sts. Attach buttonhole band to LEFT FRONT same as buttonband. Attach sleeves to bodice. Join side and sleeve seams. Sew on buttons. Give a final steam.



page 22

11. GIRL'S CREW NECK CARDIGAN

SIZES

To fit 23 (25, 27)"/58 (63, 68) cm chest. Directions are for smaller sizes with larger sizes in parentheses. If there is only one set of figures it applies to all sizes.

KNITTED MEASUREMENTS

- * Finished chest measurement at underarm 26 (28, 30)"/66 (71, 76) cm
- * Length 15 (17½, 19)"/40 (44, 48) cm

MATERIALS

- * 3 (3, 4) [3½ oz/99.2g] skeins of COATS & CLARK RED HEART 4PLY "wintuk" in #245 Orange (MC)
- * 1 skein of "wintuk" in #1 White (CC).
- * Five buttons

GAUGE/TENSION

17 sts and 26 rows to 4"/10 cm in St st with TD9.

NOTE

- * Stripe patt — 10 rows with MC and 2 rows with CC
- * Purl side is right side of fabric.
- * Finished cast on for 1x1 RIB. Refer to METHOD on page 7.

BACK

Using WY, cast on EON between 28 (30, 32) at each side. Knit a few rows, ending with carr on left. Using CC, finished cast on 56 (60, 64) sts as 1x1 RIB. Using MC, knit 14 rows, TD7. Make 1x1 RIB. Change to TD9. RC000. Knit in stripe to RC52 (58, 68). Put WY marker at each end. Work even to RC90 (100, 110). Put WY marker on loop between N12 and N13. Waste knit.

RIGHT FRONT

Using WY, cast on EON between 1 and 26 (28, 30) on right. Knit a few rows, ending with carr on left. Using CC, finished cast on 26 (28, 30) sts as 1x1 RIB. Using MC, knit 14 rows, TD7. RC000. Knit in stripe to RC52 (58, 68). Put WY marker at right end. Work even to RC74 (84, 92).

Neck shaping

Knit 1 row. At beg of next and EOR at left edge, bind off 4 sts once, 2 sts once, 1 st 4 times. Work even to RC90 (100, 110). Waste knit rem sts.

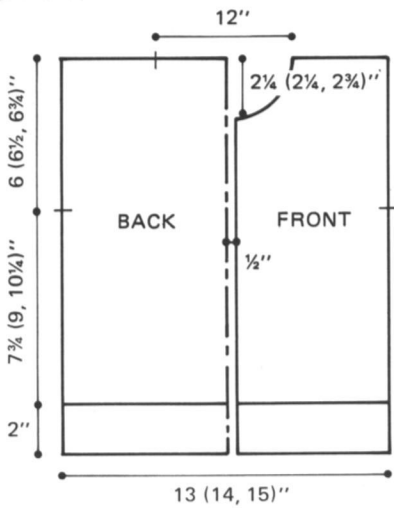

LEFT FRONT

Knit same as RIGHT FRONT reversing shaping.

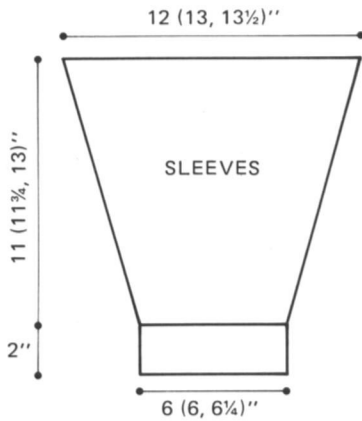

SLEEVES

Using WY, cast on EON between 13 (13, 14) at each side. Knit a few rows, ending with carr on left. Using CC, finished cast on 26 (26, 28) sts as 1x1 RIB. Using MC, knit 14 rows, TD7. Make 1x1 RIB. Change to TD9. RC000. Work in stripe. Knit 6 rows. Inc 1 st at each end of next and every foll 6th row 8 (9, 10) times, every 4th row 5 times to 52 (54, 58) sts. Work even to RC72 (78, 84). Waste knit.

NECKBAND

Using WY, cast on EON between 32 (32, 34) at each side. Knit a few rows, ending with carr on right. Using CC, finished cast on 64 (64, 68) sts, as 1x1 RIB. Using MC, knit 6 rows, TD7. On row 3, work 1 st buttonhole at 5th N from right edge. Make 1x1 RIB. Waste knit.

BUTTONBAND

Using WY, cast on EON between 31 (34, 37) at each side. Knit a few rows, ending with carr on right. Using CC, finished cast on 62 (68, 74) sts, as 1x1 RIB. Using MC, knit 6 rows, TD7. Make 1x1 RIB. Waste knit.

BUTTONHOLE BAND

As BUTTONBAND, work 4 x 1 st buttonholes on row 3.

FINISHING

With WS up, block and steam pieces omitting ribs. Join both shoulders. With RS of LEFT FRONT facing you, hang 62 (68, 74) sts along FRONT opening edge onto Ns. Place buttonband and bind off sts. Attach buttonhole band to RIGHT FRONT same as buttonband. With RS facing you, pick up each 20 (20, 24) sts evenly along FRONT neck edge and 24 sts between WY markers of BACK. Place neckband and bind off sts. Join side and sleeve seams. Attach buttons. Give a final steam.

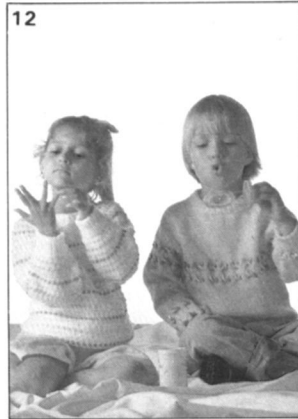

page 23

12. GIRL'S RAGLAN SWEATER

SIZES

To fit 25 (26 1/2, 28 1/2, 30)"/63.5 (67.5, 72, 76) cm chest.

Directions are for smaller sizes with larger sizes in parentheses. If there is only one set of figures it applies to all sizes.

KNITTED MEASUREMENTS

* Finished chest measurement at underarm 28 (29 1/2, 31 1/2, 33)"/71 (75, 80, 84) cm

* Length 18 1/2 (20, 21 1/2, 23 1/4)"/47 (51, 55, 59) cm

MATERIALS

* 3 (3,4,4) [3 oz/85g] balls of COATS & CLARK RED HEART "super sport yarn" in #736 Bright Pink (MC)

* 1 each ball of "super sport yarn" in #1 White (CC1), #263 Maize (CC2), and #819 Blue Jewel (CC3).

GAUGE/TENSION

19 sts and 38 rows to 4"/10 cm in multi-color pull-up st patt with TD6.

NOTE

* Multi-color pull-up every other st patt — 4 rows in St st with MC, 2 rows in pull-up st with CC.

BACK

Using WY, cast on 68 (71, 77, 80) sts. *Knit a few rows, ending with carr on right. Push every 3rd Ns into NWP. Change to TD3. RC000. Using MC, knit 32 rows. Push empty Ns into WP. Place row of cast on loops with MC onto Ns. Change to TD6. RC000. (Inc 1 st in case of odd number). * Work even to

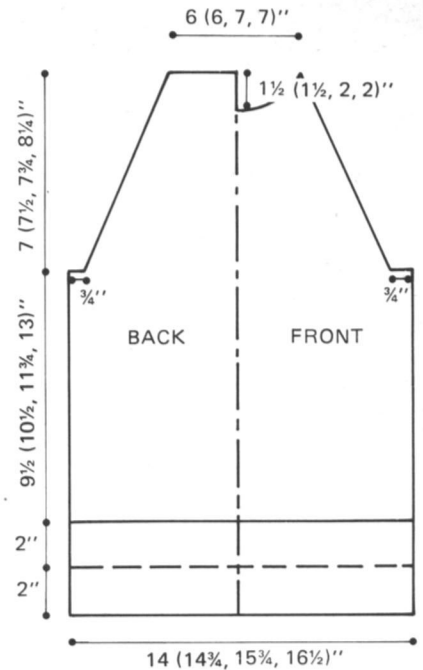

RC92 (104, 114, 126) in pull-up st patt. Armhole shaping

At beg of next 2 rows, bind off 4 sts. Raglan shaping

Dec 1 st at each end of next and EOR 0 (1, 3, 3) time, every 4th row 16 (17, 17, 18) times. Work even to RC160 (178, 192, 208). Waste knit rem 28 (28, 30, 30) sts.

FRONT

Knit same as BACK to RC144 (162, 172, 188). Raglan shaping AT THE SAME TIME ...

Neck shaping

RC000. Waste knit center 10 sts. Waste knit sts at left. Knit 1 row. At beg of next and EOR, dec 2 sts 3 times, 1 st 3 (3, 4, 4) times to RC16 (16, 20, 20). Return sts at left into Ns. Place carr on left. Knit to match right side reversing shaping.

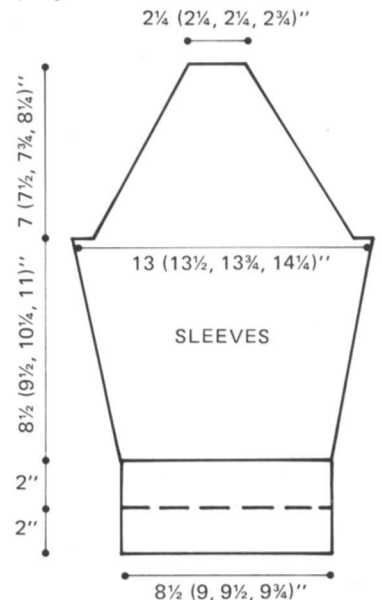

SLEEVES

Using WY, cast on 41 (44, 47, 50) sts. Work from *to*. Knit 8 rows. Inc 1 st at each end of next and every foll 8th row 10 (8, 4, 1) times, every 10th row 0 (2, 6, 9) times. Work even to RC84 (92, 100, 106). At beg of next 2 rows, bind off 4 sts.

Raglan shaping

Dec 1 st at each end of next and EOR 9 (9, 9, 7) times, then every 4th row 12 (13, 14, 16) times to RC152 (164, 176, 186). Waste knit rem 12 (12, 14, 16) sts.

FINISHING

With WS up, block and steam pieces omitting 2x1 mock ribs. Gathering ribs, steam lightly. Join raglan seams leaving left back seam open.

Neckband

With WY, cast on 86 (86, 95, 101) sts. Knit a few rows, ending with carr on left. Make 2x1 mock rib of 16 rows. Knit 1 row, TD1. With WS facing you, hang 28 (28, 30, 30) sts of BACK neck edge, 34 (34, 37, 39) sts along FRONT neck edge and each 12 (12, 14, 16) sts of SLEEVES onto Ns. Knit 1 row, TD3. Bind off all sts. Join raglan and neckband seams. Join armhole seams. Join side and sleeve seams. Give a final steam.

MULTI-COLOR STITCH PATTERN

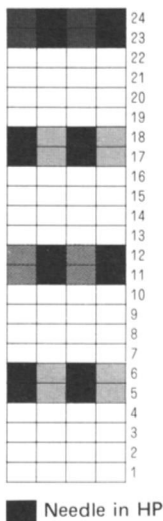

MC
CC1
CC2
CC3

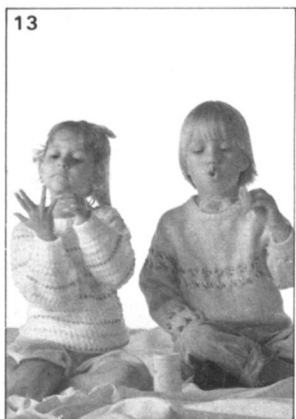

page 23

13. BOY'S RAGLAN SWEATER

SIZES

To fit 25 (27, 28½, 30)"/63.5 (68.5, 72, 76) cm chest. Directions are for smaller sizes with larger sizes in parentheses. If there is only one set of figures it applies to all sizes.

KNITTED MEASUREMENTS

* Finished chest measurement at underarm 28 (30, 31½, 33)"/71 (76, 80, 84) cm
* Length 18½ (20, 21½, 23¼)"/47 (51, 55, 59) cm

MATERIALS

*3 (4, 4, 5) [3 oz/85 g] balls of COATS & CLARK RED HEART "super sport yarn" in #263 Maize (MC)
*1 each ball of "super sport yarn" in #1 White (CC1), and #819 Blue Jewel (CC2).

GAUGE/TENSION

21 sts and 30 rows to 4"/10 cm in St st with TD6.

NOTE

* Cords are decorated.

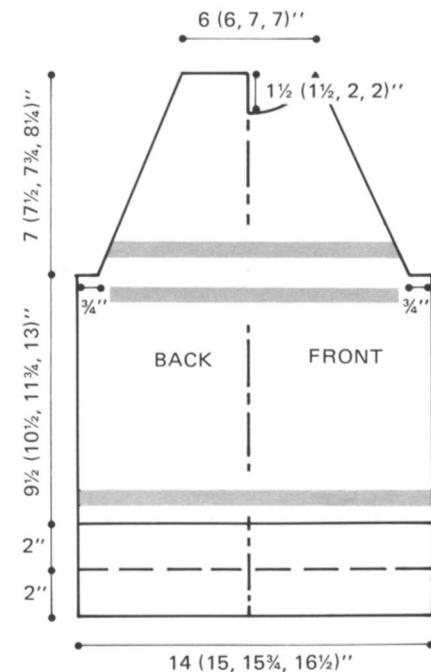

BACK

Using WY, cast on 77 (80, 86, 89) sts. *Knit a few rows, ending with carr on right. Push every 3rd N into NWP. Change to TD3. RC000. Using MC, knit 32 rows. Push empty Ns into WP. Hang row of cast on loops with MC on Ns. Change to TD6. RC000. (Inc 1 st when total number is odd.)* Work even to RC72 (82, 90, 100).

Armhole shaping

At beg of next 2 rows, bind off 5 sts.

Raglan shaping

Dec 1 st at each end of next and EOR 10 (10, 13, 15) times, then every 4th row 8 (9, 8, 8) times. Work even to RC128 (142, 152, 166). Waste knit rem 32 (32, 34, 34) sts.

FRONT

Knit same as BACK to RC116 (130, 136, 150). Raglan shaping AT THE SAME TIME ...

Neck shaping

Set HCL to WP. Waste knit center 12 sts. Bring Ns at left into HP. Place carr on right. RC000. Knit 1 row. At beg of next and EOR, bind off 3 sts 2 (2, 1, 1) times, 2 sts 1 (1, 2, 2) time, 1 st 2 (2, 4, 4) times. Knit 1 row to RC12 (12, 16, 16). Place carr on left. Set HCL to NWP. Knit to match right side reversing shaping.

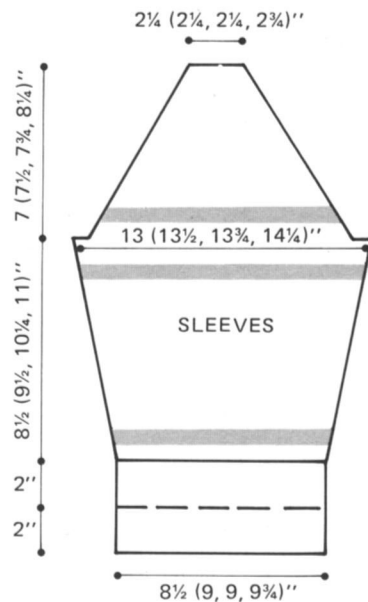

Position for CORD

SLEEVES

Using WY, cast on 47 (50, 50, 53) sts. Work from * to *. Knit 4 rows. Inc 1 st at each end of next and every foll 4th row 2 (0, 0, 0) times, every 6th row 9 (11, 8, 5) times, every 8th row 0 (0, 3, 6) times to 70 (72, 72, 76) sts. Work even to RC66 (72, 78, 84). At beg of next 2 rows, bind off 5 sts.

Raglan shaping

Knit 2 rows. Dec 1 st at each end of next and EOR 21 (20, 20, 19) times, every 4th row 2 (4, 4, 6) times. Work even to RC122 (132, 140, 150). Waste knit rem 14 (14, 14, 16) sts.

CORD (Tube knitting)

Using CC, Cast on 2 sts TD3. Set either PL to WP. Knit approx 200 rows, and bind off sts. Knit each 12 cords using CC1 and CC2.

FINISHING

With WS up, block and steam pieces omitting 2x1 mock rib. Gathering ribs, steam lightly. Join raglan seams leaving left back seam open.

Neckband

With WY, cast on 95 (95, 104, 107) sts. Knit a few rows, ending with carr on left. Push every 3rd N into NWP. Change to TD3. RC000. Using MC, make 2x1 mock rib of 16 rows. Knit 1 row, TD1. With WS facing you, hang 32 (32, 34, 34) sts of BACK neck edge, 35 (35, 42, 41) sts along FRONT neck edge and each 14 (14, 14, 16) sts of SLEEVES onto Ns. Knit 1 row, TD3. Bind off all sts. Join raglan and neckband seams. Join armhole seams. Join side and sleeve seams. Put CORDS through BODICE and SLEEVES according to diagram. Give a final steam.

HOW TO PLACE IN CORDS

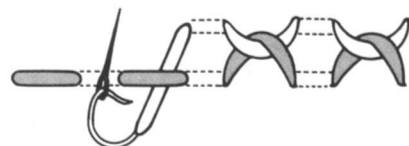

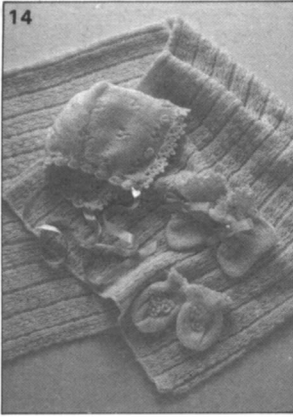

14. BABY'S ITEMS

BLANKET

KNITTED MEASUREMENTS

* Length 40"/100 cm Width 34"/86 cm

MATERIALS

5 [2 oz/56.7 g] skeins of COATS & CLARK RED HEART "pompadour yarn" in #680 Pastel Green (MC)

GAUGE/TENSION

18 sts and 35 rows to 4"/10 cm in open pull-up st patt with TD7.

NOTE

Open pull-up st patt — every 6th N at NWP, 4 rows in pull-up st and 2 rows in St st.

BLANKET (2 pieces)

Using WY, cast on 76 sts. Knit a few rows, ending with carr on right. Push every 6th N into NWP. Change to TD7. RC000. Using MC, knit to RC350 in pull-up st patt. Waste knit. Steam lightly. Close all sts of cast on and last rows with a crochet. Join side seam. Steam lightly.

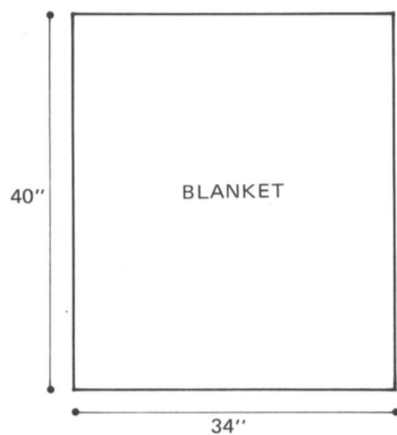

CAP, MITTENS AND SOCKS

MATERIALS

- * 1 [3 oz/85 g] ball of COATS & CLARK RED HEART "SOFSPUN pompadour yarn" in #1 White (MC)
- * Ribbon 72½"/184 cm
- * Elastic thread 10"/25 cm

GAUGE/TENSION

*21 sts and 27 rows 4"/10 cm in lace patt with TD4.

*22 sts and 34 rows to 4"/10 cm in St st with TD4.

CAP

Using WY, cast on 74 sts. Knit a few rows, ending with carr on right. Change to TD4. RC000. Using MC, knit to RC34 in lace patt. Bind off 24 sts at each side. Push empty Ns into NWP. Knit 6 rows. Dec 1 st at each end, every 6th row 4 times. Knit 6 rows. Bind off all sts.

FINISHING

With WS up, block and steam piece. Close sts of cast on row with crochet. Join marked positions. Make trimming (1), (2) with crochet. Put ribbon in place. Embroider at edge.

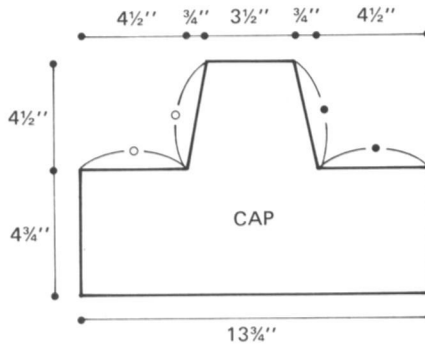

MITTENS

Using WY, cast on 26 sts. Knit a few rows, ending with carr on right. Change to TD4. RC000. Using MC, knit to RC38 in St st. Break MC, and thread all sts on Ns. Take off sts.

FINISHING

Steam lightly. Close sts of cast on row using crochet. Draw up last row. Join side seams. Make trimming along hem using 3 chain st and 1 slip st. Make 3 motifs with chain st and add them on each mitten. Put elastic thread in place.

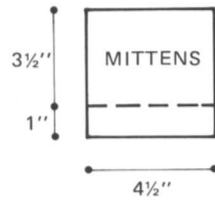

SOCKS

Using WY, cast on 44 sts. Knit a few rows, ending with carr on right. Change to TD4. RC000. Using MC, knit to RC18 (A). Waste knit. Hang center 12 sts of last row of (A) onto Ns and knit 18 rows (B). Waste knit. Using WY, Cast on 28 sts. Knit a few rows, ending with carr on right. Using MC, knit 18 rows TD4 (C). Bind off all sts loosely.

FINISHING

Steam lightly. Graft 12 sts of (B) last row and center 12 sts of (C) cast on row. Join side seams as shown by marks. Make trimming (1) with crochet. Embroider at instep. Put ribbon in place.

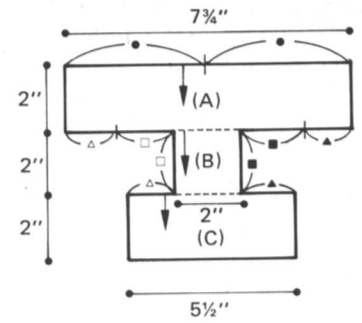

PULL-UP STITCH PATTERN

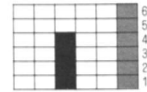

■ Needle in HP
■ Needle in NWP

LACE PATTERN

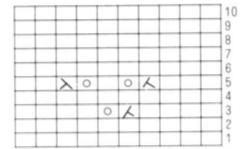

HOW TO MAKE TRIMMING

(1)

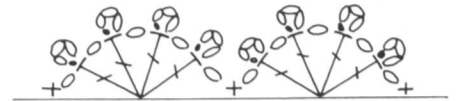

(2)

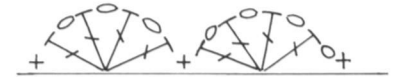

HOW TO MAKE A MOTIF

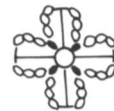

○ Chain st
● Slip st
⊥ Double crochet

EMBROIDERY



Wind MC around tapestry needle. Pull it through MC.



7



8



9



10

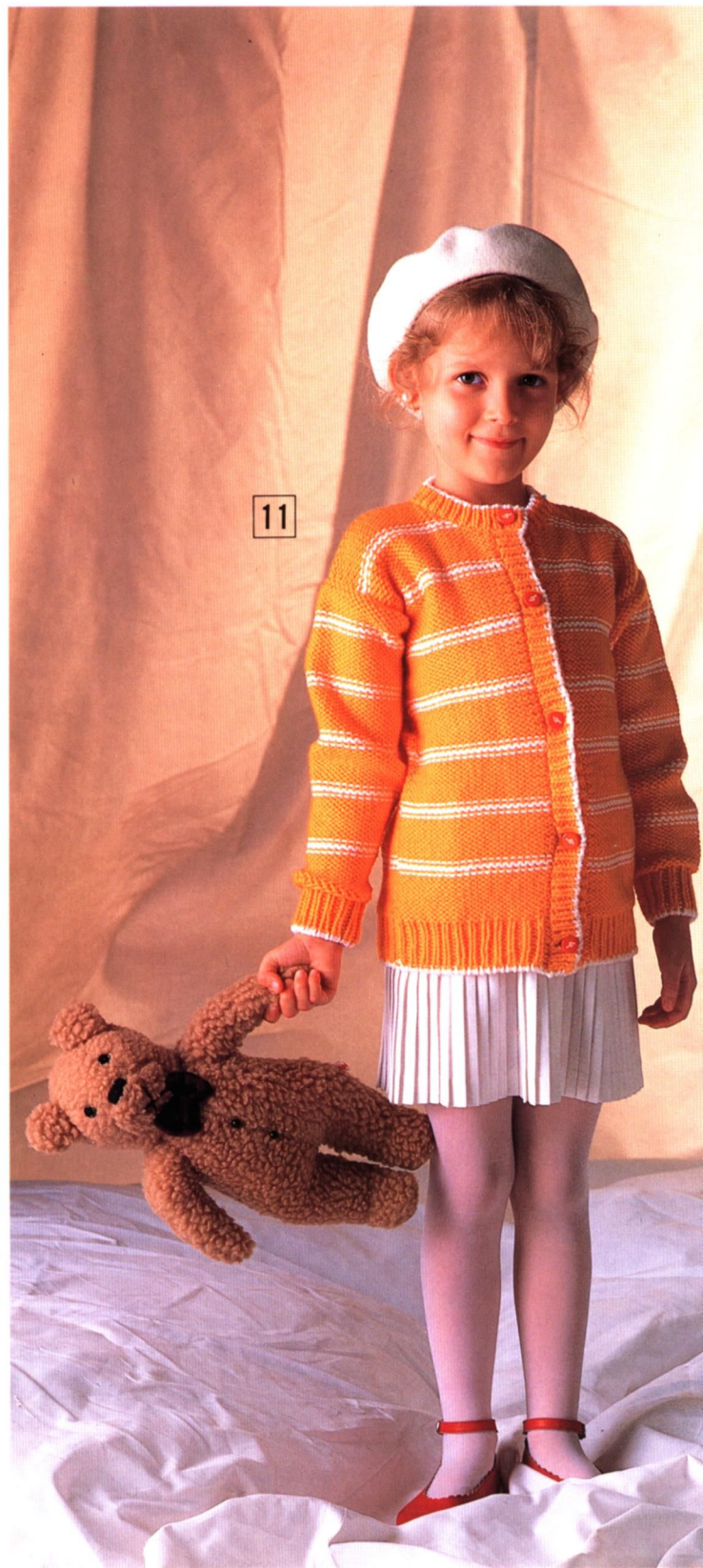

11



12

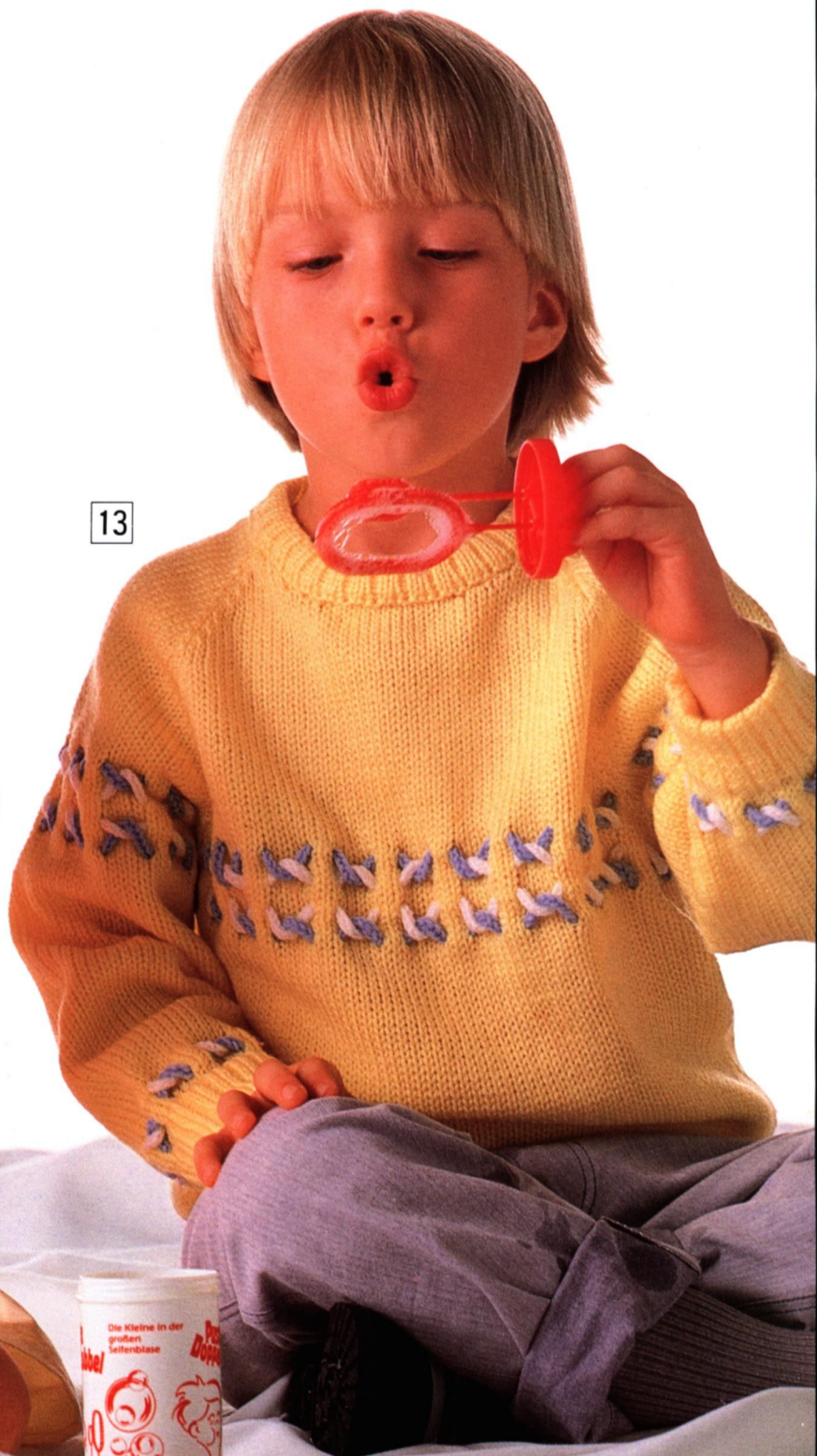

13



