

SERVICE MANUAL

DOUBLE KNITTING GAUGE MACHINE SK160

SILVER REED

C O N T E N T S

[1] MAIN COMPONENTS AND PARTS OF THE MACHINE	1
1-1 Machine Body	1
1-2 Carriage (Inside)	2
1-3 Carriage (Underside)	3
1-4 Arm	4
[2] CARRIAGE DISASSEMBLY AND ASSEMBLY	5
2-1 Carriage Disassembly	5
2-2 Carriage Assembly	7
[3] MACHINE BODY DISASSEMBLY AND ASSEMBLY	9
3-1 Disassembly of Machine Body	9
3-2 Assembly of Machine Body	10
[4] ADJUSTMENT OF EACH PART OF THE MACHINE	11
4-1 Rail-to- Sinker Dimension	11
4-2 Main Cam Adjustment	14
4-3 PN Adjustment	15
4-4 PS Adjustment	19
4-5 YS Adjustment	21
4-6 Brush Holder Adjustment (up-down positioning)	22

[1] MAIN COMPONENTS AND PARTS OF THE MACHINE

1-1 Machine Body

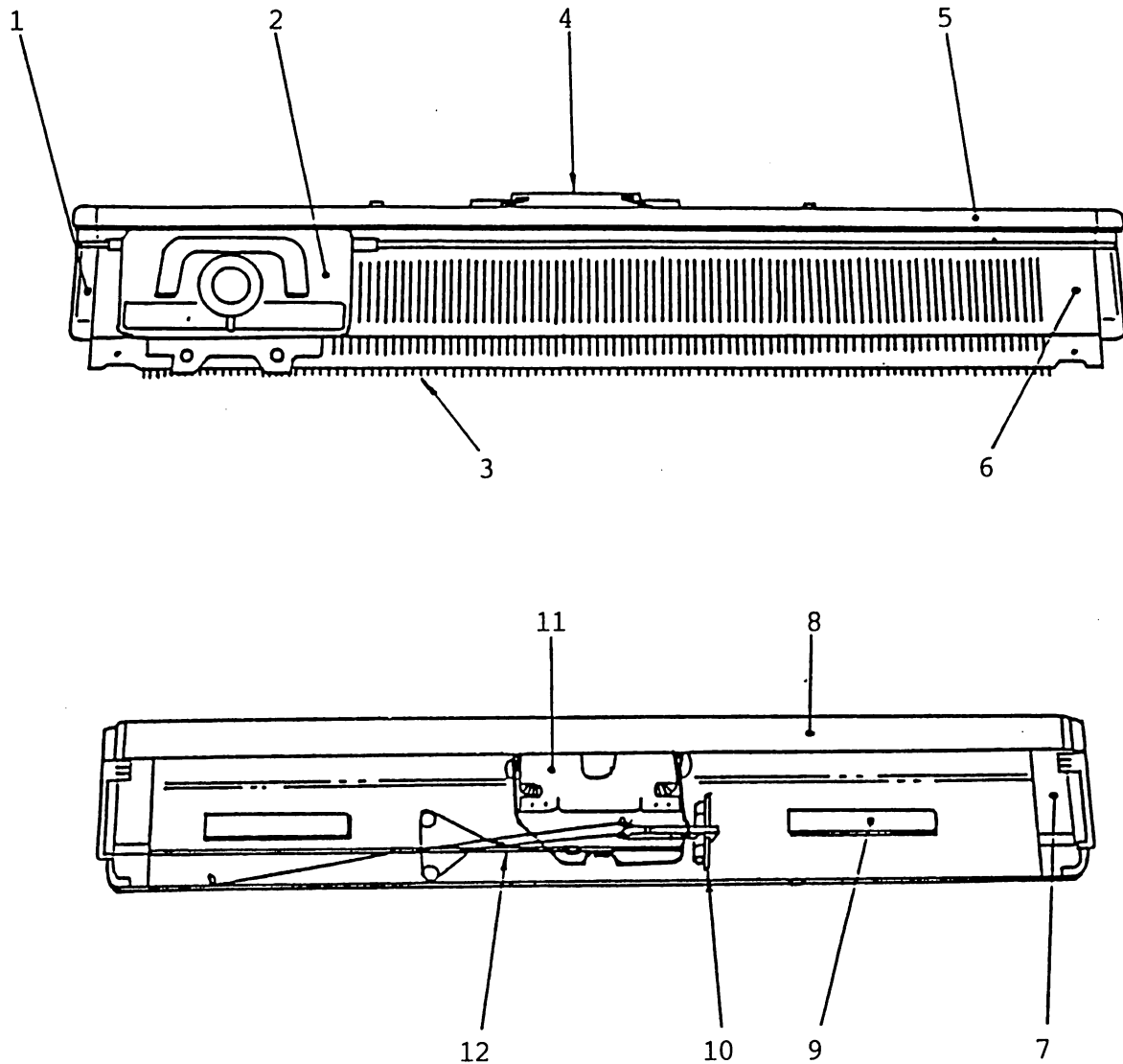

Fig.1

- 1. Side Cover for Case (L)
- 2. Carriage
- 3. Sinker
- 4. Carrying Handle
- 5. Case
- 6. Needle Bed

- 7. Side Cover for Top Cover (R)
- 8. Top Cover Unit
- 9. A.B. Protector
- 10. Tension Unit
- 11. Arm Unit
- 12. Yarn Rod Unit

1-2 Carriage (Inside)

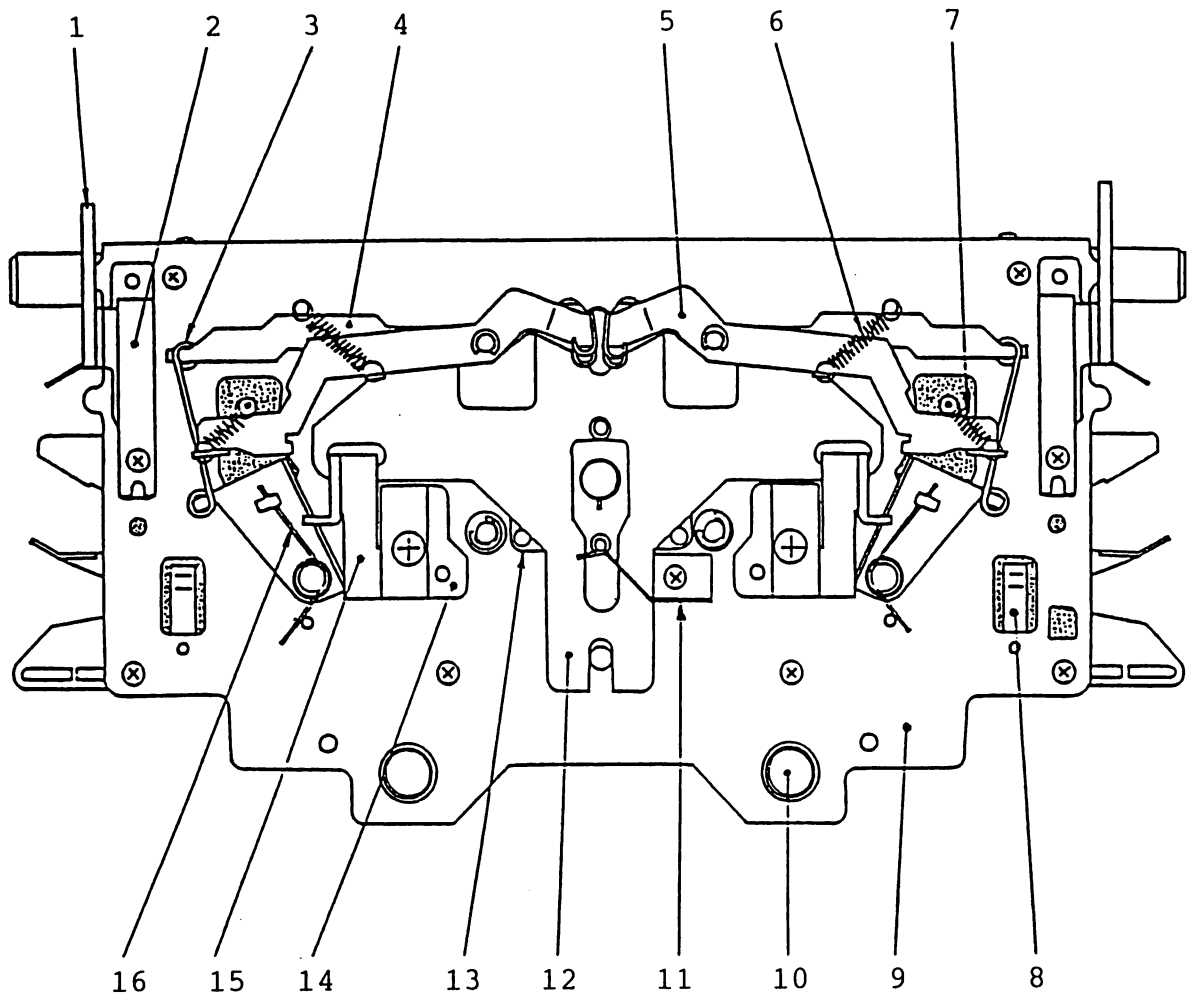

Fig.2

- | | |
|------------------------|------------------------------|
| 1. RC Lever | 9. Carriage Plate |
| 2. RC Lever Spring | 10. Arm Nut |
| 3. AG Lever B | 11. Dial Spring |
| 4. AG Lever A (L) | 12. Travelling Plate |
| 5. Sub Lever (R) | 13. Moving Plate |
| 6. Sub Lever Spring | 14. Handle Holder (L) |
| 7. Sub Cam Spring | 15. Handle Holder Spring (L) |
| 8. Russel Lever Spring | 16. AG Lever Spring (L) |

1-3 Carriage (Underside)

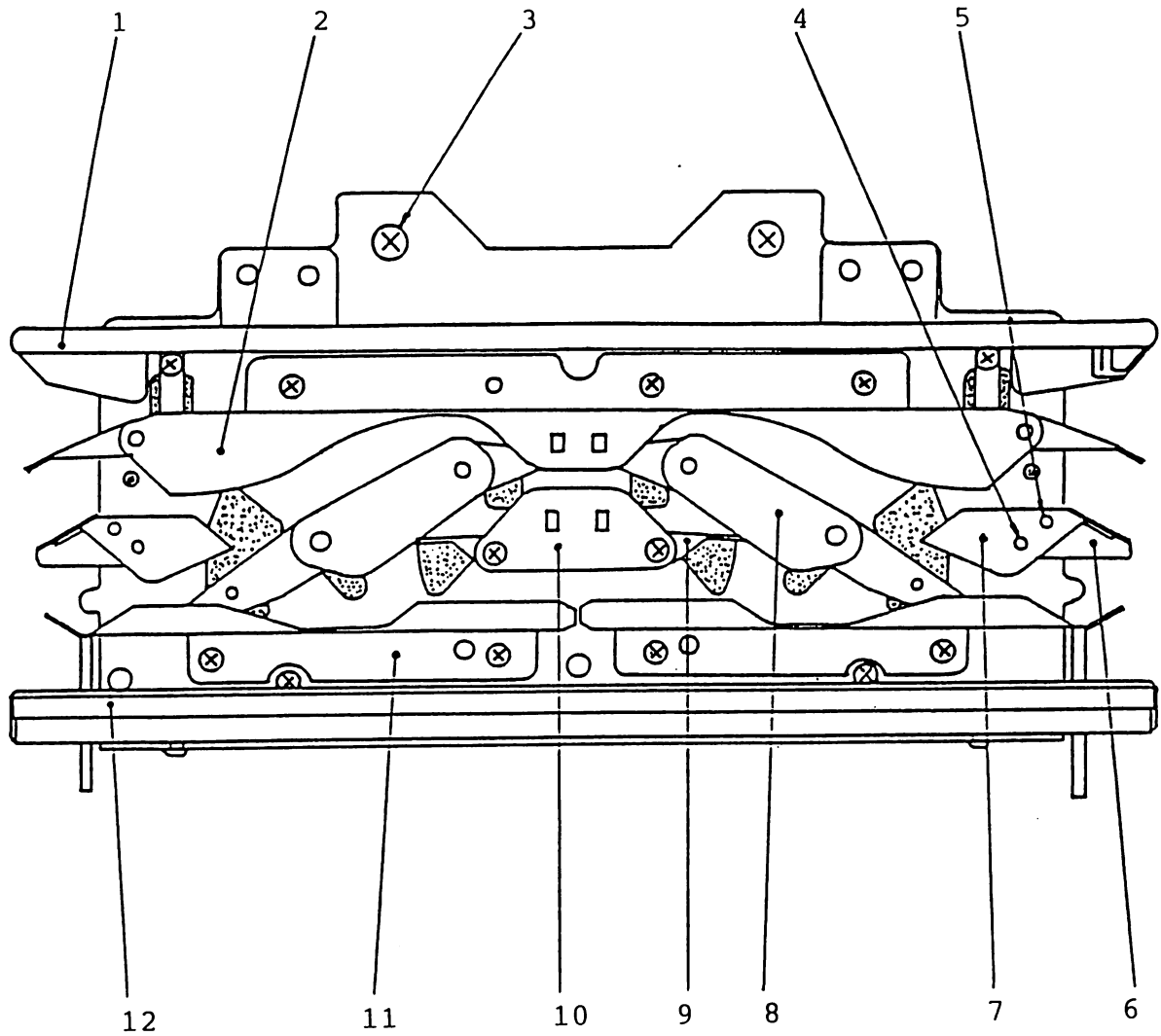

Fig.3

- | | |
|----------------------------|----------------------|
| 1. Slider | 7. Guard Cam A (R) |
| 2. Needle Guide Unit | 8. Main Cam Unit (R) |
| 3. Binding Head Screw 5x18 | 9. Tuck Cam (R) |
| 4. Guard Cam Rivet B | 10. Tuck Cam Base |
| 5. Guard Cam Rivet A | 11. Guide Plate (L) |
| 6. Guard Cam B (R) | 12. Carriage Pipe |

1-4 Arm

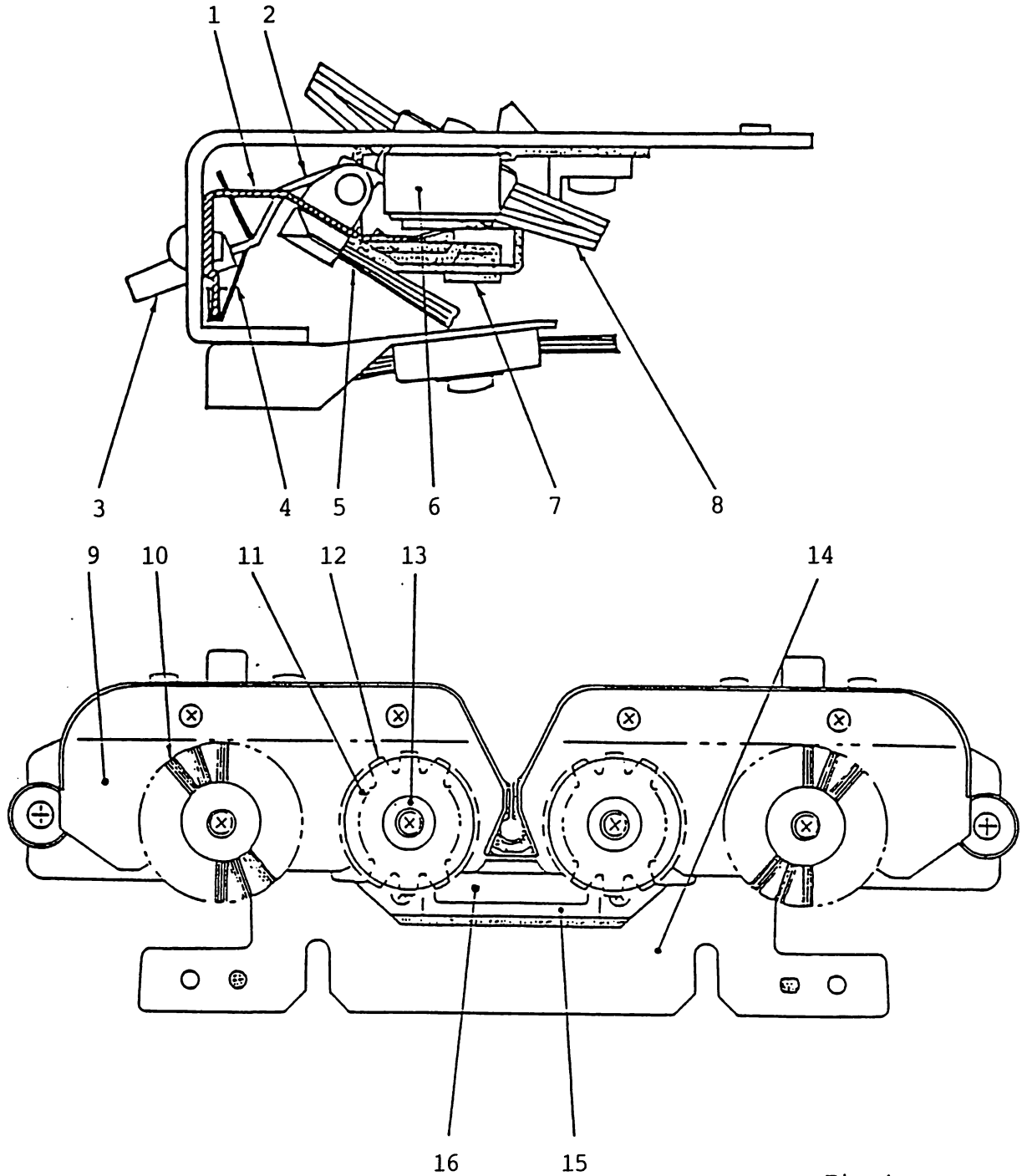

Fig.4

- | | |
|-------------------------|------------------------|
| 1. Brush Holder (R·L) | 9. Fabric Presser (L) |
| 2. Weaving Brush Base | 10. Round Brush C |
| 3. Weaving Brush Knob | 11. Brush Cover |
| 4. Weaving Brush Spring | 12. Rubber Gear |
| 5. Clearing Brush | 13. Rubber Gear Collar |
| 6. Latch Magnet D | 14. Arm |
| 7. Yarn Feeder | 15. Latch Magnet Cover |
| 8. Tuck Brush | 16. Latch Magnet B |

[2] CARRIAGE DISASSEMBLY AND ASSEMBLY

2-1 Carriage Disassembly (Up to Carriage Cover)

1. Turn over the Carriage, as shown in Fig.5, and loosen two Binding Head Tapping Screws (3x10).

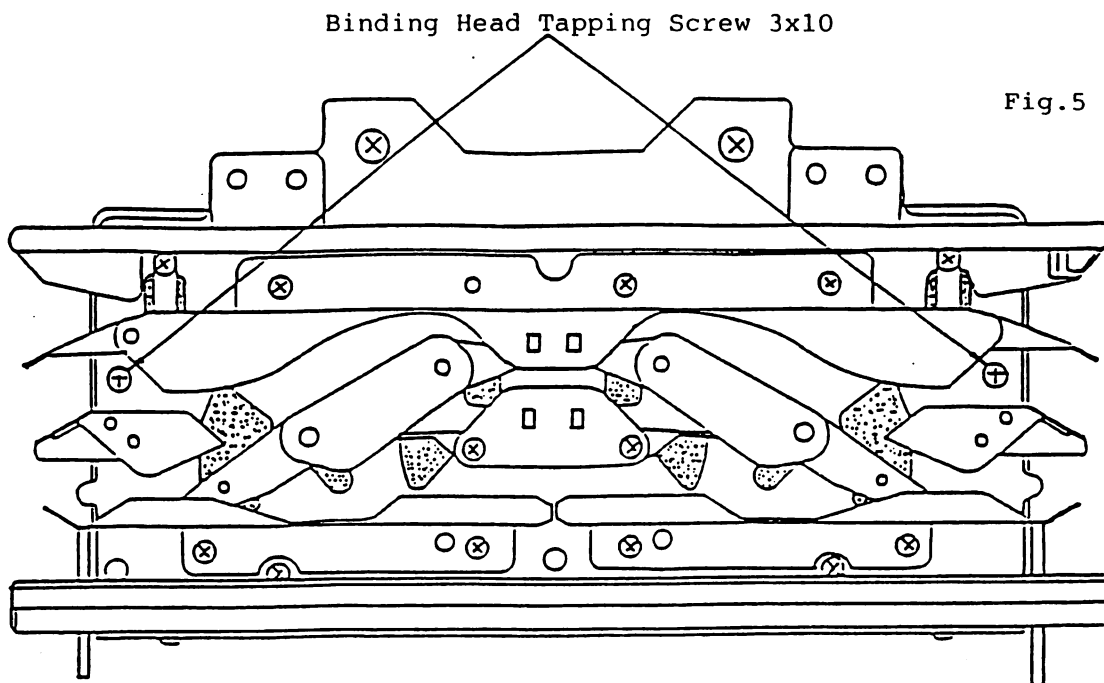

2. Fold the Carriage Handle backwards as indicated in Fig.6.
3. Remove the two Carriage Handle Screws, both of which located in a recess at the foot of both sides of the Carriage Handle, by using +Screwdriver.

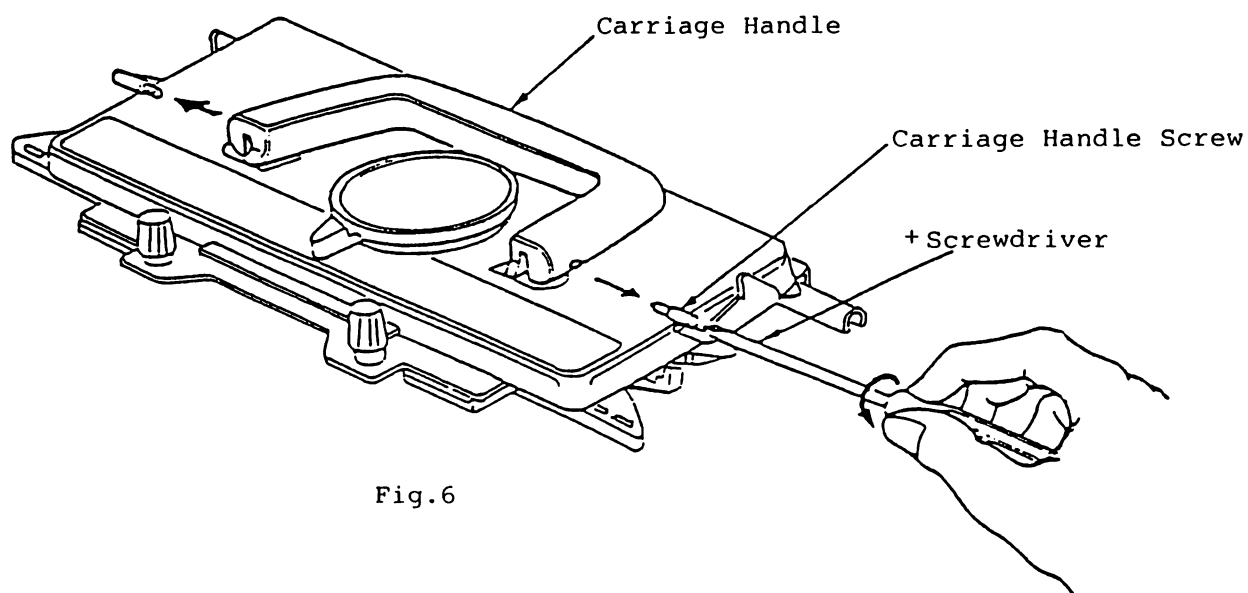

4. Turn the Stitch Dial fully in a clockwise direction, and remove it by lifting.

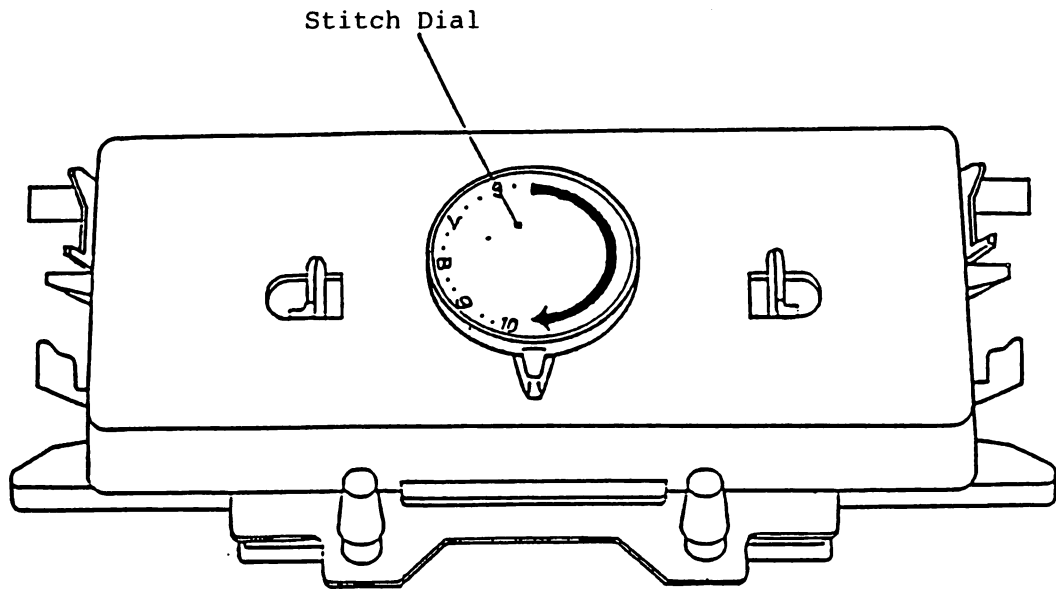

Fig.7

5. Set the Cam Lever to "FAIR ISLE". While pushing out the Dial Spring with the tip of a Screwdriver, pull out the Cam Lever together with the Carriage Cover as shown in Fig.8.

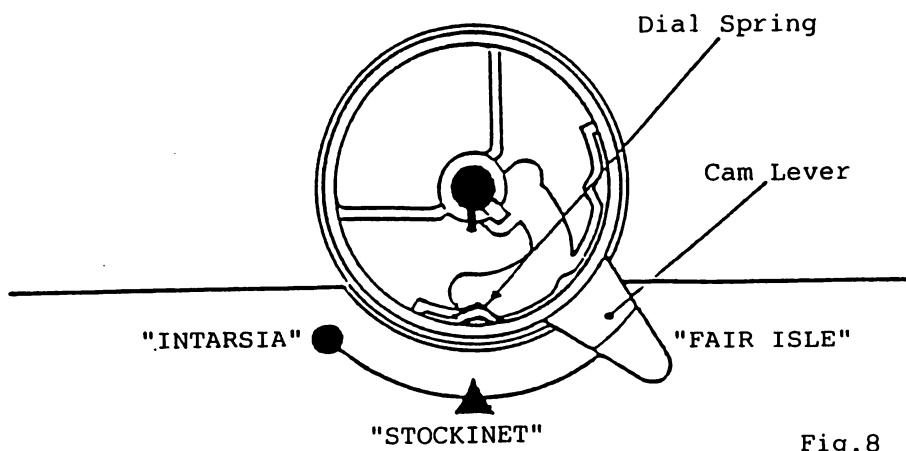

Fig.8

2-2 Carriage Assembly

1. Place the Cam Lever through the Carriage Cover by pushing it in the arrowed direction, and secure it in the Dial Aubour.

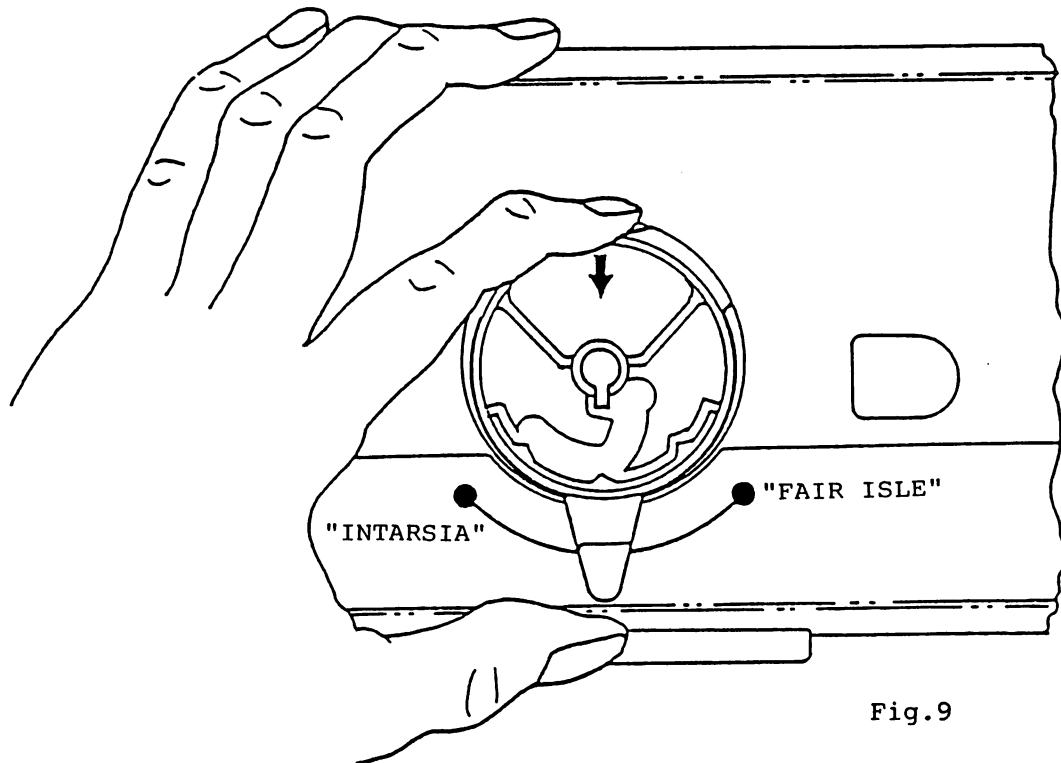
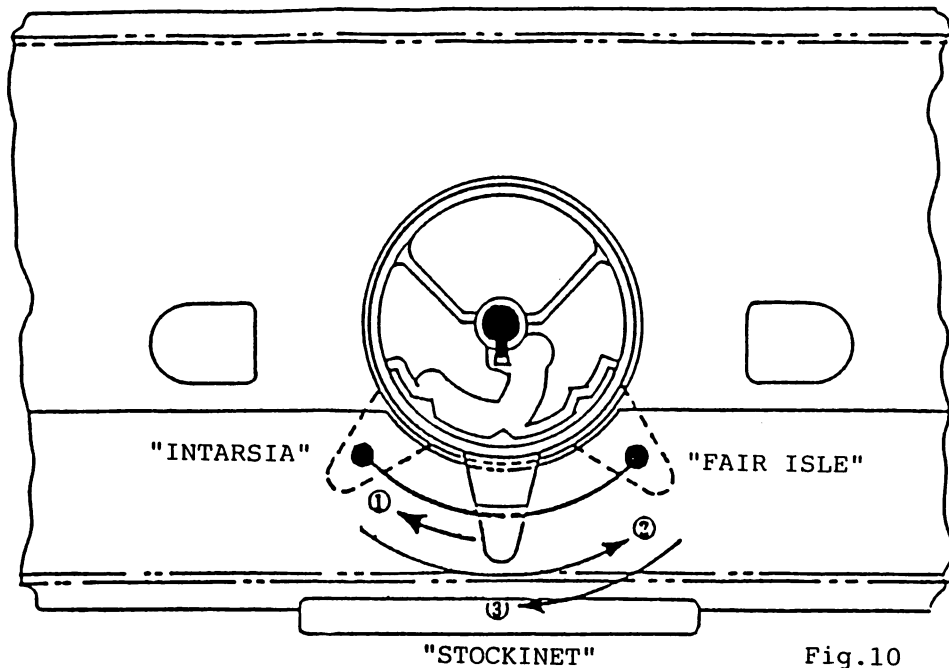
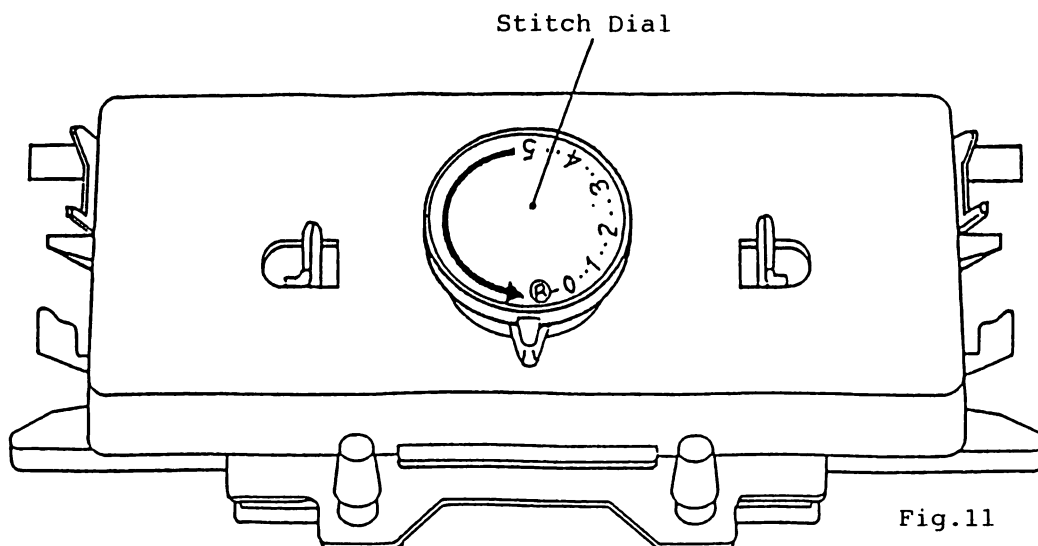

Fig.9

2. Turn the Cam Lever towards "INTARSIA"(1) while pushing it down, and the Cam Lever will be fallen down.
At this point, turn it to "FAIR ISLE"(2) while pushing it down, and it becomes engaged with in the position immediately.
Then position the Cam Lever at "STOCKINET"(3).



3. Place the Stitch Dial onto Dial Shaft, and turn the Dial in the arrowed direction, while pushing it down as shown in Fig.11, until it fits in the position.



4. With the Carriage Handle down as shown in Fig.12, secure it by fastening the two Screws.

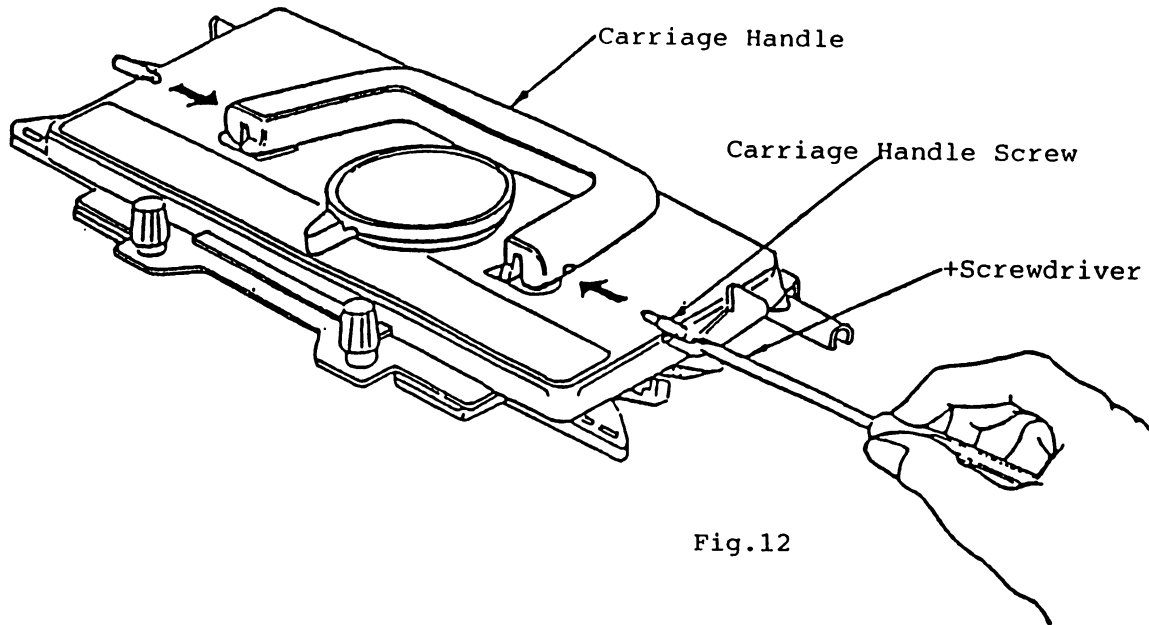

Fig.12

[3] MACHINE BODY DISASSEMBLY AND ASSEMBLY

3-1 Disassembly of Machine Body

1. Place the Machine Body upside down as shown in Fig.13, remove the Binding Head STT Screw (3x6) located between Rubber Pads.
2. Unlock the Latch Locks, and remove two Oval Head Countersunk Screws (2.6x4.5) securing the Latch Locks.

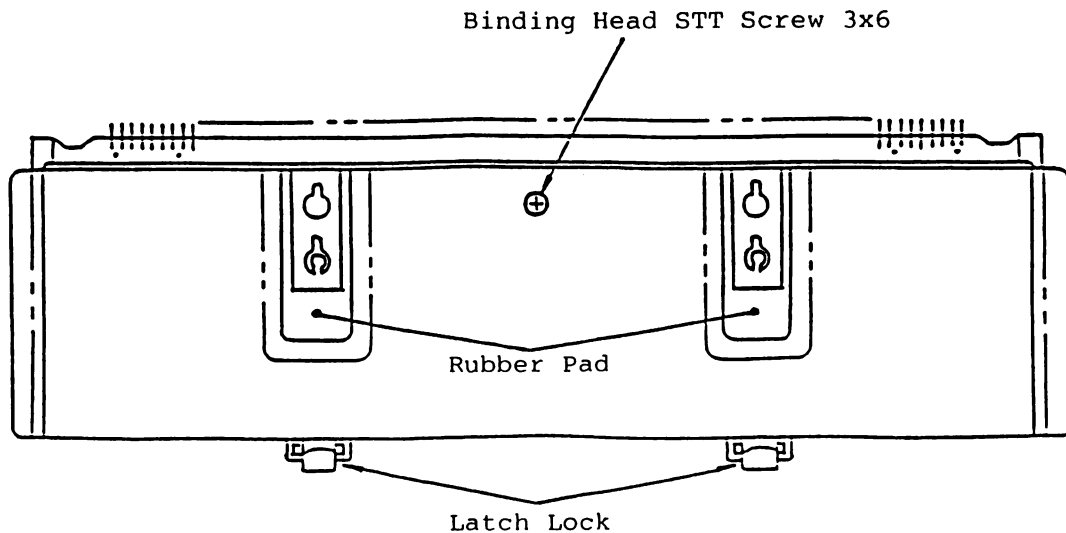
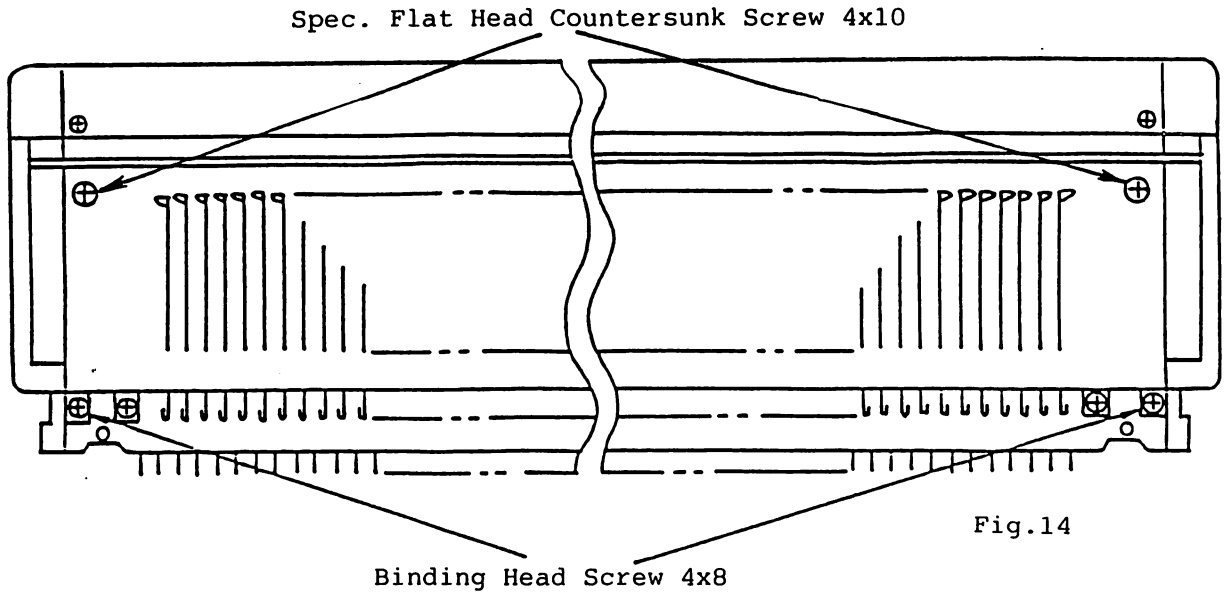

Fig.13

- Turn over the Machine Body to the top. Remove two Binding Head Screws (4x8) securing the front edges of Needle Bed and two Spec. Flat Head Countersunk Screws (4x10) securing the Needle Bed. Then slightly lift the front edge of Needle Bed and draw it out from the Case.



3-2 Assembly of Main Body

*REVERSE THE PROCEDURE OF THAT USED FOR THE DISASSEMBLY OF MACHINE BODY.

(Note) Make sure to secure the Latch Locks in the arrowed direction as shown in Fig.15.

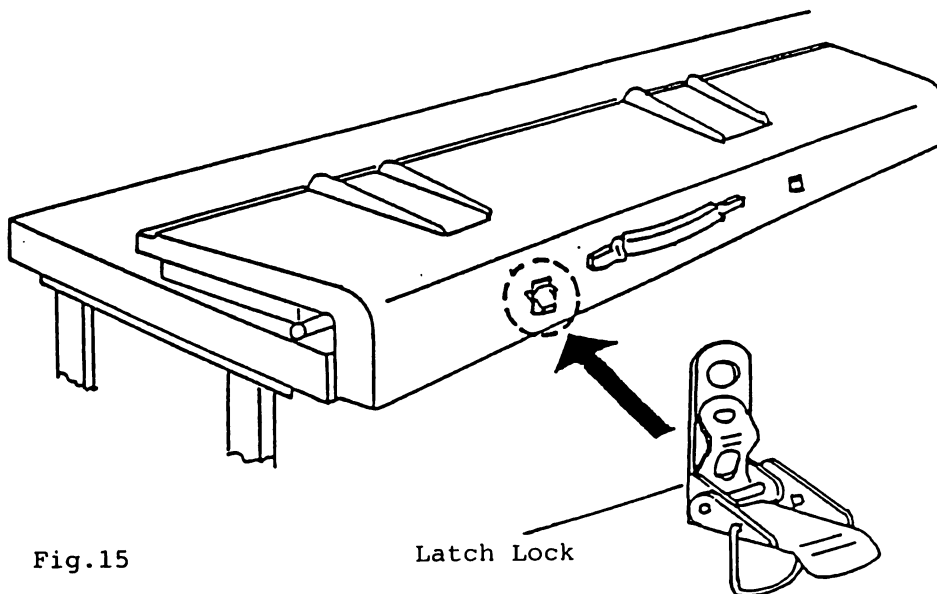

4. ADJUSTMENT OF EACH PART OF THE MACHINE

4-1 Adjustment of Rail-to-Sinker Dimension (Needle Bed)

1. If the maximum distance between the Rail and Sinkers differs by more than 0.3mm from the minimum distance, the size of stitches will be uneven.

* The dimension from the rear surface of Carriage Rail to tips of Sinkers must be $149.35\text{mm}\pm 0.25$. (The range of deviation between the maximum and minimum measurements must be within 0.3mm.)

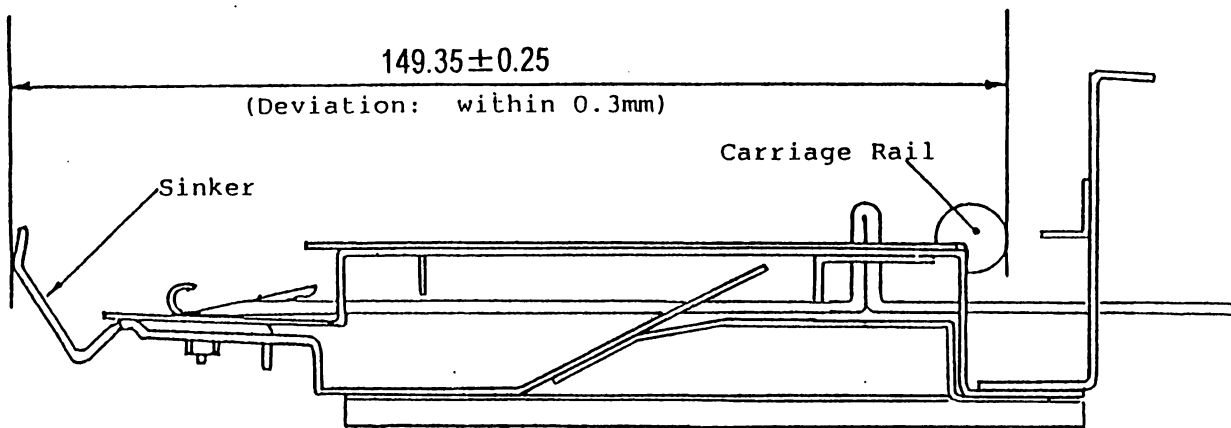

Fig.16

2. Draw the Needle Bed out from the case and measure the dimension between the Rail and Sinkers at needle positions of both 50,25 and 0.

3. Adjusting Method

Loosen slightly four Hexagonal Nuts 2, 3 securing the Sinker Plate where the dimension has to be adjusted.

[For Rail-to-Sinker Dimension as an example]

- a. In case it is necessary to adjust the portion of Sinkers to be adjusted A, loosely secure four Hexagonal Nuts 2, 3 in a range of A.
- b. In case it is necessary to adjust the portion of Sinkers to be adjusted B, loosely secure four Hexagonal Nuts 2, 3 in a range of B.
In this case, also loosen two Binding Head Screws (3x6) securing Needle Bed Bracer B.

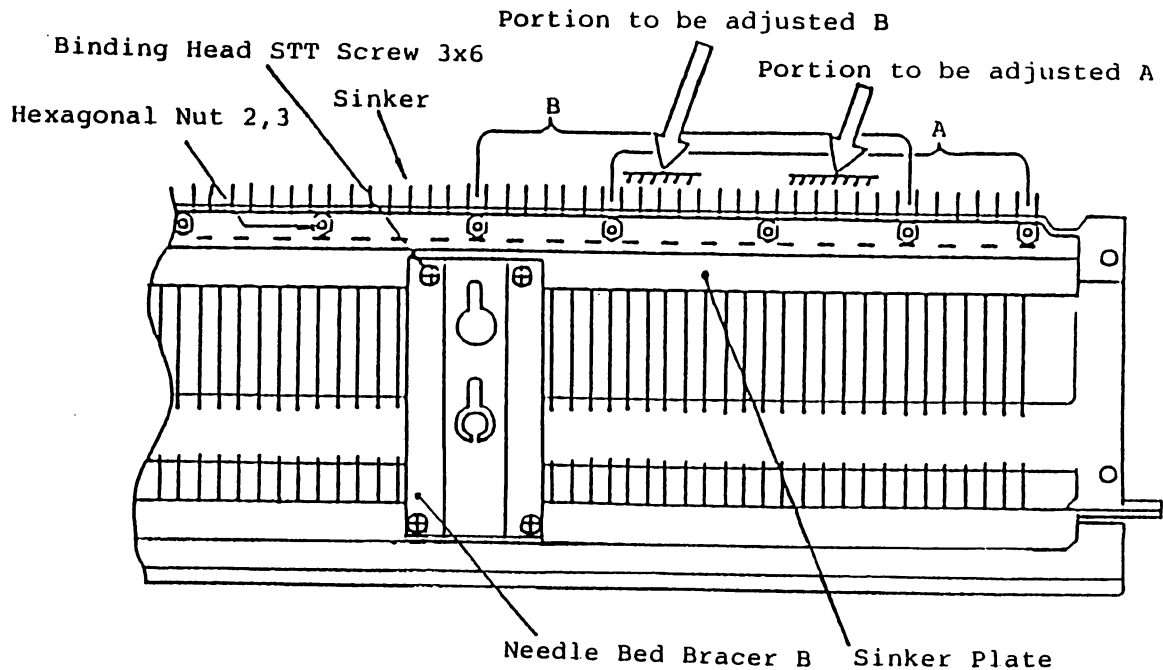

Fig.17

4. In case it is necessary to move the Sinkers forwards:

- a. Loosely secure four Hexagonal Nuts previously loosened.
- b. Move forwards the portion of Sinkers to be adjusted by tapping the Sinker Plate with a Hammer as shown in Fig.18 and 19.
- c. Measure the dimension after tightening four Hexagonal Nuts.

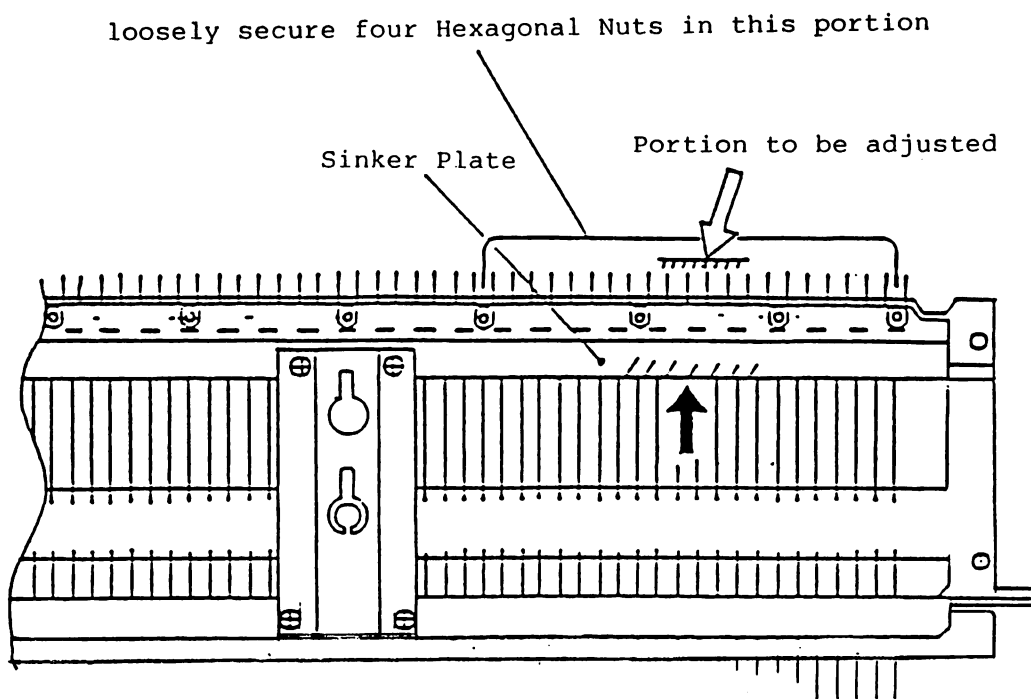

Fig.18

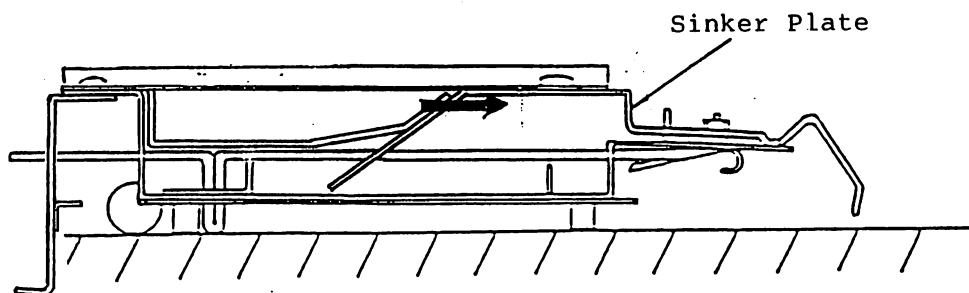

Fig.19

5. In case it is necessary to move the Sinkers backwards:

- a. Loosely secure four Hexagonal Nuts previously loosened.
- b. Press the foot of the Sinker Post with the rounded part of a Wooden Hammer as shown in Fig.20.
- c. Measure the dimension after tightening four Hexagonal Nuts.

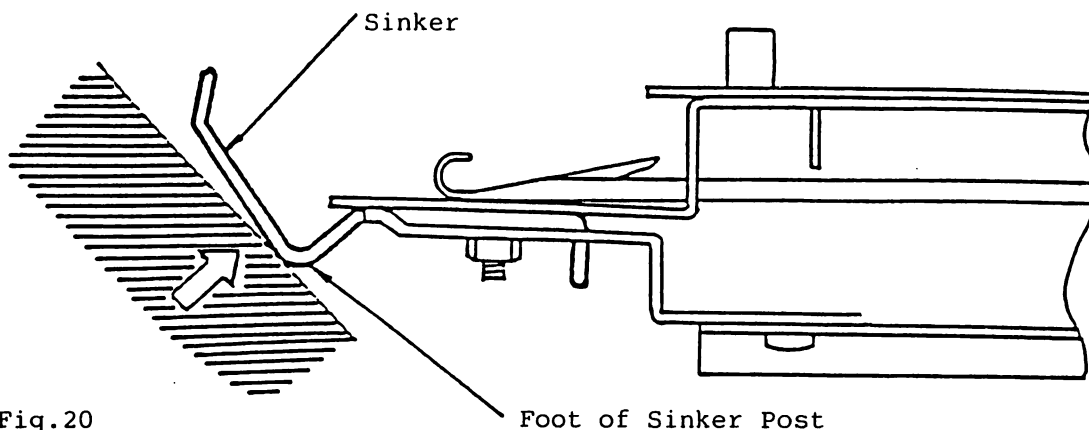

Fig.20

4-2 Adjustment of the Dimension from Carriage Pipe (front surface) to Main Cam Unit 21mm±0.2

Adjusting Method

Remove the Binding Head Screw (3x4) and loosen the Binding Head Screw (3x7), then insert a Plain Washer (3.1x6x0.2) between the Carriage Plate and Carriage Pipe. Use a vernier caliper to measure the above specified dimension, while eliminating the play of Main Cam Unit by pushing it in the arrowed direction.

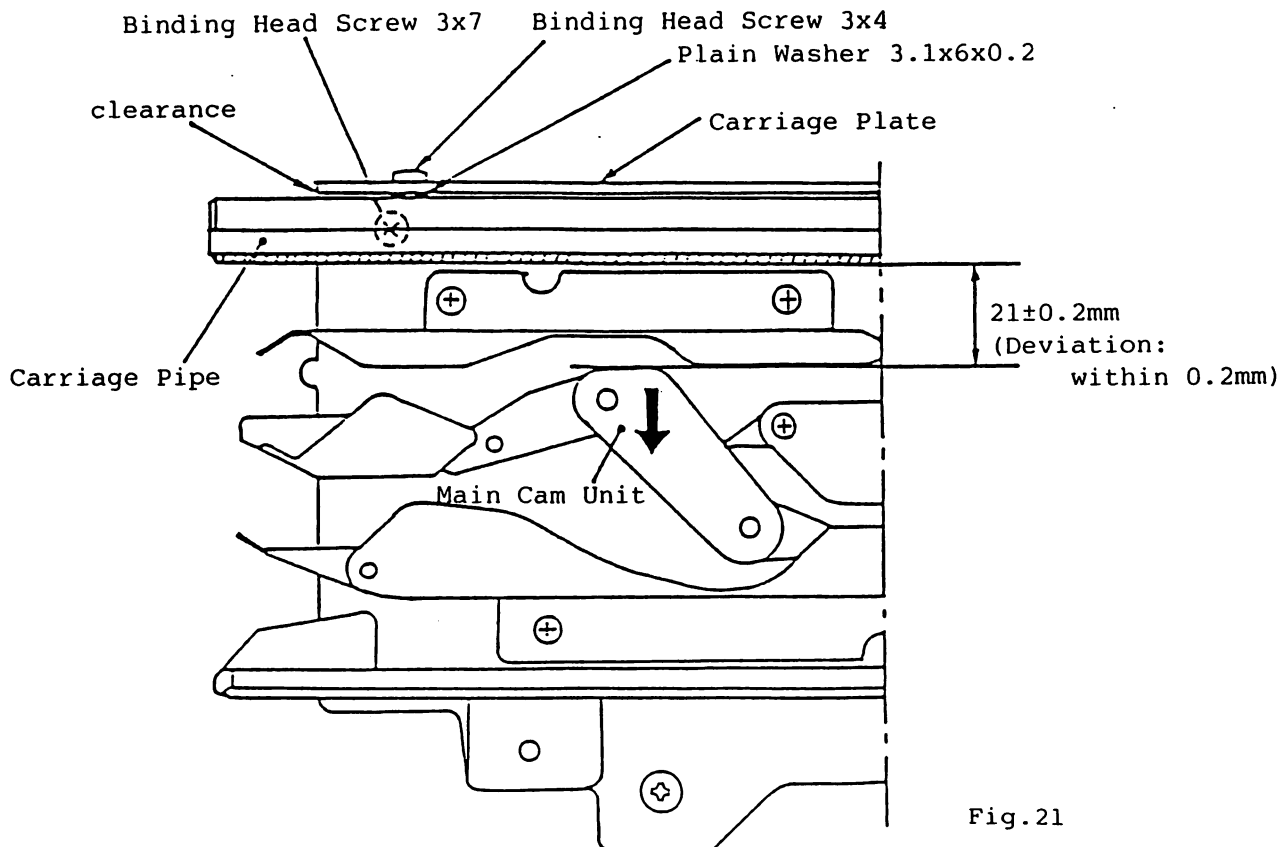
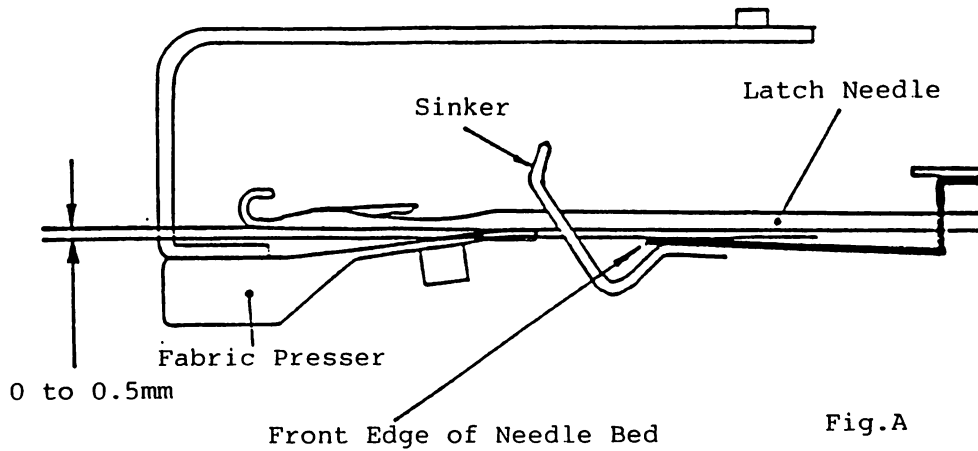

Fig.21

4-3 PN Adjustment (Adjusting the Angle of Fabric Presser)

1. PN Dimension..... 0 to 0.5mm

(The clearance between the bottom of Latch Needles and the front edge of Needle Bed -- the dimension to check the amount of contact between Fabric Presser and Latch Needles)



* In case the bottom of Latch Needles are in touch with the edge of Fabric Pressers and the front edge of Needle Bed as shown in Fig.B, the PN Dimension is 0mm.

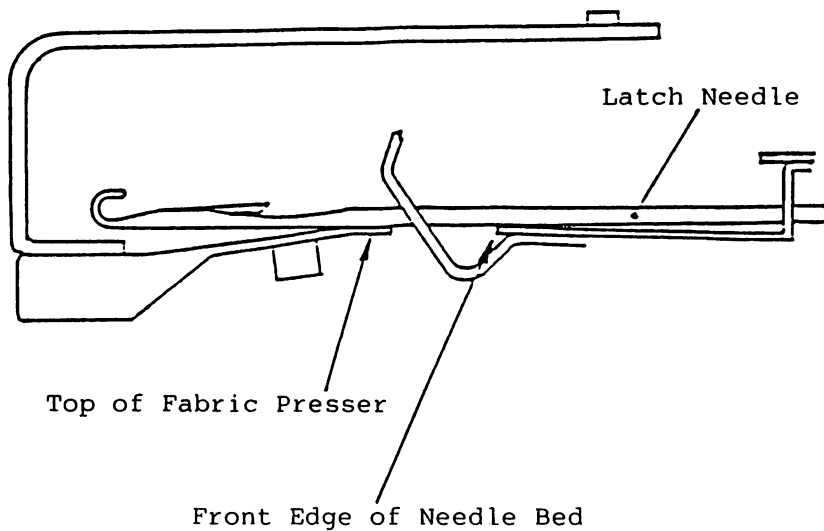

2. Measuring Method

- a. Push approximately 20 needles around the center of Needle Bed to D position, and set both Russel Levers to "I" position.
- b. Move the Carriage so that the needles are placed on the straight edge of Fabric Presser (Fig.A), and check the clearance between the bottom of Latch Needles and the front edge of Needle Bed using a feeler gauge (Fig.B).
- c. If the front edge of the Needle Bed touches the needles, refer to the next page for relevant adjustment.

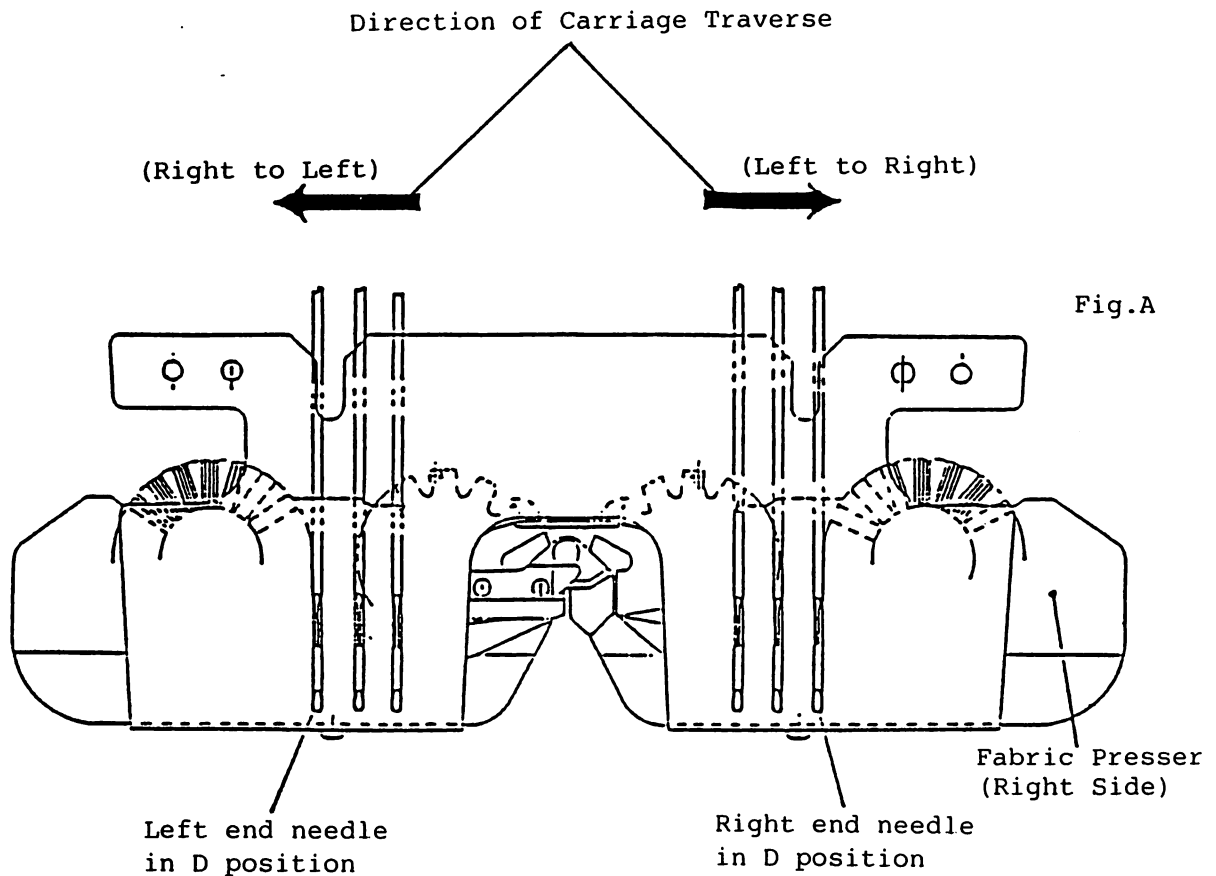
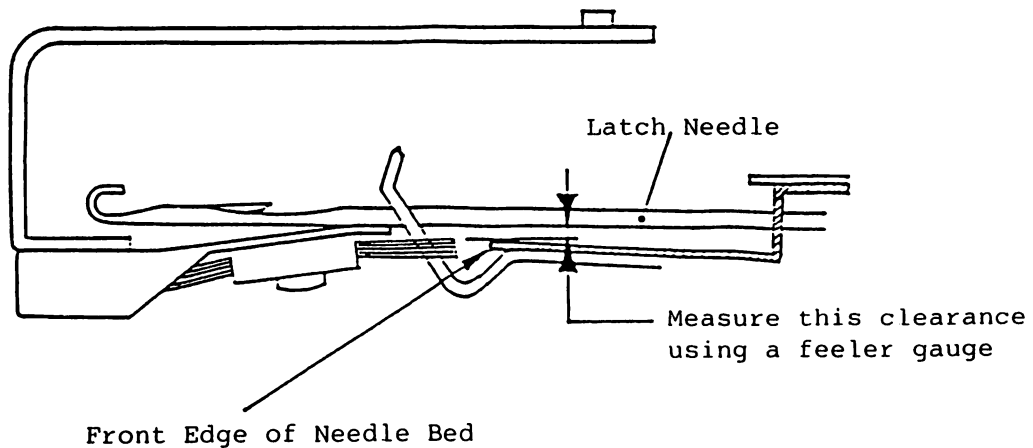

Fig.B



3. Adjusting Method

If there is a clearance between the edge of the Fabric Presser and needles as shown in Fig.A, remove the Arm from the Carriage, place it upside down, and depress Fabric Presser gradually by hand to adjust its angle adequately (Fig. B).

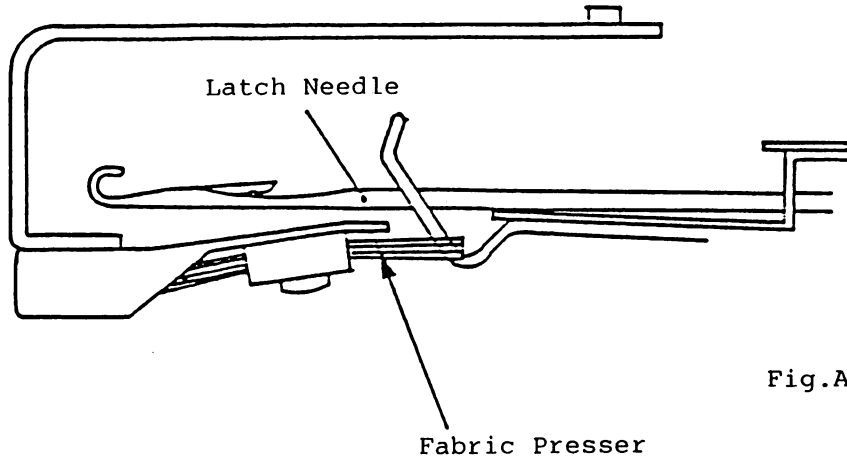

Fig.A

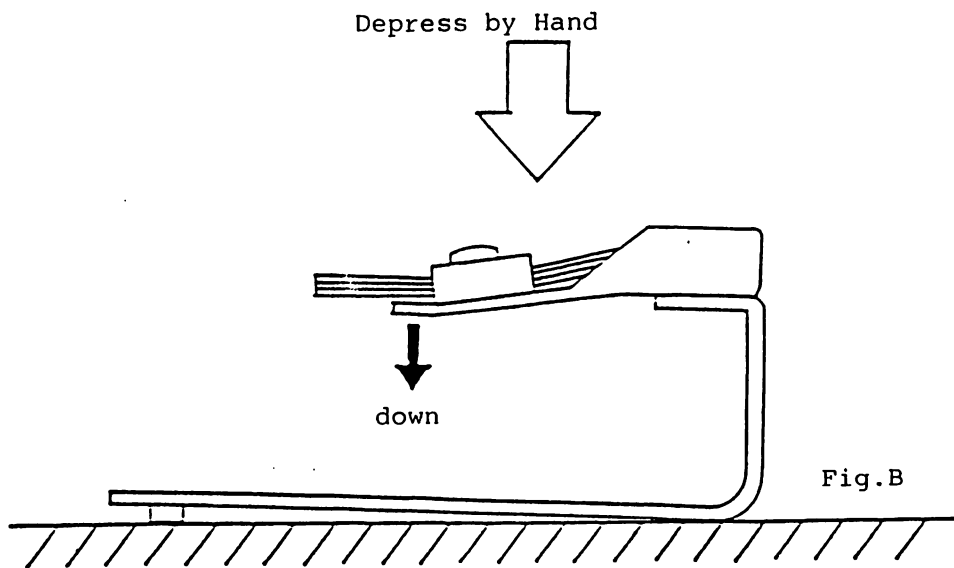
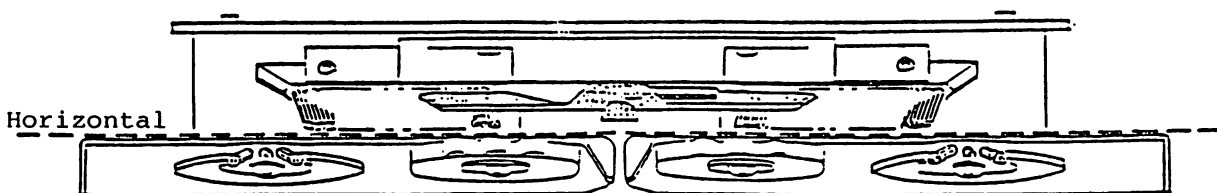

Fig.B

*Align both right and left Fabric Pressers horizontally.



4. Adjusting Method

If the clearance between front edge of the Needle Bed and the Latch Needles is more than 0.5mm (Fig.A), refer to the following procedure to adjust it angle.

- a. Place your thumbs on the Fabric Presser, and hold it with your hands firmly (Fig.B).
- b. Depress the Fabric Presser downward gradually.

(Note) Do not apply too much force to the Fabric Presser when depressing it.

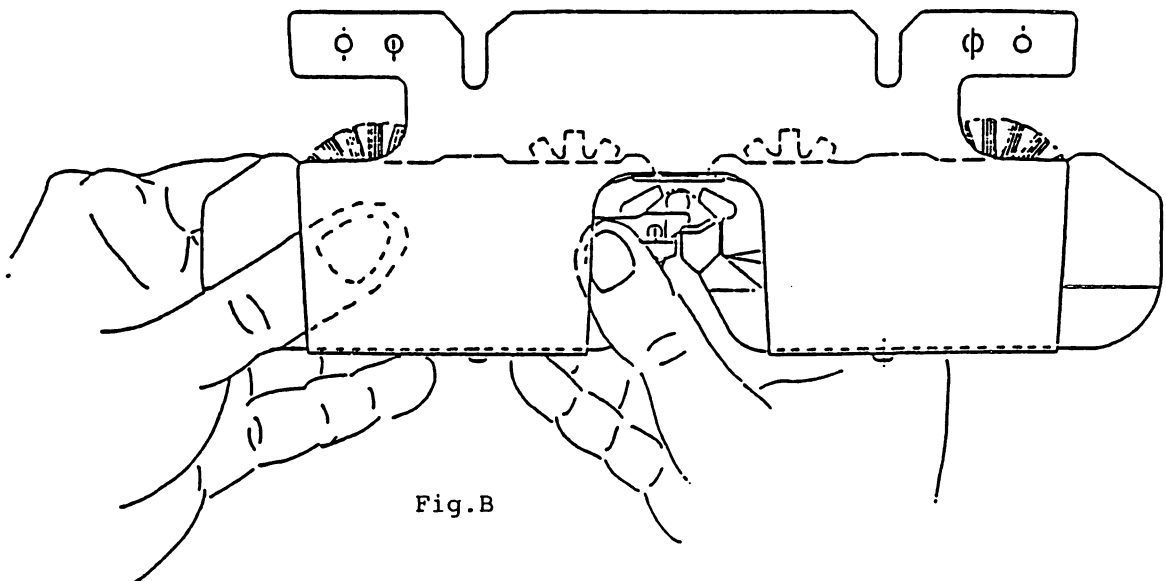
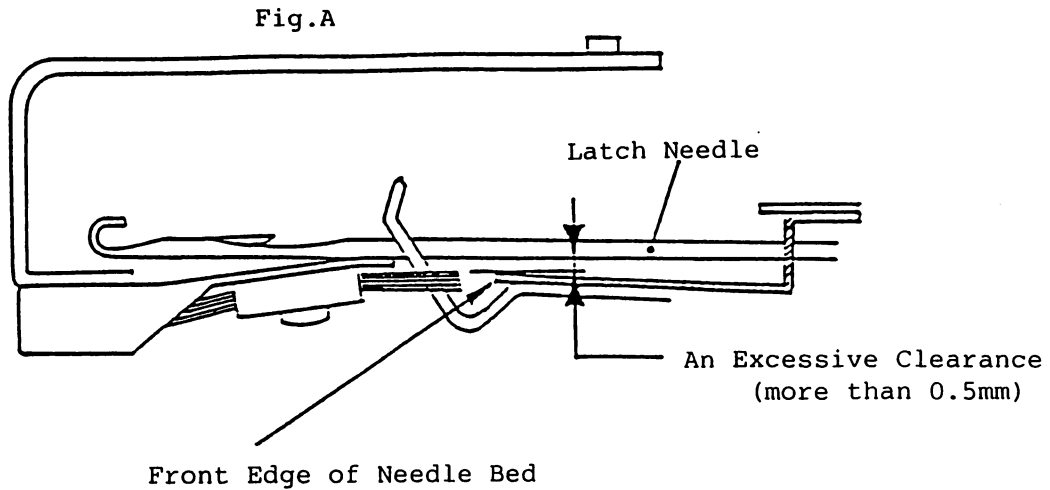

4-4 PS Adjustment (Adjusting the Clearance between Fabric Presser and Sinkers)

1. PS Dimention..... 0.5 to 1.5mm

(The clearance between the edge of Fabric Presser and Sinkers)

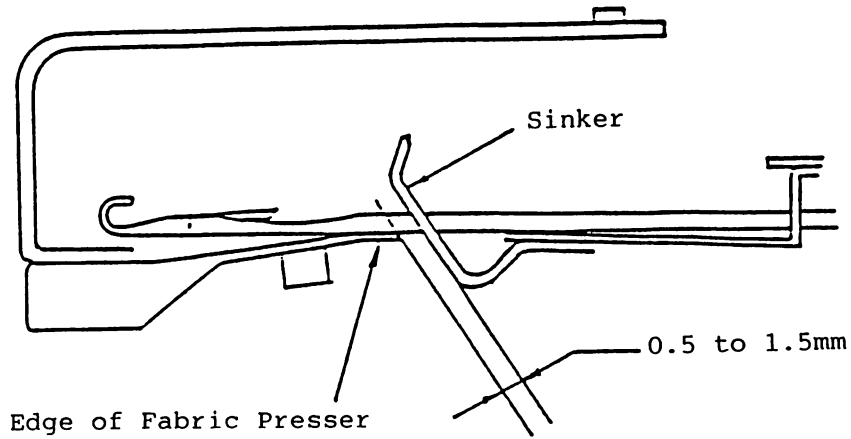

Fig.22

2. Adjusting Method

- a. Before attempting the adjustment, remove the Round Brush C and Rubber Gear to facilitate the adjustment. Loosen four Binding Head Screws (3x3.5) securing Fabric Presser. Slide the Fabric Presser fully in the arrowed direction (white), and loosely secure the presser with the screws. (Secure the screws to the extent that you can adjust the Fabric Pressers by tapping them slightly with a handle of screwdriver.)

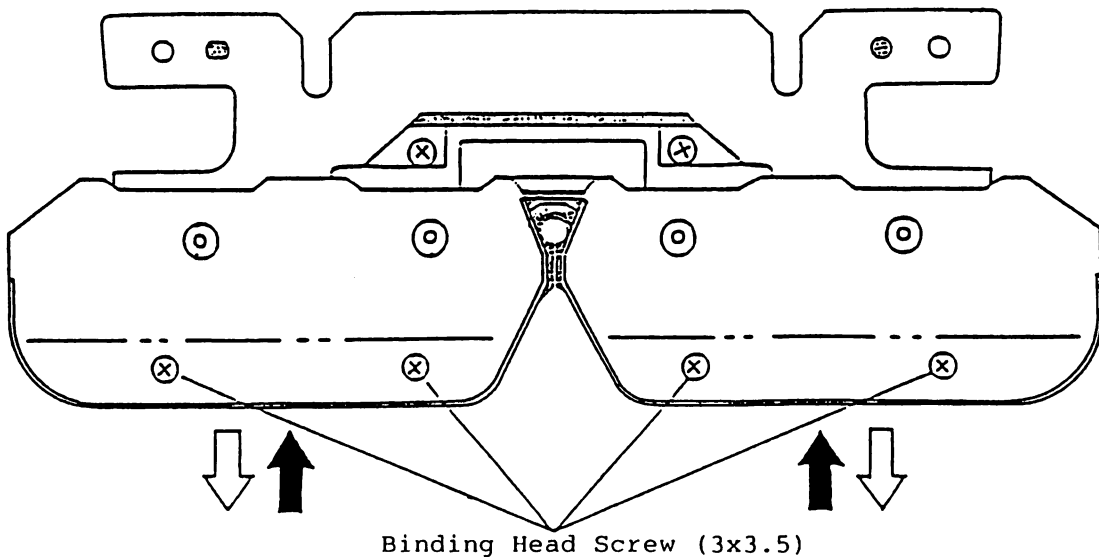
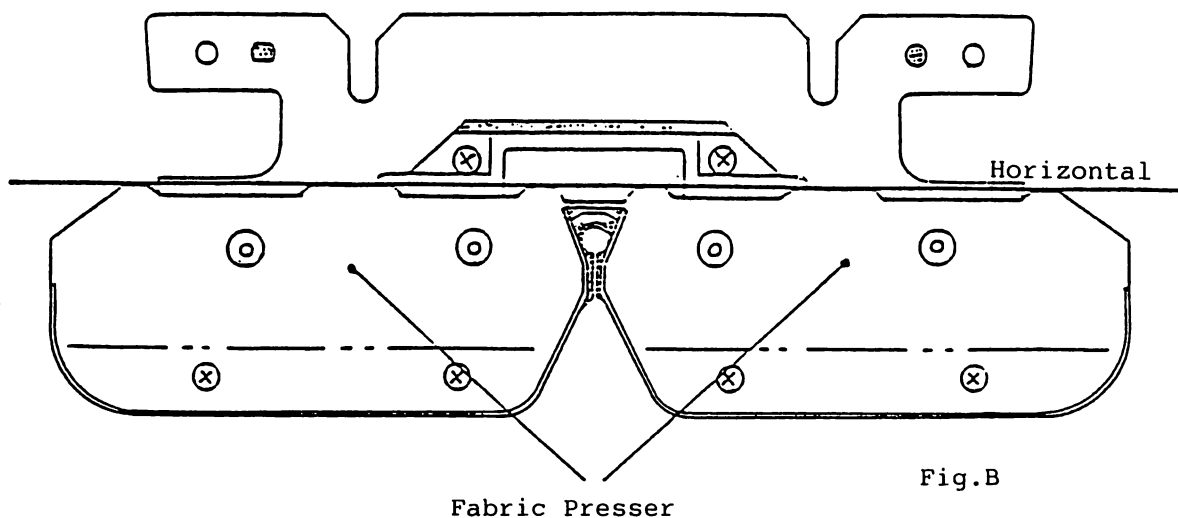
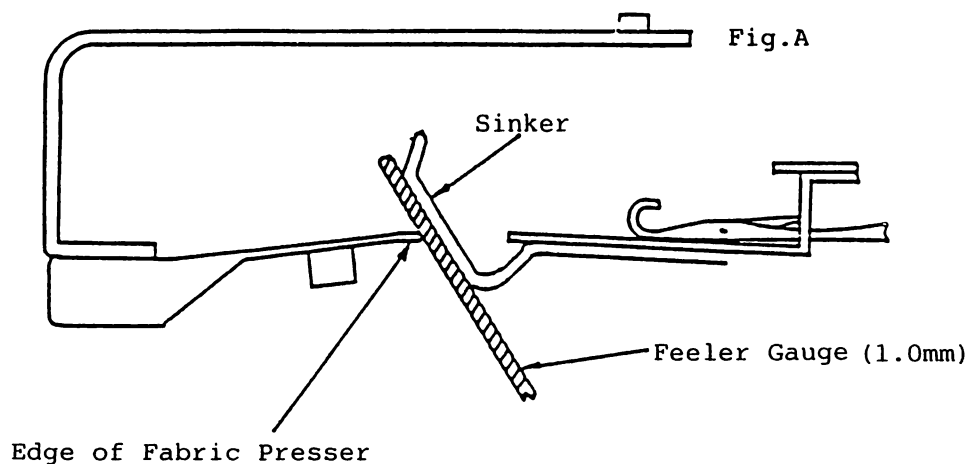

Fig.23

- b. Adjust the clearance between the edge of the Fabric Presser and the Sinkers so that it will fall within the range of 0.5 to 1.5mm, while measuring the clearance with a feeler gauge as indicated in Fig.A. Align both right and left Fabric Pressers horizontally as shown in Fig.B.



- c. When the adjustment has been completed, tighten four Binding Head Screws (3x3.5) and secure the Round Brush C and Rubber Gears.

4-5 YS Adjustment (Adjusting the clearance between Yarn Feeder and Sinkers)

1. YS dimension..... 0.3 to 1.0mm

(The clearance between the edge of Yarn Feeder and Sinkers)

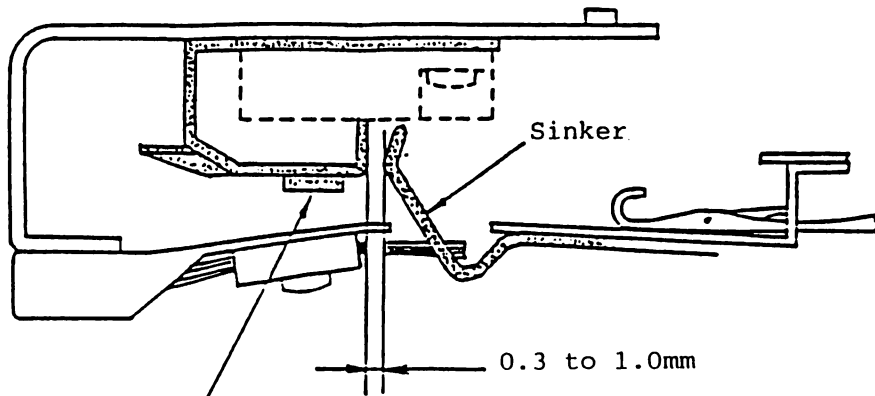

Fig.24

2. Adjusting Method

Loosen two Binding Head Screws (3x6) securing the Yarn Feeder and Latch Magnet Cover. Adjust the position of Yarn Feeder by moving it toward or away in the arrowed direction as shown in Fig.25.

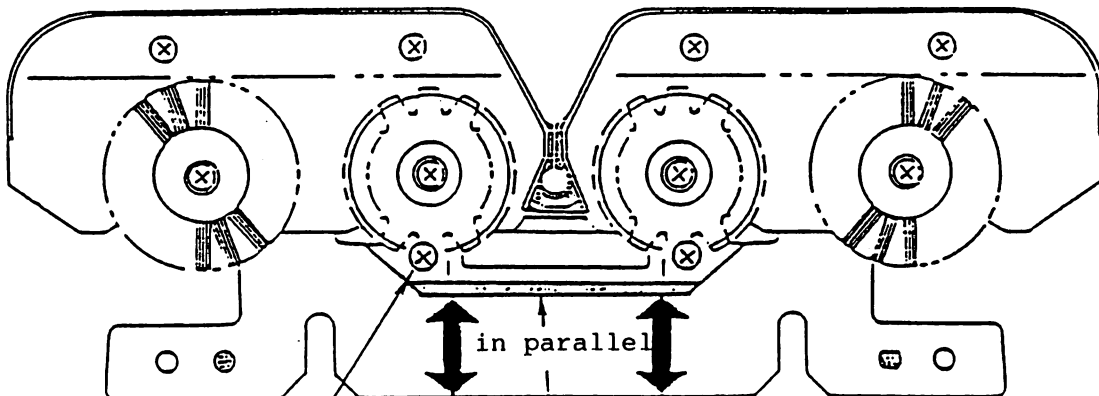
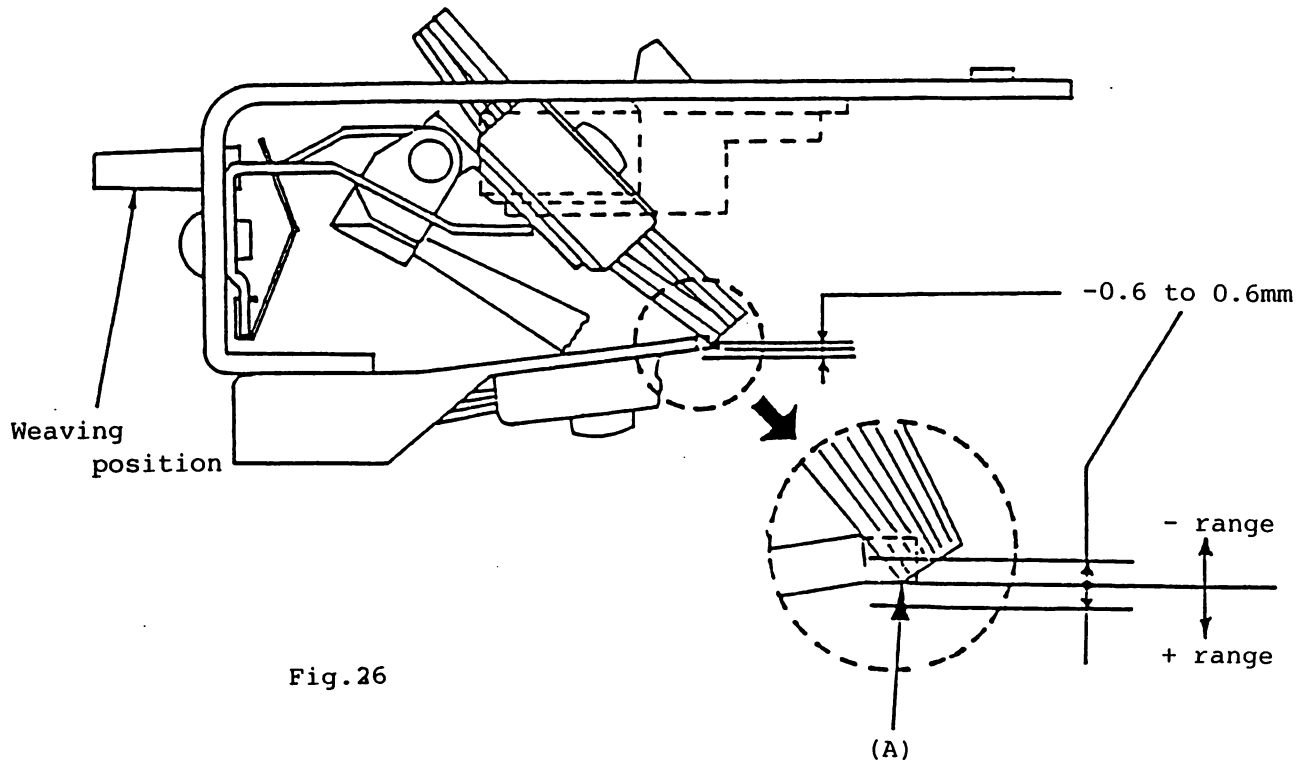

Fig.25

Binding Head Screw 3x6

4-7 Brush Holder Adjustment (up-down positioning)

1. The vertical clearance between the Weaving Brush and Fabric Presser (cut-out portion) -0.6 to 0.6mm



2. Adjusting Method

Set the Weaving Brush Knob to the "STOCKINET" position and adjust the angle of Weaving Brush, with the aid of a pair of pliers, by bending the tip of Brush Holder up and down as shown in Fig. 27.

