

**S I N G E R**  
f r e e s t y l e

**INSTRUCTION MANUAL**

# CONTENTS

|  |    |
|--|----|
| DESCRIPTION MAIN PARTS                     | 1  |
| ACCESSORIES                                | 2  |
| HOW TO SET UP YOUR MACHINE                 | 6  |
| THE NEEDLE BED                             | 11 |
| NEEDLES                                    | 14 |
| THE CARRIAGES                              | 15 |
| MAKING A JUMPER                            | 18 |
| V NECK RAGLAN SWEATER                      | 35 |
| WAISTCOAT WITH PICOT EDGING AND<br>POCKETS | 39 |
| FOR A MORE PROFESSIONAL TOUCH              | 47 |
| BUTTONHOLES                                | 52 |
| OTHER WAYS OF ...                          | 54 |
| FANCY STITCH PATTERNS                      | 63 |
| KNITTING WITH HEAVY YARN                   | 69 |
| CIRCULAR KNITTING                          | 71 |
| SOCKS IN CIRCULAR KNITTING                 | 74 |
| WHAT TO DO IF ...                          | 76 |

# DESCRIPTION – MAIN PARTS

## THE MACHINE

- 1 Space Selector Indicator
- 2 Needle Position Scale
- 3 Back Slide Rail
- 4 Front Needle Bed
- 5 Flow Combs
- 6 Thread Guide
- 7 Tension Adjustment Dial
- 8 Tension Unit
- 9 Span Wires
- 10 Row Counter
- 11 Back Carriage
- 12 Front Carriage
- 13 Bed Position Levers
- 14 Racking Handle
- 15 Intermediary Lever
- 16 Space Selector
- 17 End Cap
- 18 Front Slide Rail
- 19 Needle Rail

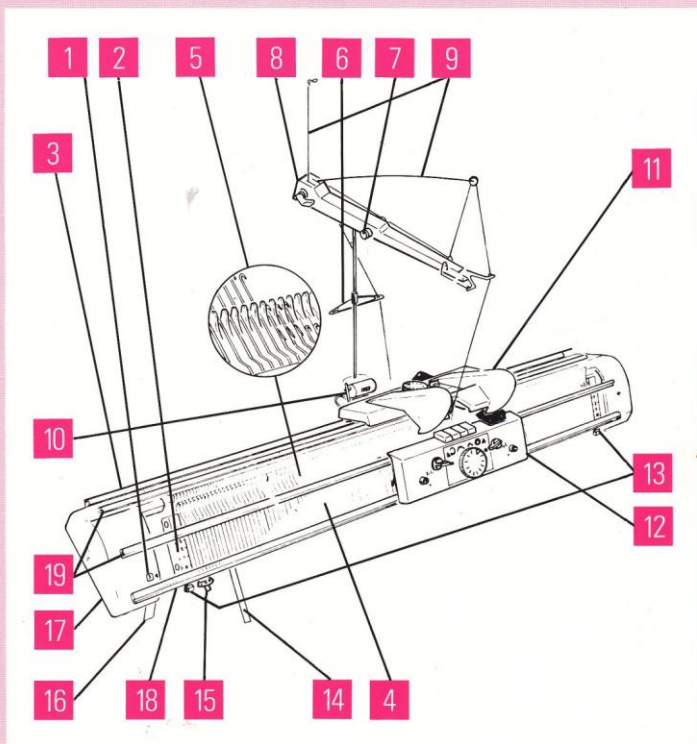

## THE CARRIAGES

- 1 Handles
- 2 Stitch Size Dial
- 3 Jacquard Key
- 4 Row Counter Cam
- 5 Coupling Catch
- 6 Needle Selection Buttons
- 7 Returning Levers
- 8 Selection Keys
- 9 Yarn Mouth
- 10 Locking Levers
- 11 Carriage Slide

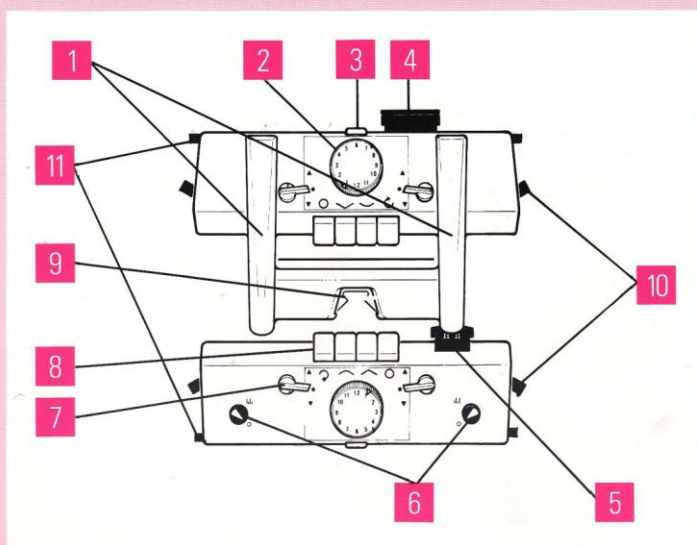

## ACCESSORIES

These accessories are provided with your machine. Other accessories are available from your local Singer Stockist.

Double Ended Eyelet Tool

Needle



Three Eyelet Transfer Tool



Single and Double Eyelet Transfer Tool

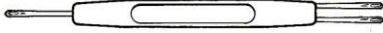

Hook and Latch Needle Tool



Twenty Eyelet Transfer Tool

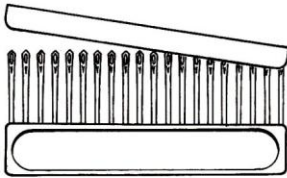

Needle Selector Tool  
1 × 1 and 2 × 1

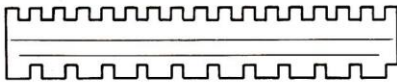

Needle Ruler





Large Weight



Small Weight (×2)



Claw Weight (×2)

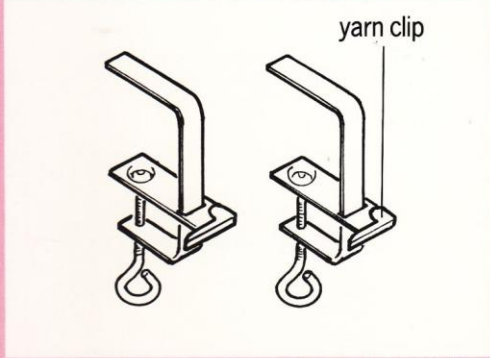
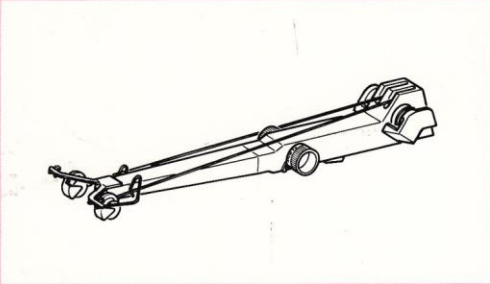
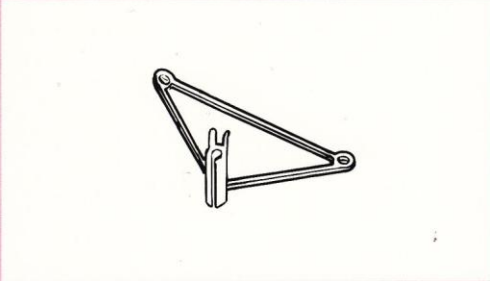

Table Clamps



Tension Unit



Thread Guide

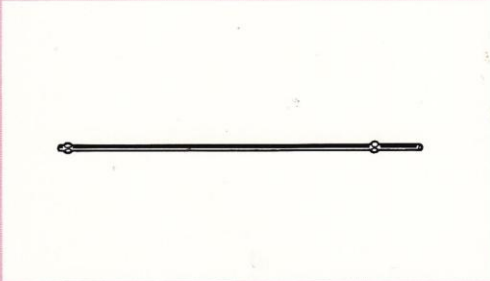

Tension Rod

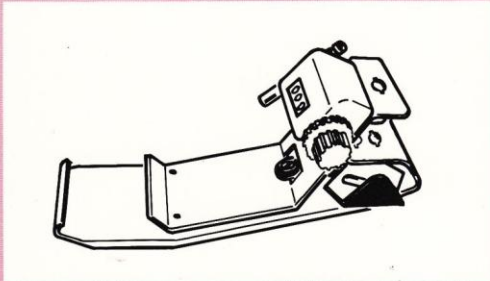

Tension Unit Stand and Row Counter



Transfer Carriage

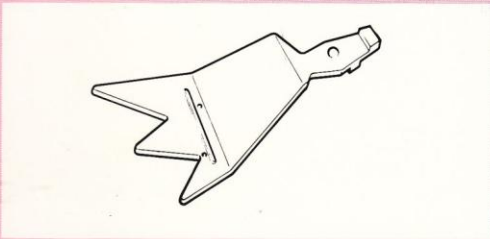

Jacquard Claw

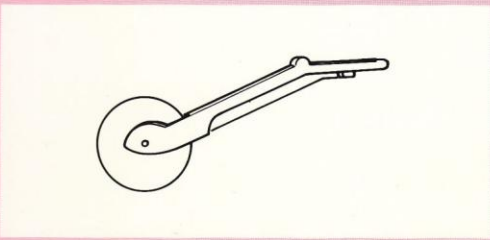

Heavy Yarn Wheel (×2)

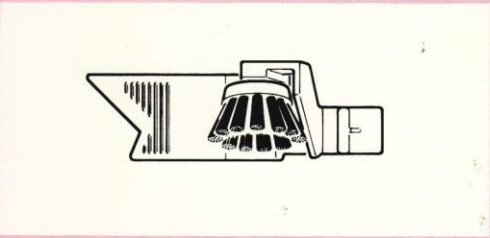

Weaving Brush (×2)

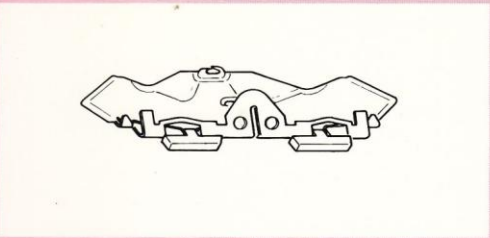

Second Colour Guide

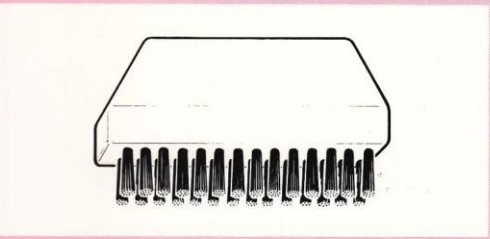

Cleaning Brush



Oil

# HOW TO SET UP YOUR MACHINE

1



1 Place the machine on the table with the word Singer on the left hand end cap facing the edge of the table.

2 Holding the front slide rail firmly turn the machine over so that back bed and carriage are laying on the table.

3 At each end of the machine there is a rubber foot attached to a metal plate. Carefully turn the machine over so that the word Singer is facing you again.

4 Move the machine forward so that the front edge of the rubber foot is level with the edge of the table.

**NB.** The machine must be supported as the front bed hangs over the edge of the table.

Use the table clamps to fasten the machine to the table. Lay the upper part of the clamp over the metal plate and rubber foot. The moveable plate passes under the table top. Tighten the screws so the machine is firmly attached to the table, as illustrated.

2



3

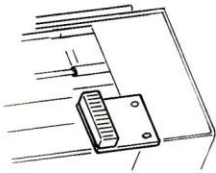

4

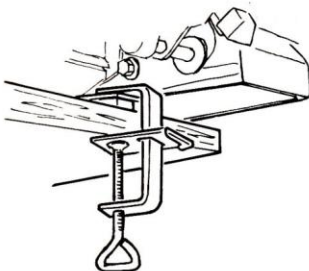



5

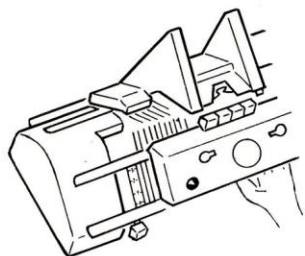

5 Slide your hand under the left hand side of the needle bed as illustrated until you feel the racking lever.

6 Hold the racking lever and move it gently to the left until it clicks into position, as illustrated.

7 Move the racking lever towards the left until it clicks again. This action will move the front bed to the left.

8 Carefully remove the packaging from the right hand side of the front needle bed, as illustrated.

Move the racking lever to the right until it clicks twice. Remove the packaging from the left hand side of the front needle bed.

Move the racking lever to the left until it clicks once so that it resumes its original position.

6

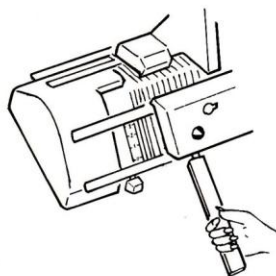

7



8

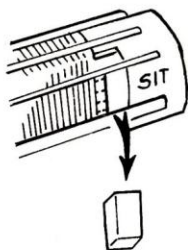

9

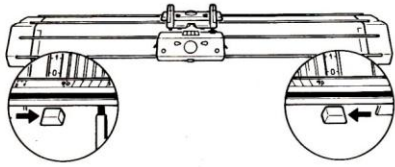

9 Take hold of the bed positioning levers and press firmly towards the centre of the front bed to unlock the locking levers and then gently pull down.

10

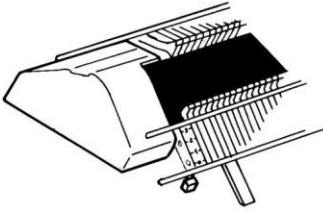

10 The front bed will move down to a lower position, as illustrated.

11 Hold the row counter and tension unit stand as illustrated and ease the black lever on the right forwards.

12 Slide the row counter and tension unit stand under the centre of the back bed, as illustrated.

13 Position the row counter so that the curved edge hooks onto the ridge on the underside of the back bed, as illustrated.

11

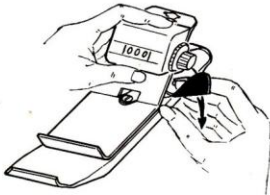

12

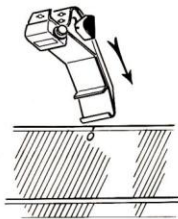

13

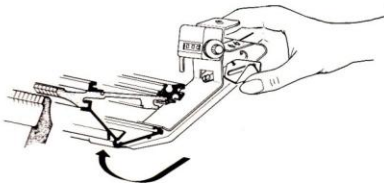

14

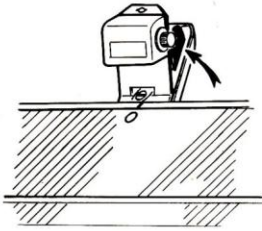

- 14 Once the unit is correctly positioned push the black lever firmly towards the row counter until it snaps into position.

Place your hands under the front bed slide rail and push upwards until the front bed is level with the back bed.

15



- 15 The tension rod has two bumps approximately one inch from one end and two bumps a quarter of an inch from the other end.

- 16 Lay the tension rod on a flat surface and press the tubular shaped part of the yarn guide firmly onto it, as illustrated, with the two prongs pointing towards the bumps one inch from the end, until it snaps into position.

16

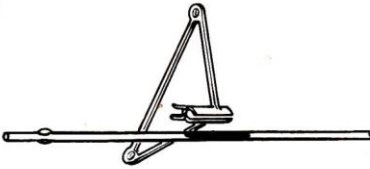

- 17 With the two bumps a quarter of an inch from the end pointing downwards, insert the tension rod into the two holes in the back and base of the row counter and tension unit as illustrated. Rotate the rod until the bumps drop through the bottom hole and the rod is unable to move freely when rotated.

- 18 On the underside of the tension assembly there is a hole. Position the hole above the tension rod and push down gently until the bumps are positioned in the slot and the assembly cannot move freely when moved from side to side.

17

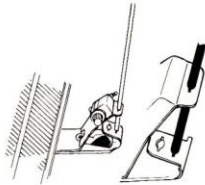

18

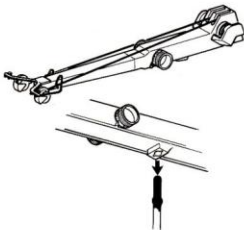

19

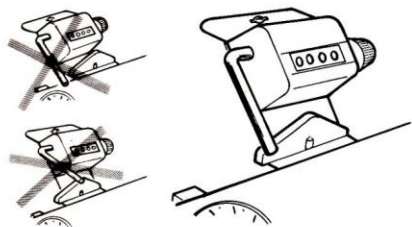

- 19 Slide the carriage across to the row counter. Move the row counter lever up or down so that it is positioned on the row counter cam as illustrated.

Move the carriage backwards and forwards, making sure the numbers change each time the row counter cam passes the lever.

- 20 To reset the row counter to 0 push in on the knob and turn it towards the front of the machine.

To add, turn the knob to the front.

To subtract, turn the knob towards the back.

20

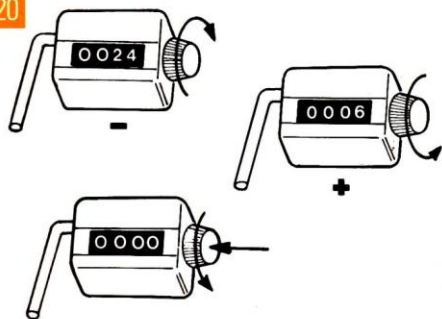

# THE NEEDLE BED

1

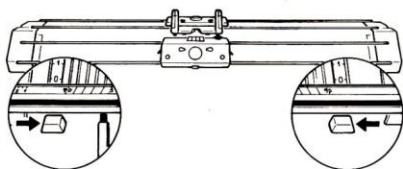

2

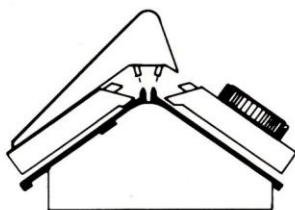

3

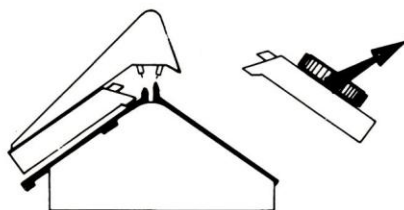

4

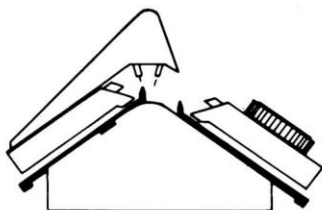

The back bed is permanently fixed in one position but it is very helpful during the course of knitting garments to be able to move the front bed up and down.

- 1 The front bed can be moved to 4 different positions, each of which has a use in knitting. It is easily moved by pushing both the bed position levers towards the centre of the bed simultaneously, which releases the mechanism which locks the front bed in position.

By pushing in on the levers and then pushing upwards or downwards, different positions can be obtained.

- 2 Working Position.

This is when both beds are at the same level. It is normally used when casting on, making ribs, making fairisle patterns and for double bed knitting.

- 3 Upper Position.

By pushing the bed positioning levers towards the centre and then pushing upwards the front bed can be raised slightly above the back bed.

The front carriage can be removed or pushed to the end of the machine when the front bed is raised as only the back carriage is used for knitting.

This position is normally used for stocking stitch and single colour patterns such as tuck and slip patterns on the back bed.

- 4 Intermediate Position.

By pushing the bed positioning levers towards the centre and then pulling down gently the front bed can be lowered. It is used for checking the knitting and can also be used when transferring stitches from the back bed to the front bed manually.

5

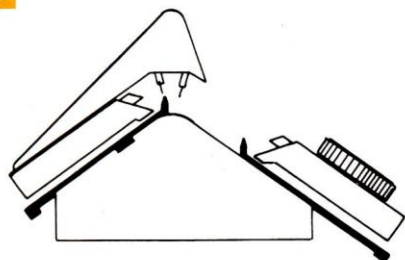

6

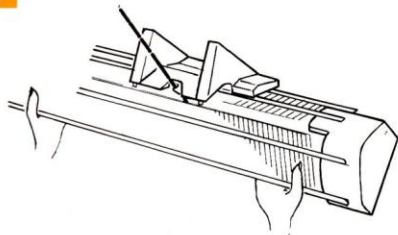

7

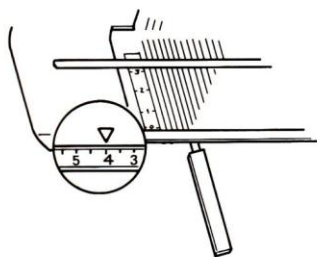

8

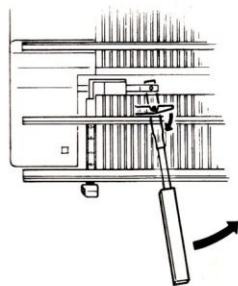

## 5 Lower Position.

By continuing to pull gently downwards after pushing the bed positioning levers in after intermediary position has been obtained, the front bed can be lowered even further.

This position is used in casting off, checking knitting, picking up stitches and counting rows.

6 The bed is easily returned to working position from the lower or intermediary positions by gently pushing upwards while holding the front bed, as illustrated. To return the bed to working position from the upper position it is necessary to push the bed positioning levers towards the middle and then ease the bed downwards.

7 The front bed can also be moved sideways to the right or left by moving the racking lever. Each movement of the lever moves the bed along by 5mm - the distance between each needle. It is used in the formation of racking patterns or in conjunction with the intermediary lever to allow all the needles to be used on both beds simultaneously for double bed patterns such as jacquard.

8 When not in use the racking lever can be folded away under the front bed by pulling on the locking lever (visible behind the front needle bed when the bed is in the lower position) and pushing the lever to the right.

It is brought into working position by holding the lever and moving it to the left.

9

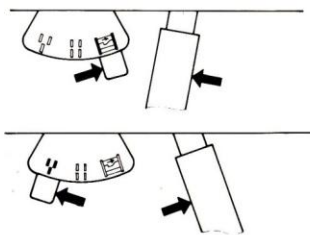

9 By positioning the intermediary lever together with the racking lever the front bed can be moved to any of 3 positions which govern the position of the front bed needles relative to those on the back bed.

10



10 Needles Opposite - used in casting on ribs and in pattern work on the back bed. The intermediary lever is set to the central position.

11



11 Needles Alternate - used when all needles on both beds are needed to work simultaneously. The racking lever and intermediary lever are pushed apart, so that the intermediary lever is set to the left hand position. Used for close ribs, jacquard and double bed pattern work.

12 Quarter Pitch Position - used when transferring stitches from one bed to the other, for example when changing from rib to stocking stitch with the transfer carriage. The intermediary lever and racking lever should be squeezed together. The racking lever is then moved one position to the right.

12



13 The space selector adjusts the space between the beds from 3 to 6 millimetres. If a thick yarn is being used more space is needed between the beds to allow the knitting to feed through easily. If a fine yarn is used less space is needed.

| Type of yarn            | Bed space |
|-------------------------|-----------|
| Fine (2 ply)            | 3         |
| Medium (3-4 ply)        | 4-5       |
| Thick (Double Knitting) | 6         |

13

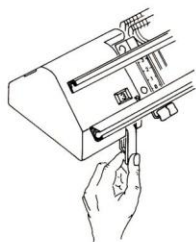

# THE NEEDLES

1

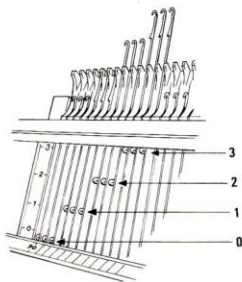

Every fifth needle is numbered for easy reference when following pattern shapings. **Always start your knitting by selecting needles either side of 0 found in the centre of the needle bed.**

1 There are 180 needles on each bed, each sitting in its own groove. There are 4 positions for each needle.

0 = Non-working position

1 = Working Position 1

2 = Working Position 2

3 = Holding Position 3

2

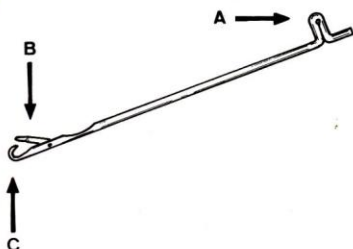

2 Each needle has 3 main parts.

A. The heel - the part of the needle which comes into contact with the carriage.

B. The latch - the part which opens or closes the hook during stitch formation.

C. The hook - the part which retains the stitch when the yarn is placed into it.

3

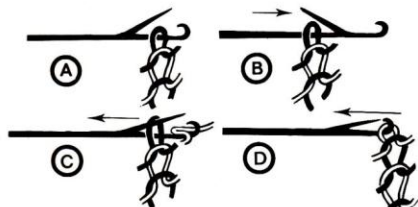

3 Stitches are formed by the movement of the needle up and down in the groove as the carriage passes across.

A. The needle starts to form the new stitch in working position 1 with a stitch in the hook of the needle.

B. As the carriage moves across the needle moves forwards to working position 2 and the stitch slides behind the latch.

C. The yarn is placed in the hook of the needle from the yarn mouth and the needle begins to move back to working position 1.

D. When moving downwards the stitch closes the latch and slips over the needle and a new stitch is formed.



# THE CARRIAGES

1

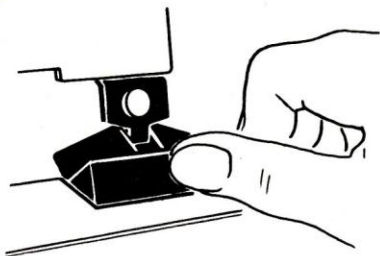

1

The machine has two carriages. When the front carriage is not in use, ie. for stocking stitch on the back bed, it can be separated from the back carriage by pushing down on the coupling catch, as illustrated and sliding the front carriage to either the right or left.

To join the carriages together, hold the back carriage by the handle and move the front carriage across until the prong on the back carriage slides into the coupling catch.

2

The carriages are held in position by two black locking levers which lock the carriage to the needle rail.

If it is necessary to remove the carriages the locking levers should be pushed towards the handles, as illustrated, simultaneously. The carriage should also be tilted away from the needle bed at the same time. With the carriage held away from the needle heels to avoid damage it can be moved to the end of the machine and removed. **NB.** The back carriage must always be removed first.

To replace the carriage on the bed the carriage slide should be inserted into the slide rail and moved along so that the carriage is opposite the needle bed. Tilt the carriage forward so that it is resting on the needle rail and lift the locking levers simultaneously. The carriage will drop onto the needle rail and by releasing the locking levers will be secured onto the bed.

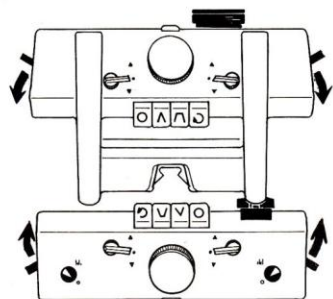

3

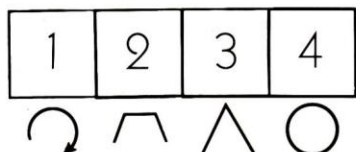

3

Each carriage has 4 keys for basic stitches which are operated by being pressed parallel to the handles until the top of the key is level with the top of the carriage. Pressing the keys alters various moving parts or cams on the under side of the carriage.



**The circular knitting key.** When depressed on both carriages the yarn is fed to the needles on the front and back beds alternately so that the knitting is formed in a circle. This is useful for seamless garments such as socks and scarves.



**The tuck key.** When this key is pressed during patterning the needles selected to form the pattern do not knit a stitch, instead the yarn is laid over the needle forming a loop.

4

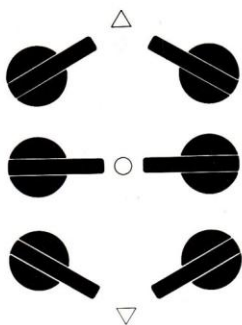

**The knit key.** When this key is pressed down all the needles knit to form stocking stitch.



**The cancel and slip key.** This key acts as a release key and will, when depressed, return other keys to their original position.

This key does not remain depressed but will always return to the original position. **The cancel key should always be pressed to release a key before another one is selected.**

5

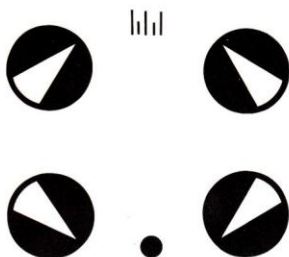

4

Both carriages have two levers below the selection keys. The needle return levers have 3 positions - upper, lower and neutral.

1. Upper positions - when the needle returning levers are pointing towards the handles on the carriage. The carriage is set to do 2 colour work, ie. fairisle.

2. Neutral position - in this position the needle return levers are not working.

3. Lower position - in this position the needle return levers will bring any needles in holding position back to working position 1.

5

The needle selection buttons are on the front carriage only. They are operated by pushing the buttons in and turning them simultaneously.

(a) **In the upper position**, ie. pointing towards the handles of the carriages, they will select alternate needles on alternate rows to create fancy patterns.

(b) **In the lower position**, ie. pointing towards the needle rail, the needle selection buttons are not working.

6

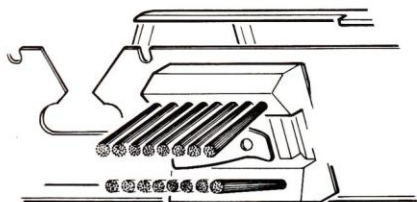

6

The latch brushes are located under the handle of the back carriage. They open the latches of needles before the yarn is laid into the hook to make a new stitch.

7

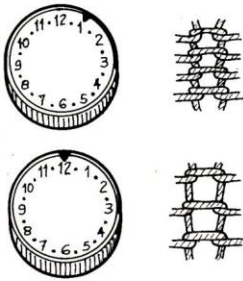

7 The stitch size dial determines the size of the stitch.

If the dial is turned so that the pointer is opposite a low number a small stitch is produced.

If the dial is turned so that the pointer is opposite a high number a large stitch is formed.

| Stitch Size Dial | Description of Yarn               | Hand Knitting Needles mm |
|------------------|-----------------------------------|--------------------------|
| 1-3              | Fine yarn                         | 2-2½                     |
| 3-5              | 3 Ply                             | 2½-3                     |
| 5-7              | 4 Ply                             | 3-3½                     |
| 7-9              | Baby DK                           | 3½-4                     |
| 8-12             | Double knitting and heavier yarns | 4+                       |

8

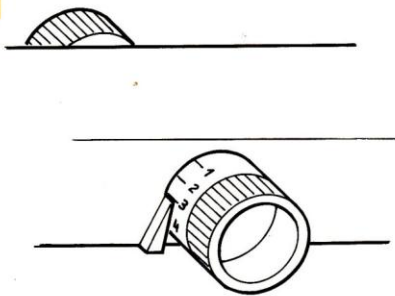

8 The tension of the yarn can also affect the size of the stitch. The tension is determined by the number on the wheel illustrated.

For fine yarns, i.e. 2 ply the dial should be set to 1, 2 or 3.

For medium yarns, i.e. 3 or 4 ply the dial should be set to 4, 5, 6 or 7.

For heavier yarns, i.e. double knitting, the dial should be set to 8, 9 10 or 11.

# MAKING A JUMPER

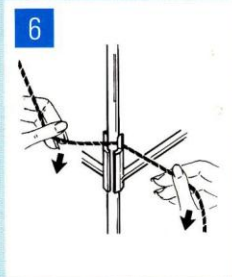
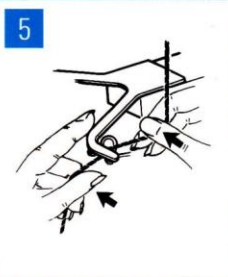
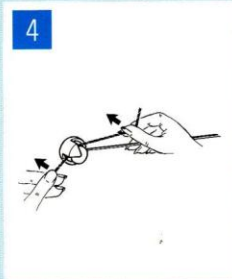
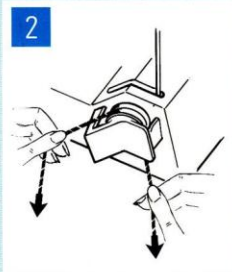
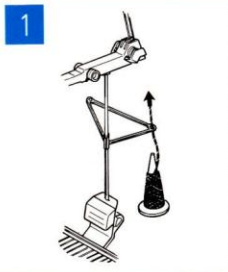

## THREADING THE MACHINE

- 1** Place the cone of yarn on the floor behind the machine.  
Thread the end of the yarn through the right hand thread guide.
- 2** Hold the end of the yarn in your left hand. Lay the yarn over the discs with the end of the yarn towards the front of the machine. Holding the yarn firmly, pull down gently as illustrated, so that the yarn slides between the discs.
- 3** Holding the yarn, as illustrated, with the end towards the front of the machine, pass the yarn behind the wire and guide it up so that it rests inside the  $\cap$  of the wire.
- 4** With the end of the yarn towards the front of the machine, hold the yarn, as illustrated, against the V of the white plastic. Pull gently with both hands and the yarn will move under the V and over the white wheel.
- 5** With the end of the yarn towards the front of the machine slide the yarn under the white plastic guide and into the metal guide.
- 6** Holding the yarn as illustrated, pull down gently so that the yarn is firmly held in the yarn holder.

7

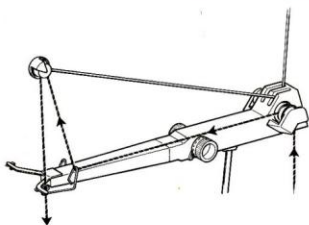

7 Check that the tension unit is threaded correctly, as illustrated.

8

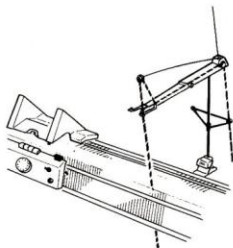

8 Drop the front bed down by pushing the bed position in levers towards the centre of the front bed and then pulling down gently on the front bed.

Release the yarn from the yarn holder and guide the end of the yarn between the beds.

9

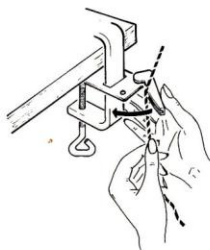

9 Clip the yarn in the yarn clip on the right hand table clamp.

10

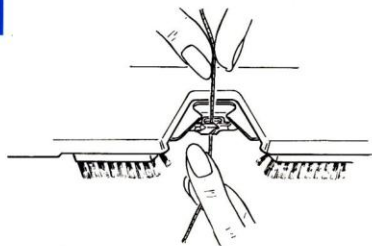

10 Thread the yarn through the yarn mouth on the back carriage, as illustrated.

11

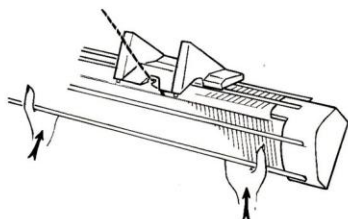

11 Push the front bed back to working position, as illustrated, and move the carriages to the right hand side.

Make sure that the carriages are joined together.

1



2

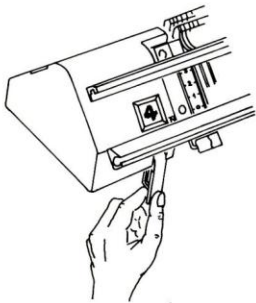

3

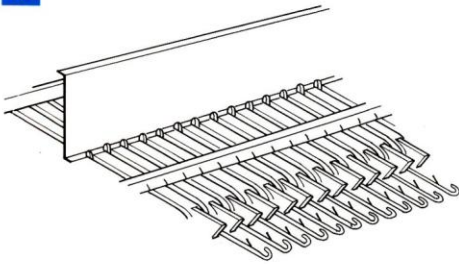

4

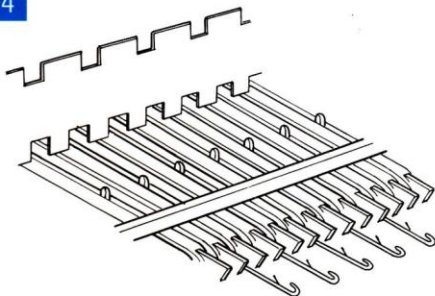

## CHECKING THE BED POSITION

1 Make sure that the intermediary lever is in the centre position, as illustrated. The needles are now opposite each other as illustrated.

2 Move the bed space lever until 4 shows in the window.

## STARTING THE RIB

3 Use the needle ruler to move the number of needles given for your size in the pattern to working position 2 on the back bed. Be sure to centre them on the needle bed equally each side of "O".

4 Use the 1 × 1 selector tool to return the alternate needles to non working position (position 0).

Move the remaining needles to working position 1 so that the hooks are level with the flow combs.

5



! = needle in working position 1  
- = needle in non-working position 0

6

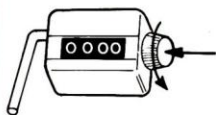

5 Repeat steps 3 and 4 on the front bed, making sure that the needles opposite to those in working position 1 on the back bed are returned to non working position 0.

The needles should now be arranged as illustrated.

6

Set the row counter to 000. See page 10.

7

Set the stitch size to 1 on both carriages.

Set the returning levers to the central position.

Set the needle selection buttons to the lower position.

Depress the knit "V" key on both carriages.

7

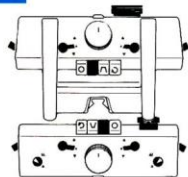

8



8

Holding the handle, as illustrated, move the carriage across the needles to the left until it has cleared the last needle in working position.

9

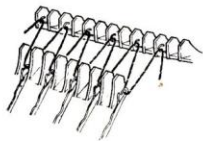

9

The yarn is now zig zagged between the needles on both beds. As illustrated.

10

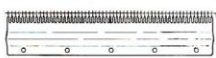

10

Remove the wire from the comb by pulling on the bent end of the wire.

For sizes 24 to 26 use the smaller comb.

For sizes 28 to 44 use the large comb.

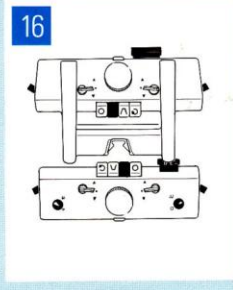
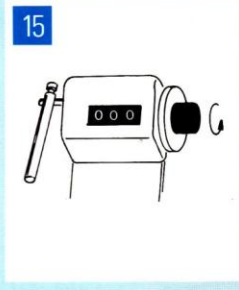
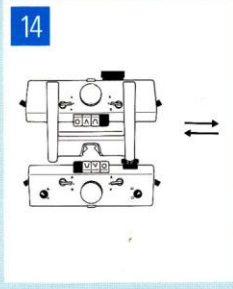

**11** Move the comb under the front bed and raise it so that the teeth of the comb are through the zig zags formed by the yarn.

The centre of the small comb is marked in a different colour. This marker should be opposite 0 in the centre of the needle bed.

The large comb does not have a mark but the first tooth at each side of the comb should be level with the end of the bed.

**12** With the comb still raised, re-insert the wire into the comb from the right-hand side. Make sure the wire goes all the way through the comb and the bent end is facing downwards.

**13** Insert two small weights into the holes in the comb which are closest to the first and last needles in working position 1.

**14** Press the cancel key 0 on both carriages.  
Press the circular knitting key  on both carriages.

Set the stitch size dial to 2 on both carriages.  
Knit 2 rows.

**15** Set the row counter to 000.

**16** Press the cancel key 0 on both carriages.  
Press the knit key V on both carriages.  
Set the stitch size to 4 on both carriages.  
Set the row counter to 000.

Knit the number of rows given for your size on the pattern ending with the carriages on the right.



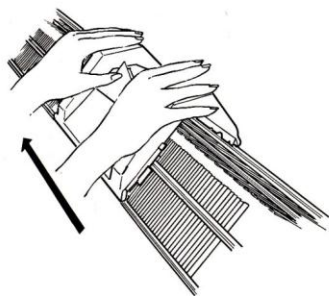

## TRANSFERRING TO STOCKING STITCH

- 17 Increase the stitch size on the front carriage only by one full number. Knit 1 row so that the carriages are on the left. Move them to the far left of the machine.
- 18 Squeeze the intermediary lever and racking lever together, so that the intermediary lever is on the right. Move the racking lever 1 position to the right. See page 13.
- 19 Bring up all the needles in non-working position 0 on the back bed to working position 1. Make sure the needle heels are in a straight line.
- 20 Place the transfer carriage on the machine so that the hook is between the beds. The word Singer should be facing you and the arrow pointing to the left.
- 21 Hold the transfer carriage as illustrated. Press down on the carriage so that the bottom of the transfer carriage is touching the slide rails on both sides.
- 22 While maintaining the pressure on the carriage, move it to the left across the needles.
- 23 The stitches on the front bed have now been transferred onto the empty needles on the back bed.
- 24 Lift the carriage from the machine.
- 25 Push the empty needles on the front bed to non-working position 0.
- 26 Push the intermediary lever and the racking lever apart so the intermediary lever is in the centre. Then move the racking lever to the left. The needles are now opposite each other. See page 13.

27

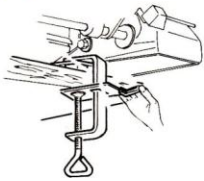

28

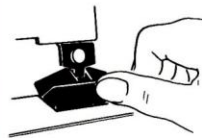

## STOCKING STITCH

27 Release the yarn from the clip on the right hand table clamp.

28 Release the front carriage by pressing on the coupling catch.

29 Slide the front carriage to the extreme right of the machine so that it is out of the way.

30 Move the bed space lever so that 5 is showing in the window.

31 Push the bed position levers towards the centre of the bed and then push upwards so that the front bed is slightly higher than the back. See page 11.

32 Set the row counter to 000.

29

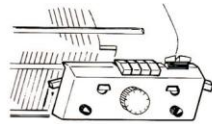

30

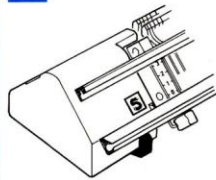

31

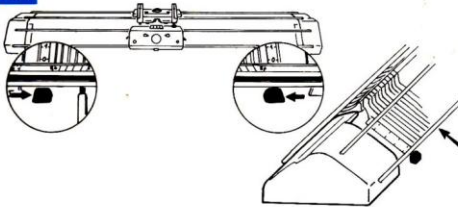

32

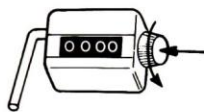

33

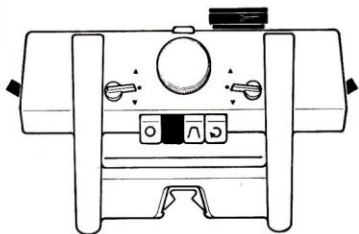

38



39

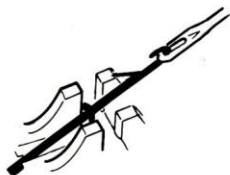

40



41

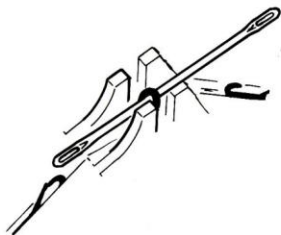

- 33 Press the cancel key 0 on the back carriage. Press the knit key V on the back carriage. Set the stitch size dial to 6 on the back carriage.

Knit as many rows as needed for your size in the pattern.

### TRANSFERRING FROM STOCKING STITCH TO RIB

- 34 Drop the front bed down so that it is level with the back bed.  
Move the space selector lever until 4 is showing in the window.
- 35 Rejoin the front and back carriages by pushing the front carriage across until the prong slides into the coupling catch.
- 36 Using the needle ruler, bring the same number of needles to working position 1 on the front bed as there are on the back bed.
- 37 Use the 1 × 1 selector tool to return alternate needles on the front bed to non-working position 0.
- 38 Place one end of the double eyed eyelet tool over the hook of the first needle on the right of the back bed with a needle opposite it in working position 1 on the front bed.
- 39 Keeping the tool parallel with the needle, pull the needle forward to working position 2 so that the stitch slips behind the latch.
- 40 Keeping the tool parallel with the needle, push the needle to non-working position 0. The stitch has now slipped onto the tool.
- 41 Release the eye of the tool from the hook of the needle on the back bed.

42



42 Use the other end of the tool, place the eyelet over the hook of the needle in working position 1 on the front bed.

43 Tilt the tool forwards so that the stitch slides down onto the hook of the empty needle and release the eye from the hook of the needle.

Repeat the above until all the alternate stitches from the back bed have been transferred onto the front bed.

Move all the empty needles on the back bed to non-working position 0.

43

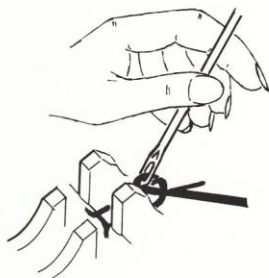

44 Press the V key down on the front carriage. Set the stitch size dial to 5 on both carriages.

Set the row counter to 000.

Knit the number of rows given for your size in the pattern.

45 Follow steps 17-26 to transfer all the stitches to the back bed.

Set the stitch size dial to 7 and knit 1 row.

46

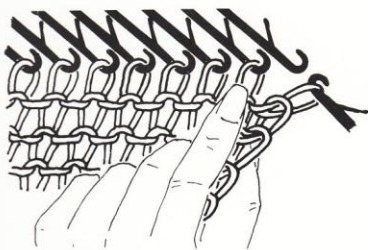

#### CASTING OFF

46 With the thumb and forefinger hold the knitting in your left hand, as illustrated. Pull the knitting slightly to open the stitches.

Using the latch tool, unhook the first stitch on the side next to the carriage.

47 Slide the stitch behind the latch. Keeping the latch open, unhook the second stitch and slide this behind the latch. (Two stitches behind the latch.)

47

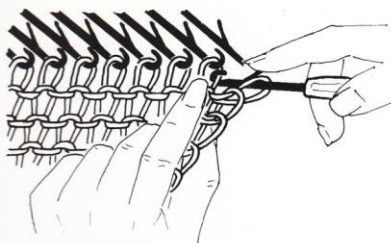

48

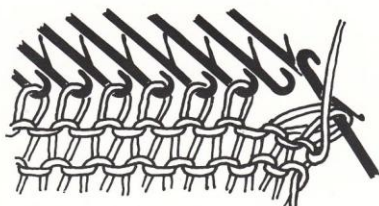

48 Lay the yarn over the hook of the tool.

49

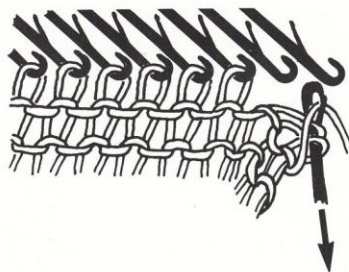

49 Pull the tool downwards to pass the yarn through both stitches.

A new stitch is formed.

Hook the next stitch, let both stitches slide behind the latch of the tool.

Lay the yarn over the hook.

Pull the yarn through both stitches. Continue across to the last stitch.

50 Break the yarn and pull it through the loop of the last stitch.

Remove the comb and weights from the knitting.

51 Repeat the instructions for the second part of the body of the garment.

## SLEEVES

52 Using the number of needles given for your size in the pattern, cast on for the rib as for the back (see page 20) and knit the rib. When you have completed the rib transfer all the stitches to the back bed (see page 23). Change to stitch size 6 and knit the number of rows given in the pattern to the first increase.

50

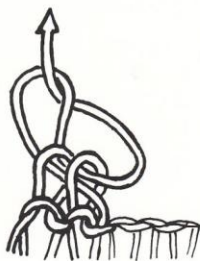

## SIMPLE INCREASE

53 On the carriage side of the knitting move one needle to working position 1. When the carriage is taken across the needles the extra one will also be knitted.

Do the same on the other side of the knitting on the next row.

54 Follow the pattern, increasing where necessary and when you have completed the sleeve cast off. See page 26. Repeat the instructions for the second sleeve.

53

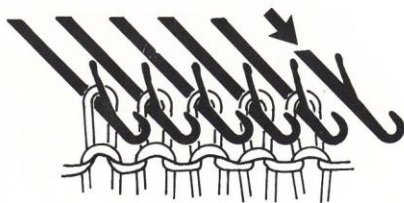

1

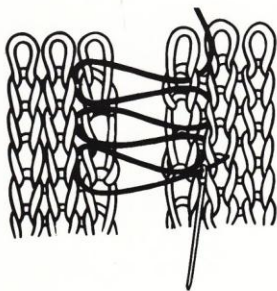

## FINISHING YOUR GARMENT

1 To seam together vertical seams a number of methods can be used.

One of the most professional finishes can be obtained by using an invisible seam.

Place the 2 edges side by side with the right side of the work facing upwards.

Using a tapestry needle and matching thread, pass the needle under the loop formed between the edge stitch and second stitch.

Pull the yarn gently so that the stitches of the 2 pieces meet.

Continue taking one loop from each side and drawing the yarn up after every few stitches.

2



4



5

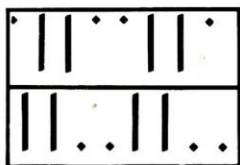

6

| CARRIAGES | KEY | STITCH | N.R.L. | N.S.B. |
|-----------|-----|--------|--------|--------|
| BACK      |     |        |        |        |
| FRONT     |     |        |        |        |

9

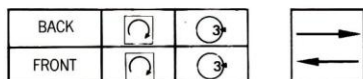

## ROUND NECK SET IN SLEEVE JUMPER

2 × 2 simple rib.

### THE BACK

- 1 Set the space selector so that 4 is showing in the window.
- 2 Make sure that the intermediary lever is in the centre position and that the flow combs are opposite each other.  
The carriages are on the right.
- 3 Bring up all the needles given for your size in the pattern on both beds to working position 1.
- 4 Move the intermediary lever to the left and the racking lever one position to the right simultaneously.  
The needles are now alternate.
- 5 Return needles to non working position so that the needle arrangement illustrated is achieved.  
l = needle in working position 1.  
• = needle in non-working position.
- 6 Press the knit key V down on both carriages.  
Set the stitch size dial to 1 on both carriages.  
The needle returning levers are in the centre position.  
The needle selection buttons are down.
- 7 Thread up the machine.  
Move the carriage to the left.
- 8 Insert the cast on comb and wire.  
Place the small weights on the comb as close as possible to the last needle in working position at both ends of the comb.
- 9 Press the cancel key 0 on both carriages.  
Press the circular key on both carriages.  
Set the stitch size dial to 3 on both carriages.  
Knit 2 rows.

10

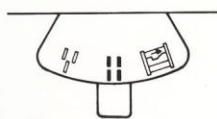

|       |           |
|-------|-----------|
| BACK  | • • • • • |
| FRONT |           |

12



13

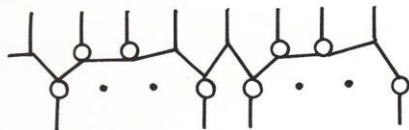

14



15

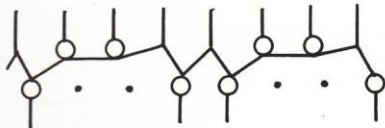

17



10 Move the intermediary lever to the centre position and then move the racking lever 2 positions to the left so that the needles are opposite, as illustrated.

11 Set the row counter to 000 and the stitch size to 5 on both carriages and knit the number of rows in rib given for your size in the pattern, ending with the carriages on the right.

### TRANSFERRING TO STOCKING STITCH

12 Increase the stitch size by one number on the front carriage. Knit 1 row.

Move the intermediary lever to the left and the racking lever one position to the right. The flow combs are now alternate.

Bring the empty needles in non working position 0 on the back bed to working position 1.

13 Knit 1 row and move the carriages to the far left of the machine. The last row that you have knitted will look as illustrated.

14 Move the intermediary lever to the centre position and the racking lever one position to the left. The flow combs are now opposite.

15 Move the intermediary lever to the right and then move the racking lever one position to the right. The needles are now as illustrated.

16 Place the transfer carriage on the right of the bed with the arrow and the word Singer facing you. Press down firmly on the carriage so that the bottom of the transfer carriage touches the slide rail on both beds. Without releasing the pressure move the carriage smoothly to the left. The stitches on the front bed have now been transferred to the needles on the back bed.

17 Remove the transfer carriage from the machine. Move the intermediary lever to the centre position and then move the racking lever one position to the left, the flow combs are now opposite. Move the empty needles on the front bed to non-working position 0.



18

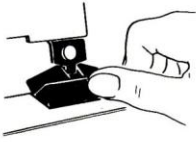

21

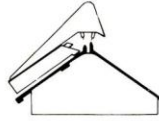

18 Detach the front carriage by pressing on the coupling catch and move the front carriage to the left of the front bed out of the way.

19 Set the row counter to 000.

Set the stitch size dial to 7 on the back carriage.

20 Move the space selector until 5 shows in the window.

21 Press the bed position levers towards the centre of the front bed and then push upwards so that the front bed moves to the upper position.

Release the yarn from the yarn clip.

22 Knit the number of rows given for your size in the pattern up to the armhole shaping.

23



24

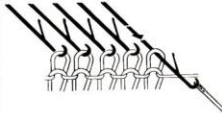

### ARMHOLE SHAPING - SET IN SLEEVE

Casting off several stitches.

23 Hold the eyelet tool in your hand like a pencil.

24 Hook the single eyelet of the eyelet tool into the hook of the needle holding the end stitch. Pull the tool towards you, keeping the needle and eyelet tool in a straight line. The stitch slides behind the needle latch.

25

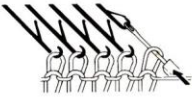

26



25 Push in on the needle. The stitch moves onto the eyelet tool.

26 Remove the eyelet tool from the needle, being careful not to drop the stitch.

Hook the eyelet tool onto the next needle in working position 1.

27

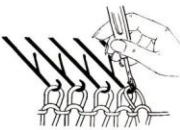

28



27 Tilt the tool towards the back. The stitch slides onto the new needle hook.

28 Bring the needle out to working position 2, making sure that both stitches slip behind the latch. Push the empty needle down to non-working position 0.

29

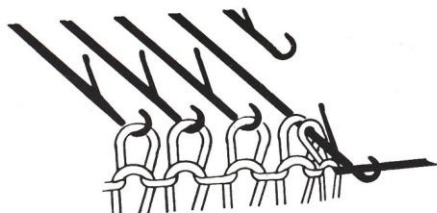

30



33

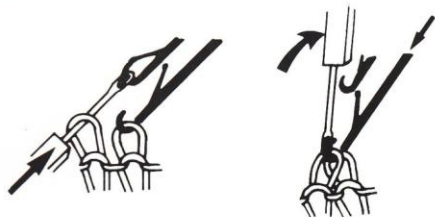

29 Place the yarn over the hook of the needle.

30 Lower the needle to working position 1 to form a new stitch.

Repeat this operation until the required number of stitches have been cast off.

31 Knit 1 row and cast off the same number of stitches from the other side.

32 Knit the number of rows given in your pattern until the first decrease.

#### DECREASING 1 STITCH

33 Using the single eyelet tool transfer the stitch at each end onto the next needle in working position 1 as illustrated.

Move the just emptied needle down to non-working position 0.

34 Carry on decreasing as given in the pattern for your size until the shaping is complete.

35 Knit the rows given without shaping that the pattern gives for your size.

36 Shape the shoulders by casting off the number of stitches on each row for your size in the pattern using the method for decreasing several stitches above.

#### THE FRONT

37 The front of the jumper is exactly the same as the back except for the neck shaping. Your pattern will tell you exactly which row to start the neck shaping for your size.

Follow the pattern for the back until the neck shaping.

38 Using a piece of matching yarn clipped to the right hand yarn clip, cast off the centre stitches given for the neck in your size using the method used for decreasing several stitches given above.

40

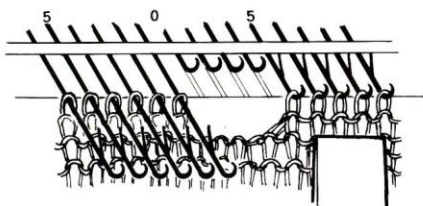

43

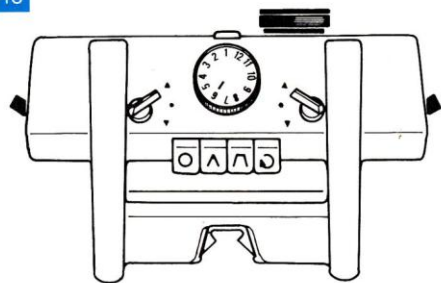

46

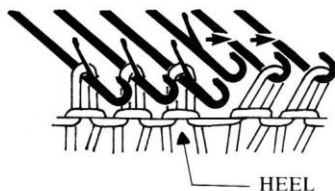

47

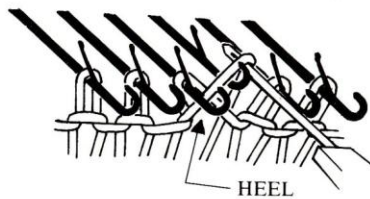

39 Bring up all the needles on the left of 0 to holding position 3. When the needles are in this position they do not knit.

40 Place the claw weights under the needles in working position 1 on the right of the cast off stitches.

41 Using the single eyelet tool, decrease 1 stitch as shown above on the neck edge as given in the pattern for your size, moving the claw weights up every 4-6 rows. Knit any rows without shaping given for your size in the pattern. Cast off for the shoulders as you have already done for the back. Return the empty needles to non-working position 0.

42 Once this casting off is completed pull the yarn through the yarn mouth while the carriages are on the right. Attach the yarn to the left hand yarn clip and bring it under the needles in holding position 3.

43 Move the needle returning levers to the lower position and take the carriages to the left. The needles have now been returned to working position 1 and a row has been knitted.

Knit the other side of the neck to match reversing the shapings.

## THE SLEEVES

44 Using the number of needles given for your size cast on the rib and transfer the stitches as given for the back.

Change to the main stitch size and knit the number of rows given in your size in the pattern until the first increase.

## FULLY FASHIONED INCREASE

45 This method of increasing allows you to increase on both sides of the knitting at the same time, and adds a decorative and professional finish to your work.

46 Using the double eyelet tool transfer the two edge stitches on each side one needle out.

47 Using the single eyelet tool take the heel of the next stitch and hang it onto the empty needle. This prevents a hole from forming.

50

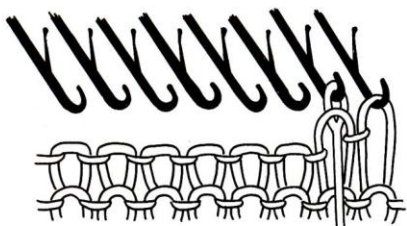

52

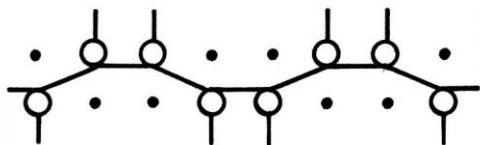

48 Follow the pattern, increasing where necessary, until you reach the sleeve cap.

49 Cast off as given for your size in the pattern using the method for decreasing several stitches (23 to 30) or for decreasing 1 stitch (33 to 34) as appropriate.

Once the shaping is complete, cast off the remaining stitches as given for the back.

## THE NECKBAND

Join the front and back together at one shoulder.

50 With the wrong side of the work facing you use the single eyelet tool to pick up the edge stitches at the neck onto the back bed of the machine. Your pattern will tell you exactly how many stitches to pick up on each section.

51 Bring all the needles to working position 2 so that all the stitches are behind the latches. Thread the machine and clip the yarn onto the right hand yarn clip.

Knit 1 row on the stitch size used for stocking stitch.

52 Using the double eyelet transfer tool, transfer the stitches onto the front bed as illustrated. Return the empty needles to non-working position. Join the front and back carriages and set the stitch size on both carriages to that given for the rib. Work the number of rows given for your size in the pattern.

53 Bring the needles in non-working position 0 on the back bed to working position 1. Using the double eyelet transfer tool, transfer the front bed stitches onto the empty needles.

Cast off loosely.

## MAKING UP

54 Follow the instructions given in your pattern.

# V NECK RAGLAN SLEEVE SWEATER

3

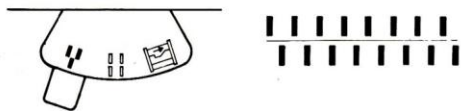

4

| NEEDLE BEDS | NEEDLES             |
|-------------|---------------------|
| BACK        | •     •     •       |
| FRONT       | •     •     •     • |

5

| CARRIAGES | KEY | STITCH | N.R.L.  | N.S.B. | MOVEMENT |
|-----------|-----|--------|---------|--------|----------|
| BACK      |     |        | ● ● ● ● |        | ←        |
| FRONT     |     |        | ● ● ● ● | ● . ●  | ←        |

7

|       |  |  |   |
|-------|--|--|---|
| BACK  |  |  | → |
| FRONT |  |  | ← |

## THE BACK

2 × 2 industrial rib.

## THE BACK

- 1 Set the space selector so that 4 is showing in the window.

Make sure that the intermediary lever is in the centre position and the flow combs are opposite each other.

The carriages are on the right.

- 2 Bring up all the needles given for your size in the pattern on both beds to working position 1.

- 3 Move the intermediary lever to the left and the racking lever to the right simultaneously. The needles are now alternate.

- 4 Return needles to non-working position so that the needle arrangement illustrated is achieved.

— = needle in working position 1.

• = needle in non-working position 0.

Set the carriage:

- 5 Press the knit key V down on both carriages. Set the stitch size dial on both carriages to 1. The needle returning levers are in the centre position.

The needle selection buttons are down.

Thread the machine.

Move the carriages to the left.

- 6 Insert the cast on comb and wire.

Place the small weights on the comb as close as possible to the last needle in working position at both ends of the comb.

- 7 Press the circular key on both carriages. Press the cancel key 0 on both carriages.

Set the stitch size dial to 3 on both carriages.

Knit 2 rows.

8

|           |   |
|-----------|---|
| BACK BED  | • |
| FRONT BED |   |

11



12



13

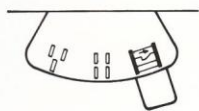

14

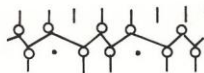

15

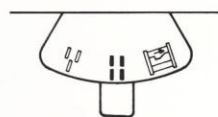

17



8 Move the racking lever one position to the left. The needles are now as illustrated.

9 Set the row counter to 000 and the stitch size dial to 4 on both carriages.

Knit the number of rows in rib given for your size in the pattern, ending with the carriages on the right.

### TRANSFERRING TO STOCKING STITCH

10 Increase the stitch size by one number on the front carriage.

Move the racking lever 1 position to the right.

11 Knit 1 row and move the carriages to the far left of the machine. The last row that you have knitted will look as illustrated.

12 Move the intermediary lever to the centre position and **at the same time** move the racking lever one position to the left. The flow combs are now opposite.

13 Move the intermediary lever to the right and then move the racking lever one position to the right.

14 Bring the needles in non-working position 0 on the back bed into working position 1. The needles are now as illustrated.

15 Transfer the stitches to the back bed using the transfer carriage. (See page 23).

Remove the transfer carriage from the machine.

Move the intermediary lever to the centre position and then move the racking lever one position to the left. The flow combs are now opposite.

16 Detach the front carriage by pressing on the coupling catch and move the front carriage to the left of the front bed out of the way. (See page 15.)

17 Set the row counter to 000.

Set the stitch size dial to 6 on the back carriage.

Move the space selector until 5 shows in the window.

Press the bed position levers towards the centre of the front bed and then push upwards so that the front bed moves to the upper position.

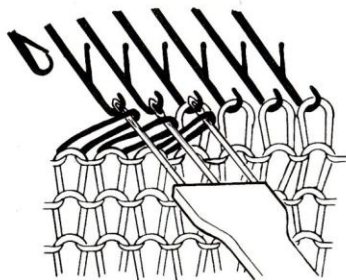

- 18 Knit the number of rows given for your size in the pattern to the armhole shaping.

#### ARMHOLE SHAPING - RAGLAN SLEEVE

- 19 Cast off the number of stitches given for your size in the pattern using the method given for casting off several stitches. See page 31.
- 20 Knit the number of rows given for your size in the pattern until the first decrease.

#### FULLY FASHIONED DECREASE

- 21 This type of decrease allows you to decrease on both sides of the knitting at the same time and adds a decorative and professional finish to your work.

- 22 Using the three eyelet transfer tool, move the three edge stitches one needle towards the centre. The third needle now has 2 stitches on it.

Lower the empty needle to non-working position 0.

- 23 Follow the pattern decreasing where necessary until the correct number of decreases have been worked.

- 24 Cast off loosely. See page 26.

#### THE FRONT

- 25 The front of the jumper is exactly the same as the back except for the neck shaping. Your pattern will tell you exactly which row to start the neck shaping for your size. Follow the pattern for the back until the neck shaping.

- 26 Bring all the needles left of 0 to holding position 3. Working on the needles right of centre only, continue to shape the raglan sleeve as given for the back **while at the same time** using the simple decrease method (see page 32) to shape the neck according to the pattern.

Use the claw weights at the neck edge, moving them up every 4-6 rows.

- 27 When the first side of the neck is complete bring all the empty needles down to non-working position 0.

- 28 Pull the yarn through the yarn mouth while the carriage is on the right of the machine.

Attach the end of the yarn to the left hand yarn clip and bring it under the needles in holding position 3.

29

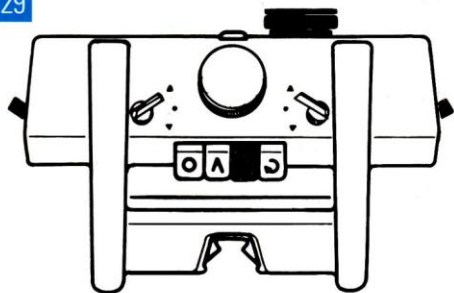

29 Move the needle returning levers to the lower position and take the carriages to the left. The needles have returned to working position 1 and a row has been knitted.

30 Knit the other side of the neck to match, reversing the shapings.

#### THE SLEEVES

31 Using the number of needles given for your size in the pattern, cast on the rib and transfer the stitches to the back bed, as given for the back.

32 Change to the main stitch size and using the fully fashioned increase method (see page 33) follow the pattern increasing where necessary until you reach the shoulder shaping.

33 Using the fully fashioned decrease method as given for the back (see page 37), follow the pattern for your size decreasing where necessary.

34 Cast off.  
Knit another sleeve the same.

#### THE NECKBAND

35 Join the shoulder seams (leaving the back right seam open) using an invisible seam (see page 28).

36 Pick up the number of stitches across the left front neck, left sleeve and back neck given for your size in the pattern onto the back bed. (See page 34.)

37 Knit the number of rows given for your size in the pattern using the main stitch size. Cast off loosely.

38 Using the same method, pick up the stitches on the other side of the neck and right sleeve and knit to match the first side of the neck.

#### MAKING UP

39 Follow the instructions given in your pattern.



# WAISTCOAT WITH PICOT EDGING AND POCKETS

2



3



4

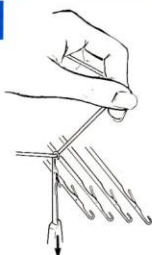

5

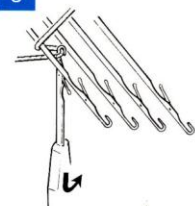

6

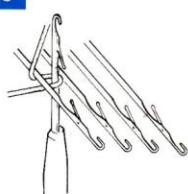

7

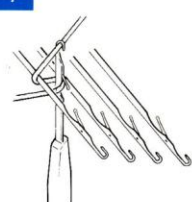

8



## THE POCKETS

Chain casting on.

- 1 Flow combs opposite.  
Release the front carriage and move it to the left.  
Space selector on 6.  
Row counter to 000.  
Carriage on the right.  
Knit (V) key pressed down on the back carriage.  
Stitch size 6.  
Needle returning levers in the lower position.
- 2 Bring up the number of needles given for the pockets for your size in the pattern to holding position 3.  
Lower the front bed and position the comb over the needles, as illustrated.
- 3 Thread the tension assembly but not the carriage.  
Clip the yarn into the left hand yarn clip, as illustrated.
- 4 Hold the yarn above the needles with your left hand.  
Catch it with the hook of the latch needle tool, as illustrated.
- 5 Pass the loop under the first left hand needle, as illustrated.
- 6 Bring it up between the first and second needle, as illustrated.
- 7 Let the loop slide behind the latch of the tool.  
Catch the yarn above the first needle, as illustrated.
- 8 Pull the tool downwards to form a **loose** stitch, as illustrated.

9

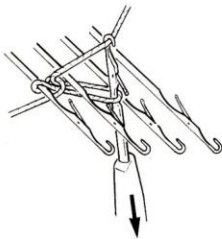

10

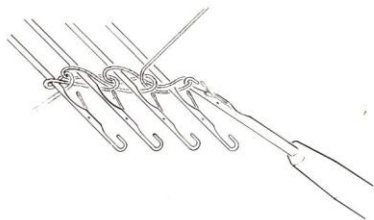

11

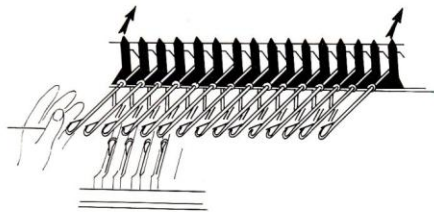

16

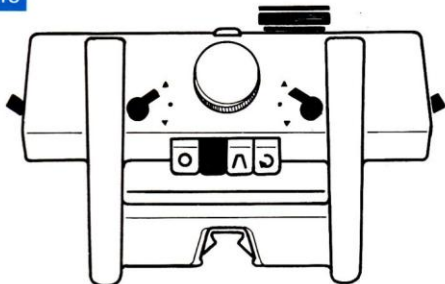

- 9 Pass the tool with the new stitch under the second needle and bring the tool up between the second and third needles, as illustrated.

Continue as above until the last but one needle.

- 10 Place the last loop on the last needle, as illustrated.

Bring the yarn under this needle and around to the carriage side.

Thread the carriage.

- 11 Return the front bed to working position. Lift the comb so that the wire is  $\frac{1}{2}$ " above the needles and tilt it so that the teeth are resting against the flow combs on the back bed, and the base of the comb rests against the front bed, as illustrated. The needles can move freely between the teeth of the comb.

- 12 Hold the comb firmly in position and move the carriage across the needles to the left.

- 13 Lower the comb and hang the 2 small weights on the comb as close as possible to the last needle in working position 1 on each side. Bring the needle returning levers to the centre position. Set the space selector indicator so that 4 is showing in the window.

Knit the number of rows given for your size in the pattern.

- 14 Thread a contrasting coloured waste yarn through the left hand side of the tension assembly.

Break off the main yarn and re-thread the carriage with the contrast yarn. Fasten it to the yarn clip.

Knit 6 rows.

Break off the contrast yarn and remove the work from the machine.

- 15 Work a second pocket to match.

#### THE BACK

#### The hem - open edge cast on

- 16 Flow combs opposite.

Space selector on 6.

Row counter to 000.

Release the front carriage and move it to the left.

Back carriage on the right - settings as illustrated.

Stitch size 6.

Thread the carriage.

17

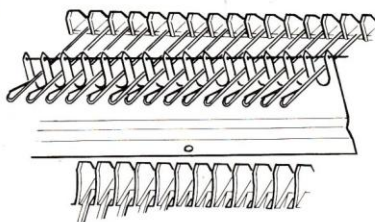

18

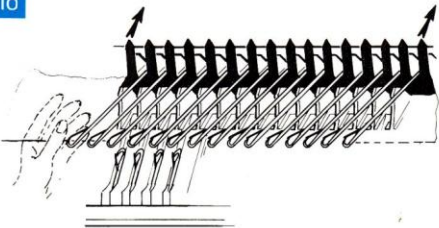

21

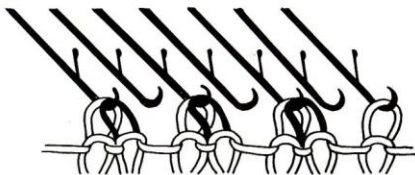

23

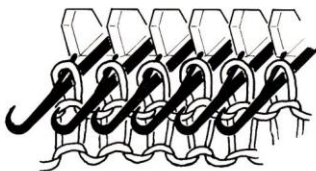

25

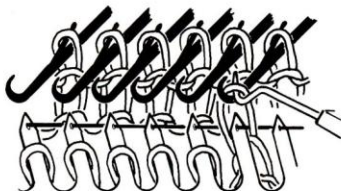

17 Bring the number of needles given for your size in the pattern to holding position 3 on the back bed. Lower the front bed and position the comb over the needles, as illustrated.

18 Return the front bed to working position. Lift the comb so that the wire is  $\frac{1}{2}$ " above the needles and tilt it so that the teeth are resting against the flow combs on the back bed and the base of the comb resting against the front bed, as illustrated. The needles can move freely between the teeth of the comb.

19 Hold the comb firmly in position and move the carriage across the needles to the left.

20 Lower the comb and hang the 2 small weights on the comb, as close as possible to the last needle in working position 1 on each side.

Bring the needle returning levers to the centre position.

Set the space selector indicator so that 4 is showing in the window.

Knit the number of rows given in the pattern to the picot edge.

21 Using the single eyelet tool, transfer the alternate stitches to the next needle on the left, as illustrated.

22 Bring the needles holding two stitches to working position 2. The empty needles are in working position 1.

Knit 1 row. A row of holes has now been made.

Knit the number of rows given in your pattern for your size.

23 Bring the needles forward so that they are mid-way between working positions 1 and 2, as illustrated. The stitches are resting on the latches.

24 Remove the weights from the comb and drop the front bed to intermediary position.

25 Lift the comb so that the wire is resting below the needles. Using the hook tool pick up the first loop from the comb onto the first right hand needle, as illustrated.

26

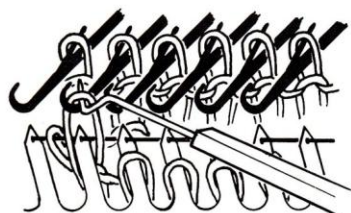

27

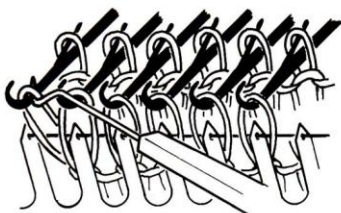

26 Lift the last loop on the left of the comb onto the last but one needle on the left, as illustrated.

27 Lift each loop from the comb onto its corresponding needle. Pick up the last loop on the left from the wire on the last working needle, as illustrated.

28 Bring all the needles to working position 2. Rehang the weights and return the front bed to working position.

Increase the stitch size by two numbers and knit 1 row.

29 Set the row counter to 000.

Set the stitch size dial to 6.

Follow the pattern for the back, shaping as necessary, until you reach the shoulder shapings.

### Shaping in holding position - part knitting

30 On the side opposite to the carriage, bring to holding position 3 the needles for the first row of the shoulder shaping less one needle.

Move the carriage across, all the needles will knit except those in holding position.

31 Move the last needle adjacent to those in holding position to holding position 3. This will prevent a hole forming. **At the same time** move the needles on the opposite side (again less one) to holding position 3 and knit. Bring the last adjacent needle to holding position 3.

32 Repeat this until all the needles required for the shoulder shapings are in holding position 3, placing claw weights as necessary.

33 When the shoulder shapings are complete, break off the main yarn and re-thread with a contrasting yarn.

34 Bring all the remaining needles in working position 1 to holding position 3.

35 Bring the needles for the right hand side of the shoulder shaping to working position 2.

Knit 6 rows.

Break off the yarn.

Remove these stitches from the needles and return the needles to non-working position 0.

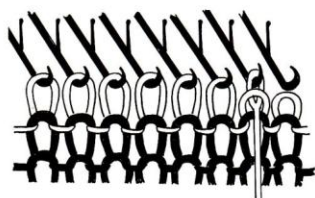

**36** Bring the needles for the back neck to working position 2 and using the method given above knit 6 rows in waste yarn.

**37** Repeat the above for the left hand side of the shoulder shaping.

#### THE RIGHT FRONT

**38** Cast on the number of stitches given for your size in the pattern and knit the hem as given for the back. (See page 40.)

Work as for the back until the row indicated in your size in the pattern for the pocket opening.

#### Pocket opening

**39** Clip a length of matching yarn to the right hand yarn clip.

Lower the front bed to the intermediary position.

Using the matching yarn and the cast off method given on page 31, cast off the number of stitches indicated in your size in the pattern for the pocket.

#### Picking up stitches from waste yarn

**40** With the wrong side of one of the pockets facing you, pick up the first row of loops in the main colour with the eyelet tool and place one on each empty needle, as illustrated.

**41** Hang the claw weights on the pocket and carefully pull the end of the waste yarn until it is removed from the pocket.

**42** Return the front bed to working position and knit according to your pattern, shaping as required.

#### Shoulder shaping

**43** Using the part row knitting given above 30 to 35 shape the shoulders and run the work off onto contrasting waste yarn.

**44** Work the left front to match, reversing the shapings.

#### Grafting

**45** Joining the shoulders.

47

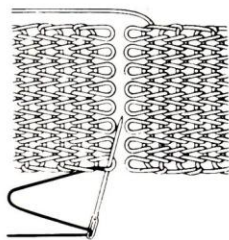

48

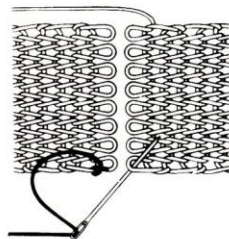

49

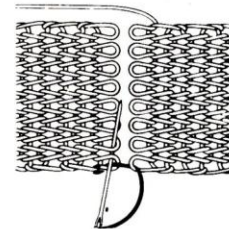

50

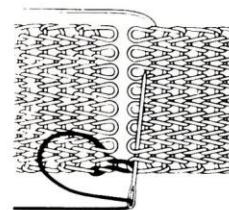

51

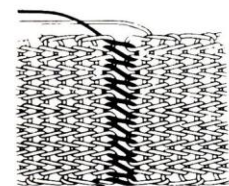

46 Grafting can be used to join open stitches, for example at the shoulders. It is a method of joining stitches by forming a row of stitches.

47 Place the needle with matching yarn through the edge stitch on the left.

48 Place the needle through the corresponding loop on the right.

49 Place the needle through the first and second stitches on the left to form a joining stitch.

50 Place the needle through the first and second stitches on the right to form a joining stitch.

51 Repeat steps 4 to 6 until all the stitches are joined.

59

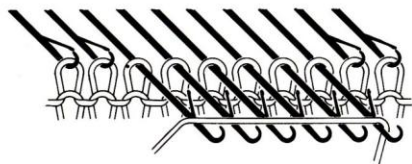

60

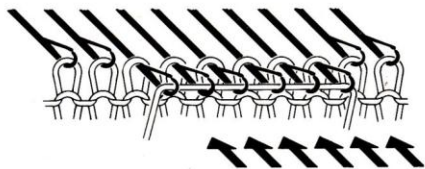

## Buttonband

- 52** With the wrong side of the left front facing you, use the single eyelet tool to pick up the number of stitches given for you size in the pattern onto the needles on the back bed.

Bring the needles to holding position 3.

Thread the carriage.

Set the stitch size to 7, press the knit V key down. Push the needle returning levers to the lower position.

Knit 1 row.

- 53** Move the needle returning levers to the centre position. Set the stitch size to 6. Knit the number of rows given in the pattern.

- 54** Make a picot edge. (See page 41.)

- 55** Knit the number of rows given in the pattern.

- 56** Cast off loosely. (See page 26.)

- 57** Pick up the stitches on waste yarn for the back neck. (See page 34.)

Work as above.

## Buttonhole band - horizontal buttonholes

- 58** Work as for the buttonband until the number of rows given for your size in the pattern have been knitted.

Placing buttonholes as indicated on the pattern, proceed for each buttonhole as follows:

- 59** Bring into working position 2 the number of needles stated in the pattern for a buttonhole. Place a piece of contrasting yarn into these needle hooks.

- 60** Lower the needles until the needle latches close. Pull down the needles individually by the heel to working position 1.

- 61** Work the number of rows remaining to the picot edge.

Make the picot edge.

**62** Work the number of rows given in your pattern.

Work buttonholes as on the same needles as before.

Work the number of rows stated in the pattern.

**63** Cast off loosely. Finish the buttonholes by backstitching through the stitches after removing the waste yarn.

**64** Picking up the number of stitches given in your pattern, work armband using the method given for the buttonband.

**65** Follow the instructions given in the pattern to finish the garment.



# FOR A MORE PROFESSIONAL TOUCH

## FINDING THE CORRECT STITCH SIZE DIAL SETTING FOR YOUR PATTERN

At the beginning of a pattern the number of rows and stitches measured over 10 cm is always given. To ensure that the garment comes out to the right size it is vital that you find the number on the stitch dial which will give this measurement.

Using the instructions for an open cast on (page ) cast on 60 stitches in the yarn you have chosen for your garment. The Freestyle patterns which have been created for your machine always give a suggested stitch size. Turn the stitch size dial to one whole number below this and knit 40 rows. Use a piece of different coloured waste yarn and knit two rows, then knit 40 rows on the suggested stitch size. Knit another 2 rows in the waste yarn and then knit 40 rows using one whole stitch size above the one suggested. Knit two rows in the waste yarn and remove the knitting from the machine.

Leave the knitting for at least 2 hours and preferably overnight to allow the yarn to go back to its natural shape. Lay the knitting on a flat surface and using a tape measure count the number of rows and stitches in 10 cm. Whichever stitch size gives you the correct measurement, this is the one you should use when knitting your garment.

1

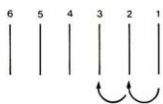

2

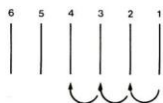

3

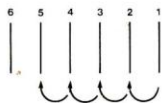

4

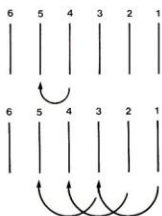

5

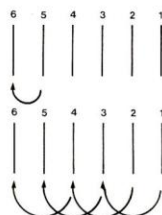

There are a number of ways of adding style to even a plain classically styled garment, simply by using a fancy decrease for example on a raglan sleeved sweater or cardigan.

The various methods given below have been selected by professional knitters. Each results in a neat edge to make the final assembly of a garment easier.

### Decreasing at the edges

#### 1 Single Italian Decrease. (1 stitch in.)

Transfer the stitches on needles 1 and 2 to needles 2 and 3.

Needle 2 holds 2 stitches after transferring.

#### 2 Single Italian Decrease. (2 stitches in.)

Transfer the stitches on needles 1, 2 and 3 to needles 2, 3 and 4.

Needle 4 holds 2 stitches after transferring.

#### 3 Single Italian Decrease. (3 stitches in.)

Transfer the stitches on needles 1, 2, 3 and 4 to needles 2, 3, 4 and 5.

Needle 5 holds 2 stitches after transferring.

#### 4 Double Italian Decrease. (2 stitches in.)

A. Transfer the stitch on needle 4 to needle 5.

B. Transfer the stitches on needles 1, 2 and 3 to needles 3, 4 and 5.

Needle 5 holds 3 stitches after transferring.

#### 5 Double Italian Decrease. (3 stitches in.)

A. Transfer the stitch on needle 5 to needle 6.

B. Transfer the stitches on needles 1, 2, 3 and 4 to needles 3, 4, 5 and 6.

Needle 6 holds 3 stitches after transferring.

6

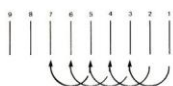

7

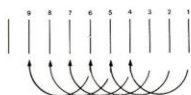

8

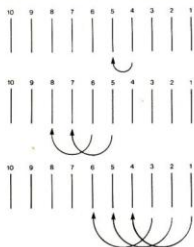

9

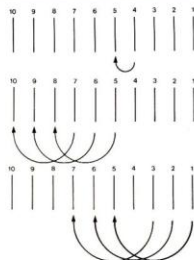

10

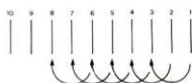

### 6 Fancy Double Italian Decrease. (3 stitches in.)

Transfer the stitches on needles 1, 2, 3, 4 and 5 to needles 3, 4, 5, 6 and 7.

Needles 6 and 7 hold 2 stitches after transferring.

### 7 Fancy Treble Italian Decrease.

Transfer the stitches on needles 1, 2, 3, 4, 5 and 6 to needles 4, 5, 6, 7, 8 and 9.

Needles 7, 8 and 9 hold 2 stitches after transferring.

### 8 Fancy Treble "Special Effect" Italian Decrease. (3 stitches in.)

A. Transfer the stitch on needle 4 to needle 5.

B. Transfer the stitches from needles 5 and 6 to needles 7 and 8.

C. Transfer the stitches from needles 1, 2 and 3 to needles 4, 5 and 6.

Needle 8 holds 2 stitches and needle 7 holds 3 stitches after transferring.

### 9 Fancy Quadruple "Special Effect" Italian Decrease. (3 stitches in.)

A. Transfer the stitch from needle 4 to needle 5.

B. Transfer the stitches from needles 5, 6 and 7 to needles 8, 9 and 10.

C. Transfer the stitches from needles 1, 2 and 3 to needles 5, 6 and 7.

Needles 9 and 10 hold 2 stitches and needle 8 holds 3 stitches after transferring.

### 10 Bias Decreasing.

Transfer stitches 1, 2, 3, 4, 5 and 6 to needles 3, 4, 5, 6, 7 and 8.

Return needle 1 to non-working position 0.

Needle 2 remains in working position 1.

Needles 7 and 8 hold 2 stitches after transferring.

1

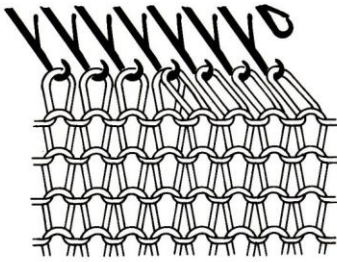

## DECREASING IN MID ROW

1

Decreasing 1 stitch.

Transfer the stitch onto the next needle.

Transfer all the stitches one needle in towards the centre.

Lower the empty needle to non-working position 0.

2

Decreasing Several Stitches

Knit several rows with contrasting waste yarn.

Remove the work from the machine.

Rehang the work onto the machine, placing 2 stitches on one needle as necessary.

1

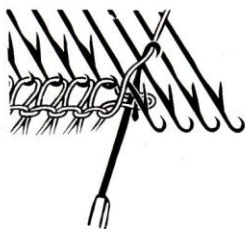

2



3



6



## INCREASING SEVERAL STITCHES

Chain cast on method.

Move the front bed to the lower position.

On the carriage side move the number of needles needed for the increase to holding position 3.

- 1 Remove the yarn from the feed mouth and hold it above the needles.

Insert the hook tool into the stitch on the last needle.

Bring the hook up between the first two empty needles so that the stitch slides behind the latch. Hook the yarn.

- 2 Pull the tool down so that the stitch pulls over the latch and the yarn forms a loose loop over the needle.

Move the hook tool to between the next two needles and repeat the procedure until the last needle is reached.

- 3 Place the last stitch on the hook tool onto the last needle.

Pass the yarn under the last needle and re-thread the carriage.

- 4 Hang a claw weight onto the new stitches. Return the front bed to working position. Set the needle returning levers to the lower position on the back carriage and knit.

Quick Increasing

- 5 Move the front bed to the lower position. On the carriage side move to the number of needles needed for the increase to holding position 3.

- 6 Pass the yarn under and over the empty needles making sure the yarn lays under the last needle, as illustrated.

- 7 Move the needles back to working position 2 and make sure the latches are open. Move the front bed to working position.

- 8 Knit 1 row. Lower the front bed and hang the edge weights on the new stitches.

Move the front bed to working position.

# BUTTONHOLES

5

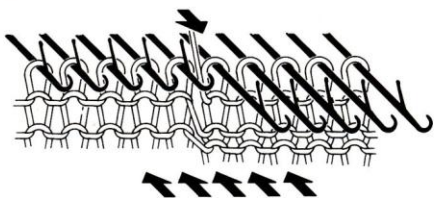

6

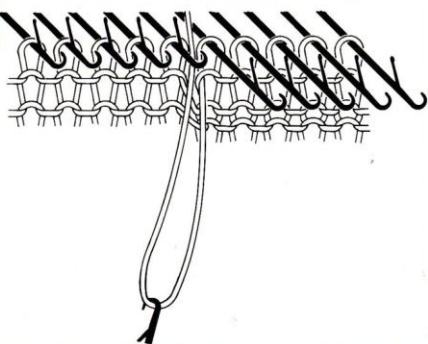

10

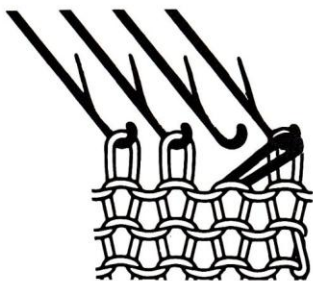

## STOCKING STITCH

### Vertical buttonholes

- 1 On the opposite side to the carriage move all the needles past the buttonhole position to holding position 3.
- 2 Hang a claw weight on the stitches which remain in working position 1. Knit the number of rows required for the buttonhole, ending with the carriage on the left.
- 3 Move the needles in working position 1 to holding position 3.
- 4 Move the carriage to the right so the yarn lays over the needles just worked.
- 5 Bring the needles opposite the carriage to working position 2, as illustrated.
- 6 Lower the front bed and hook the yarn between the two groups of needles and pull down several inches, as illustrated.
- 7 Move the front bed back to working position while holding the loop of yarn.
- 8 Knit the same number of rows as for the first side of the buttonhole, ending with the carriage on the left.
- 9 Bring the needles in holding position 3 to working position 2. Knit until the next buttonhole.
- 10 The loop of yarn is used to oversew the edge of the buttonhole so that it retains its shape.

### Round buttonholes - small buttons only

With the single eyelet tool transfer a stitch onto the adjacent needle.

Leave the empty needle in working position 1. It will knit on the next row thus forming the buttonhole.

### Horizontal buttonholes

See page 45.

1



2

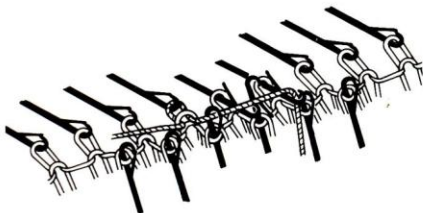

## RIB BUTTONHOLES

### Vertical buttonholes

See vertical buttonholes page 52.

### Round buttonholes

See round buttonholes page 52.

### Horizontal buttonholes

- 1 Bring the needles which form the buttonhole to working position 2 on both beds with the latches open.  
Lay a piece of contrast yarn across the needles, as illustrated.
- 2 Pull each needle in turn down to working position 1 so that the contrast yarn forms a new stitch, as illustrated.
- 3 Using the latch tool pull the ends of the waste yarn down between the beds so that they do not interfere with the knitting.
- 4 Continue knitting until the next buttonhole.
- 5 After finishing the work, carefully remove the waste yarn and back stitch through the open stitches to secure them with a matching yarn.

## Round neckbands - knitted separately

- 1 Cast on the number of stitches required for the neckband in rib.  
Work  $\frac{1}{3}$  number of rows required on rib tension  $-\frac{1}{2}$ .  
Work  $\frac{1}{3}$  number of rows required on rib tension.  
Work  $\frac{1}{3}$  number of rows required on rib tension  $+\frac{1}{3}$ .
- 2 Set the carriages to circular knitting.  
Bring up all the empty needles to working position 1. Set the stitch size to stocking stitch on both carriages.  
Work 4 or 5 rows circular (8 or 10 rows on the row counter).
- 3 Run work off onto waste yarn and remove from the machine.
- 4 Slide the neckline inside the circular knitted section and pin or baste into position.  
With the right side facing sew on the neckband using a backstitch in matching yarn. Do not tighten the stitches too much.  
On the wrong side slip stitch the band into position.  
Remove the waste yarn.

## Mitred neckband for V neck in rib - knitted separately

- 1 Cast on the number of stitches required for the neck using an open cast on the back bed in waste yarn.
- 2 Knit 1 row and manually transfer needles to the required rib setting.
- 3 Knit the required depth of the neckband, decreasing 1 stitch at each end on every row in rib in main yarn.
- 4 Knit the required depth again, increasing 1 stitch at each side on every row.
- 5 Run off onto waste yarn.
- 6 Sew the neckband onto the neckline on the outside, fold the neckband to the wrong side and slip stitch into position. Join the front at the "V" with an invisible seam.  
Remove the waste yarn.



1

|             |                               |
|-------------|-------------------------------|
| NEEDLE BEDS | NEEDLES                       |
| BACK        | •   •   •   •   •   •   •   • |
| FRONT       | .....                         |

2

|           |   |        |   |
|-----------|---|--------|---|
| CARRIAGES | KEY   | STITCH | N.R.L.  |
| BACK      |  | SIZE 6 |  |

4

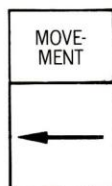

6

|       |       |
|-------|-------|
| BACK  |       |
| FRONT | ..... |

## CLOSED EDGE CAST ON

Back bed.

Set the bed space lever to 6.

- 1 Bring alternate needles to holding position 3.  
Hang the comb over the needles as for a hem (see page 41).
- 2 Set the back carriage as shown.
- 3 Thread the carriage.
- 4 Holding the comb as for a hem, see page 41.  
Move the carriage to the left.
- 5 Lower the comb and hang on the small weights.
- 6 Move the needles in non-working position to working position.
- 7 Return the needle returning levers to the centre position.
- 8 Knit 1 row.
- 9 Move the front bed to the upper position.

## Hand stocking stitch closed edge cast on

- 1 Cast on using an open cast on method (see page 41) in waste yarn. Knit several rows ending with the carriage on the right.
- 2 Thread the tension assembly with the main yarn, and fasten the end to the yarn clip on the left hand clamp.
- 3 Lower the front bed to intermediary position.
- 4 Move the first left hand needle to working position 2 so that the stitch slides behind the latch.
- 5 Pass the main yarn under the needle and back into the hook, then under the needle again.
- 6 Pull the needle back to working position 1 to form a loose stitch.
- 7 Repeat the above across all the needles.
- 8 Thread the yarn into the yarn mouth.  
Place the front bed in the upper position.  
Knit.
- 9 Remove the waste yarn at the end of the knitting.

1

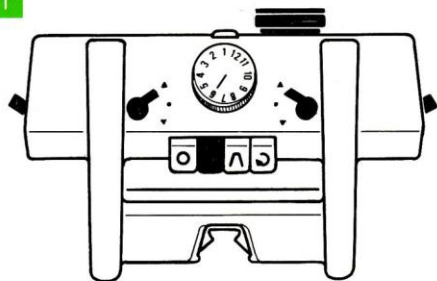

2

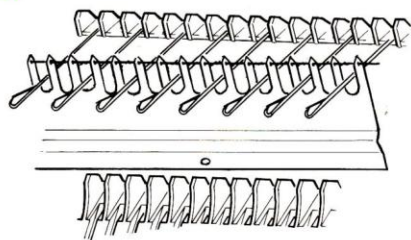

3

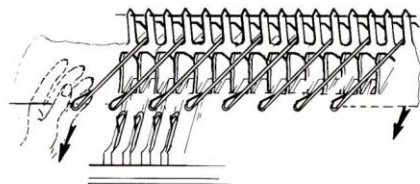

## RIB VARIATIONS

### Mock Ribs

While your machine is a true double bed machine and is therefore capable of producing a wide range of true ribs involving both knit and purl stitches, there are occasions in garment construction when a mock rib can be used effectively to complement the true ribs. For example, in the making of folded neckbands for sweaters.

#### 1 × 1 Mock Rib

- 1 Flow combs opposite.  
Release the front carriage and move it to the left.  
Bed space selector on 6.  
Row counter to 000.  
Carriage on right - settings as illustrated.  
Stitch size 6.  
Thread the carriage.
- 2 Bring the alternate needles on the back bed to holding position 3.  
Lower the front bed and position the comb over the needles, as illustrated.
- 3 Return the front bed to working position. Lift the comb so that the wire is  $\frac{1}{2}$ " above the needles and tilt it so that the teeth are resting against the flow combs on the back bed and the base of the comb rests against the front bed, as illustrated. The needles can move freely between the teeth of the comb.
- 4 Hold the comb firmly in position and move the carriage across the needles to the left.
- 5 Lower the comb and hang the 2 small weights on the comb.  
Bring the needle return levers to the centre position.  
Set the space selector so that 4 is showing in the window.
- 6 Knit the number of rows required for the depth of the hem.
- 7 Increase the stitch size by 2 numbers.  
Knit 1 row.
- 8 Decrease the stitch size by 2 numbers.  
Knit the same number of rows as in step 6.  
Knit 1 extra row.

10

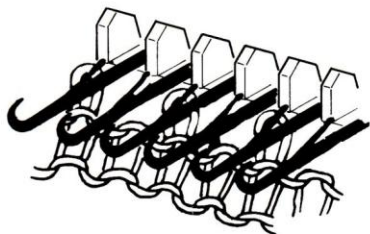

12

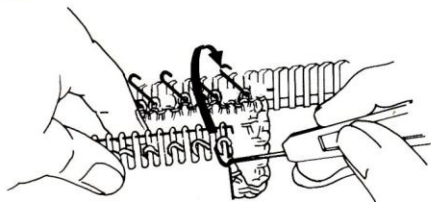

14



15



9 Bring the needles forward so that they are mid-way between working positions 1 and 2, as illustrated.

Remove the weights from the comb and drop the front bed to intermediary position.

10 Bring the needles in non-working position 0 to working position 1.

11 Lift the comb so that the wire is resting below the needles, as illustrated.

12 Lift each loop from the comb onto the corresponding empty needle.

13 Bring all the needles to working position 2. Rehang the weights and return the front bed to working position.

Increase the stitch size by 2 numbers for the next row only.

### 2 × 1 Mock Rib

14 Work as for 1 × 1 mock rib, using the needle settings illustrated.

### 3 × 1 Mock Rib

15 Work as for 1 × 1 mock rib using the needle settings illustrated.

2

|           |       |
|-----------|-------|
| CARRIAGE  |       |
| BACK BED  | ••••• |
| FRONT BED | ••••• |

3

| CARRIAGE | STITCH | STITCH SIZE | N.R.L. | N.S.B. |
|----------|--------|-------------|--------|--------|
| BACK     |        |             | •••••  |        |
| FRONT    |        |             | •••••  |        |

5

| CARRIAGE | STITCH | STITCH SIZE |
|----------|--------|-------------|
| BACK     |        |             |
| FRONT    |        |             |

6

| CARRIAGE | STITCH |
|----------|--------|
| BACK     |        |
| FRONT    |        |

2

| CARRIAGE | STITCH |
|----------|--------|
| BACK     |        |
| FRONT    |        |

2

|           |       |
|-----------|-------|
| BACK BED  | ••••• |
| FRONT BED | ••••• |

3

| CARRIAGE | STITCH | STITCH SIZE | N.R.L. | N.S.B. |
|----------|--------|-------------|--------|--------|
| BACK     |        |             | •••••  |        |
| FRONT    |        |             | •••••  |        |

## Single Sided Fisherman's Rib

- 1 Carriages on right of the bed.  
Intermediary lever to centre position.  
Flow combs and needles opposite.  
Space selector to 4.  
Front bed in working position.
- 2 Arrange the needles as illustrated.
- 3 Set the carriages as illustrated.  
Knit 1 row.
- 4 Place the comb and weights.
- 5 Set the carriages as illustrated.  
Knit 2 rows.
- 6 Set the carriages as illustrated and increase the stitch size to 6 on both carriages.
- 7 Knit the required number of rows.

## Double Sided Fisherman's Rib

- 1 Work steps 1-5 as for single sided Fisherman's Rib.
- 2 Set the carriages as illustrated and increase the stitch size to 7 on both carriages.
- 3 Knit the required number of rows.

## 2 × 2 Double Sided Fisherman's Rib

- 1 Carriages on right of bed.  
Intermediary lever to left.  
Flow combs and needles alternate.  
Space selector to 4.  
Front bed in working position.
- 2 Arrange the needles as illustrated.
- 3 Set the carriages as illustrated.  
Knit 1 row.

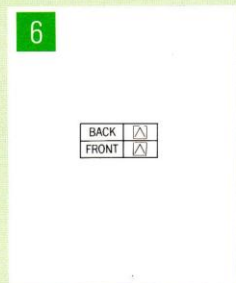
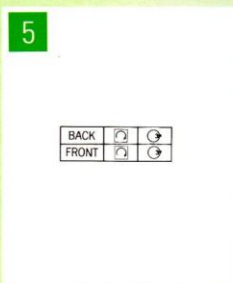
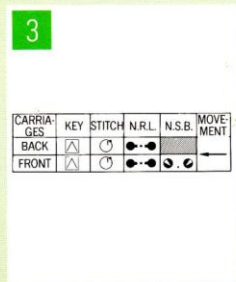

- 4 Place the comb and weights.
- 5 Set the carriages as illustrated. Knit 2 rows.
- 6 Move the intermediary lever to the centre and then move the racking lever 2 positions to the left so that the flow combs are opposite and the needles are as illustrated.
- 7 Set the carriages as illustrated and increase the stitch size to 6.
- 8 Knit the required number of rows.

**Close Rib.** (Full Needle Rib.)

**NB.** As all the needles are in use on both beds it is **not** suitable for heavy yarns.

- 1 Carriages on the right of the bed. Intermediary lever to the left. Flow combs and needles opposite. Space selector to 4. Front bed in working position.
- 2 Bring all the needles on both beds to working position 1 as illustrated.
- 3 Set the carriage as illustrated. Knit 1 row.
- 4 Place the comb and weights.
- 5 Set the carriages as illustrated. Knit 2 rows.
- 6 Set carriages as illustrated and set the stitch size dial on both carriages to stocking stitch size for the yarn less 2 whole numbers. Knit the required number of rows.

2

|       |  |
|-------|--|
| BACK  |  |
| FRONT |  |

2

|       |  |
|-------|--|
| BACK  |  |
| FRONT |  |

3

|       |  |
|-------|--|
| BACK  |  |
| FRONT |  |

2



1

|       |  |
|-------|--|
| BACK  |  |
| FRONT |  |

2

| CARRIAGES | KEY |
|-----------|-----|
| BACK      |     |
| FRONT     |     |

### Fancy Rib A

- 1 Work steps 1-5 of the Single Sided Fisherman's Rib instructions.
- 2 Set the carriages as illustrated.  
Increase the stitch size by 2-3 whole sizes on both carriages.  
Knit the required number of rows.

### Fancy Rib B

- 1 Work steps 1-5 of the Single Sided Fisherman's Rib instructions.
- 2 Using the double ended eyelet tool transfer the stitches from the front bed to the back bed to achieve the needle setting illustrated.
- 3 Set the carriages as illustrated.  
Increase the stitch size on the back bed to 6.  
Change the stitch size on the front carriage so that it is one number less than the size on the back bed.  
Knit the required number of rows.

### Fancy Rib C

- 1 Work steps 1-5 of the Single Sided Fisherman's Rib instructions.
- 2 Using the double eyelet tool transfer the stitches between the beds to achieve the needle setting illustrated.
- 3 Set the carriage to setting A and work 1 row.
- 4 Set the carriage to setting B and work 1 row.
- 5 Repeat steps 3 and 4 for the required number of rows.

### Fancy Rib D

Follow steps 1-5 of the Close Rib.

- 1 Transfer the stitches not required on the front bed to the back bed so that the needle arrangement illustrated is achieved.
- 2 Set the carriages as illustrated.  
Set the stitch size dial on both carriages to one suitable for stocking stitch in the yarn.  
Knit the required number of rows.

1

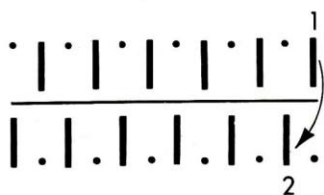

4

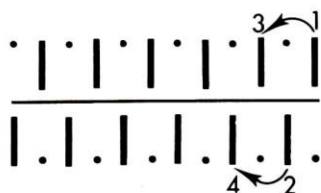

7

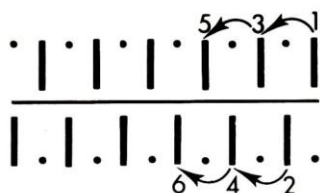

10

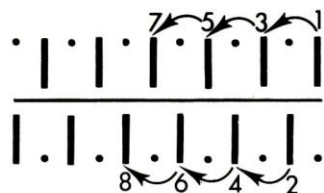

## DECREASING IN RIB

### Simple Decrease

- 1 Keeping the continuity of the needle arrangement, use the double ended eyelet tool to transfer the stitch on needle 1 to needle 2.
- 2 Move the needle with 2 stitches (needle 2) to working position 2.
- 3 Lower the empty needle and knit.

### Double Decrease

- 4 Move the stitch on needle 1 on the back bed to needle 3 as illustrated.  
Move the stitch on needle 2 on the front bed to needle 4 as illustrated.
- 5 Move needles 3 and 4, which have 2 stitches, to working position 2.
- 6 Move the empty needles to non-working position and knit.

### Italian Decrease

- 7 Move the stitches on needles 1 and 3 to needles 3 and 5 on the back bed as illustrated.  
Move the stitches on needles 2 and 4 to needles 4 and 6 on the front bed as illustrated.
- 8 Move needles 5 and 6 which have 2 stitches to working position 2.

- 9 Lower the empty needles to non-working position and knit.

### Double Italian Decrease

- 10 Move the stitches on needles 1, 3 and 5 to needles 3, 5 and 7 on the back bed as illustrated.  
Move the stitches on needles 2, 4 and 6 to needles 4, 6 and 8 on the front bed as illustrated.
- 11 Move needles 7 and 8 which have 2 stitches to working position 2.
- 12 Lower the empty needles to non-working position and knit.

1

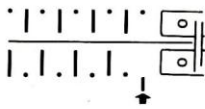

2



3



4

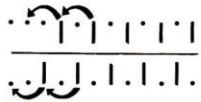

5



6

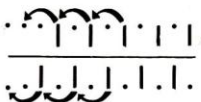

7



## INCREASING IN RIB

### Simple Increase

- 1 On the carriage side and maintaining the needle arrangement between the beds, move an empty needle to working position 1 as illustrated

### Simple Transferred Increase

- 2 Using the double ended eyelet tool, transfer the last stitch to the opposite bed maintaining the needle arrangement between the beds as illustrated.
- 3 Take the heel of the stitch adjacent to the new position of the transferred stitch and place it on the empty needle as illustrated.

### Italian Increase (2 stitches out)

- 4 Transfer the stitches on both beds as illustrated.
- 5 Pick up the heels of the stitches from the needles shown and transfer them to the empty needles as illustrated.

### Italian Increase (3 stitches out)

- 6 Transfer the stitches on both beds as illustrated.
- 7 Pick up the heels of the stitches from the needles shown and transfer them to the empty needles as illustrated.



# FANCY STITCH PATTERNS

1

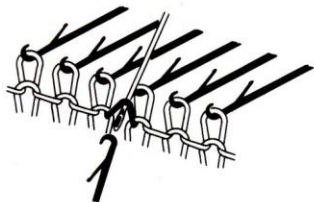

2

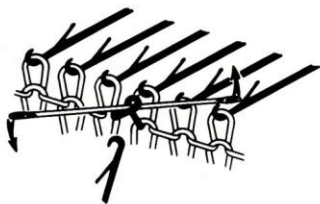

3

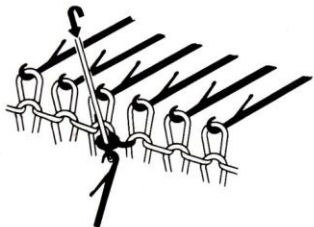

2

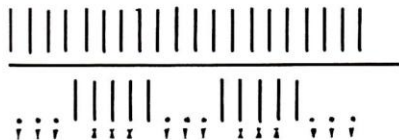

3

| CARRIAGES | KEYS | STITCH | N.R.L. | N.S.B. | MOVEMENT |
|-----------|------|--------|--------|--------|----------|
| BACK      |      |        |        |        |          |
| FRONT     |      |        |        |        |          |

An almost infinite variety of fancy stitch patterns can be created on your machine by utilising various needle settings on the two beds in conjunction with with different key settings on the carriages.

While many of the patterns given below can be achieved after knitting a rib, by manually transferring stitches to the given needle settings, there are some instances where it is necessary to start the work with a chain cast on. In such cases a rib can easily be added afterwards by hanging the chain cast on back onto the back bed, manually transferring the stitches to a rib setting and knitting the rib as normal.

1 There are times when in order to achieve the correct needle settings additional stitches are required. In this instance extra stitches can be made by using the double ended eyelet tool to pick up the loop between the two stitches on the opposite bed, as illustrated.

2 The double ended eyelet tool should be turned through 90 degrees to twist the loop, as illustrated.

3 Transfer the loop onto the needle, as illustrated.

## Fancy Stitch A

1 Suggested cast on method: Close rib. (See page 59.)

Use fine yarns - 2/3 ply.

Space selector set to 3.

Intermediary lever to the left - needles alternate.

2 Transfer stitches manually to obtain needle setting illustrated.

3 Set carriages as illustrated.

4 Knit 6 rows.

5 Bring needles marked X to working position 2 and return to non-working position 0 so that the stitches drop. Move the stitches marked Y to working position 1.

6 Knit 6 rows.

7 Bring needles marked Y to working position 2 and return to non-working position 0 so the stitches drop. Move the X needles to working position 1.

8 Repeat steps 4-7 as required.

2

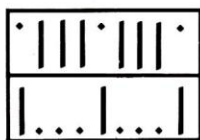

3

| CARRIAGES | KEYS | STITCH | N.R.L. | N.R.B. | MOVEMENT |
|-----------|------|--------|--------|--------|----------|
| BACK      |      |        |        |        |          |
| FRONT     |      |        |        |        |          |

5

| CARRIAGES | KEYS | STITCH | N.R.L. | N.R.B. | MOVEMENT |
|-----------|------|--------|--------|--------|----------|
| BACK      |      |        |        |        |          |
| FRONT     |      |        |        |        |          |

2

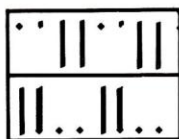

3

| CARRIAGES | KEYS | STITCH | N.R.L. | N.R.B. | MOVEMENT |
|-----------|------|--------|--------|--------|----------|
| BACK      |      |        |        |        |          |
| FRONT     |      |        |        |        |          |

## Fancy Stitch B

1 Suggested cast on method: 1 × 1 rib. (see page 20.)

Use fine yarn - 3/4 ply.

Space selector set to 3.

Intermediary lever to centre position - needles opposite.

2 Transfer stitches manually to obtain needle setting illustrated.

3 Set carriages as illustrated.

4 Knit 3 rows.

5 Set carriages as illustrated.

6 Knit 1 row.

7 Repeat steps 3-6 as required.

## Fancy Stitch Pattern 3

1 Suggested cast on method: 1 × 1 rib. (See page 20.)

Yarn - 3/4 ply.

Space selector set to 4.

Intermediary lever to centre position - needles opposite.

2 Transfer stitches manually to obtain needle setting illustrated.

3 Set carriages as illustrated.

4 Knit as required.

1

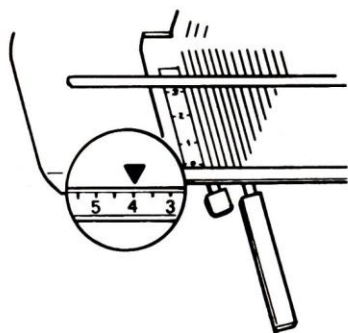

2

|       |            |
|-------|------------|
| BACK  |            |
| FRONT | ... ... .. |

3

|       |   |
|-------|---|
| BACK  | △ |
| FRONT | △ |

A variation of fancy stitch patterns are known as racking patterns. These combine various needle and carriage settings with the lateral movement of the front bed achieved by moving the racking lever either right or left as directed.

On all racking patterns the flow combs and needles are alternate at all times. For easy reference there is a scale numbered from 1-8 on the lower slide rail at the left. A triangular indicator is located on the left hand end cover and shows the position of the front bed in relation to the scale during knitting.

When the indicator is opposite a full number, as illustrated, the intermediary lever is at the left and the needles and flow combs are alternate.

As with the fancy patterns above, it is necessary to transfer stitches between the beds in order to achieve the correct needle settings for the pattern. In order to achieve the correct front bed position for the pattern, the bed, in some instances, must be moved as directed before casting on in order to achieve the desired pattern.

### Racking Pattern A

Before casting on move the racking lever three positions to the left.

Suggested cast on: Close Rib. (See page 59.)

- 1 Space selector to 4.  
Intermediary lever to left - needles alternate.  
Indicator opposite 7 on numbered scale.
- 2 Transfer stitches manually to obtain needle setting illustrated.
- 3 Set carriages as illustrated.
- 4 Move racking lever one position to left.  
Indicator opposite 8 on numbered scale.
- 5 Knit 1 row. Move racking lever 1 position to right.
- 6 Repeat step 5 until indicator is opposite 1 on numbered scale.
- 7 Knit 1 row. Move racking lever 1 position to left repeat this step until indicator is opposite 8 on numbered scale.
- 8 Repeat steps 5 and 6 for required number of rows.

3

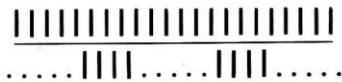

4

| CARRIAGES | KEYS | STITCH | N.R.L. | N.S.B. | MOVEMENT |
|-----------|------|--------|--------|--------|----------|
| BACK      |      |        |        |        |          |
| FRONT     |      |        |        |        |          |

3

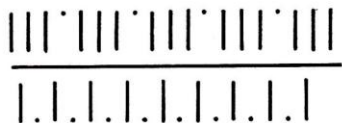

4

|       |  |  |
|-------|--|--|
| BACK  |  |  |
| FRONT |  |  |

### Racking Pattern B

- 1 Suggested cast on: Close Rib. (See page 59.)  
Yarn - 2/3 ply.
- 2 Space selector set to 5.  
Intermediary lever to left - needles alternate.  
Indicator opposite 4 on numbered scale.
- 3 Transfer stitches manually to obtain needle setting illustrated.
- 4 Set carriages as illustrated.
- 5 Knit 1 row.
- 6 Move racking lever 1 position to the right.
- 7 Knit 1 row.
- 8 Move racking lever 1 position to the left.
- 9 Repeat steps 5-8 for required number of rows.

### Racking Pattern C

- 1 Suggested cast on: Close Rib. (See page 59.)
- 2 Space selector set to 5.  
Intermediary lever to the left - needles alternate.  
Indicator opposite 4 on numbered scale.
- 3 Transfer stitches manually to obtain needle setting illustrated.
- 4 Set carriages as illustrated. Carriages at right.
- 5 Move racking lever 1 position to the left.
- 6 Knit 2 rows.
- 7 Move racking lever 1 position to the right.
- 8 Knit 2 rows.
- 9 Repeat steps 5-8 for required number of rows.

3

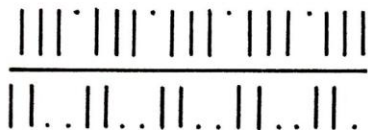

4

|       |  |
|-------|--|
| BACK  |  |
| FRONT |  |

3

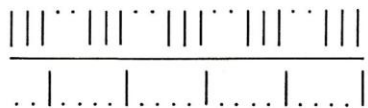

4

| CARRIAGES | KEYS | STITCH | N.B.B. | S.B.B. | MOVEMENT |
|-----------|------|--------|--------|--------|----------|
| BACK      |      |        |        |        |          |
| FRONT     |      |        |        |        |          |

## Racking Pattern D

- 1 Suggested cast on: Close Rib. (See page 59.)
- 2 Space selector set to 5.  
Intermediary lever to the left - needles alternate.  
Indicator opposite 4 on numbered scale.
- 3 Transfer stitches manually to obtain needle setting illustrated.
- 4 Set carriages as shown. Carriages at right.
- 5 Move racking lever 1 position to the right and knit 2 rows.
- 6 Repeat step 5 twice.
- 7 Move racking lever 1 position to the left and knit 2 rows.
- 8 Repeat step 7 twice.
- 9 Repeat steps 5-8 for the required number of rows.

## Racking Pattern E

- 1 Suggested cast on: either 1 × 1 rib or close rib.
- 2 Space selector set to 5.  
Intermediary lever to the left - needles alternate.  
Indicator opposite 4 on numbered scale.
- 3 Transfer stitches manually to obtain needle settings illustrated.
- 4 Set carriages as illustrated.
- 5 Move racking lever 1 position to the left and knit 1 row.
- 6 Repeat step 5 three times.
- 7 Move racking lever 1 position to the right and knit 1 row.
- 8 Repeat step 7 three times.
- 9 Repeat steps 5-8 for required number of rows.

3

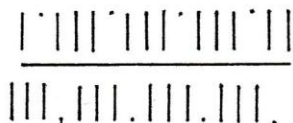

4

|       |  |  |
|-------|--|--|
| BACK  |  |  |
| FRONT |  |  |

3



4

|       |  |
|-------|--|
| BACK  |  |
| FRONT |  |

### Racking Pattern F

- 1 Suggested cast on: Close Rib. (See page 59.)
- 2 Space selector set to 5.  
Intermediary lever to the left - needles alternate.  
Indicator opposite 4 on numbered scale.
- 3 Transfer stitches manually to obtain needle settings illustrated.
- 4 Set carriages as illustrated.
- 5 Move racking lever 1 position to the right.
- 6 Knit 4 rows.
- 7 Move racking lever 1 position to the left.
- 8 Knit 4 rows.
- 9 Repeat steps 5-8 for required number of rows.

### Racking Pattern G

- 1 Suggested cast on: Close Rib. (See page 57.)
- 2 Space selector set to 5.  
Intermediary lever to the left - needles alternate.  
Indicator opposite 4 on numbered scale.
- 3 Transfer stitches manually to obtain needle settings illustrated.
- 4 Set carriages as illustrated. Carriages on right.
- 5 Knit 2 rows.
- 6 Move racking lever 1 position to the right.
- 7 Knit 2 rows.
- 8 Move racking lever 1 position to the left.
- 9 Repeat steps 5-8 for required number of rows.

# KNITTING WITH HEAVY YARN

1



2

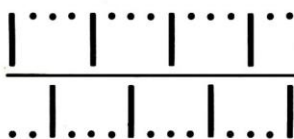

4

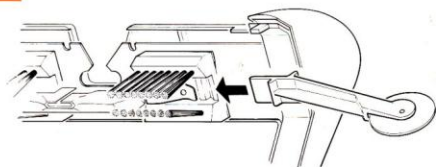

5 A.



5 B.

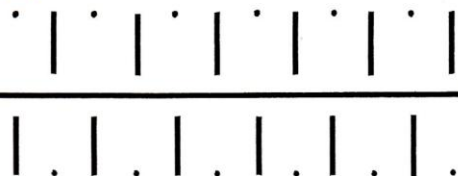

While most machines are capable of knitting fine yarn up to a 4 ply on every needle, yours can also knit a double knitting weight yarn on every needle. It can also knit heavier yarns either in rib or stocking stitch by using needles on both beds.

1

Cast on in stocking stitch.

Set the needles on the back bed as illustrated.

Set the space selector to 6.

Set the stitch size dial to 10.

Follow the instructions either for a closed edge cast on (see page 55) or an open cast on (see page 40).

2

Casting on in rib.

Set the needles on both beds as illustrated.

Set the space selector to 6.

Set the stitch size dial to 6.

Cast on as for 1 × 1 rib. (See page 20.)

3

Fisherman's ribs.

Follow the instructions for casting on in rib above.

**Single Sided Fisherman's:** Set stitch size dial to 8-11 (depending on thickness of yarn). Set carriage as shown for Single Sided Fisherman's Rib. (See page 58.)

**Double Sided Fisherman's:** Set stitch size dial to 9-12 (depending on thickness of yarn). Set carriage as shown for Double Sided Fisherman's Rib. (See page 58.)

4

To assist in the knitting of these ribs use the pushing down wheels which will help in stitch formation. These are fitted under the carriage, as illustrated.

5

Knitting in stocking stitch.

A. After casting on transfer all the stitches to the back bed so that the needle setting illustrated is obtained.

B. Bring up the needles on the front bed as illustrated.

C. Press the knit key on both carriages.

Set the stitch size to 3-4 on both carriages.

Knit 1 row.

D. Release the front carriage and pass it across the needles so that the stitches on the front bed drop.

E. Bring the front carriage across to the back carriage. Join them and knit 1 row.

F. Repeat steps 4 and 5 as required, gently pulling the knitting down every so often.

G. When the work is removed from the machine pull it several times so that it recovers its shape.



# CIRCULAR KNITTING

2

|           |  |
|-----------|--|
| BACK BED  |  |
| FRONT BED |  |

3

| CARRIAGES | STITCH | STITCH SIZE | N.R.L. | N.S.B. |
|-----------|--------|-------------|--------|--------|
| BACK      | △      | ⊙           | ●●●●   | ▨      |
| FRONT     | △      | ⊙           | ●●●●   | ●●●●   |

7

|           |  |
|-----------|--|
| BACK BED  |  |
| FRONT BED |  |

8

| CARRIAGES | STITCH |
|-----------|--------|
| BACK      | ⊙      |
| FRONT     | ⊙      |

4



Circular knitting can be used in the making of socks, seamless scarves and seamless sleeves. The carriages are set to knit the front and back bed needles independently rather than together as for ribs. As the carriage moves from right to left the needles on the front bed only are knitted; as the carriage moves from left to right the needles on the back bed only are knitted. One complete round of knitting is formed only after the carriages have moved across the bed twice, and the row counter registers 2 rows.



## Open cast on with auxiliary (waste) yarn.

- 1 Space selector set to 4.  
Intermediary lever to left - needles alternate.
- 2 Bring needles to working position 1 on both beds as illustrated.
- 3 Set carriages as illustrated. Carriages on right.
- 4 Knit 1 row in waste yarn.
- 5 Place comb and weights.
- 6 Break off waste yarn and thread carriage with main yarn and fasten it to the left hand yarn clip.
- 7 Set the intermediary lever to the centre position - flow combs opposite. Needles set as illustrated.
- 8 Set carriage as illustrated and knit required number of rows.
- 9 Remove waste yarn after securing stitches on completion of work.

## Closed Edge Cast On

- 1 Follow steps 1-6 of open cast on with auxiliary (waste) yarn above.
- 2 Thread the tension assembly but not the carriage with main yarn. Fasten the yarn to the left hand yarn clip.
- 3 Move the back bed needles to working position 2 so that the stitches slide behind the latches.
- 4 Pass the main yarn under the first needle and loop it back over the needle hook, as illustrated. Lower the needles to working position 1 to form a loose stitch.
- 5 Repeat step 4 across all the back bed needles.

8

| CARRIAGES | STITCH  | STITCH SIZE     |
|-----------|---|-----------------|
| BACK      |  | STOCKING STITCH |
| FRONT     |  | STOCKING STITCH |

9

|           |   |
|-----------|---|
| BACK BED  |  |
| FRONT BED |  |

6 Bring the front bed needles to working position 2 so that the stitches slide behind the latches.

7 Work across front needles as given for the back.

8 Thread the carriage and set it as illustrated.

9 Move the intermediary lever to the centre position - flow combs opposite. Needles set as illustrated.

10 Move the needles into working position 2 on the back bed. Knit 1 row.

11 Move the needles into working position 2 on the front bed. Knit 1 row.

12 Knit the required number of rows.

13 Remove waste yarn on completion of knitting.

### Semi-Circular Knitting

On some occasions the 180 needles on the back bed may not be enough to knit the width of fabric you require. A straight piece of fabric can be produced by using semi-circular knitting and, if required, all 360 needles can be used.

1 Follow steps 1-6 of open cast on with auxiliary (waste) yarn. (See page 71.)

2 Thread the machine with the main yarn.

3 Press the cancel key 0 on the back carriage and the knit key V on the front carriage. Knit 1 row. The carriages are now on the right.

4 Press the knit key V on the back carriage and the cancel 0 key on the front carriage. Knit 2 rows.

5 Press the cancel key 0 on the back carriage and the knit key V on the front carriage. Knit 2 rows.

6 Repeat steps 5 and 6 as required, ending with the carriages on the left for casting off.

# SOCK IN CIRCULAR KNITTING

3

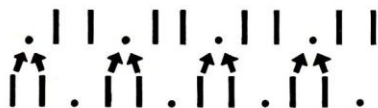

The pattern for the socks given below is designed to help you understand the techniques used in making socks. Once the techniques, such as shaping in holding position, have been learnt the basic pattern is easily adapted by using the chart at the end of this section so that you can knit socks in any size. We would suggest that you practice the techniques using the pattern given below.

## THE LEG

- 1 Cast on in  $2 \times 2$  industrial rib between needles 22 and 23 on each side of zero on the back bed.
- 2 Work 50 rows in rib, ending with carriages on the right.
- 3 Using the double ended eyelet tool, transfer the stitches manually to the empty needles, as illustrated.
- 4 Bring the intermediary lever to the centre. Release the front carriage.  
Place the front bed in upper position and set the space selector to 5.  
Set the stitch size to stocking stitch on the back carriage and depress the knit key.
- 5 Knit 1 row. At the side opposite to the carriage bring  $\frac{1}{4}$  ie. 12 needles, to holding position 3.
- 6 Knit 1 row. At the side opposite to the carriage bring  $\frac{1}{4}$  ie. 12 needles to holding position 3.
- 7 On the front bed move the needles opposite to those in working position 1 on the back bed to working position 1, and open the latches.
- 8 Lower the front bed to intermediary position.
- 9 Using the 20 eyelet transfer tool lift the stitches in holding position on the right on the back bed onto the tool. Replace the cover.
- 10 Drop the tool down between the beds. Turn the tool so that the last stitch on the right is now opposite the centre of the needles in working position 1 on the front bed.
- 11 Push the stitches down on the tool and carefully remove the cover. Hang the eyelets of the tool onto the needles on the front bed, placing the edge stitch on the centre needle. Transfer the stitches onto the needles.

- 12 Follow steps 9-11 for the needles in holding position on the left. The knitting is now formed into a circle. The centre needle on the front bed holds 2 stitches.
- 13 Break off the yarn and fasten it to the right hand stud. Lower the empty needles on the back bed to non-working position 0. Move the front bed back to normal working position.
- 14 Join the front and back carriages. Set the stitch size to stocking stitch and depress the circular knitting key on both carriages.
- 15 Work 10 rows in circular knitting. **NB.** This will be 20 rows on the row counter. Ending with the carriage on the right.

### THE HEEL

- 16 The heel is knitted on the front bed **only**. Press the cancel key on the back carriage and the knit key on the front carriage. Decrease the stitch size on the front carriage by one whole number.
- 17 Move the first needle on the right on the front bed to holding position 3. Knit 1 row.
- 18 Move the first needle on the left on the front bed to holding position 3. Knit 1 row.
- 19 Repeat steps 17 and 18 until  $\frac{1}{3}$ rd of the needles (7) are in holding position on each side of the front bed, ending with the carriage on the right.  
Use claw weights as required when knitting the heel.
- 20 At the opposite side to the carriage move the needle nearest the centre in holding position 3 to working position 2. Knit 1 row.
- 21 Lower the needle in holding position 3 nearest to the centre on the right to working position 2. Knit 1 row.
- 22 Follow steps 20 and 21 until only 1 needle in each group remains in holding position 3.
- 23 Lower both the needles to working position 2, place the yarn under the right hand needle and knit 1 row.
- 24 Set the carriages to circular knitting and the stitch sizes to stocking stitch.

### THE FOOT

- 25 Knit 25 rows in circular knitting. **NB.** This will be 50 rows on the row counter.

## THE TOE

- 26** With the double eyelet transfer tool transfer the 1st and 2nd stitches onto the 3rd and 4th needles at both ends on both beds. Lower the empty needles to non-working position 0.
- 27** Knit 2 rows circular. (4 rows on the row counter.)
- 28** Repeat steps 26 and 27 until 4 stitches remain on each bed.
- 29** Break the yarn and thread the end through one end of the double eyed transfer tool.
- 30** Lift one stitch from each bed alternatively from the needles and close the stitches by pulling up the end of the yarn and secure.
- 31** Join the ribbing using an invisible seam.

## Chart of sizes

The measurements may change according to the stitch size and to the thickness of the yarn.

|  |    |    |    |    |    |     |     |    |     |     |     |
|--|----|----|----|----|----|-----|-----|----|-----|-----|-----|
| Metric Sizes   | 15 | 18 | 21 | 24 | 27 | 30  | 33  | 36 | 39  | 42  | 45  |
| British Sizes  | 1  | 2½ | 4½ | 7  | 9½ | 11½ | 1   | 3½ | 5½  | 8   | 10½ |
| Figure on each side of 0 on the graduated scale for casting-on in 2/2 Industrial Rib         | 16 | 20 | 24 | 28 | 28 | 32  | 32  | 36 | 36  | 38  | 38  |
| Number of rows in 2/2 Industrial Rib for the leg   | 35 | 45 | 54 | 60 | 80 | 90  | 100 | 90 | 100 | 110 | 120 |
| Decreasing to be made for the ankle on the first circular row at equal distance, on each bed | 2  | 3  | 3  | 3  | 3  | 3   | 3   | 3  | 4   | 4   | 3   |
| Number of circular rows for the ankle (×2 on the row counter)                                | 5  | 5  | 5  | 8  | 8  | 8   | 12  | 12 | 16  | 16  | 16  |
| Number of circular rows for the foot (×2 on the row counter)                                 | 25 | 30 | 33 | 36 | 39 | 42  | 45  | 48 | 52  | 56  | 60  |
| Decreasing to be made every 2 circular rows (×2 on the row counter)                          | 3  | 4  | 4  | 5  | 5  | 6   | 6   | 6  | 6   | 7   | 7   |
| Number of remaining stitches to be taken on each end   | 3  | 3  | 3  | 3  | 3  | 3   | 5   | 5  | 5   | 5   | 5   |
| Length of the foot in cm according to the size   | 10 | 12 | 15 | 16 | 18 | 20  | 21  | 22 | 24  | 26  | 27  |

# WHAT TO DO IF...

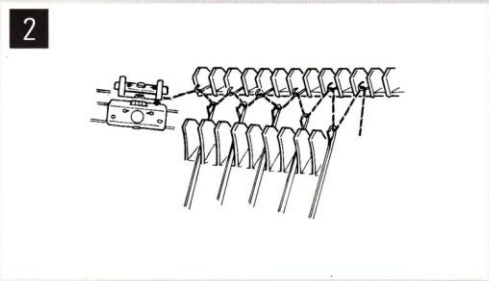
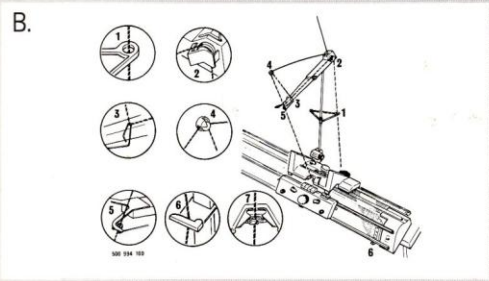
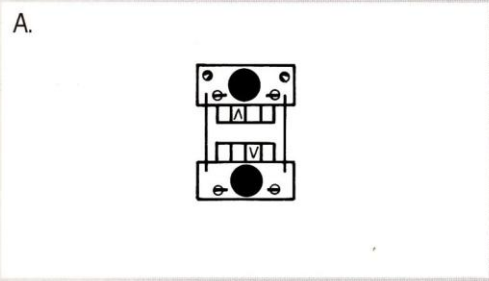
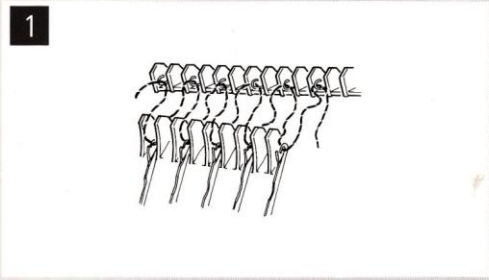

## PROBLEMS WITH CASTING ON

**1** The zig-zag row made for a rib before placing the comb and weights is loose or unevenly formed.

- A. Check the stitch size dial on both carriages is on 1.
- B. Check that the tension unit has been threaded correctly.

**2** The zig-zag row made for the rib before placing the comb and weights is tighter on the carriage side than the other side.

- A. Check that the yarn is running freely through the tension unit and is not caught up.
- B. Make sure you have not pushed the carriage too far passed the last needle in working position 1.
- C. Pull the butts of the needles down to pull more yarn through.

**3** One or several needles has not caught the yarn on the zig-zag row.

- A. Use the double eyelet tool to pick up the loop opposite the empty needle as shown.
- B. Check that the needles are undamaged, particularly the latches. If a needle or latch is damaged replace the needle. (See page 82.)

4 A



4 B

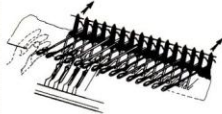

4 The carriage jams when casting on for a hem.

A. Check that the needles have not caught in the wire of the comb.

B. Check that the comb is raised above the needles and the teeth of the comb are resting against the flow combs, as illustrated.

C. Check that the stitch size is on 6.

1

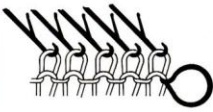

1 B

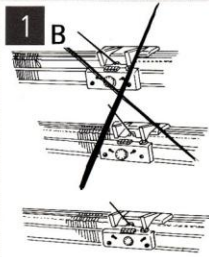

1 Loops are forming at the edges.

A. Check the tension unit is threaded correctly, and that the yarn has not slipped out of one of the guides.

B. Make sure that you are not going too far past the last needle on each side in working position.

Going past too far pulls excess yarn through which is not taken up by the span wires and so loops can be formed at the edges.

2

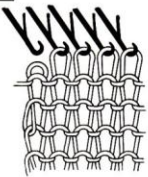

2 C

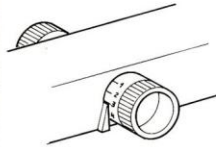

2 The edge stitches are dropping.

A. Check that the front bed is in the correct position for the stitch you are using. (See page 13.)

B. Check that the bed space is correct. (See page 13.)

C. Check that the tension unit is correctly set for the type of yarn you are using. (See page 8.)

D. Check that the weights have not reached the floor. If they have see page 81.

E. Make sure the edge weights are being moved up every few rows. (See page 33.)

F. Check the stitch size is correct for your yarn, it must be large enough to allow the needles to move freely, but if it is too large the stitches may slip out of the needle hooks. (See page 14.)

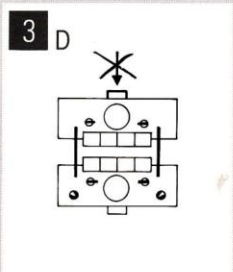
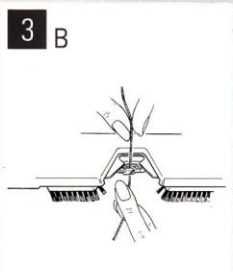

- 3** Your knitting drops off the machine.
- A. Check that you have not run out of yarn or that it has not broken.
  - B. Check the yarn has not come out of the yarn mouth.
  - C. Check that there are no knots in the yarn.
  - D. Check that the jacquard key is not depressed.

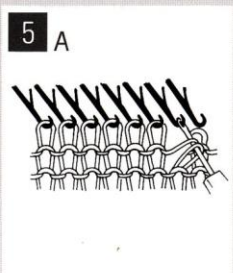
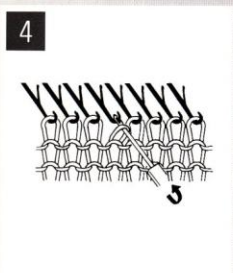

- 4** You need to replace the stitches on the needles.
- A. Use the single eyelet look to replace the stitches on the needles, as illustrated.

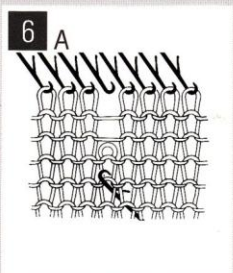
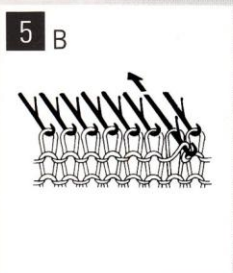

- 5** A stitch drops one row or is not knitted.
- A. Rehang the stitch and the unknitted yarn onto the needle.
  - B. Bring the needle forward to working position 2 so that the stitch falls behind the latch and place the unknitted yarn in the hook.

Pull the needle down by the butt to working position 1 so that a new stitch is formed.

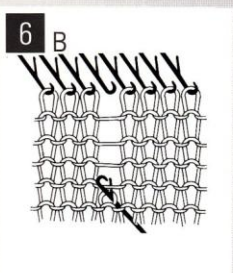

- 6** A stitch drops several rows.
- A. Insert the latch needle tool a few rows under the dropped stitch from the back of the knitting.
  - B. Push the tool upwards until the stitch drops behind the latch.
- Take the yarn from the row above into the hook of the tool.



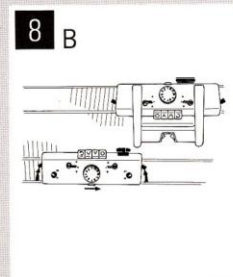
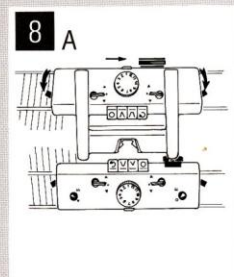
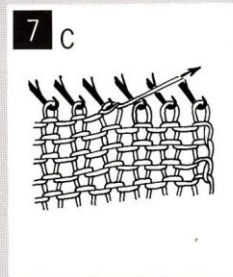
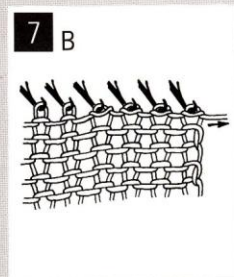
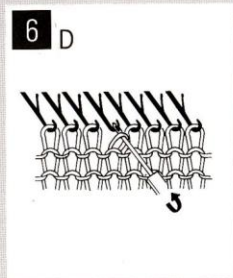
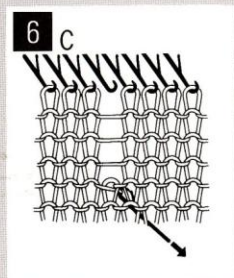

C. Pull the tool downwards until the latch closes and a new stitch is formed.

D. When the last loop of yarn has been knitted, transfer the stitch onto the needle with the single eyelet tool.

**7** You need to undo one or several rows.

A. Remove some of the weights from the knitting.

B. Pull the yarn to the side to tighten a few stitches at a time.

C. Pull the yarn up and over the needles one at a time - the stitch from the previous row will slip onto the needle hook.

D. Remember to re-set your row counter to the correct row.

**8** The carriages jam.

A. Start with the back carriage.

Move the locking levers upwards.

B. Lift the carriage back away from the bed.

Keeping the carriage clear of the needles slide it towards the beginning of the last row.

C. Once clear of the knitting replace the bed on the needle slide rails and release the locking levers. Check that it is firmly positioned on the rails.

D. Repeat this with the front carriage if necessary.

10

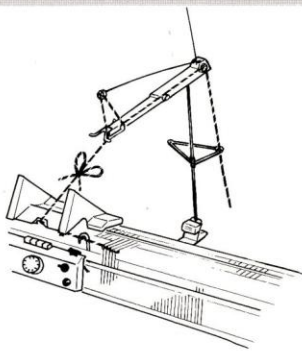

10 A

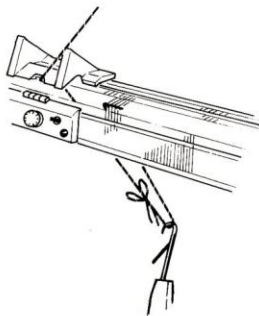

10 B

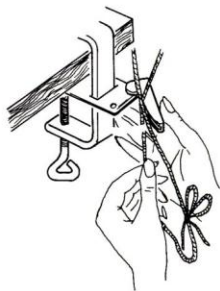

9 The carriage is hard to push.

A. Make sure the machine is clean and lubricated. (See page 82.)

B. Make sure there are no broken needles or bent latches. (See page 82.)

C. Check that the stitch size and bed space are correct for the yarn you are using.

10 There is a knot in the yarn.

A. Push the hook tool up between the beds and catch the yarn. Pull it down between the beds.

B. Fasten the yarn with the knot onto the yarn clip and continue knitting.

11

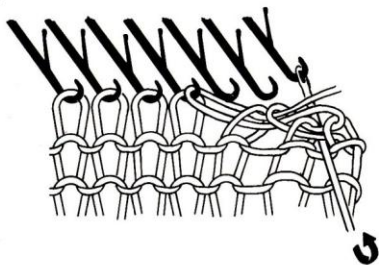

11

The decrease/cast off is too tight.

A. After casting off the first two stitches rehang the first stitch onto an empty needle as illustrated.

B. Hang every 5th stitch decreased back onto the bed in a similar fashion.

C. Once the decrease is complete remove all the stitches which have been re-hung from the machine, and return the needles to non-working position 0.

12

The weights reach the floor.

A. Move the needles up so that the stitches are laying on the latches.

B. Remove the weights.

C. Wrap the knitting around the comb.

D. Rehang the weights from the back at each side of the comb, as illustrated.

12

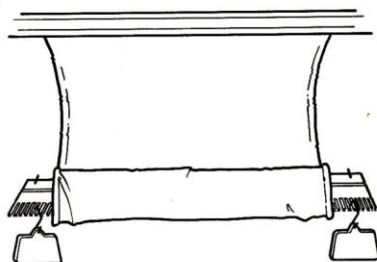

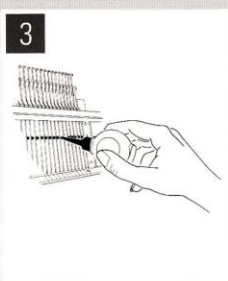
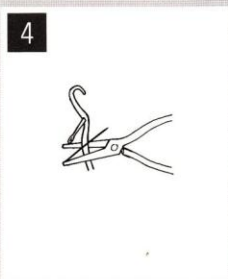
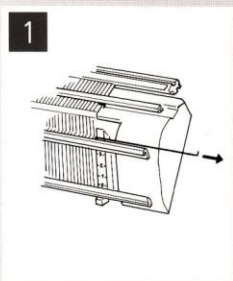

## A NEEDLE IS BENT OR BROKEN

**1** The needles are held in place by a rod. It has a bent end at the right hand side under the needle slide rail.

With the hook of the latch tool needle tool, pull the bent end of the rod until it clears the needle to be changed, as illustrated.

**2** Move the needle to working position 1. Close the hook to prevent it catching the needle retaining spring located under the rail.

Lift the needle by the heel with the hook tool towards the back, as illustrated, and remove it from the bed as illustrated.

**3** If the latch will not close or the hook is badly twisted, the needle head must be cut off with wire cutters as illustrated before the needle is removed.

**4** To replace a needle open the latch and slide it under the needle rail as illustrated.

**5** Push the rod back into place (bent end to the top) to lock all the needles in place.

## CLEANING YOUR MACHINE

Knitting machines need regular care and maintenance. Fluff and dust from yarn will form a deposit in the needle grooves and carriages, and this must be removed to allow the machine to function correctly.

**1** Using the cleaning brush provided brush the needle grooves and needles using an upward motion.

**2** Remove the carriages from the beds and brush them gently to remove fluff from the cams.

**3** Replace the carriages on the machine and bring all the needles on the front bed to working position 2. Place a small amount of fine oil on a clean cloth and wipe it across the heel of the needles.

**4** Move the front carriage to and fro to lubricate the carriage.

**5** Move the needles on the front bed to non-working position 0. Repeat steps 4 and 5 on the back bed.

# INDEX

- A**  
 Armholes  
   Raglan Sleeve 36  
   Set In Sleeve 31
- B**  
 Bed Positions  
   Needles Alternate 13  
   Needles Opposite 13  
   Quarter Pitch Position 13  
 Bed Positioning Levers  
   Description 1  
   Movement 8  
 Bed Space Selector  
   Description 1  
   Setting 13  
 Bent/Broken Needles 82  
 Button Holes  
   Horizontal 45  
   Horizontal in Rib 53  
   Round 52  
   Round in Rib 52  
   Vertical 52  
   Vertical in Rib 52  
 Button Bands 45
- C**  
 Cancel/Slip Key  
   Description and Use 16  
 Carriage Jamming 77, 79  
 Casting Off 26  
 Casting Off Several Stitches 31  
 Casting On  
   Chain 39  
   Closed Edge 55  
   Open Edge 40  
 Chain Cast On 39  
 Circular Knitting Key  
   Description and Use 15  
 Circular Knitting  
   Closed Edge Cast On 71  
   Open Edge Cast On 71  
 Claw weights  
   Description 3  
   Use 33  
 Cleaning Brush 5  
 Cleaning and Care of your machine 82  
 Closed Edge Cast On 55  
 Close Rib 59  
 Comb Placement 22  
 Comb Wire 22  
 Coupling Catch  
   Description 1  
   Use 15, 31
- D**  
 Decreasing Fancy 48  
 Decreasing in Mid Row 50
- Decreasing in Rib 61  
 Decreasing One Stitch 32  
 Description  
   Carriages 1  
   Main Parts 1  
   Needle Parts 14  
 Double Eyelet Tool  
   Description 2  
   Use 25
- E**  
 Edge Stitches Dropping 77
- F**  
 Fancy Rib 60  
 Fancy Stitch Patterns 63  
 Fishermans Rib  
   Single Sided 58  
   Double Sided 58  
   2×2 Double Sided 58  
 Front Bed  
   Description of 1  
   Intermediate Position 11  
   Lower Position 12  
   Positioning Of 8  
   Upper Position 11  
   Working Position 11  
 Fully Fashioned Decrease 36
- G**  
 Grafting 44
- H**  
 Heavy Yarn Wheel 5  
 Hem 40  
 Hook and Latch Needle Tool  
   Description 2  
   Use 26, 41  
 How a Stitch Is Made 14  
 How to Set up Your Machine 6-10
- I**  
 Increasing  
   Chain Cast On 51  
   Fully Fashioned 33  
   Quick 51  
 Intermediary Lever  
   Description 1  
   Movement 13  
 Invisible Seaming 28
- J**  
 Jacquard claw 5
- K**  
 Knit Key  
   Description and Use 16  
 Knitting with Heavy Yarn 69  
 Knots in Yarn 80

|                                      |            |  |        |
|--------------------------------------|------------|--|--------|
| <b>L</b>                             |            |  |        |
| Latch Brushes                        |            |  | 12     |
| Description and Use                  | 16         |  | 13     |
| Locking Levers                       |            |  | 7      |
| Description                          | 1          |  | 15     |
| Use                                  | 15         |  | 15     |
| Loops Forming at Edge of Knitting    | 77         |  |        |
| <b>M</b>                             |            |  |        |
| Mock Ribs                            |            |  |        |
| 1 × 1                                | 56         |  | 5      |
| 2 × 1                                | 57         |  | 72     |
| 3 × 1                                | 57         |  | 42     |
| Moving The Carriage                  | 21         |  | 27     |
| <b>N</b>                             |            |  |        |
| Neck Bands                           |            |  |        |
| Mitred V Neck Knitted Separate       | 54         |  |        |
| Round Neck Knitted Separate          | 54         |  |        |
| Round Neck Picked Up                 | 34         |  |        |
| V Neck Picked Up                     | 38         |  |        |
| Needle Description                   | 2          |  |        |
| Needle Parts                         | 14         |  |        |
| Needle Positions                     | 14         |  |        |
| Needle Return Levers                 |            |  |        |
| Description                          | 1          |  |        |
| Use                                  | 16, 33, 38 |  |        |
| Needle Rule                          |            |  |        |
| Description                          | 2          |  |        |
| Use                                  | 20         |  |        |
| Needle Selection Buttons             |            |  |        |
| Description                          | 1          |  |        |
| Use                                  | 16         |  |        |
| Needle Selector Tool 1 × 1 and 2 × 1 |            |  |        |
| Description                          | 2          |  |        |
| Use                                  | 20         |  |        |
| Needles Alternate                    | 13         |  |        |
| Needles Opposite                     | 13         |  |        |
| <b>O</b>                             |            |  |        |
| Oil                                  | 5          |  |        |
| Open Edge Cast On                    | 40         |  |        |
| <b>P</b>                             |            |  |        |
| Part Knitting                        | 42         |  |        |
| Picking up a dropped stitch          | 78         |  |        |
| Picking up stitches                  | 34         |  |        |
| Picking up stitches from waste yarn  | 43         |  |        |
| Picot Edge                           | 41         |  |        |
| Pocket Opening (Horizontal)          | 43         |  |        |
| Pockets                              | 39         |  |        |
| Problems with Casting On             | 76         |  |        |
| <b>Q</b>                             |            |  |        |
| Quarter Pitch Position               | 13         |  |        |
| <b>R</b>                             |            |  |        |
| Racking Lever                        |            |  |        |
| Description                          | 1          |  |        |
| Movement                             | 6, 12      |  |        |
|                                      |            | Storage                                  | 12     |
|                                      |            | Use with Intermedial Lever               | 13     |
|                                      |            | Working Position                         | 7      |
|                                      |            | Removing the Carriages                   | 15     |
|                                      |            | Replacing the Carriages                  | 15     |
|                                      |            | Row Counter                              |        |
|                                      |            | Description                              | 1      |
|                                      |            | Setting                                  | 10     |
|                                      |            | <b>S</b>                                 |        |
|                                      |            | Second Colour Guide                      | 5      |
|                                      |            | Semi-Circular Knitting                   | 72     |
|                                      |            | Shaping in Holding Position              | 42     |
|                                      |            | Simple Increase                          | 27     |
|                                      |            | Single and Double Eyelet Transfer Tool   |        |
|                                      |            | Description                              | 2      |
|                                      |            | Use                                      | 31, 33 |
|                                      |            | Slip/Cancel Key                          |        |
|                                      |            | Description and Use                      | 16     |
|                                      |            | Socks                                    | 73     |
|                                      |            | Space Selector                           |        |
|                                      |            | Description                              | 1      |
|                                      |            | Setting                                  | 13     |
|                                      |            | Stitch Size Dial                         |        |
|                                      |            | Description                              | 1      |
|                                      |            | Use                                      | 17     |
|                                      |            | Stitches Not Knitting                    | 78     |
|                                      |            | Stocking Stitch                          | 24     |
|                                      |            | <b>T</b>                                 |        |
|                                      |            | Table Clamps                             |        |
|                                      |            | Description                              | 3      |
|                                      |            | Fitting                                  | 6      |
|                                      |            | Tension Rod                              |        |
|                                      |            | Description                              | 4      |
|                                      |            | Fitting                                  | 9      |
|                                      |            | Tension Squares                          | 47     |
|                                      |            | Tension Unit                             |        |
|                                      |            | Description                              | 3      |
|                                      |            | Fitting                                  | 9      |
|                                      |            | Threading                                | 18     |
|                                      |            | Tension Unit Stand and Row Counter       |        |
|                                      |            | Description                              | 4      |
|                                      |            | Fitting                                  | 8      |
|                                      |            | Tension Wheel                            |        |
|                                      |            | Description and Use                      | 8      |
|                                      |            | Thread Guide                             |        |
|                                      |            | Description                              | 4      |
|                                      |            | Fitting                                  | 9      |
|                                      |            | Threading                                | 18     |
|                                      |            | Threading The Machine                    | 18     |
|                                      |            | Three Eyelet Transfer Tool               |        |
|                                      |            | Description                              | 2      |
|                                      |            | Use                                      | 36     |
|                                      |            | Transfer Carriage                        |        |
|                                      |            | Description                              | 4      |
|                                      |            | Use                                      | 23     |
|                                      |            | Transferring from stocking stitch to rib | 25     |

|                                      |    |
|--------------------------------------|----|
| Transferring to stocking stitch from |    |
| 1 × 1 rib                            | 23 |
| 2 × 2 industrial rib                 | 36 |
| 2 × 2 simple rib                     | 30 |

|                             |    |
|-----------------------------|----|
| Tuck Key                    |    |
| Description and Use         | 15 |
| Twenty Eyelet Transfer Tool | 2  |

## U

|              |    |
|--------------|----|
| Undoing Rows | 79 |
|--------------|----|

## W

|                                   |       |
|-----------------------------------|-------|
| Weaving Brush                     | 5     |
| Weights on Floor                  | 81    |
| Weights Large and Small           |       |
| Description                       | 3     |
| Use                               | 22    |
| What to do if ...                 |       |
| Bent/Broken Needles               | 82    |
| Carriage Jamming                  | 77,79 |
| Cleaning and Care of Machine      | 82    |
| Edge Stitches Dropping            | 77    |
| Knots in Yarn                     | 80    |
| Loops forming at edge of knitting | 77    |
| Picking up a stitch               | 78    |
| Problems with casting on          | 76    |
| Stitches not knitting             | 78    |
| Undoing Rows                      | 79    |
| Weights on Floor                  | 81    |

## Y

|                                    |        |
|------------------------------------|--------|
| Yarn Clip                          |        |
| Description                        | 3      |
| Use                                | 19     |
| Yarn Holder                        | 18     |
| Yarn Mouth                         |        |
| Description                        | 1      |
| Threading                          | 19     |
| 1, 2, 3 ...                        |        |
| 1 × 1 Mock Rib                     | 56     |
| 1 × 1 Needle Selector              |        |
| Description                        | 2      |
| Use                                | 20     |
| 1 × 1 Rib                          | 20-22  |
| 2 × 1 Eyelet Transfer Tool         |        |
| Description                        | 2      |
| Use                                | 31, 33 |
| 2 × 1 Mock Rib                     | 57     |
| 2 × 1 Needle Selector Tool         |        |
| Description                        | 2      |
| Use                                | 20     |
| 2 × 2 Double Sided Fisherman's Rib | 58     |
| 2 × 2 Industrial Rib               | 35     |
| 2 × 2 Simple Rib                   | 29     |
| 3 Eyelet Transfer Tool             |        |
| Description                        | 2      |
| Use                                | 36     |
| 3 × 1 Mock Rib                     | 57     |
| 20 Eyelet Transfer Tool            | 2      |

**SINGER<sup>\*</sup>**  
**We make it better.**

S.D.L. Limited, Grafton Way, Basingstoke, Hampshire. Tel: 0256 56291

Designed and Produced by SIMPSON · MAHONEY · PARROCK, Tunbridge Wells, Kent.

\*A Trademark of THE SINGER COMPANY