

INSTRUCTION MANUAL

MODEL

KH-230

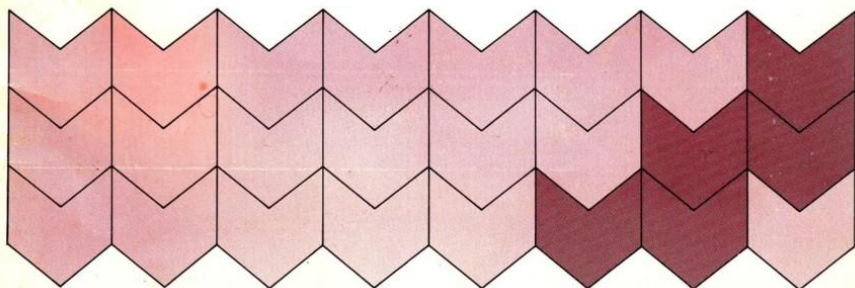

INDEX

1. HOW TO USE YOUR KNITTING MACHINE	
1-1. Setting up your machine	2
1-2. Parts name	5
1-3. Folding up your machine	7
1-4. Threading the yarn tension unit	9
2. BASIC OPERATION PRACTICE	
2-1. Plain knitting	11
2-2. Intarsia knitting	14
2-2-1. How to make intarsia diagram	14
2-2-2. Knit the intarsia	16
2-3. Plating yarn knitting	20
2-4. Pull up stitch pattern	23
2-5. Pull up stitch pattern in two colors	25
2-6. Skip stitch pattern	27
2-7. Skip stitch pattern in two colors	29
3. MAKING GARMENT	
3-1. How to use the transfer tool	31
3-2. How to use the latch tool	31
3-3. How to increase stitches	32
3-3-1. Increasing one stitch (Simple method)	32
3-3-2. Increasing one stitch (Full fashioned method)	33
3-3-3. Increasing several stitches	33
3-4. How to decrease the stitches	34
3-4-1. Decreasing one stitch (Simple method)	34
3-4-2. Decreasing one stitch (Full fashioned method)	35
3-4-3. Decreasing several stitches	35
3-5. Partial knitting	36
3-5-1. Decreasing stitches	36
3-5-2. Increasing stitches	37
3-6. Ribbing stitches	38
3-7. Cable stitches	39
3-8. Casting on 1x1 rib	40
3-9. The waste knitting	41
4. USEFUL HINTS	
4-1. Replacing a needle	42
4-2. Picking up a dropped stitch	44
4-3. Picking up a stitch that has dropped several rows	44
4-4. If the carriage should jam	44
4-5. In case of moving the carriage from side to side without yarn	45
4-6. If the gate pegs catch the yarn	46
4-7. Knitting by using the knit-leader	47
4-7-1. How to set up your knit-leader	47
4-7-2. Tension and knitting a tension swatch	47
4-7-3. How to set the regulators	49
4-8. Maintenance	50
Relation between the tension dial and yarn	14
How to read the operation chart	22
Making Rib	32

1. HOW TO USE YOUR KNITTING MACHINE

1-1. Setting up your machine

1. Release the Upper Carrying Case.
Place the machine as shown in the figure.
Unlock the catches.

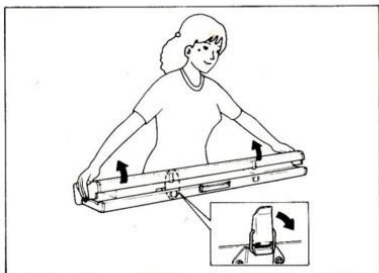

2. Release the Accessories Box and Scales.

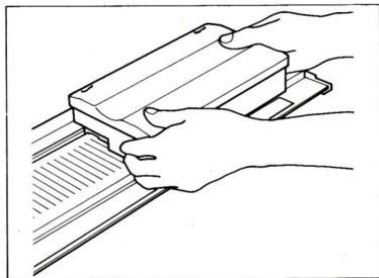

3. Fasten the machine to the table by two table clamps.

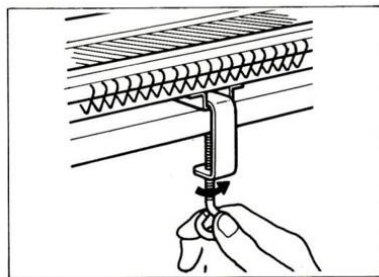

4. Remove the Carriage Lock.

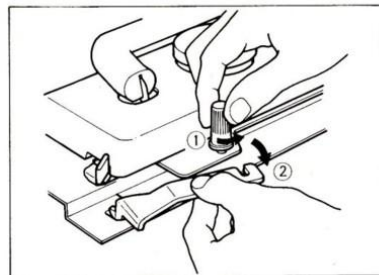

5. Press down the Spring and remove the Sinkers Plate Assembly from the Carrying Case.

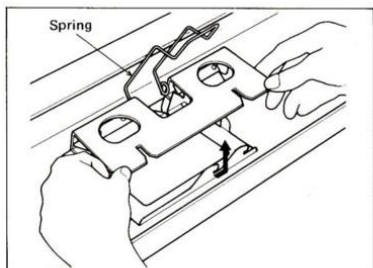

6. Loosen the Thumb Screws and insert the Sinkers Plate under the screws. Tighten the screws.

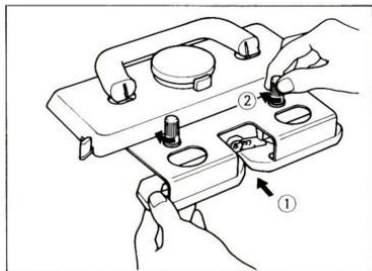

7. Pull the Handle toward you.

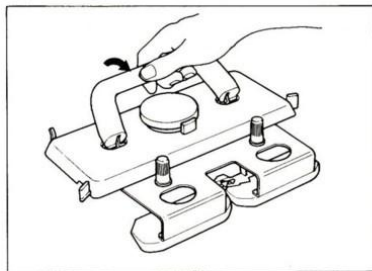

8. Set the Row Counter onto the two pins and push it away from you.

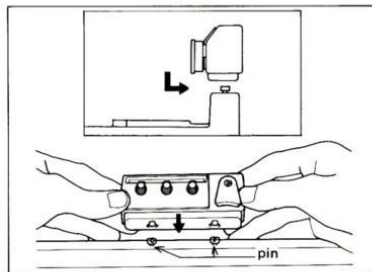

9. Remove the Yarn Tension Unit from the Carrying Case as shown in the figure.

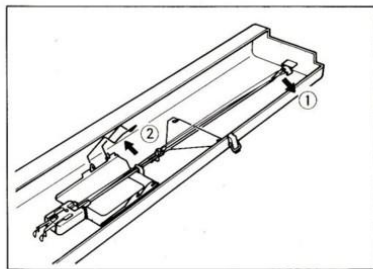

10. Set up the Yarn Tension Unit.

- 1) Push the Take up Spring toward the Tension Case.
- 2) Insert it into the Tension Case as shown in the figure.

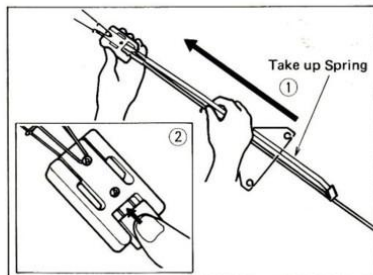

11. Insert Yarn Tension Unit into the hole.

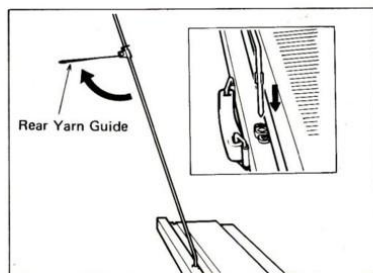

12. Set the Rid of Accessories Box.

- Put the Rid on the pin as shown in the figure.
Use the Rid as accessories box.

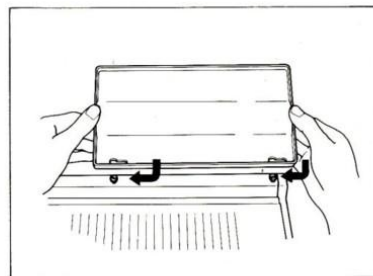

1-2. Parts name

Carriage

1. Stitch Dial
2. Row Counter Tripper
When you knit using Row Counter, set this tripper working position. (lower position)
3. Carriage Handle
4. Change Lever
5. Thumb Screws
6. Plating Yarn Feeder
7. Yarn Feeder
8. Sinkers Plate Assembly
9. Cam Lever
10. Knit Leader Tripper
When you knit with Knit-Leader, set this Tripper working position. (lower position)

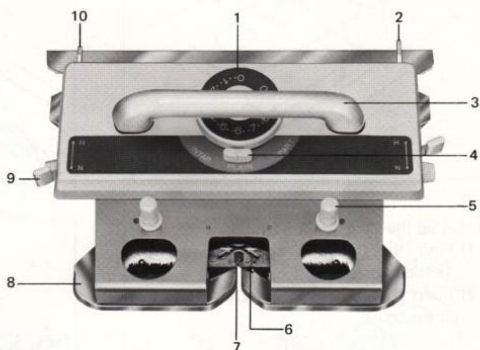

Machine Body

1. Needle Position Indicator
2. Yarn Tension Unit Hole
3. Row Counter Pin
4. Pin for Accessories Box
5. Needle Bed
6. Gate Pegs
7. Needle Position Indicator

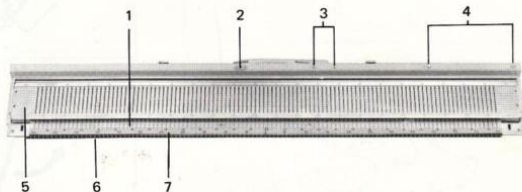

Needle

1. Hook
2. Latch
3. Stem
4. Butt
5. Shunk



Upper Carrying Case

1. Cast-on Comb
2. Sinkers Plate Assembly
3. Yarn Tension Unit

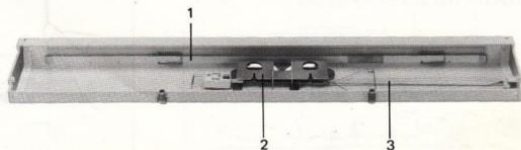

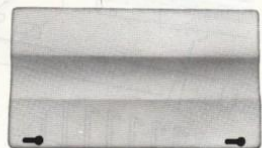

1

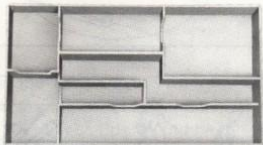

2



3



4



10



11



12



16

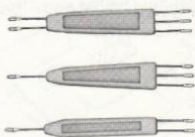

5



6



7



8



9



13



14



17



18



15

Accessories

1. Rid of Accessories Box
2. Accessories Box
3. 0x1/1 Needle Pusher
4. 1/3x3/1 Needle Pusher
5. Transfer Tool
6. Latch Tool

7. Spare Needles
8. Crochet Needle
9. Tapestry Needle
10. Claw Weight
11. Table Clamp
12. Setting Plate for KL116

13. Row Counter
14. Hand Brush
15. Stitch Measure Scale
16. Carriage Lock
17. Special Knitting Oil
18. Cast-on Thread

1-3. Folding up your machine

1. Replace the Cast-on Comb in the Carrying Case. The hook should be put away from you.

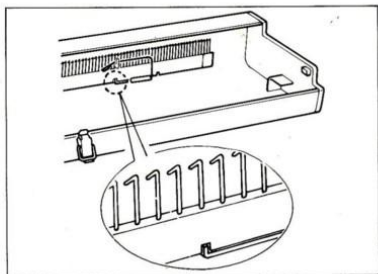

2. Reset the Take up Spring and Rear Yarn Guide.

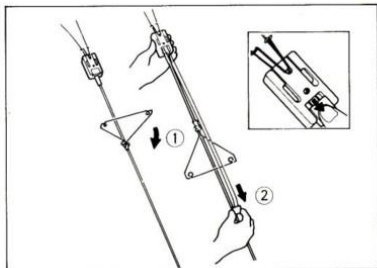

3. Replace the Tension Unit in the Carrying Case. Tension Spring should be put under the Rear Yarn Guide.

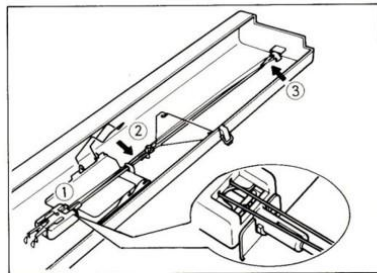

4. Lay the Carriage Handle down as shown in the figure.

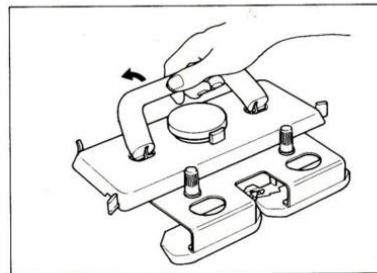

5. Replace the Sinkers Plate Assembly to Carrying Case.

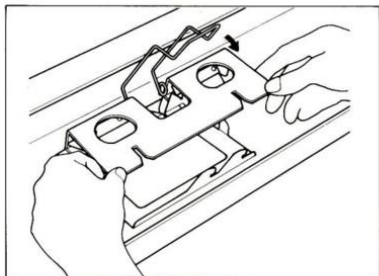

6. Release the Table Cramps from the table and replace them in the accessories box with other parts. Accessories Box should be put on right 54 needle.

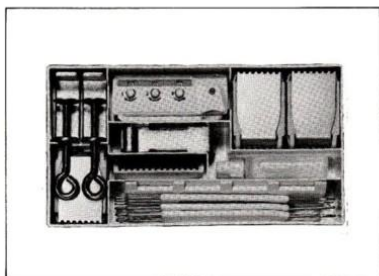

7. Move the carriage to left side. Lock by the Carriage Lock.

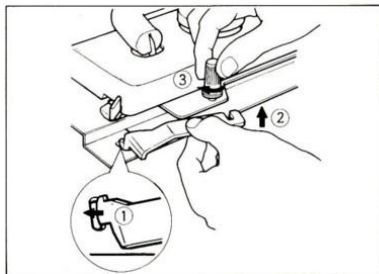

8. Lock the catches.

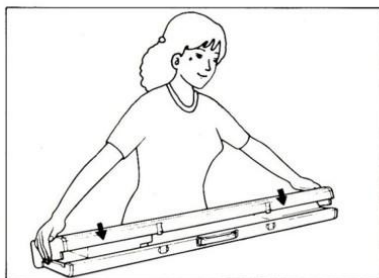

1-4. Threading the yarn tension unit

1. Rear Yarn Guide

Pass the yarn from the ball through the Rear Yarn Guide, sliding the yarn through the Eyelet.

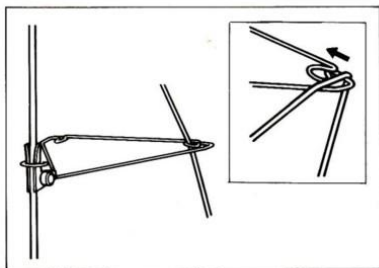

2. Tension Case

Pass the yarn through the Tension Case.

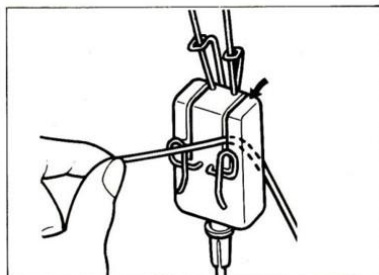

3. Front Yarn Guide

Pass the yarn through the Front Yarn Guide.

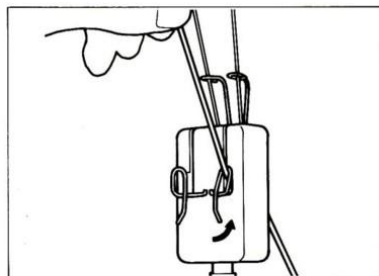

4. Take up Spring

Thread the yarn into the Eyelet of the Take up Spring.

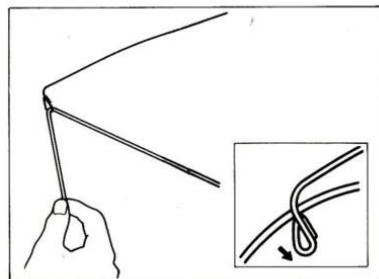

5. Clip the yarn under the Yarn Clip.

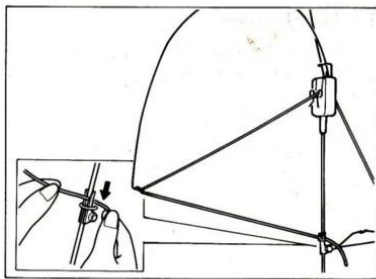

2. BASIC OPERATION PRACTICE

2-1. Plain knitting

1. Set the Tension Dial, Cam Lever Change Lever as shown in the figure.

T.D. (Tension Dial) ; 6
Yarn ; Very Thick

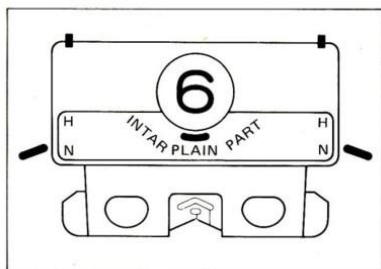

2. Using 0 Needle Pusher, bring forward 40 needles to position "B".
(20 needles on either side of the center mark "0".)

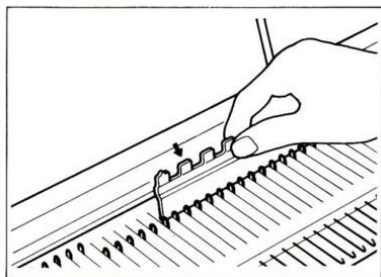

3. Set the Carriage on the Needle Bed and move it across and back to straighten these needles into the position "B". Place the Carriage at right side of the machine.

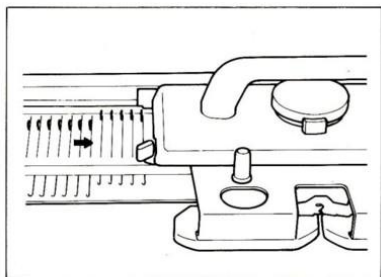

4. Thread the Yarn into the Yarn Feeder after taking it off Yarn Clip.

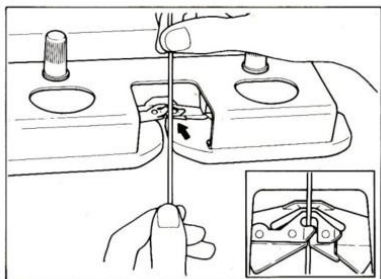

5. Hold the end of yarn with your left hand.

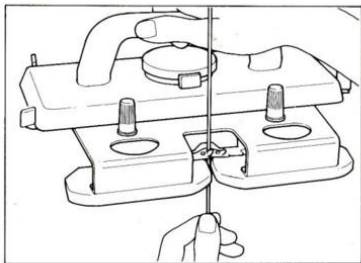

6. Move the carriage to the left.

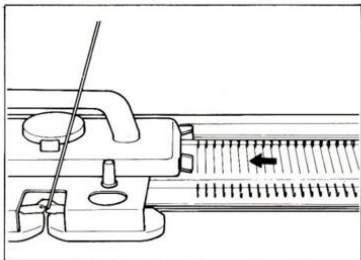

7. Hang the Cast-on Comb.

- 1) Use the 80 needles Cast-on Comb.
At that time Connecting Plate is set on the right side of Cast-on Comb.
- 2) The edge of hook faces the machine as shown in the figure.
- 3) Pull the yarn of carriage side toward you and hang the Cast-on Comb on the stitch as shown in the figure.

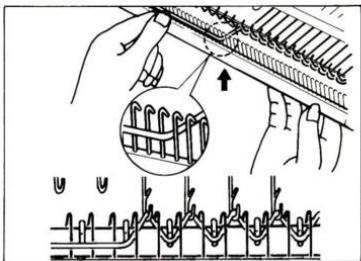

8. Clip the right end of yarn to Connecting Plate as shown in the figure.

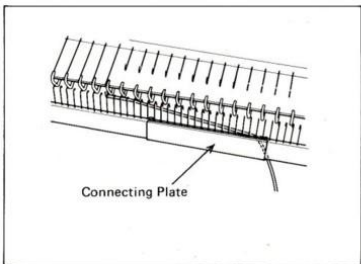

9. Hang the Claw Weights onto the Cast-on Comb to avoid a dropped stitch according to the thickness of yarn and stitches.

	1-30 stitches	31-80 stitches	81-110 stitches
thick	2 claw weights	2	3
very thick	2	3	4
super thick	3	4	4

The claw weight should be positioned equally in the right and left sides of swatch.

10. Move the carriage to the right, holding the yarn with your left hand.

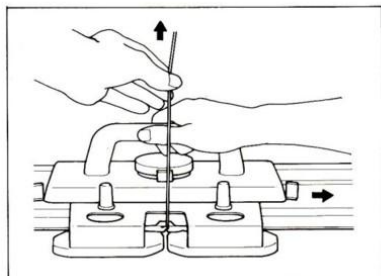
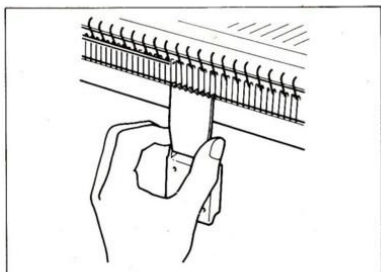

11. Move the carriage to left after the carriage passes the needle "B" position.

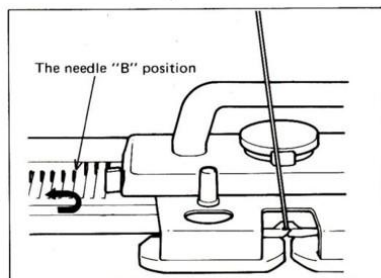

12. Continue to operate the carriage right and left. You are doing plain knitting.

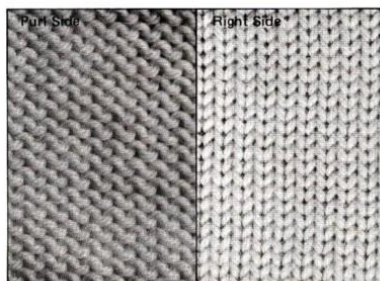

Relation between the tension dial and yarn

The dial is graduated from 0 to 10.
Adjust the dial according to the thickness of the yarn.

thickness of yarn	dial
thick or two strand medium yarn	0-4
very thick or two strand thick yarn	4-8
super thick yarn	8-10

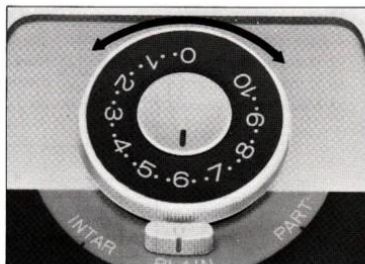

Row Counter

When you set the number "0", turn the knob to the arrow direction from left knob as shown in the figure.

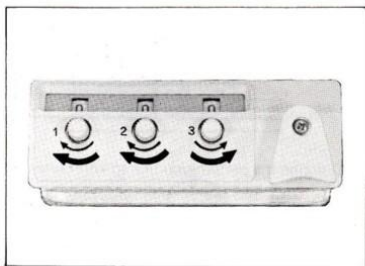

How to use the Cast-on Comb

Using by Connecting Plate, you can use Cast-on Comb properly for 80 needles, 30 needles or 110 needles.

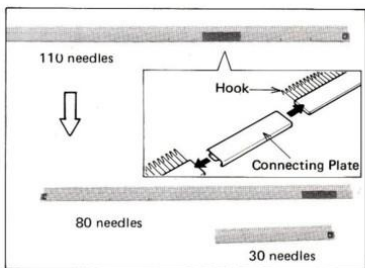

2-2. Intarsia Knitting

Intarsia Knitting does not traverse yarns at the back, and you can knit multi color yarn in one row. When you make the Intarsia Knitting, you need to decide where you put the pattern you like to knit into the garment.

We recommend to you for guide knitting to use Knit-Leader KL116.

Please refer to the instruction manual KL116 for how to use.

If you don't have Knit-Leader, you had better use Intarsia Diagram.

2-2-1. How to make Intarsia Diagram

1) Knitting a Tension Swatch

The size of the stitch is determined by the tension setting on the carriage tension dial. Also it is determined by the thickness, material, brands of wool.

It's necessary to knit a tension swatch samples. (20 stitches x 30 rows)

Please refer to p. 47, "Tension and Knitting Tension a Swatch". for how to make tension swatch samples.

2) Making Intarsia Diagram

Firstly please make the actual diagram according to the size of each stitch.

- If the measurement of the height, 30 rows is 12.0 cm, one row measurement is 0.4 cm.
- If the measurement of the width, 20 stitches is 13.0 cm, one stitch measurement is 0.68 cm.
- Make the actual diagram as shown in the figure.

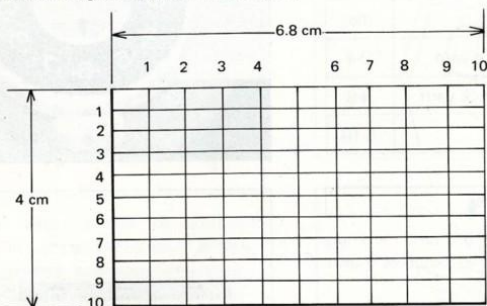

- d) Describe the pattern you like to knit on the diagram.

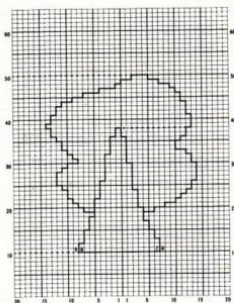

- e) Trace this diagram to graph paper to make easy knitting.

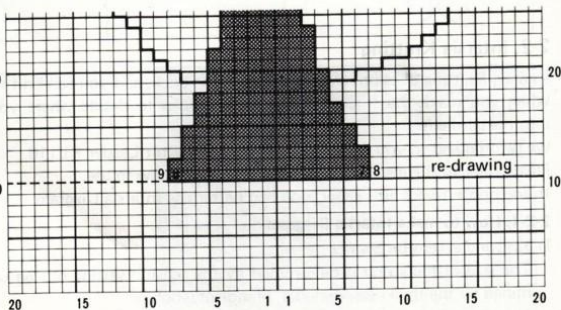
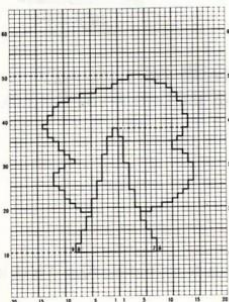

- f) According to the Intarsia Diagram knit the Intarsia.

2-2-2. Knit the Intarsia

T.D. ; 6

Yarn ; Very Thick

Knit the Intarsia according to the diagram.

1-10th row

1. Bring forward 40 needles (both 20 needles from the center) to B position.
Knit the plain knitting 10 rows.
Place the carriage right side.

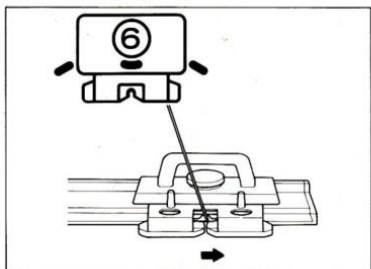

2. Remove the main yarn from the tension unit, yarn feeder.
Place it at your feet.

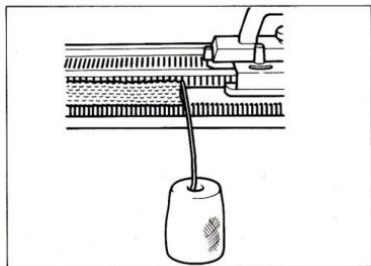

3. Set the change lever to "PART".
Move the carriage to left side.

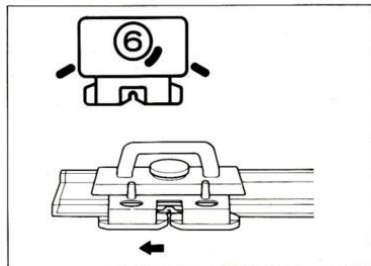

4. Set the change lever to "INTAR".
Move the carriage to right side.
Make sure that the latch of needle is open and needles are selected to D position.

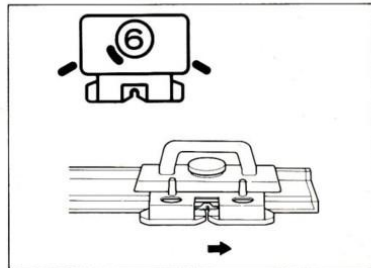

5. Place the contrast yarns which you want to knit at your feet.

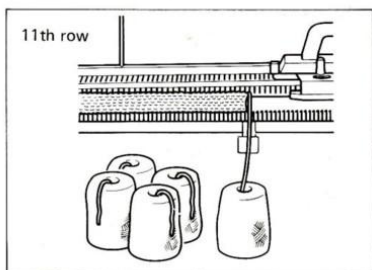

6. Lay the main yarn on the needles, from right end needle to 8th right needle.
Drop the main yarn between 7th right and 8th right needle.

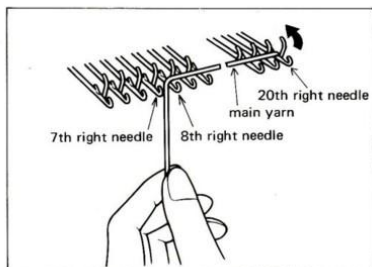

7. Lay the contrast yarn on the needles, from right 7th needle to left 8th needle.
Drop the contrast yarn between 8th and 9th left needle.

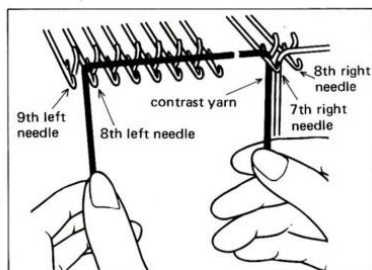

8. Lay the main yarn on the needles, from 8th left needle to left end needle.

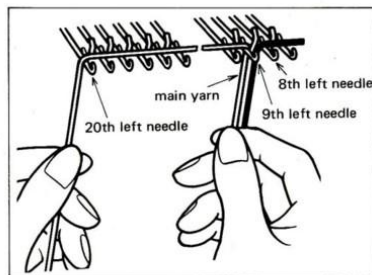

9. Pull all yarn down slightly at your left hand.
Move the carriage to left side.

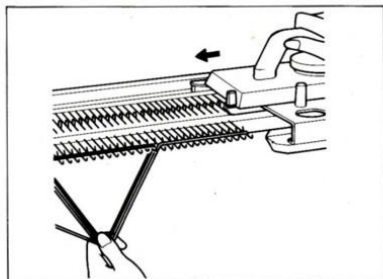

10. The yarns laid on the needles are knitted.
The needles are selected D position again.

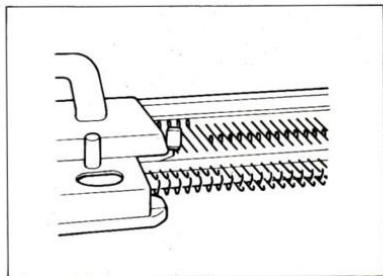

11. Lay the main yarn on the needles from left end needle to 9th left needle.

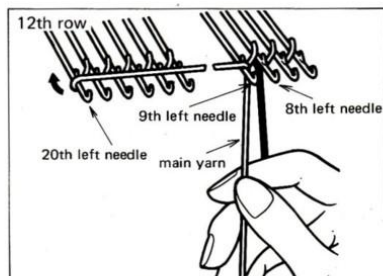

12. Cross the main yarn and contrast yarn
between 9th left needle and 8th left needle.

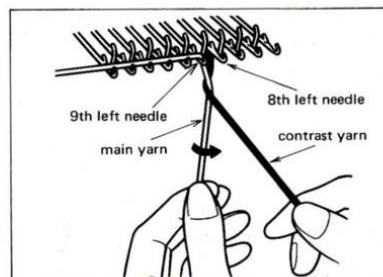

13. Lay the contrast yarn on the needles from 8th left needle to 7th right needle.

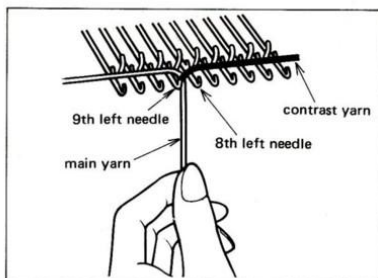

14. Cross the contrast yarn and main yarn between 7th right needle and 8th needle. Lay the main yarn on the needles to right end needle.

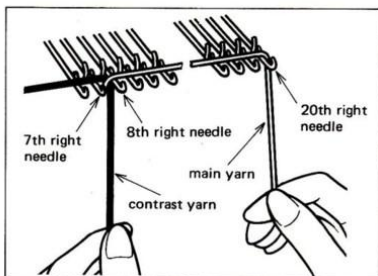

15. Pull all yarns down slightly with your left hand.
Move the carriage to right side.

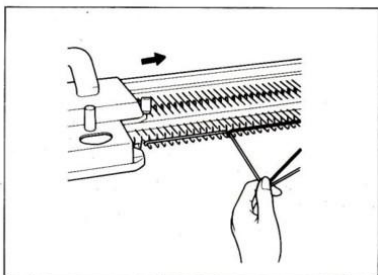

16. On and after 13th row, the operation is the same as 12th row.

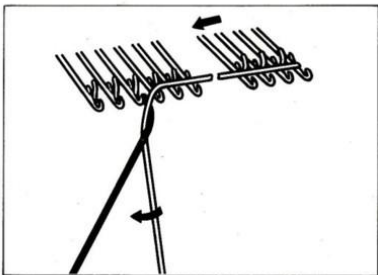

2-3. Plating yarn knitting

It is possible to use two yarns to knit a reversible fabric with different colors on the right side and purl side. The main yarn will appear on the right (plain) side of the fabric and plating yarn will appear on the purl side of the fabric.

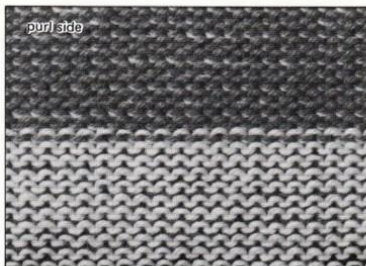
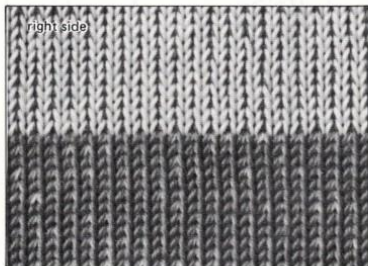

Suggested T.D. (tension dial) number is as follows.

Main yarn	Plating yarn	T.D. number
medium yarn	medium yarn	1-5
thick yarn	thick yarn	6-10

1. Thread yarns through Tension Unit.

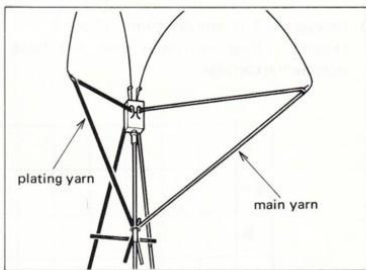

T.D. ; 1, 3

Main Yarn ; Medium

Plating Yarn ; Medium

2. With main yarn knit several rows of plain knitting and place the carriage on the right side.

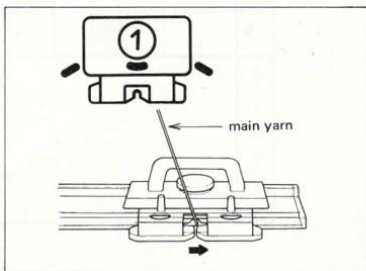

3. Thread the plating yarn through Plating Yarn Guide.

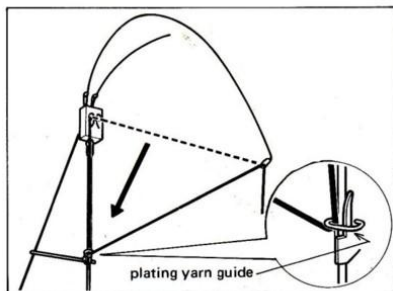

4. Thread the plating yarn into the plating yarn feeder.
Pass the plating yarn behind the yarn feeder.

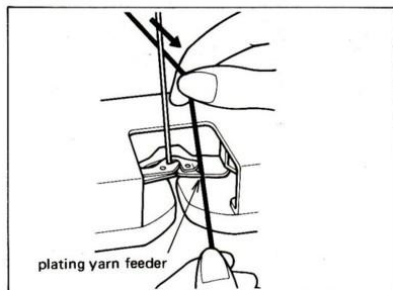

5. Change the T.D. number from "1" to "3".
Holding plating yarn with your left hand,
operate the carriage.

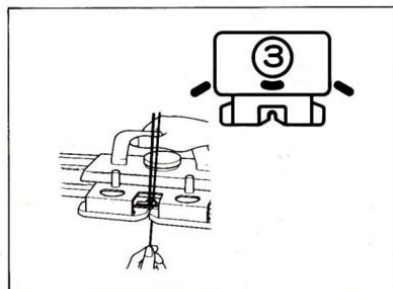

Set the Cam Lever L/R to "H".
Move the carriage to left side.

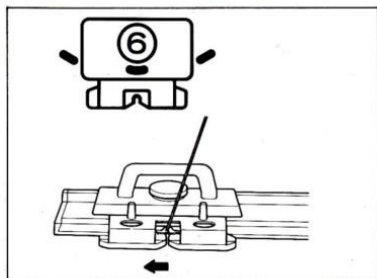

After that the yarn is laid on the needles.

3. Move the carriage to right.
4. Move the carriage to left.
5. Set the Cam Lever R to "N".
Move the carriage to right.

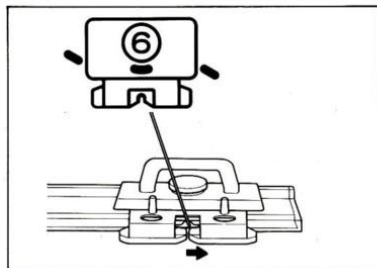

6. Bring forward the needles indicated in the chart to E position.
Set the Cam Lever R to "H". Move the carriage to left.

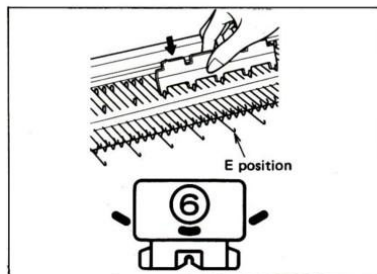

7. Move the carriage to right.
8. Move the carriage to left.

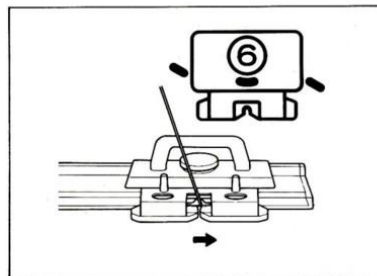

9. Set the Cam Lever R to "N".
Move the carriage to right.
10. Repeat ①-⑧ steps.

3. Move the carriage to right.
4. Set the Cam Lever L to "N". Remove the main yarn from the yarn feeder and rest the yarn on edge of the machine. Thread the contrast yarn through the yarn feeder. Move the carriage to left side.

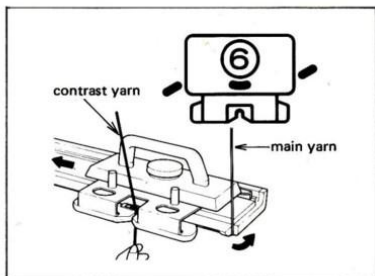

5. Move the carriage to right side.
6. Bring forward the needles indicated in the chart to E position. Set the Cam Lever L to "H". Change the yarn from contrast yarn to main yarn. Move the carriage to left.

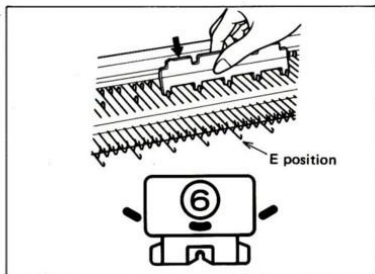

7. Move the carriage to right.
8. Set the Cam Lever L to "N". Change the yarn from main yarn to contrast yarn. Move the carriage to left.
9. Move the carriage to right.
10. Repeat ① - ⑧ steps.

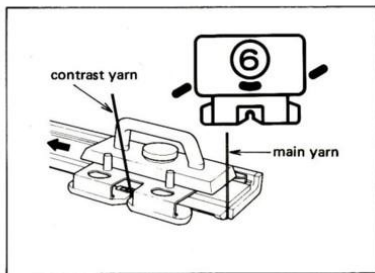

2-6. Skip stitch pattern

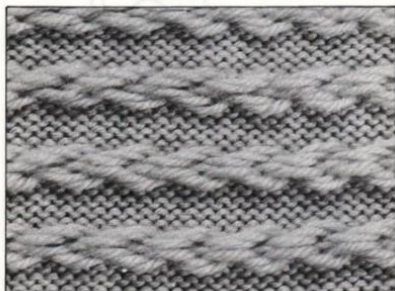

T.D. ; 6, 7

Yarn ; Very thick

1. Knit the several rows of plain knitting and place the carriage on right side.
2. See the operation chart.

By using 1x3 needle pusher, bring forward needles indicated in the chart to D position.

Set the Change Lever to "Part".
Change the T.D. number from 6 to 7.
Move the carriage to left side.

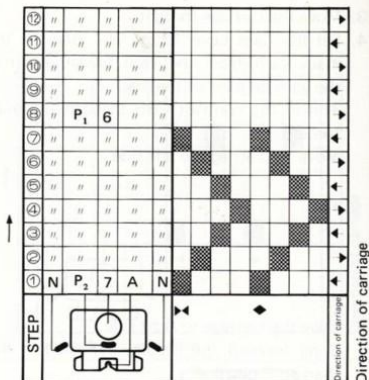

1 pattern 4 stitches 8 rows

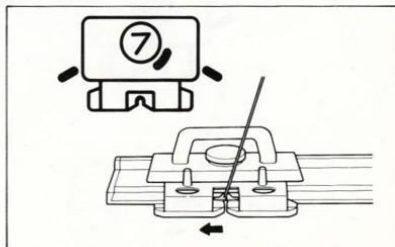
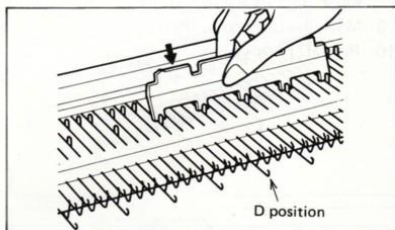
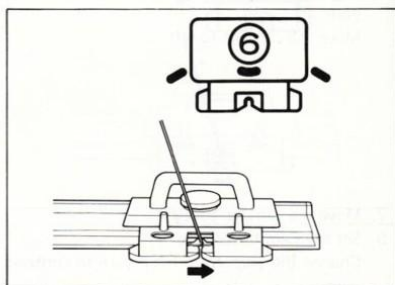

- Bring forward the needles indicated in the chart to D position.
Move the carriage to right side.
- According to operation chart, continue to operate from step ③ to ⑦.

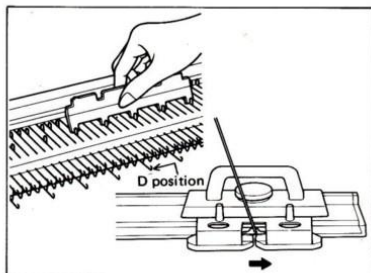

- Set the Change Lever to "Plain".
Change the T.D. number from 7 to 6.
Move the carriage to right.
- According to operation chart, continue to operate from ⑨ to ⑫.
- Repeat ① to ⑫.

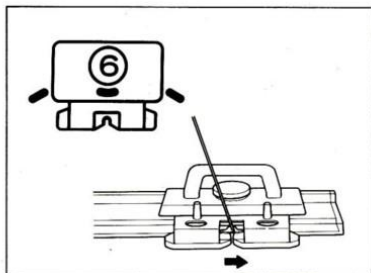

2-7. Skip stitch pattern in two colors

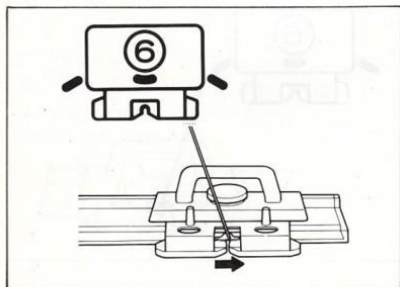
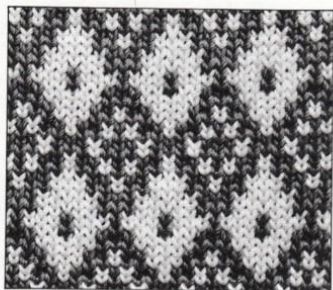

T.D. ; 6

Main yarn ; Very thick

Contrast yarn ; Very thick

1. Thread the main and contrast color yarn into the yarn tension unit. After knitting several rows of plain knitting with main yarn, place the carriage on the right side.
2. See the operation chart.

By using 1x3 needle pusher, bring forward needles indicated in the chart to D position. Set the Change Lever to "Part". Change the yarn from the main yarn to contrast yarn. Move the carriage to left side.

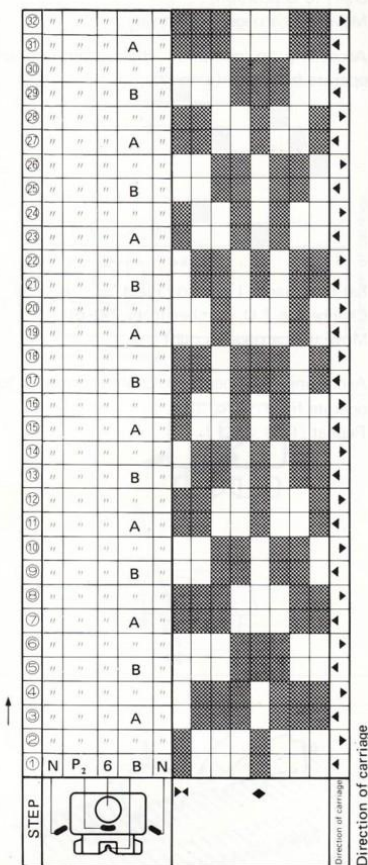

1 pattern 8 stitches 16 rows

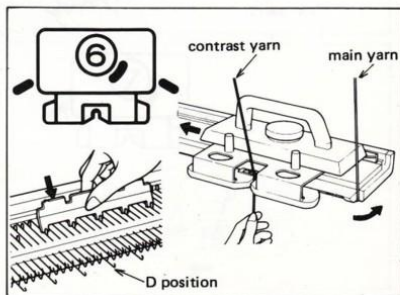

3. Bring forward needles which are the same needles at first row to D position.
Move the carriage to right.

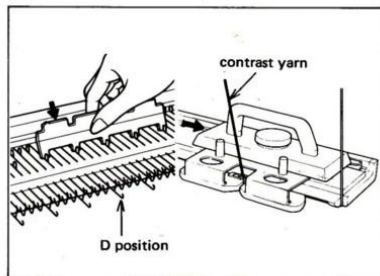

4. By using 3x1 needle pusher, bring forward the needles which are not brought at 1st and 2nd rows to D position.
Change the yarn from the contrast yarn to main yarn.
Move the carriage to left side.

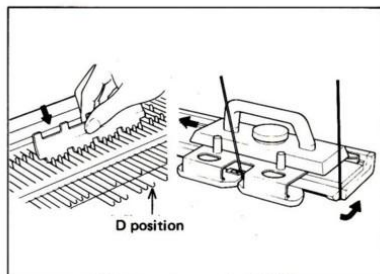

5. Bring forward the needles which are the same needles at 3rd row to D position.
Move the carriage to right side.
6. According to the operation chart, continue to operate from ⑤ to ⑳.

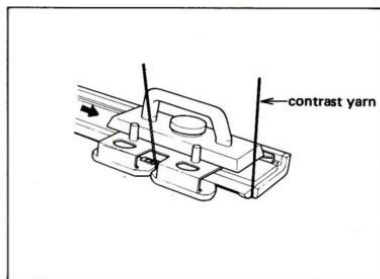

3. MAKING GARMENT

3-1. How to use the Transfer Tool

Use when you decrease, increase, transfer stitches and so on.

How to hold the transfer tool

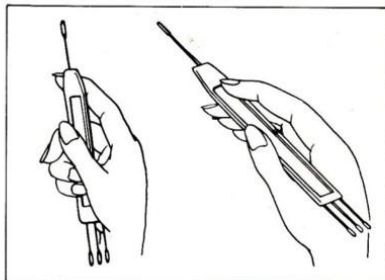

Transferring Stitch

1. Hook the needle with Transfer Tool and pull toward you.
2. Push back the Transfer Tool with the needle until the stitch is transferred onto the transfer tool.
3. Remove the Transfer Tool onto the hook of the adjacent needle and transfer the stitch.

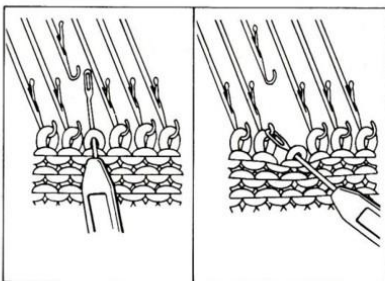
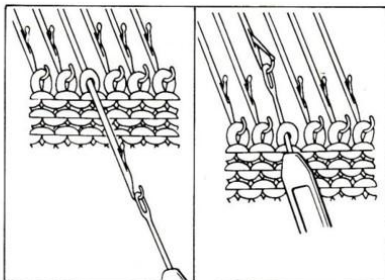

3-2. How to use the latch tool

Use when you make ribbing, pick up dropped stitch and so on.

How to hold the latch tool

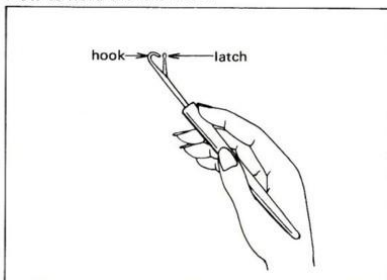

Making Rib

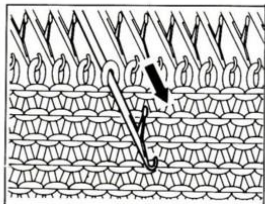

1. Bring one needle forward to position E by hand and return it to position A.

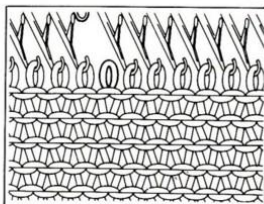

2. One stitch has been dropped from the hook of the needle.

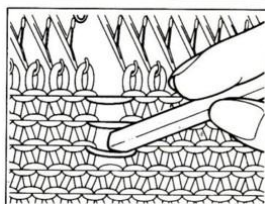

3. Using the tip of your Latch Tool, unravel your knitting.

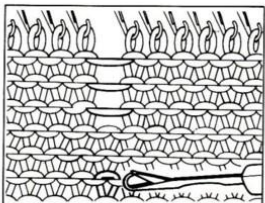

4. Drop the stitch in the line you wish to rib to a few rows above where you are to start ribbing. Then place the Latch Tool in the stitch where you wish to start ribbing.

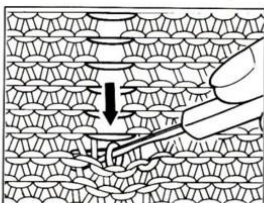

5. Depress the Latch Tool to drop the last few stitches. The stitch is on the stem of the Latch Tool.

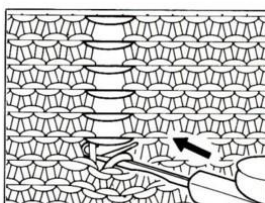

6. Hold the knitting firmly. Push the Latch Tool away from you until the stitch on the latch tool is behind the latch.

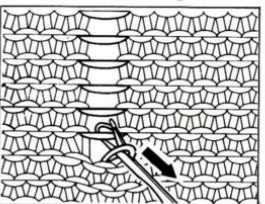

7. Catch the next parallel thread with the hook of the latch tool and pull the Latch Tool toward you.

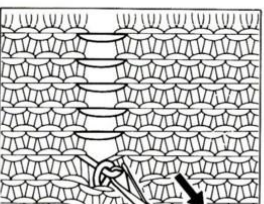

8. The latch will close with the new yarn in the hook. Pull this new yarn through the stitch on the stem of the latch tool to form a new stitch. Do not pull the latch tool strongly.

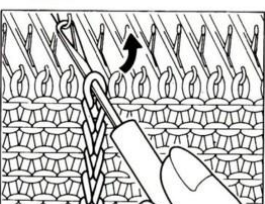

9. Repeat this until you reach the top, and hook the last stitch on the hook of the needle.

3-3. How to increase stitches

3-3-1. Increasing one stitch (Simple method)

On the carriage side

1. On the carriage side, push one edge needle from position A to E.
2. Knit one row, and the empty needle will pick up the yarn.

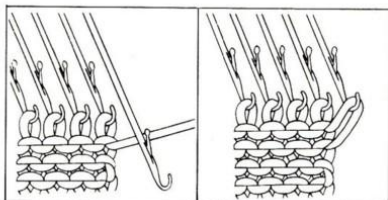

- Knit another row, and one stitch will be formed.

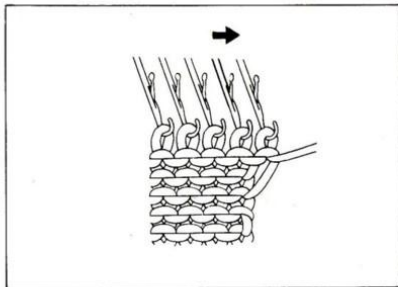

3-3-2. Increasing one stitch (Full fashioned method)

At either side of knitting

- Using the Transfer Tool, move one stitch of edge out one needle, so that the second needle from the end becomes empty.
- Pick up the one lower stitch of the 3rd needles from the edge with the Transfer Tool.

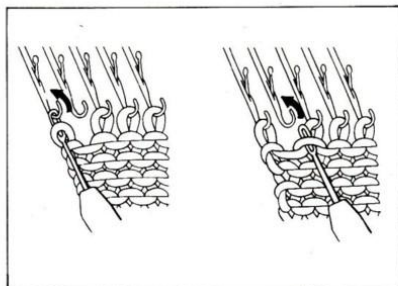

- Hook the stitch onto the empty needle.

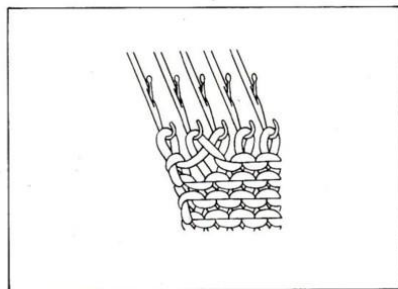

3-3-3. Increasing several stitches

On the carriage side

- On the carriage side, pull the needles to be increased, to position E from A.

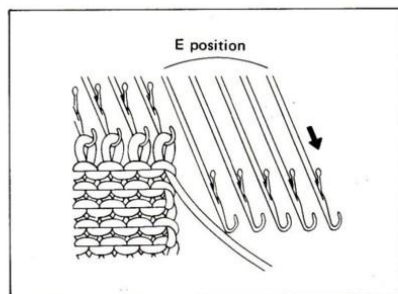

2. Wind the yarn loosely around the stems of each needle, but only on the edge needle pass the yarn under the needle.

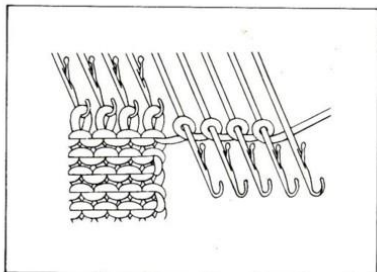

3. Knit one row. If not smoothly, pull the needles to increase stitches to position E.

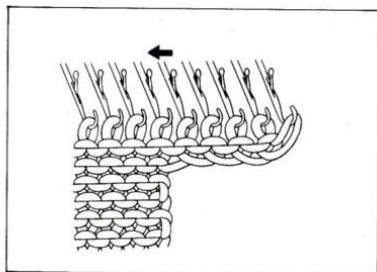

3-4. How to decrease the stitches

3-4-1. Decreasing one stitch (Simple method)

1. Remove one stitch of the edge needle to the Transfer Tool.
2. Hook the Transfer Tool onto the inside adjacent needle.

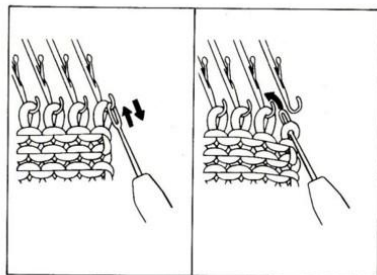

3. Return the empty needle to position A.

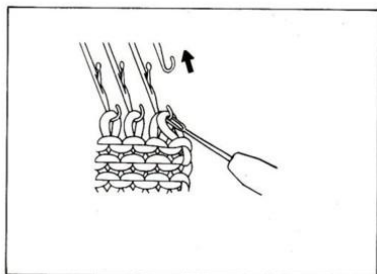

3-4-2. Decreasing one stitch (Full fashioned method)

1. Remove two stitches on the edge to 2 eyed Transfer Tool.
2. Hook the Transfer Tool inside one needle, and then transfer stitches.

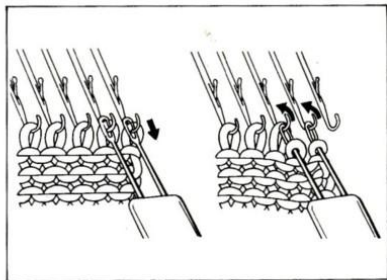

3. Return the empty needle to position A.

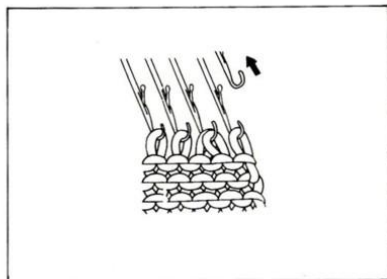

3-4-3. Decreasing several stitches

1. On the carriage side, using the Transfer Tool, transfer the stitch on 2nd needle onto the edge needle.
2. Transfer the double stitches on the edge needle inside one needle, and bring backward the empty needle to position A.

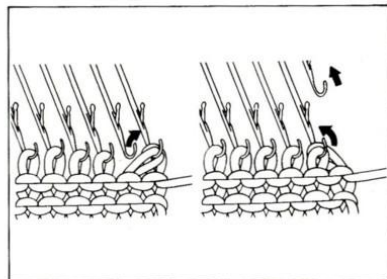

3. Place the yarn in the needle hook, back the needle manually to form a single stitch.

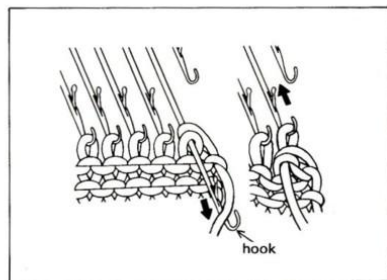

4. Repeat the process from Setp ① to Step ③.
(But the last stitich is done until Step ②)

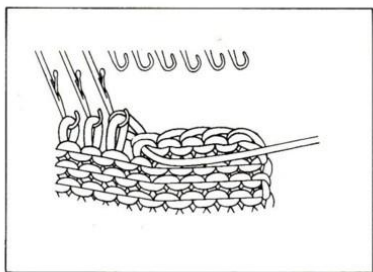

3-5. Partial knitting

3-5-1. Decreasing stitches

When knit the decreasing part for example shoulder, neck opening, and so on, set Cam Lever L/R to "H".

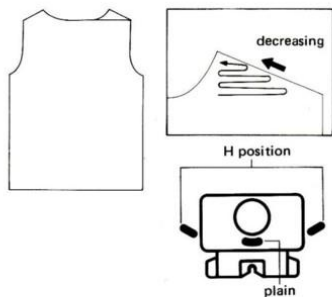

1. On the opposite side of the carriage, bring forward the needles which you want to decrease to position E.

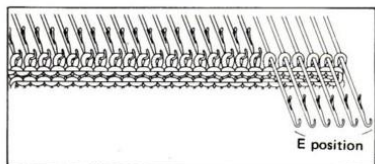

2. Knit one row. The needles in position B are knitted, and in position E the yarn will pass on the needles.

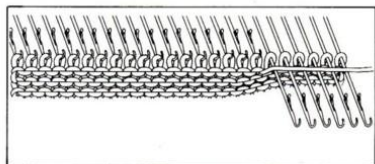

3. Pass the yarn under the stem of the first needle on position E as shown in the figure.

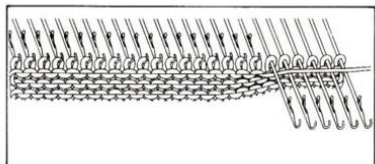

4. Knit one row.

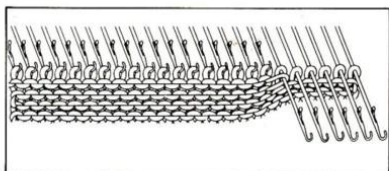

5. Continually move the needles to decrease to position E, and repeat the process from Step ① to Step ④.

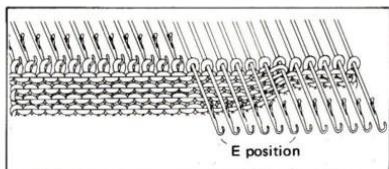

3-5-2. Increasing stitches

When knit the increasing part for example the hem line of skirt, set Cam Lever L/R to "H".

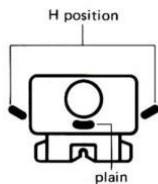
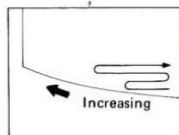

1. On the opposite side of the carriage, bring the needles not to be knitted forward position E.

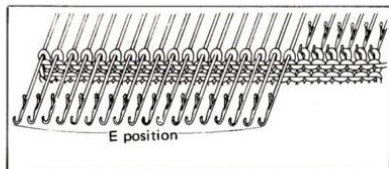

2. Knit one row, and the needles in position B are knitted, not in position E.

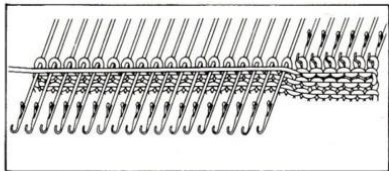

3. Pass the yarn under the stem of the first needles in position E.

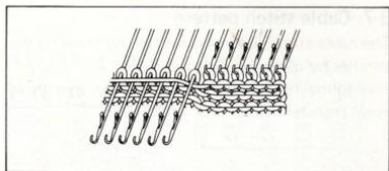

4. Knit one row.

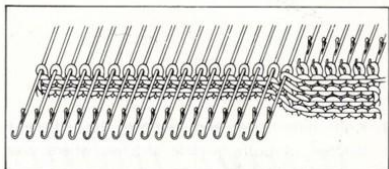

5. Manually bring backward the needles to be increased from position E to D.

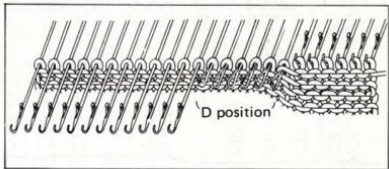

6. Knit one row, and the needles which you brought to position D are knitted.

7. Repeat the process from Step ③ to Step ⑥.

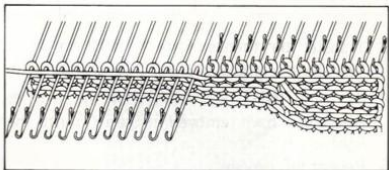

3-6. Ribbing stitches (1x1 rib)

The 1x1 rib is alternating with one right and one purl stitch in one row.

It is used for waist bands, cuffs, collars and so many positions.

Refer to page 31, "How to use the Latch Tool".

Alter the purl stitch into the right one on every other needle using Latch Tool.



3-7. Cable stitch pattern

The cable stitch pattern is knitted by crossing the stitches by using the Transfer Tool.

The following example is knitted by two three eyed Transfer Tools.



1. Knit nine rows and remove the adjacent stitches of both outside stitches where you wish the cable stitch pattern.
2. Pick up each three stitches by two Transfer Tools.

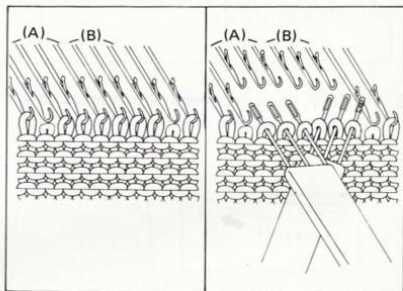

3. Transfer the stitches (A) to (1) position.
Transfer the stitches (B) to (2) position.
4. By using the Latch Tool, alter the stitches which you have removed in Step ① into the right stitch.
5. Repeat this process.

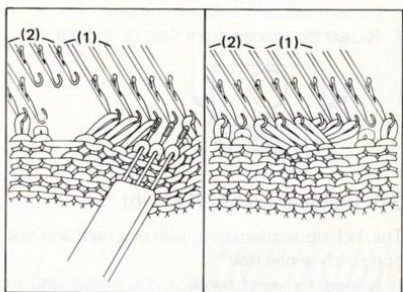

3-8. Casting on 1x1 rib

1. Bring forward every other needle to position B by 1x1 needle pusher. (But two needles in the right edge side should be brought)
2. Knit the several rows with the waste yarn, and continually knit one row with cast-on thread.
3. For casting on with bound edge, knit three rows with the garment yarn. At this time T.D. is lower 4 Number than main tension. With the Transfer Tool pick up the 1st sinker loop yarn and transfer to edge needle. Bring forward the needles in the position A which are non-working position to position B.
4. Knit the plain knitting by the rows you want to rib. Adjust T.D. to higher 2 Number than casting-on.
5. Drop the stitches in the line of the 3rd needle from the right edge, alter the purl stitch into the right stitch by the latch tool on the every other needle.
6. Pulling down the garment with your left hand, catch with the latch tool the 1st sinker loop of garment yarn.
7. Skip 2 loops and insert the latch tool under the 4th loop of the garment yarn and continually catch the loop up row by row.

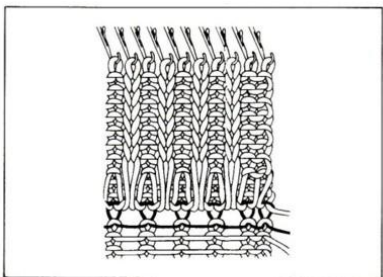
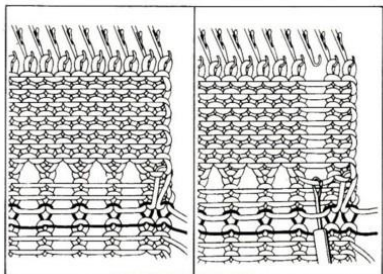
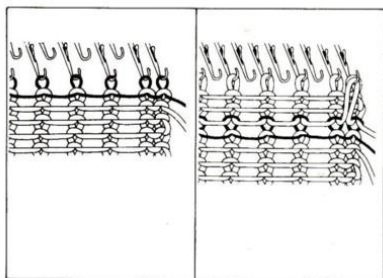

3-9. The waste knitting

The waste knitting is the extra plain one not to be unravelled garment.

1. Knit about ten rows with waste yarn, and place the carriage on the right side.

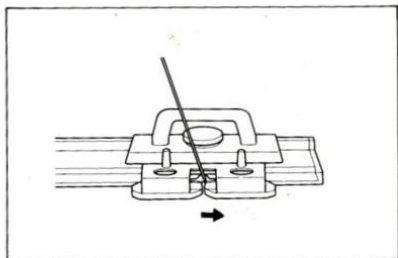

2. Knit one row with cast-on thread.

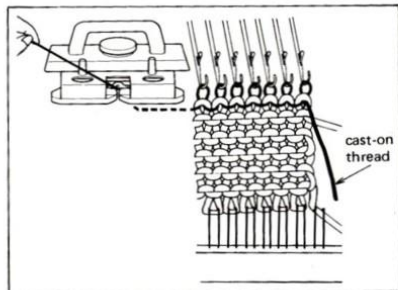

3. Take the waste yarn out of the yarn feeder, and knit by the garment yarn.

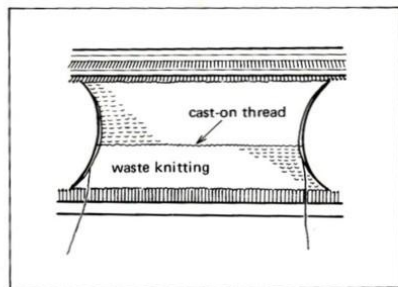

4. Pull out the cast-on thread, and part knitted with the waste yarn is taken off.

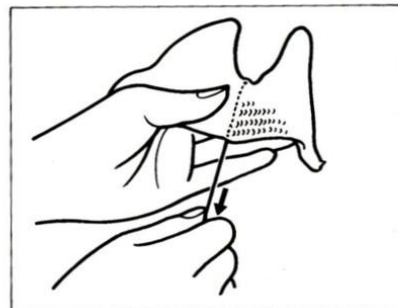

4. USEFUL HINTS

4-1. Replacing a needle

1. Push the sponge bar with the handle of the latch tool.

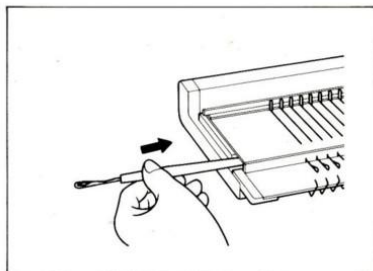

2. Draw it by hand until the edge of the sponge bar pass through the needle to replace.

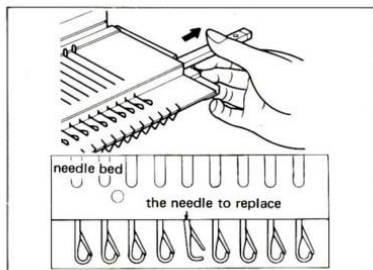

3. Push the needle forward position E.

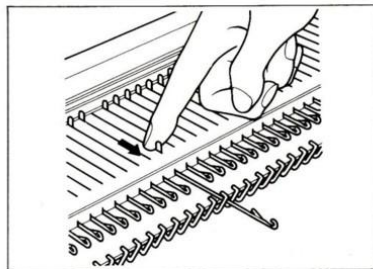

4. Push down the hook of the needle until shank end of the needle rises clear from the needle bed.

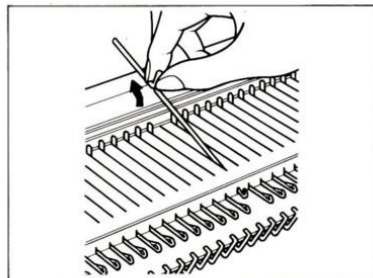

5. Replace it with a new needle and insert a new needle toward position E.

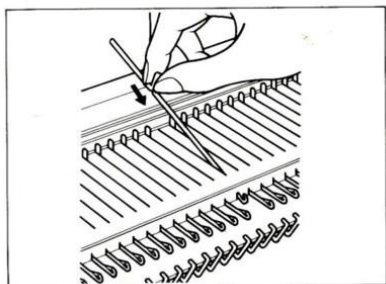

6. Push the needle back to position A.

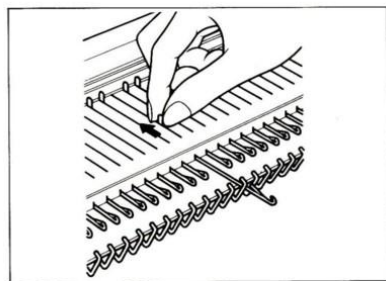

7. Push the sponge bar back holding the hook of the needles down with your hand or needle pusher.

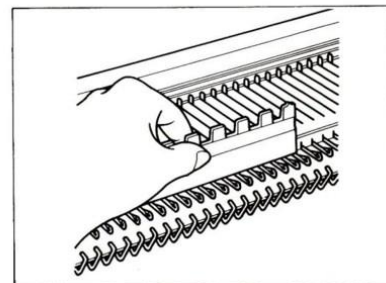
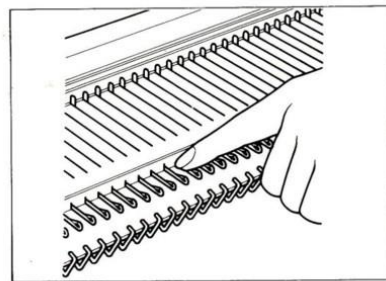

4-2. Picking up a dropped stitch

Using the transfer tool, pick up the stitch (the row below the dropped stitch) and make up the stitch by hook the loop to the needle.

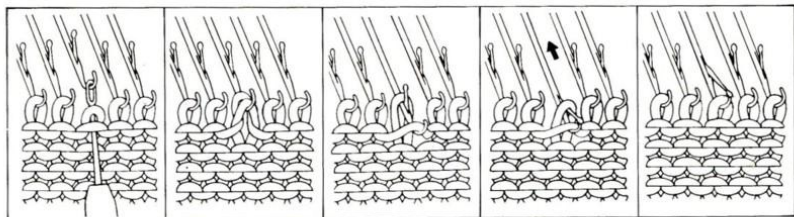

4-3. Picking up a stitch that has dropped several rows

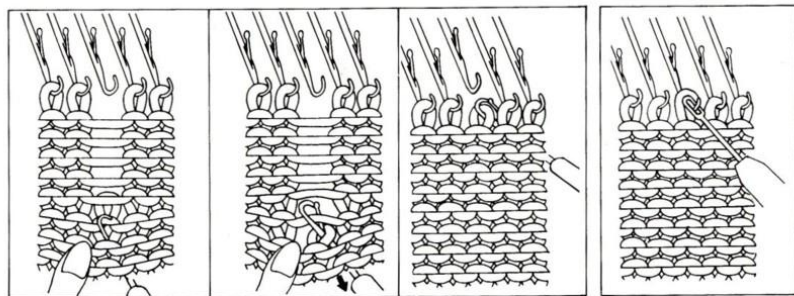

1. Using the Latch Tool, over the knitting, hook the stitch and make the stitch row by row.

2. Transfer the stitch from the Latch Tool to Transfer Tool at the last row, and hook the stitch to needle.

4-4. If the carriage should jam

1. Be loosen the knob and remove the sinker plate assembly.

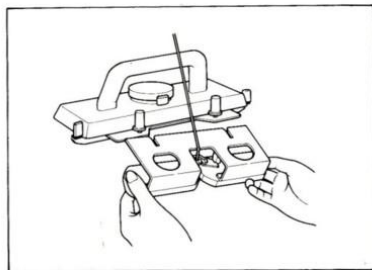

2. Lift up the carriage to remove and place the carriage at the side toward which the carriage was moved.

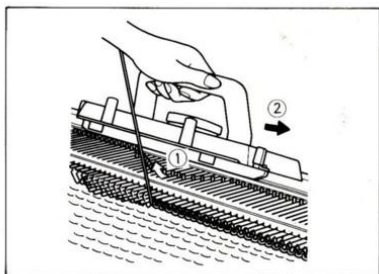

3. Replace the stitch on the stem by Transfer Tool to the latch of the needle.

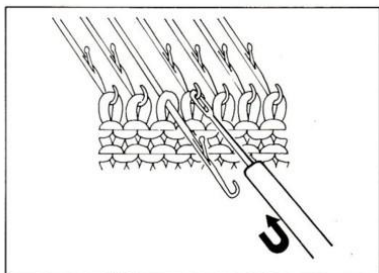

4. Unravel one row of knitting.

- 1) Pull the yarn slightly.
- 2) Unravel one row, swinging the yarn slightly back and forth.

Make sure that the stitches are on the latch of the needles and return the needles to position B.

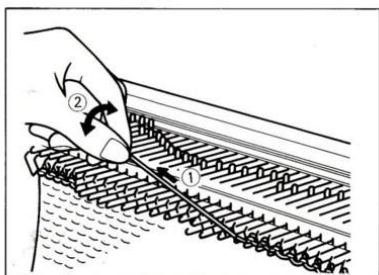

4-5. In case of moving the carriage from side to side without the yarn

1. Place the stitch back into the latch of needle if on the stem.

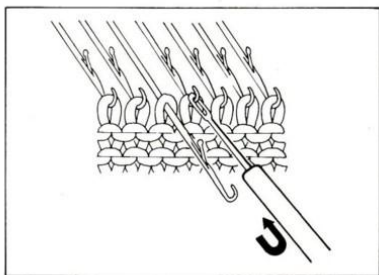

2. Arrange the needles in position B.
3. Setting change lever to "Part", move the carriage without yarn.

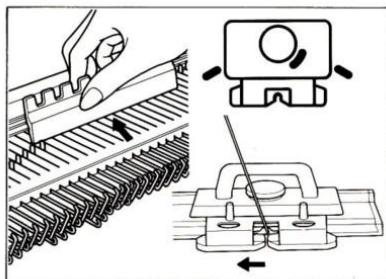

- *If the needles are in position E.
Setting Cam Lever L/R to "H", move the carriage without the yarn.

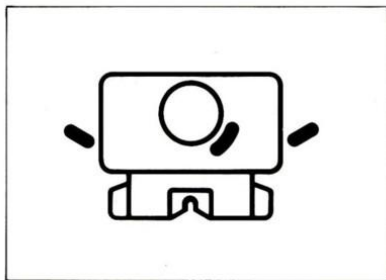

4-6. If the gate pegs catch the yarn

If the yarn remains caught by the gate pegs, it is difficult to knit.

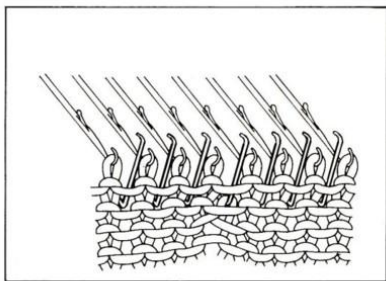

1. Bring the Latch Tool with the latch toward you.

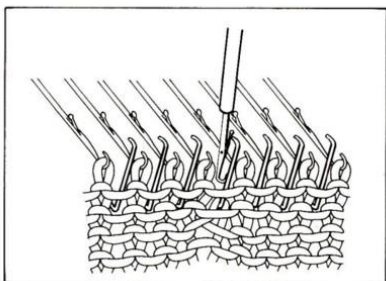

- Hook the yarn caught by the gate pegs and remove it over the gate pegs.

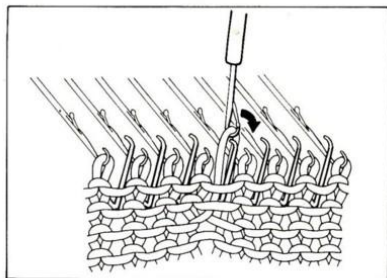

4-7. Knitting by using the knit-leader

4-7-1. How to set up your knit-leader

- Use the Setting Plate included in accessories.
- Put the narrow part of Setting Plate upon the Setting Plate Holder, and pull the Setting Plate toward you.
- Insert the Setting Plate into the solts at the back of the KH230.
(Refer to the instruction manual of KL116.)

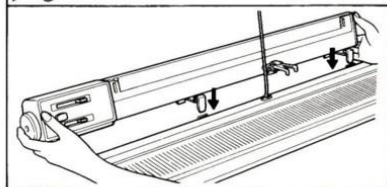
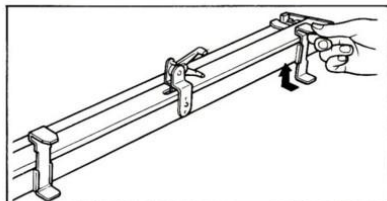
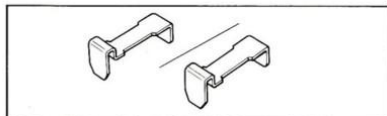

4-7-2. Tension and knitting a tension swatch

In order to knit according to the correct size of your pattern, you need to know the size of the stitch. The size of the stitch is determined by the tension setting on the carriage tension dial. Also it is determined by the thickness, material, brands of wool. It is necessary to knit always a tension swatch samples when you make a garment. Please make a tension swatch and measure length of 30 rows and 20 stitches of the swatch.

- Set the Row Counter number 000.
Set the Row Counter Tripper and Knit-Leader Tripper to working position.

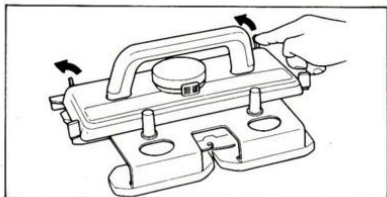

2. Bring forward 40 needles (20 needles on either side of center mark) to position B, and knit ten rows with original yarn.

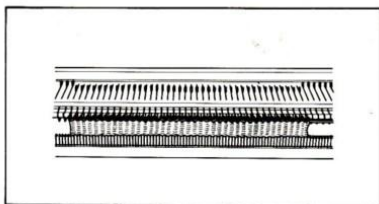

3. Remove the original yarn and knit 2 rows with different color yarn.
The Row Counter is 012.

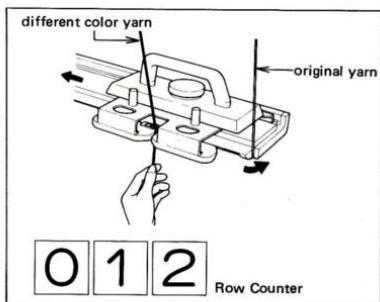

4. Re-thread the original yarn and knit 15 rows.
The Row Counter is 027.

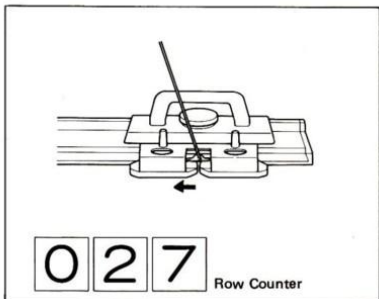

5. Bring forward both 11th needles from the center to position E.
Hook the different yarn into the 2 needles and make stitches as shown in the figure.

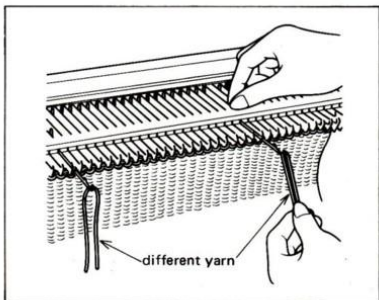

6. Continually knit 15 rows again.
The Row Counter is 042.

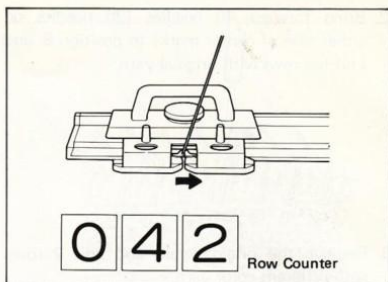

7. Remove the original yarn and knit 2 rows
with different color yarn.
The Row Counter is 044.

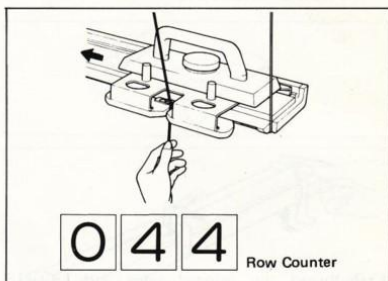

8. Re-thread the original yarn and knit 10 rows.
The Row Counter is 054.

9. Remove the swatch from the knitting machine.

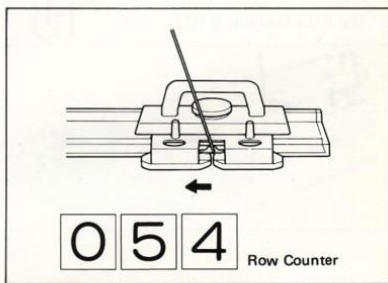

4-7-3. How to set the Regulators

After you apply steam to the swatch with a steam iron, set the regulators.

1. Measure the height of 30 rows (inside of different color yarn).
Set the Regulators referring to KL116.
2. Measure the width of 20 stitches (inside of 2 different color stitches). Set the Stitch Measure Scale included in accessories.

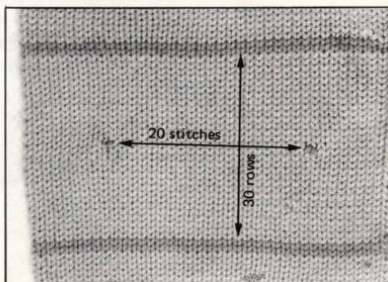

4-8. Maintenance

Keep clean your machine

Wipe the carriage cover and carrying case with dried cloth.

Brush away the dust on the needle position indicator.

If you use machine after it has not been used for a long time

Wipe the following parts of the machine with oiled cloth.

- *On the needle bed
- *Butts of needles
- *Front and rear rails of needle bed
- *Back side of carriage

When you feel the carriage don't move smoothly

Wipe with oiled cloth the following dotted line in the back side of carriage.

