

BRAMWELL

DESIGN  
FOR  
DUOMATICS  
BOOK TWO

*by Eileen Metcalf*









**TWO OR THREE COLOUR TUCK WAISTCOATS**  
*Fine 4-july*



**ZODIAC SUIT**



**ADULT'S SIDWAYS KNITTED SWEATER** *Fine*  
*3 ends 9/30 Bramwell yarn or 1 straw 4-july*  
*n.54*



**ONE SIZE SWEATER IN ASTRAKAN**





HALF FISHERMAN'S RIB JACKETS *Fine 4-ply*



SNOWMEN, HOT WATER BOTTLE COVER,  
GOLF CLUB COVER



SKIRT IN ARTISTIC  
TOP WITH DIAGONAL STRIPES



SWEATERS WITH FAIRISLE BANDS  
*Fine 4-ply*



# 1050

## INTRODUCTION

As in "Design for Duomatics", this book provides a wide spectrum of patterns for all members of the family and for knitters of varying abilities. There is a progression from simple tops and bazaar items for the beginner, to patterned sweaters and suits for the more experienced knitter. Techniques such as buttonholes, intarsia and cut and sew V neckbands are incorporated into the patterns which not only use the ever popular 4 ply, 2/30's, Ivette, Zodiac and Artistic yarns of Bramwell but their new fine yarns of Duo-Spun and Montana Cotton which are particularly economical on the Duomatic machine.

In test knitting all these garments, I found that Eileen has provided once again a range of patterns which can be greatly increased in number by the use of one's own imagination and creativity. The dress in Montana Cotton is particularly easy to convert into a lovely skirt and summer top, the latter being quickly knitted from oddments of yarn. The well written, easy to follow instructions and diagrams gave me great confidence and I hope you enjoy knitting them as much as I did.

Christina Salisbury

## CONTENTS

Tuck stitch top.....	8
To turn the top into a sweater with sleeves.....	8
Half Fisherman's rib jacket.....	13
Zodiac suit.....	16
Two or three colour tuck waistcoat.....	18
Stocking stitch sweater with cut in sleeves.....	24
Sweater with Fairisle bands.....	30
Jacquard Jacket.....	33
One size sweater in Astrakan.....	37
Artistic skirt.....	39
Top with diagonal stripes in Artistic.....	40
Intarsia top in Artistic.....	44
Dress in Montana cotton.....	48
Child's sideways knitted sweater.....	49
Adult's sideways knitted sweater.....	54
Two colour tuck sweater.....	57
Snowmen.....	62
Hot water bottle cover.....	62
Golf club cover.....	62

Thank you to  
Raymond Thomas M.A. for his help and advice as a photographer.  
Christina Salisbury for test knitting and for the invaluable help which she gives in so many ways.  
To Margaret Turner of Leyland for the original snowman pattern.

Photography by Raymond Thomas Photography "Ashdown", Moss Lane, Leyland, Lancs. England.

First printed 1987  
© Metbury Designs, 1987  
Printed in United Kingdom

Although every effort has been made to ensure that the patterns in this book are correct, the author accepts no responsibility for any damage, loss or the like arising from their use.

## TENSIONS

Where a 1x1 rib cast on is indicated, the tension is measured over all needles including those on the back bed. Where an every needle rib cast on is used, the tension is measured over the needles on the front bed. The back bed needles are not included in the counting.

Tension dial numbers are given for the Duo 80. They should be lowered by at least half a number for the Duo 5.

## ABBREVIATIONS

R	Rows	ST	Stitches	S/S	Stocking stitch	RC	Row Counter
E/R	Every Row	A/R	Alternate rows	2/R	Alternate rows	3/R	Every third row
+1	Increase 1 stitch	-1	Decrease 1 stitch	1x	1 time	2x	2 times
3x	3 times	in	inches	cm	centimetres	E/N	Every needle rib.

## PRESSING

Artistic and Ivette :- unless otherwise stated in the pattern, use a cool iron.

Fine 4 Ply, 2/30's, Duo-Spun, and Zodiac :- Set the iron to give off the maximum steam. Hold the iron over the garment but not touching it, then pat into shape.

### SINGLE BED CAST ON USING WASTE YARN

Push up to working position the number of needles required. Bring a pusher out of the blocking rail for each of these needles. Set the pushers one up one down all the way across.

GX/BX Both arrow keys pushed in. Black strippers. Handle down. Tension 5½ for 4 Ply or Tension 5 for 3 Ply.

Knit 2 rows slowly.

GX/N Tension 6½ for 4 Ply or Tension 5 for 3 Ply.

Knit several rows slowly until all the needles are knitting properly. Change to main yarn.

### TO CAST ON FOR EVERY NEEDLE RIB

Handle down. Bring the total number of needles shown on the diagram into working position on the front bed. Bring the same number up on the back bed. The outside needle on the right should be on the back bed. The outside needle on the left should be on the front bed. For all the garments in the book where every needle rib cast on is used the number of needles given will be for the front bed only and the same number will be required on the back bed.

Orange strippers. N/N Tension 2/2. Knit one row. CX/CX Tension 3/3. Knit two rows ( i.e. One on the back bed and one on the front).

N/N Tension 3/3. Knit one row.

### TO CAST ON IN 1x1 RIB

Handle up. There is no need to count the needles individually. Push all the required number of needles up on the front bed. Now use the orange tool to push down alternate needles starting from the second needle on the left. e.g. 96 needles required altogether. Push up 48 needles each side of centre. Starting with number 47 left, push the alternate needles down again.

Now push up the in-between needles on the back bed, making sure that the outside needle on the right is on the back bed, and the outside needle on the left is on the front bed.

Handle up. Orange strippers. N/N Tension 2/2. Knit one row. CX/CX Tension 2¼/2¼. Knit two rows. N/N Tension 3/3. Knit one row.

### NECKBAND SUITABLE FOR V NECK GARMENTS.

Sizes 22 in (56 cm.) to 32in.(81 cm.) require 118 needles in 1 x 1 rib.

Sizes 34 in (86 cm.) to 44 in.(112 cm.) require 152 needles in 1 x 1 rib.

Handle up. Orange or blue strippers. N/N Tension 2½/2½. Knit 1 row.

CX/CX Tension 3½/3½ Knit 2 rows.

N/N Tension 4/4 Knit 10 rows.

Handle down.

Bring up the in between needles on both beds. N/N Tension 4/4. Knit 1 row.

N/GX, Black strippers. Tension 4. Knit 1 row.

Tension 5. Knit 1 row. Tension 6. Knit 1 row. Tension 7. Knit 1 row.

Pull down a length of yarn between the beds. Set the lock setting to GX/ N and repeat the last four rows increasing the tension on each row as before.

Change to waste yarn. Knit 4 rows. Change the lock setting to N/GX and knit 4 rows. Blue or orange strippers. N/N. Tension 5/5 Knit 2 rows and release from the machine.

Press the waste knitting and the last row of main knitting on each side of the neckband.

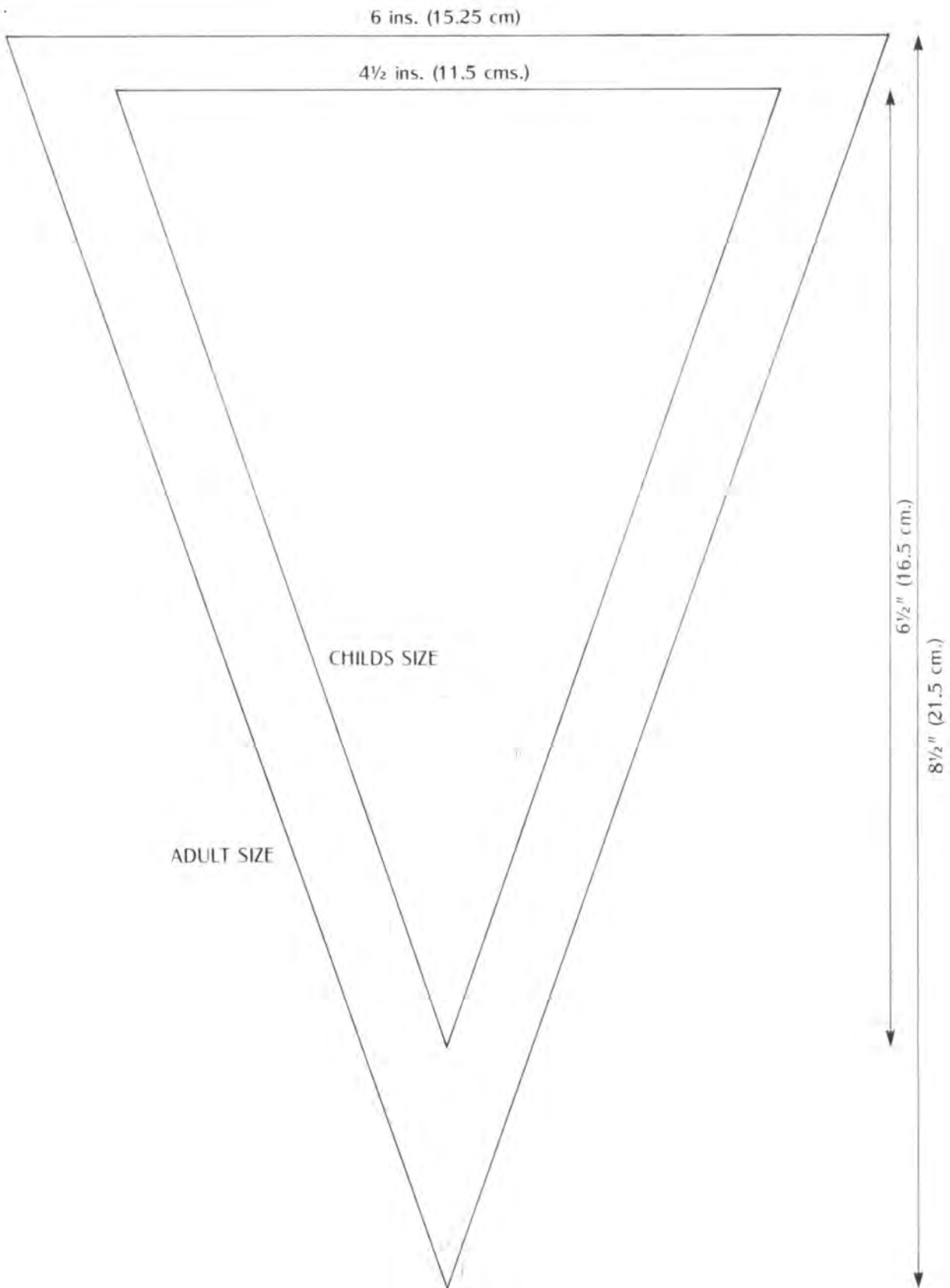

## TEMPLATES FOR CUT AND SEW V NECKLINE

Backstitch or machine stitch twice around the shape. The back neck may be hollowed out to ½ in. (1.5 cm.) at the centre to give a better fit on the back of the neckline. Cut out the fabric inside the stitching. Unravel the last two rows of waste yarn from the neckband. Pin one side of the stocking stitch part of the neckband to the right side of the garment, spreading the band evenly and having the edges meeting at the point of the V.

Thread up a fine tapestry needle with a length of the main yarn. Unravel all but the last row of waste knitting on the right side. Pull back the last row of waste knitting stitch by stitch and at the same time backstitch through the open loops of the last row of main knitting.

Turn to the inside of the garment. Unravel the waste yarn and catch down the last row of main knitting.

Mitre the V at the front and catch down the side edges of the rib.

## NECKBAND SUITABLE FOR ROUND NECK CUT AND SEW GARMENTS

When using 3 ply yarn, e.g. Ivette or 2 strands of 2/30, reduce each tension by one whole number.

Handle up.

SIZE 22 24 26 28 30 32 34 36 38 40 42 44 inches

(56 61 66 71 76 81 86 92 97 102 107 112) cms.

SET UP 110 114 120 130 132 134 136 138 140 142 144 146 needles for 1x1 rib

Orange or blue strippers. N/N. Tension 3/3. Knit 1 row.

CX/CX. Tension 4/4. Knit 3 rows.

N/N Tension 4/4 Knit 10 rows

N/N Tension 5/5 Knit 1 row

N/N Tension 4/4 Knit 10 rows

Handle down. Push up all the empty in-between needles on both beds.

N/N Tension 4/4 Knit 1 row

CX/CX Black Strippers. Tension 5/5 Knit 2 rows

GX/N Tension 6 Knit 5 rows.

N/GX Tension 6. Pull down a length of yarn under the bed before knitting 5 rows.

Change to waste yarn and knit 5 rows on each bed as you did with the main yarn.

N/N Tension 4/4. Knit 1 or 2 rows with waste yarn to close the knitting together. Release from the machine. Press the waste yarn and the last row of main knitting on each side of the neckband.

Sew up either the raglan seams or the shoulder seams of the garment. Sew the neck shape using either 2 rows of backstitching or 2 rows sewn with a machine. Use sharp scissors to cut out the neck shape, above the sewing line.

Pin one side of the stocking stitch over the neckline on the right side. Unravel all but the last row of waste yarn on that side. Thread a fine tapestry needle with the main yarn and slowly unravelling the last row of waste knitting, backstitch through the open loops of the main knitting, catching the fabric of the garment at the same time.

Turn the garment inside out. Unravel the waste yarn in the same way as on the front. Catch down the last row of main knitting, stitch by stitch on the inside. Fold the neckband to the inside and catch down.

## MEASUREMENTS

Approximate measurements of finished garments in inches.

Approximate measurement of finished garments in centimetres.

SIZE	Garment chest measurement	Top of rib to armhole	Armhole depth	Underarm seam	SIZE	Garment chest measurement	Top of rib to armhole	Armhole depth	Underarm seam
22	24	6.2	5.8	8	56	61	16	15	20
24	26	7	6.5	9	61	66	18	16.5	23
26	28	7.5	7	10	66	71	19	18	25.5
28	30	8.7	7.3	11.5	71	76	22	18.5	29
30	32	10	7.5	13	76	81	25	19	33
32	34	11.7	7.8	14	81	86	30	20	35.5
34	36	12.5	8.5	14.5	86	91	32	21.5	37
36	38	13	9.5	15	92	97	33	24	38
38	40	13	9.5	16	97	102	33	24	40.5
40	42	13.2	9.8	16	102	107	33.5	25	40.5
42	44	13.2	10	16.5	107	112	33.5	25.5	42
44	46	13.5	10.3	16.5	112	117	34.5	27	42

Please note that extra 'ease' has been allowed on the sideways knitted garments.



**TEMPLATES FOR CUT AND SEW ROUND NECKLINE**

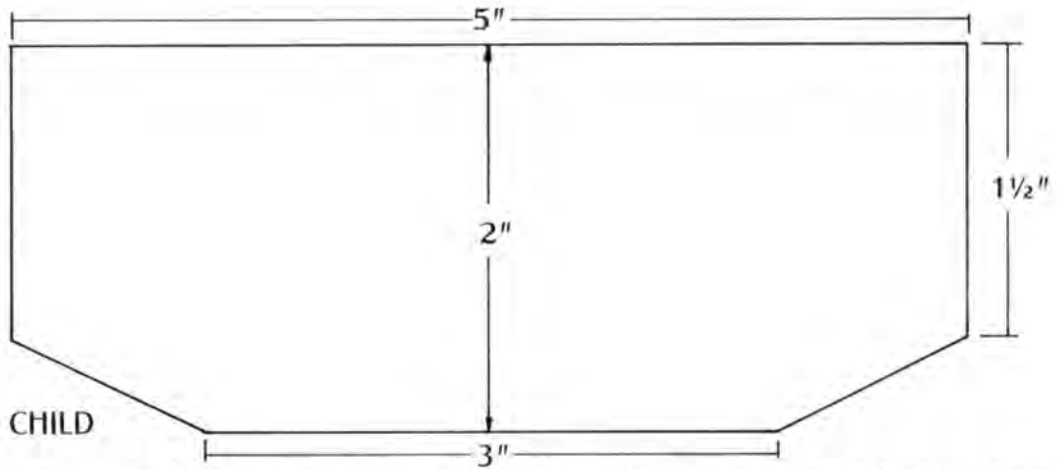
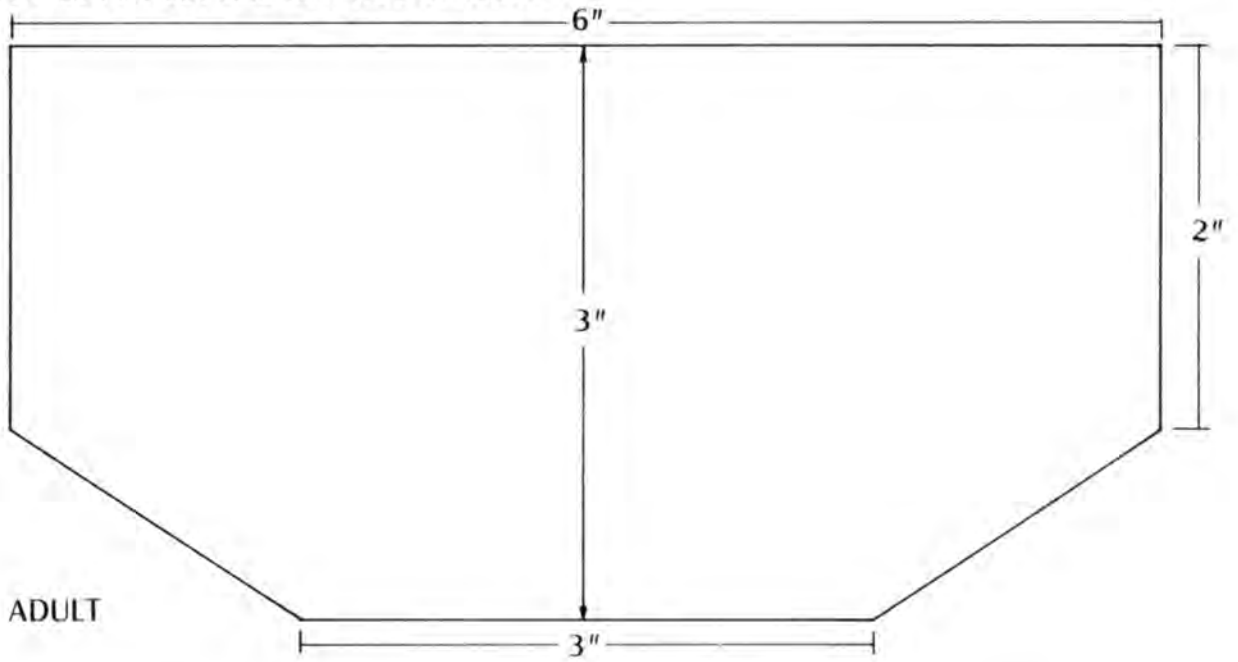

Use these templates as a guide for neckline shape but experiment with your own. Since children have large heads in relation to the rest of their bodies there is little difference between the child's and the adult's.





### Cut and Sew Neckline

If you choose to do a cut and sew neckline then omit the top ribs and knit an extra 16 rows of pattern. Join the shoulders and follow the instructions for either the round or the Vee neck cut and sew neckline at the beginning of the book.

### Roll collar

Use the measurements from the diagram for the round cut and sew neck. Backstitch twice around the neckline in the normal way and make the following collar:-

Arrange 76 needles on each bed for an every needle rib cast on.

Handle down. Blue or orange strippers. Tension  $2\frac{1}{2}/2\frac{1}{2}$ . Knit one row.

CX/CX Tension  $3\frac{1}{4}/3\frac{1}{4}$ . Knit two rows.

N/N Tension  $3\frac{1}{2}/3\frac{1}{2}$ . Knit one row.

Bring out a pusher for every working needle on the front bed. Arrange in a two up, two down pattern (or in the pattern you have chosen for your garment).

N/AX left arrow key on the front bed.

Tension  $3\frac{1}{4}/3\frac{1}{4}$  Knit 30 rows.

" 4/4 "

"  $4\frac{1}{4}/4\frac{1}{4}$  "

" 4/4 "

"  $3\frac{3}{4}/3\frac{3}{4}$  "

Cast off loosely.

Sew the side edges of the collar together to make a circle. Sew the cast off edge to the right side of the neckline putting the right side of the collar to the right side of the garment. Fold the collar in half with the right side showing and catch down the cast on edge to the inside of the neckline, enclosing the cut edge.

### Cowl collar.

Use the cowl collar as given on the pattern for the One Size Sweater in Astrakan but use the pusher pattern which you have chosen and the lock setting N/AX with the left arrow key on the front bed.

There are so many ideas to use, and so many combinations of these ideas, that you can very quickly make a wardrobe of tops and sweaters, each one looking different.



## TUCK STITCH TOP IN 2 STRANDS OF 2/30 OR 1 STRAND OF IVETTE

Tension 63 rows, 16 stitches = 4 inches (10 cms.) Tension dials approximately 4½/4½.

SIZE 22in (56cms.)

20 ROWS E/N Rib T4/4
76 ROWS
-----
98 ROWS
20 ROWS E/N Rib T3/3

CAST ON 50 STS.  
SIZE 28in (71cms.)

20 ROWS E/N Rib T4/4
100 ROWS
-----
138 ROWS
20 ROWS E/N Rib T3/3

CAST ON 62 STS.  
SIZE 34in (86cms.)

20 ROWS E/N Rib T4/4
118 ROWS
-----
196 ROWS
30 ROWS E/N Rib T3/3

CAST ON 74 STS.  
SIZE 40in (102cms.)

20 ROWS E/N Rib T4/4
138 ROWS
-----
208 ROWS
30 ROWS E/N Rib T3/3

CAST ON 86 STS.

SIZE 24in (61cms.)

20 ROWS E/N RIB T4/4
86 ROWS
-----
110 ROWS
20 ROWS E/N RIB T3/3

CAST ON 54 STS.  
SIZE 30in (76cms.)

20 ROWS E/N RIB T4/4
102 ROWS
-----
158 ROWS
20 ROWS E/N RIB T3/3

CAST ON 66 STS.  
SIZE 36in (92cms.)

20 ROWS E/N RIB T4/4
134 ROWS
-----
204 ROWS
30 ROWS E/N RIB T3/3

CAST ON 78 STS.  
SIZE 42in (107cms.)

20 ROWS E/N RIB T4/4
142 ROWS
-----
208 ROWS
30 ROWS E/N RIB T3/3

CAST ON 90 STS.

SIZE 26in (66cms.)

20 ROWS E/N RIB T4/4
94 ROWS
-----
118 ROWS
20 ROWS E/N RIB T3/3

CAST ON 58 STS.  
SIZE 32in (81cms.)

20 ROWS E/N RIB T4/4
108 ROWS
-----
184 ROWS
20 ROWS E/N RIB T3/3

CAST ON 70 STS.  
SIZE 38in (97cms.)

20 ROWS E/N RIB T4/4
134 ROWS
-----
204 ROWS
30 ROWS E/N RIB T3/3

CAST ON 82 STS.  
SIZE 44in (112cms.)

20 ROWS E/N RIB T4/4
146 ROWS
-----
212 ROWS
30 ROWS E/N RIB T3/3

CAST ON 94 STS.



## SLEEVES TO FIT IN THE TUCK STITCH TOP

Tension 63 Rows, 16 stitches = 4 inches (10 cms.) Tension Dials Approximately 4½/4½

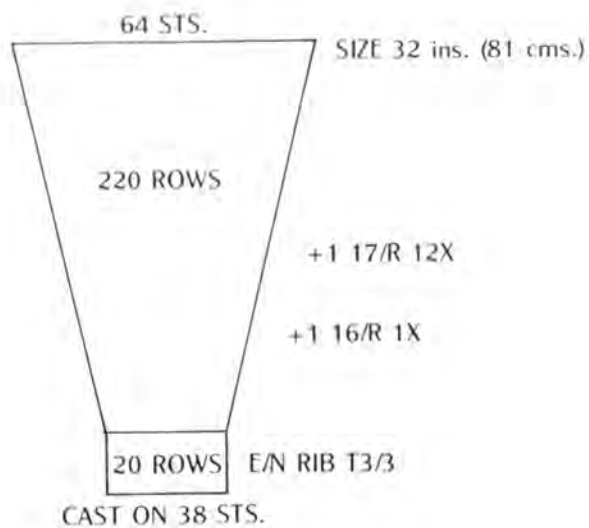
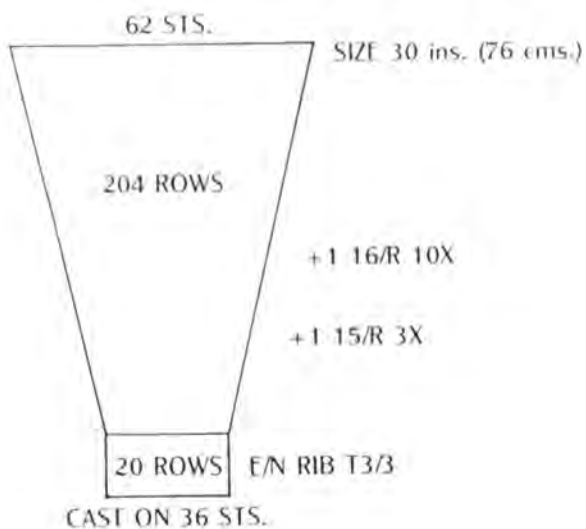
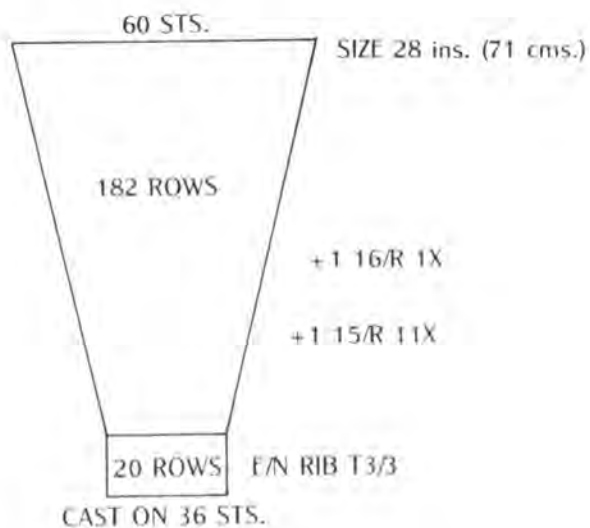
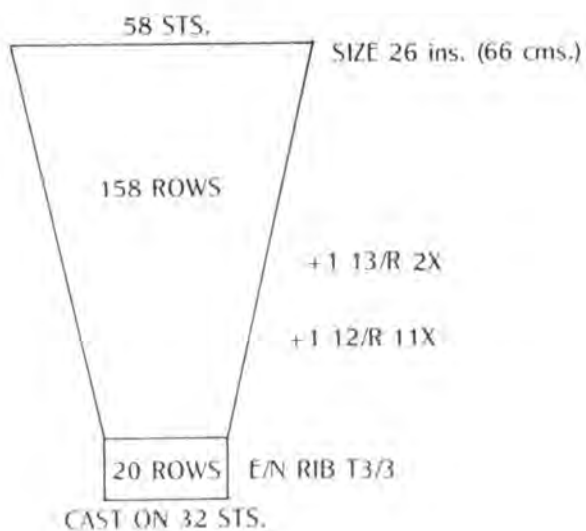
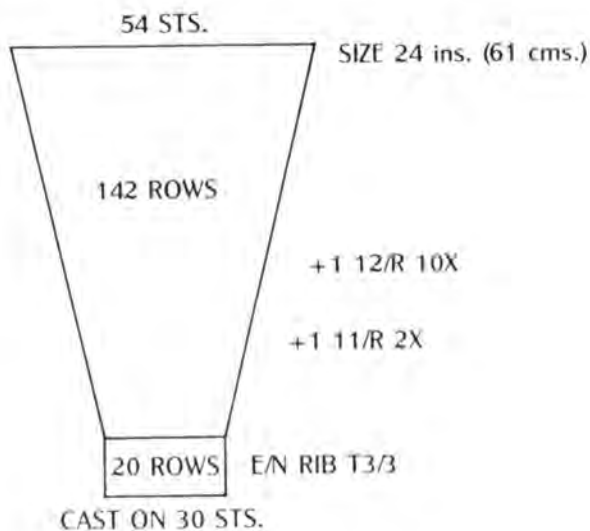
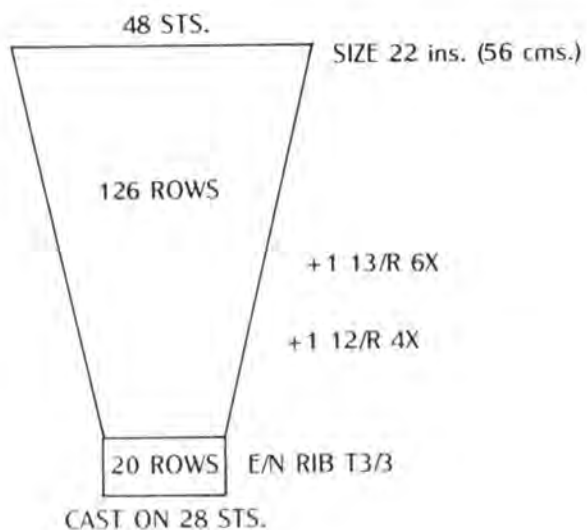

## SLEEVES TO FIT IN THE TUCK STITCH TOP

Tension 63 Rows, 16 stitches = 4 inches (10 cms.) Tension Dials Approximately 4½/4½

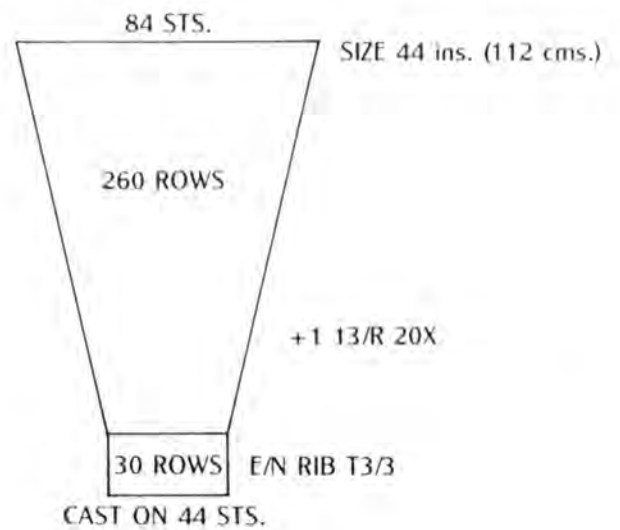
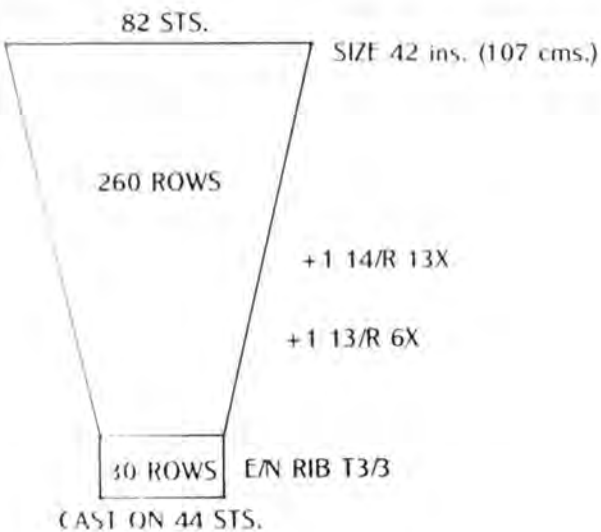
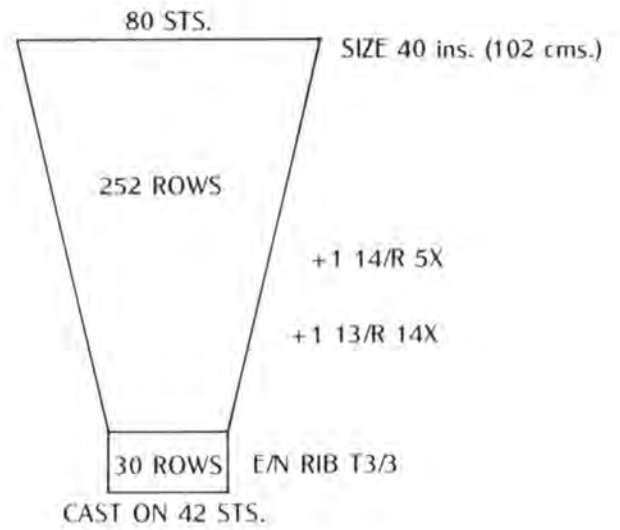
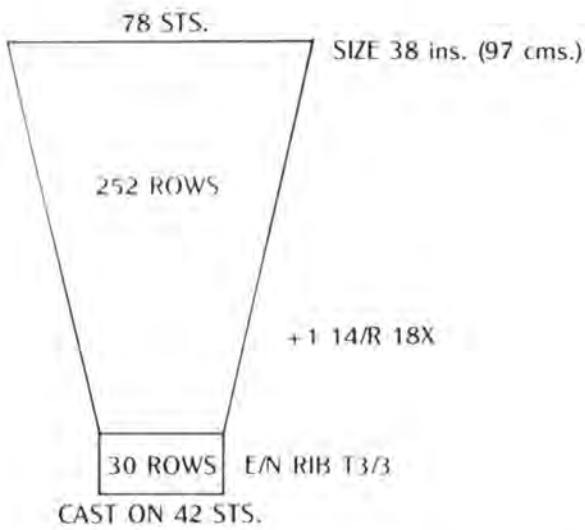
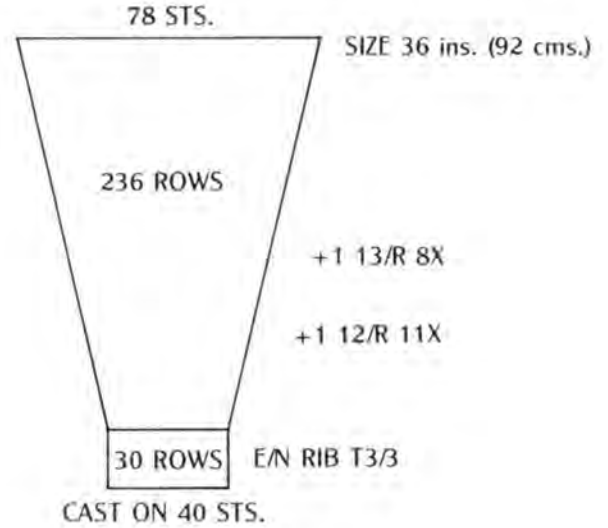
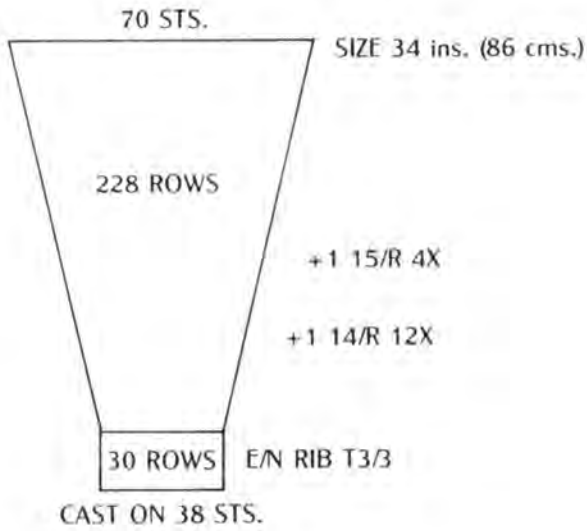



## QUICK AND EASY HALF-FISHERMAN'S RIB JACKET IN 4 PLY.

Knitted in Bramwell's Fine 4 Ply in three sizes - Small 32in - 34in (81 cm.-86 cm.), Medium 36 in - 38 in. (92 cm. -97 cm.), Large 40 in- 42 in. (102 cm.- 107 cm.), Tension 28.8 sts., 61.6 rows = 4 ins. (10 cm.) Tension Dials approx 4½/4½. 100 sts = 13.9 ins (35.3 cm.) 100 rows = 6½ ins (16.5 cms.)

The half fisherman's rib is knitted on a 1x1 needle arrangement therefore the stitches are counted on both beds.

### Back

Handle up. Blue or orange strippers. Cast on the required number of stitches and knit 10 rows in 1 x 1 rib at tension 3 /3.

R.C. 000 N/EX Tension 4½/4½.

Knit the number of rows shown for the first section.

R.C. 000 Decrease one stitch at each end of the knitting

on every row 16 times by moving the outer stitch to the next working needle on the opposite bed. Complete the number of rows for the second section. Cast off for the shoulder shaping according to the diagram, by moving the stitches on to one bed at the same side as the locks and casting off the number shown. When only 44 stitches are left in work knit one row and cast off.

### Right Front.

The diagram for the right front is shown. This piece contains the buttonholes. When the fabric is on the machine the wrong side is facing the knitter, therefore the buttonholes will be made on the left hand side of the knitting. When setting up the needles for the 1 x 1 rib use 30 to the left of the centre and the rest to the right of centre.

### Buttonholes.

To be made on row 10 of the 1 x1 rib. Change the Row Counter to 000 then work the buttonholes on rows 27, 53 and 79 of the half fisherman's rib.

Transfer the stitch from needle number 4 on the left side of the front bed onto the needle to its right on the back bed. (This needle now holds two stitches). Go to the needle to the left of this one, take the stitch from it and put the stitch onto the working needle to the left of the empty needle on the front bed. (needle number 6). That needle will now have two stitches. Put the two empty needles into work.

Now repeat the process with needle number 24 on the front bed.

Knit the first and second sections according to the diagram.

R.C.000. Shape the shoulder. When this has been done 30 stitches will be left on the machine. Continue to knit to row 46. Cast off.

### Left Front

Reverse the shaping and omit the buttonholes.

### Sleeves

Cast on and knit the required number of stitches in 1 x 1 rib for 30 rows at tension 3/3.

R.C. 000 N /EX Tension 4½/4½. Knit the required number of rows increasing one stitch, at each end of the knitting, every six rows. Increase by putting the next needle into work, remembering to keep to the 1 x 1 needle setting. You may find when the next needle to be increased at the left hand side is on the front bed, that this needle will not automatically make a stitch. In this case pick up a loop from below the last stitch on the left and place it on the empty needle. Knit the sleeve according to the diagram.

### Making up.

Join the shoulder seams. Join the two cast off edges of the front bands with a flat seam. When this has been done join the side edges of the ribbing to the back neck. Insert the sleeves. Join the underarm and side seams. Sew on the eight buttons.



# QUICK AND EASY HALF-FISHERMAN'S RIB JACKET IN 4 PLY

Tension 28.8 stitches, 61.6 rows = 4 ins. (10 cms.) Tension Dials approximately 4½/4½

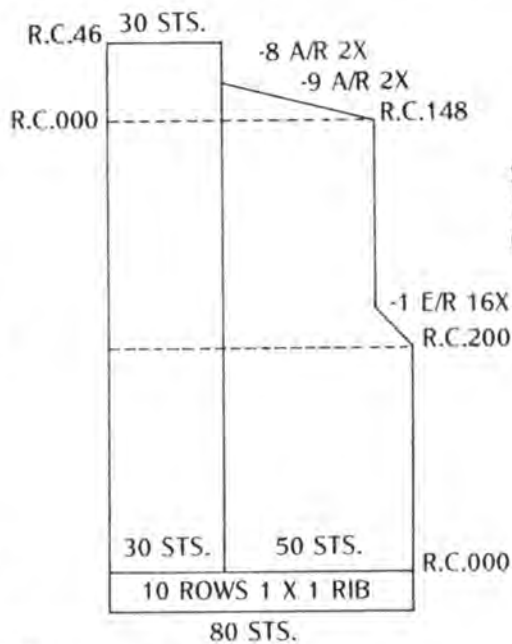
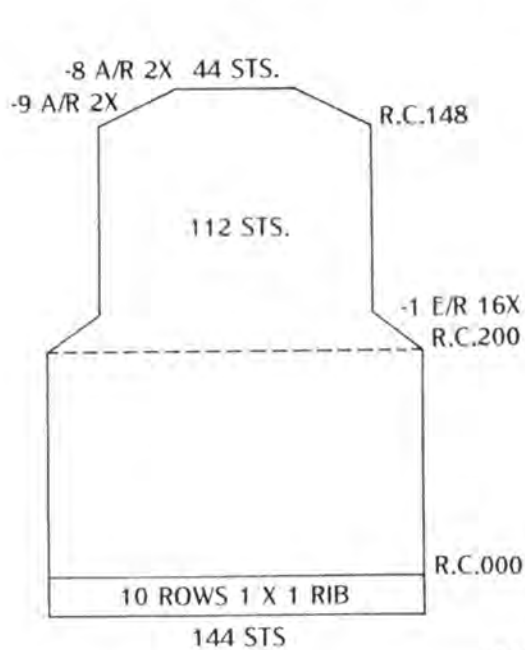

SMALL SIZES  
32 and 34 ins.  
(81 and 86 cms.)

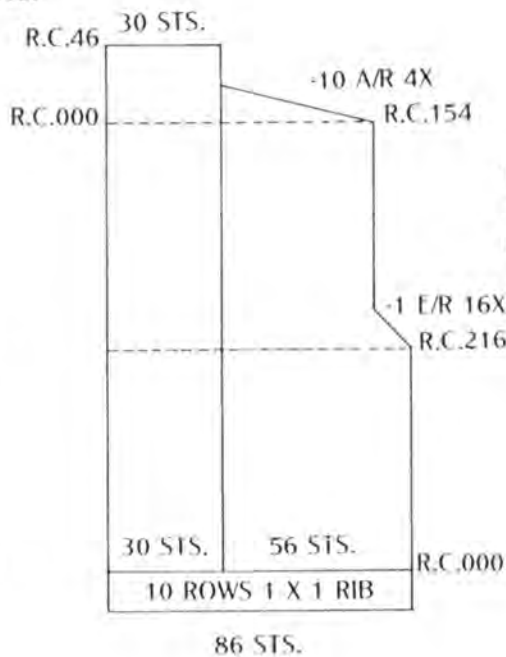
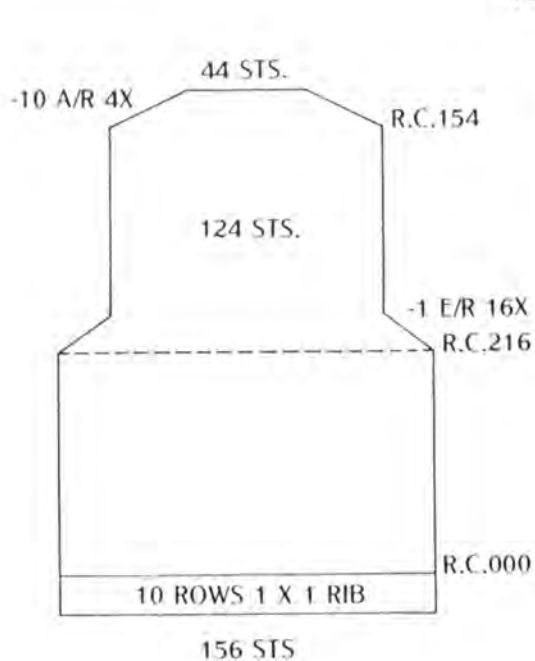
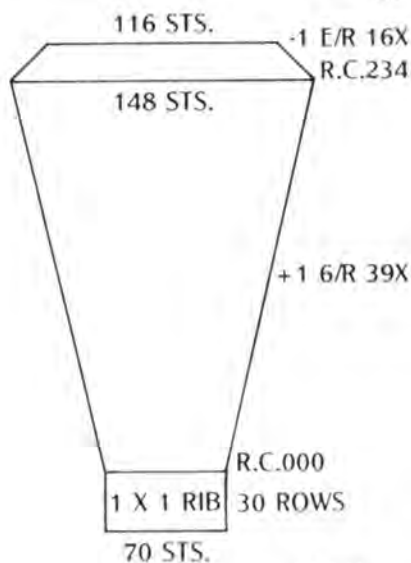

MEDIUM SIZES  
36 and 38 ins.  
(92 and 97 cms.)



# QUICK AND EASY HALF-FISHERMAN'S RIB JACKET IN 4 PLY

Tension 28.8 stitches, 61.6 rows = 4 ins. (10 cms.) Tension Dials approximately 4½/4½

MEDIUM

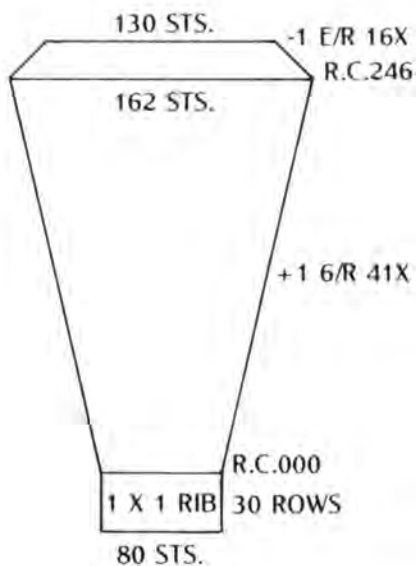
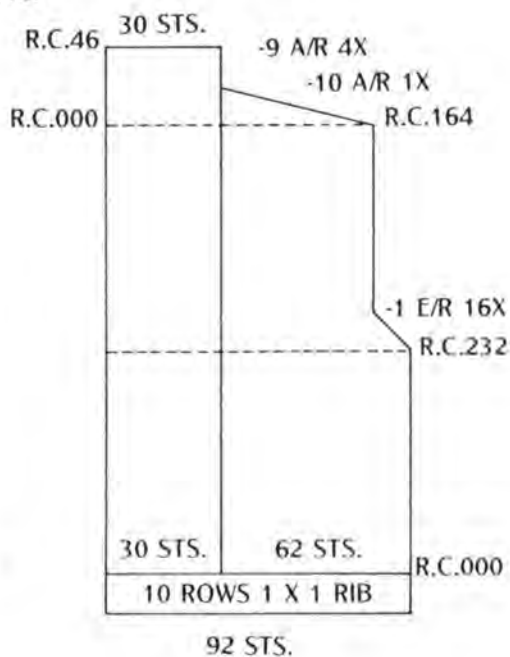
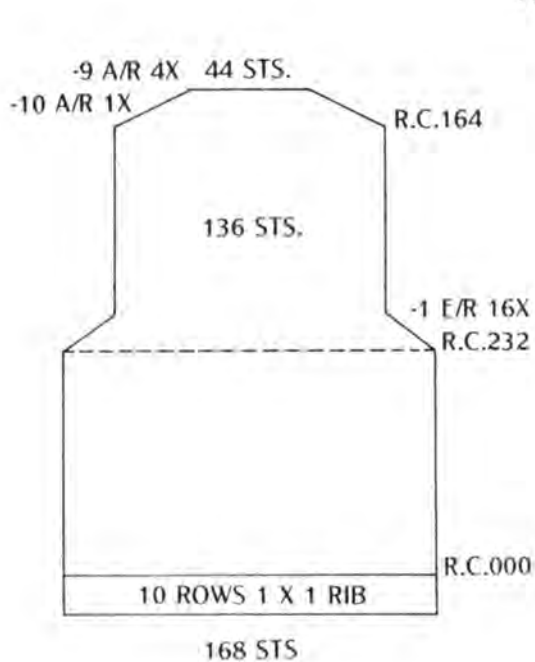
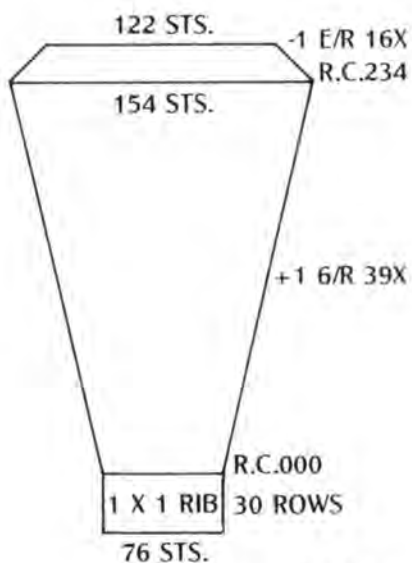

LARGE SIZES  
40 and 42 ins.  
(102 and 107 cms.)

## ZODIAC SKIRT WITH SIDEWAYS KNITTED PLEATS.

### Tension Piece

Black strippers. Handle down. Cast on 50 stitches, on the front bed only, in waste yarn. Knit several rows until all the needles are knitting satisfactorily.

R.C. 000. Tension Dial approximately 6. Pushers in a 1 up, 1 down position. The back lock should be set to GX throughout.

Pattern for pleats.

20 rows N, 2 rows AX, 10 rows N, 2 rows BX

Leave the left arrow key pushed in throughout.

There are 34 rows in each pleat. Knit 3 pleats then run off on several rows of waste yarn.

Pull the knitting across the stitches instead of lengthwise as is customary. Tack down along each pleat. Cover with a damp cloth and press with a cool iron.

The 50 stitches should measure 7.2 inches (18.3 cm.) and the three pleats should measure 3 inches (7.6 cm.).

7 stitches = 1 inch (2.5 cm.). 1 pleat = 1 inch (2.5 cm.).

The skirt has a saddle around the hips which is approximately 4 inches deep, therefore if you require a skirt of 27 inches ( 68.5 cm ) then the pleated section should measure 27 inches - 4 inches = 23 inches. Remember to subtract 4 inches before deciding the length needed for the pleated section

### Number of stitches for the pleated section:-

Length

(in) 18.0 19.0 20.0 21.0 22.0 23.0 24.0 25.0

(cm) 45.7 48.3 50.8 53.3 55.9 58.4 61.0 63.5

Needles

126 133 140 147 154 161 168 175

Each pleat should measure 1 inch (2.5 cm.) If the hip measurement required is 38 inches (96.5 cm.) then 38 pleats will be required. No allowance for ease is needed. Knit in pattern for the number of pleats required but omit the last two rows of the very last pleat.

There are 34 rows for each pleat. I include a ready reckoner so that if you are called away from the machine you can easily calculate where you are up to when you return.

No.	Rows	No.	Rows	No.	Rows	No.	Rows	No.	Rows
1	34	11	374	21	714	31	1054	41	1394
2	68	12	408	22	748	32	1088	42	1428
3	102	13	442	23	782	33	1122	43	1462
4	136	14	476	24	816	34	1156	44	1496
5	170	15	510	25	850	35	1190	45	1530
6	204	16	544	26	884	36	1224	46	1564
7	238	17	578	27	918	37	1258	47	1598
8	272	18	612	28	952	38	1292	48	1632
9	306	19	646	29	986	39	1326	49	1666
10	340	20	680	30	1020	40	1360	50	1700

When the number of rows required have been completed, transfer the stitches to the back bed. Pick up the beginning of the knitting (take care not to twist the fabric) and place the stitches from the first row of main yarn onto the needles already holding stitches. Allow the first stitch on the needle to slide behind the latch and pull the second stitch through it, all the way across the knitting. Knit 1 row at Tension 7 and cast off loosely.

Tack down each pleat. Pull the fabric over the end of the ironing board. Use a damp cloth and a cool iron. Press carefully. Hang from the top to dry.





### Waistband and top of skirt

This is knitted from the waistband downwards

Hip size inches	30	31	32	33	34	35	36	37	38	39	40
Hip size cm	76	79	81	84	87	89	92	94	96	99	102
No of Needles	102	106	108	112	116	120	122	126	130	132	136
Hip size inches	41	42	43	44	45	46	47	48	49	50	
Hip size cm	104	107	109	112	115	117	119	122	124	127	
No of needles	140	142	146	150	154	156	160	164	166	170	

Handle up. Set up the required number of needles for 1 x 1 rib.

Blue or orange strippers. N/N Tension 2½/2½ Knit 1 row.

GX/N Tension 4 Knit 1 row.

Black strippers. GX/N Tension 5 Knit 19 rows.

Blue or orange strippers. N/N Tension 4/4, Knit 50 rows.

Transfer the stitches to the front bed. Black strippers. GX/N. Tension 6 on the front bed. Knit 1 row. Change to waste yarn and knit several rows. Release from the machine.

Knit a second identical piece. Press the waste yarn and the last row of main knitting. Join the side seams. Place the saddle over the top of the pleats and back stitch through the last row of main knitting making sure you are sewing right through the pleats. Remove the waste yarn and tacking threads. Thread 1 inch (2.5 cm.) elastic through the waistband.

This skirt may be matched with the half fishermans rib jacket, knitted in Zodiac to make a smart and easy to wear suit.

## TWO OR THREE COLOUR TUCK WAISTCOAT

Knitted in Bramwell Fine 4 ply, on the front bed. Using the self punched Deco card.

Tension 56 rows, 24 stitches = 4 ins.(10 cm.). Tension dial approximately  $6\frac{3}{4}$ . 100 rows = 7.14 ins (18 cm) 100 sts. = 16.7 ins (42 cm)

This stitch gives an interesting combination of texture and colour but it must be knitted on perfect needles at a slow speed. Weighting the bottom of the fabric is also an advantage. There is only a little shaping so that remembering to change colour every four rows is not a great problem. It can be knitted in one, two or three colours to give different effects.

If you wish to wear the waistcoat unfastened it is advisable to knit the ribs on tension 5/5 so that the ribs do not pull the fronts to the side of the body.

### Back

Handle up. Blue or orange strippers.

Cast on the required number of stitches and knit, with the main yarn, the number of stitches shown on the diagram. Knit the 1 x 1 ribs ending with the locks on the left of the machine. Transfer the stitches to the front bed.

Handle down. Black strippers. GX/N Tension  $6\frac{3}{4}$ . Knit one row in the same colour as the ribs. Change to first contrast yarn. Bring up a pusher for every working needle.

Move the row tripper to the left of the knitting.

GX/AX no arrow keys. Pass the card reader three times across the card and attach to the lock. Set the Deco to 2. Knit 4 rows first contrast, 4 rows second contrast, 4 rows main colour throughout. Knit the first section.

R.C. 000. Cast off the required number of stitches for the armhole at the beginning of the next two rows. Remember to return the pushers to the rail. Knit the second section keeping to the correct colour sequence. Cast off for the shoulders according to the diagram. It will be necessary to pull down the yarns between the beds before knitting with them if they have not been used for the cast off. These loops can be cut and sewn in when the garment is removed from the machine.

When only the number of stitches shown for the back neck is left in work, cast off loosely. Turn the Deco card back to 0.

### Fronts.

Work as for the back up to the neck shaping. Shape the neck and work until the number of rows for the second section have been completed. Shape the shoulder. Work the second front with reversed shaping. Join the front shoulders to the back.

### Ribs

Number of stitches required.

Size	Armhole rib (10 rows)	Neck (10 rows)	Front (10 rows)
	Tension	4/4	5/5
22	72	72	78
24	80	80	88
26	86	86	94
28	90	90	100
30	92	92	108
32	96	96	120
	(20 rows)	(10 rows)	(10 rows)
34	104	104	130
36	116	116	138
38	116	116	138
40	120	120	142
42	122	122	144
44	126	126	148





## Buttonholes

To be made on the fifth row of the front band. Make the buttonholes on the following needles, counting the stitches on the front bed only from the left hand side.

Size	Stitch Numbers						
22	3	9	15	21	27	33	37
24	3	10	17	24	31	37	43
26	3	10	17	24	31	38	45
28	3	11	19	27	35	42	49
30	3	11	19	27	35	43	52
32	3	11	19	27	35	43	59
34	3	11	19	28	37	46	63
36	3	12	21	30	39	48	67
38	3	12	21	30	39	48	67
40	3	12	21	30	39	49	69
42	3	12	21	30	40	50	70
44	3	13	23	33	43	53	72

Transfer the stitch onto the needle to its right on the back bed (this needle now holds two stitches). Go to the needle to the left of this one, take the stitch from it and put the stitch onto the working needle to the left of the empty needle on the front bed. That needle will now have two stitches. Put the two empty needles into work.

Work the 1 x 1 ribs. Transfer the stitches to one bed. Knit one row at main tension. (Black strippers) and run off on several rows of waste yarn. Press the waste knitting and the last row of main knitting. Pin the neck rib into place on the right side of the garment and remove all but the last row of waste yarn. Thread a tapestry needle with main yarn. Remove the last row of waste knitting stitch by stitch at the same time backstitch through the open loops of the main knitting. This is a rather long method of attaching the ribs but I did not find a satisfactory method of joining them on the machine because of the loops at the colour changer side of the knitting. However, hand stitching the ribs gives a very neat finish to the garment. When the neck rib has been sewn on, attach the front and armhole ribs by the same method.

Join the side seams. Lay the garment under a damp cloth to dry.

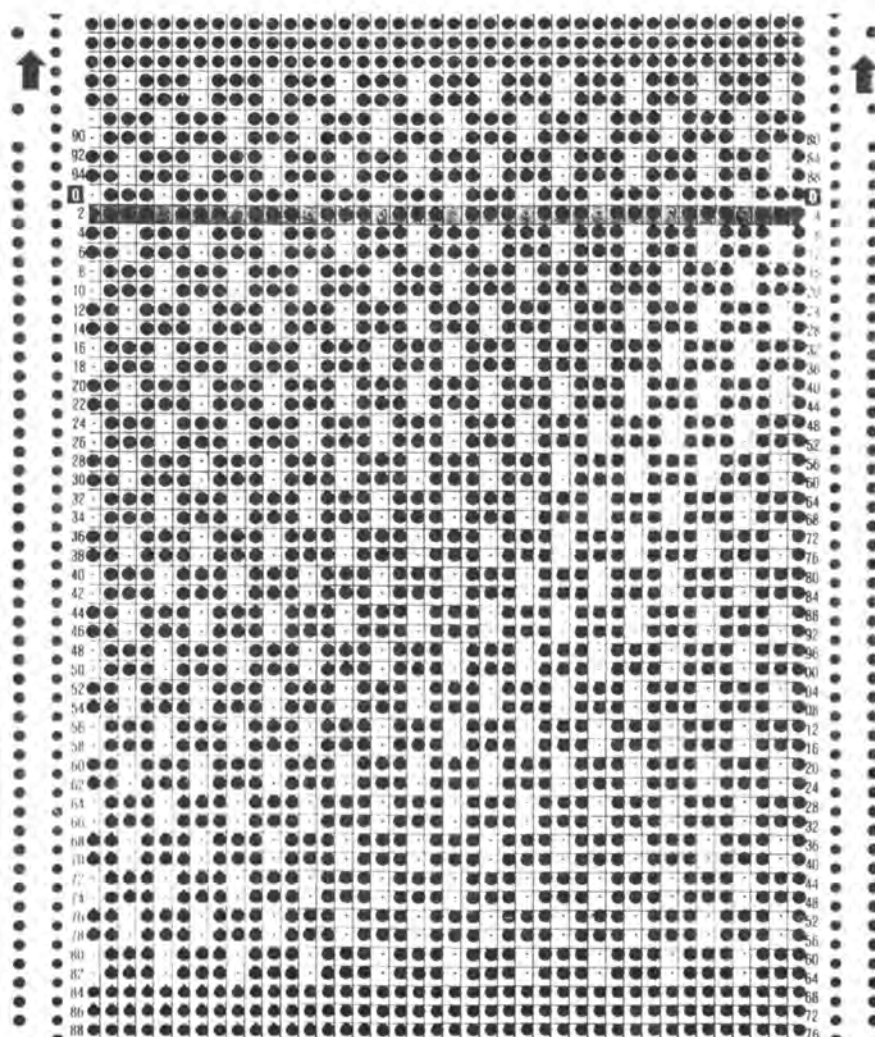

## TWO OR THREE COLOUR TUCK WAISTCOAT

Tension 24 stitches, 56 rows = 4 ins. (10 cms.) Tension Dial approximately 6 3/4

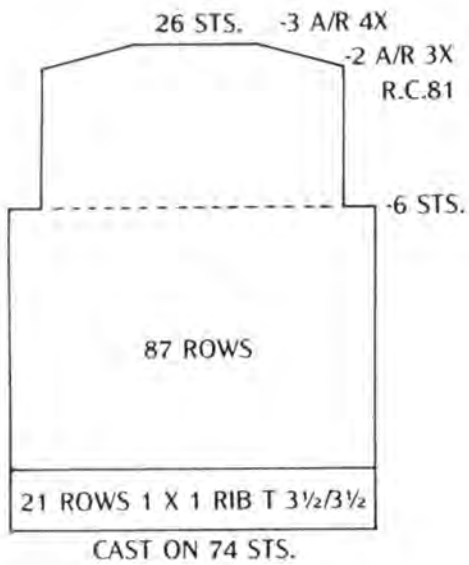

SIZE 22 ins. (56 cms.)

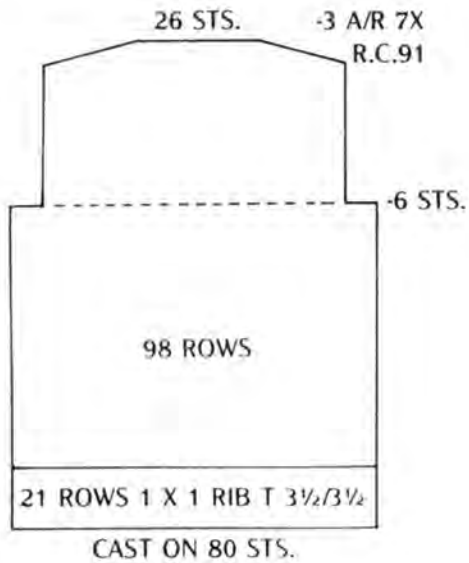

SIZE 24 ins. (61 cms.)

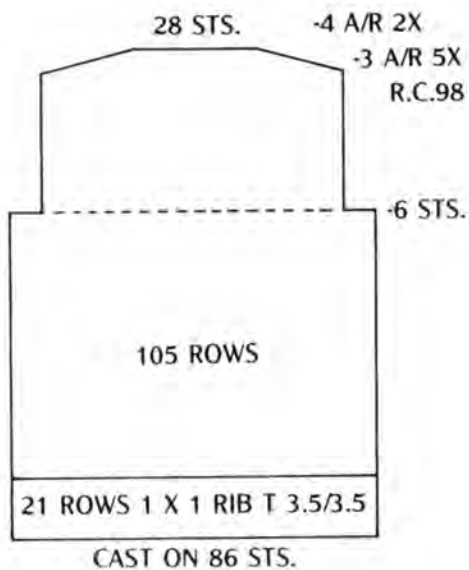

SIZE 26 ins. (66 cms.)

## TWO OR THREE COLOUR TUCK WAISTCOAT

Tension 24 stitches, 56 rows = 4 ins. (10 cms.) Tension Dial approximately 6¼

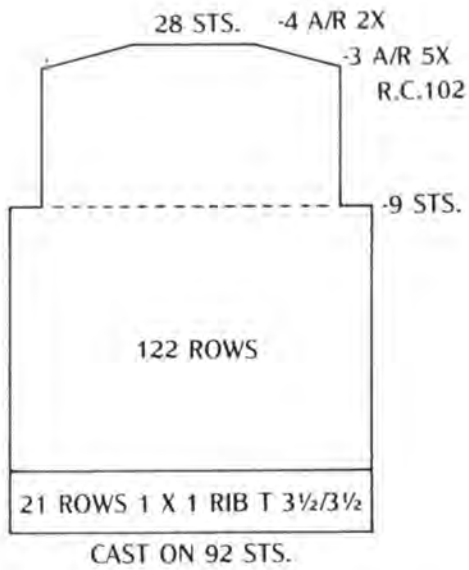

SIZE 28 ins. (71 cms.)

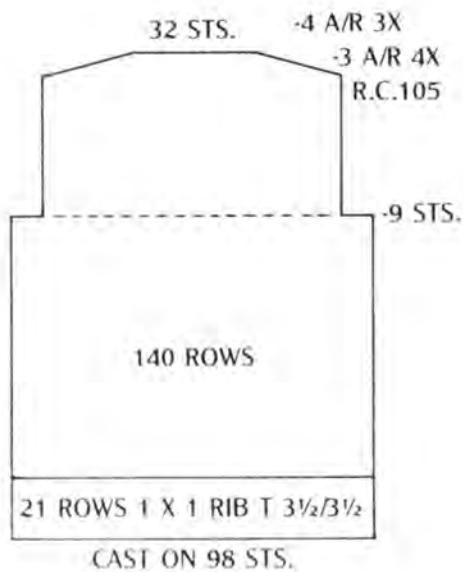

SIZE 30 ins. (76 cms.)

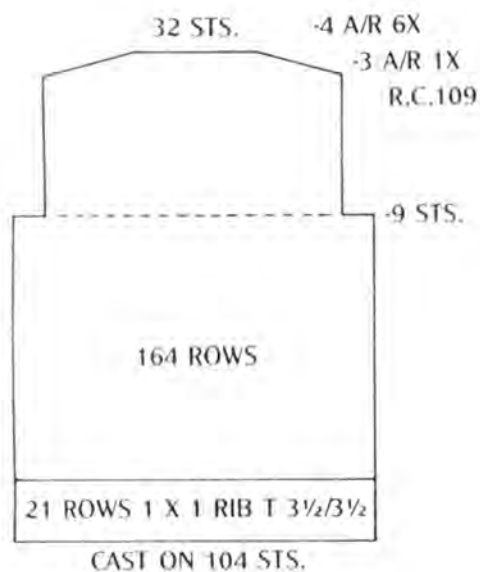

SIZE 32 ins. (81 cms.)



## TWO OR THREE COLOUR TUCK WAISTCOAT

Tension 24 stitches, 56 rows = 4 ins.(10 cms.) Tension Dial approximately 6¾

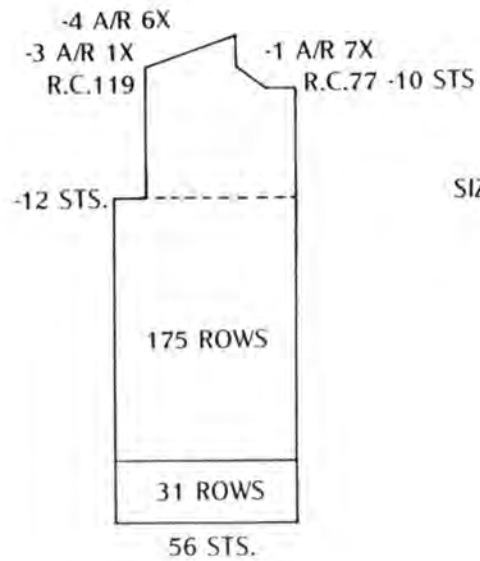
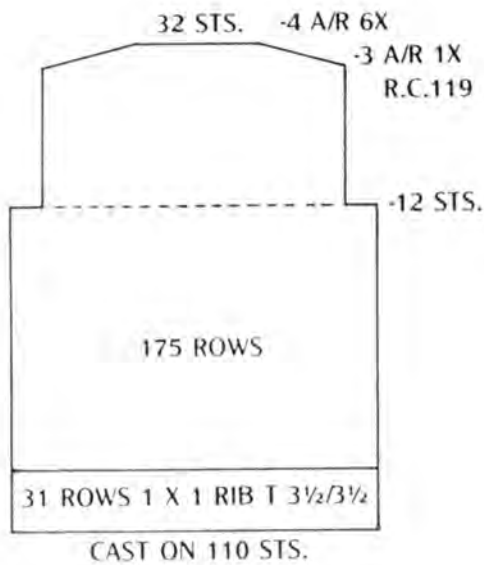

SIZE 34 ins. (86 cms.)

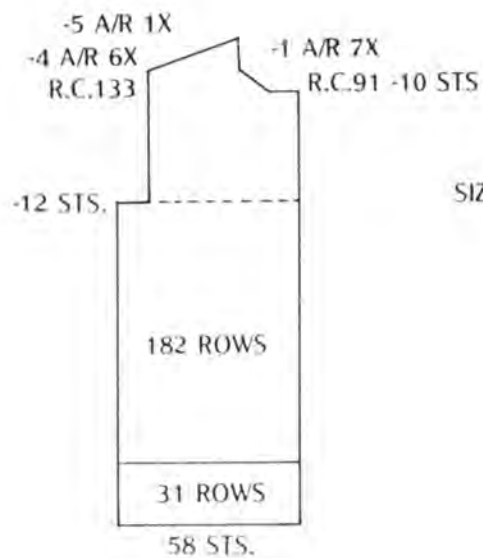
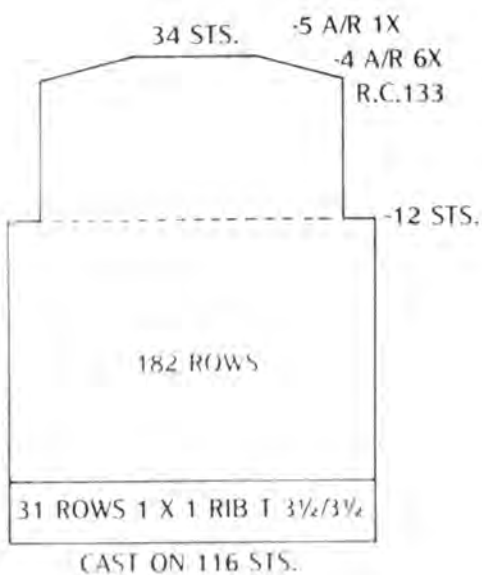

SIZE 36 ins. (92 cms.)

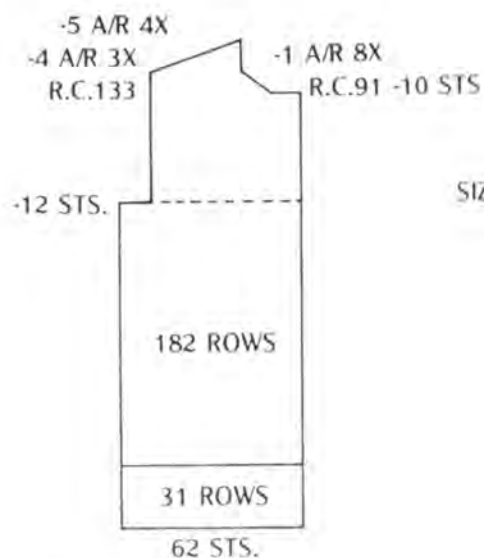
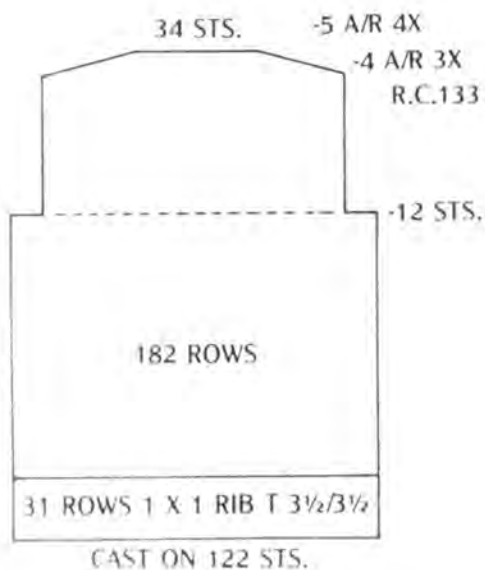

SIZE 38 ins. (97 cms.)

## TWO OR THREE COLOUR TUCK WAISTCOAT

Tension 24 stitches, 56 rows = 4 ins.(10 cms.) Tension Dial approximately 6¼

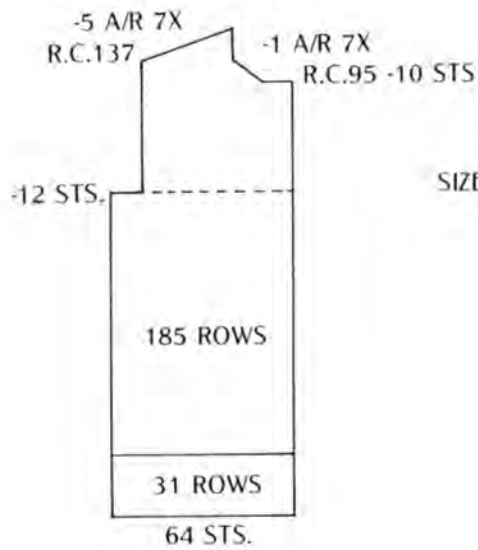
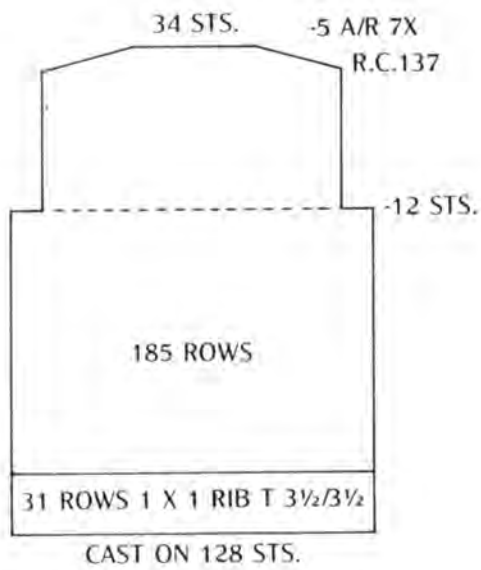

SIZE 40 ins. (102 cms.)

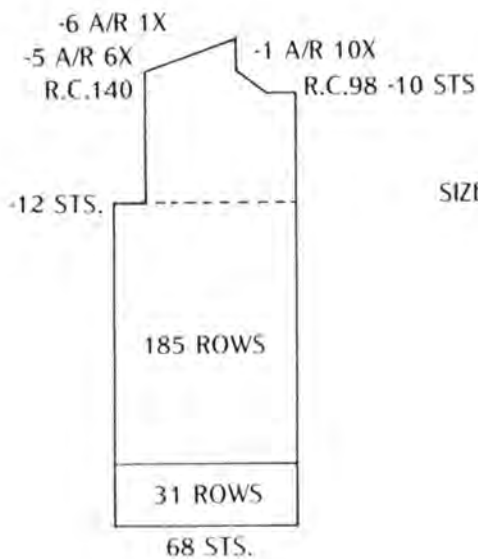
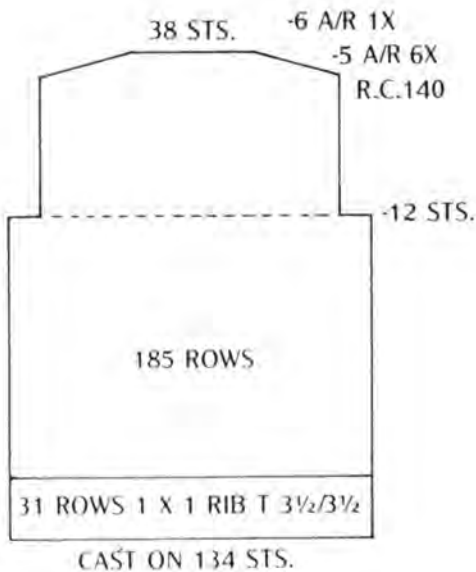

SIZE 42 ins. (107 cms.)

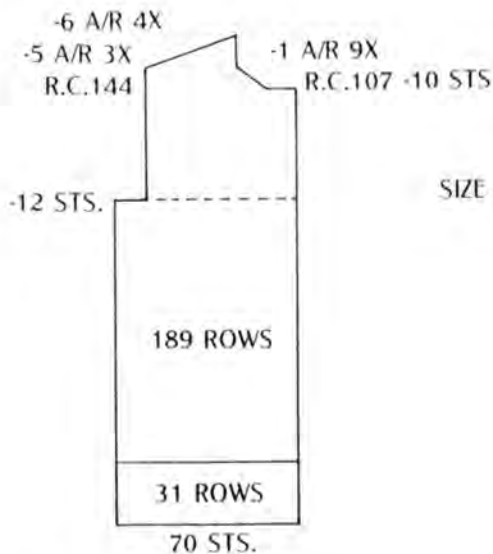
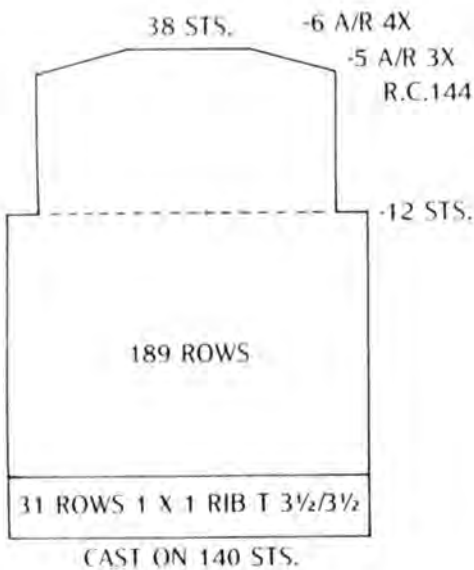

SIZE 44 ins. (112 cms.)

## STOCKING STITCH SWEATER WITH ROUND NECK AND CUT IN SLEEVES IN 4 PLY.

Tension approximately 6½ for Bramwell Fine 4 ply or 6¼ for 2 strands Hobby Knop Yarn knitted in single bed stocking stitch, 28 stitches, 40 rows = 4ins. (10 cm.). 100 sts. = 14.3 ins (36.3 cm.) 100 rows = 10 ins. (25.4 cm.)

### Back

Cast on in 1 x 1 rib and knit the number of rows required at Tension 3½/3½. Transfer the stitches to the front bed. Handle down. Black strippers. GX/N. Tension 6½. Knit the first section of stocking stitch.

RC 000. Cast off the number of stitches shown, at the beginning of the next two rows. Knit the second section of stocking stitch ignoring the neck shaping which is for the front piece.

### Shaping the shoulders.

**EITHER :-** Cast off the number of stitches shown on the diagram at the same side of the lock. Knit across to the other side and cast off the same number of stitches. The cast off is made on the same side as the lock on each row. Continue to knit according to the diagram until only the back neck stitches are left. Run off on several rows of waste yarn.  
**OR :-** Using hold position. Change the front lock to BX ( no arrow keys ). Bring up a pusher for every working needle. At the opposite end to the locks, put the number of needles shown plus one extra one into hold position by putting their pushers to rest position. Knit across, now bring the extra needle back into work by putting its pusher back up. Put the needles at the opposite side to the lock into hold (not forgetting the extra one) and continue to shape in this way until all but the back neck stitches are in hold, run these off on waste yarn. Put the pushers for the back neck stitches back into the blocking rail and the needles out of work. Put the pushers for one shoulder back into working position. Knit one row in main yarn on these stitches and then run off on several rows of waste yarn. Put the pushers for these needles back into the blocking rail and the needles out of work. Repeat the process for the other shoulder

### Front

Work in the same way as for the back until the correct row number for the neck shaping. Cast off the centre number of stitches for the neck. Using a ravel cord or a piece of smooth crochet thread, knit through the stitches on the opposite side to the locks. The stitches must be very long as the needles must be right out of work. Make sure there are no pushers in working position under these needles. Put a piece of sticky tape across the needle bed just over the needle butts. This is a safety measure to prevent the needles from knitting. ( It is not strictly necessary but the tip may help inexperienced knitters.) Now continue to knit on the side nearest to the locks, decreasing one stitch on alternate rows at the neck edge for the number of times shown on the diagram. When the decreasing has been completed knit until the correct row for the shoulder shaping. Shape the shoulder in the same way as the back. If you have used the holding position method of shaping make sure that all pushers have been put back into the blocking rail and the front lock reset to N. Remove the sticky tape from the needle bed. Holding both ends of the cord, gently pull to tighten it up. Allow one stitch at a time to fall back onto the needles. Return the row counter to the row number for the beginning of the neck shaping and thread the machine with the main yarn. Complete the second side of the neck and shoulder, reversing the shaping.

### Sleeves

Make the ribs in the same way as for the back and front pieces. Transfer the stitches to the front bed. R.C. 000. Handle down. Black strippers. GX/N Tension 6½.

Increase as shown on the diagram. To increase simply put an extra needle in work at both ends of the bed, the machine will do the rest. If you wish to do a fully fashioned increase then move three needles out by one position and fill the empty fourth needle with a loop from below the next stitch. Knit the number of rows required for the first section of the sleeve, increasing according to the diagram as you do so. When the first section has been knitted the shaping should be complete. Mark both end needles with a length of contrast yarn. Knit the second section without shaping. Cast off loosely. When making up, the side edges of the second section of the sleeve (from the marker to the cast off) are joined to the cast off sections of the armhole on the back and front pieces.





Join one shoulder seam. If the shoulder stitches were placed in holding position then they may be grafted by hand or joined on the machine as follows :- With the right side of the back facing you, pick up the stitches from the last row of main yarn onto the back bed needles. With the wrong side of the front facing you (make sure it is the correct shoulder) pick up the stitches from the last row of main yarn onto the same needles. Allow the first stitches to fall behind the latches and pull the second stitches through these. Knit one row at main tension (N/GX, black strippers) and cast off.

#### **Polo Collar**

SIZE (in) 22 24 26 28 30 32 34 36 38 40 42 44

(cm) 56 61 66 71 76 81 86 92 97 102 107 112

STS 82 86 88 92 98 98 106 110 110 110 116 120

Cast on for 1 X 1 rib and knit 60 rows for sizes 22 in. to 28 in., 80 rows for sizes 30 in., 32 in. and 100 rows for sizes 34 in to 44 in. at Tension 5/5.

Transfer the stitches to the back bed. With the right side of the garment facing you, pick up the stitches from around the neck onto the needles already holding the collar. (The stitches from the back neck must be picked up from the stitches of the last row knitted in main yarn). Handle down, Black strippers, N/GX. Main tension plus one whole number. Knit one row. Change to main tension and knit two more rows. Run off on several rows of waste yarn. Press the waste yarn and the last row of main knitting. Join the second shoulder seam in the same way as the first. Unravel the waste yarn on the neck edge until there is only one row left. Pin down the flap. Thread a tapestry needle with a length of the main yarn. Unravel the last row of waste yarn, one stitch at a time and at the same time backstitch through the open loops of the last row of main yarn. This method looks neat, covers imperfections on the neck edge and allows the neck to stretch a little. Fold the collar to the outside.

To make up. Sew in the sleeves. Sew the underarm and body seams.

#### **Alternative crew neck**

Work in the same way as for the polo collar but for 20 rows only. When the neck band sewing has been completed fold the neckband in half to the inside and catch down.

The plain sweater worn with the adult three colour tuck waistcoat has the edges of the ribs knitted in two contrast colours. The first contrast was used to cast on i.e. 1 row N/N. 2 rows CX/CX. 1 row N/N.

The second contrast was used to knit the first two rows of rib before continuing in main yarn.

# STOCKING STITCH SWEATER

Tension 28 stitches, 40 rows = 4 ins. ( 10 cms.) Tension Dial approximately 6½

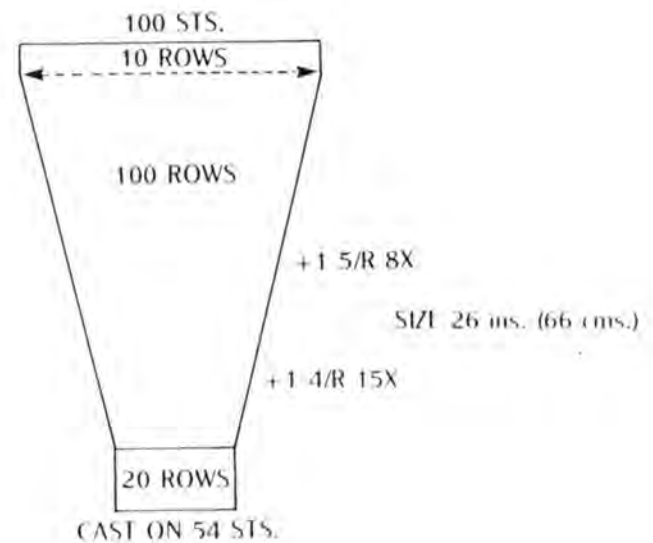
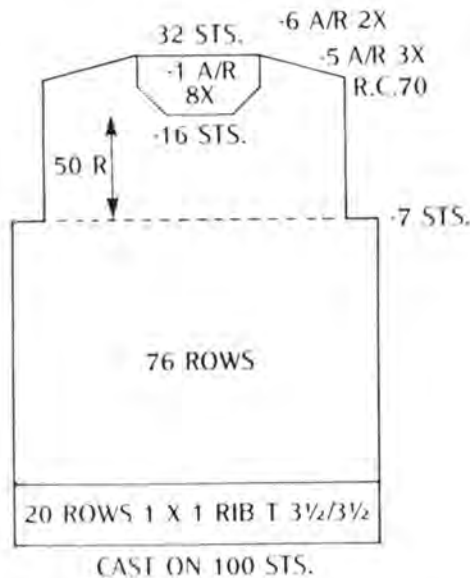
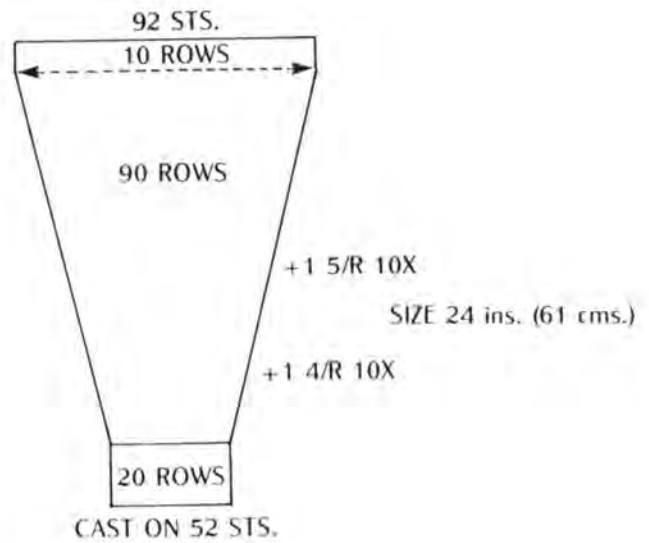
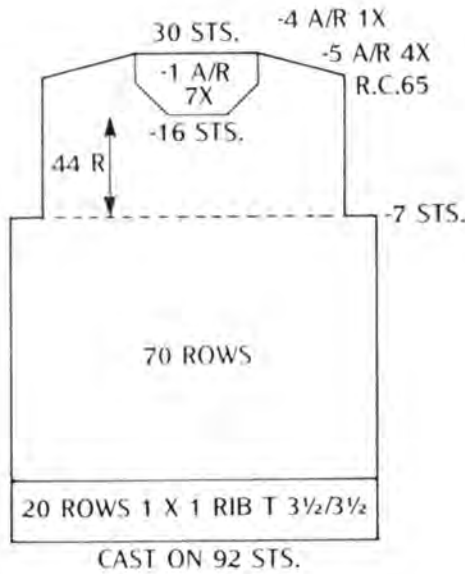
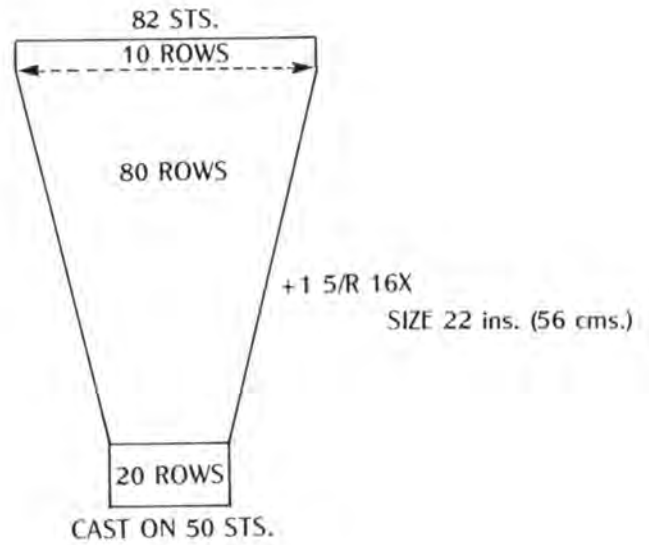
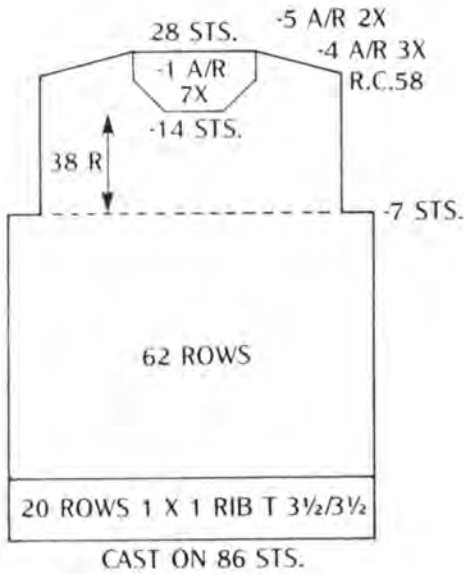

## STOCKING STITCH SWEATER

Tension 28 stitches, 40 rows = 4 ins. ( 10 cms.) Tension Dial approximately 6½

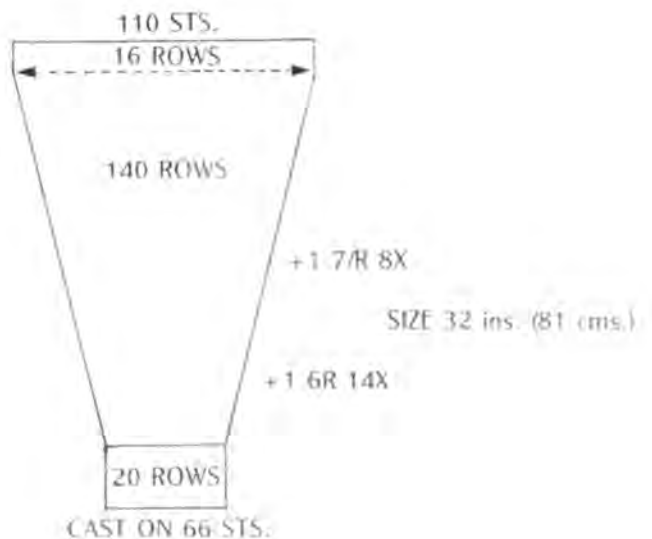
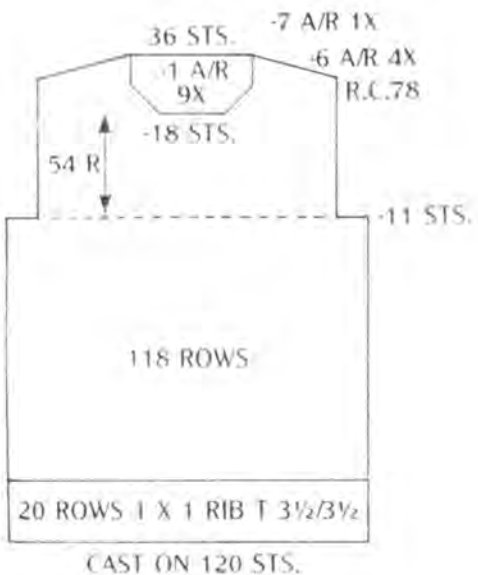
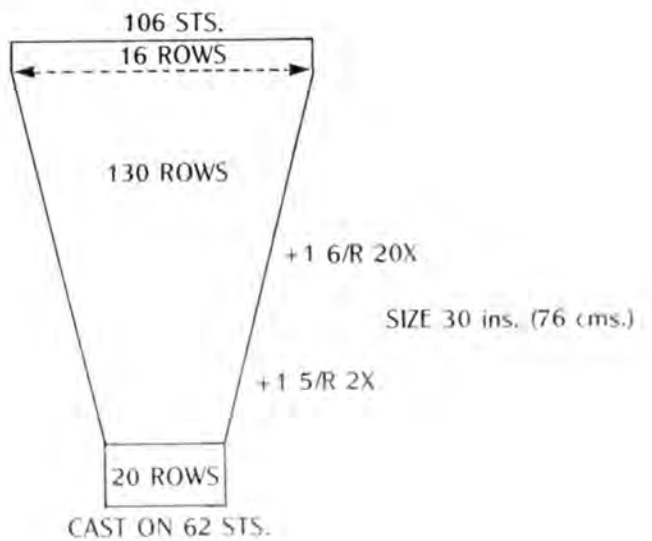
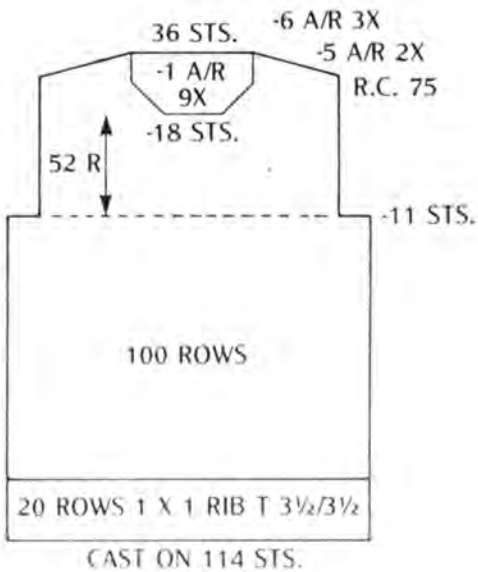
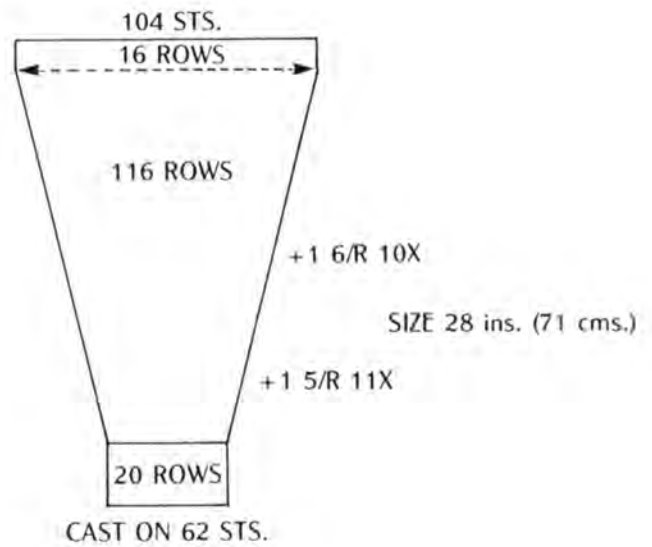
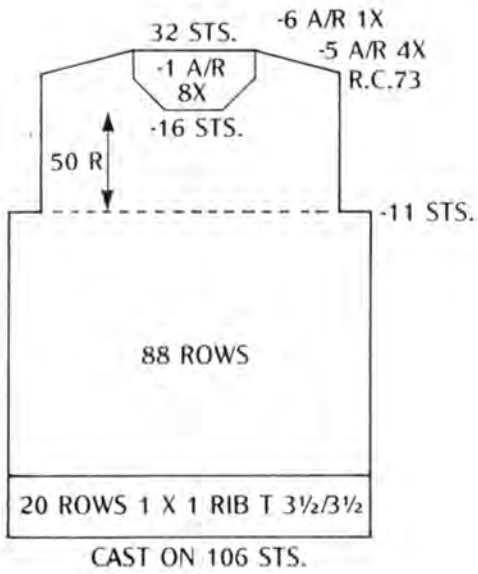



## STOCKING STITCH SWEATER

40 rows, 28 sts = 4 in. (10 cms.) Tension dial 6½

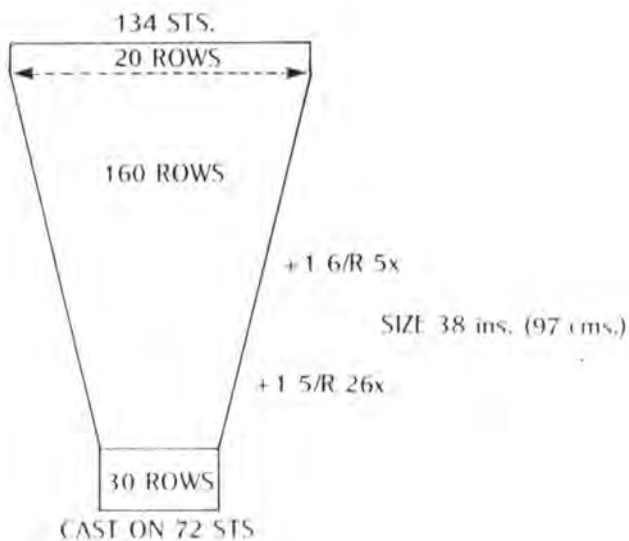
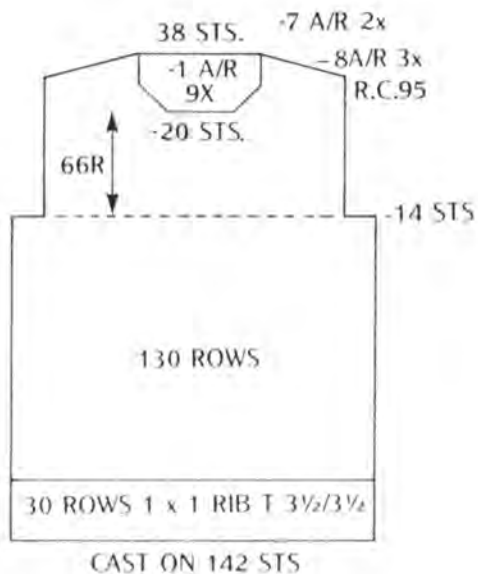
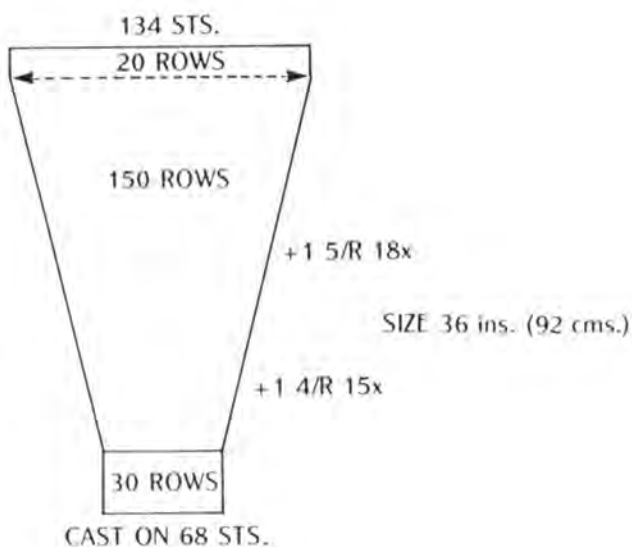
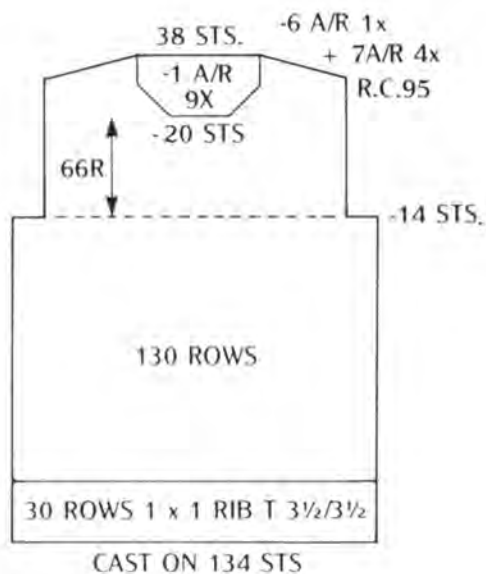
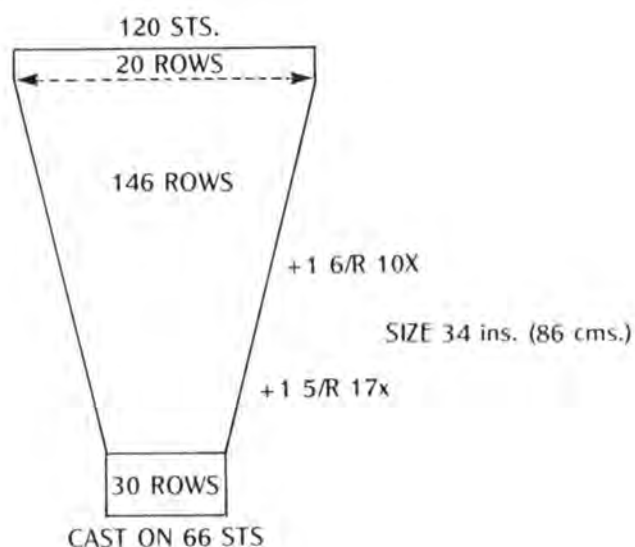
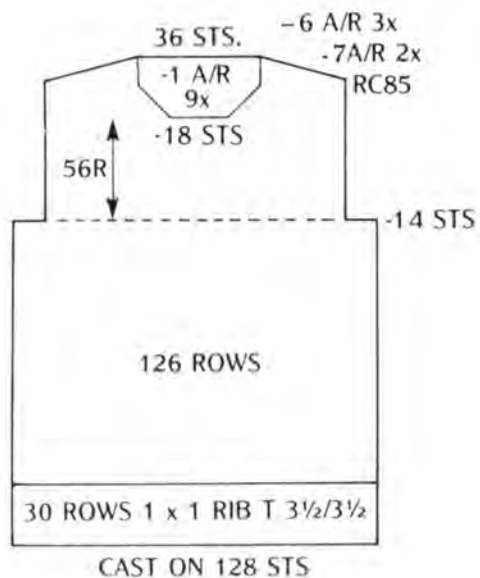

# STOCKING STITCH SWEATER

40 rows, 28 sts = 4 in. (10 cms.) Tension dial 6½

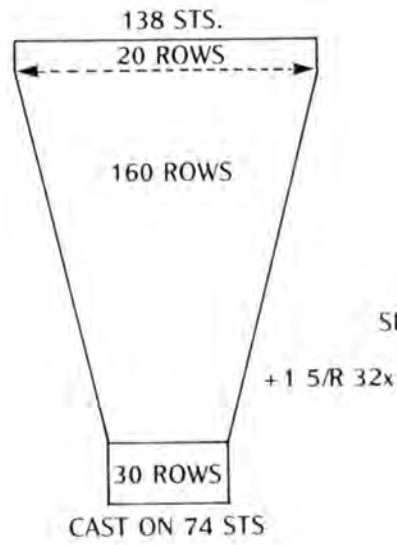
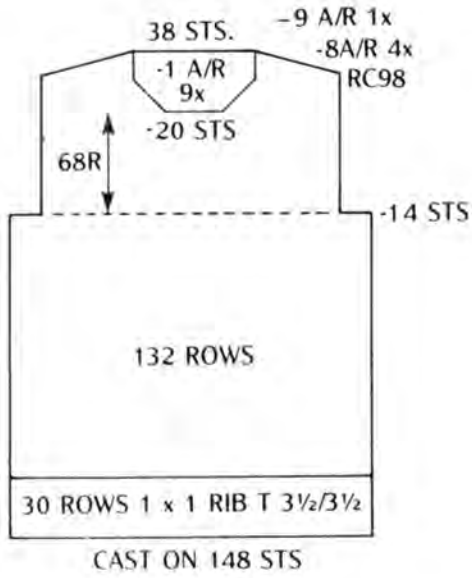

SIZE 40 ins. (102 cms.)

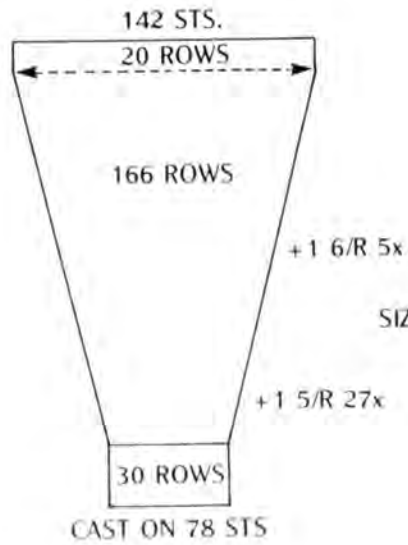
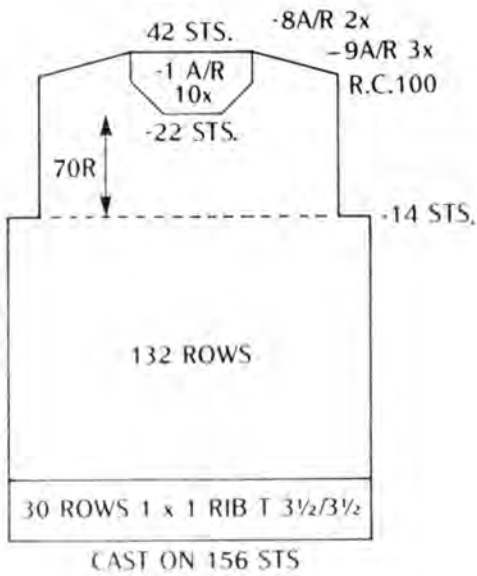

SIZE 42 ins. (107 cms.)

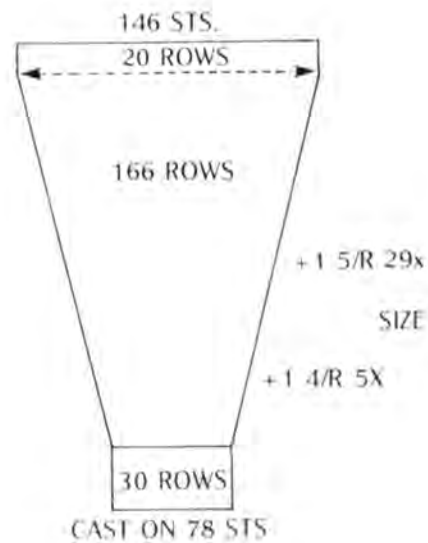
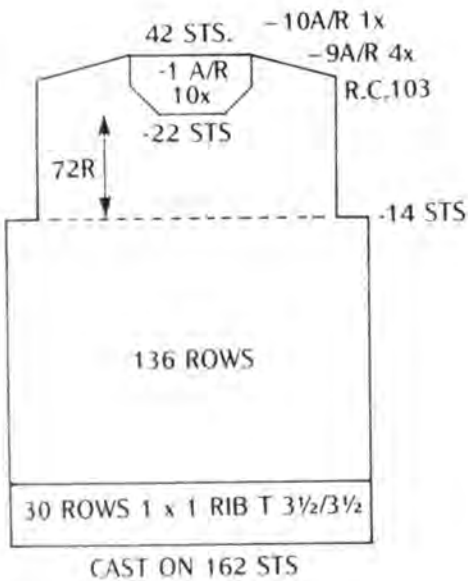

SIZE 44 ins. (112 cms.)

## SWEATER WITH FAIRISLE BANDS

Knitted in Bramwell Fine 4 ply in two colours. Tension 40 rows, 28 stitches = 4 ins. (10 cm.), knitted in stocking stitch. Tension Dial approximately 6½. 100 rows = 10 in. (25.4 cm.) 100 stitches = 14.3 ins. (36.3 cm.) Self punched Deco card. The ribs may be knitted in either the main colour or the contrast colour.

Sizes 22 in., 24 in. and 26 in. have the bottom band repeated at the top. Other sizes have one of the broader fairisle bands at the top.

### Back and front alike

Bring the required number of needles into work and knit the number of rows shown on the diagram, knitting the last row of rib at tension 5/5 to make the first row of fairisle easier for the machine to knit. Transfer the stitches to the front bed. Make sure that all back bed needles are out of work.

### First section of fairisle

Bring up a pusher for each working needle. Set the Deco card on row number 0. Move the row tripper to the left of the knitting. Pass the card reader three times across the card and attach to the lock. Set to 4. R.C. 000. Handle down. Black strippers. GX/BX with the left front arrow key. Tension 6½.

Knit two rows with main colour, two rows with the contrast colour until the row counter shows R.C.20. Ten rows of knitting will actually have been made. Park the card reader on the left hand side.

R.C.000. Handle down. Black strippers. Tension 6½. GX/N.

Knit the first section of stocking stitch. Place a marker thread over each end needle to mark the position of the sleeves. R.C.000 Knit the second section of stocking stitch.

### Second section of fairisle.

For Sizes 22 in., 24in. and 26 in. set the Deco card to row number 0. (as for the fairisle at the beginning.) For other sizes set the Deco to row number 36 at right or row number 12 (after 08). Move the row tripper to the left of the knitting. Pass the card reader three times across the card and attach it to the lock. Set to 4.

R.C.000. Change to GX/BX with the left front arrow key. Knit two rows main colour, two rows contrast until the row counter shows R.C.20 for the first three sizes or R.C.60 for the other sizes.

Park the card reader on the left hand side. Put all the pushers in rest position and cancel the arrow key on the front bed. Work two rows of stocking stitch in main colour.

### Top rib

Transfer the stitches for 1 x 1 rib.

R.C. 000. Handle up. Blue or orange strippers. Tension 4/4. N/N. Knit 20 rows and cast off loosely. Knit another piece the same.

### Sleeves

Use the diagram from the previous stocking stitch sweater pattern for the sleeves but omit the second section of stocking stitch (the straight part) which is only for cut in sleeve styles.

### Making up

Fold half of the top rib inwards and catch down on the wrong side. Put the right sides together. Sew the shoulder seams, leaving an opening for the head to go through ( about 9 ins or 23 cm). Sew in the sleeves between the marker threads. Sew the underarm and body seams.





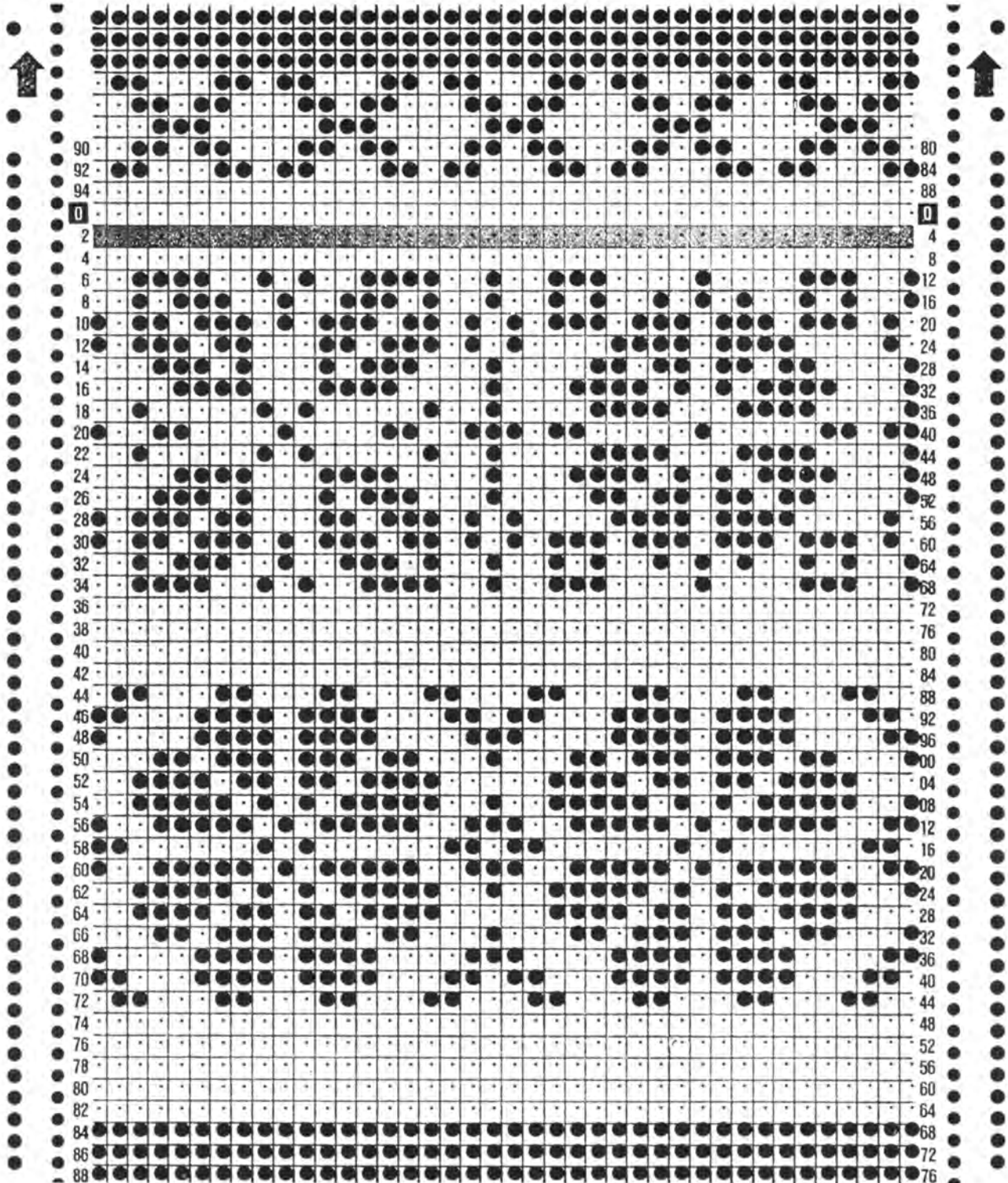

## SWEATER WITH FAIRISLES BANDS

Tension (in Stocking Stitch) 40 rows, 28 sts = 4 in. (10 cms.) Tension dial approx. 6½

SIZE 22 in (56 cm)

20 ROWS 1 X 1 RIB T4/4	
10 ROWS F.I. (RC 20)	
38 ROWS S/S	
-----	
62 ROWS S/S	
10 ROWS F.I. (RC 20)	
20 ROWS 1 x 1 RIB T 3½/3½	

CAST ON 86 STS  
SIZE 28 in (71 cm)

20 ROWS 1 X 1 RIB T4/4	
30 ROWS F.I. (RC 60)	
34 ROWS S/S	
-----	
86 ROWS S/S	
10 ROWS F.I. (RC 20)	
20 ROWS 1 x 1 RIB T 3½/3½	

CAST ON 106 STS  
SIZE 34 in (86 cm)

20 ROWS 1 X 1 RIB T4/4	
30 ROWS F.I. (RC 60)	
46 ROWS S/S	
-----	
124 ROWS S/S	
10 ROWS F.I. (RC 20)	
30 ROWS 1 x 1 RIB T 3½/3½	

CAST ON 128 STS  
SIZE 40 in (102 cm)

20 ROWS 1 X 1 RIB T4/4	
30 ROWS F.I. (RC 60)	
58 ROWS S/S	
-----	
132 ROWS S/S	
10 ROWS F.I. (RC 20)	
30 ROWS 1 x 1 RIB T 3½/3½	

CAST ON 148 STS

SIZE 24 in (61cm)

20 ROWS 1 x 1 RIB T4/4	
10 ROWS F.I. (RC 20)	
46 ROWS S/S	
-----	
70 ROWS S/S	
10 ROWS F.I. (RC 20)	
20 ROWS 1 x 1 RIB T 3½/3½	

CAST ON 92 STS  
SIZE 30 in (76cm)

20 ROWS 1 x 1 RIB T4/4	
30 ROWS F.I. (RC 60)	
36 ROWS S/S	
-----	
100 ROWS S/S	
10 ROWS F.I. (RC 20)	
20 ROWS 1 x 1 RIB T 3½/3½	

CAST ON 114 STS  
SIZE 36 in (92cm)

20 ROWS 1 x 1 RIB T4/4	
30 ROWS F.I. (RC 60)	
56 ROWS S/S	
-----	
130 ROWS S/S	
10 ROWS F.I. (RC 20)	
30 ROWS 1 x 1 RIB T 3½/3½	

CAST ON 134 STS  
SIZE 42 in (107 cm)

20 ROWS 1 x 1 RIB T4/4	
30 ROWS F.I. (RC 60)	
60 ROWS S/S	
-----	
132 ROWS S/S	
10 ROWS F.I. (RC 20)	
30 ROWS 1 x 1 RIB T 3½/3½	

CAST ON 156 STS

SIZE 26 in (66cm)

20 ROWS 1 x 1 RIB T4/4	
10 ROWS F.I. (RC 20)	
50 ROWS S/S	
-----	
76 ROWS S/S	
10 ROWS F.I. (RC 20)	
20 ROWS 1 x 1 RIB T 3½/3½	

CAST ON 100 STS  
SIZE 32 in (81cm)

20 ROWS 1 x 1 RIB T4/4	
30 ROWS F.I. (RC 60)	
38 ROWS S/S	
-----	
118 ROWS S/S	
10 ROWS F.I. (RC 20)	
20 ROWS 1 x 1 RIB T 3½/3½	

CAST ON 120 STS  
SIZE 38 in (97cm)

20 ROWS 1 x 1 RIB T4/4	
30 ROWS F.I. (RC 60)	
56 ROWS S/S	
-----	
130 ROWS S/S	
10 ROWS F.I. (RC 20)	
30 ROWS 1 x 1 RIB T 3½/3½	

CAST ON 142 STS  
SIZE 44 in (112 cm)

20 ROWS 1 x 1 RIB T4/4	
30 ROWS F.I. (RC 60)	
64 ROWS S/S	
-----	
134 ROWS S/S	
10 ROWS F.I. (RC 20)	
30 ROWS 1 x 1 RIB T 3½/3½	

CAST ON 162 STS

## JACQUARD JACKET

Tension 28 stitches, 80 rows = 4 ins (10 cm.) knitted in two colours of Bramwell Duo Spun, using Deco card 30. 100 stitches = 14.3 ins (36.3 cm.) 100 rows = 5 ins (12.7 cm.). Tension Dials approximately 5/5. Tension counted over front bed needles only although back bed needles are in work. The bottom bands are knitted circular (CX/CX)

### Back

Set up the required number of needles on the front bed and the same number on the back bed for an every needle rib cast on using main colour.

Handle down. Blue or orange strippers. N/N Tension 2/2. Knit one row.

CX/CX Tension 3/3 Knit two rows.

N/N Tension 3/3 Knit one row.

R.C. 000. CX/CX Tension 4/4. Knit two rows.

Change to black strippers. Tension 4½/4½ Knit to R.C. 30. R.C. 000. Bring up a pusher for every working needle on both beds. Set the front pushers up and the back pushers in a one up, one down pattern.

Black strippers. BX with both arrow keys on the back bed / BX with the left arrow key on the front bed. Tension 5/5. Move the row tripper to the left side of the knitting. Pass the card reader three times across the card to register the pattern. Attach to the lock. Set to 4.

Knit two rows with main colour, two rows with contrast colour throughout.

It is easy to see whether you have changed yarn as the back bed stitches show the colour of the yarn in which the last row was knitted when the locks are on the colour changer side of the beds.

At the end of the first section of knitting, mark the last stitch at each end of the knitting with a length of contrast yarn, to indicate the sleeve position when making up the garment.

When shaping the shoulders, remember that the number of stitches to be cast off on the front bed is shown but the same number must also be cast off on the back bed. Do not forget to put the empty needles out of work and the pushers back in the blocking rails. Move the row tripper just to the left of the knitting after each decrease. When only the centre number of stitches shown on the diagram are left on the front bed and the same number on the back bed, cast off loosely.

### Fronts

Make sure that the Deco card is returned to 0 for each piece.

The fronts are to be worked in the same way as the back except for the neck shaping. When the neck edge is reached, cast off the number of stitches shown (i.e. 9 stitches for small and medium sizes and 10 stitches for the large size.) on both beds, by transferring the 9 or 10 stitches to one bed and casting the two sets off together. Similarly, one stitch must be decreased on each bed every four rows for the shaping. This can be done by moving a stitch to the next working needle on the same bed.

Reverse the shaping for the second front.





### **Sleeves**

Make sure the Deco card is returned to 0 for each piece.

The sleeves are knitted in the same way as the back and front pieces. When increasing bring up a needle at each end of both beds. Bring out a pusher for each new needle putting the pushers on the back bed into the one up, one down pattern. The Deco will put the front bed pushers into their correct positions. Knit the required number of rows and cast off very loosely.

### **Button Band**

Handle down, blue or orange strippers. Using 9 needles on each bed for every needle rib, cast on in main yarn, using tension 3/3, knit 204 rows for small or medium sizes or 211 rows for large size.

### **Buttonhole Band**

Small or medium size garment :- Buttonholes should be made when the row counter shows 8, 35, 62, 89, 116, 143, 170, and 197.

Large size :- Buttonholes should be made when the row counter shows 8, 36, 64, 92, 120, 148, 176, 204.

To make the buttonhole, transfer the middle stitch from the front bed onto the fourth needle from the right on the back bed. Transfer the middle stitch from the back bed onto the fourth needle from the left on the front bed.

### **Collar**

Handle down, Blue or orange strippers. Set up 130 needles on each bed for every needle rib. N/N, tension 3/3, knit 1 row. CX/CX tension 3/3. Knit 2 rows. N/N tension 3/3, knit 46 rows. Cast off loosely.

### **Making Up**

Sew on the front bands, Join the shoulder seams and sew in the sleeves. Join the side and underarm seams. Sew on the collar, covering only half of the front band on each side with the collar. Sew on the eight buttons.

### **Pressing**

This garment may be steamed by hovering over it with the steam iron whilst gently patting the fabric with the flat of the hand.

# JACQUARD JACKET

80 rows, 28 sts = 4 in. (10 cms.) Tension dial 5/5

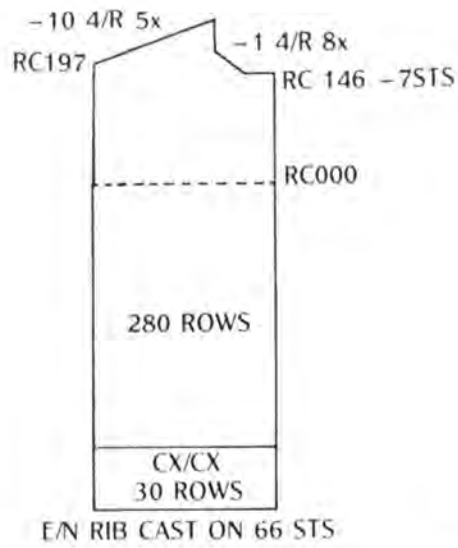
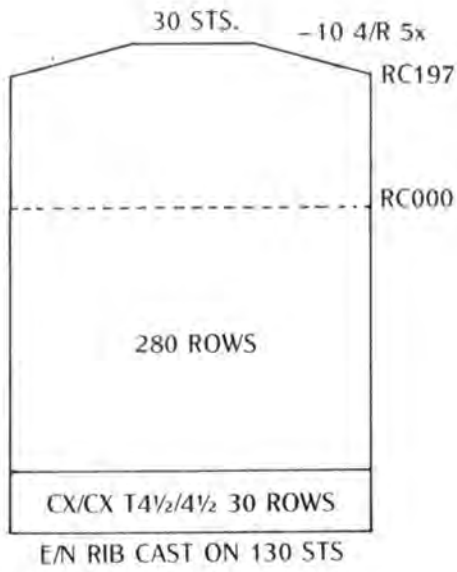

SMALL SIZE  
32 in + 34 in  
(81cm + 86 cm)

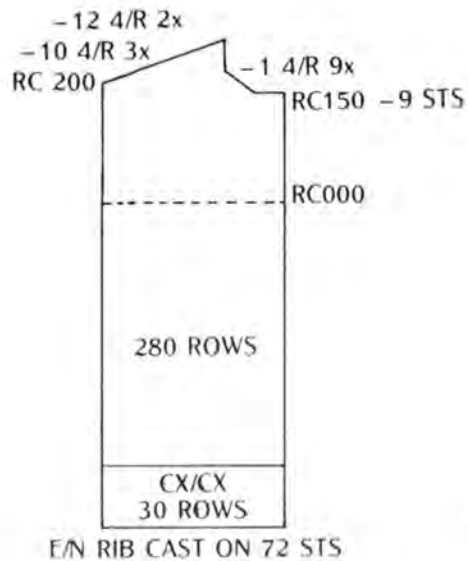
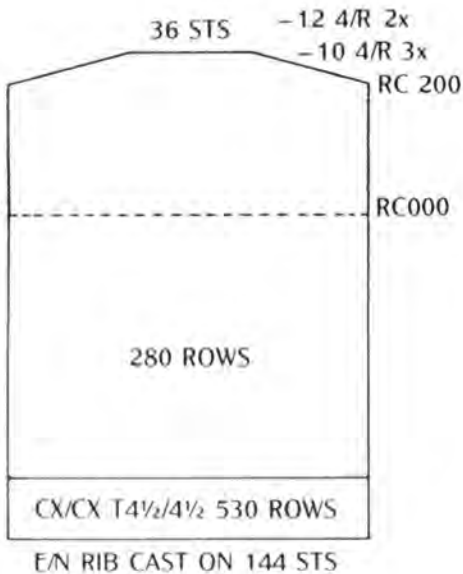
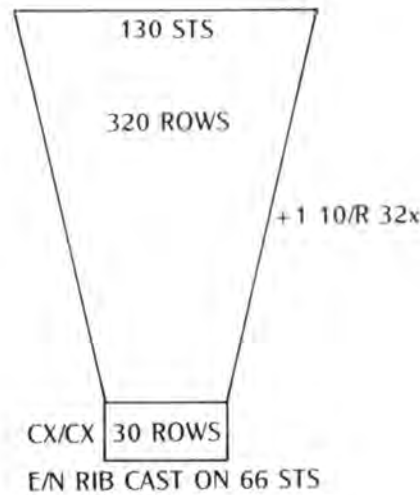

MEDIUM SIZES  
36 in + 38 in  
(92 cm + 97 cm)

# JACQUARD JACKET

80 rows, 28 sts = 4 in. (10 cms.) Tension dial 5/5

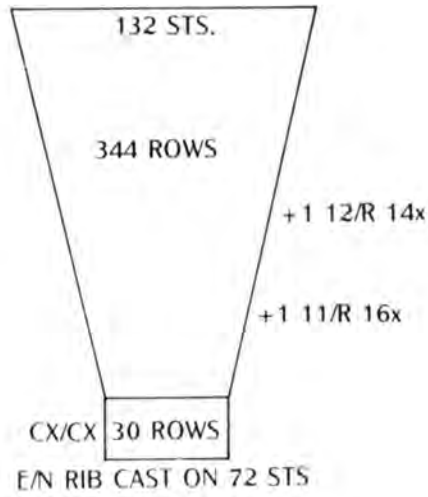

MEDIUM

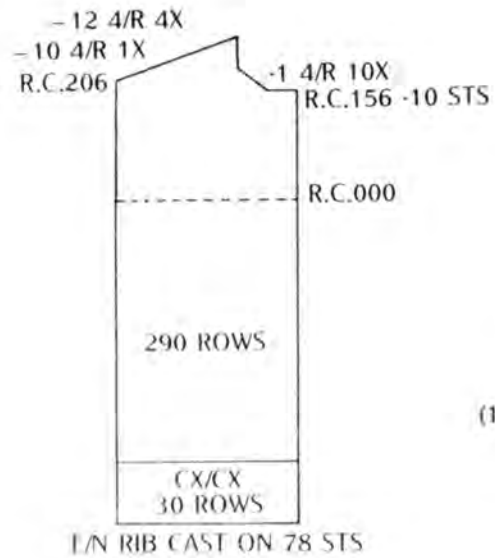
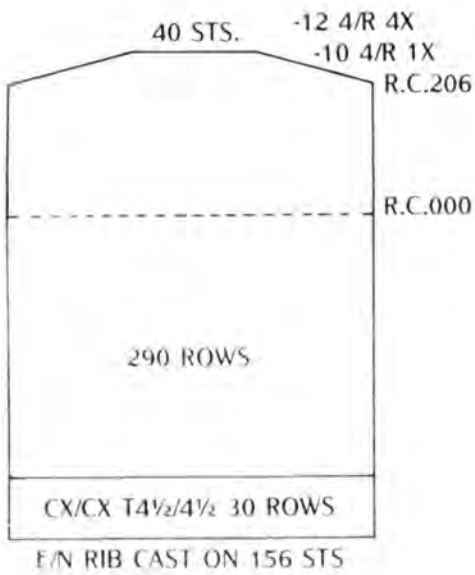

LARGE SIZES  
40 & 42 INS  
(102 & 107 CMS.)

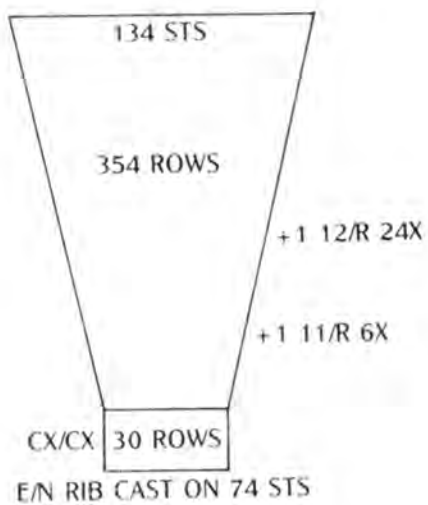

## ONE SIZE SWEATER IN ASTRAKAN

Use one strand of Astrakan. One cone of yarn required. The tension of the fabric will vary considerably as it is soft and very flexible but as a rough guide 60 rows, 14.5 stitches = 4 in. (10 cm.). 100 rows = 6.7 in. (17 cm.), 100 sts. = 27.7 in (70.4 cm.). Tension dial approx. 4/4 The sweater will fit sizes 34in (86 cm.) to 38 in. ((102 cm.) but by increasing the tension by one quarter on the tension dial a size 40 in. (107 cm.) will be obtained. Stripes may be inserted which will, according to their position, run around the arms or over the shoulders to the back and front. If the stripes are inserted on the body shaping they will meet in a Vee shape on the body seam. If a smooth fine yarn is used for the stripes, e.g. 2 strands of 2/30 or 2 strands of Silky then the tension dial number must be increased for the duration of the stripes by at least a quarter of a tension.

The diagram is self explanatory but a little guidance is given for those knitters who may need it.

The number of needles shown on the pattern is for the front bed only but the same number will also be used on the back bed.

### Increasing

Increase by putting an extra needle in work on each end of both beds. Bring up a pusher on the front bed for each new needle, putting it in the one up, one down pattern. Use a small weight on each edge of the fabric.

### Decreasing

Decrease by using a single prong tool to decrease one stitch at each end of both beds. Put the needle out of work and, on the front bed, the pusher back into the blocking rail. Use a small weight on each edge of the fabric.

### Neckline

The pattern given is for a roll collar but the neckband for the cut and sew neckline, given at the front of the book, may be used. As an alternative, the cowl collar pattern given below may be used.

The measurements given for sewing and cutting the hole are for backstitching twice round the neckline, if a sewing machine is used then a larger hole must be made as the handstitching method allows the fabric to stretch. The 3 in. (7.5 cm.) depth should be slightly more to the front than the back.

### Roll Collar

Sew the side edges of the collar together to form a circle. Sew the cast off edge to the right side of the neckline, putting the right side of the collar to the right side of the garment. Fold the collar in half with the right side showing and catch down the cast on edge to the inside of the neckline, enclosing the cut edge.

### Cowl Collar

Cast on 90 stitches on each bed for every needle rib using tension 3/3 for the N/N row and tension 4/4 for the two CX/CX rows. Bring up a pusher for each working needle on the front bed and arrange in a one up, one down pattern. Handle down, blue or orange strippers. N/AX both arrow keys on the front bed.

Tension 4/4 Knit 40 rows.

Tension 4¼/4¼. Knit 40 rows.

Tension 4½/4½. Knit 80 rows.

Tension 4¼/4¼ Knit 40 rows.

Tension 4/4. Knit 40 rows. Cast off loosely.

Attach the cowl collar in the same manner as the roll collar above.

### Bottom ribs

Knit the rib and transfer the stitches to the back bed. Pick up bottom edge of the front of the garment onto the needles already holding the rib stitches with the wrong side of the garment facing you. Change to black strippers. N/GX. Tension 5. Knit one row and cast off. Use the same method for the sleeve ribs.

Sew the underarm and body seams.





# SWEATER KNITTED FROM CUFF TO CUFF IN ASTRAKAN

Tension dials approximately 4/4

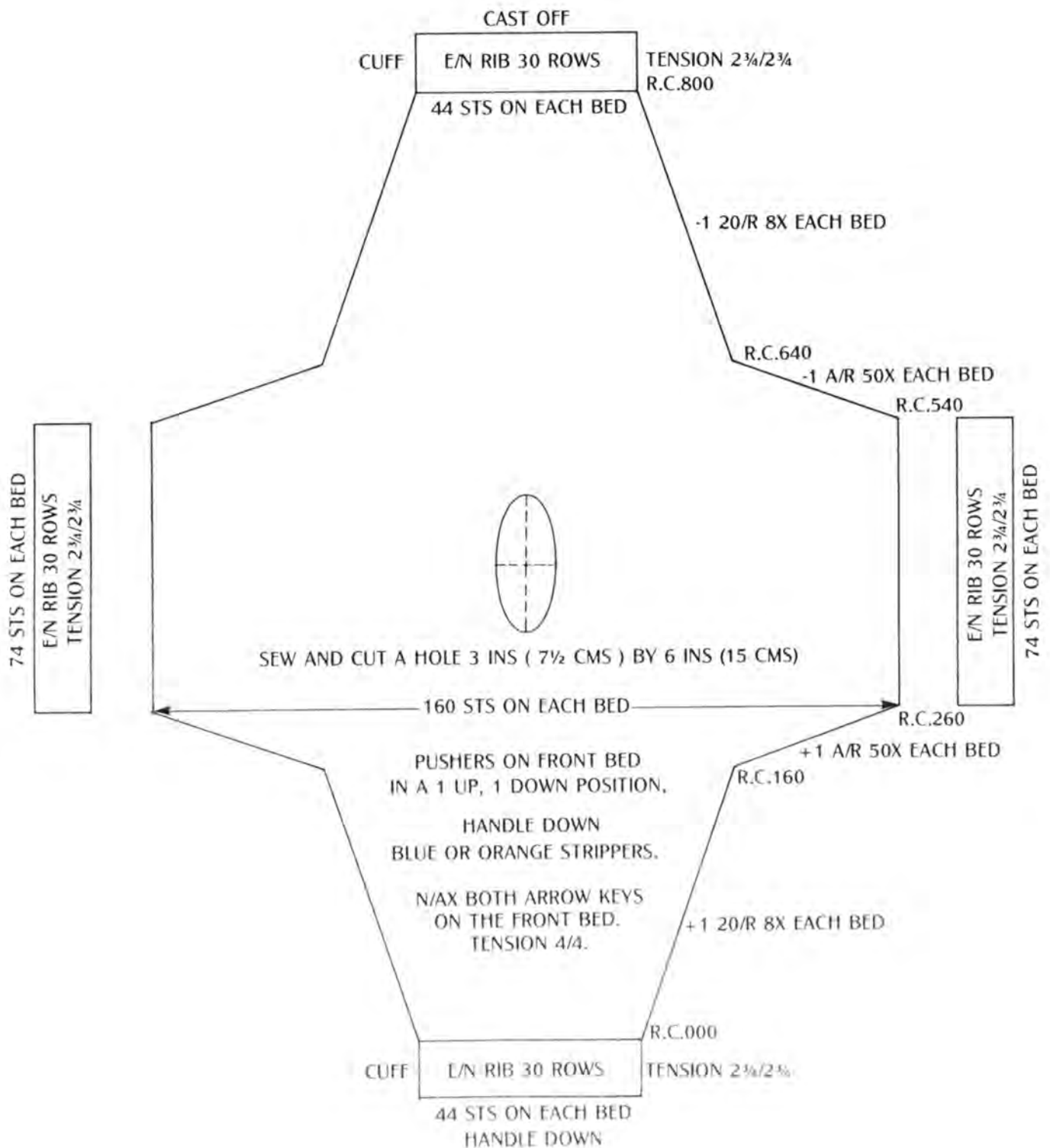

ROLL COLLAR Handle down blue or orange strippers. Cast on loosely 80 sts on each bed for every needle rib. Bring a pusher up for every working needle on the front bed and arrange in a 1 up 1 down pattern. N/AX Both arrow keys on the front bed.

- T4/4 Knit 30 rows
- T4 1/4 / 4 1/4 Knit 30 rows
- T4 1/2 / 4 1/2 Knit 30 rows
- T4 1/4 / 4 1/4 Knit 30 rows
- T4/4 Knit 30 rows Cast off loosely.

## STRAIGHT SKIRT IN ARTISTIC

Straight skirts are popular at the present time, this one, because of its ribbed top, is comfortable to wear and easy to make. One cone of yarn will be required for small sizes but a second cone will be required for larger sizes or long lengths. Tension 26.5 stitches, 55 rows = 4 ins ( 10 cm.) 100 stitches = 15 ins ( 38 cm.) 100 rows = 7.25 ins. ( 18.4 cm.) Knitted in one strand Bramwell Artistic N /CX Tension dials approximately 5/6.

A comb and weights may be used when knitting this garment as this method gives more even knitting and less steaming is required.

It is normal to allow ease on a garment but in this case please decide for yourself the amount of ease required and knit the appropriate size. Young ladies may like the garment to be tight and clinging, in this case no ease is required. If you do not want this effect then measure the widest part of the hips and add at least two inches ( 5cm.) for ease. Actual hip measurement of the garment is given below.

Measurement (ins)	30	32	34	36	38	40	42	44
(cm.)	76	81	86	92	97	102	107	112
No. of needles	100	106	112	120	126	132	140	146

Handle down. Set up the number of needles shown for every needle rib on both the back and the front bed.

Blue or orange strippers. N/N Tension 2½/2½ Knit one row.

CX/CX Tension 3½/3½ Knit two rows.

N/N Tension 3½/3½ Knit one row.

N/CX Tension 5/6. Knit the number of rows for the length of skirt you require. The knitting will look far too short but there is still the rib of approximately 3.5 ins ( 9 cm.) to be knitted plus the waistband. The waistband is not included in the measurements given.

Length in ins.	18	19	20	21	22	23	24	25
cm.	46	48	51	53	56	58	61	64
No of rows	200	214	226	240	254	268	282	296

Length in ins.	26	27	28	29	30	31	32
cm.	66	69	71	74	76	79	81
No. of rows	310	324	336	350	364	378	392

Handle up. Transfer the stitches to 1 x 1 rib. Put all the empty needles out of work.

R.C. 000 Blue or orange strippers. N/N Tension 3½/3½. Knit 49 rows. Tension 5/5 knit one row.

R.C. 000.

Black strippers. N/GX. Tension 5 on the back bed. Knit 1 row.

N/GX. Tension 6 on the back bed. Knit 22 rows

Blue or orange strippers N/N Tension 5/5. Knit one row.

Cast off loosely.

Knit another identical piece.

Steam each piece by hovering over it with the steam iron. Avoid steaming the 1 x 1 rib and the waistband. Leave to dry.

Join the side seams. Steam them, but again avoid the 1 x 1 rib and the waistband. Leave to dry. Thread 1 inch (2.5 cm.) elastic through the waistband.

The skirt should be dried flat when it is washed.

## TOP WITH DIAGONAL STRIPES IN ARTISTIC

Knitted in one strand of Artistic in stocking stitch. Tension Dial approximately 5½. Tension 31 stitches, 49 rows = 4 in (10 cm.) measured after the fabric has been blocked and pressed using a steam iron on a cool setting. 100 rows = 12.9 inches (32.8 cm.), 100 stitches = 8.2 ins (20.8 cm.). (Pin the piece of knitting to size, steam press and leave to dry before measuring.). One cone of the main yarn will be required, plus small amounts of two contrast colours.

### Back

Handle down. Black strippers. GX/N Tension 5½. Cast on two stitches in waste yarn on the front bed, using the single bed cast on and knit a few rows to make sure the stitches are knitting properly. Change to main yarn.

### Increasing

R.C. 000. \* Knit one row. Bring an extra needle into work on the same side as the lock. \* This is repeated until the centre row number is shown on the row counter, but remember to insert the stripes when you have knitted to the row number shown on the diagram for the beginning of the stripes. Hang a weight on the right hand side of the knitting to prevent the edge tightening up and move it up the knitting frequently.

### Stripe pattern for all sizes.

2 rows contrast B 2 rows contrast C

6 rows main colour

There are 104 rows of stripes on all sizes.

When the row counter shows the correct number for the centre row, increase one stitch on the same side as the locks and decrease one stitch on the opposite side to the locks. Continue in stripe sequence and begin the decreasing. Hang a small weight on each edge of the knitting.

### Decreasing

\* Knit one row and decrease one stitch on the opposite side to the locks.\* This is repeated until only two stitches are left in work. Cast off. Fasten off the two stitches at the beginning of the piece and remove the waste yarn.

### Front

Work as for the back but use the following stripe pattern.

2 rows contrast C 2 rows contrast B 6 rows main colour.

### Sleeves

Black strippers. Cast on the required number of stitches on the front bed and knit several rows in waste yarn.

R.C.000 Change to main yarn and knit the required number of rows. Cast off loosely.

### Blocking and pressing

Block and press the pieces to the measurements given on the diagrams. Use a steam iron on a cool setting. Leave the pieces to dry before removing them from the surface on which they have been blocked. Arrange the back and front pieces on a table and decide which is the top and bottom of each piece. The stripes should match up on a side seam. Mark the bottom edges with a length of contrast yarn and mark the top edges with a different colour. Make a note of your code so that you do not become confused.



### **Back and Front ribs**

It is not possible to use as many stitches for the 1 x 1 rib as is usual because the edge of the knitting will not stretch. Make sure before you begin the ribs that the edge of the fabric which you are going to pick up will stretch over the number of needles given, if not, use fewer needles for the ribs.

Size in in.      30 32 34 36 38 40

Size in cm.     76 81 86 92 97 102

No. of needles. 90 94 100 106 110 116

Knit 40 rows at Tension 4/4 for the bottom rib on each piece. Knit the last row at tension 5/5.

Knit 10 rows at tension 5/5 for the top rib on each piece.

When the rib has been knitted transfer the stitches to the back bed. Lower the front bed. With the wrong side of the fabric facing you, pick up the correct edge onto the same needles. Close the beds. Handle down. Black strippers. N/GX. Tension 6½. Knit one row. Cast off loosely.

### **Sleeves**

Knit the cuff in 1 x 1 rib according to the diagram. Knit the last row at tension 5/5. Transfer the stitches to the back bed. Lower the front bed. With the wrong side of the sleeve facing you, pick up the stitches evenly from the first row knitted in main yarn onto the needles already holding stitches. It will be necessary to put two or three of the sleeve stitches onto each needle. Close the beds. Handle down. Black strippers. N/GX. Tension 6½. Pull the fabric down under the machine and knit one row. Cast off loosely. Remove the waste yarn. Repeat for the other sleeve.

### **Making up**

Join the shoulders leaving a gap large enough for the head to go through. Sew in the sleeves. Join the side and underarm seams. Steam the seams and pat into shape. Do not press with the iron or the fabric could be distorted.



## TOP WITH DIAGONAL STRIPES IN ARTISTIC

Tension 31 sts, 49 rows = 4 ins. (10 cms.) after pressing. Tension dial approximately 5½

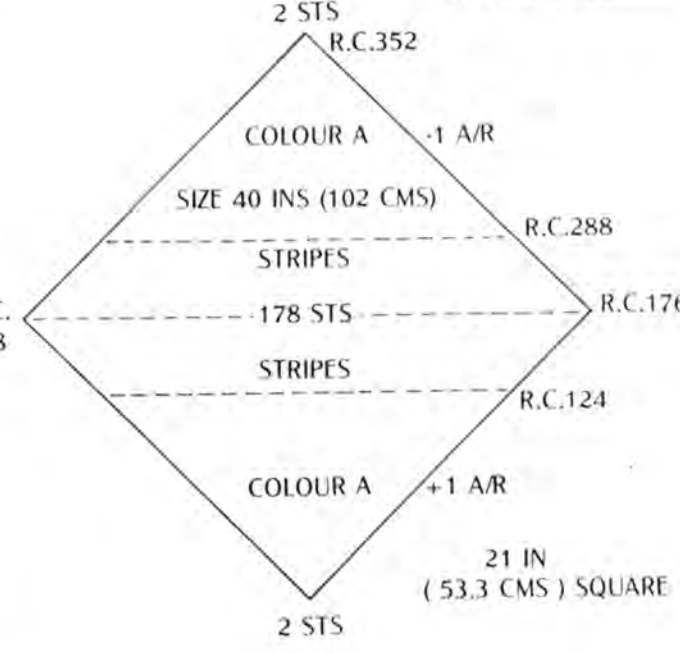
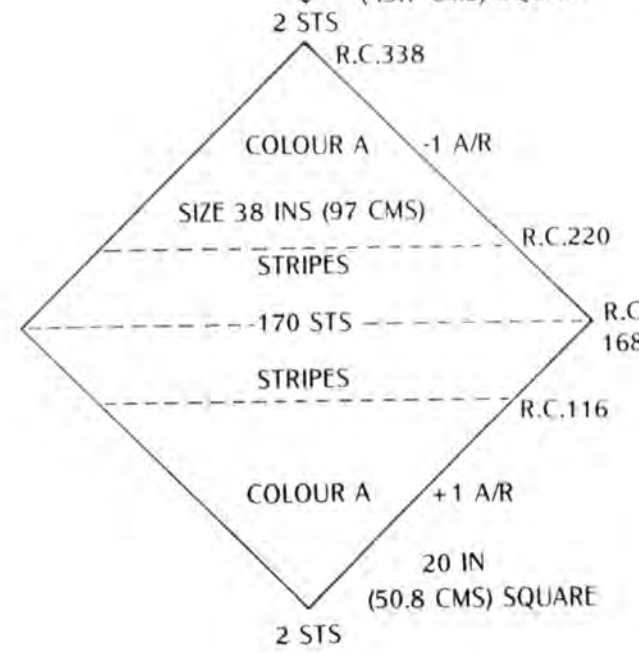
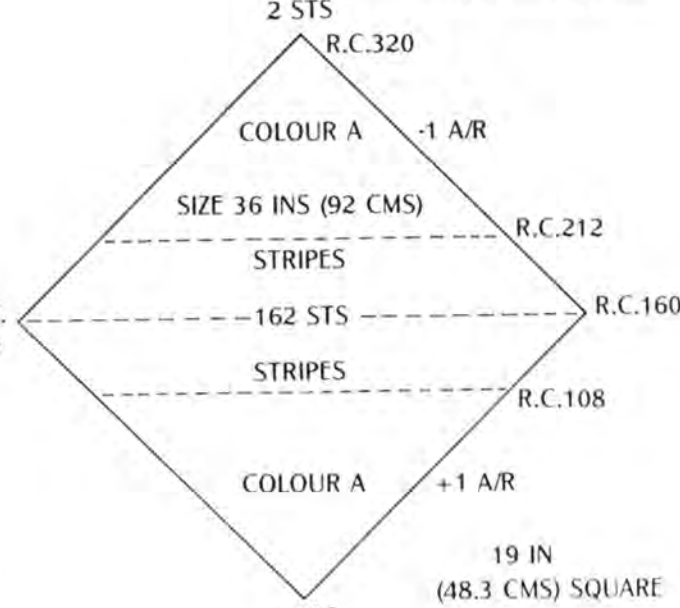
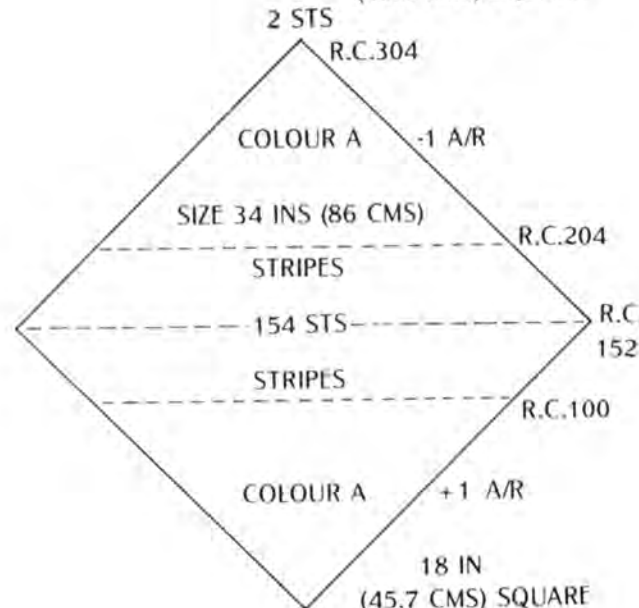
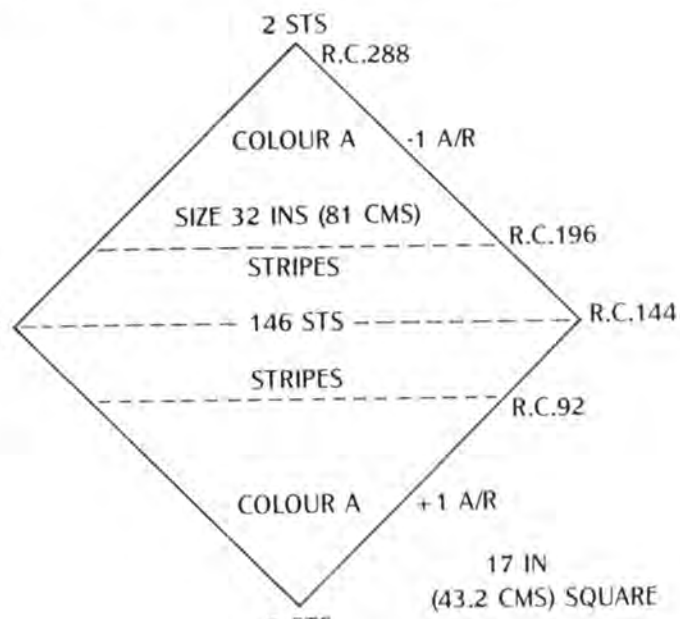
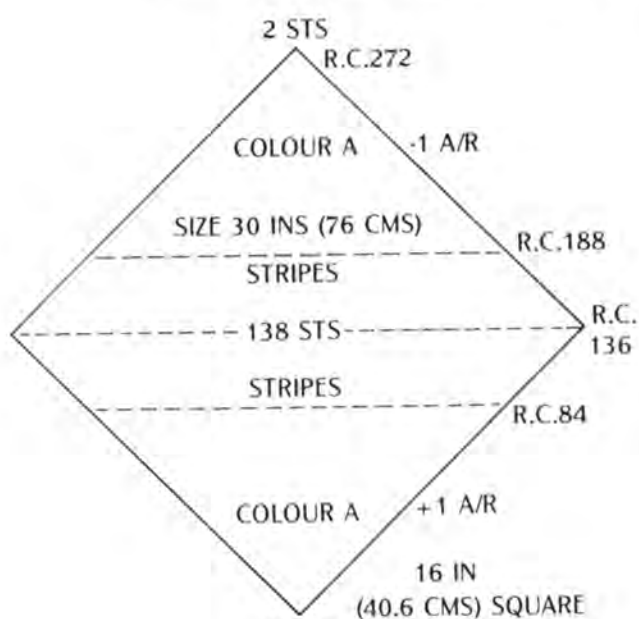

## PLAIN SLEEVES FOR TOP WITH DIAGONAL STRIPES IN ARTISTIC

Tension 31 sts, 49 rows = 4 ins (10 cms.) after pressing. Tension Dial approximately 5½

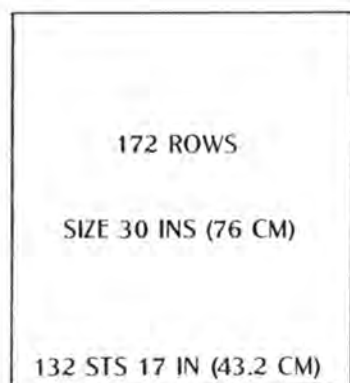

58 STS 1 X 1 RIB  
T3½/3½

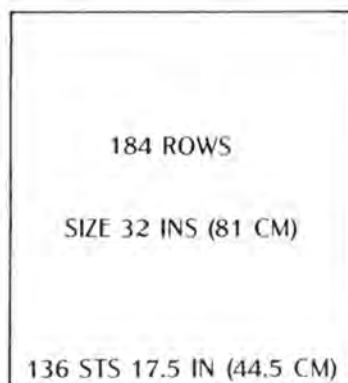

62 STS 1 X 1 RIB  
T3½/3½

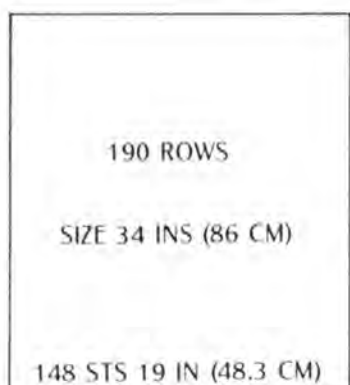

66 STS 1 X 1 RIB  
T3½/3½

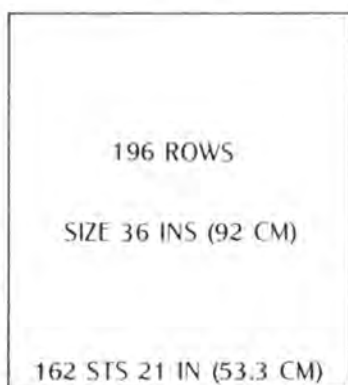

70 STS 1 X 1 RIB  
T3½/3½

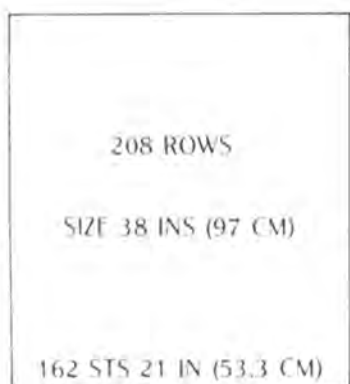

70 STS 1 X 1 RIB  
T3½/3½

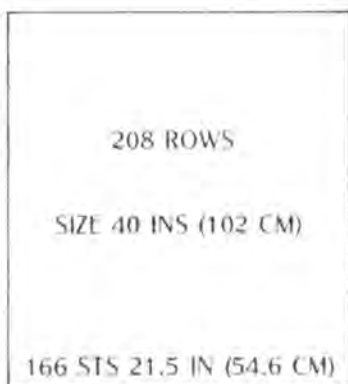

72 STS 1 X 1 RIB  
T3½/3½

PRESS THE SLEEVES OUT TO THE MEASUREMENTS GIVEN BEFORE ADDING THE CUFFS.

## INTARSIA TOP IN ARTISTIC

Knitted in one strand of Artistic in stocking stitch. Tension Dial approximately 5½. Tension 31 stitches, 49 rows = 4inch (10 cm.) measured after the fabric has been blocked and pressed using a steam iron on a cool setting. 100 rows = 12.9 inches (32.8 cm.), 100 stitches = 8.2 ins (20.8 cm.). (Pin the piece of knitting to size, steam press and leave to dry before measuring.). One cone of main colour will be required and a small amount of a contrast colour.

### Back

With main colour and blue or orange strippers cast on using Tension 2½/2½ for the N/N row and Tension 3¼/3¼ for the two CX/CX rows. Knit the rib at Tension 3½/3½. Knit the last row at Tension 5/5. Transfer the stitches to the front bed.

R.C.000. Handle down. Black strippers. GX/N. Tension 5½. Knit the first section up to the armhole cast off. Do not turn the row counter back to 000. Cast off 14 stitches at the beginning of the next two rows. Knit the second section.

Handle up. Transfer the stitches for 1 x 1 rib. Put the empty needles out of work.

R.C.000. Blue or orange strippers. N/N. Tension 5/5. Change to contrast yarn and knit 10 rows. Cast off loosely.

### Front

Please note :- The armhole cast off for the first and second sizes is made before the intarsia section but on the four larger sizes it is made during the intarsia patterning and it will be necessary to keep an eye on the Row Counter so that the armhole cast off is not omitted by accident. Remember to put the pushers back into the blocking rail after the cast off.

Knit as for the back until the row counter number shown on the diagram for the intarsia section. Bring a pusher out of the blocking rail for every working needle

### Intarsia

Place a heel grip or claw weight under the section where the pushers are being changed and move it along frequently.

#### Section 1

Knitted in the main colour. Push down to rest position all the pushers on the left hand side and needle number 1 pusher on the right hand side. The right hand pushers should be in working position except for number 1. Have the Row Counter tripper on the right hand side of the knitting. GX/BX (no arrow key).

\* Knit to left. Put the next pusher down to rest position. Knit to right.\*

Repeat \* to \* until only two pushers at the right hand side are in working position. Put the two pushers down to rest position. Break the yarn and move the locks to the left.

#### Section 2

Put the Row Counter tripper to the left hand side of the knitting. Turn the Row Counter back to the number shown for the beginning of the intarsia. Hang the heel grip or claw weight to the part of the knitting where the pushers are to be moved. Thread the eyelet with the main colour. Bring all the pushers on the left hand side, except for needle number 1 pusher, up into working position.

\*\* Knit to right. Put the next pusher down into rest position. Knit to left.\*\*

Repeat \*\* to \*\* until only two pushers at the left hand side are in working position. Put those pushers down. Break off the main yarn.



### Section 3

Put the row counter tripper to the centre of the knitting. Turn the row counter back to the number shown for the beginning of the intarsia. Hang a weight on the centre of the knitting and leave it there. Bring up into working position the two centre pushers. Thread the eyelet with the contrast yarn.

\*\*\* Knit one row. Bring up a pusher into working position on the side nearest to the locks. \*\*\*

Repeat \*\*\* to \*\*\* until there are three pushers still in rest position on the same side as the locks and two on the side opposite to the locks. Bring up a pusher, as usual, on the same side as the locks and also the two on the opposite side. Knit one row.

#### Top rib

Transfer the stitches for the 1 x 1 rib. Put the empty needles and the pushers out of work. Blue or orange strippers. N/N. Tension 5/5. Knit 10 rows of rib in the contrast colour. Cast off loosely.

#### Sleeves

Black strippers. Using waste yarn, cast on, on the front bed, the required number of stitches and knit several rows in waste yarn until all the stitches are knitting properly.

R.C. 000 Tension 5½. Change to main yarn and knit the first section. Place a marker thread on each end needle. Knit 24 rows and cast off loosely.

#### Blocking and pressing

DO NOT PRESS THE RIBS.

Back and front sections

Block the stocking stitch sections out to the following measurements:-

	INCHES						CENTIMETRES						
Size	34	36	38	40	42	44	Size	86	92	97	102	107	112
Width bottom	18	19	20	21	22	23	Width bottom	45.0	48.2	50.8	53.3	55.9	58.4
Width top	14	15	16	17	18	19	Width top	35.7	38.2	40.2	43.3	45.9	48.4
Length	21	22½	22½	23	23¼	23¼	Length	53.3	57.1	57.1	58.4	59.0	60.3

Sleeves. The measurement for the width and full length of each sleeve is given on the diagram.

Allow each piece to dry before moving it from the surface on which it has been pressed.

#### Cuffs

Knit the cuff in 1 x 1 rib according to the diagram. Knit the last row at Tension 5/5. Transfer the stitches to the back bed. Lower the front bed. With the wrong side of the sleeve facing you, pick up the stitches evenly from the first row knitted in main yarn onto the needles already holding stitches. It will be necessary to put two or three of the sleeve stitches onto each needle. Close the beds. Handle down. Black strippers. N/GX. Tension 6½. Pull the fabric down under the machine and knit one row. Cast off loosely. Remove the waste yarn. Repeat for the other sleeve.

#### Making up

Join the shoulders leaving a gap large enough for the head to go through. Sew in the sleeves. Join the side and underarm seams. Steam the seams and pat into shape. Do not press with the iron or the fabric could be distorted.

Ribbon or cord may be threaded through the small holes around the shape of the intarsia and tied in a bow at the bottom of the Vee.



## INTARSIA TOP IN ARTISTIC

Tension 31 sts, 49 rows = 4 ins (10 cms.) after pressing. Tension Dial approximately 5½

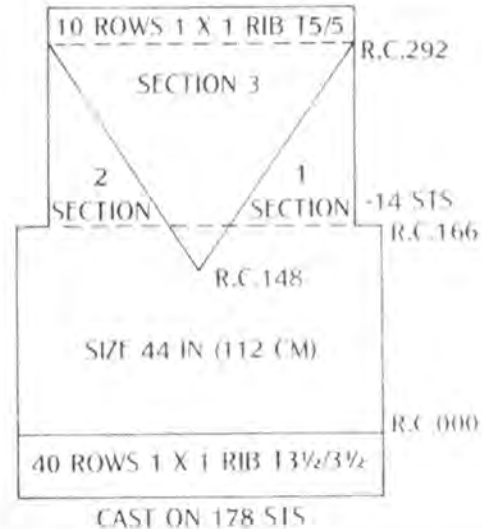
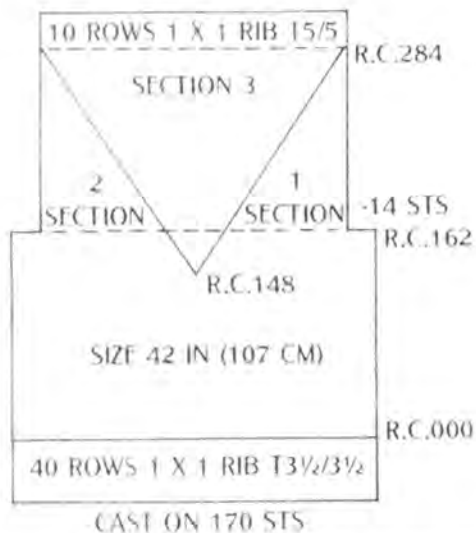
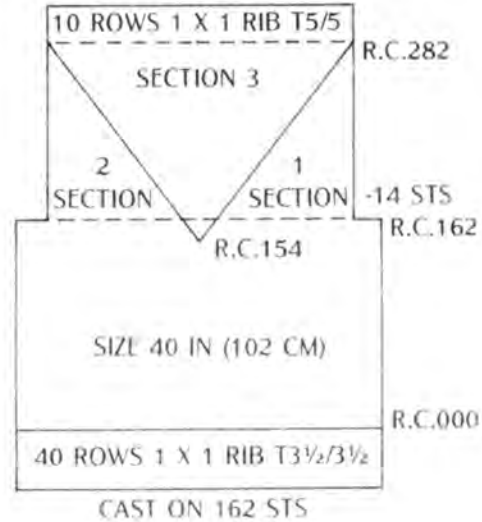
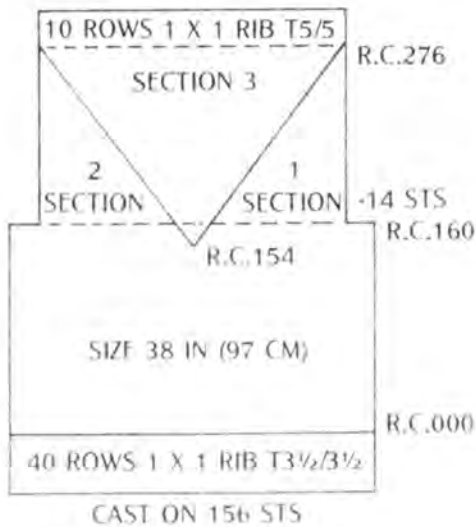
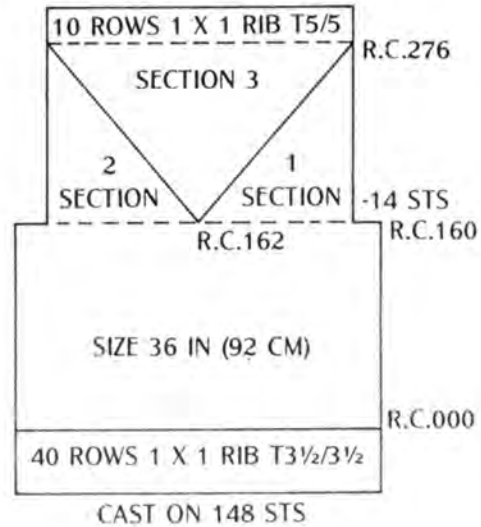
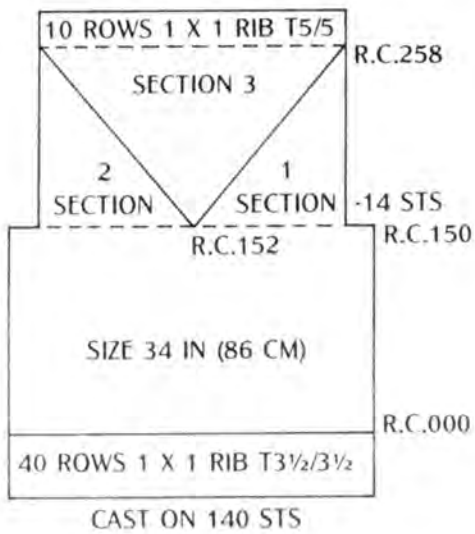

PRESS THE STOCKING STITCH PARTS TO THE MEASUREMENTS GIVEN IN THE INSTRUCTIONS BEFORE MAKING UP THE GARMENT.

## SLEEVES FOR INTARSIA TOP IN ARTISTIC

Tension 31 sts, 49 rows = 4 ins (10 cms.) after pressing. Tension Dial approximately 5½

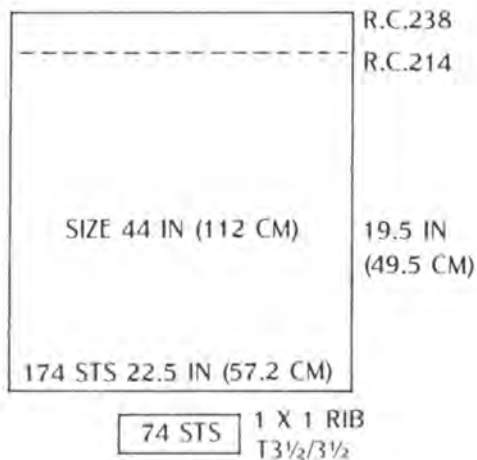
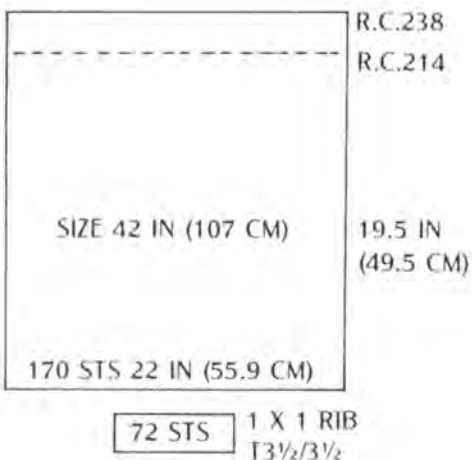
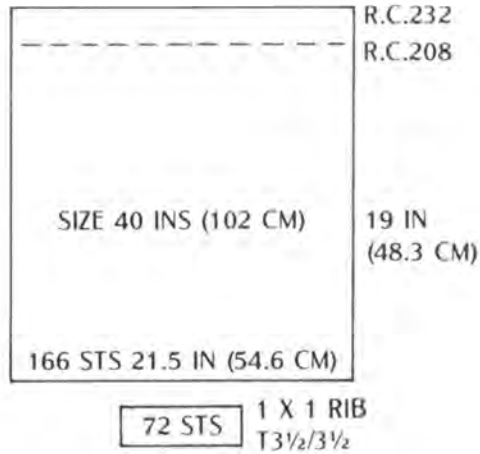
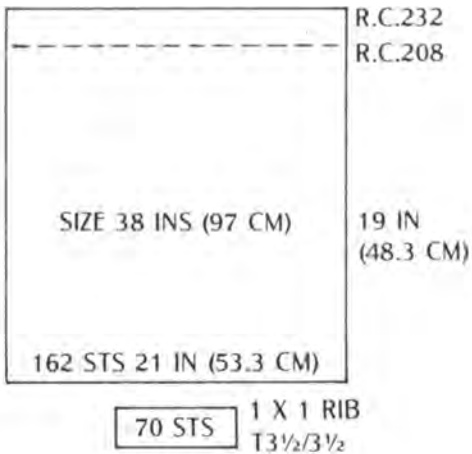
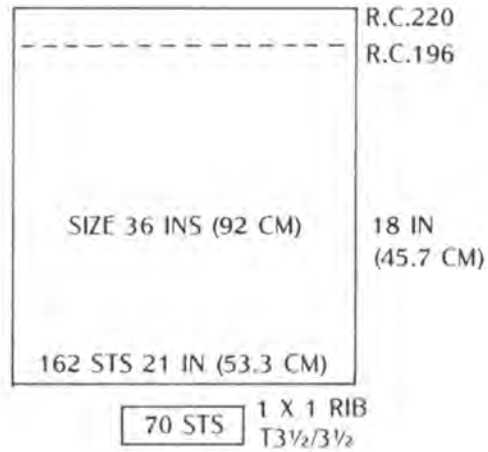
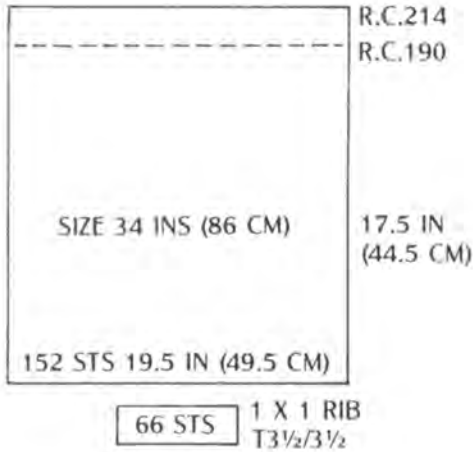

PRESS THE SLEEVES OUT TO THE MEASUREMENTS GIVEN BEFORE ADDING THE CUFFS.

## DRESS IN MONTANA COTTON

The straight dress is knitted in one strand of Montana Cotton using pushers and an **AX** setting with the left arrow key on both beds. Small sizes will require only one cone but a second cone will be required for average sizes and lengths.

Tension. 30 stitches, 107 rows = 4 ins. (10 cm.). 100 stitches = 13.4 ins. (34 cm.) 100 rows = 3.75 ins. (9.5 cm.). Tension dials approx.  $3\frac{1}{2}/3\frac{1}{2}$ .

Two pieces of knitting will be required.

Hip size

(ins.)	30	32	34	36	38	40	42	44
(cm.)	76	81	86	92	97	102	107	112
No of st.	122	128	134	140	146	158	164	176

Handle up. Blue or orange strippers.

Push up the required number of needles in a 1 x 1 rib setting.

N /N Tension  $2\frac{1}{2}/2\frac{1}{2}$ . Knit one row.

CX / CX Tension  $3\frac{1}{2}/3\frac{1}{2}$  Knit two rows.

N /N Tension  $3\frac{1}{2}/3\frac{1}{2}$  Knit one row.

R.C. 000. Bring an extra needle into work on the left of the front bed. Beginning on the right hand side, transfer the stitches according to the diagram below. Bring the pushers into work and arrange as shown.

1	1	1	1	1	)
1	1	1			) pushers
111	111	111	1		back bed needles.
11	111	111	111		front bed needles
1	1	1	1	1	) pushers
1	1	1	1		)

Put all the empty needles out of work.

Handle up. Black strippers. AX /AX. Left arrow key on both beds. Tension  $3\frac{1}{2}/3\frac{1}{2}$ .

The average length of a dress which can be bought in a shop is approximately 41 in. (104 cm.). The shorter lengths are for girls or mini dresses. Measure the length of a favourite dress to help you to decide how long you are going to knit this one. Mini dresses are becoming popular again hence the very short lengths are given.

Length ins	30	31	32	33	34	35	36	37
cm.	76	79	81	84	86	89	91	94
No of rows	802	830	856	882	909	936	964	1016
Length ins	38	39	40	41	42	43	44	45
cm.	97	99	102	104	107	109	112	114
No of rows	1016	1044	1070	1096	1124	1150	1177	1204

Cast off.

Knit a second identical piece.

### Making up

Join shoulder and side seams leaving a neck and sleeve openings.

Work one row of double crochet around the neck edge and one row of crab stitch.

Sleeve edges. Work in the same manner as for the neck edge but draw the sleeve edges in slightly on the double crochet row.

I am aware that not all knitters are able to crochet and if this is the case then there are several alternatives. Use a knitted braid trim (You may need to use two strands of Montana cotton for some kinds of braid.) or knit a stocking stitch binding using approximately 10 stitches or use a purchased trim. The knitting may be lightly ironed, if desired.

### Belt

Handle down, blue or orange strippers. Cast on for every needle rib, using ten needles on each bed. Using tension  $3/3$ , knit until the belt is the desired length, (approximately 700 rows ).



## CHILD'S SIDEWAYS KNITTED SWEATER WITH FAIRISLE BANDS

Knitted in Bramwell Fine 4 ply with fairisle bands of either Magic Fairisle or Fine 4 ply. Self punched Deco card. Tension measured over stocking stitch, 40 rows, 28 stitches = 4 ins. (10 cm.). 100 rows = 10 ins. (25.4 cm.), 100 stitches = 14.3 ins. (36.3 cm.). Tension dial approximately  $6\frac{1}{2}$  for stocking stitch,  $7\frac{1}{2}$  for fairisle. The neckline is a simple cut and sew Vee neck but on this garment the Vee shape may be outlined by the method given in the pattern.

The magic fairisle yarn used in the white sweater gives the impression of many colours knitted in one row and is an easy way of creating an unusual garment.

The measurement for ease on these sideways knitted garments (6in. or 15.25 cm.) is more than is usual for a garment knitted in the conventional direction of bottom to top. Rows do not 'give' in the same way as stitches so more ease is allowed. The sleeves are also a little longer than on other patterns to give comfortable shape. If you require a snugly fitting garment it may be advisable to knit a smaller size.

### Front

It is a good idea to use the centre of the machine as the dividing point between the body and the armhole on childrens garments although this is not possible where some larger, adult sizes are being knitted. The body stitches and the armhole stitches should be cast on separately in waste yarn. Use the method given at the front of the book to cast on for the body then put the pushers for those needles back into the blocking rail. Bring up the pushers and needles for the second section. Follow the instructions for the setting up of the pushers and for the first two rows. It is not possible to continue in the usual way by changing to N or all the needles would knit, instead, cancel the arrow key and bring all the pushers for the armhole section into the up or working position. Continue to knit in GX/BX but without the arrow key in operation, this will ensure that only the armhole stitches are knitting. When the two groups of stitches have been cast on we can continue as though they are all one section until the body has been knitted but they must be run off on waste yarn as two separate sections at the end of the piece.

Handle down. Black strippers. GX/N. Tension  $6\frac{1}{2}$ . R.C.000.

Change to main yarn and knit the first section of stocking stitch.

### Fairisle section

R.C. 000 Handle down. Black strippers. GX/BX with the left arrow key on the front bed. Tension  $7\frac{1}{2}$ . Bring up a pusher for every working needle. Set the Deco card on row number 0. Move the row tripper to the left hand side. Pass the card reader three times across the card and attach it to the lock. Set to 4.

Knit two rows main colour, 2 two rows contrast until the row counter shows R.C. 40. Twenty rows will actually have been knitted.

Park the card reader on the extension on the left hand side of the front bed. Cancel the arrow key and put all the pushers in rest position.

R.C.000. GX/N Tension  $6\frac{1}{2}$ . Knit to R.C.10.





## Neck Shaping

Handle down. Black strippers. N/N. Tension 6½/6½.

\* Transfer two stitches from the right hand side of the front bed onto the corresponding needles on the back bed. (slightly to the right.) Put the empty needles out of work. Knit one row.\*

Repeat from \* to \* until 46 stitches are working on the back bed.

R.C.33. \*\* Knit one row. Transfer two stitches from the bottom of the Vee onto the front bed. Put the empty needles out of work.\*\*

Repeat from \*\* to \*\* until all the stitches have been returned to the front bed.

R.C. 56. GX/N. Knit 10 rows to R.C.66.

R.C.000. Set the Deco card to row number 56 on the right of the card and repeat the fairisle section.

R.C.000. Knit the last section of stocking stitch.

### To run off on waste yarn.

The two groups of stitches ( body and armhole ) should be run off on two sections of waste yarn in the following way:- Make sure that the arrow key has been cancelled.

Put the pushers for one section up, leave the other section in rest position.

GX/BX. Knit several rows of waste yarn and release this section from the machine. Put the pushers in the blocking rail and the needles out of work.

GX/N Knit several rows of waste yarn over the remaining stitches and release from the machine.

## Back

Knit the back as for the front, working the fairisle panels if desired but omitting the vee shaping. Mark the end needle on the right with a length of contrast yarn at R.C 10 and R.C. 56, this will indicate the neck position when the shoulder seams are joined.

Join the shoulder seams making sure that the seams are not bulky on the armhole edges.

## Sleeves

These are knitted downwards after picking up the stitches from the armhole sections and making the piping which disguises the change of direction on some sections of the knitting.

The back bed is used. With the wrong side of the garment facing you, pick up the loops of the row of stitches in main yarn next to the waste knitting.

R.C.000. Handle down. Black strippers. N/GX. Tension 6½. Using the contrast yarn, knit 10 rows. (20 rows may be used if a wider strip of piping is required).

Pick up the stitches from the first row knitted in contrast yarn onto the same needles.

R.C.000 Change to main yarn.

## Decreasing

Take the first and second stitches from the edge onto the two pronged tool and replace the stitches onto the second and third needles, put the empty needle out of work. You may find it quicker and easier to use the single prong transfer tool to put the second stitch onto the third needle and the first onto the second. Decrease each time at both sides of the knitting.

When the required number of rows have been knitted, transfer the stitches for 1 x 1 rib.

R.C. 000 Handle up. Blue or orange strippers. N/N Tension 3½/3½.

Knit 20 rows and cast off. If you have difficulty making a neat cast off then you may like to take the stitches off onto an ordinary hand knitting needle and cast off by the handknitting method. Remove the waste yarn.

## Bottom ribs.

Knitted in 1 x 1 rib. Tension 3½/3½ for twenty rows.

Size                    22 24 26 28 30 32

Number of needles 86 92 100 106 114 120

Knit the rib and transfer the stitches to the back bed. With the wrong side of the garment facing you, hang the bottom edge of the back onto the needles already holding stitches.

Handle down. Black strippers. N/GX. Tension 7. Knit one row and cast off. Repeat for the front rib.

## Neckline

Backstitch twice round the shape of the Vee ( or machine stitch twice). Cut out the reversed stocking stitch section. Make and attach the neckband following the instructions at the front of the book.

## Grafting the side seams.

Pick up the stitches from the last row of main yarn of the cast off for the back with the right side facing you. Now pick up the stitches of the first row of main yarn of the cast on from the front piece onto the same needles with the wrong side of the garment facing you. Allow the first stitches to fall behind the latches and pull the second stitches through these. Knit one row at main tension and cast off. Repeat the process for the other side of the body. Sew up the underarm seams.

The pattern may be varied by knitting the section between the fairisle bands in the contrast yarn.

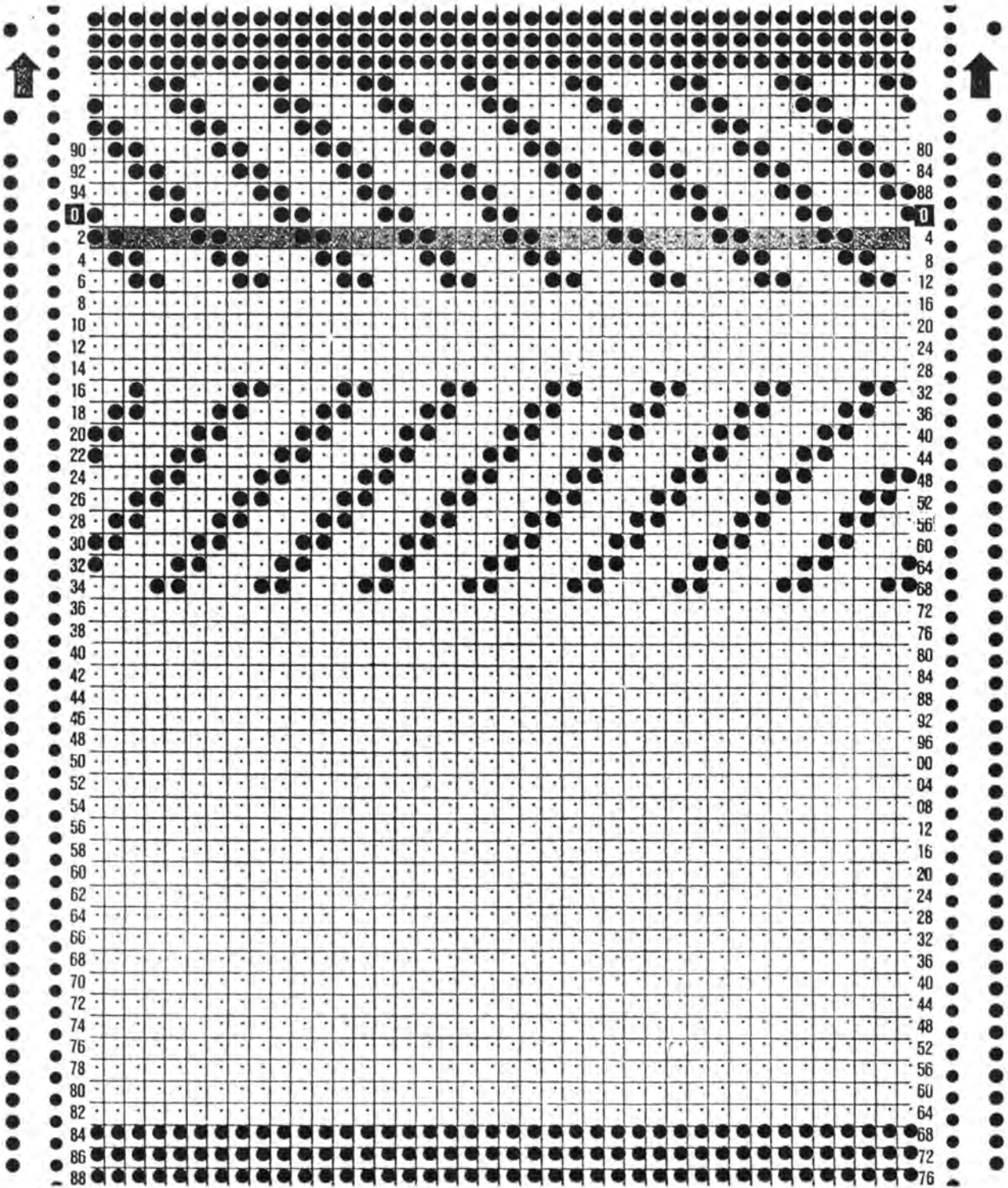

# CHILD'S SIDWAYS KNITTED STOCKING STITCH SWEATER WITH FAIRISLE BANDS

Tension 28 sts, 40 rows = 4 ins (10 cms) in stocking stitch. Tension dial approximately 6½. Fairisle tension dial Approximately 7½

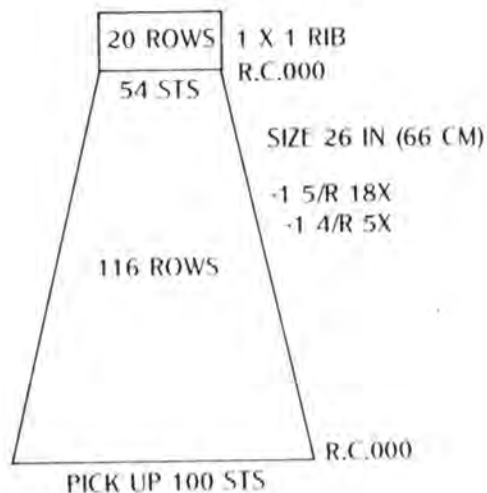
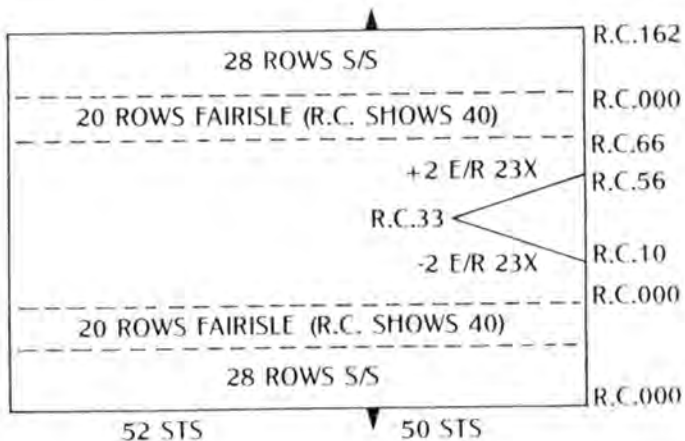
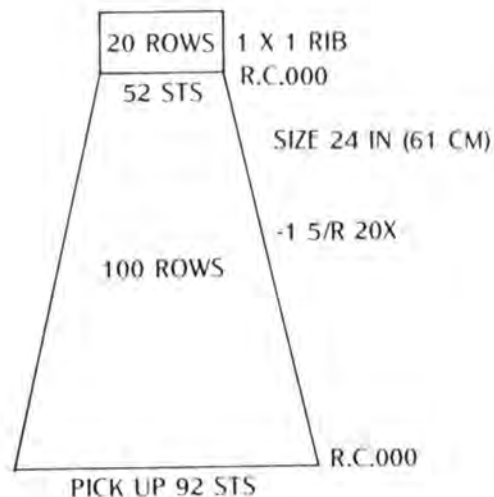
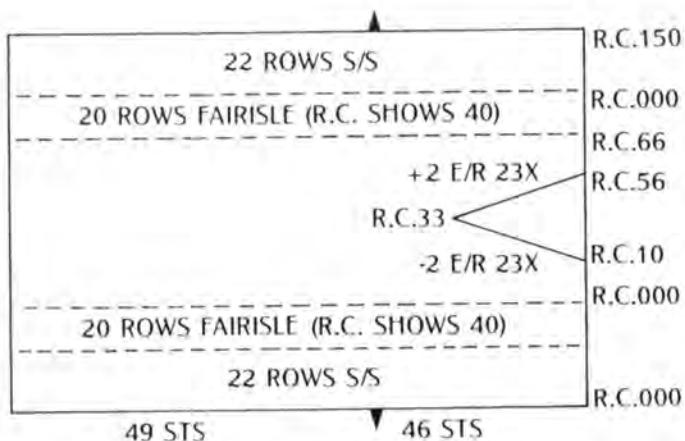
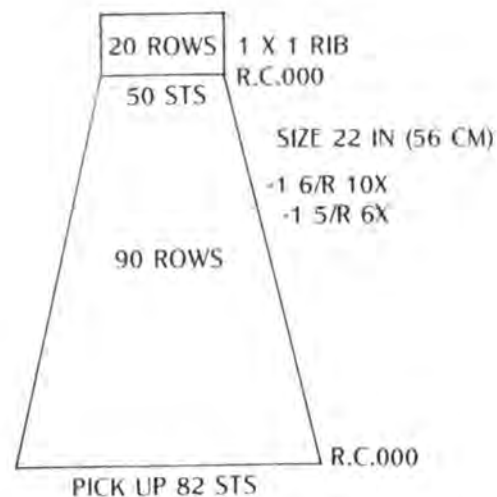
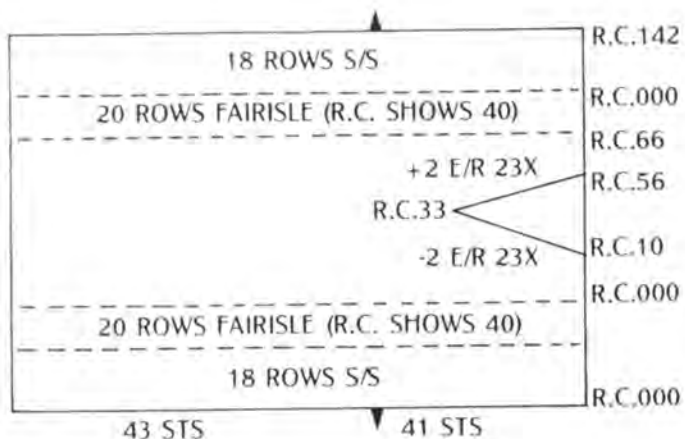

# CHILD'S SIDWAYS KNITTED STOCKING STITCH SWEATER WITH FAIRISLE BANDS

Tension 28 sts, 40 rows = 4 ins (10 cms) in stocking stitch. Tension dial approximately 6½. Fairisle tension dial approximately 7½.

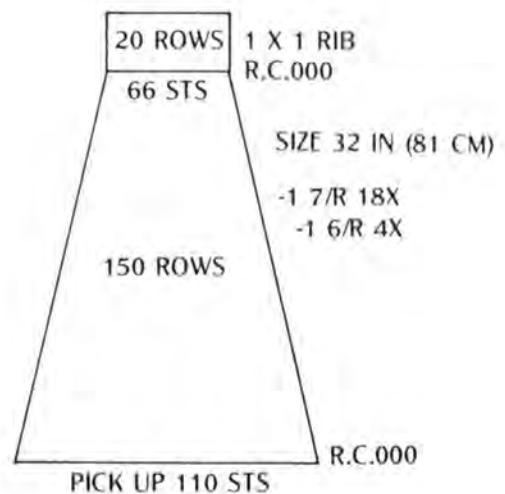
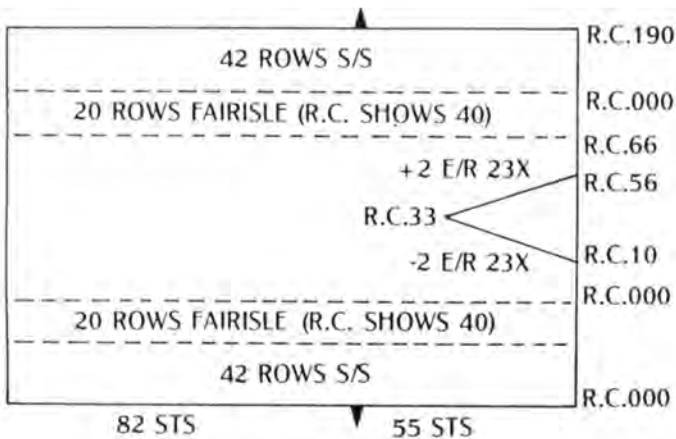
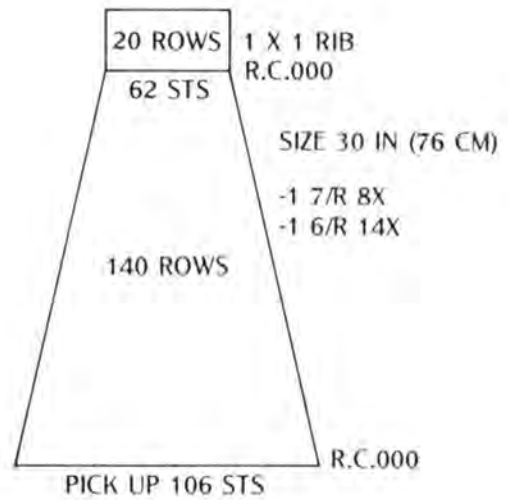
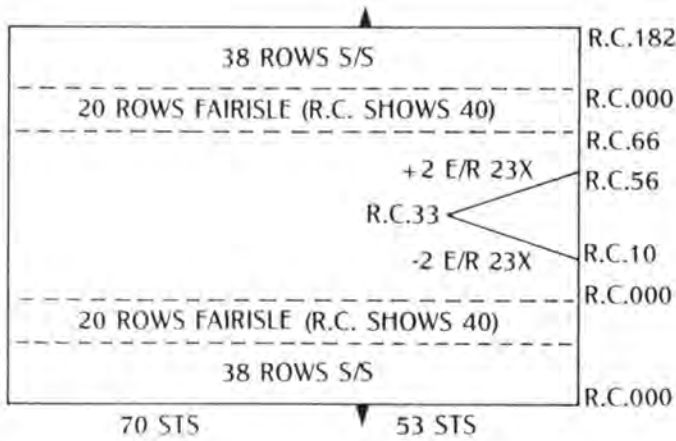
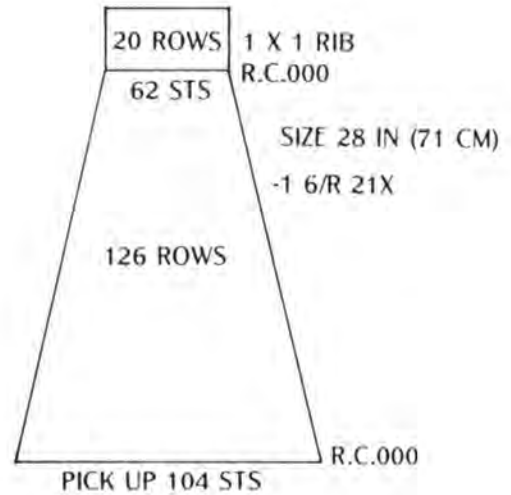
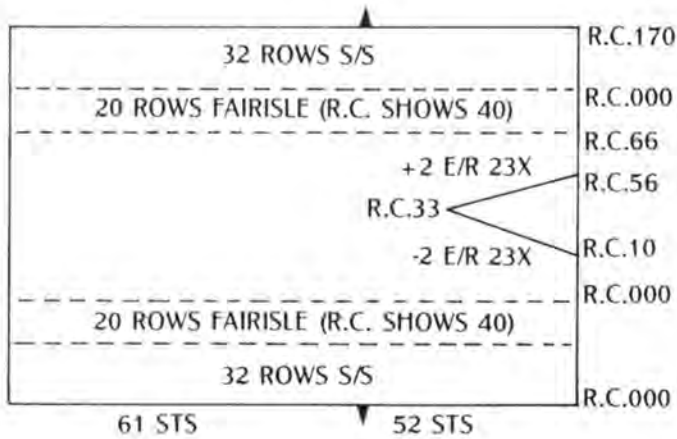



## ADULT'S SIDEWAYS KNITTED SWEATER

Knitted in 3 strands of Bramwell 2/30 yarn or in 1 strand of Bramwell Fine 4 ply.

Tension 28 sts , 40 rows = 4 in (10 cm). 100 rows = 10 in (25.4 cm). 100 sts = 14.3 ins (36.3 cms).

One strand each of black, silver grey, and white 2/30's yarn were used for this garment with the ribs and trimming knitted in three strands of black. Wind the three strands together using a cone winder. Now rewind twice, causing the yarns to twist. A yarn twister may be used, but the garment shown was made using yarn twisted by the method given above.

Please read through the instructions for the previous pattern before knitting this garment. As the instructions are basically the same except for the fairisle, it is not necessary to use up space by repeating them.

### Bottom Ribs

The bottom ribs are made in the same way but 30 rows of rib are knitted for the adult garment.

Size                      34   36   38   40   42   44

Number of needles 128 134 142 148 156 162

By studying the previous pattern you will see that it is possible to incorporate a fairisle band into the adult garment. Please remember, when inserting fairisle, that the row counter will show twice the number of rows actually knitted.

The instructions for the neckband are at the front of the book.



2/30

Fine 4-ply

# ADULT'S SIDEWAYS KNITTED STOCKING STITCH SWEATER

Tension 28 sts, 40 rows = 4 ins. (10 cms.) Tension dial approximately 6½

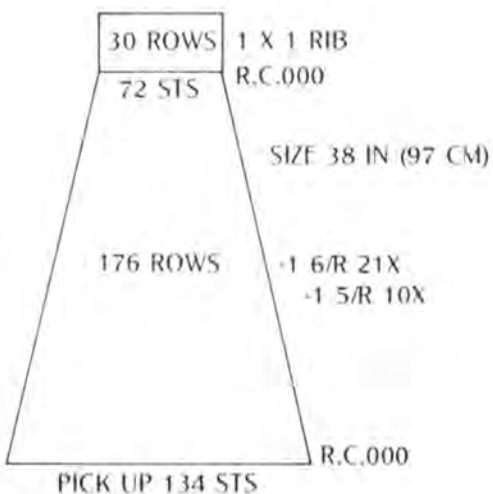
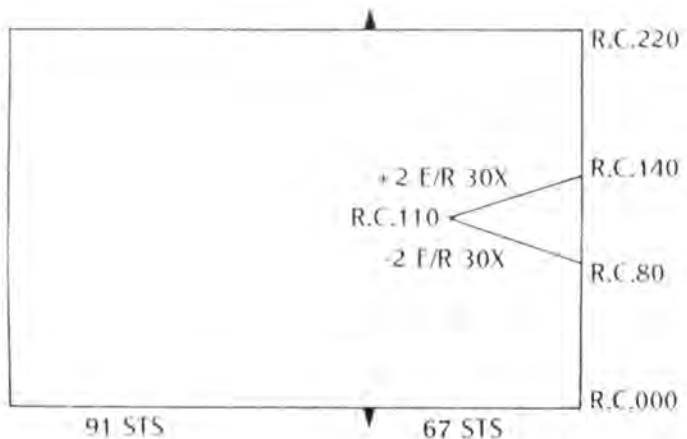
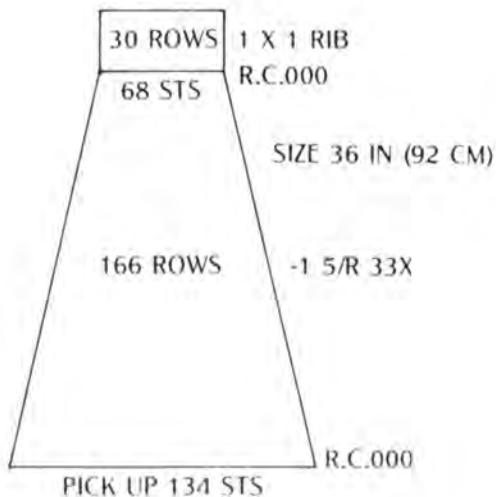
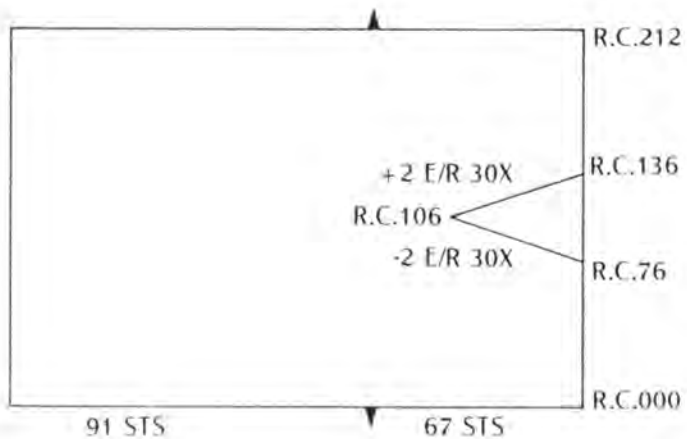
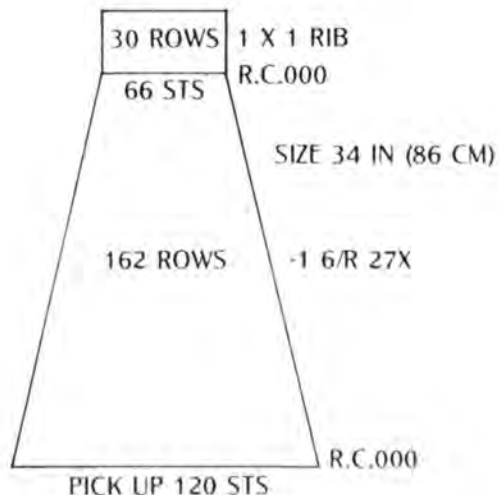
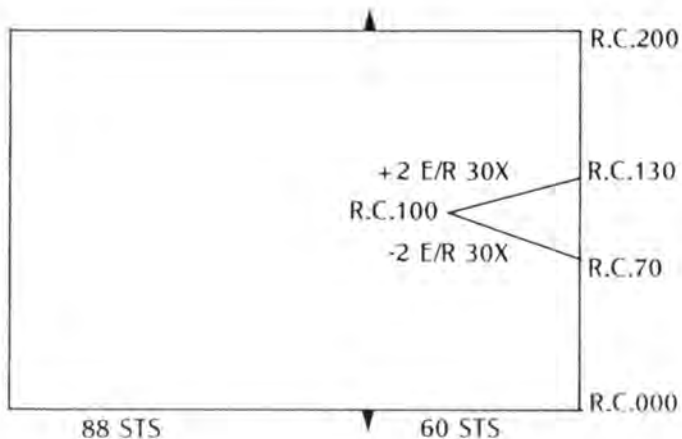

# ADULT'S SIDEWAYS KNITTED STOCKING STITCH SWEATER

Tension 28 sts, 40 rows = 4 ins. (10 cms.) Tension dial approximately 6½

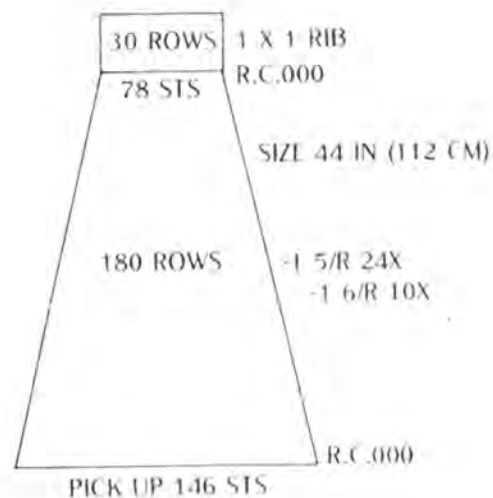
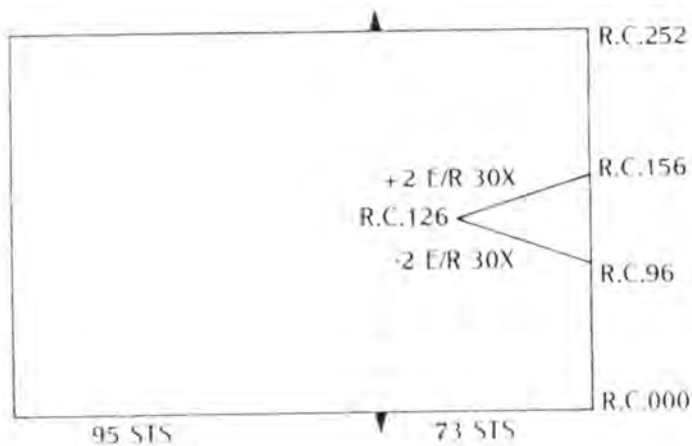
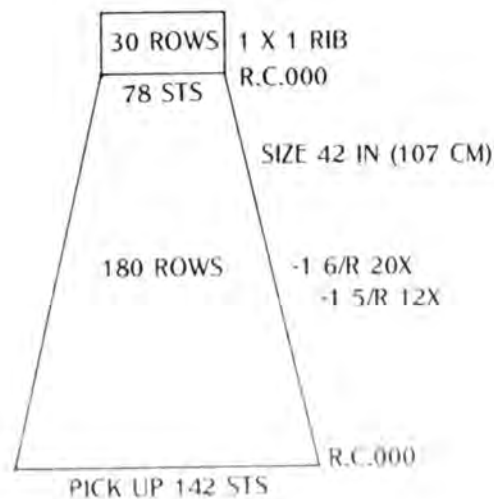
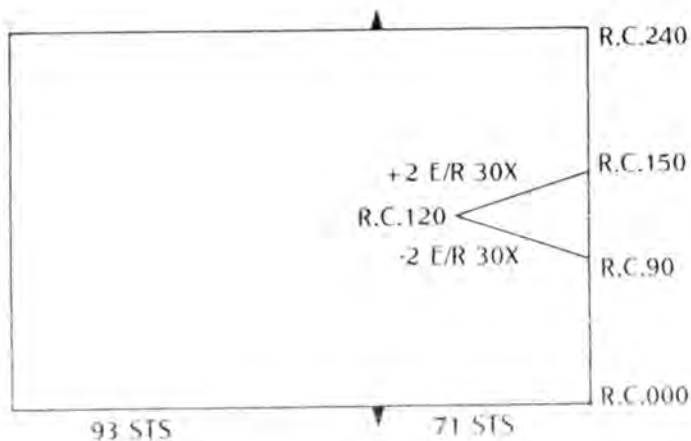
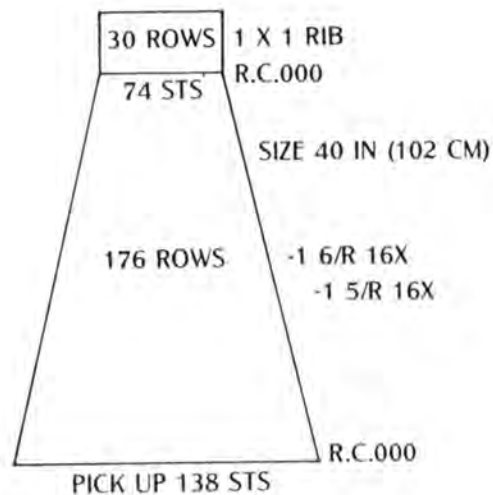
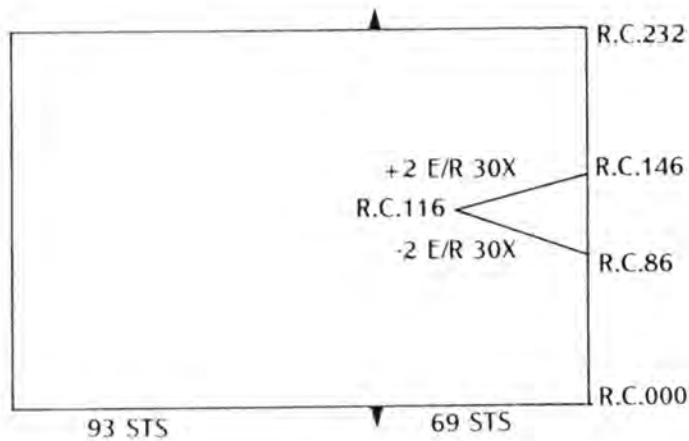

## TWO COLOUR TUCK SWEATER WITH CUT IN SLEEVE.

Tension 18 sts., 68 rows = 4ins. (10 cms.) knitted in two strands 2 / 30 in main colour and two strands in contrast colour.

100 sts. = 22.22 ins (56.4 cms.) 100 rows = 5.9 ins. (15 cm). Tension dials approx 4/4 for tuck stitch pattern. The stitches for the pattern are counted on the front bed only, although needles on the back bed will also be in work. Deco card 30 will be required.

The pattern is knitted N/AX with the left arrow key on the front bed. Two rows are knitted with the main yarn first, then two rows with the contrast colour. The ribs are made in longstitch (CX/N Tension 4/3) to give a fairly firm rib for the tuck stitch.

### Back and front alike.

Handle down. Blue or orange strippers. N/N.

Bring up the required number of needles on the front bed and the same number on the back bed for an 'every needle rib' cast on.

N/N Tension 2/2 Knit one row.

CX/CX Tension 3/3 Knit two rows.

N/N Tension 3/3 Knit one row.

CX/N Tension 4/3 Knit the required number of rows for the rib.

Bring up a pusher for every working needle on the front bed.

R.C.000 Handle down. Blue or orange strippers. N/AX left arrow key on the front bed. Tension 4/4. Put the row tripper against the edge spring on the left hand side. Bring the card reader three times across the card to register the pattern and attach it to the lock. Set to 4.

Begin with two rows of main colour then two rows of contrast. Repeat these four rows throughout. At the end of the first section of pattern the number of stitches to be cast off is shown for the front bed only, but the same number must be cast off on the back bed also. Transfer the number of stitches shown from the front bed to the back bed and cast the two sets of stitches off together. Put the empty needles out of work and their pushers into the blocking rail. Move the row tripper to the edge of the knitting on the left.

R.C. 000 Knit the second section.

When shaping the shoulders remember that, as for the armhole cast off, the number to be cast off is shown for the front bed only but the same number must also be cast off on the back bed. When only the centre number of stitches shown on the diagram is left on each bed knit one row of every needle rib (N/N) and run off on waste yarn.

### Sleeves

The sleeves are knitted in the same way as the back and front pieces. When increasing bring up a needle at each end of the knitting, on both beds, and bring up a pusher for each new needle in work on the front bed. The Deco will put the pusher in its correct place. Knit the required number of rows on the first section, place a marker thread over the end needles to indicate the position of the sleeves when making up. Knit the second section of the sleeve and cast off very loosely.

### Neckline.

This may be Vee or round neck.

Backstitch twice round the shape of the neckline (or machine stitch twice) and make a neckband according to the instructions at the beginning of the book.





## TWO COLOUR TUCK SWEATER

Tension 18 sts, 68 rows = 4 ins. (10 cms.). Tension Dials approximately 4/4

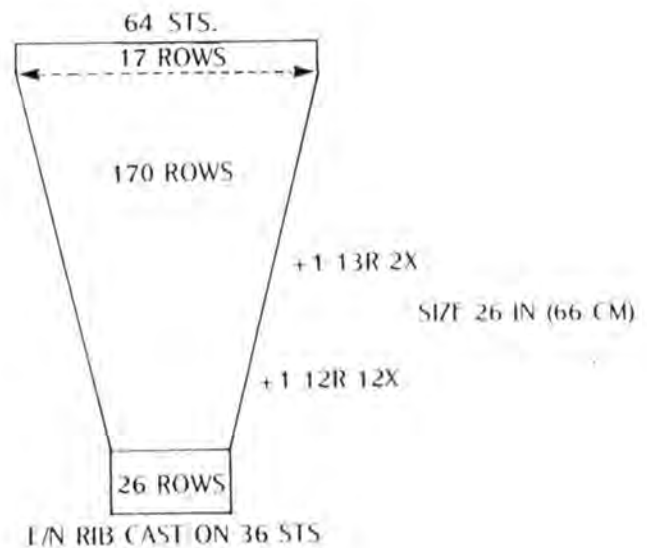
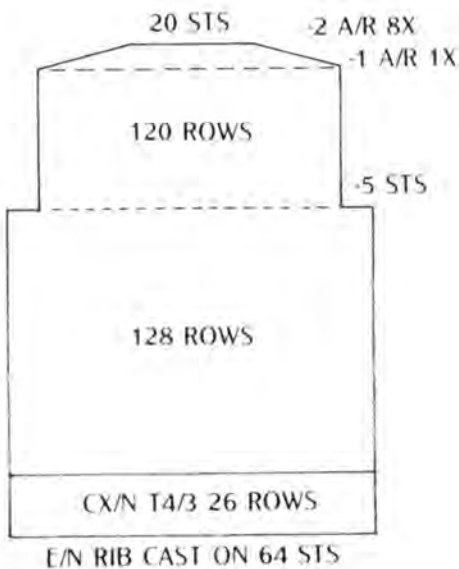
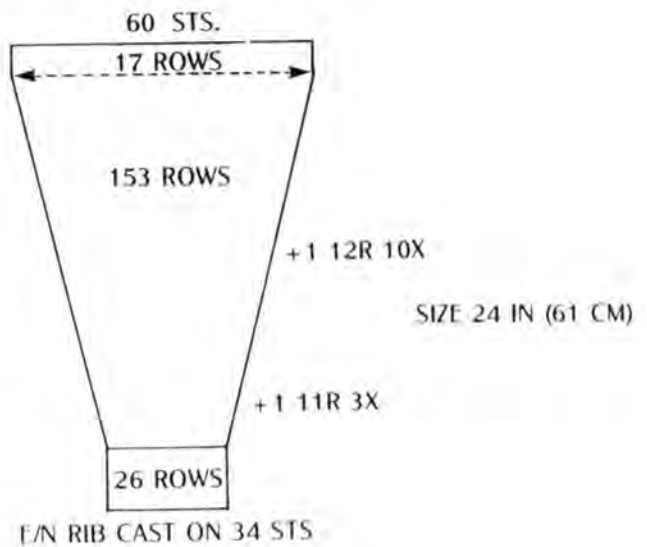
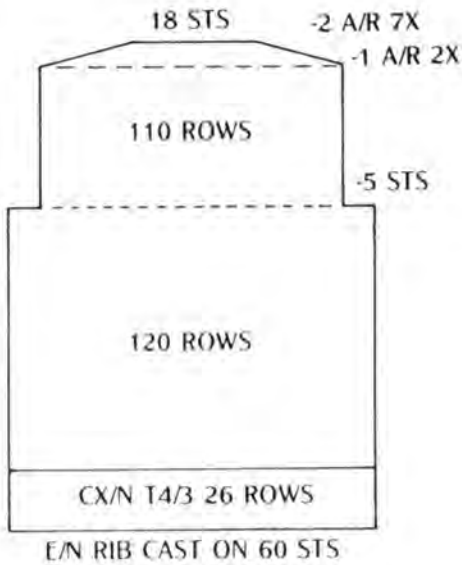
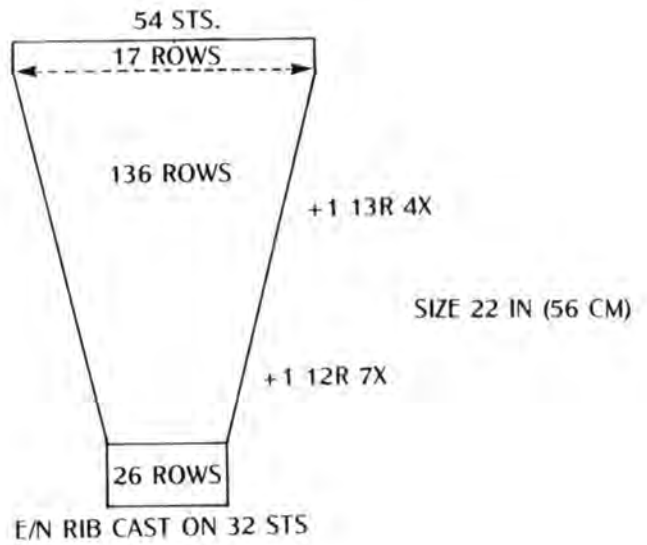
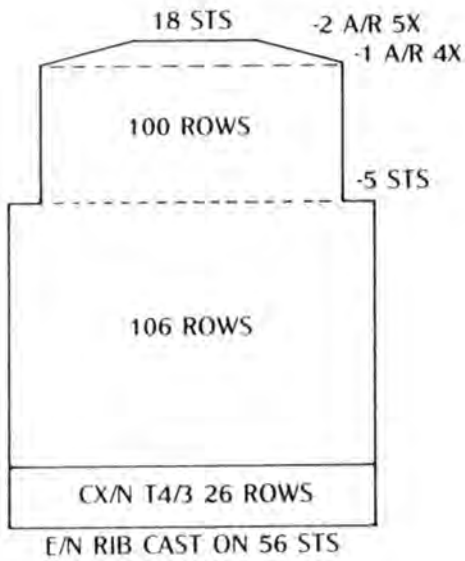

## TWO COLOUR TUCK SWEATER

Tension 18 sts, 68 rows = 4 ins. (10 cms.). Tension Dials approximately 4/4

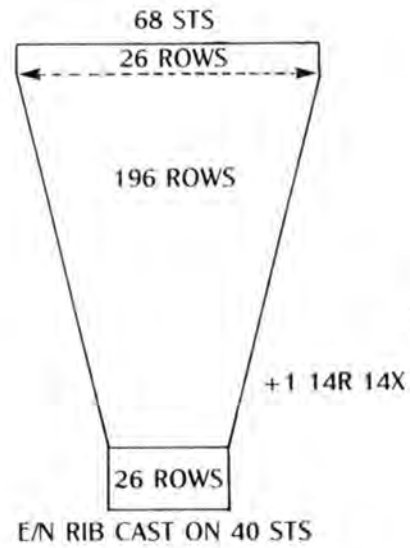
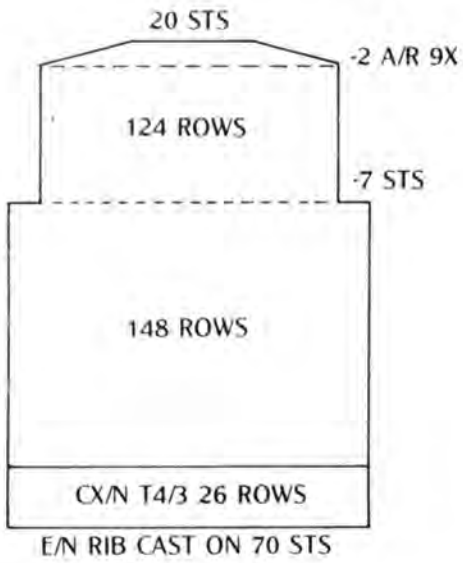

SIZE 28 IN (71 CM)

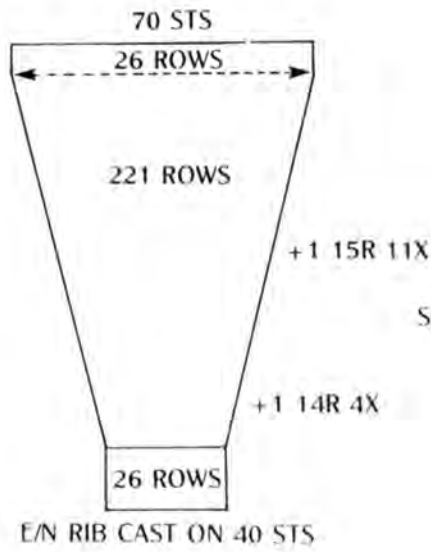
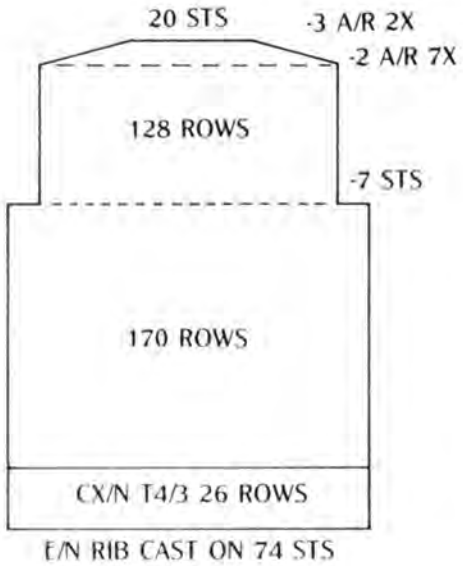

SIZE 30 IN (76 CM)

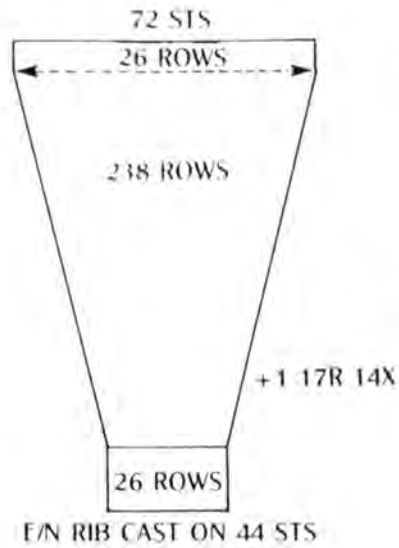
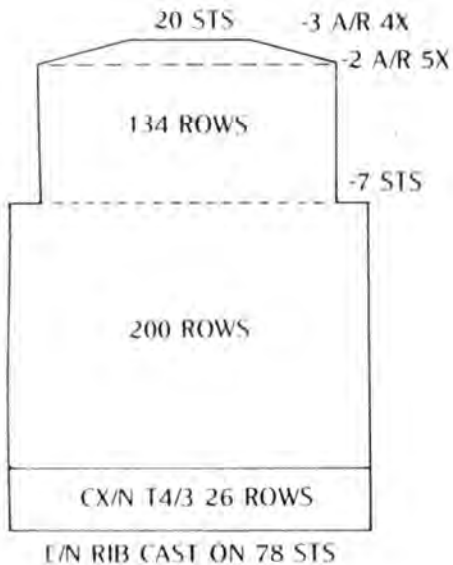

SIZE 32 IN (81 CM)

## TWO COLOUR TUCK SWEATER

Tension 18 sts, 68 rows = 4 ins. (10 cms.). Tension Dials approximately 4/4

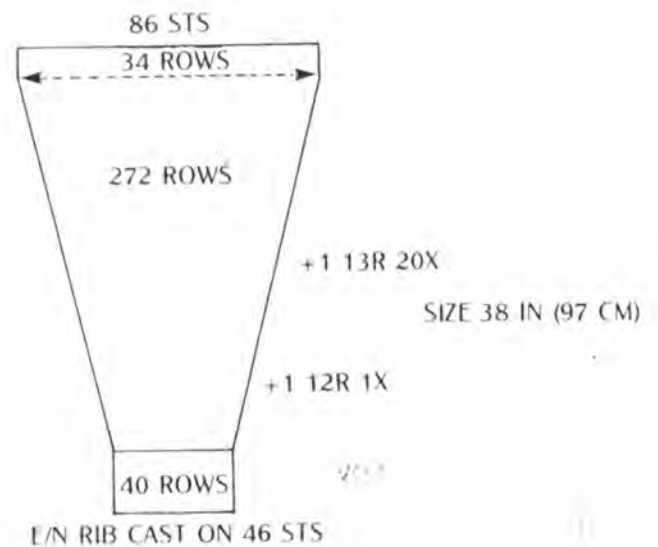
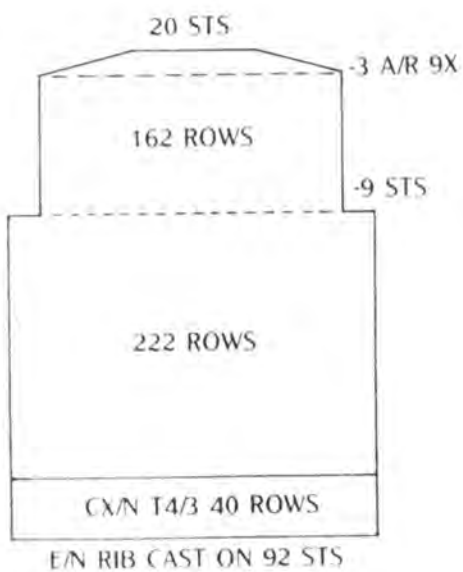
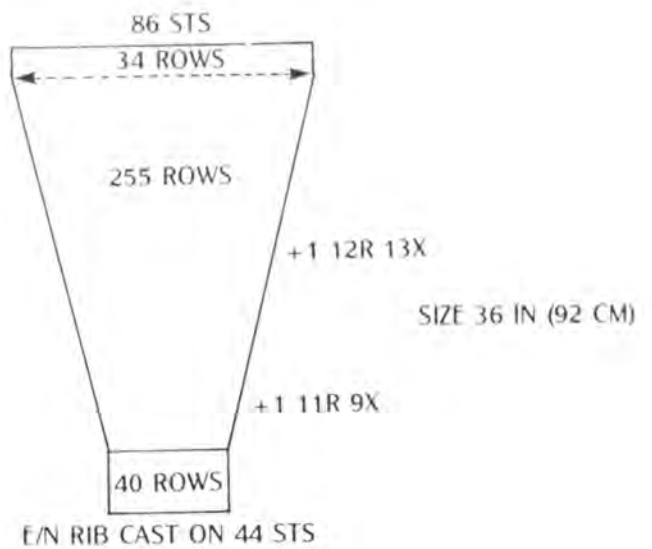
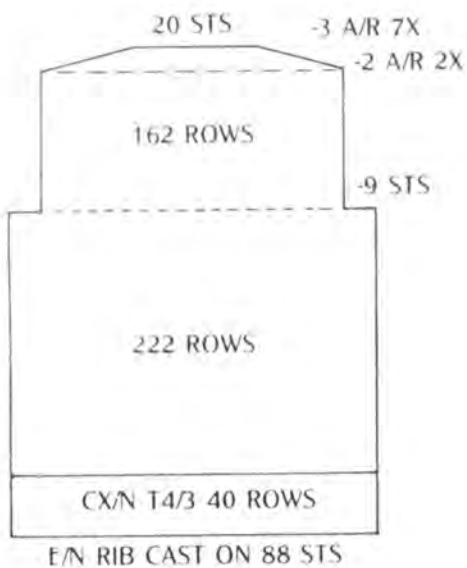
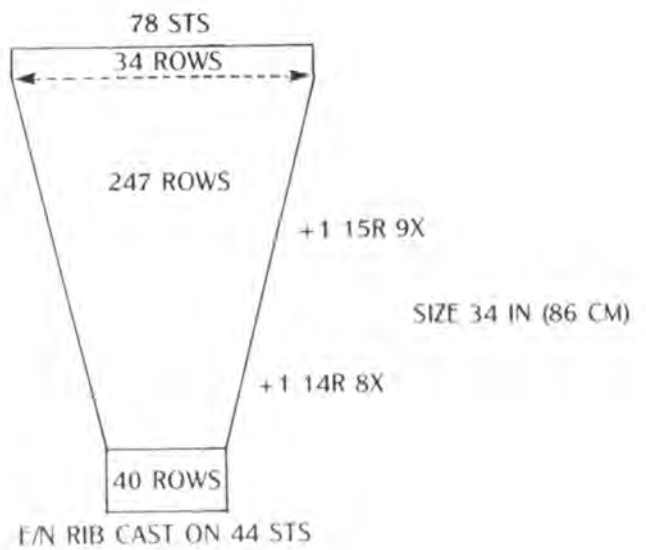
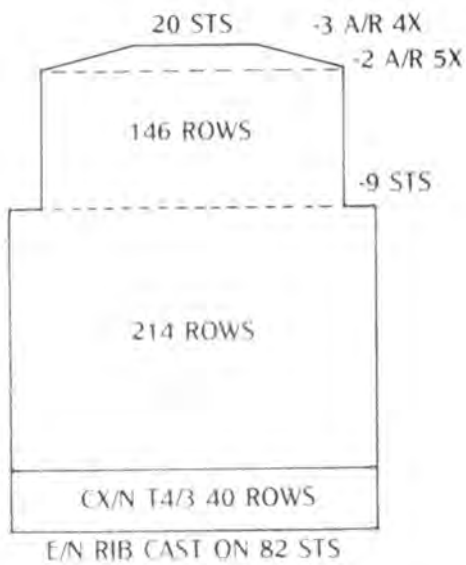

## TWO COLOUR TUCK SWEATER

Tension 18 sts, 68 rows = 4 ins. (10 cms.). Tension Dials approximately 4/4

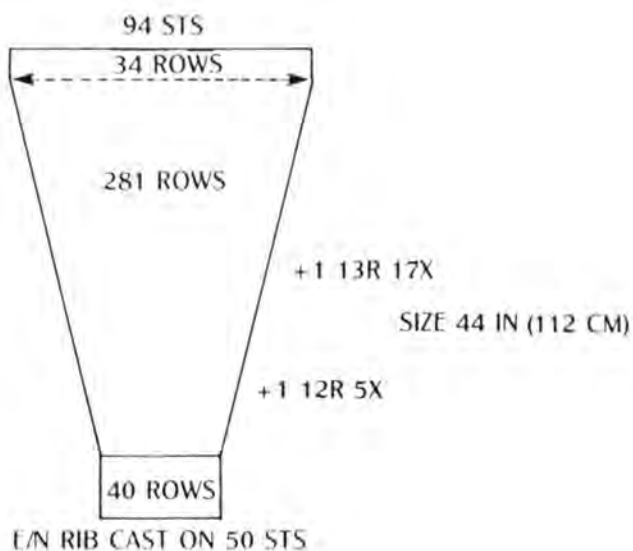
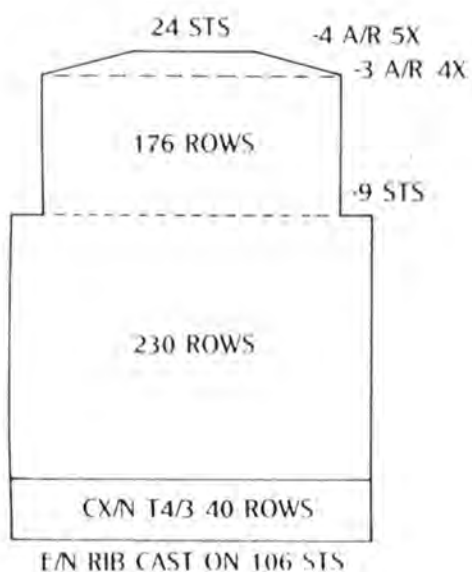
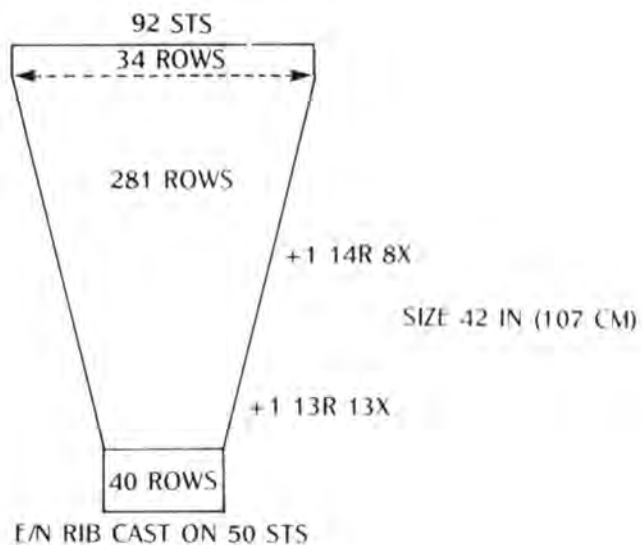
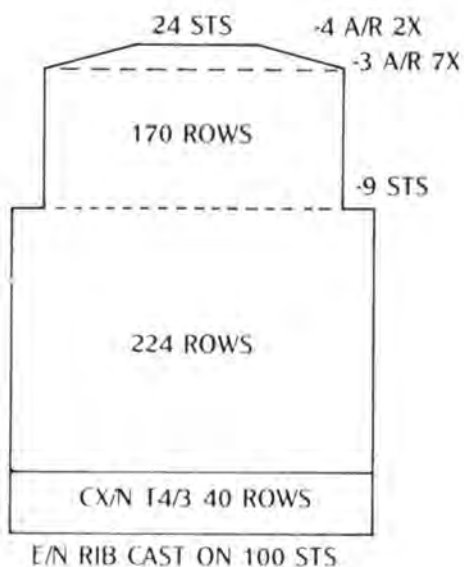
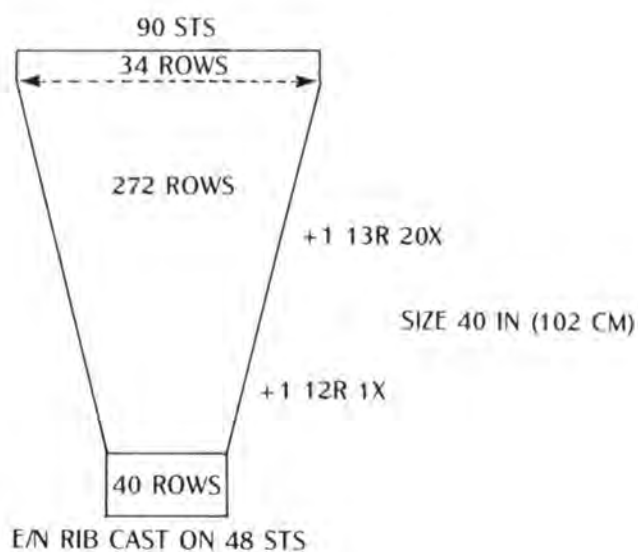
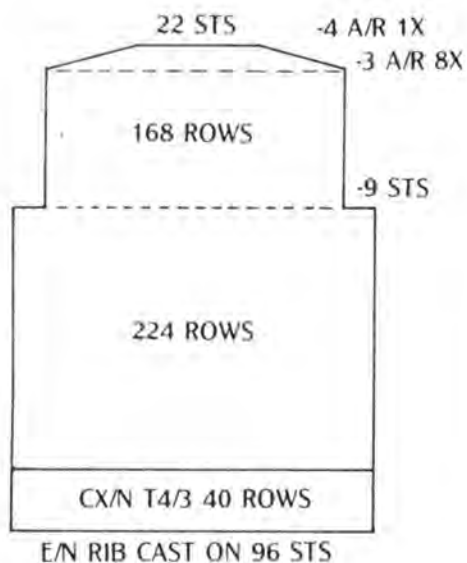



We are frequently left with oddments of yarn which could be used up if only we could find a pattern for small items. Here are some ideas for bazaar items which can be quickly made using up small amounts of yarn.

### SNOWMEN

This may be knitted in three sizes. Numbers for stitches and rows are given first for the large size. Medium and small sizes are given in brackets.

Tension piece not required. White, red and black (or brightly coloured as a substitute for black) 4 ply yarn will be required, also a small piece of black felt.

Set up 80 (60, 40) needles for 1 x 1 rib. Handle up. Blue or orange strippers. White yarn.

N/N Tension 2/2 Knit one row.

CX/CX Tension 3/3 Knit two rows.

N/N Tension 3/3 Knit one row.

R.C.000. N/EX Tension 4½/4½ Knit to R.C.114 (76, 57)

N/N Tension 3/3. Knit 6 (4, 3) rows to R.C.120 (80, 60)

N/EX Tension 4½/4½ Knit 30 (20, 16) rows to R.C.150 (100, 76)

Change to black yarn and black strippers.

N/GX Tension 7 on the back bed. Knit 20 (14, 10) rows to R.C. 170 (114, 86) (this makes the brim of the hat.)

N/EX Blue or orange strippers. Tension 4½/4½ Knit 49 (35, 25) rows to R.C.219 (149, 111).

N/N Tension 4½/4½ Knit one row to R.C. 220 (150, 112)

Break off the yarn and using a darning needle thread the yarn through the stitches. Draw up and fasten off firmly. Sew up the back seam.

### Scarf.

Handle up. Blue or orange strippers. N/N. Cast on 10 (8, 6) stitches in 1 x 1 rib in red yarn. Tension 4/4 Knit 140 (100, 70) rows. Cast off.

Stuff the hat very lightly and the head and body firmly. Gather and sew up the base of the body. Fringe the scarf and tie around the neck.

EYES ● ● NOSE ▲ MOUTH ☾ THREE BUTTONS ●

Cut the face details and three buttons from the felt and sew on.

Make a small bobble and fix to the top of the hat. If desired the hat may be made in gaily coloured stripes.

### HOT WATER BOTTLE COVER

To fit an average size hot water bottle. Oddments of 4 ply yarn required.

Tension piece not required. Handle up. Blue or orange strippers.

Arrange 46 needles for 1x1 rib. N/N Tension 3/3. Knit one row. CX/CX Tension 3½/3½ Knit two rows.

N/N. Tension 3½/3½. Knit 20 rows of 1x1 rib.

Bring up a pusher for every working needle on the front bed.

N/AX Left arrow key on the front bed. Tension 5½/5½. Knit 300 rows.

N/N Tension 3½/3½ Knit 20 rows of 1x1 rib.

Cast off loosely. Sew up the side seams. Fold half of the top rib to the inside and catch down. The cover looks very small but it will stretch because of the heat of the hot water bottle. Can be knitted in random or regular stripes.

### GOLF CLUB COVERS

Tension piece not required.

Use 1 strand of double knitting or 1 strand of 4ply with a strand of 2/30 or Silky added.

Handle up. Arrange 50 needles for 1 x 1 rib. Blue strippers.

N/N Tension 4/4. Knit 1 row. CX/CX Tension 5/5. Knit 2 rows N/N Tension 5/5. Knit 2 rows

EX/EX Tension 6/6. Knit 80 rows. N/N Tension 6/6. Knit 40 rows. EX/EX Tension 6/6. Knit 80 rows.

N/N Tension 6/6. Knit 4 rows.

Break off the yarn and thread the tail through a tapestry needle. Thread this yarn through the stitches, releasing them from the needles at the same time. Gather up and fasten off securely.

Fold the fabric in half lengthways and sew down the long edge. Pull half of the tube back over itself, making a double fabric. Using the tail end of the yarn from the cast on, thread a tapestry needle and gather up the cast on edge. Fasten off securely.

Bobble. Wind the yarn around a small notebook or similar until there is enough for the bobble. Thread several lengths of yarn through the hank and tie very tightly. Cut the loops opposite to the tie. Shake the bobble then trim with the scissors until the pieces of yarn are all the same length. Fasten to the top of the cover. If required sew felt numbers onto the covers.







2 ends 2/3 TUCK STITCH TOP AND SWEATER <sup>92</sup> 1 strand  
Yvette



SKIRT IN ARTISTIC WITH INTARSIA TOP



CHILD'S SIDWAYS KNITTED SWEATER

Fine 4-ply with Fairisle



TWO COLOUR TUCK SWEATER

2/30 100% acrylic  
2 strands





**DRESS IN MONTANA COTTON**



**STOCKING STITCH SWEATERS WITH CUT IN SLEEVES**  
*Fine 4-ply*



**TUCK STITCH SWEATERS IN TWO COLOURS**



**JACQUARD JACKET IN DUOSPUN**



**Published by Metbury Designs 1987**  
**Printed by B & D Print Services Limited, Rawcliffe House, Moss Side Industrial Estate**  
**Leyland, Lancashire, England, United Kingdom, PR5 3QN. Telephone: (0772) 435050/424592**