

# MACHINE KNITTING CHIC

**a Sabrina**  
PUBLICATION

**FASHION DESIGNS  
FOR KNITTING MACHINES**

**ELEGANT  
SPORTY  
CASUAL**



**FANTASTIC DESIGNS**  
**MANY IDEAS AND SUGGESTIONS**

**Simple Instructions · Telephone Helpline**

ISSN 1015-7948



9 771015 794000

# Contents

Dear readers,

machine knitting is more popular than ever and for this reason, we have tried harder than ever to fulfil your wishes. Exciting sweaters, elegant colour and yarn mixtures and practical items for daywear are waiting for you!

Best wishes  
Your Editor



Interesting geometries

*Christl Haefele*



Chic lace patterns



Bewitching yarn mixtures



Knit-purl patterns with imagination

This magazine is published by **BPV Medweth & Co.**, Gewerbezone Eichli 29, CH-6370 Stans.

**Publishing Directors:** H. + E. Medweth. **Editorial:** Christl Haefele. **Design:** Ch. Haefele and C. Grube. **Desk editor:** M. Leiblinger. **Distribution:** BPV Medweth & Co., Gewerbezone Eichli 29, CH-6370 Stans. Distributed in Great Britain by: MMC, Magazine Marketing Company, Octagon House, White Hart Meadows, Ripley, Woking, Surrey GU23 6HR. Tel. 0483 - 211222. Printed in West Germany by OZ-Druck- und Verlags-GmbH Rhelinfeld. Copyright 1991 by BPV Medweth & Co., CH-6370 Stans.

All models are under unlimited copyright protection ©. Commercial copying prohibited. Publishers and editors assume no liability for the unrequested contribution of photos, designs and manuscripts.



If you have any queries about any of the patterns in this issue, please write to:

**READERS' SERVICE**  
7 Laurels Avenue  
Bangor-On-Dee  
Wrexham, CLWYD, LL13 0BB

For urgent enquiries you can telephone Monday to Friday from 6 pm to 9 pm.  
Tel: (0978) 780 354

Abbreviations Page 17  
Yarn manufacturers Page 42  
Measurements Page 44

Photos Peter Münnich, Styling Gabriele Hagen-Klotz, Hair - Make up Steven Gould



Lace in pastels, suitable for everybody. If you like stronger colours, change to your own favourite. For example, white Angora and black cotton.

PURPOSEFUL SIMILARITY – DIFFERENT EFFECTS



Model 2, Size 12 - 16

Two models as proof,  
that different tech-  
niques and yarns or  
different colours give  
the same design a  
new look.



Model 3, Size 12 - 16



Model 4, Size 12/14 (16/18)

**WHITE SUITS ALWAYS - DAY OR EVENING**



These white sweaters are stars in the city as well as on special occasions. Angora with simple white flowers and almost invisible details are partners in creating wonderful effects.

Model 5, Size 12 - 16



Triangles to the fore!  
Choose your own favourite.  
On the left, sharp, clear  
intarsia. On the right soft  
Angora with a small lace  
pattern.

Model 6, Size 12/14 (16/18)



AND PATTERNS

UNUSUAL – RED WITH COLOURS, GOLD

Model 7, Size 12/14 (16/18)





Model 8, Size 12/14 (16/18)

**BLACK - WHITE**

**SPORTY IN BLUE AND CLASSIC**

Model 9, Size 16 - 20



For everybody but not ordinary – simple but with style, blue is in fashion. Cool graphics are also very attractive.



Model 10, Size 12 - 16

**TWO FACES**

**FASHION COLOURS WITH**

On the left an elegant version in quality yarns. On the right a basic sweater, that will change its mood with different accessories.

Model 11, Size 10/12 (14/16) (18/20)



Sweater and jacket either on their own  
or in matching colours as a twinset.  
Fun and exciting. For the evening, use  
Lurex for the patterns.



**THE SKIN**

**BLACK IS BEAUTIFUL, TWINS UNDER**



Sweater with Angora yoke to flatter you. Turquoise with white and a hint of gold guarantees good humour.



Model 14, Size 12 - 16



# Instructions

On the following pages you will find all the instructions, charts and diagrams for the models under their relevant numbers.

It is possible to knit some of the designs by hand. Please use our Reader Service and telephone Mondays to Fridays between 6pm and 9pm or write to the address given.

## Abbreviations:

|            |                          |
|------------|--------------------------|
| st(s)      | = stitch(es)             |
| R          | = row(s)                 |
| alt.       | = alternate              |
| C          | = colour                 |
| COL        | = carriage on left       |
| COR        | = carriage on right      |
| cont.      | = continue               |
| decr.      | = decrease               |
| incr.      | = increase               |
| rep.       | = repeat                 |
| N          | = needle(s)              |
| MB         | = mainbed                |
| RB         | = ribber bed             |
| st.st.     | = stocking stitch        |
| HP         | = holding position       |
| WP         | = working position       |
| NWP        | = non-working position   |
| UWP        | = upper working position |
| RC         | = row counter            |
| TD         | = tension dial           |
| 000        | = set RC to 000          |
| MT         | = main tension           |
| RT         | = rib tension            |
| rem        | = remaining              |
| trans.     | = transfer               |
| m.         | = metre                  |
| cm.        | = centimetre             |
| dc         | = double crochet         |
| crabstitch | = dc from left to right  |

Numbers on patterns denote measurements in centimetres

## MODEL 1 SWEATER WITH LACY SQUARES

**Size:** 12/14 (16/18). Instructions for the larger size are in brackets. One figure only applies to both sizes.

**Machine:** Suitable for standard gauge machines with ribber and intarsia carriage. We used a Brother KH 892.

**Materials:** SCHACHENMAYER "Angora" (70% Angora, 20% wool, 10% polyamid, 85m/25g) approx. 350(375)g turquoise. "Bagnola" (100% cotton, mercerised, 180m/50g). 150g turquoise.

The yarn is available by mailorder from Christl Haegele, Burg-Windeck-Str. 4b, 7580 Bühl/Baden, Germany. Send Eurocheque for DM 317.50 (337.50) incl. postage.

**Tension:** 27 sts and 35 rows = 10cm in Angora. TD. approx. 10.

**Ribs:** 1/1 rib at TD approx. 3.

**Lacy squares:** Knitted in intarsia technique in cotton over 20 sts and 28 rows. Knit 2 rows. \* Transfer every 2nd st to the left, leaving empty N in WP. Knit 4 rows. Transfer every 2nd to the right, leaving empty N in Wp. Repeat from \*.

**Arrows** on diagrams denote direction of knitting.

**Front:** With cotton cast on 128(132) sts for 1/1 rib and knit 50 rows. Transfer all sts to MB, incr. to 142(152) sts. Set RC 000. Continue in Angora and work lacy squares in intarsia with cotton over centre sts on rows 7 - 34, 39 - 66 and 71 - 98. AT THE SAME TIME, when RC shows 88, shape armhole. Cast off at each side on alt. rows 4 sts once, 3 sts once(twice), 2 sts once and 1 st twice = 120(124) sts. At RC 114, make a tuck by picking up the loops of the sts from 10 rows below and putting them on the needles. Reset RC 104. At RC 109, work in intarsia and cotton, one lacy square in centre and one square at each side with 4 sts Angora in between. At RC 136, continue in Angora st st to RC 168. Shape neck. Cast off centre 18 sts and knit each side separately. At neck edge cast

off on alt, rows 5 sts once, 4 sts once, 3 sts once, 2 sts once and 1 st twice. Cast off rem. 35(37) sts for shoulder at RC 186. Repeat for other side.

**Back:** Knits as for front to RC 178 and shape neck. Cast off centre 24 sts and knit each side separately. At neck edge cast off on alt. rows 6 sts once, 4 sts once and 3 sts once. Cast off shoulder sts as on front.

**Sleeves:** Cast on with waste yarn 70 sts and knit several rows. Change to Angora and st st. Increase 1 st at each side on every 4th row 21 times and on every 3rd row 20 times = 152 sts. AT THE SAME TIME, when RC shows 72, stop RC and knit 10 rows without increasing. Pick up loops from 1st of these rows and hang on same needles. Set RC and continue increases. Knit a

lacy square over centre sts between rows 77 and 104, as described above. At RC 148, shape sleeve top. Cast off at each side on alt, rows 1 st 4 times and 2 sts twice (1 st 8 times) = 136 sts. Cast off at RC 160(164).

**Cuffs:** Pick up 52(56) sts from lower edge of sleeves and hang on needles. Knit 1 row in Angora. Transfer sts for 1/1 rib and hang comb and weights. Change to cotton and knit 34 row in rib. Cast off.

**Neck trim:** Knit 1 strip each in cotton and Angora over 8 sts and 190 rows. Cast off.

**Finishing:** Close shoulder seams. Twist the strips together and sew to neckline. Set in sleeves and close rem. seams.

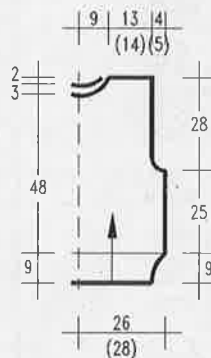

1/2 front and back

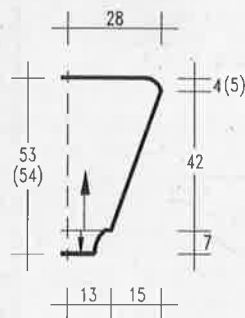

1/2 sleeve

Use yarn of similar meterage when substituting yarns!

# MODEL 2

## SIDEWAYS SWEATER WITH PLEATS

**Size:** 12 - 16.

**Machines:** Suitable for chunky machines with ribber and intarsia carriage. We used a Brother KH 230.

**Material:** PHILDAR "Coton d'Egypte" (100% cotton, 85m/50g) approx. **350g** Ocean. **200g** each in Glycine and Fidji. "Mogador" (82% viscose, 12% acryl, 6% polyester, 86m/50g) approx. **100g** Agent. "Angora" (70% Angora, 30% lambswool, 33m/10g) approx. **70g** Blanc. "Sunset" (65% acetate, 35% polyester, 160m/20g) approx. **60g** Agent. Silver beads and sequin strip. Crochet hook 4mm.

**Tension:** 19 sts and 26 rows = 10cm at TD approx. 7 over intarsia.

**Ribs:** 2/2 rib at TD approx. 0.

**Intarsia:** Knitted foll, the chart, on rows 20, 40 and 70 knit a pleat as follows. Disengage RC and knit 10 rows in revelant yarn. Pick up loops from the first of these rows and hang on same needles. Pull all needles forward and knit 1 row. Engage RC and continue from chart. The 1st and 3rd pleat are knitted in Angora and the 2nd pleat in Sunset used triple.

**Arrows** on diagrams denote direction of knitting:

**Front with 1/2 sleeves:** Cast on in waste yarn 35 sts and knit several rows. Set RC 000 and knit from chart, reading increases at right edge from chart. At RC 128, shape neck at left edge as shown with lower line. At RC 230, knit second sleeve, reading the chart from row 80 downwards. At RC 310, release rem, 35 sts on waste yarn.

**Back and 1/2 sleeves:** Knit as for front, except for using the higher neckline shaping.

**Cuffs:** Close upper sleeve and shoulder seams. Pick up sts from lower sleeve edge, reducing them to 48 sts. With Coton d'Egypte knit 1 row st st. Transfer for 2/2 rib and knit 30 rows. Cast off.

**Welts:** Pick up lower edge of back or front and hang on 90 needles. Knit 1 row st st. Transfer for 2/2 rib and knit 30 rows rib. Cast off.

**Finishing:** Sew on beads and sequin strip. Close rem. seams. Crochet around neckline with 1 row dc's and 1 row crabstitch.

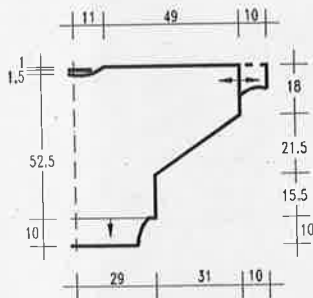

1/2 front and back with sleeve

Chart (Front with 1/2 sleeve)

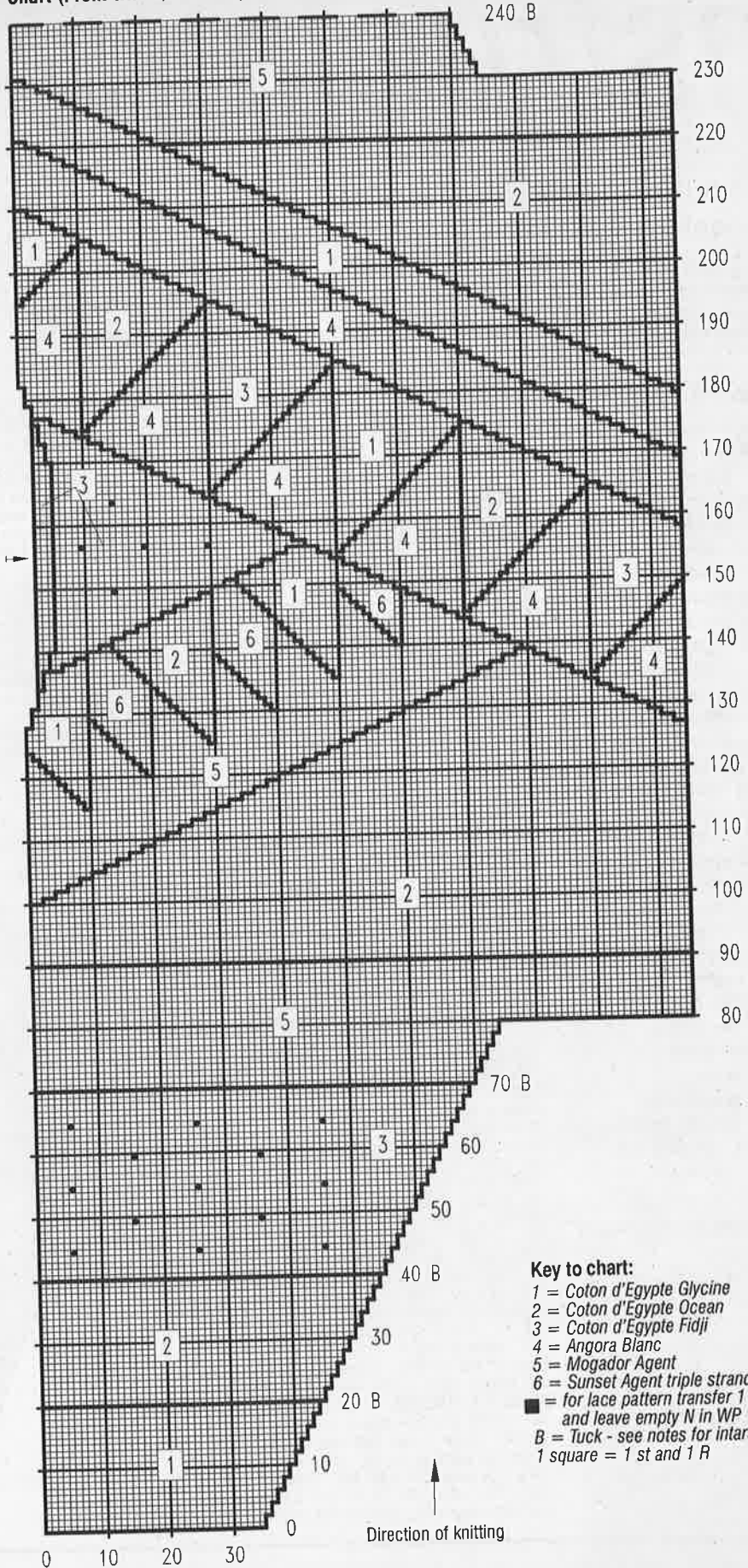

**Key to chart:**

- 1 = Coton d'Egypte Glycine
- 2 = Coton d'Egypte Ocean
- 3 = Coton d'Egypte Fidji
- 4 = Angora Blanc
- 5 = Mogador Agent
- 6 = Sunset Agent triple strand
- = for lace pattern transfer 1 st to right and leave empty N in WP
- B = Tuck - see notes for intarsia
- 1 square = 1 st and 1 R

# 3

## MODEL PURPLE GARTER STITCH SWEATER

**Size:** 12 - 16.

**Machines:** Suitable for Brother Electronic machines with garter carriage. On other standard gauge machines with ribber, the pattern may be knitted by transferring stitches.

**Material:** WOLL SERVICE "Cablé 30" (100% cotton, mercerised, 140m/50g) approx. 650g purple.

Available by mailorder from Christl Haegele, Burg-Windeck-Str. 4b, 7580 Bühl/Baden, Germany. Send Eurocheque for DM 84.50 incl. postage.

**Tension:** 26-27 sts and 34 rows = 10cm over garter stitch pattern at TD 9\*.

**Ribs:** 2/2 rib at TD approx. 5. Stitch World pattern 534.

**Garter stitch:** Stitch World pattern 537.

**Main pattern:** Mark mylar sheet or program machine. Filled squares denote knit sts.

**Lace pattern:** After row 4 of the area, transfer centre stitch to the right. Leave empty N in WP. Transfer every 6th st either side across the row. Knit 8 rows. Repeat transfers, using needles in centre of previous transfer.

**Arrow** on diagrams denote direction of knitting.

**Front:** Cast on 146 sts and knit 30 rows in 2/2 rib. Increase stitches to 166 and set RC 000. Knit in main pattern. In upper V-shaped area, make lace holes at 3 or 4 stitch intervals every 6th row. At RC 94, mark both edges for armholes. At RC 190, change to garter stitch and knit 10 rows. Cast off.

**Back:** Knit as for front, reversing the pattern.

**Sleeves:** Close shoulder seams, leaving 22cm in centre open. Pick up 166 sts between markers on side seams and hang on needles, wrong side facing. Set RC 000. Decrease 1 st at each side on every 4th row 33 times. AT THE SAME TIME, knit pattern as follows: 46 rows lace pattern as given above. Turn work and re-hang. Knit 46 rows. Turn work and re-hang. Knit 46 rows. RC 138. Reduce sts to 68 and knit 1 row st st. Set RC 000 and knit 30 rows 2/2 rib. Cast off.

**Finishing:** Close side and sleeve seams.

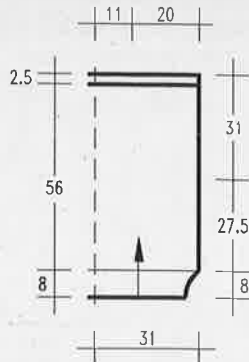

1/2 front and back

## CHANGING COLOURS

Front Row

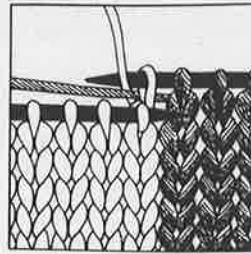

Back Row

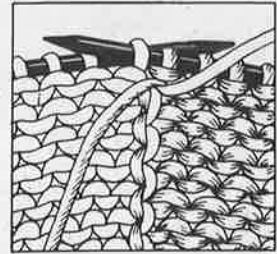

Carry the yarn across to the back of the work.

Chart (front and back)

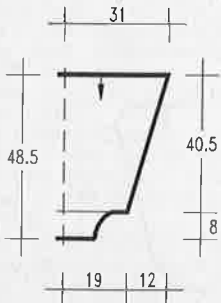
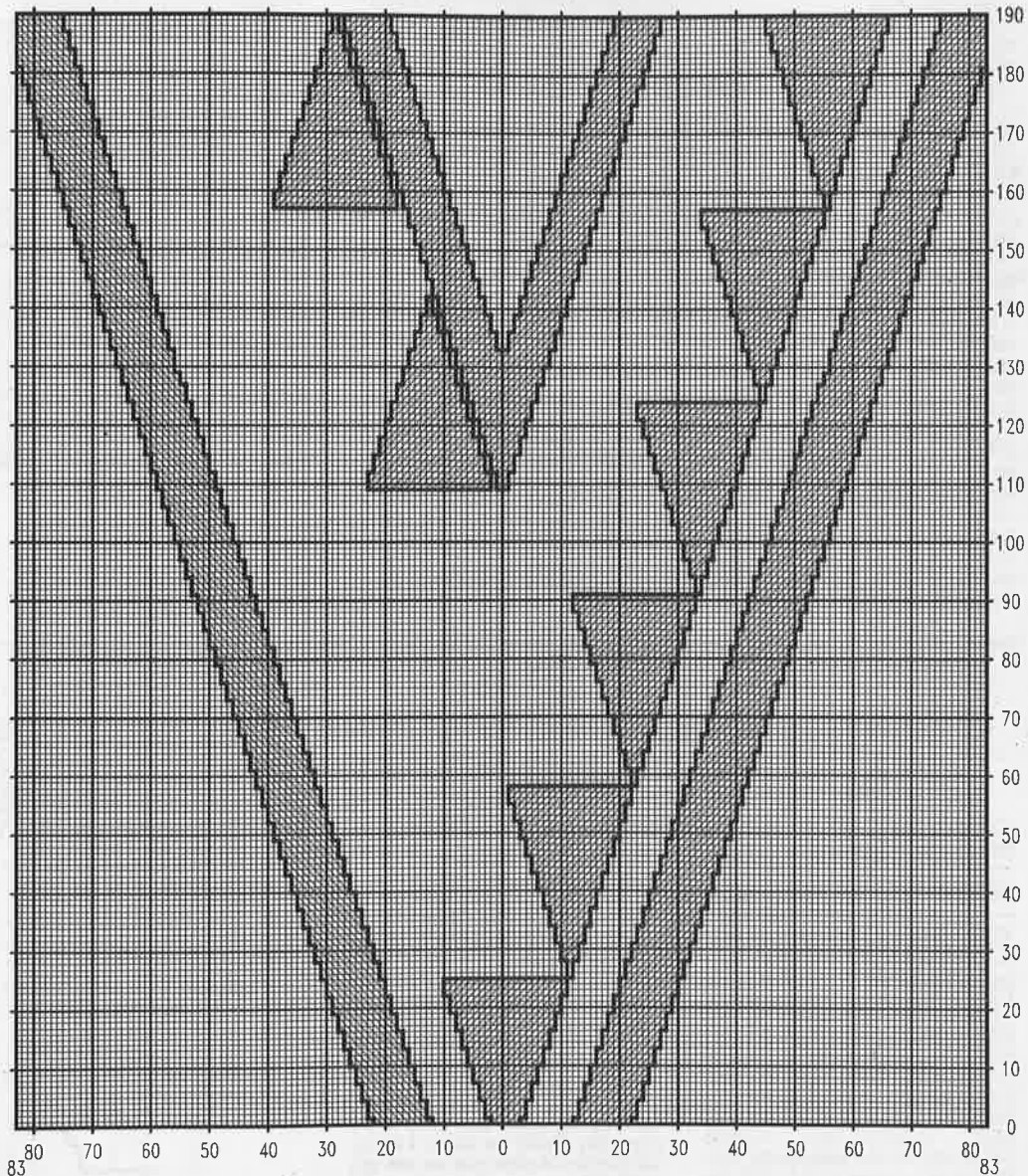

1/2 sleeve

Use yarn of similar meterage when substituting yarns!

# MODEL 4

## WHITE SWEATER WITH FLOWERS

**Size:** 12/14 (16/18). Instructions for the larger size in brackets. One figure only applies to both sizes.

**Machines:** Suitable for standard gauge machines with ribber and intarsia carriage. We used a Knitmaster 580.

**Material:** WOLL SERVICE "Glamour" (55% cotton, 45% viscose, 140m/150g) approx. **500(550) g white.** AUSTERMANN "Angora Wolle" (70% Angora, 30% wool, 125m/25g) approx. **100(125)g white.**

You will also need 75-80 small white flowers, 160-200 long and 180-200 small white beads.

The yarn is available by mail order from WOLLSTUDIO Jutta Hinrichs, Wormser Str. 5, 6550 Bad Kreuznach, Germany. Send Eurocheque for DM 169.00 (DM 177.60) incl. postage.

**Tension:** 30 sts and 36 rows = 10cm. TD approx. 9.

**Ribs:** 1/1 rib at TD approx. 3-4.

**Intarsia:** Knitted from chart, reversing pattern for left side.

**Arrows** on diagrams denote direction of knitting.

**Back:** Cast on with Glamour 160(172) sts and knit 60 rows rib. Transfer all sts to MB and set RC 000. Knit in Glamour and st st, increasing 1 st at each side on every 18th row 5 times = 170(182) sts. AT THE SAME TIME, start the intarsia at RC 60. After RC 120, continue in Angora st st. At RC 100, shape armholes by casting off at each side on alt. rows 4 sts once, 3 sts once, 2 sts 4(5) times and 1 st 12(13) times. Decrease 1 st at each side on every 4th row 6 times = 104(110) sts. Knit straight to RC 182 and shape back neck with HP. Push to HP the centre 22 sts and all sts at side opposite to car-

riage. Knit each side separately. At neck edge push to HP on alt. rows 7 sts 3 times. Cast off rem. 20(23) sts at RC 190. Knit other side. Knit 1 row st st over needles in HP. Transfer sts for rib and knit 25 rows for neckband. Cast off.

**Front:** Cast on and knit as for back to RC 164. Shape neck. Push to HP the centre 20 sts and all sts at side opposite to carriage. At neck edge push to HP on alt. rows 4 sts twice, 3 sts once, 2 sts 3 times and 1 st 5 times. Cast off shoulder sts as on back. Knit neckband as on back.

**Sleeves:** Cast on in Glamour 84 sts and knit 40 rows rib. Transfer all sts to MB and set RC 000. Continue in st st to RC 80, increasing as follows: \* 1 st at each side on every 2nd row twice and on the foll. 4th row once. Repeat from \* till there are 160 sts. At RC 80, start intarsia in the centre. At RC 110, shape top. Cast off at each side on alt. rows 4 sts once, 3 sts once, 2 sts once and 1 st 10 times. Decrease 1 st at each side on every 8th row 6 times = 110 sts at RC 184. Cast off at each side on alt. rows 2 sts 3 times, 3 sts 3 times, 4 sts twice and 5 sts once. Cast off rem. sts at RC 203.

**Finishing:** Sew on flowers at random with one bead in centre. SEW on two long beads together with one round bead in between. Close shoulder and neckband seams. Fold band in half to inside and slipstitch in position. Close side and sleeve seams. Set in sleeves, pleating the top to fit.

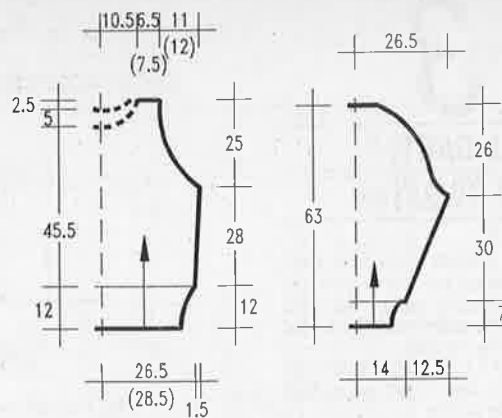

1/2 front and back

1/2 sleeve

### Chart

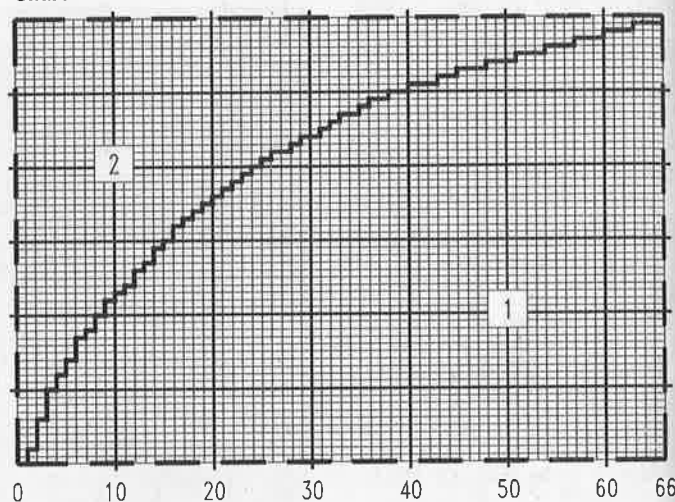

### Key:

- 1 = Glamour
- 2 = Angora
- 1 square = 1 st and 1 R

# MODEL 5

## WHITE INTARSIA SWEATER WITH FLOWERS

**Size:** 12 - 16.

**Machines:** Suitable for standard gauge machines with ribber and intarsia carriage. We used a Knitmaster 580.

**Material:** WOLL SERVICE "Glamour" (55% cotton, 45% viscose, 145m/50g) approx. **550g white.** AUSTERMANN "Angora Wolle" (70% Angora, 30% wool, 125m/25g) approx. **100g white.**

Available by mailorder from WOLLSTUDIO Jutta Hinrichs, Wormser Str. 5, 6550 Bad Kreuznach, Germany. Send

Eurocheque for DM 174.50 to incl. postage.

You will also need 5m bead strip white, 1 large white lace flower, 4 small white lace flowers, 10 small white velvet flowers, 100 medium white beads.

**Tension:** 30 sts and 36 rows = 10cm at TD approx. 9.

**Ribs:** 1/1 rib at TD approx. 3\*\*-4.

**Intarsia:** Knitted from charts 1 and 2. Chart 2 is reversed around left edge.

**Arrows** on diagrams denote direction of knitting.

**Front:** Cast on with Glamour 162 sts and knit 60 rows rib. Transfer all sts to MB and set RC 000. Continue in st st, increasing 1 st at each side on the 18th and every foll. 18th row 5 times = 172. AT THE SAME TIME, when RC shows 42, start the intarsia from chart 1. The chart only shows the centre 140 sts, use Glamour at either side on rem. sts. At RC 100, shape armholes. Cast off 2 sts at each side on every 2nd row 8 times = 140 sts. Knit straight to RC 166 and shape neck. Set carriage for HP and push to HP the centre 24 sts and all sts at side opposite to carriage.

On first side, push to HP at neck edge on alt. rows 4 sts once, 3 sts once, 2 sts 4 times and 1 st 5 times. Cast off rem. 38 sts at RC 190. Repeat for other side. For the neckband, knit 1 row st st over needles in HP. Transfer sts for 1/1 rib and knit 24 rows. Cast off.

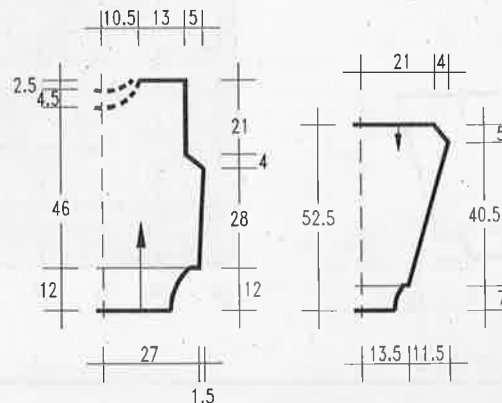

1/2 front and back

1/2 sleeve

rows 1 st 6 times and 2 sts 3 times: 152 sts at RC 18. Set RC 000 and knit in st st, decreasing 1 st at each side on every 4th row 35 times = 82 sts at RC 146. Reduce sts to 72 and knit 1 row. Transfer sts for rib and knit 40 rows 1/1 rib. Cast off.

**Right sleeve:** Knit as for left sleeve, but start with intarsia pattern from chart 2. Continue in Glamour.

**Finishing:** Close shoulder and neckband seams. Fold neckband in half to inside and slipstitch in position. Set in sleeves. Sew the bead strip along the edge of the intarsia. Sew on flowers and beads at random. Close remaining seams.

**Key:**

- 1 = Glamour
- 2 = Angora
- 1 square = 1 st and 1 R

**Chart 1 (front or back) Model 5**

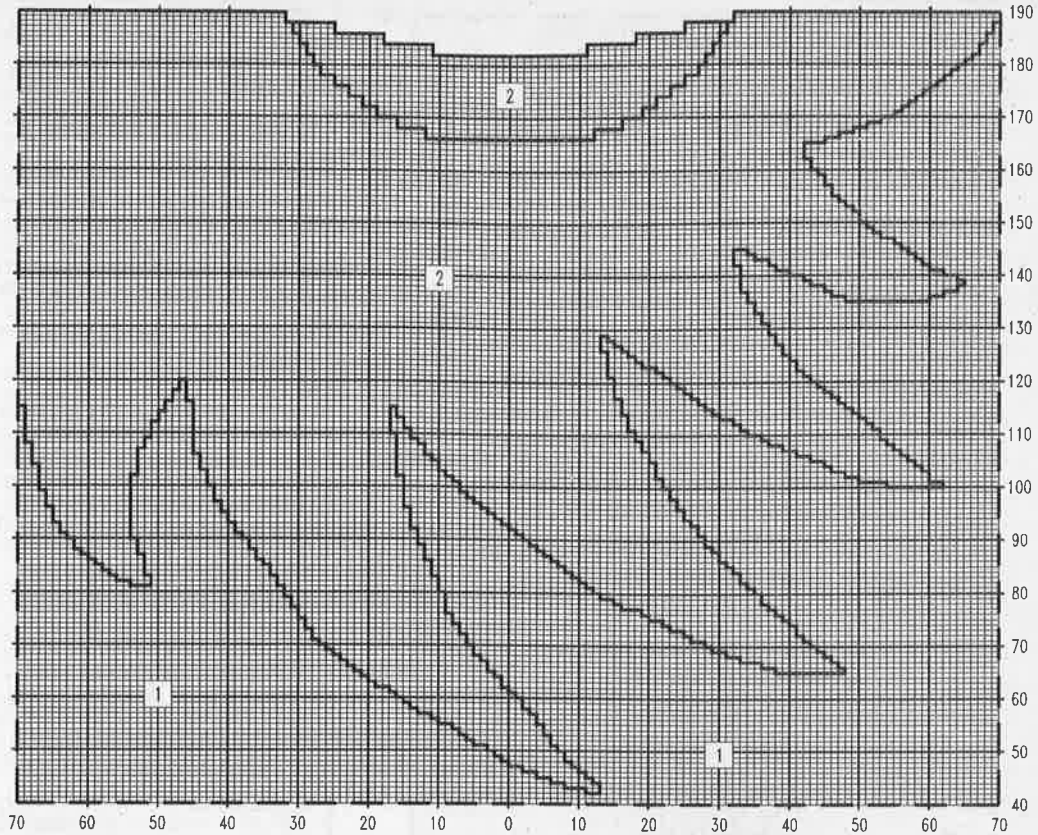

# MODEL 6

## RED INTARSIA SWEATER

**Size:** 12/14 (16/18). Instructions for the larger size are in brackets. One figure only applies to both sizes.

**Machines:** Suitable for standard gauge machines with ribber and intarsia carriage. We used a Brother KH 930.

**Material:** HAMBURGER WOLFFABRIK Cotton (80% cotton, 20% polyacryl, 150m/50g) approx. 600(650)g red.

Small amounts of silk or viscose in red and black. Cotton in black and white. Gold Lurex.

Available as a complete kit from STRICKSTUDIO HAMBURG, Barenfelder Str.168, 2000 Hamburg 50, Germany. Send Eurocheque for DM 160.00 incl. postage.

**Tension:** 27-28 sts and 34 rows = 10cm at TD 9\*\*

**Ribs:** 2/2 rib at TD approx. 3.

**Intarsia:** Knitted from the chart, reversing the pattern from 0 to the left.

**Arrows** on diagrams denote direction of knitting.

**Front:** Cast on in mainyarn 160(172) sts and knit 52 rows 2/2 rib. Transfer all sts to MB and set RC 000. Continue in st st to RC 10. Start intarsia and work till RC shows 110. Shape armholes. Set multi-transfer tool with 6 prongs out. \* At each side move 6 sts in by 3. Knit 6 rows. Repeat from \* 6(7) times = 21(24) sts decreased at each side. Knit straight to RC 166 and shape neck.

Set carriage for HP. Push to HP the centre 24 sts and all sts at side opposite to carriage. On first side push to HP on alt. rows 1 st 12 times. Cast off rem. 35(38) sts at RC 210. Repeat for other side. For the neckband, pick up 20 sts along the straight edges at side of neck = 88 sts. Knit 1 row st st. Transfer sts for rib and knit 12 rows. Cast off.

**Back:** Cast on and knit as for front, but knit only the striped triangle in intarsia. Knit armhole shaping as on front. Knit to RC 202 and shape neck. Push to HP the centre 42 sts and all sts at side opposite to carriage. Knit each side separately, pushing to HP at neck edge on alt. rows 1 st 3 times. Knit neckband as for front without picking up additional sts.

**Sleeves:** Cast on 80(82) sts in mainyarn and knit 60 rows 2/2 rib. Transfer all sts to MB and set RC 000. Continue in st st, increasing 1 st at each side on every 4th row 24(26) times = 128(134) sts. When RC shows 102(106) shape sleeve top as given for front with multi-transfer tool. Decrease 3 sts at each side on every 6th row 8 times; on every 4th row 6 times and on alt. rows 5(6) times. Cast off rem. 14 sts at RC 180(186).

**Finishing:** Close all seams and set in sleeves.

cont. next page

**Chart 2 (right sleeve) Model 5**

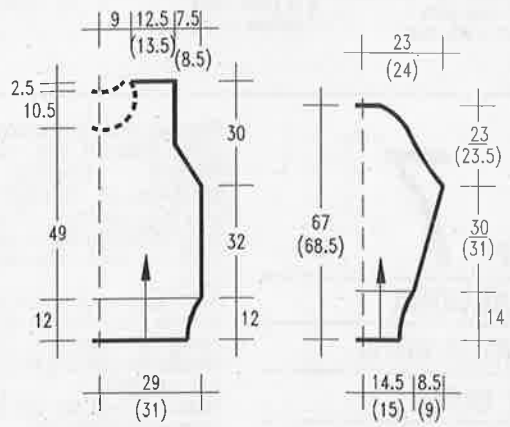
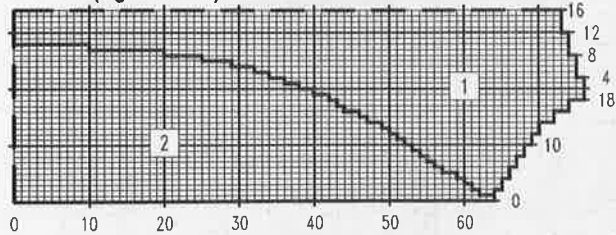

1/2 front and back

1/2 sleeve

Chart for Model 6

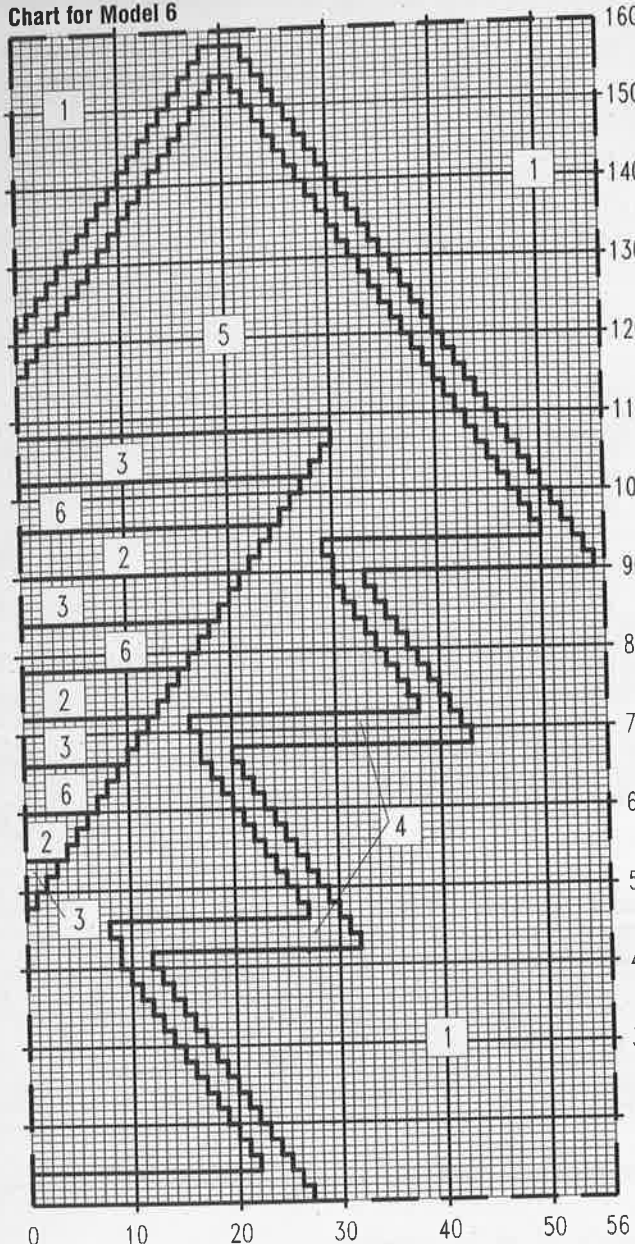

**Key:**  
 1 = red cotton (main colour)  
 2 = red shiny yarn  
 3 = black shiny yarn  
 4 = black cotton  
 5 = white cotton  
 6 = gold Lurex  
 1 square = 1 st and 1 R

in WP. Knit 2 rows. Repeat transfers, using the alternate sts.

**Arrows** on diagrams denote direction of knitting.

**Back:** Cast on in Constant 144(154) sts and knit 50 rows rib. Transfer all sts to MB and continue in st st with Angora. At RC 76, shape armholes. Cast off at each side on alt. rows 5 sts once, 4 sts once, 3 sts once, 2 sts twice (3 times) and 1 st once = sts. Knit straight to RC 156 and shape neck. Cast off centre 34 and knit each side separately. At neck edge, cast off on alt. rows 4 sts once, 3 sts once, 2 sts once and 1 st once. Cast off rem. 28(31) sts at RC 166. Repeat for other side, reversing shaping.

**Front:** Cast on and knit as for back to RC 26. Start intarsia and lacy pattern as in chart, reversing the pattern for the left side. Knit to RC 136 and shape neck. Cast off the centre 18 sts and knit each side separately. At neck edge cast off on alt. rows 5 sts once, 3 sts once, 2 sts twice and 1 st 6 times. Cast off rem. sts at RC 166. Repeat for other side.

**Sleeves:** Cast on in Constant 74(80) sts and knit 62 rows 2/2 rib. Change to Angora and set RC 000. Increase 1 st at each side on every 8th row 4 times and on every 6th row 12 times = 106(112) sts. At RC 108, shape top. Cast off at each side on alt. rows 5 sts once, 2 sts 3 times, 1 st 11 times, 2 sts 4 times, 3 sts once and 4 sts twice. Cast off rem. 18(24) sts at RC 156.

**Neckband:** Cast on in Constant 140 sts and knit 16 rows 2/2 rib. Release on waste yarn or cast off loosely.

**Finishing:** Close shoulder seams. Sew in neckband either backstitching through open loops or sewing in cast-off edge. Close rem. seams and set in sleeves.

Chart for Model 7

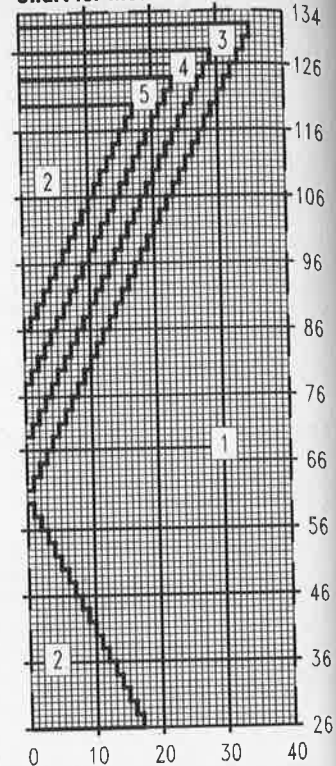

**Key:**  
 1 = Angora red st st  
 2 = Constant red lace pattern  
 3 = Lurex st st  
 4 = Constant black st st  
 5 = Constant white st st  
 1 square = 1 st and 1 row. 1

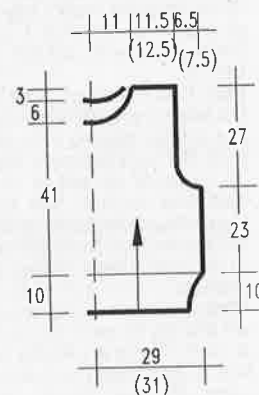

1/2 front and back

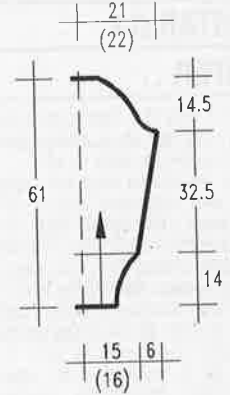

1/2 sleeve

# 7

## MODEL

### RED ANGORA

### SWEATER WITH

### LACY INSERT

**Size:** 12/14 (16/18). Instructions for the larger size are in brackets. One figure only applies to both sizes.

**Machines:** Suitable for standard gauge machines with ribber and intarsia carriage. We used a Brother KH 940.

**Material:** SCHACHENMAYR "Angora" (70% Angora, 20% wool, 10% polyamid 210m/50g) approx. 350(375)g red. "Constant" (50% cotton, 50% polyacryl, 210m/50g) approx. 150(200)g red. Small amount in white and black. Small amount gold Lurex.

Available as a complete kit from Christl Haegele, Burg-Windeck-Str. 4b, 7580 Bühl/Baden, Germany. Send Eurocheque for DM 318.00(DM 342.00) incl. postage.

**Tension:** 24-25 sts and 33 rows = 10cm at TD approx. 10.

**Ribs:** 2/2 rib at TD 2\*\* with garter carriage or ribber.

**Intarsia:** Knitted from the chart, crossing the yarns at the back to avoid holes. The lacy insert is knitted by transferring alt. sts to the left, leaving empty N

### Buttonholes

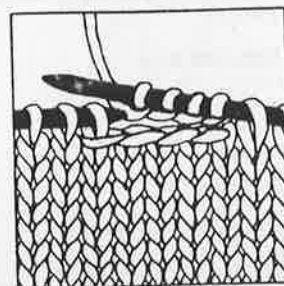

There are 2 possibilities: a) c off the required shown here - or b) you c off st without knitting them first and c o the required st straight away.

# 8

## MODEL

### BLUE TEXTURED

#### SWEATER

**Size:** 12/14 (16/18). The instructions for the larger size are in brackets. One figure only applies to all sizes.

**Machines:** Suitable for standard gauge machines with ribber. Punchcard machines must adapt the pattern.

**Material:** SCHACHENMAYR "Monsun" (80% polyacryl, 20% viscose, 125m/50g) approx. 900(1000)g in cornflower blue. Alternately "Nomotta Extra" (100% superwash wool, 125m/50g) in blue.

The yarn is available as a kit from Christie Haegele, Burg-Windeck-str. 4b, 7580 Bühl/Baden, Germany. Send Eurocheque for DM 91.50 (DM 99.00) incl. postage.

**Tension:** 28 sts and 36 rows = 10cm at TD approx. 10\*\*.

**Ribs:** 2/2 rib at TD approx. 5-6.

**Pattern:** Mark mylar sheet or use Stitch World pattern No.1. Adapt the pattern for punchcard machines. Knit on a Fairisle setting, using the same yarn in both feeders. Knit 8 rows. Liff the 8 threads with the latchtool and place them on the centre needle of the next selected needles. Pull the needle to D-position and continue to knit.

**Arrows** on diagrams denote direction of knitting.

**Back:** Cast on with waste yarn over needles left 77 to right 76 (left 84 to right 83) = 153(167) sts. Knit several rows. Change to mainyarn and set RC 000. Knit in pattern as given to RC 120. Shape armholes. With multi-transfer tool set with 6 prongs out, decrease 3 sts at each side by moving 6 sts in by

3. Knit 4 rows. Repeat the decreases 6(7) times = 21(24) sts decr. each side. Knit straight to RC 192. Shape neck. Cast off the centre 25(27) sts. and knit each side separately. At neck edge cast off on alt. rows 6 sts once, 4 sts once and 3 sts once. Cast off rem. 30(33) sts at RC 200.

**Front:** Cast on and knit as for back to RC 168. Shape neck. Cast off the centre 35(37) sts and knit each side separately. At neck edge cast off on alt. rows 2 sts 3 times and 1 st twice. Cast off rem. 30(33) sts at RC 200.

**Sleeves:** Cast on with wasteyarn over needles 41 left to 40 right (44 left to 43 right) and knit several rows. Change to main yarn and set RC 000. Continue in pattern, incr. 1 st at each side on every 6th row 17 times = 115(121) sts. At RC 104, shape top. Decrease as given for back at each side 3 sts on every 4th row 7(8) times altogether = 73 sts. Knit straight to RC 184 and cast off.

**Welts:** Push 140(148) needles to WP. Pick up sts from lower edge of back or front and hang on needles, decreasing evenly across the row. Knit 1 row st st. Transfer sts for rib and knit 30 rows. Cast off.

**Cuffs:** Push 60(64) needles to WP and pick up sts from lower edge of sleeve. Hang on needles, decreasing evenly across the row. Knit 1 row st st. Transfer for rib. Knit 40 rows and cast off.

**Neckband:** Cast on 144(150) sts in 2/2 rib and knit 15 rows. Cast off loosely.

**Finishing:** Close shoulder seams. Sew neckband into neckline. Close side and sleeve seams. Set in sleeves, gathering top to fit.

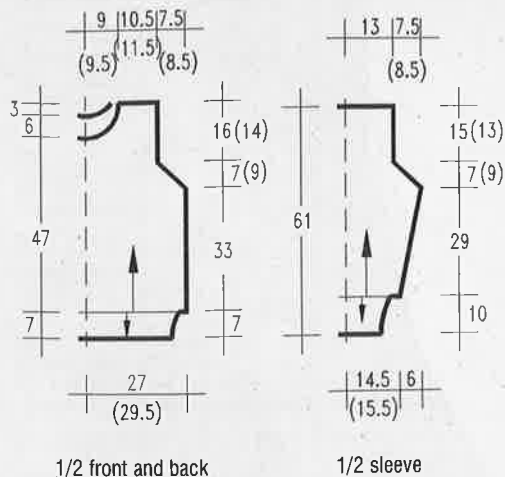

Pattern 1

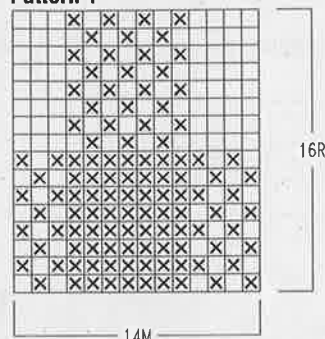

# 9

## MODEL

### BLACK AND WHITE

#### SWEATER

**Size:** 16 - 20.

**Machines:** Suitable for standard gauge machines with ribber and intarsia carriage. We used a Brother KH 930.

**Material:** WSM "Ella" (54% cotton, 46% viscose, 140m/50g) approx. 550g white and 100g black. "Angora Nova" (75% Angora, 25% lambswool, 90m/20g) approx. 40g each black and white.

The yarn is available as a kit from Christie Haegele, Burg-Windeck-Str. 4b, 7580 Bühl/Baden, Germany. Send Eurocheque for DM 149.00 incl. postage.

**Tension:** 28 sts and 37 rows = 10cm at TD 8.

**Ribs:** 1/1 rib at TD approx. 2.

**Intarsia:** Knitted from the chart. Take care to cross yarns when changing colours to avoid holes.

**Arrows** on diagrams denote direction of knitting.

**Front:** With Ella white, cast on 148 sts and knit 50 rows rib. Transfer all sts to MB, incr. sts to 168. Set RC 000. Now work from chart for intarsia, reading the armhole shaping from the chart. At RC 192, shape neck, using HP and reading the lower neckline from the chart. At RC 212, cast off rem. 18 sts for the shoulder. Return sts from HP to WP and knit 1 row st st in Ella white. Transfer for rib and knit 12 rows in 1/1 rib. Cast off.

**Back:** Cast on and knit as for front, but reversing the intarsia design. Shape armholes and neck as shown on chart. Knit neckband as given for front.

**Sleeves:** Cast on in Ella white 70 sts and knit 50 rows 1/1 rib. Knit the last 2 rows on looser tensions. Transfer all sts to MB, increasing to 90 sts evenly across the row. Continue in Ella white and st st. Increase 1 st at each side on every 3rd row 35 times = 160 sts. At RC 106, shape top. Cast off at each side on alt. rows 4 sts once, 3 sts once, 2 sts once and 1 st 10 times.

Decr. 1 st at each side on every 8th row 6 times = 110 sts at RC 180. Decrease at each side on alt. rows 2 sts 3 times, 3 sts 3 times, 4 sts twice and 5 sts once. Cast off rem. sts.

**Finishing:** Close all seams and set in sleeves.

cont. next page

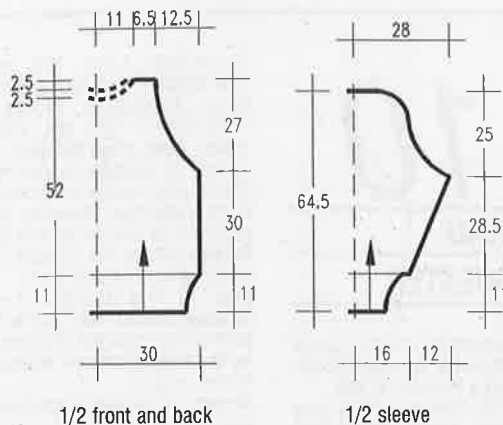

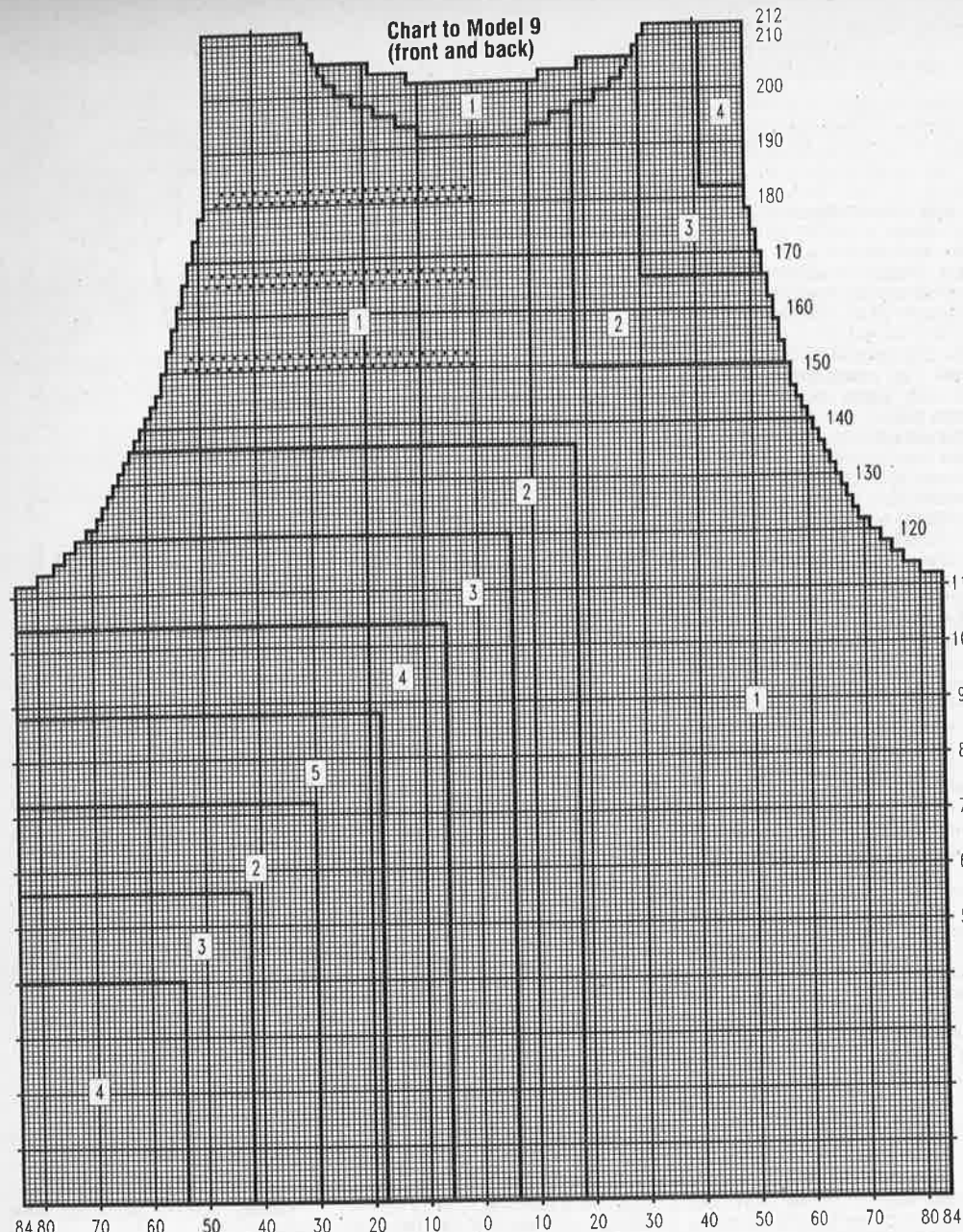

**Key:**  
 1 = Ella white  
 2 = Angora black  
 3 = Ella black  
 4 = Angora white  
 5 = Ella white  
 • = transfer st to right. Empty N in WP.  
 1 square = 1 st and 1 R

shown for the lower neckline. At RC 222, cast off rem. 18 sts for the shoulders.

**Back:** Work as for front, using the higher neckline.

**Sleeves:** Cast on with waste yarn 82 sts and knit several rows. Set RC 000 and continue in st st with Silvana, incr. st at each side on every 3rd row 39 times = 160 sts. When RC shows 120, work from chart 2 for intarsia and shapings. Cast off rem. 40 sts at RC 240.

**Welts:** Cast on 140 sts in 1/1 rib and knit 40 rows. Hang the sts from lower edge of back or front on same needles, decreasing evenly across the row. Knit 1 row and cast off.

**Cuffs:** Cast on 62 sts in 1/1 rib and knit 40 rows. Re-hang sts from lower edge of sleeves on same needles, decreasing evenly across the row. Knit 1 row and cast off.

**Finishing:** Close one shoulder seam. With wrong side out, pick up 120 - 125 sts from neckline and hang on needles. With Angora Nova black knit 16 rows st st and cast off. Close rem. seams. Set in sleeves, gathering the top to fit.

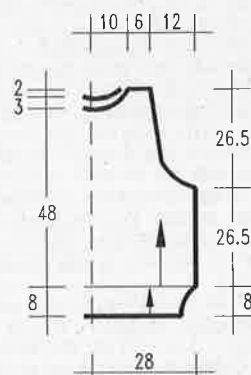

1/2 front and back

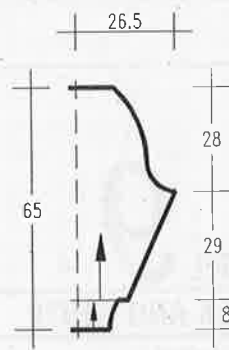

1/2 sleeve

# MODEL 10

## BLACK AND GOLD SWEATER

Size: 12 - 16.

**Machines:** Suitable for standard gauge machines with ribber and intarsia carriage. We used a Brother KH 940.

**Material:** WSM "Silvana" (100% pure silk, 150m/50g) approx. 450g gold. "Angora Nova" (75% Angora, 25% lambswool, 95m/20g) approx. 60g black and 40g gold. Accent yarn

"Deco" (45% Lurex, 18% polyamid, 37% acetate, 57m/25g) approx. 100g black. STAHLSCHE WOLLE "Thai" (70% viscose, 30% silk, 135m/50g) approx. 100g green fleckend.

The yarn is available as a kit from E&S Strickstudio, Zinnigbergasse 9, 8015 Markt Schwaben, Germany. Send Eurocheque for DM 294.65 incl. postage.

**Tension:** 30 sts and 42 rows = 10cm knitted with Silvana at TD 8.

**Ribs:** 1/1 rib at TD approx. 3-4.

**Intarsia:** Knitted from charts 1 and 2. Both charts show the shapings as well as the designs and are reversed from the left edge.

**Arrows on diagram** denote direction of knitting.

**Front:** Cast on with waste yarn 170 sts and knit several rows. Set RC 000 and work from chart 1. Use the shapings

### The crab-stitch

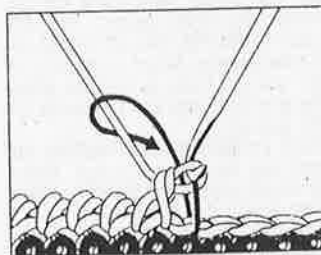

**For attractive edges on knitted and crocheted garments:**

With crochet hook pick up lower st in direction indicated by arrow and draw loop through as shown. Yarn over hook and as draw through both loops.





Chart 1 (1/2 front and back) Model 10

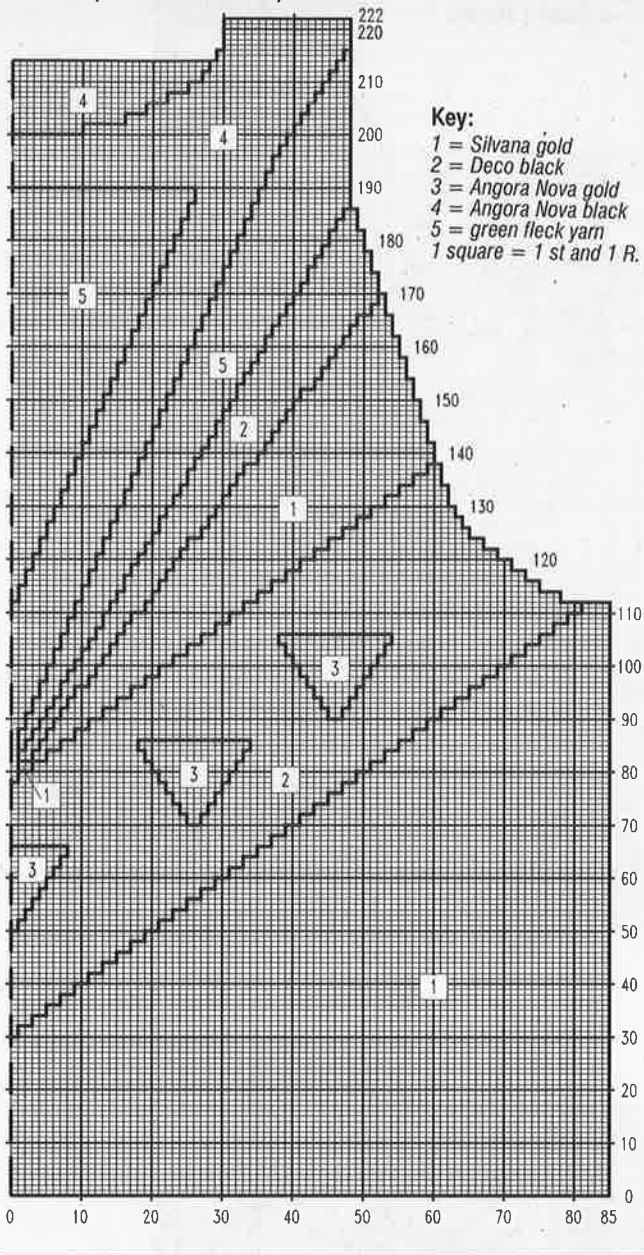
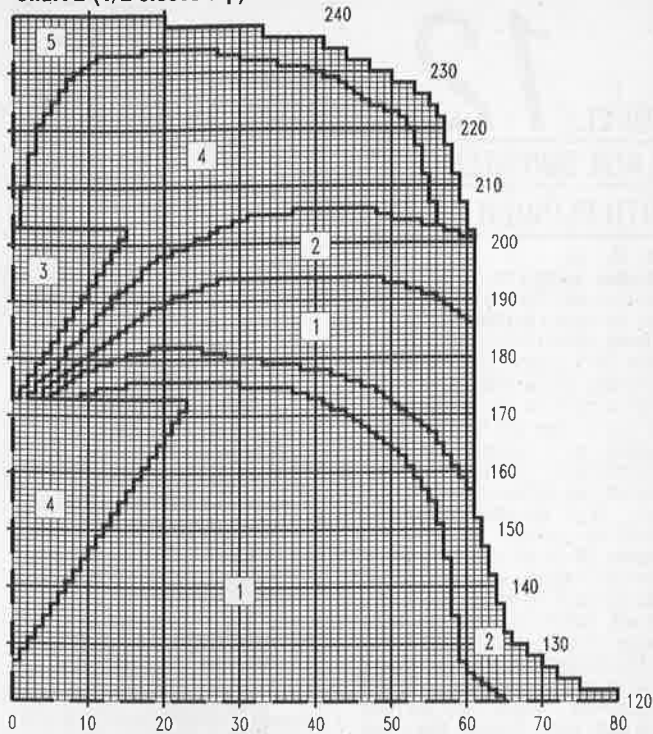

Chart 2 (1/2 sleeve top) Model 10



off the rem. 36 sts at **RC 174(180)[186]**.

**Front:** Cast on and knit as for back to **RC 142(148)[154]**. Divide work in centre for V-neck and knit each side separately. Working raglan shaping as before, decrease at inner edge 1 st on alt. rows 15 times. Cast off the rem. 3 sts at **RC 174(180)[184]**.

**Sleeves:** Cast on with wasteyarn 64(68)[72] sts and knit several rows. Set **RC 000** and knit with main yarn in st st. Increase 1 st at each side on every 10th row 11 times (on every 8th row 14 times) [on every 7th row 15 times and every 5th row twice] = 86(96)[106] sts. When **RC shows 118**, shape raglan as described on back. Cast off rem. 8 sts at **RC 190(196)[202]**.

**Collar:** Cast on in rib 114 sts. On every 2nd row, increase 1 st at each side 14 times = 142sts. At **RC 30**, push empty needles on both beds to WP. Set car-

riages for circular knitting and knit 8 rows - 4 on each bed. Knit several rows waste yarn and release from machine. **Finishing:** Close raglan seams with mattress stitch from right side. Join short sides of collar. Sew on collar from right side by backstitching through open loops and repeat on inside. Remove waste yarn. Close rem. seams.

# MODEL 11

## MAIZE YELLOW

### RAGLAN SWEATER

**Size:** 10/12 (14/16) [18/20]. The instructions for the larger sizes are in brackets. One figure only applies to all sizes.

**Machines:** We used a Singer standard gauge double bed machine. Could also be knitted on other chunky machines.

**Material:** WSM "Lhasa" (50% lambswool, 30% Angora, 10% cashmere, 90m/20g) approx. 340(360)[380]g maize yellow. Alternately SCHACHEN-

MAYR JAEGER "Angora" (70% Angora, 20% lambswool, 10% polyamid, 90m/20g) amounts as above.

The alternative yarn is available as a kit from Christle Haegele, Burg-Windeck-Str. 4b, 7580 Bühl/Baden, Germany. Send Eurocheque for DM 190.00 (DM 200.00) [DM 210.00] incl. postage.

**Tension:** 21 sts and 29-30 rows = 10cm TD approx. 11.

**Ribs:** 2/2 rib at TD approx. 5.

**Arrows** on diagram denote direction of knitting.

**Back:** Cast on 114(124)[134] sts in 2/2 rib and knit 25 rows rib. Set **RC 000**. Transfer all sts to MB and knit in st st. At **RC 102**, cast off at each side 4(6)[8] sts. Fully fashioned raglan shaping: Take the 4th st from edge on single transfer tool. Move the 3 outer sts in by one. Replace 4th st on 3rd needle. Repeat for other side. Repeat the decreases 34(37)[40] times. Cast

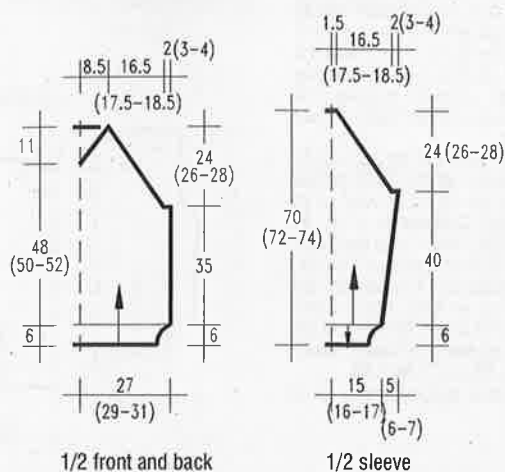

# MODEL 12

## BLACK SWEATER WITH FLOWER YOKE

Size: 12 - 16.

**Machines:** Suitable for standard gauge machines with ribber and intarsia carriage. We used a Brother KH 930.

**Material:** HAMBURGER WOLLFABRIK Cotton (80% cotton, 20% polyacryl, 150m/50g) approx. 500g black.

Small amounts of silk or viscose in blue and lt. blue and brown Angora. Available as a complete kit from STRICKSTUDIO HAMBURG, Barenfelder Str. 16B, 2000 Hamburg 50, Germany. Send Eurocheque for DM 160.00 incl. postage.

**Tension:** 28-29 sts and 35 rows = 10cm at TD approx. 9\*.

**Ribs:** 2/2 rib at TD approx. 3.

**Flat rib:** Ribber in H-position. Push needles 72-0-72 on both beds to WP. On Brother machines put slide lever on 1. Knit zig-zag row and hang comb and weights. Knit 2 circular rows. Set TD at 3 on both beds. Transfer every 2nd stitch on RB to MB. Knit rib at this setting.

**Intarsia:** Knitted from charts 1 and 2. Cross yarns on back when changing colours to avoid holes. Smaller areas may be swiss-darned.

**Arrows** on diagrams denote direction of knitting.

**Front:** Push 144 N on both beds to WP and knit as given for flat rib for 24 rows. Transfer all sts to MB and set RC 000. Knit from chart 1, reading the increases at the sides from the chart. At RC 106, shape armholes. Set multi-transfer tool with 6 prongs out. Move 6 sts at each edge in by 3, push empty N to NWP. Knit 5 rows. Repeat the decreases at each side 6 times = 21 sts decr. each side. Knit in intarsia to RC 164 and shape neck as shown on the chart. Use HP shaping. Cast off the rem. 33 sts on shoulder at RC 200. After knitting the 2nd side, return N from HP to WP. Pick up 22 sts along straight edge of neckline at each side = 92 sts in WP. Knit 1 row st st. Transfer for 2/2 rib and knit 15 rows. Cast off.

**Back:** Cast on and knit rib as for front. Knit in black st st, incr. at each side as on front. Shape armholes as on front. At RC 150, change to intarsia and knit from chart 2, reading the neck shaping from the chart, using HP shaping. Knit neckband as given for front without additional sts.

**Sleeves:** Cast on in 2/2 sts and knit 40 rows rib. Transfer all sts to MB and set RC 000. Knit one intarsia flower as on front in centre. Continue in st st. AT THE SAME TIME, incr. 1 st at each side on every 4th row 25 times = 130 sts. At RC 106, shape top, \* Decrease 3 sts at each side as on front. Knit 6 rows. Repeat from \* 6 times. Decrease 3 sts at each side on every 4th row 9 times. Cast off rem, 34 sts at RC 180.

**Finishing:** Close all seams and set in sleeves.

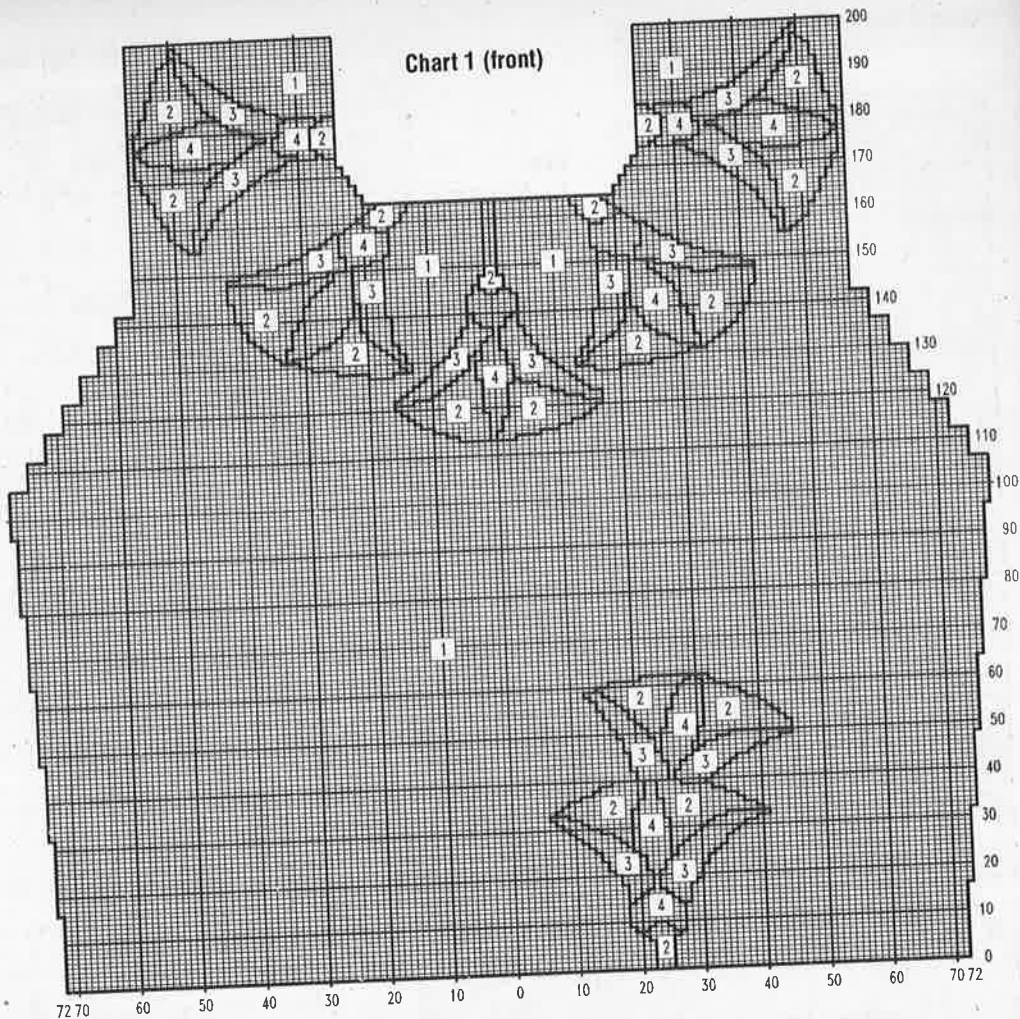
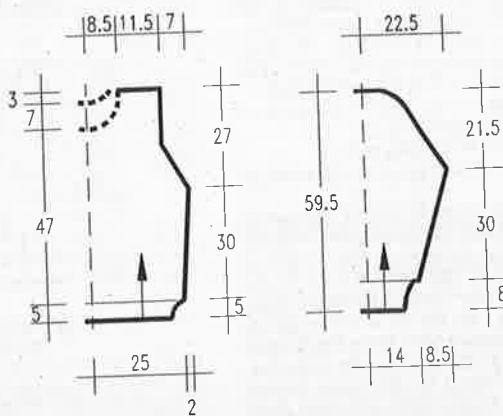
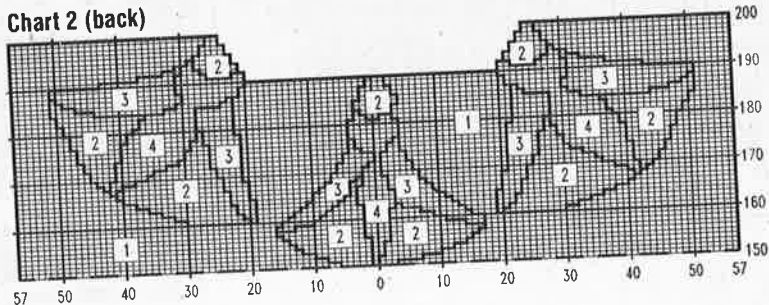

Chart 2 (back)



1/2 front and back

1/2 sleeve

**Key:**

- 1 = black (main colour)
- 2 = Angora brown
- 3 = lt. blue shiny yarn
- 4 = blue shiny yarn
- 1 square = 1 st and 1 R

# MODEL 13

## BLACK JACKET WITH FLOWER YOKE

Size: 12 - 16.

**Machines:** Suitable for standard gauge machines with ribber and intarsia carriage. We used a Brother KH 930.

**Material:** HAMBURGER WOLLFABRIK Cotton (80% cotton, 20% polyacryl, 150m/50g) approx. **550g black.** Small amounts of beige and lt. beige silk or viscose. Brown Angora.

Available as a complete kit from STRICKSTUDIO HAMBURG, Barenfelder Str. 168, 2000 Hamburg 50, Germany. Send Eurocheque for 170.00 incl. postage.

You will also need 7 buttons and a multi-transfer tool.

**Tension:** 28-29 sts and 35 rows = 10cm at TD approx. 9\*.

**Ribs:** 2/2 rib at TD 3.

**Flat ribs:** Set RB to H-position. Push required number of needles on both beds to WP. Knit zig-zag row. Hang comb and weights. Knit 2 circular rows. Set TD 3 and on Brother machines set slide lever to I. Transfer alt. sts. from RB to MB. Knit on this setting.

**Intarsia:** Knitted from charts 1 and 2 as given for model 12, but changing colours as follows: 1 = black, 2 = brown, 3 = lt. beige, 4 = beige.

**Arrows** on diagrams denote direction of knitting.

**Back:** Cast on 144 sts on both beds and knit 24 rows flat rib. Transfer all sts

to MB and set RC 000. Work in intarsia from chart 1, reading shapings from the chart. When **RC shows 52**, change to st st and knit to RC 150. Knit the intarsia pattern for the top from chart 2. AT THE SAME TIME, when **RC shows 106**, shape armhole. Set multi-transfer tool with 6 prongs out. \* Move 6 sts at each end in by 3, putting empty N in NWP. Knit 6 rows. Repeat from \* 6 times more = 21 sts decr. each side. Shape neck according to the chart, using HP shaping. At **RC 200**, cast off rem. sts for the shoulder. After knitting 2nd side, return N from HP to WP. Knit 1 row st st at TD 9. Knit 5 rows st st at TD 5. Pick up loops from first row of st st and hang on same needles. Pull needles to D-position and set TD. Knit 1 row st st. This forms one tuck or pleat. Knit 4 more pleats and cast off.

**Right front:** Cast on 72 sts on each bed. Knit 24 rows Flat Rib as described for back. Transfer all sts to MB. Knit in st st, shaping at right edge and shaping armholes as on back. At **RC 113**, change to intarsia from chart 1. Knit the 2 flowers at right only, omitting the centre flower. The neckline is shaped from RC 164, using HP shaping. At left edge, push 20 sts to HP and follow chart for other decreases. The pleats for the neck band are knitted over 50 sts, as on back, picking up an additional 26 sts from the straight edge of the neck.

**Left front:** Knit as for right front, reversing the pattern and shapings.

**Pockets:** E-wrap cast on 36 sts. Knit 40 rows black st st. Knit 3 pleats as described for neckband. Cast off.

**Sleeves:** Cast on 80 sts in 2/2 rib and knit 40 rows. Transfer all sts to MB. Set RC 000. Knit 1 intarsia flower from chart 1 in centre, increasing at the same time 1 st at each side on every 4th row 25 times = 130 sts. At **RC**

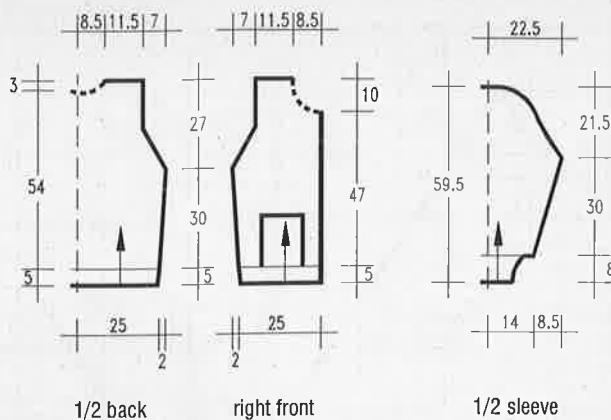

**106**, cast off 3 sts at each side as described for back. Repeat the decreases on every 6th row 6 times and on every 4th row 9 times. Cast off rem. 34 sts at **RC 180**.

**Buttonhole band:** With wrong side facing, pick up 154 sts from right front edge and hang on needles. Set TD 6\*\*. In back and st st knit 28 rows, making 7 buttonholes on the 7th and 21st rows at equal distances. Cast off and slip-stitch to inside.

**Button band:** Knit as above on left front edge, omitting the buttonholes.

**Finishing:** Close all seams. Sew on pockets with mattress stitch in position shown on diagram. Set in sleeves. Sew on buttons.

# MODEL 14

## TURQUOISE SWEATER WITH ANGORA YOKE

Size: 12 - 16.

**Machines:** Suitable for standard gauge machines with ribber and intarsia carriage. We used a Knitmaster 580.

**Material:** WOLL-SERVICE "Glamour" (55% cotton, 45% viscose, 145m/50g) approx. **650g turquoise.** AUSTRMANN "Angora-Wolle" (70% Angora, 30% wool, 125m/25g) approx. **25g white.**

Available as a complete kit from WOLL-STUDIO Jutta Hinrichs, Wormser Str. 5, 6550 Bad Kreuznach, Germany. Send Eurocheque for DM 139.00 incl. postage.

You will also need 110cm white bead strip, 110cm gold braid, 2 large and 1 small lace flowers, 4 small beaded flowers.

**Tension:** 30 sts and 36 rows = 10cm at TD 9.

**Ribs:** 1/1 rib at TD 3\*\* to 4.

**Intarsia:** Knitted from chart to RC 146. After this continue the Angora area in direction of arrows, till no turquoise sts remain.

**Back:** Cast on 162 sts in Glamour and knit 60 rows rib. Transfer all sts to MB and set RC 000. Knit in st st, incr. 1 st at each side on every 18th row 5 times = 172 sts. At **RC 100**, shape armholes. Cast off 2 sts at each side on alt. rows 8 times = 140 sts. Knit straight to **RC 182** and shape neck. Push to HP the centre 22 sts and all sts at side opposite to carriage. At neck edge, push to HP on alt. rows 7 sts 3 times. Cast off rem. 38 sts for shoulders on **RC 190**. Repeat for other side. Return the 64 sts from HP to WP. Knit 1 row st st. Transfer sts for rib and knit 24 rows. Cast off.

**Front:** Cast on and knit as for back to **RC 66**. Work from intarsia chart to **RC 164** and shape neck. Push to HP the centre 24 sts and all sts at side opposite to carriage. At neck edge push to HP on alt. rows 4 sts once, 3 sts once, 2 sts 4 times and 1 st 5 times. Repeat for other side. Return needles from HP

to WP and knit neck band as on back, but using Angora.

**Sleeves:** Knitted from top downwards. E-wrap cast on 128 sts in turquoise. Set RC 000. Increase at each end of every foll. row 1 st 12 times and 2 sts 6 times = 152 sts at **RC 18**. Set RC 000 and knit in st st, decreasing 1 st at each side on every 4th row 35 times = 82 sts. At **RC 146**, re-hang sts on 72

needles. Knit 1 row. Transfer for 1/1 rib and knit 40 rows. Cast off.

**Finishing:** Close shoulder and neckband seams. Fold band in half to inside and sew down. Sew on flowers. Sew the gold braid and bead strip along the intarsia line, approx. 2-3cm apart. Set in sleeves and close rem. seams.

cont. next page

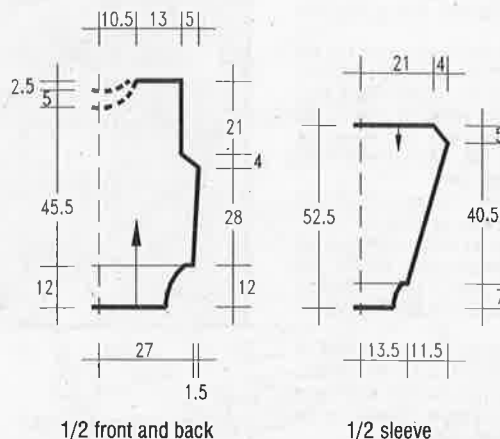

Chart

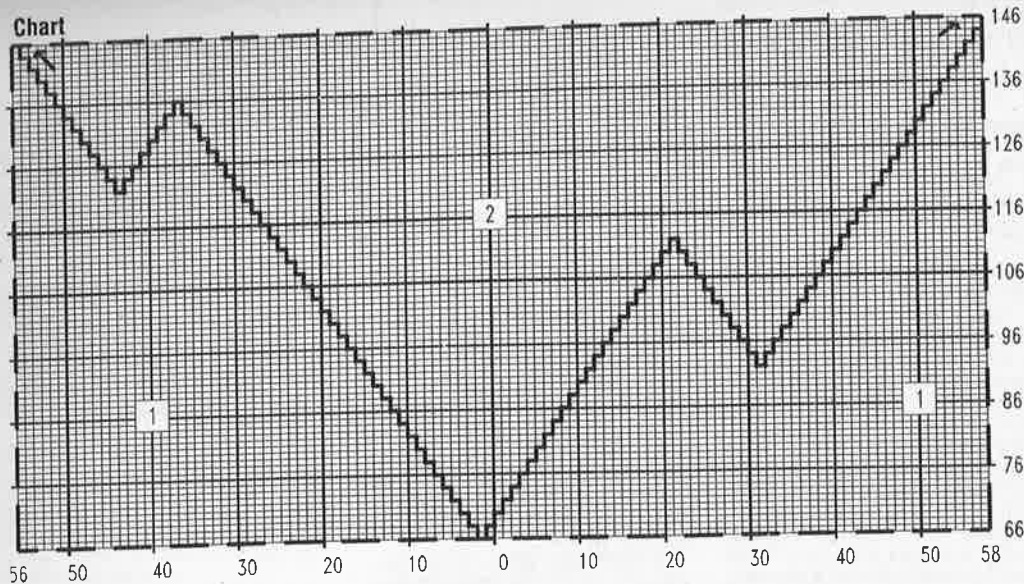

**Key:**  
 1 = Glamour  
 2 = Angora  
 1 square = 1 st and 1 R

# MODEL 15

## DK. RED SWEATER WITH DIAMONDS

**Size:** 12/14.

**Machines:** Suitable for chunky machines with ribber and intarsia carriage. We used a Brother KH 230.

**Material:** PHILDAR "Coton d'Egypte" (100% cotton, 85m/50g) approx. 500g Tibetain. "Mogador" (82% viscose, 12% acrylic, 6% polyester, 86m/50g) approx. 100g each Muscade and Cassis. "Canelis" (67% acrylic, 33% viscose, 117m/50g) approx. 60g Noir. "Phil'Angora" (70% Angora, 30% lambswool, 33m/10g) approx. 60g Noir. "Sunset" (65% acetate, 35% polyester, 160m/20g) approx. 40g Or. You will also need 12 rhine stones in matching colour and gold sequin strip. 4mm crochet hook.

**Tension:** 19 sts and 25-26 rows = 10cm at TD approx. 7.

**Ribs:** 2/2 rib at TD 0.

**Intarsia:** Knitted from the chart as given. Take care to cross the yarns when changing colours to avoid holes. Arrows on diagrams denote direction of knitting.

**Front:** Cast on with waste yarn 110 sts and knit several rows. Set RC 000 and work in intarsia from chart. Mark both edges with yarn at RC 61. Knit to RC 124 and shape neck as shown on chart. At RC 136, cast off rem. sts. Repeat for other side.

**Back:** Cast on and knit as for front. Use the higher neckline as shown.

**Sleeves:** Cast on with waste yarn 80 sts and knit several rows. Set RC 000 and work from chart 2. Work increases as shown on chart. At RC 92, cast off all 110 sts.

**Wells:** Pick up sts from lower edge of back or front and place on 90 needles, dec. evenly across the row. Knit 1 row st st in Coton d'Egypte. Transfer for rib and knit 30 rows. Cast off.

**Cuffs:** Pick up sts from lower edge of sleeves and place on 48 needles, decreasing evenly across the row. Knit 1 row st st in Coton d'Egypte. Transfer for rib and knit 30 rows. Cast off.

**Finishing:** Sew sequin strip around diamond shapes. Sew on rhine stones. Close shoulder seams. Set sleeves between markers. Close side and sleeve seams. If wished, crochet around

neckline in Coton d'Egypte several rows dc's and finish with 1 row crab-stitch.

Chart 1 (front and back)

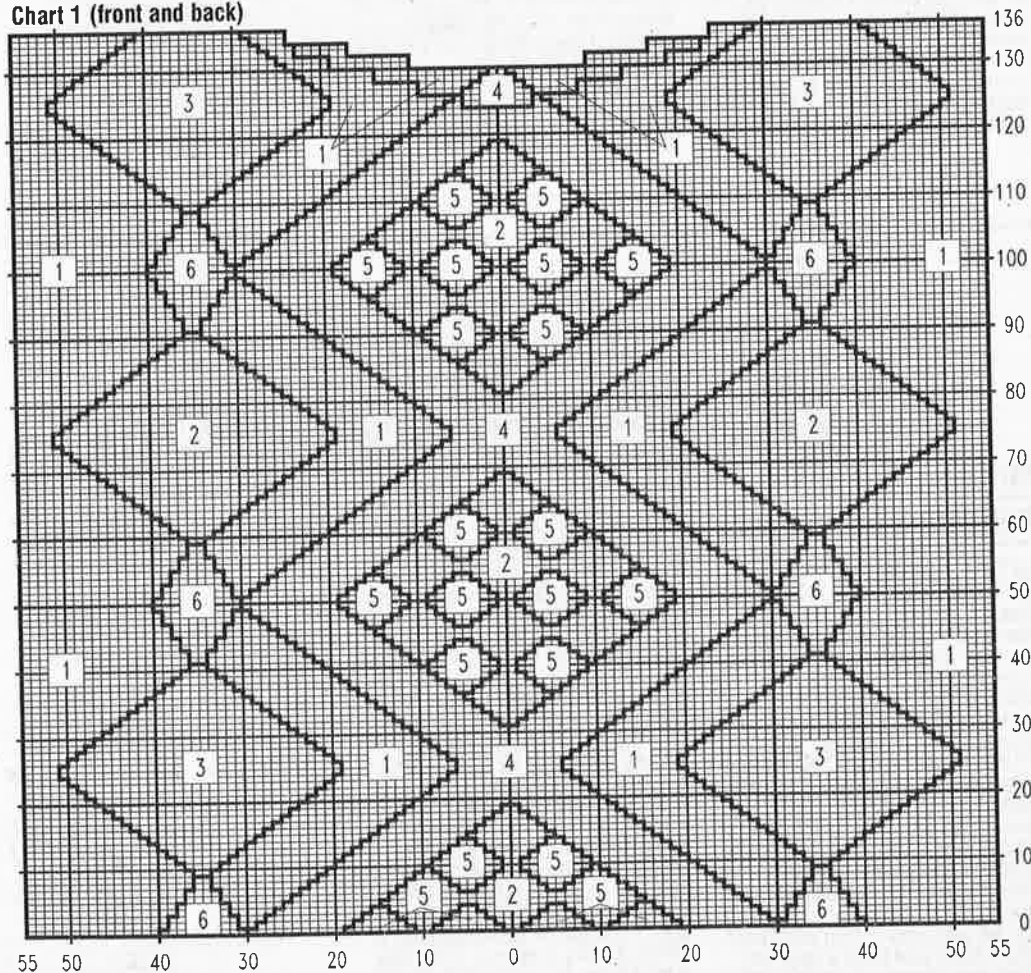

**Key:**  
 1 = Coton d'Egypte Tibetain  
 2 = Angora black

3 = Mogador Muscade  
 4 = Mogador Cassis  
 5 = Canelis Or double

6 = Sunset Or triple strand  
 1 square = 1 st and 1 R

Chart 2 (1/2 sleeve) Model 15

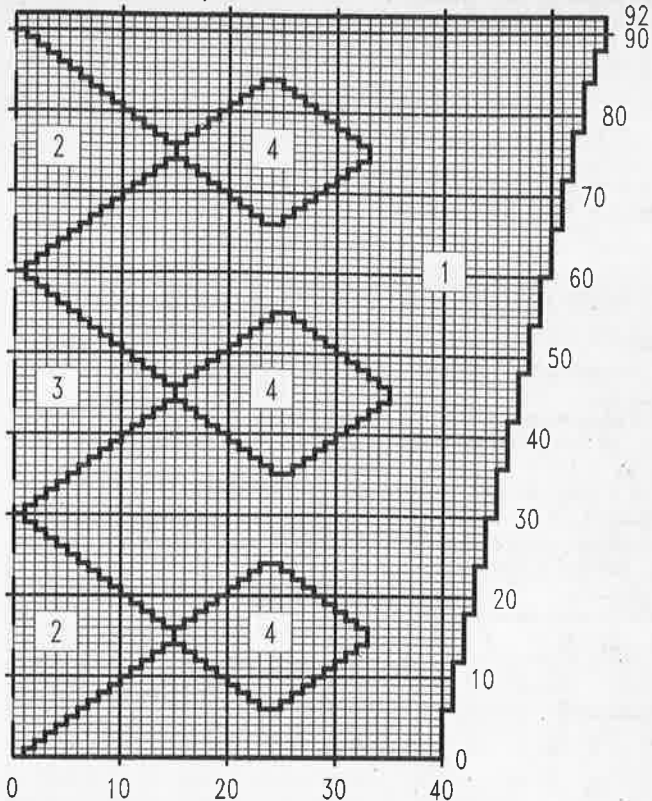

**Key:**  
 1 = Coton d'Egypte Tibetain  
 2 = Angora black  
 3 = Mogador Muscade  
 4 = Mogador Cassis  
 5 = Canelis Or double  
 6 = Sunset Or triple strand  
 1 square = 1 st and 1 R

Diagram model 15

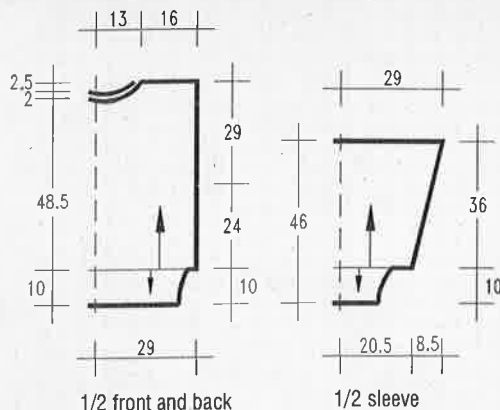

Stitch World Pattern 490

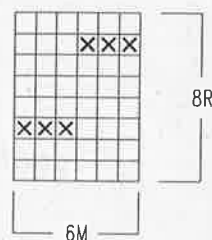

**Front:** Cast on and knit as for back.  
**Sleeves:** E-wrap cast on in cotton 142(154) sts and knit in garter stitch pattern. Decrease 1 st at each side on every 5th row fully fashioned 30(32) times = 82(90) sts. At RC 154(164), reduce sts evenly to 60(64) sts. Knit 40 rows rib ans cast off.  
**Finishing:** Close shoulder seams, leaving 22cm open in centre. Set in sleeves and close rem. seams.

cont. next page

# MODEL 16

## WHITE PATTERNED SWEATER

**Size:** 10/12 (14/16). Instructions for the larger size are in brackets. One figure only applies to all sizes.

**Machines:** Suitable for standard gauge machines with garter carriage and lace carriage. We used a Brother KH 930.

**Material:** SCHACHENMAYR "Bagnola" (100% cotton, mercerised, 180m/50g) approx. 350(400)g soft white. "Angora" (70% Angora, 20% wool, 10% polyamid, 85m/50g) approx. 175(200)g soft white.

Available as a complete kit from Christie Haegele, Burg-Windeck-Str. 4b, 7580 Bühl/Baden, Germany. Send Eurocheque for DM 201.50 (DM 235.50) incl. postage. You will also need 3mm and 7mm knitting needles.

**Tension:** 28-29 sts and 45 rows = 10cm. Measured over garter stitch pattern at TD 7. The sweater is wider at the top because of the pattern arrangement.

**Ribs:** 2/2 rib at TD 4 knitted with garter carriage. Stitch World Pattern No. 534.  
**Garter stitch pattern:** Pattern No. 490 set for Double Width and Height. Punch

card, doubling up on rows and stitches.

**Lace pattern:** Pattern No. 163 at TD 7. Punch card as shown or transfer sts hand following chart given. Knit 2 rows after each transfer and repeat rows 1-8.

**Blackberry stitch:** Remove knitting from machine on to 3mm knitting needles. Knit 1 row st st with single strand Angora, decreasing sts as given in pattern. Change to 7mm needles and use Angora double. Row 2: Edge stitch, \* out of 1 st knit 3 (kl, pl, kl), purl foll. 3 sts together. Repeat from \*. Row 3 and 5: knit. Row 4: Edge stitch, \* purl 3 sts together, knit 3 sts out of next stitch, repeat from \*. Repeat rows 2-5. When knitting row 41 (knit sts), increase sts to number given in pattern. Re-hang work on MB needles, wrong side facing.

**Arrows** on diagrams denote direction of knitting.

**Back:** Cast on 140(152) sts in cotton and knit 40 rows rib. Set RC 000 and change to garter stitch pattern. Knit to RC 100. Take work off machine on knitting needles. Work 1 row knit, reducing sts to 106(118) by knitting together every 3rd and 4th stitch 34 times. Knit the 40 rows of blackberry stitch. On row 41, increase to 128(140) sts, by knitting extra sts out of the cross threads - once from stitch 2(8), 20 times out of every 5th stitch and once out of 2nd(8th) stitch. Knit 64 rows lace pattern with Angora single strand. In cotton knit 28 rows rib and cast off.

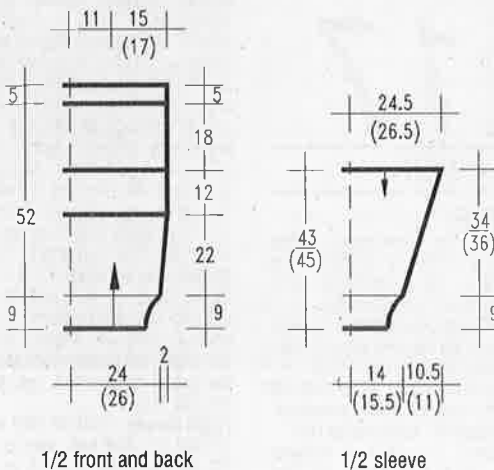

Stitch World Pattern 163

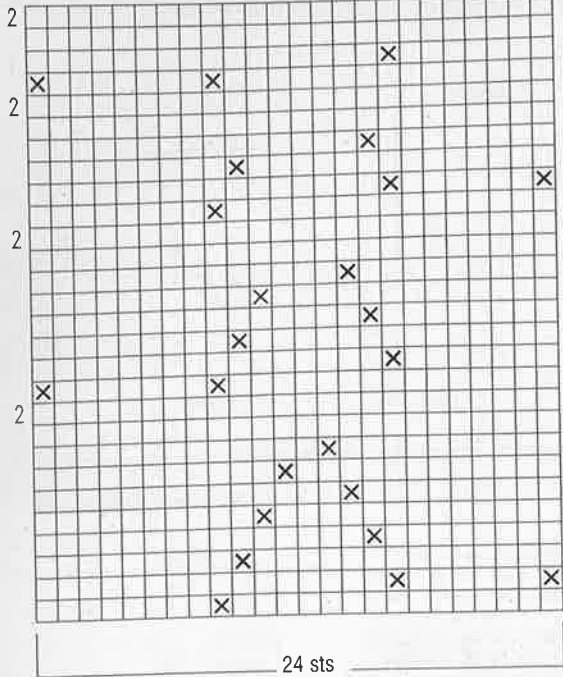

Lace Pattern for hand transfer

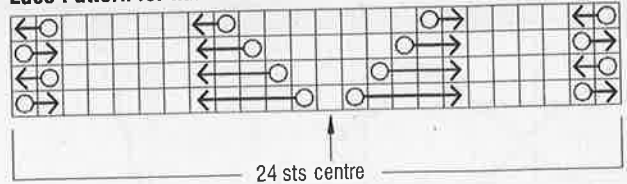

Key:

- = 1 st
- ◁○ = transfer 1 st to N at left, empty N in WP
- ▷ = as above to the right
- ◁◻ = using 2-prong transfer tool, move 2 sts to left by 1 N. Empty N in WP.
- ◻▷ = as above, but to the right
- ◁◻◻ = using 3-prong transfer tool, move 3 sts to left by 1 N. Empty N in WP.
- ◻◻▷ = as above but to the right
- ◻◻◻▷
- ◻◻◻◻▷

MODEL  
RED FLOWER  
SWEATER

17

**Size:** 10/12 (14/16). Instructions for the larger size are in brackets. One figure only applies to both sizes.  
**Machines:** Suitable for standard gauge machines with ribber and intarsia carriage. We used a Brother KH 930.  
**Material:** HAMBURGER WOLFFABRIK Cotton (80% cotton, 20% polyacryl, 150m/50g) approx. **550(600)g red.** Small amounts of cotton or viscose yarn in dk., royal and lt. blue. Lt. and dk. green, white and yellow.  
 Available as a complete kit by mail-order from STRICKSTUDIO HAMBURG, Barenfelder Str. 168, 2000 Hamburg 50, Germany. Send Eurocheque for DM 160.00 incl. postage.  
**Tension:** 29 sts and 37 rows = 10cm at TD 9.  
**Ribs:** 1/1 rib at TD 3.  
**Intarsia:** Knitted from chart at TD 9. Smaller areas may also be swiss-darned.  
**Arrows** on diagrams denote direction of knitting.  
**Front:** Cast on 156(168) sts in red and knit 32 rows rib. Transfer all sts to MB and set RC 000. Knit in intarsia following the chart to **RC 120.** Shape arm-

holes. Set multi-transfer tool with 6 prongs out. \* At each side, move 6 sts in by 3. Knit 6 rows. Repeat from \* 6(7) times = 21(24) sts decr. each side. Knit to **RC 180** and shape neck. Push centre 38 sts and all sts at side opposite to carriage to HP. Knit each side separately. At neck edge push to HP on alt. rows 1 st 5 times. Knit to **RC 210** and cast off. Repeat for other side. Return needles from HP to WP. Pick up 20 sts at each side from straight edge = 88 sts. Knit 1 row st st. Transfer for rib and knit 14 rows. Cast off.  
**Back:** Cast on and knit as for front, knitting intarsia flowers in your own choice. Knit the higher neckline as shown on the chart by HP shaping. Knit neckband as on front, but without additional sts.  
**Right sleeve:** Cast on with waste yarn 82(92) sts and knit several rows. Set RC 000 and knit in st st, increasing 1 st at each side on every 5th row 21(22) times = 124(136) sts. When **RC shows 108(112)** shape top. Decrease 3 sts at each side on every 6th row 7(8) times as described for front = 82(88) sts. Knit to **RC 184(190)** and cast off.  
**Left sleeve:** Cast on and knit as for right sleeve, including the lower flower from chart in the centre.  
**Cuffs:** Pick up sts from lower edge of sleeve and hang on 70(74) needles, decreasing evenly across the row. Knit 1 row st st. Transfer for rib and knit 44 rows. Cast off.  
**Finishing:** Close all seams. Set in sleeves, matching the decreases. Pleat the top to fit.

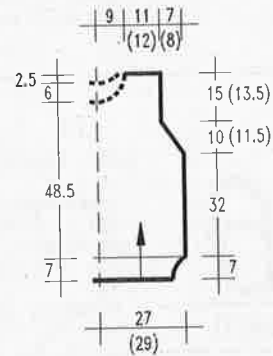

1/2 front and back

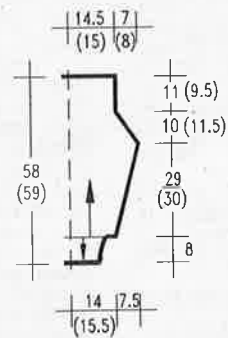

1/2 sleeve

Use yarn of similar meterage when substituting yarns!

Chart (back or front)

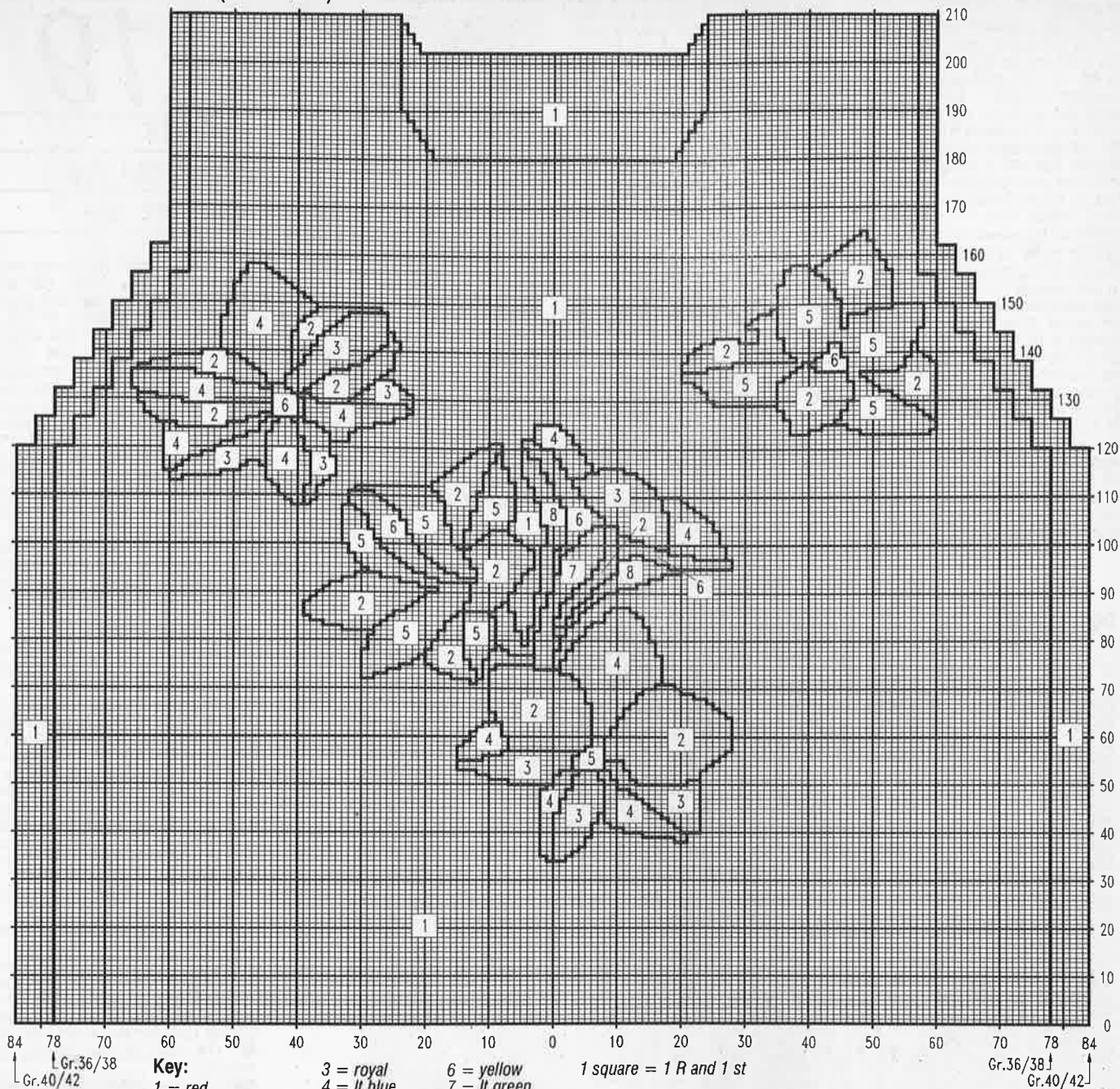

**Key:**

1 = red  
2 = dk.blue

3 = royal  
4 = lt.blue  
5 = white

6 = yellow  
7 = lt.green  
8 = dk.green

1 square = 1 R and 1 st

# MODEL 18

## BLACK SWEATER WITH DIAMONDS

**Size:** 12/14 (16/18). The instructions for the larger size are in brackets. One figure only applies to all sizes.

**Machines:** Suitable for electronic standard gauge machines with ribber.

**Material:** HAMBURGER WOLFFABRIK Cotton (80% cotton, 20% polyacryl,

150m/50g) approx. **550(600)g black.** A small amount of red silk or viscose. Gold Lurex yarn.

The yarn is available by mailorder from STRICKSTUDIO HAMBURG, Barenfelder Str.168, 2000 Hamburg 50, Germany. Send Eurocheque for DM 145.00 incl. postage.

**Tension:** 27-28 sts and 34 rows = 10cm at TD 9\*\*

**Ribs:** 2/2 rib at TD approx. 3.

**Fairisle pattern:** Program machine or mark mylar sheet. Use Single Motif setting. Before knitting, set Switch 6 UP to reverse needle selection. Pattern 2 is programmed to knit from row 1 to 54 and then from row 54 to row 1.

cont. next page

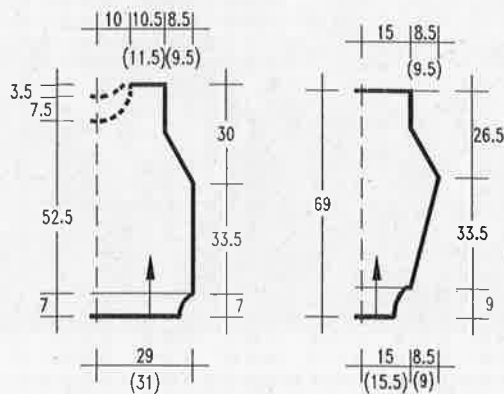

1/2 front and back

1/2 sleeve

## MODEL SWEATER IN PATTERN AND YARN MIXTURE

**Size:** 12 - 16.  
**Machines:** Suitable for chunky machines with intarsia carriage. Ribs are knitted by hand or on standard gauge machine. We used a Brother KH 260.  
**Material:** WSM "Soft" (100% cotton, 90m/50g) approx. **400g red.** "Frou Frou" (80% viscose, 20% polyamid, 80m/50g) approx. **150g black and 100g red.** "Angora Nova" (75% Angora, 25% lambswool, 95m/20g) approx. **40g black and 20g red.** "City" (100% cotton, 125m/50g) approx. **100g red.** "Deco" (45% Lurex, 37% acetate, 18% polyamid, 57m/25g) approx. **25g each in black and red.** A small amount of ribbon yarn in gold.

Available as a kit by mailorder from E&S Strickstudio, Zinnigbergasse 9, 8015 Markt Schwaben, Germany. Send Eurocheque for DM 180.15 incl. postage.

**Tension:** 20 sts and 33 rows = 10cm at TD 3 over intarsia. 20 sts and 36 rows at TD 3 over tuckstitch.

**Intarsia:** Knitted from charts 1 and 2 at TD 3. For chart 1 rows 1-50 are not included. These rows are knitted in tuckstitch. Knit several rows waste-yarn and release from machine. Re-hang on same needles, wrong side facing. At **RC 120**, start V-neck by knitting by right side first. Release sts of left side on to waste yarn and reverse work before knitting the tuckstitch area.

**Tuckstitch:** Knitted with Card 5 from basic set or punch card as given.

**Arrows** on diagrams indicate direction of knitting.

**Front:** Cast on with waste yarn 114 sts and knit several rows. Set RC 000 and knit with Soft in red 50 rows tuckstitch. Turn the work and follow chart 1 for intarsia. Read decreases from chart. At **RC 174**, cast off rem 30 sts for shoulder.

**Back:** Cast on and knit as for front, reversing the pattern.

**Right sleeve:** Cast on with waste yarn 60 sts and knit several rows. Set RC 000 and knit from chart 2, reading the increases at sides from chart.

**Remember** to turn work after row 20! Cast off all at RC 120.

**Left sleeve:** Cast on with waste yarn 60 sts and knit several rows. Set RC 000 and continue with Soft in red and knit tuckstitch. Increase 1 st at each side on every 5th row 17 times and on every 4th row 10 times = 114 sts. Cast off all sts at RC 130.

**Welts:** Pick up sts from lower edge of front or back and put on knitting needles. With City knit 1 row st st. Knit 38 rows in kl, pl rib. Cast off.

**Cuffs:** Pick up sts from lower edge of sleeves and knit as for welts for 38 rows. Cast off.

**Neckband:** Close shoulder seams. With circular knitting needle pick up 37 sts from each of the 4 straight edges plus 1 st from each corner = 150 sts.

Chart 1 for Model 18

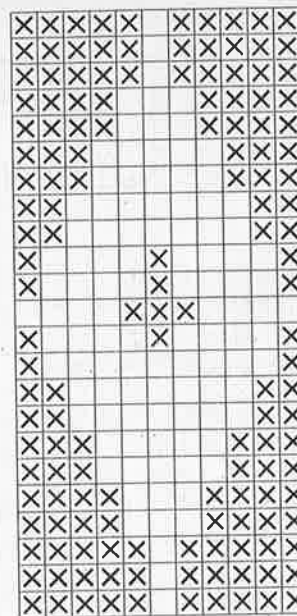

**Arrows** on diagrams indicate direction of knitting.

**Front:** Cast on in black 160(172) sts in 2/2 rib and knit 30 rows. Transfer all sts to MB and set RC 000. Knit in st st to **RC 10**. With gold Lurex, knit one diamond from chart 1, followed by the large diamond in red and a small diamond in gold. Continue in black st st to **RC 114** and shape armholes. Set multi-transfer tool with 6 prongs out. \* At each side move the outer 6 sts in by 3 and put empty needles in NWP. Knit 6 rows. Repeat from \* 7(8) times = 24(27) sts decreased at each side. Knit straight to **RC 178** and shape neck. Push to HP the centre 36 sts and all sts at side opposite to carriage. Knit each side separately. At neck edge push to HP on alt. rows 1 st 9 times. Knit straight to **RC 216** and cast off rem. 29(32) sts for shoulder. After knitting the 2nd side, return sts from HP to WP, picking up 18 sts at each side from straight edge = 90 sts. Knit 1 row st st. Transfer for 2/2 rib and knit 15 rows. Cast off.

**Back:** Cast on and knit as for front to **RC 204**. Shape neck. Push to HP the centre 44 sts and all sts at side opposite to carriage. Knit each side separately. Push to HP at neck edge on alt.

rows 1 st 5 times. Cast off rem. 29(32) sts at **RC 216**. After knitting 2nd side, return sts from HP to WP and knit 1 row st st. Transfer sts for rib and knit 15 rows. Cast off.

**Sleeves:** Cast on in 2/2 rib 82(84) sts and knit 40 rows. Transfer all sts to MB. Set RC 000. Shape sides by incr. 1 st at each side on every 5th row 15(4) times and on every 4th 9(22) times to 130(136) sts. AT THE SAME TIME, knit motifs as follows: On row 20 one diamond from chart 1 in gold. Knit 21 rows black. Knit one diamond from chart 1 in red. Knit 21 rows black. Knit one diamond from chart 1 in gold. Continue in black to **RC 114**. Shape top. Decrease 3 sts at each side as described for front 8(9) times altogether = 82 sts. Knit straight to **RC 204** and cast off.

**Finishing:** Close all seams. Set in sleeves, gathering the top to fit. Take care to match the decreases.

Chart 2 for Model 18

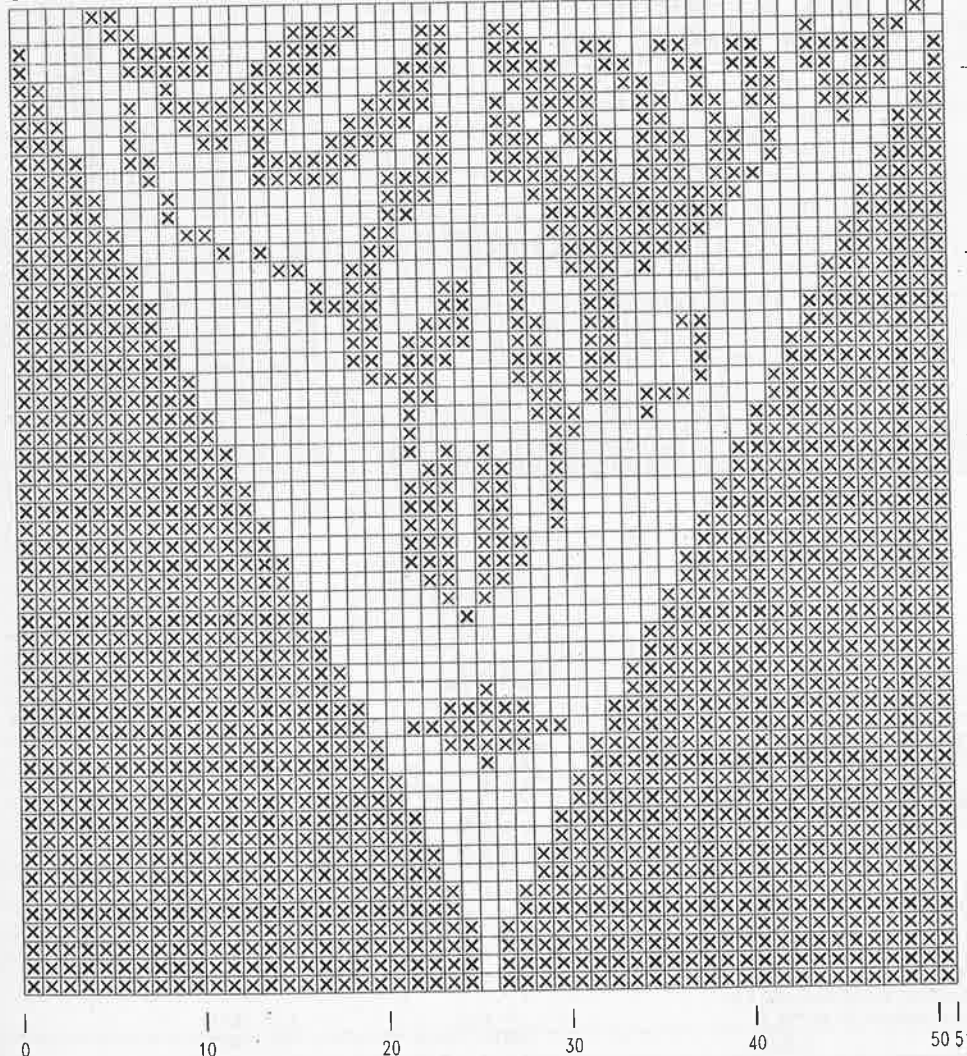



**Chart 2 (sleeves)**

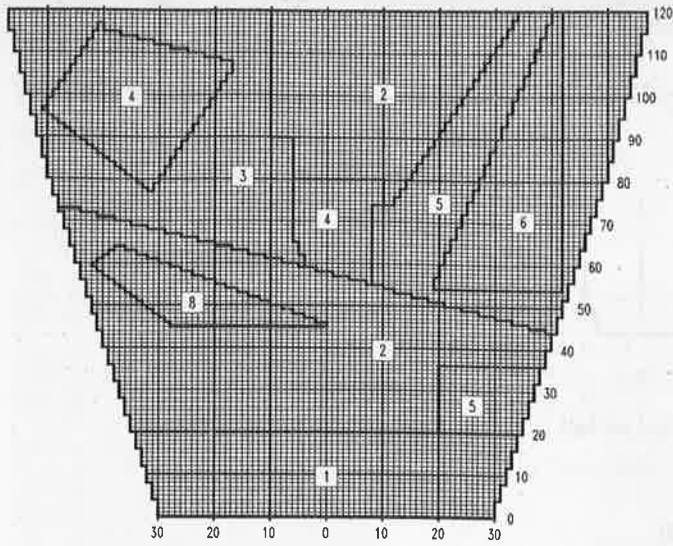

Knit in st st with Soft, decreasing at corner by slipping stitch before marked stitch; k2 tog and pull slipped stitch over. Knit 8 rows in Soft red. Knit 4 rows in Frou Frou and cast off with Soft red.

**Finishing:** Set in sleeves and close side and sleeve seams.

**Key:**

- 1 = Soft Tuckstitch Card 5
- 2 = Frou Frou black st st
- 3 = Frou Frou red st st
- 4 = Angora Nova black st st
- 5 = Angora Nova red st st
- 6 = Deco black st st
- 7 = Deco red st st
- 8 = gold viscose
- 1 square = 1 R and 1 st

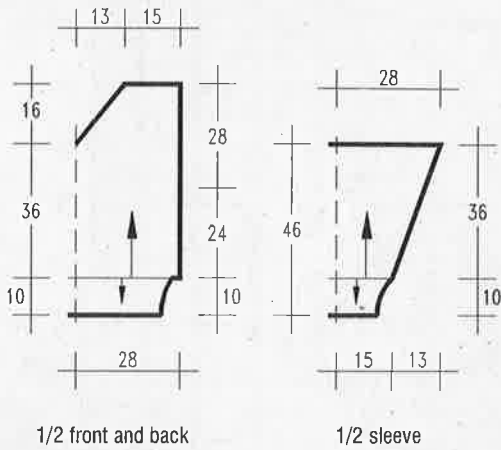

**Punchcard**

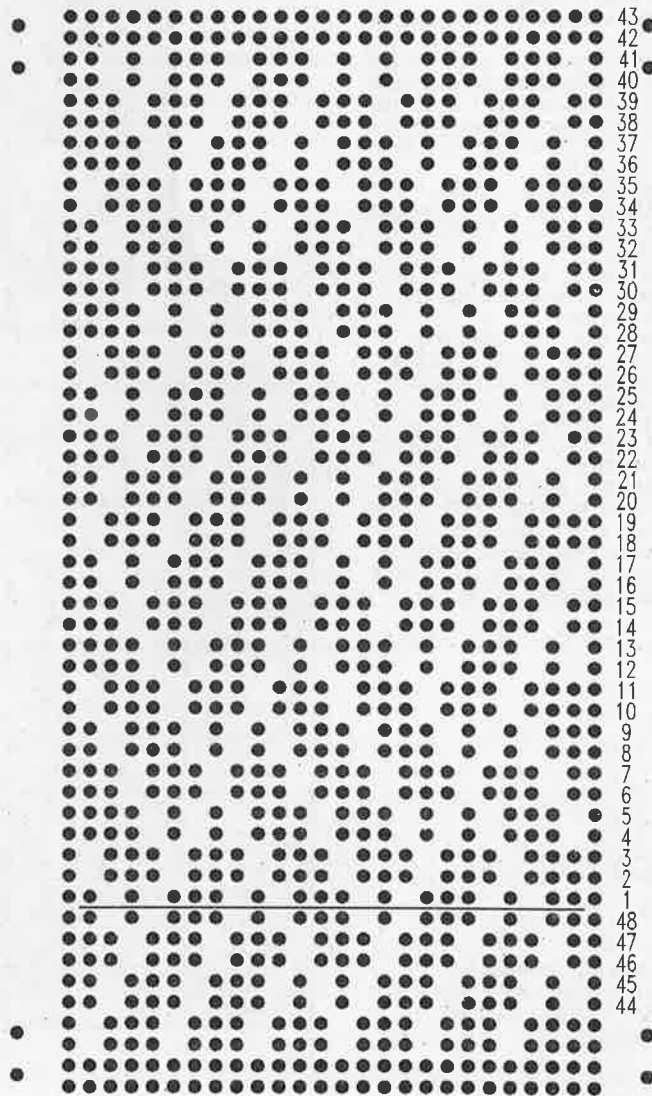

**Chart 1 (front or back)**

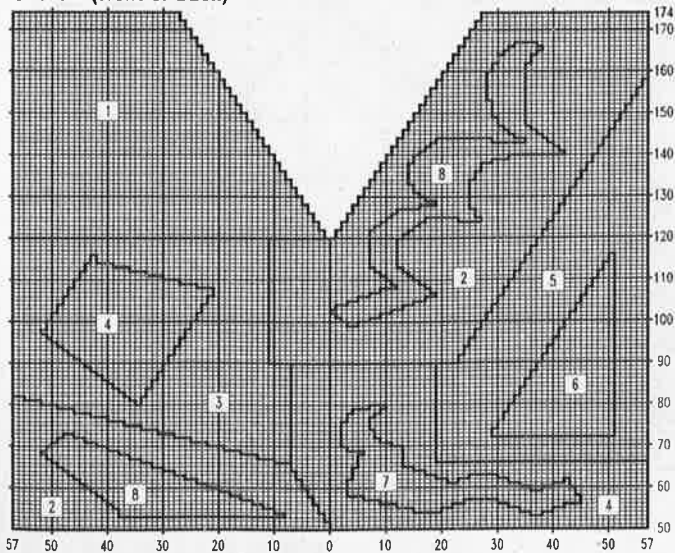

# MODEL 20

## PINK SWEATER WITH COLOURED DIAMONDS

Size: 12 - 16.

**Machines:** Suitable for standard gauge machines with ribber and intarsia carriage. We used a Brother KH 891.

**Material:** SCHACHENMAYR "Bagnola" (100% mercerised cotton, 180m/50) approx. 500g pink. "Angora", 20% wool, 10% polyamid, 85m/50g) approx. 25g each in black, white and turquoise. Small amount gold Lurex and salmon silk.

The yarn is available from Christl Haegele, Burg-Windeck-Str.4b, 7580 Bühl/Baden, Germany. Send Eurocheque for DM 145.00 incl. postage.

**Tension:** 28-29 sts and 35 rows = 10cm at TD 7\* knitted with Bagnola.

**Ribs:** 2/2 rib at TD 3\*\*

**Intarsia:** Knitted at TD 7\* from charts 1 and 2. On chart 2 the pattern is reversed for left side. Cross yarns on back when changing colour.

**Arrows** on diagrams indicate direction of knitting.

**Front:** Cast on in pink 164 sts and knit 60 rows rib. Transfer all sts to MB. Now work intarsia from chart 1. At **RC 108**, shape armholes. \* With multi-transfer tool, move 6 sts at each side in by 3. Knit 4 rows. Repeat from \* 7 times = 24 sts decreased at each side. Knit to **RC 180** and shape neck as shown on chart. Cast off rem. 30 sts for the shoulders.

**Back:** Cast on and knit as for front, shaping the neck from **RC 198** as shown on chart.

**Sleeves:** Cast on 92 sts in pink and knit 54 rows 2/2 rib. Transfer all sts to MB. Set RC 000 and knit, following chart 2 and reversing pattern for left side. At **RC 100**, shape top as described for front. Knit straight to **RC 198** and cast off rem. 96 sts.

**Neckband:** In pink, cast on 130 sts in 2/2 rib and knit 8 rows at TD 3\*\* and 10 rows at TD 4. Cast off loosely.

**Finishing:** Close shoulder seams. Sew in neckband. Close rem. seams. Set in sleeves, gathering top to fit.

### Key:

- 1 = pink
- 2 = black
- 3 = white
- 4 = turquoise
- 5 = gold
- 6 = salmon
- 1 square = 1 R and 1 st

- = 1 hole (transfer marked st to the left, empty N in WP)
- ⊢ = cable 6 sts with 2x3 prong transfer tools

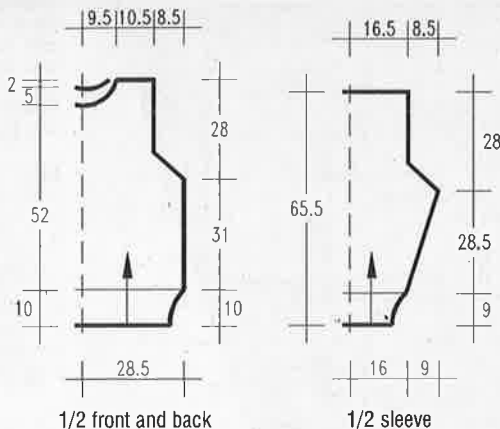

Chart 1 (front or back)

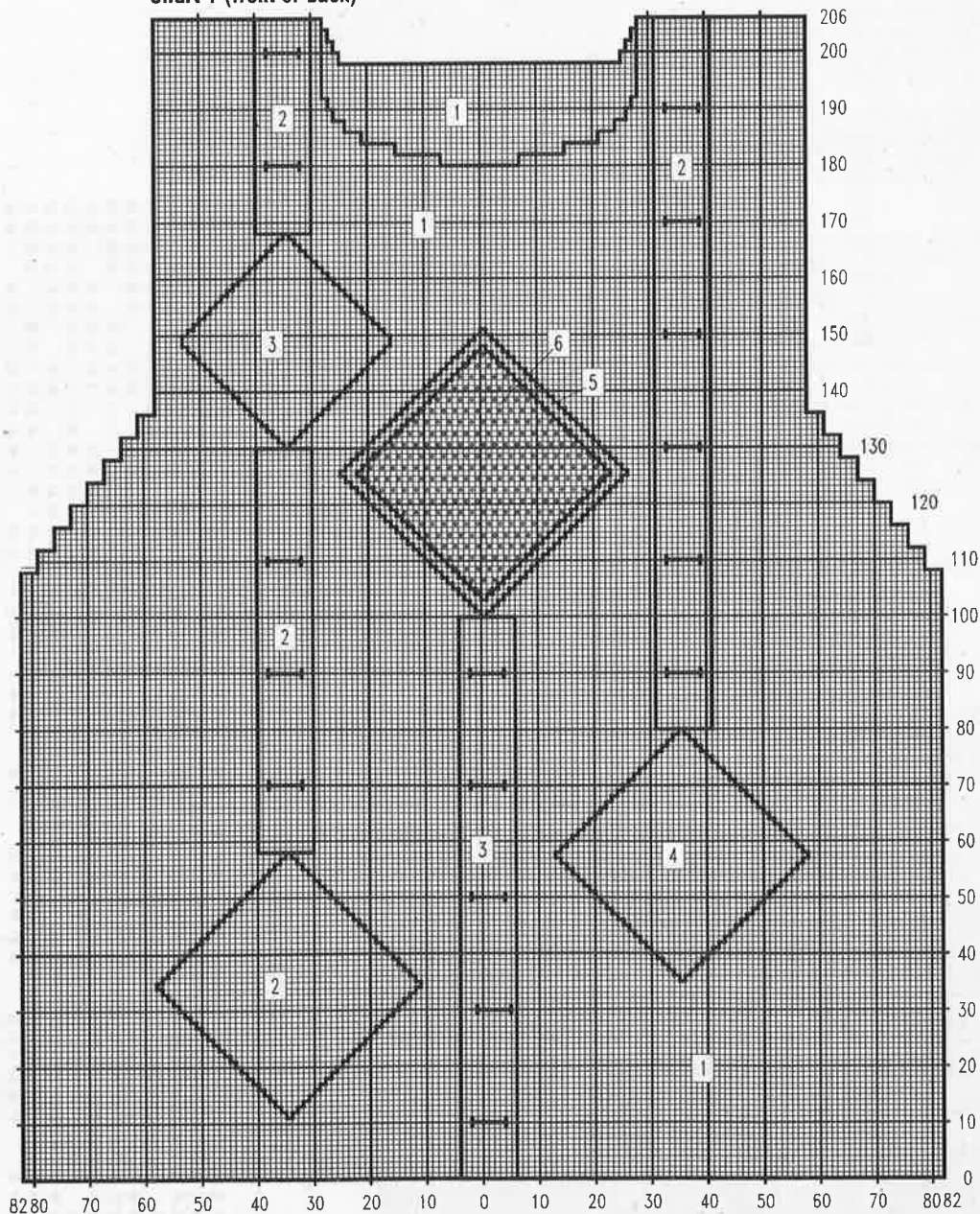
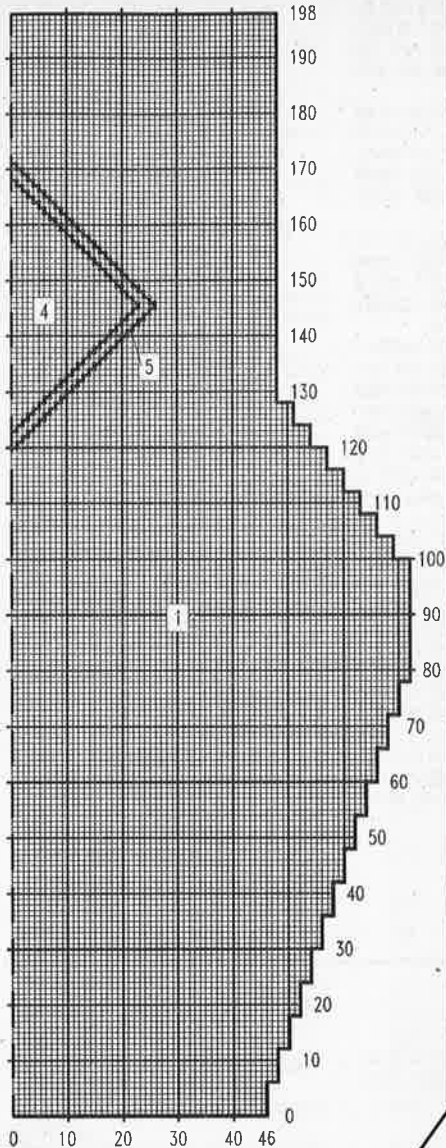

Chart 2 (1/2 sleeve) Model 20



Key:  
 1 = pink  
 4 = turquoise  
 5 = gold  
 1 square = 1 R and 1 st

# MODEL 21

## BLACK SWEATER WITH COLOURED DIAMONDS

Size: 12/14 (16/18). The instructions for the larger size are in brackets. One figure only applies to all sizes.

Machines: Suitable for standard gauge machines with ribber and intarsia carriage. We used a Brother KH 930.

Material: HAMBURGER WOLFFABRIK Cotton (80% cotton, 20% polyacryl, 150m/50g) approx. 550(600)g in

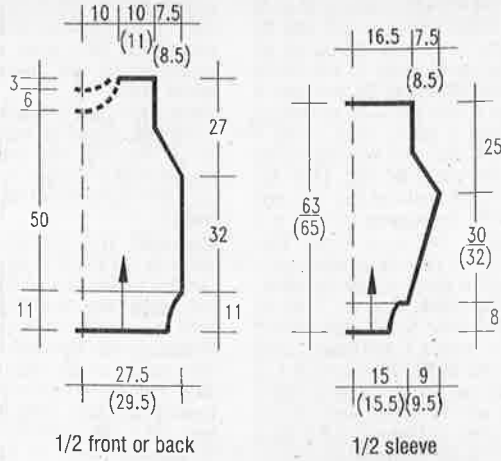

**black.** Small amounts of viscose in turquoise, pink purple and white. The yarn is available by mailorder from STRICKSTUDIO HAMBURG, Barenfelder Str. 168, 2000 Hamburg 50, Germany. Send Eurocheque for DM 145.00 incl. postage.  
**Tension:** 27-28 sts and 34 rows = 10cm at TD 9\*\*  
**Ribs:** 2/2 rib at TD 3.  
**Intarsia:** Knitted from chart for model 21. Cross yarns at back when changing colours.  
**Arrows** on diagrams indicate direction of knitting.

**Front:** In black cast on 152(164) sts in 2/2 rib and knit 52 rows. Transfer all sts to MB. Knit from chart. At RC 110, shape armholes. \* With multi-transfer tool move 6 sts at each side in by 3. Knit 6 rows. Repeat from \* 6(7) times = 21(24) sts in decreased at each side. Continue to RC 170 and shape neck, pushing needles to HP as shown on chart for lower neckline. Cast off rem. 28(31) sts at RC 200. Return 54 needles in centre from HP to WP. Pick up 20 sts from each straight edge of neck = 94 sts. Knit 1 row st st. Transfer sts for rib and knit 14 rows. Cast off.  
**Back:** Cast on and knit as for front, setting the diamonds the same or at random. Shape neckline as given for front. Knit neckband over 54 sts in HP only.  
**Sleeves:** Cast on 82(84) sts in 2/2 rib and knit 40 rows. Transfer all sts to MB. Set RC 000 and knit in black st st, increasing 1 st at each side on every 4 th row 25(27) times = 132(138) sts. Include intarsia diamonds in centre if required. At RC 102(110) shape top as described for front. Knit on rem. 90 sts to RC 188(196) and cast off.  
**Finishing:** Close all seams. Set in sleeves, gathering top to fit. Take care to match the decreases.

Key:  
 1 = black  
 2 = turquoise  
 3 = pink  
 4 = lilac  
 5 = white  
 1 square = 1 R and 1 st

Chart for Model 21

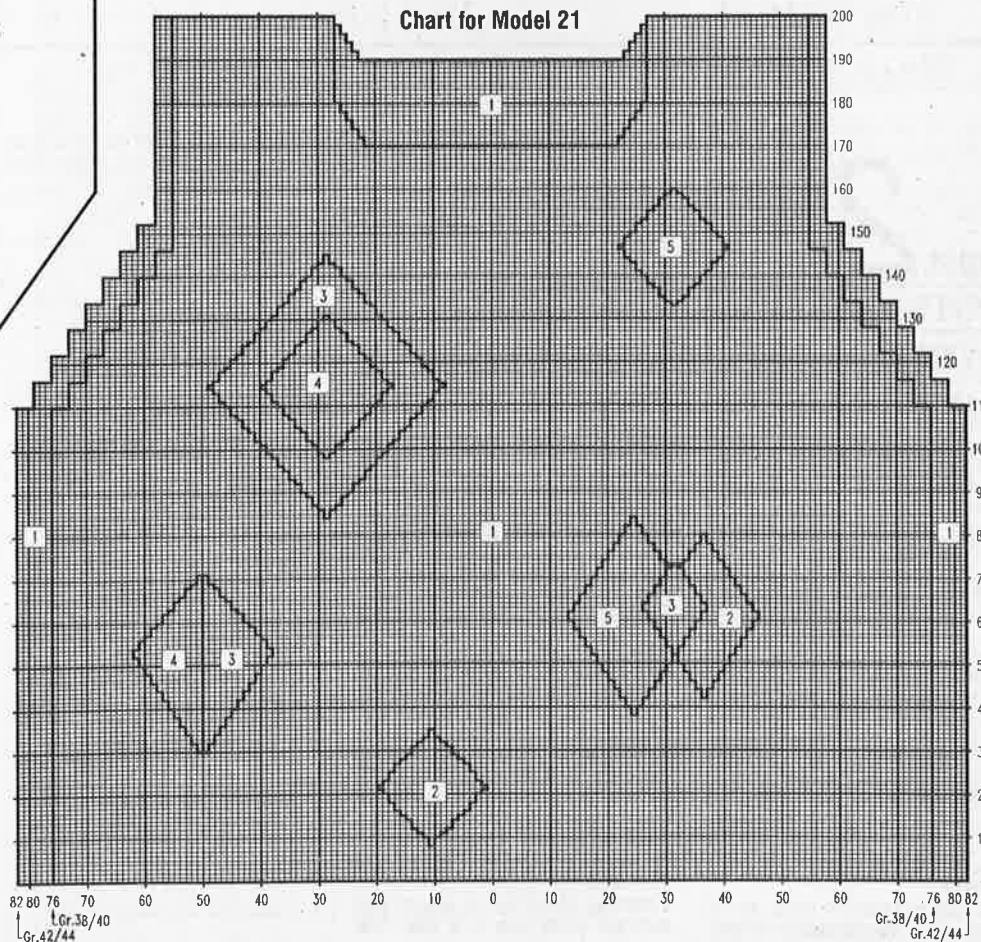

# MODEL 22

## TURQUOISE

### SWEATER

#### WITH PLAIT INSERT

**Size:** 12/14 (16/18). The instructions for the larger sizes are in brackets. One figure only applies to all sizes.

**Machines:** Knitted on Singer Double bed machine. Suitable for machines with 5-9mm gauge.

**Material:** SCHACHENMAYR "Coletta" (80% mercerised cotton, 20% polyester, 90m/50g) approx. **700(750)g** turquoise. "Opera" (100% viscose, 95m/50) approx. **200g** emerald.

The yarn is available by mailorder from Christl Haegele, Burg-Windeck-Str. 4b, 7580 Bühl/Baden, Germany. Send Eurocheque for DM 119.00 (125.50) incl. postage.

**Tension:** 22 sts and 28 rows = 10cm at TD 12.

**Ribs:** 1/1 rib at TD 5/5.

**Arrows** on diagrams indicate direction of knitting.

The sweater consists of 2 side pieces: back and front with sleeves, a V-insert for front and back and the plait insert.

**Side piece with sleeves:** Cast on at left of needle bed 47(53) sts with

waste yarn and knit several rows. Set RC 000 and knit with Coletta in st st. At RC 56, shape V-front on left side by decreasing 1 st fully fashioned on every 3rd row 40 times. AT THE SAME TIME, when RC shows 82, increase at right edge for the sleeve on alt. rows 2 sts 4 times, 3 sts 13 times, 5 sts 7 times and 15 sts once. Keep right edge straight and knit to RC 180, 140(110) sts. This is the shoulder line. Now knit downwards, decreasing at right and increasing at left edge. At RC 360, release rem. 47(53) sts on waste yarn. Knit a second piece exactly the same.

**V-insert for back:** Cast on 4 sts by hand with Coletta. Set RC 000 and knit in st st. On rows 3, 6 and 9 incr. 1 st at side. **10 sts at RC 10.** Increase 1 st fully fashioned on each side on every foll. 3rd row 24 times. Don't fill the empty needle, just leave in WP to form a hole. At RC 80, shape neck. Push to HP the centre 28 sts and all sts st side opposite to carriage. Knit each side separately. At neck edge, push to HP on alt. rows 5 sts once and 2 sts once. Cast off rem. 5 sts at RC 88. Repeat for other side. Knit 1 row over N in HP and cast off loosely.

**V-insert for front:** Cast on and knit as for back to RC 70. Shape neck by pushing to HP the centre 20 sts and all sts at side opposite to carriage. Knit each side separately. At neck edge push to HP on alt. rows 4 sts once, 3 st once, 2 sts once and 1 st 5 times. Finish as for back insert.

**Long strip:** Cast on with waste yarn 28 sts and knit several rows. Set RC 000 and arrange needles as follows: centre

2 sts on RB, 5 sts each side on MB, 1 st each side on RB, 5 sts each side on MB, 1 st each side on RB and 1 st each side on MB. With Opera, knit with this setting to RC 360. Release sts with waste yarn.

**Short strip:** Cast on and knit as above to RC 266. Shape left edge. \* Cast off on alt. rows 1 st once and 2 sts once. Repeat from \* 8 times. On last repeat cast off 3 sts once. At RC 302, no sts remain.

**Neckband:** With Coletta cast on 150 sts in rib and knit 20 rows. Push empty needles to WP and at TD 7/7, knit 3 rows separately on each bed. Release from machine on waste yarn.

**Finishing:** With right side out, lay the 2 main pieces on the table. Lay the long strip along the left piece from the back down to the front. Sew on with mattress stitch, leaving the last 20cm open for the twist effect. Set the short strip with the point in the back and stitch in as far as the twist. Pull the short strip twice around the long strip, pin in position and sew on. Sew in V-insert. Close seam in neckband and attach through open loops with back stitch from both sides.

**Welts:** Cast on 142(148) sts in Coletta and knit 28 rows rib. Transfer all sts to MB. Pick up sts from lower edge of back or front and hang on same needles, decr. evenly across the row. Knit 1 row and cast off.

**Cuffs:** Cast on with Coletta 56 sts in rib and knit 20 rows. Cast off loosely and sew to lower edge of sleeves. Close side seams.

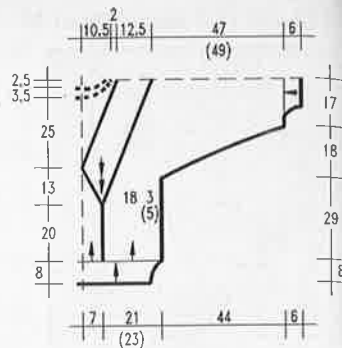

1/2 front or back with sleeve

# MODEL 23

## PURPLE POLO

### SWEATER

**Size:** 10/12 (14/16). The instructions for the larger size are in brackets. One figure only applies to all sizes.

**Machines:** Knitted on Singer Double Bed Machine. Suitable for machines with 5mm gauge.

**Material:** WSM "Lhasa" (50% lambswool, 30% Angora, 10% cashmere, 10% polyamid, 90m/20g) approx. **330(380)g** purple. Alternately use SCHACHENMAYR Jaeger "Angora" (70% Angora, 20% lambswool, 10% polyamid, 90m/20g) approx. **360(380)g** purple.

The alternate yarn is available by mailorder from Christl Haegele, Burg-Windeck-Str. 4b, 7580 Bühl/Baden, Germany. Send Eurocheque for DM 200.00 (219.00) incl. postage.

**Tension:** 21 sts and 29-30 rows = 10cm at TD 11.

**Ribs:** 2/2 rib at TD 5.

**Arrows** on diagrams indicate direction of knitting.

**Back:** Cast on 114(124) sts in rib and knit 25 rows. Transfer all sts to MB.

Knit in st st to RC 102 and shape raglan. Cast off 4(6) sts at beg of next 2 rows. Decrease 1 st at each side on alt. rows 35(38) times. Work the decreases by lifting the 4th stitch on a transfer tool, move 3 outer sts in by 1 and replace the 4th stitch on the 3rd needle. At RC 174(180) cast off rem. 36 sts loosely.

**Front:** Knit and shape as for back till RC shows 156(162). Cast off the centre 10 sts and knit each side separately. At neck edge cast off on alt. rows 4 sts once, 3 sts once, 2 sts once and 1 st once. Keeping neck edge straight, knit to RC 174(180) and cast off rem. 3 sts. Repeat for other side.

**Sleeves:** Cast on with waste yarn 64(68) sts and knit several rows. Set RC 000 and knit in main yarn and st st, incr. 1 st at each side on every 10th row 11 times (on every 8th row 14 times) = 86(96) sts. When RC shows 118, shape raglan as given for back till 8 sts remain at RC 190(196). Cast off.

**Cuffs:** Pick up sts from lower edge of sleeves and hang on 54(58) N on MB, decr. evenly across the row. Knit 1 row. Transfer for rib and hang comb and weights. Knit 25 rows rib and cast off.

**Poloneck:** Cast on 142(148) sts in rib and knit 70 rows. Push empty N to WP and set carriage for circular knitting. Knit 8 rows (4 rows on each bed). Knit several rows waste yarn and release from machine.

**Finishing:** Close raglan seams with mattress stitch from right side. Sew

polo collar to neckline from inside and outside, removing the waste yarn. Close rem. seams.

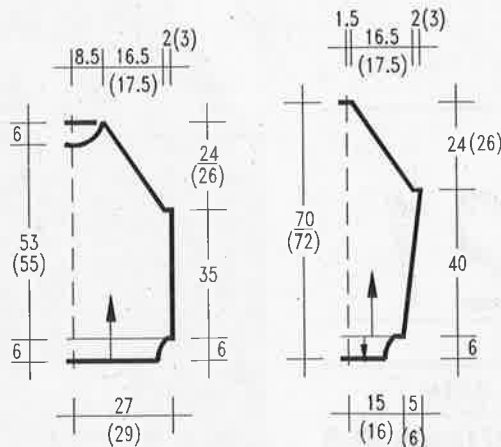

1/2 front and back

1/2 sleeve

# MODEL 24

## PINK SWEATER

Size: 12/14.

**Machines:** Knitted on a Singer Solo Extra wide (126 needles). Suitable for chunky machines with sufficient needles and intarsia carriage.

**Material:** "Ilona" (100% cotton, 130m/50g) approx. 450g pink. "Carlotta" (60% Angora, 30% lambswool, 95m/25g) approx. 20g pink. "Dancing" (50% viscose, 50% acetate, 130m/50g) approx. 50g pink. 50 nopp yarn in pink flecked. Pink accent yarn. The yarn is available by mailorder from Mina's Wollknäuelchen. An der Schaftritt 28, 4470 Meppen, Germany. Send Eurocheque for DM 61,20 incl. postage.

3mm knitting needles. 3mm crochet hook.

**Tension:** 21 sts and 32 rows = 10cm at TD 2 over st st in cotton.

**Ribs:** 1/1 rib on standard gauge machine at TD 4 or knitted by hand on 3mm needles.

**Intarsia:** Knitted from the chart, reversing the pattern for the left side.

**Lace pattern:** On rows 2, 22, 42, 62 and 82 transfer the stitch at right of centre to the left, leaving empty N in WP. Transfer every foll. 8th st across the row. On rows 12, 32, 52, and 72 place holes alternately.

**Arrows on diagrams** indicate direction of knitting.

**Front:** With waste yarn cast on 116 sts and knit several rows. Change to main yarn and set RC 000. Work from chart, reading the shapings as well as the intarsia. Use the markings for the lower neckline.

**Back:** Knit as for front, using the higher neckline.

**Sleeves:** Cast on with waste yarn 70 sts and knit several rows. Set RC 000 and knit in pink cotton, incr. 1 st at each side on every 4th row 19 times = 108 sts. At RC 80, shape top. Cast off at each side on alt. rows 4 sts once, 3 sts once, 2sts twice and 1 st 4 times = 78 sts. Knit straight to RC 142 and cast off at each on alt. rows 2 sts 3 times. Cast off rem. 66 sts.

**Wells:** Pick up sts from lower edge of back or front, reducing them to 96. Knit rib on standard gauge machine or by hand for 50 rows. Cast off.

**Cuffs:** Knit as for wells over 54 sts and 50 rows.

**Finishing:** Embroider on front and sleeves, working 3 horizontal straight sts over 6-7 sts 2 rows apart. Gather the 3 threads in the centre and fasten off. Close shoulder seams. Crochet around neckline 1 row of dc's in pink Angora. Make a chain in Dancing and draw through the crochet row. Close rem. seams and set in sleeves, gathering the top to fit.

### Key:

- 1 = pink cotton lace pattern
- 2 = pink cotton
- 3 = Angora
- 4 = Lurex yarn
- 5 = flecked nopp yarn
- 6 = pink cotton with pink accent yarn
- 1 square = 1 R and 1 st

Chart (1/2 front or back)

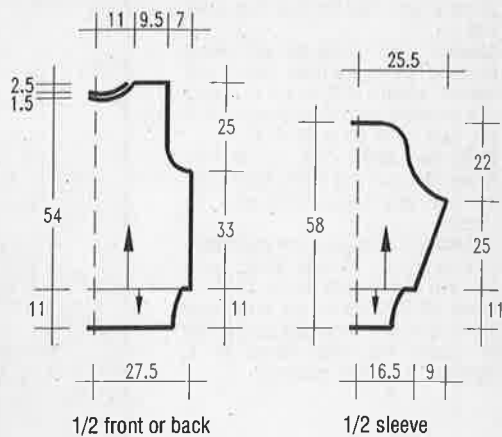
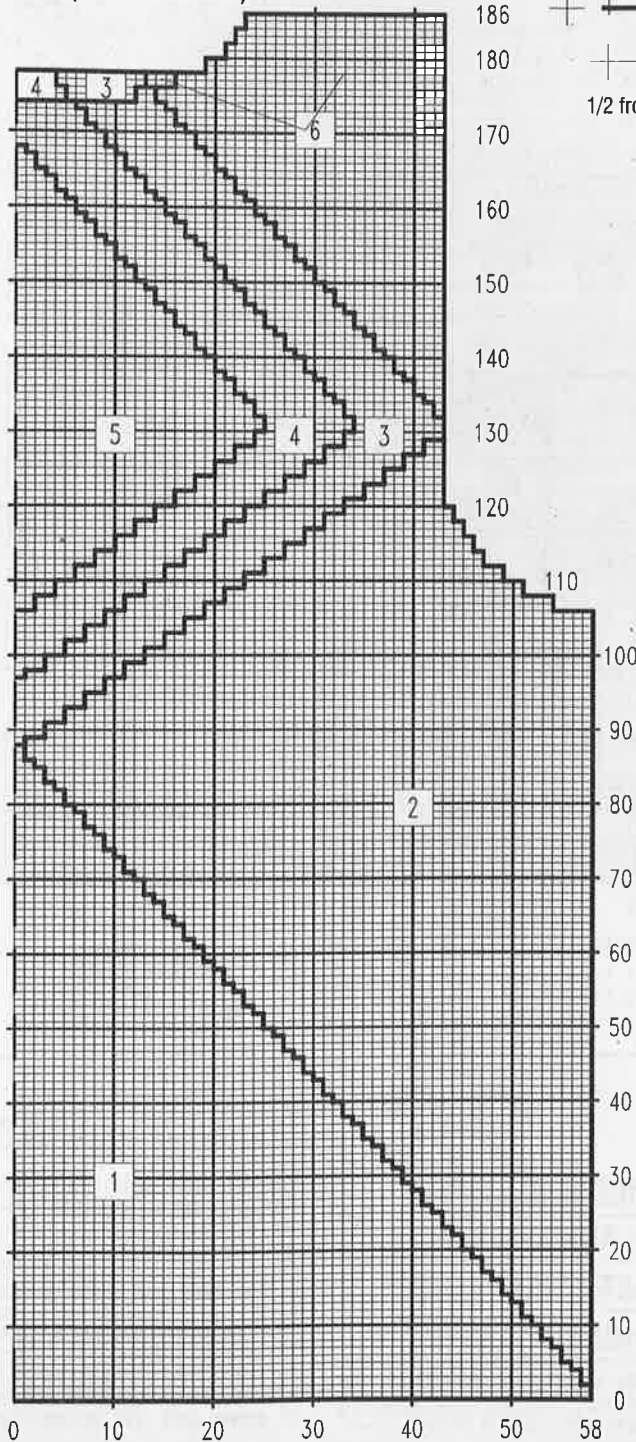

# MODEL 25

## SWEATER WITH COCKTAIL GLASS

Size: 10/12.

**Machines:** Suitable for chunky machines with intarsia carriage. We used a Brother KH 260.

**Material:** WSM "Soft" (100% cotton, 90m/50g) approx. 600g black and small amounts in purple and white. WSM "Roma" (55% acetate/viscose, 40% cotton, 5% polyamid, 105m/50g) approx. 150g purple and 100g each lilac and dk. blue. WSM "Pia" (50% linen, 50% viscose, 90m/50g) small amount in lt. green and orange. WSM "Jamaica" (60% viscose, 20% cotton, 15% polyacryl, 5% polyamid, 90m/50g) 50g each in green, gold and yellow. WSM "Carat" (100% polyester, 25m/50g) approx. 25g green. Small amount of red cotton and gold viscose. Small black beads.

The yarn is available by mailorder from E&S Strickstudio, Zinngiebergasse 9, 8015 Markt Schwaben, Germany. Send Eurocheque for DM 177.15 incl. postage.

3-31/2mm circular knitting needle for wells and neckband.

**Tension:** 20-21 sts and 29 rows = 10cm at TD approx. 2.

**Ribs:** K1, p1 rib on knitting needles.

**Intarsia:** Worked from chart as shown. Smaller areas may be swiss-darned.

**Arrows on diagrams** indicate direction of knitting.

**Back:** Cast on with yarn 100 sts and knit several rows. Set RC 000 and knit in black st st to RC 108. Mark both

cont. next page

sides for armholes. Knit to RC 186 and cast off.

**Front:** Cast on as for back. Set RC 000 and knit, following chart. Mark both edges for armholes at RC 108. Cast off at neck as shown on chart cast off rem. 25 sts at each side for shoulders at RC 186.

**Sleeves:** Cast on 50 sts with waste yarn and knit several rows. Set RC 000 and knit in black st st, incr. 1 st at each side on every 4th row 30 times = 110 sts. Cast off all sts at RC 124.

**Welts and cuffs:** Pick up sts from waste yarn and knit in rib, 10cm wide for front and back. 11cm wide for sleeves.

**Finishing:** Close one shoulder seam. Pick up approx. 110 sts around neckline and knit 3-4cm in rib. Cast off. Close other shoulder and neck band seam. If wished, turn neckband in half to outside and stitch down. Set in sleeves. Close rem. seams.

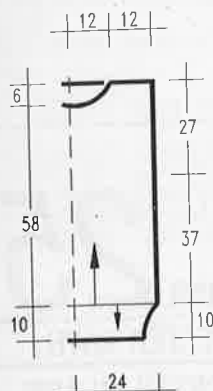

1/2 front and back

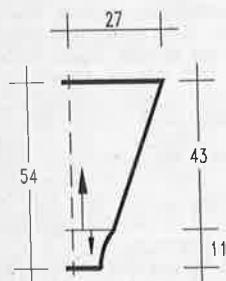

1/2 sleeve

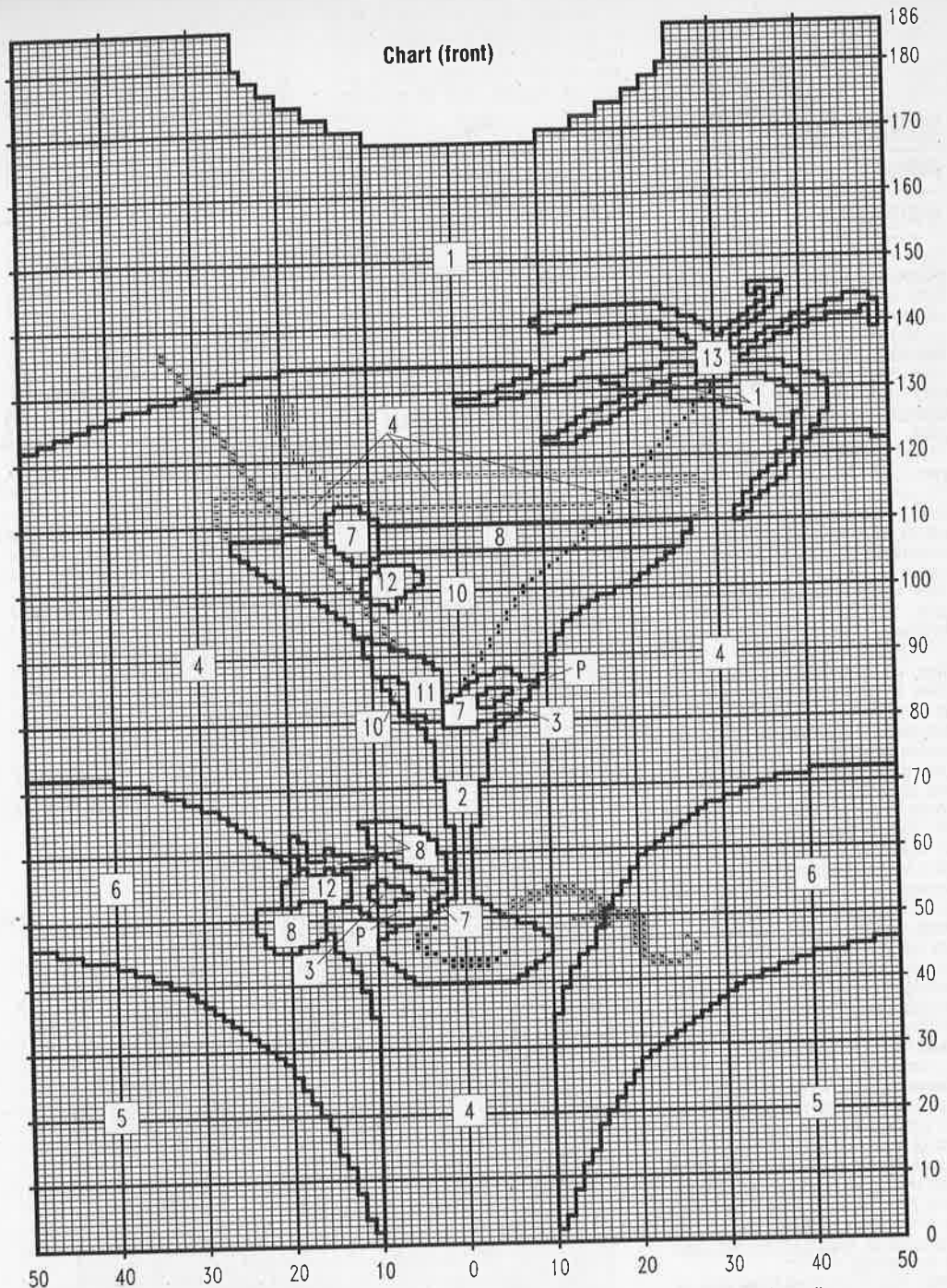

**Key:**

- |                 |                   |                       |                         |
|-----------------|-------------------|-----------------------|-------------------------|
| 1 = Soft black  | 4 = Roma purple   | X = Pia orange        | 11 = Jamaica yellow     |
| 2 = Soft purple | 5 = Roma lilac    | 8 = gold viscose      | 12 = red cotton         |
| 3 = Soft white  | 6 = Roma dk. blue | 9 = Jamaica green     | 13 = Carat green        |
|                 | 7 = Pia lt. green | ● = 10 = Jamaica gold | P = beads at random     |
|                 |                   |                       | 1 square = 1 st and 1 R |

# MODEL 26

## BLACK SWEATER WITH SILK FLOWER AND BUTTERFLY

**Size:** 8/10 (12/14). The instruction for the larger size are in brackets. One figure only applies to all sizes.

**Machines:** Suitable for chunky machines with intarsia carriage. We used a Brother KH 260.

**Material:** WSM "Soft" (100% cotton, 90m/50g) approx. 500(550)g in black and 50g lilac. WSM "Roma" (55% acetate/viscose, 40% cotton, 5% polyamid, 105m/50g) approx. 150g dk. blue, 100g each purple and lilac. WSM "Pia" (50% linen, 50 viscose, 90m/50g) approx. 50g each in lt. green and orange. WSM "Jamaica" (60% viscose, 20% cotton, 15% polyacryl, 5% polyamid, 90m/50g) approx. 50g each in green, gold and yellow. Small

amounts of viscose in gold, red and white.

For the welts WSM "City" (100% cotton, 125m/50g) approx. 100g black. 3 1/2mm knitting needles. Small beads as seeds on the fruit. One flower and one butterfly appliqué.

**Tension:** 20 sts and 27 rows = 10cm at TD approx. 2 knitted in Soft.

**Ribs:** K1, p1 rib by hand or on standard gauge machine.

**Intarsia:** Knitted from chart. The chart also shows neckline shapings.

**Arrows** on diagrams indicate direction of knitting.

**Front:** Cast on with waste yarn 100(110) sts and knit several rows. Set RC 000 and with main yarn knit, following the chart. At RC 97, mark both edge for armhole. At RC 158, shape neck by pushing needles to HP as given on chart. Knit each side separately. At RC 174, cast off rem. 28(33) sts for shoulder. Return N from HP to WP and knit 20 rows st st in Soft. Cast off loosely.

**Back:** Cast on and knit as for front, marking for armholes at RC 97. Knit to RC 170 and shape neck. Push to HP the centre 40 sts and all sts at side opposite to carriage. At neck edge push to HP on alt. rows 1 st twice. Cast off rem. 28(33) sts at RC 174. After knitting second side, knit neckband as on front.

**Sleeves:** Cast on with waste yarn 60 sts and knit several rows. Set RC 000 and knit in Soft and st st, incr. 1 st at each side on every 5th row 10 times and on every 4th row 17 times = 114 sts. At RC 120, cast off all sts loosely. **Welts:** Pick up sts from waste yarn at lower edge of back or front and knit 7cm in rib. Cast off.

**Cuffs:** Pick up sts from lower edge of sleeve and knit 1 row, reducing them to 46. Knit 7cm in rib and cast off.

**Finishing:** Sew on appliques. Embroider in stemstitch in black around the glass. Close shoulder and neckband seam. Fold neckband in half to inside and slipstitch in position. Set in sleeves between markers. Close rem. seams. Sew on beads.

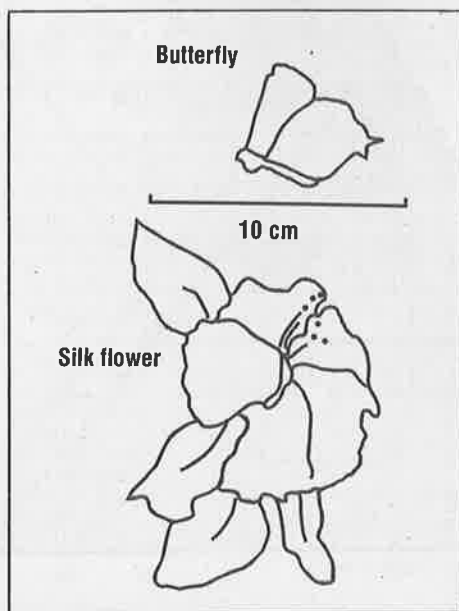
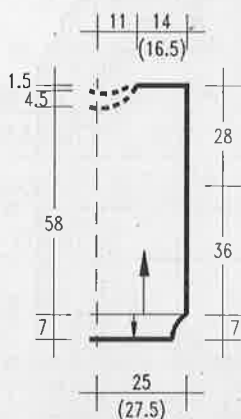
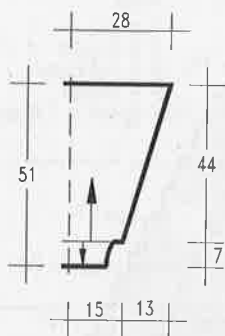
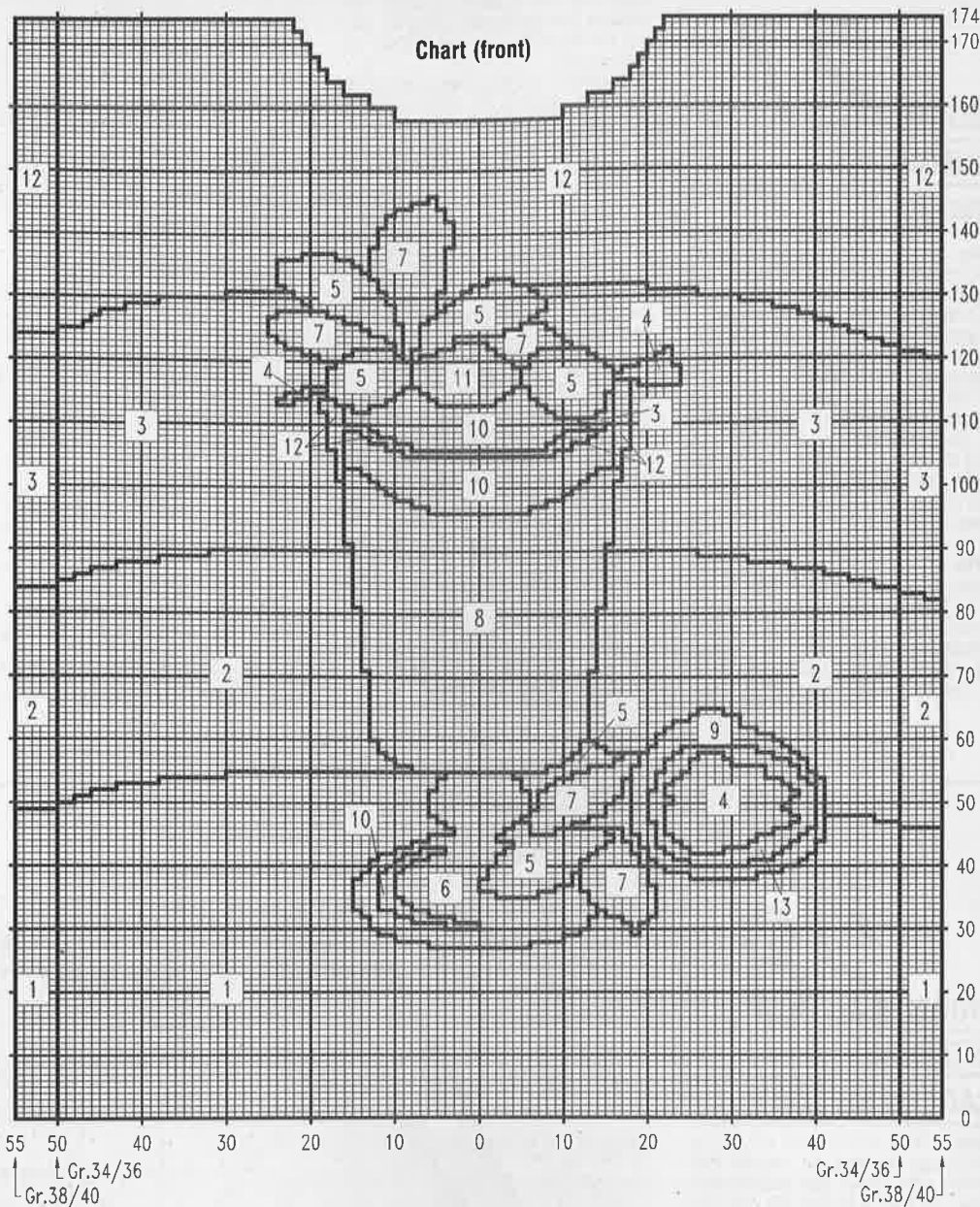

- Key:**
- 1 = Roma dk. blue
  - 2 = Roma purple
  - 3 = Roma lilac
  - 4 = Pia orange
  - 5 = Pia lt. green
  - 6 = Soft lilac
  - 7 = Jamaica green
  - 8 = Jamaica gold
  - 9 = Jamaica yellow
  - 10 = gold viscose
  - 11 = red viscose
  - 12 = Soft black
  - 13 = white viscose
- 1 square = 1 R and 1 st

# MODEL 27

## CHEQUERED SWEATER

**Size:** 12/14 (16/18). The instructions for the larger size are in brackets. One figure only applies to all sizes.

**Machine:** Suitable for standard gauge machines with ribber and intarsia carriage. We used a Brother KH 930.

**Material:** AUSTERMANN "Musical" (100% mercerised cotton, 125m/25g) approx. 300(350)g lt.olive, 200(250)g in pink, 100(150)g each in med.olive and dk.olive. "AngoraWolle" (70% Angora, 30% wool, 125m/50) approx. 75(100)g each in pink and lt.olive.

**Tension:** 26 sts and 33 rows = 10cm at TD 10.

**Ribs:** 1/1 rib at TD approx. 5. For the cable, transfer the centre 6 sts to the MB. Cable the 6 sts on every 8th row, always in the same direction.

**Chequered pattern:** Knitted in intarsia as given in the diagram. Each square is 29(31) sts wide and 27(30) rows

long. On the sleeves arrange the squares from the centre outwards, taking the extra sts into the colours as appropriate.

**Tucks:** When reaching the positions for the tucks, push all sts not required to HP. With K-carriage knit 10 rows in correct colour. Pick up loops from 1st row of tuck and place on needles. Knit 1 row st st.

Return the needles to correct position for intarsia.

**Arrows** on diagrams indicate direction of knitting.

**Back:** Cast on in waste yarn 145(155) sts and knit several rows. Set RC 000 and change to intarsia as on diagram. Knit to RC 135(150) and cast off.

**Front:** Knit as for back.

**Sleeves:** Cast on with waste yarn 84(90) sts and knit several rows. Set RC 000 and knit in lt.olive st st, increasing 1 st at each side on every 4th row 27(29) times. When RC shows 57, change to intarsia as in diagram and continuing the increases as before. At RC 111(117) cast off all 138(148) sts.

**Welts:** Pick up sts from waste yarn at lower edges of back or front. Decr. evenly across the row, hang on 126(136) N. Knit with lt.olive 1 row st st. Leaving the centre 6 sts on MB for the cable, transfer the others for 1/1 rib. Knit 44 rows and cast off.

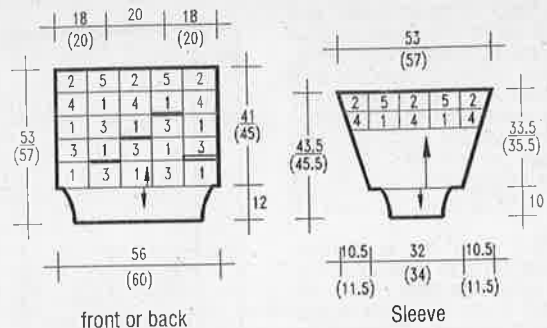

### Key:

- 1 = rose cotton
- 2 = rose Angora
- 3 = med.olive cotton
- 4 = lt.olive Angora

- 5 = dk.olive cotton
- 6 = lt.olive cotton
- = Tuck in Angora rose
- = Tuck in lt.olive Angora

**Cuffs:** Hang sts from lower edge of sleeves on 66(70) N and knit 36 rows rib as described above.

**Back yoke:** Cast on 35 sts in 1/1 rib and knit 154 rows in lt.olive.

**Front yoke:** Cast on and knit as above, knitting two pieces each 200 rows long.

**Finishing:** Sew the yokes to back and front. On front, leave sufficient open to

knit the two pieces. Close shoulder seams except for 20cm in centre. Set in sleeves, matching the squares. Close side and sleeve seams.

# MODEL 28

## INTARSIA RAGLAN SWEATER

**Size:** 12 - 16.

**Machines:** Suitable for chunky machines with ribber and intarsia carriage. We used a Brother KH 260.

**Material:** KKK "Clip" (100% cotton, 166m/100g) approx. 400g stone grey. AUSTERMANN "Goldregen" (58% viscose, 37% polyacryl, 5% met.polyester, 75m/50g) approx. 200g grey-pink-flecked. LANA LAMBERTI "Regatta" (50% cotton, 50% viscose, 100m/50g) approx. 150g black. GGH "Angora" (70% Angora, 30% Lambswool, 33m/10g) approx. 120g lilac.

The yarn is available by mailorder from WOLLSTUDIO Jutta Hinrichs, Wormser Str. 5, 6550 Bad Kreuznach, Germany. Send Eurocheque for DM 213.50 incl. postage.

**Tension:** 19-20 sts and 30 rows = 10cm at TD 0\*\*.

**Ribs:** 1/1 rib at TD 0.

**Intarsia:** Knitted from the relevant charts, which also show the increases and decreases.

**Arrows** on diagrams indicate direction of knitting.

**Back:** Cast on with waste yarn 114 sts and knit several rows. RC 000 and work from chart 1. At RC 174, cast off rem. 50 sts.

**Front:** Work as for back to RC 158. Cast off sts as marked on chart.

Chart 1 (front and back)

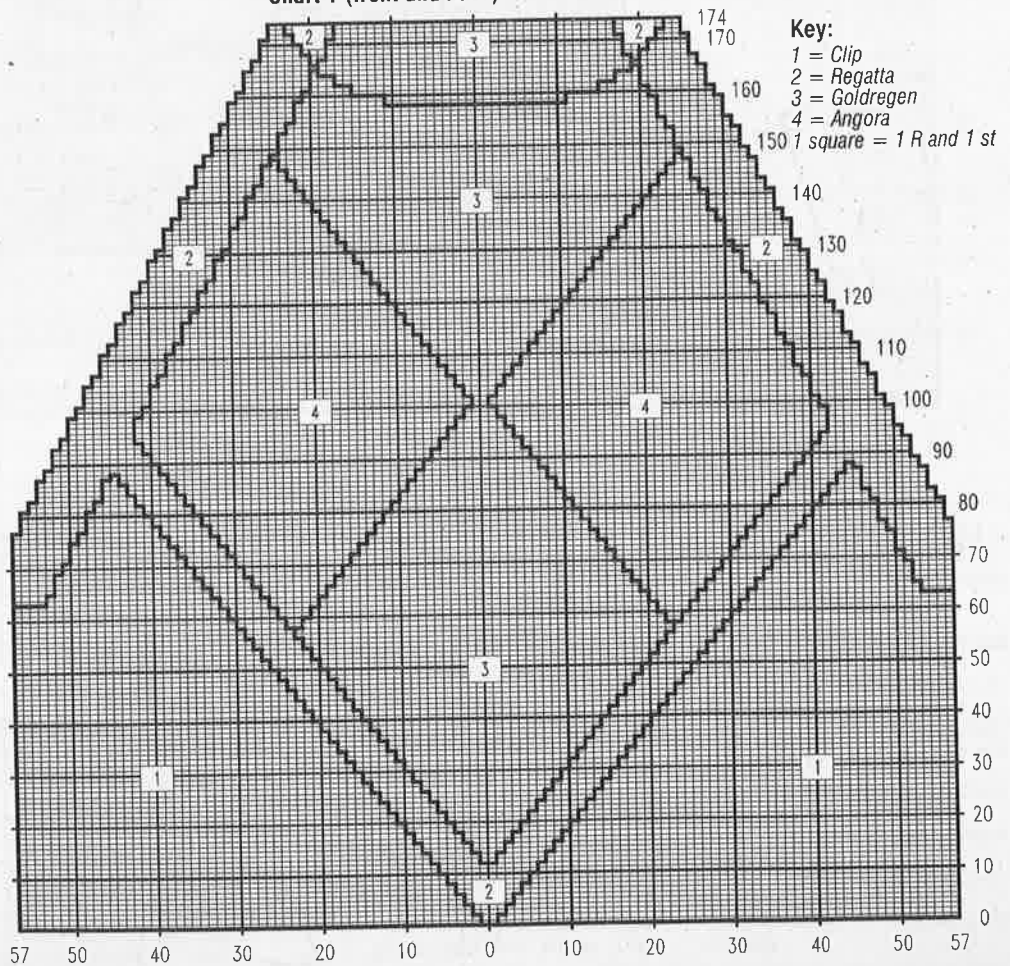



**Sleeves:** Cast on with waste yarn 74 sts and knit several rows. Set RC 000 and work from chart 2, increasing as shown to RC 105. Shape top as shown.

**Welts:** Push 98 needles to WP on MB. Hang sts from lower edge of back or front, decreasing evenly across the row. Knit 1 row st st. Transfer sts for rib and knit 30 rows. Cast off.

**Cuffs:** Push 50 needles to WP on MB. Hang sts from lower edge of sleeves on needles, decreasing evenly across the row. Knit 1 row st st. Transfer for rib and knit 30 rows. Cast off.

**Neckband:** Set ribber to H-position. Push N 36-0-36 on each bed to WP. Cast on in grey and knit at TD 4 in every-needle rib for 38 rows. Release work from machine on waste yarn.

**Finishing:** Close raglan seams. Close neckband to circle. Pin to neckline and sew on from outside. Fold in half to inside and stitch in position. Close rem. seams.

Chart 2 (sleeve)

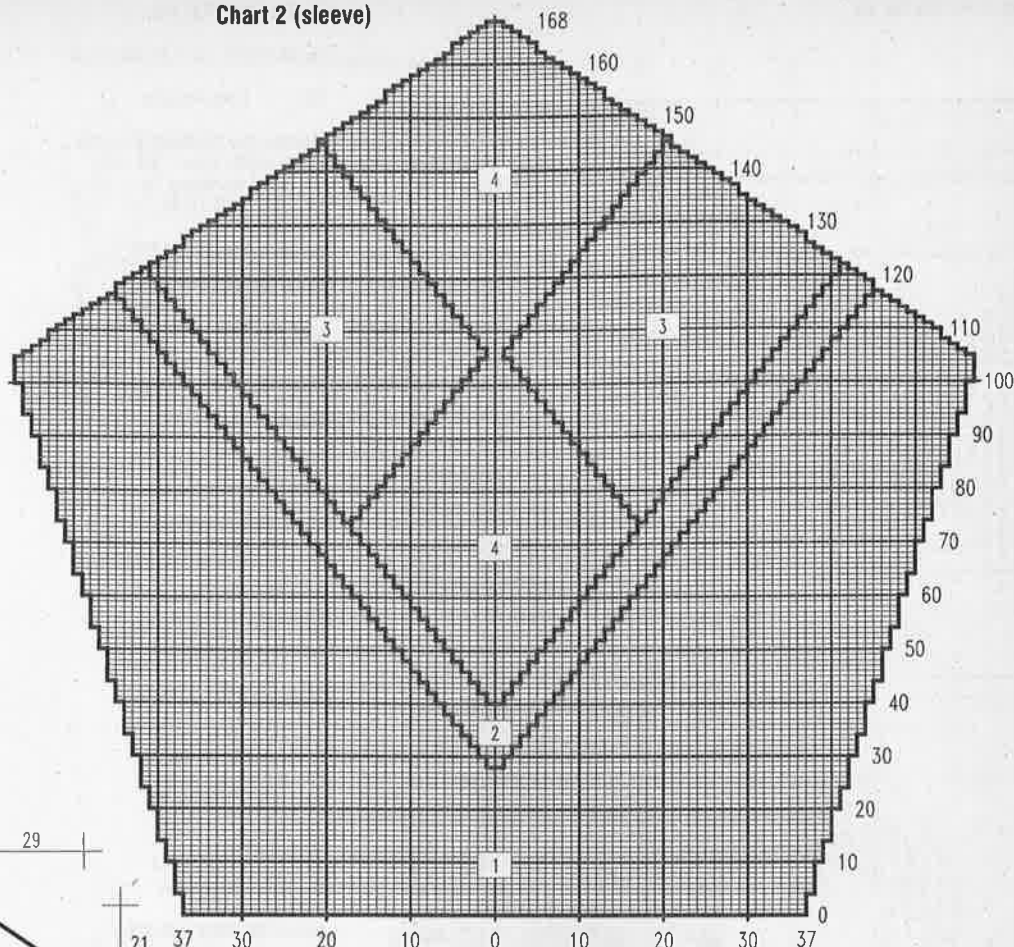

**Key:**  
1 = Clip  
2 = Regatta  
3 = Goldregen  
4 = Angora  
1 square = 1 R and 1 st

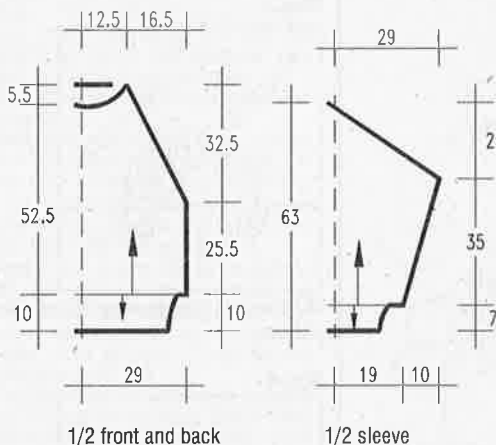

**Sleeves:** Close shoulder seams except for 24cm in centre. Pick up 160 sts between markers and with wrong side out, hang on needles. Set RC 000 and knit in st st, decreasing 1 st at each side on every 4th row 30 times = 100 sts. AT THE SAME TIME, make a cable on centre 6 sts as on main part. Drop 1 st either side from time to time and latch up to form a purl stitch. At RC 124, take work off machine and re-hang sts on 58 needles, decr. evenly

across the row. Knit 30 rows rib and cast off.  
**Finishing:** Close side and sleeve seams.

cont. next page

# MODEL 29

## MAIZE YELLOW

### GARTER STITCH

### SWEATER

**Size:** 12 - 16.  
**Machines:** Suitable for electronic standard gauge machines with more than 60-stitch patterning and garter carriage. We used a Brother KH 940.  
**Material:** WOLLSERVICE "Cablé 30" (100% mercerised cotton, 140m/50g) approx. 550g maize yellow.  
The yarn is available by mailorder from Christle Haegle, Burg-Windeck-Str. 4b, 7580 Bühl/Baden, Germany. Send

Eurocheque for DM 74.50 incl. postage.

**Tension:** 29-30 sts and 32 rows = 10cm at TD approx. 10.

**Ribs:** 2/2 rib at TD approx. 5 with garter carriage. Stitch World Pattern No. 534.

**Garter stitch pattern:** Program machine or mark mylar sheet from chart. The pattern extends over 169 sts and 80 rows. The 6 sts in the areas marked Z, are cabled every 8th row, always in the same direction. Set switch 5 UP to knit the pattern from top to bottom after row 80.

**Arrows** on diagrams indicate direction of knitting.

**Back:** cast on 150 sts and knit 30 rows rib. Set RC 000. Increase to 169 sts evenly across the row. Knit in pattern to RC 80 and mark both side edges for armholes. Knit to RC 157. Program Stitch World Pattern No. 537 and knit 10 rows. Cast off.

**Front:** Knit as for back.

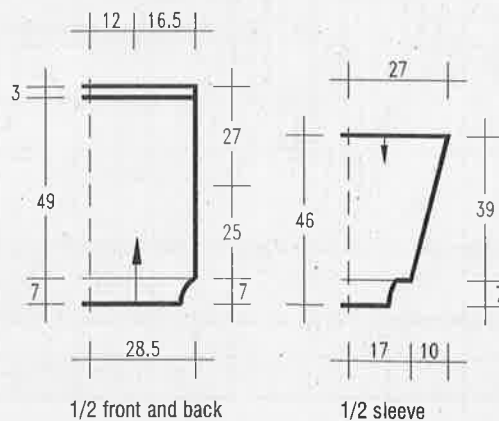
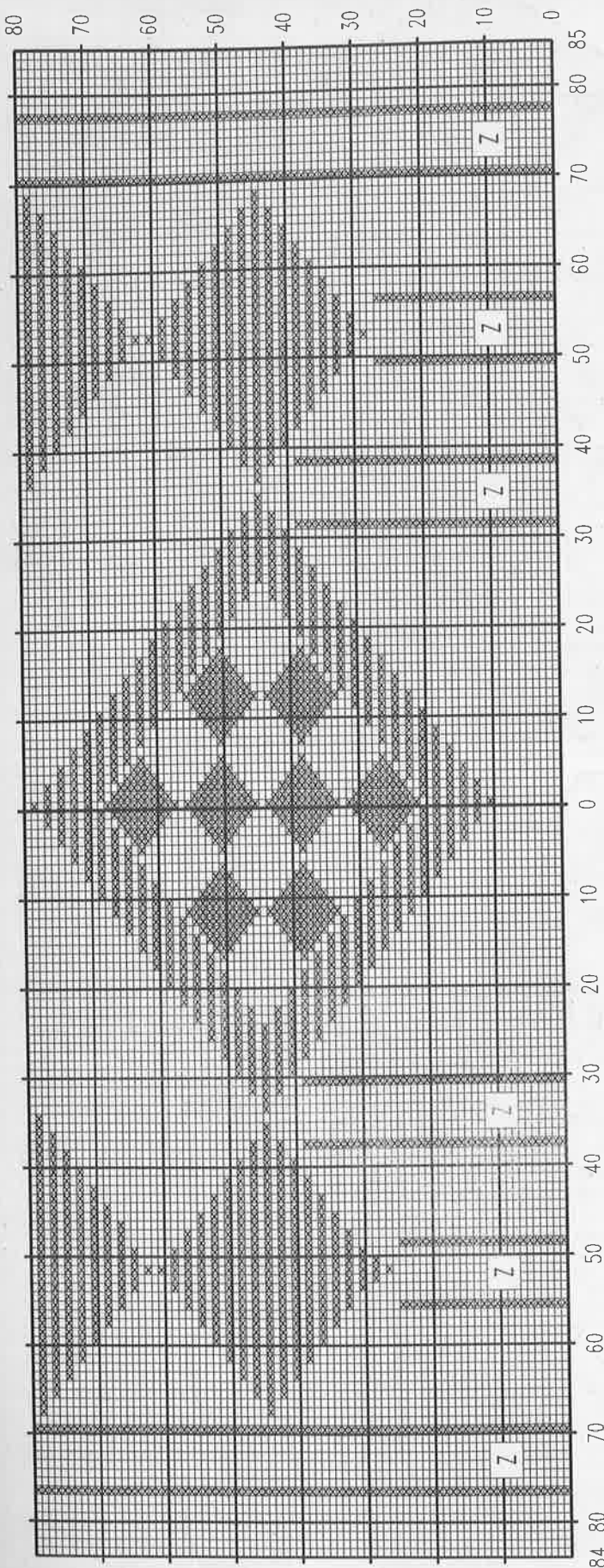

Chart for Model 29



**YARN SUPPLIERS**

**Austermann** via Jutta Hinrichs

**GGH** via Jutta Hinrichs

**Hamburger Wollfabrik GmbH**  
Brandshofer Deich 46 - 48  
D - 2000 Hamburg 28  
Tel.: 040 / 78 78 45

**Junghans Wollversand**  
Gut-Dämme-Straße 4  
5100 Aachen

**KKK** via Jutta Hinrichs

**Lana Lamberti** via Jutta Hinrichs

**Mode-Laine** via Jutta Hinrichs

**Phildar UK Ltd.**  
2 Peary Street  
Rochdale Road  
Manchester M60 4BW  
Tel.: 061- 8343371

**Schachenmayr**  
Postfach 1160  
D - 7335 Salach  
Tel.: 07162 / 140

**Stahl** via Jutta Hinrichs

**Atelier Gilla Wilmes**  
Düsselthaler Straße 1  
D - 4000 Düsseldorf 1  
Tel.: 0211 / 36 58 85

**Woll-Service**  
Im Gewerbegebiet 11  
D - 8069 Geisenfeld

**WSM-Westima / Wolltex**  
Rheinstraße 28  
D - 6100 Darmstadt

**All yarns are also obtainable from:**

**Wollstudio Jutta Hinrichs**  
Wormser Str. 5  
6550 Bad Kreuznach  
W.- Germany  
Tel.: 0671 / 42625

**KNITTING MACHINE MANUFACTURERS**

**Brother**  
Jones Sewing Machines Ltd.  
Manchester Office  
Shepley Street  
Manchester M34 5JD  
Tel.: 3300111

**Empisal**  
Knitmaster  
39-45 Cowleaze Road  
Kingston-Upon-Thames  
Surrey KT2 2DT  
Tel.: 01 546 2444

**Phildar UK Ltd.**  
2 Peary Street  
Rochdale Road  
Manchester M60 4BW  
Tel.: 061- 8343371

**Singer über**  
Mr. K. Dickinson  
EuropeanHome Products  
John Scott House  
Market Street  
Bracknell / Berkshire RG12 2JB  
Tel.: 0344 41 25 12

**Crochet button loops:**

**Step 1:**

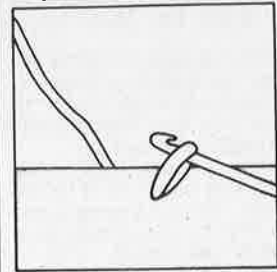

Insert the crochet hook where required and draw a chain loop through.

**Step 2:**

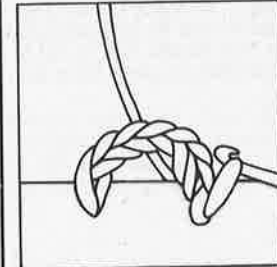

Work as many chains as are required to make the loop fit the button and fasten in position with 1 slip stitch.

**Step 3:**

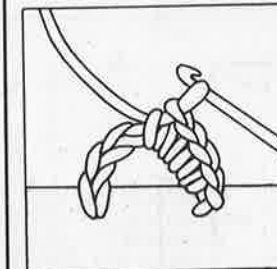

Work double crochet along the loop of chains.

**Step 4:**

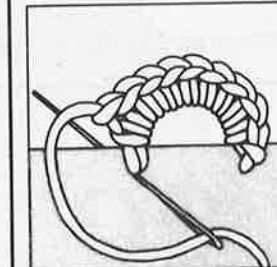

Draw yarn through to wrong side of work

**Step 6:**

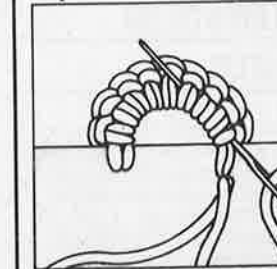

and sew through the dc sts of loop and fasten off. Fasten starting thread the same.

# MODEL 30

SOFT WHITE

SWEATER

WITH EMBROIDERY

**Size:** 10 - 14. Can only be knitted larger on machines with more than 114 needles.

**Machines:** Suitable for chunky machines with 9mm or 7mm gauge. We used a Brother KH 260.

**Material:** MODE-LAINE "Farsa" (60% cotton, 40% viscose, 90m/50g) approx. 800g soft white.

The yarn is available by mailorder from STRICKATELIER Weber, Donnenstr. 11, 5249 Eitzbach, Germany. Send Eurocheque for DM 115.20 incl. postage. You will also need small amounts of Angora in yellow and rust. Silk in rust, pink and grey and various shades of green, blue and brown. 3 1/2mm crochet hook. 3 1/2mm circular knitting needle.

**Tension:** 23 sts and 29 rows = 10cm at TD 0 with close-knit bar.

**Ribs:** Knitted by hand in cable pattern:  
Row 1: Edge stitch, \* pl, k2 crossed (knit 2nd st in front of 1st, then 1st stitch), pl. Row 2: Knit all sts as they appear. Repeat these two rows.

**Arrows** on diagrams indicate direction of knitting.

**Back:** With waste yarn cast on 114 sts and knit several rows. Set RC 000 and knit in st st to RC 88. Shape armholes. Cast off at each side on alt. rows 4 sts once, 3 sts once and 1 st twice = 92 sts. Knit to RC 160 and cast off.

**Front:** Cast on and knit as for back to RC 110. Divide work for V-neck and knit each side separately. At inner edge, decrease 1 st on alt. rows 23 times. Cast off rem. 23 sts for the shoulder at RC 160.

**Sleeves:** Cast on with waste yarn 98 sts and knit several rows. Set RC 000 and continue in st st. Increase 1 st at each side on every 10th row 8 times = 114 sts. At RC 86, shape sleeve top. Cast off at each side on alt. rows 3 sts once, 2 sts once and 1 st 4 times. Decrease 1 st at each side on every 4th row 14 times = 68 sts. Cast at RC 154.

**Welts:** Pick up sts from lower edge of front or back on knitting needles and reduce them to 106 sts. Knit 10cm in cabled ribs.

**Cuffs:** Pick up sts from lower edge of sleeves on knitting needles, reducing them to 54. Knit 10cm in cabled ribs and cast off.

**Embroidery:** Have the diagram enlarged to correct size. Lay pattern on garment and with sewing cotton, tack through the outline of the larger flowers. Embroider these first and then fill the spaces with bullion switch.

**Finishing:** Close shoulder seams. Crochet around armholes with 1 row crabstitch. Set in sleeves, gathering the top to fit. Close rem seams. For the neck trim, knit 2 strips over 8 sts approx. 80-90cm long. Twist them together and sew to neckline, unravelling the surplus.

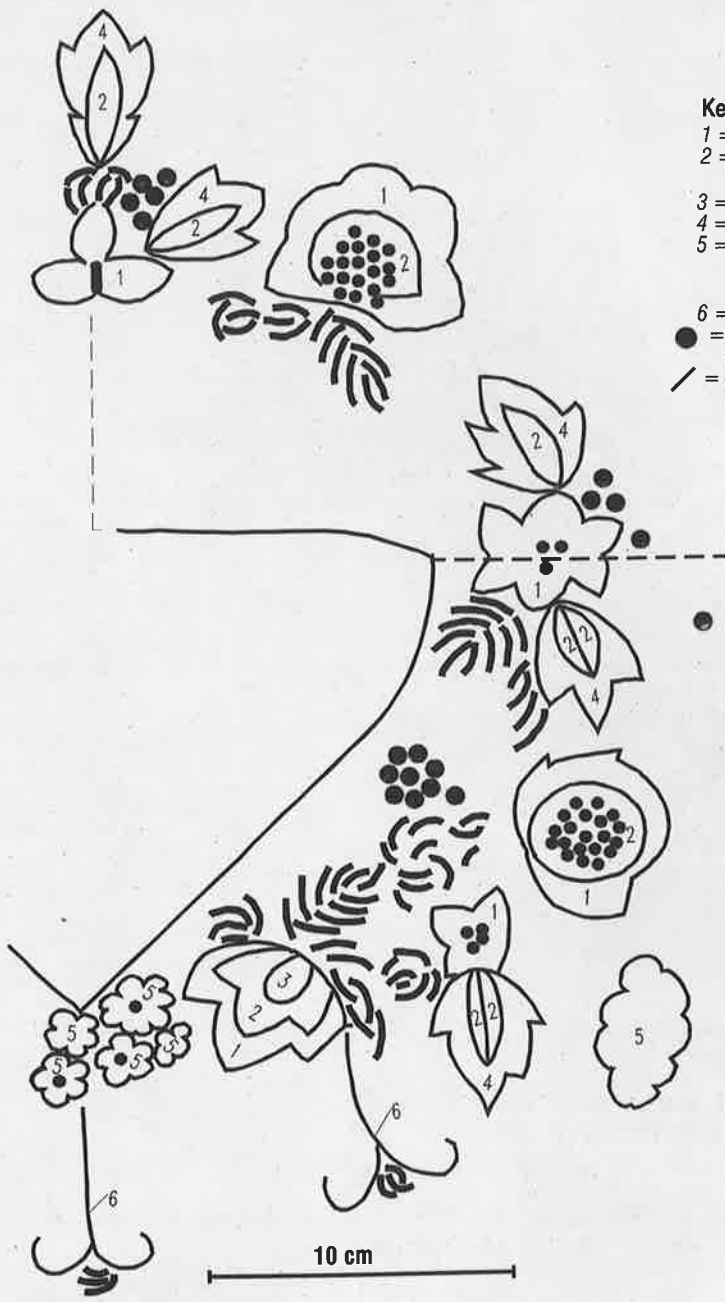

**Key to embroidery:**

- 1 = yellow Angora satin stitch
- 2 = rust Angora or silk satin stitch
- 3 = gold Lurex satin stitch
- 4 = Brown silk satin stitch
- 5 = bullion stitch arranged in flower shape in various colours
- 6 = brown silk stem stitch
- = french knots various colours
- / = bullion stitch various colours

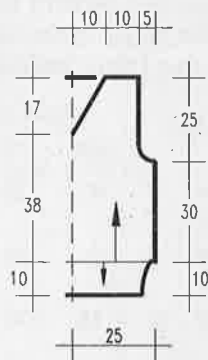
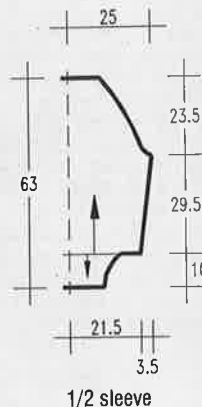

**Tip:**  
If your next ball of yarn is a different dye number, knit 10 rows using the two balls alternately. In this way, the two shades will blend and the difference is less noticeable.

# TIPS - TIPS - TIPS - TIPS - TIPS - TIPS

## Design your sleeves on squared paper!

Today we will explain how to work out shapings on sleeves using the given measurements and a tension swatch.

1. Obtain some squared paper. If the markings are too small, have an enlargement made. This works better, if the original is printed in red.
2. Knit and measure a tension swatch. For our example, we will take 29 sts and 36 rows = 10cm.
3. To convert to rows and stitches from the above, divide as follows:

$$10\text{cm} = 29 \text{ sts.}$$

$$1\text{cm} = 29 : 10 = 2.9 \text{ sts}$$

$$14.4\text{cm} = 14.5 \times 2.9 =$$

$$42.05 = 42 \text{ sts}$$

The same technique is used for the rows. Count 1 square for each stitch or row and draw the shape on the paper. Connect the lines and then draw the shapings. You will now be able to read off the shaping from the chart. You can also use the method to arrange patterns for intarsia. Squared paper may distort the pattern slightly, as the stitches are not square, however it is of little consequence.

4. It helps to mark the pattern along the outside edges on every 10th row to facilitate counting. It will also help you to co-ordinate the figures on the row counter with the pattern.

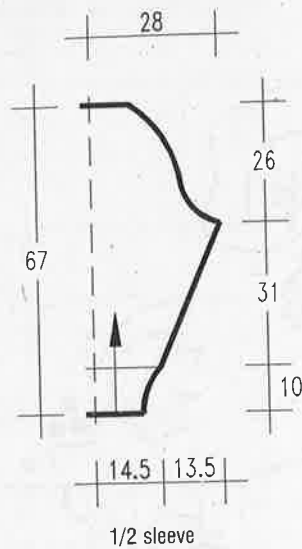
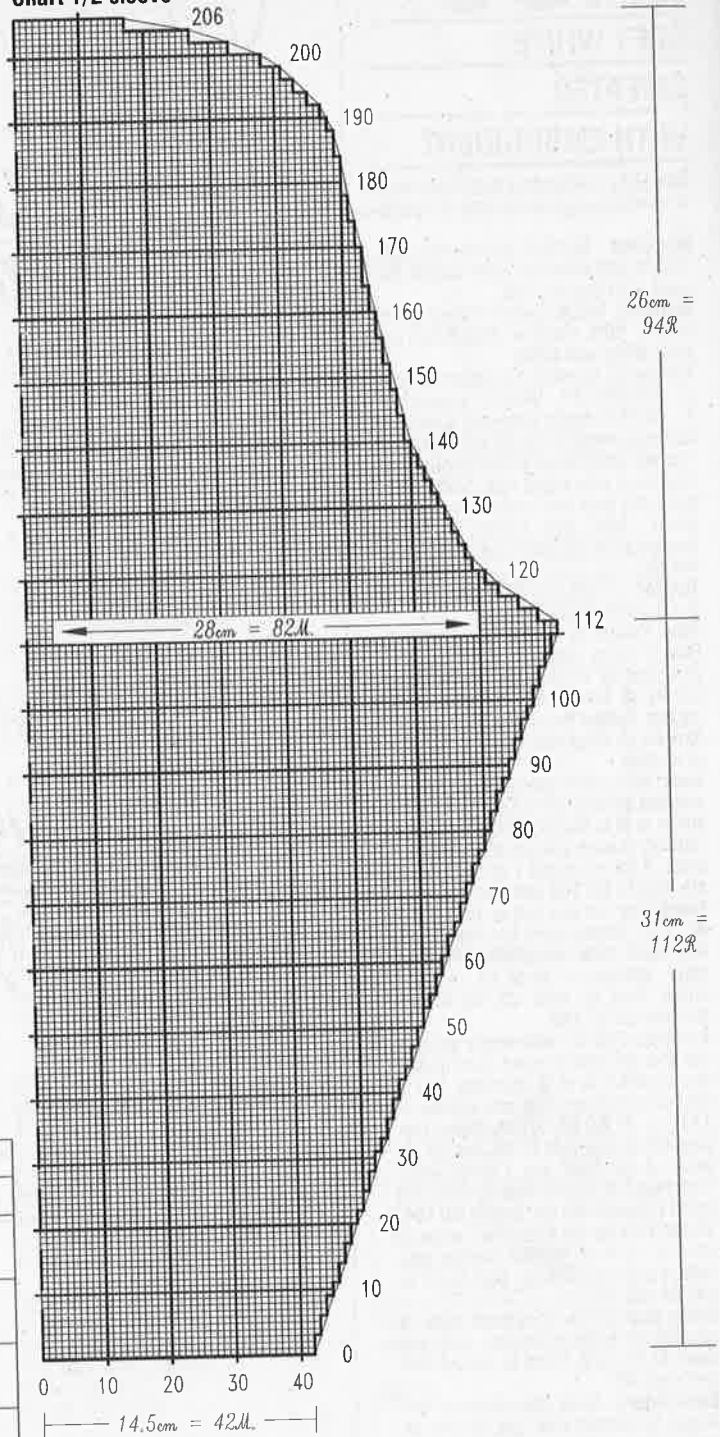

Chart 1/2 sleeve



## Size chart

Before starting to knit, please compare your measurements with those given in the table below.

| Size | Bust |     | Waist  |     | Hips   |     |        |
|------|------|-----|--------|-----|--------|-----|--------|
|      | cm   | ins | cm     | ins | cm     | ins |        |
| 34   | 8    | 82  | 32 1/2 | 62  | 24 1/2 | 88  | 34 1/2 |
| 36   | 10   | 84  | 33     | 64  | 25 1/2 | 90  | 35 1/2 |
| 38   | 12   | 88  | 34 1/2 | 68  | 26 3/4 | 94  | 37     |
| 40   | 14   | 92  | 36 1/2 | 72  | 28 1/4 | 98  | 38 1/2 |
| 42   | 16   | 96  | 37 3/4 | 77  | 30 1/4 | 102 | 40 1/4 |
| 44   | 18   | 100 | 39 1/2 | 82  | 32 1/2 | 106 | 41 3/4 |
| 46   | 20   | 104 | 41     | 87  | 34 3/4 | 110 | 43 1/4 |

Model 15, Size 12/14

Stay absolutely in fashion! Special effects and beautiful colours in luxurious yarns can not be ignored.

**DREAMS**

**PATTERNS FOR ROMANTIC**

Model 16, Size 10/12



Left lace in Angora with cotton for effect. On the right fantastic flowers create a focal point.



Model 17, Size 10/12 (14/16)

**EXCITING**

**FASCINATING AND**

Model 18, Size 12/14 (14/18)



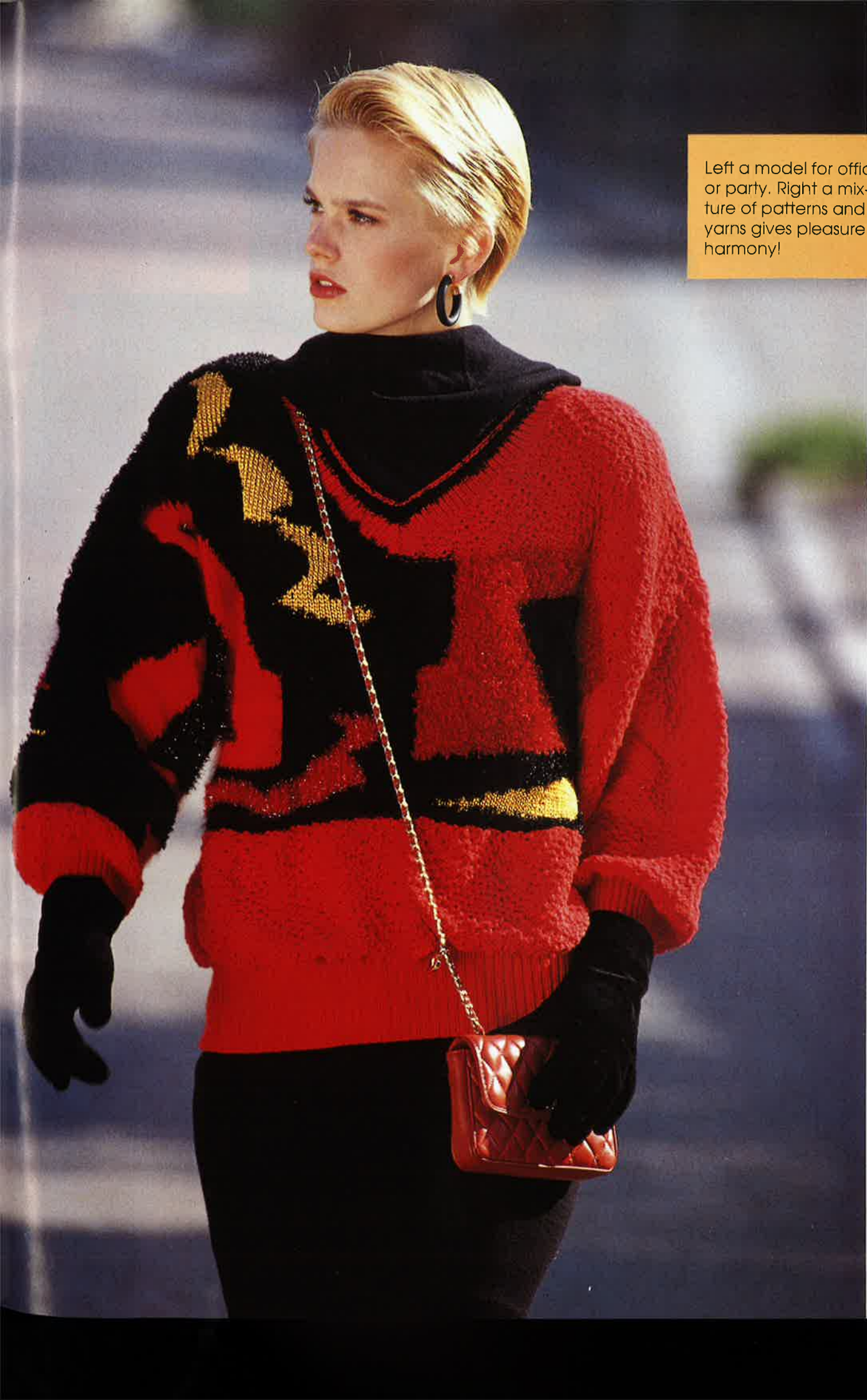

Left a model for office or party. Right a mixture of patterns and yarns gives pleasure in harmony!



Model 19, Size 12 - 16



Cyclamen, turquoise, black and white skillfully arranged to create something special. In short, a sweater to feel good in.

Model 21,  
Size 12/14 (16/18)



IN THE LATEST FASHION

Models with individual variations of geometric patterns to show the good taste of the wearer.

STITCHES

Model 22, Size 12/14 (16/18)





Model 23, Size 10/12 (14/16)

**ALWAYS WEARABLE!**

**DECEPTIVELY SIMPLE -**

On the left, a simple poloneck sweater enhanced by the colour and easy to knit. On the right, delicate pink with a small pattern that is also easy to knit.





**SUMMER**

**FRUIT COCKTAILS - NOT ONLY FOR**

Model 26, Size 8/10 (12/14)

Matching yarns and colours for the very different designs. Ideal for mothers and daughters.







# SQUARES AND DIAMONDS IN GOOD TASTE

Aces are trumps! Clear strong lines combined with soft and textured yarns means high class fashion. Creations for more than on season.



Model 28, Size 12 - 16

Model 27, Size 10/12 (14/16)



WHAT FUN

YELLOW ALL OVER OR VERY SPARINGLY,

Knit - purl patterns with cables are always effective, especially in cotton. Embroidery on lovely silk looks very elegant.

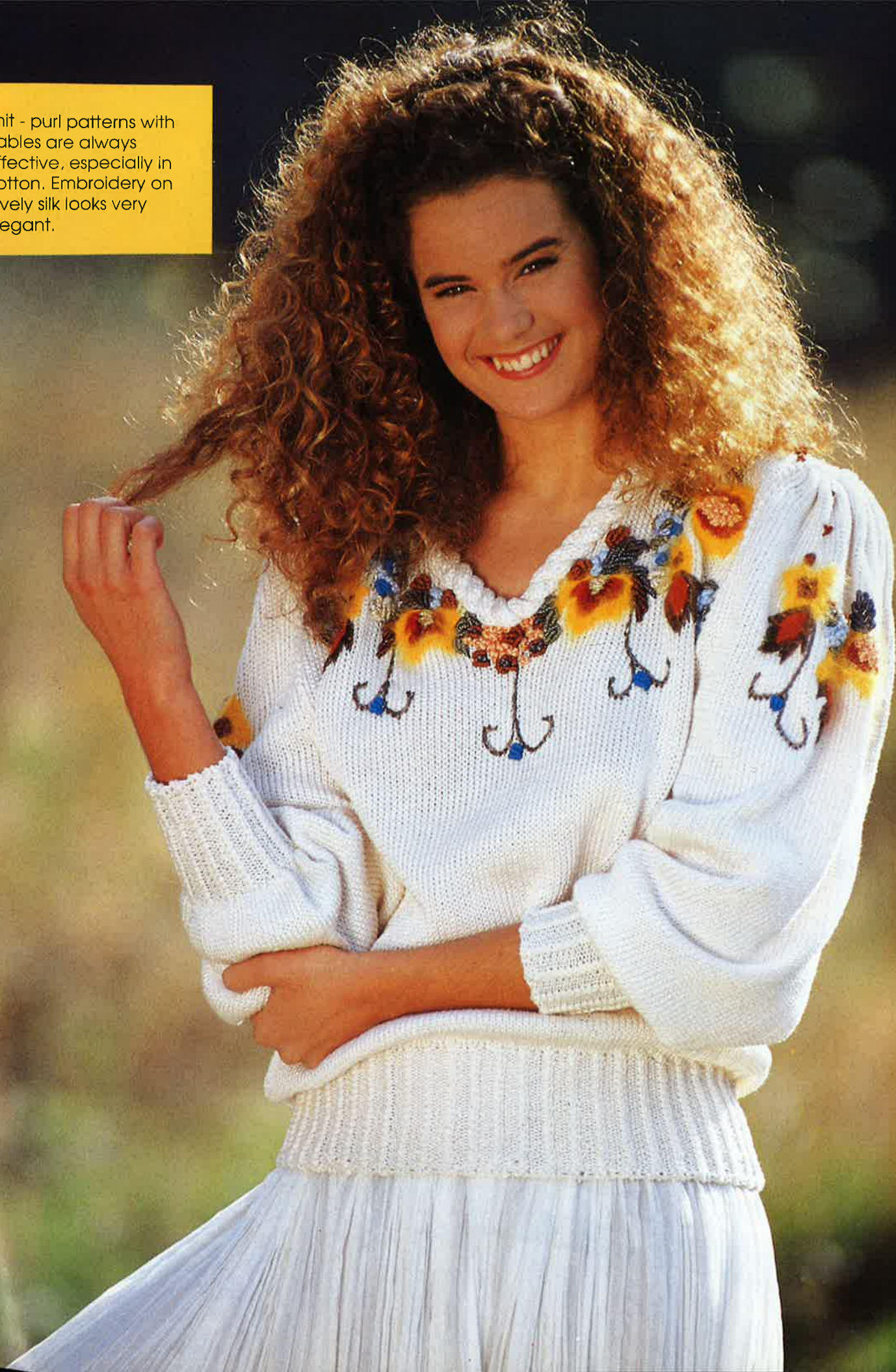

On sale at all  
newsagents!

