

stitchin' time

No.44

60p





Contents

Editorial:

Jones + Brother,
J & B House,
869, High Road,
Finchley,
London N12 8QW.

Subscription administration:

Shepley Street,
Guide Bridge,
Audenshaw,
Manchester M34 5JD.

Focus on Knitting	3 - 4
Man's woven battledress	5 - 6
Long nightdress	7
Blouse with woven lace sleeves and bolero	8 - 10
Honeycomb sweater	11
Lady's blouson with frilly neckline	12 - 13
Batwing cardigan	14 - 15
Lady's lace dress with long sleeves	16 - 17
Soft lacy suit	18 - 19
Lady's lace suit	20 - 21
Lacy shetland look	22
Sailor top	23
Gold evening dress	24 - 25
Home furnishing	26 - 27
Boy's fairisle sweater	28 - 29
Girl's shirred dress	30
Lace waistcoat	31 - 32
Boy's chunky sweater	33
Lady's Add-to-set	34 - 35

Broadly Speaking

We have concentrated on fashion garments in this issue including the blouson style and lacy look. On page 18 one of our designers has combined the two in a beautiful lacy blouson suit and on page 14 there is a lovely lacy batwing cardigan. For our Add to Set this month we have designed a polo necked jumper in the Hayfield Machine Knit to add to the dress, skirt and waistcoat and V-necked fairisle jumper.

We have two new features from Susan Nutbeam starting in Stitchin Time. In this issue 'Home Furnishing' begins with Susan telling you how she has knitted most of her furnishings and giving us patterns for a huge cushion and lace lampshade. This feature will continue throughout the year and in the next issue Susan will give you the pattern for a rug. Also starting in the next issue will be a 'Cut and sew' feature with different garments in each issue together with hints on how to knit in this way.

As you all can imagine it is not easy to photograph our garments during the winter months. Sandersons have very kindly let us use their interior design showrooms in the West End of London for our background in some of the photographs in this issue.

I hope some of you have managed to get along to either the Knitsew Exhibition or the Ideal Home Exhibition to see our knitting machine stand. At both these exhibitions we featured 3 new machines; the KH710 which updates the 588, the KH120 which is a push button machine especially for fine gauge yarns and KH840 which is an update of the 830. If you would like some more information on these machines please contact us or our knitting department in Manchester.

Finally we have had a great number of requests from our knitters for pattern books for the KH800. If you are interested please look at page 4 where you will see an exciting offer for these books.



FOCUS ON KNITTING



Pingouin have sent to us 26 new patterns using their iceberg, type shetland, nauge, cythere, sport, pasquinade, monsieur pingouin, poudreuse, caline and la houle yarns. We have illustrated 3 of the patterns here.

Patons have brought out 5 new patterns for all the family featuring their Trident and Pennant crepe yarns. If you have any difficulty in obtaining these patterns please let us know and we will be able to send them to you.

In the last issue we told you about Mailyarns. They have now introduced a new 2ply botany on cone called Fynwul. It is 100% pure new wool on 200g cones. It covers 12 feminine colours at a price of £2.70 per cone (1 - 3 cones) and £2.50 per cone (4 cones and over). Mailyarns believe that Fynwul will help to fill the void for a quality 2ply yarn. Free samples are available on receipt of SAE from Mailyarns Ltd (Dept J), 38, High Street, Syston, Leicester LE7 8GP.

We have details on 4 clubs this month ranging from West Bromwich to Callington in Cornwall.

Mrs. M. Dunton has telephoned us about her knitting club in Beaconsfield. If you have been looking for a club in that area, her address is 16,

Holtspur Top Lane, Beaconsfield, Bucks. For more information Mrs. Dunton's telephone number is Beaconsfield 5848.

If Bexleyheath is your area then Mrs. Griggs will be able to help you. She has just formed a club called Vale Crafts which meets once a month at the Welling Library Hall No. 3. They are primarily a machine knitters club, but they would like to introduce new crafts as well. Their members are able to sell their knitwear and make a little bit of pocket money. In the Spring they are helping to organise outings to mills and to the industrial museum in Bradford. This certainly sounds like an active club and if you are interested please contact Mrs. Griggs at 80, Erith Road, Bexleyheath, Kent.

For the knitting club in West Bromwich you will need to get in touch with Mrs. M. Langley. She runs a club with 40 members which meets once a week. She has also recently opened a shop, with her husband, selling yarn. Her address is Muriels Knitting Centre, 8, Arcadia, West Bromwich, West Midlands.

The last club this month is in Cornwall. Mrs. Iris Cox of Na-Harrow, Higherland, Stoke Climsland, Callington has

a club called the Delaware Machine Knitting Club. They meet the first Tuesday of every month at 7.30 at the Mission Hall, St. Ann's Chapel near Gunnislake. Mrs. Cox can be reached on Stoke Climsland 595 or Mrs. Yvonne Barstow on Gunnislake 832 381 will be able to help you.

The mid Norfolk Machine Knitting Club are holding their next Fashion Show on April 19th in the Assembly Rooms at Swaffham. Christine Webber of Anglia Television is opening the Fashion Show and they are also having a surprise guest which they can't publicise at the moment! Their last show was an overwhelming success and the proceeds went to the charity organisation MIND in Swaffham. The proceeds for the next show will be handed to the Swaffham and District Doctors' Radio Communications Service. The club has over 70 members, some of whom are knitting original designs for the occasion. If you are interested and want some more information, I am sure that Mrs. Norma Mingaye will be delighted to hear from you. Her address is 20 All Saints Way, Beechamwell, Swaffham, Norfolk PE37 8BU.

You will have noticed that some of the diagrams relating to shapes have been measured in centimetres. We have listed below metric comparisons for measurements in feet and inches for your guidance.

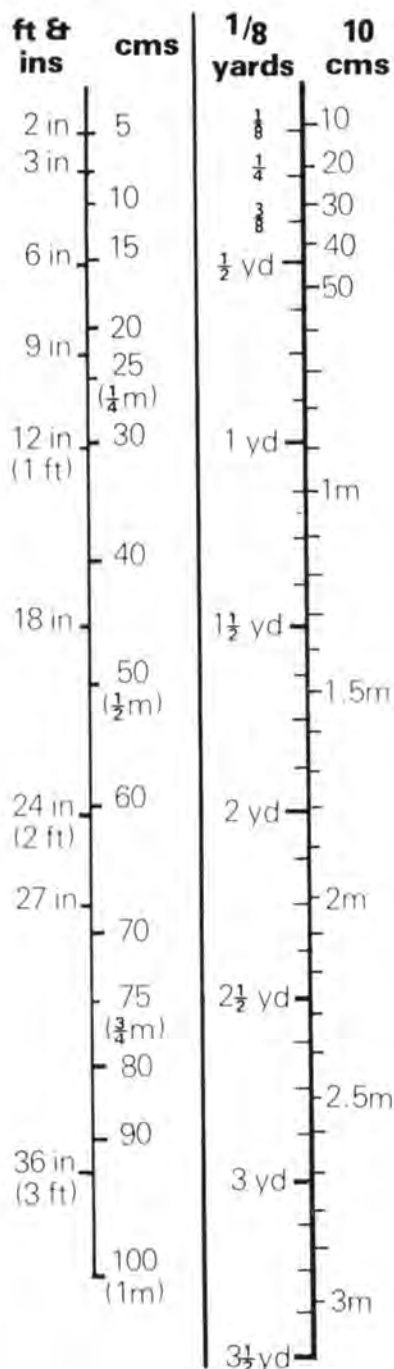

Approximately:
 1 inch = 2.54 centimetres
 1 yard = 91.4 centimetres
 1 metre = 39 $\frac{1}{4}$ inches

Most wool manufacturers already market yarns in metric packs and most pattern instructions quote weights of yarns in grams. Again for your guidance we have listed approximate conversions from grams to ounces.

No of balls	Grams	Approx ounces
1	50	1 $\frac{3}{4}$
2	100	3 $\frac{1}{2}$
3	150	5 $\frac{1}{4}$
4	200	7
5	250	9
6	300	10 $\frac{1}{2}$
7	350	12 $\frac{1}{2}$
8	400	14
9	450	16
10	500	17 $\frac{1}{2}$
11	550	19 $\frac{1}{2}$
12	600	21 $\frac{1}{4}$
13	650	23
14	700	24 $\frac{1}{2}$
15	750	26 $\frac{1}{2}$
16	800	28 $\frac{1}{4}$
17	850	30
18	900	31 $\frac{3}{4}$
19	950	33 $\frac{1}{2}$
20	1000	35 $\frac{1}{4}$
21	1050	37
22	1100	38 $\frac{3}{4}$
23	1150	40 $\frac{1}{2}$
24	1200	42 $\frac{1}{4}$
25	1250	44
26	1300	45 $\frac{3}{4}$
27	1350	47 $\frac{1}{2}$
28	1400	49 $\frac{1}{2}$
29	1450	51
30	1500	53

- * Large range of coned yarn
- * 4 ply acrylic – repeatable colours
- * Lister Conifer range – Wool/nylon, Acrylic/nylon
- * Shetland, lambswool
- * Fancy yarns
- * Courtelle/Acrylic fine yarns
- * Lurex

Full range of spares and accessories for all leading makes of knitting machines. Please send SAE for free leaflets on Cut n Sew, the use of industrial yarn, shade cards and our mail order price lists.

Carol Williams,
Metropolitan Sewing Machines,
 Dept J1, 321 Ashley Road,
 Parkstone, Poole, Dorset.

CONVENTION
Bournemouth Town Hall – May 5th
 Meeting of 500 knitters from all over the country Guest speakers, fashion show, demonstrations of machines and wool accessories on sale.

TO & FRO

The postal knitting club for all machine knitters. Quarterly newsletter inc. patterns, Cut n sew course, knitting instruction course, competitions, readers' letters and tips, free punch cards and special offers.

Send SAE for further details.

To & Fro,
 321 Ashley Road,
 Parkstone, Poole,
 Dorset.

Bournemouth (0202) 25001.

24hr ansafone.

Editor – Jane Anthony.

Club Organiser – Carol Williams.

We have managed to secure a reprint of the pattern books for our KH800 machine. These books will be available at a special offer price of £5 from our Manchester office. But hurry as supplies are limited: –

Jones & Brother,
 Shepley Street,
 Guide Bridge,
 Audenshaw,
 Manchester M34 5JD.



MANS WOVEN BATTLEDRESS



Machines

Suitable for most machines

Sizes

To fit 36 (38, 40, 42, 44) in. chest.

Materials

17 (20, 22, 25, 28) 25 gms balls of Beaulon 4 ply Fingering (Hayfields) in Main col. 8 (9, 10, 12, 13, 14) 50 gms balls Hayfields Beaulon crepe chunky in contrast C.

Tension

23 sts. and 40 Rs. to 4 ins. over weaving pattern.

Pattern Notes

KH820/830 machines Stitch patt. 295 from Punchcard patt. Book 1.

KH800 machines: Patt. 298 from Stitchpattern book

KH588 machines: Patt. 282 from Stitchpattern book.

All edgings knitted in M only. Weaving pattern knitted with 4 ply as the knitting yarn and chunky as the weaving yarn.

BACK

Step 1. C.O.B.H. 116 (120, 126, 132, 138) sts. in M. K. 2 Rs. plain at M.T. Change to weaving patt. and continue in patt. throughout. R.C.000 T.D. at M.T., K. to R.C. 120 (130, 140, 150, 160).

Step 2. Cast off 5 (6, 6, 7, 7) sts. at the beg. of the next 2 Rs. Cast off 2 sts. at the beg. of the next 6 (6, 6, 6, 4) Rs. 44 in. only: Cast off 3 sts. at the beg. of the next 2 Rs. ALL sizes: Dec. 1 st. at both sides of next and every foll. alt. R. 5 (6, 6, 7, 7) times in all – 84 (86, 90, 92, 96) sts.

Step 3. K. to R.C. 206 (220, 236, 250, 266). Cast off 5 (5, 6, 6, 5) sts. at the beg. of the next 6 (6, 6, 6, 6) Rs. Cast off 5 (5, 4, 4, 4) sts. at the beg. of the next 4 (4, 4, 4, 6) Rs. Cast off remaining 34 (36, 38, 40, 42) sts.

FRONT (L.H.S.)

Step 1. C.O.B.H. in M., 55 (58, 60, 63, 66) sts. Knit 2 Rs. R.C.000 T.D. at M.T., start weaving patt. and continue in patt. throughout. K. to R.C. 20 – K. 1 extra R. for R.H.S.

Step 2. Cast off 6 sts. at the beg. of the next R. K. to R.C. 60 – K. 1 extra R. for R.H.S. Cast on 6 sts. at the beg. of the next R. K. to R.C. 120 (130, 140, 150, 160) – K. 1 extra R. for R.H.S.

Step 3. Cast off 5 (6, 6, 7, 7) sts. at the beg. of the next R. K. 1 R. Cast off 2 sts. at the beg. of the next and every foll. alt. R. 3 (3, 3, 3, 2) times in all, K. 1 R. 44 in. only: Cast off 3 sts. at the beg. of the next R. K. 1 R. ALL sizes: Dec. q st. at the beg. of the next and every foll. alt. R. 5 (6, 6, 7, 7) times in all – 39 (40, 42, 43, 42) sts. remain.

Step 4. K. to R.C. 185 (199, 215, 229, 245) – K. 1 extra R. for R.H.S. Cast off 4 (5, 6, 6, 5) sts. at the beg. of the next R. K. 1 R. Cast off 2 (2, 2, 3, 2) sts. at the beg. of the next R. K. 1 R. Cast off 2 sts. at the beg. of the next R. K. 1 R. Dec. 1 st. at neck edge on next and every foll. alt. Rs. 6 times in all.

Step 5. K. to R.C. 206 (220, 236, 250, 266) – K. 1 extra R. for R.H.S. Cast off 5 (5, 6, 6, 5) sts. at the beg. of the next and every foll. alt. R. 3 times in all, K. 1 R. Cast off 5 (5, 4, 4, 4) sts. at the beg. of the next and every foll. alt. R. 2 (2, 2, 2, 3) times in all. K. R.H.S. to match L.H.S., noting difference in Rs. worked.

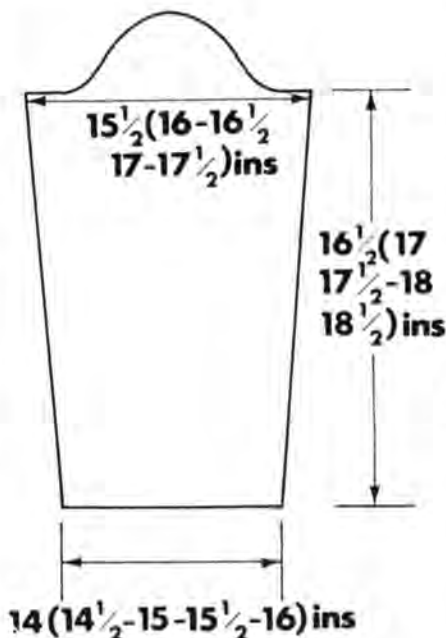
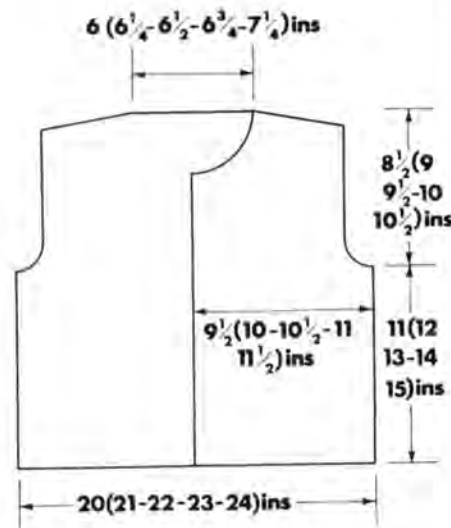

SLEEVES

Cast on 80 (82, 86, 90, 92) sts. in M, with T.D. at M.T. K. 2 Rs. straight. R.C.000 T.D. at M.T., start weaving patt. and work in patt. throughout. K. to R.C. 10 and inc. 1 st. at both sides of next and every foll. 12th R. 5 (5, 4, 4, 4) times in all – 90 (92, 94, 98, 100) sts.

Step 2. K. to R.C. 164 (170, 174, 180, 184). Cast off 5 (6, 6, 7, 7) sts. at the beg. of the next 2 Rs. Dec. 1 st. at both sides of next and every foll. alt. R. 22 (26, 30, 31, 33) times in all. Dec. 1 st. at both sides of next and every foll. R. 12 (8, 4, 4, 1) times in all. Cast off remaining 12 (12, 14, 14, 16) sts.

POCKETS

Step 1. With wrong side of work facing and Carr. at L.H.S. of bed, pick up between cast off and cast on points on Front piece, 28 sts. T.D. at M.T., K. 1 R. Carr. at right. Transfer sts. for 2x1 rib, with T.D. at M.T. – 2, K. 26 Rs. and pick up every sts. to replace onto empty Ns. (to form pocket hem).

Step 2. T.D. at M.D., K. 70 Rs. and cast off.

FRONT EDGE BANDS

Buttonholes band: With right side of work facing, pick up from front edge 114 (126, 136, 146, 156) sts. T.D. at M.T., using M, K. 6 Rs. Counting from bottom edge of work make buttonholes over sts. as follows: 6, 7, 8 and 9: 29, 30, 31 and 32: 52, 53, 54 and 55: 75, 76, 77 and 78: 98, 99, 100, 101: (6, 7, 8 and 9: 33, 34, 35 and 36: 60, 61, 62 and 63: 87, 88, 89 and 90: 114, 115, 116 and 117: – 6, 7, 8 and 9: 35, 36, 37 and 38: 64, 65, 66 and 67: 93, 94, 95 and 96: 122, 123, 124 and 124: – 6, 7, 8 and 9: 38, 39, 40 and 41: 70, 71, 72 and 73: 102, 103, 104 and 105: 134, 135, 136 and 137: – 6, 7, 8 and 9: 40, 41, 42 and 43: 74, 75, 76 and 77: 108, 109, 110 and 111: 142, 143, 144 and 145). K. 12 Rs. then make buttonholes over same sts. as before, K. 8 Rs. and strip off with waste yarn. Before continuing with other edgings, finish off front edge by backstitching through last row knitted in the main colour.

Button Band: K. as for buttonhole band, omitting buttonholes – finish as above.

NECKBAND AND COLLAR

(Join shoulder seams)
With wrong side of work facing, pick up along front (inc. edgings), back, and along 2nd front, sts. as follows: 27

LONG NIGHTDRESS

(31, 35, 39, 43) sts. from 1st Front, 34 (36, 38, 40, 42) sts. from Back and 27 (31, 35, 39, 43) sts. from 2nd Front. T.D. at M.T., using M, K. 4 Rs. T.D. at M.T.-1, K. 4 Rs. T.D. and M.T., inc. 1 st. f.f. at both sides of next and every foll. 4th R, 12 times in all. K. to R.C. 56 and dec. 1 st. at both sides of next and every foll. 4th R, 12 times in all. T.D. at M.T.-1 K. 4 Rs. T.D. at M.T., K. 4 Rs. Pick up every 3rd sts. from 1st R. picked up and cast off all sts. together LOOSELY.

BOTTOM EDGING BANDS

BACK

Push into W.P. 79 (82, 86, 90, 94) sts. With wrong side of work facing, pick up sts. from bottom back and replace onto machine as folls: st. on 1st 2 (3, 3, 3, 3) Ns. * 2 sts. on next N, 1 st. on next N* repeat from * to * throughout to last 3 Ns. 1 st. on last 3 Ns. T.D. at M.T., K. 30 Rs. straight. Pick up sts. from 1st R. picked up (every 3rd sts.) and cast off all sts. together LOOSELY.

FRONTS

Buttonhole band: With wrong side of work facing, push 40 (42, 43, 45, 47) Ns. into W.P. Carr. at same side as front facing, replace sts. onto machine as folls:

1 sts. on to 1st 5 Ns, *2 sts. onto next N, 1 st. onto next N*, repeat from * to * to last 5 (5, 4, 4, 4) Ns, 1 sts. on last 5 (5, 4, 4, 4) Ns. Join yarn to work and cast on 14 sts. in front of front facing band. T.D. at M.T., using M, K. 8 Rs. straight. Counting sts. from overlap front edge, make buttonhole over sts. 7, 8, 9 and 10. K. 14 Rs. straight and make buttonhole over same sts. as before. K. 8 Rs. and pick up every 3rd sts. from 1st R. picked up and cast off all sts. together LOOSELY.

Button band: K. as for buttonhole band, omitting buttonhole.

SLEEVE EDGINGS

With wrong side of work facing, pick up and replace sts. onto 42 (43, 45, 47, 48) Ns. as folls: 1 sts. on 1sr 2 Ns, *2 sts. on next N*, repeat from * to * to last 2 Ns, 1 sts. on last 2 Ns. T.D. at M.T., using M, K. 30 Rs. and pick up every 3rd sts. from 1st row picked up, cast off all sts. together LOOSELY.

TO MAKE UP

Set in sleeves. Sew cast off side of pocket to matching position on back side seam. Join remainder of side seam. Join sleeve seams. Finish off all edging bands by sewing seams neatly. Give final light press.



Measurements

To fit bust: 81cm (32"), 86cm (34"), 91cm (36"), 97cm (38").

Materials

Mailyarns Ltd., 38 High Street, Syston, Leicester, LE7 8GP.
Bancot 4ply cotton. 2½ cones.

Tension

Always check tension before commencing.

T4 40 sts = 11cm and 60 rs = 13cm.
(Success depends on working to correct tension.)

Notes

Lace Card No. 21D from Basic pack. K m/c KH830.

BACK (left)

Insert card and lock on row 1. In W.WI. cast on 119 (123, 127, 131) sts. Knit a few rs. Change to M.WI. T3 knit 20 rs. Make hem and knit the row. Carr to right. RC 000. T4. (Release card and work in lace to row 80 then work in st.st.) Dec 1 st at right on next and ev foll 12th row until 79 (83, 87, 91) sts rem. Knit to 578 rs. Cast off 4 sts at beg of next row. Knit 1 row. RC 000. Knit to 46 rs and cont in lace. * Knit to 112 rs then start **shoulder shaping**. Cast off 7 (9, 11, 13) sts at beg of next row. Knit 1 row. Cast off 4 sts at beg of next and ev foll 2nd row until 32 (34, 36, 38) sts rem. Cast off.

BACK (right)

Knit to match reversing all shapings.

FRONT (left)

Knit as back to *. For **neck shaping** dec 1 st at left on next and ev foll 4th row. Work to 112 rs then start **shoulder shaping**. Cast off 7 (9, 11, 13) sts at beg of next row. Knit 1 row. Cast off 4 sts at beg of next and ev foll 2nd row until 7 (9, 11, 13) sts rem. Cast off.

FRONT (right)

Knit to match reversing all shapings. Join shoulder seams and mark centre back neck.

ARMHOLE EDGE

With W.WI. cast on 120 sts. Knit a few rs. Change to M.WI. T3. Knit 12 rs. Turn up hem. With wrong side of work facing pick up 120 sts along armhole edge and place on nds. Cast off.

NECK EDGE

With W.WI. cast on 140 sts. Knit a few rs. Change to M.WI. T3. Knit 2 rs. * Dec 1 st at each end of next row, knit 1 row * rep once more. Inc 1 st at beg of next 4 rs. Knit 2 rs. Turn up hem. Pick up 140 sts along neck edge from centre front to centre front, place on nds. Cast off.

Join all rem seams and press.



Blouse with woven Lace Sleeves and Bolero

Materials

Silverknit 1 cone Saturn, 1 cone Dakota, $\frac{1}{2}$ m x $\frac{1}{2}$ " ribbon, 20 buttons

Measurements

To fit 32 (34, 36) in bust.

Tension

Bodice 9 sts. x 10 $\frac{1}{2}$ rs = 1 in in st. st.

T3

Sleeves 7 sts. x 12rs = 1 in T4

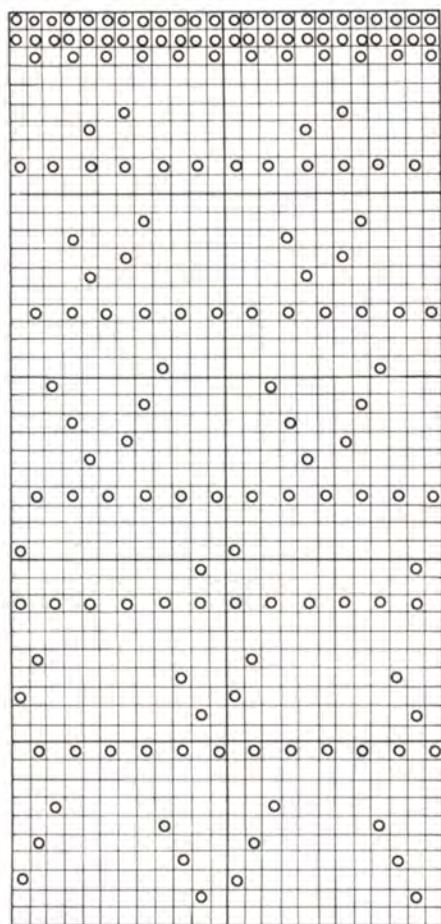

Notes

M/c set to KC for lace work. The empty rows on the card allow the lace carriage to pass to the left. Knit with lace carriage until every alternate N comes forward. At this point weave 2 rows with knit carriage (Ns will stay

forward to allow for this as both carriages are travelling in the same direction). Woven lace is not difficult, but slow to do I acknowledge the work of Kathryn Hobbs in sorting out this technique. Special card: as shown.

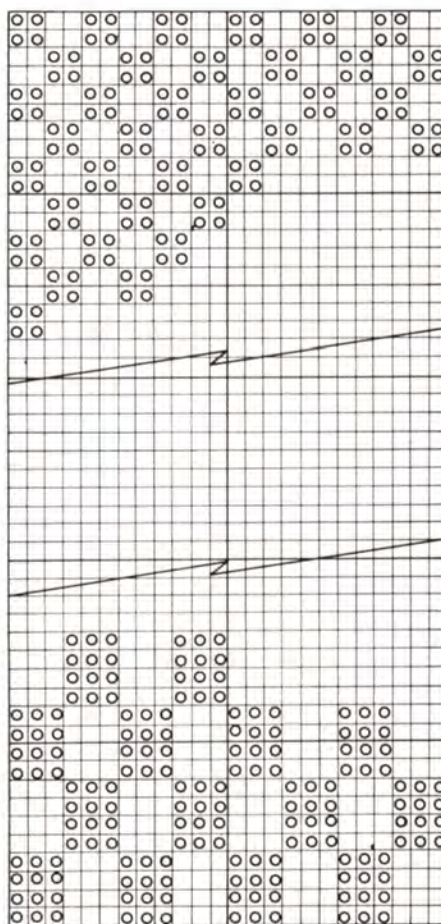

BLOUSE

Back

Step 1. Cast on 130 (138, 140) sts K40 rows T2 MDE

Step 2. 000 T3 Inc 1st each and every 10th row to row 120 (125, 130)

Step 3. 000 Mark end N at this point with coloured yarn. Cast off 1st this

and every 10th row to row 090 (095 100). Cast off 3 sts beginning each row to row 116 (118, 120) C/O.

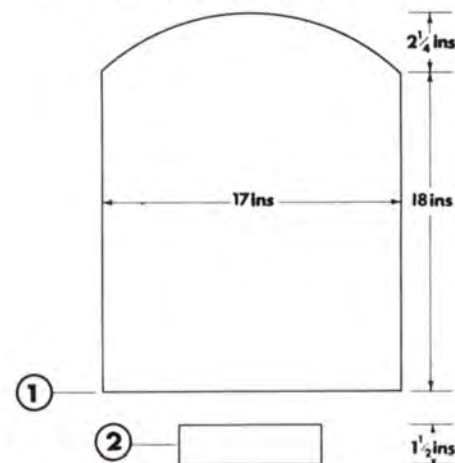

FRONT

Step 1. As back.

Step 2. Thread up 8 sts to left of centre O. Place all other Ns on left side in holding post. Wind on by hand 8 sts at centre front for buttonhole band, adjoining right front. 000 at 10th and every following 10th row transfer the 4th and 8th N from centre front for buttonhole, leaving empty N in working from position. Also at

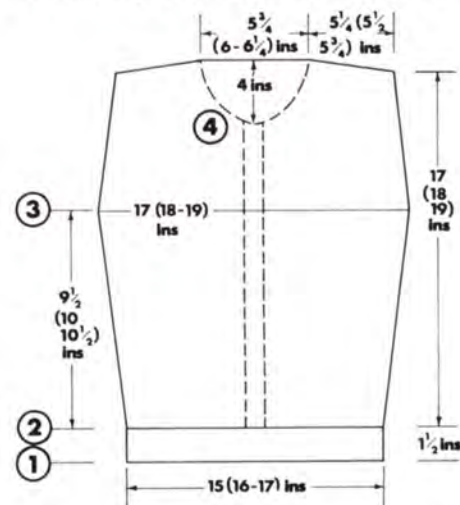

every 10th row inc. 1st at right. Continue in this manner to row 120 (125, 130).

Step 3. Mark end st with coloured yarn. Continue to work buttonholes, dec 1st at right every 10th row to row 060 K10 rows c/o 23 (24, 25) sts at neck edge.

Step 4. Dec 1st at neck every 5th row and at the same time continue to dec. 1st at edge every 10th row, to 090 (095 100) Cast off 3 sts at right every alt. row, and at the same time dec. 1st at neck every 5th row until all sts are removed.

To work left front

Step 1. Pick up 4 sts adjoining left front from the 8 threaded up stitches. RC 000.

Step 2. Inc. 1st at left every 10 rows to row 120 (125, 130)

Step 3. 000 Mark end N as before. C/O 1st at left every 10rs to row 060 K10 rows c/o 19 (20, 21) at neck edge.

Step 4. Knit as step 4 for right front, reversing shapings.

SLEEVES

Step 1. Cast on 120sts in waste yarn K a few rows waste C.O.L. 000 K3 rows main yarn T4. C.O.R. Work lace carriage until every alternate N is brought forward. Weave two rows with boucle yarn. Continue to row 190 c/o 5 sts at beginning each

woven row until all sts are removed.

Step 2. Cuffs. Cast on 60Ns K40 rows T2 MDE. With right side facing m/c attach sleeve above waste yarn, placing 2 sts to each N. c/o.

TO MAKE UP

Graft the 8 sts wound on by hand on rt front to the 4 threaded-up, folding buttonhole band in to match the holes. Catch down buttonhole band facing. Sew on narrow ribbon to front edge of left front to carry buttons. Join all seams, coloured threads will indicate upper limit of side seams. Work 3 rows double crochet around neck, working one buttonhole on right front.

BOLERO

Worked in remaining boucle yarn.

TENSION

6 sts x 10rs = 1" TD approx. 5.

BACK

Step 1. C.O.B.H. 120 (126, 132) sts K209 (219, 229) rs K1 row T7; K1 row T10 c/o.

FRONT (2 reversing shapings)

Step 1. Bring forward 60, 63, 66 Ns Push back 30 Ns nearest centre of m/c to A position C.O.B.H. the remaining 30 (33, 36) Ns. Inc. 1st at left every alt. row until you have 60 (63, 66) sts in action.

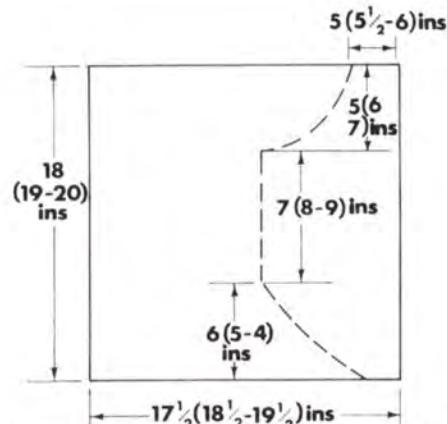

Step 2. Continue straight to row 146 (156, 166) c/o 13 (15, 17) at left. c/o 1st at left every alt. row 10 times. Continue straight to row 209 (219, 229) c/o.

NECK TIE BAND

Cast on five sts over 9 Ns, ie



*K2 rows bring into holding position 2nd & 4th Ns K4 rows push back 2nd and 4th Ns and repeat from * until band measures 50" c/o.

To make up

Join seams
Sew neck tie around neck folding in half over raw edges.
Work 2 rows double crochet around all raw edges.

Make it with **MAILYARNS**...you'll notice the difference!

You'll be agreeably surprised to learn that our machine knitting yarns cost no more than ordinary yarns and are also supplied POST FREE.

'Goscote' (4 Ply)

100% Acrylic on 340g cones. Available in 32 colours including most school shades. A revelation in Quality and Economy

'BANCOT' (2 ply & 4 ply)

100% Cotton on 200g cones. A delightful colour range in this mercerised quality.

FINE PLY (2/30s)

100% Acrylic on 250g cones. In a range of popular colours.

ALL OUR YARNS ARE SPUN SPECIFICALLY FOR MACHINE KNITTING & ARE FULLY REPEATABLE

'SHETLANDIA' (3 ply)

Shetland style 100% Pure New Wool on 400g cones. A quality-plus yarn in a range of top fashion shades.

'FYNWUL' Botany 2ply

100% Pure New Wool on 200g cones. The ultimate top fashion yarn in a superb colour range.

WE ALSO STOCK:

100% Pure New Wool ARAN Machine Weaving Yarns, Labels, Invisible Thread, etc.

Send S.A.E. for FREE samples (quote product interest) to:
MAILYARNS LTD, (Dept J2) 38, High Street, Syston, Leicester.

Discounts are available on bulk orders please ask for details

HONEYCOMB SWEATER



Measurements

To fit 34 (36, 38, 40) inch bust, fairly loosely

Materials

Hayfields Beaulon 4 - 4-ply fingering 400 (400, 425, 425) grms i.e. 12 (12, 13, 13) 25gr balls.

Tension

Measure on 'plain' side, allowing swatch to rest an hour first. TD8. 9 rs x 4 sts (over alt nds) = 1".

820 - 830 m/c card 2 x 2 check knitted on alt nds.



BACK

Step 1: Ribbers: Note, use the side weights as well as comb weights. Cast on 152 (160, 168, 176) sts in 1 x 1 rib. Knit 3 rs tub. TD2¹/₃ Knit 50 rs (knitting last row on T5/6). Transfer to main bed placing sts on nds already carrying a st. This will be easier if you rack the ribber bed one pos. Main bed now in 1 x 1 formation. S/bed m/c: TD5. Cast on 152 (160, 168, 176) sts in 1 x 1 mock rib. Knit 100 rs MDE. placing sts on nds already carrying a st.

Step 2: Insert card and set the m/c for patt. Depress both tuck buttons. RC 000, knit in tuck st to row 240, cast off 3 actual sts beg next 2 rs.

Step 3: RC 000. Dec 1 st each end of 10th, 20th, 30th row. Continue straight to row 100, knit one row st.st. Cast off.

BACK NECK

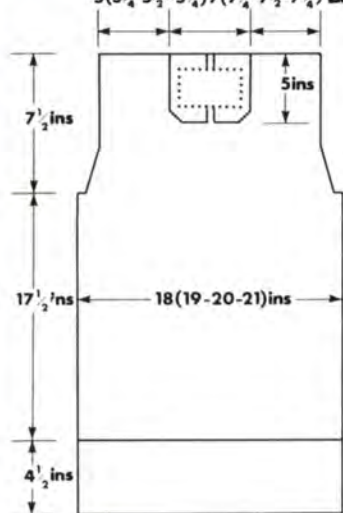

BACK+ FRONT

FRONT

Step 1 and Step 2: As back.

Step 3: RC 000. Dec 1 st each end of 10th, 20th, 30th row. Continue straight to row 40. With a length of

yarn cast off the centre 17 (19, 21, 23) sts. Note row No. on card. Knit one side of neck first, leaving row tripper in action.

Step 4: Dec 1 st at neck edge every alt row 3 times. Continue straight to row 100. Cast off.

SLEEVES

Step 1: Using waste yarn, cast on over 122 (130, 138, 146) nds giving 61 (65, 69, 73) sts in alt nd arrangement. Knit a few rs waste COR.

Step 2: Knit one row main yarn. Set m/c for patt. T8, RC 000, knit 240 (245, 250, 255) rs. Cast off three actual sts beg next 2 rs (loosely to allow for missing nds). Dec 1 st each end every alt row to row 260 (265, 270, 275). Cast off loosely.

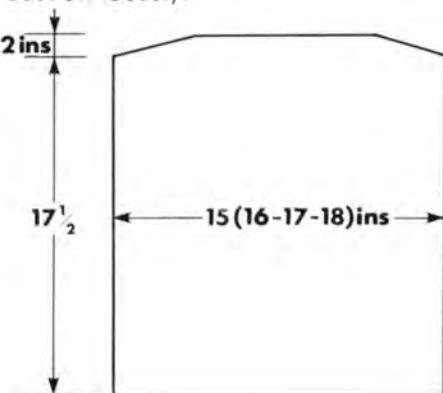

SLEEVE

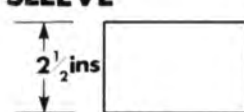

CUFF

CORD 70ins LONG

CUFF

Ribbers:

Step 1: Cast on 61 (65, 69, 73) sts in 1 x 1 rib. Knit 3 rs tub. Knit 30 rs T2¹/₃ Transfer to empty nds on main bed.

Step 2: Attach sleeves to cuff above waste knitting. Cast off.

S/beds m/cs:

Step 1: Cast on 61 (65, 69, 73) sts in 1 x 1 mock rib. Knit 60 rs TD5, MDE.

Step 2: As step 2 for ribbers.

NECKBANDS (knit 2)

Cast on 100 nds in 1 x 1 mock rib TD5¹/₃. Knit 16 rs MDE. Attach front and back from centre points. Cast off. Cord: Make a long cord over 3 sts to tie in a bow at neck. Insert into neckband. Sew bands at back and front. Pom Poms: Make 2 with left over yarn, attach to cord ends. Trim if necessary to neaten pom pom.

Join all remaining seams.

LADIES BLOUSON WITH FRILLY NECKLINE

Measurements

To fit 32 (34, 36, 38, 40) in bust.

Materials

16 (18, 21, 23, 26) balls Poppletons Bijou Double Knitting.

Machines

Suitable for any machine with ribbing attachment.

Tensions

24 sts and 31 rows to 4 ins with TD approx 10.

BACK

Step 1: Using ribber, cast on in 1 x 1 rib 119 (125, 131, 137, 143) sts. TD at MT-3/MT-3, knit 16 rows. Transfer sts to main bed and inc 1 st - 120 (126, 132, 138, 144) sts.

Step 2: RC 000 TD at MT, knit to RC 84 (92, 100, 108, 116). Cast off 6 sts at the beg of the next 2 rows. 108 (114, 120, 126, 132) sts remain.*

Step 3: Knit to RC 142 (154, 166, 178, 190). Cast off 10 (10, 11, 11, 12) sts at

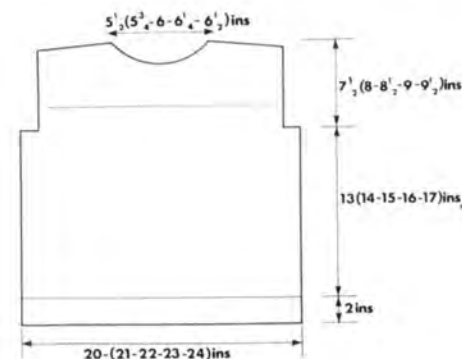

the beg of the next 4 rows. Cast off 9 (10, 10, 11, 11) sts at the beg of the next 4 rows. Cast off remaining 32 (34, 36, 38, 40) sts.

FRONT

Step 1: Knit as Back to *.

Step 2: Knit to RC 126 (138, 150, 162, 174). Cast off 8 (8, 10, 10, 12) sts at centre. Put LHS into HP and knit RHS as follows:

Step 3: Knit 1 row. Cast off 2 sts at the beg of the next and foll alt row, knit 1 row. Dec 1 st at neck edge on next and every foll row 8 (9, 9, 10, 10) times in all *and at the same time*, knit to RC 142 (154, 166, 178, 190).

Step 4: Cast off 10 (10, 11, 11, 12) sts at the beg of the next and foll alt row, knit 1 row. Cast off 9 (10, 10, 11, 11) sts at the beg of the next and foll alt row. Take carr to LHS of work, turn RC back to 126 (138, 150, 162, 174). Return sts to WP and knit LHS to match RHS.

SLEEVES

Step 1: COBH 90 (96, 102, 108, 114) sts. TD at MT, knit to RC 112 (116, 120, 124, 128). Push 10 Ns at opp side to carr into HP (always taking the yarn under the first needle and over the rest in HP to prevent hole), on the next 4 rows. Push all Ns at opp side to carr back to WP on next 2 rows. Knit 2 rows and cast off.

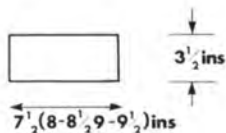
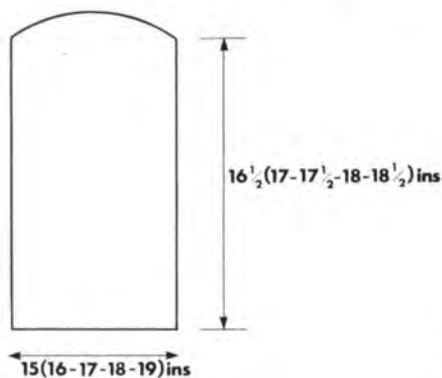

CUFFS

With carr at left of machine and wrong side of work facing, push 45 (48, 51, 54, 57) Ns into WP and replace cast on edge of sleeve onto Ns, by putting 2 sts onto each needle. TD at MT, knit 1



row. Transfer sts for 1 x 1 rib, add weights. TD at MT-3/MT-3, knit 34 rows. Transfer sts to main bed and cast off in rib configuration.

NECK FRILL

Using ribber, cast on in 1 x 1 rib, 168 (176, 184, 192, 200) sts. TD at MT/MT, knit 6 rows. TD at MT- , knit 6 rows, TD at MT- , knit 6 rows, TD at MT-1 knit 8 rows and transfer sts to main bed. TD at MT, knit 2 rows and strip off with waste yarn.

NECKBAND (Join 1 shoulder seam)

With right side of work facing, pick up and replace 52 (54, 56, 58, 60) sts from front and 32 (34, 36, 38, 40) sts from

back. Replace frill onto same sts with right side facing, 2 sts onto each needle. Put all (working) Ns into HP, leaving carr set so that these Ns will knit for 1 row. Knit with TD at MT-1, 16 rows and strip off machine with waste yarn.

TO MAKE UP

Join 2nd shoulder seam. Join frill seam. Turn neckband in half onto right side and backstitch through last loops knitted in the main colour and remove waste yarn. Set in sleeves. Join side and sleeve seams. Make cord long enough to thread through waistband and tie (as shown). Give final light press.

BATWING CARDIGAN

Measurements

To fit bust: 81cm (32"), 86cm (34"), 91cm (36"), 97cm (38")

Materials

1 cone Dakota from: Silverknit, The Old Mill, Epperston By-Pass, Woodborough, Nottingham NG14 6DH.

Tension

Always check tension before commencing.

T5 40 sts = 16cm and 60 rs = 14cm. (Success depends on working to correct tension.)

Notes

Card used from Jones Big and Bold pack punch card set Vol. 5 Card No. 406.

BACK

Insert card and lock on row 1. With W.Wl. cast on 128 sts as 2 x 1 mock rib. Knit a few rs. T4. Change to M.Wl. and knit 60 rs. RC 000. Turn up hem and knit the row. Release card and work in lace. Carr on right. Inc 1 st at each end of next and ev foll 6th row until there are 156 sts. Knit to 90 rs. RC 000.

Cast off 3 sts at beg of next 2 rs. Dec 2 sts at each end of ev 4th row until 26 sts rem. Knit to 130 rs. Cast off.

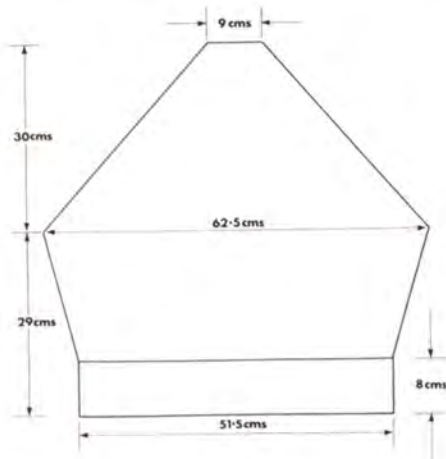

SLEEVES (both alike)

Insert card and lock on row 1. With W.Wl. cast on 77 sts as 2 x 1 mock rib.

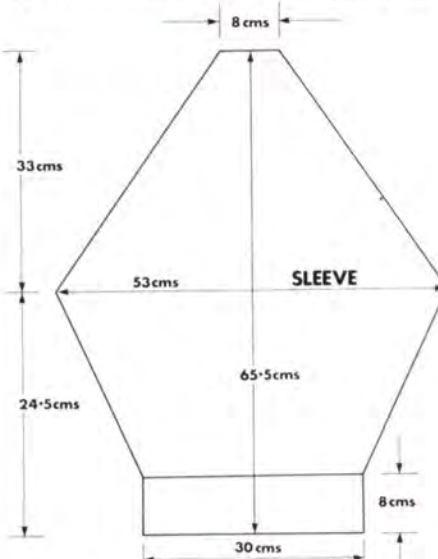

T4, change to M.Wl. and knit 60 rs. RC 000. Turn up hem and knit the row. Release card and work in lace. Carr on right. Inc 2 sts at each end of next and ev foll 5th row until there are 131 sts (RC 72). RC 000.

Cast off 3 sts at beg of next 2 rs. Dec 2 sts at each end of ev 5th row until there are 21 sts. Knit to 140 rs. Cast off.

FRONT

Insert card and lock on row 1. With W.Wl. cast on 62 sts as 2 x 1 mock rib. Knit a few rs, T4. Change to M.Wl. and knit 60 rs. RC 000. Turn up hem and knit the row. Release card and work in lace. At left, inc 1 st ev 5th row until there are 76 sts. Knit to 90 rs. RC 000. Carr to left, dec 2 sts at left ev 4th row. Work shaping to row 18, then start neck shaping.

Work raglan shaping at same time as dec 1 st at neck edge on next and ev 9th row. Work these two shapings together until all sts are cast off.

Work other side reversing all shapings.

MAKE UP

Pin out all pieces and press lightly. Join raglan seams and mark centre back.

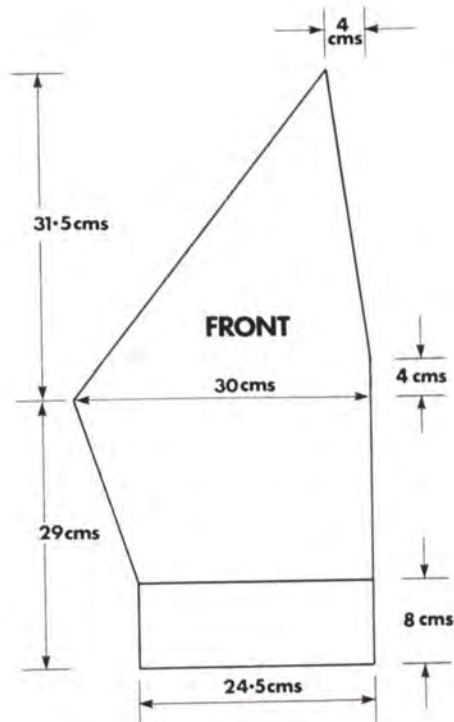

BUTTON BAND

With W.Wl. cast on 190 sts. Knit a few rs. Change to M.Wl. T4. Knit 30 rs. Make hem. Pick up 190 sts along centre front from hem to centre back and place on nds (wrong side facing). Cast off.

BUTTONHOLE BAND

Mark position on button band for 6 buttons, the last one at beg of neck shaping. Knit as button band, making button holes to match markers over 2 sts on rs 7 and 23. Knit to 30 rs.

MAKE UP

Join centre back seam. Join seams from cuffs to hem. Press lightly.



Ladies Lace Dress with long sleeves

Measurements

To fit small (32/34") or medium (36/38").

Materials

2-500 gm cones 'So Soft' 2/16s pure wool — obtainable by mail order from Stagport Ltd., P O Box 24, Slough, Berks, SL1 2NW. (Send 15p for shade card and order form; refundable on first order.)

Machines

Suitable for KH830 machines only

Tensions

Note: 2 strands yarn used together throughout all of dress.

Plain knitting: 32 sts and 38 rows to 4 ins (10 cms). TD approx 6.

Fine lace: 32 sts and 42 rows to 4 ins (10 cms). TD approx 6.

'Normal' lace: 32 sts and 42 rows to 4 ins (10 cms). TD approx 5.

Notes

Yarn used 2 stranded throughout. Patt No. 40 from Vol 2 pattern book.

SKIRT FRILL (4 alike)

Step 1: COBH 168 (192) sts. TD at 4, knit 10 rows. Make picot, knit 1 row, TD at 9, knit 9 rows, TD at 4 and turn hem.

Step 2: RC 000, TD at 5, knit 2 rows plain and start normal lace patt, work-

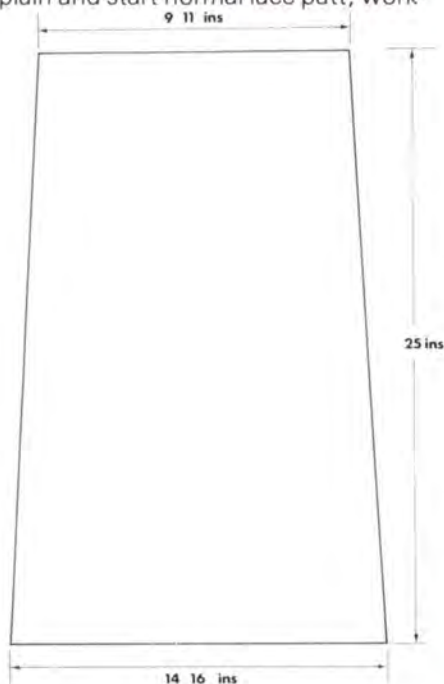

ing pieces in normal lace throughout. Knit to RC 90 and strip off with waste yarn. Make 3 more frills alike.

SKIRT PANELS (4 alike)

Step 1: Push 112 (128) Ns into WP. With wrong side of frill facing, replace sts onto machine as folls: * 2 sts on 1st N, 1 st on next needle*. Repeat from *-* throughout — 112 (128) sts.

Step 2: TD at 6, knit 2 rows and start fine lace patt, working in lace throughout, knit to RC 8. Stop RC counting.

Knit 9 sts (at opp side to carr) back to 'rest' pos on next row, when carr has passed these sts, knit 10th st back to 'rest'. Repeat from *-*, 8 (10) times in all. Unravel cord (on sts at rest) at opp side to carr on next 2 rows — all Ns back into WP.

Step 3: Start RC counting again and dec 1 st at both sides of next and every foll 12th row 20 times in all — 72 (88) sts remain. Knit to RC 262 and strip off with waste yarn. Repeat the same with other 3 panels.

BACK BODICE

Step 1: Join 1 panel seam.

Step 2: Push 136 (152) Ns into WP and with wrong side of work facing replace sts onto machine as folls: 1 st on 1st 7 (7) Ns, *2 sts on next needle, 1 st on next 17th (6th) needle*. Repeat from *-* throughout. Work in plain knitting throughout.

Step 3: RC 000 TD at 6, knit to RC 004. Cast off 3 (4) sts at beg of next 4 rows. Dec 1 st at both sides of next and foll alt row — 120 (132) sts remain. Knit to RC 70 (80).

Step 4: Cast off 8 (9) sts at the beg of the next 2 rows. Cast off 7 (8) sts at the beg of the next 8 rows. Cast off remaining 48 (50) sts.

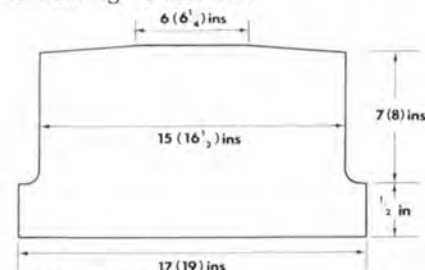

FRONT BODICE (RHS)

Step 1: With carr at right (left for LHS), push 64 (72) Ns into work.

Step 2: With wrong side of work

facing, starting at right edge for RHS (left for LHS) replace panel onto Ns by putting * 1 st on 1st 15 (11) Ns, 2 sts on next N*. Repeat from *-* throughout (there should be 4 sts from panel left at LHS (RHS for left front). Put extra sts onto stitch holder and strip off waste yarn. Plain knitting throughout.

Step 3: RC 000 TD at 6, knit 4 rows straight. Cast off 3 (4) sts at the beg of the next and foll alt row. Knit 1 row. Dec 1 st at the beg of the next and foll alt row — 56 (66) sts remain. Knit to RC 41 (51).

Step 4: Cast off 7 (8) sts at the beg of the next row, knit 1 row. Cast off 4 (6) sts at the beg of the next row, knit 1 row. Cast off 3 (5) sts at the beg of the next row, knit 1 row. Dec 1 st at the beg of the next and every foll alt row 6 times in all — 36 (41) sts remain.

Step 5: Knit to RC 70 (80). Cast off 8 (9) sts at the beg of the next row, knit 1 row. Cast off 7 (8) sts at the beg of the next and every foll alt row 4 times in all. LHS — Knit as for RHS, noting difference in starting side for carr and positions for shaping.

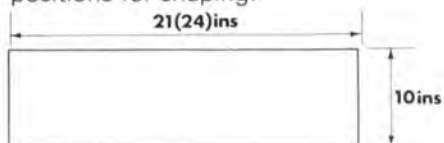

FRONT EDGING

Buttonhole Band

With wrong side of work facing, pick up from right-hand front edge 34 (42) sts. TD at 5, knit 2 rows*. Transfer 7th, 17th and 28th (9th, 21st and 33rd) sts to their adj needle leaving empty Ns in work*. Knit 4 rows and make picot edge, knit 1 row TD at 9, knit 3 rows TD at 5, then repeat from *-*. Knit 2 rows. Pick up every 3rd st from 1st row picked up for edging and cast off all sts together LOOSELY.

Button Band

With wrong side of work facing, pick up and replace from front edge 34 (42) sts. TD at 5, knit 12 rows. Pick up every 3rd st from 1st row picked up and cast off all sts together LOOSELY.

SLEEVES

Step 1: COBH 100 (108) sts. TD at 4, knit 10 rows and make picot. TD at 9, knit 1 row, TD at 4, knit 9 rows and turn hem.

Step 2: RC 000 TD at 5, knit 2 rows, start normal lace patt and work in normal lace to RC 032.

Step 3: Change to fine lace patt, TD 6, and knit straight to RC 168 (172). Cast off 3 (4) sts at the beg of the next 2 rows. Dec 1 st at both sides of next and every foll alt row 11 (16) times in

all. Knit 1 row. Dec 1 st at both sides of next and every foll row 28 (24) times in all. Cast off remaining 16 (20) sts.

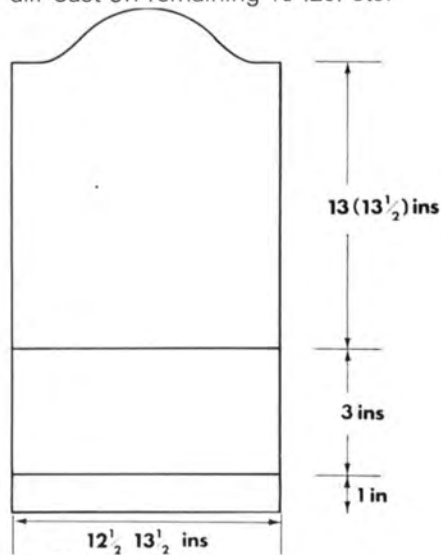

NECKBAND

Join shoulder seams.

With right side of work facing, pick up 48 (50) sts from back neck and 24 (30) sts from front neck (from one front neck piece only). TD at 5, knit 6 rows, make picot edge. TD at 9, knit 1 row. TD at 5, knit 7 rows and strip off machine with waste yarn.

2nd part of front neck: pick up from shoulder to front of 2nd front neck piece 24 (30) sts and knit as for back plus one front band above.

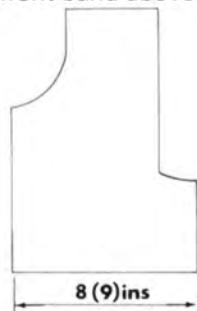

TO MAKE UP

Press according to measurements given with a wet cloth and med hot iron (do not stretch work). Leave to cool and dry. Sew centre front seam up to front edging, grafting the 4 sts from stitch holder onto 2 front edge facings. Set in sleeves. Sew side and sleeve seams. Turn neckband into half onto right side (so that picot edge is crease line) and backstitch through the last loops knitted in the main colour. Sew 3 buttons to correspond with little buttonholes on front edge. Knit 2 cords, long enough to thread through lace at sleeves at join of normal and fine lace patt. Give final press.



Soft Lacy Suit

Measurements

To fit bust: 81cm (32"), 86cm (34"), 91cm (36"), 97cm (38")

Skirt to fit waist: 61cm (24"), 66cm (26"), 71cm (28"), 76cm (30")

Skirt to fit hip: 87cm (34"), 92cm (36"), 97cm (38"), 102cm (40")

Materials

1½ cones of Kyoto from: Silverknit, The Old Mill, Epperston By-Pass, Woodborough, Nottingham NG14 6DH.

Tension

Always check tension before commencing.

Sweater Tension

T10 over lace pattern 40 sts = 17cm and 60 rs = 22cm.

Skirt Tension

T8 over st.st. 40 sts = 14.5cm and 60 rs = 19cm.

Notes

Card used from Jones Big and Bold pack punch card set Vol 5 Card No. 405.

1" elastic to fit waist.

SWEATER

Back and Front alike

Insert card and lock on row 1. With W.Wl. cast on 119 (125, 131, 137) sts as 2 x 1 mock rib. Knit a few rs. Change to M.Wl. T7. Knit 50 rs. Make hem and knit the row. Release card and work in lace. Knit to 94 rs or required length.

For Raglan shaping

RC 000. Dec 3 sts ev 4th row. Work dec to row 36.

For Neck shaping

Cast off centre 19 (25, 31, 36) sts. Put left side of work onto W.Wl. and release from machine.

Cont raglan shaping at same time as casting off 4 sts ev 2nd row at neck edge. Work the two shapings tog until 3 sts rem. Cast off. Replace left side on nds.

Work to match right side reversing all shapings.

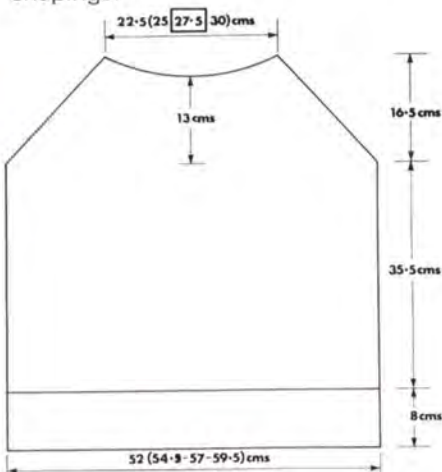

Sleeves - alike

Insert card and lock on row 1. With W.Wl. cast on 48 (54, 60, 66) sts as 2 x 1 mock rib. Knit a few rs. Change to M.Wl. T7. Knit 50 rs. Make hem and knit the row. Release card and work in lace. Inc 2 sts at each end of ev 8th row until there are 92 (98, 104, 110) sts. Knit to 94 rs or required length.

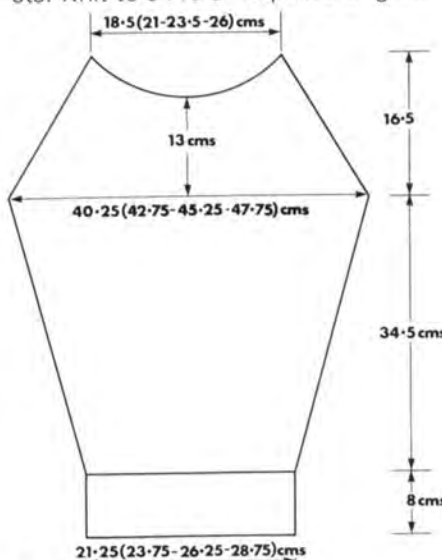

For Raglan shaping

RC 000. Cast off 2 sts at beg of next 2 rs, dec 2 sts at each end of ev foll 4th row. Work dec to row 36. Carr to right.

For Neck shaping

Cast off centre 16 (22, 28, 34) sts, put left side of work onto W.Wl. and release from machine. Cast off 4 sts at neck edge ev 2nd row until 6 sts rem. Cast off.

Frill

C.O.B.H. 12 sts. Knit 200 rs. T10. Cast off.

Neckband

With W.Wl. cast on 182 (188, 194, 200) sts. Knit a few rs. Change to M.Wl. T10, knit 10 rs. T8, knit 10 rs. T6, knit 20 rs. T8, knit 10 rs. T10, knit 10 rs. Turn up hem and cast off.

SKIRT Back and Front alike

With W.Wl. cast on 179 (186, 193, 200) sts as 2 x 1 mock rib. Knit a few rs. Change to M.Wl. T7, knit 20 rs. Make hem and knit the row. Carr to right.

To shape hem

T8. RC 000. Put 50 nds on left side into H.P. Carr to left. Put 50 nds on right side into H.P. Carr to right. *Push 10 nds on left back into W.P. Carr to left. Push 10 nds on right centre back into W.P. * Rep until all nds are in W.P.

RC 000. Dec 2 sts at each end of next and ev foll 10th row until 111 (118, 125, 132) sts rem. Knit to 174 rs.

RC 000. Dec 2 sts at each end of next and ev foll 4th row until there are 87 (94, 101, 108) sts. Knit to 24 rs. Change to W.Wl. Knit a few rs. Release from machine.

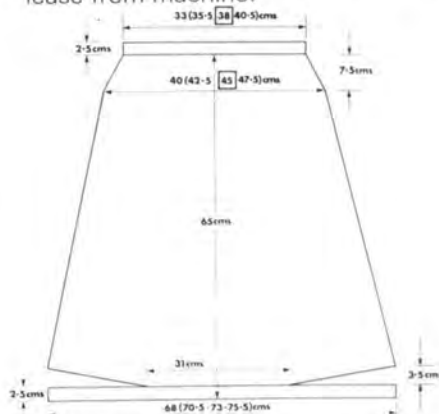

Waistband

In W.Wl. cast on 87 (94, 101, 108) sts as 2 x 1 mock rib. Knit a few rs. Change to M.Wl. T7, knit 20 rs. Turn up hem and knit the row. Put last row of M.Wl. of skirt onto nds. Cast off.

Make other side to match.

MAKE UP

Press all pieces. Neckband should be pressed into a circle. Join raglan seams. Join underarm and side seams, neckband and frill seams. Pin frill along neck edge and run a gathering thread through both. Mark neckband into 4 parts and gather onto each part evenly the front back and sleeves, backstitch firmly along this seam.

Join side seams of skirt leaving one inside hem seam open at waist. Thread with elastic and join securely. Press all seams.



Ladies Lace Suit

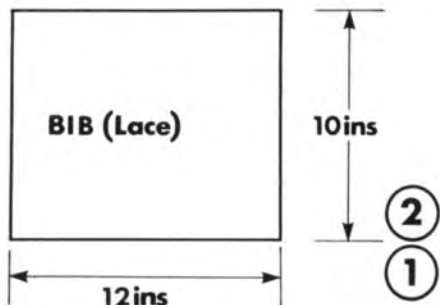

BACK

Step 1: Ribbers: Bring forward 128 (136, 144, 152) nds on each bed. Arrange for 2 x 1 rib (knit 2 purl 2 rib). Knit 3 rs tub. Knit 60 rs. T 2/3 transfer to main bed.

S/bed m/cs: Cast on 128 (136, 144, 152) nds in 2 x 1 mock rib. Knit 120 rs. T3 MDE.

Step 2: RC 000* TD5. Knit 2 rs st.st. (lengthen here if required). Cast off 10 sts beg next 2 rs.

Step 3: RC 000. Knit without shaping to row 130.

Step 4: Shape shoulders. Bring forward 5 nds opp carriage to 'E' pos H.P. * on each row 14 times (35 sts on each shoulder). Using waste yarn, knit the centre back neck sts for a few rs. Remove from machine. Strip off the shoulders in waste yarn also.

BACK + FRONT (ST. STITCH)

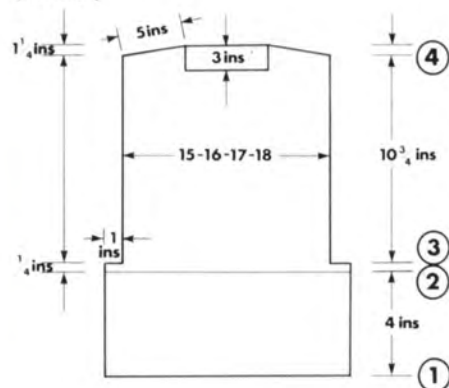

TOP DIAGRAMS

FRONT

Steps 1 and 2: As for back.

Step 3: RC 000. Knit without shaping to row 115. Divide for neck. Work on 35 sts nearest carriage, putting all others in H.P.

Step 4: Continue on 35 sts to row 130. Shape shoulder as for back and strip off in waste yarn.

Knit 35 sts on other side front to match. Strip off centre front sts in waste yarn, marking centre st with a scrap of contrast yarn.

Measurements

Top: To fit 32 (34, 36, 38) inch bust, 34 (36, 38, 40) inch hips.

Skirt: Length 32 1/2".

Materials

Hayfield Machine Knit, 2 cones (1 cone for top only or 1 cone for skirt only).

Tension

8 sts x 10 rs = 1" over lace TD6.

9 sts x 12 rs = 1" over st.st. TD5.

Card No. 426 Vol. 9, 820/830 set. Knit 8 rows st.st. points 28 & 56. Cast on

each part symmetrically either side centre of m/c.

BIB

Step 1: Using waste yarn, cast on 80 sts. Knit a few rs. TD5. Knit 9 rs. MDE. Hang 2 weights on waste yarn.

Step 2: RC 000. Knit in lace to row 096. Knit a few rs waste yarn, remove from m/c. Replace bib onto m/c with right side facing m/c placing 2 sts on each nd. Knit one row. Knit a few rs in waste yarn again and remove from m/c. Set aside.

NECKBAND AND BIB

Step 1: With right side facing m/c, attach bib above waste yarn to the centre 40 nds on m/c. Remove waste yarn.

Step 2: With right side facing attach front neck over bib, matching centre sts. Carefully pull forward the nds until the sts of the bib fall behind the latches, then pull through the sts of the front neck.

Step 3: Pick up 20 sts on each side front neck for band. Pick up sts of back neck above waste yarn.

Step 4: Knit 2 rs T5. Transfer every 3rd nd for 2 x 1 mock rib. Knit 9 rs reducing tension by one every row. Knit 9 rs increasing tension by one every

row. Bring forward empty nds. Knit 2 rs T5. Knit a few rs in waste yarn. Remove from m/c.

SLEEVES

Step 1: Using waste yarn, cast on 175 sts. Knit a few rs. Knit 9 rs T6 MDE. Hang 2 weights on waste yarn.

Step 2: RC 000. In lace knit to row 192 (200, 208, 216). Cast off. Knit 2 cords over 3 nds, T.O., each about 20" long.

TO MAKE UP

Graft neckband and shoulders. Join all other seams. Insert cords into holes of lower lace row of sleeves. Iron lightly, pressing out scallops of hem.

SKIRT

Materials, Measurements, Tension, Card: As for top.

Notions

1 metre narrow elastic

Panels

Knit 2, alter by 12 rs per inch if wished.

Step 1: Using waste yarn, cast on 175 sts. Knit a few rs. Knit 9 rs MDE, T6. Hang 2 weights on waste yarn.

Step 2: RC 000. In lace, knit 96 rs.

Step 3: RC 000. T5, knit 50 rs. Strip off in waste yarn. Replace onto m/c placing 2 sts on every 10th (12th, 14th, 16th) needle.

Step 4: RC 000, knit 100 rs. Strip off in waste yarn and replace as step 3.

Step 5: RC 000, knit 100 rs. Strip off in waste yarn and replace onto m/c, placing 2 sts on every 5th (6th, 7th, 8th) nd. Knit 23-rs * MDE picking up sts 12 rs above final set of waste knitting. (If you prefer, strip off at point * and graft hem for waistband.)

TO MAKE UP

Join seams and insert elastic.

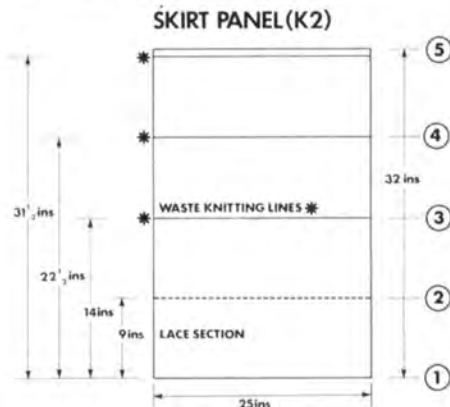
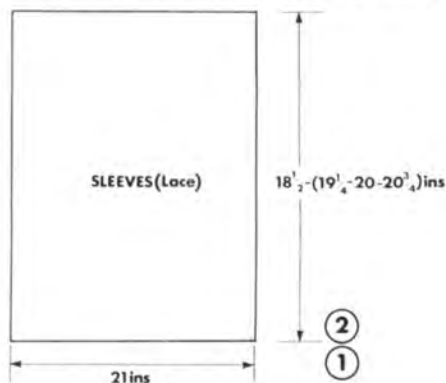

NEW



4 ply CLASSICS BOOK

from Vegas Yarns for only £1.35 (inc P&P)*

- * Containing a complete collection of classics for the whole family.
- * 'V' neck and round neck sweaters and cardigans with long or short, raglan or set in sleeves.
- * All sizes from 18" to 44" chest.
- * Suitable for all makes of machine.

Beginners and experienced knitters alike will appreciate this beautifully illustrated, simple to use, pattern book.

SEND TODAY Please allow 14 days for delivery.

To: Vegas Yarns Ltd., P.O. Box 60, Doyle House,
St. Peter Port, Guernsey, CI.
Please send me copies of your book
"Classic Knitwear" at per copy. I enclose
a cheque/PO made payable to Vegas Yarns for
£ p

From: Name
Address

Town Post Code
BLOCK CAPITALS PLEASE

* U.K. only. Overseas Prices per copy: Australia \$4.25 New Zealand \$4.50 U.S.A. & Canada \$4.50
All other countries at US \$ rate.

Lacy Shetland look

Measurements

To fit bust: 32/34 (36/38) ins.
length: 25 (26½) ins.
sleeve seam: 20 (21) ins.

Materials

Vegas 4-ply Wool/Acrilan - 1 cone -
small oddment of contrast.

Tension

28 sts x 36 rs = 4 ins. TD approx 8.
For 820 and 830 machines.

Notes

Using card No. 407, set No. 5 on rs 28
and 56. Knit 8 rs before using lace car-
riage.

BACK

Push up 124 (138) nds to W.P. Ar-
range in 2 x 1 rib. Cast on using waste,
knit a few rs. Carr at right knit in nylon
cord. Change to main yarn. TD4, RC
000, knit 30 rs. TD8, knit 1 row. TD4,
knit 30 rs. Turn up hem. TD8, knit 2 rs,
start lace carriage. Knit to row 126
(138). Cast off 13 sts beg next 2 rs.
Cont to row 198. Cast off.

FRONT

Knit as for back to row 170. Shape
neck: with short piece of main yarn,
cast off centre 18 sts. Knit nds at left
onto nylon cord leaving nds in A pos.
Make note of card row No. Working
on right, dec 1 st at neck edge on next
4 knitted rs. Dec 1 st at neck edge on
next and foll alt rs until 24 (38) sts
remain. R.C. reads 198. Cast off.
Repeat shapings for other side.

SLEEVES

Push up 120 nds to W.P. Cast on
using waste, knit a few rs. Carr at left,
knit in nylon cord. Change to main
yarn. TD8, RC 000, knit 2 rs. Start lace
carriage. Knit to row 152 (162). Work-
ing in st.st., knit 4 rs. Using contrast,



knit 4 rs. Using main yarn, knit 2 rs.
Using contrast, knit 4 rs. Using main
yarn, knit 4 rs. Cast off.

CUFFS

With wrong side of work facing push
up 60 nds, arrange in 2 x 1 rib, pick up
sts above cord. Placing 3 sts on each
needle, using main yarn, TD5, RC 000,
knit 1 row. TD4, knit 29 rs. TD8, knit 1
row. TD4, knit 30 rs. Cast off loosely.

NECKBAND

With right side of work facing, pick up
140 sts evenly round neck. TD8, knit 2
rs. Transfer st 2 x 1 rib. TD4, knit 10 rs.

TD3, knit 10 rs. TD2, knit 15 rs. TD8,
knit 1 row. TD2, knit 15 rs. TD3, knit 4
rs. Change to contrast. Knit 4 rs.
Change to main yarn. Knit 2 rs. TD4.
Change to contrast. Knit 4 rs. Change
to main yarn. Knit 7 rs. Push forward
nds in A pos. TD8, knit 4 rs. Change to
waste yarn. Knit few rs. Release from
machine.

TO MAKE UP

Join shoulders, side and sleeve
seams. Fold cuffs to inside of work
and slip st down. Fold neckband to
outside and backstitch into loops.
Press with warm iron.

SAILOR TOP

Materials

Lister/Lee Target Conifer

1 con Col. A

Oddment Col. B

Measurements

To fit 24 26 28 in. chest

Total length 17-19½-20 inches

Sleeve seam 11-12½-13½ inches

Tension

8 sts × 11½ row = 1 in.

T.D. approx 6

Stars from charts



BACK

Step 1. Col. A C.O.B.H. 104 112 120 sts., T4. K15 rows, T6 K1 row T4 K15 rows T4 T6 K1 row C.O.R. 000.

Step 2. K4 rows Col. A, 2 rows Col. B, 4 rows Col. A, 2 rows Col. B, 4 rows Col. A, 2 rows Col. B, cont in col. A to row 110 138 140, cast off 4 sts. at beg. of next 2 rows. 000.

Step 3. Dec. 1st at both ends every alt. row. 6 8 8 times to 84 88 96 sts. K to row 66 70 72.

Step 4. Cast off 5 sts. at beg. of next 4 2 0 rows, cast off 6 sts. at beg. of next 4 6 4 rows, cast off 7 sts. at beg. of next 0 0 4 rows Cast off rem. 40 42 44 sts.

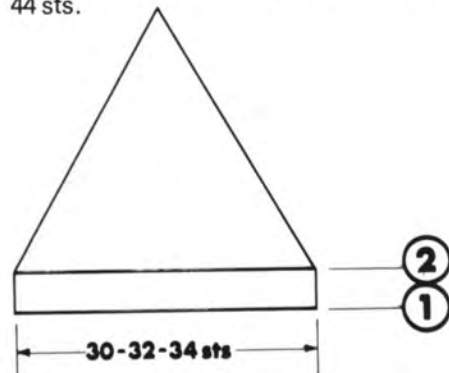

Front

Knit as for back to end of Step 2.

Step 3. Dec. centre 2 sts. (one to left, one to right) working on right side only. Shape right edge (armhole) as for back at the same time dec. 1st at neck edge every 3rd row 13 13 15 times, then every 4th row 6 7 6 times to row 66 70 72, cast off 5 sts. at beg. of next 2 1 0 alt. rows, 6 sts. next 2 3 2 alt. rows, 7 sts. next 0 0 2 alt. rows. Complete left side to match rev. all shaping.

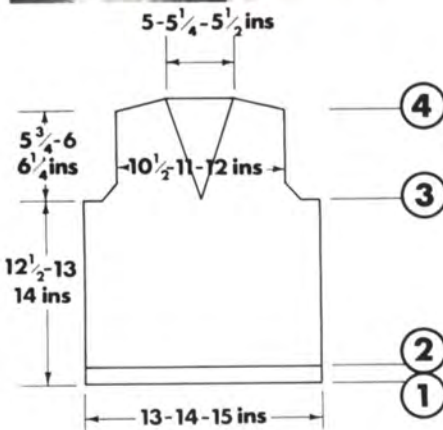

Sleeve

Step 1. Col. A. C.O.B.H. 66 68 70 sts. knit as for Step 1 of back. 006.

Step 2. Knit stripe sequence as on back, inc. 1st at both ends every 12 13 14th row 9 10 11 times to 84 88 92 sts. K to row 126 144 156. Cast off 4 sts. at beg. next 2 rows. 000.

Step 3. Dec. 1st at both ends every alt. row 18 20 22 times. Dec 1st at both ends every row 10 times, cast off 3 sts. at beg. of next 4 rows. Cast off rem. 8 sts. Press all pieces. Join shoulder seams.

GOLD EVENING DRESS

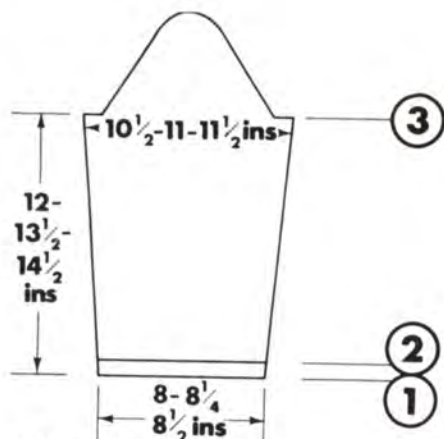

Collar

Step 1. In col. B. C.O.B.H. 80 84 86 sts. T4 Inc. 1st at beg. of next 10 rows. T6 K1 row. T4 Dec. 1st at beg. of next 10 rows, T4 Col. B. T6 K1 row 000. C.O.R.

Step 2. K8 rows, knit 2 stars, 8 nds. in from each end by hand selection. Cont. in col. A K to row 50. Cast off centre 40 42 44 sts. 000.

Step 3. Cont. on right side only K8 rows, Dec. 1st on inside edge every 4th row 6 7 6 times then every 3rd row 14 14 16 times until all sts. are dec. Knit right side to match rev. shapings.

Bands

C.O.B.H. in Col. B 65 67 68 sts. T.4 inc. 1st at beg. of next 10 rows. T6 K1 row T.4 Dec. 1st at beg. of next 10 rows. T.H. with right side of work facing m/c. Place one outside edge of collar to these sts. cast off, Rept. for other edge of collar. Press.

Insert

Step 1. C.O.B.H. in col. B. 30 32 34 T.4 K10 rows, T.6 K1 rows, T4 10 rows, T.H. T.6 K1 row.

Step 2. K2 rows ★ Col. A. K2 rows, Col. B K4 rows ★ rept. from ★ to ★ throughout at the same time dec. 1st at both ends every 3rd row 12 13 14 times. Cast off rem. 6 sts. Press.

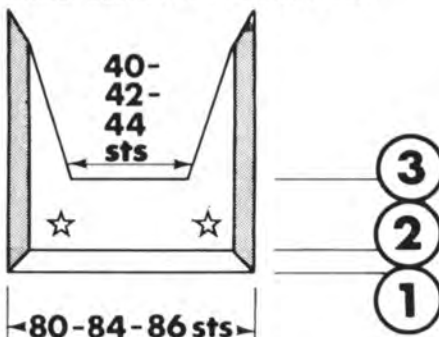

TO MAKE UP

Join edges of collar to neck edge. Join band ends. Sew in insert, sew in sleeves. Join rem. seams.

Measurements

To fit bust: 81cm (32"), 86cm (34"), 91cm (36"), 97cm (38")

Materials

10 cones of White Gold Silverknit from: Silverknit, The Old Mill, Eppers-ton By-Pass, Woodborough, Nottingham NG14 6DH.

Tension

Always check tension before commencing.

T10 over st.st. 40 sts = 13.5cm and 60 rs = 16cm.

BACK (left)

With W.Wl. cast on 102 (106, 110, 114) sts. Knit a few rs. Change to M.Wl. T9. Knit 20 rs. Turn up hem and knit the row. T10, knit 1 row. RC 000, knit 1 row. Carr on left, put 62 (65, 68, 71) nds on right into H.P. Knit 2 rs * push back 7 nds into W.P. Knit 2 rs. * Rep 6 times more. Set m/c to N. Knit 1 row. Carr to right. Dec 1 st on right on next and ev foll 5th row until 61 (65, 69, 73) sts rem. Knit to row 220. Dec 2 sts at beg of next row and dec 2 sts at right on ev foll 5th row 7 times. Knit to row 258. RC 000 *

Inc 1 st at right on next and ev foll 4th row until inc'd to 54 (58, 62, 66) sts. Knit to 38 rs. Carr to left. Cast off 30 (34, 38, 42) sts at beg of next row. Knit 1 row. Cast off 3 sts at beg of next row and ev foll 2nd row 9 times. Knit 1 row. Cast off rem sts.

BACK (right)

Knit to match left side reversing all shapings.

FRONT (left)

Knit as back to *. Inc 1 st on right on next and ev foll 4th row until inc'd to 60 (64, 68, 72) sts. Knit to row 38. RC 000. At right side dec 2 sts ev 2nd row and at left side dec 2 sts ev 3rd row. Work these 2 shapings tog until 3 sts rem. Cast off.

FRONT (right)

Knit to match left side reversing all shapings.

BELT

Make cord over 4 sts. Knit to required length.





HOME FURNISHING

Co-ordination seems to be very much a word of the moment as can be seen on every dress rail. However that's not where the story ends. The co-ordinated look has found a place in our homes too. It started with matching wallpaper and curtains and now even crockery is produced with the same print as the tablecloth and napkins.

There are two totally different looks around; one is the fine and fussy look – almost Victorian in flavour – the other follows on from the sleek Scandinavian look, where the natural characteristics of wool, cotton, leather, wood and pottery are the main feature.

I have recently restored a small cottage and after having finally hung up my overalls I found myself very short of cash and with a lot of odd – lovely but no way co-ordinating – furniture. Nothing matched at all so I decided to get out my trusty knitting machine and design some soft furnishings that are easy to make, easy on the purse and easy on the eye. I wanted each room to be comfortable, have a total look but be homely and interesting.

The fashion story has been lace, lace and more lace and now that too has moved into home furnishings; bedspreads, curtains, lampshades, cushion covers, everything. I hope your machine is set up listening to all this!

I'm very fond of lace so when I found myself with a lot of lampshades the wrong colour and size, I stripped them to the frame and recovered them. Now I have lampshades of different sizes and shapes but matching! One of my efforts you see before you. It doesn't take very long to knit and being made of 100% cotton can be taken off the frame and washed easily.

It would look especially well in the bedroom but don't exclude the dining room or even the bathroom.

If the fussiness of lace doesn't appeal, try something woven. The woven cloth produced on the knitting machine is more firm than the other fabrics and lends itself very well to furnishings. Weaving is a very interesting way of using up wool oddments too. I have designed a large woven cushion which seems to be loved by all. Every small child that comes into the house makes a B-line for it (see pattern).

In the dining room seat covers look very well woven and if your chairs are like mine and not all the same set, it will bring them together and give the appearance that they do belong together. Why not have placemats to match?

The possibilities are endless, a rug for the bedroom, wall hangings and throw-pillows for the lounge, curtains etc. All these things are fun to do and will add a touch of luxury and individuality to your home.

With so much mass-production around us most people prick up their ears at the mention of something home-made and I'm no exception. Generally there is a move towards individually made goods – why not jump on the bandwagon? Natural fibres are coming very much into their own again as their quality is appreciated more and more. The natural yarns can sometimes be a little more expensive but their quality lasts and lasts. A little time and effort now might well provide an heirloom for your family.

In future issues I shall be sharing some more ideas with you so don't rush out and buy anything unless it's yarn!

CUSHION Measurements

75cm x 75cm.

Materials

Mailyarns Ltd., 38 High Street, Syston, Leicester, LE7 8GP.
Shetlandia – a small amount from four different coloured cones.

Tension

Always check tension before commencing.

T4 40 sts = 15cm and 60 rs = 12cm.

Notes

Card from basic pack 6 D. Weaving thread is made up from 2 ends of Shetlandia.

Pattern

Made up from four colours: white, camel, brown, black. 10 rs camel woven on black, 10 rs brown woven on white, 10 rs white woven on camel.

CUSHION COVER

Top: Insert card and lock on row 1. C.O.B.H. 200 sts T4 in black. Knit 4 rs. Carr to left, set machine for weaving. Carr to right release card. (Weave camel onto black, foll patt.) Dec 1 st at each end of next and ev foll 2nd row until row 126. Change to white woven on white. Cont dec until 76 sts rem. RC 000. *

Change to white woven on white and knit 128 rs. RC 000. Inc 1 st at beg of next 2 rs and ev foll row to row 4, then cont in pattern reversing to match first side. Cont inc to 200 sts, change to st.st. Knit 6 rs, cast off.

Sides: Work in the same way as top until * then cast off. Rep.

Work underside in same way or cast on 200 sts and weave 376 rs in the combination of your choice.

Press all pieces, join seams.

LAMP SHADE

Measurements

To make 12 inch lampshade – see photo for shape.

Materials

Mailyarns Ltd., 38 High Street, Syston, Leicester, LE7 8GP.
Bancot 2-ply cotton. Small amount from 200g cone.

Tension

Always check tension before commencing.

T8 40 sts = 14cm and 60 rs = 16.5cm.

Notes

Card used from Jones Big and Bold pack, punch card set Vol. 5 Card No. 409.



With W.WI. cast on 60 sts. Knit a few rs. Change to M.WI. T8. Knit 2 rs. Insert card and lock on row 1.

* Release card and work in lace to 10 rs in st.st. Knit 3 rs. Put 30 sts on right into H.P. (Knit 2 rs. Starting from left

push 6 nds into W.P.) Rep until all nds are in W.P. Knit 3 rs. * Rep 11 times more except on last plain (st.st.) panel only knit 1 row after all nds are in W.P. Change to W.WI. and knit a few rs. Release from machine. Pin out and

press. Undo W.WI. and graft seam. Put onto frame and thread elastic through top and bottom, pull tight and join.

Make a row of tassels along base edge.

BOYS FAIRISLE SWEATER

Measurements

Age 5-6 years, 7-8 years, 9-10 years
To fit chest 61cm (24"), 66cm (26"),
71cm (28")

Materials

1 (1, 1) 250g cone Lister/Lee Target
Conifer machine knitting yarn. 60%
wool, 40% nylon. Col A.

1 (1, 1) 250g cone Lister/Lee Target
Conifer machine knitting yarn. 60%
wool, 40% nylon. Col B.

Tension

30 sts and 42 rs = 10cm measured
over st.st. TD approx 6.

Pattern Sequence

Patt as diagram. Knit 2 rs col B, knit 4
rs col A, knit 2 rs col B, 4 rs col A, set-
ting m/c for fairisle. Release card, and
with col A in main feed knit 20 rs in
fairisle patt locking patt card on final
row in preparation for next row of fair-
isle. These 32 rs form patt. Patt can be
worked on 8, 12 and 24 st repeat
m/c's.

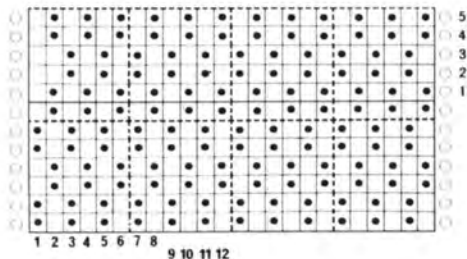

BACK

Step 1: Insert patt card and lock on
row 1. With waste yarn cast on 110
(116, 122) sts for 1 x 1 mock rib, work a
few rs waste C.O.L. Change to col A
and work 20 rs T4, 1 row T5, 20 rs T4.
Turn up hem and remove waste yarn.

Step 2: RC 000. TD6, C.O.R. Now
work in patt to row 112 (114, 116). Put
markers at each end of row 168 (172,
176).

Shoulder Shaping

Cast off 9 (9, 10) sts at beg of next 6 (4,
8) rs. Now cast off 10 (10, 0) sts at beg
of next 2 (4, 0) rs. Place rem 36 (40, 42)
sts on waste yarn.

FRONT

Step 1: Cast on 110 (116, 122) sts and
work as for back.

Step 2: Work as for back to row 112
(114, 116). Put markers at each end of
row. Knit 2 rs straight C.O.R. (N.B.
pos of patt card.)

Knit sts by hand onto nylon cord into
N.W.P. to left of centre 0. (N.B. it is
sometimes helpful to put a piece of
'sellotape' in front of nds in N.W.P. to
keep them in this pos whilst knitting
first side.)

Now work right front by dec 1 st at
neck edge on every alt row 11 (12, 13)
times, then on every 4th row until 37
(38, 40) sts rem. Work straight to row
168 (172, 176).

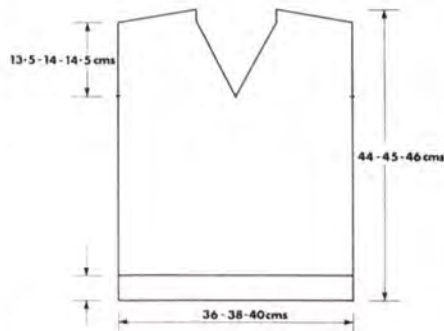

Shoulder Shaping

Cast off 9 (9, 10) sts at beg of next 3 (2,
4) alt rs. Now cast off 10 (10, 10) sts at
beg of next 1 (2, 0) alt rs. Work rem sts
as for right front.

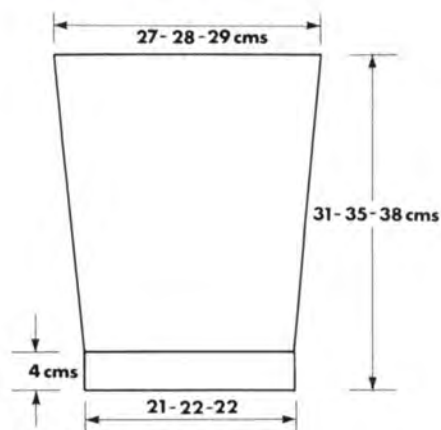

SLEEVES

Step 1: With waste yarn cast on 52
(54, 56) sts for 1 x 1 mock rib and work
as for back.

Step 2: RC 000. Work as for back *at
the same time* inc 1 st at each end of
next and every foll 7 (8, 9)th row 15
times in all. 82 (84, 86) sts. Work
straight to row 108 (124, 136), work 6
rs col B. Cast off loosely.

MAKING UP AND NECKBAND

Block out each piece and press with a
warm iron and damp cloth. Join right
shoulder seam.

Push 79 (85, 89) nds into W.P. With
right side of work facing m/c replace
sts onto m/c as follows:

36 (40, 42) sts from back neck 43 (45,
47) sts from front V-neck. C.O.R.
TD4, knit 1 row, set for 1 x 1 mock rib,
TD4. Work 6 rs col A, 2 rs col B, TD5,
1 row col B, TD4, 2 rs col B, 6 rs col A.
Pick up sts to form hem. Cast off
loosely.

Push 43 (45, 47) nds into W.P. Now
work as for right neck band.

Join left shoulder. Sew in sleeve be-
tween markers. Join side and sleeve
seams. Join V-neck at centre. Give a
final light press.



GIRLS SHIRRED DRESS



Measurements

Age 3 - 4 years approx.
To fit 22 (24) inch chest.
16 (18) ins length from underarm to hem.

Materials

Phildar Contraste 049 5 (5) 50gr balls.
2 spools of shirring elastic.

Tension

6 sts x 11 rs = 1". TD8 over st.st.
M/cs: All m/cs capable of weaving.
Patt: 2 row patt.



820, 830 m/cs: Insert card 1 of basic set and leave card locked throughout.

Notes

To alter length, alter 2 by 11,rs for each inch. Dress may be used as a skirt by removing straps when outgrown.

Sufficient yarn remains to knit slippers.

FRONT AND BACK ALIKE

(Knit 2 pieces)

Step 1: Cast on 150 (156) sts with cast on row arranged over alt nds. TD6. After making cast on, bring forward the empty nds, (150, 156) sts TD8. Knit 8 rs. TD8, knit 1 row. T10, knit 10 rs, TD8. MDE placing loops on every alt nd.

Step 2: RC 000. Knit 120 (132) rs.

Step 3: Set m/c for patt. Engage weaving brushes. Set RC 000. Using the elastic double, lay this over the nds without stretching the thread. Knit the row slowly, then pull the thread until

LACE WAISTCOAT

you see it pull against all the nds. Knit another row with the elastic woven in. Knit 4 rs st.st.

Repeat step 3 until you have 6 (7) sets of shirring. RC 036 (042).

Step 4: Knit 2 rs st.st. Transfer every alt nd for picot edge. Knit 4 rs. Transfer every alt nd pushing empty nds to A pos. Knit 1 row T6. Knit a few rs waste yarn, remove from m/c.

STRAPS (knit 2) III • I • III

C.O.B.H. TD6. Formation * Knit 2 rs. Engage H.P. Bring forward 2nd, 5th, 8th nd to H.P. Knit 4 rs. Push back these nds slightly. Repeat from * to make 28 (30) 'shells'.

TO MAKE UP

Secure ends of elastic. Catch down loosely the top hem, join side seams. Attach straps.

SLIPPERS

Measurements

To fit over tights. Shoe size approx. 6-7 (8-9)

Materials

Phildar Contraste 049. 1 50gr ball. 1 spool shirring elastic (used double).

Tension

9 rs x 7 sts = 1" over st.st. TD8.

M/cs: As for dress.

Step 1: Cast on 46 (48) sts. Knit 3 rs TD8. Knit one row TD10. Knit 4 rs TD8 MDE. Knit one row to set patt. Engage wearing brushes.

Step 2: *Stretch elastic over nds. Knit 2 rs with elastic. Knit 2 rs st.st. Repeat from * twice.

Step 3: Knit 10 (12) rs st.st.

Step 4: Divide work. Remove half the stitches on a few rs waste yarn. Knit one row to return nds in H.P. to working pos.

Step 5: H.P. Bring to E pos 7 (8) sts opp carr. Knit one row. Bring to E pos 7 (8) sts opp carr. Push back the inside nd (nearest centre of heel) on each row which is opp carr. Continue until all nds are back in working pos.

Step 6: Knit 36 (38) rs.

Step 7: H.P. Bring to E pos 9 (10) sts and knit as for step 5 until all nds are back in working pos.

Step 8: Knit 30 (32). Knit a few rs waste yarn. Remove from m/c.

TO MAKE UP

Graft seam above waste yarn. Join side leg and foot seams, securing elastic. Insert a double length of shirring elastic in top hem.

Measurements

To fit bust: 81cm (32"), 86cm (34"), 91cm (36"), 97cm (38").

Materials

Jamieson & Smith (SWB) Ltd., 90 North Road, Lerwick, Shetland Isles, ZW1 OPQ.

Lace weight (2-ply) 4 hanks.

Tension

Always check tension before commencing.

T6 40 sts = 15cm and 60 rs = 14cm. (Success depends on working to correct tension.)

Notes

Card used from Jones Big and Bold pack, punch card set Vol. 5. Card No. 407.

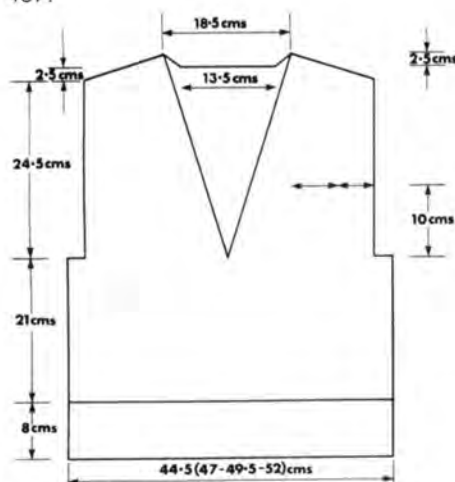

BACK

Insert card and lock on row 1. With W.WI. cast on 116 (122, 128, 134) sts as 2 x 1 mock rib. Knit a few rs. Change to M.WI. T5. Knit 60 rs. Turn up hem and knit the row. Release card and work in lace. Knit 88 rs or required length. Cast off 6 sts at beg of next 2 rs. Knit to row 192. RC 000.

Shoulder Shaping

* Cast off 4 (4, 5, 5) sts at beg of next 2 rs. Knit 1 row *. Rep these 3 rs twice more. Cast off centre 34 sts. Put left

side of work onto W.WI. and release from machine (make note of card pos). Working on right side only, cont shoulder shaping at same time as cast off 3 sts ev 2nd row at neck edge. Work these two shapings together until 6 sts rem. Cast off. Work other side to match reversing all shapings.

FRONT

Insert card and lock on row 1. With W.WI. cast on 116 (122, 128, 134) sts as 2 x 1 mock rib. Knit a few rs. Change to M.WI. T5. Knit 60 rs. Turn up hem and knit the row. Release card and work in lace. Knit 88 rs or required length.

Cast off 6 sts at beg of next 2 rs. RC 000. Put left half of work onto W.WI., release from machine (make note of card pos), dec 1 st at neck edge ev 5th row. Work to row 102 then work shoulder shaping as back at same time as dec for front neck shaping.

Join shoulder seams. Mark centre back neck.

ARMHOLE EDGE

Cast on 130 sts in W.WI. Knit a few rs. Change to M.WI. T5. Knit 30 rs. Turn up hem. Pick up 130 sts along armhole edge and place onto nds. Cast off. Work other side to match.

NECKBAND

Cast on 200 sts in W.WI. Knit a few rs. end of next and ev foll 2nd row 6 times. Knit 2 rs. Turn up hem. Starting from right pick up sts along neck edge from centre front to centre back with wrong side of work facing. Cast off these sts leaving the last 5 sts. Pick up the sts along neck edge from centre back to centre front, place onto nds and cast off.

Change to M.WI. T5. Knit 2 rs. Dec 1 st at each end of next and ev foll 2nd row 6 times. Knit 2 rs. Inc 1 st at each

MAKE UP

Press and join rem seams.



Boys Chunky Jumper

Measurements

Age 5-6 years, 7-8 years, 9-10 years
To fit chest 61cm (24"), 66cm (26"),
71cm (28")

Materials

1 (2, 2) 250g cones of Lister/Lee Target Acrylic/Nylon Conifer machine knitting yarn.

Tension

30 sts and 44 rs = 10cm measured over st.st. TD approx 6.

24 sts and 80 rs = 10cm measured over Tuck patt. TD approx 6.

Notes

Due to differences in Tension, width is added where the reverse st.st. yoke begins, by moving sts out. Extra weights may be needed for this extra 'springy' yarn. Tuck patt can be worked on 8, 12 and 24 sts. Repeat m/cs.

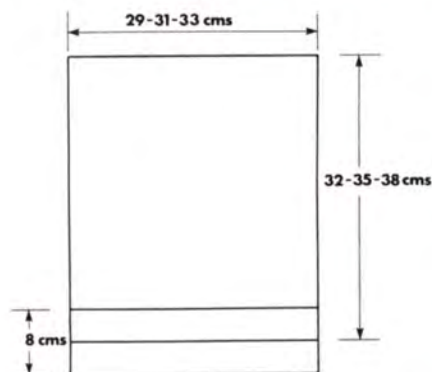
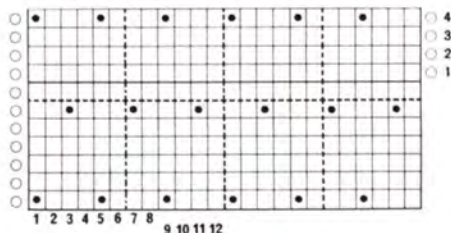

BACK

Step 1: Insert patt card and lock on row 1. With waste yarn cast on 86 (92,



96) sts, set for 1 x 1 mock rib and work a few rs. C.O.R. Change to main yarn and work 20 rs TD5, 1 row TD6, 20 rs TD5. Turn hem and remove waste yarn.

Step 2: TD6 knit 1 row setting m/c for tuck st. patt. RC 000. C.O.R. Depress both tuck buttons and work straight in patt to row 188 (196, 204). Put markers at each end of row. Cont straight in patt to row 199 (215, 231). Set m/c for plain knitting and work 1 row. C.O.R.

Step 3: Increase 10 sts on each side of knitting. This can be done by stripping off with waste yarn, and then replacing work onto 106 (112, 116) nds or moving sts out evenly with transfer tool. 106 (112, 116) sts.

Step 4: RC 000. Work straight in st.st. for 66 rs.

Shoulder Shaping

Cast off 8 (9, 9) sts at beg of next 6 (8, 6) rs. Now cast off 9 (0, 10) sts at beg of next 2 (0, 2) rs. Cast off rem 40 (40, 42) sts.

FRONT

Work steps 1-3 as for back.

Step 4: RC 000. Work 2 rs straight in st.st.

Divide for neck

Put 65 (68, 70) nds to left in H.P. Now shape left neck by dec 1 st at neck edge on every foll 6th row 1 (1, 5) times. Now on every foll 8th row until 33 (36, 37) sts rem. Work 2 rs straight (66 rs).

LADIES ADD TO SET

Polo Neck Sweater

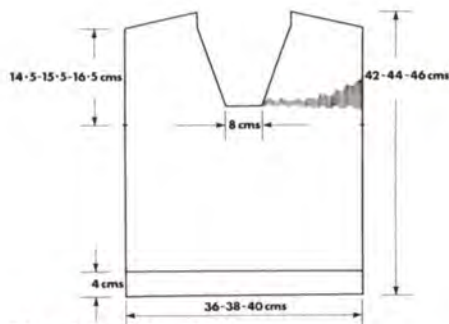

Shoulder Shaping

Cast off 8 (9, 9) sts at beg of next 3 (4, 3) alt rs. Cast off rem 9 (0, 10) sts.

Right Front

RC 002. Work as for left. Cast off centre 24 sts.

SLEEVE

Step 1: Insert patt card and lock on row 1. Set for 1 x 1 mock rib. With waste yarn cast on 70 (74, 78) sts, and work a few rs waste ending with C.O.R. Change to main yarn and work 40 rs T5, 1 row T6, 40 rs T5. C.O.L. Turn up hem and remove waste yarn.

Step 2: TD6. Knit 1 row setting m/c for tuck st. patt. RC 000. C.O.R.

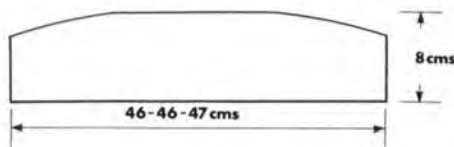

Depress both tuck buttons and work straight in tuck st for 223 (247, 271) rs. Set m/c for plain knitting, knit 1 row. Cast off very loosely.

MAKING UP AND COLLAR

Join shoulder seams.

COLLAR

With main yarn. TD4.

Step 1: Cast on 156 (156, 160) sts. Knit 2 rs. Set for 1 x 1 mock rib.

Step 2: Put 4 nds at opp end to carr into H.P. and knit 1 row catching yarn under last needle in H.P. to prevent a hole forming. Repeat step 2, 7 (7, 9) more times. Now put 3 nds at opp end to carr into H.P. and knit 1 row 4 (4, 2) times. Push nds to left into W.P. Knit 1 row, put rem sts into W.P. and knit 1 row.

Step 3: Work straight to row 86. Now repeat step 2.

Step 4: Pull alt nds in N.W.P. forward into W.P. Knit 1 row. TD6. Bring up cast on edge to form hem. Knit 1 row. Cast off loosely.

Sew in sleeves between markers. Sew in collar crossing at the front. Join side and sleeve seams. Give a very light press with warm iron and dry cloth.

Measurements

To fit 34, 36, 38 inch bust.
Total length: 24½, 25, 25½ ins.
Sleeve Seam: 17 ins.

Materials

1 Cone Hayfields 3-ply Machine Knit.

Tension

8 sts x 11½ rs = 1 inch over st.st.
TD approx 4.

BACK

Step 1: Ribbers: Cast on for 1 x 1 rib 133 (141, 149) sts. T 4/4, knit 40 rs. 000. S/bed m/c: Cast on for 1 x 1 mock rib 133 (141, 149) sts. T2, knit 70 rs. Turn hem. 000.

Step 2: T4, inc 1 st at both ends every 35th row 4 times to 141 (149, 157) sts. Knit to row 150. Cast off 4 sts at beg of next 2 rs. 000.

Step 3: Dec 1 st at both ends every 3rd row 6 (8, 10) times to 121 (125, 129) sts. Knit to row 86 (92, 98).

Step 4: Cast off 10 sts at beg of next 6 rs. Cast off 9 (11, 13) sts at beg of next 2 rs. Place rem 43 sts on to waste yarn, for back neck.

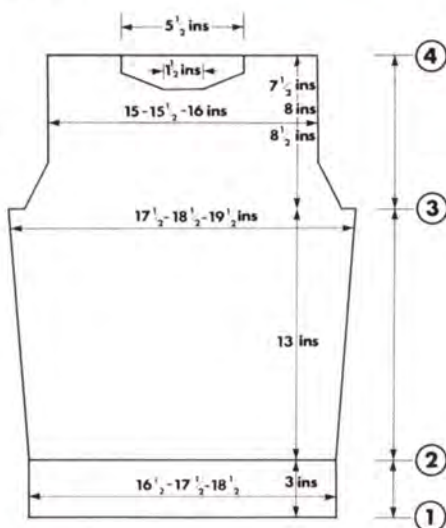

FRONT

Knit as for back to row 68 (74, 80) of step 3. Place centre 15 sts on waste yarn and continue on right side only leaving sts to left in H.P. Push 1 st into H.P. at neck edge every row 14 times.

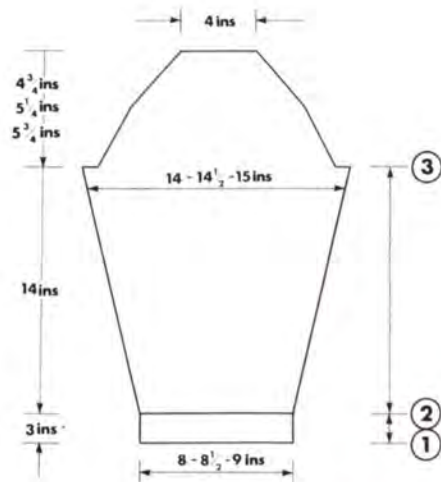

Knit to row 86 (92, 98). Cast off 10 sts at beg of next 3 alt rs. Cast off rem 9 (11, 13) sts.

Work left side to match, placing sts from H.P. on waste yarn.

SLEEVES

Step 1: Cast on 65 (69, 73) sts. Work as for step 1 of back. 000.

Step 2: Inc 1 st at both ends every 6th row 23 times to 111 (115, 119) sts. Knit to row 170. Cast off 4 sts at beg of next 2 rs. 000.

Step 3: Dec 1 st at both ends every 3rd row. 0 (0, 2) times, then every alt row 18 (22, 22) times, then every row 2 (0, 0) times (38, 44, 50) rs. Cast off 2 sts at beg of next 16 rs. Cast off rem 31 sts.

TO MAKE UP

Press all pieces excluding rib.

NECK

Ribbers: Cast on for 1 x 1 rib 121 sts. T 4/4, knit 60 rs. Trans to main bed.

S/bed m/c: Cast on for 1 x 1 mock rib 121 sts. T2, knit 110 rs. Turn hem. With right side of work facing m/c, place sts from back neck to 48 sts of collar spacing in extra sts evenly, place front neck to rem 73 sts easing in extra sts evenly, cast off loosely.

Join shoulder seams and collar seam. Sew in sleeves. Join sleeve and side seams.



STOCKISTS LIST – KNITTING MACHINES

BEDS

Bedford Sewing Machines, 13 Lime Street, Bedford.
Knit 'N' Sew, 20 Market Square, Leighton Buzzard.

BERKS

Knitting Machine Centre, 54 London Street, Reading.
Boswood & Hendry, 3 West Street, Reading.
Stagport, 48 Wellington Street, Slough.

BUCKS

Boswood & Hendry, 239 High Street, Slough.

CHESHIRE

Knit & Sew, Unit 13, Tontine Market, St. Helens.
Wollengers, 91 Oldham Street, Manchester.
Woolsave, Woodchurch Road, Birkenhead.
Northern Sewing Machines, 102 Princess Street, Stockport.
Wollengers, 19 Paddock Road, Chester.
Owen, Owen Ltd., Eastgate, Chester

CORNWALL

The Fabric Centre, 30 Fore Street, Chase Water, Truro.
Roseland Sewing Machines, 1 West End, Redruth.

CUMBRIA

Knitting & Sewing Centre, Vulcans Lane, Workington.
Sewknit, 25 Globe Lane, Carlisle.

DERBYSHIRE

Sew-knit, 202 Burton Road, Derby.
Hal Ainsworth, 13-15 Beetwell Street, Chesterfield.

DEVON

Plymouth Knitting Machine Specialists, 6 Beaumont Street, Plymouth.
North Devon Sewing Machines, 68 Clovelly Road, Bideford.
The Wool Pack, 22 Anstis Street, Plymouth.
Joyce Wools, 19 Highweek Street, Newton Abbot.
Barnstaple Sewing Machines, Holland Street, Barnstaple.
Bideford Knitting Centre, Grenville Street, Bideford.

DORSET

Metropolitan Sewing Machines, 321 Ashley Road, Parkstone, Poole.

DURHAM

Marjories Wool Shop, 22 Moor Lane, Harton Village, South Shields.

ESSEX

Modern Knitting Machines, 14a Baddow Road, Chelmsford.
Franklin & Sons, 58 Head Street, Colchester.
Letsalknit, 682 Green Lanes, Ilford.
Machine Knits, 55-57 Hamlet Court Road, Westcliff-on-Sea.
Rayleigh Knit-in, 54 Eastwood Road, Rayleigh.

GLOUCESTERSHIRE

Cotswold Sewing Machines, Lansdown Road, Stroud.

HAMPSHIRE

The Knitting Basket, 38 Pylewell Road, Hythe, Southampton.
Sewing Machines Supplies, 131-133 Fratton Road, Portsmouth.
Metropolitan Sewing Machines, 130 Commercial Road, Bournemouth.
Needlecraft, 6 Hippodrome House, Aldershot.
Trendy Trims, 5 High Street, Ryde, Isle of Wight.
Ryde Wool Shop, 14 High Street, Ryde.
Woolco Limited, The Hampshire Centre, Castle Lane, Bournemouth.

HEREFORDSHIRE

Sewing Centre, 13 Commercial Road, Hereford.

HERTFORDSHIRE

Woolco Limited, Hatfield.

KENT

Weaver Knits, 276 Main Road, Sutton at Home, Nr. Dartford.
Knitting Machine People, 36 Windsor Avenue, Cliftonville.
Maidstone Sewing & Knitting Centre, 65 Upper Stone Street, Maidstone.
Canterbury Sewing Centre, 26 St. Peter Street, Canterbury.
The Wool House, 62 High Street, Rochester.

LANCASHIRE

T & M Grundy, 292 Manchester Street, Oldham.
R & T Sewing Machines, 269 Accrington Road, Blackburn.
Ann's Wools, 4 Inglewhite Road, Longridge.
Owen, Owen Limited, Clayton Square, Liverpool.
Lewis's Limited, Ranelagh Street, Liverpool.
Woolco Limited, The Arndale Centre, Middleton.
Lewis's Limited, Market Street, Manchester.
Dalby & Jones, 73 Church Street, Preston.

LEICESTERSHIRE

Sew-knit, 282 Humberstone Road, Leicester.
Woolco Limited, Leicester Road, Oadby Frith, Leicester.
Lewis's Limited, Humberstone Gate, Leicester.

LINCOLNSHIRE

Knitting Machine Centre, 276 Ashby High Street, Scunthorpe.
The Wool Shop, Red Lion Street, Spalding.
Co-op Limited, Silver Street, Lincoln.
Tudor Wool Shop, 4 Eastgate, Louth, Lincs.

LONDON

The Wool Shop, 95 Broadway Market, Tooting, SW17.
Lindaville, Wood Green Shopping City, 120 High Road, Wood Green, N22.
Wimbledon Sewing Machines, 216 Merton High Street, SW19.
The Wool Shop, 103 High Road, Chiswick, W4.
Chingford Knitting Machine Centre, 30 Kings Head Hill, E4.
Selfridges, Oxford Street, W1.
Quicknit, 344 Barking Road, Plaistow, E13.
London Co-op Limited, 78-102 The Broadway, Stratford, E15.
Sewcraft Sewing Machines, 150 King Street, Hammersmith, W6.
Cricklewood Sewing Machines, 166 Cricklewood Lane, NW2.
Fenwicks Limited, Brent Cross Shopping Centre, NW4.

MIDDLESEX

Stitches, 20 Fillebrook Avenue, Enfield.

NORFOLK

Central Norfolk Knitting Machine Co, 16 Church Street, East Dereham.
Sew-Knit Centre, 20 St. Benedicts Street, Norwich.

NORTHUMBERLAND

John Farnon Limited, Non Street & Newgate Street, Newcastle.

NOTTINGHAM

Jessops Stores, Victoria Centre, Nottingham, NG1 5QP.
Sew-Knit, 14 Trinity Walk, Trinity Square.
Hucknall Sewing Centre, 43a Watnall Road, Hucknall.

NORTHAMPTONSHIRE

Bedford Sewing Machines, 36 St. Giles Street, Greater Peterborough Co-op Soc., Park Road, Peterborough.

ORKNEY

Dudley Kynock, 31 Buttquay Crescent, Kirkwall.

OXFORDSHIRE

Sewing Machine & Fabric Centre, 86 London Road, Headington.

SUFFOLK

Franklin & Sons, 14-16 Crown Street, Ipswich.

SUSSEX

Shoreham Knitting Machines, 26 Brunswick Road, Shoreham By Sea.
Sewing Machine Supplies, 65 London Road, Bognor Regis.
Knitters Corner, The Broadwalk, Crawley.

SURREY

Wimbledon Sewing Machines, 1 Friary Street, Guildford.
Sew-Fashions, 14 The Broadway, Woking.
Superknit, 7 Thornton Road, Thornton Heath.
Corner Wool Shop, 15 Corner House Park, Epsom Road, Ewell.
Bentalls Limited, Kingston upon Thames.
Wimbledon Sewing Machines, 1 West Street, Dorking.

STAFFORDSHIRE

Domestic Sewing Services, 18 Walsall Road, Cannock.
Lewis's Limited, Hanley, Stoke on Trent.

SOMERSET

B & L Bontoft Ltd., 37 St. Johns Street, Bridgewater.
Denners Limited, High Street, Yeovil.
Bredons Sewing Machines, 3 Eastgate Street, Taunton.

SHROPSHIRE

K. N. S. 204 Whitchurch Road, Shrewsbury.
Knitting & Sewing Centre, 64 Upper Road, Meole Brace, Shrewsbury.

TYNE & WEAR

Woolco, Killingworth.
Woolco, The Washington Centre, Washington.

WARWICKSHIRE

Lewis's Limited, 32 Bull Street, Birmingham.
Co-op Limited, 27-38 High Street, Birmingham.
Wingfield Sewing Machines, 38 Birmingham Road, Birmingham.
Owen, Owen Limited, Broadgate, Coventry.
Bonnies Wools, 1273 Bristol Road South, Northfield, Birmingham.
Fabric Gallery, 15 Drury Lane, Solihull.
Sew-knit, 120-122 Corporation Street, Birmingham.

WILTSHIRE

Cotswolds Sewing Machines, Regent Street, Swindon.
Sarum Sewing Centre, 25 Catherine Street, Salisbury.

YORKSHIRE

Lennox Sewing Machines, 2 Red Lion Yard, Rotherham.
Co-op Limited, Albion Street, Leeds.
Penny Oak Mills, Falcon Oak, Bartle Lane, Bradford.
Sewing & Knitting Centre, 193 Burtonstone Lane, York.
Sewing & Knitting Centre, 168 Lower Briggate, Leeds.
Co-op Limited, Jamieson Street, Hull.
The Woolly Jumper, 653 Queens Road, Sheffield.
Lewis's Limited, The Headrow, Leeds.
Sewing Supply Co., 4 Market Road, Doncaster.
Maynells, 180 Linthorpe Road, Middlesborough.
Woolco Limited, New Town Centre, Stockton on Tees, Thornaby.

WALES

Needlecraft, 29 Pendre, Cardigan, Dyfed.
North Wales Home Knitting, Rhyll Road, Denbigh.
The Stepey Wool Shop, Market Arcade, Llanelli, Dyfed.
Margarets Wool Shop, 17 Penallta Road, Hengoed, Mid Glam.
Victoria Davies 'Siop Newydd' Llanegryn, Towyn, Gwynedd.
Paul Britten Sewing Machines, 70 Dunraven Street, Tonypany.
Wollangers, Lord Street, Wrexham.
David Evans Limited, Princess Street, Swansea.
Nantiago Homecraft, 33 Frogmore Street, Abergavenny, Gwent.

SCOTLAND

Knitting Machine Centre, 374/376 Argyle Street, Glasgow.
Banff Sewing & Knitting, 15 Boyndie Street, Banff.
J & A Machine Wools, 159 Main Street, Bonhills, Dunbartonshire.
T. Baird Ltd., Princess Street, East Kilbride.
T. Baird, 1 Duke Street, Hamilton.
Bairds Limited, 54-60 Merry Street, Motherwell.
Bairds Limited, 86-94 Main Street, Wishaw.
Arnotts Limited, 2-8 Manschal Street, Peterhead.
Arnotts Limited, Riverside, Irvine.
Arnotts Limited, 11 Gauze Street, Paisley.
Arnotts Limited, High Street, Dingwall.
Arnotts Limited, 121-123 High Street, Elgin.
Arnotts Limited, Banff.
Fairbuys, 38 Kinneddar Street, Lossiemouth, Morayshire.
Bairds, High Street, Falkirk.
Arnotts Limited, 15 North Bridge, Edinburgh.
Arnotts Limited, Argyle Street, Glasgow.
Arnotts Limited, Barnton Street, Stirling.
Arnotts Limited, Hamilton Way, Greenock.
Arnotts Limited, 7-12 Union Street, Inverness.
Arnotts Limited, Aberdeen.
Bonnybrae Knitwear Designs, Golspie, Sutherland.
Arnotts Limited, 22-30 Alloway Street, Ayr.
Northern Sewing Machines, 5 Urquhart Road, Aberdeen.
Huntley Sewing Machines, Old Post Office, Boghead, Cairnie, Aberdeen.
Arnotts Limited, 80 High Street, Dundee.
Martins Machine Centre, 8/10 Main Street, Dundee.
Machine Knitting Wool, 104 Quarry Street, Hamilton, Lanarks.
Inverness Sewing and Knitting Centre, 4 Hill Place, Inverness.
Dumfries Sewing and Knitting Machines, 1a St. Marys Street, Dumfries.

NORTHERN IRELAND

Needlecraft, 34 Longstone Street, Lisburn, Co. Antrim.