

Jones / brother

# Stitchin' time

Vol3 No3

25p





# contents

Mini jumper and shorts	3-4
Midi skirt and jacket	5-6
Hot pants	6
Mans waistcoat	7
Mans cardigan	8
Ladies skirt and cardigan	9-10
Matinee jackets	12-13
Pram coat and cover	13-14
Sew Easy! Lesson 4	15-22
Ladies saddle shoulder dress	23-24
Ladies lacy twin-set	25-26
You write	27
Ladies woven suit	28-29
Jones clubs	30-31
Aran-style knitting	32-35

## SUBSCRIPTION RATES FOR U.S.A. AND CANADIAN MEMBERS

CANADA \$8.00

U.S.A. \$7.50

(These rates include postage)

# Broadly Speaking

To keep ahead with fashionable, wearable clothes is not very difficult when you have a Jones machine to help you, and to prove the point we have included knitwear patterns in this issue to start the cooler season in fine fashion.

The ladies' patterns include a versatile lacy twin-set: midi-suit which could be worn with or without a top garment; a skirt with matching cardigan and a well-designed day-dress.

You may choose perhaps to knit only one of these, but if you decide to knit all four, you will find you have created the basis to a useful and versatile wardrobe for the Autumn.

In addition to young-trend styles and patterns for men, we have included a Baby Section in this issue. This is a new feature to *Stitchin' time* and we have selected three different matinee jackets, plus pram cover and pram coat, for you to make.

Following a number of requests for more information on Aran knitting, we are very pleased to include a helpful article on the subject written for *Stitchin' time* by our designer Mrs. Osborn. This article will be of interest to beginners as well as more advanced knitters, since it aims to show how a quickly-knitted, plain garment can be given that highly individual touch of Aran or cable trimming, without difficulty.

Turning to the Sew Easy Course, you will see this has reached the Fourth Lesson and deals with the insertion of zips, shirt sleeves and pockets. We think this lesson should prove particularly useful and will help to achieve the smooth, professional finish that can add so much to the good looks of a garment.

Entries are still coming in for the knitting and photographic competition announced in the last issue, and so we have decided to extend the closing date until December 20th. A second entry form is included in this issue, and as a reminder to readers, the first prize for the best photograph is a Knitleader attachment and there are 100 other prizes for the runners-up. For those of you who may have missed details of the competition in the last issue, information is included in this month's Jones Club Page.

Whilst on the Knitleader, those of you who already own this attachment, will be pleased to know that we have produced a new set of basic shapes for men, women and children; chest sizes 20" - 50" and these produce "v" or round-neck cardigans or sweater with raglan sleeves. These are now available from Finchley at 45p per set, inclusive of postage and packaging.

You will see from the Jones Club Page that meetings are starting throughout the country once again. The new "Jones Club Diary" gives full details of forthcoming meetings, but unfortunately at the time of going to Press, we have not received details from every Club and therefore you may wish to write into Finchley for details, should your area not be included.

We are always pleased to receive reader's comments on the magazine and the letters which followed the last issue were particularly gratifying since we learned from many of you that we are now including the sort of articles and patterns you really wish to see.

We think this issue continues the trend, and hope it will take you into Autumn in colourful fashion.



# mini jumper and shorts



Mini jumper with scoop neckline and short sleeves, worn with shorts. Hem of jumper, sleeves and pockets banded in three colour pattern.

## Materials

**Jumper:** 5 (5, 6) ozs. main colour.

1 (1, 1) oz. each of contrast colours in Patons Bouclet.

**Shorts:** 5 (6, 6) ozs. main colour.

1 (1, 1) oz. each of contrast colour. in Patons Bouclet.

1 8-inch zip. 1 yard of 1 inch wide skirt elastic. No. 11 crochet hook.

## Measurements

To fit 32 (34, 36) inch bust.

34 (36, 38) inch hip.

13 (14, 15) inches Jumper back length.

5½ (6, 7) inches sleeve seam.

## Tension

13 sts. and 21 rows to 2 inches over T6

## Abbreviations

T., tension; N., needle; st(s), stitch(es); K., knit; pos., position; 000., set row counter to 000; C.O.R., carriage on right; C.O.L., carriage on left; foll., follow(ing); Inc., increase; Dec., decrease; beg., beginning; rem., remaining; Rep., repeat; H.C.L., holding cam lever; alt., alternate; fin., finish(ing); patt., pattern; tog., together; cont., continue.

## Note

Instructions for larger sizes in brackets ( ), where only 1 figure is given this applies to all sizes.

## JUMPER

### Back

\* T4. Cast on by hand over every N. 86 (92, 98) sts. K. 10 rows. T8. K. 1 row for foldline. T4. K. 10 rows. Make hem by placing each cast on st. on to N. in B pos. T6. K. 1 row. T6. 000. C.O.R. Work rows 1 to 22 from patt. diagram once at the same time inc. 1st. at each end of every foll. 5th row (94, 100, 106) sts. 000. Inc. 1 st. at each end of foll. 3rd row and every foll. 5th row to 104 (110, 116) sts. K. to row 26 (32, 38).

### Shape Armholes

Cast off 5 (6, 7) sts. at the beg. of the next 2 rows. 94 (98, 102) sts. \* 000. Dec. 1 st. at each end of every other row to 76 (80, 84) sts. (18 rows). 000. K. 50 (55, 59) rows.

### Shape Shoulders

Cast off 4 sts. at the beg. of the next 8 rows. Cast off 3 (4, 5) sts. at the beg. of the next 2 rows. Cast off rem. 38 (40, 42) sts.

### Front

Rep. from \* to \* as for Back. 000. C.O.R. Cast off 20 (22, 24) sts. at centre of work. Work on right 37 (38, 39) sts. only. Push left N. to E pos. H.C.L.s on II. 000. Dec. 1 st. at each end of every other row to 19 (20, 21) sts. (18 rows). 000. K. 50 (55, 60) rows.

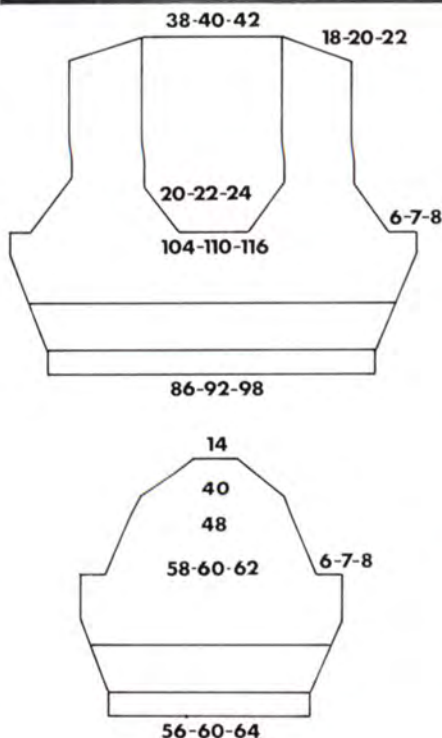

### Shape Shoulder

C.O.R. Cast off 4 sts. at beg. of the next row and at this same edge every alt. row 3 times more fin. with C.O.R. Cast off rem. 3 (4, 5) sts. H.C.L.s to I. Work rem. left sts. to match right reversing shapings.

### Sleeves

T4. Cast on by hand over every N. 56 (60, 64) sts. K. 10 rows. T8. K. 1 row for foldline. T4. K. 10 rows. Make hem by placing each cast on st. on to N. in B pos. T6. K. 1 row. T6. 000. C.O.R. Work rows 1 to 22 from patt. diagram once at the same time inc. 1 st. at each end of every 5th row 64 (68, 72) sts. 000. Inc. 1 st. at each end of foll. 3rd row and the foll. 5th row to 68 (72, 76) sts. K. to row 25 (30, 35).

### Shape Top

Cast off 5 (6, 7) sts. at the beg. of the next 2 rows. 58 (60, 62) sts. 000. Dec. 1 st. at each end of every 4th row to 20 (24, 28) rows. (48 sts.). 000. Dec. 1 st. at each end of every foll. 3rd row to 40 sts. (12 rows). 000. Dec. 1 st. at each end of every row to 14 sts. (13 rows). Cast off.

### Neckband

T4. Cast on by hand over every N. 124 (130, 136) sts. K. 10 rows. T8. K. 1 row for foldline. T4. K. 10 rows. Make hem by placing each cast on st. on to N. in B pos.







# midi skirt and jacket

## Materials

Jacket: 20 (20, 21, 21) ozs. Patons four seasons; 6 buttons; 6 press-studs; 2 yds. 1-inch wide facing ribbon.

Skirt: 15 (16, 16, 17) ozs.; 1-inch wide elastic to fit waist.

## Measurements

Jacket: to fit a 34 (36, 38, 40) inch bust; actual measurements 37 (39, 41, 43) ins.; length to top of shoulder 25 (25½, 25½, 25¾) ins.; sleeve seam 17 ins. (all sizes).

Skirt: to fit 36 (38, 40, 42) inch hips; length 27 ins. (all sizes).

## Tension

12 sts. and 20 rows to 2 ins. over st.st.  
18 rows to 2 ins. over lace pattern.

## Abbreviations

K., knit; st., stitch; rep., repeat; alt., alternate; tog., together; inc., increase; dec; decrease; beg., beginning; H.P., holding position; H.C.L's, holding cam levers; T., tension; 000, set row counter at 000.

## Note

Owing to the uneven quality of the yarn make sure that the sts. have knitted on the first row after making the holes. Leave comb on work and pull down every 10 rows or so.

## Jacket—Back

Cast on 112 (118, 124, 130) sts. by hand. \* T8. Knit 10 rows. 000. T9. Knit 10 rows. Work 20 rows of lace pattern from chart. T9. Knit straight until 170 rows have been worked. \* (Adjust length here if required).

## Shape Armholes

000. Cast off 4 sts. at beg. of next 2 rows. Dec. 1 st. at both ends of next 3 rows and then every following alt. rows until 88 (94, 98, 104) sts. remain Knit straight until 70 (72, 76, 78) rows have been worked.

## Shape Shoulders

Cast off 6 sts. at beg. of next 8 rows and 3 (5, 6, 8) sts. at beg. of next 2 rows. Cast off remaining 34 (36, 38, 40) sts. using chain method.

## Right Front

Cast on 60 (63, 66, 69) sts. by hand. Knit as given for Back from \* to \*.



## Shape Armhole and Neck

000. Cast off 4 sts. at beg. of next row. Dec. 1 st. at neck edge on next and every following 3rd row by transferring 2nd st. on to 3rd needle and moving end st. 1 needle in. Push empty needle to A position at the same time dec. 1 st. at armhole edge on next 3 rows and then every alt. row 5 (5, 6, 6) times. Keeping armhole edge straight, continue neck shaping until 27 (29, 30, 32) sts. remain. Knit straight until 70 (72, 76, 78) rows have been worked.

## Shape Shoulder

Cast off 6 sts. at beg. of next and every alt. row until 3 (5, 6, 8) sts. remain. Knit 1 row. Cast off.

## Left Front

Knit as Right Front, reversing all shapings by casting on at opposite end of

machine.

## Sleeves

The Pattern. Knit 20 rows of pattern. Knit 30 rows in st.st. 50 rows in all. Cast on 48 (52, 56, 60) sts. by hand. T8. Knit 10 rows. 000. T9. Knit 10 rows. Following pattern, at the same time inc. 1 st. at each end of next and every following 9th row until there are 80 (84, 88, 92) sts. Knit straight until 162 rows have been worked. (This gives a sleeve length of 17 ins. Adjust length here if required).

## Shape Top

Cast off 4 sts. at beg. of next 2 rows. Dec. 1 st. at each end of next 3 rows and then every following alt. row until 34 (38, 40, 44) sts. remain. Dec. 1 st. at both ends of every row until 18 (18, 20, 20) sts. remain. Cast off.



# hot pants

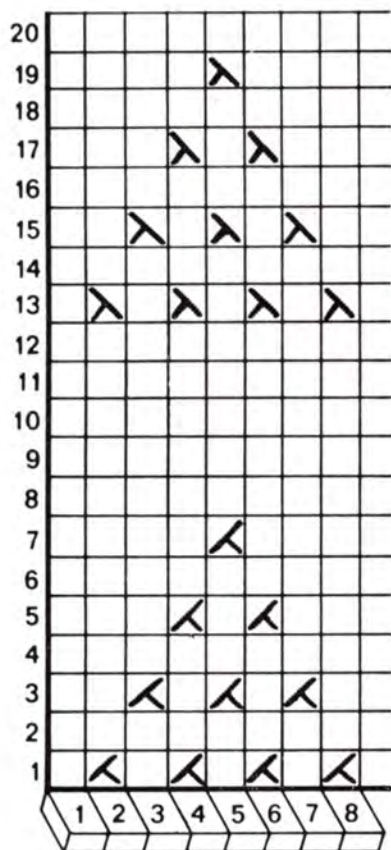

## To Finish

Pin out to size and press with a hot iron over a very wet cloth. Join side shoulder and sleeve seams. Turn hems at lower edge and cuffs to wrong side and slip-st down. Sew facing ribbon in position, up fronts and across back neck making small pleats at vee of neck and shoulder seams. Sew press-studs in position, then buttons on top of press studs. Sew in sleeve tops. Press seams.

## Skirt — Back and Front Alike

Cast on 152 (158, 164, 170) sts. by hand. T8. Knit 10 rows. 000. T9. Knit 10 rows. Following 20 rows of pattern, dec. 1 st. at each end of next and every following 9th row 3 times in all. Knit 2 rows. (30 rows). H.C.L. III. Always winding wool round first needle in H.P. push 12 (13, 14, 15) needles at opposite end to carriage to H.P. on next 8 rows. Return needles to W.P. on next 2 rows. Knit 7 rows. Dec. 1 st. at each end of next and every following 9th row until there are 110 (116, 122, 128) sts. 201 rows. Mark ends with coloured wool. Knit 6 rows. Dec. 1 st. at each end of next and every following 6th row 7 times in all and then every following 4th row until 88 (94, 100, 106) sts. remain. Knit 1 row.

## For Ribbers

Transfer sts. for 1 + 1 rib. T6. Knit 10 rows. Cast off loosely with knitting needles.

## Single Bed Machines

T8. Knit 12 rows. Cast off loosely with knitting needles.

## To Finish

Pin out to size and press with a hot iron over a very wet cloth. Join side seams. Turn hem to wrong side and slip st. down. Cut elastic to fit waist. Join ends and place elastic inside waist band and work a herringbone st. over elastic to form a casing. Press seams.

## Materials

7 oz. 4 ply wool.  
(If required small amount of wool for applique or material to sew on).  
5 in. zip.  
Lining for bib, if required.

## Measurements

To fit hips 32 (33, 34, 35) ins.

## Tension

8 st. and 10 rows to 1 in.

## LEFT LEG

T.5 cast on 149 (153, 157, 161) sts. K.9 rows. T.10. K.1. R. T.5 K. 9 rows. Make hem. T.7 incr. each end on next and foll 6th row three times in all 155 (159, 163, 167) sts. Knit 1 row. C.O.R.

## Shape crotch

Cast off 3 sts. at beg. of next row, K. to end. Cast off 6 st. at beg. of next row, K. to end. 146 (150, 154, 158). Dec. 1 st. each end of next 10 rows. 126 (130, 134, 138) sts. Dec. 1 st. each end of every foll. 5th row. 118 (122, 126, 130). K. 6 rows. C.O.R.

## Shape front hip

Push left 59 (61, 63, 65) sts. to E. pos. H.C.L's to III. 000. Continue on right side sts., decr. 1 st. every foll. 4th row on hip edge to 52 (54, 56, 58) sts. 000. Dec. 1 st. every foll. 3rd row on hip edge. 46 (48, 50, 52) sts. C.O.L.

## Shape front waist

Cont. dec. every 3rd row from last decr. on hip as before. 4 times more, and at same time shaping as follows: K. 2 rows. Push 22 (24, 26, 28) sts. to E pos. K.2 rows. Push 4 sts. to E pos. on next and each alt. row three times more until 5 sts. are left in B pos. C.O.L. right H.C.L. to II. Push the 38 (40, 42, 44) sts. in E pos. to D pos. K. 2 rows. C.O.L. Transfer 22 (24, 26, 28) sts. from Right side to stitchholder (for bib front). K.10 rows on rem. 21 sts. Cast off.

## Shape back hip

H.C.L's to I. 000. Continue on left 59 (61, 63, 65) sts. decr. 1 st. every foll. 4th row on hip edge to 52 (54, 56, 58) sts. Decr. 1 st. every foll. 3rd row on hip edge to 42 (44, 46, 48) sts. K. 10 rows. Cast off.

## Right leg

Work same as left leg reversing shaping.

## Bib front

Pick up 22 (24, 26, 28) sts from each front hip 44 (48, 52, 56) sts. Cast on 10 sts. beg. next 2 rows 64 (68, 72, 76) sts. K. 65 rows. Cast off 10 sts. beg. next 2 rows. Cont. K. on middle sts. for further 10 rows. Cast off.

## Straps (2)

Cast on 24 sts. K. 260 rows. Cast off. Cast on 24 sts. K. 70 rows or, according to width across back.

## To complete

Pin out and press with a hot iron over a damp cloth. Sew seam over hips. Sew front and back seams, allowing for zip, to be inserted at back. Turn over waistband and neaten at zip top. Turn extra knitted sts. on side of bib and make hem at back of bib. Sew straps and turn inside out, Sew long straps to back of bib and waistband at back. Sew short strap across at back.

If making appliqué as pattern, sew dots on first after marking appliqué for position. Pin appliqué where required, and stem st. over top with black wool, to make cube outline. Stitch appliqué round edge if required bib can be lined.







# mans cardigan

## Materials

20 (22, 24, 26, 28, 30) ozs. Listers Lavenda Double Knitting. 1 oz. Listers Lockinvar for contrast. 5 buttons.

## Measurements

To fit chest sizes 38 (40, 42, 44, 46, 48) ins.  
Finished measurements 40 (42, 44, 46, 48, 50) ins.  
Length at back neck 25 (25½, 26, 26½, 27, 27½) ins.  
Sleeve seam: 17½ ins.

## Tension

12 sts. and 17 rows to 2 inches.

## Abbreviations

Ins., inches; sts., stitches; inc., increase; dec., decrease; alt., alternate; foll., following; beg., beginning; T., tension; 000, return row counter to 000.

## Notes

Fully fashioning at raglan edges is worked by transferring the 4th st. on to 5th needle and moving the 3 end sts. 1 needle in. Fully fashioning at V-neck is worked by transferring the 2nd st. on to 3rd needle and moving the end st. 1 needle in.

## Back - Ribbers

Cast on 121 (127, 133, 139, 145, 151) sts. for 1x1 rib. T6/6. Knit 12 rows. Transfer sts. to main bed for stocking-stitch.

## Single machines

Cast on 61 (64, 67, 70, 73, 76) sts. on alt. needles. T9. Knit 23 rows. Make a hem and knit the row. 121 (127, 133, 139, 145, 151) sts.

## All machines

000. T10. Knit straight for 116 rows. This will give a length of 15 ins. from base of garment. Adjust length here if required.

## Shape Raglan Armholes

000. Cast off 3 sts. at beg. of next 2 rows. Knit 2 rows. Dec. 1 st. (see notes) at each end of next and foll. 4th row, then every foll. alt. row until 35 (37, 39, 41, 43, 45) sts. remain. Knit 1 row. Cast off.

## RIGHT FRONT - Ribbers

Cast on 55 (57, 61, 63, 67, 69) sts. for 1x1 rib. T6/6. Knit 12 rows. Transfer sts. to main bed for stocking-stitch.

## Single machines

Cast on 28 (29, 31, 32, 34, 35) sts. on alt. needles. T9. Knit 23 rows. Make a hem and knit the row. 55 (57, 61, 63, 67, 69) sts.

## All machines

Inc. 1 st. at right side on sizes 2, 4 and 6. 000. T10. Knit straight for 100 rows.

## Shape Neck

Dec. 1 st. at left side (see notes) on next and every foll. 10th (10th, 8th, 8th, 8th, 8th) row at the same time knit a further 16 rows. (116) rows.

## Shape Armhole

000. Continuing neck shaping, cast off 3 sts. at beg. of next row. Knit 3 rows. Dec. 1 st. at raglan edge on next and foll. 4th



row, then every foll. alt. row until 7 (4, 12, 10, 8, 6) sts. remain. Keeping neck edge straight, continue raglan shaping until 2 sts. remain. Cast off.

## LEFT FRONT

Knit as Right Front reversing all shapings.

## SLEEVES - Ribbers

Cast on 61 (65, 67, 71, 73, 77) sts. for 1x1 rib. T6/6. Knit 20 rows. Transfer sts. to main bed for stocking-stitch.

## Single machines

Cast on 31 (33, 34, 36, 37, 39) sts. on alt. needles. T9. Knit 39 rows. Make a hem and knit the row. 61 (65, 67, 71, 73, 77) sts.

## All machines

000. T10. Knit 8 rows. Inc. 1 st. at each end of next and every foll. 7th row until there are 91 (95, 97, 101, 103, 107) sts. Knit straight until 126 rows have been worked. This will give a finished sleeve seam of 17½ ins. Adjust here if required.

## Shape raglan top

Cast off 3 sts. at beg. of next 2 rows. Knit 2 rows. Dec. 1 st. at each end of next and every foll. 4th row 5 (5, 6, 6, 7, 7) times in all, then every following alt. row until 11 sts. remain. Knit 1 row. Cast off.

## FRONT BAND

Mark Left Front for 5 buttonholes, the first ¼ inch above lower edge the final one at beginning of neck shaping. Space pockets remainder evenly between.

## Ribbers

Cast on 17 sts. as 1x1 rib. T6/6. Knit straight making buttonholes to match markers over needles 7 to 11. Knit until long enough to fit along both fronts, across sleeve tops and across back neck stretching to fit. Cast off.

## Single machines

Cast on 26 sts. by hand. T9. Knit straight, making buttonholes to match markers over needles 6-8 from each end. Knit until long enough to fit along both fronts, across sleeve top and across back neck, stretching to fit. Cast off.

## FAIR ISLE POCKETS - Ribbers

Cast on 37 sts. as 1x1 rib. T6/6. Knit 6 rows. Transfer sts. to main bed for Fair Isle.

## Single machines

Cast on 19 sts. on alt. needles. T9. Knit 7 rows. Make a hem and knit the row. 37 sts.

## All machines

T10. Knit 2 rows. Follow chart (or design of own choice) for 40 rows. Cast off using chain method.

## To Make Up

Pin out and press with a cool iron over a dry cloth. Join side, sleeve and raglan seams. Sew ribbed front band in position, neaten buttonholes and sew on buttons. Sew stocking-stitch front band in position, turn to wrong side and slip st. in place. Neaten buttonholes and sew on buttons. Sew pockets in position as required. Press seams.



# ladies skirt with round or Vneck cardigan

## Materials

Patons and Baldwins Purple Heather 4-ply.  
**Round or Vee-Neck Cardigan** 16 (16, 17, 17, 17, 18, 18) ozs. 6 buttons for Round-neck Cardigan and 5 buttons for Vee-neck Cardigan.

**Skirt:** 11 (11, 12, 12, 13, 13, 14) ozs.  $\frac{3}{4}$ -inch wide elastic for waist.

## Measurements

Cardigan: to fit bust sizes: 34 (36, 38, 40, 42, 44, 46) ins;

Finished measurements: 36 (38, 40, 42, 44, 46, 48) ins.

Length to back neck: 23 (23 $\frac{1}{2}$ , 23 $\frac{1}{2}$ , 23 $\frac{3}{4}$ , 24, 24 $\frac{1}{2}$ , 24 $\frac{1}{2}$ ) ins.

Sleeve seam: 17 $\frac{1}{2}$  ins. all sizes.

**Skirt:** To fit hip sizes: 36 (38, 40, 42, 44, 46, 48) ins.

Finished measurements: 38 (40, 42, 44, 46, 48, 50) ins.

Length to tip of waistband: 21 (21, 21 $\frac{1}{2}$ , 21 $\frac{1}{2}$ , 22, 22, 22) ins.

## Tension

Pattern: 12 sts. and 30 rows to 2 ins.

**Stocking-stitch:** 14 sts. and 20 rows to 2 ins.

## Abbreviations

Sts., stitches; inc., increase; dec., decrease; rep., repeat; foll., following; alt., alternate; beg., beginning; H.C.L's, holding cam levers; T., tension; 000., set row counter to 000.

## Notes

Figures in brackets ( ) refer to the larger sizes respectively.

**Shaping Darts:** On 3rd row of pattern push H.C.L. nearest to Carriage to II instead of I as given on chart. Push needles not held by shaping back to C position by hand. These needles will then knit to B position as normal.

## ROUND NECK CARDIGAN

### Back

Cast on 109 (115, 121, 127, 133, 139,



145) sts. by hand. T6. Knit 20 rows. 000. T7. Following pattern chart knit 196 rows. This will give a finished length of 14 ins. to raglan. Adjust length here.

### Shape Raglan Armholes

000. Cast off 4 (4, 5, 5, 6, 6, 7) sts. at beg. of next 2 rows. Knit 2 rows. Dec. 1 st. at each end of next and every foll. 4th row until 39 (45, 47, 53, 55, 61, 63) sts. remain, then every foll. alt. row until 33 (35, 37, 39, 41, 43, 45) sts. remain. Knit 1 row. Slip sts. on to a knitting needle. Cast off sts. for Vee-neck Cardigan.

### Left Front

Cast on 51 (54, 57, 60, 63, 66, 69) sts. by

hand. T6. Knit 20 rows. 000. T7. Following pattern chart knit 179 rows. Adjust length here if required. Knit 1 row extra for Right Front.

### Shape Darts

H.C.L's III. Always winding wool round first inside needle in E position, push 4 sts. (see notes) at opposite end to Carriage to E position on next and alt. rows 7 times in all. Knit 1 row. Return needles to B position by hand. Continue in pattern for 17 rows. \*

### Shape Raglan Armhole

Cast off 4 (4, 5, 5, 6, 6, 7) sts. at beg. of next row. Knit 3 rows. Dec. 1 st. at beg. of next and every foll. 4th row. until 23 (25,







# What is it?

BEFORE YOU READ ANY FURTHER LOOK AT THE PICTURE BELOW AND GUESS WHAT IT IS!

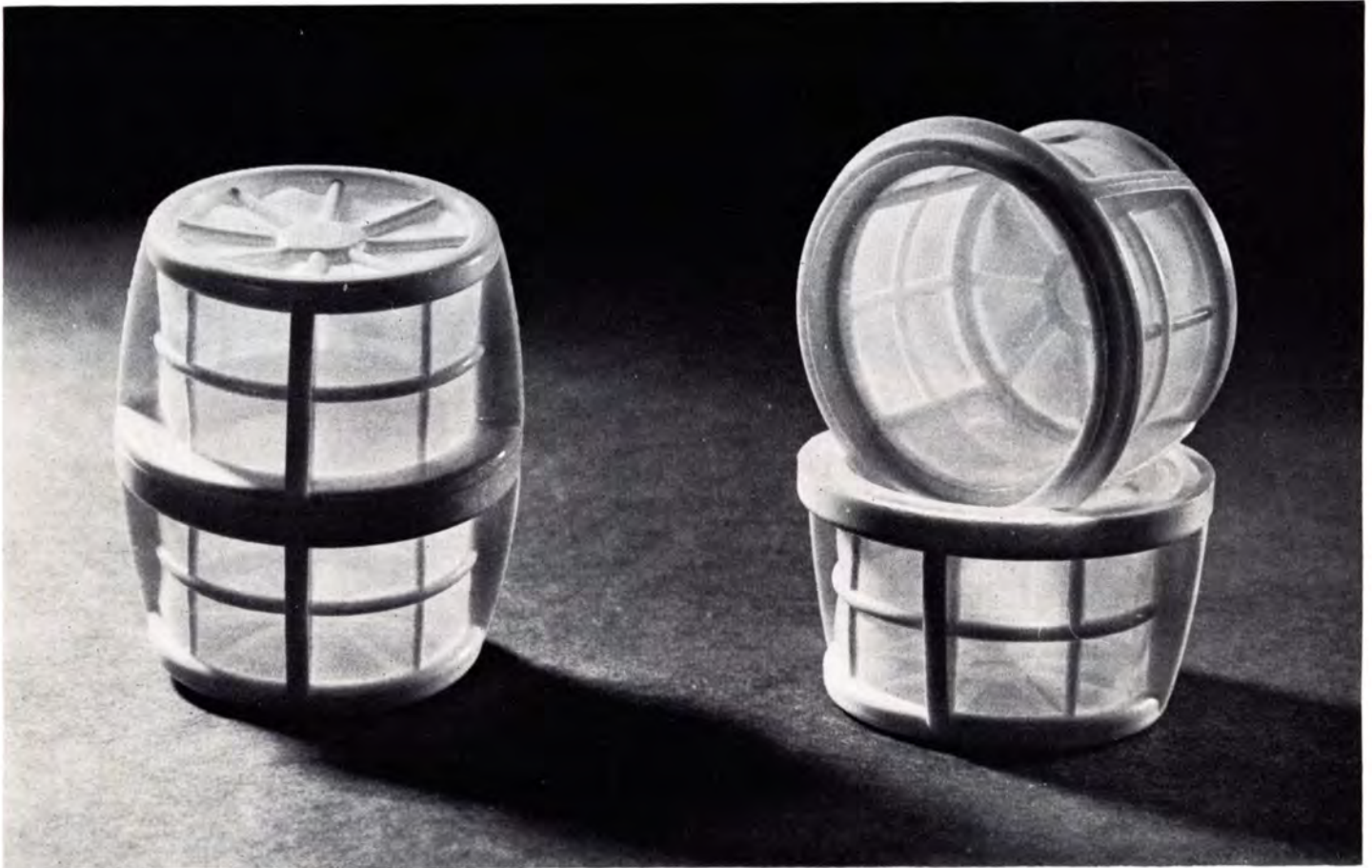

It's a Toby Teaboy!..... Let me explain – it's a refillable Tea/Coffee bag that is boilproof, tastefree and can be used over and over again – completely solving the problem of messy tea-leaves/coffee grounds.

Toby pays for himself in five weeks and saves ten times his price in a year if you buy  $\frac{1}{2}$ lb of loose tea a week instead of  $\frac{1}{2}$ lb of teabags, that's over 30p a month . . . worth saving isn't it?

With Toby you can also make a super ground coffee drink in a fraction of the time it takes to percolate and it's only 39p.

Obtainable from leading shops and stores or direct from Toby Holloware Ltd., Ausbourne Grange, Wetherby, LS22 4JD, Yorks. (Post Free).

## SPECIAL FOR JONES CLUB MEMBERS

Order a Toby Teaboy, complete a sentence and you could win an additional Teaboy plus your money back.

Please send me .....Toby Teaboy's at 39p each.

I enclose my Cheque/P.O. for.....

Complete the following sentence using not more than nine words.

*I like the idea of using Toby Teaboy because .....*

Writers of the best ten answers will each receive their money back together with a free Toby Teaboy. Names of winners will be printed in the next edition of *Stitchin' time*.

Send your answers with your order to Toby Holloware Ltd., Ausbourne Grange, Wetherby, LS22 4JD, Yorks.

















# FLAP POCKETS

# Jones SEW EASY Course Lesson 4

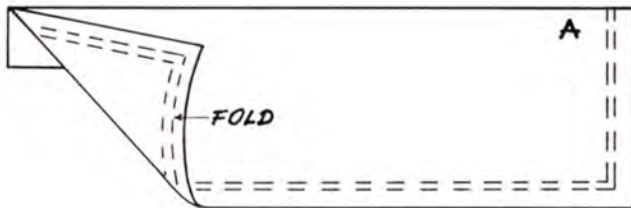

A. Basic flap pocket decorated with a double run of straight machining in the same or contrasting colour. This pocket can be cut with a folded lower edge when it is made in fine and medium weight fabrics.

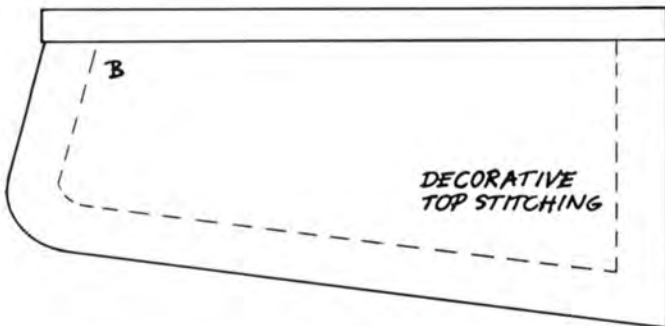

B. Asymmetrical pocket. With shaped pockets and those cut in heavier fabrics, it may be preferable to cut the underside of the flap in lining or Silesia.

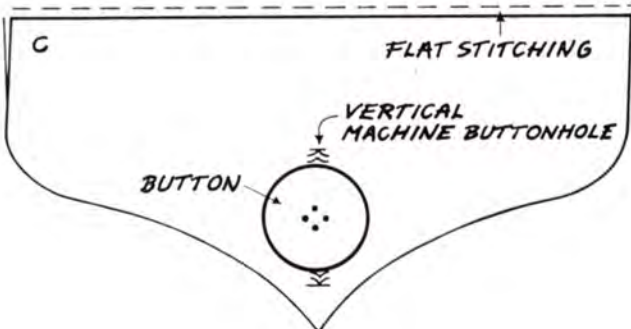

C. Symmetrical shaped flaps. Decorative button fastening. 1. Mark the position of the pocket on the garment. Prepare the pocket pieces.

INTERFACING ON THE UNDERSIDE OF FLAP.  
TRIM TO THE OUTSIDE OF THE MACHINE LINE

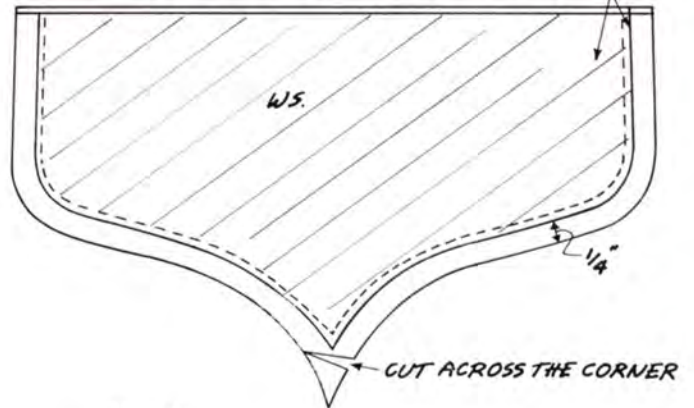

Stage 2.  
Place right sides of pocket flap and underside together, machine 1/4" from edge, trim the interfacing to the outside of the machine line.

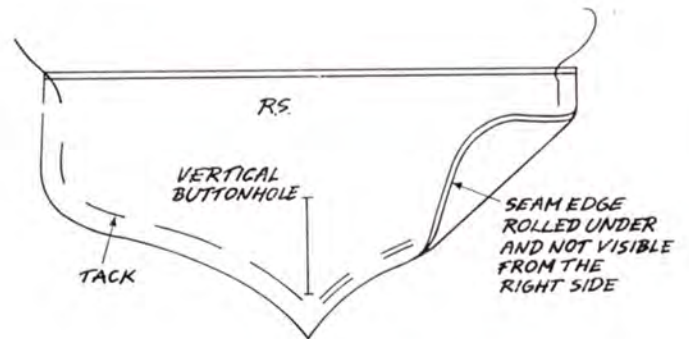

Turn the flap through to the right side. Tack round the pocket flap using the thumb and first finger of the left hand to roll the seam edge slightly under.

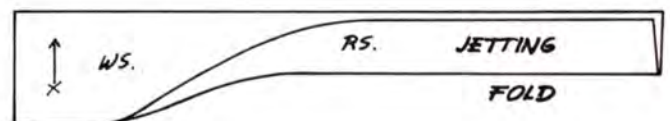

Stage 3.  
Cut a piece of fabric 1" wide the length of the pocket flap plus 1". Fold in half, press. This will form the lower jetting for the pocket.



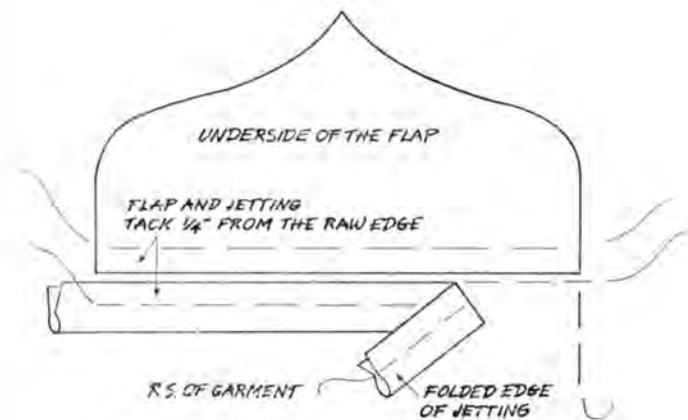

Tack the pocket flap and lower jetting on to the garment.

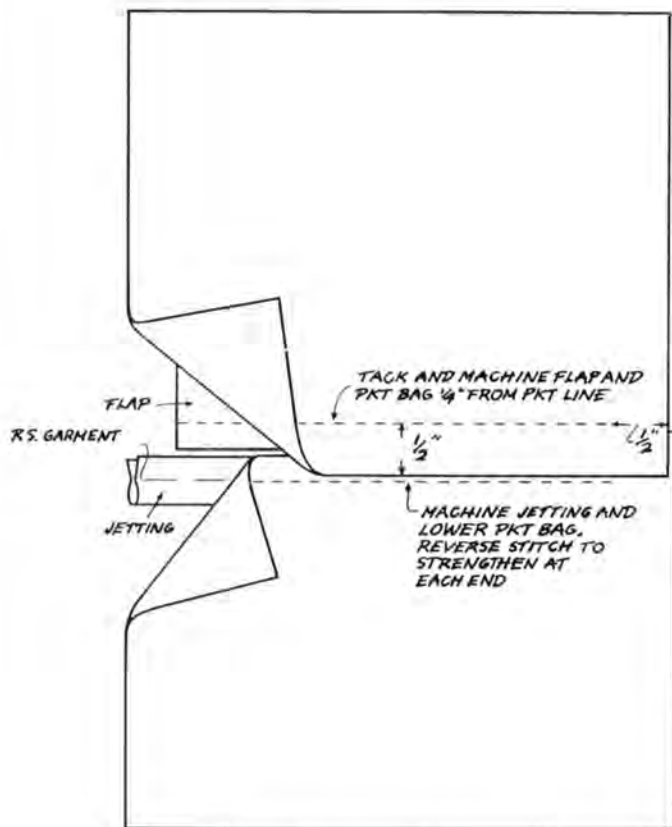

Stage 4.  
Tack the pocket bag pieces  $\frac{1}{4}$ " either side of the pocket line. Overlap the top pocket bag. Tack and machine on previous tack lines.

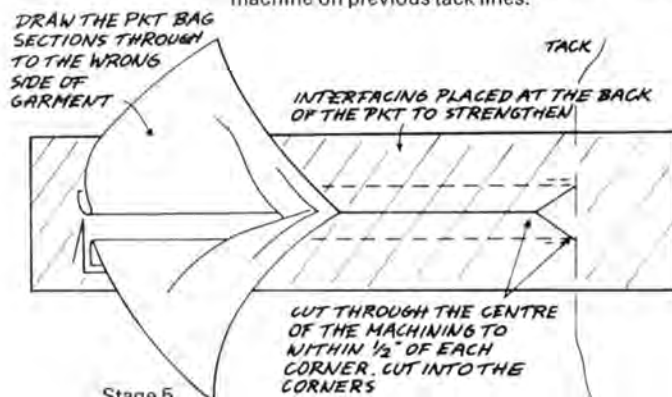

Stage 5.  
Turn to the reverse side. Cut through the centre and into each corner.

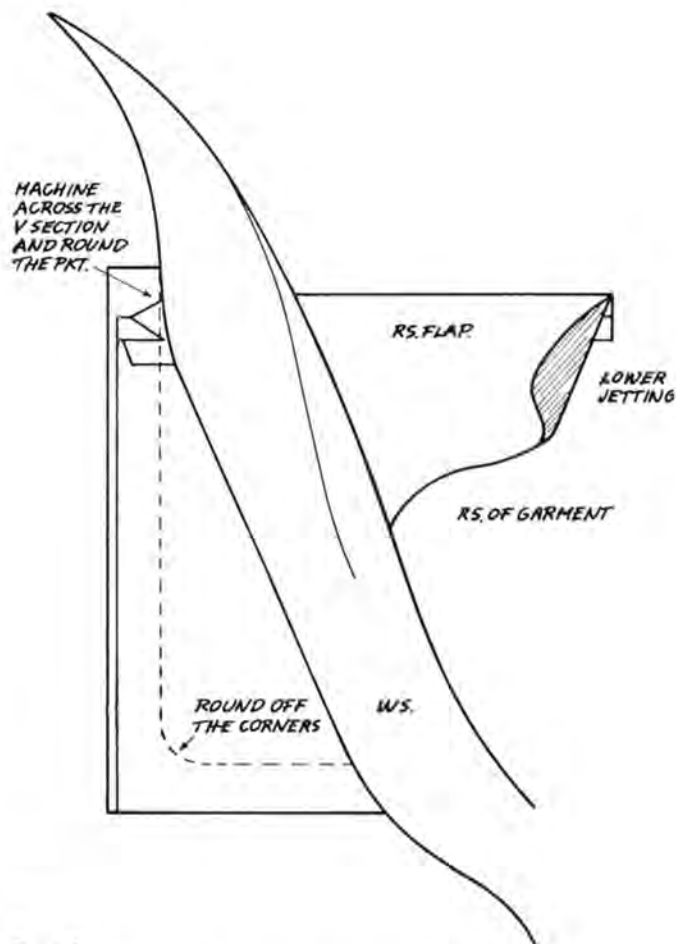

Stage 6.  
Turn to the reverse side. Press the jetting upwards. Press the flap downwards. Fold back the garment and machine round the pocket bag.

NEATEN THE INSIDE OF THE GARMENT. ZIG ZAG ROUND THE PKT. BAG. TRIM AWAY THE SURPLUS FABRIC

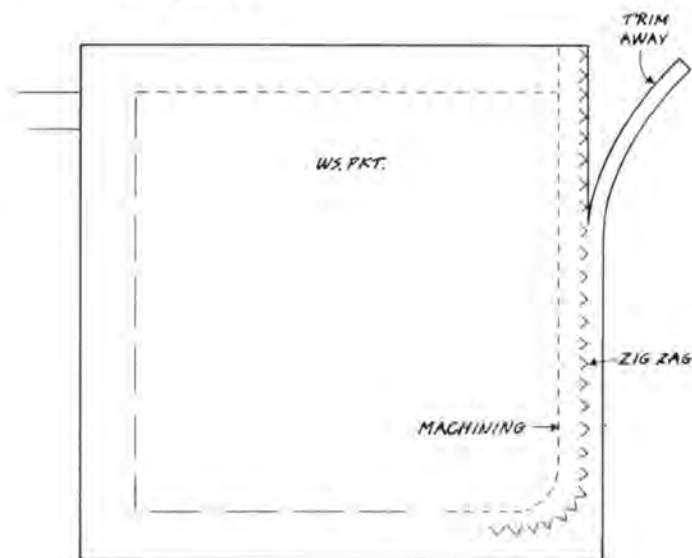

Stage 7.  
Neaten the inside of the garment. Zip zag round the pocket. Trim away the surplus fabrics.





# PATCH POCKETS

## POCKET CUT WITH A DECORATIVE TOP FACING

This part of the pocket has to be prepared first before the pocket is attached to the garment. All decorative embroidery has to be completed at this stage. Place the facing right side down on to the wrong side of the garment. Machine the top and sides of the facing edge. Trim, mitre and cut as indicated. Turn through to the right side. Press under the lower edge of the facing and machine.

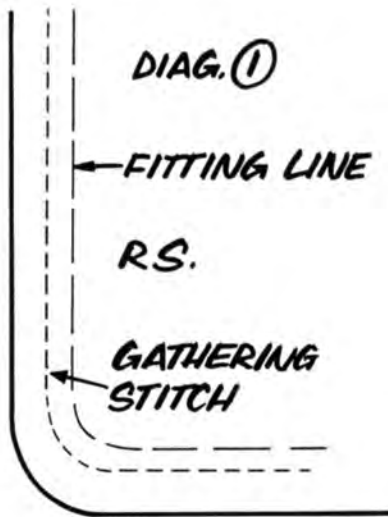
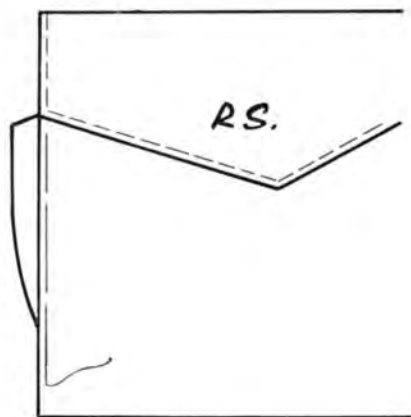
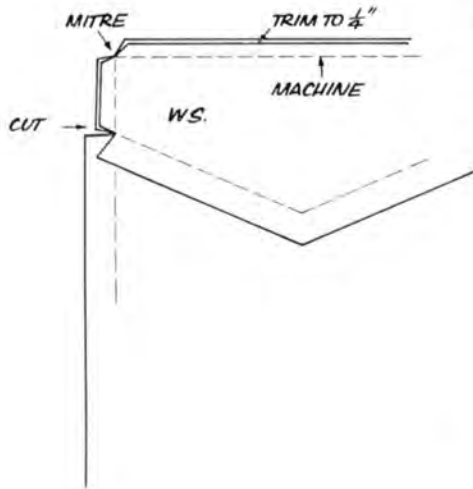

## PATCH POCKET WITH ROUNDED CORNERS

The rounded corners can be difficult to turn under smoothly. To make this simpler we suggest that you machine (large stitch) round the pocket  $\frac{1}{8}$ " outside the fitting line.

- Diag 1 Draw this thread slightly, as though you were gathering and fold under the seam allowance.
- Diag 2 For thick fabrics cut out of the corners wedge shapes of fabric.
- Diag 3 Turn and press under to give a smooth edge and flat finish.
- Diag 4 Place on to the garment and machine.

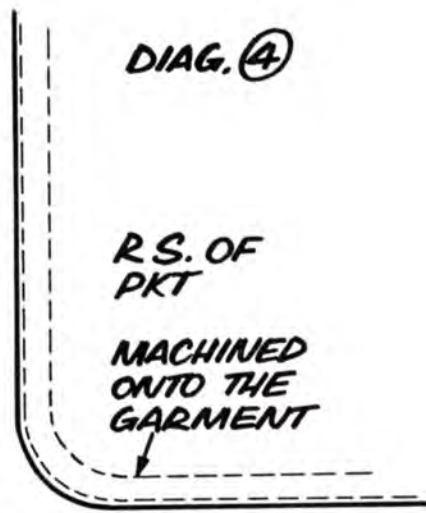
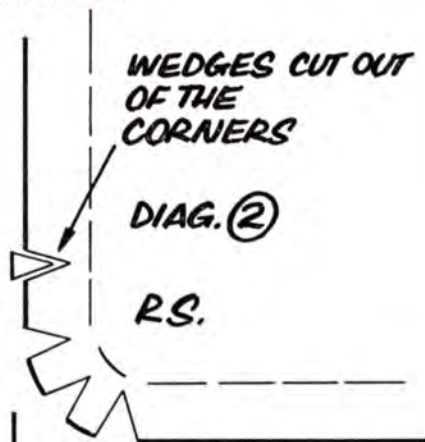

## PATCH POCKET WITH A POINTED BASE

Fold across the corners at the point where the two fitting lines meet. Trim away the corner to within  $\frac{1}{8}$ " of this point. Fold over each side. Press into position. Machine.

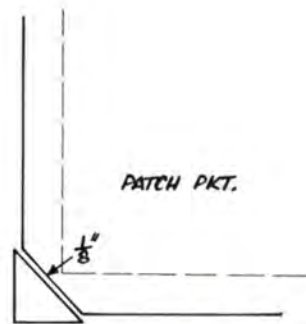
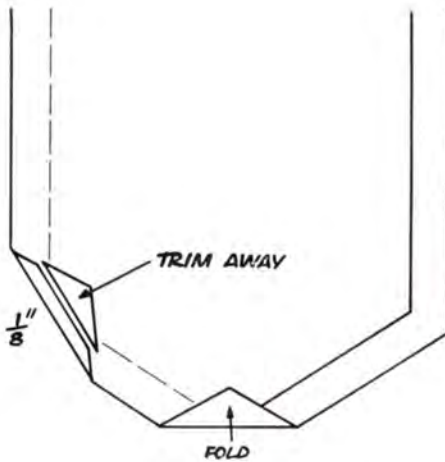



## PATCH WITH EXTENDED FACING

Fold over the facing and press. Neaten the lower edge of the facing with a wide zig zag. Turn under the sides folding over the top corner a second time. With thick fabrics trim away some of this bulk. Press. Position on the garment and machine.

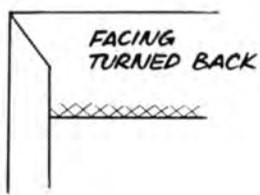
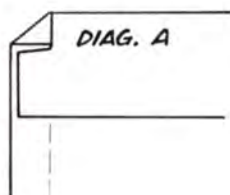
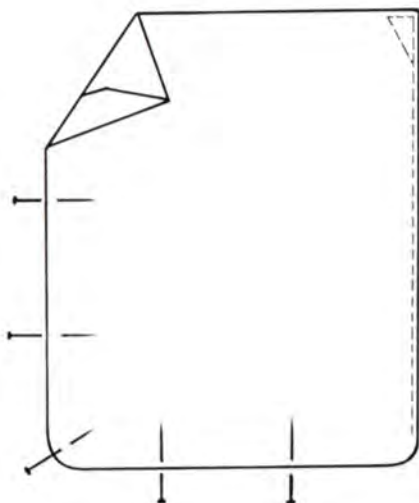
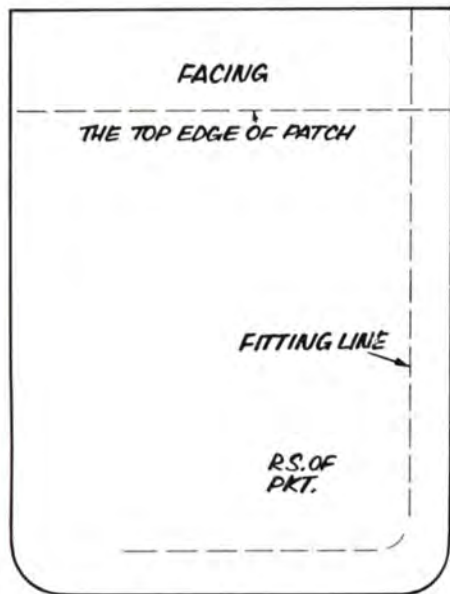

## STRENGTHENING POCKETS

Three illustrations of various ways of strengthening the top of the pocket.

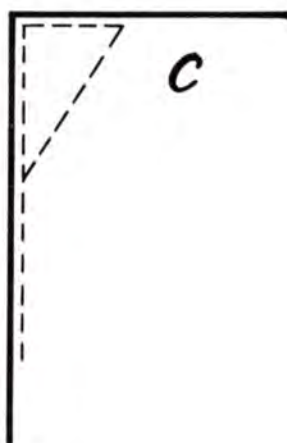
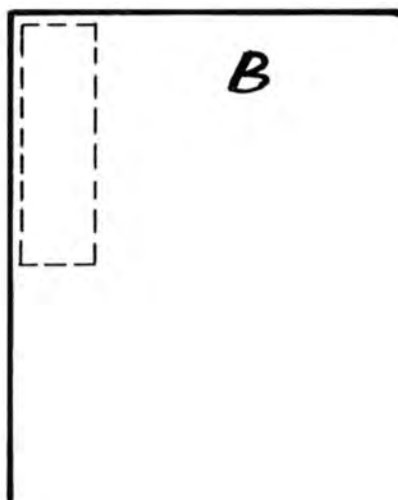
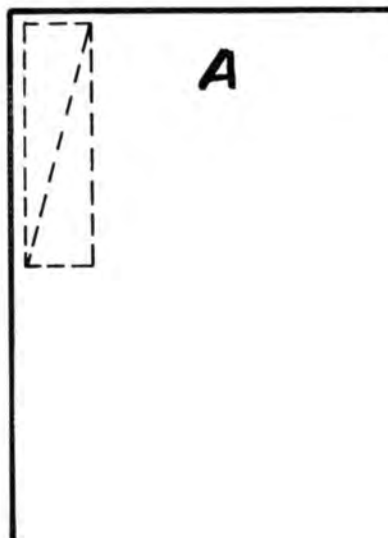

## POCKET AS PART OF GARMENT

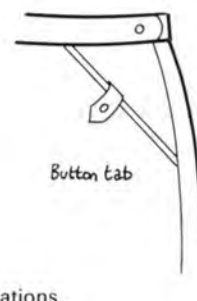
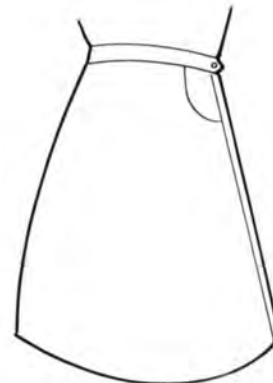

Illustrations of three variations.

PKT. CUT OUT IN ONE WITH THE GARMENT

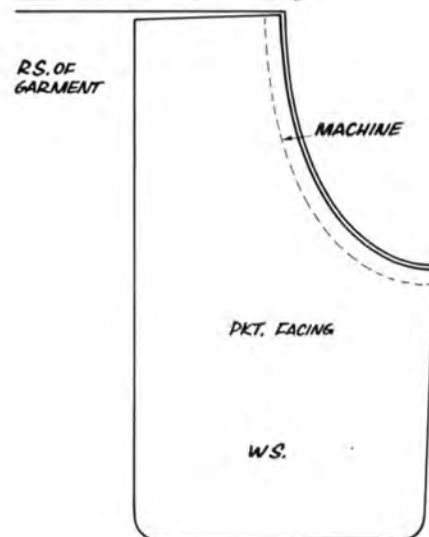

Machine the pocket facing to the garment, right sides together. Interface the pocket section to a depth of 1 - 1 1/2 inches to hold two seams in shape and prevent stretch.





# CUFF OPENING SHIRT SLEEVE

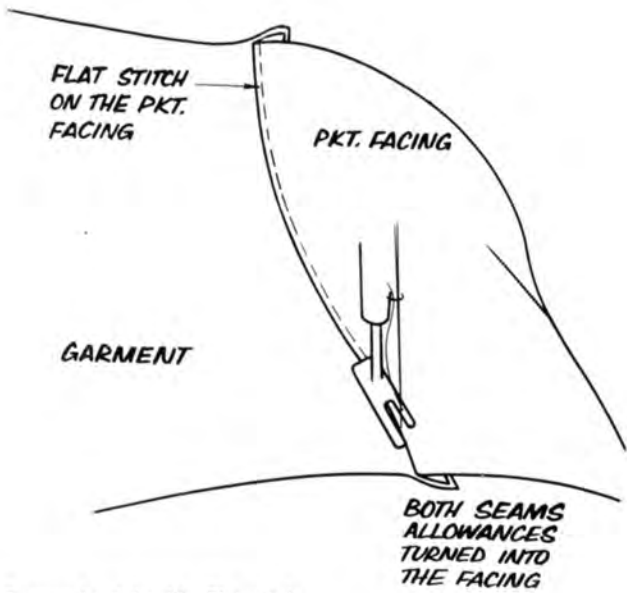

Turn to the right side. Flat stitch and press.

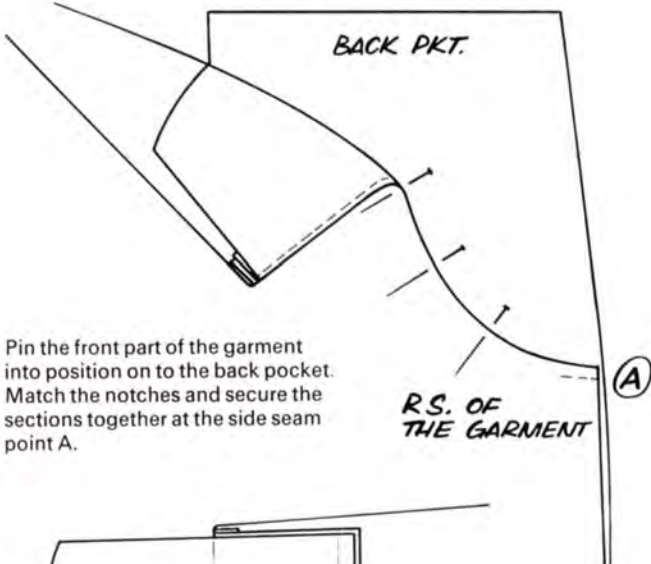

Pin the front part of the garment into position on to the back pocket. Match the notches and secure the sections together at the side seam point A.

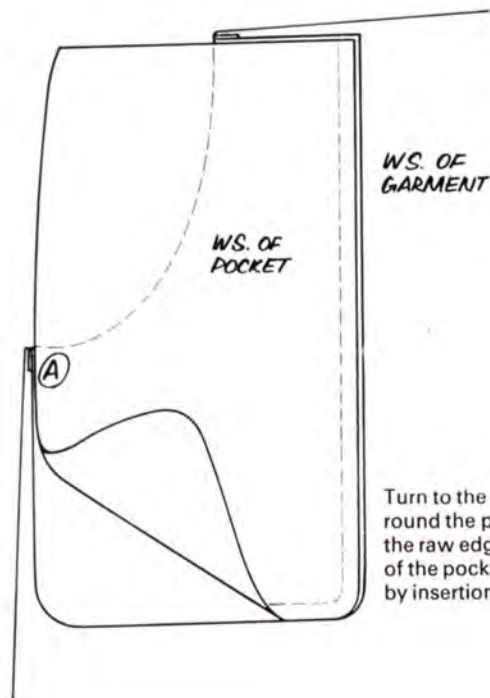

Turn to the wrong side. Machine round the pocket bag. Overlock the raw edges of the pocket. The top of the pocket will be held in position by insertion into the waistband.

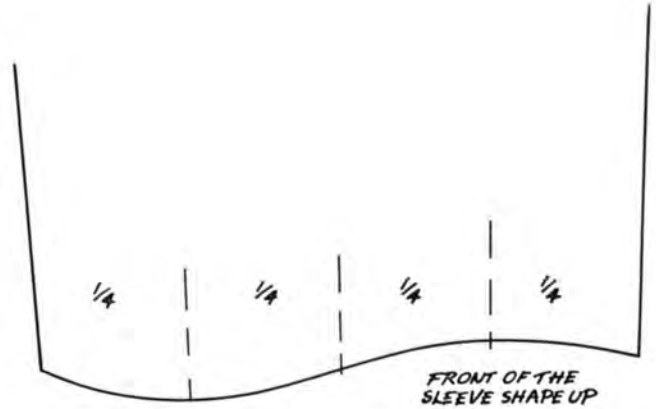

Position the cuff opening by dividing the sleeve into 4. The opening is usually to the back of the sleeve and is cut 2" - 3" long.

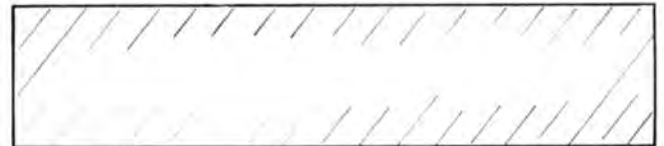

Cut two pieces of fabric twice the length of the opening and 1 1/4" wide. These can be cut on the straight bias grain.

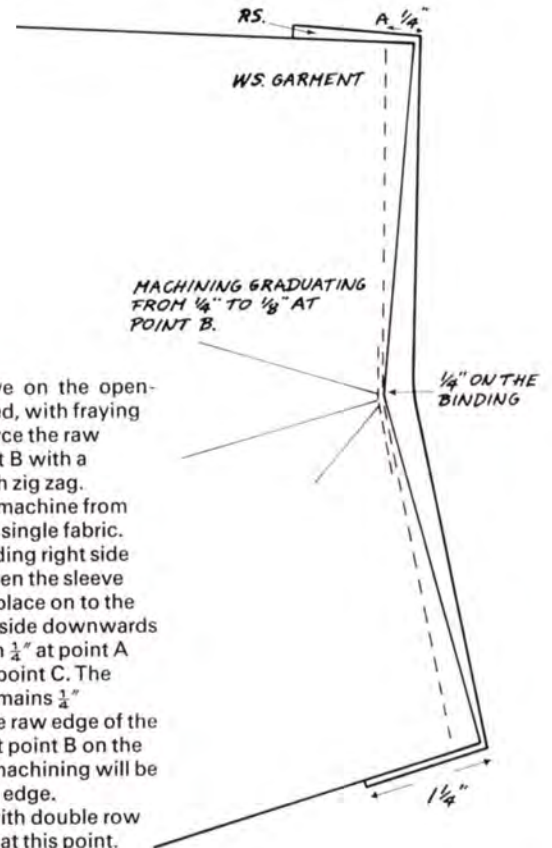

Cut the sleeve on the opening line marked, with fraying fabrics reinforce the raw edges at point B with a medium width zig zag. Alternatively machine from A.B.C. on the single fabric. Place the binding right side upmost. Open the sleeve opening and place on to the binding right side downwards. Machine from 1/4" at point A through B to point C. The machining remains 1/4" away from the raw edge of the binding but at point B on the garment the machining will be almost on the edge. Strengthen with double row of machining at this point.



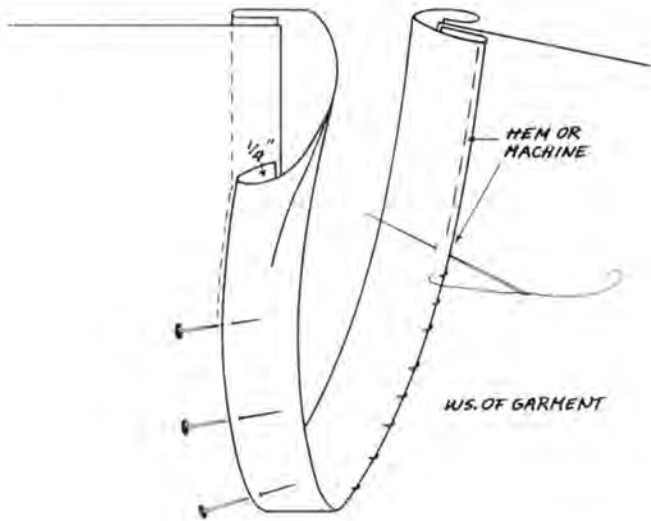

Press the binding into the opening. Fold over  $\frac{1}{4}$ " and pin to the machine line. Tack the hem.

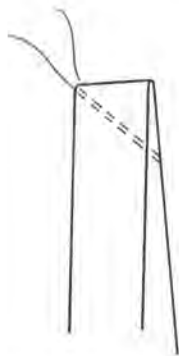

W. S. garment.  
Machine across the bindings as shown. This will eliminate any strain on this section.



R. S. garment. Fold the binding under on the front sleeve. Hold in place with tacking.

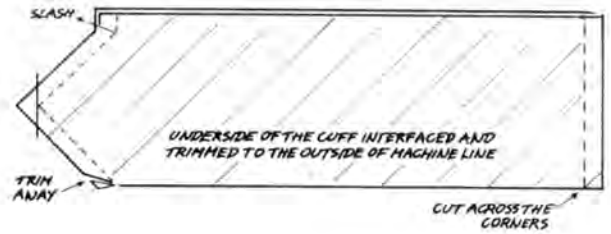

Machine the cuff, trim, turn through and press. Interface if necessary. Machine the sleeve seam.

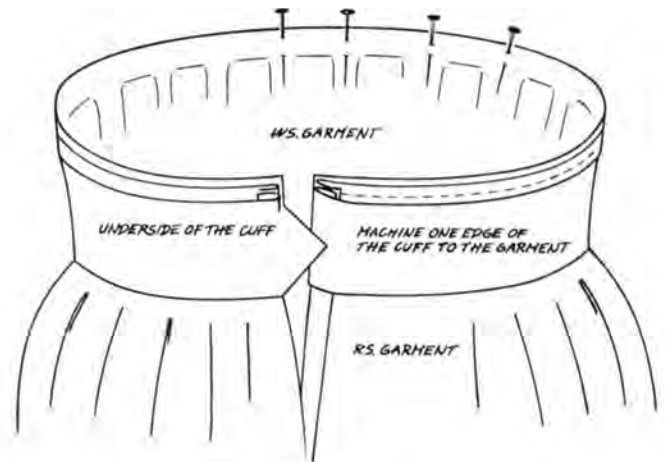

Pleat or gather the sleeve. Pin and tack to the cuff. Machine from the sleeve side using the free arm of the machine.

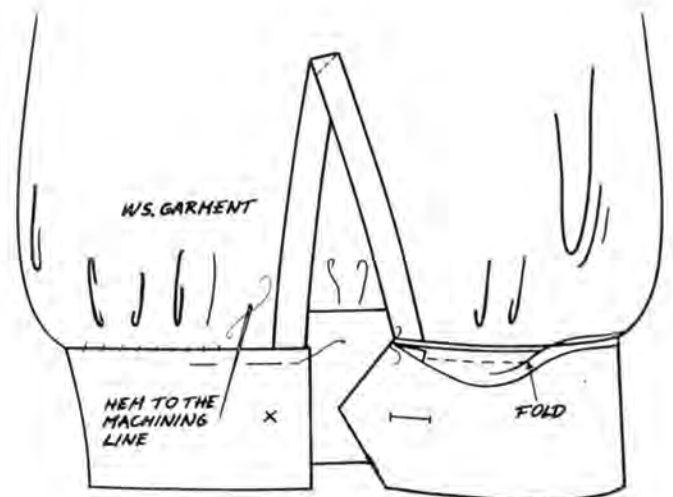

Turn to the inside. Fold in the raw edge. Tack and hem. Position the buttonhole, machine the buttonhole. Attach the button to the underside.





## INSERTING A ZIP— OVERLAP METHOD

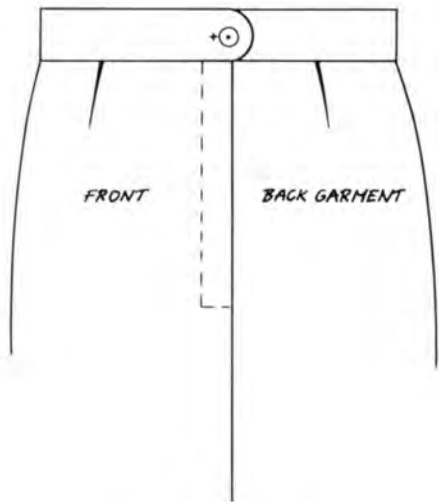

1. Prepare the zip opening. Tack the seams together on the fitting line.

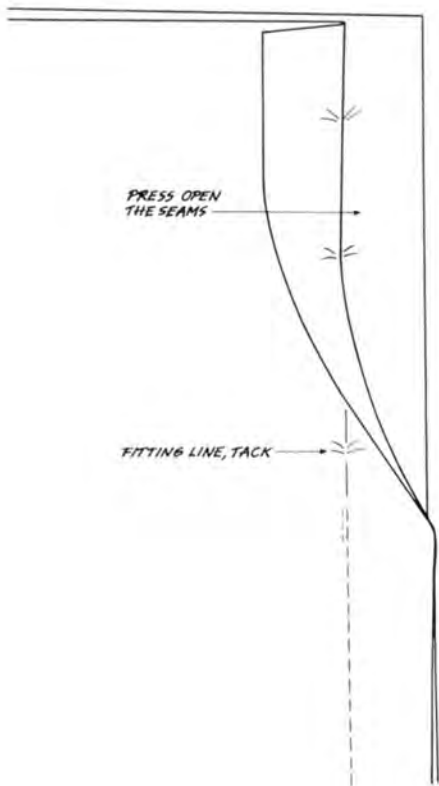

2. Machine the seam width up to the depth of the zip. Reverse to strengthen.

3. Remove the tacking threads. Open up the seam.
4. Pin and tack the folded edge of the underside up to the edge of the zip teeth.
5. Zips inserted in the left side of a garment overlap front over back using a zipper foot and starting from the base of the zip, machine close to the teeth.

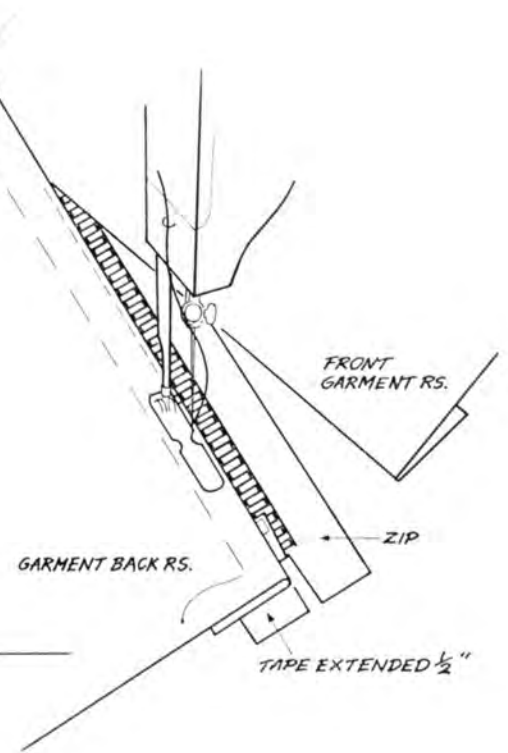
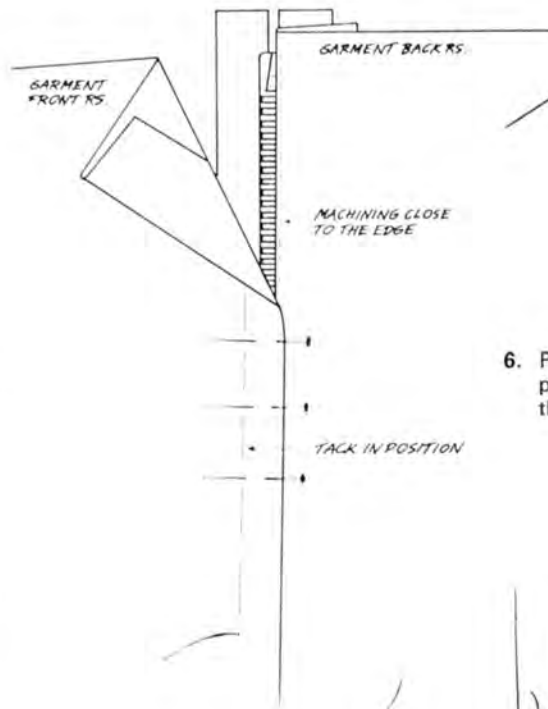

6. Pin the second side in position placing the folded edge to cover the 1st row of machining.

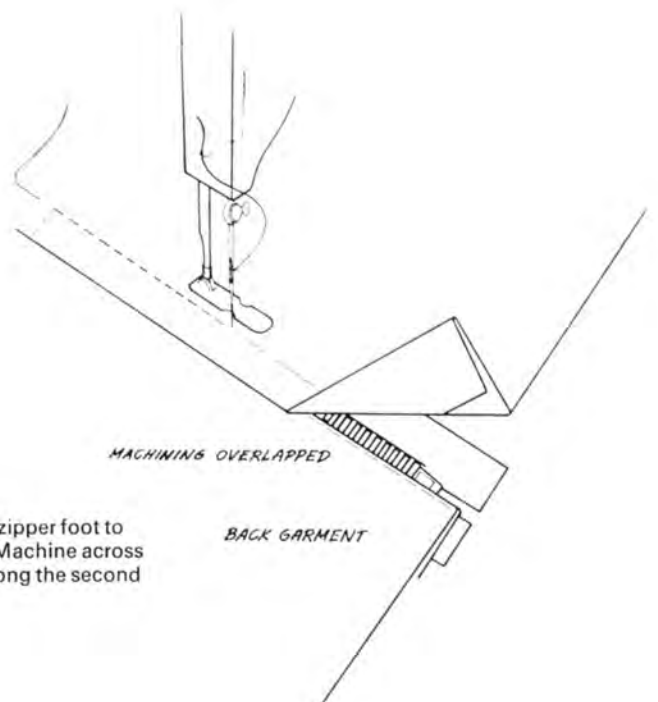

7. Reposition the zipper foot to the other side. Machine across the base and along the second side of the zip.





# INSERTING A SLEEVE

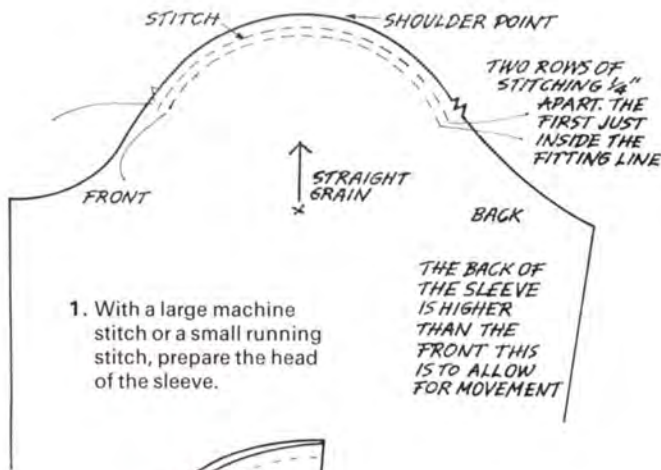

1. With a large machine stitch or a small running stitch, prepare the head of the sleeve.

THE BACK OF THE SLEEVE IS HIGHER THAN THE FRONT THIS IS TO ALLOW FOR MOVEMENT

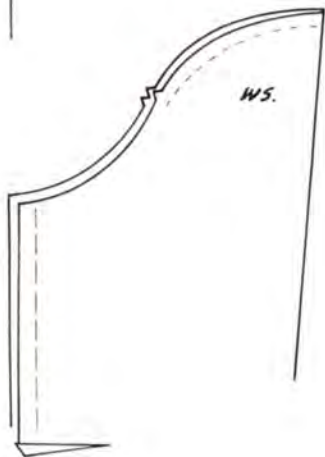

2. Machine the elbow dart and press downwards. Machine the underarm seam. Complete the cuff at this stage. Press the underarm seam open.

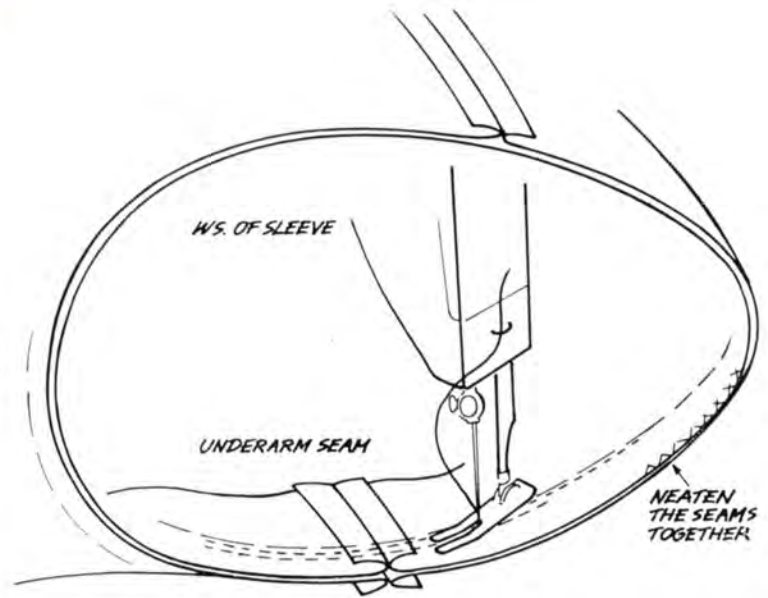

5. With the sleeve uppermost machine the sleeve into position, starting from 1"-1½" away from the underarm seam. Ease the gathers carefully under the machine. On completion of the circle continue the machining to the same distance to the other side of the underarm seam. This double row of machining will strengthen the sleeve against the strain of movement. Trim to ½" and neaten the seams together.

3. Pin into the sleeve spreading the gathers evenly 2"-3" either side of the shoulder point. Wrap the threads round a pin to secure.

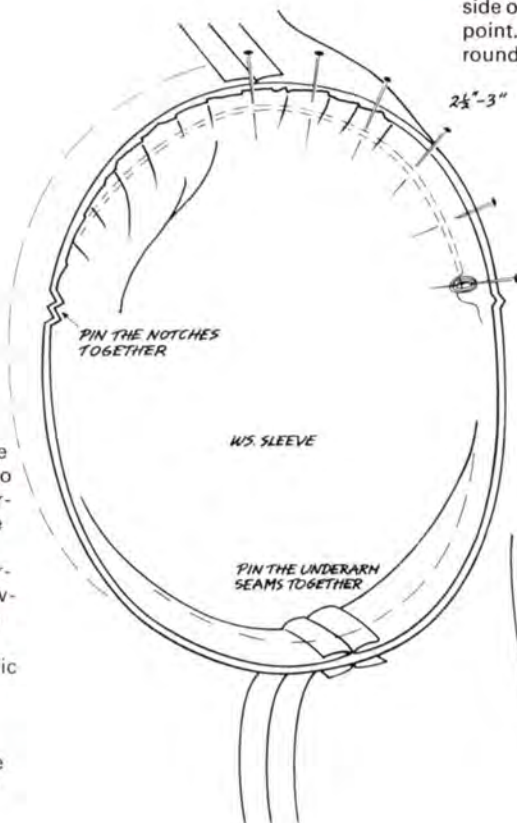

4. Holding the sleeve uppermost pin into position in the garment. Match at the shoulder points, notches and underarm seams by drawing up the running stitch. Spread the surplus sleeve fabric evenly either side of the shoulder point. Tack into position, check the hang of the sleeve at this stage.

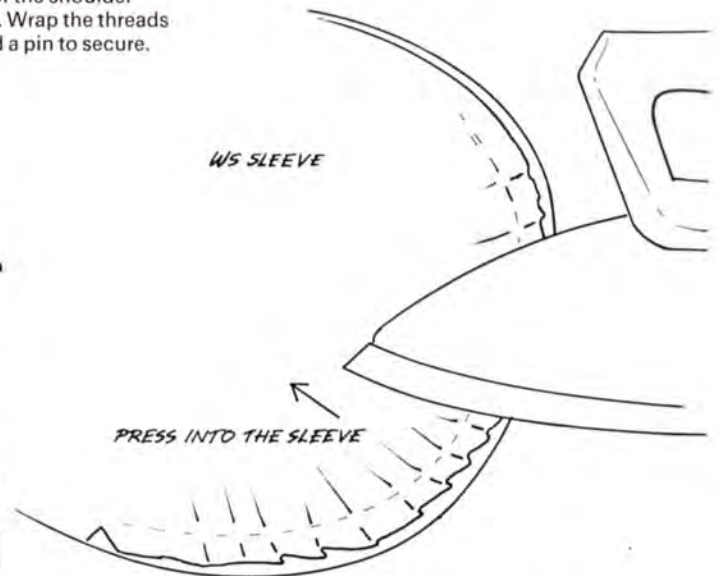

6. Using the point of the iron press into the sleeve holding the sleeve head over the sleeve board. With woollen fabrics the fullness can be shrunk before inserting the sleeve into the garment, by drawing up the gathering threads and with a damp cloth or a steam iron, pressing carefully with the point of the iron into the sleeve.



# ladies saddle shoulder dress

Ladies short sleeve saddle shoulder dress. Hand transfer lace pattern detail throughout eight panel skirt.

Trim fit on bust and hips with relaxed waist. Suitable for all makes of JONES machines.

## Materials

15 (16, 17) ozs. Jaeger Faerie Spun 2-ply. 4 inch zip. No. 12 crochet hook.

## Tension

8 sts. and 13 rows to 1 inch over stocking-stitch on T4. Check your tension very carefully.

## Measurements

To fit 32 (34 - 36) ins. bust.  
22 (24 - 26) ins. waist.  
34 (36 - 38) ins. hip.  
46 (47 - 48) ins. length from back neck to hem. (adjustable on skirt).  
5½ (6 - 6½) ins. sleeve seam.

## Abbreviations

T., tension; N., needle; st(s), stitch(es); K., knit; folls., follows; Trans., transfer; patt., pattern; pos., position; rep(s), repeat(s); ff5 trans. 5th st. to 6th N. and trans. 4 edge sts. to fill space pushing rem. empty edge N. to A pos.; beg., beginning; 000., set row counter to 000; dec., decrease; cont., continue; fin., finish(ing); Inc5., trans. 4 edge sts. out 1 N. push empty N. to pos. B; C.O.R., carriage on right; H.C.L's, holding cam levers; rem., remain(ing).

## Note

Instructions for the larger sizes are in (), where only 1 figure is given this applies to all sizes.

Two strands of wool are used together throughout for both the knitting and the crochet edges.

## Skirt Panels (8 alike)

T4. Cast on by hand over every N. 86 (88, 90) sts. K. 2 rows. Work trans. lace patt. throughout panels as folls.: Trans. 3rd st. to 4th N. at either end of work, leaving the 3rd N. in B pos. K. 4 rows. Rep. these 4 rows at same time ff5. each end of the next 10th row from beg. and then every foll. 10th row to 50 (52, 54) sts. (180 rows). 000. ff5. at each end of every foll. 9th row to 38 (40, 42) sts. (54 rows). 000. ff5 at each end of the foll. 32nd. and 64th. rows only. 34 (36, 38) sts. (length of skirt may be adjusted here). 000. K. 1 (7, 13) rows. 000. ff5. at each end of every foll. 19th row to 26 (28, 30) sts. (76 rows). K. 2 rows. With spare yarn K. a few rows and take work off machine.

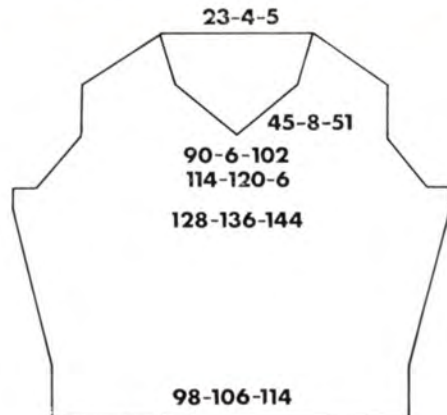
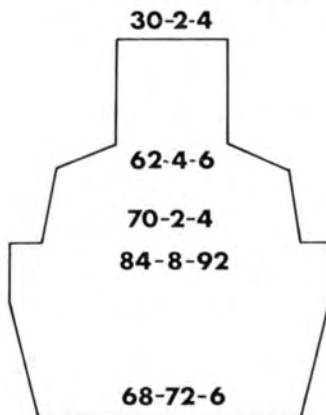



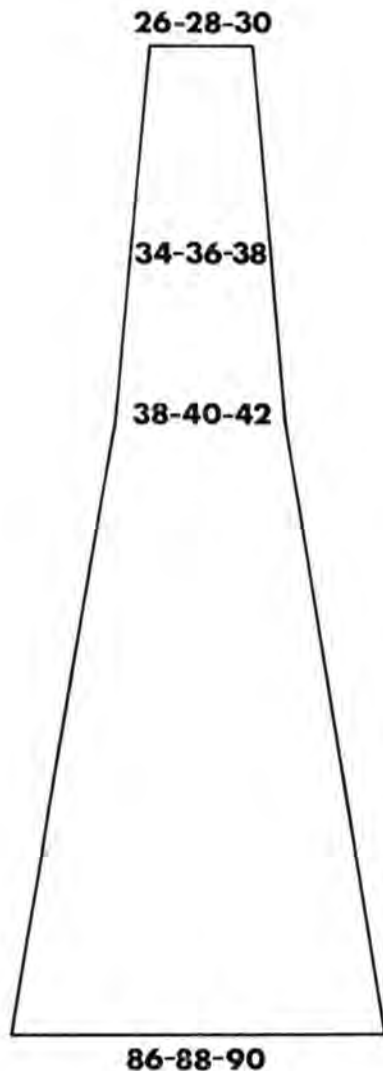

rows), at same time, still working trans. lace patt. on each edge and also cont. the centre large diamond from chart \*\* Fin. C.O.R.

#### Shape Neck

H.C.L's to III. Push left 45 (48, 51) sts. to E pos. 000. Cont. on right sts., ff5. every other row on neck edge 3 (4, 5) times, and then every row to 26 (28, 30) sts. and at the same time working trans. lace patt. on both armhole and neck edges. 22 (26, 30) rows. Fin. C.O.R.

#### Shape Shoulder

000. ff5. on neck edge on every foll. 6th row to 24 rows, at same time on shoulder edge ff5. every row to 22 (24, 26) rows, still working the trans. lace patt. on both shoulder and neck edges. Fasten off rem. st. H.C.L's to I. 000. Cont. on left sts. to match, reversing shapings.

#### Back

Work the same as the front to \*\* omitting all patterning on the centre seam after the skirt panels have been placed on to machine at \*\*\*\*.

#### Back opening

Note: work the trans. lace patt. on armhole and shoulder edges only throughout. H.C.L's to III. Push left 45 (48, 51) sts. to E pos. 000. Cont. on right sts. to 22 (26, 30) rows. Fin. C.O.R.

#### Shape Shoulder

ff5. every row on shoulder edge to 23 (24, 25) sts. 22 (24, 26) rows. Cast off. H.C.L's to I. 000. Cont. on left sts. to match reversing shapings.

#### Sleeves

T4. Cast on by hand over every N. 68 (72, 76) sts. K. 2 rows. 000. Cont. working the trans. lace patt. on each edge as before, and also working trans. lace patt. either side of the 2 centre sts. to match the patt. above the skirt seams on back and front until 3 reps. have been worked from beg. fin. with 4 rows K., then working from chart for

small diamond, and then cont., trans. lace patt. on each edge and in the centre as at beg., throughout the rem. of sleeve, at same time, Inc. 5 each end of every foll. 6th row to 84 (88, 92) sts. 48 rows. 000. Cont. straight to 26 (30, 34) rows fin. C.O.R.

#### Shape top

Cast off 7 (8, 9) sts. at beg. of the next 2 rows. 70 (72, 74) sts. 000. ff5. each end of every foll. 7th row to 62 (64, 66) sts. (28 rows). 000. K. 0 (4, 4) rows. 000. ff5. each end of every other row 0 (0, 4) times and each end of every row to 30 (32, 34) sts. 16 (16, 20) rows.

#### Saddle Strap

000. K. 46 (48, 50) rows. Cast off.

#### To Complete

Press work on wrong side with warm iron over damp cloth. Join saddle strap to front and back shoulders. Sew sleeve tops into armhole, sew sleeve and side seams, and panel seams. With hook work 1 row of double crochet on all edges including back opening.

#### Picot Edge

Work double crochet into the next 3 chains, double crochet into the next chain, then work 5 chains, then double crochet again into the same chain as last double crochet. Rep. this to end on skirt, sleeve and neck edges. Sew in zip. Press all seams.

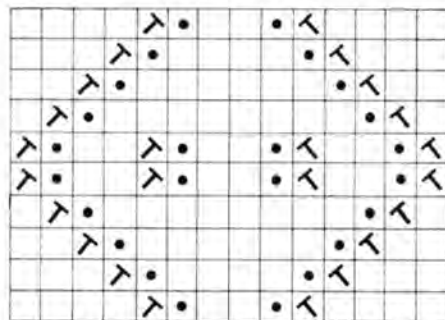

#### Front Bodice

Place 4 panels centrally on to machine, at same time dec. 1 st. on inside edges only on each panel thus making the edge panels to 25 (27, 29) sts. and the two centre panels to 24 (26, 28) sts. 98 (106, 114) sts. 000. Cont. working trans. lace patt. for the next 40 rows on both side edges and above the three skirt seams keeping the patt. in continuous sequence throughout fin. with 4 rows K. 000. Cont. working trans. lace patt. on both side edges and on the centre seam, still keeping the patt. in sequence, at the same time working the small diamond from chart knitting four rows between each trans. row on each of the two side front seams and also inc. 5 on the side edges on the next and then every foll. 5th row to 36 rows which completes the small diamond patt. Cont. working the centre large diamond from chart, knitting 4 rows between each trans. row, at the same time still working trans. lace patt. on both side edges, and still inc., as before, every 5th row, to 128 (136, 144) sts. (75 rows). Cont. straight, still working from chart for centre large diamond and working the trans. lace patt. on both edges to 92 rows.

#### Shape Armholes

Cast off 7 (8, 9) sts. at beg. of the next 2 rows. 114 (120, 126) sts. 000. ff5. each end of every other row to 90 (96, 102) sts. (24

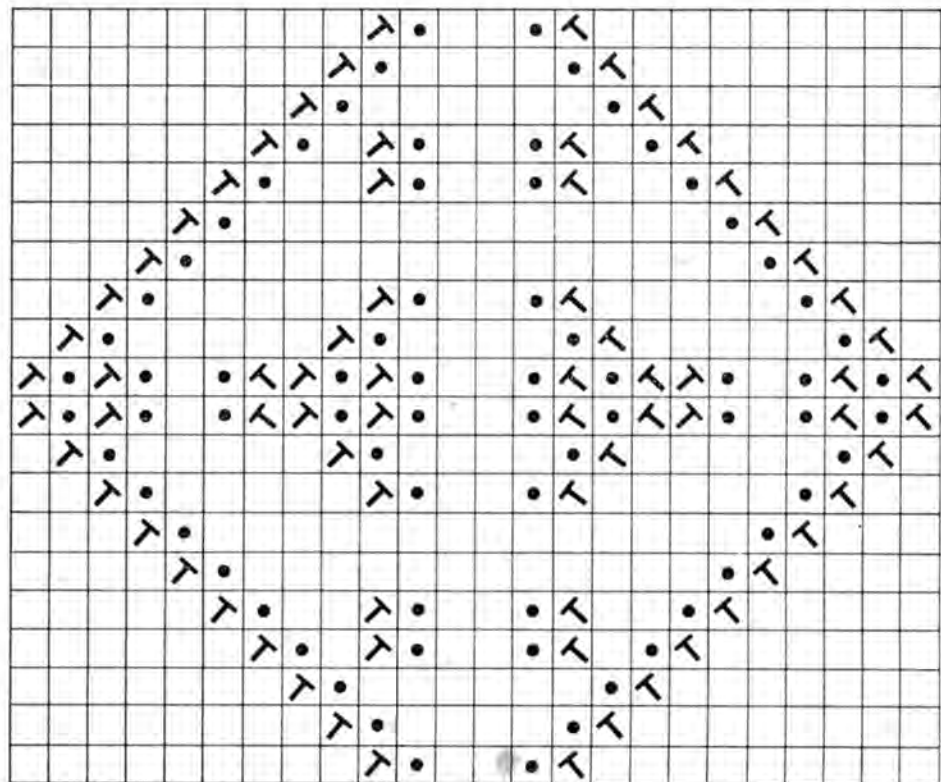



# ladies lacy twin-set



## Materials

Listers Lavenda Crisp Crepe 4 ply wool.

**Cardigan** 16 (17, 17, 18, 18) ozs.  
7 Buttons.

**Jumper** 13 (13, 14, 14, 15) ozs. 4 small buttons.

## Measurements

To fit bust sizes 36 (38, 40, 42, 44) ins.

**Cardigan** Finished measurements 38 (40, 42, 44, 46) ins.

Length to shoulder 21 $\frac{3}{4}$  (22, 22 $\frac{1}{4}$ , 22 $\frac{1}{2}$ , 22 $\frac{3}{4}$ ) ins. Sleeve seam 17 $\frac{1}{2}$  ins. all sizes.

**Jumper** Finished measurements 37 $\frac{1}{2}$  (39 $\frac{1}{2}$ , 41 $\frac{1}{2}$ , 43 $\frac{1}{2}$ , 45 $\frac{1}{2}$ ) ins. Length to shoulder 21 $\frac{1}{2}$  (21 $\frac{3}{4}$ , 22, 22 $\frac{1}{4}$ , 22 $\frac{1}{2}$ ) ins. Sleeve seam 3 ins (all sizes).

## Tension

12 sts. and 28 rows to 2 ins. after pressing.

## Abbreviations

Sts., stitches; inc., increase; dec., decrease; foll., following; beg., beginning; alt., alternate; S.D., slide dial; T., tension; 000, set row counter to 000. K., Knit.

## Notes

Figures in brackets refer to the larger sizes respectively.

**Bust shaping** Using odd length of wool, K. number of sts. given by hand and take each needle back to A pos.

## Welts and Cuff

**Ribbers** K. the number of rows given for 1 x 1 rib at T.3.

**Stocking stitch hem** K. double the number of rows given at T.6.

## CARDIGAN

### Back

Cast on 114 (120, 126, 132, 138) sts. K. 20 rows. (see notes). 000. T.7. Following lace chart with S.D. on 2 K. 168 rows. This will give a finished length to armhole of 14 ins. Adjust length here if required.

### Shape armholes

000. Cast off 3 (4, 4, 5, 5) sts. at beg. of next 2 rows. Dec. 1 st. at each end of next 5 (5, 7, 7, 9) rows then every alt. row until 88 (92, 96, 100, 104) sts. remain. K. straight until 108 (112, 116, 120, 124) rows have been worked.

### Shape shoulders

Cast off 6 sts. at beg. of next 8 rows and 3 (4, 5, 6, 7) sts. at beg. of next 2 rows. Cast off remaining 34 (36, 38, 40, 42) sts.

### Right front

Cast on 54 (57, 60, 63, 66) sts. having the extra st. on sizes 2 and 4 at right side. K. 20 rows. (see notes). 000. T.7. S.D. on 4 (3, 1, 8, 6). K. 155 rows. Carriage is at front edge. K. 1 row extra for Left Front. **Bust Darts** K. 4 sts. (see notes) at opposite side to carriage in next and alt. rows 7 times in all. K. 1 row. Unravel odd wool and bring needles to B. pos. K. the row (without

resetting needles that have been in A pos.). Following chart in the usual way K. 14 rows.

### Shape armhole

000. Cast off 3 (4, 4, 5, 5) sts. at beg. of next row. K. 1 row. Dec. 1 st. at armhole edge on next 5 (5, 7, 7, 9) rows then every alt. row until 41 (43, 45, 47, 49) sts. remain. K. straight until 77 (81, 85, 89, 93) rows have been worked.



**Shape neck**

Cast off 4 (5, 6, 7, 8) sts. at beg. of next row. K. 1 row. Dec. 1 st. at neck edge on next and every alt. row 5 times in all then every foll. 4th row 5 times.

**Shape shoulder**

Cast off 6 sts. at beg. of next and every alt. rows until 3 (4, 5, 6, 7) sts. remain. K. 1 row. Cast off.

**Left front**

Knit as Right Front reversing all shaping and set S.D. on 8 (2, 3, 5, 6). **Shaping darts** Unravel odd wool and bring needles to B. pos. Reset pattern in the usual way and knit.

**Sleeves**

Cast on 52 (54, 58, 60, 64) sts. K. 20 rows (see notes), 000. T.7. Following lace chart K. 14 rows. Inc. 1 st. at both ends of next and every foll. 12th row until there are 82 (84, 88, 90, 94) sts. K. straight until 218 rows have been worked. This will give a finished sleeve seam of 17½ ins. Adjust length here if required.

**Shape top**

000. Cast off 3 (4, 4, 5, 5) sts. at beg. of next 2 rows. Dec. 1 st. at each end of next and every foll. alt. rows 6 times in all then every foll. 4th row 9 (11, 10, 11, 11) times. K. 1 row. Dec. 1 st. at each end of next and every alt. row 5 (3, 6, 5, 7) times in all. K. 1 row. Cast off 3 sts. at beg. of next 4 rows and 4 sts. on next 2 rows. Cast off remaining 16 sts.

**Button band**

**Ribbers** Cast on 15 sts. for 1 x 1 rib. T.3/3. K. until long enough to fit up front less 1½ ins. Slip sts. on to a knitting needle.

**Single machines** Cast on 18 sts. by hand. T.5. K. until long enough to fit up front less 1½ ins. finishing at right side. Cast off 9 sts. and slip remainder on to a knitting needle.

**Buttonhole band**

Mark positions on Left Front for 7 buttonholes the first ½ in. above lower edge and allowing for the final one to come in the neckband. Space remainder evenly between.

**Ribbers** Cast on 15 sts. for 1 x 1 rib. T.3/3. K. straight and make buttonholes to match markers over 5 needles at centre. Slip sts. on to a knitting needle.

**Single machines** Cast on 18 sts. by hand. T.5. K. as for Ribbers making buttonholes over needles 4 to 6 inclusive from each end, finishing at left side. Cast off 9 sts. and slip remainder onto a knitting needle.

**Neckband**

Join shoulder seams. With wrong side facing and beg. at right side place 15 (9) sts. from buttonband on to machine, pick up 30 (31, 32, 33, 34) sts. up front neck, 33 (35, 37, 39, 41) sts from back neck, 30 (31, 32, 33, 34) sts. down front neck and 15 (9) sts. from buttonhole band.

**Ribbers:** Transfer all sts. to ribber for 1 x 1 rib. T3/3. K. 4 rows. Make a buttonhole as before at left side. K. 12 rows. Make a buttonhole. K. 4 rows, K 1 loose row. Transfer sts. to main bed and cast off using chain method.

**Single Machines:** T5. K. 4 rows. Make a buttonhole over needles 4 to 6 inclusive from left edge. K. 12 rows. Make a buttonhole as before. K. 4 rows. K. 1 loose row. Cast off using chain method.

**To Make Up**

Pin out and press with a hot iron over a damp cloth. Join side and sleeve seams. Sew in sleeves.

**Single Machines:** Turn hems at lower edge, cuff, neck and front bands to wrong side and slip stitch in place. Neaten buttonholes and sew on buttons. Press seams.

**Ribbers:** Sew front bands in position. Turn neckband to wrong side and slip stitch in place. Neaten buttonholes and sew on buttons. Press seams.

**JUMPER**

**Back**

Cast on 112 (118, 124, 130, 136) sts. K. 20 rows (see notes), 000. T7. Following lace chart with S.D. on 6. K. 168 rows. This will give a finished length to armhole of 14 ins. Adjust length here if required.

**Shape Armhole**

000. Cast off 3 (4, 4, 5, 5) sts. at beg. of next 2 rows. Dec. 1 st. at each end of next 5 (5, 7, 7, 9) rows then every alt. row until 86 (90, 94, 98, 102) sts. remain.\* Knit straight until 58 rows have been worked.

**Divide for opening:** Using odd wool knit 43 (45, 47, 49, 51) sts. at left by hand taking needles down to A position. Knit on remaining sts. Knit straight until 104 (108, 112, 116, 120) rows have been worked.

**Shape shoulder**

Cast off 6 sts. at beg. of next and alt. rows 4 times in all and 2 (3, 4, 5, 6) sts. on foll. alt. row. K. 1 row. 17 (18, 19, 20, 21) sts. remain.

**Ribbers:** Transfer all sts. to ribber for 1 x 1 rib. T3/3. K. 18 rows. K. 1 loose row. Transfer sts. to Main bed and cast off using chain method.

**Single machine:** T6. K. 18 rows. K. 1 loose row. Cast off using chain method. Unravel odd wool and bring needles to B position. Knit to match first side reversing shapings.

**Front**

Knit as back to \*. Knit straight until 74 (78, 82, 86, 90) rows have been worked. Using odd length of wool cast off 14 (16, 18, 20, 22) sts. at centre. With odd wool knit sts. at left and take needles down to A position. Knit on remaining 36 (37, 38, 39, 40), sts. K. 1 row. Dec. 1 st. at neck edge on next and every alt. rows 5 times in all, then every foll. 4th row 5 times in all.

**Shape shoulder**

Cast off 6 sts. at beg. of next and alt. rows until 2 (3, 4, 5, 6) sts. remain. K. 1 row. Cast off. Unravel odd wool and bring needles to B position. Knit to match first side reversing shapings.

**Sleeves**

Cast on 64 (66, 70, 72, 76) sts. K. 8 rows. (see notes), 000. T7. Following lace chart with S.D. on 2 K. 4 rows inc. 1 st. at each end of next and every foll. 4th row until 78 (80, 84, 86, 90) sts. Knit straight until 36 rows have been worked.

**Shape top**

000. Cast off 3 (4, 4, 5, 5) sts. at beg. of next 2 rows. Dec. 1 st. at each end of next and every foll. alt. row 4 times in all then every foll. 4th row 9 (11, 10, 11, 11) times. K. 1 row. Dec. 1 st. at each end of next and alt. rows 6 (4, 7, 6, 8) times in all. K. 1 row. Cast off 3 sts. at beg. of next 4 rows and 4 sts. on next 2 rows. Cast off remaining 14 sts.

**Neckband**

With wrong side facing pick up and place on machine 26 sts. down front neck, 14 (16, 18, 20, 22) sts. across front neck, 26 sts. up other side. 66 (68, 70, 72, 74) sts. K. 1 row.

**Ribbers:** Transfer alt. sts. to ribber for 1 x 1 rib. T3/3. K. 18 rows. K. 1 loose row. Transfer sts to Main Bed and cast off using chain method.

**Single Machines:** T5. K. 18 rows. K. 1 loose row. Cast off using chain method.

**To Make Up**

Pin out and press with a hot iron over a damp cloth. Join side, shoulder and sleeve seams. Sew in sleeves. Turn neckband to wrong side and slip stitch in place. Work 2 rows of crochet round opening making 4 loops on one side of second row.

**Single Machines:** Turn hem at lower edge and cuffs to wrong side and slip stitch in place. Press seams.

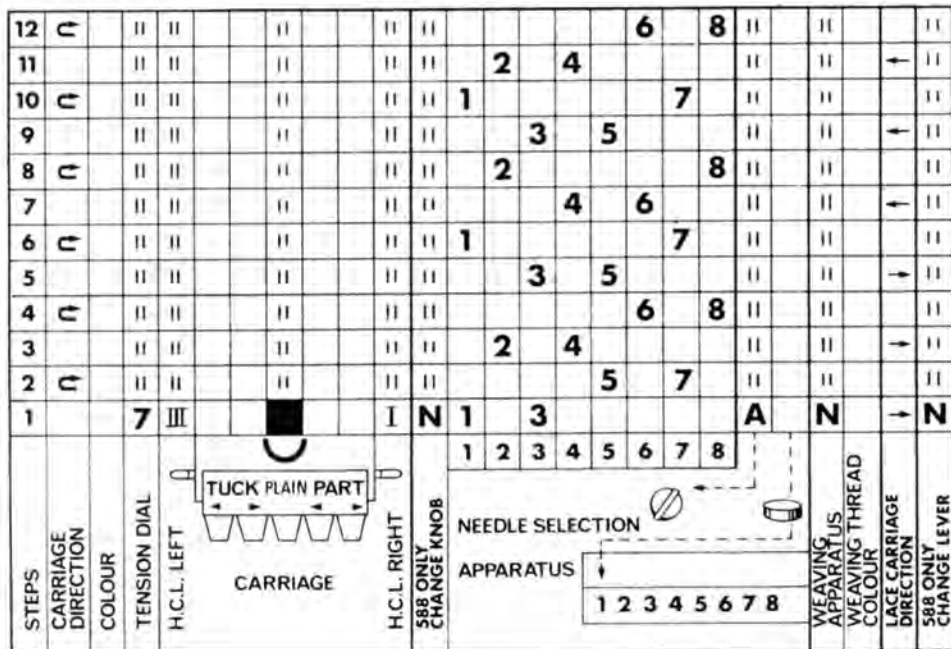





From: **Mr. Walker, 14A Ringford Crescent, Belfast, N. Ireland. BT11 9LG.**

Another little tip for *Stitchin' time* readers. What to do with the big cast-on comb when not in use. Turn empty table (Brother machine table) upside down A. space 40" long x 4½" wide. The comb is only 36" long. Lay the comb flat on this space. With clips flat and mark through holes in clip. Do the same with small comb spacing. The 2 combs in the 4½" space. Now screw in 4 large sized cup hooks. Be careful not to screw in too far to come through top of table. Turn the left-hand screw slightly to left, and right hand to the right. If put in close enough the front will be wide enough to let the comb in but back will be too close to let it slip out at the back. Also while you are at it put a cup hook near end and as near the front as possible. Tie 2 bulldog paper clips on these hooks. Then if you ever require a handy holder for the end of your wool just open the bulldog and slip it in.

*Editor: Thanks for a good idea.*

From: **Mrs Boyton, Bridgwater.**

Dear Sir,

I have been following the Sew Easy Course with interest, but wish you would explain a little more how to use the different feet on the machine as I am very disappointed with the instruction book, as it gives no details of these accessories.

*Editor: Thank you for your comment. We will be doing something of this in a future issue as other customers have requested this. In fact we hope to get it in either the next issue or the one immediately after that.*

From: **Mrs. Davies, Newcastle.**

Dear Sir,

In a much earlier issue, you announced

that you would be having basic shapes ready and I have been waiting patiently for these. How much longer must I wait?

*Editor: These basic shapes are now available. We apologise for the long delay in getting them ready. However, basic shapes are for raglan sleeves, cardigans and jumpers from 20 inch to 50 inch chest, with both round and vee necks. They cost 40p plus 5p postage and are available from this office:-  
Britannia House,  
964, High Road,  
Finchley,  
London, N.12*

From: **Mrs. Brawn, Worcester.**

Dear Sir,

I have followed the instructions carefully, in the ribbing attachment book, but consider the cast-on edge too loose and should like to know how to make it tighter.

*Editor: The best way to do this is to cast on with some waste yarn and knit three or four rows and then knit one row with the nylon cord supplied with the machine, then repeat the first four rows exactly as if you were casting on, that is one row normal knitting and then three rows in circular and then continue to knit the garment and if you have finished, by pullidg hard on the nylon thread, the waste yarn can be removed and you will have a neat edge.*

*By experimenting with the tension you will find the ideal method for different ply wools.*

From: **Mrs. Boyle, Lancaster.**

Dear Sir,

I have greatly enjoyed the *Stitchin' time* magazine and look forward to receiving it.

Can you please include more ribbing attachment patterns as I have recently purchased a ribbing attachment, and want to make use of it.

*Editor: Thank you for your kind remarks about the magazine.*

*We are in the process of preparing a booklet of all previous ribbing attachment patterns which have appeared in *Stitchin' time* and we will announce this as soon as it is available.*

*You will have noticed from the last two issues, that we are definitely making an effort to include a pattern for the ribbing attachment and at least one weaving and one fairisle pattern.*

From: **Mrs. P. Collins, Wrexham.**

Dear Sir,

I have a 585 knitting machine, and I have purchased a two guinea book. This book, however, appears to be for the 588 machine.

Can you please tell me if I can exchange it for the correct book.

*Editor: The 585 book has been discontinued and now only the 588 book is available. However, it is very easy to convert as the only difference on the machine is the fairisle patterning. On the 585, two movements of the cam box are necessary for one row of fairisle, where as on the 588 only one row is necessary.*

*Therefore when reading, the 588 pattern book, you must do two steps for each of the steps given on the chart. If you have a 585. On the first step you must have your reverse-dial on A and then you must have it on B and change to the contrast colour yarn. (Two steps for one row)*







## RIGHT FRONT

Using M only cast on 89 (93, 98, 102, 107, 111) sts. (with extra st. on right side) by hand. T5. Knit 14 rows 000. S.D. on 2 (1, 7, 6, 5, 4). Following chart knit 16 rows. Dec. 1 st. at right side on next and every following 16th row 4 times in all. 85 (89, 94, 98, 103, 107) sts. Knit straight for 15 rows. 80 rows. Mark right side with contrast wool. Inc. 1 st. at right side on next and every following 18th row until there are 89 (93, 98, 102, 107, 111) sts. Knit straight until 146 rows have been worked.

### Shape armhole and front edge

000. Inc. 1 st. at left side (front edge) on next and every following 8th row 5 times in all, at the same time cast off 6 sts. at beg. of next row. Knit 1 row. Dec. 1 st. at armhole edge on next 5 rows then every following alt. rows 4 (4, 5, 5, 6, 6) times. Keeping armhole edge straight knit until 40 rows have been worked. Inc. 1 st. at right side on next and every following 8th (8th, 10th, 10th, 12th, 12th) row 5 times in all. At the same time inc. 1 st. at left side on next and following 8th row. 83 (87, 90, 94, 98, 102) sts. Knit 2 (4, 8, 10, 8, 8) rows. 5th and 6th sizes. Inc. 1 st. at left side on next row 100 (104) sts. Knit 4 (6) rows.

**All sizes.** Continuing armhole shaping, dec. 1 st. at left edge on next 7 (7, 7, 7, 8, 8) rows. Carriage is at right. Counting from left side and using odd length of wool cast off sts. 17 to 40 (42, 44, 46, 48, 50) inclusive. Slip sts. at left onto a knitting needle. Knit 1 row. Dec. 1 st. at neck edge on next and every following alt. row 5 times in all. Keeping neck edge straight continue armhole increasing until there are 34 (36, 38, 40, 42, 44) sts. Knit straight until 80 (82, 86, 88, 92, 94) rows have been worked.

### Shape shoulder

Cast off 6 (6, 6, 6, 7, 7) sts. at beg. of next and alt. rows until 4 (6, 8, 5, 7, 9) sts. remain. Knit 1 row. Cast off. Replace sts. on machine. Rejoin wool at neck edge (right side). Dec. 1 st. at left side on every row at the same time dec. 1 st. at neck edge on every following alt. rows 4 times. Dec. 1 st. at left side on next row. 3 sts. remain. Cast off.

## LEFT FRONT

Using M only cast on 73 (77, 82, 86, 91, 95) sts. (with extra stitch on right side) by hand. T5. Knit 14 rows. 000. S.D. on 4 (5, 6, 7, 1, 2). Following chart knit 17 rows. Dec. 1 st. at beg. of next and every following 16th row 4 times in all 69 (73, 78, 82, 87, 91) sts. Knit straight for 15 rows. 80 rows. Mark left side with contrast wool. Inc. 1 st. at left side on next and every following 18th row until there are 73 (77, 82, 86, 91, 95) sts. Knit straight until 147 rows have been worked.

### Shape armhole

000. Cast off 6 sts. at beg. of next row. Knit 1 row. Dec. 1 st. at armhole edge on next 5 rows then every following alt. row 4 (4, 5, 5, 6, 6) times 58 (62, 66, 70, 74, 78) sts. Knit straight until 40 rows have been worked. Inc. 1 st. at beg. of next and every following 8th (8th, 10th, 10th, 12th, 12th) row until 57 (59, 63, 65, 69, 71) rows have been worked.

### Shape neck

Continuing armhole shaping cast off 24 (26, 28, 30, 32, 34) sts. at beg. of next row. Knit 1 row. Dec. 1 st. at neck edge on

next and every following alt. row. 5 times in all. Keeping neck edge straight continue armhole increasing until there are 34 (36, 38, 40, 42, 44) sts. Knit straight until 80 (82, 86, 88, 92, 94) rows have been worked.

### Shape shoulder

Cast off 6 (6, 6, 7, 7, 7) sts. at beg. of next and alt. rows until 4 (6, 8, 5, 7, 9) sts. remain. Knit 1 row. Cast off.

## SLEEVES

Using M. only cast on 57 (61, 65, 69, 73, 77) sts. (with extra st. on right side) by hand. T5. Knit 14 rows. 000. Following chart knit 10 rows. Inc. 1 st. at each side of next and every following 10th row until there are 91 (95, 99, 103, 107, 111) sts. Knit straight until 188 rows have been worked. This will give a finished sleeve seam of 17 ins. Adjust length here if required.

### Shape top

Cast off 5 sts. at beg. of next 2 rows. Dec. 1 st. at each side of next 5 rows, then every following alt. row 4 times. Knit 3 rows. Dec 1 st. each side of next and every following 4th row 3 times in all then every following alt. row 6 (6, 6, 8, 8, 8) times. Dec. 1 st. each side on next 6 (8, 10, 8, 10, 12) rows. Knit 1 row. Cast off 3 sts. at beg. of next 6 rows. Cast off remaining 15 (15, 15, 19, 19, 19) sts.

### To make up

Pin out and press with a hot iron over a damp cloth. Join side, shoulder and sleeve seams. Sew in sleeves. Turn hem at lower edge and cuffs to wrong side and slip-stitch in place. Work 3 rows of crochet up both fronts and round neck. Sew 3 press studs on inside of Right Front, then sew buttons on top. Sew remaining 3 press studs on Left Front to correspond with Right Front. Press seams.

## SKIRT

### BACK AND FRONT ALIKE

Using M only cast on 129 (137, 143, 151, 157, 165) sts. (with extra st. at right side) by hand. T5. Knit 14 rows. 000. Following chart knit 144 (144, 150, 150, 154, 154) rows. This will give a finished length of 21 (21, 21½, 21½, 22, 22) ins. Adjust length here if required. Mark ends with contrast wool.

### Shape to waist

Dec. 1 st. at each end of next and every following 8th row 6 times in all then every following 4th row until 101 (109, 115, 123, 129, 137) sts. remain. Knit straight until 222 (222, 228, 228, 232, 232) rows have been worked.

**Ribbers.** Transfer every alt. needles to ribber for 1×1 rib. T4/4. Using M only knit 10 rows. Knit 1 loose row. Transfer sts. to main bed and cast off using chain method.

### Single machines

T5. Using M only knit 10 rows. Drop alt. sts. and crochet up as for 1×1 rib. Cast off. **Alternatively.** Slip sts. onto No. 11 knitting needles and work 10 rows in k.1 p.1 rib. Cast off in rib.

### To make up

Pin out and press with a hot iron over a damp cloth. Join side seams. Turn hem at lower edge to wrong side and slip-stitch in place. Cut elastic to fit waist. Join into a ring, hold inside waistband and work a herringbone st. over elastic onto every alt. st. of ribbing. Press seams.

## STOP PRESS—

### 3 MORE JONES CLUB ADDRESSES

#### SOUTH SHIELDS

Mrs. P. McTaggart,  
33 Salmon Street, South Shields.  
Old Civil Defence H.Q., Anderson Street,  
Soth Shields. Start: 7.30 p.m.  
September 3rd; October 1st;  
November 5th; December 3rd.

#### TUNBRIDGE WELLS

Mrs. Springett,  
53 Cranwell Road, Rusthall, Tunbridge Wells.  
Congregational Church Hall, York Road,  
Tunbridge Wells. Start: 7.30 p.m.  
September 27th; October 25th;  
November 29th.

#### WOLVERHAMPTON

Mrs. Marston,  
Beatties Ltd., Wolverhampton.  
Darlington Street Methodist Church,  
Wolverhampton. Start: 7.30 p.m.  
September 1st; October 6th;  
November 3rd; December 1st.

## Stitchin' Link

A reminder to our readers regarding the Stitchin'Link scheme, which has been in operation since May of this year.

If you would like to exchange ideas and experience with another machine owner by post, please write initially to Finchley and we will link you with another Member in a different part of the country.

We think this scheme will prove of particular interest during the Autumn and Winter months, and hope that many of our readers will wish to participate.

Please complete this form and paste on the back of your Photograph.

Name .....

Address .....

Time taken to knit garment .....

Type of stitches.....

Type of wool used.....

Name of model .....

Age (if child) .....

Photographs (black and white) must be sharp and clear and not less than 10 in. x 8 in. Closing date of the Competition December 20th, 1971.



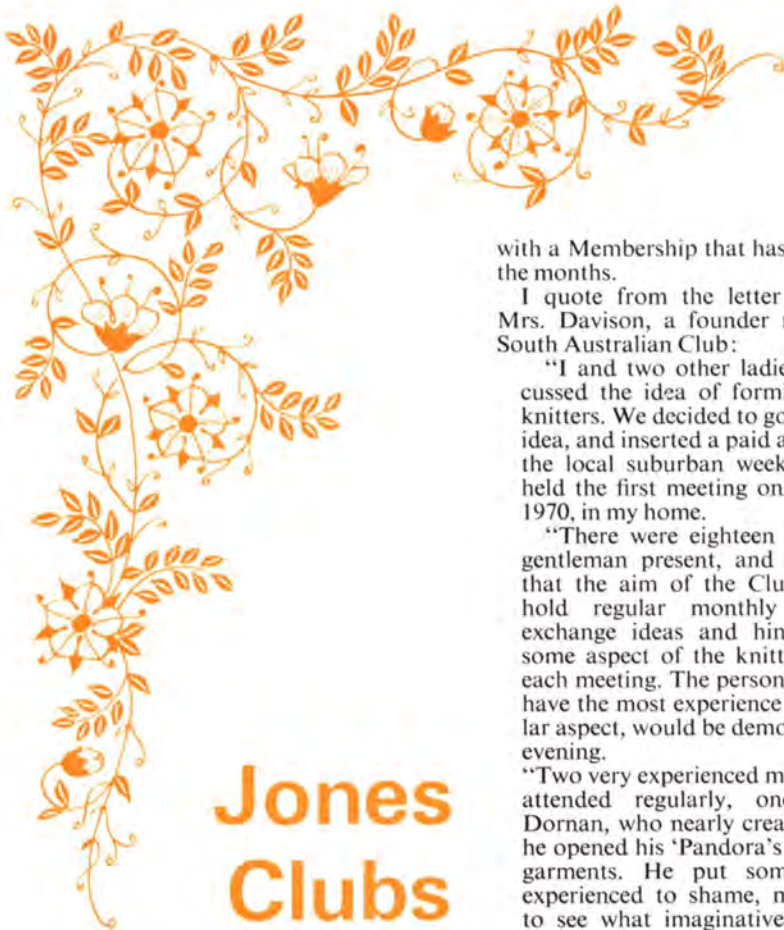

## Jones Clubs

Only one or two Clubs have kept their doors open during the Summer break – one being the Blackpool Club, whose venue has been a hotel along the Promenade. On the doorstep of such bright attractions, it would have been a pity not to have continued meetings during the summer, and Mrs. Beaumont, our Blackpool Club Secretary, has been welcoming guests and visitors throughout the summer.

As you will see, we are including forthcoming Club dates on this page, from September – December, and these will be given again in all future issues. It is important to remember, however, that since programme details cannot be included here, members should watch local papers and also keep in touch with Club Secretaries if necessary, to keep abreast of extra programme items.

We are trying to arrange additional programme items well in advance, so announcements can be made at Club meetings; but do watch your local newspapers and Jones Departments.

One point we have to make – we have not been able to print all Club dates since at the time of going to Press, not all the halls are booked. Therefore, if you cannot find your Club on this page and wish to know details, please contact Finchley.

**CLUB DOWNUNDER . . .** A pleasant surprise emerged earlier in the summer, when we discovered a new Club whose doors have been open since February . . . but several thousand miles away from these shores. Held in Adelaide, South Australia, it has been pioneered by three ladies whose enthusiasm for machine knitting has led to the formation of a Jones Club of their own,

with a Membership that has expanded over the months.

I quote from the letter received from Mrs. Davison, a founder member of the South Australian Club:

"I and two other ladies met and discussed the idea of forming a Club for knitters. We decided to go ahead with the idea, and inserted a paid advert in four of the local suburban weekly papers, and held the first meeting on the 26th May, 1970, in my home.

"There were eighteen ladies and one gentleman present, and it was decided that the aim of the Club would be to hold regular monthly meetings, to exchange ideas and hints and feature some aspect of the knitting machine at each meeting. The person who seemed to have the most experience in that particular aspect, would be demonstrator for the evening.

"Two very experienced male knitters also attended regularly, one being John Dornan, who nearly created a riot when he opened his 'Pandora's Box' of knitted garments. He put some of the less experienced to shame, myself included, to see what imaginative work a 'mere male' could do! But it did help to inspire more confidence into us, to think that perhaps we could turn out similar garments with practice."

From February of this year, the Club has moved to a local hall and as Mrs. Davison pointed out in her letter, Club Members are doing all their own ground-work without the aid of a distributor, and all work is voluntary.

We understand that this Club is the first of its kind in Australia, but already there have been discussions in regard to forming other Clubs in surrounding suburbs. We hope to have more news in future issues as to the progress of our overseas friends, together with photographs, and in the meantime we would like to wish them well with all their future plans and activities.

As a footnote, Mr. John Dornan expressed interest in the 'Stitchin' link scheme which we are currently running for British Members, and perhaps in the future we might be able to encourage correspondence between British and overseas 'Stitchin' time Members.

**MOVING ON . . .** We can't guarantee to take you as far as Australia – but Clarksons have promised some great alternatives! Recent talks with their Sales Manager have confirmed that we will be presenting further holiday offers to Clubs, next Season.

You may remember that last Season, the special low-price holiday offer was for Holland, but we understand the choice is not to be restricted, and in fact other destinations may be selected by each Party. **WOOLMARK . . .** When arrangements have been completed, we hope a number of Midland Clubs will be receiving a talk from a member of the International Wool

Secretariat, who has most kindly agreed to give talks to the Midland Clubs next Season on all aspects of wool and the wool industry.

**TOBY TEABOY . . .** An additional item of interest to Members and guests will be included at meetings in the autumn. The 'Toby Teaboy' is a brand-new product manufactured by the Toby Holloware Company, and presents a unique money-saving method of making tea and coffee. Our Members will not only have the opportunity of sampling refreshments made the 'Toby Teaboy' way but will also be able to produce this handy gadget for themselves.

Our Club Secretaries will be receiving a sample of the 'Toby Teaboy' to test for themselves, with a covering letter from the manufacturer. We hope that our Members will then be able to order this new product at Club meetings, during the Season.

**TUNE IN . . .** We have been inundated by requests for T.V. Show tickets and although the B.B.C. have temporarily closed their lists, the Commercial companies are still accepting bookings. However, since the idea seems to be popular, we have turned our thoughts to an alternative.

There are some very entertaining radio comedy shows for which tickets can be obtained, and the B.B.C. have told me that audiences are welcome at regional studios throughout the country. Therefore, if you would like to organise an outing of this nature, we shall try to book seats for a radio show within your region.

**COMPETITION . . .** Entries are still coming in for our knitting and Photography competition announced in the last issue and so we have decided to extend the closing date until 20th December. There are 101 prizes to be won, including a fabulous first prize of a Knitleader attachment, and an entry form for the competition is included Page 29 for your use.

As a footnote to Club Secretaries, we should like to introduce a new member of our staff who joined the Jones Club Department earlier in the summer. She is Miss Carole Bishop who will be looking after patterns and books for the Clubs in future, and she will also be glad to help you with any queries or requests for information that you may have.

Finally, we are continually striving to give our Members more and more good reasons for enjoying their Jones Club Membership, and we think that this Season will prove another step in the right direction. We would therefore like to wish all of you – particularly our new Members – a very enjoyable Season of Jones Clubs.

Beverly  
Martin



Club Secretary:	Venue	Dates
<b>AYR</b> Mrs. J. Macdonald, 5 Coronation Street, Monkton, Ayrshire.	The Station Hotel, The Station, Ayr. Start: 7.30 p.m.	September 7th; October 5th; November 2nd; December 7th.
<b>BIRMINGHAM</b> Mrs. D. Taylor, Birmingham Knitting Centre, 1st Floor, Somerset House, Temple Street, Birmingham 2.	The Alston Suite, Post Office Social Club, Thorp Street, Birmingham 5. Start: 7.30 p.m.	September 1st; October 6th; November 3rd.
<b>BRIGHTON</b> Mrs. E. Whitaker, Bristol Lodge, Bristol Gate, Brighton, Sussex.	10 Hillside, Moulscoombe, Brighton, Sussex. Start: 6.30 p.m.	September 27th; October 25th; November 29th; December 27th;
<b>BRISTOL</b> Mrs. J. Bolwell, Ivanhoe Lodge Lane, Wraxhall, Nr. Bristol BS19 1BQ.	Quakers Hall, Gloucester Road, (Cnr. Radnor Road), Bristol. Start: 7.00 p.m.	September 8th; October 8th; November 3rd; December 1st
<b>BROMLEY</b> Mrs. G. Dalton, 13 New Farm Avenue, Bromley, Kent.	The Soames Room, St. Marks Hall, Masons Hill, Bromley, Kent. Start: 7.45 p.m.	September 7th; October 5th; November 2nd; December 7th.
<b>BLACKPOOL</b> Mrs. Beaumont, 5 Scarborough Road, St. Annes-on-Sea, Lancs.	Highlands Hotel, Promenade, Bispham, Blackpool. (Opp. Red Bank Road Tram Stop).	No Sept. meeting; October 25th; November 22nd; December 13th. Start: 8.00 p.m.
<b>CHICHESTER</b> Mrs. E. G. Parker, 118 Oving Road, Chichester, Sussex.	118 Oving Road, Chichester, Sussex. start: 6.30 p.m. This Club meets once a fortnight.	September 2nd; September 16th; September 30th; October 14th; November 11th; November 25th; December 9th.
<b>CHRISTCHURCH</b> Mrs. Turner, 25 Queen Road, Christchurch, Hants.	N.A.D.'s Club, Bridge Street, Christchurch. Start: 7.30 p.m.	September 15th; October 20th; November 17th; December 15th.
<b>DERBY</b> Mrs. A. Buchan, 287 Uttoxeter Road, Mickleover, Derby.	Large Club Room, The Guildhall, Market Place, Derby. Start: 7.30 p.m.	First meeting: October 26th.
<b>DONCASTER</b> Mrs. Ramage, Owen Owen Ltd., Doncaster.	Owen Owen Ltd., (Fabric Department), 13/14 Baxtergate, Doncaster. Start: 7.30 p.m.	September 13th; October 20th.
<b>DURHAM</b> Mrs. Keefe, 16 Marlene Avenue, Bowburn, Durham.	Shakespeare Hall, North Road, Durham City. Start: 7.00 p.m.	September 14th; October 26th; November 23rd.
<b>EMSWORTH</b> Mrs. Whittington, 37 Clovelly Road, Southbourne, Nr. Emsworth, Hants.	Chidham Village Hall, Main Road, Nutbourne, Nr. Chichester. Start: 7.30 p.m.	September 22nd; October 20th; November 17th; December 15th.
<b>GT. YARMOUTH</b> Mrs. N. Scott, Jones Demonstrator, Arnolds Limited, King Street, Gt. Yarmouth.	31 Northgate Street, Gt. Yarmouth. Start: 7.30 p.m.	November 2nd; December 7th.
<b>HARROW</b> Mrs. Janes, 6 Kingsway Crescent, North Harrow, Middx.	North Harrow Assembly Hall, Station Road, N. Harrow HA2 6BG Start: 8.00 p.m.	September 24th; October 29th; December 3rd.
<b>HULL</b> Mrs. E. Parrott, 16 Westcott Street, Holderness Road, Hull HU8 8LR	Young People's Inst., George Street, Hull George Street, Hull. Start: 7.30 p.m.	September 30th; October 28th; November 25th; December 30th.
<b>LEEDS</b> Mrs. P. Johnson, Jones Knitting Centre, Holbeck Chambers, 101 The Headrow, Leeds 1.	Co-op. Restaurant, 10 Albion Street, Leeds 1. Start: 7.30 p.m.	September 15th; October 13th; November 17th.
<b>LEICESTER</b> Mrs. D. Mirams, 130 Harborough Road, Oadby, Leicester LE2 4LD.	Oadby Boys Club Hall, Wigston Road, Oadby, Leicester. Start: 7.30 p.m.	September 16th; October 21st; November 18th; December 16th.
<b>LOWESTOFT</b> Mrs. E. Shanahan, 18 The Avenue, Lowestoft, Suffolk.	18 The Avenue, Lowestoft. Start: 7.30 p.m.	September 2nd; October 7th; November 4th; December 2nd.
<b>NORTHAMPTON</b> Mrs. S. Rees, 18 Prince Street, Earls Barton, Northampton.	Y.M.C.A., Cheyne Walk, Northampton. Start: 7.30 p.m.	September 23rd; October 28th; November 25th.
<b>NORWICH</b> Mrs. Caston, 28 Winchester Tower, Norwich.	The Chantry Merrit Room, Norwich. Start: 7.30 p.m.	September 7th; October 5th; November 2nd; December 7th.
<b>PATRICROFT</b> Mrs. D. Box, 13 Green Lane, Patricroft, Manchester, M30 ORP.	13 Green Lane, Patricroft, Manchester, M30 ORP. Start: 7.30 p.m.	September 6th and every Monday from then on.
<b>ROMFORD</b> Mrs. D. Ellis, 28 Hall Road, Chadwell Heath, Essex.	Wykeham Hall, Market Place, Romford, Essex. Start: 7.30 p.m.	September 16th; October 21st; November 18th; December 16th.



# aran- style machine knitting

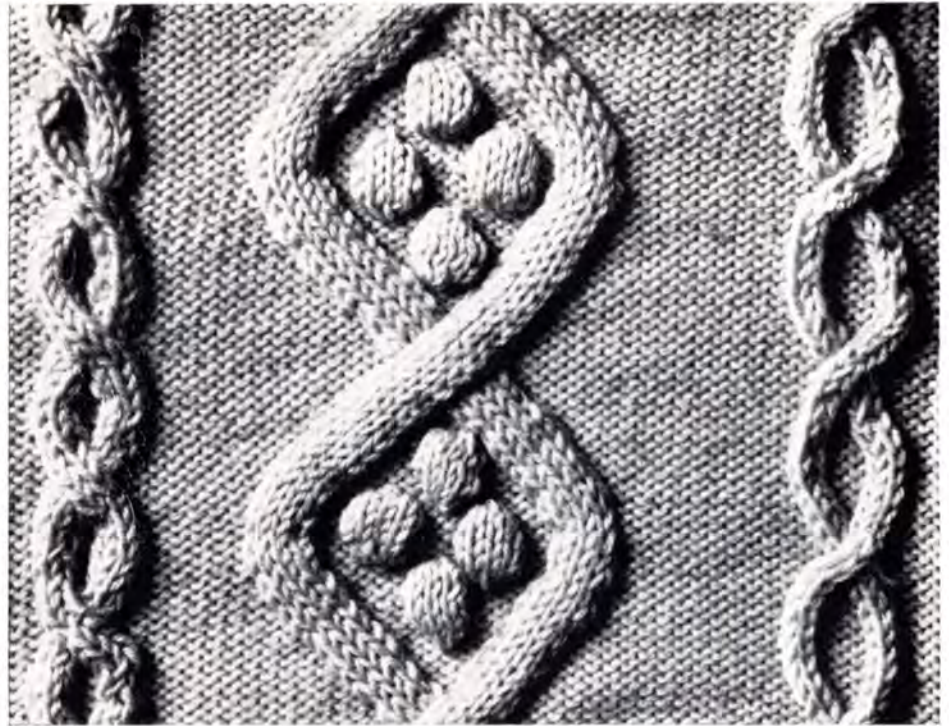

A really simple way to make the most complicated-looking styles; jerseys, dresses, cardigans, garments for all members of the family. Even a beginner can tackle this, and be delighted with the result.

Aran Knitting effects are achieved by using a simple stocking-stitch pattern and adding the design by appliqueing on knitted tubing and bobbles before sewing up the garment.

## Introduction

The aim of this article is to show how to transform plain, quickly knitted garments into Aran-styled or Cable trimmed garments. It contains ideas as well as instructions for the different trimmings created can be used in many different ways, on their own or combined one with another to give a completely individual touch to a cardigan or a dress, a pullover or coat, or indeed any knitted item.

There are designs included, but you will also find it easy to create others from the diagrams numbered 3 to 10.

The main points are as follows:

1. Any stocking-stitch pattern can be used.
2. The garment can be made using either the plain or purl side as the right side, according to the effect required.
3. Tubular knitting is used to make the patterns and this is made in varying widths to give different effects.
4. Bobbles are also used.
5. The tubular strips are applied on to the garment pieces to make the pattern, e.g. cables, diamond patterns, plaits etc.
6. More elaborate designs can be used by using an automatic pattern for the basic garment instead of stocking stitch.

**Instructions for the trimming** (4-ply wool is recommended for this type of work).

## Tubular Knitting.

Use the same wool and the same tension as for the main part of the garment to be trimmed. The width of the tube will depend on the number of stitches used. Cast on 3, 4, 5, or 6 needles. Depress right PART button. Pull down the fabric with the left hand and move the carriage with the right hand. Continue to the required length. (See Figure 1).



## Bobbles

Cast on 6 stitches by hand. \* Knit 6 rows. Lay a contrasting piece of waste wool across the needles and knit manually (i.e. operate the needles individually instead of moving the carriage across). Leave at least 9 inches of wool hanging before resuming. (This will be used for sewing up the bobble). Repeat from \* for each bobble required. (See Figure 2a).

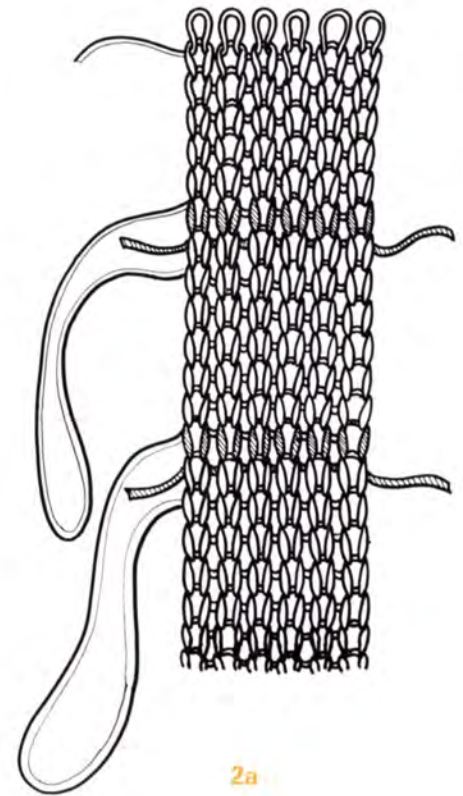



**To make up the bobbles.**

Cut strands of wool left for sewing up once, about 1½ ins. from edge, leaving a long end and a short end. Press strip of knitting with a damp cloth. This will prevent any unravelling. Pullout waste wool knitted in at every 7th row, thus separating the work into small sections. (See Figure 2b). Gather up each bobble by threading the long end of wool into a darning needle and thread through each stitch loop at top,

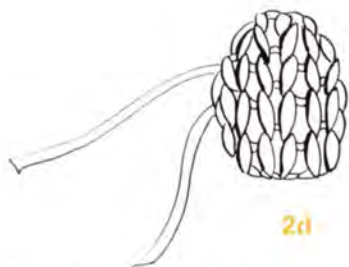
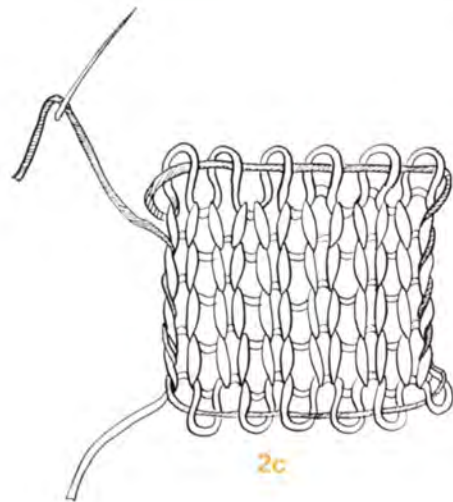
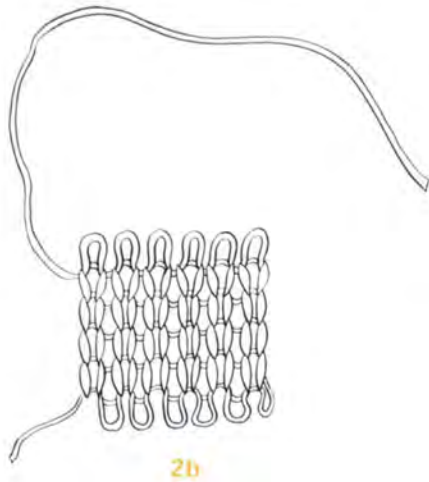

thread along side, then through each stitch loop at the bottom, and thread along the remaining side (Figure 2c). Draw up the thread and tie to the short end of wool left hanging. Do not cut off the ends as these can be used to sew the bobble on to the garment. (Figure 2d).

**How to use the trimmings**

**Figure 3.** Zig-Zag made with one length of tubing, with bobbles.

**Figure 4.** Diamond pattern made with two lengths of tubing, and bobbles.

**Figure 5.** Open cable made with two lengths of narrow tubing.

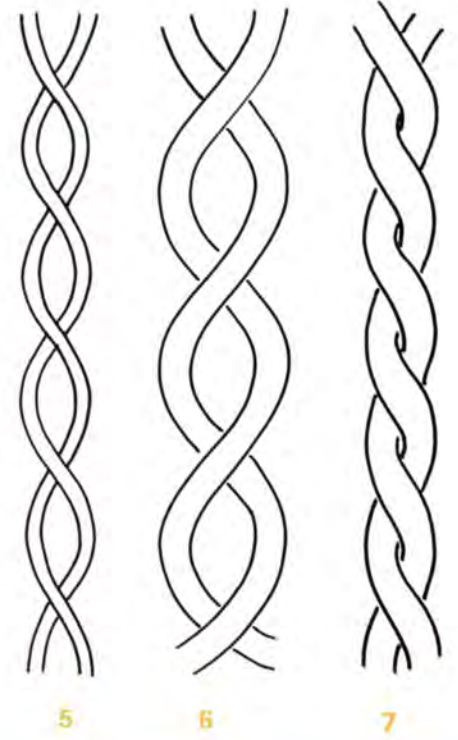
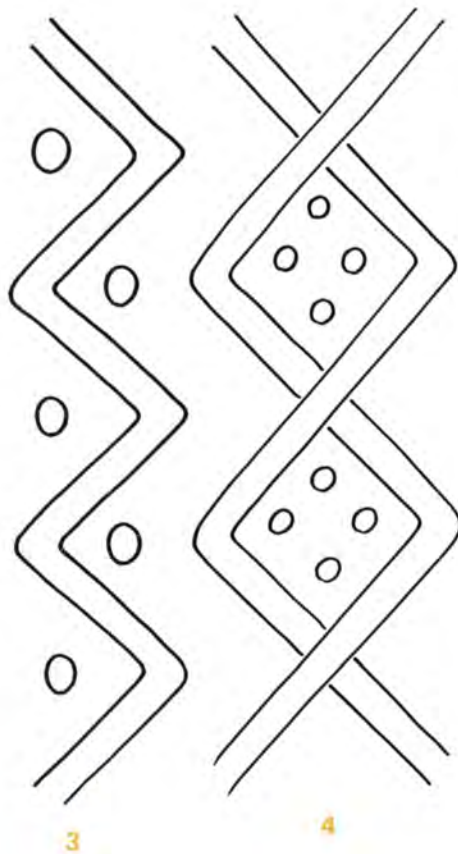

**Figure 6.** Open cable made with 2 strips of wider tubing.

**Figure 7.** Closed cable made with two lengths of wide tubing.

**Figure 8.** Open cable and bobbles.

**Figure 9.** Plait made with three lengths of tubing.

**Figure 10.** Alternate cable and diamond pattern with bobbles.

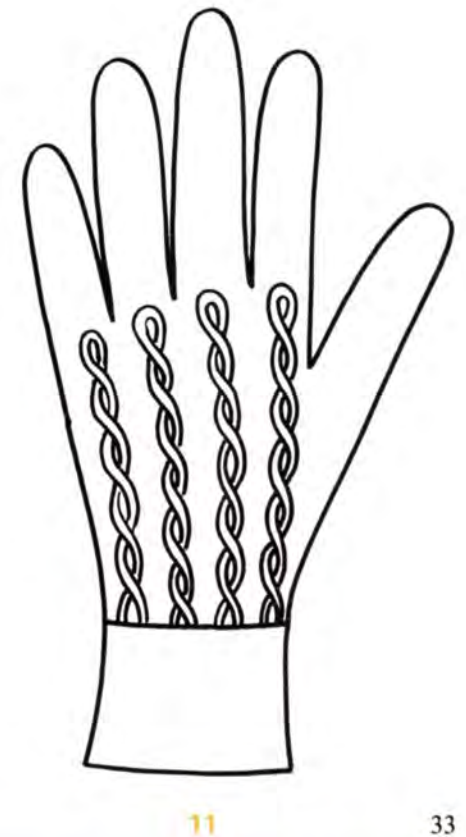
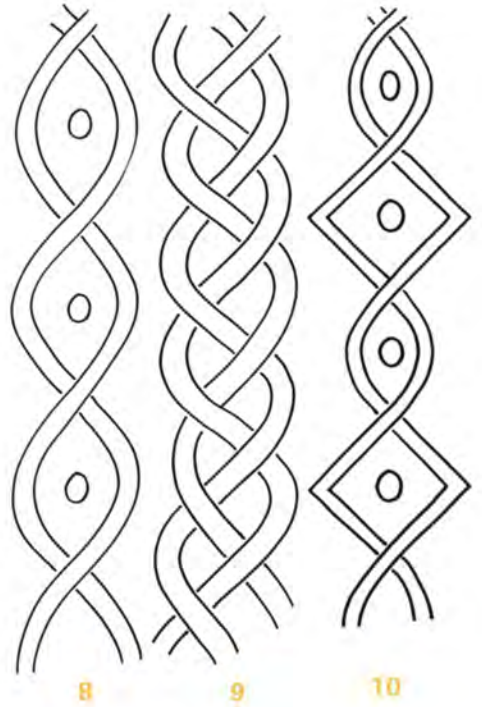





12

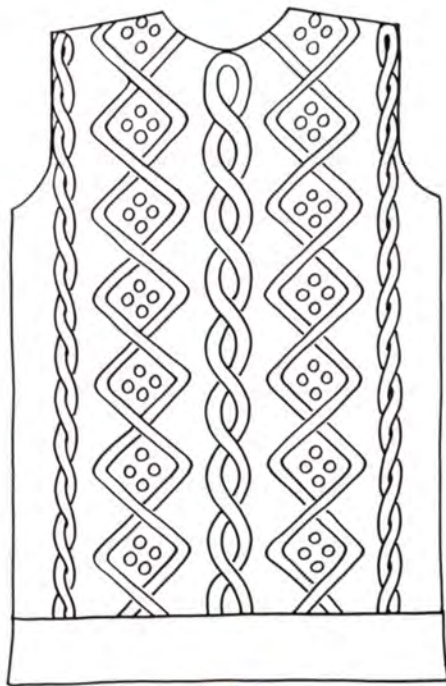

13



14

**Figure 11.** Cables are shown here as an attractive trimming for a plain glove.  
**Figure 12.** A coat or long cardigan can be effectively trimmed with cables.  
**Figure 13.** A plain dress lends itself to an Aran-style design.  
**Figure 14.** Sweaters can be trimmed lavishly with Aran-style patterning.  
**Figure 15.** Half-cables and bobbles; a panel of trimming suitable for a dress or jersey.  
**Figure 16.** Attractive basket-weave design would make an interesting fabric for skirt or sweater with bobbles optional.



15

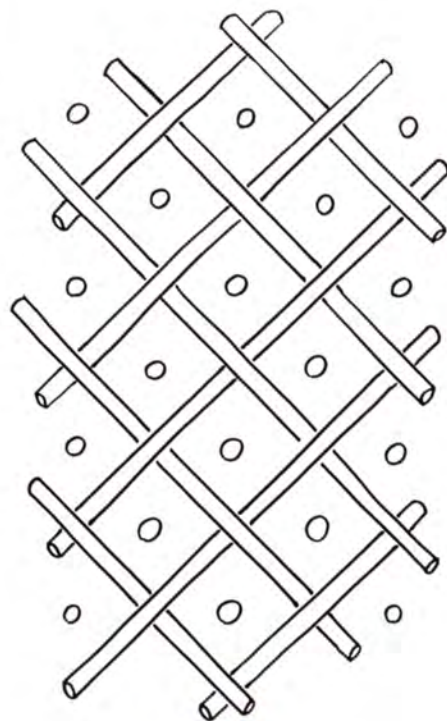

16



#### Instructions for a Garment

1. Choose a basic pattern for the garment and decide the type of trimming to be used. Remember when ordering the same wool for the appliquéd trimming. To estimate roughly the amount of tubing required, measure the length of the pattern panel. Multiply by three for each strip of cable or diamond, or by one-and-a-half for a zig-zag or half-cable strip.
2. Knit the basic garment but do not sew it up.
3. Knit the tubing to the required total length. (It can be cut into shorter pieces as required.)
4. Knit the required number of bobbles and sew them up. (See figures 2a, 2b, 2c and 2d).
5. Press the garment pieces and if the edges are inclined to curl, pin or tack them to a sheet of paper, or alternatively pin to an ironing board while arranging the tubing in place.



## a pretty face to end this issue . . . .

6. Mark out guide-lines for the pattern, on the garment with chalk or pins, using a tape measure to ensure correct spacing. (See figure A).
7. Mark with pins the points where the pieces of tubing will cross or change direction. Again use a tape measure for accurate spacing. (See figures A and B).
8. Pin the tubing in place taking care to cross over the pieces in the correct direction to create a balanced pattern. (Figure B).
9. Stitch the tubing *loosely* in place with matching wool or transparent thread. This can be done invisibly on the 'wrong side' of the work by just catching down the underside of the tubing with a running thread. (Take care that the sewing thread is not pulled tight as it is essential for the tubing to stretch naturally with the main knitted fabric.) Tuck in any ends of tubing and sew securely to avoid fraying.
10. Pin and then stitch the bobbles in place.
11. Repeat with the other sections of the garment.
12. When all the pieces have been trimmed, sew up in the usual way.

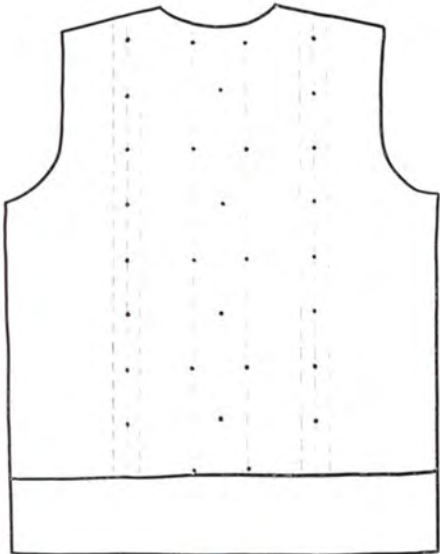

A.

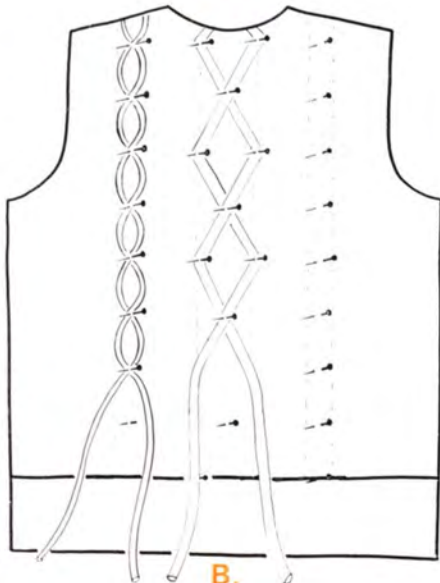

B.





Five pretty young ladies wearing five very pretty knitted dresses attended Miss Jane Weeks at her recent marriage. All the dresses were designed and knitted by Miss Weeks with the help of her Jones Knitleader and Jones Knitting Machine, and were knitted in a mixture of angora, nylon and wool. I think readers will agree that these outfits are really attractive and show just what can be done with . . . . you and your Jones.



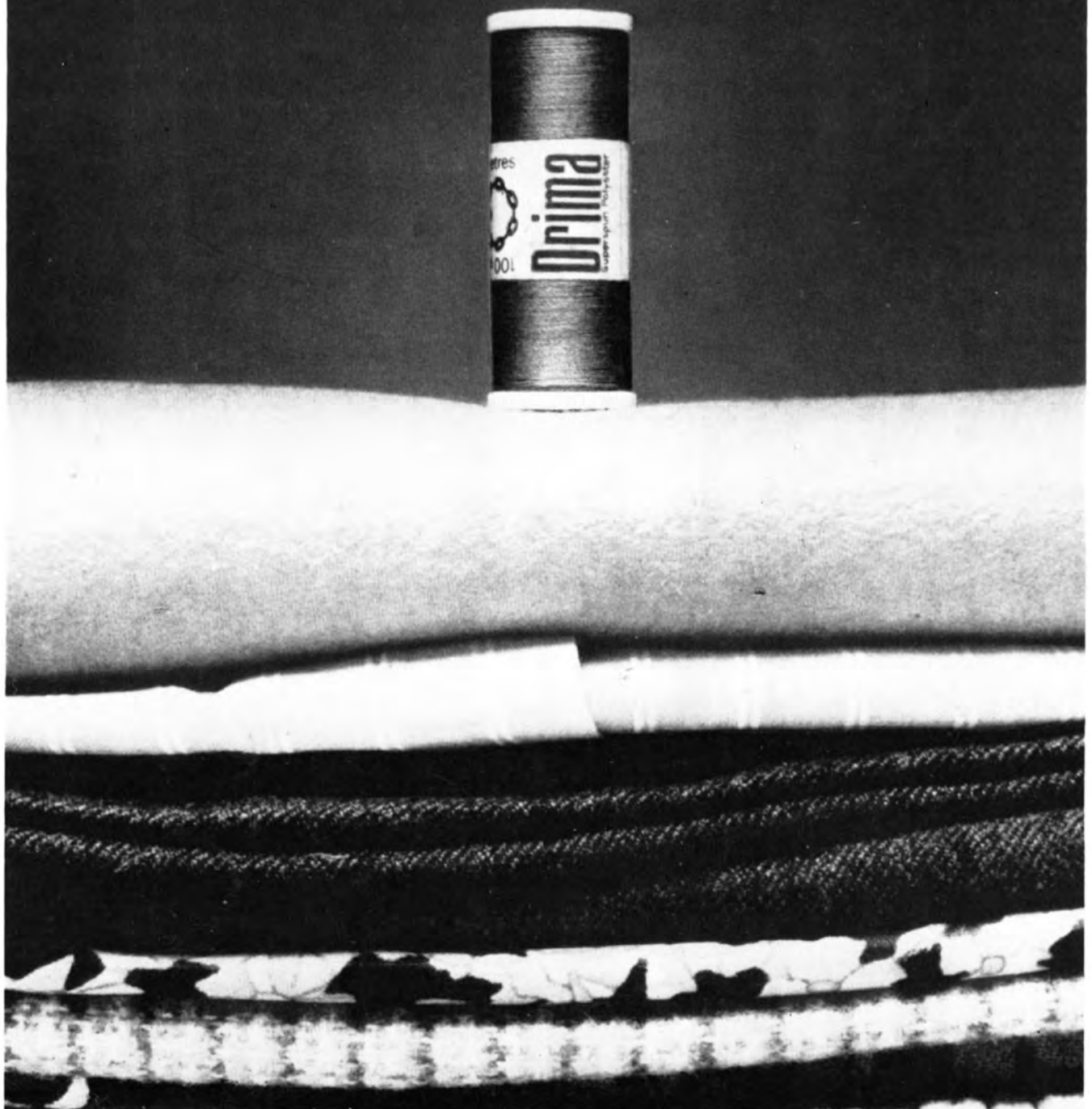

**The sociable sewing thread.  
Works happily with any fabric.**



 **Coats Drima** multi-purpose sewing thread—sews any material: heavy or light, natural or synthetic—by hand or machine. 100 yds on the compact spool.