

Jones / brother

# Stitchin' time

Vol 3 No's 4&5

50p





# contents

# Broadly Speaking

His 'n' Hers cardigans	3-4
Mans chunky sweater	5
Mens socks	6
Classic cardigan	7
Mans ribbed vest	8
Girls lacy dress	9-10
Two skirts	11-12
Toys for the kids	13-16
Knickerbockers	17
Hot pants - socks	18
Bedjacket	19
Father and Sons lumber jackets	20-22
Unisex poncho	23
Jones Clubs	24-25
Mans sleeveless pullover	26-27
Playsuit	28
Girls flared skirt	29
Mans jacket	30
Sew Easy! Lesson 5	31-38
Teenagers shortie sweater	39
Babys dress, coat and bootees	40-41
Toddlers cardigan	42
Pram coat with hood and leggings	43
Girls pinafore dress	44-45
Baby boy's suit	45-46
Christening dress	47
Rompers with short sleeves	48-49
Toddlers cross-over cardigan	50
Babys vest and pilch	51
Skirt and shortie jumper	52-53
Childs Fair Isle sweater	53-54
You write	55
Accessories	56
Boys ribbed sweater	57
Knitted doll	58-59
Sewing machine attachments	60-61
Mans lumber jacket	62
Ladies ribbed suit	63-64
Girls dress with pleated skirt	65
Childs sweater and hat	66-67

This edition of *Stitchin' time* is a bumper, two-in-one issue and contains a wealth of patterns and ideas for you to make - and give.

We have paid particular attention to styles and shapes that will appeal to every age group, and with Christmas coming we felt that in addition to fashion wear, our readers would welcome ideas for toys and gifts. We have therefore included a delightful variety of soft toys, pyjama cases and knitted articles for you to make. You will also find instructions for a fully-dressed knitted doll, every detail of which - with the exception of the facial features - has been made on the 588 machine.

Returning to the fashion scene, we are featuring two His 'n' Hers outfits in this issue, both of which would make very acceptable gifts. The His 'n' Hers fringed poncho is dramatic but wearable and is reproduced in *Stitchin' time* by kind permission of 'Modern Mother'. We also include two beautifully designed His'n' Hers cardigans, given a distinctly Swiss flavour by the Fair Isle pattern worked on a white background.

You will see that there are plenty of designs which will appeal to the in-between age groups, who are not always easy to cater for. The lacy pinafore dress is intended as a versatile girl's garment; pretty enough for parties and useful enough for casual, warmer wear. There's plenty to interest the boys, too; not least with the zip-fronted lumber-jackets which can be knitted alike for father and son.

Following the very successful Baby Section in the last issue, we are continuing with more designs for the smaller members of the family - giving good basic patterns for indoor and outdoor wear. A very lovely Christening gown is also included with this feature.

We know from our readers' letters that classic designs, particularly in ladies' wear, are always welcome and we have selected a number of suits, skirts and cardigans which will add variety to any winter wardrobe.

Veering towards the young trend styles, we are featuring some very eye-catching designs including a playsuit and a pair of knickerbockers. The knickerbockers look good with long boots and make a fashionable change from trousers.

The Sew Easy Course progresses to the Fifth Lesson and gives a variety of information on finishings. These range from buttonholes and jetted pockets, to bias strips for rouleau trimming - adding up to a wealth of hints for the keen dressmaker.

The Jones Club Page brings round-the-country news of Club activities and reports not only on the larger meetings, but on a smaller, successful Club which meets once a fortnight in Sussex. We think many of our readers may be interested to read of this house Club, since the story shows how enthusiasm and willingness to work together can produce friendly and enjoyable meetings within the home.

Finally, this two-in-one issue brings the total to five for the year. We think it contains enough ideas and patterns to keep our readers busy well into the New Year, when the next issue will be published. Until that time, we extend our best wishes for the coming Season and wish all our Members a very enjoyable Christmas.

N.B. CHARTS SUBMITTED BY DESIGNERS VARY DEPENDING ON WHICH MACHINE THE DESIGNER HAS USED. MOST PATTERNS USING EIGHT BUTTONS CAN BE DONE ON EITHER THE 588 OR THE 585.

THE DIFFERENCES ARE

588		585
REVERSE LEVER +		REVERSE DIAL A
REVERSE LEVER -		REVERSE DIAL B

The front cover design is not printed in pattern form as in the past we have been told designs like this were too 'trendy'. If however we receive sufficient requests for the pattern we will ask the designers to write it out in full.

## SUBSCRIPTION RATES FOR U.S.A.

### AND CANADIAN MEMBERS

CANADA \$8.00

U.S.A. \$7.50

(These rates include postage)



# his 'n' hers cardigan



## Materials

Listers Lavenda 4-ply.

11 (12, 13, 14, 15, 16, 17) ozs. in main colour. M.

3 (3, 3, 4, 4, 4, 5) ozs. in contrast. A.

2 (2, 3, 3, 3, 4, 4) ozs. in contrast. B.

1 (1, 1, 2, 2, 2, 2) ozs. in contrast. C.

V-neck Cardigan 5 buttons.

Round neck Cardigan 7 buttons.

## Measurements

To fit bust or chest sizes 34 (36, 38, 40, 42, 44, 46) ins.

Finished measurements 36 (38, 40, 42, 44, 46, 48) ins.

Length from top of shoulder 23½ (23½, 24½, 24½, 25½, 25½, 26½) ins.

Sleeve seam 17½ (17½, 18, 18, 18½, 18½, 18½) ins.

## Tension

15 sts. and 20 rows to 2 ins. over Fair Isle after pressing.

## Abbreviations

Sts., stitches; inc., increase; dec., decrease; foll., following; alt., alternate; beg., beginning; T., tension; 000, return row counter to 000.

## Notes

Figures in brackets refer to larger sizes respectively.

**581 and 585 machines.** For every row of Fair Isle knitted, 2 rows will show on Row Counter.

## ROUND NECK CARDIGAN

### BACK

**Ribbers:** Using M. cast on 135 (143, 151, 157, 165, 173, 179) sts. for 1 x 1 rib. with extra st. on right side. T4/4. Knit 20 rows. Transfer sts. to main bed for Fair Isle.

**Single machines:** Using M. cast on 135 (143, 151, 157, 165, 173, 179) sts. T6. Knit 39 rows. Make a hem and knit the row.

**All machines:** 000. T7. S.D. on 1. Knit 2 rows following Fair Isle chart knit until 120 (120, 126, 126, 130, 130, 136) rows have been worked. This will give a length of 14 (14, 14½, 14½, 15, 15, 15½) ins from base of rib (or hem).

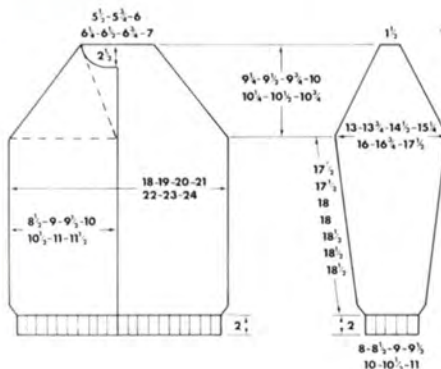

### Shape Raglan Armholes

000. Cast off 1 (2, 3, 4, 5, 6, 7) sts. at beg. of next 2 rows. Dec. 1 st. at both ends of next and every foll. alt. rows until 47 (47, 53, 55, 61, 63, 65) sts. remain then on every row until 41 (43, 45, 47, 49, 51, 53) sts. remain. Knit 1 row, slip sts. on to a knitting needle. Cast off sts. For V-neck Cardigan.

### RIGHT FRONT

**Ribbers:** Using M. cast on 64 (68, 72, 75, 79, 83, 86) sts. (with extra st. on right side on sizes 4, 5 and 6) for 1 x 1 rib. T4/4. Knit 20 rows. Transfer sts. to main bed for Fair Isle.

**Single machines:** Using M. cast on 64 (68, 72, 75, 79, 83, 86) sts. (with extra st. on right side on sizes 4, 5 and 6) T6. Knit 39

rows. Make a hem and knit the row.

**All machines:** 000. T7. Knit 2 rows. S.D. on 5 (3, 1, 8, 6, 4, 2). Following Fair Isle chart knit until 120 (120, 126, 126, 130, 130, 136) rows have been worked. Knit 1 row extra for Left Front. \*

### Shape Raglan Armholes

000. Cast off 1 (2, 3, 4, 5, 6, 7) sts. at beg. of next row. Knit 1 row. Dec. 1 st. at beg. of next and every foll. alt. row until 31 (32, 34, 35, 37, 38, 39) sts. remain. Carriage is at left.

### Shape neck

Cast off 5 (6, 7, 8, 9, 10, 11) sts. at beg. of next row. Continue raglan shaping as before *at the same time* knit 1 row. Dec. 1







# round and V neck chunky sweater

## Materials

**Round and V-neck Sweater:** 11 (12, 12, 13, 13, 13) balls (1 $\frac{3}{4}$  oz. approx.) Pingouin Classique Crylor yarn. (Knits as Double Knitting wool).

## Measurements

To fit chest sizes 42 (44, 46, 48, 50, 52) ins. Finished measurements 45 (47, 49, 51, 53, 55) ins. Length at centre back 26 (26 $\frac{1}{2}$ , 27, 27 $\frac{1}{2}$ , 28, 28 $\frac{1}{2}$ ) ins. Sleeve seam 18 $\frac{1}{2}$  ins. all sizes.

## Tension

12 sts. and 29 rows to 2 ins. over full Fisherman's Rib.

## Abbreviations

Sts., stitches; rep., repeat; inc., increase; dec., decrease; alt., alternate; beg., beginning; M.B., main bed; H.C.L.'s., holding cam levers; T., tension; 000, set row counter at 000.

## Notes

Figures in brackets refer to the larger sizes respectively. Fully fashioning at raglan is worked by transferring the 3rd st. onto 4th needle on each bed at both ends and moving the 2 end sts. 1 needle in. (2 sts. decreased at each end.) Fully fashioning at neck edge is worked by transferring the 2nd st. onto 3rd needle on each bed and moving end st. 1 needle in.

When last st. is on F.R. make sure the stitch is knitted when beginning the row.

## V-NECK SWEATER - Back

Cast on 137 (141, 149, 153, 161, 165) sts. for 1 x 1 rib. Knit 2 circular rows. T.4/4. Knit 20 rows. Set M.B. and Ribber for full Fisherman Rib. 000. T.5/5. Knit 188 rows. This will give a length of 15 ins. from cast-on edge. Adjust length here if required. Mark ends with coloured wool.\*\*

## Shape Raglan armholes

000. Dec. 2 sts. (see Notes) at both ends of next and every following 8th row 8 (9, 9, 10, 10, 11) times in all and then every following 6th row until 37 (37, 41, 41, 45, 45) sts. remain. Knit 1 row. Change to plain 1 x 1 rib. T.4/4. Knit 20 rows. Knit 1 loose row. Transfer sts. to M.B. and cast off using chain method.



## Front

Work as given for Back to \*\*.

## Shape Raglan armholes and divide for neck

000. Dec. 2 sts. at both ends of next and following 8th row. Knit 1 row. Transfer centre st. onto adjacent needle. Push needles furthest from Carriage to E position. (If preferred slip sts. onto a knitting needle.) Knit on remaining sts. first. H.C.L.'s III. Knit 6 rows. Dec. 2 sts. at raglan edge on next row. Knit 3 (5, 1, 3, 5, 1) rows. Dec. 2 sts. (see Notes) at neck edge on next and every following 16th row, at the same time knit 4 (2, 6, 4, 2, 6) rows. Dec. 2 sts. at raglan edge on next and every following 8th row 5 (6, 6, 7, 7, 8) times in all and then every following 6th row until 8 (10, 8, 10, 6, 10) sts. remain. Continue raglan decs. only until 6 sts. remain. Knit 5 rows. Dec. 2 sts. at neck edge on next row (not fully fashioning.) Rep. last 6 rows once

more. Cast off. Return sts. to B. position by hand. Knit to match first side reversing all shapings.

## Sleeves

Cast on 57 (61, 65, 69, 73, 77) sts. for 1 x 1 rib. Knit 2 circular rows. T.4/4. Knit 24 rows. Set M.B. and Ribber for full Fisherman's Rib. 000. T.5/5. Knit 10 rows. Inc. 2 sts. at beg. of next 2 rows and every following 19th and 20th row until there are 97 (101, 105, 109, 113, 117) sts. Knit straight until 232 rows have been worked. This will give a sleeve seam of 18 $\frac{1}{2}$  ins. Adjust here if required. Mark ends with coloured wool.\*

## Shape Raglan top

000. Dec. 2 sts. (see Notes) at both ends of next and every following 8th row until 29 (29, 33, 33, 37, 37) sts. remain and then every following 6th row until 13 sts. remain. Knit 5 rows. Transfer 2nd st. onto



3rd needle on ribber and 3rd st. onto 4th needle on M.B. at each end. 9 sts. remain. Knit 1 row. Slip sts. onto a knitting needle.

#### Neckband

With wrong side facing pick up and place on M.B. 80 (84, 88, 92, 96, 100) sts. from 1 front neck. Using odd length of yarn. Knit 1 row. Place 9 sts. of 1 sleeve at raglan edge of front. Keeping rib correct transfer alt. sts. to Ribber. T.4/4. Knit 10 rows, decreasing 2 sts. at neck edge on every alt. row as V-neck decs. then knit 10 rows inc. 2 sts. on every alt. row. Knit 1 row. Cast off as Back. Pick up sts. from other side of neck and sleeve and knit to match first side.

#### To make up

Pin out and press with a cool iron over a dry cloth. Join side, sleeve and raglan seams. Join mitred front seam of neckband, turn to wrong side and slip-stitch in place. Press seam.

#### ROUND NECK SWEATER - Back

Knit as given for Back of V-neck Sweater.

#### Front

Knit as given for Back to \*\*.

#### Shape Raglan armholes

000. Dec. 2 sts. at both ends of next and every following 8th row 8 (9, 9, 10, 10, 11) times in all and then every following 6th row until 61 (61, 65, 65, 69, 69) sts. remain. Knit 3 rows. Using odd length of yarn cast off 23 (23, 27, 27, 31) sts. at centre. Push needles furthest from Carriage to E position. (If preferred slip sts. onto a knitting needle). Knit on remaining sts. first. H.C.L.'s III. Knit 2 rows. Dec. at raglan edge on next and following 6th row only, at the same time dec. 2 sts. at neck edge (not fully fashioning) on next and alt rows 5 times in all. Knit 1 row. Dec. 1 st. at neck edge only on next and every alt. row until 2 sts. remain. Knit 1 row. Cast off. Return sts. at left to B position by hand. Knit to match first side reversing all shapings.

#### First sleeve

Knit as given for Sleeves of V-neck Sweater to \*. (Knit 1 row extra for second sleeve).

#### Shape Raglan top

Dec. 2 sts. at both ends of next and every following 8th row until 25 sts. remain. Knit 7 (7, 5, 5, 3, 3) rows. Carriage is at right. Dec. 2 sts. at left side and cast off 6 sts. at right side on next row. Knit 1 row. Dec. 2 sts. at right side only on next and every alt. row until 3 sts. remain. Cast off.

#### Second sleeve

Knit as given for first sleeve, reversing shapings at raglan top.

#### Neckband

Join front raglan seams (shorter edge of sleeve raglan goes to front). With wrong side facing pick up and place on M.B. 23 sts. from top of first sleeve 15 sts. down front slope 23 (23, 27, 27, 31, 31) sts. across centre front, 15 sts. up other side and 23 sts. from second sleeve, 99 (99, 103, 103, 107, 107) sts.

Using odd length of yarn knit 1 row. Keeping rib correct, transfer every alt. st. to ribber. T.4/4. Knit 20 rows. Knit 1 loose row. Cast off as for Back.

#### To make up

Pin out and press with a warm iron over a dry cloth. Join side, sleeve and back raglan seams. Turn neckband to wrong side and slip-stitch in place. Press seams.



## mens socks IN TWO LENGTHS

#### Materials

3 (3, 4, 4) ozs. Patons Nylox 4-ply wool for short socks, 4 (4, 4, 5) ozs. for long socks, 2 knitting needles with points at both ends.

#### Measurements

Length of foot 9 (9½, 10, 10½) ins.  
Length of leg to ankle (short) 9 ins. (long) 12 ins.

#### Tension

16 sts. and 18 rows to 2 ins. over st.st.

#### Abbreviations

sts., stitches; HCL's, holding cam levers; T., tension; 000, set row counter at 000.

#### Notes

**Important.** For every circular row knitted 2 rows will show on row counter.

#### Shaping Heel

As you are now knitting on ribber needles only there will be more work hanging down on ribber needles while main bed work is stationary. To make work easier either hang side weights, or pull by hand, the knitting on ribber while heel is being turned.

#### To knit

Cast on 64 sts. as 1 x 1 rib. T.4/4. Knit 22 rows. Pull undone 16 sts. nearest to carriage. Transfer all ribber sts. to main bed. Remove casting on comb and weights. Push centre 32 needles on ribber to B position. Slip 16 sts. at each end of work onto 2 knitting needles, turn the 2 outer edges (A) in towards centre (B) and replace

sts. onto ribber needles.

main bed	A	32		A
	16	16	16	16

ribber B

32 sts. on main bed and 32 sts. on ribber. Replace comb through ribbing and set machine for circular knitting. Half pitch knob on H. 000. T.7/7. Knit 58 circular rows for short socks and 84 circular rows for long socks (or desired length).

#### Shape Heel

Push both part buttons. Knit on ribber sts. only. Set ribber carriage for st.st. (both knobs on N. See notes before starting heel).

Always winding wool round first needle in E position push 1 needle at opposite end to carriage to E position on next 16 rows and back to D position on next 16 rows. Reset carriage for circular knitting. 000. Knit 54 (60, 64, 70, 74) circular rows (or desired length less 1½ ins.).

#### Shape Toe

Dec. 1 st. on each bed at each end by transferring the 2nd stitch onto the 3rd needle and moving the end stitch 1 needle in. Knit 2 circular rows. Continue dec. on next and every following alt. circular row until 20 sts. remain on each bed, then every circular row until 8 sts. remain on each bed. Slip onto 2 knitting needles and graft.

#### To Make Up

Join rib seams. Press with a hot iron over a damp cloth.



# classic cardigan

## WITH LACY RAGLAN SHAPING

### Materials

16 (17, 18, 19, 20)  $\frac{1}{4}$  oz. balls Listers Bel Air Courtelle Double Knitting, 5 buttons for V-neck Cardigan, 7 buttons for Round-neck Cardigan.

### Measurements

To fit bust sizes 40 (42, 44, 46, 48) ins. Actual measurements 42 (44, 46, 48, 50) ins. Length at back neck 22 $\frac{1}{2}$  (22 $\frac{3}{4}$ , 23, 23 $\frac{1}{4}$ , 23 $\frac{1}{2}$ ) ins. Sleeve seam 17 ins.

### Tension

12 sts. and 18 rows to 2 ins.

### Abbreviations

Sts., stitches; inc., increase; dec., decrease; alt., alternate; beg., beginning; T., tension; 000, set row counter at 000.

### Notes

Fully fashioning at raglan is worked by transferring 4th st. onto 5th needle and moving 3 end sts. 1 needle in. Fully fashioning at neck edge for V-neck Cardigan is worked by transferring 2nd st. onto 3rd needle and moving the end st. 1 needle in.

### Lacy Stitch

Counting from edge transfer 3rd st. onto 4th needle. Leave empty need in B position. Knit 2 rows. Counting from edge transfer 3rd st. onto 2nd needle. Leave empty needle in B position. *Important:* work fully fashioning before the lace stitch.

### V-NECK CARDIGAN

#### BACK

**Ribbers.** Cast on 127 (133, 139, 145, 151) sts. for 1×1 rib. T6/6. Knit 12 rows. Transfer sts. to main bed.

**Mock rib.** Using contrasting yarn. Cast on 64 (67, 70, 73, 76) sts. on alt. needles. Knit a few rows. Change to main yarn. T6. Knit 23 rows. Make a hem and knit the row.

**All machines.** Inc. 1 st. at right side. 128 (134, 140, 146, 152) sts. 000. T10. Knit straight until 102 rows have been worked. This will give a length of 13 ins. from beginning. Adjust length here if required.

#### Shape raglan armholes

000. Cast off 3 (4, 4, 5, 5) sts. at beg. of next 2 rows. Dec. 1 st. and work lace st. (see notes) at each end of next and every following alt. row until 40 (42, 48, 50, 56) sts. remain then every row until 36 (38, 40, 42, 44) sts. remain. Cast off. Slip sts. on to a knitting needle for Round Neck Cardigan.

#### RIGHT FRONT

**Ribbers.** Cast on 61 (65, 67, 71, 73) sts. for 1×1 rib. T6/6. Knit 12 rows. Transfer sts. to main bed.

**Mock rib.** Using contrasting yarn cast on 31 (33, 34, 36, 37) sts. on alt. needles. Knit a few rows. Change to main yarn. T6. Knit 23 rows. Make a hem and knit the row.



**All machines.** Inc. 1 st. at right side on sizes 1, 3 and 5. 62 (65, 68, 71, 74) sts. 000. T10. Knit straight until 102 rows have been worked. Knit 1 row extra for Left Front.

#### Shape raglan armhole and neck

000. Cast off 3 (4, 4, 5, 5) sts. at beg. of next row. Knit 1 row. Dec. 1 st. at raglan edge on next and every following alt. row, *at the same time* dec. 1 st. at neck edge (see Notes) on next and every following 4th row 3 (5, 7, 9, 11) times in all then every following 6th row until 7 (7, 8, 8, 9) sts. remain. Continue raglan shaping only until 4 (4, 6, 6, 8) sts. remain, then on every row until 2 sts. remain. Cast off.

#### LEFT FRONT

Knit as Right Front reversing all shapings.

#### SLEEVES

**Ribbers.** Cast on 53 (57, 61, 65, 69) sts. for 1×1 rib. T6/6. Knit 16 rows. Transfer sts. to main bed.

**Mock rib.** Using contrasting yarn cast on 27 (29, 31, 33, 35) sts. on alt. needles. Knit a few rows. Change to main yarn. T6. Knit 3 rows. Make a hem and knit the row.

**All machines.** Inc. 1 st. at right side. 54 (58, 62, 66, 70) sts. 000. T10. Knit 12 rows. Inc. 1 st. at each side of next and every following 6th row until there are 90 (94, 98, 102, 106) sts. Knit straight until 132 rows have been worked. This will give a sleeve seam of 17 ins. Adjust length here if required.

#### Shape raglan top

Cast off 3 (4, 4, 5, 5) sts. at beg. of next 2 rows. Knit 2 rows. Dec. 1 st. (see Notes) at each end of next and every following 4th row 5 (5, 4, 4, 3) times in all then every alt. row until 10 sts. remain. Cast off. Slip sts. onto a knitting needle for Round Neck Cardigan.

#### FRONT BAND

Mark position on Right Front, for 5 buttonholes, the first  $\frac{1}{2}$  inch above lower edge and the final one at beg. of neck shaping. Space remainder evenly between.

**Ribbers.** Cast on 11 sts. for 1×1 rib. T6/6. Knit straight making buttonholes to match markers over 3 centre sts. Continue straight until long enough to fit up both fronts across sleeve tops and across back neck, stretching to fit. Cast off.

**Single machines.** Cast on 15 sts. by hand. T9. Knit straight making buttonholes to



match markers over needles 4 and 5 from each end. Continue straight until long enough to fit up both fronts, across sleeve top and across back neck, stretching to fit. Cast off.

#### To make up

Pin out and press with a warm iron over a dry cloth. Join side, sleeve and raglan seams. Sew ribbed front band in position, neaten buttonholes and sew on buttons. Sew st. st. front band in position, turn to wrong side and slip stitch in place. Neaten buttonholes and sew on buttons. Press seams.

### ROUND NECK CARDIGAN BACK AND SLEEVES

Knit as given for V-neck Cardigan.

#### RIGHT FRONT

Knit as Right Front of V-neck Cardigan to \*.

#### Shape raglan armhole

000. Cast off 3 (4, 4, 5, 5) sts. at beg. of next row. Knit 1 row. Dec. 1 st. at beg. of next and every following alt. row until 29 (30, 33, 34, 37) sts. remain. Carriage is at left.

#### Shape neck

Cast off 6 (7, 8, 9, 10) sts. at beg. of next row. Continuing raglan decreasing as before, knit 2 rows. Dec 1 st. at neck edge on next and every following alt. row until 6 (6, 8, 8, 10) sts. remain. Continue raglan decreasing only until 4 (4, 6, 6, 8) sts remain, then on every row until 2 sts. remain. Cast off.

#### NECKBAND

With wrong side facing pick up and place on machine 21 (22, 23, 24, 25) sts. up front neck, 10 sts. from one sleeve, 35 (37, 39, 41, 43) sts. from back neck, 10 sts. from other sleeve and 21 (22, 23, 24, 25) sts. down front neck, 97 (101, 105, 109, 113) sts. Knit 1 row. Transfer alt. sts. to ribber for 1x1 rib. T6/6. Knit 8 rows. Knit 1 loose row. Transfer sts. to main bed. Cast off using chain method.

#### Mock rib

Pick up sts. as ribber. Knit 1 row. Transfer every alt. st. onto adjacent needles. T5. Knit 16 rows. Knit 1 loose row. Cast off making a chain over empty needles.

#### BUTTON BAND

**Ribbers.** Cast on 11 sts. for 1x1 rib. T6/6. Knit straight until long enough to fit up front, stretching to fit.

**Single machines.** Cast on 15 sts. by hand. T9. Knit as ribbers.

#### BUTTONHOLE BAND

Mark positions on Right Front for 7 buttonholes the first  $\frac{1}{2}$  inch from lower edge and the final one  $\frac{1}{2}$  inch from the end. Space remainder evenly between.

**Ribbers.** Cast on 11 sts. for 1x1 rib. T6/6. Knit as buttonband making buttonholes to match markers over 3 centre sts. Cast off.

**Single machines.** Cast on 15 sts. by hand. T9. Knit as buttonband making buttonholes to match markers over needles 4 and 5 from each end. Cast off.

#### To make up

Pin out and press with a warm iron over a dry cloth. Join side, sleeve and raglan seams. Turn mock rib neckband to wrong side and slip stitch in place. Sew ribbed front bands in position, neaten buttonholes and sew on buttons. Sew st. st. front bands in position, turn to wrong side and slip stitch in place. Neaten buttonholes and sew on buttons. Press seams.



# ribbed vest

#### Materials

3 ozs. Brown, 3 ozs. Cherry, 1 oz. Orange, 4 ozs. Grey. Patons Purple Heather 4 ply. All sizes.

#### Measurements

To fit chest sizes 32 (34, 36, 38) ins.  
Length to shoulder: 21 $\frac{1}{4}$  (22, 22 $\frac{1}{4}$ , 22 $\frac{1}{2}$ ) ins.

#### Tension

16 sts and 30 rows to 2 ins. English rib. (1x1 rib). 18 sts. and 20 rows to 2 ins. 2x2 rib.

#### Abbreviations

B., Brown; C., Cherry; O., Orange; G., Grey; Sts., stitches; K., knit; dec., decrease; Rem., remaining; beg., beginning; COA, cast on automatically; HCL's, Holding cam levers; 000, Set row counter to 000; COL., Carriage on left.

#### Notes

Figures in brackets refer to larger sizes respectively.

#### BACK

\* Using B wool COA 110 (118, 126, 134) sts. for 2x2 rib. T5/4. 000. K. 60 rows. Set the machine for English rib and move the appropriate sts. to correct bed. 000. T5/3. Change to C wool, K. 30 rows. Change to

O wool, K. 4 rows. Change to G wool, K. 30 rows. Change to O wool, K. 4 rows. Change to C wool, K. 30 rows. Change to O wool, K. 4 rows. Change to G wool, K. until 120 rows have been worked.

#### Shape Armholes

000. Continuing in G wool only, cast off 16 (18, 20, 22) sts. at beg. of next 2 rows \*. K. 60 rows. COL.

#### Neck Shaping

\*\* With an odd length of wool, cast off by hand 38 (42, 46, 50) sts. at centre of work. Push 20 sts. at right of machine to E pos. HCL's III. Work on rem. 20 sts. at left of machine only. K. straight until 116 (120, 124, 128) rows have been worked. Cast off. HCL's I Push needles in E pos. back to C pos. Join wool at centre and K. as left side from \*\*.

#### FRONT

K. as Back from \* to \*. K. 10 rows. Then as Back from \*\* to \*\*.

#### TO MAKE UP

Join shoulder and side seams. Press seams.



# girls lacy dress and cardigan

## Materials

**Dress:** 6 (7, 7, 8) ozs. Listers Lavenda 3-ply, 5 (5, 6, 6) buttons.

**Cardigan:** 5 (6, 6, 7) ozs. Listers Lavenda 3-ply, 4 (4, 5, 5) buttons.

## Measurements

To fit bust sizes 24 (26, 28, 30) ins.

**Dress:** Finished measurements 25 (27, 29, 31) ins. Length to back neck 20 (22, 24, 26) ins. Sleeve seam 7 (7½, 8, 8½) ins.

**Cardigan:** Finished measurements 26 (28, 30, 32) ins. Length to back neck 14 (15, 16, 17) ins. Sleeve seam 11 (12½, 14, 15½) ins.

## Tension

Skirt pattern 14 sts. and 20 rows to 2 ins. after pressing. Yoke pattern 15 sts. and 23 rows to 2 ins. after pressing.

## Abbreviations

sts., stitches; inc., increase; dec., decrease; alt., alternate; foll., following; beg., beginning; T., tension; 000, set row counter at 000.

## Notes

Fully fashioning at raglan edges is worked by transferring the 4th st. onto the 5th needle and moving the 3 end sts. 1 needle in. The shaping at neck edge of cardigan is worked by transferring the 2nd st. onto the 3rd needle and moving the end st. 1 needle in. Keep the fully fashioning sts. in st.st.

## DRESS - BACK

**Skirt:** Cast on 102 (108, 116, 122) sts. by hand. T6. Knit 5 rows. Knit 1 loose row for hemline T6. Knit 6 rows. 000. T6. Following chart 1 knit 8 rows. Dec. 1 st. at each side on next and every foll. 16th (18th, 16th, 18th) row until 88 (94, 100, 106) sts. remain. Knit straight until 120 (136, 144, 160) rows have been worked. Slip sts. onto 2 knitting needles\*.

## Right Back Bodice

Counting from centre and working to the right, push 47 (50, 54, 57) needles to B position. \*\* With purl side facing replace right half of skirt 44 (47, 50, 53) sts. onto machine inc. 3 (3, 4, 4) sts. evenly along the row. 000. T6.

Following chart 2 knit 16 (16, 22, 22) rows. (Knit 1 row extra for Left Back Bodice). This will give a finished length to under-arm of 14 (15½, 17, 18½) ins. Adjust length here if required.

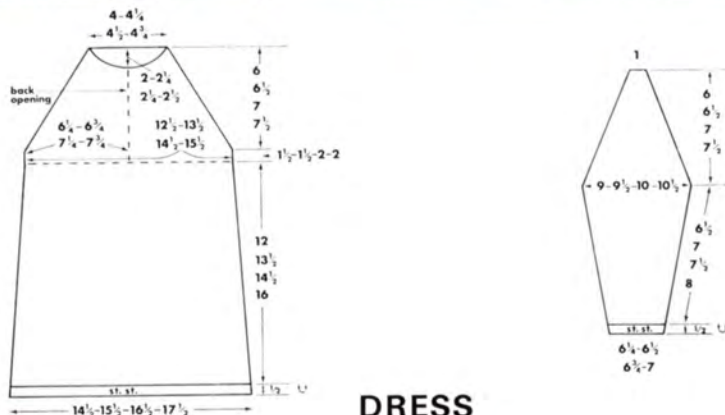







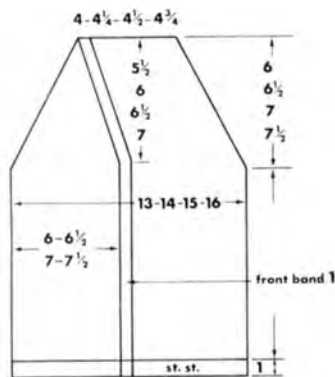
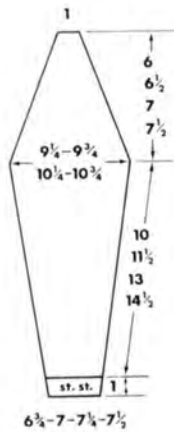

## CARDIGAN

## PHOTOGRAPHIC COMPETITION

We have been very disappointed with the response to our photographic and modelling competition announced in our spring issue. The initial flurry of entries has slowly trickled to a halt so that we now stand in the unusual position of having insufficient entries to enable us to give the promised 101 prizes!

In all fairness, we do feel that lack of response could be accounted for in two ways. Firstly, because of the delay in sending out the issue which initially contained the competition. Secondly, because the original closing date was August 31st and our readers may not have realised that this has been extended.

We refuse to accept that our readers can be quite so disinterested – and we gently bring to your attention that this competition is again extended: until the end of March. We will be happy to receive your entries until well into that month; after which time we will award our prizes – as planned.

## two skirts in two lengths

### Materials

**St.-st. skirt – Mini length:** 10 (11, 12, 13, 14) ozs. Listers Lavenda Double Knitting wool, allow an extra 4 ozs. for Knee-length Skirt,  $\frac{3}{4}$  inch wide elastic for waist. No. 10 knitting needles.

**Woven Skirt – Mini length:** 7 (8, 9, 10, 11) ozs. Listers Lavenda 3-ply wool. A (knitting) 4 (5, 5, 6, 6) ozs. Lavenda 4-ply wool; B (weaving). Allow an extra 2 ozs. of 3-ply and 1 oz. of 4-ply for Knee-length Skirt;  $\frac{3}{4}$  inch wide elastic for waist.

### Measurements

To fit hip sizes 36 (38, 40, 42, 44) ins.

Finishes measurements 37 (39, 41, 43, 45) ins.

Mini-length 16 inches.

Knee-length 25 inches.

### Tension

**St.-st. skirt:** 12½ sts. and 16 rows to 2 ins. after pressing.

**Woven skirt:** 13 sts. and 23 rows to 2 ins. after pressing.

### Abbreviations

K., knit; sts., stitches; dec., decrease; rep., repeat; foll., following; patt., pattern; adjust., adjust length at this stage if required; beg., beginning; M.B., main bed; T., tension; 000, set row counter at 000.

### Notes

Decreasing on st.-st. skirt is worked by transferring 3rd st. on to 4th needle and moving the end 2 sts. 1 needle in.

### STOCKING-STITCH SKIRT

#### Knee-length Back and Front alike

Using D.K. wool, cast on 144 (150, 156, 162, 168) sts. by hand. T9. Knit 8 rows. 000. T10. Knit 18 rows. \* Dec. 1 st. (see notes) at each end of next and every foll. 8th row until 116 (122, 128, 134, 140) sts. remain. \* Knit straight until 136 rows have been worked. This will give a finished length to hips of 17 ins. (Adjust). Mark ends with contrast wool.

#### \*\* Shape to Waist

000. Dec. 1 st. at each end of next and every foll. 4th row until 90 (96, 102, 108, 114) sts. remain. Knit 3 rows.

#### Waistband

**Ribbers:** Transfer alternate sts. to ribber for 1x1 rib. T7/7. Knit 8 rows. Cast off loosely in rib.

**Hand Knitters:** Using No. 10 needles knit 8 rows in k. 1, p. 1, rib. Cast off.

#### Mini-length

Using D.K. wool cast on 128 (134, 140, 146, 152) sts. by hand. T9. Knit 8 rows. 000. T10. Knit 6 rows. Knit as Knee-length skirt from \* to \*. Knit straight until 64 rows have been worked. This will give a finished length to hips of 8 ins. (Adjust). Knit as Knee-length skirt from \*\* to end.

#### TO MAKE UP

Pin out and press with a hot iron over a damp cloth. Join side seams. Cut elastic to fit waist, join ends and work a herringbone st. over it to inside of waistband. Turn hem at lower edge to wrong side end slip-stitch in place. Press seams.



### WOVEN SKIRT

#### Knee-length Back and Front alike

With 3-ply wool (A) cast on 150 (156, 162, 170, 176) sts. by hand. T5. Knit 12 rows. 000. T5. Foll. chart 1 knit 6 rows. Dec. 1 st at each end of next and every foll. 14th row, *at the same time* knit a further 6 rows of chart 1. Knit 2 rows in st.st. \* Work 34 rows of chart 2. Knit 2 rows in st.st. 000. Foll. chart 1 continue dec. until 122 (128, 134, 142, 148) sts. remain. \* Knit straight until 144 rows have been worked. This will give a finished length to hips of 17 ins. (Adjust). Mark ends with contrast wool.

#### \*\* Shape to waist

000. Dec. 1 st. at each end of next and every foll. 6th row until 96 (102, 108, 116, 124) sts. remain.









# draught excluder

Christmas gifts from odds and ends. The three articles illustrated were made from odd scraps of material cut to the shapes indicated in the diagrams. We have made the diagrams to scale but you will have to enlarge them on to tissue paper before cutting your material. We hope you enjoy trying these and that the finished result makes a presentable gift.

All these gifts were sent in by Miss Audrey Whitley of Gorleston-on-Sea, Gt. Yarmouth.

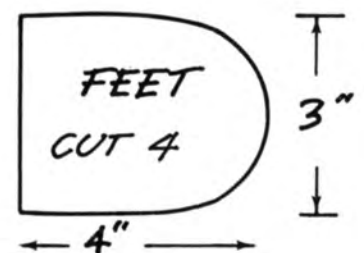
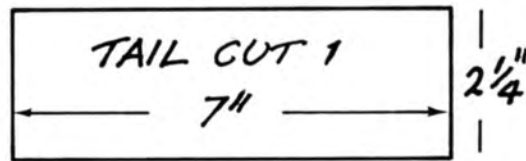
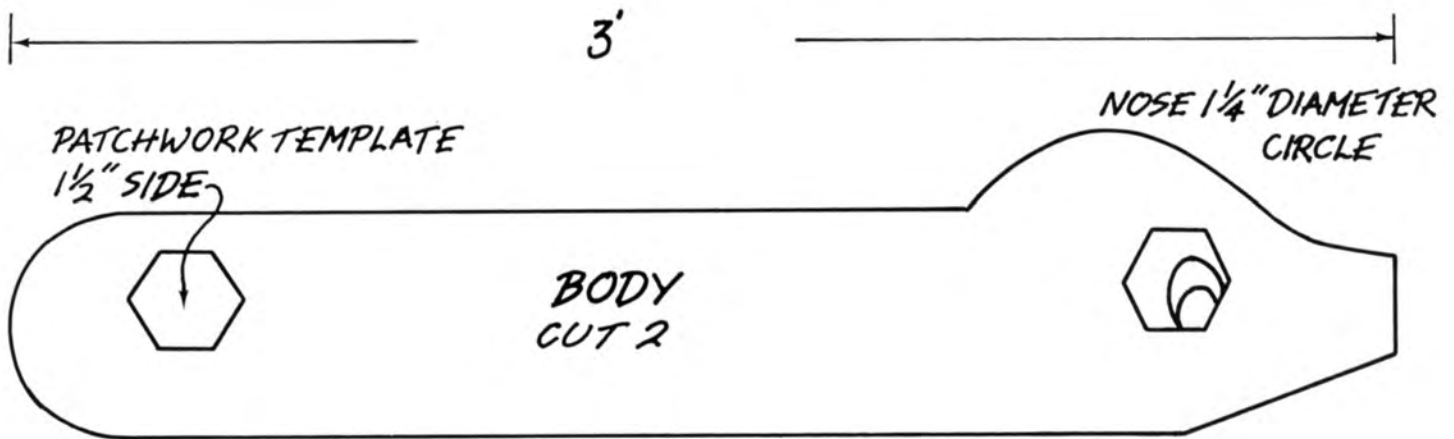





# Mr. Spotty

# tramp & scarecrow

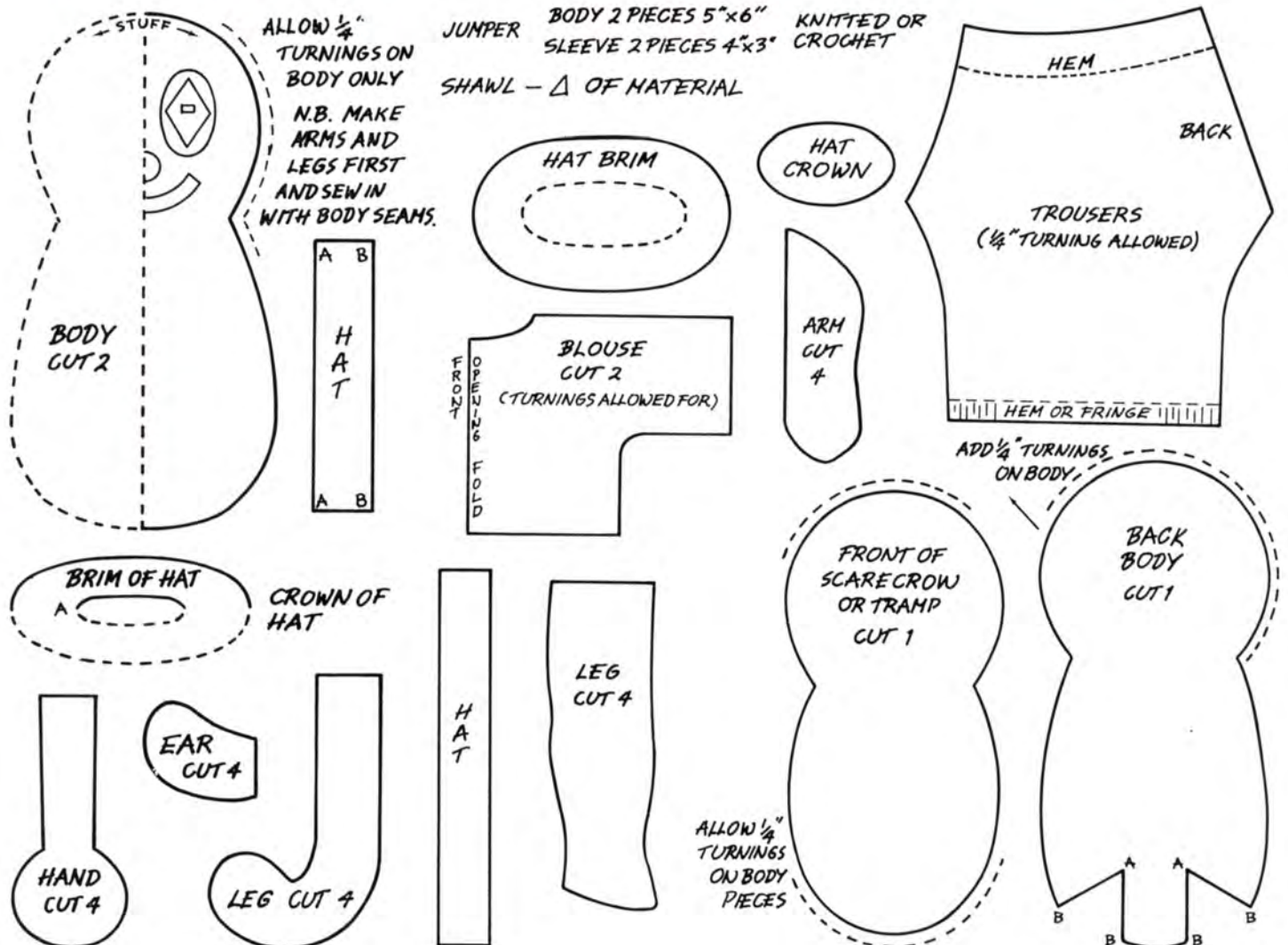





**brown dogs**



**cat**

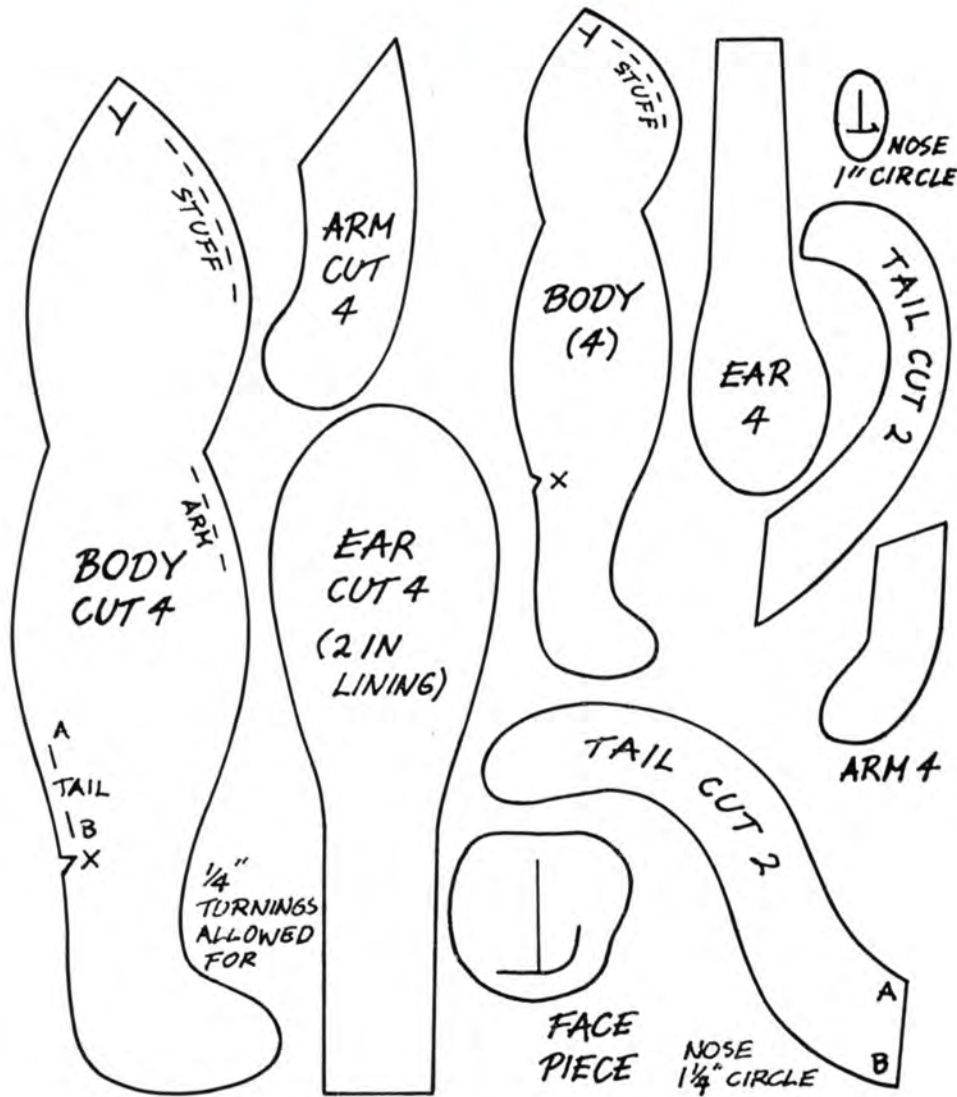

SKIRT  $3\frac{1}{2}'' \times 10''$   
 STRAPS  $3\frac{1}{2}'' \times \frac{1}{4}''$   
 BIB  $1\frac{3}{4}''$  SQUARE  
 TAIL  $\frac{1}{2}'' \times 2''$

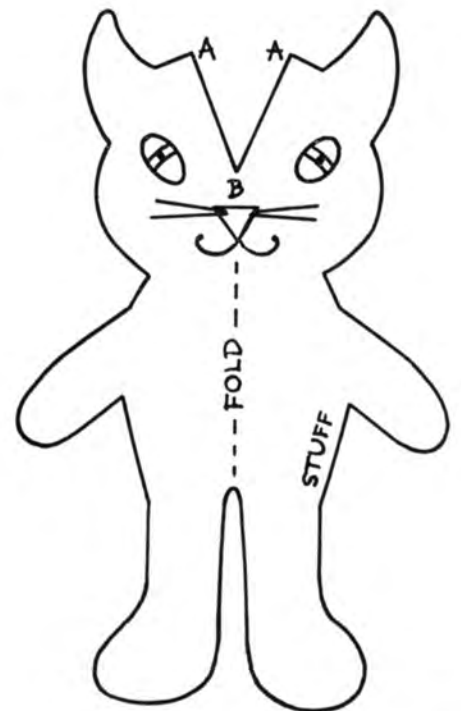





# pyjama cases

## noah's ark

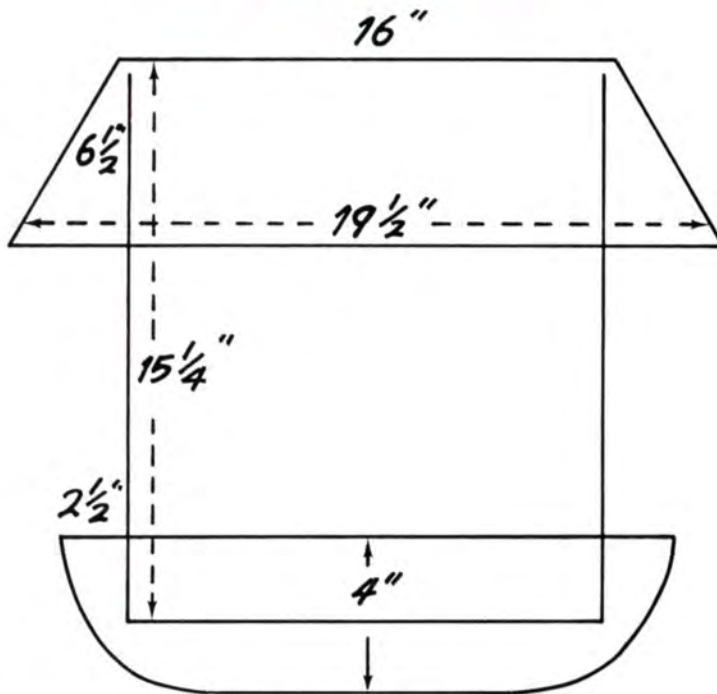

NO TURNINGS ALLOWED  
 LINING 2 PIECES 14" x 16"  
 MAIN PART MADE AS LINED BAG.  
 LINE ROOF SEPERATELY HAND SEW  
 HULL + ROOF IN POSITION.

## toadstool

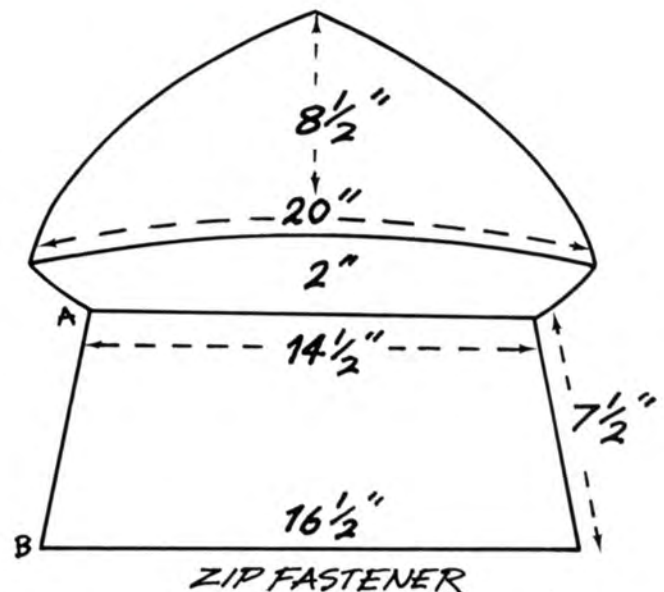

NO TURNINGS ALLOWED  
 LINING 2 PIECES 16" x 11"  
 ROUNDED AT INSIDE EDGE   
 FIX ZIP BEFORE JOINING A-B  
 -ALSO ADD LINING.







# childs hot-pants socks knee-length socks

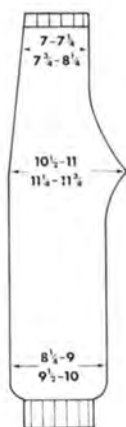
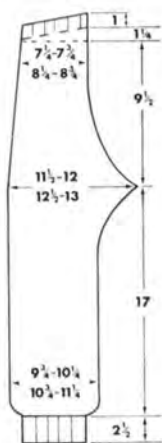

5 times in all then every foll. 28th row twice. 49 (52, 55, 58) sts. K. straight until 432 rows have been worked. K. 1 row in st. st.

### Ribbers

Transfer every alt. st. to ribber for 1x1 rib. T4/4. K. 10 rows. K. 1 loose row. Transfer ribber sts. to main bed and cast off using chain method.

### Single Machines

T5. K. 10 rows. Drop every alt. st. down 10 rows and crochet up as for 1x1 rib. Cast off loosely.

### RIGHT FRONT LEG

K. as Left Front Leg reversing all shapings.

### LEG RIB

Push 85 (92, 99, 106) needles to B position. Unravel waste wool from Left Back Leg and Left Front Leg. Pick up loops of main colour and with side seams to centre replace sts. on machine, dec. 23 sts. on Back Leg and 20 sts. on Front Leg. T6. K. 1 row.

### Ribbers

Transfer alt. sts. to ribber for 1x1 rib. T4/4. K. 24 rows. K. 1 loose row. Transfer ribber sts. to main bed and cast off using chain method.

### Single Machines

T5. K. 24 rows. Drop every alt. st. down 24 rows and crochet up as 1x1 rib. Cast off.

### TO MAKE UP

Pin out and press lightly with a hot iron over a damp cloth. Join side seams and inner leg seams to crutch, then front and back seams. Cut elastic to fit waist. Work a herringbone casing st. over elastic to inside of waistband catching every alt. st. of ribbing. Press seams.



### Materials

**Knee-length socks:** 4 (4, 5, 5) ozs. Hayfield Beaulon 4-ply wool.

**Hot-pant socks:** 6 (7, 7, 8) ozs. Hayfield Beaulon 4-ply wool. 3 stitch holders or knitting needles with points at both ends, narrow elastic.

### Measurements

Length of foot 8 (8 1/2, 9, 9 1/2) ins.

Length to bottom of heel:

**Knee length socks:** 12 (12 1/2, 13, 13 1/2) ins.

**Hot-pant socks:** 23 ins.

### Tension

12 1/2 sts. and 25 rows to 2 ins over pattern.

### Abbreviations

sts., stitches; dec., decrease; beg., beginning; alt., alternate; T., tension; 000, set row counter to 000.

### Notes

Dec. is worked by transferring the 2nd st. onto 3rd needle and moving the end st. 1 needle in.

### HOT-PANT SOCKS

Cast on 99 (99, 103, 103) sts. by hand. T7. Knit 11 rows. Make a hem and knit the row. 000. T7. Following one of the charts knit 40 rows. Adjust length here if required \*\* Dec. 1 st. (see notes) at each end of next and every following 8th row until 49 (49, 53, 53) sts. remain. Knit straight for 30 rows. Break off wool.

### Shape Foot

Slip 12 (12, 13, 13) sts. at each end onto

2 stitch holders. 25 (27) sts. remain.

### Upper Foot

Join in yarn and knit straight in pattern for 62 (68, 76, 82) rows dec. 1 st. at right side. Knit 1 row. Slip sts. onto a stitch holder. With plain side of work facing replace work on machine. Work in st.st.

### Shape Toe

\* HCL's II. Always winding wool round first needle in E position, push 1 needle at opposite end to carriage to E position on next 16 rows and back to C position on next 16 rows \*.

### Sole

Knit 56 (60, 66, 70) rows without shaping.

### Shape Heel

Knit as for toe from \* to \* Slip sts. onto a stitch holder and graft to sts. on first 2 stitch holders.

### KNEE-LENGTH SOCKS

Cast on 73 (73, 77, 77) sts. by hand. T7. Knit 11 rows. Make a hem and knit the row. 000. T7. Following one of the charts knit 30 (36, 42, 48) rows. Adjust length here if required. Now knit as hot-pant socks from \*\* to end.

### To Make Up

Pin out each sock to size and press with a warm iron over a damp cloth. Join the back seams to top of heels then side seams of foot. Press seams. Thread elastic through hem.







# father and sons lumber jackets

## father....

### Materials

16 (17, 18, 19, 20, 21) ozs. Templetons Nylonised 4-ply for knitting, 9 (10, 11, 11, 12, 13) ozs. Double Knitting for weaving, open-ended zip to fit front of jacket. A pair No. 11 knitting needles if working rib by hand.

### Measurements

To fit chest sizes 36 (38, 40, 42, 44, 46) ins. Finished measurements 38 (40, 42, 44, 46, 48) ins.

Length at back neck 25½ (26, 27½, 28, 29½, 30) ins.

Sleeve seam 17½ ins.

### Tension

12 sts. and 21 rows, to 2 ins over weaving pattern.

### Abbreviations

sts., stitches; inc., increase; dec., decrease; alt., alternate; beg., beginning; foll., following; T., tension; 000, return row counter to 000.

### BACK

**Ribbers:** Using 4-ply wool cast on 117 (123, 129, 135, 141, 147) sts. as 1 x 1 rib. T4/4. Knit 26 rows. Transfer ribber sts. to main bed.

**Hand rib:** Using No. 11 knitting needles and 4-ply wool, cast on 117 (123, 129, 135, 141, 147) sts. Work 2½ ins. in k.1 p.1 rib. Transfer sts. to machine.

**All machines:** 000. T6. Foll. chart knit 142 (142, 152, 152, 162, 162) rows.

### Shape Raglan Armholes

000. Cast off 4 sts. at beg. of next 2 rows. Knit 2 rows. Dec. 1 st. at each end of next and every following 4th row 12 (13, 13, 14, 14, 15) times in all, and then every following alt. rows until 35 (37, 39, 41, 43, 45) sts. remain. Knit 1 row. Slip sts. onto a knitting needle.

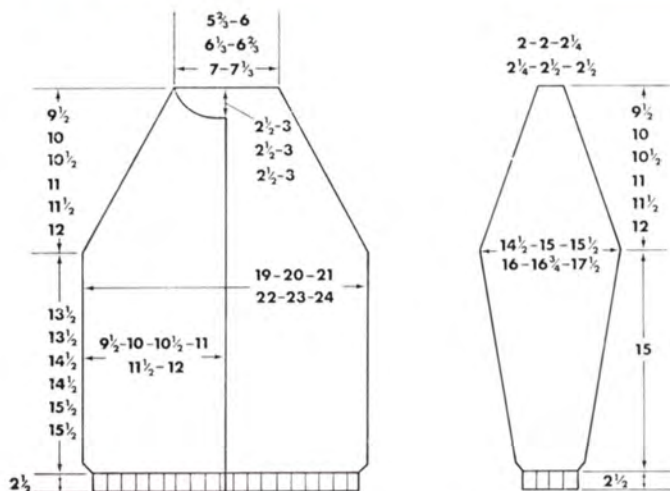







rows until 25 (26, 28, 29, 31) sts. remain. Carriage is at left.

#### Shape Neck

Cast off 5 (6, 7, 8, 9) sts. at beg. of next row. Continue raglan shaping as before, *at the same time*, knit 2 rows. Dec. 1 st. at neck edge on next and every following 4th row until 5 (5, 6, 6, 7) sts. remain. Keeping neck edge straight, continue raglan shaping until 2 sts. remain. Cast off.

#### RIGHT FRONT

Knit as Left Front reversing all shapings.

#### SLEEVES

**Ribbers:** Using 4-ply wool cast on 43 (47, 51, 55, 59) sts. as 1 x 1 rib. T4/4. Knit 20 rows. Transfer ribber sts. to main bed.

**Hand rib:** Using No. 11 knitting needles and 4-ply wool, work 2 ins in k.1, p.1 rib. Transfer sts. to machine.

**All machines:** 000. T6. Beginning on row 3 (9, 13, 19, 25) knit 10 rows. Inc. 1 st. at each end of next and every following 8th (8th, 10th, 10th, 12th) row until there are 67 (71, 75, 79, 83) sts. Knit straight until 116 (126, 136, 146, 156) rows have been worked. This will give a sleeve seam of 13 (14, 15, 16, 17) ins. If length is adjusted, the row that starts the weaving pattern must be adjusted so that the pattern will match back and front at beginning of raglan.

#### Shape Top

Cast off 2 sts. at beg. of next 2 rows. Knit 2 rows. Dec. 1 st. at each end of next and every following 4th row 8 (8, 10, 10, 11) times in all, then every following alt. row until 7 (7, 9, 9, 9) sts. remain. Knit 1 row. Slip sts. on to a knitting needle.

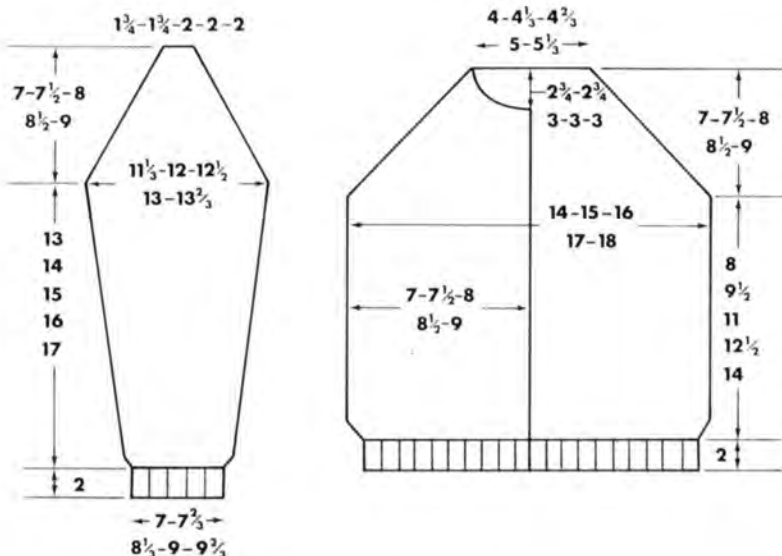

#### NECKBAND

**Ribbers:** With wrong side of work facing pick up and place on machine 21 (23, 25, 27, 29) sts. up front neck, 7 (7, 9, 9, 9) sts. from 1 sleeve, 25 (27, 29, 31, 33) sts. from back neck, 7 (7, 9, 9, 9) from 2nd sleeve and 21 (23, 25, 27, 29) sts. down front neck. 81 (87, 97, 103, 109) sts. Knit 1 row. Transfer alt. sts. to ribber. T4/4. Knit 20 rows. Knit 1 loose row. Cast off using chain method.

**Hand rib:** Using No. 11 knitting needles, pick up sts. as 'Ribber'. Work 2 ins. in k.1, p.1 rib. Cast off in rib.

#### To Make Up

Pin out and press with a hot iron over a damp cloth. Join side, sleeve and raglan seams. Fold neckband to right side and using a back-stitch sew just above cast-on row. Work 1 row of double crochet along front edges. Sew zip in position, beginning at neck edge. Press seams.

# JONES PUBLICATIONS

All the following publications are available for readers of *Stitchin' Time* to purchase direct from the editor at Britannia House, 964 High Road, Finchley, London N.12.

#### Vogue Knitting Book

This booklet contains 8 patterns produced on the Jones Lacemaker in Hayfield Wools and designed by Vogue Knitting. The patterns are designed for mother and daughter and photographed in full colour. It costs 8p.

#### Patons Machine Knits

Booklet No. 169, produced by Paton & Baldwins, is a new publication and contains 32 pages of patterns for the whole family. It costs 18p.

#### Knitting machine pattern stitch book

This hard cover manual contains over 1,200 different pattern stitches that can be produced on your machine automatically. There are 370 pages - 48 in full colour and all packed with beautiful stitches and new ideas that have never been published before. This enormous selection of fancy stitches - all with fully illustrated instruction charts - includes weaving, lace, Fair Isle, woven-lace combinations, Afghan, ribbing as well as new useful ideas on motifs, embroidery, knitting and crochet.

This manual really is a must for all knitting machine users so order yours today from the editor. It costs £2.10 plus 18p for postage. (New delivery expected January).

#### Jones Baby Book

This booklet especially produced for Jones knitting machine users, contains everything needed for the baby from birth to one year. Among the delightfully pretty garments you can make are pram suits, sleeping bags, cardigans, rompers, dresses and matinee coats making 14 patterns in all. A copy of this booklet costs 25p.

#### Jones Pattern Catalogue

As many knitting machine owners know, we also produce single and double pattern leaflets priced at 4p and 6p and as a complete guide to all the leaflets available we have now produced a catalogue of patterns. This catalogue shows a photograph of each pattern and can be obtained free of charge by sending a stamped addressed envelope to the editor.

## TWO NEW PUBLICATIONS FROM JONES

**Jones machine knit patterns with designs by Woman's Weekly** contains a range of patterns to suit the family plus attractive co-ordinates specially designed for Jones by Woman's Weekly.

The new Jones **Toddlers Pattern Booklet** features a wide range of attractive knitted garments for kiddies ages 2-6 years. A must for the knitter with a young family.

Both publications are available from the Jones Pattern Service at our Finchley address; price 15p each including post and packing.

**EDITOR:** In fact these booklets have proved so popular that a reprint has had to be ordered, so any orders received will be executed as soon as supplies are available. We will also be announcing shortly some new pattern books.







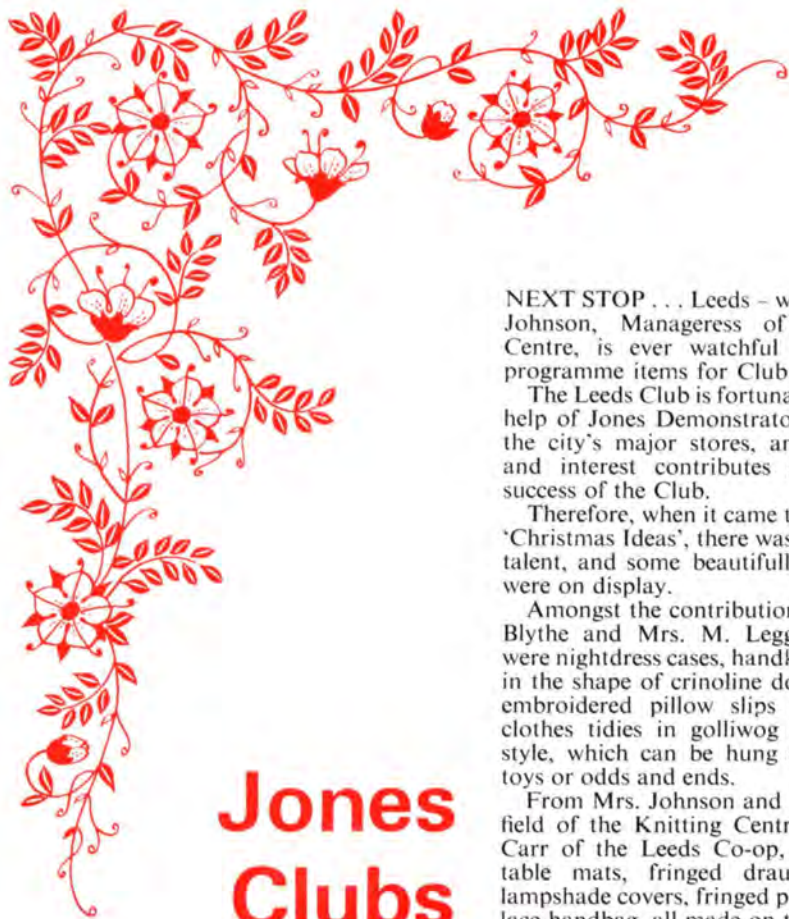

## Jones Clubs

The Jones Club Season is under way, with Area Clubs producing well organised and varied programmes. It is interesting to see that many have included items on handicrafts and we are reporting this month on one or two Clubs whose programmes have included these subjects.

At the Bondgate Memorial Hall in October, Mrs. Parkinson, our Demonstrator at Binns of Darlington, held the first meeting of the Season. The evening's programme included a practical demonstration on making lampshades, by Mrs. Wearing, who is a teacher of handicrafts; and from Mrs. Walton, a Club Member, guests were shown how to make a variety of toys from fur fabric. Instead of the usual sort of filling Mrs. Walton made economical use of shredded nylon stockings, which fill without being bulky and make the toy completely washable.

A great deal of interest was shown in the making of soft toys and Mrs. Parkinson organised a competition for the next meeting, inviting guests to make a toy of their own. A prize will be awarded to the most attractive entry, and all the toys will then be given to a Children's Charity Hospital. Not only a good idea for Christmas, but one that would be welcomed all year round.

One member of the Darlington Club, Mrs. Midwood - who came to the Club after purchasing her knitting machine from Mrs. Parkinson - has in fact won several prizes for her knitwear, including a first prize at the Darlington Show where she entered an outfit consisting of a hat, dress and jacket woven in navy and pink wool.

**NEXT STOP . . .** Leeds - where Mrs. Pearl Johnson, Manageress of our Knitting Centre, is ever watchful for interesting programme items for Club meetings.

The Leeds Club is fortunate in having the help of Jones Demonstrators from two of the city's major stores, and their energy and interest contributes greatly to the success of the Club.

Therefore, when it came to an evening of 'Christmas Ideas', there was no shortage of talent, and some beautifully-made articles were on display.

Amongst the contributions from Mrs. J. Blythe and Mrs. M. Legg of Schofields were nightdress cases, handkerchief sachets in the shape of crinoline dolls; beautifully embroidered pillow slips and children's clothes tidies in golliwog or Dutch doll style, which can be hung and filled with toys or odds and ends.

From Mrs. Johnson and Mrs. J. Bloomfield of the Knitting Centre and Miss F. Carr of the Leeds Co-op, came dressing table mats, fringed draught excluders, lampshade covers, fringed place mats and a lace handbag, all made on the 588 knitting machine.

Mrs. Johnson also organised a small fashion show, during which fourteen Club Members modelled suits, dresses and coats which they had made themselves. One outfit of particular note was made and modelled by the twelve-year-old daughter of a Club Member. It consisted of deep plum-coloured trousers with matching jumper, worn under a longline fair isle sleeveless cardigan; the whole outfit topped by a matching peaked cap.

An eye-catching outfit which would earn praise for a knitter of any age.

**NORTH OF THE BORDER . . .** For news of the Motherwell Club which saw a change of venue in September from the Y.M.C.A. Hall, to the premises of our Main Dealer in the area, David Watson and Son.

The evening was hosted by Mr. Watson and Mrs. J. Macdonald, our Area Tutor and Club Secretary. Mr. Watson provided full Club facilities for his guests who were able to purchase patterns from his range, and enjoy demonstrations of all Jones machines.

For the next meeting, guests will bring a recently-knitted garment and also any unusual patterns which they have learned to knit.

Mrs. Macdonald is herself an expert knitter and enjoys her work tremendously. "It's such good fun" she wrote recently, "So many people come with their problems and queries, and I'm glad I'm able to help in any way I can."

As our Area Tutor, Mrs. Macdonald, has in fact, taught a number of men to use the knitting machine and she has since learned that several of them have turned their knitting ability into a profitable hobby.

**STILL NORTH . . .** The Ayr Club started the season with a new Club Secretary, Mrs. Jane Macdonald, our Demonstrator at Houstons of Ayr. Backed by a hard-working Committee, the Club has organised enjoyable evenings for Members, and the last meeting included a demonstration of toy-making and basket-weaving given by three members of the Senior Occupational Centre in Ayr, for mentally handicapped children.

**LEICESTER . . .** At the hub of the wool and hosiery industry, you might well expect to find a Jones Club - and you would. Held in Oadby, the Club is run by our energetic Club Secretary, Mrs. Mirams, who seems to produce a never ending supply of ideas and schemes to keep Club Members on their toes.

Curious as to how she managed to secure so many good demonstrations and talks from outside firms and organisations, I asked her how she started. Many of the ideas have come out of general Committee meetings, where a copy of Yellow Pages is often to be seen. By contacting suitable companies and organisations listed in the book, Mrs. Mirams and her Committee have secured a variety of demonstrations ranging from the more usual millinery, floral, cookery and needlework, to a lecture from a beautician and a talk from the local Fire Brigade on home safety! A representative of the International Wool Secretariat has also given a talk at the Club, and Coats presented a needlework lecture during last Season.

Our Main Dealer for Leicester, Mr. R. L. Gent, was invited to the first meeting of the Season, since guests had particularly requested demonstrations of Jones sewing machines. He was joined by our Mobile Demonstrator, Miss Sheila Martson, who demonstrated a Knitleader attachment, and, in fact, the evening's programme was so full that there was insufficient time to show the colour slides of the Jones '71 Fashion Collection, and these had to be left until the next meeting.

One idea which we would like to pass on to other Clubs has originated from Leicester, where members bring a knitted square to every meeting. The squares are then made into blankets and given to local hospitals and other charitable organisations. In this way some useful results are produced at a very small cost to each member.

**HOME GROUND . . .** Over a year ago a small Club started in Oving Road, Chichester, under the guidance of Mrs. G. Parker, our Area Tutor. Since that time, the Club has grown and membership now totals thirty.

The Club has become a regular meeting place, and the friendly informality quickly puts the shyest newcomer at ease. Everyone mixes in to share their experience in knitting sewing and handicrafts, and Mrs. Parker gives expert help at every session.

Once a month, Mrs. Whittington of Hampshire comes over to the Club to teach needlework, and in fact, new subjects have been introduced over the months so that it is now possible to learn a selection of handicraft skills.

*continued on page 26*



Club Secretary :	Venue	Dates
<b>ABERDEEN</b> Mrs. C. Davidson, Hillhead of Mosstown, Udry, Aberdeen.	Bon Accord Hotel, Market Street, Aberdeen.	
<b>AYR</b> Mrs. J. Macdonald, 5 Coronation Street, Monkton, Ayrshire.	The Station Hotel, The Station, Ayr. Start: 7.30 p.m.	
<b>BIRMINGHAM</b> Mrs. D. Taylor, Birmingham Knitting Centre, 1st Floor, Somerset House, Temple Street, Birmingham 2.	The Alston Suite, Post Office Social Club, Thorp Street, Birmingham 5. Start: 7.30 p.m.	
<b>BRIGHTON</b> Mrs. E. Whitaker, Bristol Lodge, Bristol Gate, Brighton, Sussex.	10 Hillside, Moulscoombe, Brighton, Sussex. Start: 6.30 p.m.	December 27th
<b>BRISTOL</b> Mrs. J. Bolwell, Ivanhoe Lodge Lane, Wraxhall, Nr. Bristol BS19 1BQ.	Quakers Hall, Gloucester Road, (Cnrr. Radnor Road), Bristol. Start: 7.00 p.m.	
<b>BROMLEY</b> Mrs. G. Dalton, 13 New Farm Avenue, Bromley, Kent.	The Soames Room, St. Marks Hall, Masons Hill, Bromley, Kent. Start: 7.45 p.m.	
<b>BLACKPOOL</b> Mrs. Beaumont, 5 Scarborough Road, St. Annes-on-Sea, Lancs.	Highlands Hotel, Promenade, Bispham, Blackpool. (Opp. Red Bank Road Tram Stop).	December 13th Start: 8.00 p.m.
<b>CHICHESTER</b> Mrs. E. G. Parker, 118 Oving Road, Chichester, Sussex.	118 Oving Road, Chichester, Sussex. Start: 6.30 p.m. This Club meets once a fortnight.	
<b>CHRISTCHURCH</b> Mrs. Turner, 25 Queen Road, Christchurch, Hants.	N.A.D.'s Club, Bridge Street, Christchurch. Start: 7.30 p.m.	December 15th
<b>DARLINGTON</b> Mrs. J. Parkinson, 161 Kingsway, Salters Lane, Darlington.	Bondgate Memorial Hall, Darlington.	
<b>DERBY</b> Mrs. A. Buchan, 287 Uttoxeter Road, Mickleover, Derby.	Large Club Room, The Guildhall, Market Place, Derby. Start: 7.30 p.m.	
<b>DURHAM</b> Mrs. Keefe, 16 Marlene Avenue, Bowburn, Durham.	Shakespeare Hall, North Road, Durham City. Start: 7.00 p.m.	
<b>EMSWORTH</b> Mrs. Whittington, 37 Clovelly Road, Southbourne, Nr. Emsworth, Hants.	Chidham Village Hall, Main Road, Nutbourne, Nr. Chichester. Start: 7.30 p.m.	December 15th
<b>GT. YARMOUTH</b> Mrs. N. Scott, Jones Demonstrator, Arnolds Limited, King Street, Gt. Yarmouth.	31 Northgate Street, Gt. Yarmouth. Start: 7.30 p.m.	
<b>HARROW</b> Mrs. Janes, 6 Kingsway Crescent, North Harrow, Middx.	North Harrow Assembly Hall, Station Road, N. Harrow HA2 6BG Start: 8.00 p.m.	
<b>HULL</b> Mrs. E. Parrott, 16 Westcott Street, Holderness Road, Hull HU8 8LR	Young People's Inst., George Street, Hull. Start: 7.30 p.m.	December 30th
<b>LEEDS</b> Mrs. P. Johnson, Jones Knitting Centre, Holbeck Chambers, 101 The Headrow, Leeds 1.	Co-op. Restaurant, 10 Albion Street, Leeds 1. Start: 7.30 p.m.	
<b>LEICESTER</b> Mrs. D. Mirams, 130 Harborough Road, Oadby, Leicester LE2 4LD.	Oadby Boys Club Hall, Wigston Road, Oadby, Leicester. Start: 7.30 p.m.	December 16th
<b>LOWESTOFT</b> Mrs. E. Shanahan, 18 The Avenue, Lowestoft, Suffolk.	18 The Avenue, Lowestoft. Start: 7.30 p.m.	
<b>NORTHAMPTON</b> Mrs. S. Rees, 18 Prince Street, Earls Barton, Northampton.	Y.M.C.A., Cheyne Walk, Northampton. Start: 7.30 p.m.	
<b>NORWICH</b> Mrs. Caston, 28 Winchester Tower, Norwich.	The Chantry Merrit Room, Norwich. Start: 7.30 p.m.	
<b>PATRICROFT</b> Mrs. D. Box, 13 Green Lane, Patricroft, Manchester, M30 0RP.	13 Green Lane, Patricroft, Manchester, M30 0RP. Start: 7.30 p.m.	Every Monday Evening
<b>ROMFORD</b> Mrs. D. Ellis, 28 Hall Road, Chadwell Heath, Essex.	Wykeham Hall, Market Place, Romford, Essex. Start: 7.30 p.m.	December 16th
<b>SHEFFIELD</b> Mrs. Fletcher, Pauldens Ltd., Manchester.	St. Mary's Church, Bramall Lane, Sheffield.	

Dates for club dates in 1972 will be published as soon as available.

As Christmas is upon us there are not many club meetings that have been arranged during December. As soon as fixtures for 1972 have been agreed we will publish them in 'STITCHIN' TIME'.



continued from page 24

But it is not only the variety of subjects and help available which brings members back – they come for the good comradeship and humour which inevitably breaks through the evening. "A good evening and good company" is how one member describes Club meetings.

I invited Mrs. Parker to let me have a few notes on how the Club started, and she in turn extended the invitation to her members, who then wrote to me. I received some delightful accounts of how members came to join the Club, and one thing that came through very strongly in all the letters, was how much they all enjoyed the informal atmosphere in Mrs. Parker's home – and also how much they could learn in these relaxed surroundings.

One member wrote that she had become interested in the first place by seeing the many lovely things made, so that she felt she wanted to do something rewarding for herself. As one lady wrote: "It's a pleasure to come for an evening and learn something which you can do all your life and not forget. It's a pity more people are not interested in starting a small Club of their own."

**JUST BRIEFLY . . .** Members of the Norwich Club have started groups for crochet and tatting and Mrs. Caston, Club Secretary, reports that at the last meeting, Members were so absorbed that they were still working after 10 p.m. without a break.

. . . Tunbridge Wells Club has gained a new Club Secretary, Mrs. F. Noakes, who has taken over from Mrs. Springett.

Mrs. Noakes is planning a series of dress-making classes for Club Members, and we extend best wishes to her for future Club activities. We are pleased to hear that Mrs. Springett will still attend meetings; the Club owes much of its popularity to her past efforts.

. . . After waiting for tickets since July, thirty members of the Harrow Club went to the London Weekend studios in Wembley to see the programme "Please Sir!" as it was taped. A long wait, but worthwhile, we hope.

. . . The Christchurch Club, run by Mrs. C. Turner, has not been slow in securing the interest of the local press and has received two write-ups in the past few months, giving details of demonstrations, garments displayed and fashion shows. We wonder – does your local press know of your activities?

**WELCOME . . .** to a new Club which opened in September at Inverness. The Club is to be run by Mrs. Abraham, Jones Demonstrator at Benzies Department Store, helped by Mrs. Davidson, Area Tutor. For the first meeting our Supervisor Mrs. J. Sang came along, together with Mrs. N. Defelice, Manageress of the Glasgow Knitting Centre, who travelled overnight to Inverness to attend the Club. We hear that the first meeting was a great success, and extend best wishes for future meetings.

**Beverly  
Martin**

# mans sleeveless pullover

WITH FAIR ISLE INSERTION





### Materials

11 (12, 12, 13, 13, 14) ozs. Sirdar Double Knitting in Main. M. 1 oz. in Contrast. C.

### Measurements

To fit chest sizes 36 (38, 40, 42, 44, 46) ins. Finished measurements 38 (40, 42, 44, 46, 48) ins.  
Length to shoulder 22 (22½, 23, 23½, 24, 24½) ins.

### Tension

13 sts. and 17 rows to 2 ins. after pressing.

### Abbreviations

Sts., stitches; dec., decrease; inc., increase; beg., beginning; alt., alternate; H.C.L's, Holding cam levers; T., tension; 000, set row counter at 000.

### Notes

A few samples of Fair Isle are given to show that any pattern with a repeat of 4 or 8 sts. can be used. If bands of Fair Isle are worked up the garment less wool in main colour will be used, the extra being needed in the contrast colour.

### BACK

**Ribbers.** Using M. Cast on 125 (131, 137, 145, 151, 157) sts. as 1×1 rib. T6/6. Knit 12 rows. Transfer sts. to main bed.

**Mock rib.** Using waste wool, cast on 63 (66, 69, 72, 75, 78) sts. on alt. needles. Knit a few rows. Change to M. T8. Knit 23 rows. Make a hem and knit the row.

**All machines.** 000. T10. Knit 4 rows. Following one of the Fair Isle charts knit number of rows given. Using M. only knit until 94 rows in all have been worked. This will give a length of 12½ ins. from beginning. Adjust length here if required.

### Shape armholes

000. Cast off 6 (6, 7, 7, 8, 8) sts. at beg. of next 2 rows. Dec. 1 st. at each end of next 9 (9, 9, 11, 11, 11) rows\* then every alt. row until 85 (89, 93, 97, 101, 105) sts. remain. Knit straight until 76 (80, 84, 88, 92, 96) rows have been worked.

### Shape shoulders

Cast off 5 sts. at beg. of next 8 rows and 4 (5, 6, 7, 8, 9) sts at beg. of next 2 rows. Slip sts. onto a knitting needle.

### FRONT

Knit as given for Back to \*

### Divide for neck

Transfer centre st. onto adjacent needle. Push needles at left to E position H.C.L's III Knit the right side first. Dec. 1 st at armhole edge on next and every following alt. row 5 (6, 6, 5, 5, 6) times in all, *at the same time* Knit 2 rows. Dec. 1 st. at neck edge on next and every following 3rd row 9 (9, 9, 11, 11, 11) times in all then every 4th row until 24 (25, 26, 27, 28, 29) sts. remain. Knit 1 row.

### Shape shoulder

Cast off 5 sts. at beg. of next and alt. rows until 4 (5, 6, 7, 8, 9) sts. remain. Knit 1 row. Cast off H.C.L's III: Knit left side to match right side reversing all shapings.

### NECKBAND

With wrong side facing pick up and place on machine 37 (39, 41, 43, 45, 47) sts. from back neck and 60 (62, 66, 68, 72, 74) sts. down right front neck. 97 (101, 107, 111, 117, 121) sts. Knit 1 row.

X	X	X		X	X			13
	X	X	X		X	X		12
		X	X	X		X	X	11
X			X	X	X		X	10
X	X			X	X	X		9
	X	X			X	X	X	8
	X	X			X	X	X	7
	X	X			X	X	X	6
X	X			X	X	X		5
X			X	X	X		X	4
		X	X	X		X	X	3
	X	X	X		X	X		2
X	X	X		X	X			1
1	2	3	4	5	6	7	8	

X=CONTRAST

		X						34
		X						33
	X	X	X					32
	X	X	X					31
		X						30
		X						29
X				X				28
X				X				27
X	X		X	X				26
X	X		X	X				25
X			X	X	X	X	X	24
X			X	X	X	X	X	23
X			X					22
X			X					21
					X			20
					X			19
				X	X	X		18
				X	X	X		17
				X	X	X		16
				X				15
				X				14
				X				13
X	X	X	X	X	X	X	X	12
X	X	X	X	X	X	X	X	11
	X			X				10
	X			X				9
	X	X	X	X	X	X	X	8
	X	X	X	X	X	X	X	7
X	X	X		X	X	X		6
	X			X				5
								4
								3
X	X	X		X	X	X		2
	X	X	X		X	X	X	1
1	2	3	4	5	6	7	8	

X=CONTRAST

**Ribbers.** Transfer alt. sts. to ribber. T6/6 \* Transfer 3rd st. on each bed onto 4th needle at front neck edge. Move the end 2 sts. 1 needle in. Knit 2 rows. Repeat from \* 3 times more. Transfer sts. to main bed and cast off. With wrong side facing pick up 60 (62, 66, 68, 72, 74) sts. along left front edge. Knit to match first side.

**Single machines.** Pick up sts. as "Ribber" T9. Knit 1 row. Transfer 3rd st. onto 4th needle at front neck edge. Move the end 2 sts. 1 needle in. Knit 1 row. Repeat the last row 7 times more. Knit 1 row. Move the end 2 sts. 1 needle out and pick up loop and place on empty needle. Knit 1 row. Repeat last row 7 times more. Cast off loosely. Pick up sts. along left front edge and knit to match first side.

### ARMBANDS

Join shoulder seams. With wrong side facing pick up and place on machine 127 (131, 135, 139, 143, 147) sts. Knit 1 row.

**Ribbers.** Transfer alt. sts. to ribber T6/6. Knit 8 rows. Transfer sts. to main bed and cast off.

**Single machines.** Pick up sts. as "Ribber" T9. Knit 1 row. Dec. 1 st (as on neckband) on next 8 rows. Knit 1 row. Inc. 1 st. on next 8 rows. Cast off.

### To make up

Pin out and press with a hot iron over a damp cloth stretching Fair Isle band out to same measurements. Join side seams. Join mitre at front neck.

**Single machines.** Turn neckband and arm-bands to wrong side and slip stitch in place. Press seams.

	X		X	X	X			22
X		X		X	X			21
								20
								19
	X			X				18
X	X	X		X	X	X		17
	X	X	X	X	X	X		16
	X	X	X	X	X	X		15
	X			X				14
	X			X				13
X	X	X	X	X	X	X	X	12
X	X	X	X	X	X	X	X	11
	X			X				10
	X			X				9
	X	X	X	X	X	X	X	8
	X	X	X	X	X	X	X	7
X	X	X		X	X	X		6
	X			X				5
								4
								3
X	X	X		X	X	X		2
	X	X	X		X	X	X	1
1	2	3	4	5	6	7	8	



# playsuit



## Materials

7 (8, 9, 10) ozs. Hayfield Beaulon 4-ply in main colour M. 1 oz. in contrast C. 18-inch zip. A pair No. 11 Knitting needles.

## Measurements

To fit bust sizes 30 (32, 34, 36) ins.

To fit hip sizes 32 (34, 36, 38) ins.

Finished measurements: Bust 30 (32, 34, 36) ins.

Hips 32 (34, 36, 38) ins.

Length from crutch to shoulder 24 (24½, 25½, 26) ins.

Sleeve seam 2½ ins.

## Tension

14 sts. and 19 rows to 2 ins. after pressing.

## Abbreviations

Sts., stitches; inc., increase; dec., decrease; alt., alternate; beg., beginning; H.C.L., holding cam lever; T., tension; 000, set row counter to 000.

## Notes

Coloured spots are knitted at random and not in any special position.

## Spot in contrast colour

### FRONT

Cast on 16 (18, 18, 20) sts. by hand. T7. Knit 2 rows. Cast on 3 sts. at beg. of next 6 rows, 4 sts. at beg. of next 14 rows, 6 sts. at beg. of next 2 (2, 4, 4) rows and 6 (8, 6, 8) sts. at beg. of next 2 rows. 114 (120, 128, 134) sts. Knit straight for 16 rows. Dec. 1 st. at each end of next and every following 12th row until 106 (112, 120, 126) sts. remain. Knit until 82 (84, 88, 90) rows have been worked. Transfer every alt. st. on to adjacent needles. Push empty needles to A position. T5. Knit 28 rows. Push empty needles to B position. Take loop from adjacent st. and place on empty needles. T6. Knit 24 rows. T7. Knit straight until 166 (170, 174, 178) rows have been worked.

### Shape Armholes

000. Cast off 5 sts. at beg. of next 2 rows. Dec. 1 st. at each end of next 7 rows then every following alt. row until 78 (84, 90, 96) sts. remain. Knit straight until 32 (34, 36, 38) rows have been worked.

### Shape Neck

Using odd length of wool, cast off 16 (18, 20, 22) sts. at centre. Push needles at left to E position. Knit the right side first. H.C.L.'s III. \* Knit 1 row. Dec. 1 st. at neck edge on next 4 rows then every alt. row 4 times. Knit 3 rows. Dec. 1 st. at neck edge on next and following 4th row. 21 (23, 25, 27) sts. Knit straight until 62 (64, 66, 68) rows have been worked.

### Shape Shoulder

Cast off 6 sts. at beg. of next and alt. rows until 3 (5, 7, 9) sts. remain. Knit 1 row. Cast off. H.C.L.'s I. Rejoin wool at armhole edge and knit to match right side from \*.

### LEFT BACK

Cast on 12 (13, 13, 14) sts. by hand. T7. Knit 2 rows (Knit 1 row only for Right Back). Cast on 3 sts. on next and alt. rows 7 times in all, 4 sts. on following 3 alt. rows, 6 sts. on following 1 (1, 2, 2) alt. rows and 6 (8, 6, 8) on following alt. row 57 (60, 64, 67) sts. Knit straight for 16 rows. Dec. 1 st. at right side on next and every following 12th row until 53 (56, 60, 63) sts. remain. Knit straight until 81 (83, 87, 89) rows have been worked. (Knit 1 row extra for Right Back).

### Shape Back

H.C.L.'s III. Always winding wool round first needle in E position, push 14 needles at right to E position on next and alt. rows 3 times in all. Knit 1 row. H.C.L.'s I. Knit 1 row. Transfer alt. sts. on to adjacent needles. Push empty needles to A position. T5. Knit 28 rows. Push empty needles to B position. Take loop from adjacent st. and place on empty needle. T6. Knit 24 rows.

T7. Knit straight until 166 (170, 174, 178) rows have been worked.

### Shape Armhole

000. Cast off 5 sts. at beg. of next row. Knit 1 row. Dec. 1 st. at armhole edge on next 7 rows, then every alt. row until 39 (42, 45, 48) sts. remain. Knit straight until 62 (64, 66, 68) rows have been worked. (Knit 1 row extra for Right Front).

### Shape Shoulder and Neck

Cast off 6 sts. at beg. of next row. Cast off 6 (7, 8, 9) sts. at beg. of next row. Cast off 6 sts. at beg. of next 4 rows: Cast off remaining 3 (5, 7, 9) sts.

### RIGHT BACK

Knit as Left Back reversing all shapings.

### NECKBAND - Ribbers

With wrong side facing, pick up and place on machine 16 (18, 20, 22) sts. across half back neck, 28 sts. down front neck 16 (18, 20, 22) sts. across front neck, 28 sts. up front neck and 16 (18, 20, 22) across other half back 104 (110, 116, 122) sts.













# Jones Course

## Lesson 5

### BIAS OR CROSSWAY

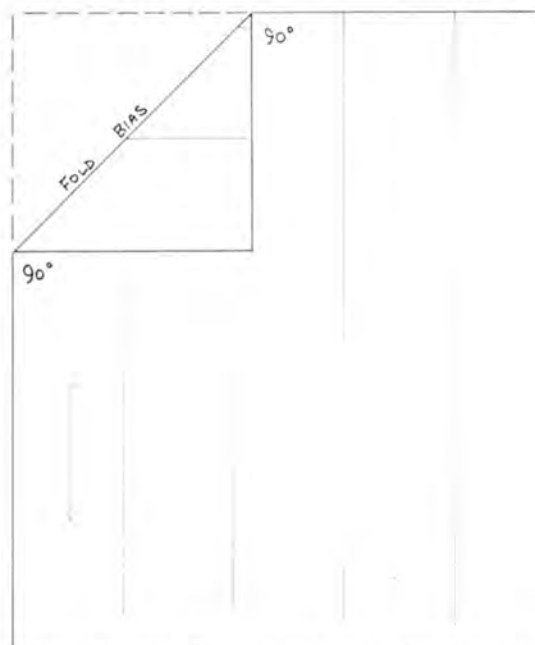

1. Fold the fabric over forming a right angle at each corner with the folded edge lying diagonally across the warp and weft of the fabric. Woven fabrics are quite firm running down the selvedge and across the width. Cutting across the bias produces a fabric which has a great amount of stretch to it. This feature can be used in many ways in garment design and construction. Bias cut garments drape beautifully and bias cut checks and stripes can be very attractive.

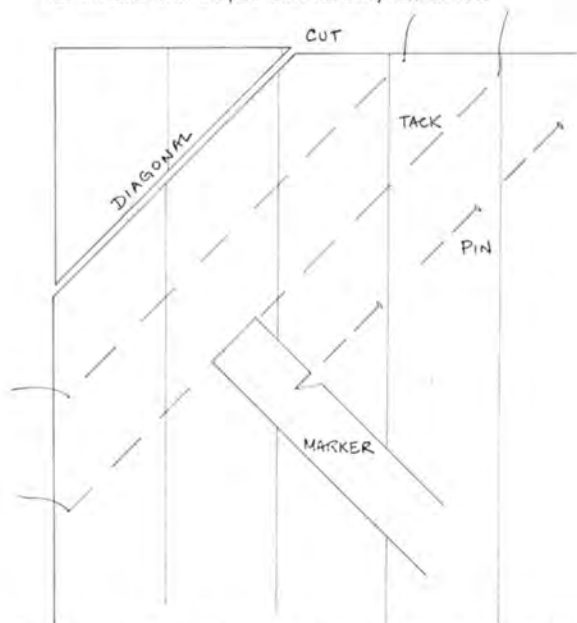

2. **Cutting Bias Strips.** Cut along the diagonal fold using a width marker cut from a piece of card. Measure from the folded edge pinning and tacking if necessary. Avoid chalking as the fabric will be inclined to stretch.

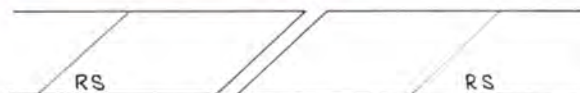

3. Joining bias strips with the RS uppermost and cut ends parallel. Place the two pieces flat on the table.

4. Fold one over the other the RS facing. Slide the top piece along until the points of joining are matching exactly. Machine  $\frac{1}{4}$ " away from the edge.

5. Press open. Trim away the projecting points to make a continuous line top and bottom.

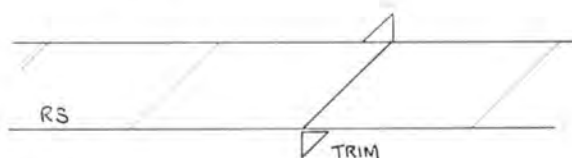
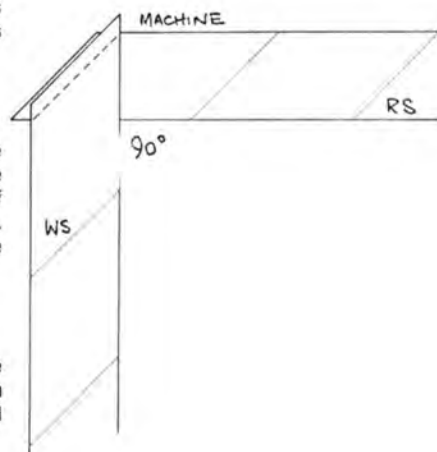

### 6. Rouleau

Fold the bias strip in half and machine  $\frac{1}{8}$ " for button loops.  $\frac{1}{4}$ "- $\frac{1}{2}$ " away from the folded edge for belts and trimmings. Trim down the seam to  $\frac{1}{8}$ " unless it is required to pad out the rouleau as in a tie belt. Secure one end with a firm thread to a bodikin and pass through the tube to draw this through to the R Side.

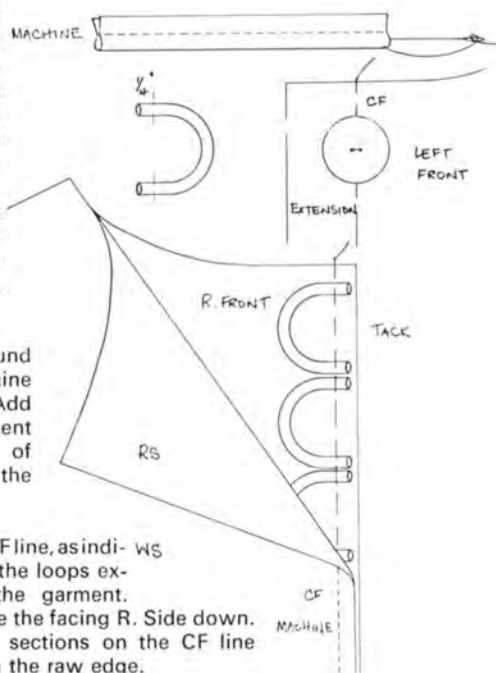

### 7. Button Loops

Place the rouleau round the button to determine the required length. Add  $\frac{1}{2}$ " to this measurement and cut the number of loops required. Stitch the button to the CF line.

8. Position these on the CF line, as indicated in the diagram, the loops extending inwards to the garment. Tack into position. Place the facing R. Side down. Machine through the sections on the CF line which is  $\frac{1}{4}$ " away from the raw edge.



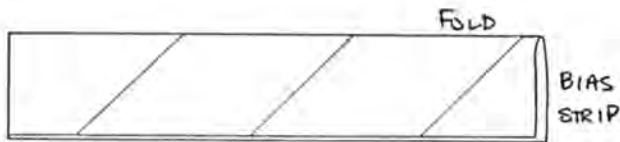

**9. Bias Piping**

Cut a bias strip twice the width required plus 1".  
Fold in half.



10. Pass the piping cord between the fold and tack into position. The size of the cord, the thickness, will depend on the application of the bias piping. For example, loose covers in upholstery would require a much thicker cord to that of a fine piped seam of a woman's garment.

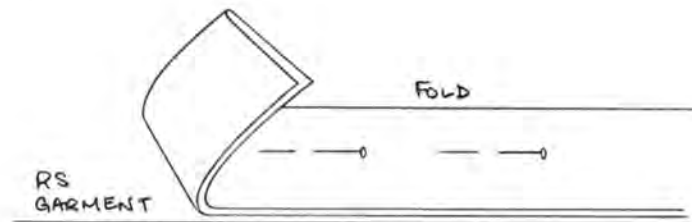

11. Place the folded bias strip (with or without cord) on to the garment, raw edges matching.

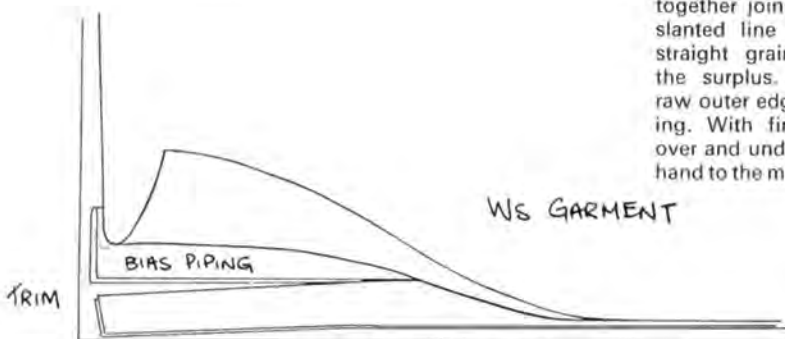

12. Place the second section of the garment over this and machine through the fitting line. It will be necessary to use a zipper foot to be able to machine close up to the cord.

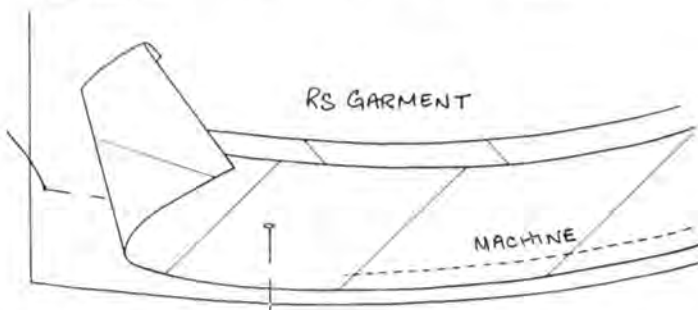

13. **Bias Hem** – used as a false hem to lengthen a garment. If possible allow  $\frac{3}{4}$ " below the hemline. Place the bias strip, R. Sides together, along the lower edge. Machine  $\frac{3}{4}$ " from this edge.

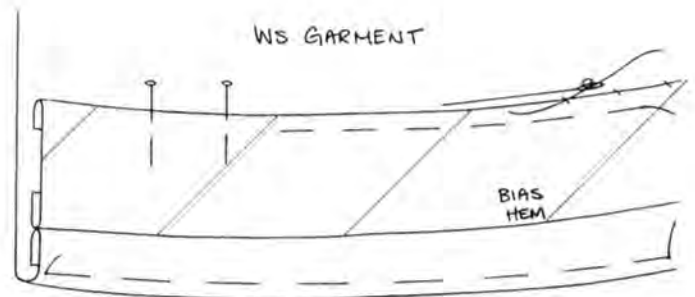

TACK ON THE HEM LINE

14. Fold back and tack on the hemline. Pin, tack and hem the top edge of the bias strip. Bias binding can be bought by the yard and in many colours but it is only narrow in width. However, it is very useful for certain aspects of dressmaking.

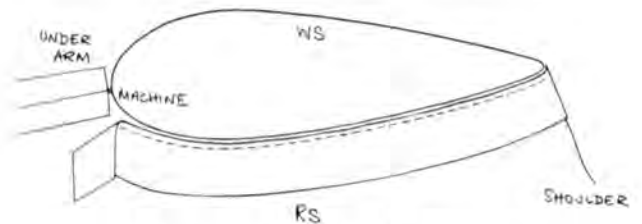

**15. Neck or Armhole Binding**

Place the binding with the raw edges together. (Only use self or contrasting fabric for this type of binding.) Begin to machine 1" to the front of the underarm seam and  $\frac{1}{2}$ " away from the raw edge. Machine to within the same distance the other side of the underarm seam.

16. Remove from the machine. Pin the two bias strips together joining across the slanted line which is the straight grain. Trim away the surplus. Overlock the raw outer edge of the binding. With fine fabric turn over and under and hem by hand to the machining.

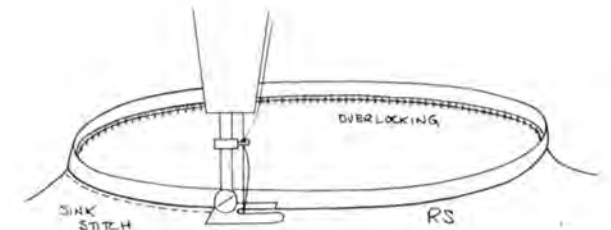
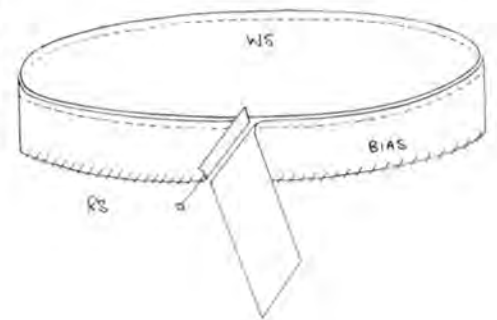

17. **Sink Stitching** – This is a useful method of binding the armhole producing a very neat and flat finish, also eliminating the time spent on handsewing. Place the garment under the machine R. Side uppermost. Fold the binding over. The free arm machine is particularly useful for this process. Bring the needle down to insert to the immediate left of the fold, sinking the stitch into the garment but not onto the binding.





# TAILOR TACKS

1. **Tailor Tacks.** These are temporary stitches used to transfer the markings of a pattern on to both sides of the garment. Use double thread (60's thread has a fluffy surface which will cling to the fabric) and begin by leaving  $\frac{1}{2}$ "- $\frac{3}{4}$ " of thread extending at the end. Loop the stitch over backwards. Cut at each stitch, with single tacks, and at the completion of the line (as with a CF marking) with continuous tacks.

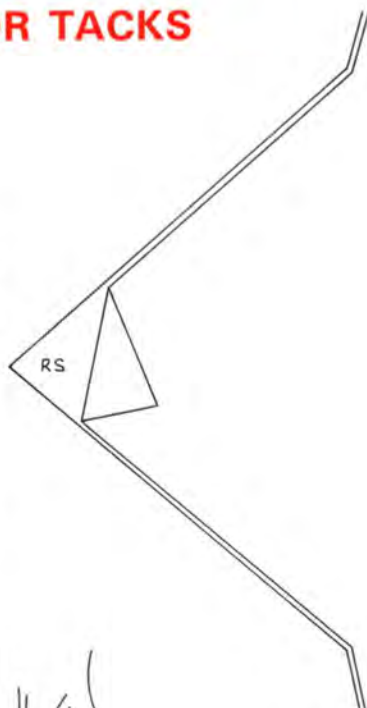

SINGLE TAILOR TACKS



WS GARMENT

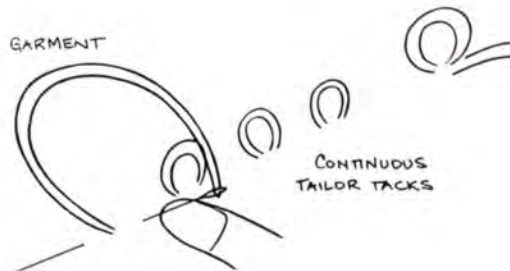

CONTINUOUS TAILOR TACKS

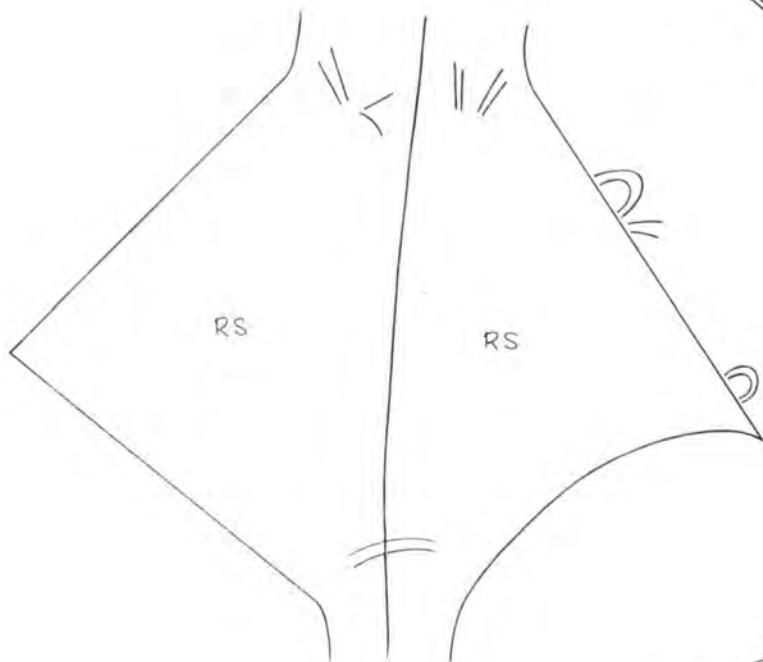

2. Pull the two sections of garment apart and cut through the centre of the tailor tacks.

3. **Trace Tacking** - Temporary stitches mostly used on fine fabrics for marking fitting lines, buttonhole and pocket positions. Single thread or single fabric beginning with a knot and stitching outside the point to be marked. Cut the thread at the completion of each line beginning the second one crossing over the first. In this way the corners will be accurately marked and each thread can be easily removed by drawing from the knotted end.

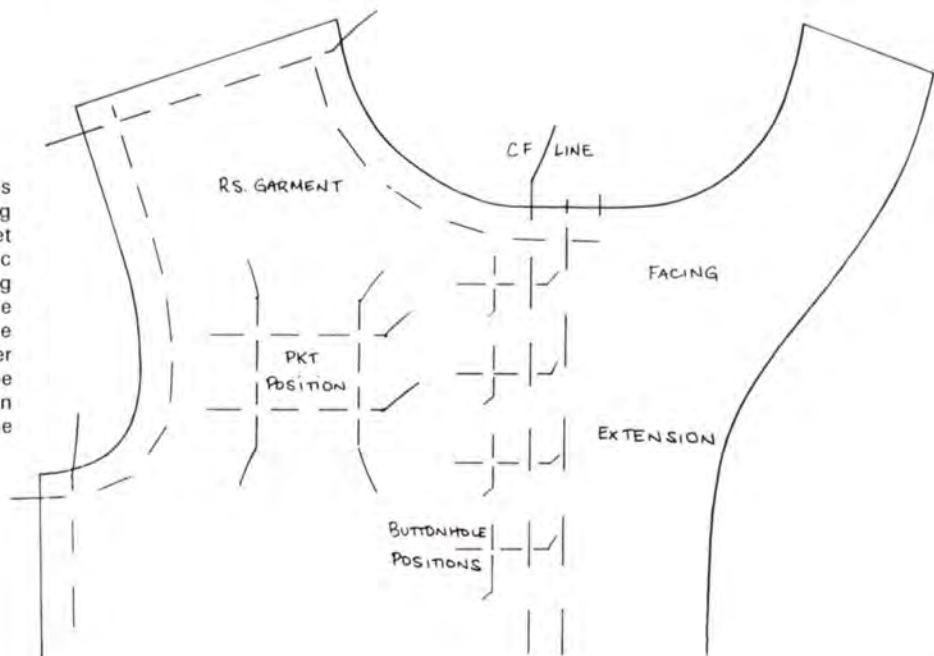





WS GARMENT

4. Flat Tacking – Temporary stitches, single thread, used to hold two parts of a garment together in preparation for fitting or machining.

5. Flat Tacking – used to position and secure the hemline of a garment. The first row of tacking is  $\frac{1}{4}$ " from the folded edge. This ensures that the hemline is exact. The second row of tacking  $\frac{1}{4}$ " from the top edge. (Do not press over tacks or pins.) Take up  $\frac{1}{4}$ "– $\frac{3}{8}$ " of fabric leaving  $\frac{1}{2}$ "– $\frac{3}{4}$ " space between each stitch.

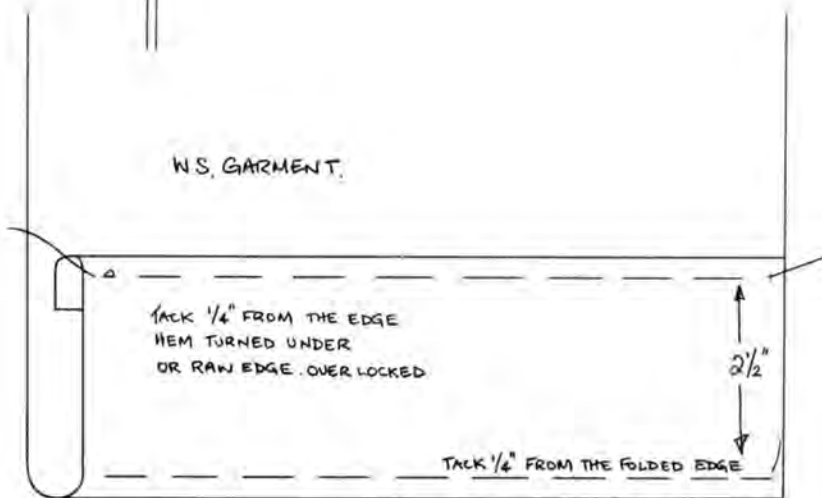

WS GARMENT

TACK  $\frac{1}{4}$ " FROM THE EDGE  
HEM TURNED UNDER  
OR RAW EDGE OVER LOCKED

$2\frac{1}{2}$ "

TACK  $\frac{1}{4}$ " FROM THE FOLDED EDGE

RS GARMENT

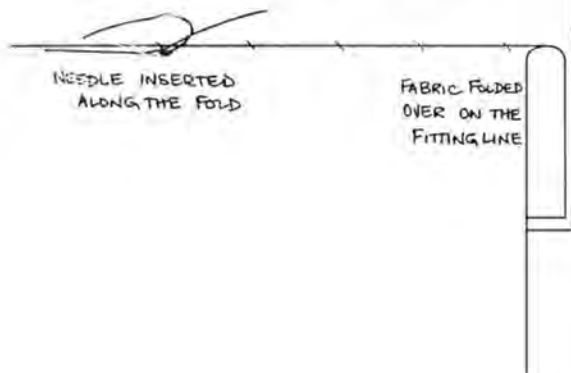

NEEDLE INSERTED  
ALONG THE FOLD

FABRIC FOLDED  
OVER ON THE  
FITTING LINE

6. Slip Tacking – Temporary stitches, single thread, used to join a garment together from the Right Side. This is particularly useful when making alterations during a fitting session, inserting a sleeve or matching checks and stripes from the right side. Fold one side of the fabric over on the fitting line. Place this on to the fitting line of the underside. Pin into position. Pass the needle through from the wrong side, through the folded edge, and into the underside. Take the needle out inserting again straight opposite through the folded edge. Continue along the folded edge for  $\frac{1}{2}$ " and repeat the procedure. On completion, turn to the wrong side and machine on the tack line.

7. Bar Tack – Permanent stitch used to strengthen parts of a garment (e.g. ends of buttonholes, pockets and pleats, holding sections of garments together—(linings, collars, etc.). Using the thread used for making the garment, pass the needle from one side of the garment to the other 3 to 4 times. The distance left between the two will depend on the function and position of the bar tack. Wind the needle thread round the threads, or cover this with a continuous buttonhole stitch to make a close firm bar.

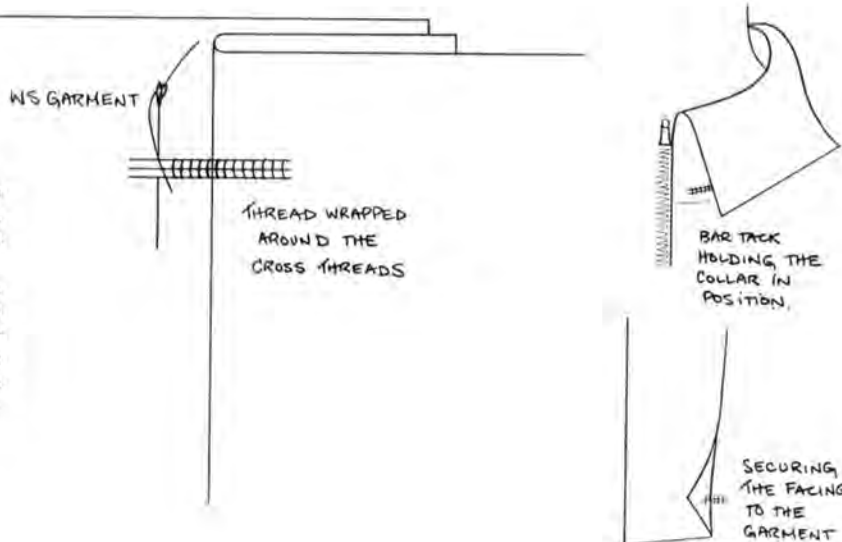

WS GARMENT

THREAD WRAPPED  
AROUND THE  
CROSS THREADS

BAR TACK  
HOLDING THE  
COLLAR IN  
POSITION

SECURING  
THE FACING  
TO THE  
GARMENT





# BUTTON AND BUTTONHOLE POSITIONS

**Centre Front Line.** The centre front of a garment divides the bodice and skirt into two equal parts. This line is usually indicated with a trace tacking. With a buttoned centre front opening an allowance or extension has to be added to the garment outside the centre front line. The extension or allowance is proportionate to the size of the buttons and also to the type of garment. For example a coat would require a much larger button and respective overlay than would a child's dress in fine fabric.

1. The diagram shows the right and left bodices crossing over and matching at the centre front. If the position of the buttonholes is not indicated on the pattern the following simple rules should help to determine the buttonholes: The top button should be at least  $\frac{1}{2}$ " away from the neck edge. The button should not extend over the edge of the garment. The extension should be at least  $\frac{1}{2}$ " width of the button plus  $\frac{1}{4}$ ". Position the top and lower buttonholes first and divide up the distance between the number of buttons.

For example:-

Centre front opening,  $17\frac{1}{2}$ ". Five 1" buttons. Top buttonhole  $\frac{3}{4}$ " from neck edge. Lower buttonhole  $\frac{3}{4}$ " from the hem. Three buttons 4" apart

With horizontal buttonholes the round end of the buttonhole is positioned on the centre front line. The buttonhole then extends inwards the length of the button. With bound buttonholes begin  $\frac{1}{8}$ " outside the centre front line. This will allow for the extra width of buttonhole required. The shank of the button (the threads holding the button in position) should pass through the round end of the buttonhole. The button will then sit equally either side of the centre front line to ensure the garment is balanced correctly holding the garment together in this way.

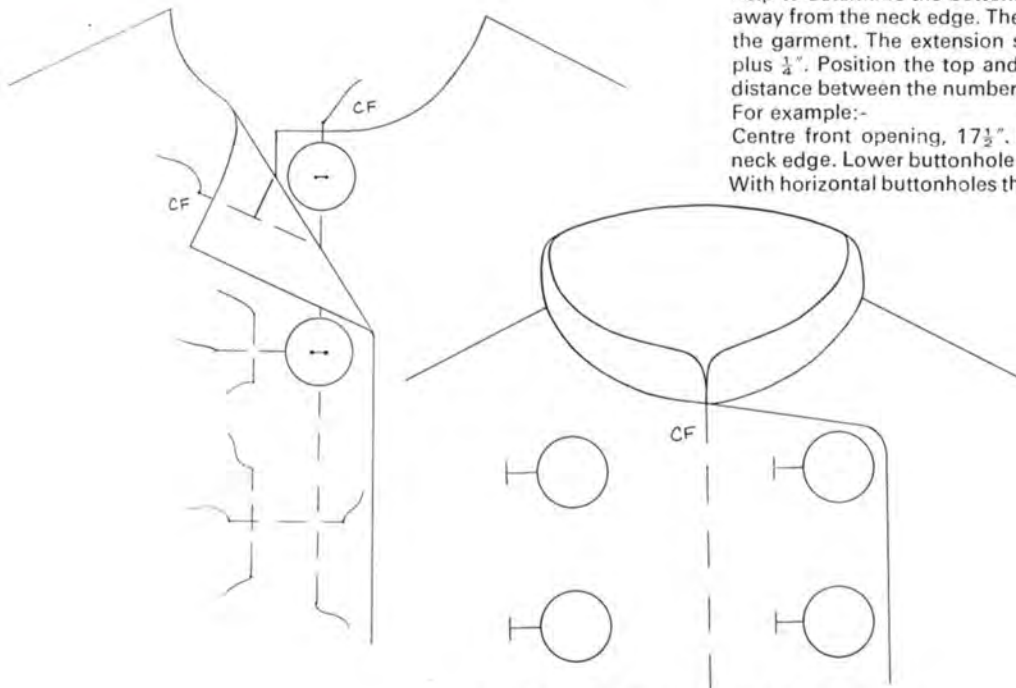

2. **Double Breasted Garment.** The buttons should sit an equal distance either side of the centre front line. Usually the outer buttonholes are the only functional ones. If both sides are to be functional the buttonholes are worked in the same direction as in the diagram. As before the outer button should not extend over the folded edge and should be positioned accordingly.

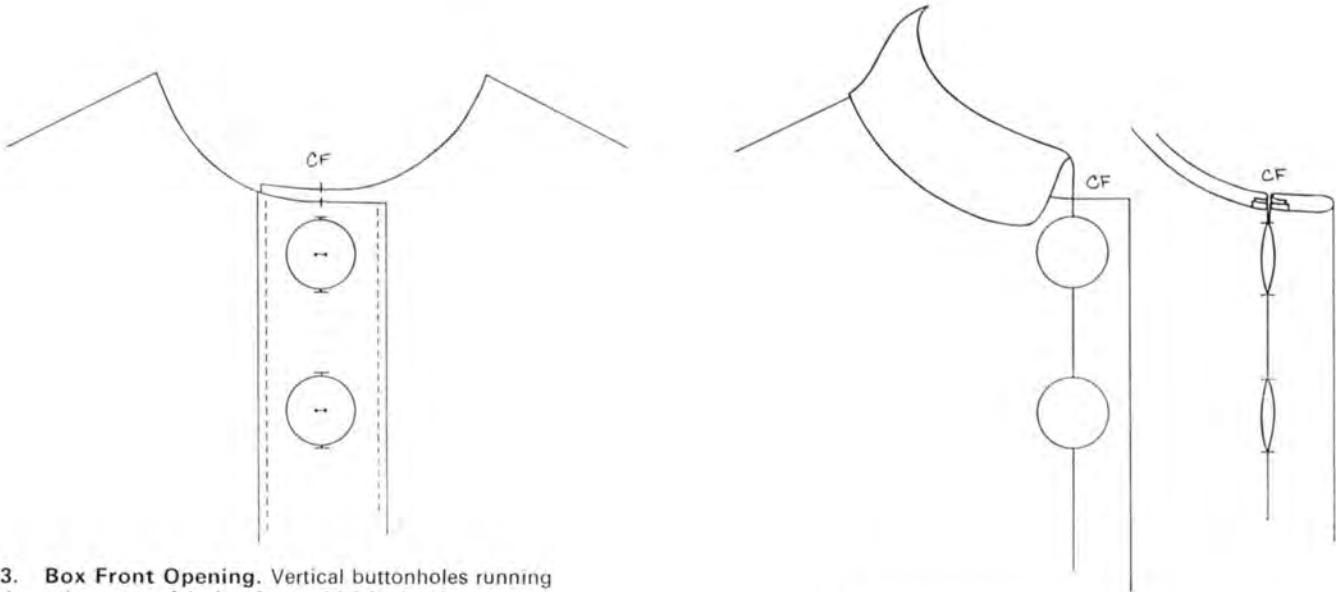

3. **Box Front Opening.** Vertical buttonholes running down the centre of the box front which is also the centre front line. The top edge of the button should lie at least  $\frac{1}{4}$ " away from the neck edge and the buttonhole will begin at this point and extend downwards with two straight ends. The button must be sewn into position so that it sits in the centre of the buttonhole.

4. **Buttonholes Inserted in a Seam.** Seam the binding or bend down the centre front line leaving the appropriate spaces for the buttonholes. Position these as previously instructed for vertical buttons. Strengthen at each end.



### 5. Fly Front Fastening.

The buttonholes are worked vertically down the centre of the undersection which is also the centre front line of the garment, except in trousers. The buttons and buttonholes are not visible from the right side and the two edges are held together between the buttons with a bar tack. Use a very flat button for a fly front.

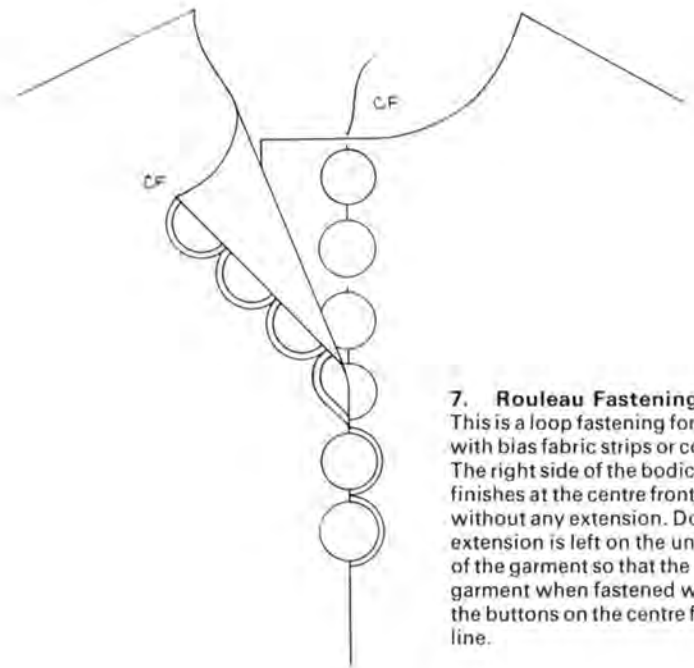
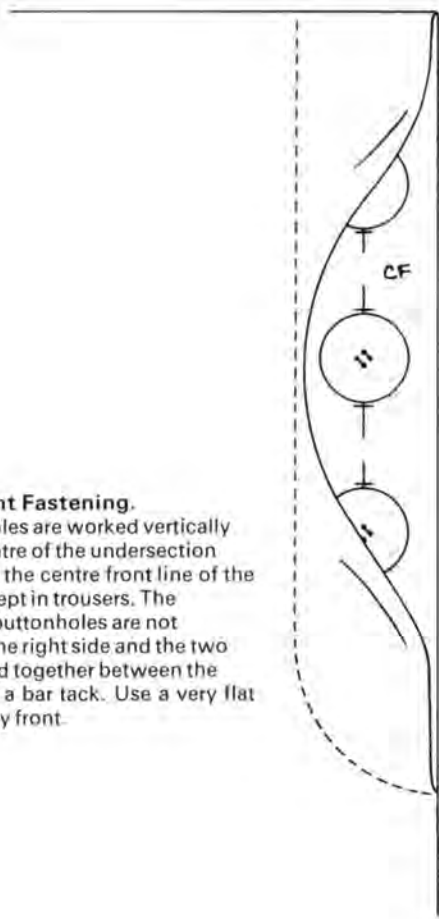

### 7. Rouleau Fastening.

This is a loop fastening formed with bias fabric strips or cord. The right side of the bodice finishes at the centre front line without any extension. Double extension is left on the underside of the garment so that the garment when fastened will have the buttons on the centre front line.

FLAT BUTTON



BUTTON HOLE

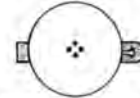

WORKED - EXACT WIDTH  
BOUND - WIDTH + 1/8"

SHANK



LONG SHANK

HIGH DOME BUTTON



PLASTIC SHANK



WIDTH + 1/8"



CLOSE STITCHING

DOME BUTTON



METAL SHANK

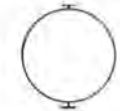

EXACT WIDTH



SMALL SHANK

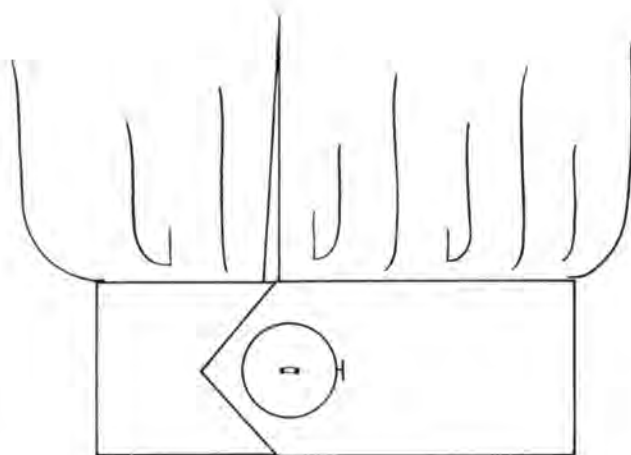

**6. Cuff Fastening.** With single button fastening position the buttonhole in the centre of the cuff running horizontally. The round end of the button stitched in position so that the shank sits in the round end of the buttonhole.

**8. Flat Button** These are plain buttons used on coats, fly front fastenings, blouses, shirts and dresses.

The buttonholes are made the exact width of the button for the worked or machine buttonholes and  $\frac{1}{8}$ " larger for bound buttonholes. Sew the button to the garment leaving a distance of threads between the button and the garment. The distance left is determined by the thickness of the fabric. A heavy coat will need a shank of about  $\frac{1}{2}$ " and a small button sewn on to the underside to add strength. Wrap the threads round the shank starting at the button end and finishing securely on the garment.

Diagram B shows the square and round end of the buttonhole. When the garment is fastened the button will move along until the shank rests in the round end of the buttonhole.

**High Dome Button** These buttons often have a plastic or metal shank already formed as part of the button. In these cases no extra length of thread is required and they can be stitched close to the garment. The width of the buttonhole is the diameter of the button plus  $\frac{1}{8}$ ". Similarly the button will move to the round end of the horizontal buttonhole.

**Dome Button** Slightly raised button with plastic, metal or cotton shank. Stitch close to the garment. Worked buttonholes the exact size of the button, bound buttonholes  $\frac{1}{8}$ " larger.





## JETTED POCKET

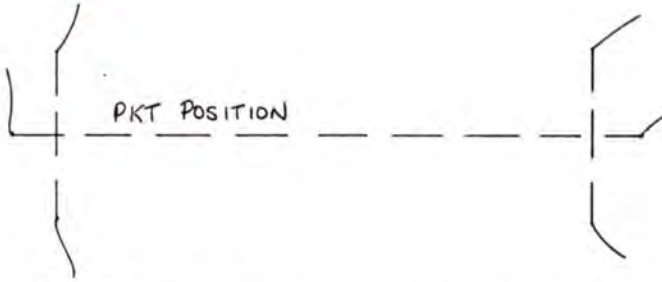

1. Mark the pocket position with trace tacking. Indicate the width of the pocket with short vertical tack lines. Strengthen the back of the pocket with a strip of iron-on interfacing.



2. Cut two jettings the length of the pocket plus 1" and 2" deep. With jersey and stretch fabrics the jersey can be cut the opposite way of the fabric with the least amount of stretch going across the jetting. This will help to prevent the pocket stretching out of shape.



3. Fold the jettings in half, right side out. Press.

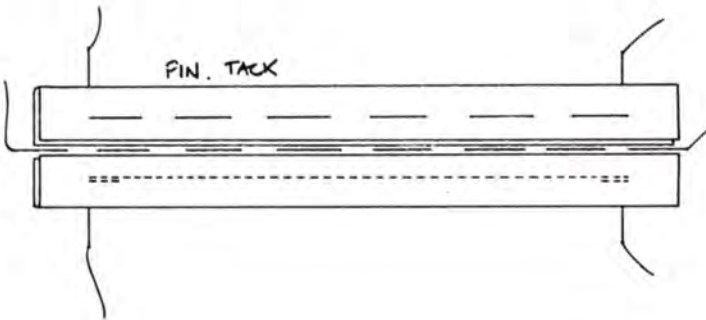

4. Place the two jettings either side of the pocket line on the right side and with the raw edges meeting in the centre, pin into position and tack down the centre of the jettings.

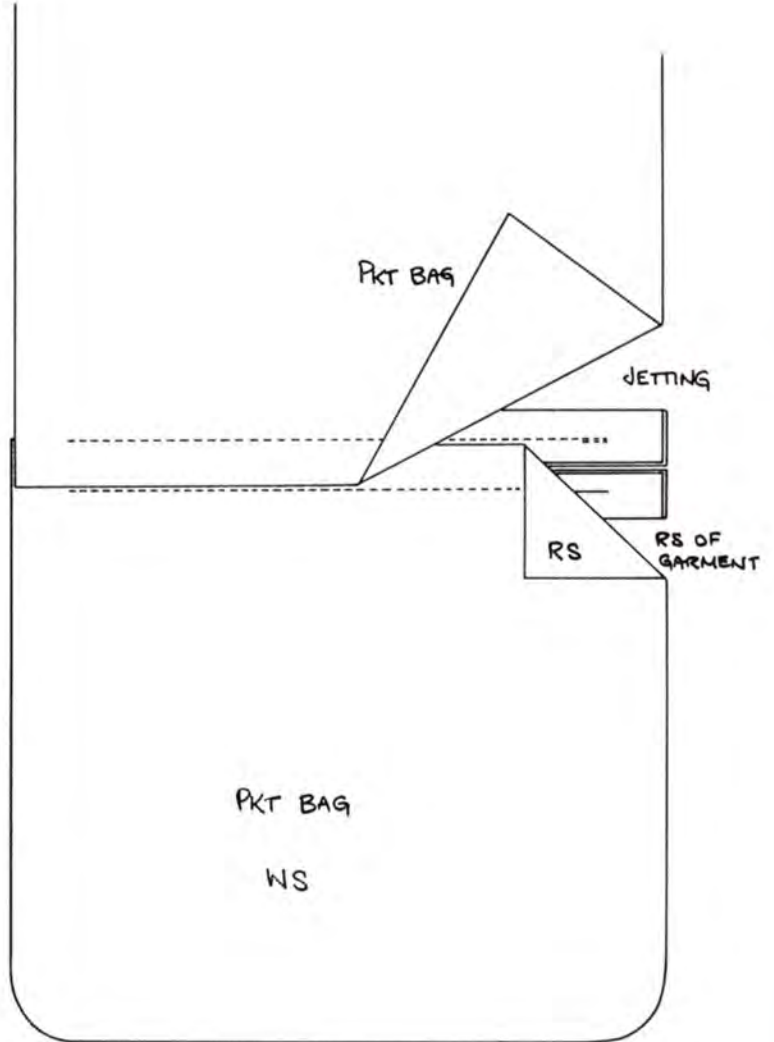

5. Cut the pocket bag in one piece or two sections. Place the pocket bag over the jettings on the right side, overlapping as in the diagram if it is cut in two sections. Machine through the centre of the jettings taking care to keep them parallel to each other and reverse stitch at each end.



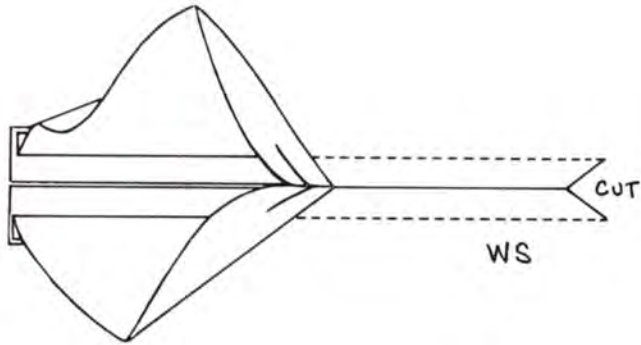

6. From the wrong side cut through the garment down the centre of the machining and into each corner. Draw the pocket bag through to the wrong side.

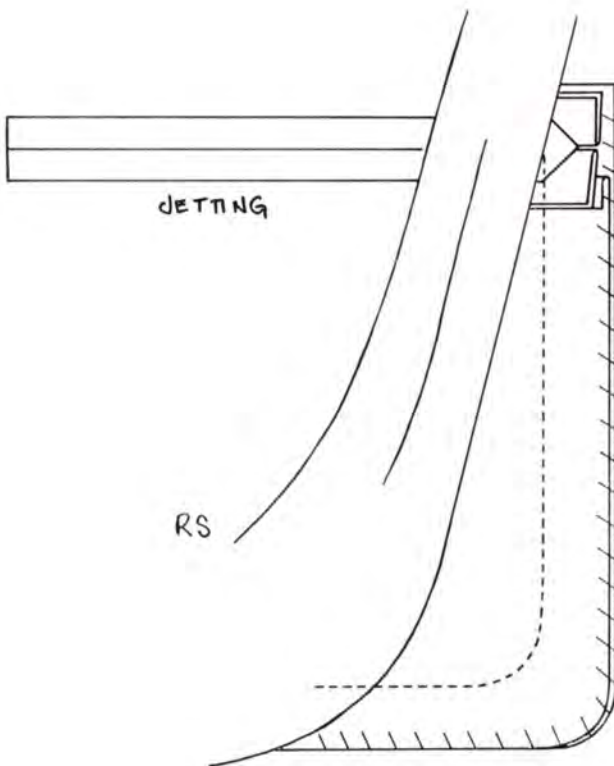

7. Turn to the right side and press. Fold back the garment. Machine across the V section at the corner of the pocket and down round the pocket bag. Overlock round the outer edge to prevent fraying.

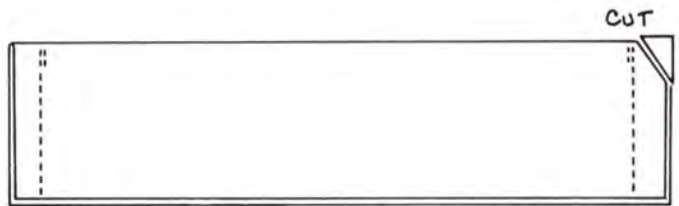

1.A. Cut the welt the length of the pocket plus  $\frac{1}{2}$ " and twice the depth of the welt plus  $\frac{1}{2}$ ". Interface on the underside with a fusible fabric to stiffen. Fold right sides facing. Machine  $\frac{1}{4}$ " seams down each side. Trim the interfacing away to the machining. Cut across the corner. Turn through. Press.

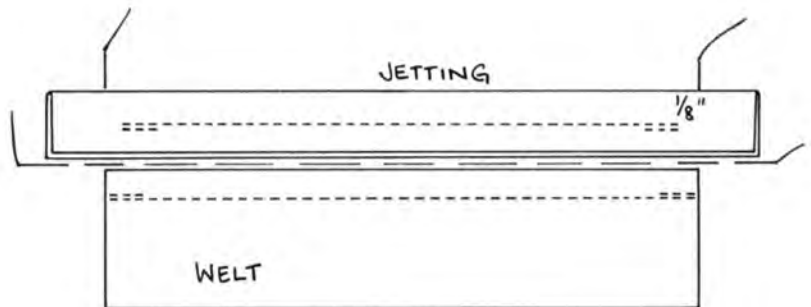

2.A. Prepare the jetting as in the jetted pocket and mark the position of the pocket. Place the welt below this line with the raw edge uppermost. Position the jetting above the tack line. Pin tack through the centre of the jetting to within  $\frac{1}{8}$ " of either end of the pocket. Pin and tack the welt  $\frac{1}{4}$  -  $\frac{3}{8}$ " away from the pocket line. Proceed as for diagram 5 in Jetted Pocket by machining the pocket bag on to these sections.

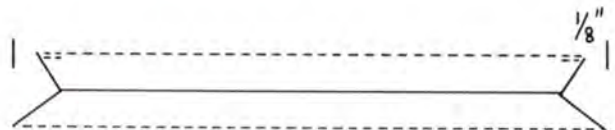

3.A. From the wrong side cut through the machining into the corners, the lower one longer than the top one as indicated in the diagram. This reduced width of machining on the top jetting then produces a neater finish to the edges of the welt from the right side. Proceed as for diagram 6 Jetted Pocket. Proceed as for diagram 7 Jetted Pocket.

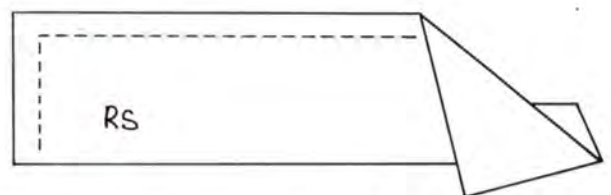

4.A. Press the welt upwards. Secure the sides either by a prick stitch by hand or machine stitching.



# teenagers shortie sweater

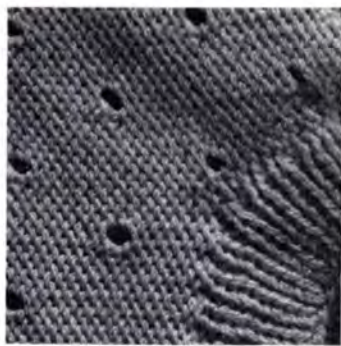

## Materials

11 (12, 13, 14) oz. Emu Double Crepe.

## Measurements

To fit bust sizes 32 (34, 36, 38) ins.

Actual bust measurements 32 (34, 36, 38) ins.

Length from top of raglan 17 (17½, 18, 18½) ins.

Sleeve seam 7 ins.

## Tension

12 sts. and 17 rows to 2 ins. over pattern.

## Abbreviations

sts., stitches; inc., increase; dec., decrease; foll., following; alt., alternate; beg., beginning; T., tension; 000, return row counter to 000.

## Notes

Figures in brackets refer to larger sizes respectively. Fully fashioning decreasing on raglan edges is worked by transferring 2nd st. onto 3rd needle and moving the end st. 1 needle in. This garment is made up on the purl side, but can be reversed if preferred.

## BACK

**Ribbers:** Cast on 98 (106, 110, 118) sts. for 2 x 2 rib. T8/8. Knit 35 rows. Transfer all sts to main bed.

**Hand rib:** Using No. 10 knitting needles cast on 98 (100, 110, 118) sts. Work 4½ ins. in k.2 p.2 rib. Transfer sts. to machine.

**All machines:** 000. T10. Following pattern chart knit 34 rows.

## Shape Raglan Armholes

000. Cast off 2 sts. at beg. of next 2 rows. Knit 2 rows. Dec. 1 st. (see notes) at each end of next and every foll. 4th row 3 (2, 4, 3) times in all, then every foll. alt. row until 30 (32, 34, 36) sts. remain. Knit 1 row. Slip sts. onto a knitting needle.

## FRONT

Work as Back until 52 (54, 56, 58) sts. remain after beg. of raglan shaping. Knit 1 row.

## Shape Neck

Slip 34 (36, 38, 40) sts. at left of machine onto a knitting needle. Work on remaining 18 sts. Continue raglan shaping as before, at the same time knit 2 rows. Dec. 1 st. at neck edge on next and foll. 4th row until 3 sts. remain. Knit 1 row. Dec. 1 st. at raglan edge on next row. Cast off 2 sts. Replace 18 sts. from left side of knitting needle onto machine. Join wool at centre. Knit as right side reversing all shapings.

## SLEEVES

**Ribbers:** Cast on 66 (70, 74, 78) sts. for 2 x 2 rib. T8/8. Knit 23 rows. Transfer all sts. to mainbed.

**Hand rib:** Using No. 10 knitting needles cast on 66 (70, 74, 78) sts. Work 3 ins. in k.2 p.2 rib. Transfer sts. to machine.

## All machines

000. T10. Following chart, knit 6 rows. Inc. 1 st. at each end of next and every foll. 6th row until there are 74 (78, 82, 86) sts. Knit straight until 34 rows have been worked.

## Shape Raglan Armholes

000. Cast off 2 sts. at beg. of next 2 rows. Knit 2 rows. Dec. 1 st. at each end of next and every foll. 4th row 5 (5, 7, 7) times in all, then every alt. row until 10 (10, 12, 12) sts. remain. Knit 1 row. Slip sts. onto a knitting needle.

## NECKBAND

With knit side facing place on machine

30 (32, 34, 36) sts. from back neck, 10 (10, 12, 12) sts. from 1st sleeve, 19 sts. down front, 16 (18, 20, 22) across centre 19 sts. up front, 10 (10, 12, 12) sts. from 2nd sleeve. 104 (108, 116, 120) sts. Knit 1 row. Transfer alt. sts. to ribber. T8/8, knit 10 rows. Cast off loosely.

**Hand rib:** Pick up stitches as given for ribbers, on No. 10 knitting needles. Work 1 in. in k.1 p.1 rib. Cast off loosely.

## To Make Up

Pin out and press with a hot iron over a damp cloth. Sew raglan, side and sleeve seams. Press seams.

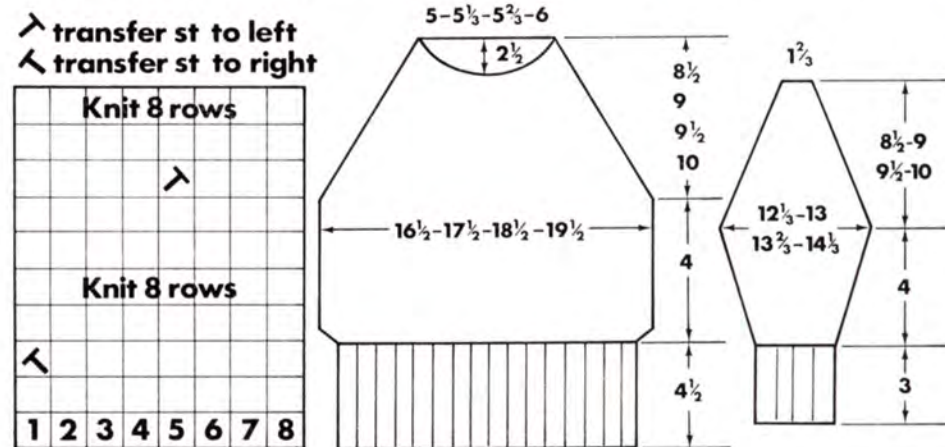



# babys dress coat and bootees

## Materials

**Dress:** 3 (3, 4) ozs. Listers Lavenda 3-ply, 4 buttons, crochet hook.

**Coat:** 3 (3, 4) ozs. Lavenda 3-ply, 1 yd. narrow ribbon crochet hook.

**Bootees:** 1 oz. Lavenda 3-ply, 1 yd. narrow ribbon.

## Measurements

To fit chest sizes 18 (20, 22) ins.

**Dress:** Finished measurement at chest 19 (21, 23) ins.

Length at back neck 13 (13½, 14) ins.

Sleeve seam 1½ ins.

**Coat:** Finished measurement at chest 19½ (21½, 23½) ins.

Length at back neck 10 (10½, 11) ins.

Sleeve seam 5 (5½, 6) ins.

**Bootees:** Length of foot 3 (3½, 3¾) ins.

## Tension

Pattern stitch 15 sts. and 34 rows to 2 ins.

Stocking-stitch 18½ sts. and 24 rows to 2 ins.

## Abbreviations

K., knit; sts., stitches; inc., increase; dec., decrease; rep., repeat; alt., alternate; foll., following; beg., beginning; tog., together; T., tension; 000, set row counter at 000.

## DRESS

### Front

Cast on 83 (91, 99) sts. T4. K. 2 rows. HCL's III. Push every 4th needle to E position. K. 5 rows. HCL's I. K. 2 rows. Make a hem and knit the row. 000. T4. Foll. chart, k. 20 rows. Dec. 1 st. at each end of next and every foll. 26th row until 73 (81, 89) sts. remain. K. straight until 148 (152, 156) rows have been worked. \* (Adjust length here if required).

### Shape Armholes

000. Cast off 2 (3, 4) sts. at beg. of next 2 rows. Dec. 1 st. at each end of next and every foll. alt. rows until 57 (63, 69) sts. remain. K. straight until 52 (56, 60) rows have been worked.

### Divide for neck

Using odd length of wool cast off centre 11 (13, 15) sts. Slip sts. at left on to a

knitting needle. Knit the right side first. K. 1 row. Dec. 1 st. at neck edge on next and every foll. alt. row until 18 (20, 22) sts. remain. 62 (66, 70) rows have been worked. (Knit 1 row for left side).

### Shape shoulder

Cast off 5 sts. at beg. of next and alt. rows until 3 (5, 7) sts. remain. K. 1 row. Cast off. Replace sts. on machine. Knit to match right side reversing all shapings.

## BACK

Knit as Front to \*.

### Divide for opening

Transfer centre st. on to needle at right. Slip sts. at left on to a knitting needle. Knit the right side first. 36 (40, 44) sts.

### Shape Armhole

\* 000. Cast off 2 (3, 4) sts. at beg. of next row. K. 1 row. Dec. 1 st. at beg. of next and every foll. alt. rows until 28 (31, 34) sts. remain. K. straight until 62 (66, 70) rows have been worked.

### Shape Shoulder

Cast off 5 sts. at beg. of next and alt. rows 3 times in all then 3 (5, 7) sts. on foll. alt. row. K. 1 row. Cast off remaining 10 (11, 12) sts. Replace sts. on machine. Join wool at centre and k. 1 row. Knit as right side from \* to end.

## SLEEVES

Cast on 49 (53, 57) sts. T4. K. 2 rows. HCL's III. Push 3rd and every foll. 4th needle to E position. K. 5 rows. HCL's I. K. 2 rows. Make a hem and k. the row. 000. T4. Foll. chart, k. 4 rows. Inc. 1 st. at each end of next and every foll. 4th row until there are 55 (59, 63) sts. K. 3 rows.

### Shape Armholes

Cast off 2 (3, 4) sts. at beg. of next 2 rows. Dec. 1 st. at each end of next and every foll. alt. rows 6 (7, 8) times in all, then every foll. 4th row until 29 sts. remain. K. 1 row. Dec. 1 st. at each end of next 7 rows. Cast off remaining 15 sts.

### To Make Up

Pin out and press with a hot iron over a damp cloth. Join side, shoulder and sleeve seams. Sew in sleeves. Work 2 rows of double crochet round back opening and round neck, making 4 loops on one side of opening. Break wool. Work 1 row of shell pattern round neck. Sew on buttons. Press seams.

## COAT

### Back

Cast on 85 (93, 101) sts. T4. K. 2 rows. HCL's III. Push 3rd every foll. 4th needle to E position. K. 5 rows. HCL's I. K. 2 rows. Make a hem and knit the row. 000. T4. Foll. chart K. 10 rows. Dec. 1 st. at each end of next and every foll. 18th row until there are 75 (83, 91) sts. K. straight until 98 (102, 106) rows have been worked. Adjust length here if required.

### Shape armholes

000. Cast off 2 (3, 4) sts. at beg. of next 2 rows. Dec. 1 st. at each end of next and every foll. alt. row until 59 (65, 71) sts. remain. K. straight until 64 (68, 72) rows have been worked.

### Shape shoulders

Cast off 5 sts. at beg. of next 6 rows and 4 (6, 8) sts. on next 2 rows. Cast off remaining 21 (23, 25) sts.

### Left Front

Cast on 42 (46, 50) sts. T4. K. 2 rows. HCL's III. Push 3rd and every foll. 4th needle to E position. K. 5 rows. HCL's I. K. 2 rows. Make a hem and knit. 000.

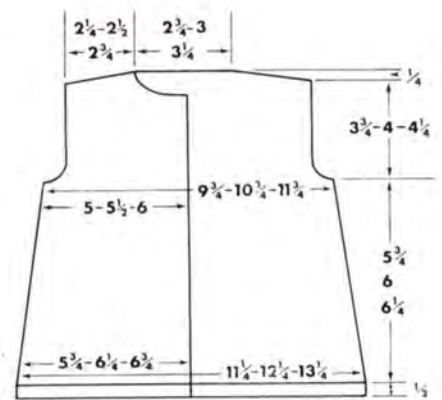

COAT

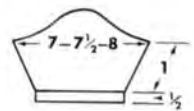
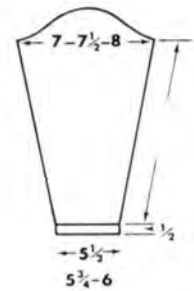

DRESS

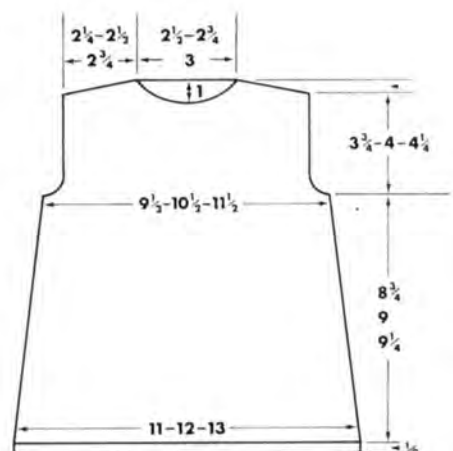















# girls pinafore dress

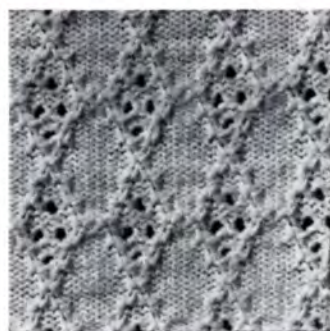
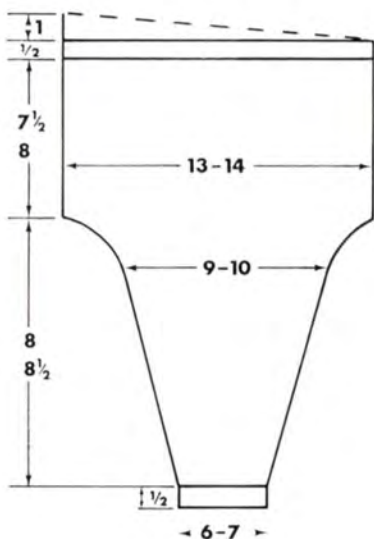
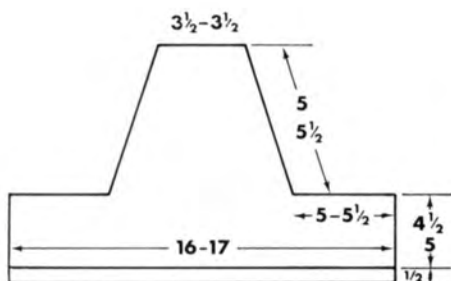
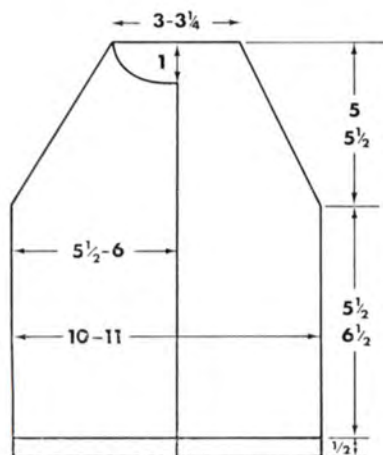
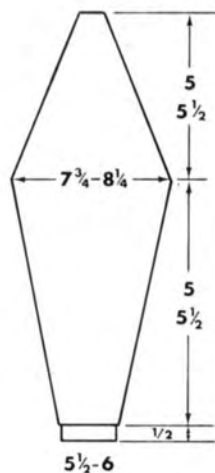

**Materials** 8 (9, 10, 11)  $\frac{1}{4}$  oz. balls Robin Bri-Nylon 3 ply. 2 Buckles.

## Measurements

To fit a 26 (28, 30, 32) inch bust; finished measurements 28 (30, 32, 34) ins; length to top of shoulder 25 (26 $\frac{1}{2}$ , 29, 31) ins. approx.

**Tension** 14 sts. and 32 rows to 2 ins. measured over pattern.

## Abbreviations

Sts., stitch(es); alt., alternate; rep., repeat; foll., following; inc., increase; dec., decrease; beg., beginning; T., tension; 000, return Row Counter to 000.

## Back

Cast on 113 (119, 127, 133) sts. by hand having the odd st. on right side of work.

T.6. Knit 12 rows. 000. Change to T.7. and following chart, knit 30 rows. Dec. 1st at both ends of next and every foll. 42nd (44th, 48th, 52nd) row until there are 99 (105, 113, 119) sts. Knit straight until 304 (328, 352, 376) rows have been worked. (This will give a finished length of 19 (20 $\frac{1}{2}$ , 22, 23 $\frac{1}{2}$ ) ins. to armhole. Adjust length here if required).

## Shape Armholes

000. Cast off 4 (5, 6, 7) sts. at beg. of next 2 rows. \* Dec. 1 st. at both ends of next and every foll. alt. row 5 times in all and then every foll. 4th row until 71 (75, 79, 82) sts. remain. Knit straight until 36 rows have been worked.









cable as on Front. 000. T7. Knit 6 rows. Inc. 1 st. each end of next and foll. 6th (8th) row until there are 47 (51) sts. Knit straight until 44 (54) rows have been worked.

#### Shape Raglan Armholes

000. Cast off 5 sts. at beg. of next 2 rows. Knit 2 rows. Dec. 1 st. (see notes) at each end of next and every foll. 4th row 4 times in all and then on every foll. alt. row until 11 sts. remain. Knit 1 row. Slip sts. on to a knitting needle.

#### Neckband

With wrong side facing pick up and place on machine 23 (27) sts. from back neck, 11 sts. from sleeve, 10 (11) down front neck, 11 (13) sts. from centre front, 10 (11) sts. up front neck, 11 sts. from sleeve. 76 (84) sts. Knit 1 row.

**Ribbers:** Transfer alt. sts. to ribber. T4/4. Knit 16 rows. Cast off loosely.

**Single machines:** Transfer alt. sts. on to adjacent needles and push empty needles to A position. T4. Knit 16 rows. Cast off making a chain over empty needles.

#### To Make Up

Pin out and press with a hot iron over a damp cloth. Join side, sleeve and raglan seams. Turn neckband to wrong side and slip-stitch in place. Press seams. If a neck opening is desired, leave an opening of 2 ins. on left back raglan seam. Sew on 3 buttons and crochet loops on opposite side to match.

#### PANTS - BACK

**Ribbers:** Cast on 67 (73) sts. for 1 x 1 rib. T4/4. Knit 16 rows. Transfer sts. to M.B. for stocking-stitch.\*

**Single machines:** Cast on 34 (37) sts. over alt. needles. T4. Knit 15 rows. Make a hem and knit the row. 67 (73) sts.\*

#### All machines - Shape Back

000. T7. HCL's II. Always winding wool round first needle in E position. Push 5 (6) sts. at opposite end to carriage to E position on next 8 rows. Push all needles at opposite end to carriage to C position on next 2 rows. Knit straight until 54 (62) rows have been worked.

#### Leg Shaping

000. Cast off 2 sts. at beg. of next 24 (26) rows. 19 (21) sts. remain. Knit 4 rows. Slip-sts. on to knitting needle.

#### Front

Work as back to \*. 000. T7. Knit 44 (52) rows.

#### Leg Shaping

000. Cast off 8 sts. at beg. of next 2 rows. Cast off 2 sts. at beg. of next 16 (18) rows. 19 (21) sts. remain. Knit 10 rows. Slip sts. on to a knitting needle. Replace the two sets of sts. on machine together and cast off.

#### Legbands

With wrong side facing pick up and place on machine 64 (72) sts. from round leg opening. Knit 1 row.

**Ribbers:** Transfer alt. sts. to ribber. T4/4. Knit 16 rows. Cast off loosely.

**Single machines:** Transfer alt. sts. on to adjacent needles and push empty needles to A position. T4. Knit 16 rows. Cast off making a chain over empty needles. Knit second legband to match.

#### To Make Up

Pin out and press with a hot iron over a damp cloth. Join side seams. Turn leg bands to wrong side and slip stitch in place. Slip stitch waistband in place inserting elastic to fit waist.

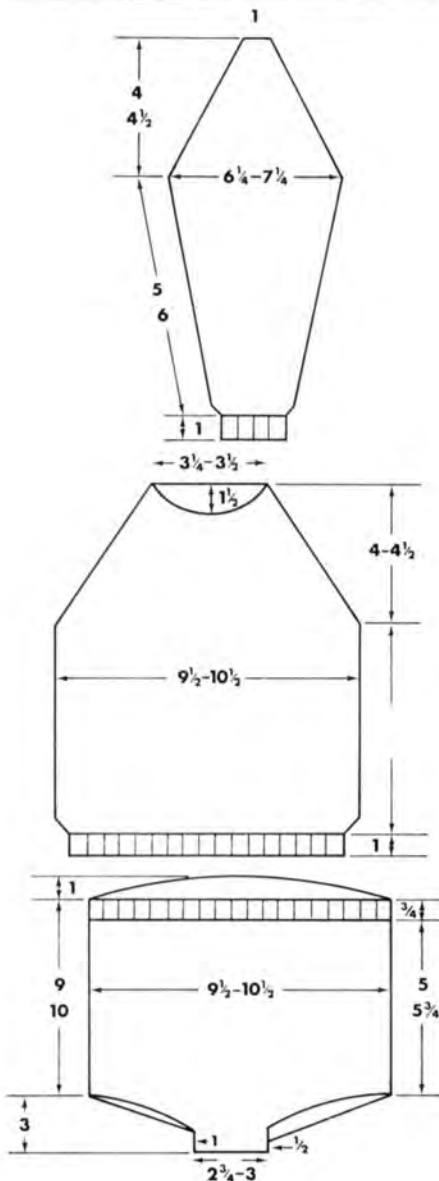

edge on next and every alt. row until 4 sts. remain. Continue dec. on raglan edge only until 2 sts. remain, knit 1 row. Cast off. HCL's I. Rejoin wool at neck edge and knit to match right side reversing all shapings.

#### SLEEVES

**Ribbers:** Cast on 35 (39) sts. as for 1 x 1 rib. T4/4. Knit 10 rows. Transfer all sts. to M.B. for stocking-stitch.

**Single machines:** Cast on 18 (20) sts. over alt. needles. T4. Knit 19 rows. Make a hem and knit the row. 35 (39) sts.

**All machines:** Arrange centre 11 needles for













row extra for boys version.

Slip 27 (31) sts. at opposite end to Carriage on to a knitting needle. Knit on remaining 34 (38) sts. K. 1 row in st.-st. Cast on 6 sts. at beg. of next row. Keeping 12 sts. at front edge in st.-st. continue in lace pattern for 4 (6) rows. Counting from front edge make a buttonhole over needles 3 and 4, and 9 and 10 on next row and every foll. 15th (16th) row 3 times in all *at the same time*, knit until 16 (18) rows have been worked.

#### Shape Armholes

000. Cast off 2 (3) sts. at beg. of next row. K. 1 row. Dec. 1 st. at beg. of next and every foll. alt. row until 34 (37) sts. remain. Knit straight until 31 (33) rows have been worked.

#### Shape neck

Cast off 13 (14) sts. at beg. of next row. K. 1 row. Dec. 1 st. at neck edge on next 5 rows and foll. alt. rows twice 14 (16) sts.

#### Shape Shoulder

Cast off 5 sts. at beg. of next and foll. alt. row. K. 1 row. Cast off remaining 4 (6) sts.

Replace sts. on to machine. Join wool at centre. 000. T7. K. 2 rows. in st.-st. Cast on 12 sts. at beg. of next row. Keeping 12 sts. at front edge in st.-st. but omitting buttonholes, continue in lace pattern until 17 (19) rows have been worked.

#### Shape Armhole

Cast off 2 (3) sts. at beg. of next row. K. 1 row. Dec. 1 st. at armhole edge on next and every foll. alt. rows until 27 (30) sts. remain. Knit straight until 32 (34) rows have been worked.

#### Shape Neck

Cast off 12 (13) sts. at beg. of next row. K. 1 row. Dec. 1 st. at neck edge on next 5 rows and every foll. alt. rows twice.

#### Shape Shoulder

Cast off 5 sts. at beg. of next and foll. alt. row. K. 1 row. Cast off remaining 4 (6) sts.

### SLEEVES

Using contrast wool cast on 53 (57) sts. Knit a few rows. Change to main wool 000. T7. K. 2 rows. Continue in lace pattern and K. 8 rows.

#### Shape Top

Cast off 2 (3) sts. at beg. of next 2 rows. Dec. 1 st. at both ends of next and every foll. alt. rows until 29 sts. remain. K. 1 row. Cast off 2 sts. at beg. of next 2 rows, and 3 sts. at beg. of next 4 rows. Cast off remaining 13 sts.

### SLEEVE RIB

Push 39 (43) needles to B position. Unravel contrast wool and transfer loops to machine, dec. 14 sts. evenly along row. K. 1 row.

**Ribbers:** Transfer alt. sts. to ribber. T3/3. Knit 6 rows. K. 1 loose row. Transfer sts. to main bed and cast off using chain method.

**Single machines:** T6. K. 14 rows. K. 1 loose row. Cast off using chain method. Alt. K. 6 rows in k.1, p.1 rib on No. 11 needles. Cast off.

### Neckband

Fold front facings in for 6 sts. and slip-st. in place. Join shoulder seams. With wrong side facing pick up and place on machine 16 sts. from 1 front neck, 19 (21) sts. from back neck and 17 sts. from other front neck. 53 (55) sts. K. 1 row.



**Ribbers:** Transfer alt. sts. to ribber. T3/3. \* K. 3 rows. Make a buttonhole over needles 3 and 4 from front edge. K. 3 rows.\* Knit 1 loose row. Transfer sts. to main bed and cast off using chain method.

**Single machines:** T6. K. 3 rows. Make a buttonhole over needles 3 and 4 from front edge. K. 6 rows. Make a buttonhole as before. K. 3 rows. K. 1 loose row. Cast off using chain method. Alternatively, pick up sts. round neck with No. 11 needles and knit as given for Ribbers from \* to \*. Cast off.

### Leg Bands

Join side seams. With wrong side facing, pick up and place on machine 90 (100) sts. from round leg. K. 1 row.

**Ribbers:** Transfer alt. sts. to ribber. T3/3. \* K. 4 rows. Make a buttonhole on back half

of leg by transferring 4th st. on to 5th needle. K. 8 rows. Make a buttonhole as before. K. 4 rows. K. 1 loose row. Transfer sts. to main bed. Cast off using chain method.

**Single machines:** T6. K. 4 rows. Make a buttonhole on back half of leg by transferring 4th st. on to 5th needle. K. 8 rows. Make buttonhole as before. K. 4 rows. K. 1 loose row. Cast off, using chain method. Alternatively pickup sts. with No. 11 needles and knit as Ribbers from \* to \*. Cast off.

### To Make Up

Pin out and press with a cool iron over a dry cloth. Join sleeve seams. Set in sleeves. For single machines turn neck, sleeve and leg bands to wrong side and slip-stitch in place. Sew cast on edges of front facings to top of waist ribbing. Neaten buttonholes and sew on buttons. Press seams.





# toddlers cross-over cardigan

## WITH CABLE BORDER

### Materials

3 (4, 4, 5) ozs. Paton and Baldwins Purple Heather 4-ply. 4 buttons. A pair No. 11 knitting needles; crochet hook.

### Measurements

To fit chest sizes 20 (22, 24, 26) ins.  
Actual measurements 21 (23, 25, 27) ins.  
Length at centre back 9½ (10, 10½, 11) ins.  
Sleeve seam 7 (8½, 10, 11½) ins.

### Tension

14½ sts. and 20 rows to 2 ins. after pressing.

### Abbreviations

Sts., stitches; inc., increase; dec., decrease; alt., alternate; beg., beginning; T., tension; 000, set row counter at 000.

### Cable Pattern

Cross sts. 3 and 4 *over* 1 and 2. Cross sts. 5 and 6 *over* 7 and 8. Knit 6 rows. Repeat.

### Notes

Decreasing at front edge is worked before arranging sts. for cable pattern. Decrease on 1st st. after needle in A position (11th st.) and move the 10 end sts. 1 needle in (always having 1 needle each side of cable in A position as given).

### BACK

**Ribbers.** Cast on 77 (85, 93, 101) sts. as 1 × 1 rib. T3/3. Knit 10 rows. Transfer sts. to main bed.

**Hand rib.** With No. 11 needles cast on 77 (85, 93, 101) sts. Knit 10 rows in k.1 p.l. rib. Transfer sts. to machine. 000. T7. Knit straight for 44 (46, 48, 50) rows.

### Shape armholes

000. Cast off 3 (4, 4, 5) sts. at beg. of next 2 rows. Dec 1 st. at each end of next 3 rows then every following alt. row until 59 (65, 71, 77) sts. remain. Knit straight until 44 (46, 48, 50) rows have been worked.

### Shape shoulders

Cast off 6 (6, 7, 7) sts. at beg. of next 4 rows and 5 (7, 7, 9) sts. at beg. of next 2 rows. Cast of remaining 25 (27, 29, 31) sts.

### RIGHT FRONT

**Ribbers.** Cast on 55 (59, 63, 67) sts. as 1 × 1 rib. T3/3. Knit 5 rows. Make a buttonhole over needle 17 (21, 25, 29) from right side. Knit 5 rows. Transfer sts. to main bed.

**Hand rib.** With No. 11 needles cast on 55 (59, 63, 67) sts. Work in k.1 p.l. for 4 rows. *Next row:* Rib 16 (20, 24, 28) sts., cast off 2 sts., rib to end. *Next row:* Rib, casting on 2 sts. over holes on previous row. Work in rib for 4 rows. Transfer sts. to machine.

000. T7. Counting from left transfer 3rd and following 9th sts. on to adjacent needle. Push empty needle to A position. Knit 2 rows. Dec. 1 st. (see notes) at front edge (left side) on next and every following 3rd row, *at the same time* make another buttonhole over same needle as before. Knit 3 rows. Work cable pattern. Continue until 44 (46, 48, 50) rows have been worked. (Knit 1 extra row for Left Front.)

### Shape armhole

000. Continuing front shaping and cable pattern cast off 3 (4, 4, 5) sts. at beg. of next row. Knit 1 row. Dec. 1 st. at armhole edge on next 3 rows then every following alt. row 3 (3, 4, 4) times. Keeping armhole edge straight, continue neck shaping until 17 (19, 21, 23) sts. remain. Knit straight until 44 (46, 48, 50) rows have been worked.

### Shape shoulder

Cast off 6 (6, 7, 7) sts. at beg. of next and alt. rows (making a chain over empty needle and counting the empty needle as one st) until 5 (7, 7, 9) sts. remain. Knit

1 row. Cast off.

### LEFT FRONT

Knit as Right Front, omitting the buttonholes.

### SLEEVES

**Ribbers.** Cast on 41 (45, 49, 53) sts. as 1 × 1 rib. T3/3. Knit 10 (10, 14, 14) rows. Transfer sts. to main bed.

**Hand rib.** With No. 11 needles cast on 41 (45, 49, 53) sts. Work 10 (10, 14, 14) rows in k.1 p.l. rib. Transfer sts. to machine. 000. T7. Knit 10 rows. Inc. 1 st at each end of next and every following 6th (6th, 8th, 8th) row until there are 57 (63, 69, 75) sts. Knit straight until 60 (76, 86, 100) rows have been worked. This will give a sleeve seam of 7 (8½, 10, 11½) ins. Adjust length here if required.

### Shape top

Cast off 3 (4, 4, 5) sts. at beg. of next 2 rows. Dec. 1 st. at each end of next 3 (3, 5, 5) rows then every alt. row until 29 (31, 33, 35) sts. remain. Knit 1 row. Cast off 3 sts. at beg. of next 6 rows. Cast of remaining 11 (13, 15, 17) sts.

### FRONT BAND

Mark position on Right Front for 2 buttonholes to match the two already knitted.

Work 1 row of crochet up front making 2 loops to match markers across back neck gathering in slightly and down other front. Work 2 more rows.

### To make up

Pin out and press with a hot iron over a damp cloth. Join side, shoulder and sleeve seams. Sew in sleeves. Sew on buttons. Press seams.



# baby's vest and pilch



## Materials

**Vest:** 2 (2) ozs. Paton's Beehive Baby wool 3-ply. Small amount of contrast wool for crochet edging,  $\frac{3}{4}$  yd. narrow baby ribbon, crochet hook, shirring elastic.

**Pilch:** 2 (2) oz. Paton's Beehive Baby wool 3-ply. Narrow elastic to fit waist, shirring elastic.

## Measurements

**Vest:** to fit chest 16 (18) ins. Length to top of shoulder  $8\frac{1}{2}$  ( $9\frac{1}{2}$ ) ins.

**Pilch:** Garment measures 20 (22) ins. all round seat. Length at centre front 8 (9) ins.

## Tension

19 sts. and 21 rows to 2 ins. after pressing.

## Abbreviations

Sts., stitches; inc., increase; dec., decrease; M.B., main bed; T., tension; 000, set row counter to 000.

## VEST

**Ribbers:** Cast on 79 (91) sts. as for 1 x 1 rib. Knit 1 circular row. Transfer alt. sts. to M.B. and arrange for 3 x 1 rib as follows:  
M.B. 111.111.111.111.111  
Ribber .1...1...1...1.....

000. T3/1. Knit 60 (68) rows. Transfer ribber sts. to M.B. for stocking-st.

## Single Bed Machines

000. T4. Cast on 79 (91) sts. by hand. Knit 1 row. Transfer every 4th st. to adjacent needle and return empty needles to A position. Knit until 60 (68) rows have been worked. Bring empty needles to B position. Pick up loop from adjacent st. and place on empty needles.

## All Machines

### Shape Sleeves

000. T4. Cast on 6 sts. at beg. of next 2 rows. 91 (103) sts. Knit until 12 (14) rows have been worked.

### Shape neck

H.C.L.'s II. Push 66 (75) needles at left to E position. Knit right side first. 25 (28) sts. Knit 22 rows. Push needles to E position. With an odd length of wool cast off 41 (47) centre sts. Return 25 (28) needles at left of machine to C position. Starting at centre knit 22 rows. Break wool leaving a long end to cast on by hand over the centre 41 (47) empty needles. 91 (103) sts. Carriage at right. H.C.L.'s I. Knit 24 (26) rows.

### Shape Sleeves

Cast off 6 sts. at beg. of next 2 rows.

### Ribbers

Arrange needles for 3 x 1 rib. 000. T3/1. Knit 60 (68) rows. Cast off.

### Single Machines

Transfer every 4th st. to adjacent needle, and return empty needles to A position. 000. T4. Knit 60 (68) rows. Cast off making chain over empty needles.

### To Make Up

Pin out and press with a hot iron over a damp cloth. Sew side seams. Using contrast wool and crochet hook, work 1 row of double crochet and a row of shell pattern

round neck and sleeves. Press seams. Thread ribbon through holes at neck. Thread shirring elastic round sleeve edge.

## PILCH

### To Knit

**Ribbers.** Cast on 95 (105) sts. for 1 x 1 rib. 000. T2/2. Knit 6 rows. Counting from right make a row of holes by transferring the 6th (5th) and every foll. 6th st. on to adjacent needle all along the row. Knit 6 rows. Transfer sts. from Ribber to M.B. for stocking st.

### Single Bed Machines

Cast on 95 (105) sts. by hand. 000. T3. Knit 24 rows.



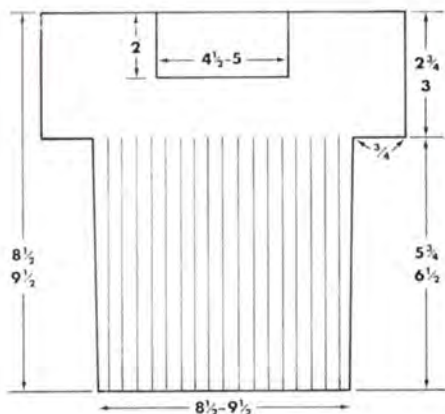

**VEST**

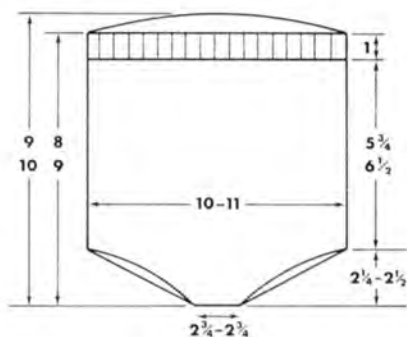

**PILCH**

**All Machines**

**Shape Back**

000. T4. H.C.L's II. Always winding wool round first needle in E position. Push 6 (7) sts. at opposite end to carriage to E position on next 8 rows. Push all needles at opposite end to carriage to C position on next 2 rows. Knit straight until 70 (78) rows have been worked.

**Leg Shaping**

000. Cast off 5 sts at beg. of next 14 (16) rows. 25 sts. remain. Knit 2 rows. Cast on 2 sts. at beg. of next 8 rows. 9 (8) sts. at beg. of next 6 (8) rows. 95 (105) sts. 000. Knit straight until 60 (68) rows have been worked.

**Ribbers**

Transfer alt. sts. to ribber for 1 x 1 rib. 000. T2/2. Knit 6 rows. Make holes as before. Knit 6 rows. Cast off.

**Single Machines**

000. T3. Knit 24 rows. Cast off.

**To Make Up**

Pin out and press with a hot iron over a damp cloth. Sew side seams. Using contrast colour and crochet hook, work 1 row of double crochet and 1 row of shell pattern round leg opening. Thread shirring elastic round leg if required.

**Single Machine**

Turn hem at waist to wrong side and catch down.

**All Machines**

Thread elastic through waist. Press seams.

# skirt and shortie jumper

**Materials**

**Jumper:** 7 (7, 8, 8, 9) ozs. Patons Purple Heather 4-ply wool in contrast colour A, 2 ozs. in main colour B, a pair of No. 11 knitting needles, crochet hook.

**Mini-length skirt:** 4 (4, 5, 5, 6) ozs. Patons Purple Heather 4-ply wool in main colour B, 3 (3, 3, 4, 4) ozs. in contrast colour A, 3/4 inch wide elastic to fit waist. Allow extra 2 ozs. of each colour for knee-length skirt.

**Measurements**

**Jumper:** To fit bust sizes 34 (36, 38, 40, 42) ins.

Finished measurements: 34 (36, 38, 40, 42) ins.

Length to shoulder: 17 (17 1/4, 17 1/2, 17 3/4, 18) ins.

Sleeve seam 6 ins.

**Skirt:** To fit hip sizes 36 (38, 40, 42, 44) ins.

Finished measurements: 37 (39, 41, 43, 45) ins.

Length 16 ins.

**Tension**

**Jumper:** 14 sts. and 19 rows to 2 ins. after pressing.

**Skirt:** 15 1/2 sts. and 26 rows to 2 ins. after pressing.

**Abbreviations**

Sts., stitches; k., knit; inc., increase; dec., decrease; rep., repeat; foll., following; alt., alternate; beg., beginning; rem., remaining; T., tension; 000, set row counter to 000.

**JUMPER - BACK**

**Ribbers:** Using A cast on 120 (126, 134, 140, 148) sts. as 2 x 2 rib. T4/4. K. 36 rows. Transfer ribber sts. to main bed.

**Hand knitters:** Using No. 11 needles cast on 120 (126, 134, 140, 148) sts. Work in k. 2, p. 2, rib for 4 ins. Transfer sts. to machine.\*

**All machines:** 000. T7. K58 rows.

**Shape armholes**

000. Cast off 4 (4, 5, 5, 6) sts. at beg. of next 2 rows. Dec. 1 st. at each end of next 5 rows, then every alt. row until 94 (100, 106, 112, 118) sts. remain. K. straight until 66 (68, 72, 74, 76) rows have been worked.

**Shape Shoulder**

Cast off 10 sts. at beg. of next 4 rows and 6 (8, 10, 12, 14) sts. on next 2 rows. Cast off remaining 42 (44, 46, 48, 50) sts.

**FRONT**

Knit as Back to \*.

**All machines:** 000. T7. K. 2 (4, 2, 4, 6) rows.

**Divide for front**

Push 60 (63, 67, 70, 74) needles at left to E position HCL's III. Knit the right side first. K. 17 (17, 18, 18, 18) rows. Counting from centre, transfer 3rd st. on to 4th needle \* K. 17 (17, 18, 18, 18) rows. Make a hole as before \*. Rep. from \* to \* 3 times more at the same time K. until 58 rows have been worked.

**Shape armhole**

000. Cast off 4 (4, 5, 5, 6) sts. at beg. of next row. K. 1 row. Dec. 1 st. at armhole edge on next 5 rows then every alt. row until 47 (50, 53, 56, 59) sts. remain. K. straight until 41 (43, 47, 49, 51) rows have been worked.

**Shape neck**

Cast off 10 (11, 12, 13, 14) sts. at beg. of next row. K. 1 row. Dec. 1 st. at neck edge on next 4 rows then every alt. row until 26 (28, 30, 32, 34) sts. remain. K. straight until 66 (68, 72, 74, 76) rows have been worked.

**Shape shoulder**

Cast off 10 sts. at beg. of next and alt. row. K. 1 row. Cast off remaining 6 (8, 10, 12, 14) sts. Rejoin wool at side edge. HCL's I. Knit to match right side reversing all shapings.

**SLEEVES**

**Ribbers:** Using colour B cast on 84 (88, 92, 96, 100) sts. as 2x2 rib. T4/4. K. 8 rows. Change to A. K. 18 rows. Transfer ribber sts. to main bed.

**Hand knitters:** Using No. 11 needles cast on as Ribbers. Work in k. 2, p. 2, rib for 1 inch. Change to A and rib for 2 ins. Transfer sts. to machine.

**All machines:** 000. T7. K. 28 rows.

**Shape top**

Cast off 4 (4, 5, 5, 6) sts. at beg. of next 2 rows. Dec. 1 st. at each end of next 5 rows, then every alt. row 4 times. K. 3 rows. Dec. 1 st. at each end of next and every foll. 4th row 4 times in all, then every alt. row 3 (4, 5, 6, 7) times. K. 1 row. Cast off 4 sts. at beg. of next 6 rows. Cast off rem. 20 (22, 22, 24, 24) sts.

**Neckband**

With wrong side facing pick up and place on machine 40 (42, 44, 46, 48) sts. up front neck, 42 (44, 46, 48, 50) sts. from back neck and 40 (42, 44, 46, 48) sts. down front neck. 122 (128, 134, 140, 146) sts. T7. Using colour B, knit 1 row.

**Ribbers:** Transfer alt. sts. to ribber for 1 x 1 rib. \* T4/4. K. 4 rows. Make a hole over 3rd needle from each end. K. 10 rows. Make holes as before. K. 4 rows. Cast off in rib.

**Hand knitters:** With right side facing, No. 11 needles and using colour B, pick up sts. round neck as Ribbers, working in k. 1, p. 1, rib, knit as Ribbers from \*.

**To Make Up**

Pin out and press with a hot iron over a damp cloth. Join side, shoulder and sleeve seams. Turn neckband to wrong side and slip st. in place. Work 1 row of double crochet round front opening. Neaten buttonholes. Make a long twisted cord and thread through holes. Tie a knot at each end or sew on pom-poms. Press seams.

**SKIRT**

**Knee-length - Back and Front alike.**

With colour A cast on 168 (176, 184, 192, 200) sts. by hand. T4. K. 10 rows. Knit 1 loose row for hemline. T4. K. 9 rows. 000. T5. Foll. chart knit 16 rows. \* Dec. 1 st. at each end of next and every foll. 16th row until 144 (152, 160, 168, 176) sts. remain. \* K. straight until 216 rows have been worked. This will give a finished length to hips of 17 ins. (adjust). Mark ends with contrast wool.

**\*\* Shape to waist**

\*\* 000. Dec. 1 st. at each end of next and every foll. 6th row until 114 (122, 130, 138,







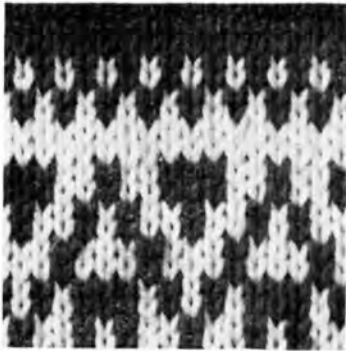

**SLEEVES**

**Ribbers:** Using C. cast on 45 (49, 53, 57) sts. as 1 x 1 rib. T6/6. Knit 14 rows. Transfer sts. to main bed for stocking-stitch.

**Single machines:** Using C., cast on 23 (25, 27, 29) sts. on alt. needles. T8. Knit 27 rows. Make a hem and knit the row. 45 (49, 53, 57) sts.

**All machines:** 000. Knit 2 rows. Following chart as before, *at the same time*, knit 6 rows. Inc. 1 st. at each end of next and every foll. 8th row (remember to knit in M. only and T9 after 30 rows of Fair Isle) until there are 69 (75, 81, 87) sts. Knit straight until 104 (112, 120, 128) rows have been worked. (This will give a finished sleeve seam of 14 (15, 16, 17) ins. Adjust length here if required.

**Shape Raglan Top**

000. Cast off 4 (4, 5, 5) sts. at beg. of next 2 rows. Knit 2 rows. Dec. 1 st. (see notes) at each end of next and every foll. 4th row 4 (3, 4, 3) times in all, then every foll. alt. row until 7 (7, 9, 9) sts. remain. Knit 1 row. Slip sts. on to a knitting needle.

**Neckband**

With wrong side facing and beg. at right side, place on machine 29 (31, 33, 35) sts. from back neck, 7 (7, 9, 9) sts. from 1 sleeve, pick up 18 (18, 19, 19) sts. down Front Neck, 11 (13, 13, 15) sts. from centre front, 18 (18, 19, 19) sts. up front neck and 7 (7, 9, 9) sts. from 2nd sleeve, 90 (94, 102, 106) sts. T10. Using M., knit 1 row. Follow rows 1 to 4 of chart. Continue in M. only. Knit 1 row.

**Ribbers:** Transfer alt. sts. to ribber. T6/6. Knit 16 rows. Cast off loosely in rib.

**Single machines:** Transfer alt. sts. on to adjacent needles and push empty needles to A position. T6. Knit 16 rows. Cast off loosely, making a chain over empty needles.

**To Make Up**

Pin out and press with a hot iron over a damp cloth. Join side, sleeve and raglan seams. Turn neckband to wrong side and slip-stitch in place. Press seams. Sew in zip on left back raglan seam if desired.

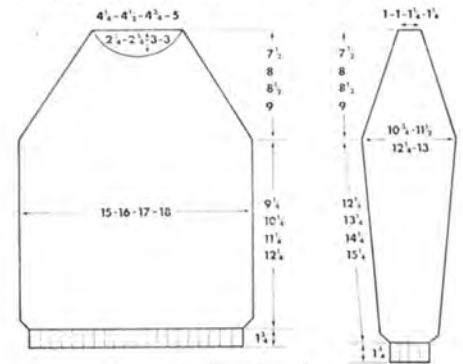

continue in red only

	X	X	X	X					30
	X	X	X	X					29
X	X	X	X	X					28
X	X	X	X	X					27
									26
									25
X	X		X		X				24
X	X		X		X				23
X		X	X						22
X		X	X						21
		X			X				20
		X			X				19
	X	X	X	X	X				18
	X	X	X	X	X				17
X		X	X						16
X		X	X						15
	X	X	X	X	X				14
	X	X	X	X	X				13
		X			X				12
		X			X				11
X		X	X						10
X		X	X						9
X	X		X		X				8
X	X		X		X				7
									6
									5
X	X	X	X	X	X				4
X	X	X	X	X	X				3
	X	X	X	X	X				2
	X	X	X	X	X				1

1 2 3 4 5 6 7 8

X = red





From: **Mrs. Tozer, Bristol.**

In volume 3, number 2 of *Stitchin'time*, you ask for suggestions regarding the Sew Easy course. I wonder whether it would be possible to include an item on combining patterns. I do not imagine that I am alone in sometimes wishing that I could make up a garment combining the bodice of pattern 'A' with the collar of pattern 'B' and possibly the sleeves of pattern 'C'! Flimsy paper patterns do not always take kindly to a lot of pinning and fitting, and one hesitates to cut out a 'combined' pattern unless one is pretty sure that it will all fit together. Some hints on how this sort of thing can be achieved and sizes checked one against another would be most appreciated.

Are readers going to know the results of the sewing survey you carried out some months ago? And what of the suggestion that you might run a Fabric Club?

*We have passed on these comments to Pat Prestidge, our sewing adviser, and she will try and incorporate them in a future issue. The results of our sewing survey are not yet available, however, we will try and hurry them along.*

From: **Mrs. Kurck 18 Boort Street, Dallas V., Australia, 3047.**

I am a member of the Jones Club and I have never heard about any club in Australia yet. I like very much this idea of 'Stitchin'link'. I would be very happy to make friends with other *Stitchin'time* members, by post and I hope it will be possible for me to get in touch with willing readers as I live so far away. I have, myself, experience in sewing and knitting and so many ideas. I will be glad to be of use. For information to other readers from another country, I have knowledge of Polish, German and French and feel this may be helpful. Hoping to get a favourable answer.

From: **Mrs. L. Eacott, Havant, Hants.**

After having some wool left over from my first garment knitted on my knitter model KH588 I discovered that by tying a different coloured wool to the inside

thread of the left-over wool it was much easier to find when I wanted to use the wool up at a later date. I thought this might be a tip for readers of *Stitchin'time*.

From: **Mrs. Bates.**

I give high praise to this latest issue of *Stitchin'time*. There appears to be something for everyone. I think the small insets of the patterns is a great idea as it gives a truer picture of the pattern. Also I like the many sizes given for each pattern, which is very useful.

I am looking forward to the start of the monthly club nights which I hope will commence again in Sheffield in September as I have missed not being able to go to the centre which was always there, and has now closed. The instructors were very helpful whenever I called.

From: **Mrs. Crawford, Stroud, Gloucester.**

I would like to take this opportunity to say how much the patterns in your magazine have improved during the past year. When I joined last year, I doubted whether I would find much use for your designs, as they seemed only suitable for the young and 'trendy'.

However, you have obviously noted the suggestions of readers, and now the patterns are much more suitable for the normal family. If I may make a suggestion, could we have more weaving patterns. I have done two from your magazine and also have tried to adapt ordinary knitting patterns for weaving, but, the tension is so very different, this has caused problems.

I also think that girls' knitted dress patterns would be very useful.

From: **Mrs. Spickett (M), Folkestone, Kent.**

Many thanks for *Stitchin'time* just received. I hope you will find the enclosed sample some use. I have used it on jumpers etc., and it makes an attractive change from the ordinary rib or hem.

Tension 5.  
Pattern:

Pull out to B position 11 needles, 3 on right hand side of needle bed, 8 on left hand side.

Push 4th and 8th needle back to 'A' position.

Depress buttons 2 and 6.

Cam levers set at 3 - knit 6 rows.

With left hand cam lever at 1 knit 2 rows. (Buttons 2 and 6 brought out by using set lever.)

From: **Mrs. Kitchen, Healing, Nr. Grimsby.**

I feel I must write to you on my Jones Simplicity's birthday. I bought it two years ago this week, it was the best thing I ever did, I just cannot imagine life without it, I have knitted 640 garments at least and I think that's pretty good going. I am not claiming any records. I just feel extremely pleased with myself and wanted to tell you what pleasure your machine has brought to me. I never use any pattern, and have made loads of Fair Isle patterns up for kiddies jumpers, it is amazing just what one can do with it. Next, a Ribbing Attachment, as I knit (the button bands) by hand for cardigans and this is such tedious work when the whole body of the cardigan takes only an hour.

*Editor's Comment.*

We are very pleased that Mrs. Kitchen has put her machine to such great use but are sorry to disappoint her in that we have no ribbing attachment for the Simplicity model. If any customer with the Simplicity would like to arrange a part exchange for a model with a ribber they should contact the Editor.

From: **Mrs. Hilda Bailey, Hednesford, Staffs.**

Dear Sirs,

A tip for what it is worth for your sewing readers. I have done quite a lot of dressmaking and made my own and my families' coats. I never had a sleeve board so to press the sleeve top and shoulder seam I made a pad with a towel, pushed this under the seam as a pad, then put my damp cloth over the right side of the garment to press lightly and have always finished with a neat sleeve seam.



## HANDBAG

### Materials.

4 ozs. Twilleys Crysett. No. 3 Cotton. Red.  
 $\frac{1}{2}$  oz. Twilleys Crysette. No. 3. Cotton.  
 White.

$\frac{1}{2}$  yd. Lining.

Handle.

Cast on 88 sts. anticlockwise, Tension 7  
 in main colour. Knit 16 rows st.st.

Knit 16 rows Fair Isle in Chequer Board  
 Pattern in Instruction Manual, page 29.  
 Break off White Wool.

Release all Buttons and set machine for  
 st.st. knit 1 row. Tension 6. Follow Lace  
 pattern chart 618 on page 144 in KH585.  
 2gn. book, knit 162 rows lace. Knit one  
 row st.st. Set Machine for Fair Isle.

Tension 7. Knit one row st.st. Knit 16  
 rows Chequer Board. Knit 16 rows st.st.  
 Cast off loosely.

### To Make-up

Cut lining to size, place pocket centre  
 middle 4" from top, and stitch on, fold  
 lining in half and stitch sides together.  
 Fold bag in half, and stitch sides together,  
 turn lining inside out and tack to bag,  
 turn top hems of bag over lining, stitch in  
 place. Fit handle.

From: Mrs. Leonie Brown, Leeds.



## LAMP SHADE

### Materials.

1 oz. 4-ply Wool.

$\frac{3}{4}$  yd. Fringe.

Tension 6.

Cast on 80 sts. knit 11 rows st.st.

Using Lace Pattern No. 607 on page 141  
 of the 585 Knitting book.

R.C.000 work 16 rows. Increase. 1st at  
 each end of every 3rd row. R.C.90.

R.C.000 work 40 rows increasing 1st. at  
 each end of next and every following 4th  
 row. 112 sts. then every 5th row 124 sts.  
 Knit 12 rows.

### To Make-up

Stitch sides together, stitch on to frame at  
 top and bottom and add fringe.

From: Mrs. Pauline Lock, Leeds.



## WOVEN PLACE MATS

### Materials

2 Balls of Twilleys Lyscordet No. 5. White.

4 ozs. D.K. Baby Quicker Knit. Pink.

Cast on 100 sts. Tension 6.

Knit 2 rows.

Working pattern 234 in 2gn book for 585  
 machine.

338 in 2gn. book for 588  
 machine.

Knit 96 rows.

Knit 2 rows st.st. Cast off.

Make Tassels or crotchet round edge.

### Matching Small Mat

Cast on 50 sts. Knit two rows.

Work 60 rows in lace and weaving pattern.

Knit 2 rows st. st.

Cast off.

Add fringe or crotchet round edge.

From: Mrs. Pearl Johnson - Leeds Knitting  
 Centre.









# knitted doll

Designed by Mrs. Joyce Guy of Aldridge, Staffs.

## Materials required

4 oz. Robin Tricel 4-ply Snowfrost (white). 2 oz. Robin Banana Whip (yellow). 5 oz. Pearl Pink. 10 oz. Royal Sapphire. 1 oz. 3-ply White. Oddments: Red, Brown, Blue to embroider face features. Kapok for filling. One buckle. One cardboard tube. Small amount of elastic for pants.

## Tension

9½ sts. and 12 rows to the inch.

## Body

Knit two pieces using Royal Sapphire. Sealed edge method. Cast on 74 sts. T5. Knit 140 rows plain.

## Shape Shoulders

Cast off 8 sts. at beginning of next 6 rows. Cast off remaining 26 sts. Sew the two pieces together leaving centre 26 sts. (cast off st.) and then open. Stuff the body. Fill empty cardboard tube (toilet roll holder) with kapok to help hold shape. Put into body leaving half of tube sticking out of body.

## Head

T5. Two pieces alike. One in Pearl Pink. One in Banana Whip. Cast on 30 sts. using sealed edge method. Knit two rows. \* Increase one stitch each end. Knit one row \*. Repeat from \* to \* 15 times altogether. (60 sts., row counter 17). Knit 64 rows plain (row counter 81). \*\* Decrease one stitch each end. Knit one row \*\*. Repeat from \*\* to \*\* 15 times altogether. Knit two rows. Cast off.

Sew two pieces together leaving cast off edges open. Stuff with kapok. Sew to body pushing the half of the cardboard tube which is sticking out of the body, into the head. This gives support to the head.

## Arms

In Pink Pearl. Knit two pieces. T5., using sealed edge method. Cast on 38 sts. \* Knit 19 rows. Increase one stitch each end. \* Repeat from \* to \* 7 times. (52 sts.). Knit 20 rows, row counter 153. Cast off. Fold in half lengthways. Sew up leaving cast off edge open. Stuff and sew to body with seam under arm.

## Legs

Knit two pieces in Pink Pearl using sealed edge method. Cast on 40 sts. T5. \* Knit 27 rows. Increase 1 st. each end \*. Repeat from \* to \* 8 times altogether. 56 sts., row counter 216. Knit 27 rows. Cast off. Fold in half lengthways. Sew together leaving cast off edge open. Stuff. Sew to body with seam at back of body.

## Boots

Snowflake (white). Using sealed edge method. T5. Cast on 66 sts. Knit 2 rows. \* Increase one st. each end. Knit 4 rows \*. Repeat from \* to \* 3 times altogether. \*\* Decrease one stitch each end. Knit 2 rows \*\*. Repeat \*\* to \*\* 4 times altogether. Cast off 11 sts. beginning next 2 rows. Knit 54 rows and cast off. Fold in half leaving cast off edge open. Sew together. Stuff.

Stuff foot section. Place over end of leg. Sew cast off edge to leg. With Royal Sapphire wool sew cross stitches for laces.

## Hands

Piece A: Using Pink Pearl, sealed edge method, cast on 17 sts. T5. \* Knit 4 rows. Increase one stitch each end \*. Repeat from \* to \* 4 times altogether. Knit 6 rows (25 sts.). Knit carriage at right side of bed, bring 20 sts. at left of bed forward to E position H.C.L. II.

## Thumb

Knit on 5 sts. at D position as follows: Increase one st. at right of bed. Knit 8 rows. Decrease one stitch either side of working stitches. Knit 2 rows. Cast off.

H.C.L. back to position I, knit 10 rows at 20 sts. H.C.L. back to II, bring 15 sts. forward to E position.

## First Finger

Knit on 5 sts. at D position, increase one stitch at right of bed. Knit 10 rows. Decrease one stitch each side. Knit two rows. Twice. Cast off remaining 2 sts.

## Second Finger

Bring 5 sts. back until stitch loops just touch latches. Increase one stitch at right of bed. (H.C.L.'s II) knit 14 rows. Decrease 1 st. each side. Knit 2 rows twice. Cast off last 2 sts.

## Third Finger

Bring 5 sts. back until stitch loops just touch latches (H.C.L.'s II) Increase 1 st. at right. Knit 10 rows. Decrease 1 st. each side. Knit 2 rows. Twice. Cast off remaining 2 sts.

## Little Finger

H.C.L.'s back to position I, increase 1 st. at right of bed. Knit 6 rows. Decrease 1 st. each side. Knit 2 rows twice. Cast off remaining 2 sts.

To knit Piece B: Knit as above, reversing all shapes. Sew one A piece and one B piece together and stuff. Sew to arm.

## Hat

Snowflake (white). If Ribber attachment: cast on 160 sts. as for 1 x 1 rib. T3/2. Knit 10 rows. Using transfer tool, transfer stitches to knitting bed. T5. Knit 4 rows.

Without Ribber - work as follows: Continental Rib. Bring 160 sts. forward to B position. Press needle selector buttons 1, 3, 5 and 7. Reverse lever A or (plus for 588). Set lever.

Take rear sts. back to A position. T10. Knit one row. Drop comb. T3. Knit 9 rows. T6. Knit 1 row. T3. Knit 10 rows.

Bring sts. returned to A position at start of knitting, back to B position. Reverse lever to B or (Minus). Set lever. Bring these empty needles forward to E position. Transfer stitches up from comb. T5. Knit 4 rows.

H.C.L.'s to II, bring 120 sts. counting from left of bed (carriage at right) forward to E position. Knit on 40 sts. at D position. Work as follows: \* Decrease 1 st. each side of 40 sts. Knit 5 rows \*. Work from \* to \* until you have 28 sts. Decrease 1 st. each side. Knit 4 rows until you have 6 sts. Cast these off. Bring 40 sts. at left of bed back until stitch loops just touch latches. Knit as on first 40 sts. Repeat on next block of 40 sts. Do this until all sts. have been knitted.

## Peak of Hat

Knit one piece. Cast on 44 sts. using sealed edge method. T5. Knit 2 rows. \* Decrease 1 st. each end. Knit 4 rows \*. Repeat from \* to \* until 28 sts. Knit 1 row. Tension 8 for crease row. T5. \* Increase 1 st. Knit 4 rows \*. Repeat from \* to \* until you have 44 sts. Cast off.

Fold in half. Cast on edge to cast off edge together. Right sides together. Sew, leaving cast on and cast off edge open. Turn through. Stitch to inside of ribbing on hat. Stitch hat on to head.

## Pants

Knitting carriage at right of bed, bring 78 sts. to D position. Press needle selector buttons 1, 3, 5 and 7. Set lever. Both Part Buttons in. T8. Knit 1 row.

Press Plain Button. T5. Knit 9 rows. T8. Knit 1 row for crease row. T5. Knit 10 rows.

Set lever. Bring sts. brought forward when set to E position. Transfer sts. up from comb. Knit 30 rows. T5.

Cast off 20 sts. beginning next 2 rows. Knit 4 rows on these 16 sts. Cast on 20 sts. at beginning of next two rows using sealed edge method. Knit 40 rows. Tension 5. Knit 1 row. T8. Fold line. Knit 10 rows. T5. Cast off. Fold cast off edge over at crease line. Sew hem. Fold in half lengthways. Sew side seams. Put in elastic. Put on doll.

## Skirt

In Royal Sapphire: Arrange needles as follows: 60 needles position B. One needle position A. 5 Needles position B. Cast on by hand using sealed edge method. T5. Knit 10 rows. \* Knit 4 rows. T5 in white 3-ply. Knit 10 rows T5 in Royal Sapphire 4-ply. Knit 1 row T5 in Royal. Knit 20 rows, T5 in Royal \*. Work from \* to \* is one pleat. Work 17 pleats altogether. Knit 4 rows T5 in white 3-ply wool. Knit 10 rows. T5 in Royal 4-ply. Cast off.

Join side seam, which is the cast on and cast off edge. Fold 5 sts. up to form hem of skirt. Fold and sew pleats into place, the 4 rows of white forming edge of pleat. Sew skirt three-quarters of the way down body of doll.

## Belt

Cast on by hand using sealed edge method. Cast on as follows: 5 sts. position B. 1 St. position A. 10 sts. position B. 1 st. position A. 5 sts. position B. Knit 250 rows. T5. Cast off. Fold lengthways with 1 st. missing to form edge of belt on both sides. Sew on to body, covering the top of skirt, with buckle threaded into position.

## Braid

For cuff bracelets and neckband. Worked as follows: Arrange stitches as follows: Bring forward to position B 3 needles. The centre stitch being the stitch with the bow symbol, on the needle bed. Leave next 2 sts. at position A. 1 st. forward to position B, having the diamond symbol on the bed. 2 needles at A and 3 needles forward to B position. The centre stitch of the 3 should also have the bow symbol on the bed. Cast on 7 working sts. in position B by hand, using the sealed edge method. The 2 weaving buttons on carriage to T, knit 2 rows. Slide dial 1, reverse buttons to A or Plus. Press needle selector buttons 1 and 5, both H.C.L.'s to III. Set lever and knit 4 rows. Left H.C.L. to I and knit 2 rows. Repeat last 6 rows to required length. Cast off.





## CIRCULAR MAT

From: Mrs. C. Turner, 25 Queens Road, Christchurch, Hants.

1 ball Coats No. 5 Cotton.  
(makes two mats).

Tension 3, H.C.L.s 11.

Bring 16 needles into working position, with waste wool knit 7 rows. Join in Cotton, knit 1 row. \*\*Always taking cotton round first needle in H.P. push 4 needles opposite carriage into E. position on the next and following alternate rows. 3 times. Knit 1 row. Push 4 needles opposite carriage to C. position on next and following alternate rows. Knit 1 row. Counting from the right, transfer the 3rd and following alternate stitches to the left, making sure that all empty needles are in working position knit 2 rows.\*\*

These 14 rows are repeated 13 times. When completed graft the two edges, to complete circle. Fill centre with Double Crochet, and Shell Crochet round edge. 2 Shells to each section.

These mats can be knitted on all models.



## Stichin' Link

A reminder to our readers regarding the Stichin' Link scheme, which has been in operation since May of this year.

If you would like to exchange ideas and experience with another machine owner by post, please write initially to Finchley and we will link you with another Member in a different part of the country.

We think this scheme will prove of particular interest during the Autumn and Winter months, and hope that many of our readers will wish to participate.





# attachments

All attachments are very simple to fit. First raise the needle by loosening the thumb screw and turning the balance wheel towards you. Remove ordinary sewing foot and fix any of the following attachments in its place.

## Darning & Embroidery

Turn Drop Feed Knob to Darn position (see instruction book under heading "For Darning and Embroidery").

Place material in embroidery hoop (when available), otherwise hold material with both hands tightly so that you can move material smoothly in any direction you desire.

Place material under Darning foot, lower presser bar lever and proceed, starting slowly stitching from top to bottom until you have covered the hole, and then from side to side likewise (see insert in picture).

Proceed to fill in darn with similar rows of stitching, as close and as neat as possible.

When embroidering, move the material in any direction filling in small stitches, to the pattern you desire.

Leaf and flower patterns, writing or objects should be drawn or transferred on to the material to make embroidery easier.

When you have completed your darning, make certain that you return Drop Feed Knob to normal sewing position.

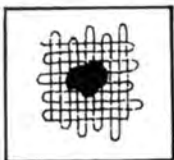
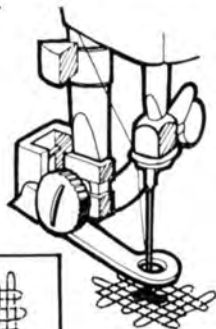

## Cloth Guide

Attach to the inside of the machine base, using the machine provided. Adjust the cloth guide sideways measuring from the needle. Feed the material in the usual way with the edge against the cloth guide.

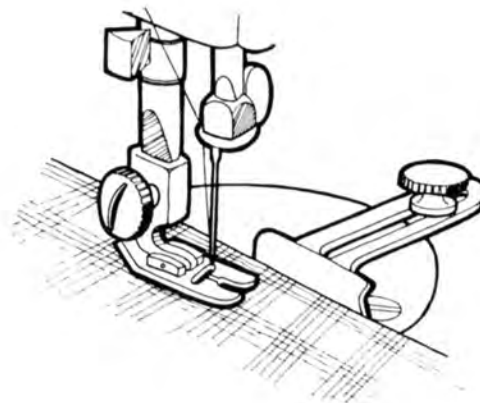

## Buttonhole Foot

Remove presser foot and place on button hole foot. Set machine to satin stitch. Set the position of the lever at left, stitch down left side of buttonhole. Leaving the needle in the right hand throw, and using as a pivot, turn the work away from you, remove the needle from the work, set Zig-Zag lever to 5 and bartack. Remove the needle and set in 2 position and stitch second side of buttonhole. Remove the needle, set Zig-Zag lever to 5, bartack. With Zig-Zag lever at Zero lock with two stitches.

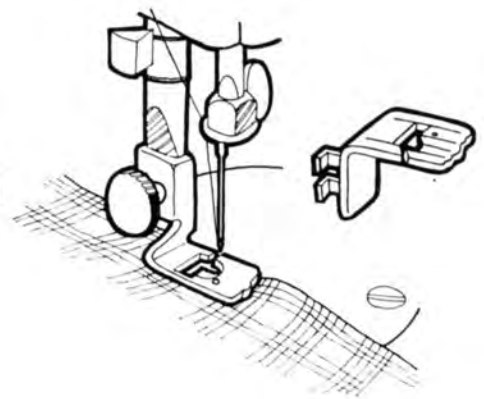



## Hemming 1

Some material will feed into the cone of the hemmer very easily, but it is sometimes better to cut off the corner of the material (as shown in diagram) to make an easier start.

Always trim the whole side of the material evenly. This will help in guiding the material and producing a better hem.

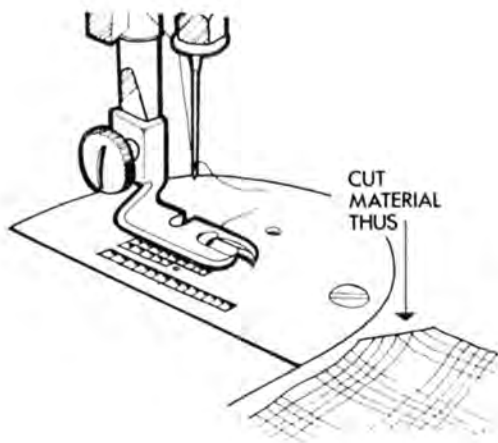

## Hemming 2

Insert material into the cone until it reaches the needle hole.

Lower presser bar lever and make first stitches slowly, increasing speed gradually.

Guide material with thumb and forefinger of the right hand so that material curls into cone of hemmer.

Allow material to feed evenly into hemming foot, do not pull.

Considerable practice is required to obtain an even hem.

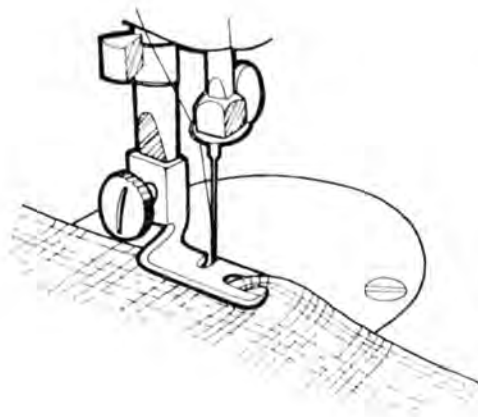

## Ruffling or Gathering

Place stitch lever to the position indicating longest stitch (see instruction book under heading "To regulate length of stitch").

Place material under foot, lower presser bar lever and proceed to sew, allowing it to gather as required.

On certain materials it is sometimes better to place the finger behind the foot (see picture on the left) to increase the amount of gathering.

When you have finished gathering, move stitch lever back to stitch required for normal sewing.

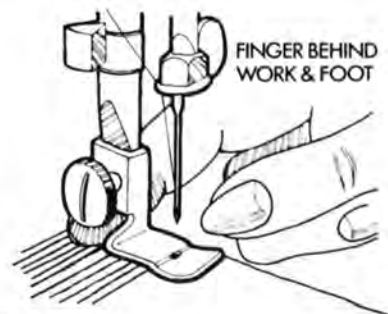

## Button Sewing Foot

This is used for sewing on buttons. Remove the ordinary foot and attach the button foot. Set drop feed to darn. Make sure the needle is in the full left position, and insert needle into the first hole of the button. Make one stitch, then move Zig-Zag lever to width between holes on button, insert needle in the right hand position, then sew three Zig-Zag stitches. Move Zig-Zag lever back to left and lockstitch.

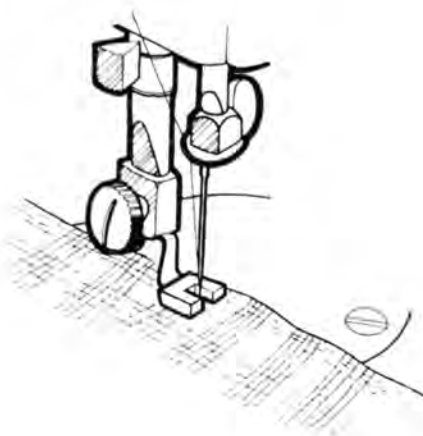

## Hinged Pressure Foot

For use with Zig-Zag machines for working with fine materials. Remove ordinary Zig-Zag foot and fit straight stitch foot making sure that the Zig-Zag needle position is at zero. Feed material in the ordinary way.

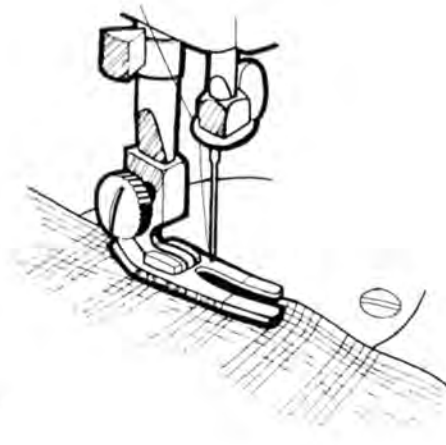

## How to use the adjustable Zipper Foot

1. The diagram shows the Zipper Foot set to sew on the right of the needle, close to the edge of the material which is turned to form a placket or opening, to avoid striking the Zipper links.
2. To sew on the opposite side of the zipper, loosen screw and slide the zipper foot over to the left of the needle, so as to sew close to the edge without striking the zipper links.

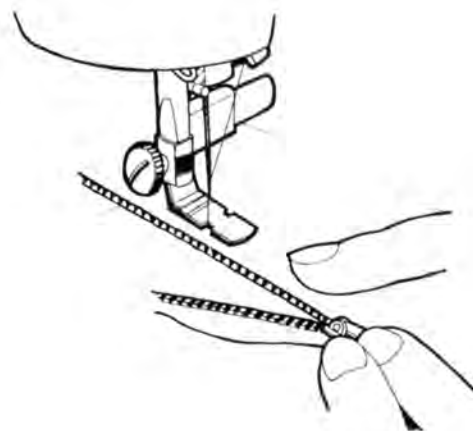



# mans lumber jacket

## Materials

16 (17, 18, 20, 21) ozs. Sirdar Talisman 4-ply wool, open ended zip to fit front of jacket, crochet hook.

## Measurements

To fit chest sizes 34 (36, 38, 40, 42) ins.  
Finished measurements: 37 (39, 41, 43, 45) ins.  
Length to shoulder 24 (24½, 26, 26½, 28) ins.

Sleeve seam 18 ins.

## Tension

14 sts. and 20 rows to 2 ins. over st. st.

## Abbreviations

Sts., stitches; inc., increase; dec., decrease; alt., alternate; k., knit; N., needles; rem., remaining; foll., following; beg., beginning; rep., repeat; T., tension; M.B., main bed; 000, set row counter at 000.

## Notes

Figures in brackets refer to the larger sizes respectively.

## Cable Pattern

Knit 8 rows.

**1st panel:** Cross sts. 1, 2 and 3 over 4, 5 and 6.

**2nd panel:** Cross sts. 4, 5 and 6 over 1, 2 and 3. Knit 8 rows.

**1st panel:** Cross sts. 4, 5 and 6 over 1, 2 and 3.

**2nd panel:** Cross sts. 1, 2 and 3 over 4, 5 and 6. These 16 rows complete 1 pattern.

## BACK

**Ribbers:** Cast on 132 (138, 146, 152, 160) sts. as 1x1 rib. T3/3. K. 20 rows. Transfer ribber sts. to M.B.

**Stocking stitch hem.** Cast on 132 (138, 146, 152, 160) sts. T6. K. 39 rows. Make a hem and k. the row.

**All machines:** 000. T7. K. straight for 140 (140, 150, 150, 160) rows. This will give a length of 16 (16, 17, 17, 18) ins. to armhole. If adjustment is required it can only be made in groups of 2 ins. as zips are made in variations of 2 ins. in length.

## Shape armholes

000. Cast off 5 (5, 6, 6, 7) sts. at beg. of next 2 rows. Dec. 1 st. at each end of next 7 rows then every foll. alt. rows until 94 (100, 106, 112, 118) sts. remain. K. straight until 80 (86, 90, 96, 100) rows have been worked.

## Shape shoulders

Cast off 6 (6, 7, 7, 7) sts. at beg. of next 6 rows and 4 (4, 6, 6, 8) sts. at beg. of next 2 rows. Cast off rem. 38 (40, 42, 44, 46) sts.

## RIGHT FRONT

**Ribbers:** Cast on 66 (69, 73, 76, 80) sts. as 1x1 rib. T3/3. K. 20 rows. Transfer ribber sts. to M.B.

**Stocking stitch hem:** Cast on 66 (69, 73, 76, 80) sts. T6. K. 39 rows. Make a hem and k. the row.



**All machines:** 000. T7. Counting from the left transfer 14th (16th, 17th, 19th, 20th) st. and foll. 7th, 12th and 19th st. on to adjacent needle. Push empty needles to A position. Foll. cable pattern, k. straight until 140 (140, 150, 150, 160) rows have been worked. (K. 1 row extra for Left Front.)

## Shape armhole

000. Cast off 5 (5, 6, 6, 7) sts. at beg. of next row. K. 1 row. Dec. 1 st. at armhole edge on next 7 rows then every foll. alt. row until 47 (50, 53, 56, 59) sts. remain. K. straight until 59 (59, 69, 69, 79) rows have been worked.

## Shape neck

Cast off 9 (9, 11, 11, 13) sts. at beg. of next row. K. 1 row. Dec. 1 st. at neck edge on next 4 rows then every foll. alt. row until 28 (30, 32, 34, 36) sts. remain. K. straight until 80 (86, 90, 96, 100) rows have been worked.

## Shape shoulder

Cast off 6 (6, 7, 7, 7) sts. at beg. of next and alt. rows until 4 (6, 4, 6, 8) sts. remain. K. 1 row. Cast off.

## LEFT FRONT

Knit as Right Front reversing all shaping and arranging cable panels to match Right Front.

## SLEEVES

**Ribbers:** Cast on 58 (62, 66, 70, 74) sts. as 1x1 rib. T3/3. K. 20 rows. Transfer ribber sts. to M.B.

**Stocking stitch hem:** Cast on 58 (62, 66, 70, 74) sts. T6. K. 39 rows. Make a hem and knit the row.

**All machines:** 000. T7. Arrange 20 centre sts. for cable pattern as Right Front. Foll. cable pattern. K. 16 rows. Inc. 1 st. at each side of next and every foll. 6th row until there are 100 (104, 108, 112, 116) sts. K. straight until 160 rows have been worked. This will give a sleeve seam of 18 ins. Adjust length here if required.

## Shape top

Cast off 5 (5, 6, 6, 7) sts. at beg. of next 2 rows. Dec. 1 st. at each end of next 7 rows then every foll. 4th row 4 (4, 5, 5, 6) times. K. 1 row. Dec 1 st. at each end of next and every foll. alt. rows until 52 sts. remain. K. 1 row. Cast off 3 sts. at beg. of next 6 rows and 4 sts. on next 4 rows. Cast off remaining 18 sts.

## COLLAR

**Ribber:** Cast on 99 (107, 107, 115, 115) sts. as 1x1 rib. T3/3. K. straight for 36 rows. Cast off 8 sts. at beg. of next 8 rows. Cast off remaining 35 (43, 43, 51, 51) sts.

**Stocking stitch collar:** Cast on 35 (43, 43, 51, 51) sts. by hand. T5. K. 1 row. Cast on 8 sts. at beg. of next 8 rows. 99 (107, 107, 115, 115) sts. 000. T6. K. straight for 36 rows. T10. K. 1 row. T6. K. 36 rows. T5. Cast off 8 sts. at beg. of next 8 rows. Cast off remaining 35 (43, 43, 51, 51) sts.

## To Make Up

Pin out and press with a hot iron over a damp cloth. Join side, shoulder and sleeve seams. Sew in sleeves. Work 1 row of double crochet along front edges. Sew in zip. Sew shaped edge of ribbed collar in position. Sew st.st. collar in position, turn to wrong side and slip-st. in place. Press seams.







### Shape top

000. Cast off 3 sts. (see Notes) at beg. of next 2 rows. Dec. 1 st. at each end of next 3 (3, 3, 5, 5, 7, 7) rows then every alt. row 6 (6, 6, 7, 7, 6, 6) times. Knit 2 rows. Dec. 1 st. at each end of next and every foll. 3rd row 7 (7, 7, 7, 7, 8, 8) times in all. Dec. 1 st. at each end of next 6 (8, 10, 8, 10, 9, 11) rows. Cast off 4 sts. at beg of next 6 rows. Cast off remaining 18 (18, 18, 20, 20, 22, 22) sts.

### Left Front Facing

With purl side of work facing, pick up and place on M.B. 21 sts. from cast-on edge beg. at front edge. T7. 000. Knit straight for the same number of rows as knitted for Left Front to beg of armhole shaping. 000. Inc. 1 st. at side edge at beg. of next and every foll. 4th row 12 times in all then every alt. row 6 (7, 9, 10, 11, 13, 14) times. Carriage is at front edge.

### Shape Neck

Cast off 13 (14, 15, 16, 17, 18, 19) sts. at beg. of next row. Continue to inc. 1 st. at side edge as before at the same time knit 1 row. Cast off 4 sts. at beg. of next row and 2 sts. on foll. 2 alt. rows. Knit 1 row. Dec. 1 st. at neck edge on next and every foll. alt. rows 5 times in all. Keep neck edge straight but continue to inc. 1 st. at side edge until there are 22 (23, 24, 25, 25, 26, 26) sts. Knit 5 (3, 3, 1, 1, 1, 1) rows.

### Shape Shoulder

Cast off 7 (7, 8, 8, 8, 8, 6) sts. at beg. of next row and 7 (7, 8, 8, 9, 9) sts. on alt. row. Knit 1 row. Cast off remaining 8 (9, 8, 9, 8, 9, 11) sts.

### Right Front Facing

Knit to match Left Front reversing shaping and making buttonholes to match Right Front over needles 5-9 inclusive from front edge.

### Cuffs

Unravel contrast wool and with purl side of work facing pick up and place on machine 62 (66, 68, 72, 74, 78, 80) sts. dec. 10 (10, 12, 12, 14, 14, 16) sts. evenly along the row. T6. Knit 26 rows. Knit 1 loose row. Cast off using chain method.

### Collar

Cast on 32 (36, 40, 44, 48, 52, 56) sts. on M.B. by hand. T6. Knit 1 row. Cast on 7 sts. at beg. of next 10 rows. 102 (106, 110, 114, 118, 122, 126) sts. T7. Knit 4 rows. Inc. 1 st. at each end of next and every foll. 4th row 5 times in all. Knit 4 rows. Dec. 1 st. at each end of next and every foll. 4th row 5 times in all. Knit 4 rows. T6. Cast off 7 sts. at beg. of next 10 rows. Cast off remaining 32 (36, 40, 44, 48, 52, 56) sts.

### To Make Up

Pin out and press with a hot iron over a damp cloth. Join side, shoulder and sleeve seams. Sew in sleeves. With purl sides together sew front facing to front edge as far as neck shaping. Sew narrow ends of collar and turn to purl side. Tack curved edge of collar to right side of neck edge beginning and ending at same distance from front edges. Tack facings to neck shaping and collar. Sew through all thicknesses. Catch facings on to shoulder seams. Sew bias binding along back neck if required. Turn facings to wrong side. Turn bias binding over back neck seam and slip-stitch in place. Work 1 row of crochet along outer edge of facings. Turn hem at lower edge and cuffs to wrong side and



slip-stitch in place. Press seams. Press collar and rever very firmly.

### SKIRT

#### Back and Front alike

Cast on 134 (140, 148, 154, 162, 168, 176) sts. on M.B. by hand. T6. Knit 12 rows. Arrange needles for 4 x 1 rib as Back. Move Ribber to H. Pick up loops from M.B. and place on empty needles on Ribber. 000 T7. Knit 136 (136, 140, 140, 146, 146, 146) rows. This will give a finished length of 21 (21, 21½, 21½, 22, 22, 22) ins. Adjust length here if required. Mark ends with coloured wool.

#### Shape to waist

Dec. 1 st. (see Notes) at each end of next

and every foll. 6th row 5 times in all then every foll. 4th row until 102 (108, 116, 122, 130, 136, 144) sts. remain. Knit 3 rows. Move Ribber to P. Arrange needles for 1 x 1 rib. T3. Knit 10 rows. Knit 1 loose row. Transfer Ribber sts. to M.B. and cast off using chain method.

### To Make Up

Pin out and press with a hot iron over a damp cloth. Join side seams. Cut elastic to fit waist and sew narrow ends into a ring. Hold elastic inside waistband and work a herringbone stitch over elastic on to every alt. st. of ribbing. Turn hem to wrong side and slip-st. in place. Press seams.



# girls dress with pleated skirt

## Materials

11 (11, 12, 12, 13)  $\frac{3}{4}$  oz. balls Listers Bel Air 4-ply yarn in main colour A, 1 ball contrast yarn B, light-weight zip to fit back opening.

## Measurements

To fit chest sizes 22 (24, 26, 28, 30) ins.

Finished measurements 24 (26, 28, 30, 32) ins.

Length from centre back 16 $\frac{1}{2}$  (19 $\frac{1}{2}$ , 22 $\frac{1}{2}$ , 25, 27 $\frac{1}{2}$ ) ins.

Sleeve seam 10 (11 $\frac{1}{2}$ , 13, 14 $\frac{1}{2}$ , 16) ins.

## Tension

15 sts. and 21 rows to 2 ins.

## Abbreviations

K., knit; sts., stitches; inc., increase; dec., decrease; rep., repeat; foll., following; alt., alternate; beg., beginning; T., tension; 000, set row counter at 000.

## Notes

The pleated skirt is knitted sideways. To lengthen or shorten the skirt, add or subtract sts. from the cast on row. Fully fashioning at raglan edges is worked by transferring the 3rd st. on to the 4th needle and moving the 2 end sts. 1 needle in.

## FRONT

Using colour A cast on 94 (98, 106, 114, 122) sts. by hand. 000. T6. K. straight for 64 (80, 96, 106, 116) rows.

## Shape Raglan Armholes

Cast off 3 (3, 4, 4, 5) sts. at beg. of next 2 rows. K. 1 row. Dec. 1 st. (see notes) at each end of next and every foll. 3rd row 6 (4, 6, 4, 6) times in all then every alt. row until 46 (48, 52, 56, 60) sts. remain. K. 1 row. Using odd length of yarn cast off 12 (14, 14, 16, 16) sts. at centre. Push sts. at left to E position. H.C.L.'s III. K. the right side first \* Dec. 1 st. at both ends of next and every foll. alt. row until 5 (5, 5, 6, 6) sts. remain. Continue raglan shaping only until 2 sts. remain. Cast off. H.C.L.'s I. Rejoin wool at raglan edge and K. to match right side from \*.

## RIGHT BACK

Using colour A cast on 45 (49, 53, 47, 61) sts. by hand. 000. T6. K. straight for 64 (80, 96, 106, 116) rows. K. 1 row extra for Left Back.

## Shape Raglan Armholes

000. Cast off 3 (3, 4, 4, 5) sts. at beg. of next row. K. 2 rows. Dec. 1 st. (see notes) at armhole edge on next and every foll. 3rd row 6 (4, 6, 4, 6) times in all then every alt. row until 14 (15, 16, 17, 18) sts. remain. Slip-st. on to a knitting needle.



## LEFT BACK

K. as Right Back reversing all shapings.

## SLEEVES

**Ribbers:** Using colour B cast on 50 (52, 54, 56, 58) sts. T4/4. K. 1 row. Change to colour A and K. 13 rows. Transfer ribber sts. to main bed for st.-st.

**Mock rib:** Push 26 (27, 28, 29, 30) alt. needles to B position. Using waste wool cast on and K. 4 rows. Change to colour A. T5. K. 12 rows. Change to colour B and k. 4 rows. Change to colour A and k. 12 rows. Make a hem. T6. K. 2 rows, dec. 1 st. on 2nd row. 50 (52, 54, 56, 58).

**All machines:** 000. T6. K. 6 rows. Inc. 1 st. at each end of next and every foll. 8th row until there are 70 (76, 82, 88, 94) sts. K. straight until 90 (106, 122, 136, 152)

rows have been worked. Adjust length here if required.

## Shape Raglan Top

Cast off 3 (3, 4, 4, 5) sts. at beg. of next 2 rows. K. 1 row. Dec. 1 st. (see notes) at each end of next and every foll. 3rd row 6 (4, 6, 4, 6) times in all then every alt. row until 8 sts. remain. K. 1 row. Slip-sts. on to a knitting needle.

## NECKBAND

With wrong side facing and beg. at right place on machine 14 (15, 16, 17, 18) sts. from Right Back, 8 sts. from one sleeve, pick up and place on machine 31 (33, 35, 37, 39) sts. round front neck, 8 sts. from 2nd sleeve and 14 (15, 16, 17, 18) sts. from Left Back. 75 (79, 83, 87, 91) sts. T6. Using colour B K. 1 row.



# childs sweater and hat

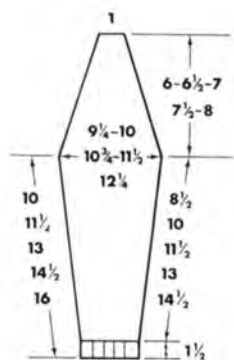
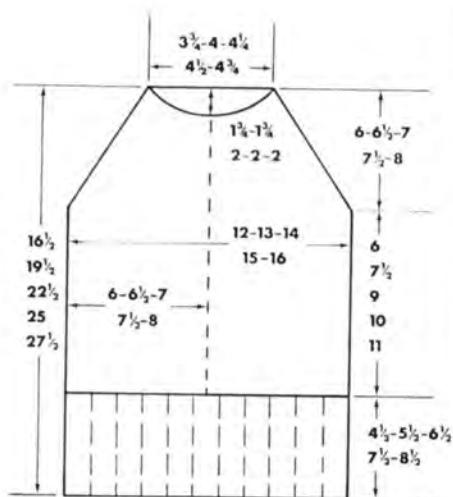

**Ribbers:** Transfer every alt. st. to ribber for 1 x 1 rib. T4/4. K. 2 rows. Change to colour A. K. 5 rows. Change to colour B. K. 4 rows. Change to colour A. K. 7 rows. K. 1 loose row. Transfer ribber sts. to main bed and cast off using chain method.

**Mock rib:** Transfer every alt. st. to adjacent needle. T5. K. 2 rows. Change to colour A. K. 6 rows. Change to colour B. K. 4 rows. Change to colour A. K. 6 rows. Cast off loosely making a chain over empty needles.

## SKIRT

Using waste wool cast on 34 (42, 49, 57, 64) sts. K. 4 rows. Change to colour A.\* T6. K. 20 rows. Change to colour B. K. 1 row. T9. K. 1 row (fold line). T.6 K. 2 rows. Change to colour A. K. 7 rows. T9. K. 1 row. (inside fold line) \* Rep. from \* to \* 23 (25, 27, 29, 31) times more. K. 8 rows at end instead of 1 loose row. Slip sts. onto a knitting needle.

## TO MAKE UP

Work 1 row of double crochet along one edge of skirt. Tack pleats in place and press with a warm iron over a damp cloth. Remove tacking thread and press again. With right sides together replace sts. from needle and loops from 1st row in main colour back on machine on top of each other and cast off as one. Pin out and press other pieces with a warm iron over a dry cloth. Join side, sleeve and raglan seams. Fold neckband to inside and slip-st. in place. Sew plain edge of pleated skirt to bodice, matching seam of skirt to opening at bodice. Sew back bodice leaving opening for zip. Work a row of double crochet round opening. Sew in zip. Press seams.

## Materials

**Sweater:** 8 (9, 10, 11) ozs. Listers Lavenda Double Knitting in main colour. 2 (2, 3, 3) ozs. in Lockinvar Double Knitting. 5-inch zip.

**Hat:** 2 (2, 3, 3) ozs. Listers Lavenda Double Knitting in main colour, 1 oz. in Lockinvar Double Knitting.

## Measurements

**Sweater:** To fit chest sizes 22 (24, 26, 28) ins.

Finished measurements 24 (26, 28, 30) ins. Length at back neck 14 (15 1/2, 17, 18 1/2) ins.

Sleeve seams 10 (11 1/2, 13, 14 1/2) ins.

**Hat:** Depth 6 3/4 (7, 7 1/4, 7 1/2) ins.

## Tension

13 1/2 sts. and 16 1/2 rows to 2 ins after pressing.

## Abbreviations

K., knit; sts., stitches; inc., increase; dec., decrease; rep., repeat; foll., following; alt., alternate; beg., beginning; rem., remaining; M.B., main bed; T., tension; 000., set row counter at 000.

## Notes

**K.H. 588** Row counter will register 1 row for every row of Fair Isle knitted. **All other machines** Row counter will register 2 rows for every row knitted.

Wax Wool.

## Welts and cuffs

**Ribber:** K. the number of rows given for 1 x 1 rib at T6/5. Transfer ribber sts. to M.B. for stocking stitch.

**Mock rib hem:** Using waste wool cast on number of sts. given. K. a few rows. Change to main colour. T8. K. twice the number of rows given. Make a hem. Unravel waste wool.

## SWEATER - BACK

Cast on 83 (89, 97, 103) sts. as 1 x 1 rib

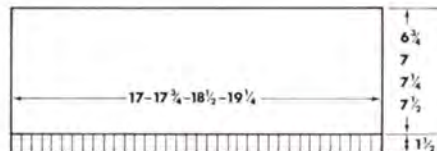
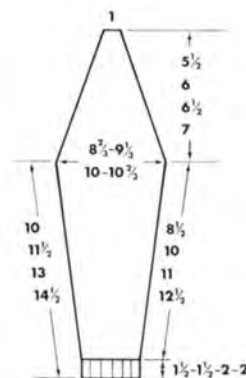
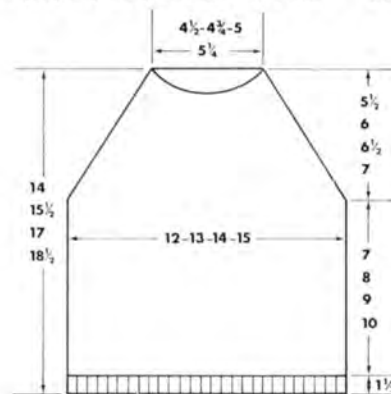

for Ribbers and 42 (45, 49, 52) alt. sts. for Mock Rib. (see Notes). K. 12 rows.

**All machines:** 000. T10. Foll. Fair Isle chart, k. 58 (66, 74, 82) rows. Adjust length here if required.

## Shape Raglan Armholes

000. Cast off 3 (3, 4, 4) sts. at beg. of next 2 rows. \* Dec. 1 st. at each end of next and every foll. alt. row until 37 (39, 41, 43) sts. remain, then on every row until 29 (31, 33, 35) sts. remain. Slip sts. on to a knitting needle.

## FRONT

K. as Back to \*. Dec. 1 st. at each end of next row and every foll. alt. row until 49 (53, 57, 61) sts. rem. K. 1 row. Using odd length of wool cast off 15 (17, 19, 21) sts. at centre. Push needles at Left to E position. H.C.L's II. K. the right side first. Continuing raglan dec. as before, k. 1 row. Dec. 1 st. at neck edge on next 4 rows then every alt. row until 4 (5, 6, 7) sts. remain. Keeping neck edge straight continue raglan shaping on alt. rows until 2 sts. remain. Cast off. H.C.L's I. Rejoin wool at centre and k. to match right side reversing all shapings.

## SLEEVES

Cast on 49 (51, 53, 55) sts. as 1 x 1 rib for Ribber and 25 (26, 27, 28) alt. sts. for Mock rib. (see notes). K. 12 (12, 16, 16) rows.

**All machines:** 000. T10. Foll. chart, k. 10 rows. Inc. 1 st. at each end of next and every foll. 10th row until there are 61 (65, 69, 78) sts. K. straight until 70 (82, 90, 102) rows have been worked. Adjust length here if required.

## Shape Raglan Top

Cast off 3 (3, 4, 4) sts. at beg. of next 2 rows. Dec. 1 st. at each end of next and every foll. alt. row until 13 (13, 9, 9) sts.







**The sociable sewing thread.  
Works happily with any fabric.**

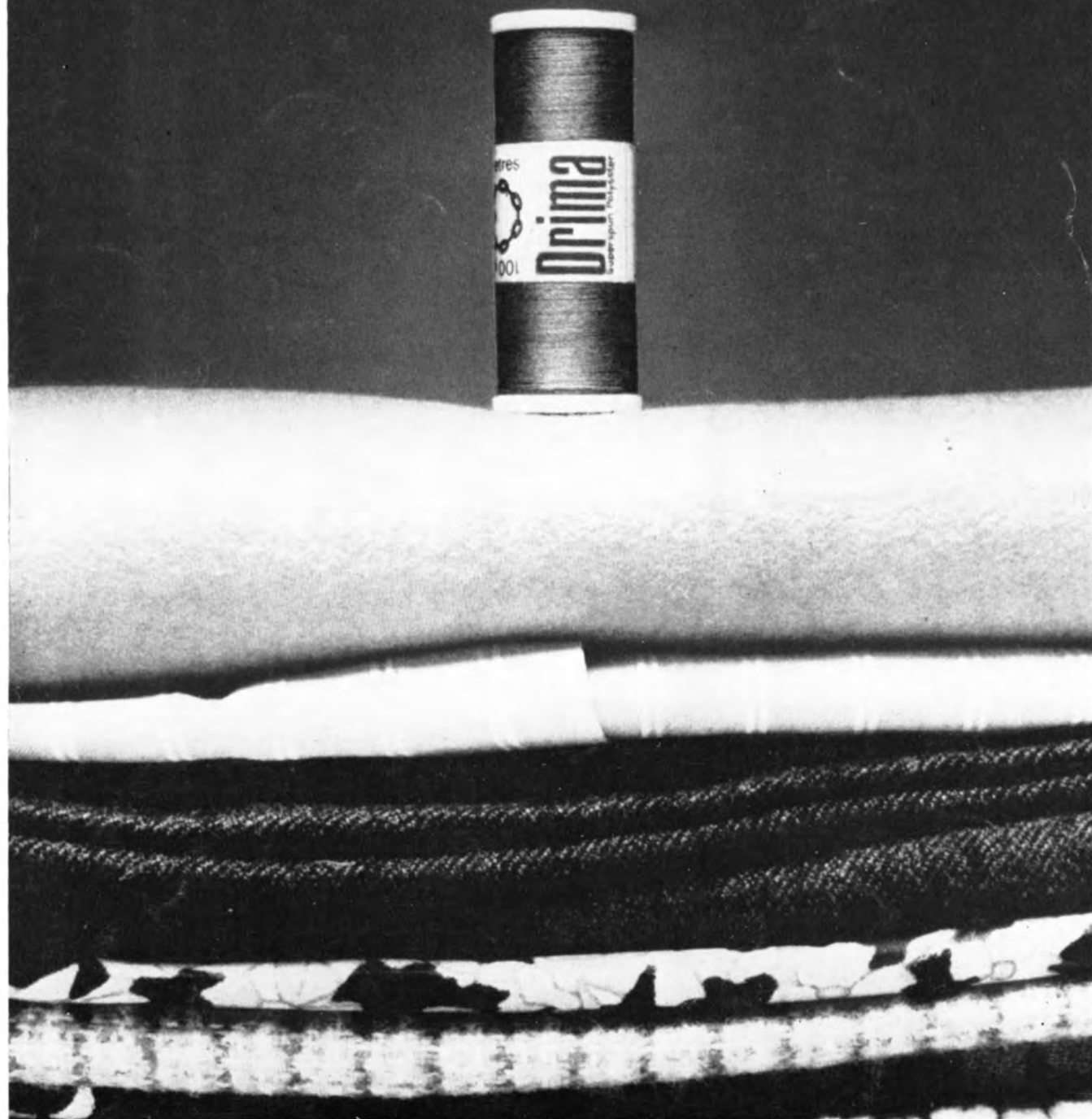

**Coats Drima** multi-purpose sewing thread—sews any material: heavy or light,  
natural or synthetic—by hand or machine. 100 yds on the compact spool.