

Empire-Knitmaster
MOD. 250

NEEDLE SELECTOR MANUAL

THE AUTOMATIC NEEDLE SELECTOR

You know already that different patterns can be knitted merely by changing the needles from 'B' to 'C' or 'D' position during knitting, by using the different Needle Pushers.

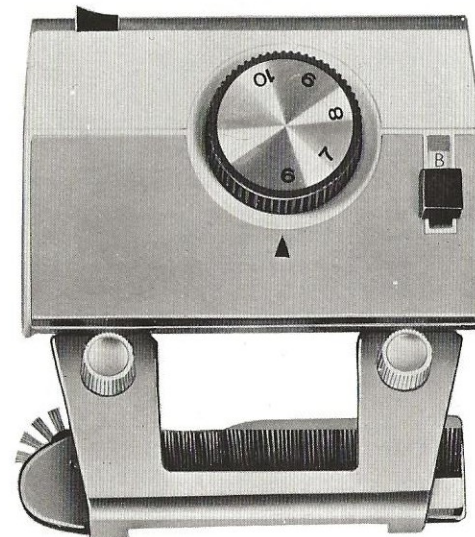

BUT, MUCH MORE QUICKLY AND IN A GREATER VARIETY OF COMBINATIONS, BY USING THIS AUTOMATIC NEEDLE SELECTOR.

The Needle Selector does NOT knit. It ONLY places the desired combination of needles in the correct position on the needle bed, ready for your carriage to knit.

This Needle Selector is quick, efficient and absolutely reliable - it is very simple to operate and after a few minutes practice you will become really expert at using it.

THE MAIN PARTS OF THE NEEDLE SELECTOR
AND THEIR FUNCTION

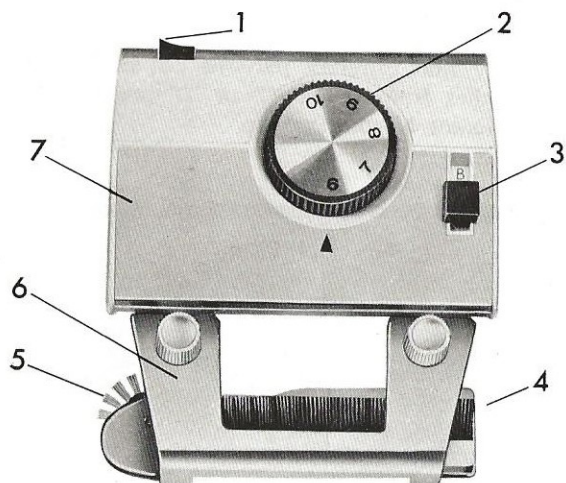

- 1. BACK LEVER
- 2. NUMBER DIAL
- 3. POSITION BUTTON

- 4. LATCH OPENING BRUSH
- 5. ROLLER BRUSH
- 6. SINKER ARM
- 7. CARRIAGE COVER

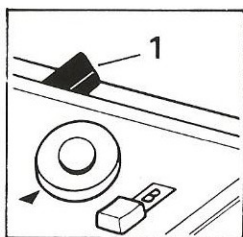

1. THE BACK LEVER.

If you wish to knit partial patterning in one of your garments, this is the LEVER to push IN at the place where you wish to STOP selecting the needles.

NOTE: If you wish to knit a centre panel in pattern, push IN the Lever right at the beginning of the row, release it when you wish to start selecting your needles, push it back IN about 2 needles before you wish to STOP selecting needles again.

THE MAIN PARTS OF THE NEEDLE SELECTOR (Continued)

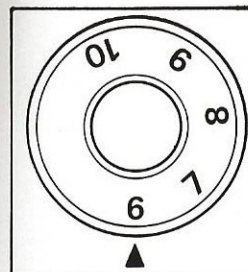

2. THE NUMBER DIAL.

Your Needle Selector can automatically select needles in combinations or groups of 6 to 12. The desired combination is set ready by hand over the first group and achieved over all needles by turning the Number Dial with the required number to the black indicator and sliding the Selector across the needles.

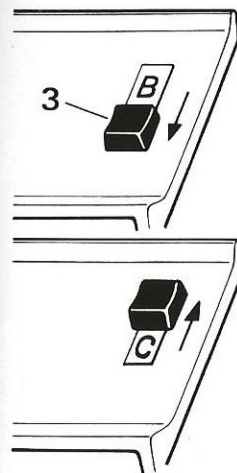

3. THE POSITION BUTTON.

It can be set to show B or C. If B shows through, the selected needles will automatically be raised from 'B' to 'D' position, the needles not selected remain in 'B' position.

If C shows through, which is ONLY for Fair Isle patterns, the selected needles for the second colour will be raised to 'C' position and the needles which knit the main colour will come up to 'D' position.

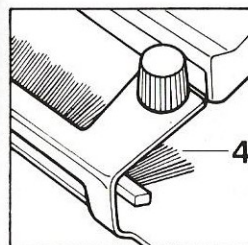

4. THE LATCH OPENING BRUSH.

This is very important when knitting Fair Isle patterns. The latches of the needles in 'C' position MUST be OPEN when you lay the yarn across the needles.

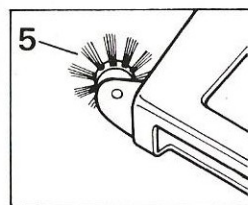

5. THE ROLLER BRUSH.

It holds the knitting safely back against the Sinker Gate while you slide the Needle Selector across the needle bed to select the required needles.

NOTE: The Needle Selector is assembled ready for use and has two main parts. The Sinker Arm is attached to the carriage.

HOW TO USE THE NEEDLE SELECTOR

I now show you a few practical examples to make these explanations easier to follow.

At the beginning, we will try a few examples without knitting - just with the empty needles. Later, when you feel confident, you may start knitting and enjoy the quick and easy needle settings using your Needle Selector.



PLEASE REMEMBER :

THE NEEDLE SELECTOR ONLY WORKS FROM THE RIGHT SIDE OF THE MACHINE TOWARDS THE LEFT SIDE.

YOU SHOULD ALWAYS PLACE THE NEEDLE SELECTOR ONTO THE NEEDLE BED AT THE RIGHT HAND SIDE OF THE NEEDLES IN KNITTING POSITION - BETWEEN THE KNITTING AND THE CARRIAGE.

HOW TO PLACE THE NEEDLE SELECTOR ON THE NEEDLE BED

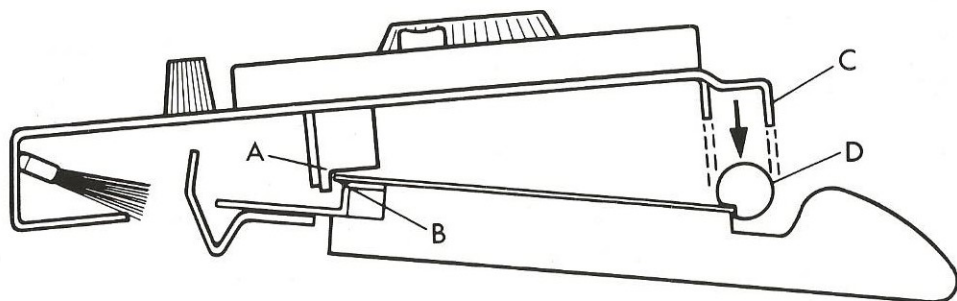

All needles are in 'A' position.

Always start to place the Selector onto the needle bed from the angle shown. The white nylon rail below the Selector must fit onto the front edge of the needle bed. Now lower the back of the Selector onto the needle bed so that the Back Guide 'G' fits over Rail 'R' of the needle bed.

The Selector should now move freely and smoothly across the needle bed towards the LEFT side of the machine - please try.

When the Selector is at the LEFT, remove it from the needle bed by first lifting up the Back Guide from the Rail and then remove the Selector towards you off the needle bed.

Practice, setting the Selector onto the needle bed at the RIGHT, sliding it across the needle bed towards the LEFT and removing it from the machine, until you repeat these movements easily and smoothly.

Now you can try this with some needles in 'B' position - but still without knitting in the needles.

1. The carriage is at the RIGHT.
2. Raise the centre 40 needles to 'B' position.
3. Push down both 'P' buttons on the carriage.

REMEMBER : The Selector ONLY works from RIGHT to LEFT.

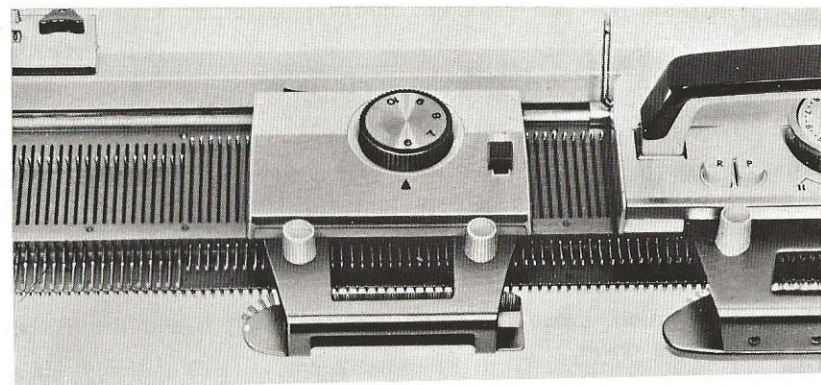

Place the Selector onto the needle bed BETWEEN the 40 needles in 'B' position and the carriage.

You are now ready to test your first needle selection and we will try it out on a group of 6 needles.

1. Turn the Number Dial on the Selector until 6 is at the indicator.
2. Move the Position Button to show B.
3. Leave the first 5 needles in 'B' position.
4. Push the 6th needle up to 'D' position.
5. Slide the Selector across the needles from RIGHT to LEFT, then remove it from the needle bed.

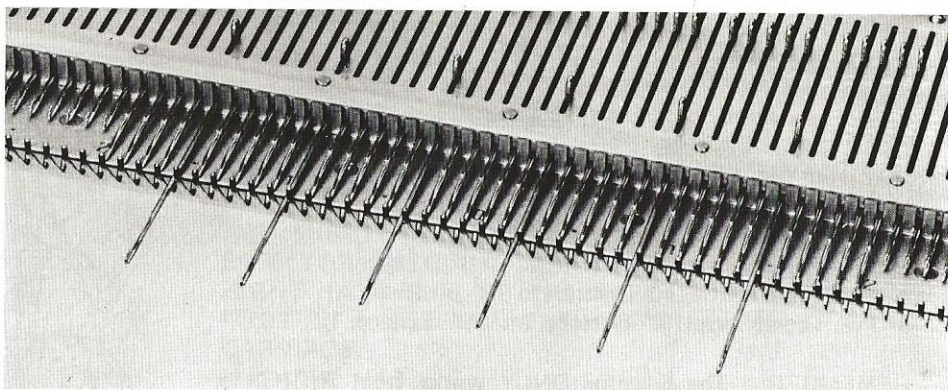

This is how your needles look now, 5 in 'B' and 1 in 'D' position right across all needles.

The 5 needles in 'B' and the 1 needle in 'D' position make a combination or a group of 6.

Move the carriage to the LEFT and you will automatically line up all needles in 'B' position, then move the carriage to the RIGHT, past the needles in knitting position.

Try the next selection. Leave the Selector setting as it is and the 'P' buttons on the carriage are down.

Leave the first 2 needles from the RIGHT in 'B' position, raise the third needle to 'D' position, again leave 2 needles in 'B' position and raise 1 needle to 'D' position.

Place the Selector onto the needle bed on the RIGHT side of the needles in knitting position and slide it across all 40 needles towards the LEFT.

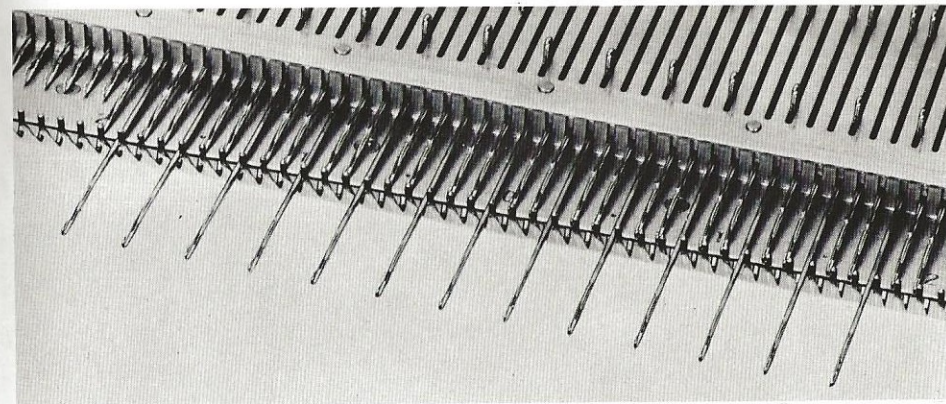

Now your needles look like this - every third needle has been raised to 'D' position.

2, 1, 2 and 1 needle make a group of 6 needles.

Move the carriage to the LEFT and back to the RIGHT to line up all needles in 'B' position.

If you wish to knit a pattern with every second needle - then move the 2nd, 4th and 6th needle up to 'D' position and leave the Number Dial on the Selector on 6.

Move the Selector across the needles towards the LEFT. Every SECOND needle is now raised to 'D' position. Move the carriage across to line up all needles in 'B' position.

LET'S MAKE ANOTHER TEST

Change the Number Dial on the Selector to 8. The carriage is at the RIGHT. All 40 needles are in 'B' position and the Selector is set between the carriage and the needles in knitting position.

Leave the first 7 needles in 'B' position and raise needle 8 to 'D' position. Slide the Selector towards the LEFT and remove it from the needle bed.

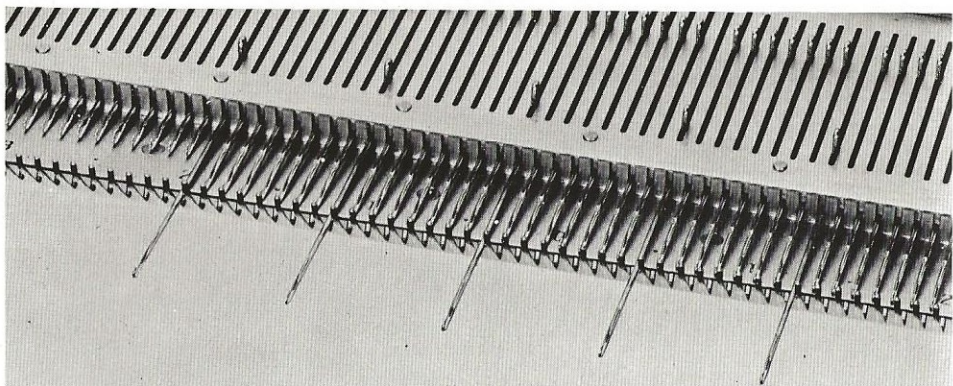

Now your needles look like this - every 8th needle has been raised to 'D' position.

7 and 1 make a group of 8 needles.

Move the carriage to the LEFT and back again to line up all needles in 'B' position.

If you would like to knit a pattern with every 4th needle - then move the 4th and 8th needle into 'D' position and leave the Number Dial on the Selector on 8. Slide the Selector across to the LEFT and every 4th needle will be raised to 'D' position. 3, 1, 3 and 1 make a group of 8 needles.

As you already know, when the Position Button shows C, the Needle Selector is ONLY used to set your needles for Fair Isle patterns. This means that you can knit TWO colours in ONE single row - this makes the knitting of Fair Isle patterns so quick and easy with your machine.

Let's try the first selection of needles for a Fair Isle pattern. The carriage is at the RIGHT and 40 needles are in 'B' position. Push down the buttons 'P' on the carriage and turn the Cam Lever to III on the RIGHT.

On the Selector, the Position Button shows C and the Number Dial is set to 10. Set the Selector between the carriage and the 40 needles in 'B' position.

Raise the first 5 needles from the RIGHT to 'D' position. Slide the Selector across the needles towards the LEFT, past the 40 needles, and remove it from the needle bed.

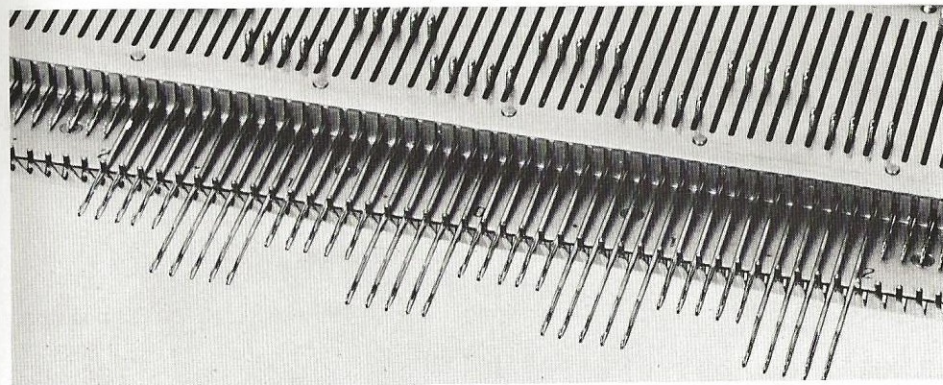

This is the needle setting which you have now. 5 in 'D' and 5 in 'C' position.

5 and 5 make a group of 10 needles.

The needles in 'D' position knit the yarn which comes from the Yarn Feeder and the needles in 'C' position knit the contrast colour which you lay across the needles by hand.

LET'S TRY THE FIRST PATTERN WITH THE SELECTOR.

Now it is time to start knitting your patterns with the Needle Selector. Make an open edge cast on over 40 needles and knit a few rows - finishing with the carriage at the RIGHT.

On the carriage, button 'P' on the LEFT is UP, button 'P' on the RIGHT is pushed down. The Cam Lever is set to the centre 0.

On the Selector, the Number Dial is set to 8 and the Position Button shows B.

First we will knit a TUCK stitch pattern with every 4th needle.

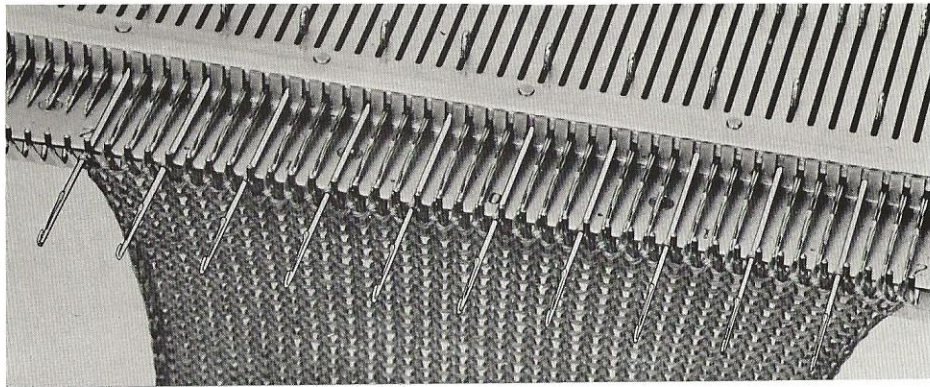

1. Bring the 4th and 8th needle from the RIGHT to 'D' position.
2. Slide the Selector across the knitting - every 4th needle is in 'D' position.
3. Knit 2 rows.

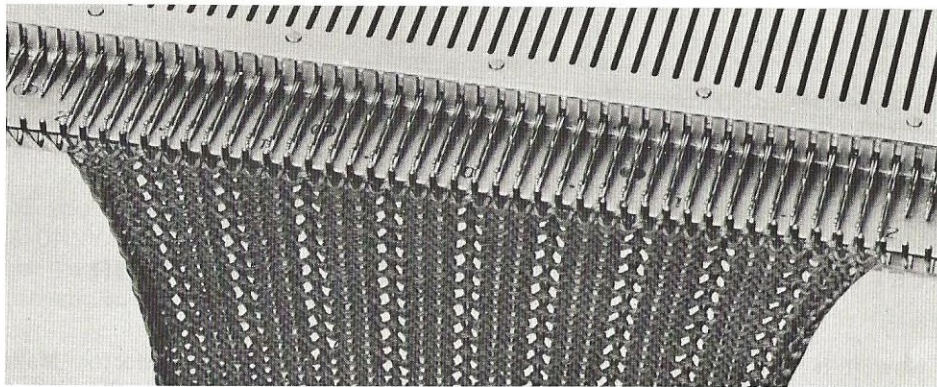

The carriage is at the RIGHT - move it away from the knitting in order to place the Selector between the knitting and the carriage.

Repeat 1 to 3 about 20 times - this how the pattern looks and I'm sure you are surprised how easily you knitted it.

NOW WE WILL TRY A ZIG-ZAG PATTERN IN SLIP STITCH.

Knit a few rows, finishing with the carriage at the RIGHT.
Both buttons 'P' are DOWN and the Cam Lever is set to II on the LEFT.
On the Selector - the Number Dial is set with 8 to the indicator and the Position Button shows B.

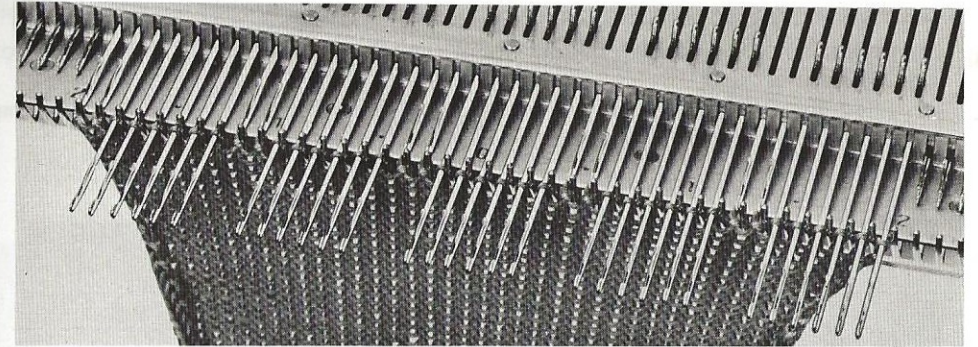

1. Bring the first 6 needles from the RIGHT up to 'D' position.
2. Slide the Selector across the needles to the LEFT. 6 needles are in 'D' and 2 are in 'B' position.
3. Knit 1 row.
The needles 7 and 8 have not been knitted and a thread is in front of these two stitches.

Now continue knitting while moving the pattern 1 stitch to the LEFT after each row of knitting. This Zig-Zag pattern is knitted over 16 rows and 8 stitches.

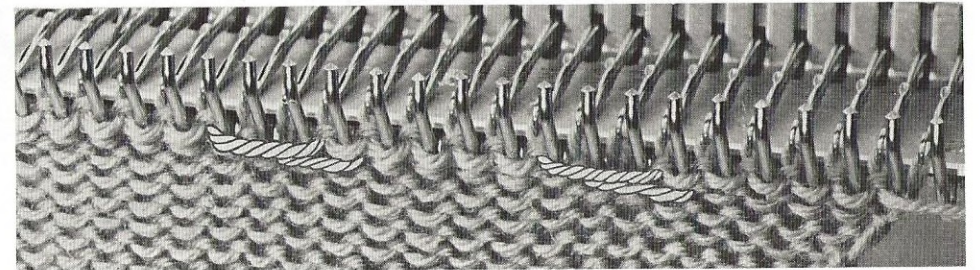

1. Leave the first needle from the RIGHT in 'B' and bring the next 6 needles up to 'D' position.
2. Slide the Selector across the needles. The first needle is in 'B' position, then 6 in 'D' and 2 in 'B' position again.
3. Knit 1 row.

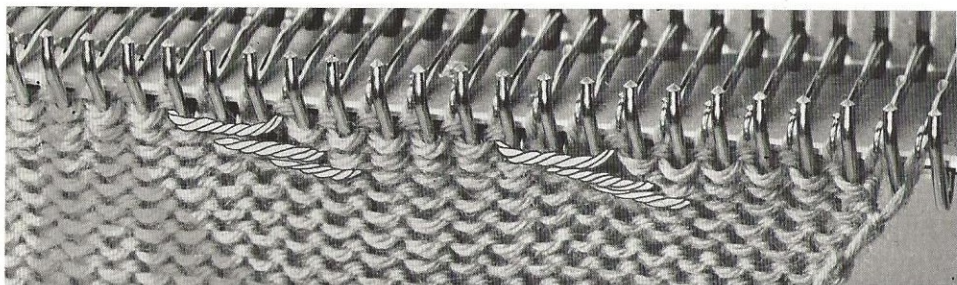

1. Leave 2 needles on the RIGHT in 'B' and bring the next 6 needles up to 'D' position.
2. Slide the Selector across the needles. The first 2 needles are in 'B' and the next 6 needles in 'D' position.
3. Knit 1 row.

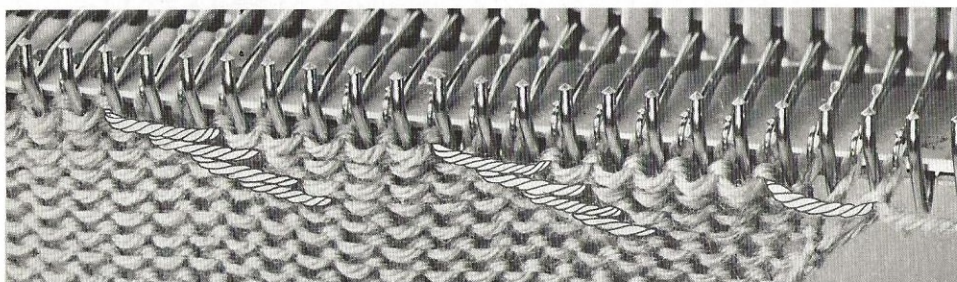

1. Bring the first needle from the RIGHT to 'D' and leave 2 in 'B', bring the next 5 needles up to 'D' position.
2. Slide the Selector across the needles. Except for the first needle, you have 2 needles in 'B' and 6 in 'D' position.
3. Knit 1 row.

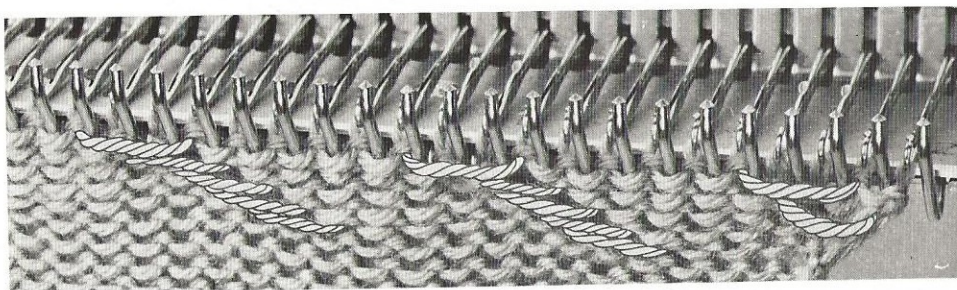

1. Move the first 2 needles from the RIGHT to 'D' position. Leave the next 2 in 'B' and bring the next 4 up to 'D' position.
2. Slide the Selector across the needles. Except for the two first needles from the RIGHT you have 2 needles in 'B' and 6 in 'D' position.
3. Knit 1 row.

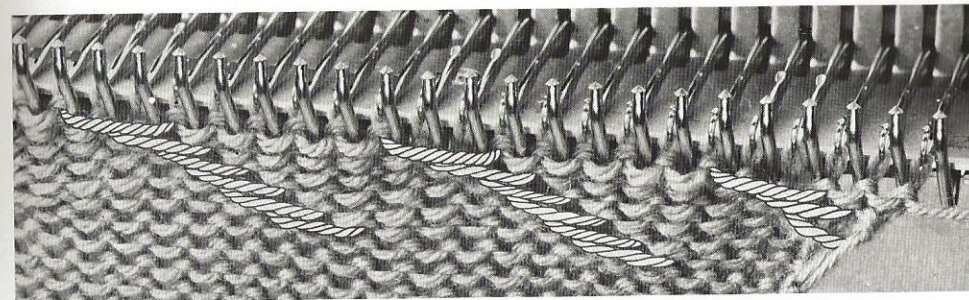

1. Bring the first 3 needles from the RIGHT to 'D', leave the next 2 in 'B', and bring the next 3 up to 'D' position.
2. Slide the Selector across the needles.
3. Knit 1 row.

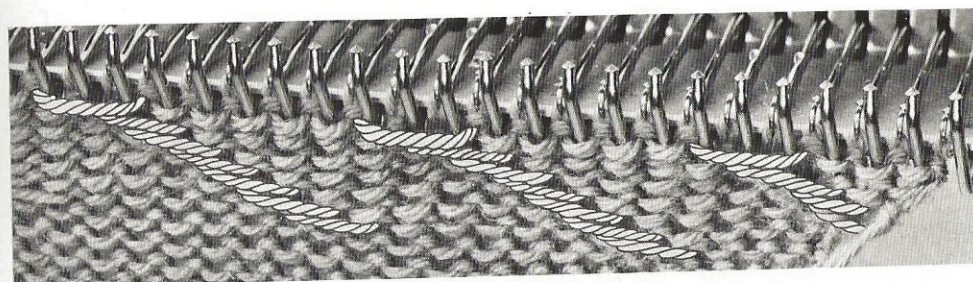

1. Bring the first 4 needles from the RIGHT to 'D' position, leave 2 in 'B', bring the next 2 up to 'D' position.
2. Slide the Selector across the needles.
3. Knit 1 row.

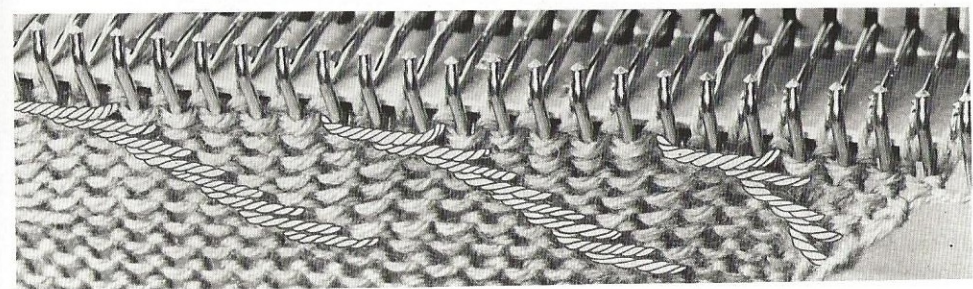

1. Bring the first 5 needles from the RIGHT to 'D' position. leave 2 in 'B', bring the next needle up to 'D' position.
2. Slide the Selector across the needles.
3. Knit 1 row.

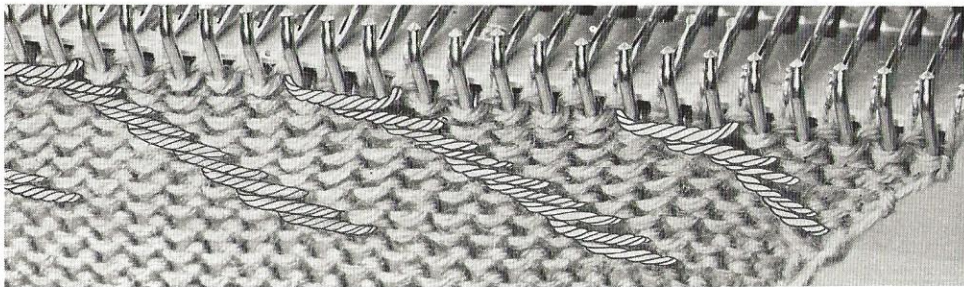

1. Bring the first 6 needles from the RIGHT to 'D' position, leave the next 2 in 'B' position.
2. Slide the Selector across the needles. You now have the same needle setting as in diagram 1.
3. Knit 1 row.

Your pattern has been moved 1 needle to the LEFT after each row.

Continue knitting the pattern BUT first setting 8, then 7, 6, 5, 4, 3 and 2. After setting 2 you may start with setting 1 again and this way continue knitting the Zig-Zag pattern.

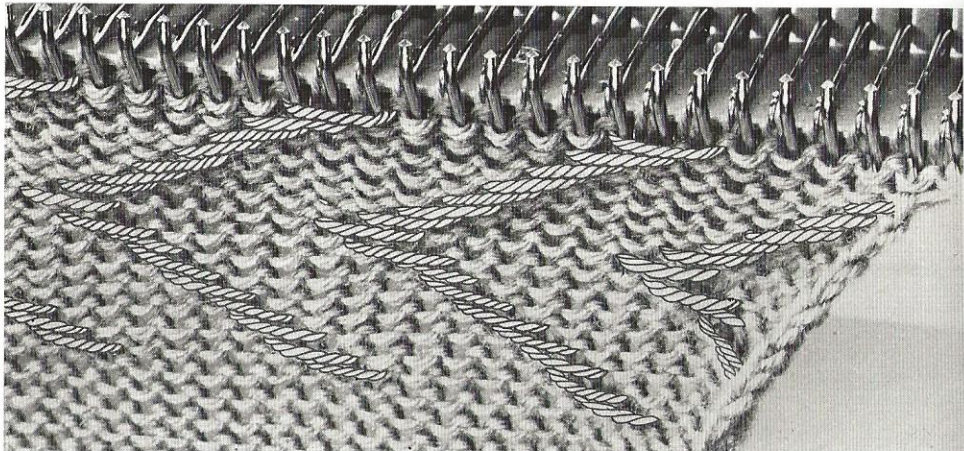

Here is how your pattern should look if it has been knitted as given in the instructions.

Slip Stitch Patterns can be knitted with nearly every type of yarn but as this pattern pulls the knitting slightly, it is recommended that you use a Tension 1 or 2 points looser than normal.

PATTERNING - GENERAL HINTS



The pattern possibilities of your knitting machine are almost limitless. Pattern knitting is, of course, slower than plain stocking stitch, but so interesting and the results so fascinating, that you will find the time spent most rewarding.

There are two very important points to keep in mind when knitting patterns.

1. The MOST important point is that your Tension setting MUST be correct for the yarn you are using.
2. The yarn MUST be suitable for the type of pattern you have selected.

It is recommended, particularly when you are not yet accustomed to pattern making, that you keep to light weight yarns which can be knitted on Tension 5 and lower.

The pattern book contains 50 diagrams divided in 3 groups.

1. The first 20 patterns are TUCK and SLIP stitch patterns - all knitted with one colour only.
2. Then comes a group of 21 FAIR ISLE patterns and of course, the knitting instructions.
3. Lastly I show you how to knit wonderful LACE patterns WITHOUT TRANSFERRING STITCHES. Just with simple and easy needle settings.



THE PATTERN DIAGRAMS ARE EASY TO FOLLOW.

The pattern diagrams are set out in simple and easy to follow columns. In order to explain how to read them, I have divided the diagram below into 8 main groups.

At the top of each pattern diagram, in the RIGHT hand corner you will find a diagram indicating the Needle Selector setting.

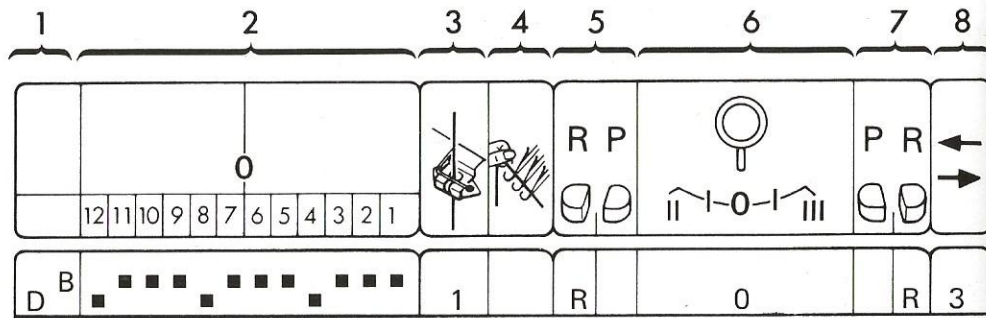

1. The NEEDLE POSITION. This means the position on the needle bed into which the selected needles must be pushed BEFORE knitting the first pattern row.
2. This shows you a group of 12 needles beginning from the RIGHT side of the knitting.

ALWAYS START TO SELECT NEEDLES FROM THE RIGHT HAND SIDE.

ALWAYS START TO KNIT THE FIRST PATTERN WITH THE CARRIAGE ON THE RIGHT HAND SIDE OF THE MACHINE.

In the above diagram ALL needles are in 'B' position except the 4th, 8th and 12th which are in 'D' position.

It is not necessary to push up these needles, just bring the 4th and 8th needle to 'D' position, set the Number Dial on the Selector to 8 and the Position Button to show B and slide the Selector across the needles in Knitting position.

Every 4th needle comes out automatically to 'D' position.

Later, when you are more familiar with your Needle Selector, you can make your own needle combinations thereby giving yourself a much wider range of patterns.

3. This column is for the yarn which you will knit through the Yarn Feeder.

As long as you knit with one colour, the number 1 will be shown in this column. When you have to change to a second colour, then you have a 2 in place of the 1.

Sometimes you even see 1, 2 and 3 - this means you knit with 3 different colour yarns.

4. This column is ONLY used when you knit Fair Isle patterns. I show you how to knit them later in this book.
5. On the LEFT side of the carriage are two buttons marked R and P.

This column shows you which button you have to push DOWN before you knit the next row. Button R releases button P.

6. In the centre of the carriage is the Cam Lever - you can turn it to 5 different positions.

The centre 0 is for plain knitting and the two positions on the LEFT and RIGHT are for patterns.

In this column we show in which position the Cam Lever must be set before you knit the next row.

7. On the RIGHT side of the carriage are two buttons marked R and P.

This column shows you which button you have to push DOWN before you knit the next row. Button R releases button P.

8. This column shows you the number of rows which you should knit with the actual pattern setting.

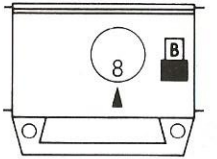
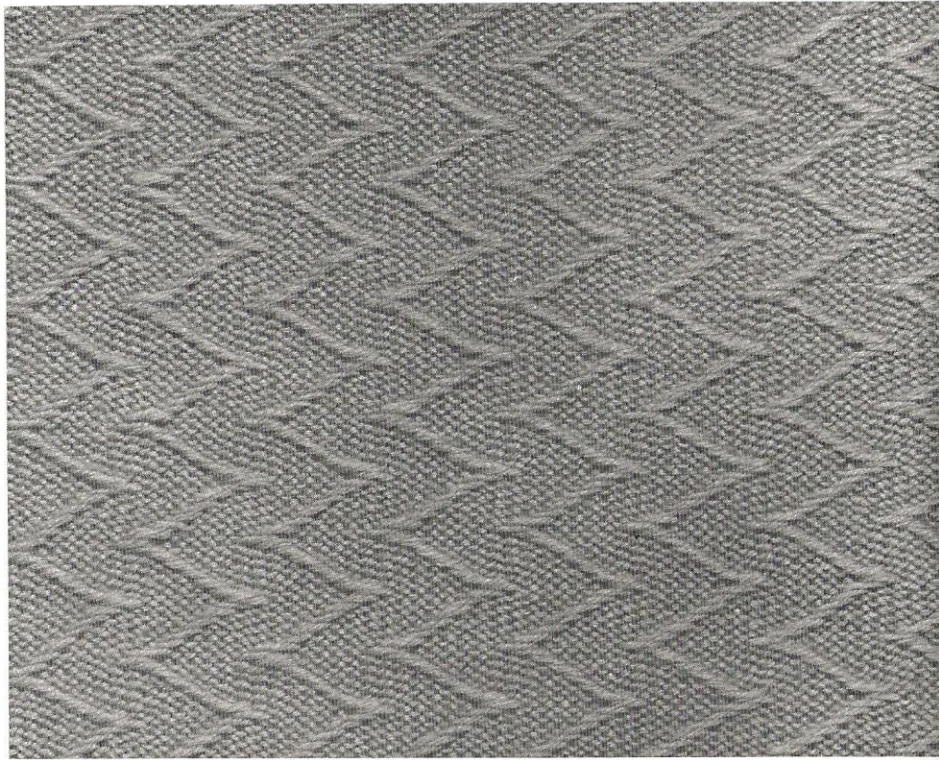

		0												R P		P R										
		12	11	10	9	8	7	6	5	4	3	2	1					II	I	0	I	III				
D	B	■	■	■	■	■	■	■	■	■	■	■	■	1		P	II					P			1	
D	B	■	■	■	■	■	■	■	■	■	■	■	■	"		"	"					"		"	"	
D	B	■	■	■	■	■	■	■	■	■	■	■	■	"		"	"					"		"	"	
D	B	■	■	■	■	■	■	■	■	■	■	■	■	"		"	"					"		"	"	
D	B	■	■	■	■	■	■	■	■	■	■	■	■	"		"	"					"		"	"	
D	B	■	■	■	■	■	■	■	■	■	■	■	■	"		"	"					"		"	"	
D	B	■	■	■	■	■	■	■	■	■	■	■	■	"		"	"					"		"	"	
D	B	■	■	■	■	■	■	■	■	■	■	■	■	"		"	"					"		"	"	
D	B	■	■	■	■	■	■	■	■	■	■	■	■	"		"	"					"		"	"	
D	B	■	■	■	■	■	■	■	■	■	■	■	■	"		"	"					"		"	"	
D	B	■	■	■	■	■	■	■	■	■	■	■	■	"		"	"					"		"	"	
D	B	■	■	■	■	■	■	■	■	■	■	■	■	"		"	"					"		"	"	
D	B	■	■	■	■	■	■	■	■	■	■	■	■	"		"	"					"		"	"	

302

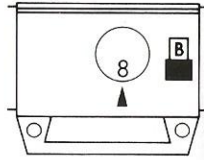

0													R P		P R	
12	11	10	9	8	7	6	5	4	3	2	1					
D B	■	■	■	■	■	■	■	■	■	■	■	1	R	0		R 3
												"	"	"	P	1
D B	■	■	■	■	■	■	■	■	■	■	■	"	"	"		R 3
												"	"	"	P	1
D B	■	■	■	■	■	■	■	■	■	■	■	"	"	"		R 3
												"	"	"	P	1
D B	■	■	■	■	■	■	■	■	■	■	■	"	"	"		R 3
												"	"	"	P	1

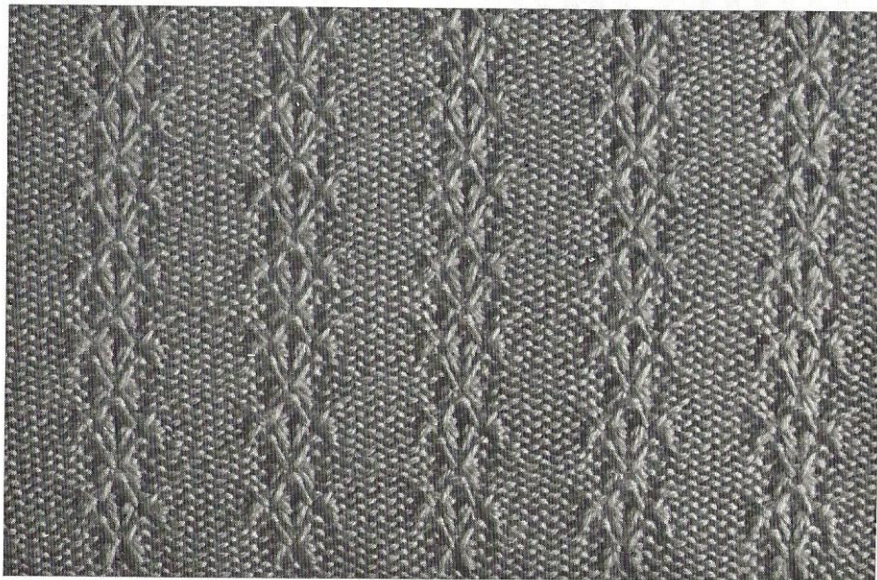

216

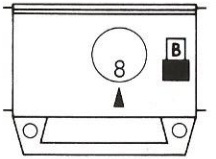

0													R P		P R	
12	11	10	9	8	7	6	5	4	3	2	1					
D B	■	■	■	■	■	■	■	■	■	■	■	1	R	0		R 3
												"	"	"	P	1
D B	■	■	■	■	■	■	■	■	■	■	■	"	"	"		R 3
												"	"	"	P	1
D B	■	■	■	■	■	■	■	■	■	■	■	"	"	"		R 3
												"	"	"	P	1
D B	■	■	■	■	■	■	■	■	■	■	■	"	"	"		R 3
												"	"	"	P	1

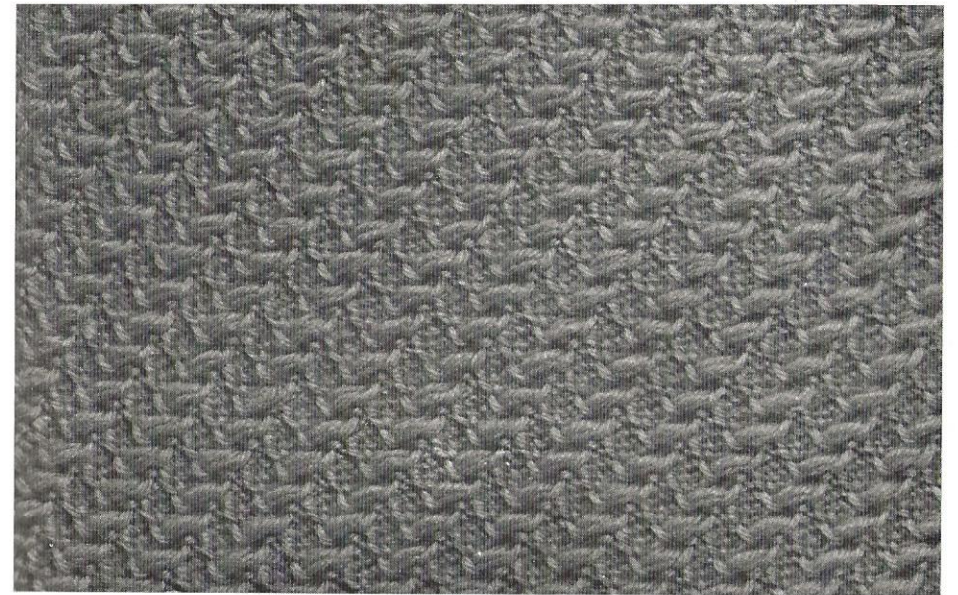

340

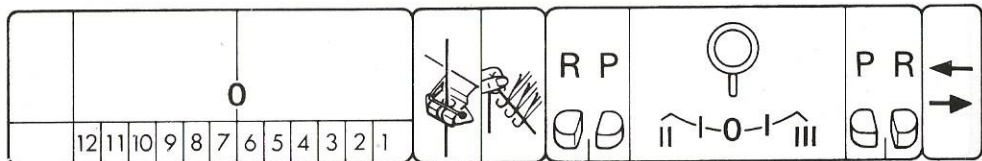
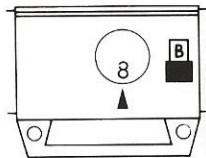

D B		1	R	0		R	2
		"		P	"	"	1
D B		"	R	"		"	2
		"	"	"	P		1
D B		"	"	"		R	2
		"		P	"	"	1
D B		"	R	"		"	2
		"	"	"	P		1

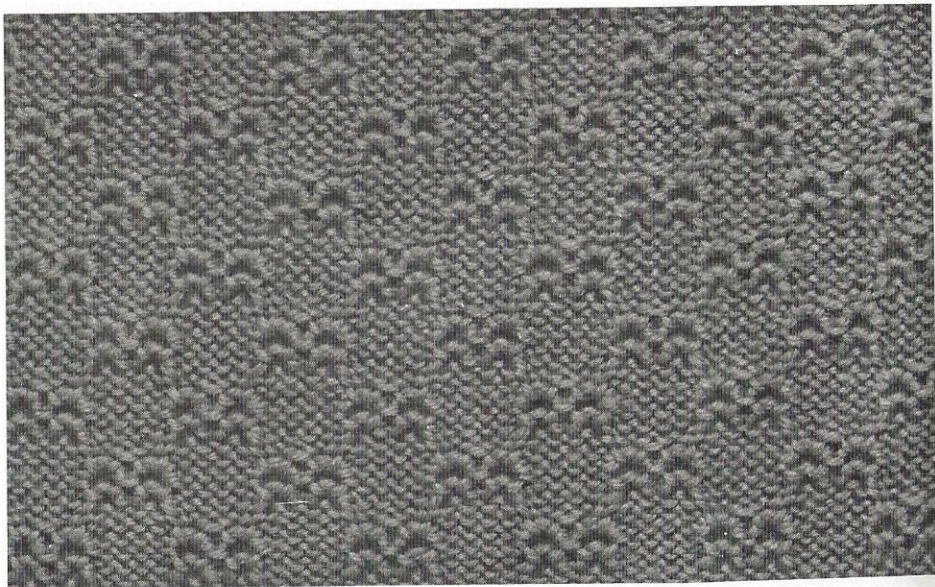

5009

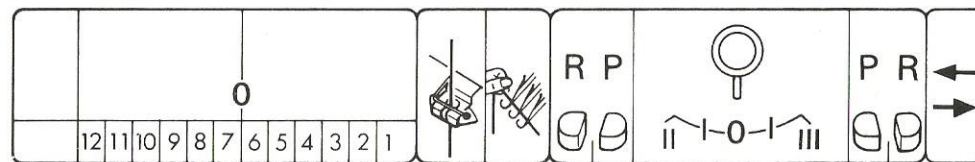
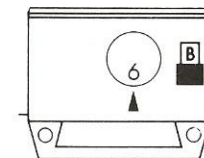

D B		1	R	0		R	3
		"	"	"	P		1
D B		"	"	"		R	3
		"	"	"	P		1

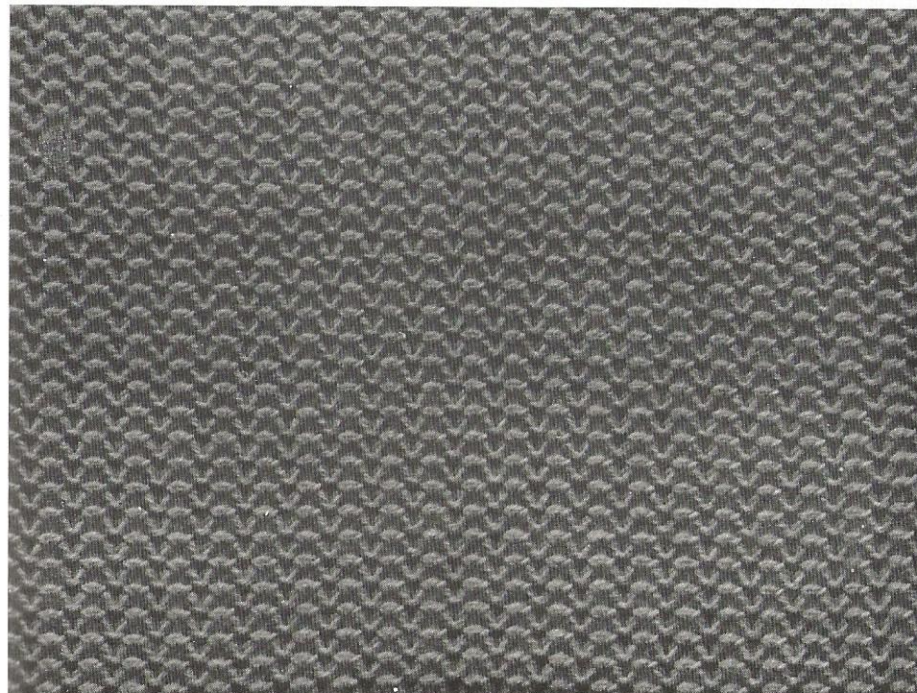

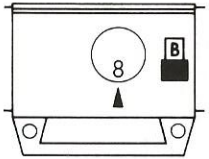
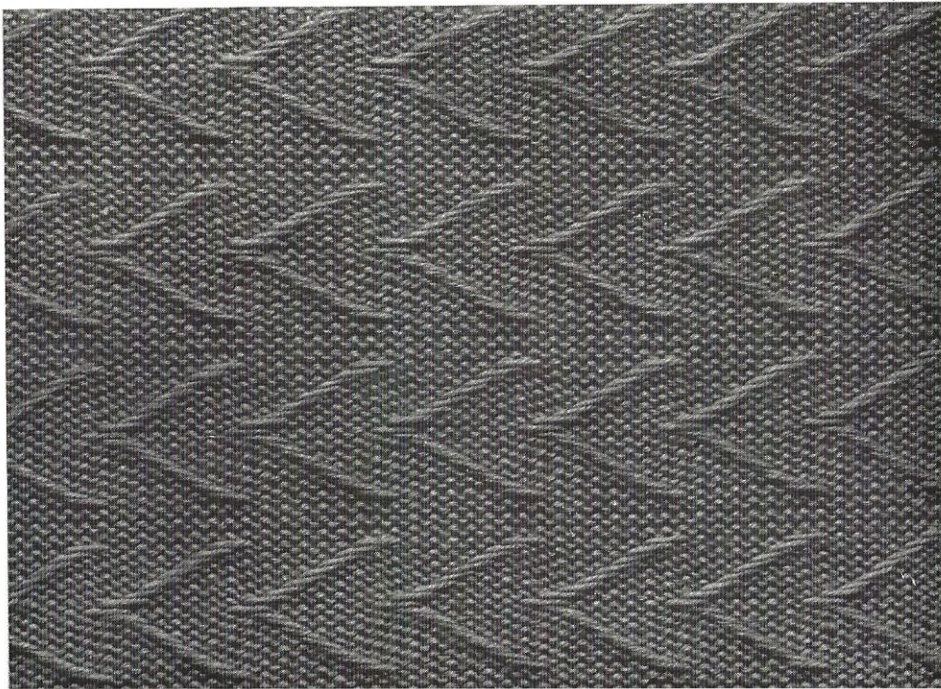

0														R P				P R			
12	11	10	9	8	7	6	5	4	3	2	1										
D	B											1				P	II			P	1
D	B											"		"	"			"	"		
D	B											"		"	"			"	"		
D	B											"		"	"			"	"		
D	B											"		"	"			"	"		
D	B											"		"	"			"	"		
D	B											"		"	"			"	"		
D	B											"		"	"			"	"		
D	B											"		"	"			"	"		
D	B											"		"	"			"	"		
D	B											"		"	"			"	"		
D	B											"		"	"			"	"		
D	B											"		"	"			"	"		
												"		"		0		"		"	2

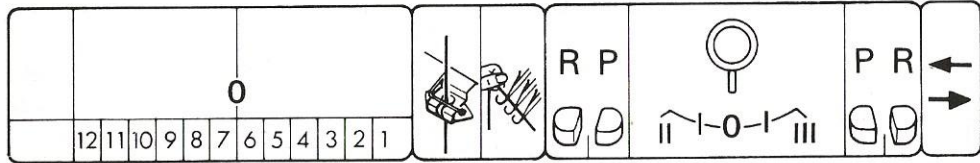
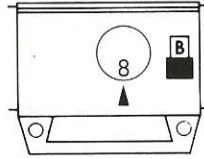

D B		1		P	II	P	1
D B		"		"	"	"	"
D B		"		"	"	"	"
D B		"		"	"	"	"
D B		"		"	"	"	"
D B		"		"	"	"	"
D B		"		"	"	"	"
D B		"		"	"	"	"

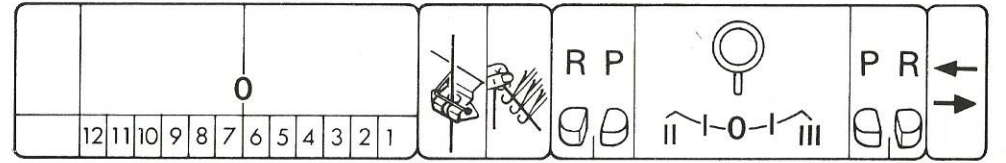
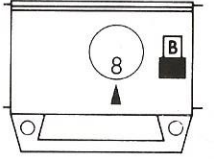

B		1		P	0	P	6
D B		"		"	II	"	1
D B		"		"	"	"	"
D B		"		"	"	"	"
D B		"		"	"	"	"
D B		"		"	"	"	"
D B		"		"	"	"	"
D B		"		"	"	"	"
D B		"		"	"	"	"
D B		"		"	"	"	"



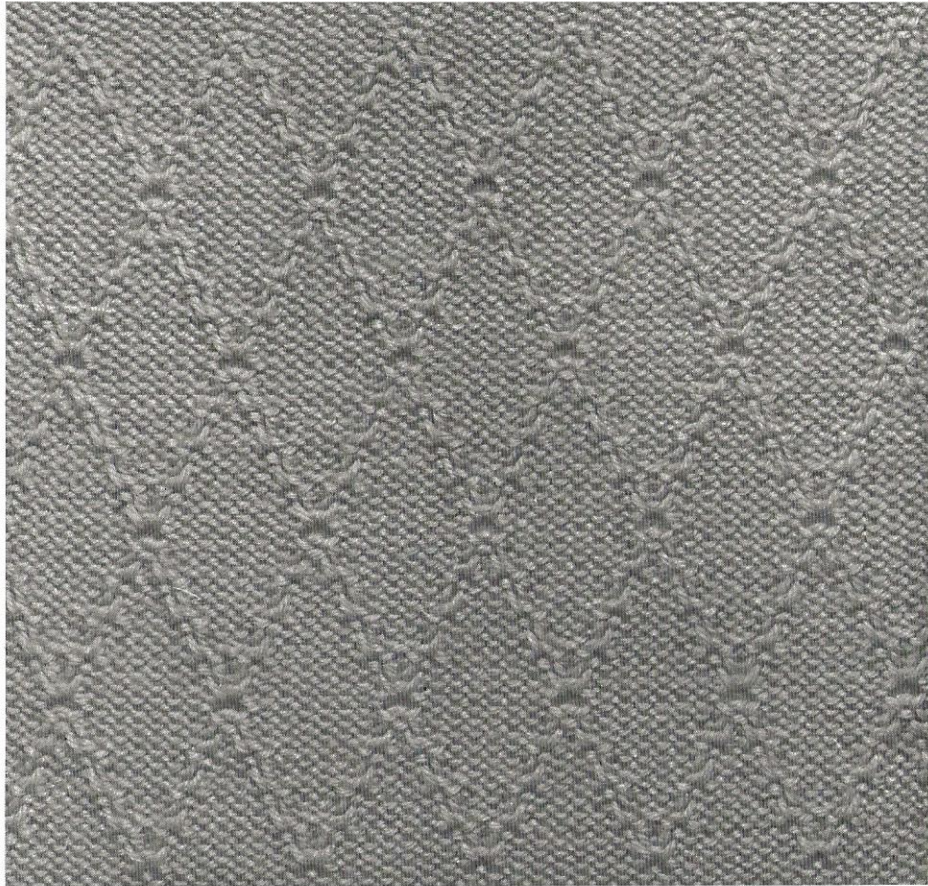

342

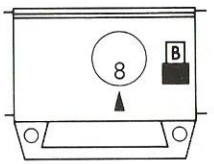

0														R P				P R			
12	11	10	9	8	7	6	5	4	3	2	1										
D	B	■	■	■	■	■	■	■	■	■	■	1		R			0		R	2	
												"			P		"		"	1	
D	B	■	■	■	■	■	■	■	■	■	■	"		R			"		"	2	
												"		"			"	P		1	
D	B	■	■	■	■	■	■	■	■	■	■	"		"			"		R	2	
												"			P		"		"	1	
D	B	■	■	■	■	■	■	■	■	■	■	"		R			"		"	2	
												"		"			"	P		1	
D	B	■	■	■	■	■	■	■	■	■	■	"		"			"		R	2	
												"			P		"		"	1	
D	B	■	■	■	■	■	■	■	■	■	■	"		R			"		"	2	
												"		"			"	P		1	
D	B	■	■	■	■	■	■	■	■	■	■	"		"			"		R	2	
												"			P		"		"	1	
D	B	■	■	■	■	■	■	■	■	■	■	"		R			"		"	2	
												"		"			"	P		1	

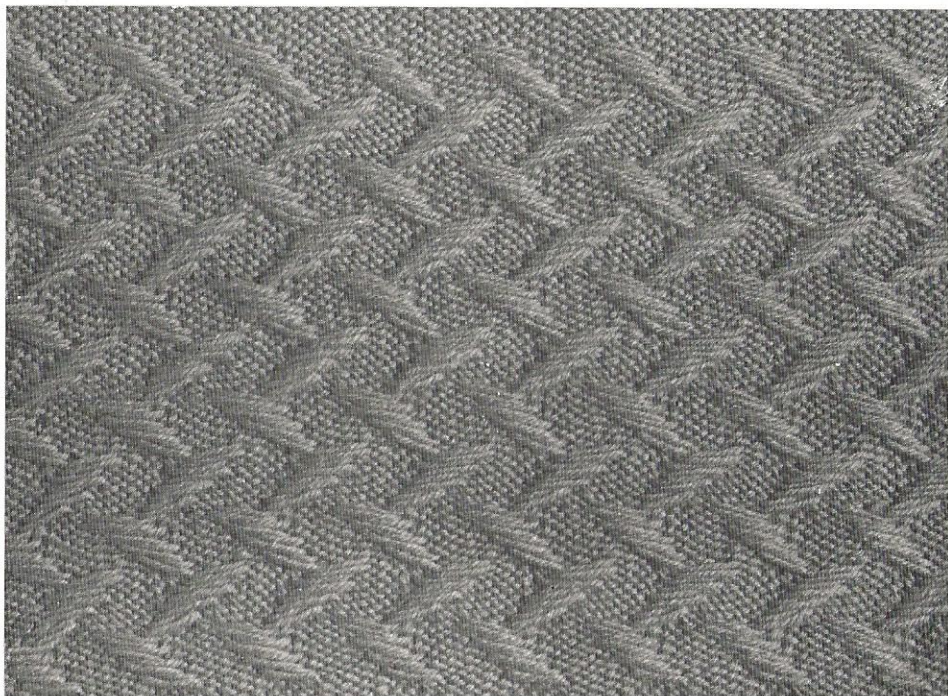

436

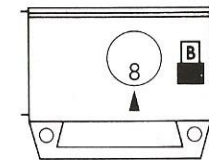

		0											RP		PR							
		12	11	10	9	8	7	6	5	4	3	2	1			II	I	0	I	III		
D	B	■	■	■	■	■	■	■	■	■	■	■	■	1		P	II			P	1	
D	B	■	■	■	■	■	■	■	■	■	■	■	■	"		"	"			"	"	
D	B	■	■	■	■	■	■	■	■	■	■	■	■	"		"	"			"	"	
D	B	■	■	■	■	■	■	■	■	■	■	■	■	"		"	"			"	"	
D	B	■	■	■	■	■	■	■	■	■	■	■	■	"		"	"			"	"	
D	B	■	■	■	■	■	■	■	■	■	■	■	■	"		"	"			"	"	
D	B	■	■	■	■	■	■	■	■	■	■	■	■	"		"	"			"	"	
D	B	■	■	■	■	■	■	■	■	■	■	■	■	"		"	"			"	"	
D	B	■	■	■	■	■	■	■	■	■	■	■	■	"		"	"			"	"	
D	B	■	■	■	■	■	■	■	■	■	■	■	■	"		"	"			"	"	
D	B	■	■	■	■	■	■	■	■	■	■	■	■	"		"	"			"	"	
D	B	■	■	■	■	■	■	■	■	■	■	■	■	"		"	"			"	"	
D	B	■	■	■	■	■	■	■	■	■	■	■	■	"		"	"			"	"	
D	B	■	■	■	■	■	■	■	■	■	■	■	■	"		"	"			"	"	
D	B	■	■	■	■	■	■	■	■	■	■	■	■	"		"	"			"	"	
D	B	■	■	■	■	■	■	■	■	■	■	■	■	"		"	"			"	"	

452

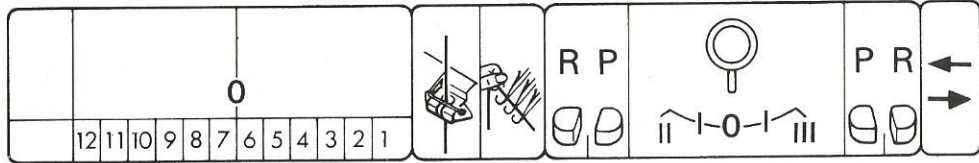
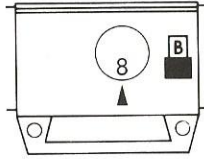

D B		1		P	II		P	1
D B		"		"	"		"	"
D B		"		"	"		"	"
D B		"		"	"		"	"
D B		"		"	"		"	"
D B		"		"	"		"	"
D B		"		"	"		"	"
D B		"		"	"		"	"
D B		"		"	"		"	"
D B		"		"	"		"	"
D B		"		"	"		"	"
D B		"		"	"		"	"

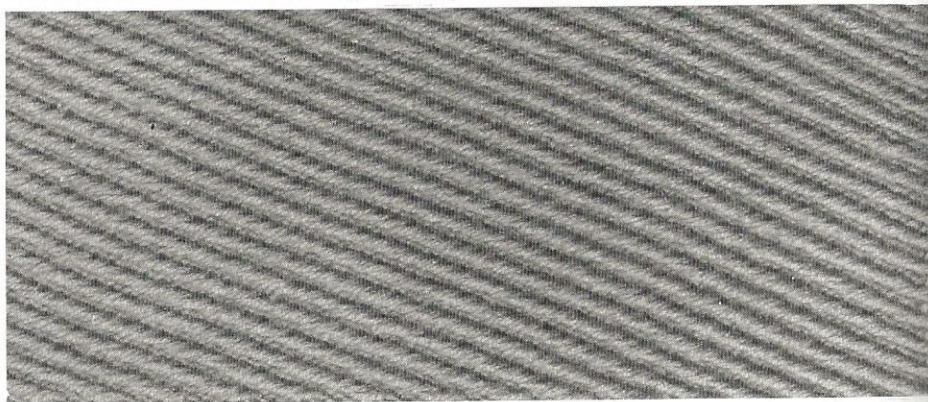

5018

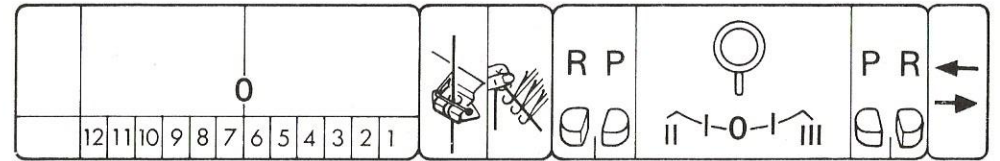
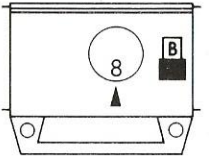

D B		1		R		0		R	1
		"		"		"		P	"
D B		"		"		"		R	"
		"		"		"		P	"

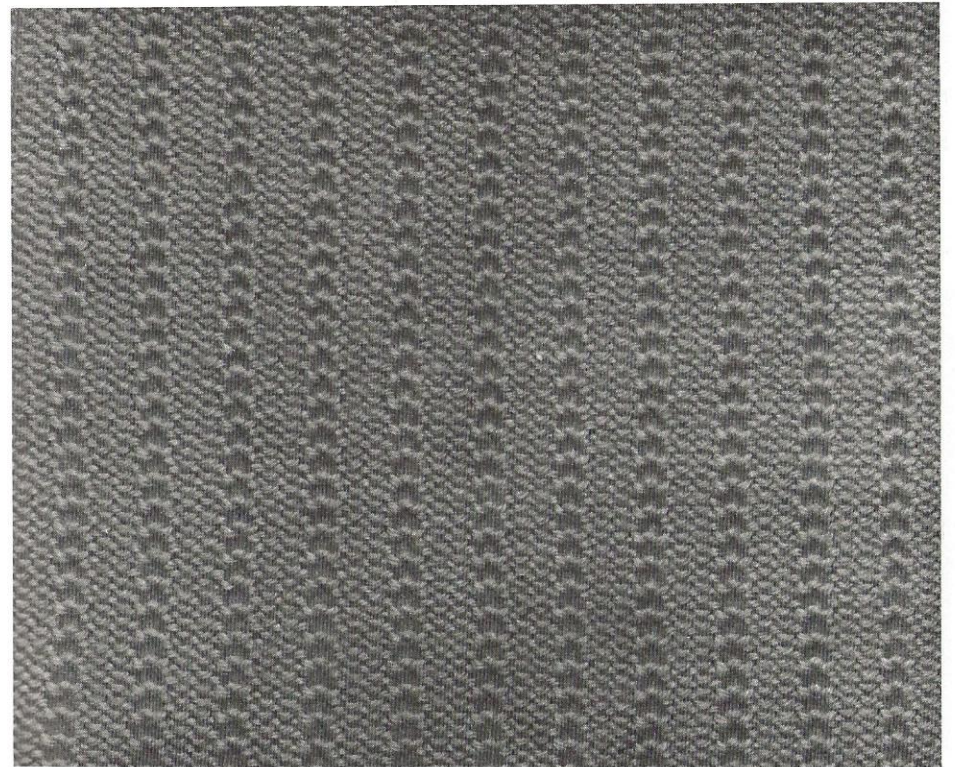

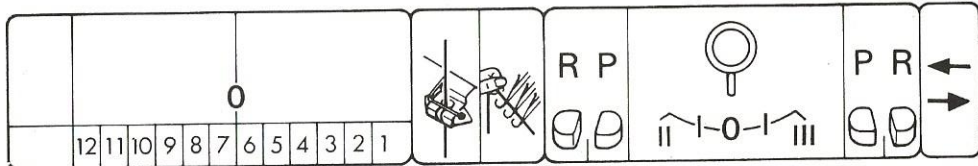
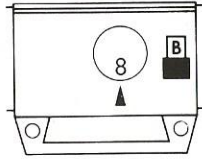

D B		1		P		P		1
D B		"		"	"	"		"
D B		"		"	"	"		"
D B		"		"	"	"		"
D B		"		"	"	"		"
D B		"		"	"	"		"
D B		"		"	"	"		"
D B		"		"	"	"		"

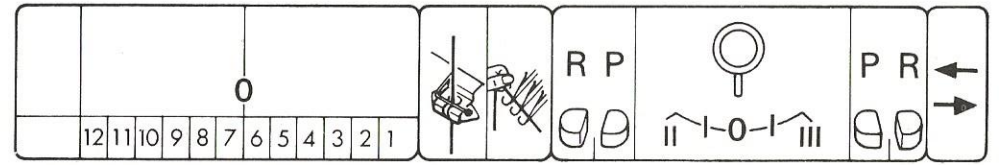
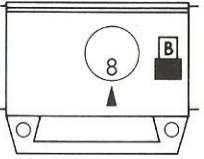
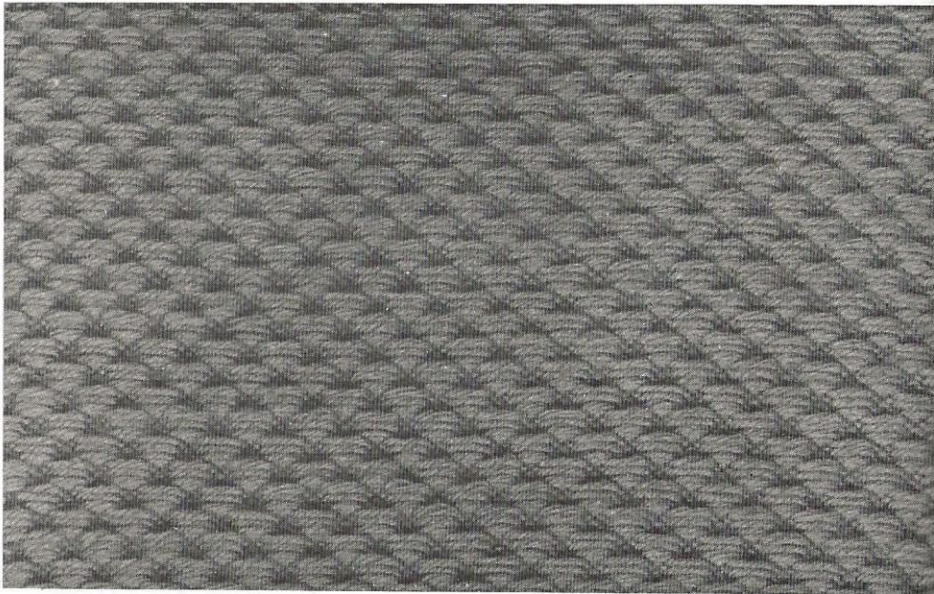

B		1		P	0	P		2
D B		"		"		"		1
D B		"		"	"	"		"
D B		"		"	"	"		"
D B		"		"	"	"		"
B		"		"	0	"		2
D B		"		"		"		1
D B		"		"	"	"		"
D B		"		"	"	"		"
D B		"		"	"	"		"

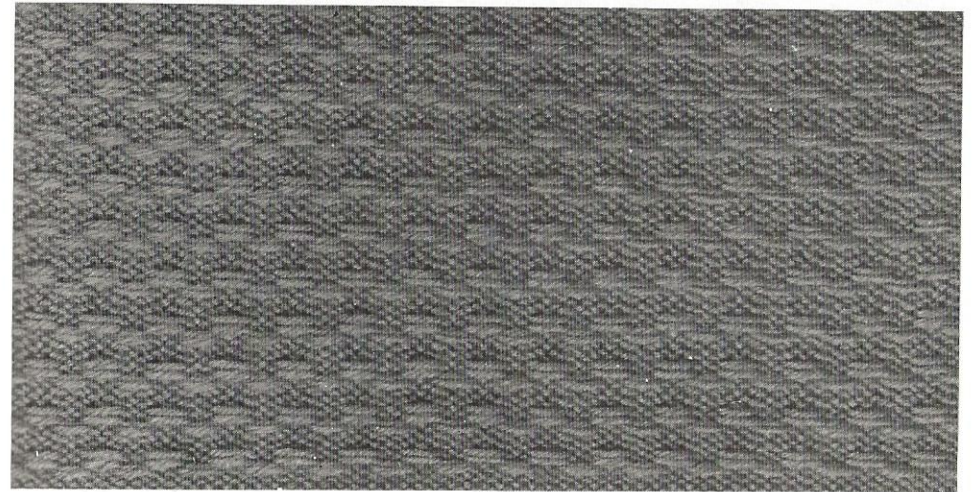

5030

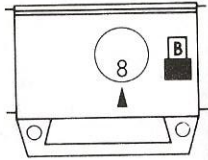

0													R P		P R ←	P R →
12	11	10	9	8	7	6	5	4	3	2	1					
D B												1	R	0	R	3
												"	"	"	P	1
D B												"	"	"	R	3
												"	"	"	P	1

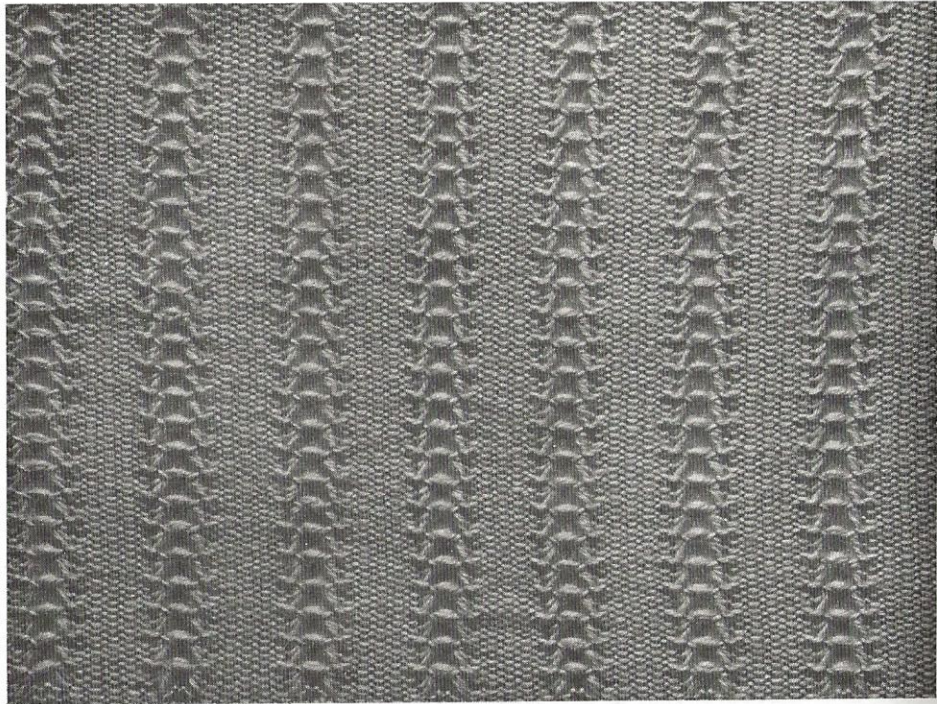

5027

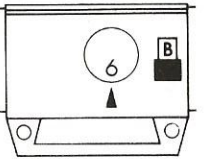

0													R P		P R ←	P R →
12	11	10	9	8	7	6	5	4	3	2	1					
D B												1	R	0	R	3
												"	"	"	P	1
D B												"	"	"	R	3
												"	"	"	P	1



5028

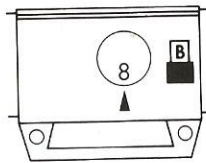

0														R P				P R		← →	
D	B	■	■	■	■	■	■	■	■	■	■	1		R				0		R	3
												"		"				"		P	1
D	B	■	■	■	■	■	■	■	■	■	■	"		"				"		R	3
												"		"				"		P	1
D	B	■	■	■	■	■	■	■	■	■	■	"		"				"		R	3
												"		"				"		P	1
D	B	■	■	■	■	■	■	■	■	■	■	"		"				"		R	3
												"		"				"		P	1
D	B	■	■	■	■	■	■	■	■	■	■	"		"				"		R	3
												"		"				"		P	1

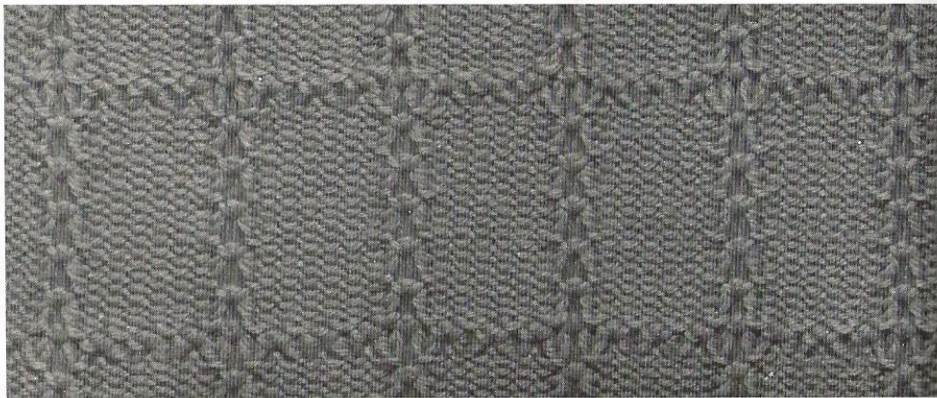

515

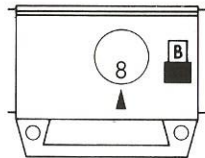

0														R P				P R		← →	
D	B	■	■	■	■	■	■	■	■	■	■	1		R				0		R	3
												"		"				"		P	1
D	B	■	■	■	■	■	■	■	■	■	■	"		"				"		R	3
												"		"				"		P	1
D	B	■	■	■	■	■	■	■	■	■	■	"		"				"		R	3
												"		"				"		P	1
D	B	■	■	■	■	■	■	■	■	■	■	"		"				"		R	3
												"		"				"		P	1
D	B	■	■	■	■	■	■	■	■	■	■	"		"				"		R	3
												"		"				"		P	1

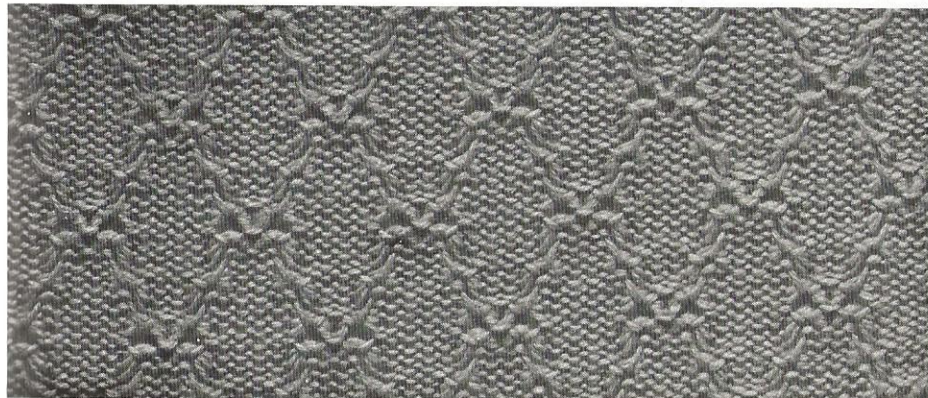

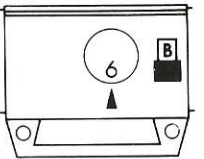
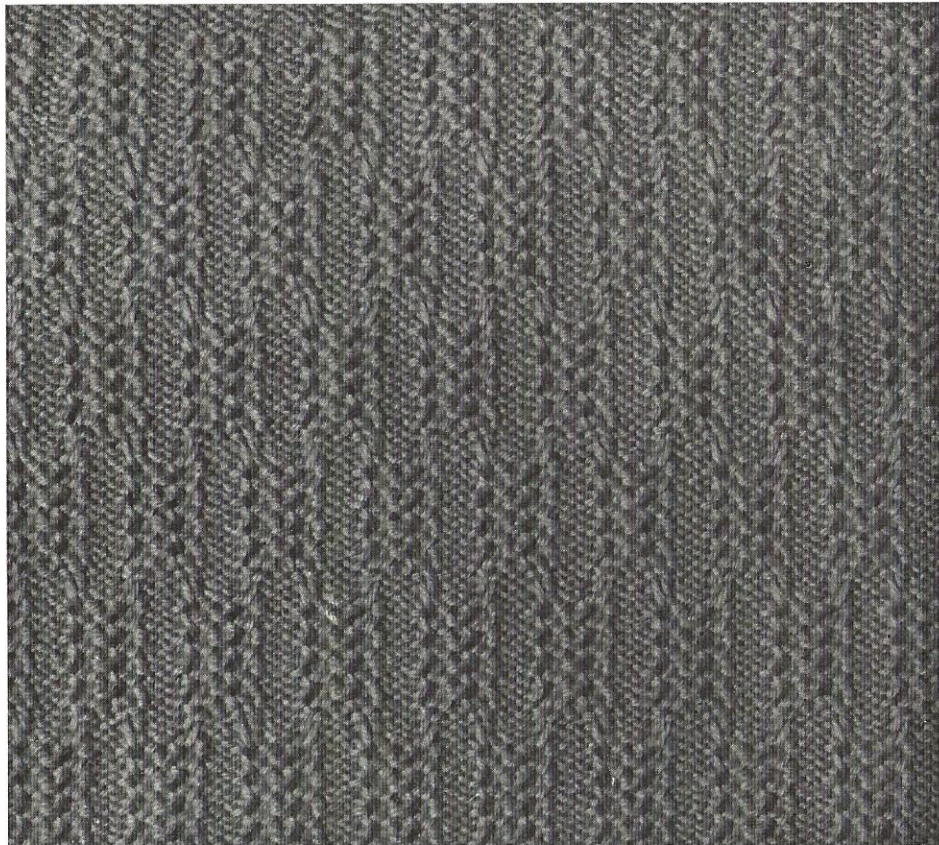

		0												RP		PR						
		12	11	10	9	8	7	6	5	4	3	2	1				0					
D ^B														1		R		0			R	2
														"			P	"			"	1
D ^B														"		R		"			"	2
														"		"		"		P		1
D ^B														"		"		"			R	2
														"			P	"			"	1
D ^B														"		R		"			"	2
														"		"		"		P		1
D ^B														"		"		"			R	2
														"			P	"			"	1
D ^B														"		R		"			R	2
														"			P	"			"	1
D ^B														"		R		"			"	2
														"		"		"		P		1

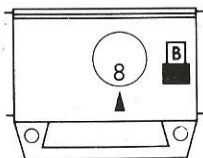

0														R P				P R			
12	11	10	9	8	7	6	5	4	3	2	1										
D	B	■	■	■	■	■	■	■	■	■	■	1			P	II		P	1		
D	B	■	■	■	■	■	■	■	■	■	■	"		"	"		"	"			
D	B	■	■	■	■	■	■	■	■	■	■	"		"	"		"	"			
D	B	■	■	■	■	■	■	■	■	■	■	"		"	"		"	"			
D	B	■	■	■	■	■	■	■	■	■	■	"		"	"		"	"			
D	B	■	■	■	■	■	■	■	■	■	■	"		"	"		"	"			
D	B	■	■	■	■	■	■	■	■	■	■	"		"	"		"	"			
D	B	■	■	■	■	■	■	■	■	■	■	"		"	"		"	"			
D	B	■	■	■	■	■	■	■	■	■	■	"		"	"		"	"			
D	B	■	■	■	■	■	■	■	■	■	■	"		"	"		"	"			
D	B	■	■	■	■	■	■	■	■	■	■	"		"	"		"	"			



HOW TO KNIT WITH MANY COLOURS.

You already know that your KNITTER has ONLY ONE Yarn Brake. This means you can only knit ONE Colour at a time from the Yarn Brake.

If you want to make very wide stripes, then it is quite quick to remove Colour 1 from the Feeder and the Yarn Brake and thread up Colour 2 when it should be knitted. Remove Colour 2 from the Yarn Brake and the Feeder, thread up Colour 3 and knit it.

It is easy to remove the Colours from the Yarn Brake without breaking the thread.

But if you knit narrow stripes, then it is much more convenient to Hand Feed Colour 1, 2 and 3.

With Colour 1 make an open edge cast on over 40 needles and knit a few rows - finishing with the carriage at the RIGHT.

Remove Colour 1 from the Feeder and the Yarn Brake and let it hang down from the side of the knitting.

Move the carriage towards the knitting until the Yarn Feeder is about 1 inch away from the first needles in knitting position - then thread Colour 2 through the Feeder and fasten the end onto the RIGHT hand Table Clamp.

DO YOU REMEMBER HOW YOU KNITTED IN THE NYLON THREAD?



Well - Hand Feeding for many Colours is just the same. In this case your hand operates as a Yarn Brake. As the carriage is moved further towards the knitting, you should pull the yarn up slightly, so that there is no slack yarn below the carriage.

Colour 2 is threaded in - move the carriage further towards the knitting, pull the yarn up a little until the Carriage reaches the first needles in knitting position. As soon as the needles have made contact with the carriage - let the yarn slide through your fingers as the carriage needs it to make stitches.

Knit 1 row - and again when you start the next row, pull the yarn up until the carriage reaches the first needles, this way you will not have slack yarn between the knitting and the carriage and the yarn will not get caught around the brushes below the Sinker Plate.

For the next row, when you move the carriage towards the knitting, again pull the yarn up until the carriage reaches the first needles in knitting position, then let the yarn slide through your fingers as it is knitted.

Practice Hand Feeding until you feel confident. The first rows may not be so easy, but in a very short time you will find it much easier to Hand Feed than to change the Colours in the Yarn Brake and the Feeder.

Hand Feeding is fun - useful to know and worth while practising.

When you wish to knit with 2 or 3 Colours - or even more - place the balls in a box on the floor below the machine.

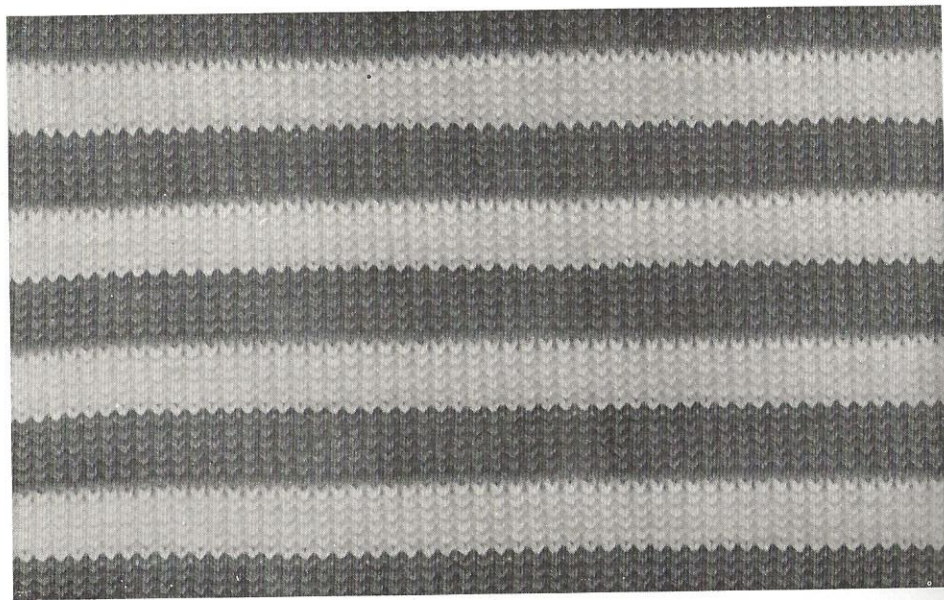

FAIR ISLE PATTERNS

This is a perfect chance to use your own ideas and talents with colours. Study this and the next pages - and soon you will enjoy the fun and excitement of Fair Isle knitting.

A very wide selection of Fair Isle patterns can be knitted with your machine - and here is a small collection of them. As soon as you know how to knit Fair Isle, you will be able to make your own ideas to suit your own personal taste.

The reading of the pattern diagram is the same as previously explained - with one single exception. You will find a number in column 4. This means TWO threads of yarn are knitted together in ONE row.

The first colour - (column 3) is knitted through the Yarn Feeder in the normal way, the second colour (column 4) is laid across the open needles in 'C' and 'D' position, by hand, before you knit each row.

When doing TUCK patterns - the needles are in 'B', 'C' and 'D' position.

But for Fair Isle patterns - the needles must be in 'C' and 'D' position ONLY.

You already know that you should knit a little pattern swatch before starting to knit the garment - this gives you the opportunity to try the pattern and feel confident when knitting the garment in it.

Fair Isle is knitted with several colours - but they should ALL be the SAME THICKNESS and the Tension Dial should be set 1 or 2 points looser when knitting Fair Isle patterns.

FAIR ISLE PATTERN 5007

Select the two different colours - both the same thickness yarn. Thread Colour 1 through the Yarn Brake and the Feeder and make an open edge cast on over 40 needles. Knit a few rows - finishing with the carriage at the RIGHT.

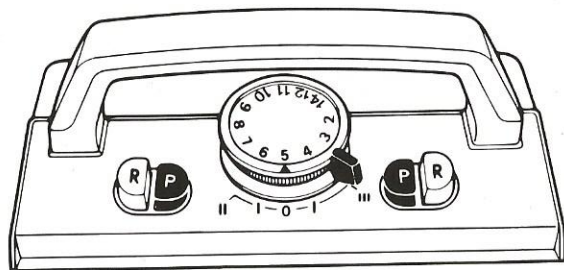

Push DOWN button P on the LEFT and RIGHT side of the carriage. Set the Cam Lever to III.

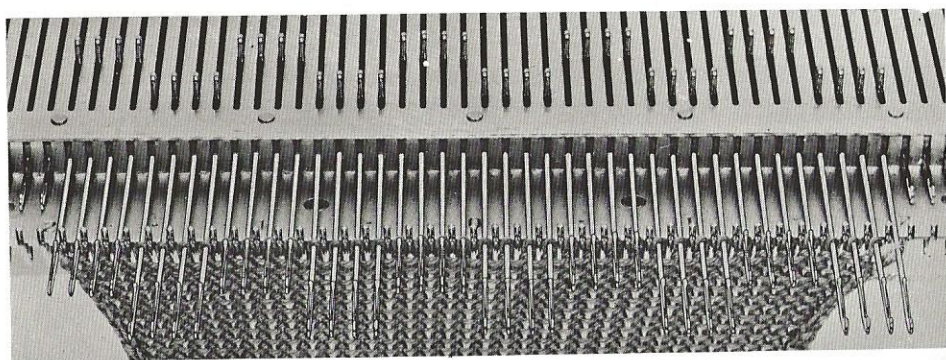

On the Selector set the Position Button to show C and the Number Dial to 8. Bring the FIRST 4 needles from the RIGHT from 'B' to 'D' position. Slide the Selector across the needles from RIGHT to LEFT. You have 4 needles in 'D' and 4 needles in 'C' position right across the knitting.



The latches of the needles in 'C' position are ALL open. Tie the end of Colour 2 onto the RIGHT hand Table Clamp and with your left hand lay the yarn across ALL needles towards the LEFT. Colour 2 lies on top of ALL needles in front of the Sinker Gate. Hold it down lightly at the LEFT and knit 1 row. As you knit, let the thread slide through your fingers as the carriage needs it to make the stitches.

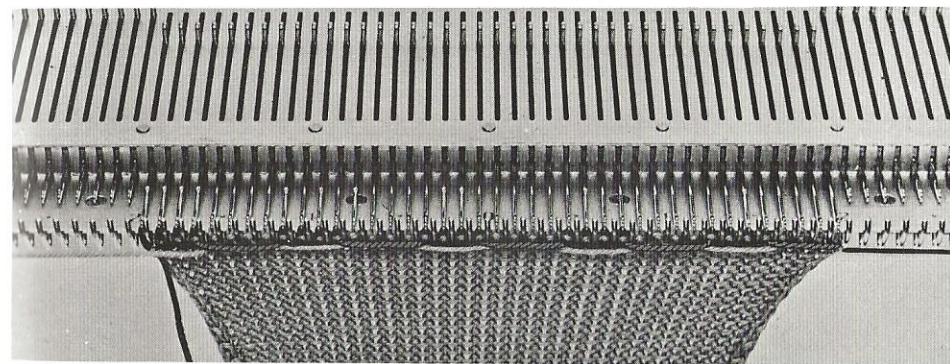

The carriage is at the LEFT and ALL needles have been knitted back to 'B' position. This means you will have to select your needles for the next row. 4 needles are knitted with Colour 1 and 4 needles are knitted with Colour 2.

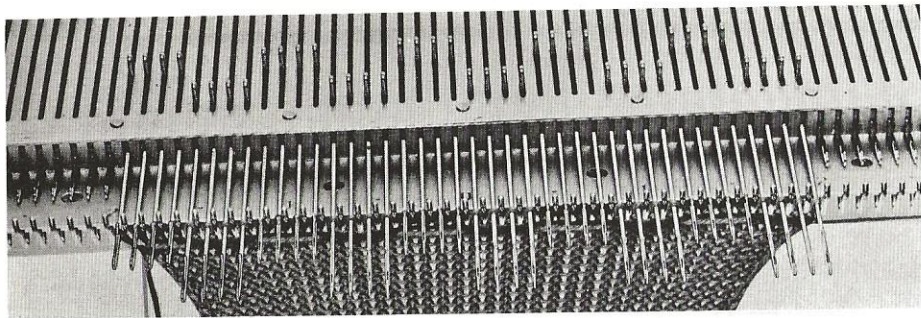

Again bring the first 4 needles from the RIGHT from 'B' to 'D' position. Slide the Selector across the needles from RIGHT to LEFT. You will knit the next row from LEFT to RIGHT so you must lay Colour 2 across the needles from LEFT to RIGHT. You always lay Colour 2 across the needles in the direction that you will knit the next row.

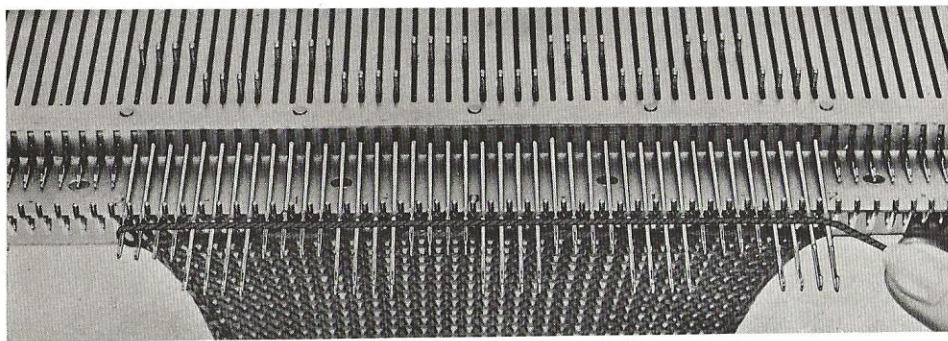

Hold Colour 2 lightly down at the RIGHT and let it slide through your fingers while you move the carriage across the knitting towards the RIGHT. Continue knitting a few more inches until you feel confident knitting two threads of yarn at a time.

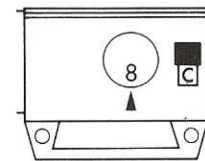

5007

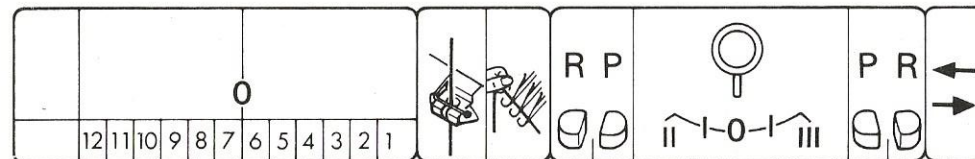

D	C	■ ■ ■ ■ ■ ■ ■ ■ ■ ■ ■ ■										1	2		P		III	P		1
D	C	■ ■ ■ ■ ■ ■ ■ ■ ■ ■ ■ ■										"	"		"		"	"		"
D	C	■ ■ ■ ■ ■ ■ ■ ■ ■ ■ ■ ■										"	"		"		"	"		"
D	C	■ ■ ■ ■ ■ ■ ■ ■ ■ ■ ■ ■										"	"		"		"	"		"



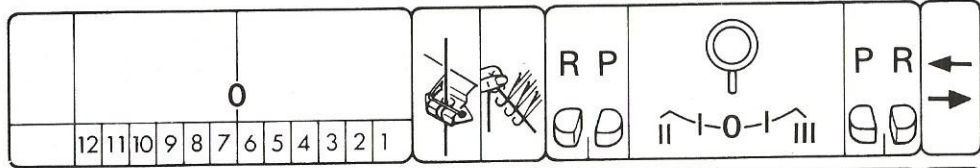
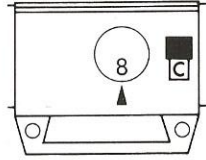

B		1		P	0	P	2
D ^C		"	2	"	III	"	1
D ^C		"	"	"	"	"	"
D ^C		"	"	"	"	"	"
D ^C		"	"	"	"	"	"
D ^C		"	"	"	"	"	"
D ^C		"	"	"	"	"	"

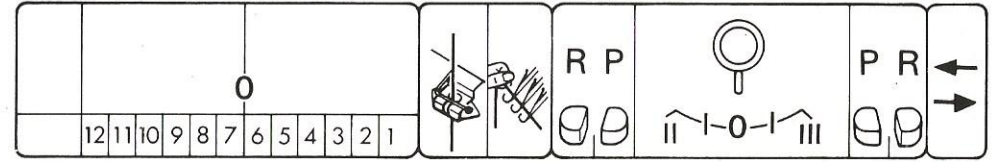
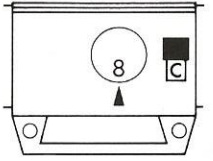
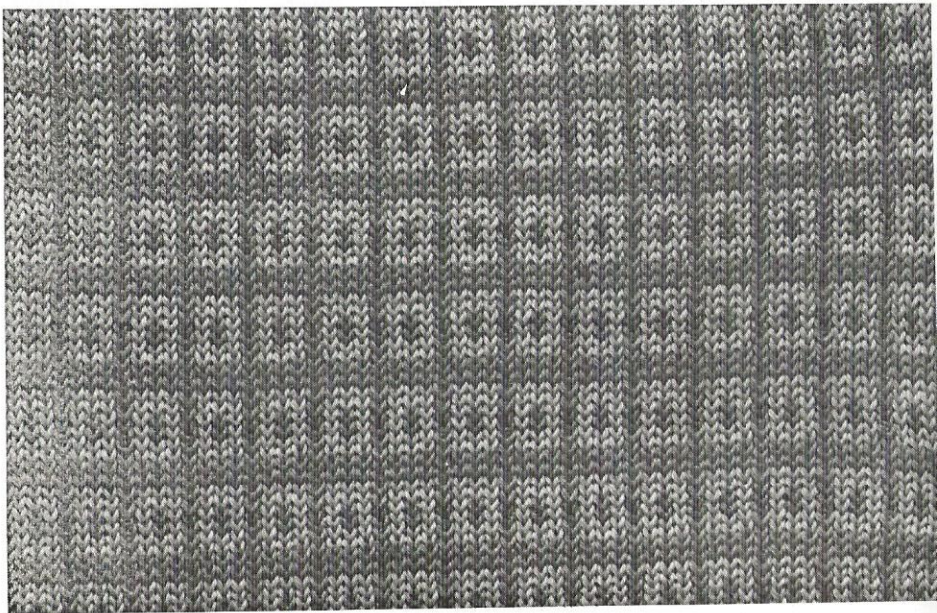

D ^C		1	2	P	III	P	1
D ^C		"	"	"	"	"	"
D ^C		"	"	"	"	"	"
D ^C		"	"	"	"	"	"
D ^C		"	"	"	"	"	"
D ^C		"	"	"	"	"	"
D ^C		"	"	"	"	"	"
D ^C		"	"	"	"	"	"

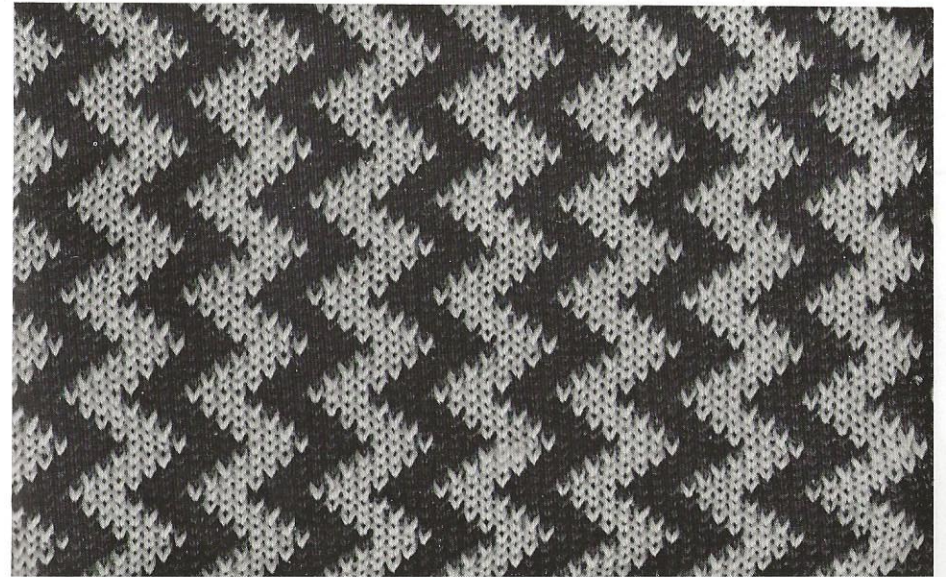

5004

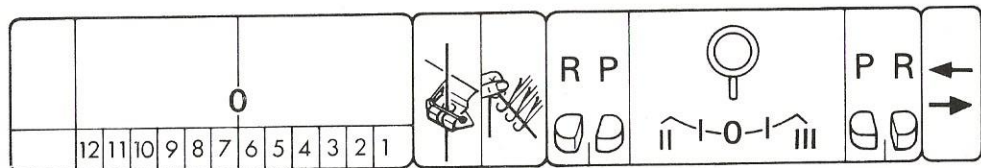
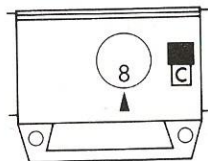

B	■ ■ ■ ■ ■ ■ ■ ■ ■ ■ ■ ■ ■ ■ ■ ■ ■ ■	1		P	0	P	2
D	■ ■ ■ ■ ■ ■ ■ ■ ■ ■ ■ ■ ■ ■ ■ ■ ■ ■	"	2	"	III	"	1
D	■ ■ ■ ■ ■ ■ ■ ■ ■ ■ ■ ■ ■ ■ ■ ■ ■ ■	"	"	"	"	"	"
B	■ ■ ■ ■ ■ ■ ■ ■ ■ ■ ■ ■ ■ ■ ■ ■ ■ ■	"		"	0	"	2
D	■ ■ ■ ■ ■ ■ ■ ■ ■ ■ ■ ■ ■ ■ ■ ■ ■ ■	"	2	"	III	"	1
D	■ ■ ■ ■ ■ ■ ■ ■ ■ ■ ■ ■ ■ ■ ■ ■ ■ ■	"	"	"	"	"	"

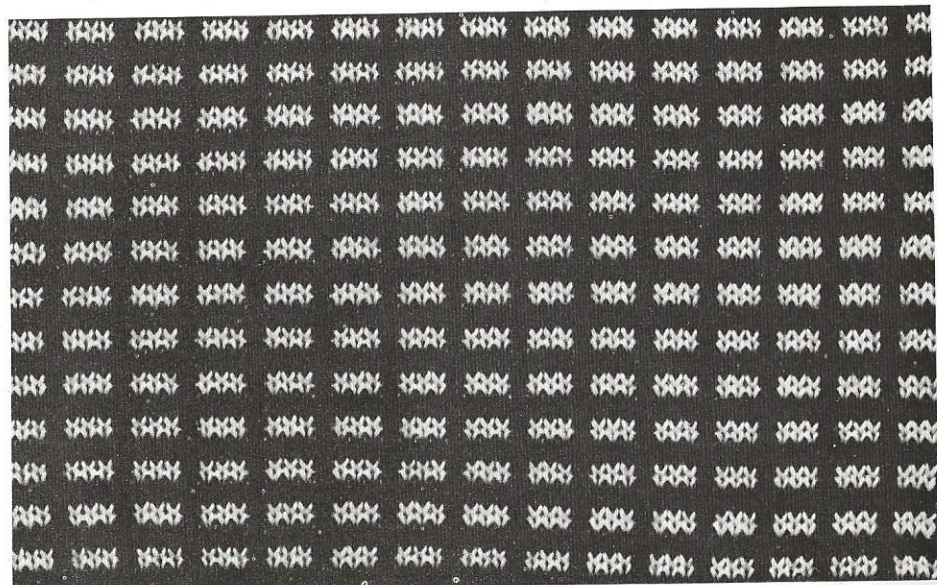

76

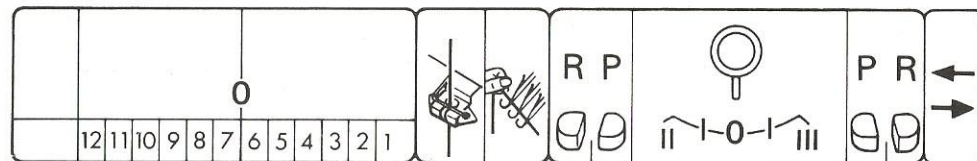
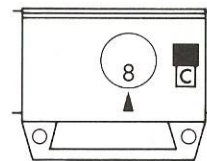

D	C	■ ■ ■ ■ ■ ■ ■ ■ ■ ■ ■ ■ ■ ■ ■ ■ ■ ■	1	2	P	III	P	1
D	C	■ ■ ■ ■ ■ ■ ■ ■ ■ ■ ■ ■ ■ ■ ■ ■ ■ ■	"	"	"	"	"	"
D	C	■ ■ ■ ■ ■ ■ ■ ■ ■ ■ ■ ■ ■ ■ ■ ■ ■ ■	"	"	"	"	"	"
D	C	■ ■ ■ ■ ■ ■ ■ ■ ■ ■ ■ ■ ■ ■ ■ ■ ■ ■	"	"	"	"	"	"
D	C	■ ■ ■ ■ ■ ■ ■ ■ ■ ■ ■ ■ ■ ■ ■ ■ ■ ■	"	"	"	"	"	"
D	C	■ ■ ■ ■ ■ ■ ■ ■ ■ ■ ■ ■ ■ ■ ■ ■ ■ ■	"	"	"	"	"	"
D	C	■ ■ ■ ■ ■ ■ ■ ■ ■ ■ ■ ■ ■ ■ ■ ■ ■ ■	"	"	"	"	"	"
D	C	■ ■ ■ ■ ■ ■ ■ ■ ■ ■ ■ ■ ■ ■ ■ ■ ■ ■	"	"	"	"	"	"
D	C	■ ■ ■ ■ ■ ■ ■ ■ ■ ■ ■ ■ ■ ■ ■ ■ ■ ■	"	"	"	"	"	"
D	C	■ ■ ■ ■ ■ ■ ■ ■ ■ ■ ■ ■ ■ ■ ■ ■ ■ ■	"	"	"	"	"	"
D	C	■ ■ ■ ■ ■ ■ ■ ■ ■ ■ ■ ■ ■ ■ ■ ■ ■ ■	"	"	"	"	"	"
D	C	■ ■ ■ ■ ■ ■ ■ ■ ■ ■ ■ ■ ■ ■ ■ ■ ■ ■	"	"	"	"	"	"
D	C	■ ■ ■ ■ ■ ■ ■ ■ ■ ■ ■ ■ ■ ■ ■ ■ ■ ■	"	"	"	"	"	"



315

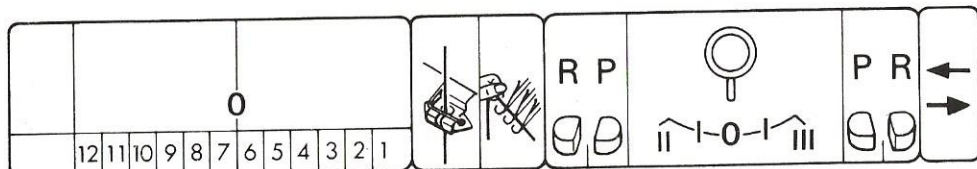
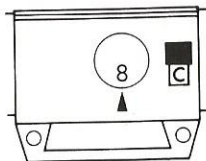

B	■ ■ ■ ■ ■ ■ ■ ■ ■ ■ ■ ■	1		P	0	P	2
D C	■ ■ ■ ■ ■ ■ ■ ■ ■ ■ ■ ■	"	2	"	III	"	1
D C	■ ■ ■ ■ ■ ■ ■ ■ ■ ■ ■ ■	"	"	"	"	"	"
D C	■ ■ ■ ■ ■ ■ ■ ■ ■ ■ ■ ■	"	"	"	"	"	"
D C	■ ■ ■ ■ ■ ■ ■ ■ ■ ■ ■ ■	"	"	"	"	"	"
D C	■ ■ ■ ■ ■ ■ ■ ■ ■ ■ ■ ■	"	"	"	"	"	"
B	■ ■ ■ ■ ■ ■ ■ ■ ■ ■ ■ ■	"		"	0	"	2
D C	■ ■ ■ ■ ■ ■ ■ ■ ■ ■ ■ ■	"	2	"	III	"	1
D C	■ ■ ■ ■ ■ ■ ■ ■ ■ ■ ■ ■	"	"	"	"	"	"
D C	■ ■ ■ ■ ■ ■ ■ ■ ■ ■ ■ ■	"	"	"	"	"	"
D C	■ ■ ■ ■ ■ ■ ■ ■ ■ ■ ■ ■	"	"	"	"	"	"
D C	■ ■ ■ ■ ■ ■ ■ ■ ■ ■ ■ ■	"	"	"	"	"	"

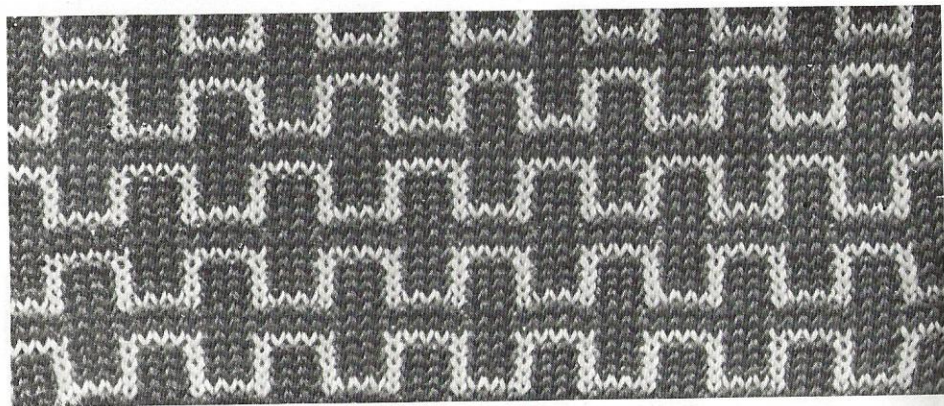

5003

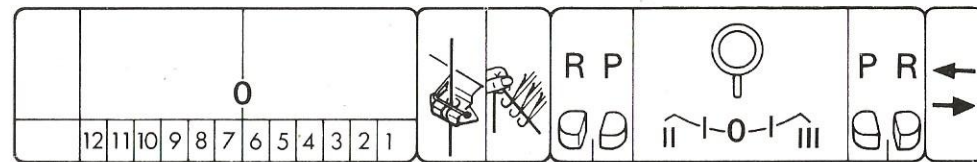
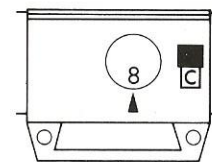

D C	■ ■ ■ ■ ■ ■ ■ ■ ■ ■ ■ ■	1	2	P		III	P	1
D C	■ ■ ■ ■ ■ ■ ■ ■ ■ ■ ■ ■	"	"	"	"	"	"	"
D C	■ ■ ■ ■ ■ ■ ■ ■ ■ ■ ■ ■	"	"	"	"	"	"	"
D C	■ ■ ■ ■ ■ ■ ■ ■ ■ ■ ■ ■	"	"	"	"	"	"	"

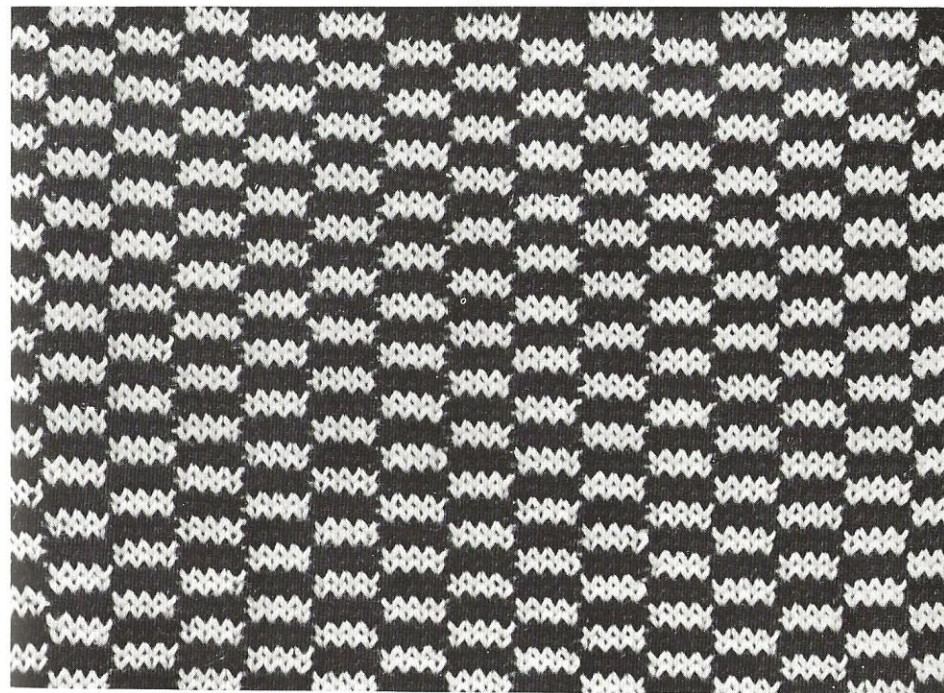

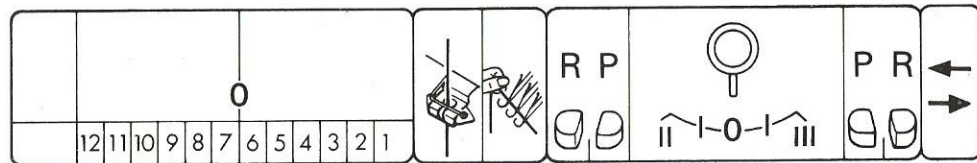
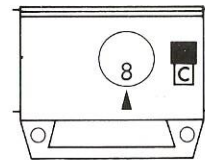
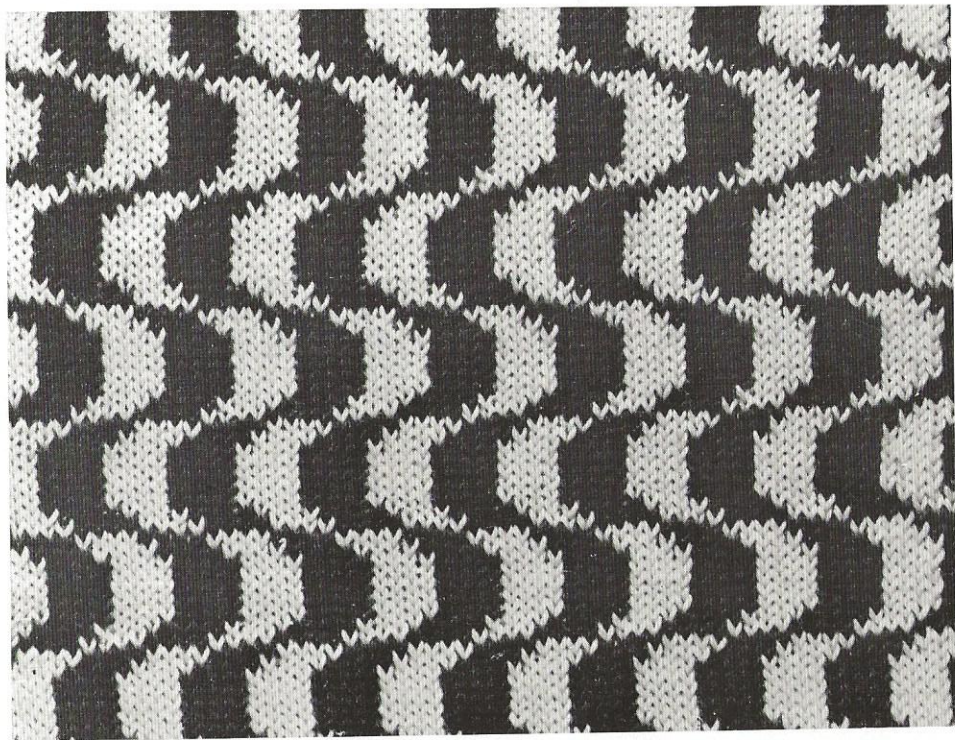

D C		1	2	P	III	P	1
D C		"	"	"	"	"	"
D C		"	"	"	"	"	"
D C		"	"	"	"	"	"
D C		"	"	"	"	"	"
D C		"	"	"	"	"	"
D C		"	"	"	"	"	"
D C		"	"	"	"	"	"
D C		"	"	"	"	"	"
D C		"	"	"	"	"	"
D C		"	"	"	"	"	"
D C		"	"	"	"	"	"
D C		"	"	"	"	"	"
D C		"	"	"	"	"	"
D C		"	"	"	"	"	"
D C		"	"	"	"	"	"

5002

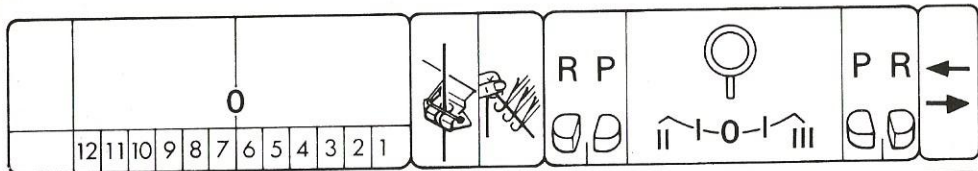
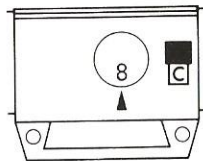

D C		1	2	P		III	P		1
D C		"	"	"		"	"		"
D C		"	"	"		"	"		"
D C		"	"	"		"	"		"

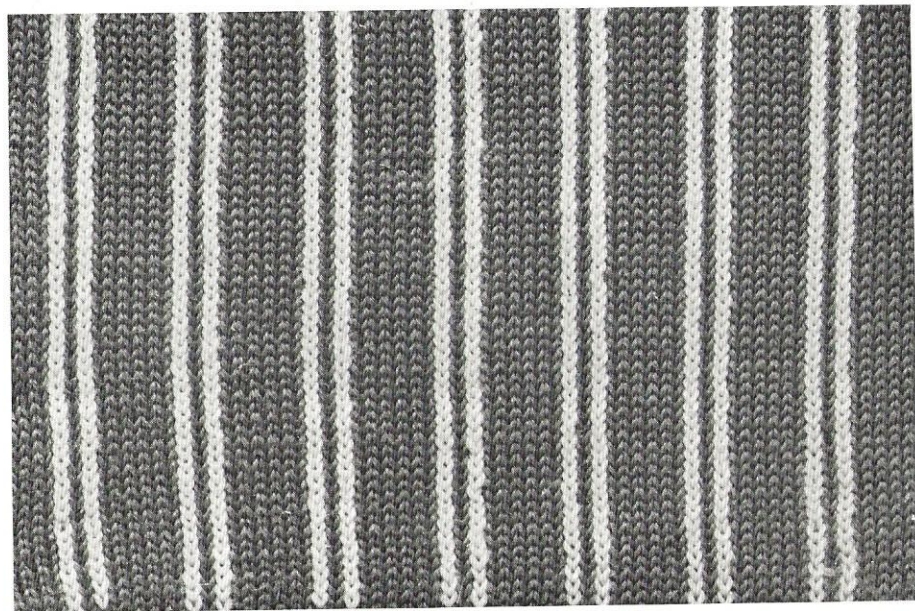

321

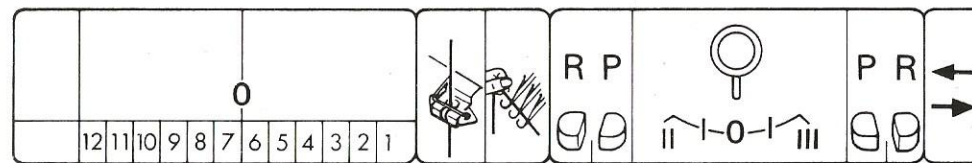
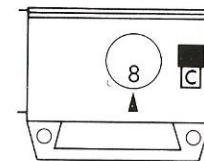

D C		1	2	P		III	P		1
D C		"	"	"		"	"		"
D C		"	"	"		"	"		"
D C		"	"	"		"	"		"
D C		"	"	"		"	"		"
D C		"	"	"		"	"		"
D C		"	"	"		"	"		"
D C		"	"	"		"	"		"

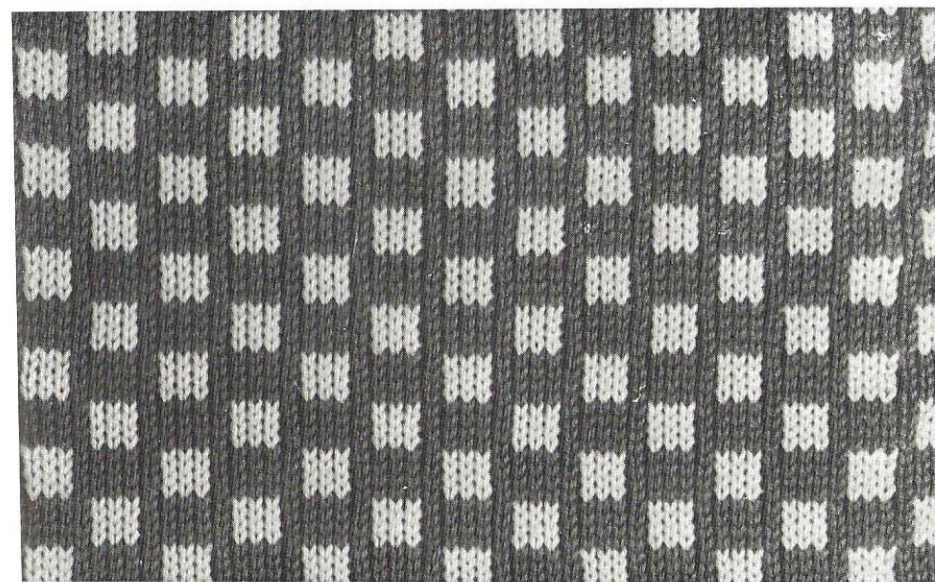

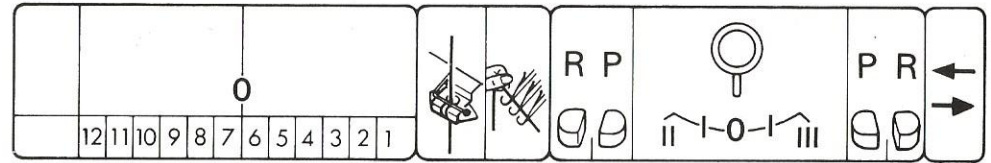
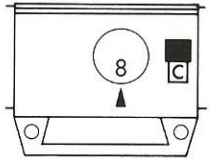
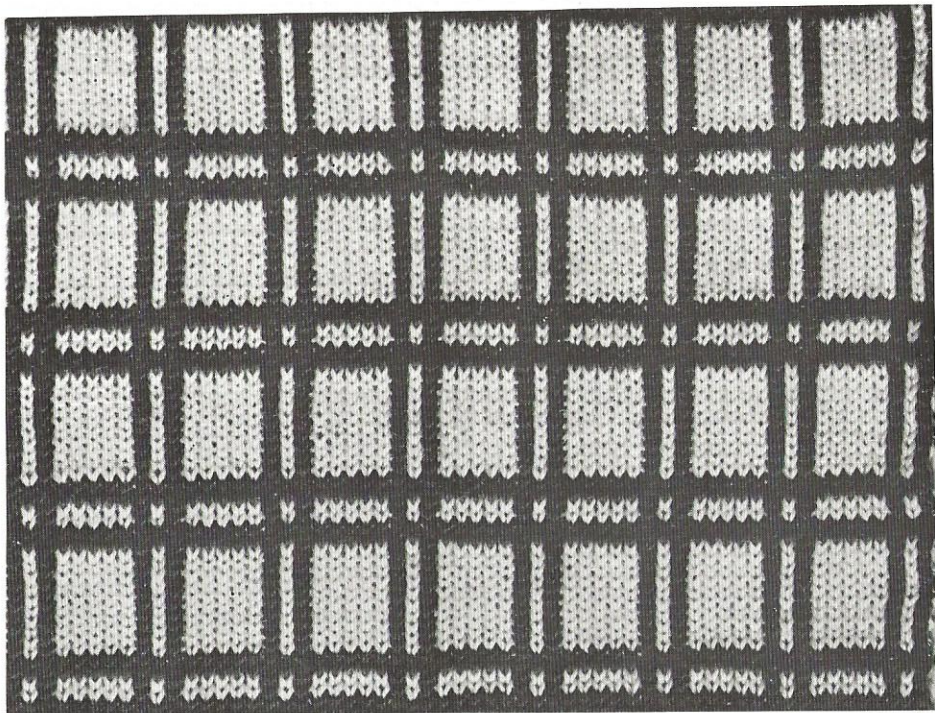

B	■ ■ ■ ■ ■ ■ ■ ■ ■ ■ ■ ■ ■ ■ ■ ■	1		P	0	P	2
D C	■ ■ ■ ■ ■ ■ ■ ■ ■ ■ ■ ■ ■ ■ ■ ■	"	2	"	III	"	1
D C	■ ■ ■ ■ ■ ■ ■ ■ ■ ■ ■ ■ ■ ■ ■ ■	"	"	"	"	"	"
B	■ ■ ■ ■ ■ ■ ■ ■ ■ ■ ■ ■ ■ ■ ■ ■	"		"	0	"	2
D C	■ ■ ■ ■ ■ ■ ■ ■ ■ ■ ■ ■ ■ ■ ■ ■	"	2	"	"	"	1
D C	■ ■ ■ ■ ■ ■ ■ ■ ■ ■ ■ ■ ■ ■ ■ ■	"	"	"	"	"	"
D C	■ ■ ■ ■ ■ ■ ■ ■ ■ ■ ■ ■ ■ ■ ■ ■	"	"	"	"	"	"
D C	■ ■ ■ ■ ■ ■ ■ ■ ■ ■ ■ ■ ■ ■ ■ ■	"	"	"	"	"	"
D C	■ ■ ■ ■ ■ ■ ■ ■ ■ ■ ■ ■ ■ ■ ■ ■	"	"	"	"	"	"
D C	■ ■ ■ ■ ■ ■ ■ ■ ■ ■ ■ ■ ■ ■ ■ ■	"	"	"	"	"	"
D C	■ ■ ■ ■ ■ ■ ■ ■ ■ ■ ■ ■ ■ ■ ■ ■	"	"	"	"	"	"
D C	■ ■ ■ ■ ■ ■ ■ ■ ■ ■ ■ ■ ■ ■ ■ ■	"	"	"	"	"	"
D C	■ ■ ■ ■ ■ ■ ■ ■ ■ ■ ■ ■ ■ ■ ■ ■	"	"	"	"	"	"
D C	■ ■ ■ ■ ■ ■ ■ ■ ■ ■ ■ ■ ■ ■ ■ ■	"	"	"	"	"	"



5008

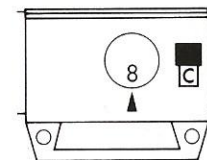

		0												R P				P R				
		12	11	10	9	8	7	6	5	4	3	2	1									
D	C	■	■	■	■	■	■	■	■	■	■	■	■	1	2			P		III	P	1
D	C	■	■	■	■	■	■	■	■	■	■	■	■	"	"			"		"	"	"
D	C	■	■	■	■	■	■	■	■	■	■	■	■	"	"			"		"	"	"
D	C	■	■	■	■	■	■	■	■	■	■	■	■	"	"			"		"	"	"
D	C	■	■	■	■	■	■	■	■	■	■	■	■	"	"			"		"	"	"
D	C	■	■	■	■	■	■	■	■	■	■	■	■	"	"			"		"	"	"
D	C	■	■	■	■	■	■	■	■	■	■	■	■	"	"			"		"	"	"
D	C	■	■	■	■	■	■	■	■	■	■	■	■	"	"			"		"	"	"
D	C	■	■	■	■	■	■	■	■	■	■	■	■	"	"			"		"	"	"
D	C	■	■	■	■	■	■	■	■	■	■	■	■	"	"			"		"	"	"
D	C	■	■	■	■	■	■	■	■	■	■	■	■	"	"			"		"	"	"
D	C	■	■	■	■	■	■	■	■	■	■	■	■	"	"			"		"	"	"
D	C	■	■	■	■	■	■	■	■	■	■	■	■	"	"			"		"	"	"
D	C	■	■	■	■	■	■	■	■	■	■	■	■	"	"			"		"	"	"
D	C	■	■	■	■	■	■	■	■	■	■	■	■	"	"			"		"	"	"
D	C	■	■	■	■	■	■	■	■	■	■	■	■	"	"			"		"	"	"
D	C	■	■	■	■	■	■	■	■	■	■	■	■	"	"			"		"	"	"

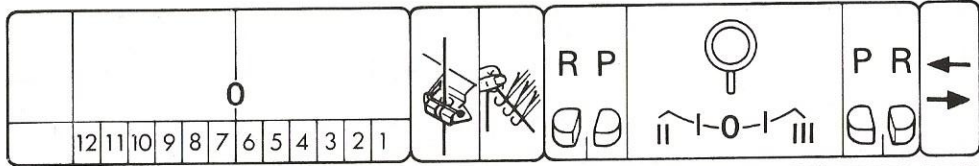
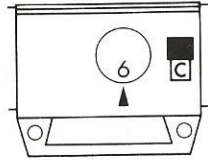

B	■ ■ ■ ■ ■ ■ ■ ■ ■ ■ ■ ■ ■ ■ ■ ■	1		P	0	P	2
D C	■ ■ ■ ■ ■ ■ ■ ■ ■ ■ ■ ■ ■ ■ ■ ■	"	2	"		III	"
D C	■ ■ ■ ■ ■ ■ ■ ■ ■ ■ ■ ■ ■ ■ ■ ■	"	"	"		"	"
D C	■ ■ ■ ■ ■ ■ ■ ■ ■ ■ ■ ■ ■ ■ ■ ■	"	"	"		"	"
D C	■ ■ ■ ■ ■ ■ ■ ■ ■ ■ ■ ■ ■ ■ ■ ■	"	"	"		"	"
D C	■ ■ ■ ■ ■ ■ ■ ■ ■ ■ ■ ■ ■ ■ ■ ■	"	"	"		"	"

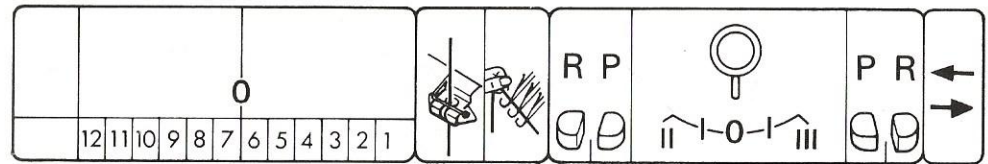
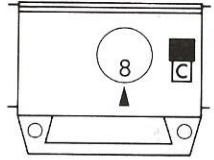
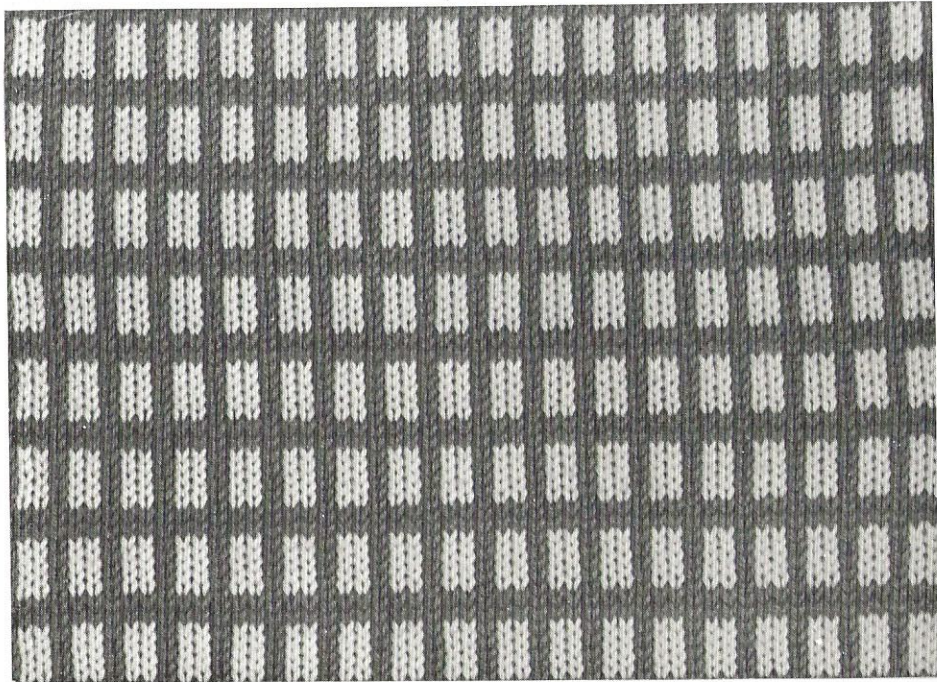

B	■ ■ ■ ■ ■ ■ ■ ■ ■ ■ ■ ■ ■ ■ ■ ■	1		P	II	0	P	2
D C	■ ■ ■ ■ ■ ■ ■ ■ ■ ■ ■ ■ ■ ■ ■ ■	"	2	"		III	"	1
D C	■ ■ ■ ■ ■ ■ ■ ■ ■ ■ ■ ■ ■ ■ ■ ■	"	"	"		"	"	"
D C	■ ■ ■ ■ ■ ■ ■ ■ ■ ■ ■ ■ ■ ■ ■ ■	"	"	"		"	"	"
D C	■ ■ ■ ■ ■ ■ ■ ■ ■ ■ ■ ■ ■ ■ ■ ■	"	"	"		"	"	"
D C	■ ■ ■ ■ ■ ■ ■ ■ ■ ■ ■ ■ ■ ■ ■ ■	"	"	"		"	"	"
D C	■ ■ ■ ■ ■ ■ ■ ■ ■ ■ ■ ■ ■ ■ ■ ■	"	"	"		"	"	"

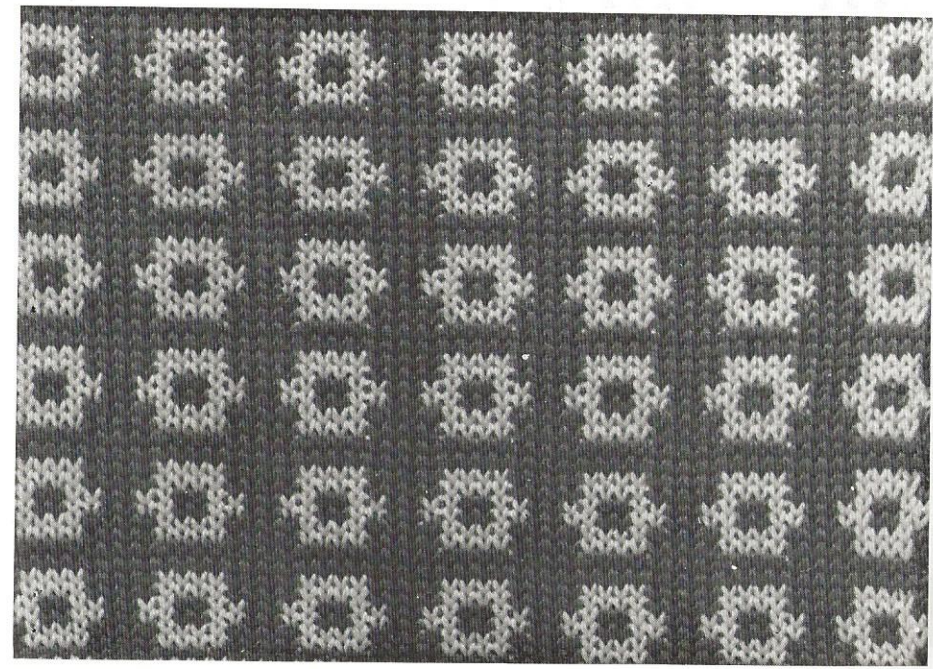

401

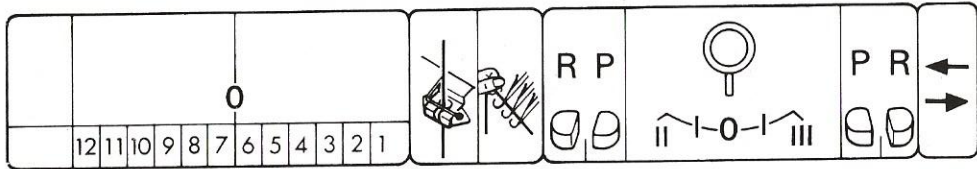
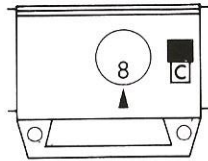

B		1		P	0	P	2
D C		"	2	"	III	"	1
D C		"	"	"	"	"	"
D C		"	"	"	"	"	"
D C		"	"	"	"	"	"
D C		"	"	"	"	"	"
D C		"	"	"	"	"	"
D C		"	"	"	"	"	"
D C		"	"	"	"	"	"



295

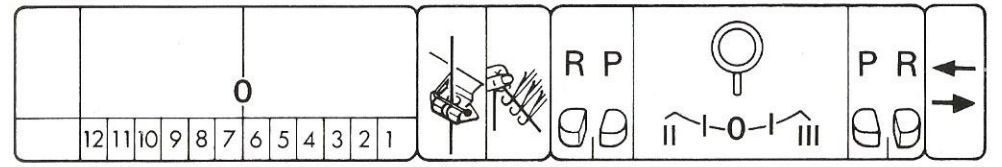
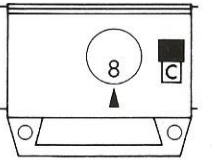

D C		1	2	P	III	P	1
D C		"	"	"	"	"	"
D C		"	"	"	"	"	"
D C		"	"	"	"	"	"
D C		"	"	"	"	"	"
D C		"	"	"	"	"	"
D C		"	"	"	"	"	"
D C		"	"	"	"	"	"
D C		"	"	"	"	"	"

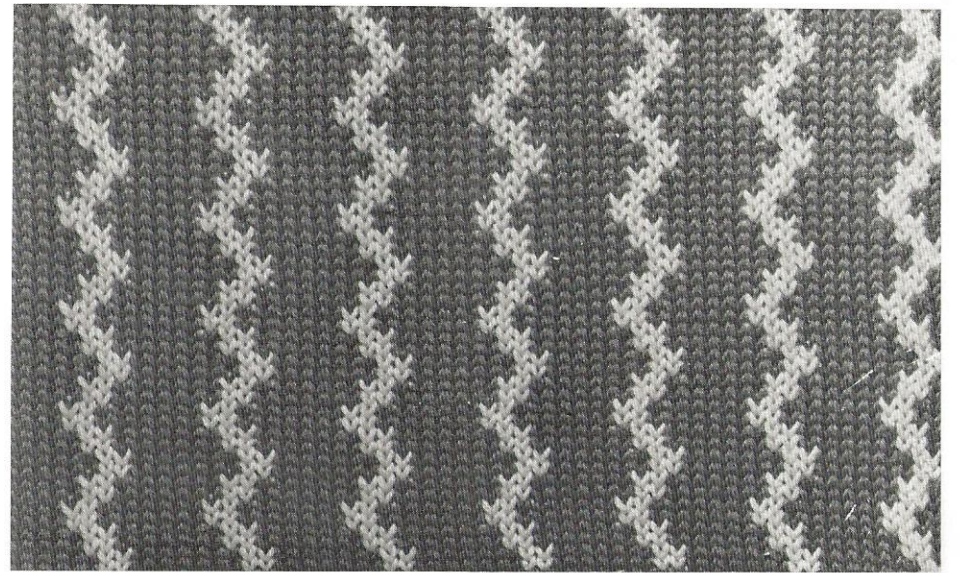

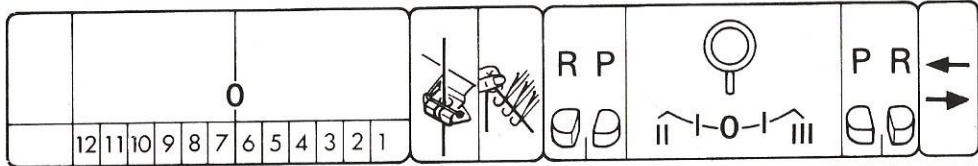
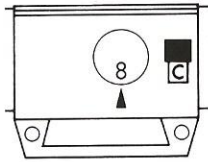

B	■ ■ ■ ■ ■ ■ ■ ■ ■ ■ ■ ■ ■ ■ ■ ■	1		P	0	P	2
D C	■ ■ ■ ■ ■ ■ ■ ■ ■ ■ ■ ■ ■ ■ ■ ■	"	2	"		III	"
D C	■ ■ ■ ■ ■ ■ ■ ■ ■ ■ ■ ■ ■ ■ ■ ■	"	"	"		"	"
D C	■ ■ ■ ■ ■ ■ ■ ■ ■ ■ ■ ■ ■ ■ ■ ■	"	"	"		"	"
D C	■ ■ ■ ■ ■ ■ ■ ■ ■ ■ ■ ■ ■ ■ ■ ■	"	"	"		"	"
D C	■ ■ ■ ■ ■ ■ ■ ■ ■ ■ ■ ■ ■ ■ ■ ■	"	"	"		"	"
D C	■ ■ ■ ■ ■ ■ ■ ■ ■ ■ ■ ■ ■ ■ ■ ■	"	"	"		"	"
D C	■ ■ ■ ■ ■ ■ ■ ■ ■ ■ ■ ■ ■ ■ ■ ■	"	"	"		"	"
D C	■ ■ ■ ■ ■ ■ ■ ■ ■ ■ ■ ■ ■ ■ ■ ■	"	"	"		"	"
D C	■ ■ ■ ■ ■ ■ ■ ■ ■ ■ ■ ■ ■ ■ ■ ■	"	"	"		"	"

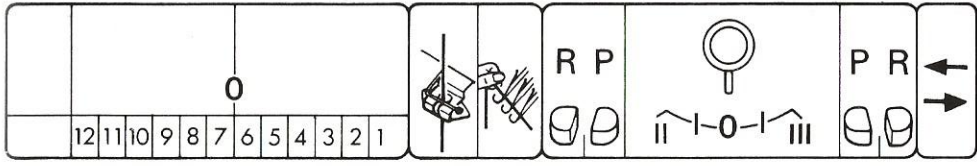
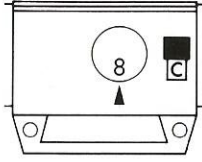
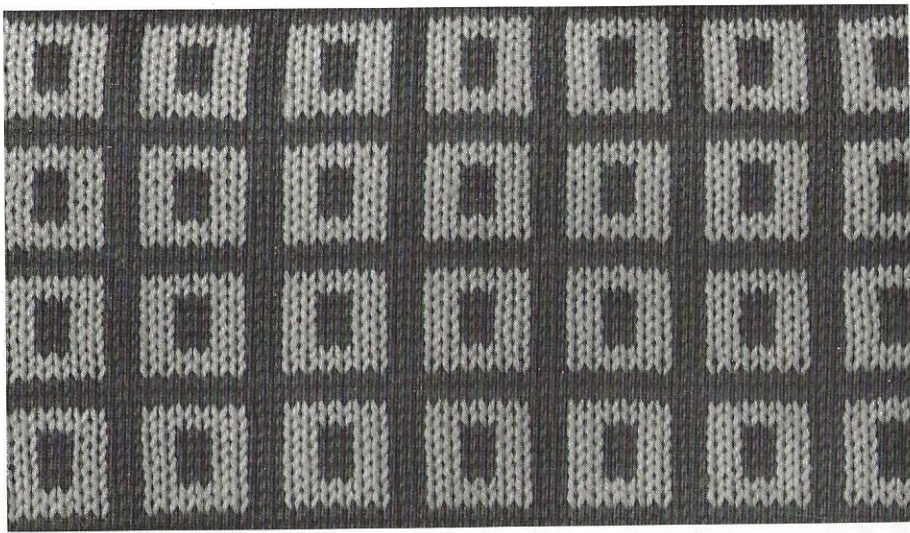

B	■ ■ ■ ■ ■ ■ ■ ■ ■ ■ ■ ■ ■ ■ ■ ■	1		P	0	P	2
D C	■ ■ ■ ■ ■ ■ ■ ■ ■ ■ ■ ■ ■ ■ ■ ■	"	2	"		III	"
D C	■ ■ ■ ■ ■ ■ ■ ■ ■ ■ ■ ■ ■ ■ ■ ■	"	"	"		"	"
D C	■ ■ ■ ■ ■ ■ ■ ■ ■ ■ ■ ■ ■ ■ ■ ■	"	"	"		"	"
D C	■ ■ ■ ■ ■ ■ ■ ■ ■ ■ ■ ■ ■ ■ ■ ■	"	"	"		"	"
D C	■ ■ ■ ■ ■ ■ ■ ■ ■ ■ ■ ■ ■ ■ ■ ■	"	"	"		"	"
D C	■ ■ ■ ■ ■ ■ ■ ■ ■ ■ ■ ■ ■ ■ ■ ■	"	"	"		"	"
D C	■ ■ ■ ■ ■ ■ ■ ■ ■ ■ ■ ■ ■ ■ ■ ■	"	"	"		"	"
D C	■ ■ ■ ■ ■ ■ ■ ■ ■ ■ ■ ■ ■ ■ ■ ■	"	"	"		"	"
D C	■ ■ ■ ■ ■ ■ ■ ■ ■ ■ ■ ■ ■ ■ ■ ■	"	"	"		"	"

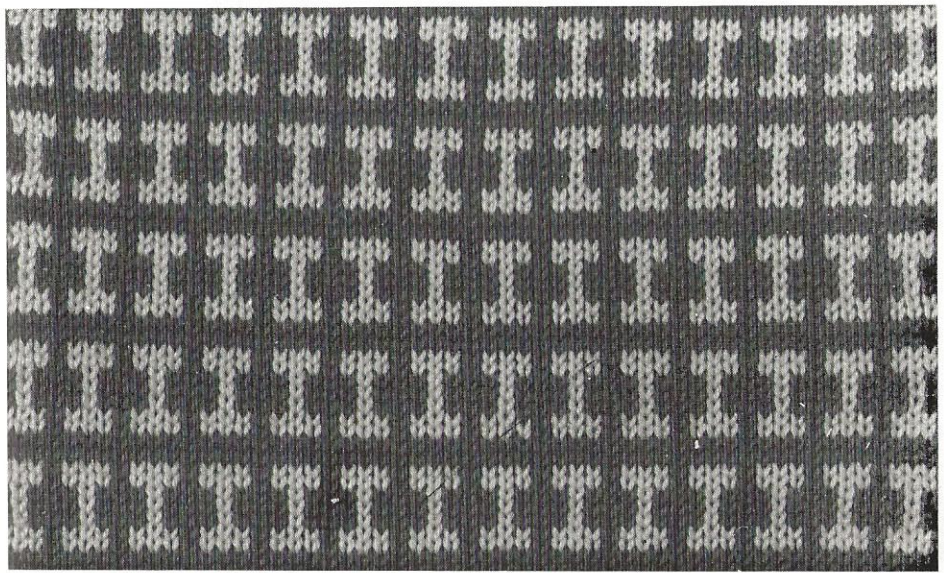

AUTOMATIC LACE PATTERN 540

This is a new and exciting way to knit Lace patterns WITHOUT transferring stitches.

This pattern can be knitted with thin to medium yarn - or even with crochet cotton.

The Lace is made by simple and easy needle settings. In the top of each column 2 you will find the needle setting.

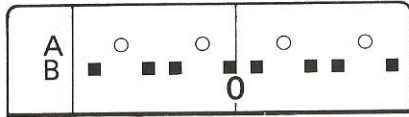

1. O is the centre of the needle bed - from here you make the needle setting to the RIGHT and the LEFT.

2. o are the needles which remain in 'A' position.
3. ■ are the needles which have to come to 'B' position.

Bring the 40 centre needles from 'A' to 'B' position.

1. Leave the FIRST needle RIGHT of centre in 'B' position.
2. Bring the next needle back to 'A' position.
3. Leave the next TWO needles in 'B' position.

Repeat 2 and 3 until all 20 needles RIGHT of centre are set.

1. Leave the FIRST needle LEFT of centre in 'B' position.
2. Bring the next needle back to 'A' position.
3. Leave the next TWO needles in 'B' position.

Repeat 2 and 3 until all 20 needles LEFT of centre are set.

Now bring the needles which are in 'B' position up to 'D' position. Starting with the FIRST needle from the LEFT in 'D' position, make a closed edge cast on, by hand, knit a few rows - finishing with the carriage at the RIGHT.

Now you can start knitting the pattern as shown in the diagram. If you wish to knit Lace patterns after the hem, transfer the stitches of the needles which must go back to 'A' position onto their adjacent needles, then bring the empty needles back to 'A' position.

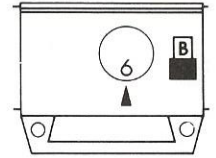

540

A B	○	○	○	○	O					R P	P R	←	→				
A B	○	○	○	○	○	○	○	○	○	○	○	○	○	○			
	12	11	10	9	8	7	6	5	4	3	2	1					
D B	■	■	■	■	■	■	■	■	■	■	■	■	1	R	0	R	3
													"	"	"	P	1
D B	■	■	■	■	■	■	■	■	■	■	■	■	"	"	"	P	1
													"	"	"	P	1
D B	■	■	■	■	■	■	■	■	■	■	■	■	"	"	"	P	1
													"	"	"	P	1

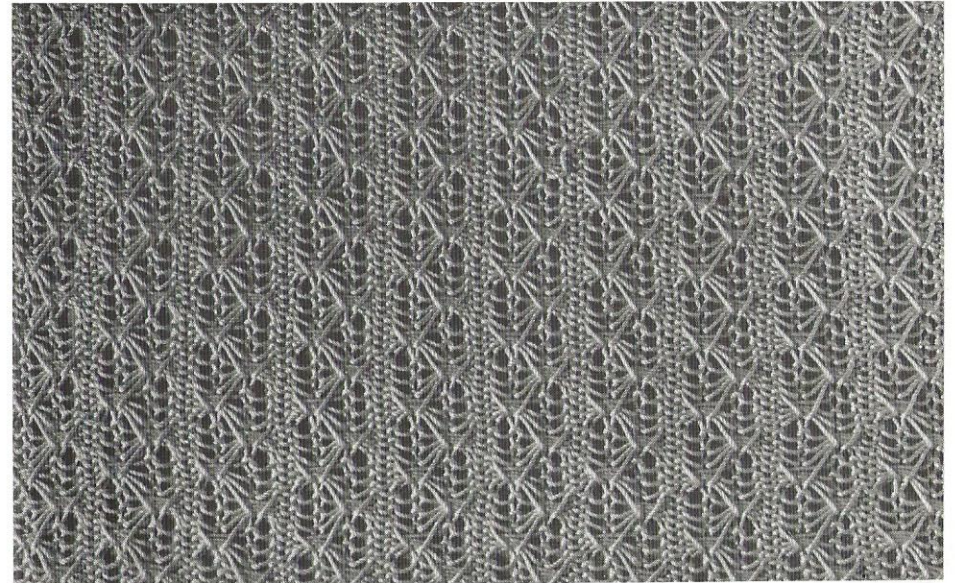

528

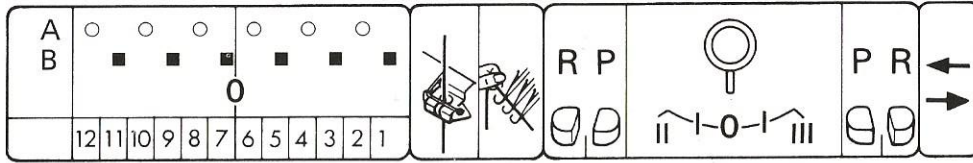
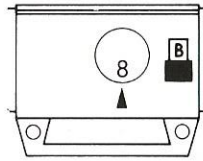

D	B	■	■	■	■	■	1	R	0	R	4
							"	"	"	P	2
D	B	■	■	■	■	■	"	"	"	R	4
							"	"	"	P	2
D	B	■	■	■	■	■	"	"	"	R	4
							"	"	"	P	2
D	B	■	■	■	■	■	"	"	"	R	4
							"	"	"	P	2

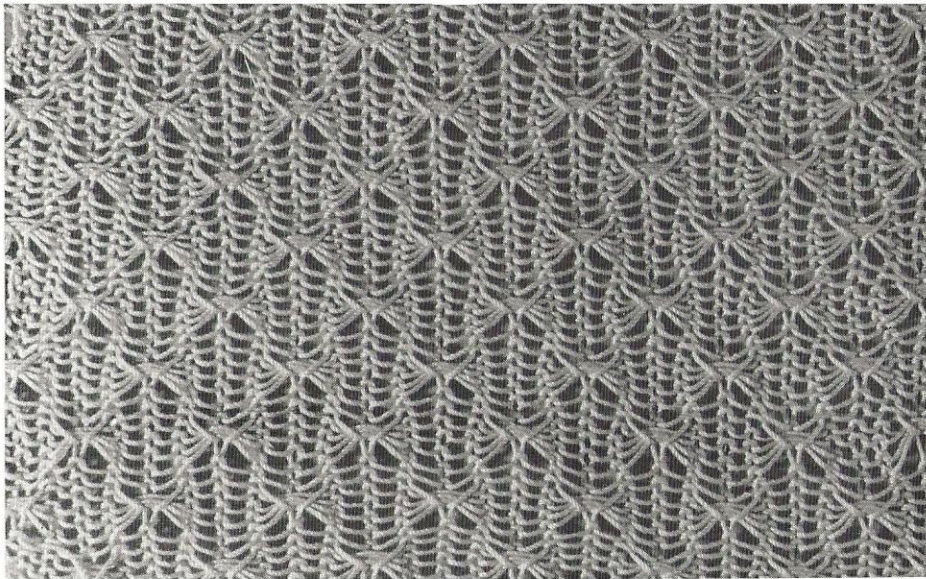

503

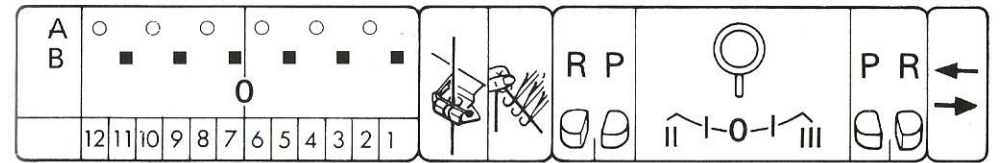
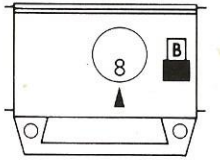



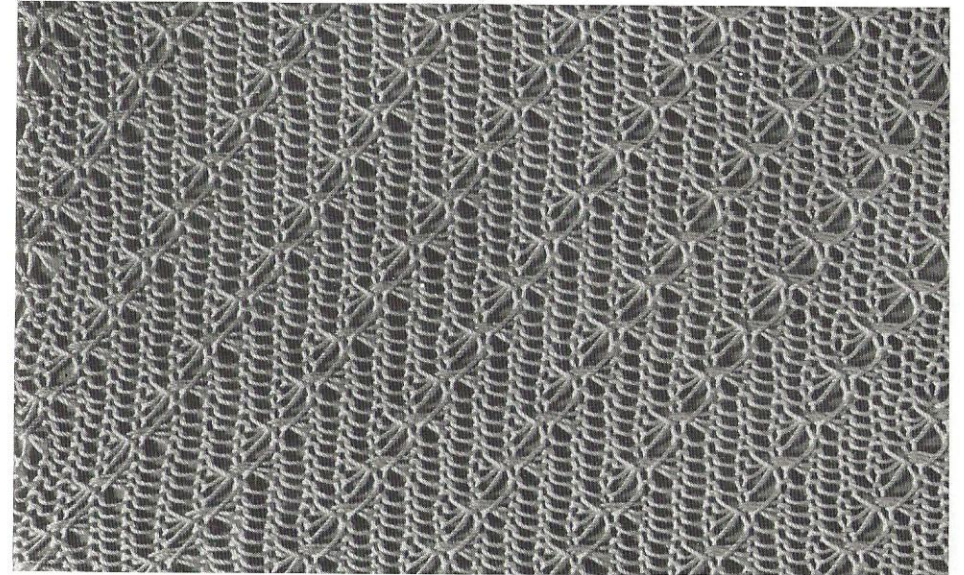

D	B	■	■	■	■	■	1	R	0	R	3
							"	"	"	P	1
D	B	■	■	■	■	■	"	"	"	R	3
							"	"	"	P	1
D	B	■	■	■	■	■	"	"	"	R	3
							"	"	"	P	1
D	B	■	■	■	■	■	"	"	"	R	3
							"	"	"	P	1

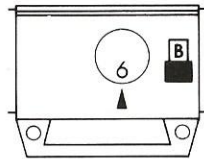

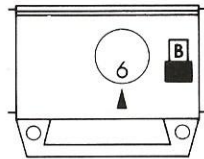
534

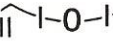



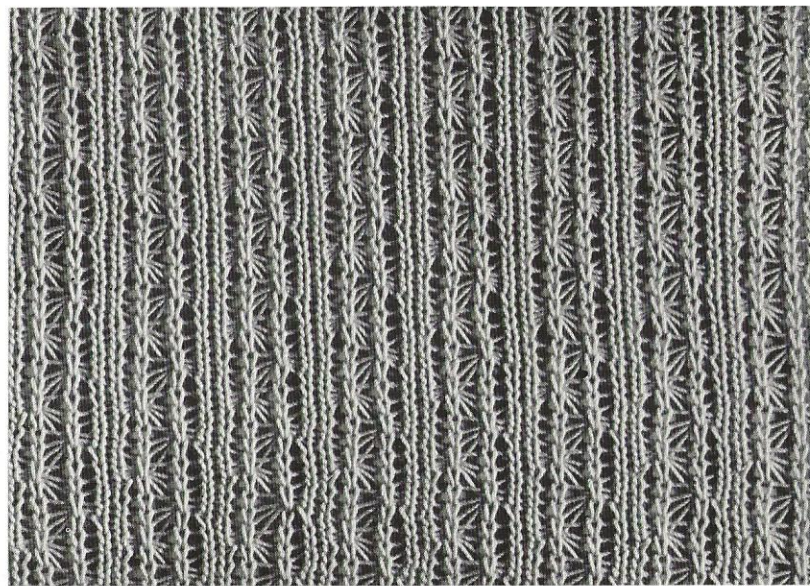

A B	○ ○	○ ○	○ ○	○ ○			R P		P R ←	→
	12 11 10 9 8 7 6 5 4 3 2 1	0								
D B	■ ■ ■ ■	■ ■ ■ ■	■ ■ ■ ■	■ ■ ■ ■	1	R	0		R	3
					"	"	"	P		1
D B	■ ■ ■ ■	■ ■ ■ ■	■ ■ ■ ■	■ ■ ■ ■	"	"	"		R	3
					"	"	"	P		1
D B	■ ■ ■ ■	■ ■ ■ ■	■ ■ ■ ■	■ ■ ■ ■	"	"	"		R	3
					"	"	"	P		1
D B	■ ■ ■ ■	■ ■ ■ ■	■ ■ ■ ■	■ ■ ■ ■	"	"	"		R	3
					"	"	"	P		1

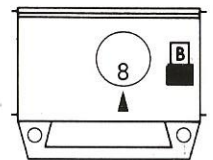

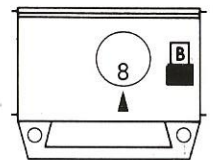
537

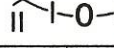

A B	○ ○	○ ○	○ ○	○ ○			R P		P R ←	→
	12 11 10 9 8 7 6 5 4 3 2 1	0								
D B	■ ■ ■ ■	■ ■ ■ ■	■ ■ ■ ■	■ ■ ■ ■	1	R	0		R	3
					"	"	"	P		1
D B	■ ■ ■ ■	■ ■ ■ ■	■ ■ ■ ■	■ ■ ■ ■	"	"	"		R	3
					"	"	"	P		1
D B	■ ■ ■ ■	■ ■ ■ ■	■ ■ ■ ■	■ ■ ■ ■	"	"	"		R	3
					"	"	"	P		1
D B	■ ■ ■ ■	■ ■ ■ ■	■ ■ ■ ■	■ ■ ■ ■	"	"	"		R	3
					"	"	"	P		1

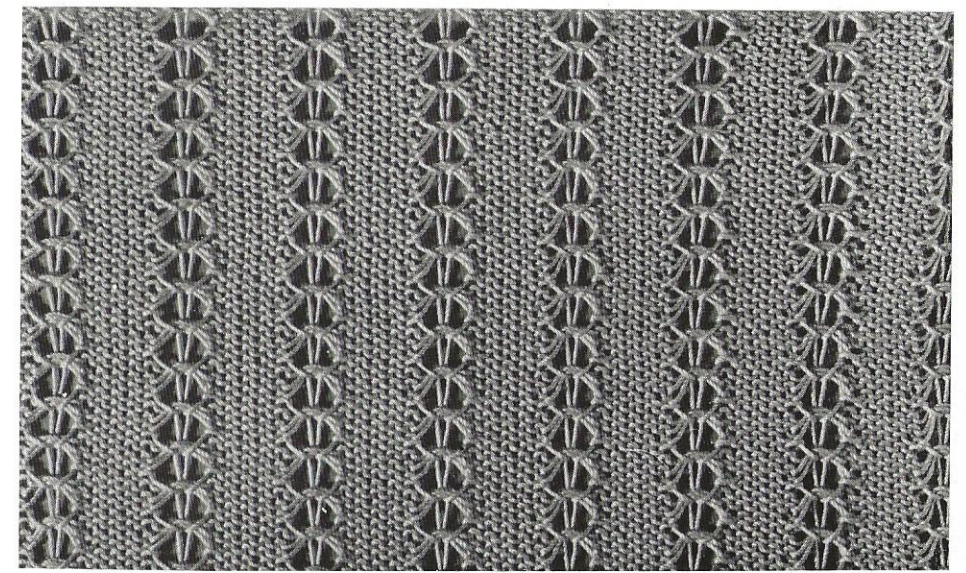

535

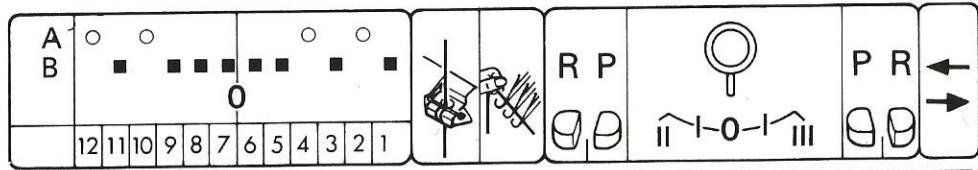
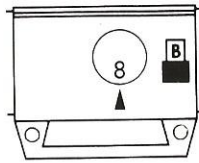

D B	■	■	■	■	■	■	■	■	■	■	■	■	■	■	1	R	0	R	4	
															"	"	"	P	2	
D B	■	■	■	■	■	■	■	■	■	■	■	■	■	■	"	"	"		R	4
															"	"	"	P	2	
D B	■	■	■	■	■	■	■	■	■	■	■	■	■	■	"	"	"		R	4
															"	"	"	P	2	
D B	■	■	■	■	■	■	■	■	■	■	■	■	■	■	"	"	"		R	4
															"	"	"	P	2	

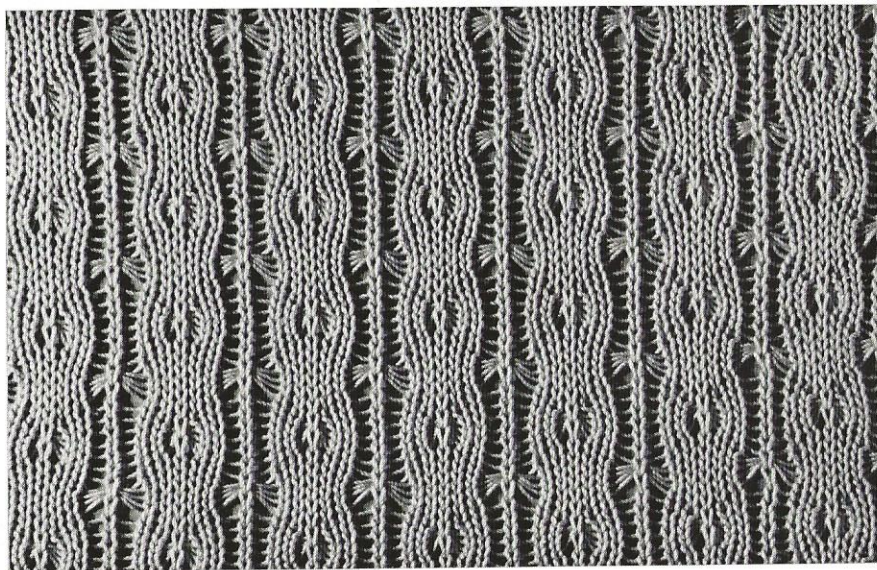

513

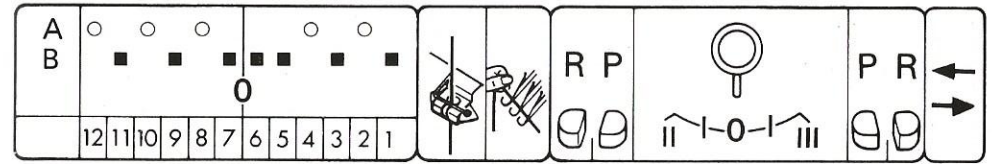
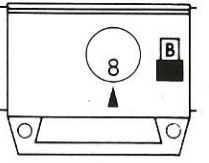

D B	■	■	■	■	■	■	■	■	■	■	■	■	■	■	1	R	0		R	3
															"	"	"	P	1	
D B	■	■	■	■	■	■	■	■	■	■	■	■	■	■	"	"	"		R	3
															"	"	"	P	1	
D B	■	■	■	■	■	■	■	■	■	■	■	■	■	■	"	"	"		R	3
															"	"	"	P	1	
D B	■	■	■	■	■	■	■	■	■	■	■	■	■	■	"	"	"		R	3
															"	"	"	P	1	

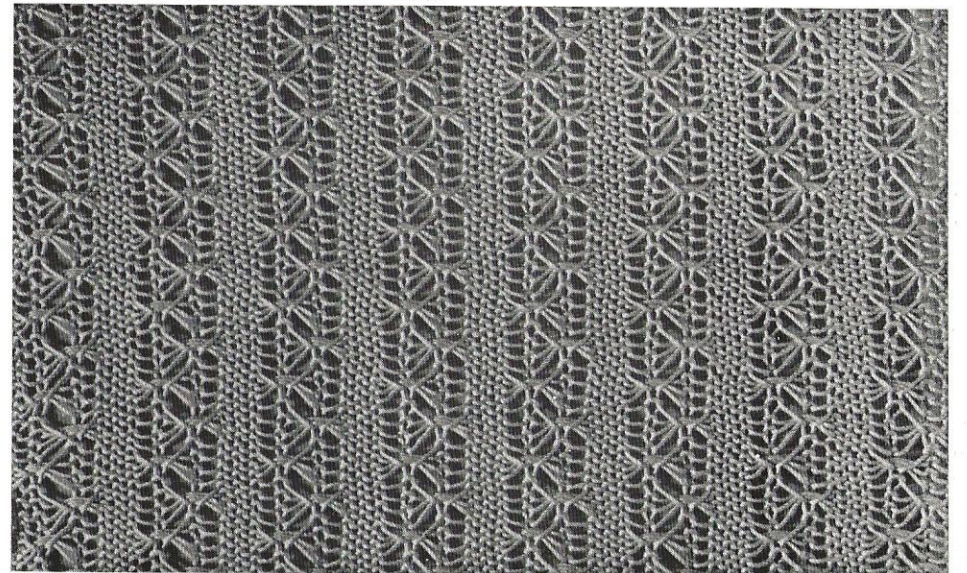

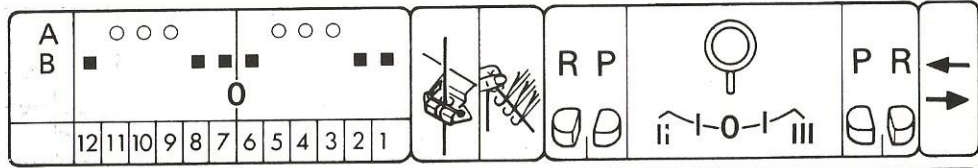
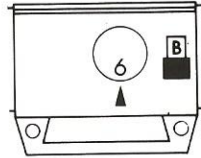

D	B	■ ■ ■ ■ ■	1	R	0	R	3
			"	"	"	P	1
D	B	■ ■ ■ ■ ■	"	"	"	R	3
			"	"	"	P	1
D	B	■ ■ ■ ■ ■	"	"	"	R	3
			"	"	"	P	1
D	B	■ ■ ■ ■ ■	"	"	"	R	3
			"	"	"	P	1

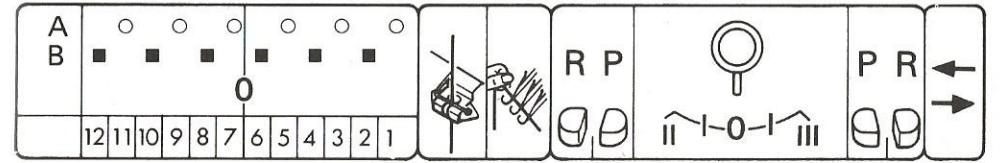
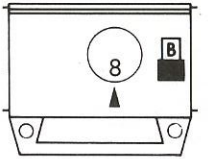
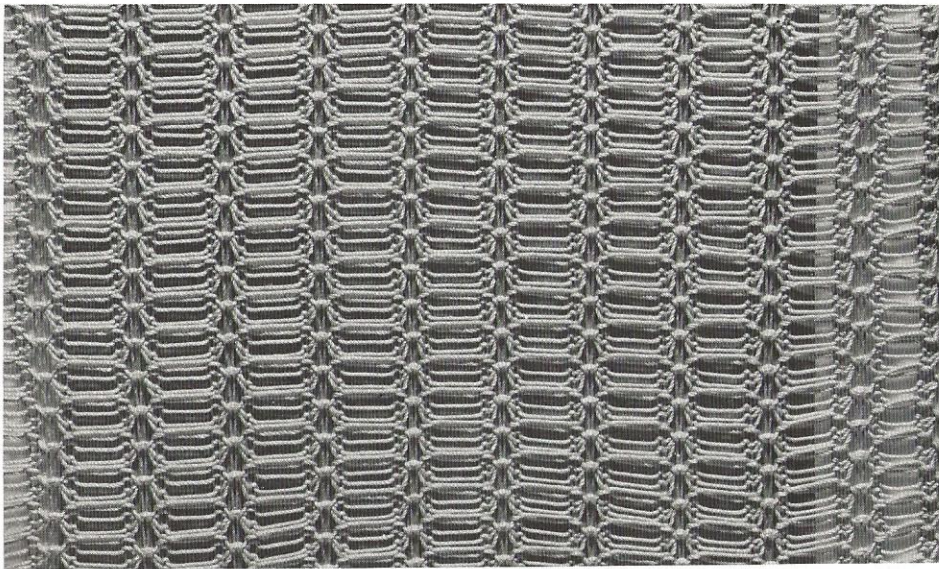

D	B	■ ■ ■ ■ ■	1	R	0	R	3
			"	"	"	P	1
D	B	■ ■ ■ ■ ■	"	"	"	R	3
			"	"	"	P	1
D	B	■ ■ ■ ■ ■	"	"	"	R	3
			"	"	"	P	1
D	B	■ ■ ■ ■ ■	"	"	"	R	3
			"	"	"	P	1
D	B	■ ■ ■ ■ ■	"	"	"	R	3
			"	"	"	P	1

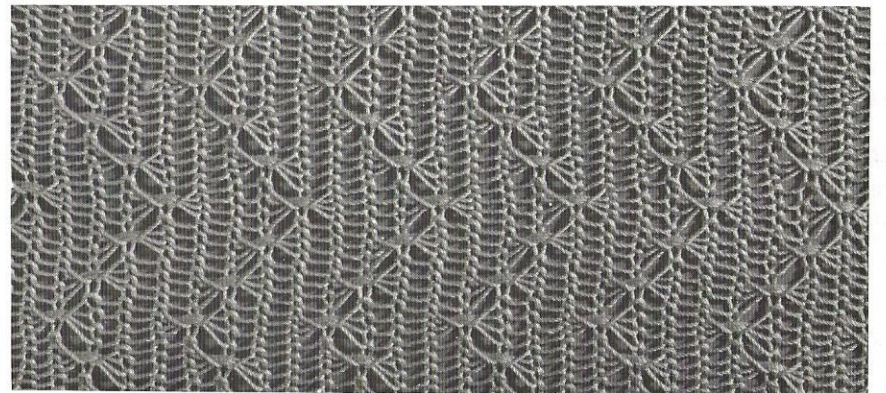

INCREASING AND DECREASING WHILE KNITTING PATTERNS.



The instructions in the Pattern Book tell you to ALWAYS start setting the first group of needles as shown in the pattern diagram, but this means ONLY when you knit straight, not when you need to shape the knitting.

Please try it. Make an open edge cast on over 40 needles and knit a few rows, finishing with the carriage at the RIGHT.

Push DOWN the button P on the RIGHT and leave the Cam Lever in the centre. On the LEFT button P is up.

1. Bring every 4th needle from the RIGHT up to 'D' position.
 2. Knit 2 rows.
- Repeat 1 and 2 four times. Now increase 1 stitch at the RIGHT.

If you now brought the 4th needle up to 'D' position, your pattern would be wrong as you have increased 1 extra needle at the RIGHT. This extra needle starts a new pattern group of needles towards the RIGHT.

This means you must bring up the 1st and then the 5th needle from the RIGHT to 'D' position.

Knit the new needle setting five times. Again increase 1 stitch at the RIGHT. Now you bring the SECOND and the 6th needle from the RIGHT up to 'D' position and then every following 4th needle.

Knit the new needle setting five times.
You do not need to worry about the needles at the LEFT - as you start selecting the needles towards the LEFT, the LEFT side edge is always correct.

When increasing while knitting Fair Isle patterns - bring the new increased needles to 'C' or 'D' position depending on which Colour they must be knitted with.

INCREASING AND DECREASING

WHILE KNITTING PATTERNS.

When you wish to decrease 1 stitch while knitting the same pattern as explained for the increasing, decrease 1 stitch and bring the 3rd needle up to 'D' position.

This means - while decreasing or binding off, you reduce the number of needles which you leave in 'B' position at the RIGHT side edge.

When knitting Fair Isle patterns - ALWAYS - decrease or bind off after the needles have been knitted back to 'B' position and BEFORE you make the next selection of needles.

Lined writing area consisting of 22 horizontal lines.

COPYRIGHT EMPISAL INTERNATIONAL

Printed in Japan