

**SERVICE MANUAL**  
**FOR**  
**MODEL-120 KNITTER**

Position of the main cams.....1

Adjustment of Arm.....2

Adjustment of Needle Bed.....4

Position of the main cams

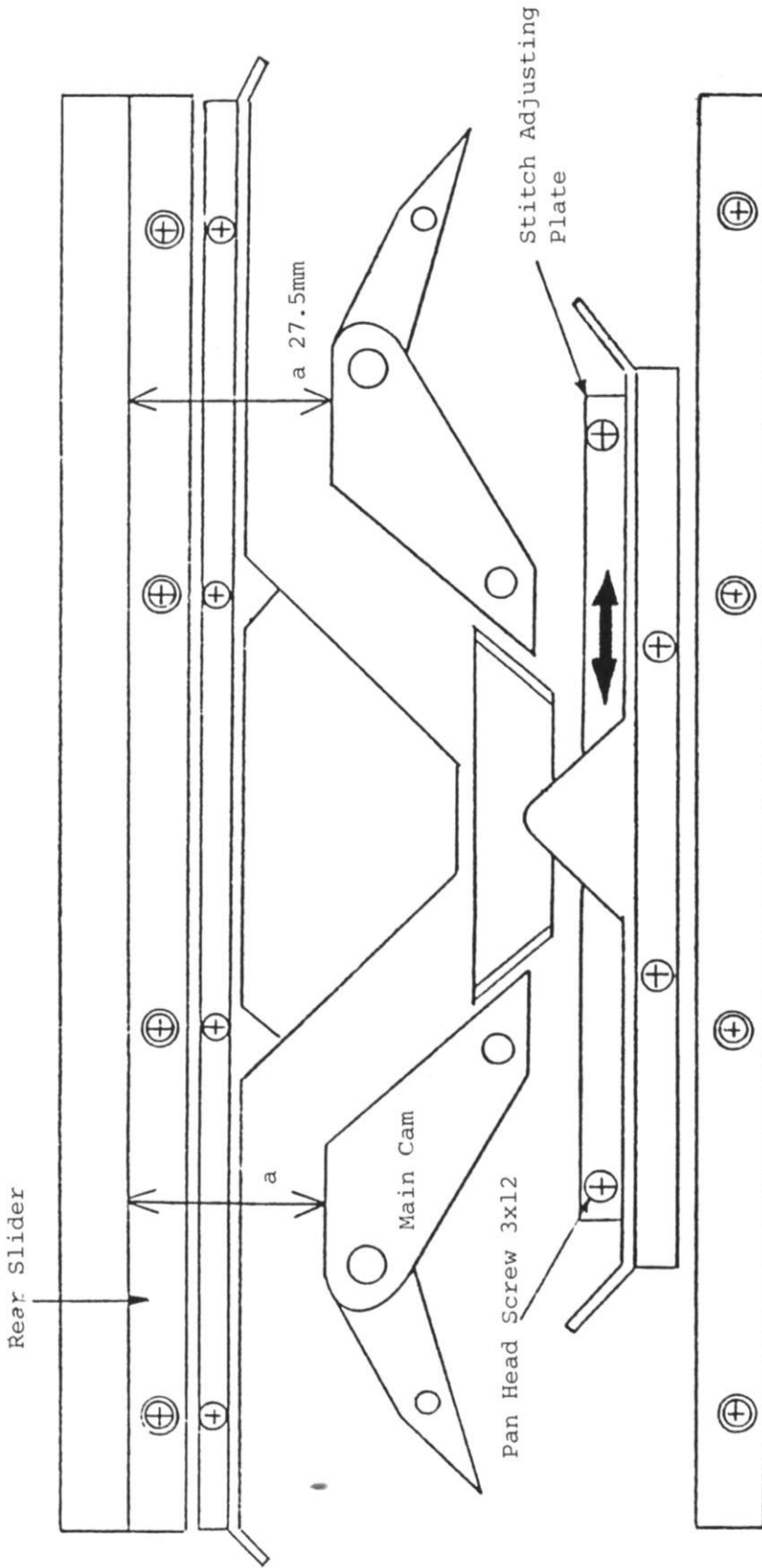

The position of the main cams is adjusted to 27.5mm from the rear slider when the Stitch Dial is set at 5. If the measurement for one main cam is different from that for the other main cam, loosen the pan head screw (3x12) securing the Stitch Adjusting Plate, and move it to right or left to have the main cams into correct position.

ADJUSTMENT OF ARM

Required measurements

- 1. P.N. Measurement (Adjusted clearance between the Fabric Presser and the Needle).....0 - 0.5mm

To check the measurement, push the needles into holding position, and measure the clearance between the bottom of the needle and the front edge of the needle bed.

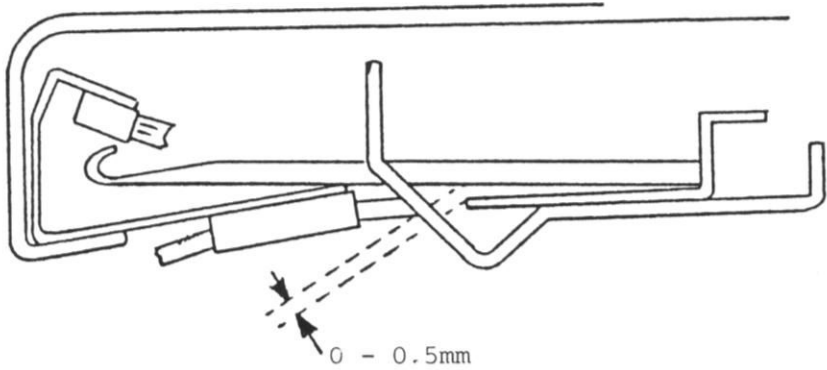

- 2. P.S. Measurement (Adjusted clearance between the slant face of the Sinker and the edge of the Fabric Pressers.)..... 1.3 - 1.8mm

Y.S. Measurement (Adjusted clearance between the Sinker and the end of the Yarn Feeder.)..... 1.8 - 2.2mm

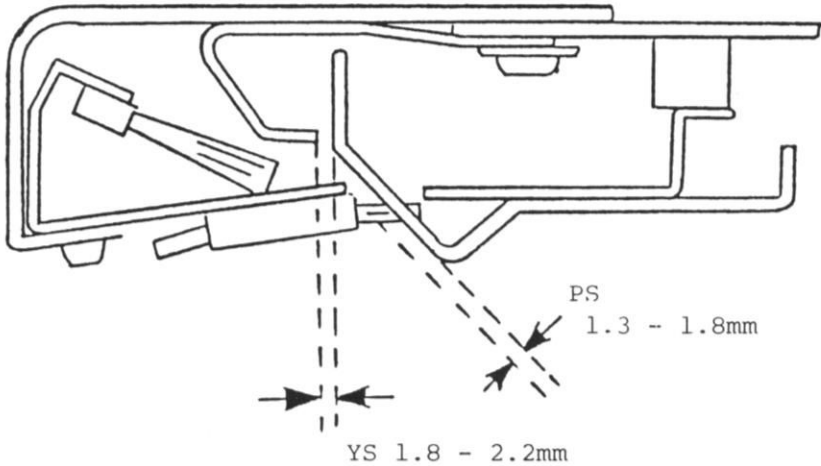

- 3. Y.N. Measurement (Adjusted clearance between the bottom face of the Yarn Feeder and the top of the needle hook.).....0.4 - 0.8mm

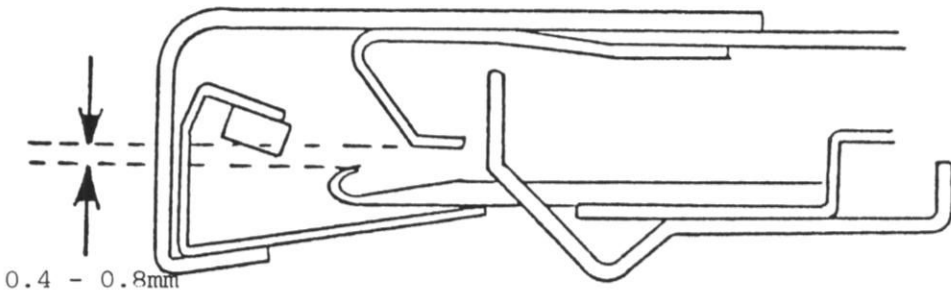

## How to adjust the measurements of the Arm

### 1. P.N. Measurement

Place the Arm on the plane surface with its bottom side up and press down the Fabric Pressers or bend wider the Arm by force as for the Arm of the punch card knitters.

### 2. Y.S. Measurement

Loosen two pan head screws 4x6 securing the Yarn Feeder, and move it forward or backward to bring it into the correct measurement.

Refer to the next page for adjusting the P.S. measurement.

### 3. Y.N. Measurement

If the Y.N. Measurement is more than the required one, place the washers between the Arm and the Yarn Feeder.

If the Y.N. Measurement is less than the required one, bend the Yarn Feeder.

### How to adjust the P.S. Measurement

Loosen the SW Pan Head Screws 3x6 securing the Arm Stoppers, and move them backward or forward to have the P.S. Measurement into the correct one.

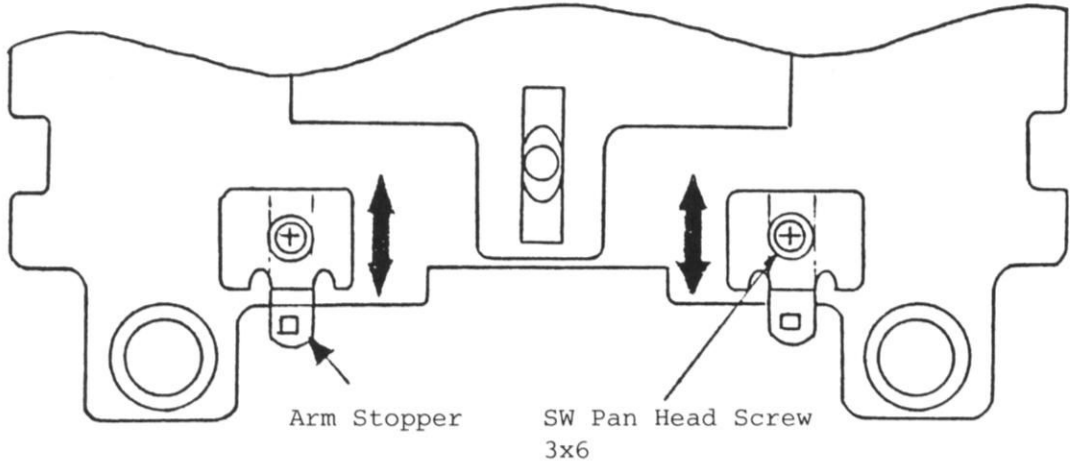

The needle bed has the following adjusted measurements.

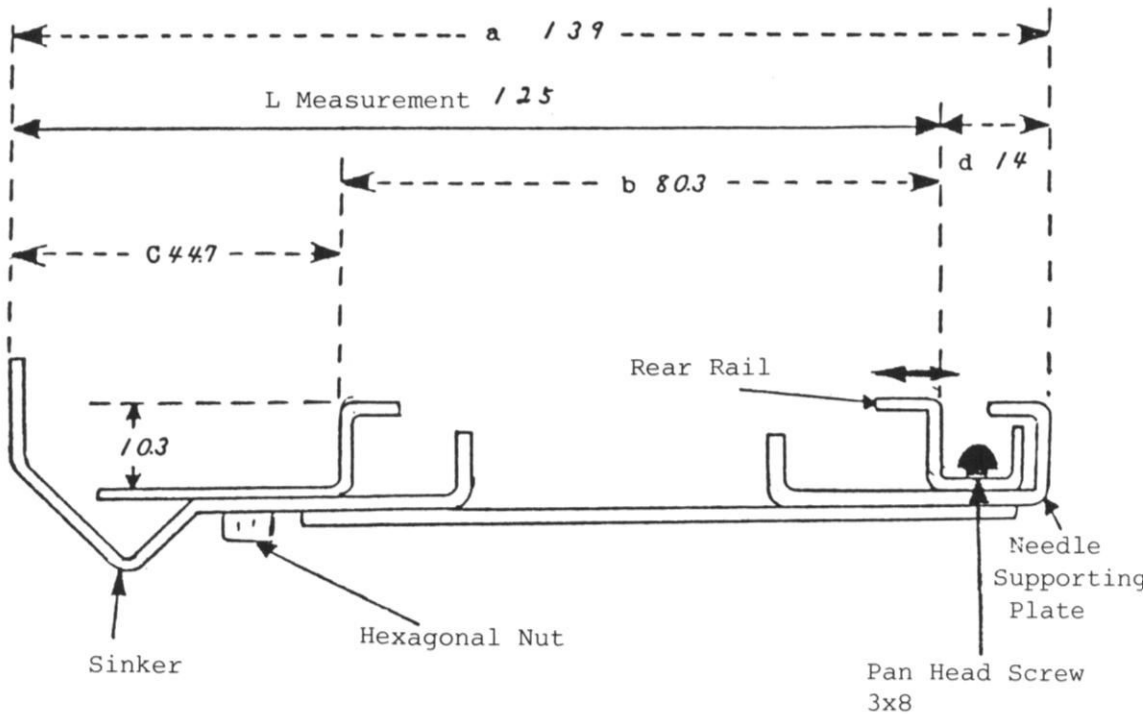

## How to adjust the measurements of the needle bed

1. To adjust the measurement "d", loosen the pan head screw 3x8 fixing the rear rail and the needle supporting plate, then move the rear rail forward or backward till the required measurement is obtained.
2. Before adjusting the L measurement, you have to confirm the "d" measurement, then loosen the hexagonal nut securing the Sinkers, and move it backward or forward to have the L measurement into correct one.

Note: In this adjustment, if the C measurement is adjusted while confirming the "b" measurement, the L measurement is automatically obtained.

