



# MACHINE KNITTING

# fashion

## UNDER THE INFLUENCE OF WARHOL

*Super designs  
inspired by Andy  
Warhol!*

## BEGINNERS

*Buttonholes and the  
Knitleader!*

## BEST DRESSED BABY

*Pretty as a peach!*

## CROCHET - STEP-BY-STEP

*More than a finishing!*

## FASHION FORECAST

*What's in store for  
the coming season!*

**36** items  
to knit

ISSN 0956-4039



9 770956 403002



Issue No. 6 £2.95

1 £4.95, N KR 150, F MK 50, CAN \$12.95



Dear Readers,

Until recently crochet never really excited me. I adore those wonderful table clothes, bedspreads, and cafe curtains etc. but crochet being worn left me cold - especially bright yellow bikini's! Over the last few years, I have noticed that top fashion designers have used crochet in a number of very interesting ways and so inspired me to have a serious rethink. We have often used crochet to finish off a neckline here, and work a button loop there, and where would we be without it when it comes to those awkward hemlines! What we have never done is used crochet as an integral part of the garment, and so, this issue, we explore the possibilities of doing just that. If, like me, you have never crocheted anything more than a simple edging, follow the instructions slowly and carefully. They may look confusing at first, but once you have the Crochet Hook in your hand it soon all falls into place!

Another first, is the way we have represented the intarsia designs - see the Stitch Pattern Sheets. Each square represents .5 of a square centimetre. If you want to save time, or find drawing out the shapes to scale difficult, take the book to a photocopying bureau and ask them to increase the size by 100% to get the shapes back to life size.

By far the best way of working intarsia is by using the Knitleader. This avoids the need to follow complicated and confusing charts. The garment pieces may be drawn onto the Sheet as well as the "picture", or the knitleader may be used for the "picture" alone, leaving you to follow the written instructions if you want to. Also if you want a garment with a difference, the Knitleader enables you to easily work the garment pieces on the diagonal - Beginners see our Step-by-Step!

Happy Knitting,

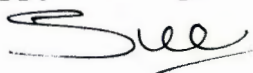

Susan Nutbeam  
Managing Editor

# CONTENTS



## SPECIAL FEATURES

**INFLUENCIA MEXICANA** – South American countries still have a big influence on fashion. This issue it is Mexico that inspires us, 4, 5, 6, 7, 8, 9

**CROCHET** – good finishing makes all the difference. Learn just a few stitches to enhance your knitwear, 10, 11, 12, 13

**UNDER THE INFLUENCE OF WARHOL** – fairisle and intarsia are used to recreate the work of an interesting artist, 20, 21, 22, 23

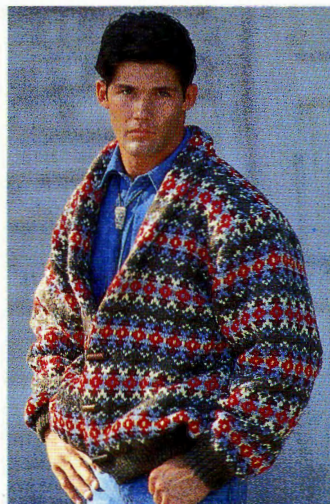

## REGULAR FEATURES

**FASHION REPORT** – Top Flight Fashion is the theme interpreted two ways, 16, 17

**STITCH LIBRARY** – using our basic shape select either intarsia or fairisle for a very special Design from the Deep, 30, 31

## MENSWEAR

**CHUNKY JACKET** – the simple way to work a shawl collar, 5

**FAIRISLE SWEATER** – our version of Andy Warhol's Coca-Cola Bottles, 21





## BABY KNITS

**SWEATER, CARDIGAN, DRESS, VEST, LEGGINGS AND ROMPERS TOO** – pretty as a peach using the Garter Carriage, 14, 15

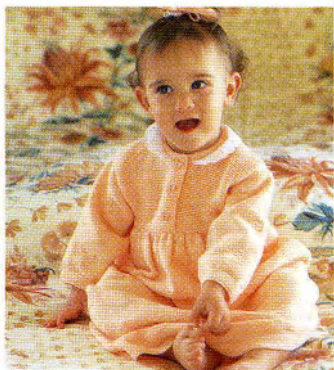

## WOMENSWEAR

**CHUNKY JERKIN** – simply stunning, 4 and Front Cover

**COTTON JACKET** – using the Knitleader, a classic shape can be transformed, 6

**WRAP-OVER SKIRT SUIT** – exotic enough for a special vacation, 7

**MEXICAN DESERT** – fairisle gives the whole picture, 8

**SPIDER PLANTS** – fairisle sweater in black and gold, 9

**CARDIGAN** – with crochet front bands, 11

**SHORT SLEEVED SWEATER** – pretty crochet inset, 11

**SQUARE NECKLINE SWEATER** – crochet yoke and cuffs, 13

**SINGLE MOTIFS** – a face famous for longer than fifteen minutes, 20

**SHOES** – smart but casual, inspired by Andy Warhol, 22

**INTARSIA** – casual cotton, 26

**JIGSAW PIECES** – simple intarsia in black or white, 26

**WINDMILLS** – single motifs, 27

**SIMPLE STRIPES** – easy to make and wear, 27

**INTARSIA AND FAIRISLE TOGETHER** – classic shape with Tulips in intarsia, 27

**STRIPES WITH A TWIST** – work in simple stripes or intarsia, 28

**SOMETHING FISHY** – take a classic shape from the deep, 30

**BRIGHT COLOURS** – update a cardigan, 34

**SINGLE MOTIFS** – decorate a basic shape, 35

## STEP-BY-STEP

**CROCHET** – simple necklines may be finished with a fancy crochet stitch or you may choose to work whole areas of your knitwear in crochet – we show you how it's done, 10, 11, 12, 13

**USING THE KNITLEADER** – once you have mastered the Knitleader you will never look back! Use your favourite shape and stitch together without any tedious calculations, 24, 25

**BUTTONHOLES** – we use two different types of buttonholes which are used on garments featured this issue, 32, 33

## KIDDIE KNITS

**GUNS IN FAIRISLE** – Boys sweater inspired by Andy Warhol, 21

**INTARSIA SWEATER** – Graphics to be worn, 23

**STRIPES WITH A TWIST** – perfect for the fashion conscious young man, 29

**STRIPES AND/OR INTARSIA** – Girl's skirt suit in comfortable cotton with classic lines, 29



Club News, Editor's Letters, an introduction to knitting instructions, etc., are to be found in the black and white centre section.

©All patterns, printed matter and photographs contained in this magazine are and remain the copyright of BROTHER INDUSTRIES LTD and BROTHER INTERNATIONAL EUROPE LTD and may not be reproduced in whole or in part without the consent of the copyright holder.

*Machine Knitting Fashion* is published jointly by BROTHER INDUSTRIES LTD, 35,9-chome, Horita-Dori, Mizuho-ku, Nagoya 467, Japan, and BROTHER INTERNATIONAL EUROPE LTD, Shepley Street, Guide Bridge, Audenshaw, Manchester M34 5JD. Tel: 061 330 6531. *Machine Knitting Fashion* cannot accept any responsibility for unsolicited manuscripts and photographs and whilst every care is taken to ensure the accuracy of the patterns, charts, drawings and editorial matter printed in this issue of *Machine Knitting Fashion*, the publisher can accept no responsibility whatsoever for any damage, loss or the like arising from their use. We reserve the right to publish and edit any letters received.



# INFLUENCIA MEXICANA

The South American influence is still dominant in the fashion world this season. We have chosen to concentrate on the Mexican/American border – a cross between the Wild West and Indian folklore. Team our unisex jerkin or jacket with well-worn denim, leather belts and boots, cowboy style. Knitted on the wide gauge machine every single stitch plays an important part in the mix of colours. The shawl collar and facing is knitted in one piece giving a professional as well as comfortable finish to the garments.



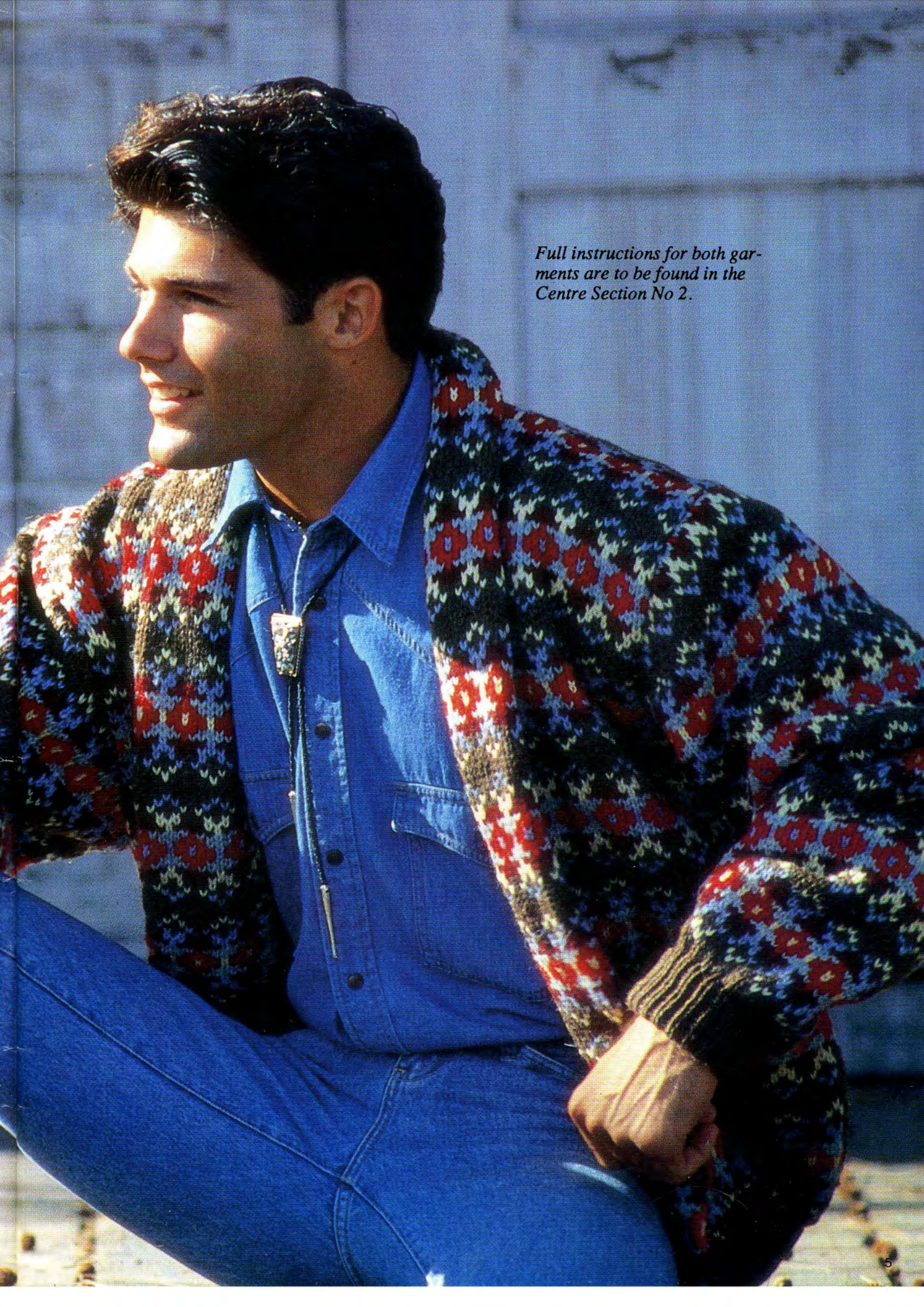

A man with dark, wavy hair is shown in profile, looking towards the left. He is wearing a vibrant, multi-colored patterned sweater over a blue button-down shirt and blue jeans. A large, ornate silver bolo tie is worn around his neck. The background is a light-colored, textured wall. The lighting is bright, suggesting an outdoor setting.

*Full instructions for both garments are to be found in the Centre Section No 2.*



# INDIAN SUMMMER

Indian design and colours influence this stunning cotton cardigan. The garment is worked using the Knitleader – the pattern pieces being placed onto the Knitleader Sheet at an angle. In this way, the chevron effect of the “yoke” is created simply by striping the colours. To add a Mexican touch decorate the yoke with tassels. A Step-by-Step account of how to use the Knitleader to achieve designs like this one is featured on pages 24 and 25. *Full instructions are to be found in the Centre Section No 5.*



Cool, exotic, off the shoulder. This simple two-piece is an ideal garment to take on vacation. The wrap-over skirt has a shaped hem and is knitted sideways. The top is knitted using the Ribbing Attachment.

*Full instructions are to be found in the Centre Section No. 3.*







# Golden Hot Deserts!

The hot, strong, yellow sun of the desert inspired these striking sweaters. Both are worked on Brother electronic knitting machines using the automatic fairisle patterning. The Mexican scene on the left requires patterning facility across 200 needles, the finishing touches are then embroidered. *Full instructions are given in the Centre Section No. 1.*

The spider plant design on the right is worked across 60 needles. *Full instructions are given in the Centre Section No. 4.*











# CROCHET

*more than a finishing touch!*

## BEGINNERS – STEP-BY-STEP

Over the last few years top fashion designers have used a smattering of Crochet in their collections. Sometimes as a decorative edging, sometimes as an inset panel or patch pocket etc., and sometimes the whole garment has been worked in Crochet. Crochet has not been restricted to any particular type of garment, on the contrary it has been used across the whole spectrum of fashion – with denim and leather for outer garments and with chiffon and silk for evening wear. Most interestingly it has not even been restricted to women's wear – menswear has seen a crop of Crochet waistcoats etc.

Machine knitters tend to use Crochet for an edging or button loops and not consider using it as a main design feature. And so, to whet the appetite,

we have produced three garments where Crochet is used together with stocking stitch for a truly feminine look!

If you have never learned to Crochet, try it! You will be investing your time wisely – even if you choose only to use it for edging. Crochet may look difficult but it is made up of surprisingly few stitches and can be mastered very quickly.

We have used Filet Crochet for the yoke, V-inset and Front Bands of our garments. Stitches used are exactly the same except that they are worked into a series of blocks and spaces using Trebles and Chains to form a mesh, full instructions for the Filet Crochet are given with each set of knitting instructions.

### STEP 1. THE INITIAL LOOP AND CHAIN STITCH

A. The Initial Loop simply gives you a basis to work from – wrap the yarn around the Crochet Hook as illustrated firmly but not tightly.

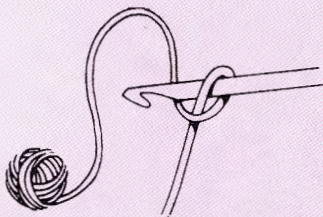

B. Wind the yarn once around the Crochet Hook and then using the hook pull it through the Initial Loop.

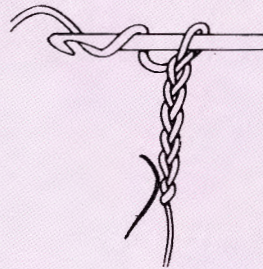
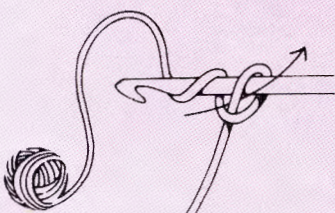

C. By continuing to work in this manner the Chain is formed.

### STEP 2. DOUBLE CROCHET

Once you have a Chain there are various ways of building onto it.

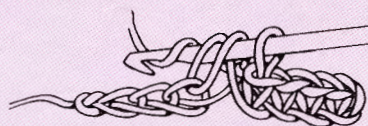

To work the Double Crochet stitch (dc) \*keeping the last loop of the Chain on the Crochet Hook, push the

Crochet Hook through the centre of the next Chain. Wind the yarn once around the Crochet Hook and draw the loop through the Chain – you now have 2 loops on the Crochet Hook. Wind the yarn around the Crochet Hook once and draw the loop through the 2 loops on the Crochet Hook to form 1 loop.\* Repeat from \* to \* throughout.

### STEP 3. HALF TREBLE

To work the Half Treble \*keeping the last loop of the Chain on the Crochet Hook, wind the yarn around the Crochet Hook, push the Crochet Hook through the centre of the next Chain. Wind the yarn once around the Crochet Hook, draw through the Chain – there are 3 loops on the Crochet Hook. Wind the yarn once around the Crochet Hook and draw through all 3 loops on the Crochet









Previous page and above – The V-neck cardigan features Crochet Front Bands and Crochet Button Loop – full instructions are to be found in the Centre Section No 6. The short sleeved sweater features a Crochet V-shaped inset and a slash back opening – full instructions are to be found in the Centre Section No 7.

Opposite page – Crochet is used for the yoke and cuffs – full instructions are to be found in the Centre Section No 8.

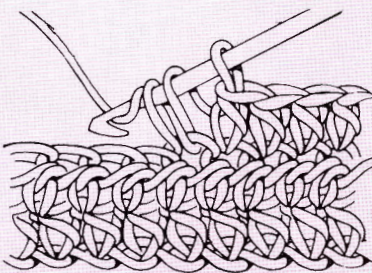

Hook leaving just 1 loop.\* Repeat from \* to \* throughout.

#### STEP 4. TREBLE CROCHET

To work Treble Crochet \*keeping the last loop of the Chain on the Crochet Hook, wind yarn once around the Crochet Hook, push the Crochet Hook through the centre of the next Chain. Wind the yarn once around the Hook, draw the last loop through the Chain – you now have 3 loops on the Crochet Hook. Wind yarn once around the Crochet Hook and then draw through the first 2 loops on the Crochet Hook. Wind yarn once around the Crochet Hook and then draw through the remaining 2 loops to form 1 loop.\* Repeat from \* to \* throughout.

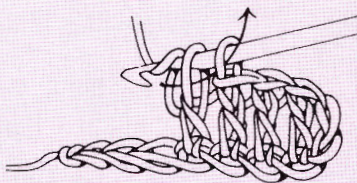
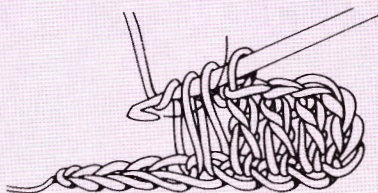

#### STEP 5. SLIP STITCH

To work Slip Stitch \*keeping the last loop of the Chain on the Crochet Hook, push the Crochet Hook through the centre of the next Chain.



Wind the yarn once around the Hook, draw it through the Chain and the loop on the Crochet Hook to give you 1 loop.\* Repeat from \* to \* throughout.

#### STEP 6. PICOT EDGING

Picot Edging is formed by loops of 3 or 4 Chain stitches caught into a circle by working a Slip Stitch into the 3rd or 4th Chain from the hook.

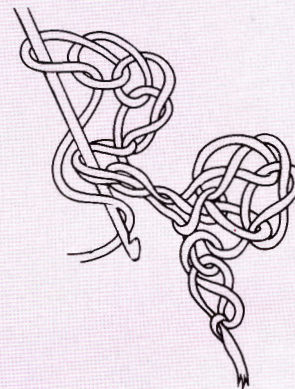

#### STEP 7. CRAB STITCH

Work 1 row of Double Crochet (from right to left) as above. DO NOT TURN. Now work 1 row of Double Crochet from LEFT to RIGHT.

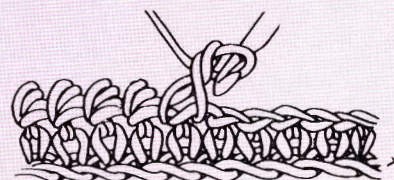

We would like to thank Twilleys of Stamford Ltd., for kindly letting us reproduce diagrams etc. Twilleys produce a number of crochet books which will be of interest to crochet lovers of all standards, contact: – Twilleys of Stamford Ltd, Roman Mill, Stamford, Lincolnshire PE9 1BG.



n  
T  
e



Alison Neill '90

...ele...ele...



# *Pretty as a Peach*

Sometimes, when an attractive accessory is found it is an interesting exercise to design around it – a pretty button inspired this range of baby garments! Using only one colour the texture of the fabric produced is the all important feature. However, as we show here, the stitch design doesn't have to be complicated to give good results. We have used the Brother Garter Carriage which produces a fabulous range of textured stitches including, of course, garter stitch, which, being reversible, is excellent for the vest and leggings.





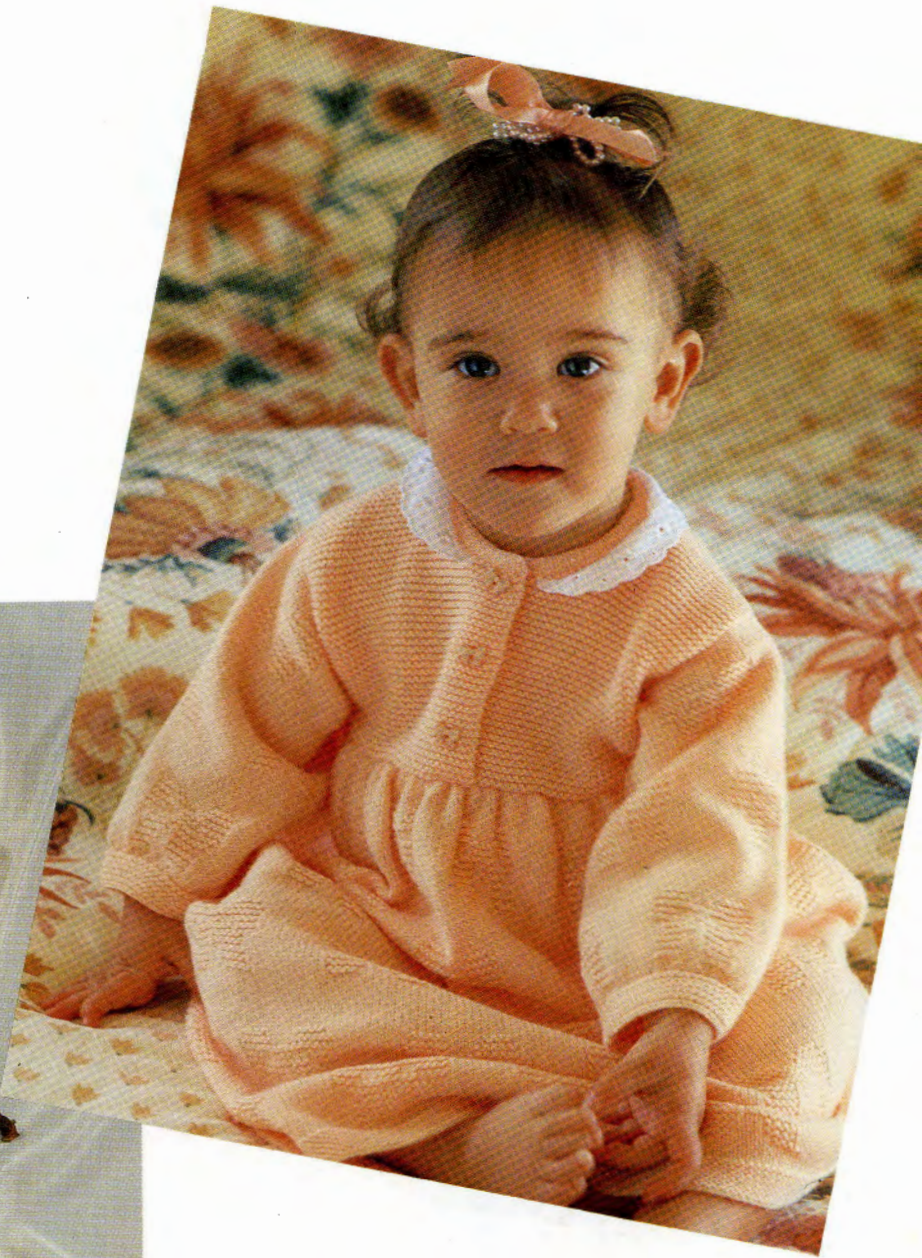

*Full instructions for all garments are to be found in the Centre Section No 9.*



# TOP FLIGHT FASHION!

Aviation, is one of the themes taken up by designers for this autumn. All age groups and tastes will be catered for, from sophisticated city folks to kids. This theme can be interpreted in many different and exciting ways, the underlining tone being of romance and glamour from Hollywood.

We tell the story in two chapters. First, timeless masculine elegance for the career woman – “Battle dressing” with charm. Colours are cool and confident, blues of all shades, steel, Air Force, teal, navy, together with ink, grey, charcoal, silver, purple, with touches of claret. Fabrics favoured are gabardine, twill, serge, whipcord,







denim, and glazed cotton fabrics in shirting stripes, teamed with soft woollen ribbed knits with marl effects. The garments to watch for are safari type suits, blazers, culottes, classic pleated pants, cigarette pants and overcoats. For the finishing touch add a military brooch, metallic braiding and gold or silver buttons. Wear red nail polish and lipstick to complete the feeling of clean sophisticated lines with glamour. The simple stylish look in knitwear is plain colours in self pattern – cables or stitches using the Garter Carriage!

The second part of the story we feel sure will be taken up by those who love natural colours and textures – silk, leather, wool, brass, pewter and gold. Also by the young, who are captivated by the romance of the pilots who wore brown leather jackets with silk scarves and customized their aircraft with pictures of pin up girls – a further influence from North America. They will decorate their denim – of blue or brown – with air travel memorabilia. Colours include dark blues and grey together with khaki, brown, chocolate and taupe. Gold and brass is used to decorate.



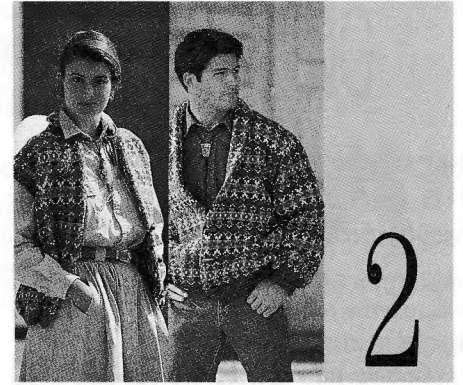
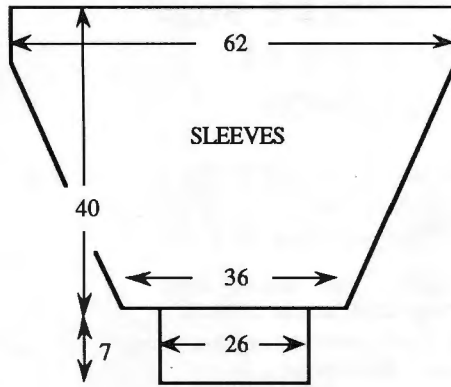
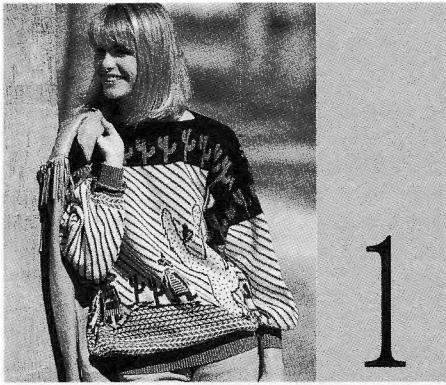

**MACHINES:** D with KR. **MATERIALS:** PAMELA WISE 4 Fold Cotton, Quality 8046; M - 330g (Yellow 55), A - 220g (Bottle 67), B - 125g (Brown 64), C - 60g (Cream 35), D - 140g (Black 49), E - 55g (Green 42). (100% cotton 300m/100g). Small amounts of Red, Royal, Orange and Turquoise for swiss darning and embroidery. **MEASUREMENTS:** One size fits up to bust 106cm. **TENSION:** Fairisle St Patt - 40 sts = 13.1cm and 60 rows = 17.5cm (approx T9). **RIB:** 1 x 1 T2/2. **NOTES:** See Stitch Pattern Sheet Nos 1, 2, 3 and 4.

**BACK**

Using B cast on over 193 KH Ns as RIB, 000. Knit to RC30. Trans all sts to KH. T9 set for first row of Fairisle St Patt No 1 and knit 1 row to select Ns,

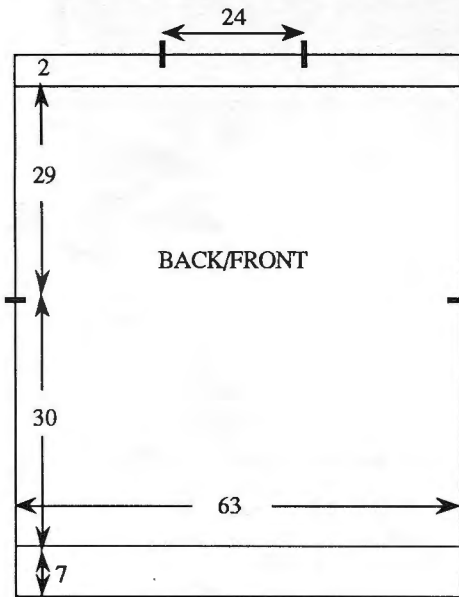

000. With B in FA and C in FB knit to RC24. With M in FA and A in FB knit to RC103. Place a WY marker at each end of work. Knit to RC168. Using D knit 2 rows. With D in FA and E in FB knit to RC201. Using D knit 2 rows. Trans to RIB and knit to RC212. T10/8 knit 1 row. Trans all sts to KH and latch cast off.

**FRONT**

As BACK except activate Reverse function.

**SLEEVES**

Join shoulders leaving open 24cm at centre. Push 189 KH Ns into WP. With wrong side facing, pick up same number of sts evenly along armhole edge between WY markers and place onto Ns. Set for Stitch Patt No 1 to knit upside down. T9 using D knit 1 row to select Ns, 000. With D in FA and E in FB knit to RC20. Dec 1 st at each end of next and every foll 3rd row x 39 and, AT THE SAME TIME, work colour changes as follows: RC31, using D knit 1 row. Set for first row of Fairisle St Patt No 2 [see Stitch Patt Sheet 4(A)] and knit 1 row to select Ns. With M in FA and A in FB knit to RC127, set for first row of Fairisle St Patt No 1 and knit 1 row to select Ns, with B in FA and C in FB knit to RC137, using B knit 1 row. Waste knit rem 111 sts. **CUFFS:** Push 79 KH Ns into WP. With wrong side facing, place sts from cuff edge onto Ns distributing them evenly along the row. Using B T9 knit 1 row. Trans to RIB, 000. Knit to RC29. T10/8 knit 1 row. Trans all sts to KH and latch cast off.

**MAKE-UP**

Join side and SLEEVE seams. Swiss darn and embroider as illustrated.

**MACHINES:** B2 and KR. **MATERIALS:** JAMIESON AND SMITH 2-Ply Soft Spun; JACKET [L] M - 225 (250, 275, 300, 325, 350)g (BSS14 Brown), 90g in each of A - (BSS20 Lemon), B - (BSS2 Blue), C - (BSS25 Maroon), D - (BSS1 Pale green), E - (BSS21 Scarlet). [M] M - 275 (300, 325, 350, 375, 400)g, 120g in each of A, B, C, D and E. JERKIN [L] M - 185 (200, 220, 240, 260, 280)g (BSS26 Khaki), 60g in each of A, B, C, D and E. [M] M - 230 (250, 270, 290, 310, 330)g, 90g in each of A, B, C, D and E. (100% Wool. 194m/100g). 3 Buttons. **MEASUREMENTS:** To fit bust/chest 86 (91, 96, 101, 106, 111)cm. **TENSION:** Fairisle St Patt - 20 sts = 11.7cm and 30 rows = 15cm (approx T8). **RIB:** 1 x 1 T1/1. **NOTES:** See Pattern Sheet No 6(C). [L] preceding refers to Lady's sizes and [M] preceding refers to Man's sizes. Fairisle St Patt:

FA	FB	No of rows
M	A	2
M	B	"
C	B	"
D	E	"
A	E	"
D	E	"
C	B	"
M	B	"
M	A	"
M only		"
M	B	"
M	A	"
C	A	"
D	E	"
B	E	"
D	E	"
C	A	"
M	A	"
M	B	"
M only		"



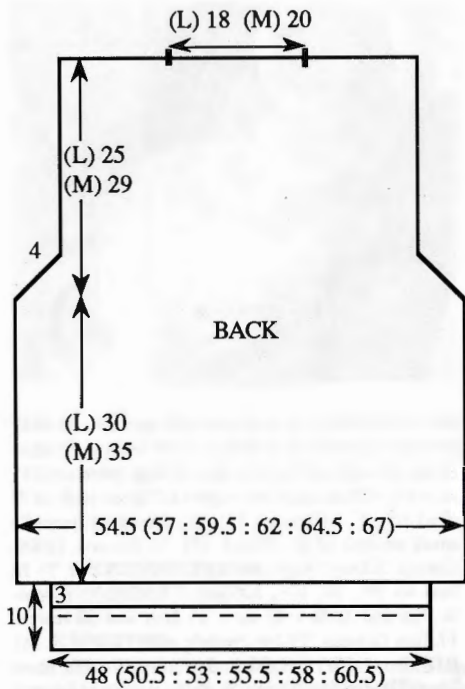

### JACKET - BACK

Using WY cast on over 93 (97, 101, 105, 109, 113) KH Ns and knit a few rows ending with COR. \*Using M T8 knit 1 row, 000. Knit 1 row. Set for first row of Fairisle St Patt and knit 1 row to select Ns. Working in Fairisle Patt throughout knit to RC28. Place a WY marker at each end of work. Knit to [L] RC60, [M] RC70\*.

### Armhole shaping

At beg of next 2 rows cast off 2 sts. Dec 1 st at each end of next and every foll alt row x 5. Knit to [L] RC110, [M] RC128 and waste knit. **WAIST RIB:** Push 81 (85, 91, 95, 99, 103) KH Ns into WP. With wrong side facing, place sts from waist edge onto Ns distributing them evenly along the row. \*\*Using M T8 knit 1 row. Trans to RIB, 000. Knit to RC29. T10/8 knit 1 row. Trans all sts to KH and latch cast off.\*\*

### LEFT FRONT

Using WY cast on over 76 (78, 80, 82, 84, 86) KH Ns and knit a few rows ending with COR. Repeat

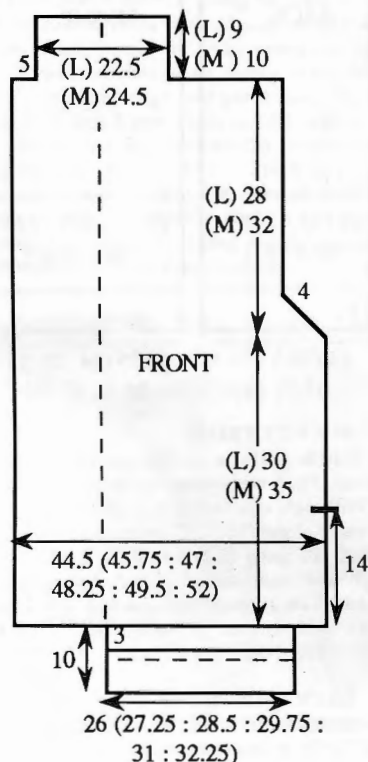

from \* to \*, except place a WY marker at left end only.

### Armhole shaping

COL, at beg of next row cast off 2 sts, knit 1 row. At left on next and every foll alt row dec 1 st x 5. Knit to [L] RC115, [M] RC133. At left waste knit [L] 24 (26, 28, 30, 32, 34) sts, [M] 22 (24, 26, 28, 30, 32) sts for shoulder, COR. At beg of next row cast off 8 sts. Collar: Knit to [L] RC134, [M] RC154 and waste knit rem [L] 37 sts and [M] 39 sts. **WAIST RIB:** Fold [L] 26, [M] 27 sts to inside to form the facing. Push 43 (45, 47, 49, 51, 53) KH Ns into WP. With wrong side facing and working from centre front (fold line) place 2 sts (one from facing and one from FRONT) onto 1 N across the first [L] 26, [M] 27 Ns, then distribute rem sts evenly along the row. Repeat from \*\* to \*\*.

### RIGHT FRONT

As LEFT FRONT reading right for left and vice versa and, AT THE SAME TIME, at RC1, 21, and 41, counting from the left, work 2 x 2 st buttonholes over Ns 22 and 23, 32 and 33. Join Collar seam by placing sts back onto Ns with right sides together. Using appropriate col T10 knit 1 row and cast off.

### SLEEVES

Using WY cast on over [L] 45 KH Ns, [M] 60 KH Ns and knit a few rows. Using M T8 knit 1 row, 000. Knit 1 row. Set for first row of Patt and knit 1 row to select Ns. Working in Fairisle St Patt throughout knit to [L] RC3, [M] RC4. Inc 1 st at each end of next and every foll [L] 3rd, [M] 4th row x [L] 23, [M] 22. Knit to [L] RC80, [M] RC90.

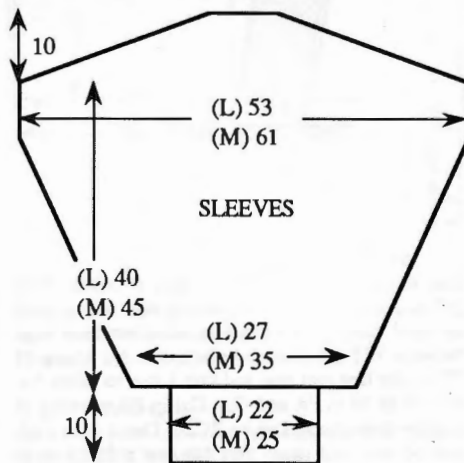

### Sleeve head shaping

At beg of next and every row cast off 4 sts x 20. Cast off rem [L] 11 sts, [M] 24 sts. **CUFFS:** Push [L] 37, [M] 43 KH Ns into WP. With wrong side facing, place sts from CUFF edge back onto Ns distributing them evenly along the row. Repeat from \*\* to \*\*.

### POCKET BAGS (2)

Using M COBH 24 sts, 000. Knit to RC28 and cast off.

### MAKE-UP

Push 79 (83, 87, 91, 95, 99) KH Ns into WP. With right side of BACK facing place sts back onto Ns. With wrong side of FRONTS facing place shoulder sts onto corresponding Ns. Pick up sts from under side of COLLAR and place onto Ns. Using M T10 knit 1 row and cast off. Slip st top side of COLLAR to neck edge. Block and press. Set in SLEEVES to armholes. Stitch one side of POCKET BAG to BACK between WY marker and top of WAIST RIB. **POCKET RIB:** Push 25 KH Ns into WP. With wrong side facing, pick up same number of sts evenly along FRONT side seam between WY marker and top of WAIST RIB and place onto Ns. Using M T8 knit 1 row. Trans to RIB, 000. Knit to

RC5. T10/8 knit 1 row. Trans all sts to KH and latch cast off. Join side and SLEEVE seams. Stitch POCKET BAGS to garment. Fold WAIST RIBS and CUFFS in half to inside and catch down loosely. Attach buttons.

### JERKIN BACK AND FRONTS

As JACKET, EXCEPT knit 10 rows only for WAIST RIBS and omit pockets.

### ARMBANDS

Push [L] 91, [M] 104 KH Ns into WP. With wrong side facing, pick up same number of sts evenly along armhole edge and place onto Ns. Using M T8 knit 1 row. Trans to RIB, 000 knit to RC9. T10/8 knit 1 row. Trans all sts to KH and latch cast off.

### MAKE-UP

Block and press. Join side seams. Attach buttons.



**MACHINES:** A, C or D with KR. **MATERIALS:** ATKINSON YARN DESIGNER COLLECTION Bangkok; M - 450 (470, 490, 510, 530)g (Tan 13) (88% Acrylic, 12% Nylon 1500m/100g). 2.5cm wide Petersham to fit waist of skirt. Velcro. **MEASUREMENTS:** To fit bust 86 (91, 96, 101, 106)cm. Skirt - One size to fit up to hip 111cm. **TENSION:** St st - 40 sts = 15.4cm and 60 rows = 12.5cm (approx T6). 2 x 1 Rib (see Abbreviations) 40 sts = 12cm and 60 rows = 10.3cm (approx T2/2). **NOTES:** Unless otherwise stated, 2 ends of yarn are used throughout. When shaping, count Ns on KH as sts and adjust sts on KR as necessary.

### SKIRT

Working from left to right from the 84th N to left of '0', using M COBH over 120 KH Ns, COR, 000. T6 knit to RC16. \* Disconnect RC. Inc 1 st at right end of work. (Always taking yarn round inside N to prevent a hole forming). Set K-Carr to H, at left on next and every foll alt row push into HP 20 Ns x 2, then push into HP groups of 13 Ns adjusting last group to fit until all Ns are in HP. Inc 1 st at right end of work. Take back to UWP the same groups adjusting last group to fit until only 20 Ns at left are in HP. Inc 1 st at right end of work. Reconnect RC. Set K-Carr to N and knit 16 rows over all Ns \*. Repeat from \* to \* x 16 [RC272. 168 sts]. Repeat from \* to \* without inc any sts x 6 [RC368]. Repeat from \* to \* dec sts instead of inc x 16 [RC624. 120sts]. Cast off loosely.

### WAISTBAND

Using WY cast on over 200 KH Ns and knit a few rows, 000. Using M T6 knit to RC24. Turn up hem and knit 1 row. With wrong side facing, pick up same number of sts evenly along waist edge and place onto Ns. T10 knit 1 row and cast off.

### MAKE-UP

Cut a length of Petersham: waist measurement plus 20cm, and thread through WAISTBAND. Press SKIRT. Attach Velcro to WAISTBAND.

### TOP BACK

Using M cast on over 137 (146, 152, 161, 167) KH Ns as RIB, 000. Knit to RC134 (140, 146, 152, 158).



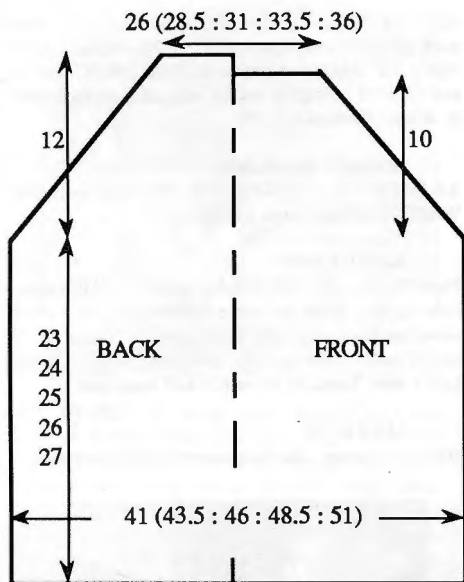

#### Armhole shaping

Cast off 3 sts at beg of next 2 rows. Dec 1 st at each end of next and every foll alt row x 21. Knit to RC206 (212, 218, 224, 230). Trans all sts to KH. T6 knit 1 row and waste knit.

#### FRONT

As BACK to RC192 (198, 204, 210, 216). Trans all sts to KH. T6 knit 1 row and waste knit.

#### COLLAR

Using WY cast on over 130 KH Ns and knit a few rows, 000. T6 Using M knit to RC124 (136, 148, 160, 172). Place a WY marker at right end of work. Knit to RC196 (208, 220, 232, 244). Place a WY marker at right end of work. Knit to RC320 (344, 368, 392, 416). Place a WY marker at right end of work. Knit to RC392 (416, 440, 464, 488) and waste knit.

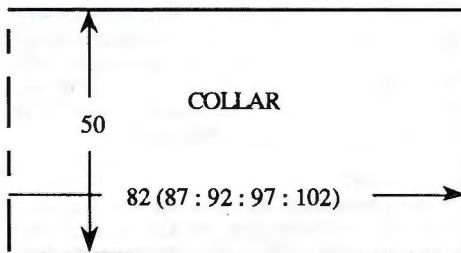

#### MAKE-UP

Join ends of COLLAR to form a circle by placing sts back onto Ns with right sides together. T10 knit 1 row and cast off. Push 89 (98, 104, 113, 119) KH Ns into WP. With right side facing, place sts from neck edge of BACK onto Ns. With wrong side facing, pick up same number of sts evenly along side edge of COLLAR between cast off edge and first WY marker and place onto Ns. T10 knit 1 row and cast off. Repeat for FRONT picking up sts between the rem WY markers. Join side seams.

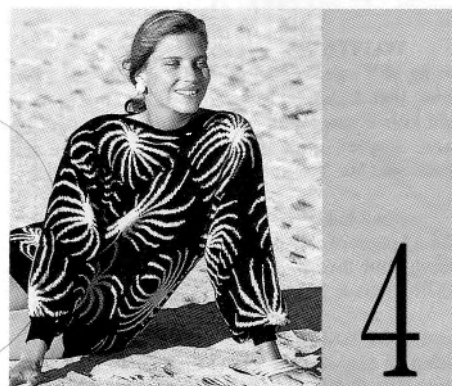

**MACHINES:** C or D with KR. **MATERIALS:** ATKINSON YARNS DESIGNER COLLECTION Wharfedale; M - 300 (320, 340, 360, 380)g (Black 11089), Con Col - 175 (190, 205, 220, 235)g (Dandelion 11109). (45% acrylic 30% nylon 25% wool 475m/100g). **MEASUREMENTS:** To fit bust 86 (91, 96, 101, 106)cm. **TENSION:** Fairisle St Patt - 40 sts = 14.5cm and 60 rows = 15.7cm (approx T8). **RIB:** 1 x 1 T2/2. **NOTES:** See Stitch Pattern Sheet Nos 5(A) and 6(B).

#### BACK/FRONT

Using M cast on over 145 (153, 159, 167, 173) KH Ns as RIB, 000. Knit to RC35. Trans all sts to KH. T8 set for first patt row and knit 1 row to select Ns, 000. With M in FA and Con Col in FB working in fairisle throughout, knit to RC114. Place a WY marker at each end of work. Knit to RC220. Using M knit 1 row. Trans to RIB, knit to RC230. T10/8 knit 1 row. Trans all sts to KH and latch cast off.

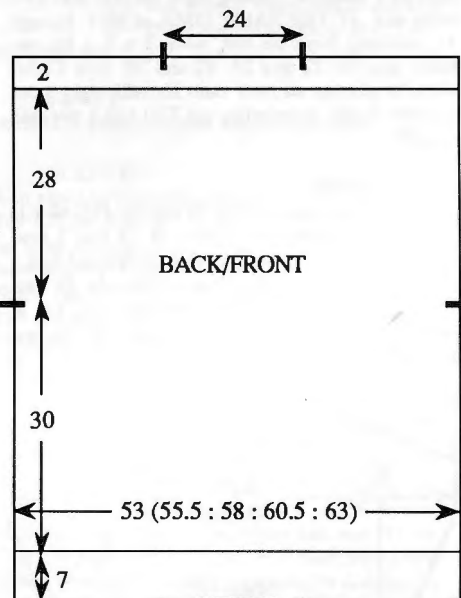

#### SLEEVES

Join shoulders leaving 24 cm open at centre. Push 165 KH Ns into WP. With wrong side facing, pick up same number of sts evenly along armhole edge between WY markers and place onto Ns. Using M T8 set for first patt row and knit 1 row to select Ns, 000. With M in FA and Con Col in FB working in fairisle throughout, knit to RC20. Dec 1 st at each end of next and every foll 4th row x 33. Knit to RC152 and waste knit rem 99 sts. **CUFFS:** Push 71 KH Ns into WP. With wrong side facing, place sts from CUFF edge back onto Ns distributing them evenly along the row. Using M T8 knit 1 row. Trans to RIB, 000. Knit to RC35. T10/8 knit 1 row. Trans all sts to KH and latch cast off.

#### MAKE-UP

Block and press. Join side and SLEEVE seams.

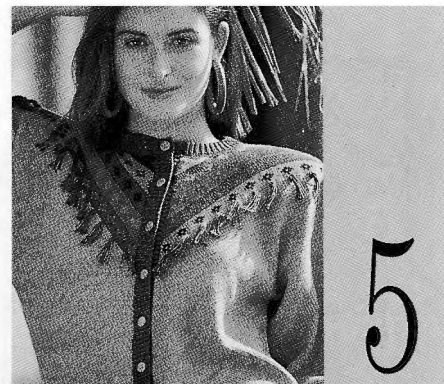
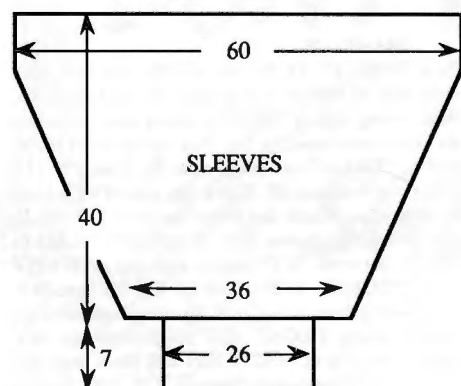

**MACHINES:** A, C or D with KL and KR. **MATERIALS:** PAMELA WISE 4 Fold Cotton, Quality 8046; M - 550 (570, 590, 610, 630)g (Mustard 17), A - 75g (Chocolate 64), approx 50g in each of B (Red 65), C - (Orange 44), D - (Bottle 67), and a small amount of E - (Black 49). 10 Buttons. (100% Cotton 300m/100g). **MEASUREMENTS:** To fit bust 86 (91, 96, 101, 106)cm. **TENSION:** Fairisle St Patt and St St - 40 sts = 13.8cm and 60 rows = 17.1cm (approx T9 for Fairisle and T10 for St St). **RIB:** 1 x 1 T3/3. **NOTES:** See Stitch Pattern Sheet No 6(D). Fairisle/Stripe St Patt - Using colours at random knit 2 rows st st, 5 rows Fairisle, 2 rows st st.

#### PROCEDURE (see STEP-BY-STEP)

Make a tension swatch and set KL accordingly. Make a paper pattern of one FRONT and half BACK. Trace onto KL sheet diagonally. Draw a horizontal line from shoulder point to centre FRONT/BACK to indicate start of Fairisle Yoke. Draw a line in the same direction as knitting to indicate POCKET opening and draw a dotted line to indicate POCKET BAG. Draw in SLEEVE. Knit FRONTS and BACKS placing WY markers where indicated. Knit POCKET BAGS.

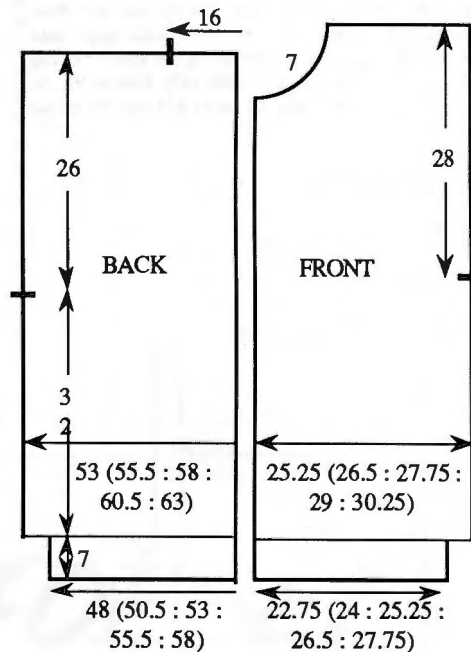

#### POCKET TRIMS

Use Stitch Scale to determine number of sts required. Push corresponding number of Ns into WP. With right side facing, pick up same number of sts evenly along POCKET opening and place onto Ns, 000. T9 using M knit to RC8. Knit 1 Fairisle 'Stripe' and waste knit. Fold in half to outside and backstitch to garment through last row knitted. Attach each end to garment. Stitch POCKET BAGS to FRONTS.

#### BACK WAISTBAND

Join centre BACK seam. Block and press. Using Stitch Scale to determine number of sts required.



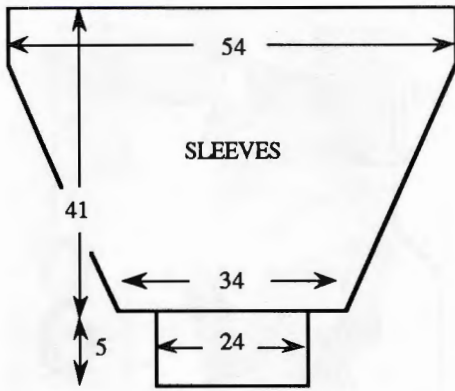

Push corresponding number of KH Ns into WP. With right side facing, pick up same number of sts evenly along BACK waist edge and place onto Ns, 000. T9 using M knit to RC26. Knit 3 Fairisle 'Stripes' and waste knit.

#### FRONT WAISTBANDS

As BACK WAISTBAND.

#### SLEEVES

Join shoulders. Following KL sheet pick up required number of sts evenly along armhole edge between WY markers and place onto Ns. Knit SLEEVES and waste knit. Block and press. CUFFS: Using Stitch Scale to determine number of sts required. Push corresponding number of KH Ns into WP. With right side facing place sts from CUFF edge onto Ns distributing them evenly along the row, 000. T9 using M knit to RC17. Knit 2 Fairisle 'Stripes' and waste knit. Block and Press.

#### NECKBAND

Using Stitch Scale to determine number of sts required. Push corresponding number of KH Ns into WP. With right side facing, pick up same number of sts evenly along neck edge and place onto Ns. Using A T9 knit 1 row. Trans to RIB, 000. Knit to RC26. Trans all sts to KH T9 knit 2 rows and waste knit. Fold in half to outside and backstitch to garment through last row knitted in A.

#### MAKE-UP

Join side and SLEEVE seams. Join WAISTBAND and CUFF seams, fold in half to outside and backstitch to garment through last row knitted in M. **BUTTONHOLE BAND:** Using St Scale to determine the number of sts required push corresponding number of KH Ns into WP. With wrong side facing, pick up same number of sts evenly along RIGHT FRONT opening edge and place onto Ns, 000. Using A T9 knit 1 row. Trans to RIB, 000. Knit to RC6. Work 10 x 2 st buttonholes evenly spaced along the row. Knit to RC12. T10/8 knit 1 row. Trans all sts to KH and latch cast off. **BUTTON BAND:** As BUTTONHOLE BAND omitting buttonholes. Attach Buttons. Using A make tassels and attach to FRONT/BACK as illustrated.



**MACHINES:** A, C or D with KR. **MATERIALS:** TWILLEYS Galaxia '5'; M - 400 (415, 430, 445,

460)g (Jade 67) (100% Acrylic 494m/100g). 1 button. **MEASUREMENTS:** To fit bust 86 (91, 96, 101, 106)cm. **TENSION:** St St - 40 sts = 11.7cm and 60 rows = 12.7cm (approx T5). **RIB:** 2 x 1 (see ABBREVIATIONS) T2/2.

#### BACK

Using WY cast on over 164 (172, 180, 188, 196) KH Ns and knit a few rows ending with COR, 000. Using M T5 knit to RC94, COR.

#### Armhole shaping

Cast off 2 sts at beg of next 2 rows. Dec 1 st at each end of next and every foll alt row x 12. Knit to RC208. At beg of next 2 rows cast off 51 (55, 59, 63, 67) sts. Cast off rem 34 sts. **WAIST RIB:** Push 131 (140, 149, 158, 167) KH Ns into WP. \*With wrong side facing, place sts from waist edge onto Ns distributing them evenly along the row. Trans to RIB, 000. Knit to RC15. T10/8 knit 1 row. Trans all sts to KH and latch cast off each st individually.\*

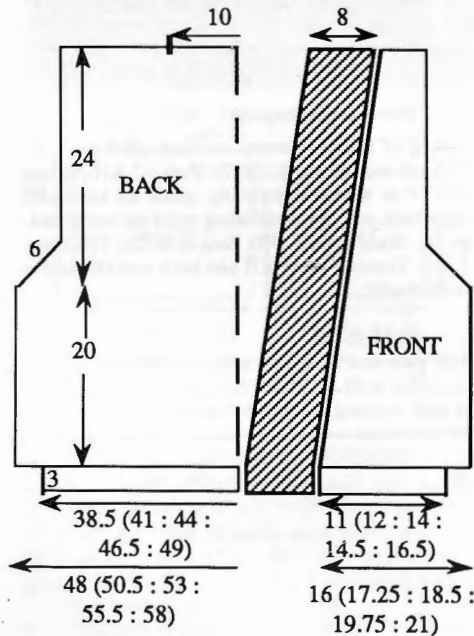

#### RIGHT FRONT

Using WY cast on over 55 (59, 63, 67, 71) KH Ns and knit a few rows ending with COR, 000. T5 Using M knit to RC14.

#### Neck shaping

At left on next and every foll 14th row dec 1 st x 14 and, AT THE SAME TIME, at RC94, COR ...

#### Armhole shaping

Cast off 2 sts at beg of next row. Knit 1 row. At right on next and every foll alt row dec 1 st x 12. Knit to RC207 and cast off rem 27 (31, 35, 39, 43) sts. **WAIST RIB:** Push 38 (41, 47, 50, 56) KH Ns into WP. Repeat from \* to \* as BACK.

#### LEFT FRONT

As RIGHT FRONT reversing shaping.

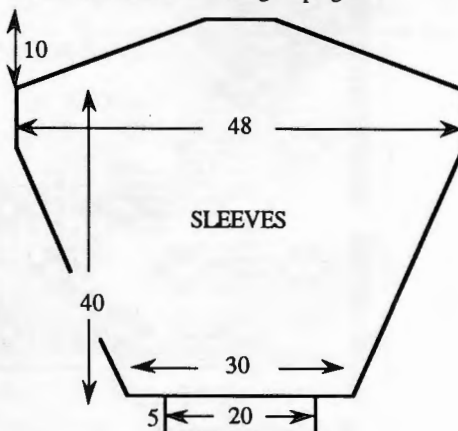

#### SLEEVES

Using WY cast on over 102 KH Ns and knit a few rows ending with COR, 000. Using M T5 knit to RC6. Inc 1 st at each end of next and every foll 6th row x 31. Knit to RC190.

#### Sleeve head shaping

At beg of next and every row cast off 3 sts x 48. Cast off rem 22 sts. **CUFFS:** Push 68 KH Ns into WP. With wrong side facing, place sts from cuff edge onto Ns distributing them evenly along the row. Trans to RIB, 000. Knit to RC29. T10/8 knit 1 row. Trans all sts to KH and latch cast off each st individually.

#### MAKE-UP

Crochet BANDS and attach to FRONTS. Join shoulders. Set in SLEEVES. Join side and SLEEVE seams. Attach button.

#### CROCHET BANDS:

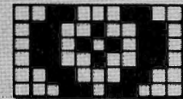

#### Button and Buttonhole Bands

Using 2mm Hook make 36 c. **Foundation row:** 1 tr into 3rd c from hook, 1 tr into each c to end. **Work from Chart as follows: 1st row:** 5 c. [1 tr into 3rd tr, 2 c] twice, 1 tr into next 7 tr, 2 c, 1 tr into 3rd tr, 1 tr into next 6 tr, [2 c, 1 tr into 3rd tr] 3 times, 5 c turn. Cont to work from CHART until Band is long enough to fit along Centre FRONT (see diagram) to Shoulders. Sew into position. **PICOT EDGING:** Work 1 row dc evenly along right FRONT, across BACK neck and down left FRONT, turn. Next row: \*3 c, ss into 3rd c, 1 dc into next 2 dc\*, repeat from \* to \* to last 4cm. **Work buttonhole as follows:** work 10 c, ss into 8th dc, turn, ss into 10 c, turn, cont picot edging to end. Fasten off.

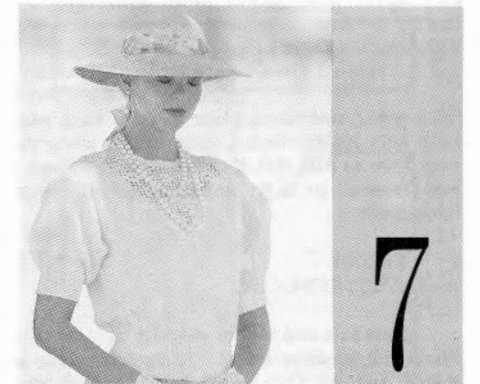

**MACHINES:** A, C or D with KR. **MATERIALS:** TWILLEYS Galaxia '5'; M - 350 (365, 380, 395, 410)g (White 50) (100% Acrylic 494m/100g). 3 buttons. **MEASUREMENTS:** To fit bust 86 (91, 96, 101, 106)cm. **TENSION:** St St - 40 sts = 11.7cm and 60 rows = 12.7cm (approx T5). **RIB:** 2 x 1 (see ABBREVIATIONS) T2/2.

#### BACK

Using WY cast on over 164 (172, 180, 188, 196) KH Ns and knit a few rows ending with COR, 000. Using M T5 knit to RC94.

#### Armhole shaping

At beg of next and every row cast off 4 sts x 2, 3 sts x 4, 2 sts x 6, then dec 1 st at each end of alt rows x 5 (7, 9, 11, 13). Knit to RC160, COR.

#### Back opening

Waste knit all sts at left of '0'. Knit to RC208 and cast off rem 61 (63, 65, 67, 69) sts. Return sts at left to Ns and knit to match right side. **WAIST RIB:** Push 131 (140, 149, 158, 167) KH Ns into WP.



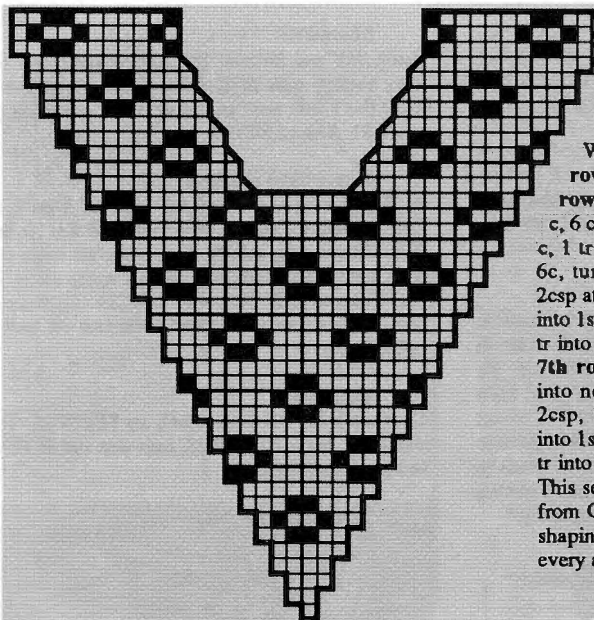

### CROCHET INSET

Using 2.5mm Hook make 5 c.  
 Work from Chart as follows: **1st row:** 1 tr into 5th c, 6 c, turn. **2nd row:** 1 tr into 1st tr, 2 c, 1 tr into 3rd c, 6 c, turn. **3rd row:** 1 tr into 1st tr, 2 c, 1 tr into next tr, 2 c, 1 tr into 3rd c, 6c, turn. Work 2 more rows inc one 2csp at beg of each row. **6th row:** 1 tr into 1st tr, 1 2csp, [2 tr into next 2csp, 1 tr into next tr] twice, 2 2csp, 6 c, turn. **7th row:** 1 tr into 1st tr, 1 2csp, 2 tr into next 2csp, 2 2csp, 2 tr into next 2csp, 1 2csp, 6 c, turn. **8th row:** 1 tr into 1st tr, 2 2csp, [2 tr into next 2csp, 1 tr into next tr] twice, 3 2csp, 6 c, turn. This sets the position of the Chart, cont from Chart until completed. Note neck shapings are worked by dec one 2csp every alt row.

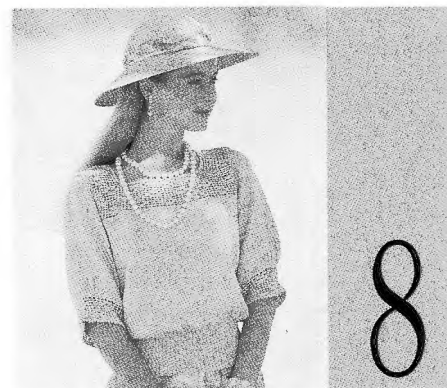

**MACHINES:** A, C or D with KR. **MATERIALS:** TWILLEYS Galaxia '5'; M - 350 (365, 380, 395, 410)g (Pale Green 60) (100% Acrylic 494m/100g). **MEASUREMENTS:** To fit bust 86 (91, 96, 101, 106)cm. **TENSION:** St St - 40 sts = 11.7cm and 60 rows = 12.7cm (approx T5). **RIB:** 2 x 1 (see ABBREVIATIONS) T2/2.

### Sleeve head shaping

At beg of next and every row cast off 3 sts x 48. Cast off rem 40 sts. **CUFFS:** Push 95 KH Ns into WP. With wrong side facing, place sts from cuff edge back onto Ns distributing extra sts across centre Ns. Trans to RIB, 000. Knit to RC29. T10/8 knit 1 row. Trans all sts to KH and latch cast off each st individually.

### MAKE-UP

Join side and SLEEVE seams. Work CROCHET inset. Set in SLEEVES. Work 3 crochet buttonholes at back opening and attach buttons.

### CROCHET - Front Yoke

Using 2mm Hook work 145 (151, 151, 157, 163)dc evenly across FRONT, 3 c, turn. Work one row tr, 3c, turn. Work from Chart as follows: **1st row:** 1 tr into each of next 3 tr, 2 c. \*1 tr into 3rd tr, 2 c\*, repeat from \* to \* to last 4 tr, 1 tr into each tr to end, 3 c, turn. **2nd row:** 1 tr into each of next 3 tr. Work 6 (7, 7, 8, 9) 2csp, \*[2 tr into next 2csp, 1 tr into next tr] twice, 6 2csp\*, repeat from \* to \* ending 6 (7, 7, 8, 9) 2csp, 1 tr into each of last 3 tr, 3c, turn. This sets the position of the Chart, cont from Chart until complete.

### BACK

Using WY cast on over 164 (172, 180, 188, 196) KH Ns and knit a few rows ending with COR, 000. Using M T5 knit to RC94.

### Armhole shaping

At beg of next and every row cast off 4 sts x 2, 3 sts x 4, 2 sts x 6, then dec 1 st at each end of alt rows x 5 (7, 9, 11, 13). \* Knit to RC170 and cast off rem 122 (126, 130, 134, 138) sts. **WAIST RIBS:** Push 131 (140, 149, 158, 167) KH Ns into WP. With wrong side facing, place sts from waist edge back onto Ns distributing them evenly along the row. Trans to RIB, 000. Knit to RC49. T10/8 knit 1 row.

### Back Yoke

As FRONT, work first 13 rows of Chart only.

### CUFFS

Work 121 (127, 127, 133, 139) dc evenly around sleeve edge, 3 c, turn. Work 1 row tr, 5 c, turn. Work from Chart as follows: **1st row:** \*1 tr into 3rd tr, 2 c\*, repeat from \* to \* ending 5 c, turn. **2nd row:** Work 5 (6, 6, 7, 8) 2csp, \*[2 tr into next 2csp, 1 tr into next tr] twice, 6 2csp\*, repeat from \* to \* ending 1 (2, 2, 3, 4) 2csp, 5 c, turn. This sets the position of the Chart, cont from Chart until complete. **PICOT EDGING:** See Patt No. 6

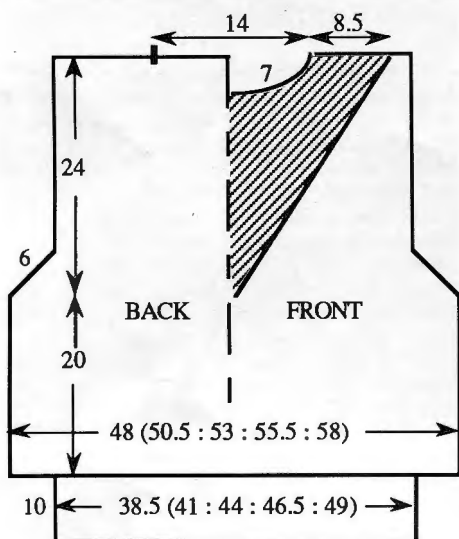

With wrong side facing place sts from waist edge back onto Ns distributing them evenly along the row. Trans to RIB, 000. Knit to RC49. T10/8 knit 1 row. Trans all sts to KH and latch cast off each st individually.

### FRONT

As BACK to RC94, COR.

### Armhole and V-neck shaping

Waste knit all sts at left of '0'. Shape armhole as BACK, and, AT THE SAME TIME, at neck edge dec 1 st on alt rows x 52. Knit to RC208 and cast off rem 9 (11, 13, 15, 17) sts. Return sts at left to Ns and knit to match right side reversing shapings.

### SLEEVES

Using WY cast on over 156 KH Ns and knit a few rows ending with COR, 000. Using M T5 knit to RC4. Inc 1 st at each end of next and every foll 4th row x 14. Knit to RC66.

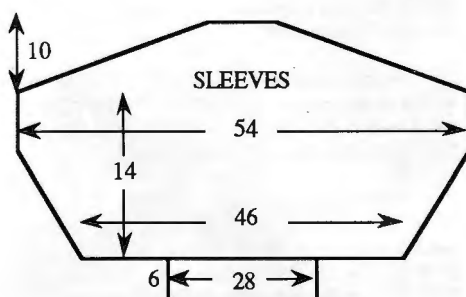

### CUFF

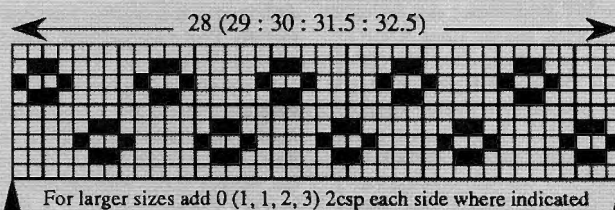

### FRONT YOKE

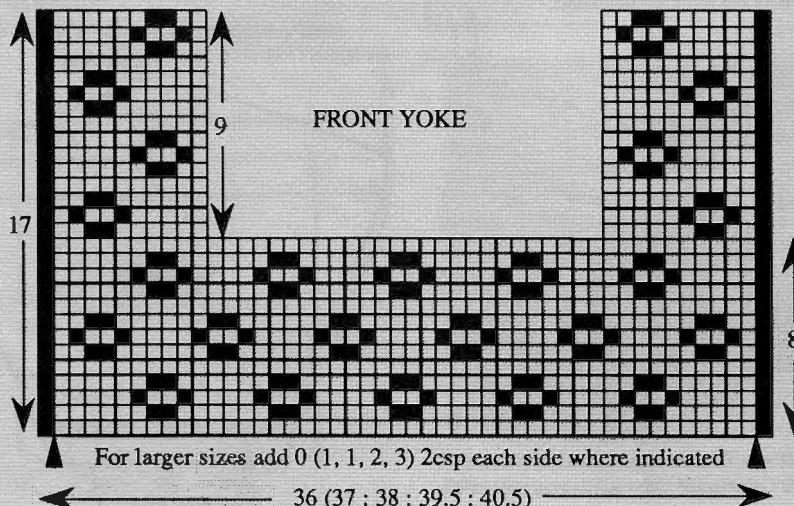



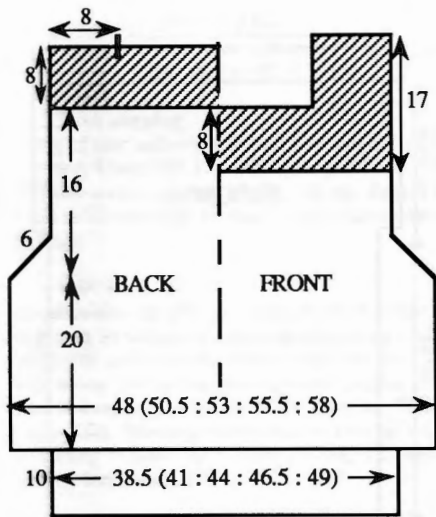

Trans all sts to KH and latch cast off each st individually.

#### FRONT

As BACK to \*. Knit to RC132 and cast off rem 122 (126, 130, 134, 138) sts.

#### SLEEVES

Using M COBH over 156 KH Ns. 000. Knit to RC4. Inc 1 st at each end of next and every foll 4th row x 14. Knit to RC66.

#### Sleeve head shaping

At beg of next and every row cast off 3 sts x 48. Cast off rem 40 sts.

#### MAKE-UP

Join shoulder seams. Set in SLEEVES. Join side and SLEEVE seams. Picot edging: See Patt No. 6.

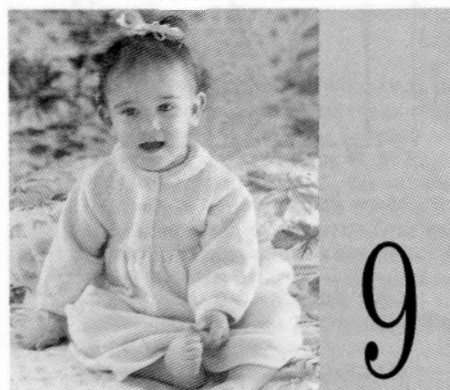
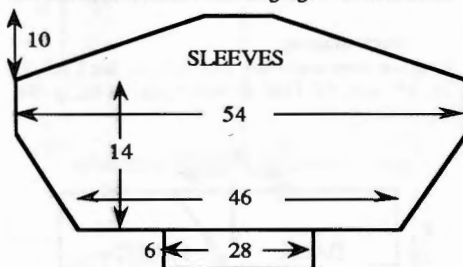

**MACHINES:** A, C or D with Garter Carriage. **MATERIALS:** SUNBEAM Baby 4-Ply; M - 340 (360, 380)g (Peach 224) (80% Acrylic, 20% Nylon 398m/100g). 5 buttons. Lace collar and lace frill for hem. **MEASUREMENTS:** To fit chest 45 (48, 53)cm [approx age 0 - 6 (6 - 12, 12 - 18) months]. **TENSION:** Garter Carr St Patt A - 40 sts = 14cm and 60 rows = 13cm (approx T7), Garter Carriage St Patt B (1 row knit, 1 row purl) - 40 sts = 14.8cm and 60 rows = 10cm (approx T6). **NOTES:** See Pattern sheet No 7(C) for Garter Carr St Patt A.

#### DRESS BACK - SKIRT

\* Using M COBH over 126 (134, 146) KH Ns. 000. T6 working in St Patt B, knit to RC12. T7 working

in St Patt A throughout, knit to RC112 (128, 144) and waste knit\*.

#### Bodice

Using WY and K-Carr cast on over 63 (67, 73) KH Ns and knit a few rows. Using M T6 knit 1 row, 000. Working in St Patt B knit to RC54 (66, 78). Waste knit centre 21 (25, 27) sts. Waste knit rem 21 (21, 23) sts at each end for shoulders. With right side facing, place sts from waist edge of BODICE back onto Ns. With wrong side facing, place sts from waist edge of SKIRT back onto Ns distributing them evenly along the row. Using K-Carr T10 knit 1 row and cast off.

#### FRONT

As BACK from \* to \*.

#### Right Front Bodice

Using WY cast on over 35 (37, 41) KH Ns and knit a few rows ending with COL. Using M T6 knit 1 row, 000. Working in St Patt B knit to RC6 (10, 14). At left on next and every foll 13th (17th, 21st) row make a 1 st buttonhole, by trans the 5th st onto the 4th N, x 3. Knit to RC37 (49, 61).

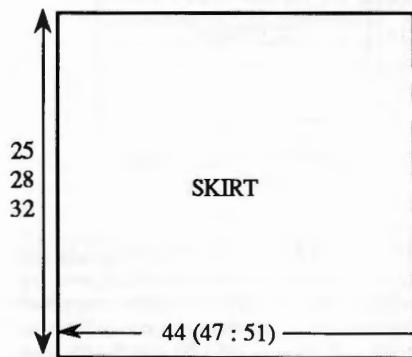
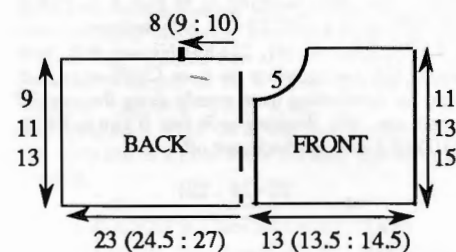

#### Neck shaping

COL, at beg of next and every foll alt row cast off 6 sts x 1, 2 sts x 2 (3, 4) then dec 1 st every 4th row x 4. Knit to RC66 (78, 90) and waste knit rem 21 (21, 23) sts.

#### Left Front Bodice

As Right Front Bodice reversing shapings and omitting buttonholes.

#### NECKBAND

Join shoulders by placing both sets of shoulder sts back onto Ns with right sides together, using M T10 knit 1 row and cast off. Push 57 (63, 67) KH Ns into WP. With right side facing, pick up same number of sts evenly along neck edge and place onto Ns, 000. T6 knit to RC8 and waste knit.

#### SLEEVES

Join Front Bodice to Front Skirt as BACK, overlap-

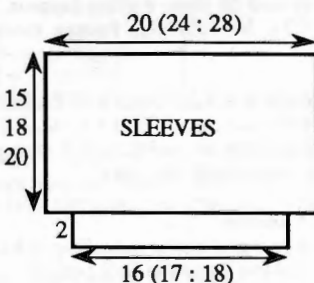

ping Right Front over Left. Push 57 (68, 80) KH Ns into WP. With wrong side facing pick up same number of sts evenly along armhole edge of Bodice and place onto Ns, T7 knit 1 row, 000. Working in St Patt A (UPSIDE DOWN) knit to RC70 (82, 92) and waste knit. **CUFFS:** Push 46 (49, 52) KH Ns into WP. With wrong side facing, place sts from CUFF edge onto Ns distributing them evenly along the row. T6 knit 1 row, 000. Working in St Patt B, knit to RC11, T10 knit 1 row and latch cast off.

#### MAKE-UP

Join side and SLEEVE seams. Gather neck edge of Collar to fit neck edge of garment. Fold NECK-BAND in half to outside and backstitch to garment through last row knitted in M encasing Collar. Attach buttons and lace.

#### CARDIGAN - BACK

\*\* Using M COBH over 73 (77, 83) KH Ns, 000. T6 working in St Patt B knit to RC12. T7 working in St Patt A knit to RC90 (100, 108)\*\*. Place a WY marker at each end of work. Knit to RC132 (150, 168). Waste knit centre 35 sts. Waste knit rem 19 (21, 24) sts at each end for shoulders.

#### RIGHT FRONT

Repeat from \*\* to \*\* over 33 (36, 39) KH Ns. Place a WY marker at right end of work. Knit to RC113 (133, 151).

#### Neck shaping

COL, At beg of next and every foll alt row cast off 4 (5, 5) sts x 1, 2 sts x 2, then dec 1 st x 6. Knit to RC140 (160, 178) and waste knit rem 19 (21, 24) sts.

#### LEFT FRONT

As RIGHT FRONT reversing shapings.

#### NECKBAND

Join shoulders by placing both sets of shoulder sts back onto Ns with right sides together, using M T10 knit 1 row and cast off. Push 81 KH Ns into WP. With wrong side facing, pick up same number of sts evenly along neck edge and place onto Ns. T6 knit 1 row, 000. Working in St Patt B knit to RC12 decreasing the Tension by ° every 2 rows. T10 knit 1 row and latch cast off.

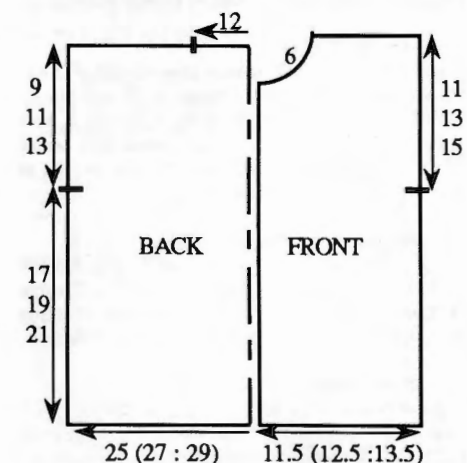

#### SLEEVES

As DRESS SLEEVES.

#### BUTTONHOLE BAND

Push 70 (81, 92) KH Ns into WP. With wrong side facing, pick up same number of sts evenly along RIGHT FRONT opening edge and place onto Ns, T6 knit 1 row, 000. T5 working in St Patt B. Knit to RC6. Work 2 x 1 st buttonholes over the 4th and 17th Ns at right end. Knit to RC12. T10 knit 1 row and latch cast off.

#### BUTTON BAND

As BUTTONHOLE BAND omitting buttonholes.



## MAKE-UP

Join side and SLEEVE seams. Attach buttons.

## ROMPER SUIT

**MACHINES:** A, C or D with Garter Carriage.  
**MATERIALS:** SUNBEAM Baby 4-Ply; M - 160 (180, 200)g (Peach 224) (80% Acrylic, 20% Nylon 398m/100g). 3 buttons. Lace Collar. **MEASUREMENTS:** To fit chest 45 (48, 53)cm [approx age 0 - 6 (6 - 12, 12 - 18) months]. **TENSION:** Garter Carr St Patt A - 40 sts = 14cm and 60 rows = 13cm (approx T7), Garter Carr St Patt B (1 row knit, 1 row purl) - 40 sts = 14.8cm and 60 rows = 10cm (approx T6). **NOTES:** See Pattern sheet No 7(C).

## LEGS

Using K-Carr and WY cast on over 68 (74, 82) KH Ns and knit a few rows ending with COL. Change to M and Garter Carr T6 knit 1 row, 000. Working in St Patt B, knit to RC84 (96, 102).

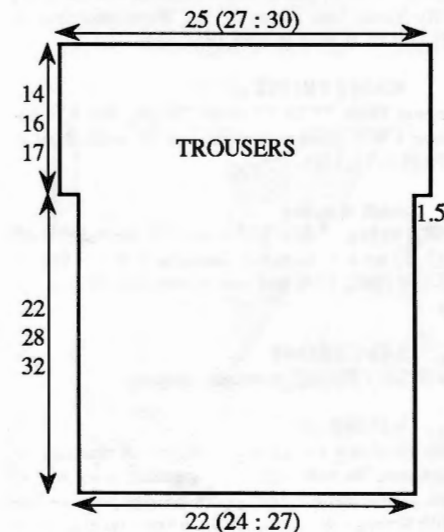

## Crotch shaping

At beg of next 2 rows cast off 4 sts. Knit to RC216 (264, 294). T10 knit 1 row and latch cast off. Join Front and Back seams to start of Crotch shaping.

## BACK BODICE

Using K-Carr and WY cast on over 65 (69, 77) KH Ns and knit a few rows. Change to M and Garter Carr T7 knit 1 row, 000. Working in St Patt A, knit to RC42 (50, 60). Using K-Carr, waste knit centre 23 (27, 29) sts. Waste knit rem 21 (21, 24) sts at each end of work for shoulders.

## RIGHT FRONT BODICE

Using K-Carr and WY cast on over 30 (33, 36) KH Ns and knit a few rows ending with COL. Change to M and Garter Carr T7 knit 1 row, 000. Working in St Patt A throughout, knit to RC27 (37, 47).

## Neck shaping

COL, at beg of next and every foll alt row cast off 3 sts x 1 (2, 2), 2 sts x 1, then dec 1 st x 4. Knit to RC50 (60, 70) and waste knit rem 21 (21, 24) sts.

## LEFT FRONT BODICE

As RIGHT FRONT BODICE reversing shapings.

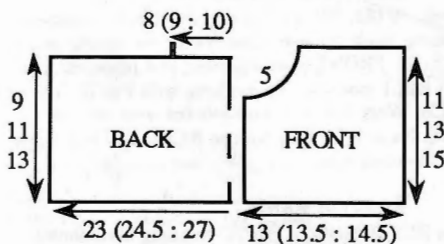

## BUTTONHOLE BAND

Push 22 (28, 30) KH Ns into WP. With wrong side facing, pick up same number of sts evenly along RIGHT FRONT opening edge and place onto Ns, T6 knit 1 row, 000. T5 working in St Patt B knit to RC6. Make 3 x 1 st buttonholes evenly spaced along the row. Knit to RC12. T10 knit 1 row and latch cast off.

## BUTTON BAND

As BUTTONHOLE BAND omitting buttonholes.

## NECKBAND

Join shoulders by placing both sets of shoulder sts back onto Ns with right sides together. Using K-Carr T10 knit 1 row and cast off. Push 57 (63, 67) KH Ns into WP. With right side facing, pick up same number of sts evenly along neck edge and place onto Ns, 000. Using M and St Patt B, T6 knit to RC8 and waste knit.

## SLEEVES

Push 57 (68, 80) KH Ns into WP. With wrong side facing pick up same number of sts evenly along armhole edge and place onto Ns, using K-Carr T7 knit 1 row, 000. Working in St Patt A (UPSIDE DOWN) knit to RC70 (82, 92) and waste knit. **CUFFS:** Push 46 (49, 52) KH Ns into WP. With wrong side facing, place sts from CUFF edge back onto Ns distributing them evenly along the row. T7 knit 1 row, 000. Working in St Patt B knit to RC11, T10 knit 1 row and latch cast off.

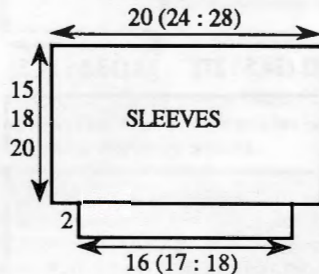

## MAKE-UP

Push 64 (68, 76) KH Ns into WP. With right side facing, place sts from BACK BODICE onto Ns. With wrong side facing, and placing the centre back seam of the legs in the centre, place half the sts from waist edge of legs onto Ns distributing them evenly along the row. Using K-Carr and M T10 knit 1 row and cast off. Repeat for FRONT BODICE overlapping BUTTONHOLE/BUTTON BANDS at centre. Join inside leg seams. Join SLEEVE seams. Gather neck edge of Collar to fit neck edge of garment. Fold NECKBAND in half to outside and backstitch to garment through last row knitted in M encasing Collar. Attach buttons.

## LEGGINGS, VEST AND SWEATER

**MACHINES:** A, C or D with Garter Carriage.  
**MATERIALS:** SUNBEAM Baby 4-Ply; M - 260 (280, 300)g (Peach 224) (80% Acrylic, 20% Nylon 398m/100g). 3 buttons. Elastic to fit waist + 2.5cm. Ribbon. Snap fasteners. **MEASUREMENTS:** To fit chest 45 (48, 53)cm [approx age 0 - 6 (6 - 12, 12 - 18) months]. **TENSION:** Garter Carr St Patt A - 40 sts = 14cm and 60 rows = 13cm (approx T7), Garter Carr St Patt B (one row knit, 1 row purl) - 40 sts = 14.8cm and 60 rows = 10cm (approx T6). **RIB:** 1 x 1 T4. **NOTES:** See Pattern sheet No 7(C).

## LEGGINGS RIGHT AND LEFT LEGS

Using M COBH over 68 (74, 82) KH Ns, 000. T4 working in 1 x 1 RIB knit to RC20, 000. Change to St Patt B T6 knit to RC84 (96, 102).

## Crotch shaping

Cast off 4 sts at beg of next 2 rows. Knit to RC216 (264, 294). T10 knit 1 row and latch cast off.

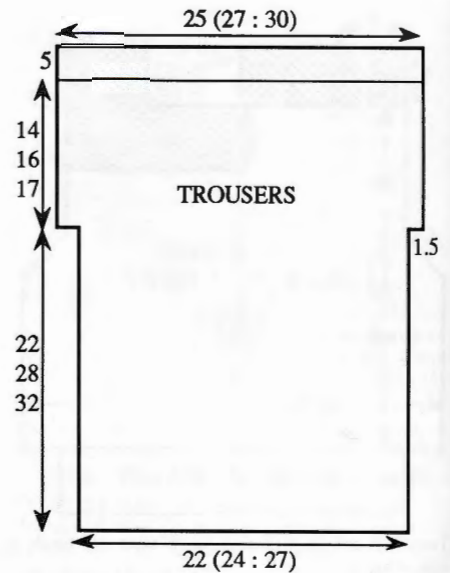

## MAKE-UP

Join Front and Back seams to Crotch shaping. Join inside LEG seams. Fold Waistband in half to inside and catch down loosely encasing elastic.

## VEST - BACK

Using M COBH over 59 (65, 71) KH Ns, 000. T6 working in St Patt B, knit to RC78 (84, 90).

## Sleeve shaping

Cast on 5 sts at beg of next 2 rows. Knit to RC120 (132, 144). Waste knit 25 (27, 29) sts at each end of work for shoulders. Cast off rem 19 (21, 23) sts.

## RIGHT FRONT

Using M COBH over 41 (43, 47) KH Ns, 000. T6 working in St Patt B knit to RC56 (68, 72).

## Neck shaping

At left on next and every foll 3rd row dec 1 st x 21 (21, 23) and, AT THE SAME TIME, at RC78 (84, 90), COR.

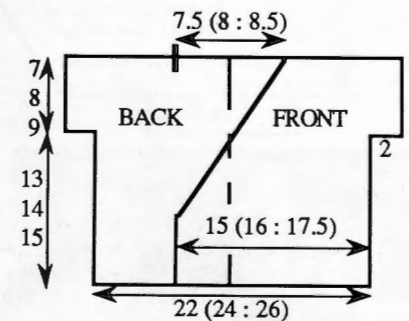

## Sleeve shaping

Cast on 5 sts at beg of next row. Knit to RC120 (132, 144) and waste knit rem 25 (27, 29) sts.

## LEFT FRONT

As RIGHT FRONT reversing shapings.

## MAKE-UP

Join shoulders by placing both sets of shoulder sts back onto Ns with right sides together. Using M and K-Carr T10 knit 1 row and cast off. Join side and SLEEVE seams. Attach ribbons as illustrated. Attach fasteners.

## SWEATER BACK

\* Using M COBH over 73 (77, 83) KH Ns, 000. T6 working in St Patt B knit to RC12. T7 working in St Patt A knit to RC90 (100, 108). Place a WY marker at each end of work \*. Knit to RC132 (150, 168). Waste knit centre 35 sts. Waste knit rem 19 (21, 24) sts at each end for shoulders.

## FRONT

As BACK from \* to \*.



### Front opening

(Note patt position). Cast off centre 7 sts. Waste knit sts at left, COR. Knit to RC113 (133, 157).

### Neck shaping

At beg of next and every foll alt row cast off 3 sts x 1, 2 sts x 3 then dec 1 st x 5. Knit to RC140 (160, 178) and waste knit rem 19 (21, 24) sts. Return sts at left to Ns and knit to match right side reversing shapings.

### NECKBAND

Join shoulders by placing both sets of shoulder sts back onto Ns with right sides together, using M T10 knit 1 row and cast off. Push 81 KH Ns into WP. With wrong side facing, pick up same number of sts evenly along neck edge and place onto Ns. T6 knit 1 row, 000. Working in St Patt B knit to RC12 decreasing Tension by ° every 2 rows. T10 knit 1 row and latch cast off.

### BUTTONHOLE BAND

Push 25 (31, 33) KH Ns into WP. With wrong side facing, pick up same number of sts evenly along RIGHT FRONT opening edge and place onto Ns, using M T6 knit 1 row, 000. T5 working in St Patt B knit to RC6. Make 3 x 1 st buttonholes evenly spaced along the row. Knit to RC12. T10 knit 1 row and latch cast off.

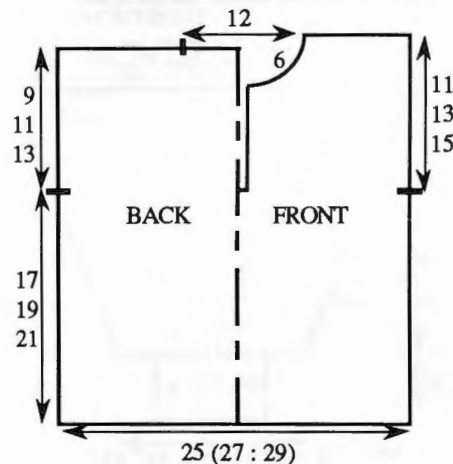

### BUTTON BAND

As BUTTONHOLE BAND omitting buttonholes.

### SLEEVES

Push 57 (68, 80) KH Ns into WP. With wrong side facing pick up same number of sts evenly along armhole edge between WY markers and place onto Ns, T7 knit 1 row, 000. Working in St Patt A (UPSIDE DOWN) knit to RC70 (82, 92) and waste knit. CUFFS: Push 46 (49, 52) KH Ns into WP. With wrong side facing, place sts from cuff edge back onto Ns distributing them evenly along the row. T7 knit 1 row, 000. Working in St Patt B knit to RC11, T10 knit 1 row and latch cast off.

### MAKE-UP

Join side and SLEEVE seams. Attach BANDS to cast off edge of FRONT. Attach buttons.

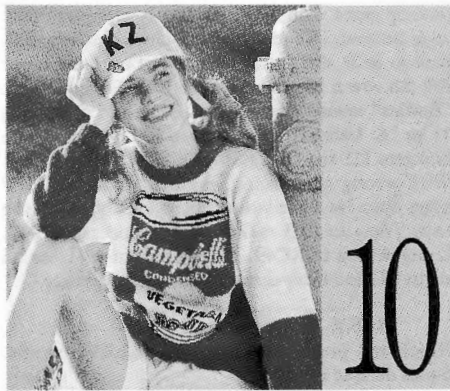
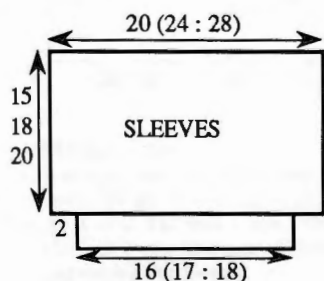

**MACHINES:** A, C or D with KR, KL and Intarsia Carriage or Intarsia facility. **MATERIALS:** KING COLE Anti-Tickle Superspun Superwash 4-Ply Wool; M - 250 (275, 300, 325, 350)g (Scarlet 9), A - 210 (230, 250, 270, 290)g (White 1), B - 25g (Black 48), small amount of C - (Gold 55). (100% Wool 380m/100g). **MEASUREMENTS:** To fit chest 70 (75, 81, 86, 91)cm. **TENSION:** St st/Intarsia (when making your tension swatch use Intarsia Carr if you intend to work the garment with Intarsia Carr - Intarsia Carr and K-Carr tensions can be very different) 40 sts = 12cm and 60 rows = 13.8cm (approx T6). **RIB:** 2 x 1 (see Abbreviations) T2/2. **NOTES:** See Pattern Sheet No 7(D) and 8(A) for swiss darning and 9(A) for Intarsia.

### PROCEDURE (see STEP-BY-STEP)

Make a tension swatch and set KL accordingly. Draw design and FRONT diagram onto KL sheet as desired. It is possible to use the KL sheet to indicate the picture and follow the garment instructions simultaneously.

### BACK

Using M cast on over 140 (149, 158, 167, 176) KH Ns as RIB, 000. Knit to RC36. Trans all sts to KH. Inc 2 (1, 2, 1, 0)sts, 000. T6 working in st st throughout, knit to RC92 (110, 118, 136, 144). Change to A and knit to RC122 (130, 130, 140, 140). Place a WY marker at each end of work. Knit to RC200 (218, 226, 244, 254). Waste knit centre 50 sts. Waste knit rem 46 (50, 55, 59, 63) sts at each side of work for shoulders.

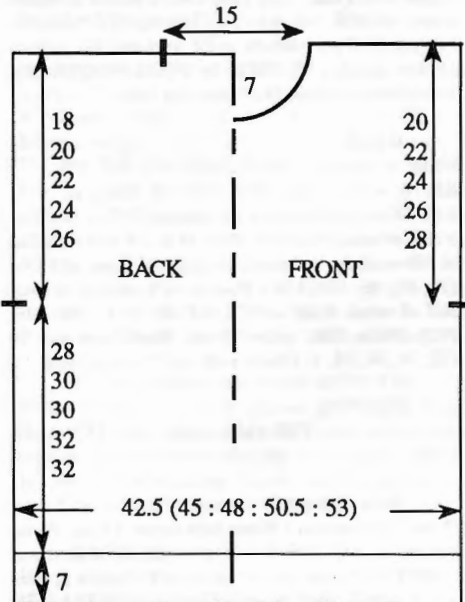

### FRONT

As BACK to RC14 (32, 40, 58, 66). Beg Intarsia design and, AT THE SAME TIME, (as BACK), knit to RC180 (196, 204, 224, 232), COR.

### Neck shaping

Waste knit centre 20 sts. Waste knit sts at left. COR.

Knit 1 row. At beg of next and every foll alt row cast off 4 sts x 1, 3 sts x 1, 2 sts x 2, then dec 1 st x 4. Knit to RC210 (226, 234, 254, 262) and waste knit rem 46 (50, 55, 59, 63) sts. Return sts at left to Ns and knit to match right side reversing shapings.

### NECKBAND

Join one shoulder by placing one set of shoulder sts back onto Ns with right sides together. Using A T10 knit 1 row and cast off. Push 122 KH Ns into WP. With right side facing, pick up same number of sts evenly along neck edge and place onto Ns. Using M T6 knit 1 row. Trans to RIB making sts as necessary, 000. Knit to RC26. Trans all sts to KH. T6 knit 2 rows and waste knit. Join second shoulder as first. Join NECKBAND seam, fold in half to outside and backstitch to garment through last row knitted in M.

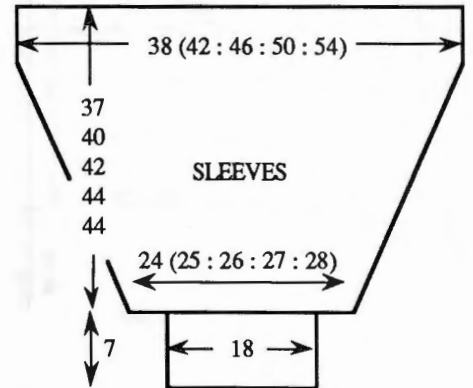

### SLEEVES

Push 127 (140, 153, 167, 180) KH Ns into WP. With wrong side facing, pick up same number of sts evenly along armhole edge between WY markers and place onto Ns, 000. Using A, T6 knit to RC16 (6, 17, 36, 20). Dec 1 st at each end of next and every foll 6th (6th, 5th, 4th, 4th) row x 24 (28, 33, 39, 43) and, AT THE SAME TIME at RC80 (87, 91, 96, 96) change to M and knit to RC160 (174, 182, 192, 192). Waste knit rem 79 (84, 87, 89, 94) sts. CUFFS: Push 62 KH Ns into WP. With wrong side facing, place sts from cuff edge onto Ns distributing them evenly along the row. Trans to RIB, 000. Using M knit to RC35. T10/8 knit 1 row. Trans all sts to KH and latch cast off each st individually.

### MAKE-UP

Block and press. Join side and SLEEVE seams. Swiss darn text on Soup Can as illustrated.

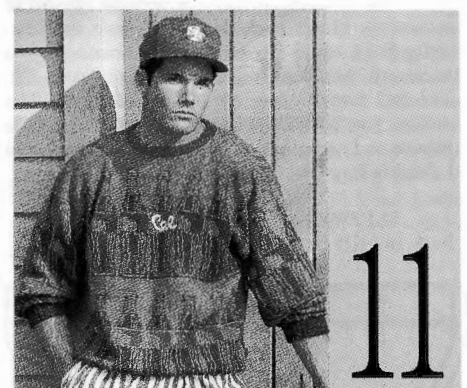

**MACHINES:** A, C or D with KR. **MATERIALS:** KING COLE Anti-Tickle Superspun Superwash 4-Ply Wool; M - 315 (335, 355, 375, 395)g (Green Ice 63), A - 315 (330, 345, 360, 375)g (Chocolate 23), B - 45 (50, 55, 60, 65)g (Scarlet 9). (100% wool 380m/100g) **MEASUREMENTS:** To fit chest 86 (91, 96, 101, 106, 111)cm. **TENSION:** Fairisle St Patt - 40 sts = 12.7cm and 60 rows = 13.9cm (approx T6). **RIB:** 2 x 1 (see Abbreviations) T2/2. **NOTES:** See Stitch Pattern Sheet No 3(A).



## BACK

Using A cast on over 158 (167, 173, 182, 191, 197) KH Ns as RIB, 000. Knit to RC40. Trans all sts to KH. Inc 1 (0, 2, 1, 0, 2) sts, 000. Place a WY marker at each end of work at RC172 and AT THE SAME TIME work "Bottles" as folls: \*\*\*. \* Using M T6 knit 1 row. Set for first patt row and knit 1 row to select Ns. With M in FA and A in FB knit 42 rows. \*\* With M in FA and B in FB knit 18 rows. \*\* With M in FA and A in FB knit 36 rows. With M in FA and B in FB knit 3 rows. \* Repeat from \* to \* working section from \*\* to \*\* using B instead of A. \*\*\* Using M only and working in st st knit to RC296. Waste knit centre 63 sts. Waste knit rem 48 (52, 56, 60, 64, 68) sts at each end of work for shoulders.

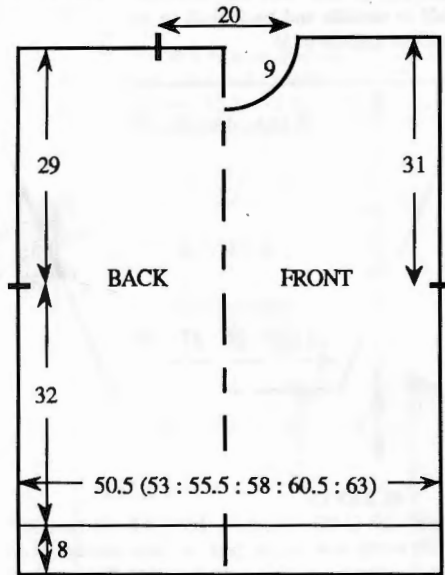

## FRONT

As BACK to RC270, COR.

### Neck shaping

Waste knit centre 23 sts. Waste knit sts at left, COR. Knit 1 row. At beg of next and every foll alt row cast off 4 sts x 1, 3 sts x 2, 2 sts x 2, then dec 1 st x 6. Knit to RC305 and waste knit rem 48 (52, 56, 60, 64, 68) sts. Return sts at left to Ns and knit to match right side reversing shapings.

### NECKBAND

Join one shoulder by placing one set of shoulder sts back onto Ns with right sides together. Using M T10 knit 1 row and cast off. Push 149 KH Ns into WP. With right side facing, pick up same number of sts evenly along neck edge and place onto Ns. Using B T6 knit 1 row. Trans to RIB making sts as necessary, 000. Knit to RC24. Trans all sts to KH. T6 knit 2 rows and waste knit. Join second shoulder as first. Join NECKBAND seam and fold in half to outside and backstitch to garment through last row knitted in B.

### SLEEVES

Push 189 KH Ns into WP. With wrong side facing,

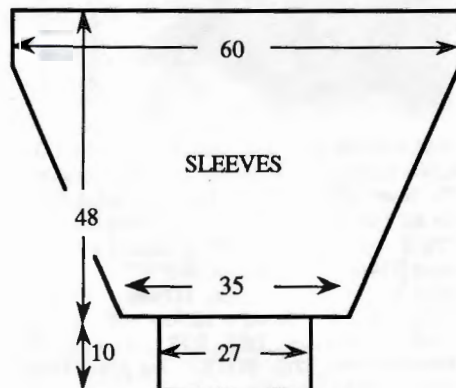

pick up same number of sts evenly along armhole edge between WY markers and place onto Ns, 000. Knit to RC9, dec 1 st at each end of next and every foll 5th row x 39, and AT THE SAME TIME work "Bottles" upside down as for Back except reading 11 as 6. Using M only knit to RC204 and waste knit rem 111 sts. CUFFS: Push 86 KH Ns into WP. With wrong side facing, replace sts from CUFF edge onto Ns distributing them evenly along the row. Trans to RIB making sts as necessary, 000. Using A knit to RC49. T10/8 knit 1 row. Trans all sts to KH and latch cast off each st individually.

### MAKE-UP

Block and press. Join side and SLEEVE seams. Swiss darn as illustrated.

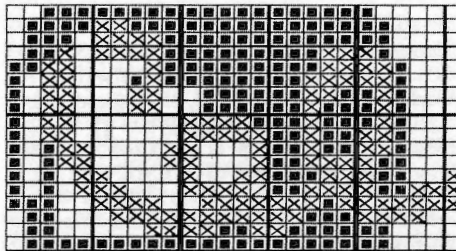

**MACHINES:** C or D with KR. **MATERIALS:** ATKINSON YARNS DESIGNER COLLECTION Wharfedale; M - 100 (115, 130, 145, 160, 175)g (Silver 11049), Con Col - 70 (80, 90, 100, 110, 120)g (Black 11089). (45% acrylic 30% nylon 25% wool 47.5m/100g). **MEASUREMENTS:** To fit height 116 (122, 128, 134, 140, 146)cm [Approx chest 61 (63, 66, 69, 71, 74)cm]. **TENSION:** Fairisle St Patt - 40 sts = 14.5cm and 60 rows = 15.7cm (approx T8). **RIB:** 1x 1 T2/2. **NOTES:** See Stitch Pattern Sheet No 7(A).

## BACK

Using M cast on over 97 (103, 107, 111, 115, 121) KH Ns as RIB, 000. Knit to RC25. Trans all sts to KH. T8 set for first row of Fairisle St Patt and knit 1 row to select Ns, 000. With M in FA and Con Col in FB working in fairisle throughout, knit to RC64 (72, 80, 96, 106, 114). Place a WY marker at each end of work. Knit to RC114 (126, 138, 158, 170, 182). Waste knit centre 39 sts. Waste knit rem 29 (32, 34, 36, 38, 41) sts at each end for shoulders.

## FRONT

As BACK to RC96 (108, 118, 138, 152, 164), COR.

### Neck shaping

(Note patt position.) Waste knit centre 15 sts. Waste knit sts at left, COR. Knit 1 row. At beg of next and every foll alt row cast off 3 sts x 1, 2 sts x 2, then dec 1 st x 5. Knit to RC122 (134, 144, 164, 178, 190) and waste knit rem 29 (32, 34, 36, 38, 41) sts. Return sts at left to Ns and knit to match right side reversing shapings.

### NECKBAND

Join one shoulder by placing one set of shoulder sts back onto Ns with right sides together. Using M

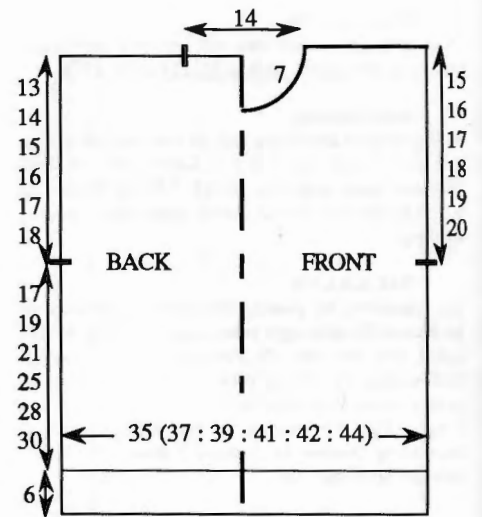

T10 knit 1 row and cast off. Push 107 KH Ns into WP. With right side facing, pick up same number of sts evenly along neck edge and place onto Ns. Using M T7 knit 1 row. Trans to RIB, 000. Knit to RC20. Trans all sts to KH. T7 knit 2 rows and waste knit. Join second shoulder as first. Join NECKBAND seam, fold in half to outside and backstitch to garment through last row knitted in M.

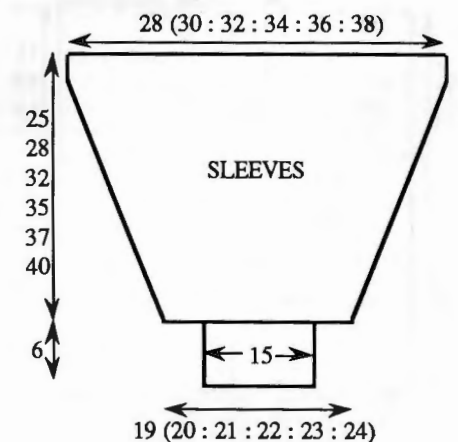

### SLEEVES

Push 77 (81, 87, 91, 97, 103) KH Ns into WP. With wrong side facing, pick up same number of sts evenly along armhole edge between WY markers and place onto Ns. Set to knit st patt upside down. T8 using M knit 1 row to select Ns, 000. With M in FA and Con Col in FB working in fairisle throughout, knit to RC4 (10, 10, 14, 4, 8). Dec 1 st at each end of next and every foll 8th row x 12 (12, 14, 15, 17, 18). Knit to RC96 (106, 122, 134, 140, 152) and waste knit rem 53 (57, 59, 61, 63, 67) sts. CUFFS: Push 47 KH Ns into WP. With wrong side facing place sts from CUFF edge onto Ns distributing them evenly along the row. Using M T7 knit 1 row. Trans to RIB, 000 knit to RC25. T10/8 knit 1 row. Trans all sts to KH and latch cast off.

### MAKE-UP

Block and press. Join side and SLEEVE seams.



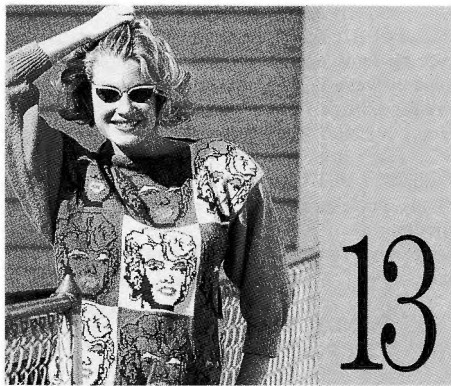

**MACHINES:** C or D with KR. **MATERIALS:** PAMELA WISE 4 Fold Cotton Quality 8046; M - 190 (210, 230, 250, 270)g (Dark Blue 68), A - (Green 80), B - (Mid Blue 43), C - (Yellow 25) - 100 (115, 130, 145, 160)g of each, D - 125g (Cerise 51), E - 100g (Turquoise 22). (100% cotton 300m/100g). **MEASUREMENTS:** To fit bust 86 (91, 96, 101, 106)cm. **TENSION:** Fairisle - 40 sts = 15cm and 60 rows = 16.8cm (approx T9). St St - 40 sts = 13.8cm and 60 rows = 19cm (approx T9). **RIB:** 1 x 1 T3/3. **NOTES:** See Stitch Pattern Sheet No 6(E).

#### BACK/FRONT

Using WY cast on over 52 (54, 56, 58, 60) KH Ns and knit a few rows ending with COR. \* 000 T9 using A knit 1 row. Set Change Knob to KCII. Set for first patt row and knit 1 row to select Ns. With A in FA and M in FB working in single motif method throughout, knit to RC73. Using A knit 2 rows \*. Repeat from \* to \* reading A as B, then repeat from \* to \* reading A as C. Waste knit. Knit 2 more 'panels' changing order of colours as illustrated, and AT THE SAME TIME, at RC43 of second motif place a WY marker at outside edge. Swiss darn 'Lips' and 'Eyes' as illustrated. Using mattress stitch join 'panels'. Block and press. **WAIST RIBS:** Push 133 (139, 145, 151, 157) KH Ns into WP. With wrong side facing, place sts from waist edge onto Ns distributing them evenly along the row. Using M \*\* T9 knit 1 row. Trans to RIB, 000. Knit to RC29. T10/8 knit 1 row. Trans all sts to KH and latch cast off\*\*.

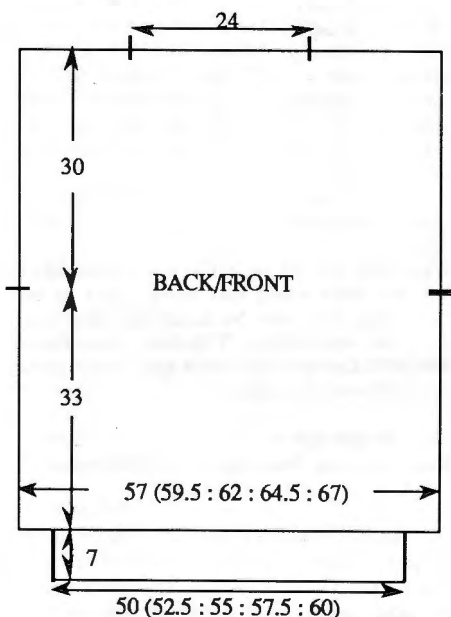

#### NECK FACING

Push 64 KH Ns into WP. With wrong side facing, place centre 64 sts of neck edge onto Ns. Using either A, B or C T10 knit 1 row. 000. T7 knit to RC9. T10 knit 1 row and cast off loosely. Fold to inside and catch down loosely.

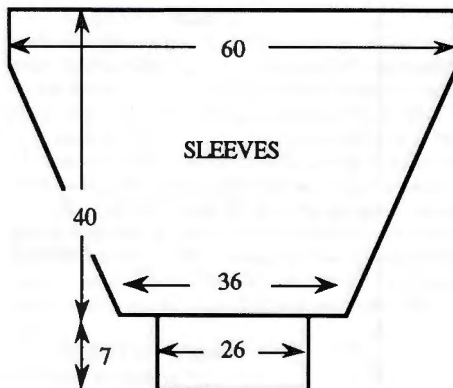

#### SLEEVES

Join shoulders by placing both sets of shoulder sts back onto Ns with right sides together. T10 knit 1 row and cast off loosely. Push 174 KH Ns into WP. With wrong side facing, pick up same number of sts evenly along armhole edge between WY markers and place onto Ns, 000. Using D T9 knit to RC21. Dec 1 st at each end of next and every foll 3rd row x 35. Knit to RC126 and waste knit rem 104 sts. **CUFFS:** Push 75 KH Ns into WP. With wrong side facing, place sts from CUFF edge onto Ns distributing them evenly along the row. Using D repeat from \*\* to \*\*. Knit second SLEEVE using E.

#### MAKE-UP

Block and press SLEEVES. Join side and SLEEVE seams.



**MACHINES:** A, C or D with Intarsia facility or Intarsia Carriage and KL, with KR. **MATERIALS:** KING COLE Anti-Tickle Superspun Superwash 4-Ply Wool; M - 450 (470, 490, 510, 530)g (French Navy 25), small amounts in each of A - (Scarlet 9), B - (Linden 165), C - (Grape 163), D - (Royal 21), E - (Larkspur 13) (100% wool 380m/100g). 5 Buttons. **MEASUREMENTS:** To fit bust 86 (91, 96, 101, 106)cm. **TENSION:** St st/Intarsia (when making your tension swatch use Intarsia Carr if you intend to work the garment with Intarsia Carr - Intarsia Carr and K-Carr tensions can be very different) - 40 sts = 12cm and 60 rows = 13.8cm (approx T6). **RIB:** 2 x 1 (see Abbreviations) T2/2. See Stitch Pattern Sheet Nos 9(C), (D), (E) and (F).

#### PROCEDURE (see STEP-BY-STEP)

Make a tension swatch and set KL accordingly. Draw 'Shoes' design onto KL sheet as desired together with garment diagram. It is possible to use KL sheet to indicate the 'Shoes' and follow the garment instructions simultaneously.

#### BACK

Using M cast on over 167 (176, 182, 191, 200) KH Ns as RIB, 000. Knit to RC36. Trans all sts to KH. Inc 1 (0, 2, 1, 0) sts, 000. T6 knit to RC130. Place a WY marker at each end of work. Knit to RC252. Waste knit centre 60 sts. Waste knit rem 54 (58, 62, 66, 70) sts at each end of work for shoulders.

#### FRONT

As BACK to RC238, COR.

#### Neck shaping

Waste knit centre 30 sts. Waste knit sts at left, COR. \* Knit 1 row. At beg of next and every foll alt row cast off 3 sts x 3, 2 sts x 2 \*. Knit to RC262 and waste knit rem 54 (58, 62, 66, 70) sts. Return sts at left to Ns, COL. [RC238.] Repeat from \* to \*. Knit to RC252 and waste knit rem 54 (58, 62, 66, 70) sts.

#### NECKBAND

Join RIGHT shoulder by placing shoulder sts back onto Ns with right sides together. Using M T10 knit 1 row and cast off. Push 129 KH Ns into WP. With right side facing, pick up same number of sts evenly along neck edge and place onto Ns, \*\* 000. T5 knit to RC14. T10 knit 1 row. T5 knit to RC31 and waste knit. Fold in half to outside and backstitch to garment through last row knitted in M \*\*.

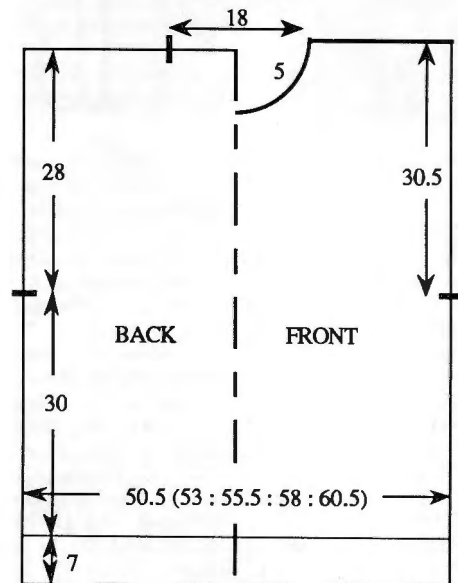

#### LEFT BACK SHOULDER PLACKET

Push 63 (67, 71, 75, 79) KH Ns into WP. With right side facing, pick up same number of sts evenly along Left Back Shoulder and NECKBAND and place onto Ns. Repeat from \*\* to \*\* as NECKBAND.

#### LEFT FRONT SHOULDER PLACKET

As LEFT BACK SHOULDER PLACKET making 5 x 3 st buttonholes evenly along rows 7 and 22.

#### RIGHT SLEEVE

Push 194 KH Ns into WP. With wrong side facing, pick up same number of sts evenly along armhole edge between WY markers and place onto Ns, 000. T6 knit to RC30. Dec 1 st at each end of next and every foll 4th row x 37. Knit to RC178 and waste knit rem 120 sts. **CUFFS:** Push 86 KH Ns into WP. With wrong side facing place sts from cuff edge onto Ns distributing them evenly along the row. Trans to RIB, 000. Knit to RC35. T10/8 knit 1 row. Trans all sts to KH and latch cast off each st individually.

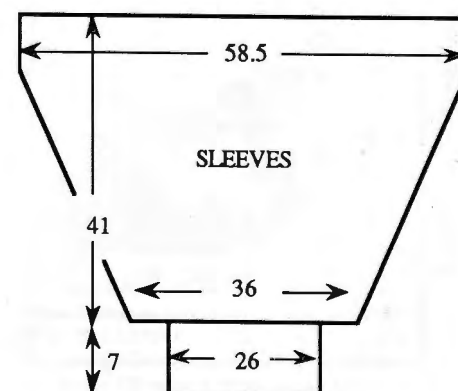



### LEFT SLEEVE

As RIGHT SLEEVE overlapping the SHOULDER PLACKETS as illustrated.

### MAKE-UP

Block and press. Join side and SLEEVE seams. Attach buttons.

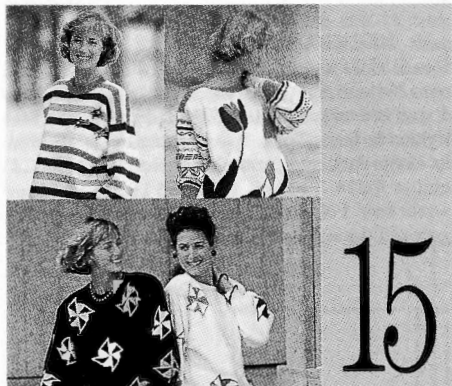

**MACHINES:** A and KR ("STRIPED" and "TULIPS"), C or D with KR, KL and Intarsia facility or Intarsia Carriage. **MATERIALS:** SPECTRUM Detroit DK; STRIPED: M - 175 (190, 205, 220, 235)g (White 101), A - 200 (210, 220, 230, 240)g (Raspberry 428), 40 - 50g in each of B - (Citron 441), C - (French Navy 440), D - (Waterfall 443), E - (Opal 411). "WINDMILL" M - 450 (475, 500, 525, 550)g (Black 111 or White 101), small amounts in each of A - (Raspberry 428), B - (Citron 441), C - (Waterfall 443), D - (Red 103), E - (Opal 411). "TULIPS": M - 350 (375, 400, 425, 450)g (White 101), small amounts in each of A, (Raspberry 428), B - Citron 441), C - (Bottle 112), D - (Red 103), E - (Koala 442), F - (Opal 411), G - (French Navy 440), H - (Primrose 200). (100% Acrylic. 270m/100g). **MEASUREMENTS:** To fit bust 86 (91, 96, 101, 106)cm. **TENSION:** St st/Intarsia (when making your tension swatch use Intarsia Carr if you intend to work the garment with the Intarsia Carr - Intarsia Carr and K-Carr tensions can be very different) - 40 sts = 15.7cm and 60 rows = 16.6cm (approx T10). Fairisle - 40 sts = 15.7cm and 60 rows = 17.4cm (approx T10). **RIB:** "STRIPED" and "WINDMILL" 1 x 1 T3/3, "TULIPS" 2 x 2 T4/4. **NOTES:** Except where otherwise stated instructions are given for all three garments. "STRIPED" - alternate 10 row stripes of M, with each of the other colours. "WINDMILL" see Pattern Sheet No 8(B) work Single Motifs at random as illustrated. "TULIPS" BACK is in st st only, for SLEEVES see Pattern Sheet No 3(B). See Stitch Pattern Sheet No 11(B).

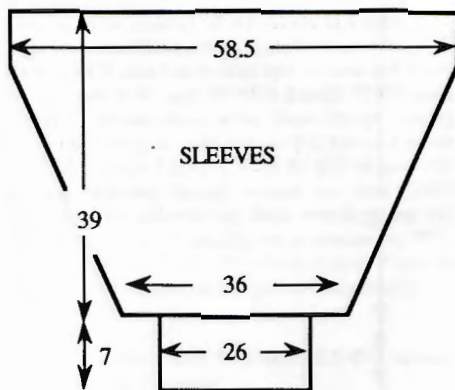
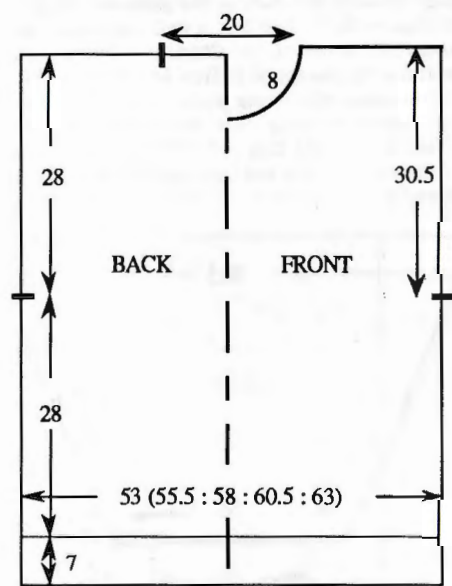

### PROCEDURE (See STEP-BY-STEP)

Make a tension swatch and set KL accordingly. Make a tension swatch and set KL accordingly. Draw the picture design onto KL sheet as desired together with garment diagram. It is possible to use KL sheet to indicate the picture and follow the garment instructions simultaneously.

### BACK

"STRIPED" - using A, "WINDMILL" using M, cast on over 135 (141, 147, 155, 161) KH Ns as RIB. "TULIPS" - using A cast on over 134 (142, 146, 154, 162) KH Ns as RIB, 000. Knit to RC30. Trans all sts to KH, "TULIPS" inc 2 (0, 2, 2, 0) sts. 000, T10 knit to RC100. Place a WY marker at each end of work. "STRIPED" and "WINDMILL" knit to RC200, waste knit centre 51 sts, waste knit rem 42 (45, 48, 52, 55) sts at each end for shoulders. "TULIPS" knit to RC187, using A knit 1 row, trans to RIB (see RIB) T5/5, knit to RC201 T10/8 knit 1 row and trans all sts to KH and latch cast off.

### FRONT

As BACK, "STRIPED" and "WINDMILL" to RC180, "TULIPS" to RC168, COR.

### "STRIPED" and "WINDMILL" -

#### Neck shaping

Waste knit centre 19 sts. Waste knit sts at left, COR. Knit 1 row. At beg of next and every foll alt row cast off 3 sts x 2, 2 sts x 3, then dec 1 st x 4. Knit to RC210 and waste knit rem 42 (45, 48, 52, 55) sts. Return sts at left to Ns and knit to match right side reversing shapings.

### "TULIPS" - Neck shaping and NECK-BAND

Push centre 26 Ns into HP. Push all Ns at left into HP. Set K-Carr to H. (Always taking yarn round inside N to prevent a hole forming) knit 2 rows. At left on next and every foll alt row, push into HP 2 Ns x 9. Push rem Ns into HP for shoulder. COL, return Ns at left to UWP and knit to match right side reversing shapings. Using A T10 knit 1 row over all Ns. Trans to RIB, 000. T5/5 knit to RC11. T10/8 knit 1 row. Trans all sts to KH and latch cast off.

### "STRIPED" - NECKBAND

\*Join one shoulder by placing one set of shoulder sts back onto Ns with right sides together. Using M T10 knit 1 row and cast off. Push 123 KH Ns into WP. With right side facing, pick up same number of sts evenly along neck edge and place onto Ns.\* Using A T10 knit 1 row. Trans to RIB, 000. Knit to RC24. Trans all sts to KH. T10 knit 2 rows and waste knit. \*\*Join second shoulder as first. Join NECKBAND seam and fold in half to outside and backstitch to garment through last row knitted in A.\*\*

### "WINDMILL" - NECKBAND

Repeat from \* to \*, 000. Using M T10, dec tension by ° every 2 rows, knit to RC12. T10 knit 1 row. T8°, inc tension by ° every 2 rows, knit to RC27 and waste knit. Repeat from \*\* to \*\* reading A as M.

### "STRIPES" - SLEEVES

Push 149 KH Ns into WP. With wrong side facing, pick up same number of sts evenly along armhole edge between WY markers and place onto Ns, 000. Working Stripe Patt in reverse order, knit to RC24. Dec 1 st at each end of next and every foll 4th row x 29. Knit to RC140 and waste knit rem 91 sts. CUFFS: Push 67 KH Ns into WP. With wrong side facing, place sts from CUFF edge back onto Ns distributing them evenly along the row. Using A T10 knit 1 row. Trans to RIB, 000. Knit to RC29. T10/8 knit 1 row. Trans all sts to KH and latch cast off.

### "WINDMILL" - SLEEVES

As "STRIPES" using M throughout.

### "TULIPS" - SLEEVES

Join shoulders leaving 24cm open at centre. Push 153 KH Ns into WP. With wrong side facing, pick up same number of sts evenly along armhole edge between WY markers and place onto Ns, 000. Using M knit to RC18, dec 1 st at each end of next and every foll 4th row x 30 and, AT THE SAME TIME, work Stripe/Fairisle Patt as follows:-

Rows	FA	FB	Area
6	M only		
5	M	B	1
5	M	C	1
4	M only		
4	G only		
2	M only		
6	M	D	2
2	M only		
6	H only		
4	M	E	3
4	M only		
6	M	A	4
2	M only		
8	M	F	5
2	M only		
4	M	B	6
4	M only		
2	D only		
13	M	G	7
2	M only		
2	M	D	8
2	M only		
2	M	D	8
3	M only		
2	C only		
2	F only		
4	M only		
7	M	H	9
1	M only		
7	M	B	9
3	E only		
3	M only		
4	G only		
3	M only		

Waste knit rem 93 sts. CUFFS: Push 66 KH Ns into WP. With wrong side facing, place sts from CUFF edge back onto Ns distributing them evenly along the row. Using A T10 knit 1 row. Trans to RIB, 000. Knit to RC29. T10/8 knit 1 row. Trans all sts to KH and latch cast off.

### MAKE-UP

Block and press. Join side and SLEEVE seams.



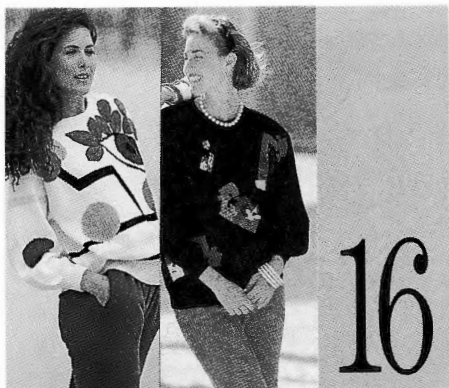

**MACHINES:** A, C or D with Intarsia facility or Intarsia Carriage with KL, and KR. **MATERIALS:** "Eye" YEOMAN YARNS Cannele; M - 700 (720, 740, 760, 780)g (White 6), small amounts in each of A - (Black 30), B - (Powder Pink 7), C - (Cardinal 27), D - (Glycine 15), E - (Candy Floss 36), F - (Prairie 25), G - (Orient 16), "Jigsaw" YEOMAN YARNS Cannele; M - 700 (720, 740, 760, 780)g (White 6 or Black 30), small amounts in each of A - (Prairie 25), B - (Orient 16), C - (Turquoise 140), D - (Ruby 38), E - (Red 26), F - (Saffron 23). (100% Cotton 350m/100g). **MEASUREMENTS:** To fit bust 86 (91, 96, 101, 106)cm. **TENSION:** St st/Intarsia (when making your tension swatch use Intarsia Carr if you intend to work the garment with the intarsia Carr - Intarsia Carr and K-Carr tensions can be very different - 40 sts = 12.6cm and 60 rows = 14.3cm (approx T8) after washing, blocking and pressing. **RIB:** 1 x 1 T1/1. **NOTES:** "Eye" and "Jigsaw" - BACK and SLEEVES are in st st only. "Eye" - work stripes on BACK to correspond with those on the FRONT. Except where otherwise stated instructions are given for both garments. See Stitch Pattern Sheet Nos 10(A) and (E). For diagram see Patt No 15.

#### PROCEDURE (see STEP-BY-STEP)

Make a tension swatch and set KL accordingly. Draw the chosen picture design onto the KL Sheet together with FRONT diagram. It is possible to use the KL to indicate the intarsia designs and follow the garment instructions simultaneously.

#### BACK

Using M cast on over 169 (177, 185, 193, 199) KH Ns as RIB, 000. Knit to RC36. Trans all sts to KH, 000. T8\* Knit to RC118. Place a WY marker at each end of work. Knit to RC236. Waste knit centre 63 sts. Waste knit rem 53 (57, 61, 65, 68) sts at each end of work for shoulders.

#### FRONT

As BACK to \*. Working in Intarsia throughout, knit to RC118. Place a WY marker at each end of work. Knit to RC212.

#### Neck shaping

Waste knit centre 23 sts. Waste knit sts at left, COR. Knit 1 row. At beg of next and every foll alt row cast off 4 sts x 1, 3 sts x 2, 2 sts x 3, then dec 1 st x 4. Knit to RC256 and waste knit rem 53 (57, 61, 65, 68) sts. Return sts at left to Ns and knit to match right side reversing shapings.

#### NECKBAND

Join one shoulder by placing one set of shoulder sts back onto Ns with right sides together. Using M T10 knit 1 row and cast off. Push 152 KH Ns into WP. With right side facing, pick up same number of sts evenly along neck edge and place onto Ns, 000. Using M and starting with T7 knit 12 rows dec the Tension by ° every 2 rows. T10 knit 1 row. Starting with T5° knit to RC27 inc the Tension by ° every 2 rows. Waste knit. Join second shoulder as first. Join NECKBAND seam, fold in half to outside and backstitch to garment through last row knitted in M.

#### SLEEVES "Eye"

Push 186 KH Ns into WP. With wrong side of garment facing pick up same number of sts evenly along armhole edge between WY markers, and place onto Ns, 000. Using M knit to RC20. Dec 1 st at each end of next and every foll 4th row x 36, \*\* and, AT THE SAME TIME, using B knit 10 rows, using M \*\* knit to RC164 and waste knit rem 114 sts. **CUFFS:** Push 83 KH Ns into WP. With wrong side facing, place sts from cuff edge onto Ns distributing them evenly along the row. Using M T8 knit 1 row. Trans to RIB, 000. Knit to RC35. T10/8 knit 1 row. Trans all sts to KH and latch cast off.

#### SLEEVES "Jigsaw"

As "Eye" excluding \*\* to \*\*.

#### MAKE-UP

Wash, block and press. Join side and SLEEVE seams. "Eye" Using A embroider around "leaves" as illustrated. "Jigsaw" using Black work 'French Knots' in centre of each piece of 'Jigsaw' as illustrated.

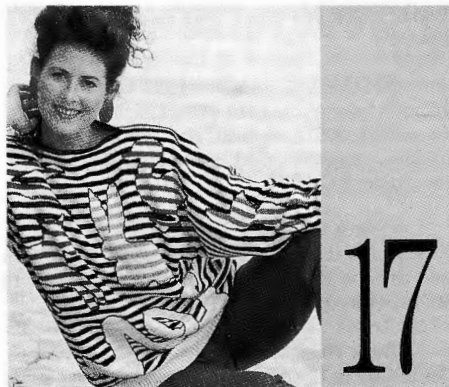

**MACHINES:** A, C or D with Intarsia facility or Intarsia Carriage, KR and KL. **MATERIALS:** ROWAN YARNS Soft Cotton; M - 300 (320, 340, 360, 380)g (White 521), A - 250 (270, 290, 310, 330)g (Black 526), small amounts in each of B - (True Blue 541), C - (Purple 543), D - (Burnt Orange 550), E - (Signal Red 532), F - (Spring Yellow 536), G - (Caramel 524), (100% cotton 395m/100g). **MEASUREMENTS:** To fit bust 86 (91, 96, 101, 106)cm. **TENSION:** St st/Intarsia (when making your tension swatch use Intarsia Carr if you intend to work garment with Intarsia Carr - Intarsia Carr and K-Carr tensions can be very different) - 40 sts = 12.8cm and 60 rows = 16cm (approx T9) after washing, blocking and pressing. **RIB:** 1 x 1 T2/2. **NOTES:** Stripe Patt - 4 rows A, 4 rows M. Stripes for Animals are in 4 rows M, 4 rows chosen Con Col as illustrated. See Stitch Pattern Sheet Nos 11(C), 12(A), (B), (C) and (D).

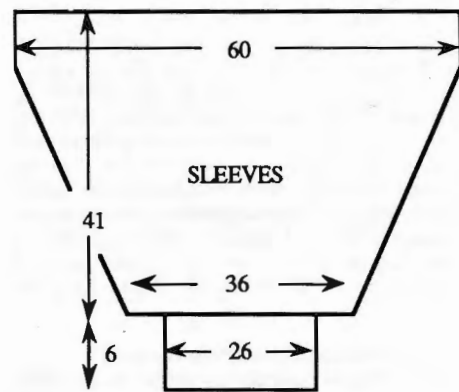
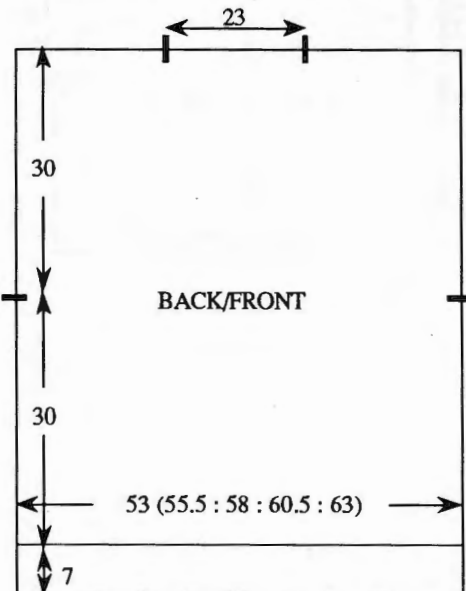

#### PROCEDURE (see STEP-BY-STEP)

Make a Tension swatch and set KL accordingly. Draw garment diagram and 'Animal' shapes as required onto KL Sheet. It is possible to use KL Sheet to indicate the 'Animals' and following the garment instructions simultaneously.

#### BACK/FRONT

Using M cast on over 165 (173, 181, 189, 197) KH Ns as RIB, 000. Knit to RC37. Trans all sts to KH. T9 knit 1 row, 000. Working in Stripe Patt throughout knit to RC112. Place a WY marker at each end of work. Knit to RC226. Waste knit 46 (50, 54, 58, 62) sts at each end of work for shoulders. Using A T10 knit 1 row. T7 Knit 2 rows. Using M knit 4 rows and cast off rem 73 sts loosely.

#### RIGHT SLEEVE

Using WY cast on over 128 KH Ns and knit a few rows ending with COL, 000. T9 working in Stripe Patt throughout, at right push into HP 115 KH Ns, (always taking yarn round inside needle to prevent a hole forming) knit 2 rows. On next and every foll alt row at right take back to UWP 5 KH Ns x 23. Knit to RC182. At right on next and every foll alt row push into HP 5 KH Ns x 23. Waste knit over all sts. **CUFFS:** Push 81 KH Ns into WP. With wrong side facing, pick up same number of sts evenly along CUFF edge and place onto Ns. Using M T9 knit 1 row. Trans to RIB, 000. Knit to RC29. T10/8 knit 1 row. Trans all sts to KH and latch cast off.

#### LEFT SLEEVE

As RIGHT SLEEVE reversing shapings by reading right for left and vice versa.

#### MAKE-UP

Join shoulders by placing both sets of shoulder sts back onto Ns with right sides together. Using A T10 knit 1 row and cast off. Using mattress stitch join top of SLEEVES to armhole between WY markers, matching Stripes. Fold Neck Facing to inside and stitch down loosely. Using A embroider around each 'Animal' as illustrated. Wash, block and press. Join side and SLEEVE seams.



**MACHINES:** A, C or D with Intarsia facility or Intarsia Carriage with KL, and KR. **MATERIALS:** ROWAN YARNS Soft Cotton; M - 220 (230, 240, 250, 260)g (True Blue 541), A - 170 (180, 190, 200, 210)g (Bleached 521), small amount of B -



(Burnt Orange 550). (100% Cotton 395m/100g). Elastic to fit waist + 2.5cm. **MEASUREMENTS:** To fit height 110 (116, 122, 128, 134)cm, approx chest 59 (61, 63, 66, 69)cm. **TENSION:** St st/Intarsia (when making your tension swatch use Intarsia Carr if you intend to work garment with Intarsia Carr - Intarsia Carr and K-Carr tensions can be very different) - 40 sts = 12.8cm and 60 rows = 16cm (approx T9) after washing, blocking and pressing. **RIB:** 1 x 1 T2/2. **NOTES:** Stripe Patt - 4 rows A, 4 rows M. Stripes for 'Tortoise' are in 4 rows A, 4 rows B. See Stitch Pattern Sheet No 9(B).

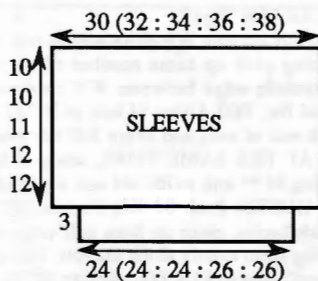

evenly along armhole edge between WY markers and place onto Ns, 000. T9 working in Stripe Patt throughout knit to RC38 (38, 42, 46, 46) and waste knit. **CUFFS:** Push 75 (75, 75, 81, 81) KH Ns into WP. With wrong side facing, place sts from cuff edge onto Ns distributing them evenly along the row. Using A T9 knit 1 row. Trans to RIB, 000. Knit to RC11. T10/8 knit 1 row. Trans all sts to KH and latch cast off.

#### PROCEDURE (see Step-by-Step)

Make a Tension swatch and set KL accordingly. Draw Tortoise and garment diagram onto KL Sheet. It is possible to use KL Sheet to indicate the Tortoise shape and follow the garment instructions simultaneously.

#### TOP BACK

Using A cast on over 103 (107, 109, 115, 121) KH Ns as RIB, 000. Knit to RC11. Trans all sts to KH. T9 knit 1 row, 000. Using M knit to RC60 (68, 78, 90, 98). Place a WY marker at each end of work. Knit to RC112 (124, 138, 154, 166). Waste knit centre 43 sts. Waste knit rem 30 (32, 33, 36, 39) sts at each end of work for shoulders.

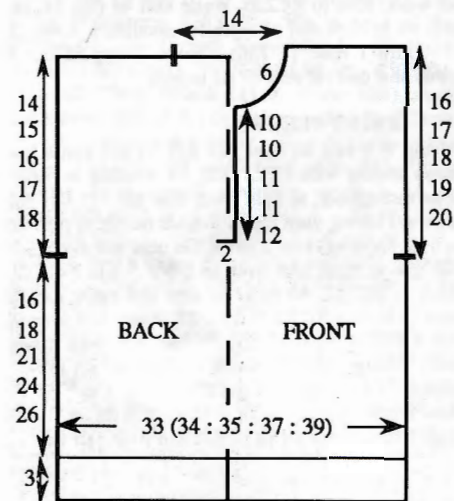

**FRONT**  
As BACK to RC60 (72, 82, 98, 106).

#### Front opening

Cast off centre 7 sts. Waste knit sts at left, COR. Knit to RC99 (111, 125, 141, 153).

#### Neck shaping

At beg of next and every foll alt row cast off 4 sts x 1, 3 sts x 2, 2 sts x 2, then dec 1 st x 4. Knit to RC120 (132, 146, 162, 174) and waste knit rem 30 (32, 33, 36, 39) sts. Return sts at left to Ns and knit to match right side reversing shapings.

#### NECKBAND

Join shoulders by placing both sets of shoulder sts onto Ns with right sides together, using M T10 knit 1 row and cast off. Using A cast on over 99 KH Ns as RIB, 000. Knit to RC8. Trans all sts to KH. T9 knit 1 row. With wrong side facing, pick up same number of sts evenly along neck edge and place onto Ns. T10 knit 1 row and cast off.

#### FRONT BANDS

Using A cast on over 37 (37, 41, 41, 45) KH Ns as RIB, 000. Knit to RC8. Trans all sts to KH T9 knit 1 row. With wrong side facing, pick up same number of sts evenly along FRONT opening edges and place onto Ns. T10 knit 1 row and cast off.

#### SLEEVES

Push 93 (100, 106, 112, 118) KH Ns into WP. With wrong side facing, pick up same number of sts

#### MAKE-UP

Wash, block and press. Join side and SLEEVE seams.

#### SHORTS - RIGHT LEG

Using A cast on over 113 (119, 125, 131, 137) KH Ns as RIB, 000. Knit to RC11. Trans all sts to KH. T9 knit 1 row, 000. Working in Stripe Patt throughout, knit to RC38 (38, 42, 42, 42).

#### Crotch shaping

At beg of next 2 rows cast off 2 sts. Dec 1 st at each end of next and every foll alt row x 5. Knit to RC102 (106, 112, 116, 120), COR.

#### Back Waist shaping

Set K-Carr to H. (Always taking yarn round inside N to prevent a hole forming) at left on next and every foll alt row push into HP 50 (53, 56, 59, 62) Ns x 1, 10 Ns x 3. Set K-Carr to N. Knit 1 row over all Ns. **WAISTBAND:** Trans to RIB, 000. Using A knit to RC21. T10/8 knit 1 row. Trans all sts to KH and latch cast off.

#### LEFT LEG

As RIGHT LEG reversing shapings.

#### MAKE-UP

Wash, block and press. Join Front and Back seams. Join inside LEG seams. Fold WAISTBAND in half to inside and catch down loosely encasing elastic.

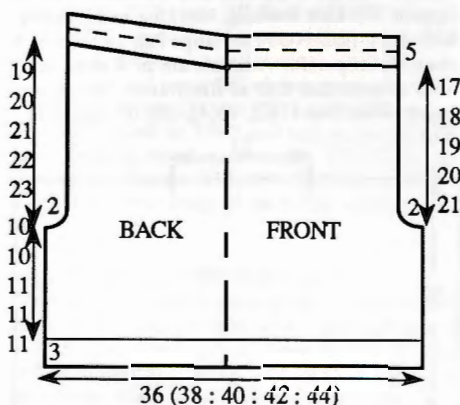

**MACHINES:** A, C or D with Intarsia facility or Intarsia Carriage with KL, and KR. **MATERIALS:** ROWAN YARNS Soft Cotton; M - 220 (240, 260, 280, 300)g (Signal Red 532), A - 100 (120, 140, 160, 180)g (Bleached 521), small amounts of B - (Spring Yellow 536) and C - (True Blue 541). (100% cotton 395m/100g), 7 buttons. Elastic to fit waist + 2.5 cm. **MEASUREMENTS:** To fit height 110 (116, 122, 128, 134)cm approx chest 59 (61, 63, 66, 69)cm. **TENSION:** St st/Intarsia (when making your tension swatch use Intarsia Carr if you intend to work garment with Intarsia Carr - Intarsia Carr and K-Carr tensions can be very different) - 40 sts = 12.8cm and 60 rows = 16cm (approx T9) after washing, blocking and pressing. **RIB:** 1 x 1 T2/2. **NOTES:** Stripe Patt - 4 rows A, 4 rows M. Stripes for 'Animals' are in 4 rows A, 4 rows B or C as illustrated. See Stitch Pattern Sheet Nos 9(G) and 11(A).

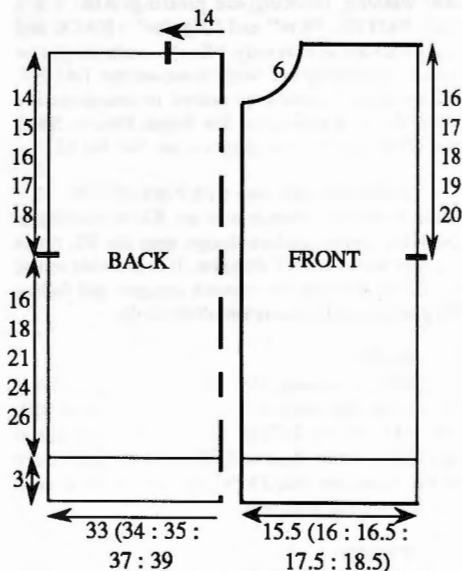

#### PROCEDURE (see STEP-BY-STEP)

Make a Tension swatch and set KL accordingly. Draw animal shapes and FRONT diagram onto KL Sheet. It is possible to use KL Sheet to indicate the animal shapes and follow the garment instructions simultaneously.

#### CARDIGAN BACK

Using A cast on over 103 (107, 109, 115, 121) KH Ns as RIB, 000. \* Knit to RC11. Trans all sts to KH. T9 knit 1 row, 000. Using M knit to RC60 (68, 78, 90, 98)\*. Place a WY marker at each end of work. Knit to RC112 (124, 138, 154, 166). Waste knit centre 43 sts. Waste knit rem 30 (32, 33, 36, 39) sts at each end of work for shoulders.

#### RIGHT FRONT

Using A cast on over 49 (51, 53, 55, 59) KH Ns as RIB, 000. Repeat from \* to \*. Place a WY marker at right end of work. Knit to RC99 (111, 125, 141, 153), COL.

#### Neck shaping

At beg of next and every foll alt row cast off 5 (5,



# CLUB NEWS

from MACHINE  
KNITTING FASHION

We are trying to keep all the information we print up to date. Club Leaders will receive a note from us every three months asking for their latest details. Once received, it is that which is published in the current issue. Please help us by returning your form as soon as possible! In the meantime we would like to thank Club Leaders for their hard work and very jolly letters. If you would like a mention in Club News No.7 please make sure that you contact us on or before 2nd June. Please send all correspondence to Susan Nutbeam, Machine Knitting Fashion, 5 Dryden Street, London WC2E 9NW.

## Hitting the headlines

Ernie Pallett, retired engineer, machine knitter, and student of Rita Skeels, has been hitting the headlines with his wonderful "railway engine" sweater. Co-designed with his grandson, Ernie's efforts were reported on the Fashion Page of the Evening Telegraph! Rita Skeels, who has been kind enough to pass on this snip bit of information, says that she is ready to coach and encourage more people to machine knit! See Clubs and Classes - listed under Peterborough.

## No age barrier

Many thanks to Dawn Lawrence who writes to say that since the White Horse Machine Knitting Club has moved into the Community Centre last year their membership has risen greatly! She says they are a nice group of ladies who age from about 14 years old! See Clubs and Classes listed under Swindon.

## Busy, busy, busy

That's Gloria Thomas who continues to run her shop - The Cat's Wiskers - along with

Ludlow Knitting Club AND Evening Classes! Gloria writes a wonderful letter which is pages long, and being a designer as well as manager and organizer, is full of ideas. One idea which Gloria has introduced to Ludlow Machine Knitting Club which other Clubs may be interested in is a "Showing off" session. Members bring along anything new they have bought or found and show it off to the others - a sort of moving catalogue! For full details of where to contact Gloria see Clubs and Classes - listed under Ludlow.

## Change of leadership

Angie Holloway, who did a great job organizing Woking Machine Knitting Club over the last few years, has now retired her position and Doreen Throssell has agreed to take her place - a tough act to follow we imagine! Doreen has already set the pace for the year by organizing interesting meetings for the Members up to July of this year. Unfortunately, owing to our publishing dates we are too late to report on the first part of the year, however scheduled for May is a Weaving demonstration, June is still to be arranged, and in July Rosalie Davis will talk about her unusual designs. For further information see Clubs and Classes - listed under Woking!

## Dropinstitches in Majorca

It seemed a crazy idea - 40 people abroad on a Knitting Holiday. The pitfalls are many, the organization enormous, but for Knitaholics the holiday was a dream come true! Read this account of last year's trip, written by Helen of Dropinstitches, and then decide if you want to join Dropinstitches this year!

"We had thirty-seven people actually flying with us from Luton Airport including Janet and I, Peggy Crighton and John Blakeman from Brother and Keith Hammond representing King Cole Ltd., who sponsored our yarn supply. All our machines, 4 electronics, 1 ribber, 2 colour changers, 2 PPD's 2 Disk Drives and a TV set were lent to us by Brother.

## FRIDAY

At last the great day dawned and at 5.30 a.m. John and I were at Luton Airport hoping to sort out ticket mistakes and check our equipment in. All our tickets had been wrongly issued as half board and our Carnet for transporting our machines had to be stamped and checked. This was our first hiccup, it was overcome and we apprehensively began our journey. Would our equipment survive the flight, I had lost my luggage before at an airport and I began to think of all the alternative courses we could offer on our subject without using machines.

I need not have worried though, our machines arrived and my next hurdle was customs. The British customs at Luton warned that the Spanish had probably not encountered many of the documents I was taking and it took

some time for me to emerge. That now over we all confidently set forth on our coach to our destination Magaluf and our hotel the Guadalupe.

When we arrived the staff were marvelous. Our rooms were allocated and our conference rooms were prepared very quickly. We began our first session at 3.00 p.m. and were joined by three ladies already staying on the island. We now had our party of 40 complete.

T-shirts, badges and stickers were handed out to all and we began our tutorials. The group was split into three and the subjects were rotated until we completed our sessions. The food was buffet style and very good. I am notorious a fussy eater, and vegetarian, so the hotel did extremely well if it satisfied me. Everybody else felt the same and after we had eaten we all enjoyed the facilities of the hotel. A cabaret and dance was available every evening, and there was an indoor swimming pool.

Our party consisted of 3 couples, an additional two men and the rest were ladies who soon made friends with each other. Our insurance company were a little worried for the safety of the five men in our group and offered extra insurance for them!!



## SATURDAY

We altered our proposed teaching times to coincide with the siesta. We had morning and afternoon sessions to work through, then there was plenty of free time to engage in local activities. John converted our King Cole rep. Keith to the joys of the PPD and Peggy did her bit on the 950i. We were going to make a Knitter of him yet! We had some strange reactions from those around us in the hotel. Because of our white T-shirts and stickers and our Brother badges proclaiming "I love my Brother" some of the hotel residents asked us what religious sect we belonged to!! Some of our party were asked by a local English resident if we would look at her Brother sewing machine while on the island, as she was unable to use it. Peggy gamely promised to visit the lady and this was arranged for the Monday.

A Hypnotist was our cabaret that night and we were surprised to find that one of our ladies succumbed and was in a trance on the stage with other hotels guests. None of us, including herself, realized her violin playing potential and it was all very entertaining. Four of the tutors had formed a card school in



Canasta and the score was one all. The decider was to be played on the Sunday.

### SUNDAY

Four sessions again today, plus a meal together and a competition and quiz on our holiday. At the end of the afternoon our 3 resident ladies in Majorca thanked us and asked about our next holiday. That was a shock, we hadn't really considered having another holiday, but we were all having such a good time in each others company, all with a common interest that the tutors amongst us began to make plans. The seed planted we decided on Malta as our next venue at the same time of year.

I haven't mentioned the weather yet, it was pleasantly warm T-shirt weather and a cardigan was needed to stroll outside in the evening. Back in England we were told the temperature was minus 7 so we were all glad to be where we were.

Our meal consumed we commenced our Quiz which was based entirely on our holiday. The prize was a Brother/Rowan book donated by Brother and was eagerly accepted by the winner. Other prizes of cones were donated by King Cole Limited and presented by Keith. Our Spanish Theme Sweater Competition judged by Peggy, John and Keith was amazing. The talent of the ladies in our party was a joy to see. The funniest was from Doris with three dimensional figures (including herself as a little old lady) dangling on the front of the sweater. The winner was Margaret George with a flamenco dancer on the front

and bull on the back. The prize was six cones of King Cole Anti-Tickle pure wool. Everyone was keen to win this as we had been given quite a detailed talk by Keith on this yarn and it had performed so well during the course.

The photographs of our group completed we retired to our pleasures, which in our case was the final of the Canasta game. John and Janet emerged as the winners, and we celebrated with a 1 a.m. paddle on the beach!!

### MONDAY

With all the machines packed as well as our suitcases we were all set to explore Palma Nova and complete our shopping. We had escaped the frantic Christmas preparations and it was a pleasure just to amble about. Cockney Harry's was our first port of call to see to the Brother Sewing Machine. Peggy deftly sorted out the problem and we were gratefully given a bottle of wine in exchange for our help. Our shopping completed, our wine drunk, we prepared for our return journey and loaded our luggage and machines onto our coach airport bound.

Mild panic ensued on our arrival when our vital customs papers couldn't be stamped as there was no customs official around for over an hour. Our suitcases and party had boarded the plane and we were still waiting with our equipment. At last our papers were hastily stamped, the plane delayed 5 mins and we boarded the plane to join the others, hoping our equipment was with us. It was!! The

panic was over, a reunion planned so we could exchange photos and watch the video that Les had taken. All were keen to join us again in Portugal next year when this time we shall increase our party to 60. Details of next venture are available from:- Dropinstitches Machine Knitting Centre, 3 Bedwell Park, Bedwell Crescent, Stevenage, Herts, SG1 1NB. Tel: 0438 725155.

### Full diary for Latton Bush

Latton Bush Machine Knitting Club are still keeping themselves very busy. Their meetings are spent from 8.00 p.m. - 8.30 p.m. - problem solving, 8.30 p.m. - 9.15 p.m. demonstration and from 9.15 p.m. - 10.00 p.m. raffle, tea, coffee and chat - which seems a good way to spend an evening! During the month of May they will be taking a closer look at Cables - 2nd May, Tension squares - 9th May, More use of the Ribber - 16th May and How to make your own pattern - 25th May. For more Club details and person to contact see CLUBS AND CLASSES.

### Pen pal wanted

Mrs. Julie Euripidou emigrated to, and now lives in, Limassol, Cyprus and would dearly love to have a penpal. Julies says that she has a Brother KH836 knitting machine with ribbing attachment and would like to swop ideas

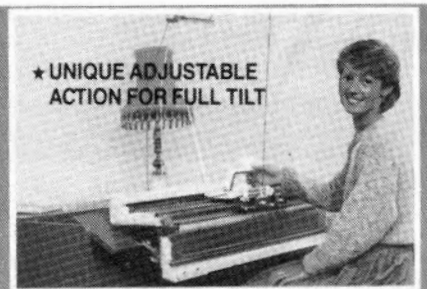
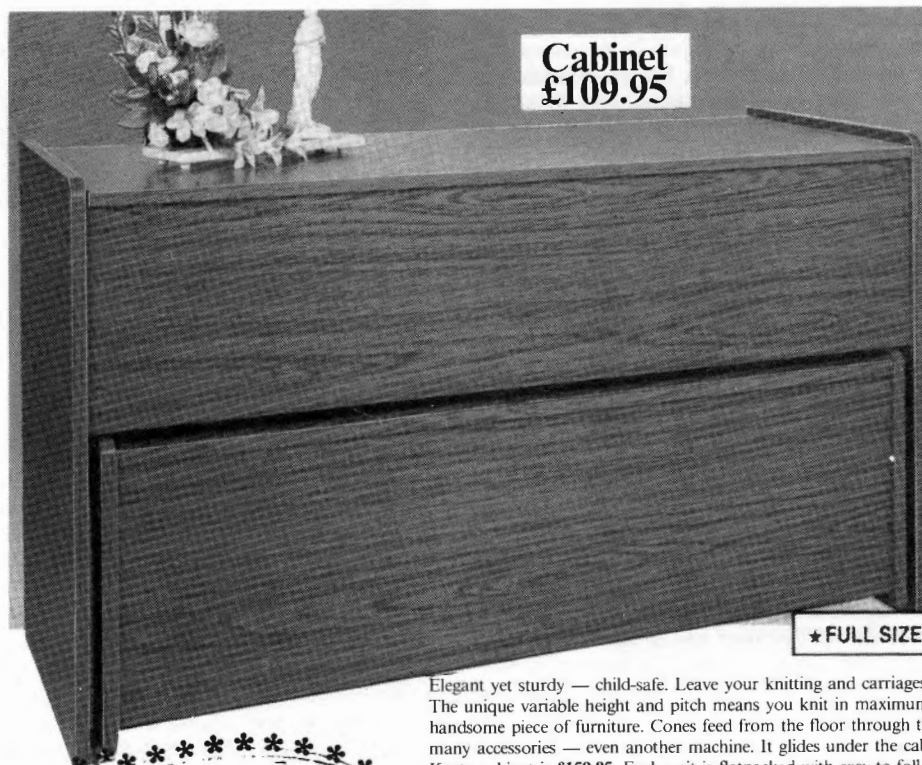

★ FULL SIZE BENCH

Elegant yet sturdy — child-safe. Leave your knitting and carriages on — just slide away your machine and ribber in seconds. The unique variable height and pitch means you knit in maximum comfort. The slideaway action converts your cabinet into a handsome piece of furniture. Cones feed from the floor through the base of the cabinet. The bench if ordered will store cones and many accessories — even another machine. It glides under the cabinet on strong easy run castors. Complete with a bench the Keyto cabinet is £159.95. Each unit is flatpacked with easy-to-follow assembly instructions. Choose yours from simulated Warm Natural Teak or Traditional Walnut. Dimensions: 48½" x 27½" x 18½". Please allow 28 days for delivery. Delivery £10 UK Mainland only.  
**Keyto Cabinet and Bench: RRP £199.95. Cash offer price £159.95 plus carriage**  
 Credit Terms: £17 deposit and 12 monthly payments of £15.04. Save £40.00.  
 Total HP Price: £197.48 inclusive of carriage. APR 36.75%.  
**Keyto Cabinet only: RRP £139.95. Cash offer price £109.95 plus carriage.**  
 Credit Terms: £12 deposit and 12 monthly payments of £10.62. Save £30.00.  
 Total HP Price: £139.44 inclusive of carriage. APR 36.75%.  
 Credit Brokerage No. 181346.

PRICES DOWN

Keyto Magic

**KEYTO**  
 Unit 2, Halliwell Industrial Estate,  
 Wapping Street, Halliwell Road,  
 Bolton BL1 8DN. Tel: 0204 491515



and information with all - she promises to answer all who write to her! Full address: Mrs. Julie Euripidou, 20 Kalamatas St., Kapsalos TT 246, Limassol, Cyprus.

### *A tribute to Eileen*

Eileen Mackie was the inspiration and strength behind the Runcorn Machine Knitting Club and will be sadly missed by all her family and friends. The Club, now six years old is now run by Mrs. A. Owen. For further details of the Runcorn Club see **CLUBS AND CLASSES**.

### *Still going after 11 years*

Fleet Machine Knitting Club is now enjoying its eleventh year writes Mrs. N. Cornwell. They currently meet in Member's homes and so have to restrict the membership to 2 dozen. However, due to much increased interest they are moving to a small hall and hope to increase their membership! For further details of Fleet Machine Knitting Club see **CLUBS AND CLASSES**.

### *Knitwear for all seasons*

Parkside Machine Knitting Club will stage their 3rd Charity Fashion show at Parkside Community Centre, Goodmayes Lane, Goodmayes, Ilford, Essex, on Thursday 10th and Friday 11th May. Doors open at 7.30 p.m. and tickets are £2.00 each. There is a Bar and a Tea Bar at the centre so plenty of refreshments will be available. Behind the scenes Joyce Gale (apologies for the mistake last issue) says she has "all hands to the Carriage" as opposed to the wheel! For further details of Parkside Machine Knitting Club see **CLUBS AND CLASSES**.

### *£1,340 raised for chemotherapy unit*

We can all imagine how tickled pink Audrey Penn and the other Members of the Aldridge Machine Knitting Club were at the realisation that their Fashion Show raised the above amount. Well done Aldridge! Full details of the Aldridge Machine Knitting Club can be found in **CLUBS AND CLASSES**.

### *Help and wonderful company*

Vera Monger writes to say that due to unforeseen circumstances she is no longer able to continue with her Club. However, she has kindly offered to help anyone who is in difficulties - Vera is very experienced and has a KH950i and PPD - and says that she is happy to receive visitors and telephone calls! Contact: Vera Monger, 29 Amersham Ave., West View Park, Langdon Hill, Basildon, Essex. Tel: 0268 417098.

# CLUBS AND CLASSES

## ENGLAND GREATER LONDON

**CAMDEN** - Machine Knitting Classes - (Beginners) Tuesdays, from 10.00 a.m. to 12.30 p.m., (Intermediate/Advanced) Tuesdays from 4.00 to 6.30 p.m. (all levels) Tuesdays from 7.00 p.m. to 9.30 p.m. Advanced Classes are held at Camden Adult Education Institute, 86 Holmes Road, NW5 3AX. Contact: Margot Barker, Senior Lecturer, Fashion, Textiles and Crafts, Camden Adult Education Centre, at the above address. Tel: 01 267 1414.

**LONDON - DULWICH** - Dulwich Machine Knitting Club meet on the second Monday of each month from 7.00 to 9.00 p.m. at 59 Beauval Road, Dulwich SE22 8UG. Contact: Kathy Beere at the above address.

**LONDON - WESTMINSTER** - Westminster Adult Education Centre will be offering the NEW City and Guilds Machine Knitting Course beginning in September 1990. This is a two year course designed to marry machine knitting techniques with a strong foundation in Art and Design. There will be integrated classes in all aspects of colour, design, art and machine knitting technology. This course is designed to bring out creativity and imagination in the keen student. We are looking for the student who is curious and questioning and enthusiastic; willing to explore new avenues and open doors. Students will be expected to study for 6 hours in first year, 4 hours in second year. For further details please phone 01 286 1900.

## HERTFORDSHIRE AND MIDDLESEX

**HERTFORD** - Evening Classes are held at various times at Ware College and hopefully a Residential Class, all is not confirmed yet! Also on Friday mornings at Sawbridgeworth there is a Class for the visually disabled but also physically disabled people may join them, please check with Joanna as there are some steps etc. Contact: Joanna Nelson, 9 Postwood Green, Hertford, SG13 7QJ. Tel: 0992 584876.

**NORTH HARROW** - The Janes Machine Knitting Club meet at various venues. Contact: Mrs. Gladys Janes, 6 Kingsway Crescent, North Harrow, Middlesex, HA2 6BG. Tel: 01 427 6842.

**ST. ALBANS** - The Park Street Machine Knitting Club meets every second Monday of each month from 7.30 to 9.30 p.m. at the Park Street Village Hall. Contact: Mrs Marjory Singleton, 33 Jerome Drive, St. Albans. Tel: 0727 60627.

**STEVENAGE** - Dropinstitches Machine Knitting Club meet (Duomatics) on the first Thursday of each month from 1.00 to 3.00 p.m. and (Japanese Electronics) on the first Thursday of each month from 8.00 to 10.00 p.m. and (all Machines) on the second and last Thursday of each month from 1.00 p.m. to 3.00 p.m. and 8.00 to 10. p.m. all at Dropinstitches, 3 Bedwell Park, Bedwell Crescent, Stevenage, Herts. SG1 1NB. Contact: Mrs. J. Purvis or Mrs. H. Loudwell. Tel: 0438 725155.

**WEST DRAYTON** - Feltham Machine Knitting Club meet on the second Thursday of each month from 7.30 p.m. at The Feltham School, Brawells Lane, Feltham, Middx. Contact Mrs. Frances Goodman, 36 Blossom Way, West Drayton, Middx UB7 9HF. Tel: 0895 443880.

## KENT

**BROMLEY** - Both Day and Evening Adult Education Classes from Beginners to, and including, City and Guilds at various venues in the Bromley area. Contact: Barbara Garratt, 37 Kynaston Road, Bromley, Kent BR1 5AN. Tel: 01 464 5745 or 01 460 8812.

**CANTERBURY** - The Canterbury Machine Knitting Club meet on the third Wednesday of each month from 7.30 to 9.30 p.m. at Jubilee Hall, Wincheap, Canterbury, Kent. Contact: Irene Benson, Gore Farm House, Six Mile, Stone Street, Stelling Minnis, Kent. CT34 6DW. Tel: 0227 87373.

**CHATHAM** - Walderslade Knitting Club meets on the second Wednesday of each month from 7.30 p.m. to 9.30 p.m. at 34 Sherwood Avenue, Walderslade, Chatham, Kent ME5 9PR. Contact Mrs. G. Everette. Tel: 0634 862137

**ORPINGTON** - Orpington Machine Knitting Club meets third Wednesday every month 1.30 p.m. to 4 p.m. or 7.30 p.m. to 9.30 p.m. Also New Electronic Club meets first Thursday every month 7.30 p.m. to 10 p.m. at 5 Irene Road, Orpington, Kent. Contact: Pat Steven at above address. Tel: 0689 21802 or Jean Woollard 23 Sandhurst Road, Orpington. Tel: 0689 75910.

**ROCHESTER** - The Frindsbury Extra Machine Knitting Club meets on the first Wednesday of each month from 7.30 to 10 p.m. at Shawswood Daycare Centre, Mill Road, Strood, Rochester, Kent. Contact: Mrs Rosemary Richardson, Holly Villa, 58



Hollywood Lane, Frindsbury Extra, Rochester, Kent ME3 8AR. Tel: 0634 717563.

**SNODLAND** - The Snodland Machine Knitting Club meet on the third Wednesday of each month from 7.30 to 9.30 p.m. at Devonshire Rooms, Waghorn Road, Snodland, Kent. Contact: Mrs. Mary Hawkes, 29 Lee Road, Snodland, Kent. Tel: 0634 242641.

**SWANLEY** - Five Wents Machine Knitting Club meet on the last Tuesday of the month from 7.30 p.m. at Memorial Hall, Hextable. Contact: Mrs. Betty Smith, 17 St. David Road, Hextable, Swanley, Kent BR8 7RJ. Tel: 0322 62657.

**SWANLEY** - Whiteoak Machine Knitting Club meet third Tuesday of every month from 1.30p.m. to 3.30p.m. at Youth and Family Centre Hall, Kingswood Ave., Swanley, Kent BR8 7JW. Contact: Mrs. E. Snelling, 64 Lullington Ave., Swanley, Kent. BR8 75W. Tel: 0322 63012.

**TUNBRIDGE WELLS** - Tunbridge Wells Machine Knitting Club meets first Monday of each month from 7.30 - 10.00 p.m. at the United Reform Church Hall, Hawkenbury, Tunbridge Wells, Kent. Contact: Mrs A. Morson, 6 Rookley Close, Bayhall Road, Tunbridge Wells, Kent. Tel: 0892 21472.

## SURREY

**GUILDFORD** - Machine Knitting Classes are held at Guildford Adult Education Institute. Contact: Carolyn Goulter, 4 Ashenden Road, Guildford, Surrey, GU2 5UU.

**GUILDFORD** - Machine Knitting Club meets third Monday of each month from 8p.m. at Salvation Army Hall, Leas Road, Guildford, Surrey. Contact: Mary Strath, 17a Saffron Platt, Guildford, Surrey. Tel: 0483 234262.

**HORLEY** - Horley Machine Knitting Club meets first Friday of every month at Horley Adult Education Centre, Court Lodge, Horley. Contact: L. Aylwin, 64 Ridgeway Road, Redhill. Tel: 0737 764924.

**WOKING** - The Woking Machine Knitting Club meets on the second Tuesday of every month from 8 p.m. at St Paul's Church Hall, Oriental Road, Woking. Contact: Mrs Doreen Throssell, 27 Gorsewood Road, St John's, Woking. Tel: 04867 3533.

## EAST AND WEST SUSSEX

**CROWBOROUGH** - The Ashdown Forest Machine Knitting Club meet on the first Thursday of each month from 7.30 p.m. at St. Michael's Church Hall, Jarvis Brook, Crowborough, East Sussex. Contact: Mrs. Maureen Carr, Firbury, South View Road, Crowborough, Sussex. Tel: 0892 661056.

**EAST GRINSTEAD** - The East Grinstead Machine Knitting Club meet on the third Monday of each month from 7.30 to 9.30 at the Small Parish Hall, Delawar Road, East Grinstead, Sussex. Contact: Marion Hall, 27 Crescent Road, East Grinstead, Sussex RH19 9HR. Tel: 0342 327698.

**HORSHAM** - Horsham M/c Knitting Club meet third Tuesday in every month at 7.30 p.m. at Bryce Lodge, New Street, Horsham. Contact: Mrs Lyn Levin, 52 Kempshot Road, Horsham. Tel: 0403 57397.

**MIDHURST** - Various Machine Knitting Classes are held at Midhurst Adult Education Centre. Contact: Janice Newton, 16 Poplar Way, Midhurst, West Sussex GU29 9JQ. Tel: 0730 816786.

**WORTHING** - Worthing Machine Knitting Club meet on the third Wednesday of the month from 7.30 p.m. at New Road Church Hall, Dunnington. Contact: Elspeth Bunker, 122 Shandon Road, Worthing, East Sussex. Tel: 0903 2036626. Or, Dawn Latter, 6 Winterton Way, Shoreham by Sea, East Sussex. Tel: 0273 464821.



## HAMPSHIRE, DORSET AND ISLE OF WIGHT

**ALTON** - The Alton Machine Knitting Club meet on the fourth Wednesday of each month from 8p.m. to 10p.m. at All Saints Church Hall, Queens Road, Alton. Contact: Mrs. O. Turrall, 10 Crowley Drive, Alton, Hants. GU34 2SG. Tel: 0420 85300.

**BOURNEMOUTH** - Kingfisher Knitting Club meets every alternate Tuesday from 2p.m. to 4p.m. at Muscliff Community Association Centre, Shillington Drive, Muscliff, Bournemouth, Dorset. Contact: Mrs Shirley Mitchelmore, Tel: 0202 573337. or Mrs Georgie Sweet, Tel: 0202 474786.

**FLEET** - Fleet Machine Knitting Club meets on the first Tuesday of each month from 8p.m. at St. John's Ambulance Hall, Clarence Road, Fleet. Contact: Mrs. N. Cornwell, 11 the Oaks, Fleet, Hants. GU13 8HQ. Tel: 0252 613186.

**PORTSMOUTH** - Denmead Machine Knitting Group meets on the first Tuesday of

each month from 8.00 p.m. at the Annexe of the Denmead Community Centre, School Lane, Denmead, Portsmouth. Contact Clare Dimmer (Secretary) Tel: 0705 261208 or Sue Lanham (Organiser) Tel: 0705 255544.

**PORTSMOUTH** - Swiftknitters Machine Knitting Club meet on the first and third Thursday of each month (excluding August) from 7.00 to 9.00 p.m. at Swiftknitters, 131/133 Fratton Road, Portsmouth, Hants. PO1 5ES. Contact: Peter Walsh or Ellen Prince at the above address. Tel: 0705 820281.

**SHERBORNE** - Sherborne and District Machine Knitters Club meets on the second and fourth Thursdays of every month from September to May from 7.45p.m. at The Day Centre, Digwy Road, Sherborne. Contact: Mrs Joy Coffin, Greenhill Farm, Thornford, Sherborne, Dorset. Tel: 0935 872351.

**WAREHAM** - Wareham Machine Knitting club meet on the second Monday of each month. Upstairs at the Reference Room, Wareham Library, South Street, Wareham. Contact: Olive Kent, 109 Wessex Oval, Wareham, Dorset BH20 4BS. Tel: 0929 553394.

**WAREHAM** - Winfrith Knitting Club meet on the first Wednesday of each month from 8.00 to 10.00 p.m. at Newburge Village Hall. Contact: Angela Gordon, 29 St. Helens Road, Sandford, Wareham, Dorset. BH20 7AX. Tel: 0929 551073.

## CORNWALL, DEVON, SOMERSET, AVON, WILTSHIRE, AND ISLES OF SCILLY

**BATH** - Bath Knit Wits meet every second Tuesday of each month from 7.30 p.m. at Hillside Community Hall, Hillside Road, Moorlands, Bath. Contact: Gill and Tom Willis, Sew Will Knit, 45 Brougham Hayes, Bath BA2 3QU. Tel: 0225 337290.

**BODMIN** - Bodmin Machine Knitting Club meet fourth Wednesday in every month 2p.m. to 4.30p.m. at Lanhydrock Village Hall, Trebyan, Nr Bodmin. Contact: Tim Cox, Owlswood Oldmill, Callington, Cornwall. Tel: 0579 70714.

**BRISTOL** - Patchway Machine Knitting Club meet on the fourth Wednesday of each month from 7.30 to 9.30 p.m. at St. Chad's Church Hall, Patchway, Bristol. Contact: Mrs. M. B. Crane, 61 Durband Road, Patchway, Bristol, BS12 5HG. Tel: 0272 692829.

**BRISTOL** - The Big Knits meet on the third Thursday of every month from 7.30 p.m. at Hanham Folk Centre, Hanham, Bristol. Contact: Mrs. Joyce J Cooper, 41 Marion Road, Hanham Bristol. Tel: 0272 679135.

**BRIXHAM** - Brixham Machine Knitting Club meets every alternate Tuesday from 7.30p.m. at the Seaman's Mission, Overgang Road, Brixham. Contact: Gillian Baker, 6 Valletort Park, Brixham, Devon TQ5 8PW.



**CAMELFORD** - Camelford Machine Knitting Club meet every five or six weeks at Member's homes from 8 p.m. Contact Miss P. E. Davis, Grylls Rose, Slaughterbridge, Camelford, Cornwall, PL32 9TT. Tel: 0840 213477.

**IVYBRIDGE** - Ugborough Hand & M/c Knit Club meet last Thursday in every month at 7.30 in the Ugborough Village Hall. Contact: Ros Romanel, 10 Lutterburn St, Ugborough, Ivybridge, Devon. Tel: 0752 893858. or Dot on 0752 892602.

**KINGSBRIDGE** - Kingsbridge Machine Knitting Club meet on the first Tuesday of the month from 7.30p.m. at Member's houses. Contact: Deb Hucker, Inner Glebe, Tithe Hill, Churchstow, Kingsbridge, South Devon. Tel: 0548 85 2951.

**LAUNCESTON** - Launceston Knitting Club meet first Wednesday in every month 7.30p.m. to 10p.m. at St. Thomas Church Hall, Kensey Vale, Launceston, Cornwall. Contact: Doreen Morgan, Andorey, Lifton Down, Launceston. Tel: 0566 84221.

**LISKEARD** - Liskeard Knitting Club meet second Wednesday in every month 7p.m. to 9.30p.m. at Manley Close Community Centre, off Manley Road, Liskeard, Cornwall. Contact: Betty Rowe, 3 Crabtree Close, Lanchard, Liskeard. Tel: 0579 43391.

**LISKEARD** - Adult Education Machine Knitting Classes are held every Thursday 1.30p.m. to 3.30p.m. at Callington Community School. Contact: Adult Education Office, Liskeard, Cornwall. Tel: 0579 45384.

**NEWQUAY** - Newquay Knitting Club meet second Tuesday every month from 2 p.m. to 4.30 p.m. at 6 St Thomas Road, Newquay, Cornwall. Contact: Ann Johnson at the above address. Tel: 0637 877440.

**NEWTON ABBOT** - Teign Machine Knitting Club meet on the second and fourth Friday of each month from 7.00 p.m. at The Community Centre, Newton Abbot. Contact: Mrs Yvonne Abbot, 12 Wolverton Drive, Kingsteignton, Newton Abbot, South Devon, TQ123EY. Tel: 0626 53739.

**NEWTON ABBOT** - Dartmoor Knitters Club meet fourth Thursday in every month 7.30p.m. to 10p.m. at the Village Hall, Ilsington, Nr Newton Abbot. Contact: Christine Lamb, Corran Ilsington, Newton Abbot, Devon. Tel: 03646 425.

**PLYMOUTH** - Crownhill Knitting Club meet first Wednesday in every month 2p.m. to 4.30p.m. at the Methodist Church Hall, Crownhill Plymouth. Contact: Tim Cox, Owls Wood, Old Mill, Callington, Cornwall. Tel: 0579 70714.

**PLYMOUTH** - Plym Knitters Club meet second Tuesday in every month 7p.m. to 10p.m. at Elburton Village Hall, Springfield Road, Plymouth. Contact: Tim Cox, Owls Wood, Old Mill, Callington, Cornwall. Tel: 0579 70714.



**ST. IVES** - The Bay Knitwits meet every Wednesday from 7.30 p.m. at Little Gonwin, Porthrepta Road., Carbis Bay, St. Ives. Contact: Mrs. Cynthia Fairburn at the above address. Tel: 0736 795079.

**STREET** - Classes are held for Beginners, Intermediate and Advanced on Mondays from 11.00 a.m. to 1.00 p.m. and 7.00 p.m. to 9.00 p.m. Ribber work on Thursdays from 7.00 to 9.00 p.m. at Strode College, Strode Road, Street. Contact: Valerie Firth, The Cottage, Peak Lane, Compton Dundon, Somerton, Somerset. TA11 6PE. Tel: 0458 72151.

**SWINDON** - The White Horse Machine Knitting Club meet on the second and fourth Thursday of each month at The Community Centre, Railway Village, Emlyn Square. Contact: Mrs. Dawn Lawrence, 14 Shrewton Walk, Penhill, Swindon, Wilts, SN2 5LZ. Tel: 0593 725703.

**TAUNTON** - Taunton Machine Knitting Club meets first and third Tuesday of every month from 7.30p.m. at The Adult School, Harcourt Street, Taunton, Somerset. Contact: Mrs Gwen Tromans, 23 Bloomfield Close, Taunton. Tel: 0823 333564.

**TORPOINT** - Torpoint Knitting Club meet second and fourth Mondays in every month 7p.m. to 9.30p.m. at Council Chambers, York Road, Torpoint, Cornwall. Contact: Carole Tope, 120 Antony Road, Torpoint. Tel: 0752 813738.

### **GLOUSTERSHIRE, HEREFORD & WORCESTER AND SHROPSHIRE**

**CHELTENHAM** - Cotswold Machine Knitting Club meet third Friday in every month at St Marks Community Centre, Brooklyn Road, Cheltenham. Contact: Mrs Hilda Hope, 4 Brooklyn Close, Cheltenham. Tel: 0242 529038.

**CIRENCESTER** - Cirencester Machine Knitting Club meets first Tuesday of every month from 7.30p.m. in the Jig Saw Room at The Pop Inn, Akerman Court, Cirencester.

Contact: Beryl Clarke, 8 Suffolk Place, Doun Ampney, Cirencester. Tel: 0793 750215.

**LUDLOW** - The Ludlow Machine Knitting Club meet every second Thursday of each month from 7.30 to 9.30 p.m. at The Further Education Centre, Bromfiled Road, Ludlow. Contact: Gloria Thomas, The Cat's Wiskers, 72 Lower Broad Street, Ludlow, Shropshire, SY8 1PH. Tel: 0584 876038 (Shop) or 0584 872207 (Home).

**LUDLOW** - Machine Knitting Classes are held on Mondays from 7.30 to 9.30 at The Further Education Centre, Bromfiled Road, Ludlow. Contact: Gloria Thomas, The Cat's Wiskers, 72 Lower Broad Street, Ludlow, Shropshire, SY8 1PH. Tel: 0584 876038.

**SHREWSBURY** - Nutty Knitters Knitting M/C Club meets every alternate Thursday 7.30p.m. in small meeting room at Radio Shropshire, Boscobel Drive, Heath Farm, Shrewsbury, Shropshire. Tel: 0743 50216.

**SHREWSBURY** - The Shrewsbury and District Machine Knitting Club meet every other Wednesday from 2.15 p.m. at The Bayston Hill Methodist Church Hall, Lansdowne Road, Bayston Hill, Shrewsbury. Contact: Mrs. M. Eileen Leath, 12 Honeysuckle row, Sutton Park, Shrewsbury, SY3 7TW. Tel: 0743 61220.

**WEM** - Wem Machine Knitting Club meet one Wednesday a month from 8.00 to 10.00 p.m. at The Scout and Guide Hut, Bowens Field. Contact: Yvonne. Tel: 0939 33690.

### **OXFORDSHIRE, BERKSHIRE, BUCKINGHAMSHIRE AND BEDFORDSHIRE**

**AMERSHAM** - Chiltern Machine Knitting Club meets third Wednesday of every month from 7.45p.m. to 10.15p.m. at Amersham Common Hall, White Lion Road, Amersham, Bucks. Contact: Claudie Cameron-Wilson, Tel: 0895 833920.

**AMPTHILL** - Ampthill Knitting Club meets every alternate Tuesdays from 8p.m. at Redbourne School, Ampthill, Bedfordshire. Contact: Mrs Colvin, 22 Dew-Pond Road, Flitwick, Bedfordshire. Tel: 0525 716494.

**BEDFORD** - Evening classes for Machine Knitting will be available at The Mark Rutherford Community College, Wentworth Drive, Bedford MK41 8PX. Enrolment commencing September. Contact: Mr M. Knight at the above address. Tel: 0234 58299.

**CARTERTON** - Carterton Machine Knitting Club meet on alternate Wednesdays from 7.30 p.m. at 4 Butlers Drive, Carterton, Oxon, OX8 3QN. Contact: Margaret (Peggy) Linfield at the above address. Tel: 0993 841778.

**GREAT MISSENDEN** - Residential and non residential courses will be held from 29th July to 25th August 1990 at Missenden Abbey, Great Missenden, Bucks. Contact: Missenden Summer School, at the above address. Tel:



0494 890295. for further information and bookings.

**MINSTER LOVELL** - Windrush Machine Knitting Club meet on the second and fourth Mondays of each month from 7.15 to 9.30 p.m. at Witney Mills Sports Pavilion. Contact Mrs. Christine Busby, 42 Brize Norton Road, Minster Lovell, Oxon. Tel: 0993 775706.

### **ESSEX, CAMBRIDGESHIRE, SUFFOLK, NORFOLK AND LINCOLNSHIRE**

**BASILDON** - Machine Knitting Classes are held on Mondays from 2p.m. to 4p.m. at the Laindon Community Centre. Contact Vera Monger, 29 Amersham Avenue, West View Park, Laindon, Basildon, Essex SS16 6SJ.

**BOSTON** - The Boston Machine Knitting Club meet on Wednesday mornings at The Boston Machine Knitting School. The School hold various Workshops on Sunday mornings or on the second Thursday of each month from 7.30 - 9.30 p.m. at Boston Machine Knitting School, 81 High Street, Boston, Lincs. Contact: Anne at the above address. Tel: 0205 356778 (Day) or 0205 65974 (Night)

**CHELMSFORD** - South Woodham Machine Knitting Club meet on alternate Fridays (except school holidays) from 1.00 to 3.00 p.m. at The Games Room, Village Hall, South Woodham Ferrers. Contact: Jennifer Brunning, 27 Redshank Crescent, South Woodham Ferrers, Chelmsford, Essex CM34SF. Tel: 0245 322282.

**COGGESHALL** - Machine Knitting Classes are available during term time every Wednesday from 1.30 to 3p.m. (creche available) and 7.30 to 9p.m. at Honywood Community School, Westfield Drive, Coggeshall, Essex. Contact: Sheila Cross, Brick Kiln Farm, Gt. Tey, Essex CO6 1AR. Tel: 0787 223356.

**HARLOW** - The Latton Bush Machine Knitting Club meet every Wednesday from 8 p.m. to 10 p.m. at Latton Bush Centre, Southern Way, Harlow, Essex. Contact: Mrs. Rose Bowyer, 63 Chapel Field, Harlow Essex, OM17 9EH. Tel: 0279 29817.

**HOLLAND-ON-SEA** - Clacton Machine Knitting Club meet on alternate Mondays from 7.00 p.m. at Holland Public Hall, Frinton Road, Holland-on-sea. Contact: Mrs. Rene Rollison. Tel: 0255 473014.

**HORNCHURCH** - Adult Machine Knitting classes are held every Wednesday from 10a.m. to 12.00 or 2p.m. to 3.45p.m. (during term time) at Ardleigh House, Ardleigh Green Road, Hornchurch, Essex. Contact: Mrs N. E. Cecil or the Principal at the above address. Tel: 04024 74170.

**ILFORD** - Parkside Machine knitting Club meet every Thursday, from 7.30 p.m. to 9.30 p.m. at Parkside Community Centre, Goodmayes Lane, Goodmayes, Ilford, Essex.

Contact Mrs. Joyce Gale. Tel: 0708 49984 or Mrs. M. Morley. Tel: 01 599 0219.

**IPSWICH** - Kesgrave Knatty Knitters Club meets on the first Wednesday of each month from 7.15p.m. at New Village Hall, Bell Lane, Kesgrave. Contact: Mrs Olive Procyshyn, 35 Edmonton Road, Kesgrave, Ipswich IP5 7EG. Tel: 0473 622086.

**PETERBOROUGH** - Various adult machine knitting classes are held at Brook Street and District Adult Education College, Peterborough. Contact: Rita Skeels, 6 Addinton Way, Werrington Peterborough PE4 6RR. Tel 0733 76510.

**ROCHFORD** - In Sitches M/c Knitting Club meets second Monday and last Thursday of each month at 8p.m. at 236 Ashington Road, Rochford, Essex. Contact: Mrs Derry Ffitch at the above address. Tel: 0702 546877.

**SOUTHEND-ON-SEA** - Knit Linkers Machine Knitting Club meets on the first Friday of each month from 8p.m. at the Labour Hall, Cambridge Road, Southend-on-Sea. Contact: Glad Parkinson, 53 Central Ave., Southend-on-Sea, Essex SS2 5HR.

**ST. NEOTS** - The St. Neots Machine Knitting Club meet on the last Monday of each month (except August) from 7.30 to 9.30 p.m. at Priory Centre, St. Neots. Contact: Mrs. Daphne Fuller, 30 Wordsworth Ave., Eaton Ford, St. Neots, Cambs. Tel: (Home) 0480 214393 (Priory Centre Office) 0480 213934.

**STANSTED** - The Stansted Mountfitchet Machine Knitting Club meet on the first and third Thursday of each month from 8 p.m. in Member's homes. Contact: Mrs. A. Richardson, 11 Longcroft, Stansted, Essex. CM24 8JD. Tel: 0279 813953.

**SUDBURY** - Gt. Cornard Machine Knitting Classes meet every Tuesday (during term time) from 7.30 to 9.30p.m. at Great Cornard Upper School, Head Lane, Gt. Cornard, Sudbury Suffolk. Contact: Sheila Cross, Brick Kiln Farm, Gt. Tey, Essex CO6 1AR. Tel: 0787 223356.

**WYMONDHAM** - Wymondham Machine Knitting Club meet on the second Tuesday of every month (except August) at 144 Tuttle Lane West, Wymandam, Norfolk NR18 0JJ. Contact: Mrs. Linda Dewhurst at the above address.

### **NORTHAMPTONSHIRE, WARWICKSHIRE, WEST MIDLANDS, AND LEICESTERSHIRE**

**BIRMINGHAM** - Mirfield Centre M/c Knit Class meet every Monday at 1p.m. to 3p.m. at the Mirfield Centre, Yockleton Road, Lea Village, Birmingham 33. Also Smithwood School M/c Knit Class on Tuesdays at 7.15 p.m. to 9.15 p.m. (term time) at Smithwood School, Windward Way, Chelmsley Wood, Solihull. Contact: Joan Buckle, 57 Greyfort Crescent, Solihull. Tel: 021 706 7185.

**BIRMINGHAM** - V. J.'s Knitting Club meet on the first Thursday each month from 7.30 to 9.00 p.m. at Bartley Green, F. C. Jiggins Lane, Bartley Green. B32 3H5. Contact: Mrs. V. Haynes, To and Fro House, 294 Jiggins Lane, Bartley Green, Birmingham, B32 3HJ. Tel: 021 426 1789, or Jane Lensay Tel: 021 550 9550.

**COVENTRY** - Swiftmits Machine Knitting Club meets second Monday of every month at 7.15p.m. to 9.15p.m. at Stoke Park Community Centre, Dane Road, Stoke, Coventry. Contact: Mrs D Heaton, 50 William McKee Close, Binley, Coventry.

**DUDLEY** - Bonnies Wools Knitting Club meet on the third Thursday of each month at Bonnies Wools, Wellington Road, Dudley, West Midlands. Contact: Mrs. V. Haynes, To and Fro House, 294 Jiggins Lane, Bartley Green, Birmingham, B32 3HJ. Tel: 021 550 9550.

**GREAT BRIDGE** - Barbara's Knit Inn Machine Knitting Club meet on the first Wednesday of each month from 7.00 to 9.00 p.m. at Barbara's Knit Inn, 23a Market Place, Great Bridge, West Midlands DY4 7EL. Contact: Mrs. B. Duffill at the above address. Tel: 021 520 6963.

**NORTHAMPTON** - Monday Machine Knitting Club meets on the the 3rd Monday of the Month at Friends Meeting House, Wellington Street, Northampton. Contact: Joyce Scales, 69 High Street, Collingtree, Northants. Tel: 0604 762691.

**NUNEATON** - Whitestone Machine Knitting Club meet on alternate Mondays from 1.30 to 3.30 p.m. at Whitestone Community Centre, Magyar Crescent - Whitestone, Nuneaton, Warks. Contact: Reph Gibbens. Tel: 0203 349841.

**WALSALL** - Aldridge Machine Knitting Club meet on the first and third Thursday of each month from 7.30 p.m. at The Aldridge Community Centre, Leighswood Road, Aldridge, Walsall, West Midlands. Contact: Audry Penn, 6 Middlemore Lane West, Aldridge, Walsall, West Midlands. Tel: 0922 52737.

**WARLEY** - Allsew-Knit Knitting Club meets first and third Fridays every month from 7.30p.m. at Allsew-Knit, 9 Halesowen Street, Rowley Regis, Warley, West Midlands. Contact: John White at the above address. Tel: 021 5593272.

### **STAFFORDSHIRE, DERBYSHIRE, NOTTINGHAMSHIRE AND HUMBERSIDE**

**ANLABY** - The Yarn Break Machine Knitting Club meet on the first Tuesday of each month from 7.30 - 9.30 at St. Peters Church Hall, Hull Road, Anlaby, N. Humberside. Contact: Joan Friston 65 Bedford Road, Hessle, N. Humberside HU13 9DG. Tel: 0482 646904.





Kathleen Humphries or Sylvia Smith, 16 Medway Close, Stocks Park, Horwich, Bolton. Tel: 0204 691437.

**KNOWSLEY** - Knowsley Machine Knitting Club meets every other Tuesday from 2.00 p.m. to 4 p.m. and Thursday from 7.30 p.m. to 9.00 p.m. at Knowsley Civic Hall, School Lane, Knowsley, Merseyside. Contact: Marilyn Duggan, "Arrochar", 14 Ash Gove, Rainford, Merseyside, WA11 8DV. Tel: 074 488 5128.

**RUNCORN** - Runcorn Machine Knitting Club meets every Friday from 7.30 to 9.30 p.m. at Placefields Junior School, Badger Close, Placefields, Runcorn, Cheshire. Contact: Mrs A Owen, 15 Peckfield Close, Brookvale, Runcorn, Cheshire WA7 6BP. Tel: 0928 712415.

**SALFORD, MANCHESTER** - Claremont Knitters Knitting Club meet on the first and third Wednesday of the month from 7.30 at the King Street Methodist Church, Irlands o'th Heights, Salford. Contact: Mrs Margaret Maybury, 16 Longton Road, Salford M6 7AW. Tel: 061 736 6600.

**SOUTH WIRRAL** - The Wool 'n' Things Machine Knitting Club, meet on Monday evenings from 7.00 p.m. to 9.00 p.m. at Red Cross Room, Station Road, Little Sutton, South Wirral. Contact: Mrs. E. Gardner, 20 Moorland Road, Ellesmere Port, South Wirral, L66 1LH. Tel: 051 344 1048.

**SOUTHPORT** - Southport Machine Knitting Club meet on the first and third Tuesday of each month (September to April inclusive) and the first Tuesday of each month (May to August inclusive) from 7.00 p.m. to 9.00 p.m. at Connel Court, Weld Road, Southport. Contact: Mrs. E. Beecham, 24 Knob Hall Lane, Southport, Merseyside. Tel: 0704 211749.

**THORNTON CLEVELEYS** - Wyre Knitting Club meets on the second Thursday of every month from 7.30 p.m. at the Church Hall, Wignall Memorial Church, Victoria Road, Thornton Cleveleys, Lancs. Contact: Hazel Duignan, 21 Colesville Avenue, Thornton Cleveleys, Lancs FY5 4ND.

**WARRINGTON** - The Electro Knits Machine Knitting Club, who are a Club for electronic owners, meet on the first Tuesday of each month at Members' homes. Contact: Mrs. M. Ince, 153 Gainsborough Road, Warrington, WA4 6BW. Tel: 0925 39276.

### **YORKSHIRE, DURHAM, TYNE & WEAR, CLEVELAND AND NORTHUMBERLAND**

**BARNSELY** - The Trend Knitting Club meet every second Thursday from 7.00 p.m. at 298 Barnsley Road, Cudworth, Barnsley, South Yorks. Contact Mrs. M. Hooley at the above address. Tel: 0226 710480.

**FULFORDGATE, YORK** - "Know your Knitting Machine", Classes are held on

Wednesdays from 7.00 to 9.00 p.m. at Fulford School, Fulfordgate, York. Contact: Brenda Ellis, 32 Chestnut Grove, New Earswick, York YO3 8BU. Tel: 0904 762255.

**MIDDLESBROUGH** - Ormesby Day M/c Knitting Club meets every Wednesday at 2 p.m. at St Cuthberts Community Centre, Ormesby, Middlesbrough. Contact: Mrs M Turton or Mrs M Joyce, Tel: 0642 323707.

**NEW EARSWICK, YORK** - Advanced Machine Knitting Classes are held on Mondays from 9.30 to 11.30 a.m. and from 2.00 to 4.00 p.m. Contact: Brenda Ellis, 32 Chestnut Grove, New Earswick, York, YO3 8BU. Tel: 0904 762255.

**NEWCASTLE UPON TYNE** - Kenton Community Knitting Club meet on Tuesdays from 7.00 to 9.00 p.m. at Kenton Comprehensive School, Newcastle Upon Tyne, NE3 3QS. Contact: Community Tutor at the above address. Tel: 091 2869001.

**NEWCASTLE UPON TYNE** - The Knit Inn Machine Knitting Club meet on Mondays and Tuesdays from 2 p.m. to 3.30 p.m. and on Saturdays from 2.00 to 2.30 p.m. at The Knit Inn, 104 Westgate Road, Newcastle Upon Tyne, NE1 4AF. Contact: Mrs. Olive Birch at the above address. Tel: 091232 9149.

**NORTH SHIELDS** - Colour Coats Machine Knitting Club meet on alternate Tuesdays from 7.30 to 9.30 p.m. at 64 Malvern Road, Preston Grace, North Shields. Contact: Mrs. P. H. White, 22 Dilston Ave., Whitley Bay, Tyne & Wear, NE25 8Q6. Tel: 091 252 6543.

**POCKLINGTON, YORK** - Machine Knitting Classes are held on Thursday evening from 7.15 p.m. to 9.15 p.m. at Woldgate School. Contact: Brenda Ellis, 32 Chestnut Grove, New Earswick, York, YO3 8BU. Tel: 0904 762255.

**REDCAR** - The Cleveland Knitcraft Club meet every other Thursday from 7.00 p.m. to 9.00 p.m. at The Coatham Community Hall (at the back of the Health Centre) Redcar. Contact Mrs. K. Arthur. Tel: 0642 487458.

**YORK** - Know Your Knitting Machine club will meet every Thursday from September 7 p.m. to 9 p.m. at Oaklands School, York. Contact: Joan Calpin, 6 Saxon Place, Dodsworth Ave., York. Tel: 0904 424579.

**YORK** - The Viking Knitting Club meets first Thursday of every month 7 p.m. to 9 p.m. Pfaff/Passap - third Tuesday of every month 1 p.m. to 3 p.m. Brother Electronic - third Tuesday of every month 10.30 a.m. to 12 noon. Japanese machine workshop every Thursday 1 p.m. to 3 p.m. Contact: Joan Calpin, The Viking Loom, 22 High Petergate, YORK. Tel: 0904 620587.

## **SCOTLAND**

**ARBROATH** - Angus Machine Knitters Club meets every Thursday from 7 to 10 p.m. at the Y.M.C.A. Arbroath. Contact: Mrs Wendy

**BUXTON** - Buxton Quick Knits Machine Knitting Club, meet on the third Tuesday of alternate month from 8 p.m. at Westmount Carlisle Road, Buxton, Derbyshire. Contact: Sheila Morris, at the above address. Tel: 0298 71315.

**LOUGHBOROUGH** - Loughborough Machine Knitting Club meet on the second Tuesday of the month from 7.30 p.m. at John Storer House, Loughborough. Contact: Emily on 0533 374448.

**MOIRA - NR BURTON ON TRENT** - Knatty Knitters Club meet on the first Thursday of each month from 10.30 a.m. to 12.30 p.m. at Unusual Yarns, Rawdon Road, Moira, Burton-on-Trent, Staffs. Contact: Mrs. J. Sargent, 1 Rawdon Road, Moira, Nr. Burton on Trent, Staffs. Tel: 0283 212895. Or Mrs. Marjorie Culver, 33 Top Street, Appleby Magna, Nr. Burton on Trent, Staffs. Tel: 0530 71179.

**SCUNTHORPE** - The Close Knit Two Machine Knitting Club meet on the first Wednesday of each month from 7.30 p.m. at Polish Social Club, 216 Frodingham Road, Scunthorpe, South Humberside. Contact: Mrs. Cladys Dalton, 65 Fairfield Road, Scunthorpe, South Humberside. Tel: 0724 859533.

**WITHERNSEA** - Withernsea and District Knit Club meets third Monday in every month from 7.30 p.m. to 9.30 p.m. at Pavilion Leisure Centre, Withernsea, N Humberside. Contact: Mrs J. Dearing c/o Rosedene, Withernsea Road, Hollym, N Humberside. Tel: 0964 613926.

### **GREATER MANCHESTER, CHESHIRE, MERSEYSIDE, LANCASHIRE, CUMBRIA AND ISLE OF MAN**

**BIRKENHEAD** - Prenton Knitting Club meet on the first Tuesday of each Month from 7.30 p.m. at 26 St Stephens Road, Prenton, Birkenhead, L42 8PL. Contact: Mrs. Enid Kell at the above address. Tel: 051 6084264.

**HORWICH** - Horwich Machine Knit Club meets on the first Tuesday of each month from 7.30 to 9.30 p.m. at Rock St Pensioner's Hall, Rock St, Horwich, Bolton. Contact:



Gosling, 6 Linefield Road, Carnoustie, Angus District, Tayside. Tel: 0241 52898.

**AVIEMORE** - Alice Bowes Knitting Club meets every Monday from 7.30 p.m. at Hair at Unit Ten, Grampian road, Aviemore PH22, Scotland. Contact: Mrs. Amelia J. Nicolson, 7 Railway Terrace, Aviemore PH22, Scotland. Tel: 0479 811182.

**DUNDEE** - The Libby Knitters Club meet on Sundays from 7.00 to 10.00 p.m. at 47 Longhaugh Terrace, Dundee Scotland, DD4 9JN. Contact: Jean Imrie at the above address. Tel: 0382 507607.

**EARLSTON** - Earlston Machine Knitting Club meet on the first and third Mondays of each month from 1.45 to 3.45 p.m. at Community Lounge, Earlston High School, Earlston, Berwickshire. Contact: Mrs Mary Shenton, "Ruthview", Carolside, Earlston, Berwickshire, TD4 6AL. Tel: 089 684 628.

**GLASGOW** - Machine Knitting Classes are held every day and evening (exc Friday evening) at Cardonald College, 690 Mosspark Drive, Glasgow. Contact: Isobel Bain, Dept of Design and Technology at the above address. Tel: 041 8836151 Ext 286.

**GLASGOW** - Southside Knitting Club meets alternate Tuesdays from September to May at 1.30p.m. to 4p.m. and 7.30p.m. to 10p.m. at the Church Hall Millwood Street, Shawlands, Glasgow. Contact: Mrs P Divorty, 48 Meryvale Avenue, Giffnock, Glasgow. Tel: 041 6375976.

**HAWICK** - A varied and interesting selection of Classes are held at Borders College, Day and Evenings. Contact: Mr. Ronnie Hodgkins, Senior Lecturer Knitwear, Borders College, Henderson Building, Commercial Road, Hawick, Scotland. Tel: 0450 74191.

**KILMARNOCK** - Kilmaurs Machine Knitting Club meet every Tuesday from 7.30 - 9.30 p.m. at The Horsa Huts, Irvine Road, Kilmaurs. Contact: Mrs. M. Spence, 67 Auchencar Drive, Altonhill, Kilmarnock, Ayrshire, Scotland. Tel: 9563 23972.

**MUIRHEAD** - Ayr Machine Knitting Club meet on every second Tuesday from 7.30 to 9.30 p.m. at Kyle Academy, Ayr. Contact: Mrs. Marj. Wilson, 1 East Grove, Muirhead, Troon, Ayrshire. KA10 7BE.

**PERTH** - The Perth and District Machine Knitting Club meet on the last Tuesday of each month from 7.30 p.m. at The Waverley Hotel, York Place, Perth. Contact Mrs. E. Peddie, 41 Tweedsmuir Road, Perth PH1 2E2. Tel: 0738 34922.

## WALES

**BRIDGEND** - The Kenfit Knatty Knitters Club meet every Friday (when the children are in school) from 7.00 to 9.00 p.m. at Cynfig Comprehensive School, Kenfig Hill, Nr. Bridgend, Mid-Glam. Contact: Mrs. A. Bowden, 69 Bech Road, Pyle Nr Bridgend,



Mid-Glam. or Mrs. Jen Smith Tel: 0656 713241 or Mrs. B. Slough, 0656 740906.

**BRIDGEND** - The Bridgend and District Knitting Machine Club meet on the third Monday of each month from 7.00 p.m. at The Coity Higher Community Centre, Litchard, Bridgend, Mid Glamorgan. Contact: Mrs. Julie Powell, 157 Highfield, Bridgend, Mid Glamorgan. Tel: 0656 664265.

**DYFED** - Aeron Knitwits Machine Knitting Club meet on the third Thursday of each month from 9.30 a.m. to 3.30 p.m. at Bronaeron Sac, Felinfach, Lampeter, Dyfed, SA48 8AF. Contact: Olwen Edwards at the above address. Tel: 05704 70874, or home 05704 70859.

**GWENT** - Meets every Tuesday 7.15p.m. to 9.15p.m. at Caldicot Leisure Centre, Caldicot, Gwent, S. Wales. Contact: Mrs Jean Watkins, 32 Tennyson Road, Cladicot, Newport, Gwent. Tel: 0291 421277.

**KNIGHTON** - Knighton Machine Knitting Club meets second and fourth Tuesdays every month at 7.30p.m. at Hillsrest, Presteigne Road, Knighton, Powys. Contact: Cherie Hills at above address. Tel: 0547 528472. Carole Pygram, Chunters, Presteigne Road, Knighton. Tel: 0547 528406.

**PONTNEWYDD** - Comrades Machine Knitting Club meet every Monday from 7.00 p.m. to 9.30 p.m. at Pontnewydd Junior School, Bryne Celyn Road, Pontnewydd. Contact: Mrs. Jean Gaywood Tel: 04955 52638.

**SWANSEA** - The Knitmania Club meet every other Monday from 7.00 p.m. to 9.00 p.m. at The Vivian Hall, Blackpill, Swansea. Contact: Miss Elsie Lloyd, Copley Bishopston, Swansea. Tel: 044 128 4324.

## NORTHERN IRELAND

**HOLYWOOD** - The Guild of Machine Knitters of Northern Ireland meet on the fourth Saturday each month except December, June, July and August, from 11.00 a.m. to 3.30 p.m. at Manor House, Ulster Folk and Transport Museum, Cultra, Holywood, Co. Down. Contact: Meta McKeown, 5a Downview Park, Belfast, BT15 5HY. Tel: 0232 778864.

# Book Reviews

## PATTERN ON THE KNITTING MACHINE

by Ruth Lee, published by Batsford, Hardback £14.95. 191 pages.

The image shows the front cover of the book 'Pattern on the Knitting Machine' by Ruth Lee. The cover has a dark, textured background with a repeating pattern of small, light-colored motifs. In the center, there is a white rectangular box with a thin black border. Inside this box, the title 'P·A·T·T·E·R·N ON THE KNITTING MACHINE' is printed in a serif font, with the author's name 'RUTH LEE' below it. The dots in the title are small and spaced out.

The author has aimed at competent knitters who already have a basic knowledge of the main functions of their knitting machines, here is a working manual in patterned and decorative machine knitting which adopts a creative approach backed by a thorough exposition of method.

General introductory chapters on pattern, colour and yarns are followed by more detailed explanations of technique, concentrating on variations of a simple knit structure - in other words, stocking stitch and ribbing used to produce pattern rather than texture. Short row knitting, intarsia, single and double bed Jacquard and partial knit as a decorative technique are all covered, and methods of manipulating the surface of the knitting to produce decorative effects, - pleating, appliqué and stitched surfaces - are explained with an emphasis on simple structure and surface pattern.

Numerous examples offer a basis for further development and inspiration for the knitter to create new, original ideas. Helped by the author's characteristic enthusiasm, this book



will enable the machine knitter to create all the things she or he has considered making but lacked the confidence or know-how to try.

## MACHINE KNITTERS SUPER-TIPS PLUS

by *Angela N. Gordon* published by Compact Services. £7.45 (including postage and packing) 176 pages.

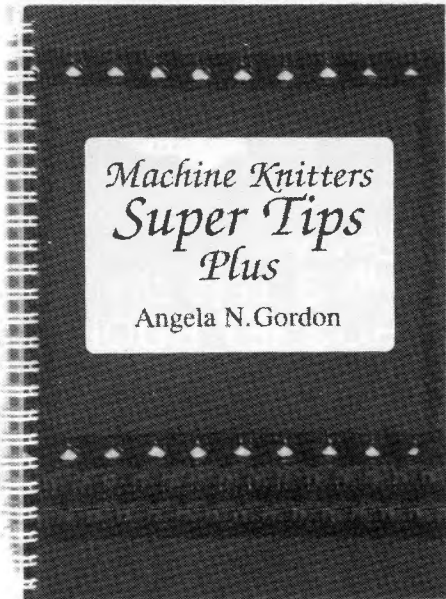

The hints and tips included in this book cover all Japanese standard gauge and chunky machines. Ribber techniques are covered in a

separate chapter, but are also in the chapters on neckbands, cardigan bands and skirts. A concise index can be found at the back enabling speedy solution to a specific problem. Angela chose to keep the spiral bound, A5 format because it had proved very popular with knitters as it is very convenient to use at the machine.

## DESIGNS FOR BEGINNERS

by *Jenny Rose* published by *Jenny Rose Designs*, spiral bound. £3.95. 50 pages.

Don't be misled by the title - this is just the book for every machine knitter who needs a useful collection of basic patterns to work from. **DESIGNS FOR BEGINNERS** features ten patterns, starting with a very simple sweater and progressing to a variety of garments which can be coordinated to produce complete outfits. With new machine knitters in mind all the patterns are written in an uncomplicated way and include helpful hints and tips to make them easy to understand. Standard abbreviations and new techniques are explained whenever they occur for the first time, and are also referenced in the index, though real beginners will need their instruction manual there as well to refer to from time to time. There are also two very useful pages of dos and don'ts.

The 10 basic designs include a baby top, slash neck sweaters, plain and striped, round neck and V-neck sweaters, striped-square sweater, cardigan, dress, skirt and a stylish tunic top.

## 4-ply magic

Ten mohair designs for standard gauge machines



*Jenny Rose*

## 4-PLY MAGIC

by *Jenny Rose*, published by *Jenny Rose Designs*, spiral bound, £3.95. 52 pages.

A collection of 10 new designs for standard gauge Japanese machines using the new 4-ply mohairs. These yarns lend themselves to such elegant everyday designs as a square neck lace sweater and a crossover cardigan. The book also features V-neck, fairisle and cable sweaters, a sideways-knitted cardigan and a cardigan with pockets. The designs may be knitted in most 4-ply yarns and are suitable for all 24-stitch punchcard machines - just three require a ribber.

## The Book of NATURAL YARNS 89-90

Shetland Wool  
2 ply & 4 ply m/w Wool  
2 ply & 4 ply Botany Wool  
Mercerised Cottons  
Slub Cotton  
Guernsey 5 ply Wool  
Lakes Cotton/Linen  
Fine Mohair  
British Wools  
3 ply Sock Wool  
Chunky Mohairs  
Aran Wool

NEW COLOURS FOR 1989-90



## The SUMMIT Collection

A wonderful collection of unique fancy yarns for standard gauge machines, plus 43 colours of top quality Summit 4 ply Acrylic

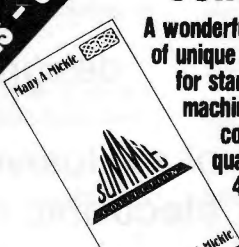

Send **£2.50** (refundable) for these two collections, plus the free Book of Basic Patterns, or phone to use your credit card.

We also sell Knitmaster and Brother machines, and Hague linkers by mail order.

**Many A Mickle**



Many A Mickle (Ref. B.F.), Brier Hey, Mytholmroyd, Hebden Bridge, W. Yorks., HX7 5PF. Tel: 0422 884749

# QUALITY KNITTING YARNS

## QUALITY MACHINE/HAND KNITTING YARNS.



MOHAIR



Pure new wool



LAMBSWOOL

BOTANY

MOHAIR

COTTON

Send **£1.50** for shade cards to: Brockwell Wools (Dept.MKF), Stansfield Mill, Triangle, Sowerby Bridge, West Yorkshire HX6 3LZ. Tel: (0422) 834343 or call at our shop.



Trade enquiries welcome.



**BROCKWELL WOOLS**



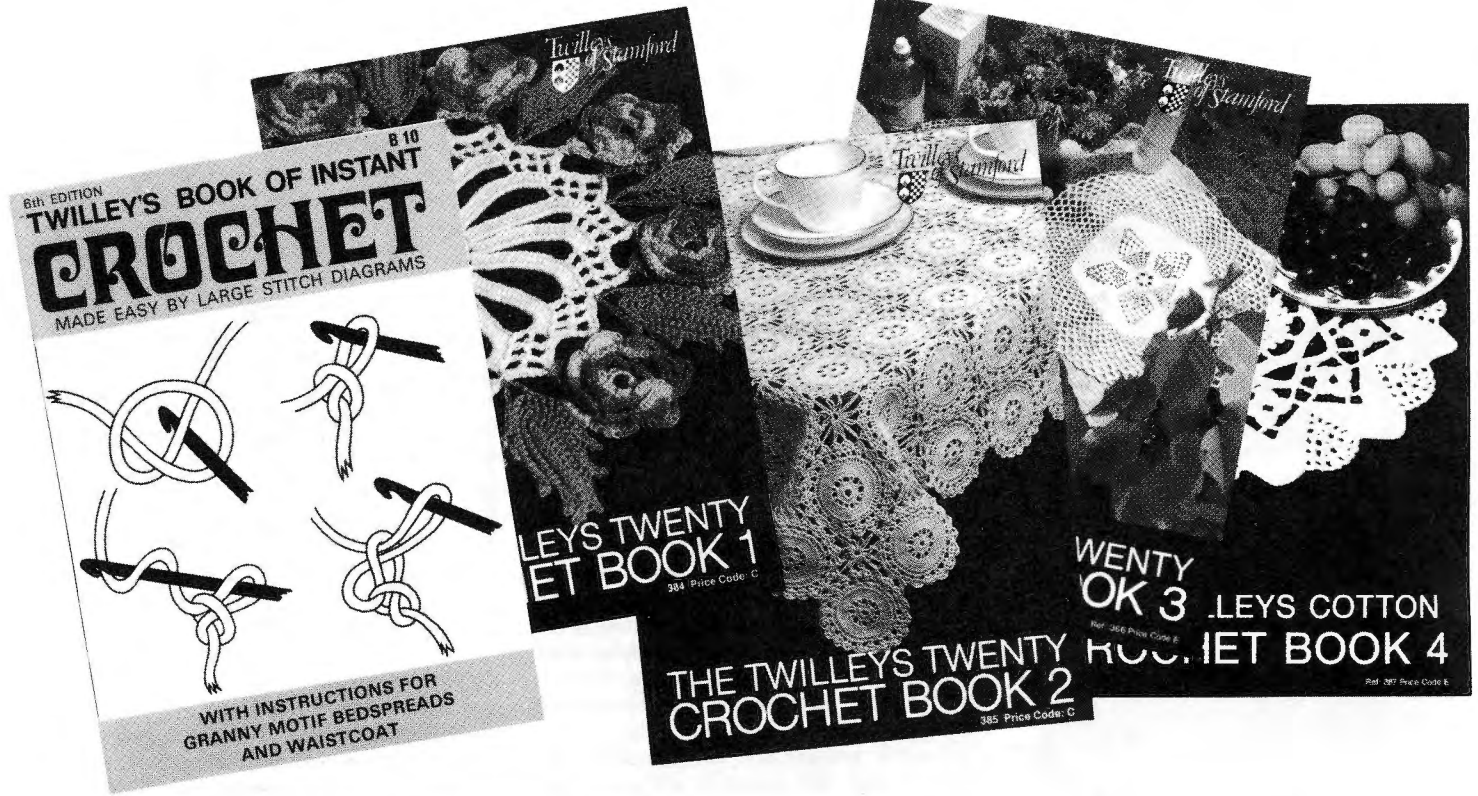

### CROCHET BOOKS FROM TWILLEYS

published by Twilleys, are available from Rena Wools, P.O. Box 23, Oakham, Leicester, LE156XJ - please send an A4 SAE (20p).

Crochet may be used on garments as a trim, collar, or even an integral part of the design, i.e. a whole garment piece may be in crochet. (See

our Step-by-Step Crochet and how we have used it for machine knitted garments). Twilley's have some superb books which will either start you off, or help you to extend your repertoire of crochet stitches. INSTANT CROCHET (40p) has excellent diagrams which will tell you all you need to know if you are a beginner, TWILLEYS TWENTY 1 and 2 (£1.55) and TWILLEYS TWENTY 3 at (£1.65) are all useful for household items and gifts - no garments.

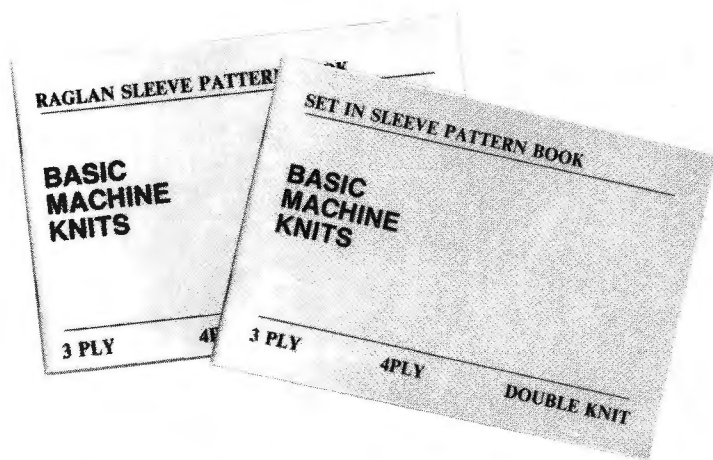

### MACHINE KNITTING BOOKS FROM AMBERYARN

published by Amberyarn and available from your local dealer or direct from them at Amberyarn, Dock Mills, Dockfield Terrace, Shipley, West Yorkshire, BD17 7AW. MACHINE KNITS FOR ALL THE FAMILY, DROP-SHOULDER STYLE SWEATERS, and RAGLAN DESIGNS are £2.99 + 30p postage and packing, BASIC MACHINE KNITS - RAGLAN SLEEVE BOOK and BASIC MACHINE KNITS - SET IN SLEEVE PATTERN BOOK are £2.25 + 30p postage and packing.

All the books are basic pattern books using various weights of yarn. MACHINE KNITS FOR ALL THE FAMILY - sizes 20 - 50 inch chest/bust in 3 ply, 4 ply and Double Knit. DROP-SHOULDER STYLE SWEATERS - sizes from 20 - 50 inch chest/bust in Aran, Chunky, Mohair and Brushed Chunky and Double Knit yarns. RAGLAN DESIGNS - sizes 20 - 50 inch chest/bust - in 3 ply and 4 ply. Both BASIC MACHINE KNITS are in sizes 20 - 44 inches in 3 ply, 4 ply and Double Knit

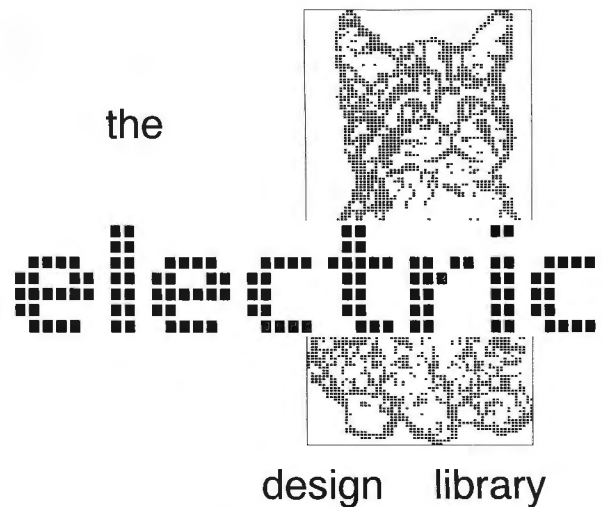

100's of exclusive designs for electronic owners

For details and sample by return, send an A4 SAE to

Foxwood Designs Ltd, Dept MKF, Stream House, Castle Hill, Rotherfield, East Sussex, TN6 3RU  
Tel: 082-585-388



# MAIL BOX

## TIPS FROM BRENDA

Brenda Ellis writes with some more tips to help you when knitting lace:

- 1 *Have weights evenly spread across the work.*
- 2 *Don't put weights too close to top of work, they need to be at least 2.5cm down.*
- 3 *Use Claw weights - not ribber weights, the ribber combs make good even weights so remove hanging weights and leave the comb in.*
- 4 *If the Lace Carriage feels "heavy" then it may be that too much weight is being used.*
- 5 *On Knitmaster, if ribber is attached to machine hang work over and in front of the ribber.*
- 6 *On Toyota have the bed flat on the table.*
- 7 *If stitches drop on the test piece or swatch, the yarn and the stitch are incompatible, either change the lace pattern or the yarn.*
- 8 *If a more solid edge is required - on neck edge or armholes - push back 2nd needle if it is selected.\**
- 9 *On Brother, Toyota, and Singer push back end needles when selected.\**
- 10 *Lace is usually better knitted 1 whole number tighter than main tension on stocking stitch.*
- 11 *Fine lace usually needs to be at least 1 whole number higher than main stocking stitch tension.\**
- 12 *Increase AFTER working lace, decrease BEFORE working lace.*

\*Does not apply to Knitmaster machines.

Many thanks Brenda I feel sure that these extra pointers will help everyone! Brenda runs various Classes - full details about her classes may be found in CLUBS AND CLASSES under FULFORDGATE, YORK.

## A QUESTION OF PATTERN

Mrs. I. G. Gregory from Warfield asks.....

*"I have just finished knitting the Cot Blanket featured in Issue 2 of Machine Knitting Fashion - photo page 28. I am very pleased with it - its a lovely idea. However I couldn't work out how to do the pink line around the edges of each square. I showed the pattern to members of Machine Knitting Class but nobody had any ideas. Would you be kind enough to explain it please."*

Thank you for your letter Mrs. Gregory, the pink "lines" you ask about are in fact chain stitch. It is possible to achieve a contrast line on the right side of the fabric by casting off on the right side of the fabric - see the bricks in the same pattern.

# DATES FOR YOUR DIARY

**9th and 10th June - TENSION, DESIGN, AND THE CHARTING DEVICE** - Machine Knitting Course taken by Hazel Pope, at The Manor House, Chiddingstone, Edenbridge, Kent TN8 7AH. Tel: 0892 870449

**23rd and 24th June - GET TO KNOW YOUR BROTHER ELECTRONIC** - Machine Knitting Courses taken by Gill Scholey, at The Manor House, Chiddingstone, Edenbridge, Kent TN8 7AH. Tel: 0892 870449.

**5th July, 1990 - FASHION SHOW** at Southlands Centre off Ormesby Road, Middlesbrough, Cleveland - a personal approach to machine knitting by Pat Phillpott who gives an insight into how her ideas evolve, how clothes relate to the body, how she uses the machines and, with colour and textures creates individuality with wearable clothes. Entrance £2.00. **Contact:** Mrs. M. Turton, 38 Balmoral Road, Ormesby, Middlesbrough, TS3 OND.

**7th July, 1990 - WORKSHOP** at Southlands Centre off Ormesby Road, Middlesbrough, Cleveland - for people taking City and Guilds Machine Knitting. From 9.30 a.m. to 4.30 p.m. the workshop is to help students understand the art and design section of the course. Pat Phillpott who will be taking the workshop will outline the principles and how they apply to knitting. There will be an opportunity for discussion and queries. Cost £11.00 for the day. **Contact:** Mrs. M. Turton, 38 Balmoral Road, Ormesby, Middlesbrough, TS3 OND.

**7th and 8th July - STITCHES TEXTURES AND DESIGN** - Machine Knitting Course taken by Hazel Pope, at The Manor House, Chiddingstone, Edenbridge, Kent TN8 7AH. Tel: 0892 870449

**8th July, 1990 - WORKSHOP** at Southlands Centre off Ormesby Road, Middlesbrough, Cleveland - for City and Guilds Machine Knitting Tutors. From 10.00 a.m. to 4.30 p.m. the workshop will help Tutors teach art and design - both knitting and design tutors are welcome. The workshop will cover:- 1) Understanding the role of basic design. 2) The 12 primary and the 12 secondary groups and the ways in which basic design develops. 3) How to help Students apply 1 and 2 to their knitting. Questions and answers welcome. Cost £11.00 for the day. **Contact:** Mrs. M. Turton, 38 Balmoral Road, Ormesby, Middlesbrough, TS3 OND.

**14th and 15th July, 1990 - GET GOING** - Machine Knitting Course taken by Hazel Pope, at The Manor House, Chiddingstone, Edenbridge, Kent TN8 7AH. Tel: 0892 870449

**21st and 22nd July, 1990 - STITCHES, TEXTURE AND DESIGN** - Machine Knitting Course taken by Hazel Pope, at The Manor House, Chiddingstone, Edenbridge, Kent TN8 7AH. Tel: 0892 870449

**4th and 5th August, 1990 - TENSION, DESIGN AND THE CHARTING DEVICE** - Machine Knitting Course taken by Hazel Pope, at The Manor House, Chiddingstone, Edenbridge, Kent TN8 7AH. Tel: 0892 870449



# NEWS ITEMS

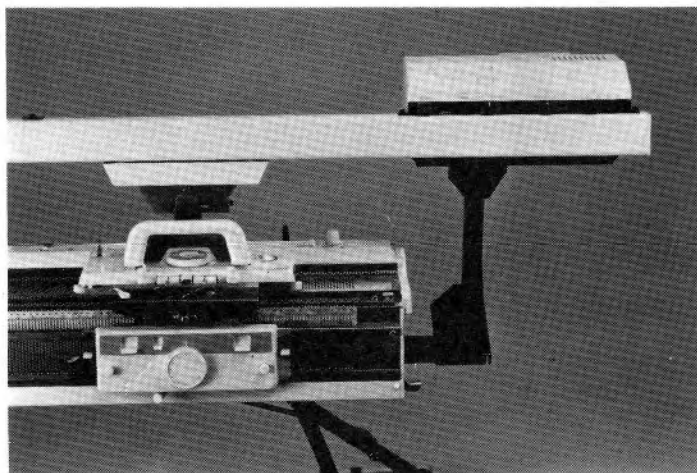

## KNITTING MACHINE MOTOR DRIVE UNIT KE-100 FROM BROTHER

- **EASY AND CONVENIENT** - Conveniently placed for ease of operation, the sophisticated control panel, which is the heart of the KE100 can operate the carriage automatically on continuous setting or row by row. Manual operation is also possible using the foot control provided.
- **BUILT-IN PRESET COUNTER** By presetting the row counter to a specific number the KE-100 will knit that quantity of rows and then stop.
- **FREE OPERATION RANGE** You can set the unit to operate over blocks of needles anywhere on the needle bed.
- **KNITTING SPEED CONTROL** Knitting Speed is selectable, either high or low, according to the fabric being produced.
- **YARN SENSOR, KNOT SENSOR** If the yarn breaks, runs out or becomes knotted, the motor will stop automatically, preventing dropped stitches.
- **DOUBLE SAFETY SYSTEM (OVERLOAD STOP MOTION)** The double safety system prevents possible damage to knitting machine or knitting.

The Brother KE-100 Super Drive may be used with the following Brother Knitting Machines:- Standard Gauge (4.5mm) Model Nos, KH910, KH940, KH950, KH950i, KH891, KH890, KH881, KH860, KH840, KH836, KH830, KH710; Chunky Knitter (9.0mm) Model Nos KH260, KH230; Fine Gauge (3.5mm) Model No KH120. For further information contact your Local Dealer or Knitting Machine Division, Jones+Brother, Shepley Street, Guide Bridge, Audenshaw, Manchester M34 5JD. Tel: 061 330 6531.

## KING COLE - GOOD IN SMALL AMOUNTS!

When knitting intarsia sweaters it can be rather annoying if the yarns you are working in can be found on cone only. King Cole have relaunched their famous 'ANTI-TICKLE' pure wool yarn available in double knitting and 4-ply, in 50g balls. there is a new design for the ballbands and these have all been printed on RE-CYCLED PAPER. The ballbands feature the slogan "wool runs on grass" which emphasises the fact that pure wool is the most environmentally friendly form of knitting yarn available. Local stockists will also be encourage to display "wool runs on grass" window stickers as a further promotion for all the pure wool yarns on the market. Both the D.K. and 4-ply in 50g balls are priced at £1.39. The new 50g balls are available in the same range of thirty-eight shades as the coned yarn.

## DESIGNED TO FIT AND EASY TO KNIT

Jacqui Fletcher from MACHINE KNITTING AND DESIGN CENTRE invites readers to sample their range of knitting patterns of the above title, they range from £1.50 to £3.00. Tel: 01 207 6557 for order form.

## DESIGNS ON DISC

The Stitch Pattern Sheets from Machine Knitting Fashion, past and present, will be available on disc in future - at the time of printing they are available to Subscribers at a cost of £3.00 for an Order Form drop a line to:- Machine Knitting Fashion, 5 Dryden Street, London, WC2E 9NW. Also available on disc is THE ELECTRONIC DESIGN STITCH LIBRARY - Contact Linda Black at Foxwood Designs, Stream House, Castle Hill, Rotherfield, E. Sussex TN6 3RU.

## MACHINE KNITTING FASHION - BACK ISSUES AVAILABLE!

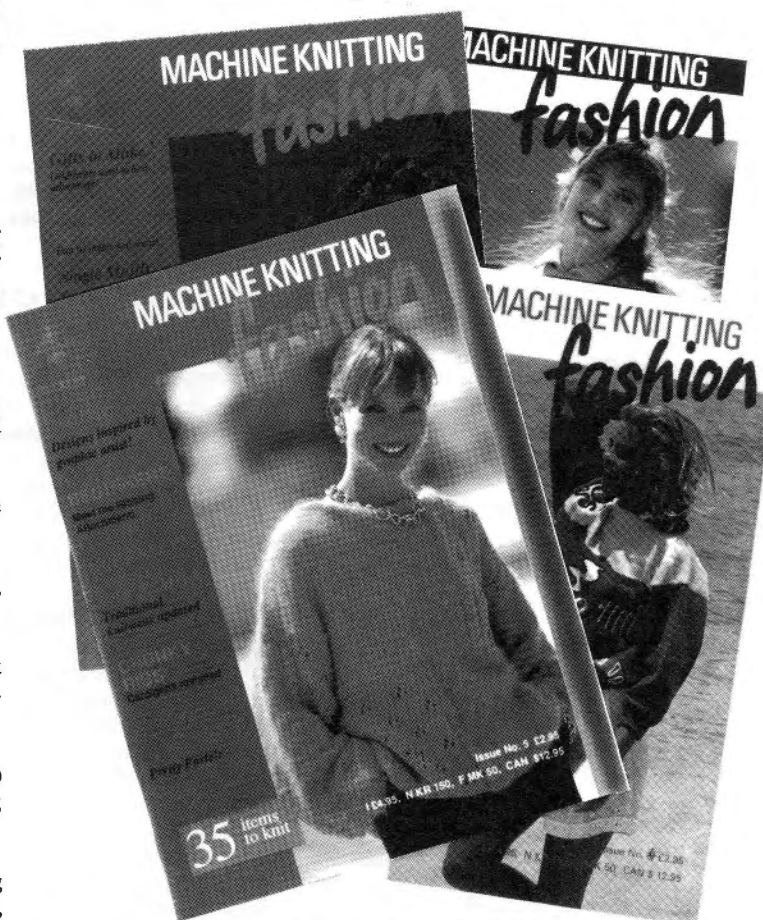

If you have just discovered the wonderful, the fabulous, Machine Knitting Fashion and would love to have back issues to complete your collection, send a cheque/postal order for £2.95 per book to:- Machine Knitting Fashion, 5 Dryden Street, London WC2E 9NW. (Cheques should be made payable to: "Jones+Brother".) Don't forget to state which Numbers you are itching to get your hands on!



6, 5, 6) sts x 1, 3 sts x 2, 2 sts x 2, then dec 1 st x 4. Knit to RC120 (132, 146, 162, 174) and waste knit rem 30 (32, 33, 36, 39) sts.

#### LEFT FRONT

As RIGHT FRONT reversing shapings.

#### NECKBAND

Join shoulders by placing both sets of shoulder sts onto Ns with right sides together. Using M T10 knit 1 row and cast off. Using A cast on over 99 KH Ns as RIB, 000. Knit to RC8. Trans all sts to KH T9 knit 1 row. With wrong side facing, pick up same number of sts evenly along neck edge and place onto Ns. T10 knit 1 row and cast off.

#### BUTTONHOLE BAND

Using A cast on over 97 (107, 119, 131, 141) KH Ns as RIB, 000. Knit to RC4. Work 7 x 2 st buttonholes evenly spaced along the row. Knit to RC8. Trans all sts to KH. T9 knit 1 row. With wrong side facing, pick up same number of sts evenly along RIGHT FRONT opening edge and place onto Ns. T10 knit 1 row and cast off.

#### BUTTON BAND

As BUTTONHOLE BAND omitting buttonholes.

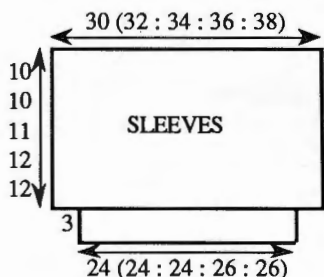

#### SLEEVES

Push 93 (100, 106, 112, 118) KH Ns into WP. With wrong side facing, pick up same number of sts evenly along armhole edge between WY markers and place onto Ns, 000. T9 working in Stripe Patt throughout knit to RC38 (38, 42, 46, 46) and waste knit. CUFFS: Push 75 (75, 75, 81, 81) KH Ns into WP. With wrong side facing, place sts from CUFF edge onto Ns distributing them evenly along the row. Using A T9 knit 1 row. Trans to RIB, 000. Knit to RC11. T10/8 knit 1 row. Trans all sts to KH and latch cast off.

#### MAKE-UP

Wash, block and press. Join side and SLEEVE seams. Attach buttons.

#### SKIRT (2 sections)

Using WY cast on over 145 (151, 157, 161, 169) KH Ns and knit a few rows, 000. Using A T8 knit to RC11. T10 knit 1 row, 000. T9 working in Stripe Patt throughout knit to RC12. Turn up hem and knit to RC104 (112, 120, 128, 136). WAISTBAND: Trans every alt st to adjacent N leaving empty Ns in NWP, 000. T5 knit to RC15. Bring all Ns to WP, T10 knit 1 row. Latch cast off dropping the loops formed on the empty Ns.

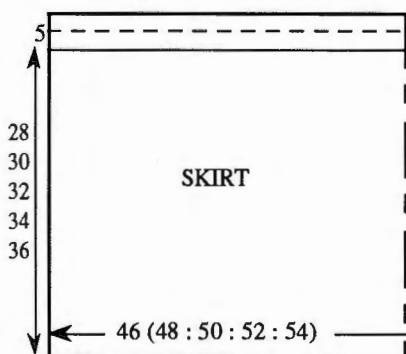

#### MAKE-UP

Wash, block and press. Join side seams. Fold WAISTBAND in half to inside and catch down loosely encasing elastic.

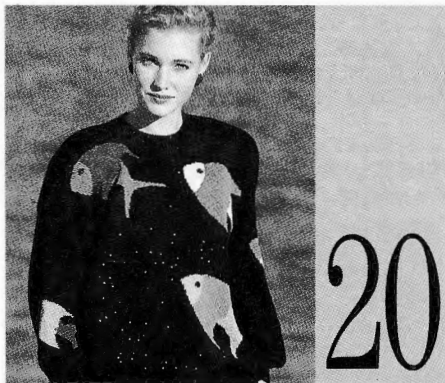

**MACHINES:** A, C or D with Intarsia facility or Intarsia Carriage with KL, and KR. **MATERIALS:** YEOMAN YARNS Cannele; M - 700 (720, 740, 760, 780)g (Black 30), small quantities in each of A - (Prairie 25), B - (Orient 16), C - (Turquoise 140), D - (Saffron 23), E - (Cardinal 27), F - (Sugar 36) (100% Cotton 350m/100g). Yellow and Red beads to decorate. **MEASUREMENTS:** To fit bust 86 (91, 96, 101, 106)cm. **TENSION:** St st/Intarsia (when making your tension swatch use Intarsia Carr if you intend to work the garment with the intarsia Carr - Intarsia Carr and K-Carr tensions can be very different) - 40 sts = 12.6cm and 60 rows = 14.3cm (approx T8) after washing, blocking and pressing. **RIB:** 1 x 1 T1/1. **NOTES:** See Stitch Pattern Sheet No 10(B) or (C).

#### PROCEDURE (See STEP-BY-STEP)

Make a tension swatch and set KL accordingly. Draw "Fishes" and garment diagram onto KL sheet. It is possible to use KL sheet to indicate the 'Fishes' and follow the garment instructions simultaneously.

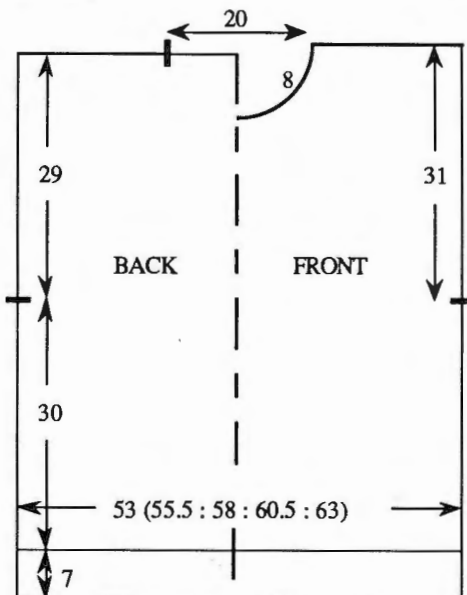

#### BACK

Using M cast on over 169 (177, 185, 193, 199) KH Ns as RIB, 000. Knit to RC36. Trans all sts to KH, 000. T8 working in st st/intarsia throughout knit to RC126. Place a WY marker at each end of work.\* Knit to RC248. Waste knit centre 63 sts. Waste knit rem 53 (57, 61, 65, 68) sts at each end of work for shoulders.

#### FRONT

As BACK to \*. Knit to RC222.

#### Neck shaping

Waste knit centre 23 sts. Waste knit sts at left, COR.

Knit 1 row. At beg of next and every foll alt row cast off 4 sts x 1, 3 sts x 2, 2 sts x 3, then dec 1 st x 4. Knit to RC256 and waste knit rem 53 (57, 61, 65, 68) sts. Return sts at left to Ns and knit to match right side reversing shapings.

#### NECKBAND

Join one shoulder by placing one set of shoulder sts back onto Ns with right sides together. Using M T10 knit 1 row and cast off. Push 153 KH Ns into WP. With right side facing, pick up same number of sts evenly along neck edge and place onto Ns. Using M T8 knit 1 row. Trans to RIB, 000. Knit to RC30. Trans all sts to KH. T8 knit 2 rows and waste knit. Join second shoulder as first. Join NECKBAND seam, fold in half to outside and backstitch to garment through last row knitted in M.

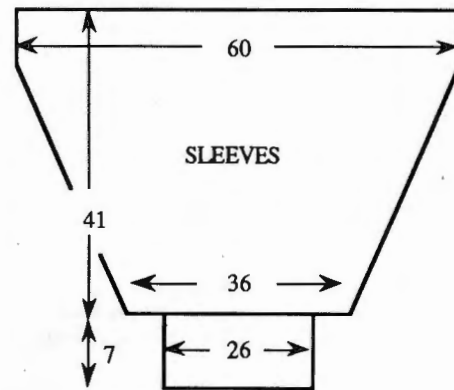

#### SLEEVES

Push 190 KH Ns into WP. With wrong side of garment facing pick up same number of sts evenly along armhole edge between WY markers and place onto Ns, 000. Using M T8 knit to RC20. Dec 1 st at each end of next and every foll 4th row x 38. Knit to RC172 and waste knit rem 114 sts. CUFFS: Push 83 KH Ns into WP. With wrong side facing, place sts from cuff edge onto Ns distributing them evenly along the row. Using M T8 knit 1 row. Trans to RIB, 000. Knit to RC35. T10/8 knit 1 row. Trans all sts to KH and latch cast off.

#### MAKE-UP

Wash, block and press. Join side and SLEEVE seams. Attach Beads as illustrated.

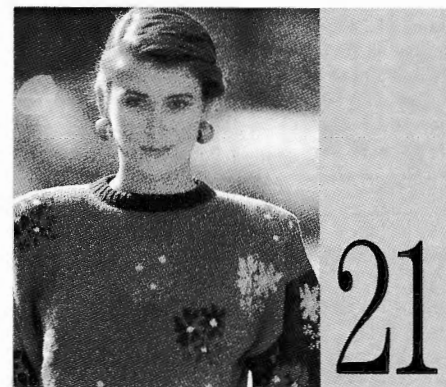

**MACHINES:** A, C or D and KR. **MATERIALS:** ATKINSON YARNS DESIGNER COLLECTION Wharfedale; M - 150(160, 170, 180, 190)g (Navy 019), A - 185 (200, 215, 230, 245)g (Lagoon 129), B - 80g (Walnut 069), small amounts in C (Scarlet 099), D (Veridian 209), E (Dandelion 109) and F (Silver 049). (45% Acrylic, 30% Nylon, 25% Wool 475m/100g). **MEASUREMENTS:** To fit bust 86 (91, 96, 101, 106)cm. **TENSION:** St St - 40 sts = 13.5cm and 60 rows = 15.8cm (approx T8). **RIB:** 2 x 1 (see Abbreviations) T2/2. **NOTES:** See Stitch Pattern Sheet No 5(D).

#### BACK

Using M cast on over 149 (155, 161, 170, 179) KH Ns as RIB, 000. Knit to RC36. Trans all sts to KH.



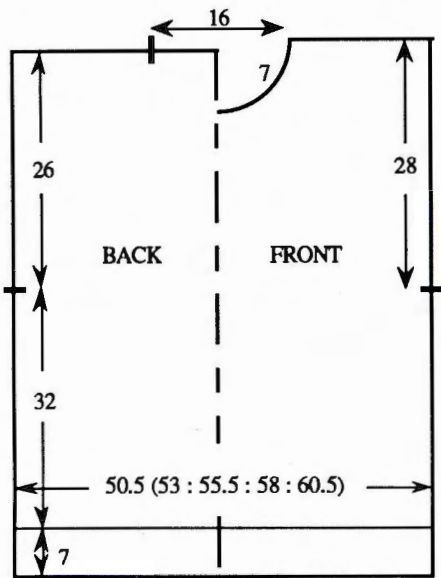

Inc 0 (2, 2, 1, 0) sts, 000. Using A T8 knit to position of first Single Motif/s. Set for first patt row and knit 1 row to select Ns. Work Single motifs throughout, at random, in cols M, B, C, D and F. Knit to RC122. Place a WY marker at each end of work. Knit to RC222. Waste knit centre 47 sts. Waste knit rem 51 (55, 58, 62, 66) sts at each end of work for shoulders.

**FRONT**  
As BACK to RC204.

**Neck shaping**  
(Note patt position if necessary). Waste knit centre 13 sts. Waste knit sts at left, COR. Knit 1 row. At beg of next and every foll alt row cast off 4 sts x 1, 3 sts x 1, 2 sts x 3, then dec 1 st x 4. Knit to RC230 and waste knit rem 51 (55, 58, 62, 66) sts. Return sts at left to Ns and knit to match right side reversing shapings.

**NECKBAND**  
Join one shoulder by placing one set of shoulder sts back onto Ns with right sides together. Using A T10 knit 1 row and cast off. Push 113 KH Ns into WP. With right side facing, pick up same number of sts evenly along neck edge and place onto Ns. Using M T8 knit 1 row. Trans to RIB, making sts as necessary, 000. Knit to RC26. Trans all sts to KH. T8 knit 2 rows and waste knit. Join second shoulder as first. Join NECKBAND seam, fold in half to outside and backstitch to garment through last row knitted in M.

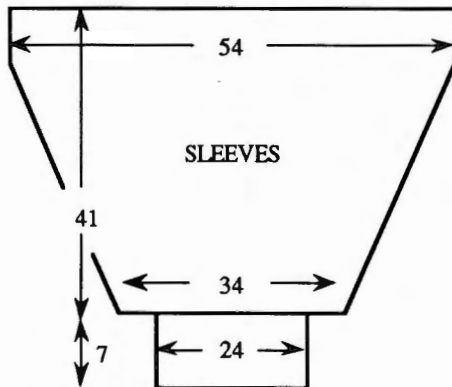

**LEFT SLEEVE**  
Push 160 KH Ns into WP. With wrong side facing, pick up same number of sts evenly along armhole edge between WY markers and place onto Ns, 000. Using M and working Single Motifs, UPSIDE DOWN, knit to RC6. Dec 1 st at each end of next and every foll 5th row x 30. Knit to RC156 and waste knit rem 100 sts. CUFFS: Push 71 KH Ns

into WP. With wrong side facing, place sts from cuff edge back onto Ns distributing them evenly along the row. Trans to RIB, 000. Using M knit to RC35. T10/8 knit 1 row. Trans all sts to KH and latch cast off each st individually.

**RIGHT SLEEVE**  
As LEFT SLEEVE using B for background and M, A, C, D and F for Single Motifs.

**MAKE-UP**  
Using E, swiss darn centre of flowers as illustrated. Join side and SLEEVE seams.



**MACHINES:** A, C or D and KR. **MATERIALS:** ATKINSON YARNS DESIGNER COLLECTION Wharfedale; M - 220 (230, 240, 250, 260)g (Royal 119), A - 150 (160, 170, 180, 190)g (Scarlet 099), B - 130 (140, 150, 160, 170)g (Veridian 209), C - 105 (115, 125, 135, 145)g (Dandelion 109), small amount of D (Navy 109). (45% Acrylic, 30% Nylon, 25% wool 475m/100g). 9 Buttons. **MEASUREMENTS:** To fit bust 86 (91, 96, 101, 106)cm. **TENSION:** Fairisle St Patt - 40 sts = 13.2cm and 60 rows = 16.9cm (approx T8). **RIB:** 2 x 1 (see Abbreviations) T2/2. **NOTES:** See Stitch Patt Sheet No 5(B). For SLEEVES diagram see Patt No 21.

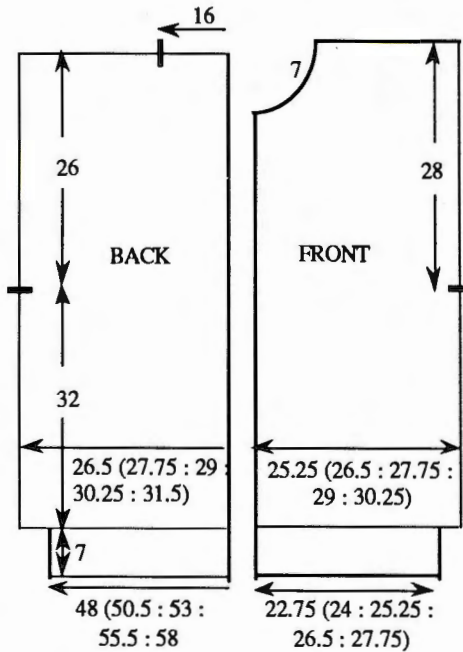

**LEFT BACK**  
Using WY cast on over 80 (84, 88, 92, 96) KH Ns and knit a few rows ending with COL. Using A T8 knit 1 row, 000. Knit to RC2. Set for first row of St Patt and knit 1 row to select Ns. Working in fairisle \*with A in FA throughout, knit 6 rows with B in FB and 15 rows with M in FB. Using A only knit 3 rows\*. Repeat from \* to \* throughout. Knit to RC114. Place a WY marker at right end of work. Knit to RC206. Waste knit 24 sts at left. Waste knit rem 56 (60, 64, 68, 72) sts.

**RIGHT BACK**  
As LEFT BACK reading right as left, M as A, and vice versa.

**BACK WAIST RIB**  
Join centre BACK seam. Push 143 (149, 155, 161, 167) KH Ns into WP. \*\* With wrong side facing, place sts from waist edge onto Ns distributing them evenly along the row. Trans to RIB making sts as necessary, 000. Using M knit to RC35. T10/8 knit 1 row. Trans to KH and latch cast off each st individually \*\*.

**RIGHT FRONT**  
As LEFT BACK, using 77 (81, 85, 89, 93) KH Ns, to RC191, COL.

**Neck shaping**  
\*\*\* At beg of next and every foll alt row cast off 7 sts x 1, 4 sts x 1, 3 sts x 1, 2 sts x 2, then dec 1 st x 3. Knit to RC214 and waste knit rem 56 (60, 64, 68, 72) sts\*\*\*.

**LEFT FRONT**  
As RIGHT BACK, using 77 (81, 85, 89, 93) KH Ns, to RC190, COR. Repeat from \*\*\* to \*\*\*.

**FRONT WAIST RIBS**  
Push 68 (71, 74, 77, 80) KH Ns into WP. Repeat from \*\* to \*\*.

**LEFT SLEEVE**  
Join shoulders by placing both sets of shoulder sts onto Ns with right sides together. Using M T10 knit 1 row and cast off. Push 163 KH Ns into WP. With wrong side facing, pick up same number of sts evenly along armhole edge between WY markers and place onto Ns, 000. Using C knit to RC2. Set to knit St Patt UPSIDE DOWN and knit 1 row to select Ns. Working in fairisle \*\*\*\* with C in FA throughout, B in FB knit 15 rows, D in FB knit 6 rows. Using C only knit 3 rows \*\*\*\*. Repeat from \*\*\*\* to \*\*\*\* throughout. Knit to RC26. Dec 1 st at each end of next and every foll 4th row x 30. Knit to RC146 and waste knit rem 103 sts. **CUFFS:** Push 74 KH Ns into WP. With wrong side facing, place sts from CUFF edge back onto Ns distributing them evenly along the row. Trans to RIB, 000. Using M knit to RC35. T10/8 knit 1 row. Trans all sts to KH and latch cast off each st individually.

**RIGHT SLEEVE**  
As LEFT SLEEVE reading B as C, C as B and M as D.

**NECKBAND**  
Using M cast on over 110 KH Ns as RIB, 000. Knit to RC12. Trans all sts to KH. T8 knit 1 row. With wrong side facing, pick up same number of sts evenly along neck edge and place onto Ns. T10 knit 1 row and cast off.

**BUTTONHOLE BAND**  
Using M cast on over 185 KH Ns as RIB, 000. Knit to RC6. Make 9 x 2 st buttonholes starting with the 5th and 6th Ns at right end and counting 20 Ns in between each buttonhole. Knit to RC12. Trans all sts to KH. T8 knit 1 row. With wrong side facing, pick up same number of sts evenly along RIGHT FRONT opening edge and NECKBAND and place onto Ns. T10 knit 1 row and cast off.

**BUTTON BAND**  
as BUTTONHOLE BAND omitting buttonholes.

**MAKE-UP**  
Join side and SLEEVE seams. Attach buttons. Swiss darn centre of "flowers":- BACK and FRONT use C, SLEEVES use A.



# Stitch Pattern Sheet No 1

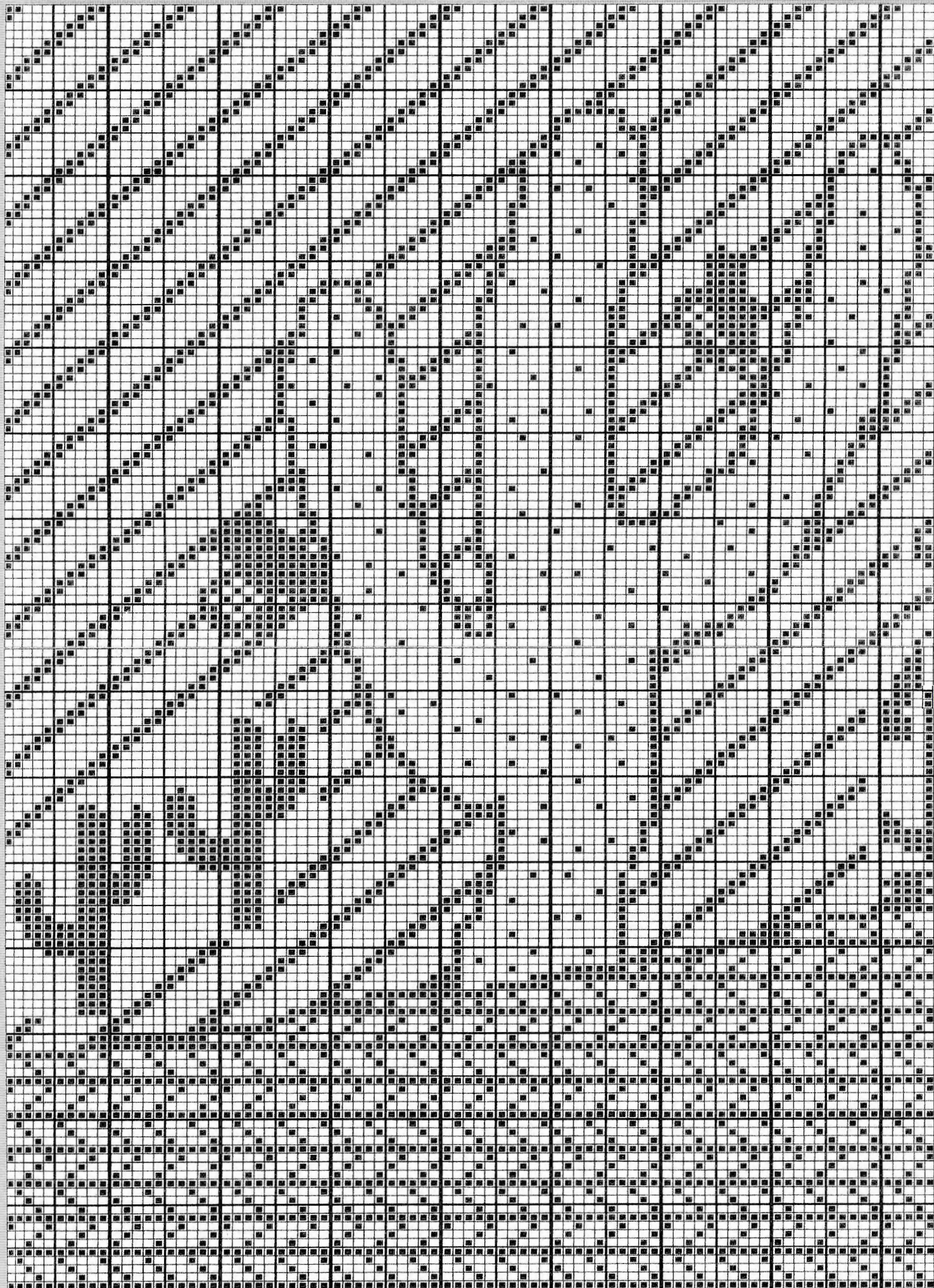



# Stitch Pattern Sheet No 2

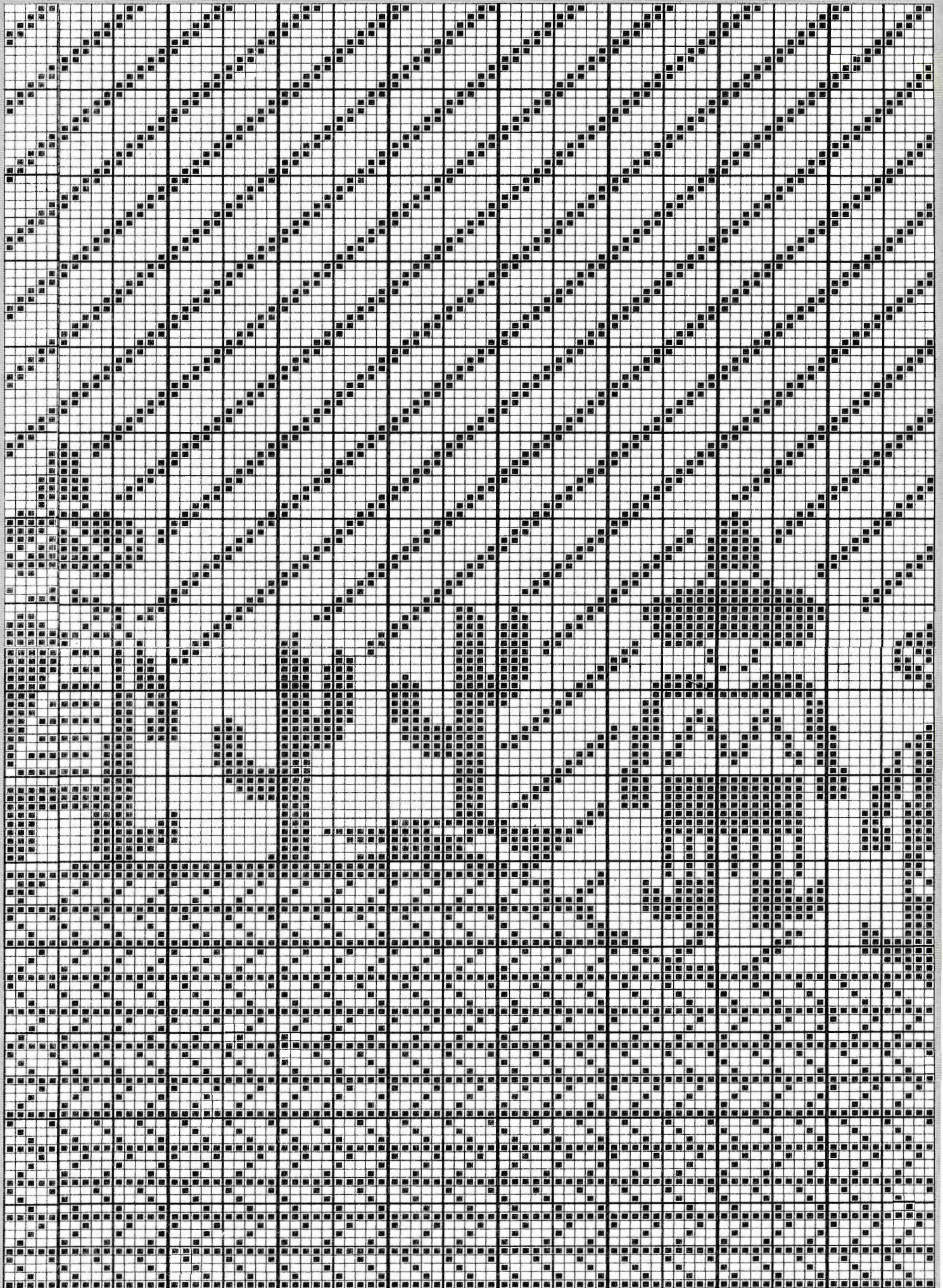



# Stitch Pattern Sheet No 3

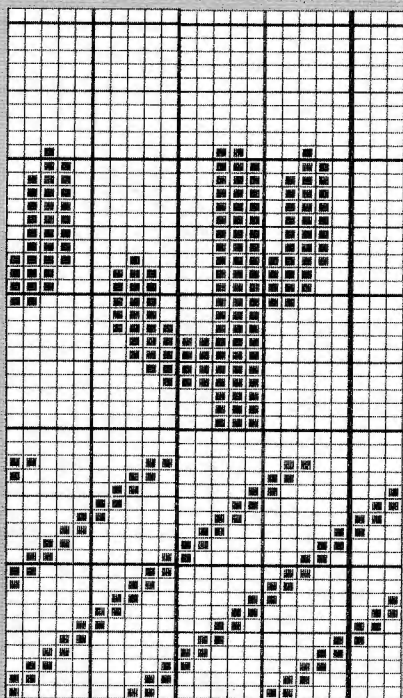
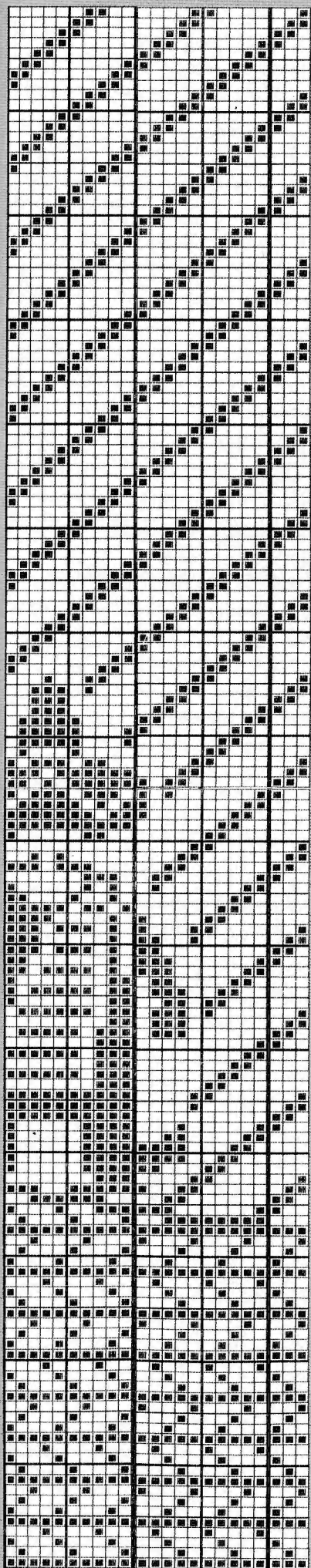

F

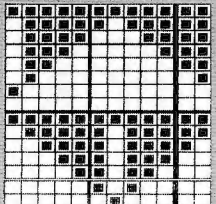

9

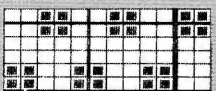

8

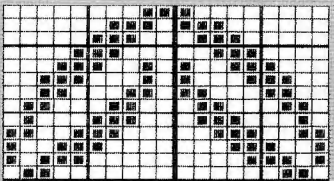

7

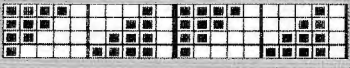

6

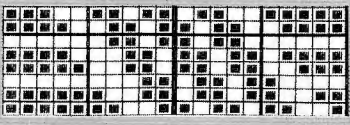

5

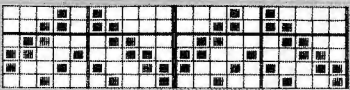

4

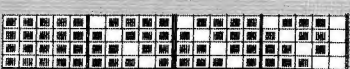

3

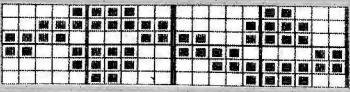

2

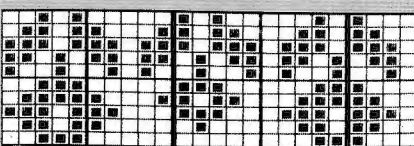

1

D	4	E	4	F	3
1		2		3	
A	B		C		

No 1

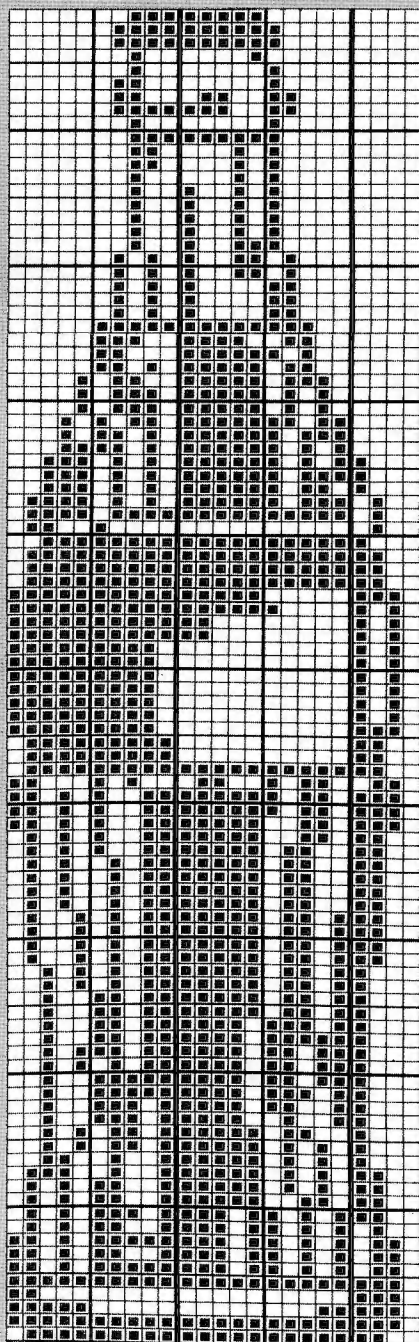

A

B

C



# Stitch Pattern Sheet No 4

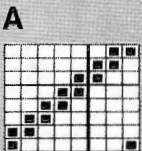
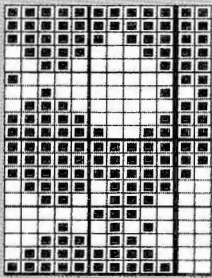
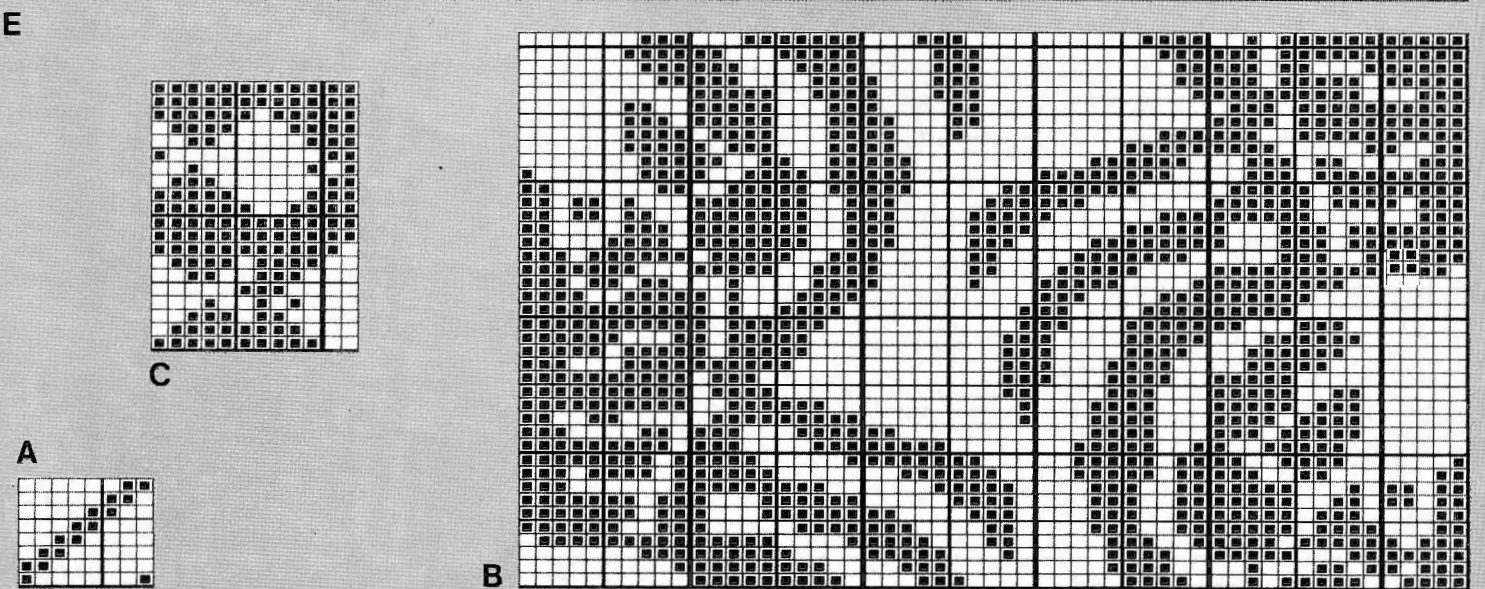
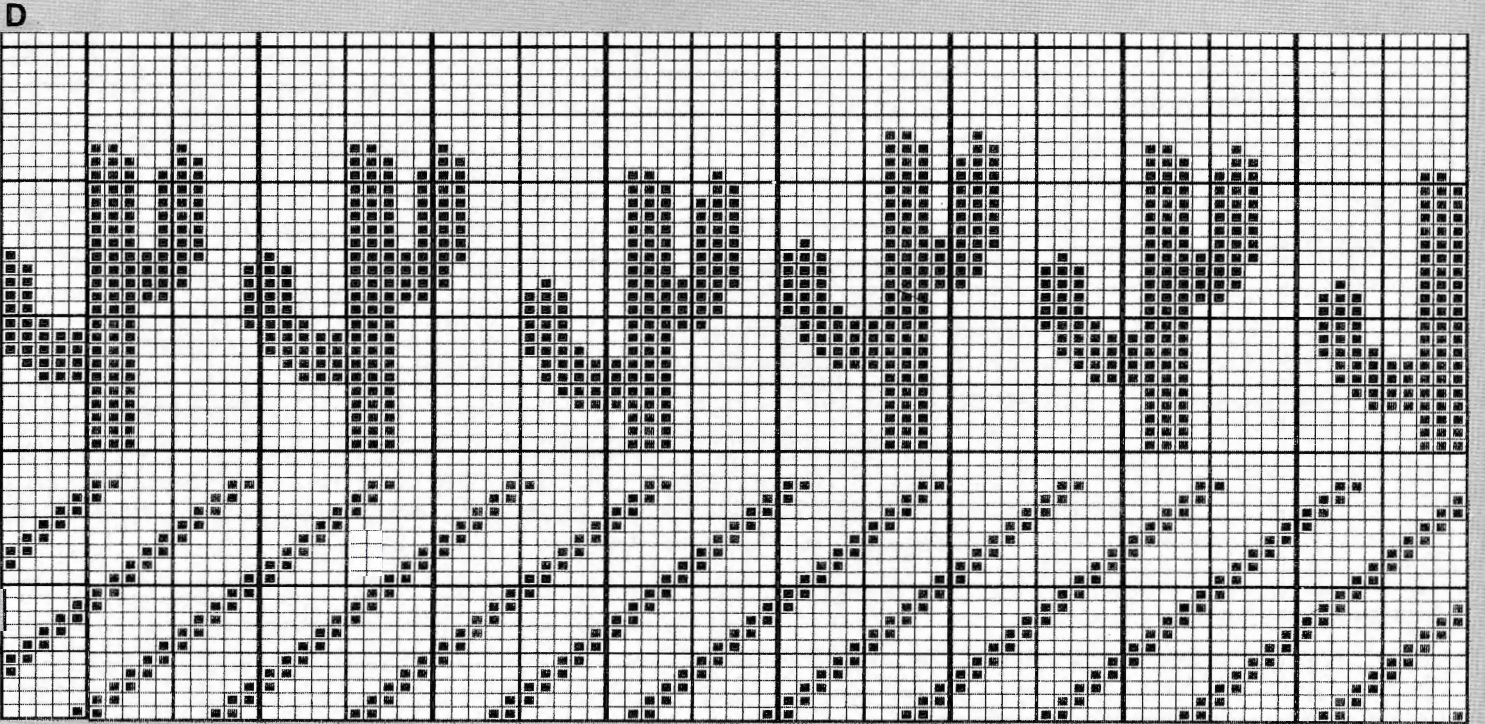
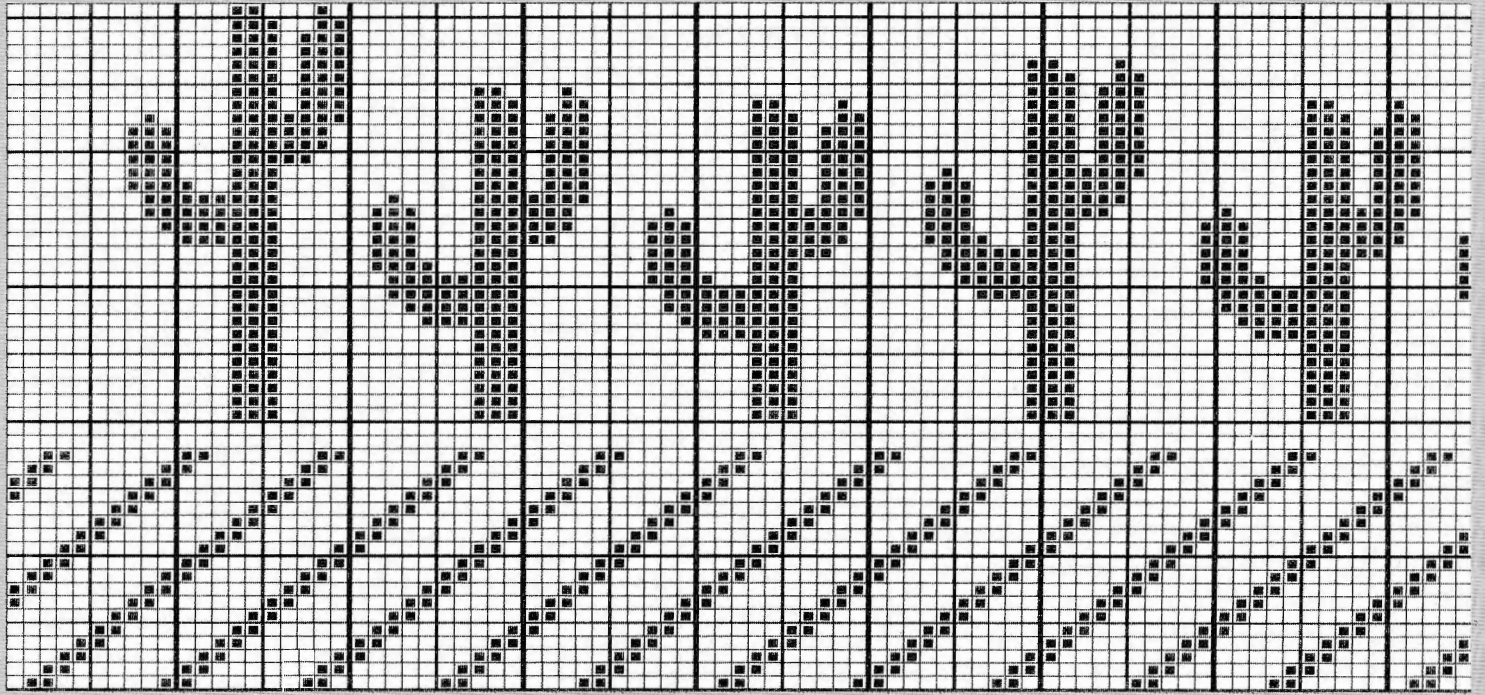

D

E

C

A

B



# Stitch Pattern Sheet No 5

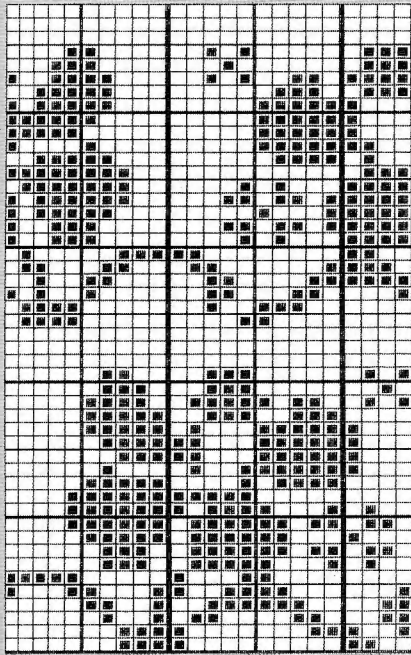

B

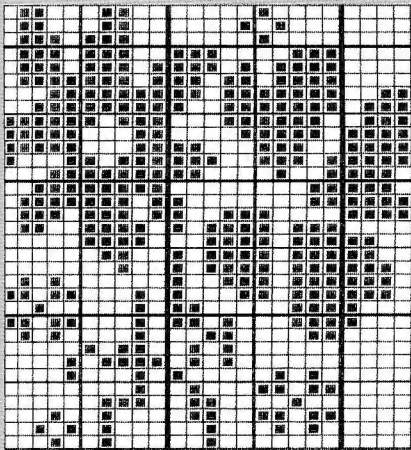

D

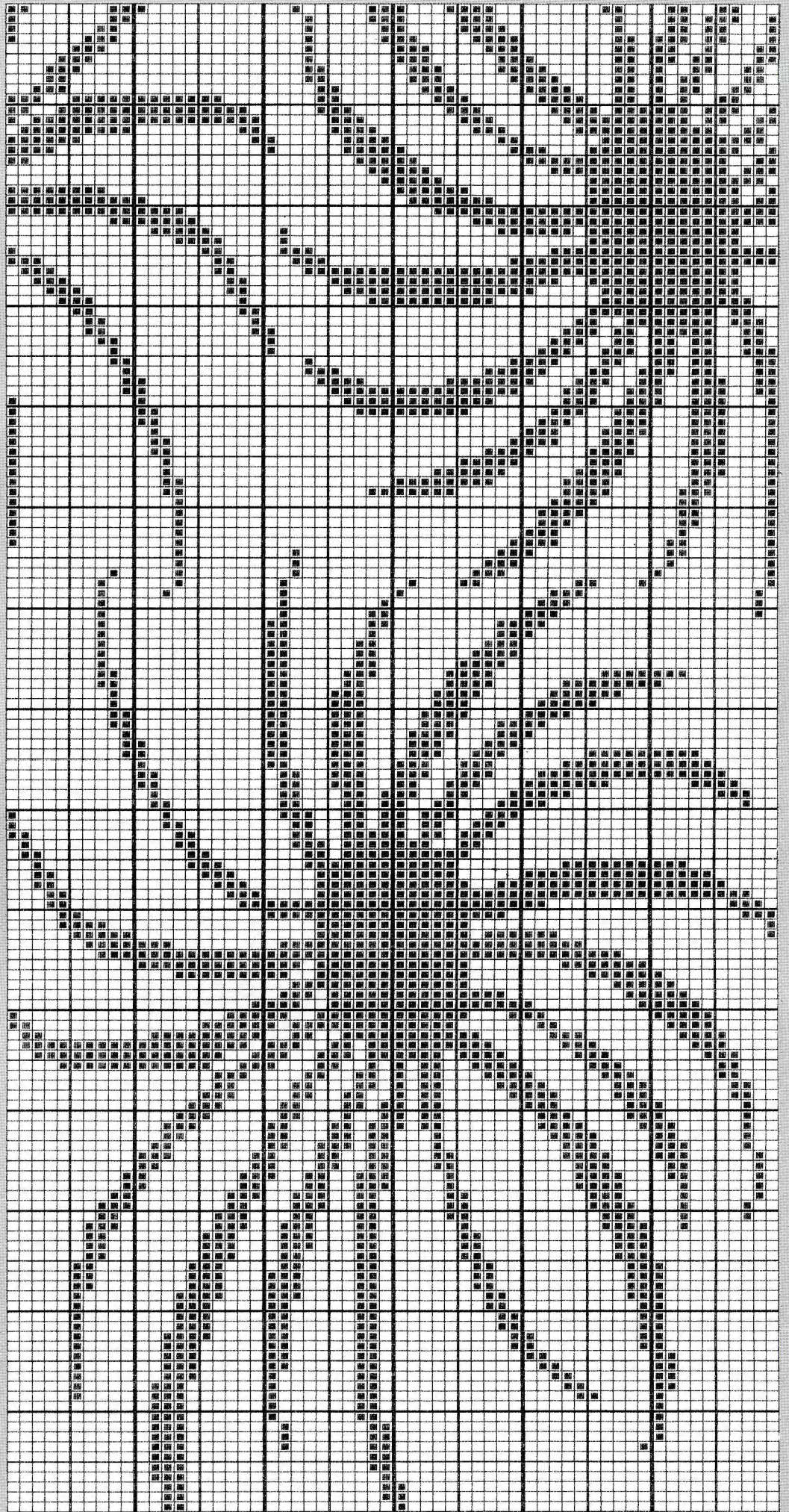

A



# Stitch Pattern Sheet No 6

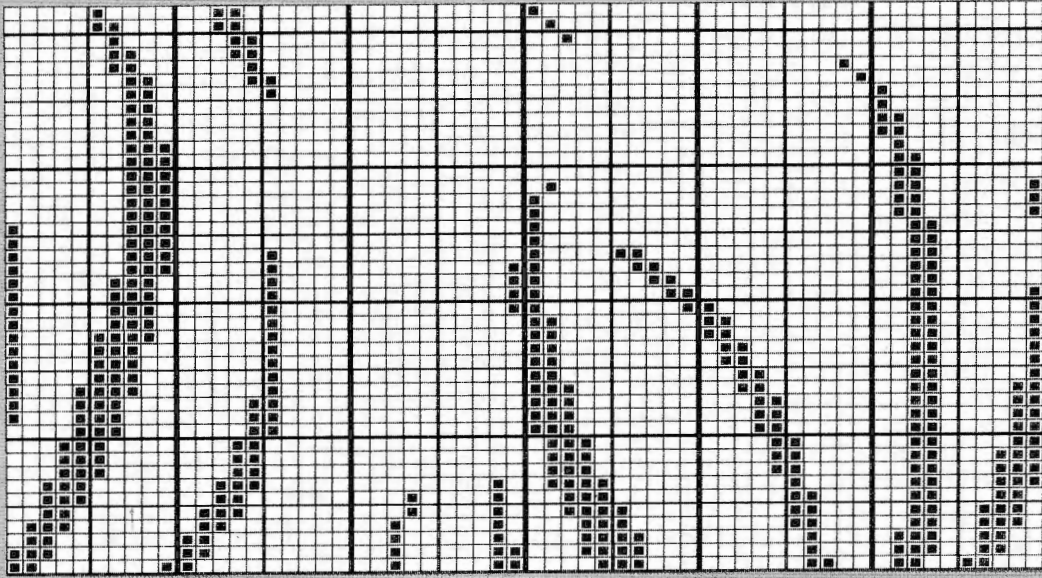

B

B	6
5	
A	

No 3

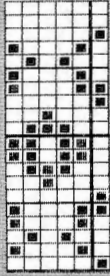

C

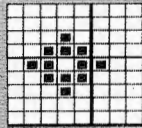

D



E

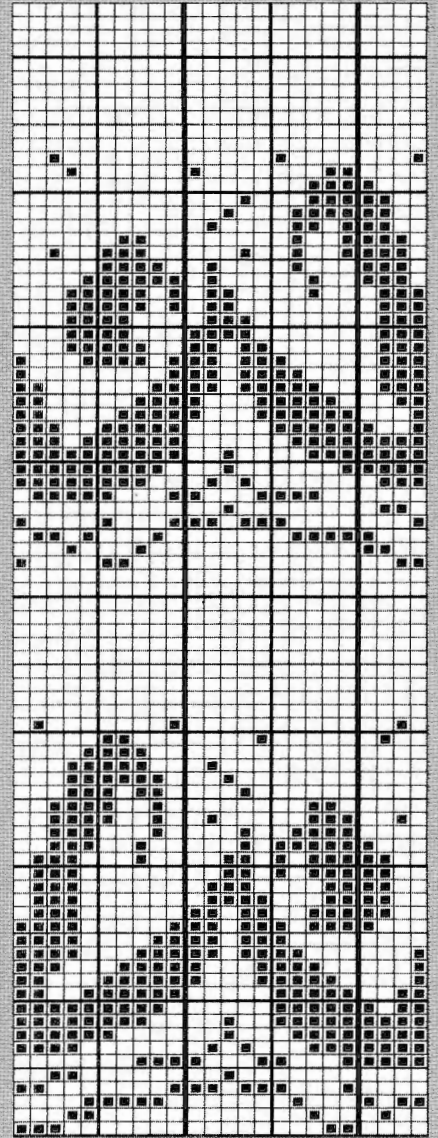

F



# Stitch Pattern Sheet No 7

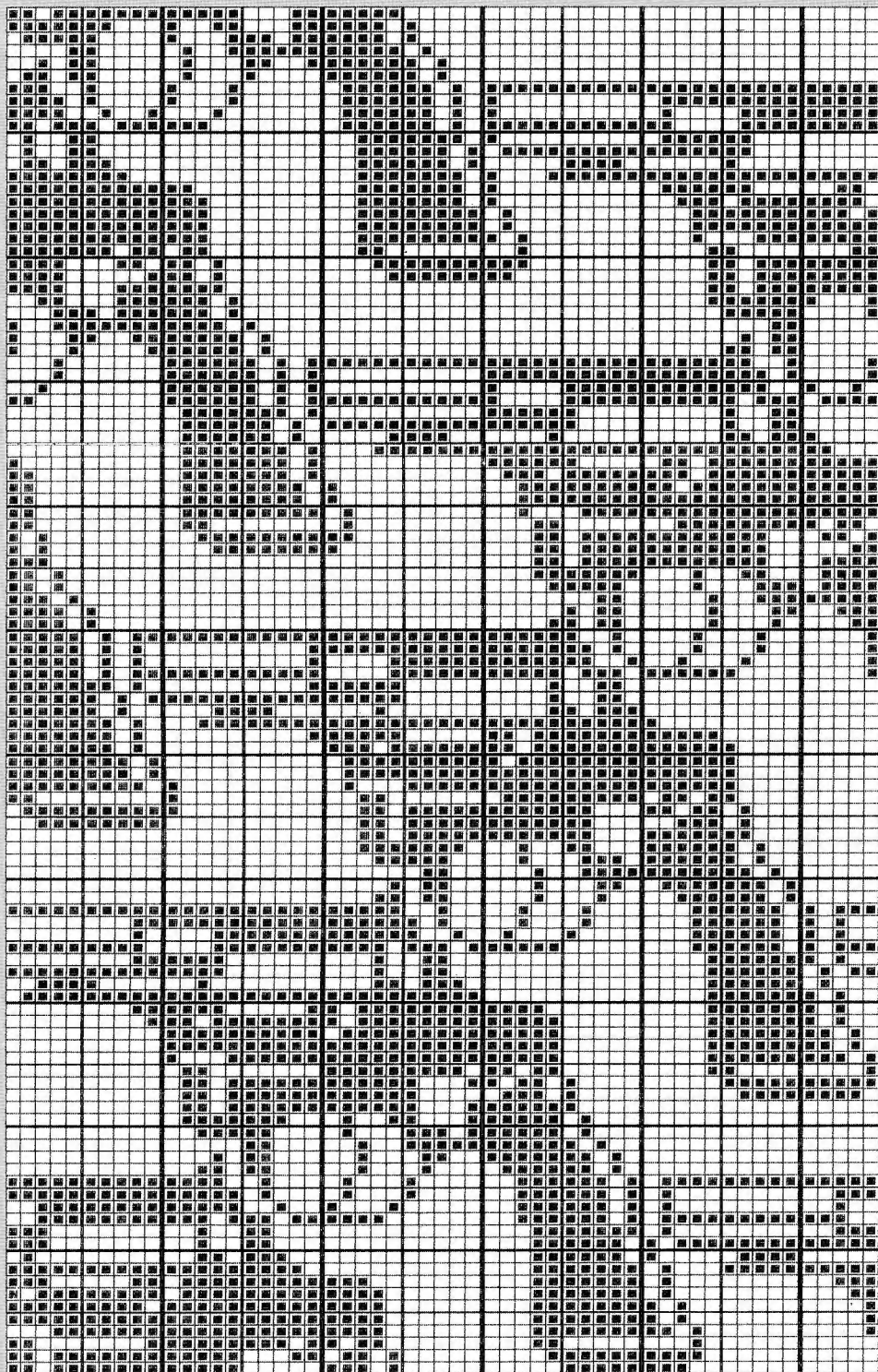

A

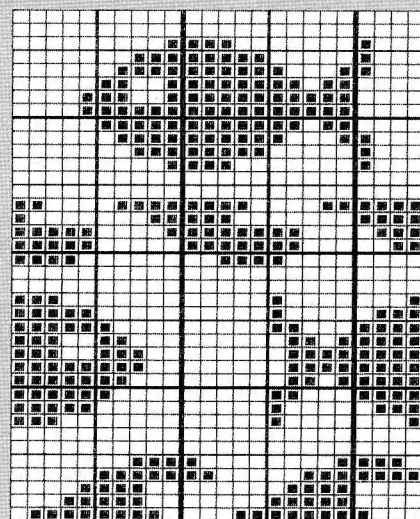

B

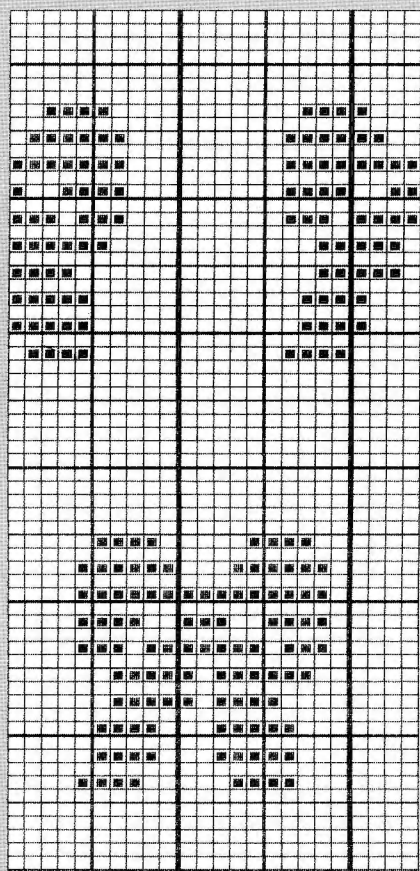

C

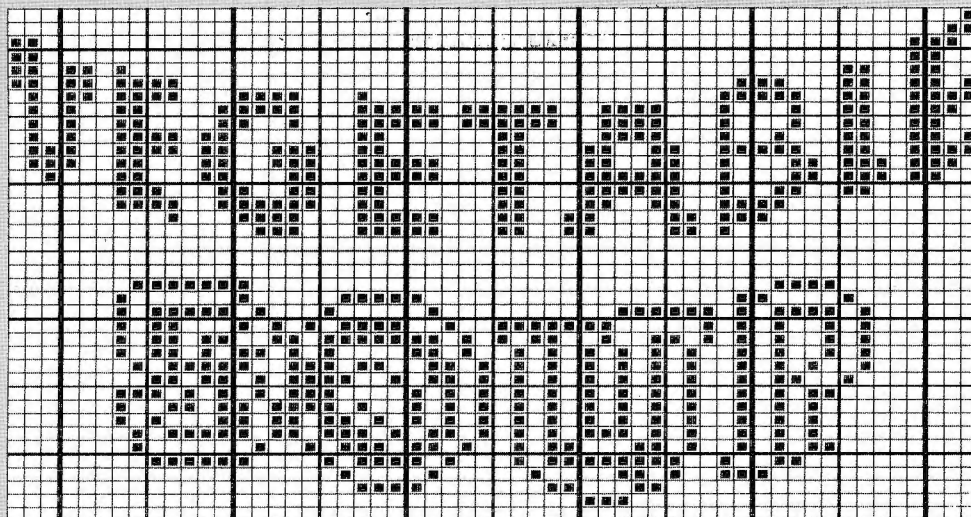

D



# Stitch Pattern Sheet No 8

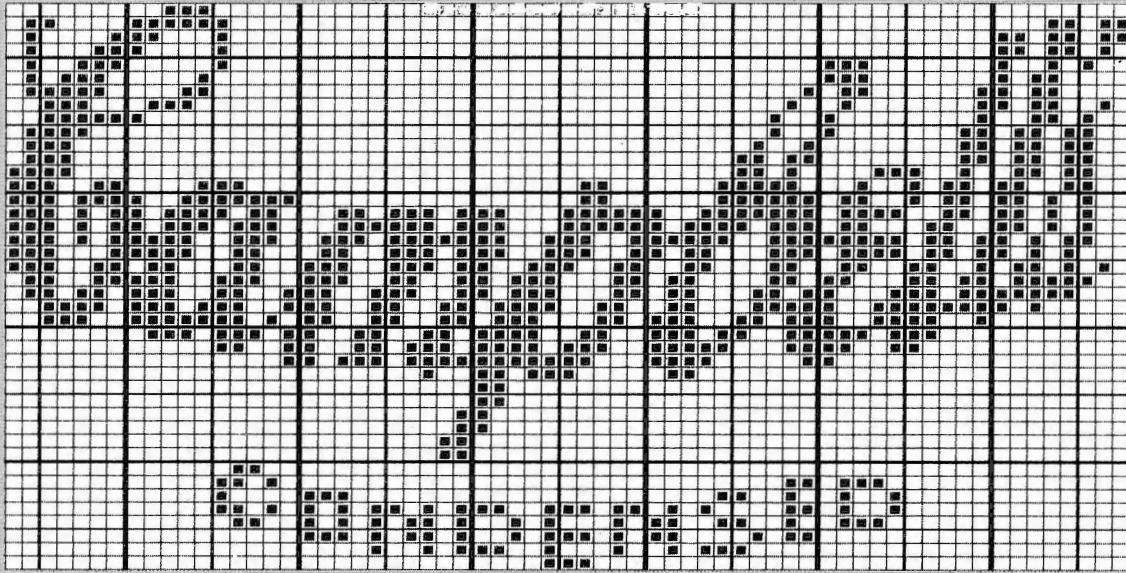

A

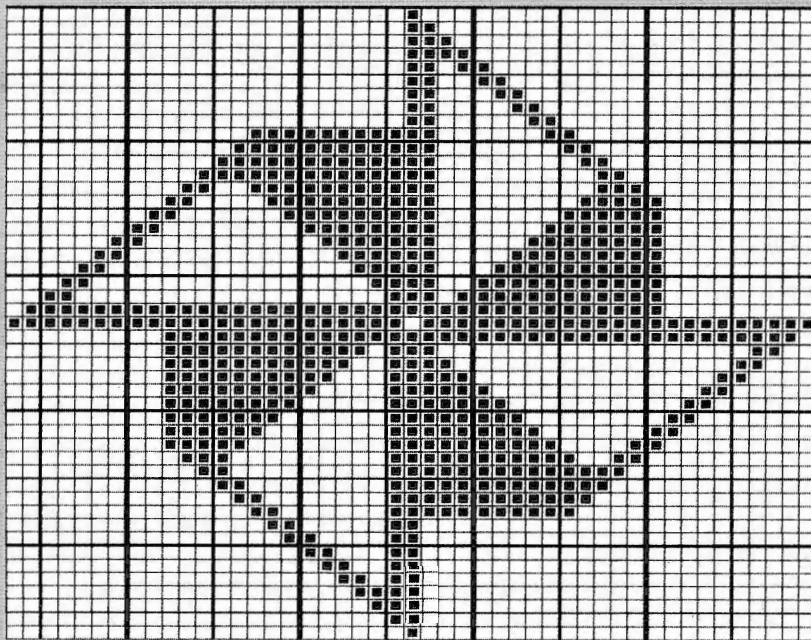

B

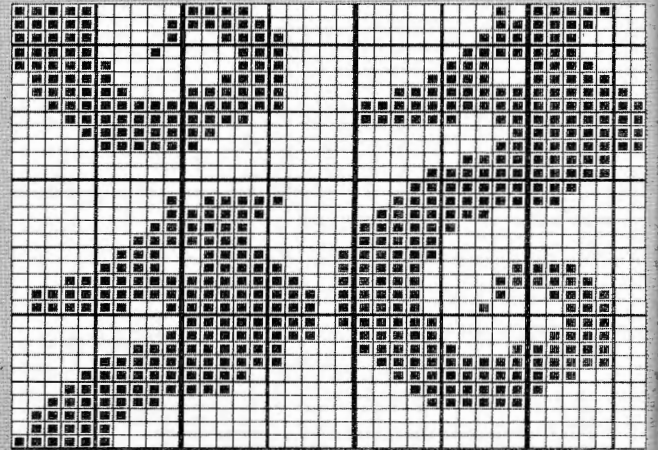

C

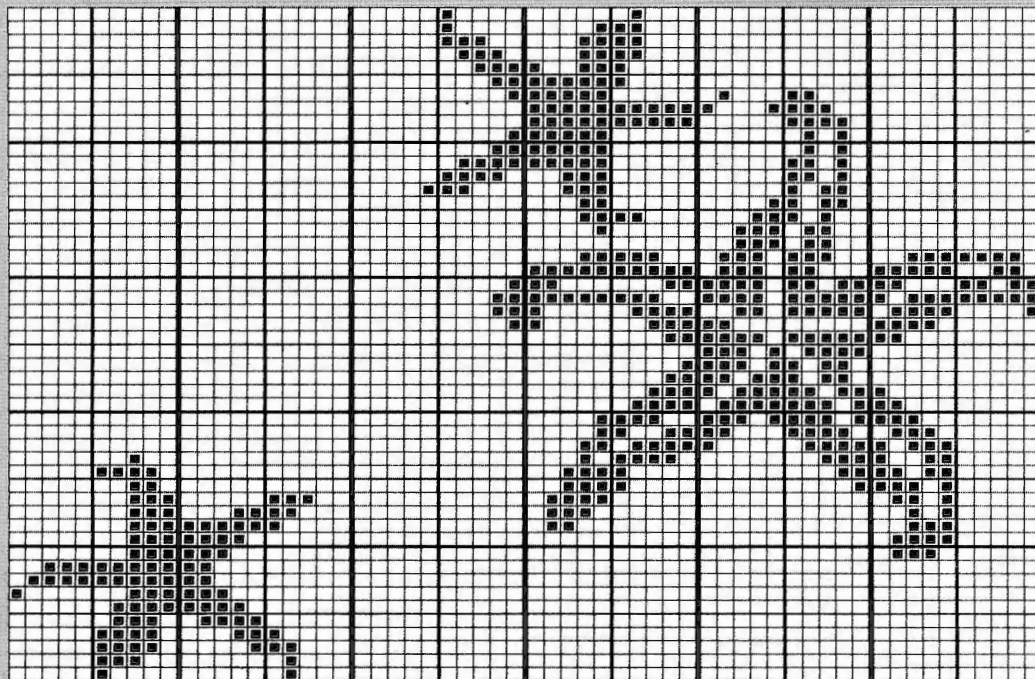

D



# Stitch Pattern Sheet No 9

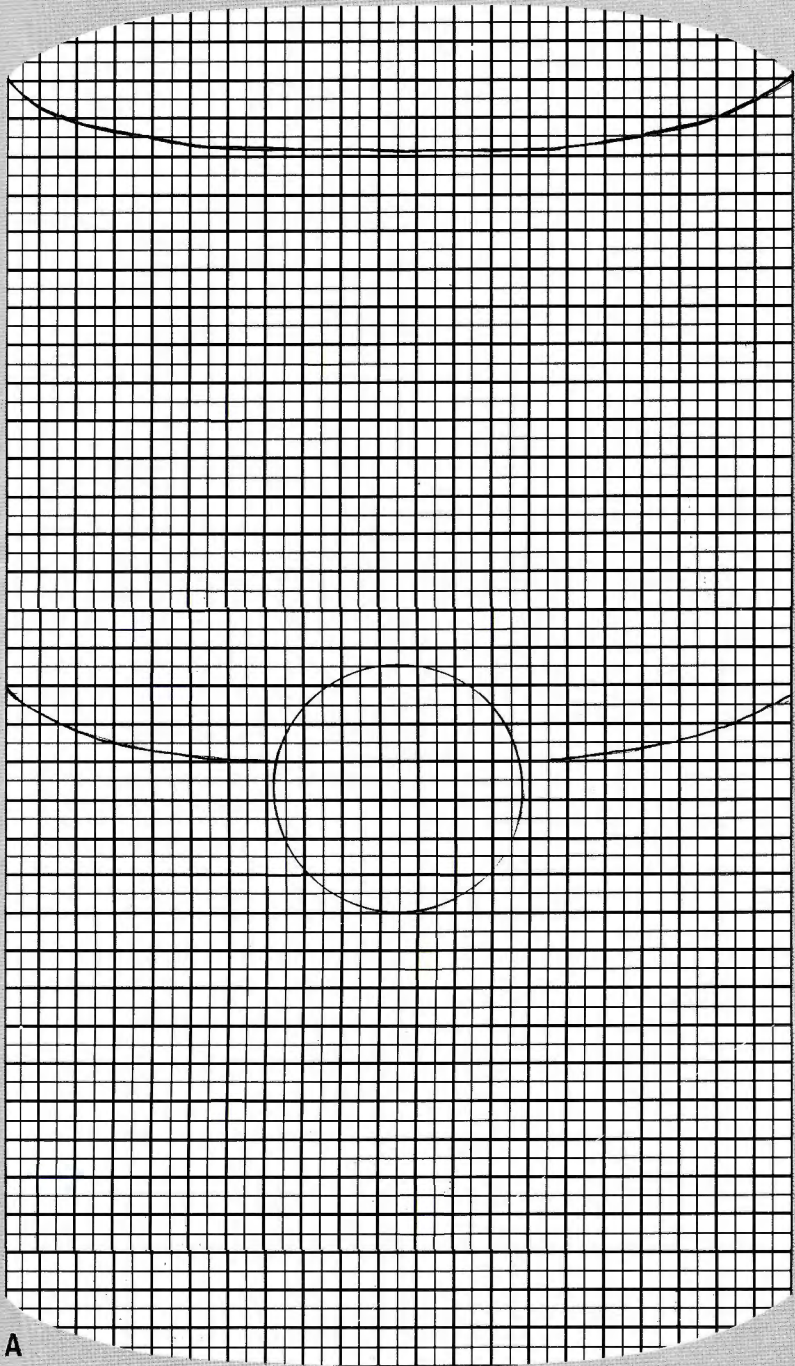

A

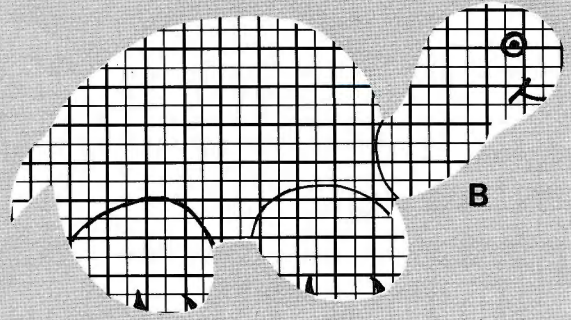

B

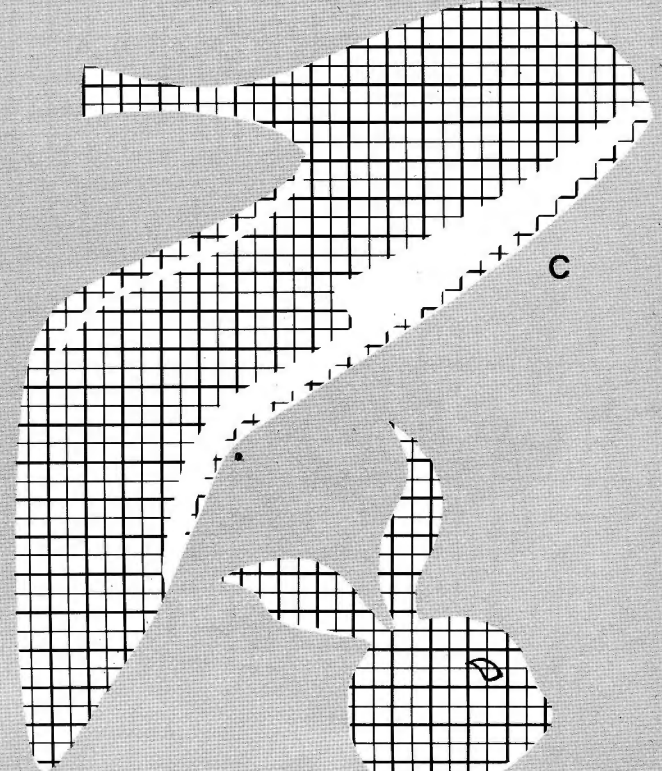

C

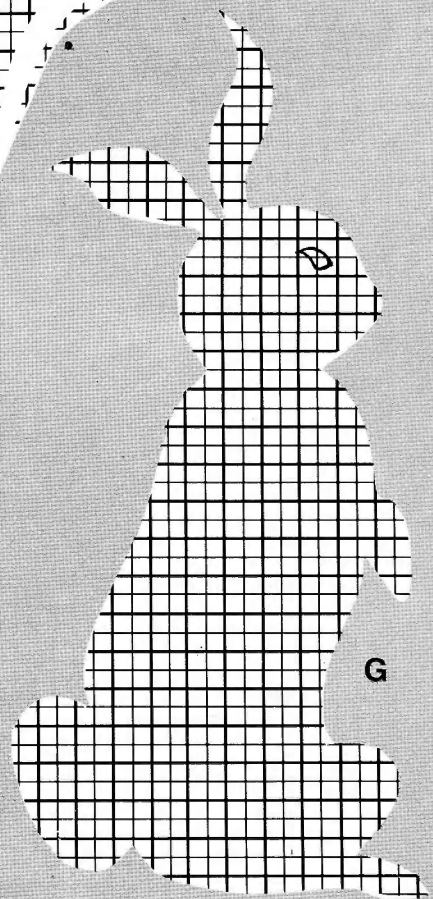

G

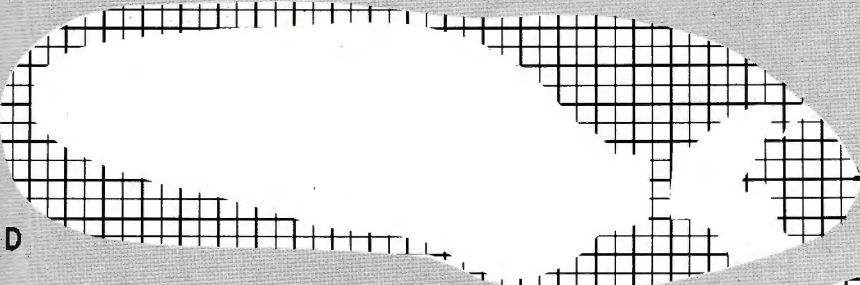

D

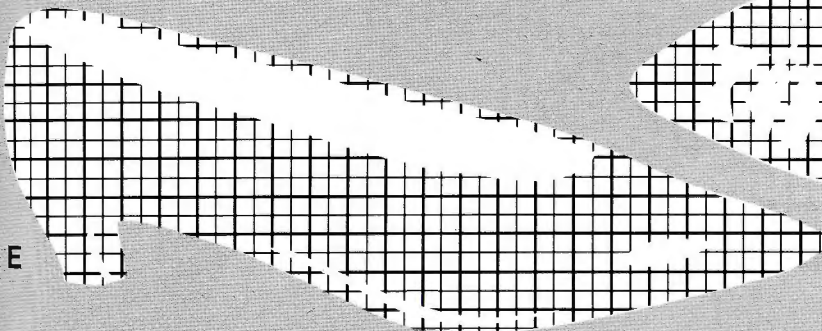

E

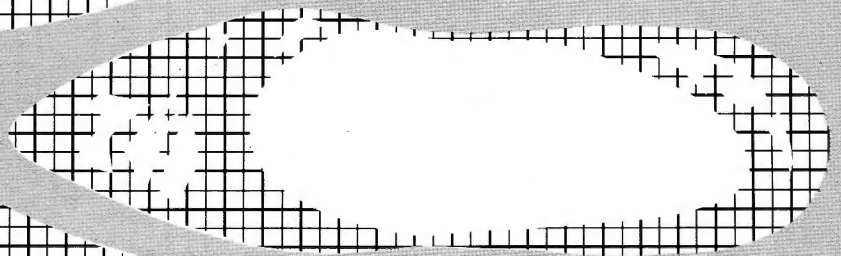

F



# Stitch Pattern Sheet No 10

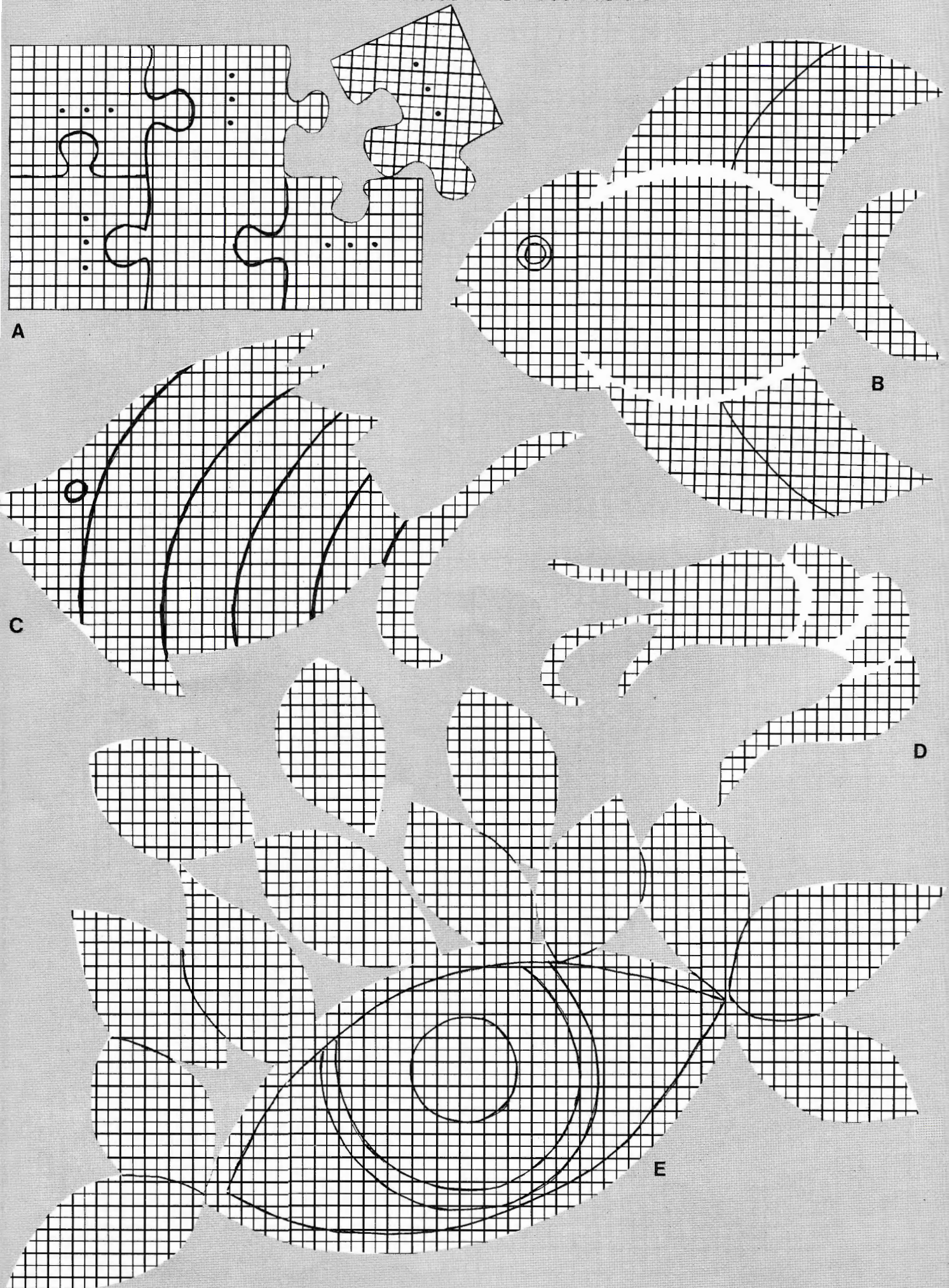



# Stitch Pattern Sheet No 11

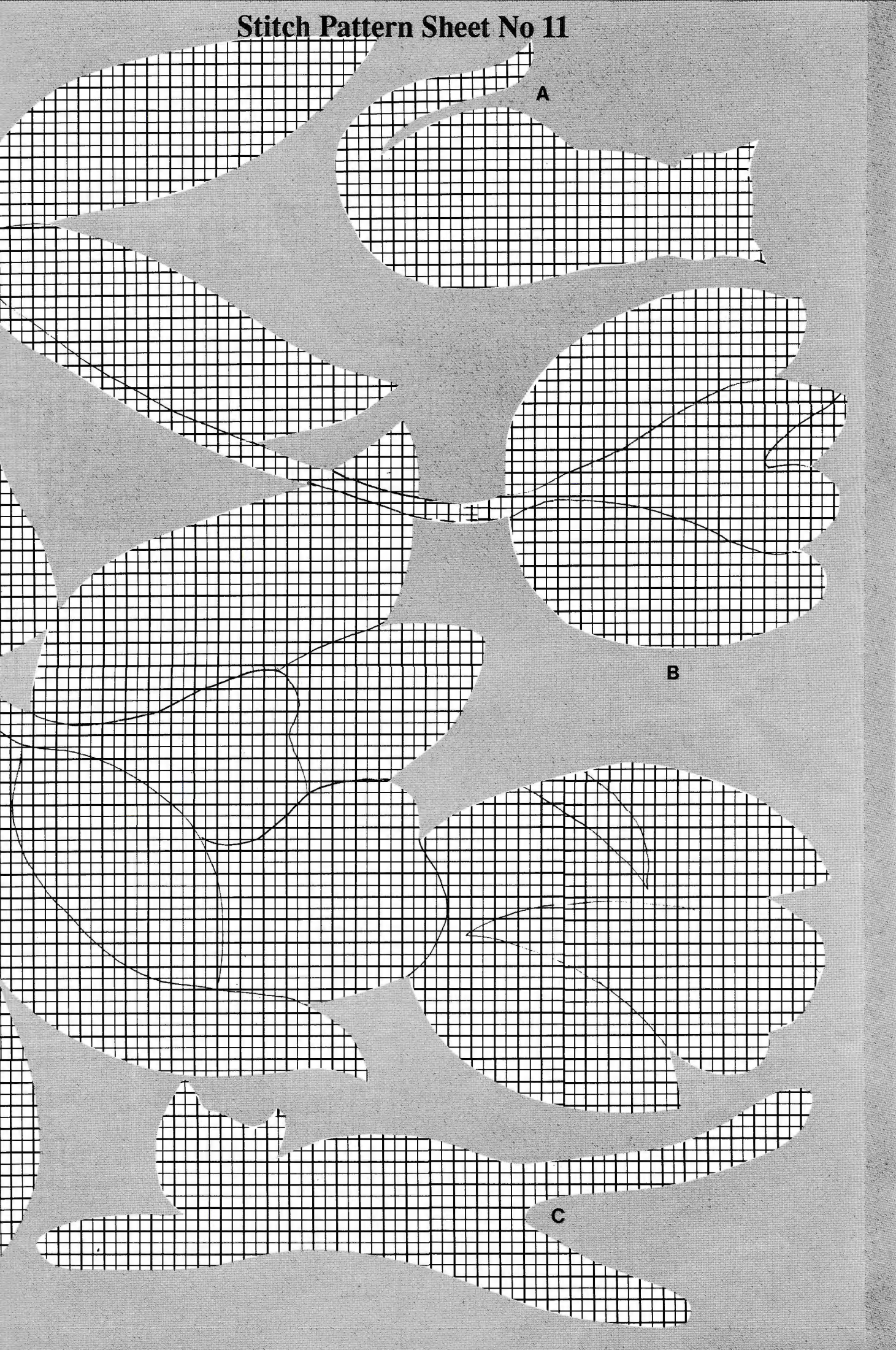

A

B

C

a  
b  
c  
C  
C  
C  
C  
C  
d  
F  
F  
f  
g  
G  
H  
H  
ir  
K  
K  
K  
L  
M  
M  
N  
N  
p  
R  
re  
O  
st  
st  
T  
tr  
U  
W  
W  
C  
c  
de  
ss  
t  
2  
M  
A  
B  
B  
C  
D  
N  
A  
A  
S  
G  
Y  
R  
2  
C  
B  
2  
ir



# Stitch Pattern Sheet No 12

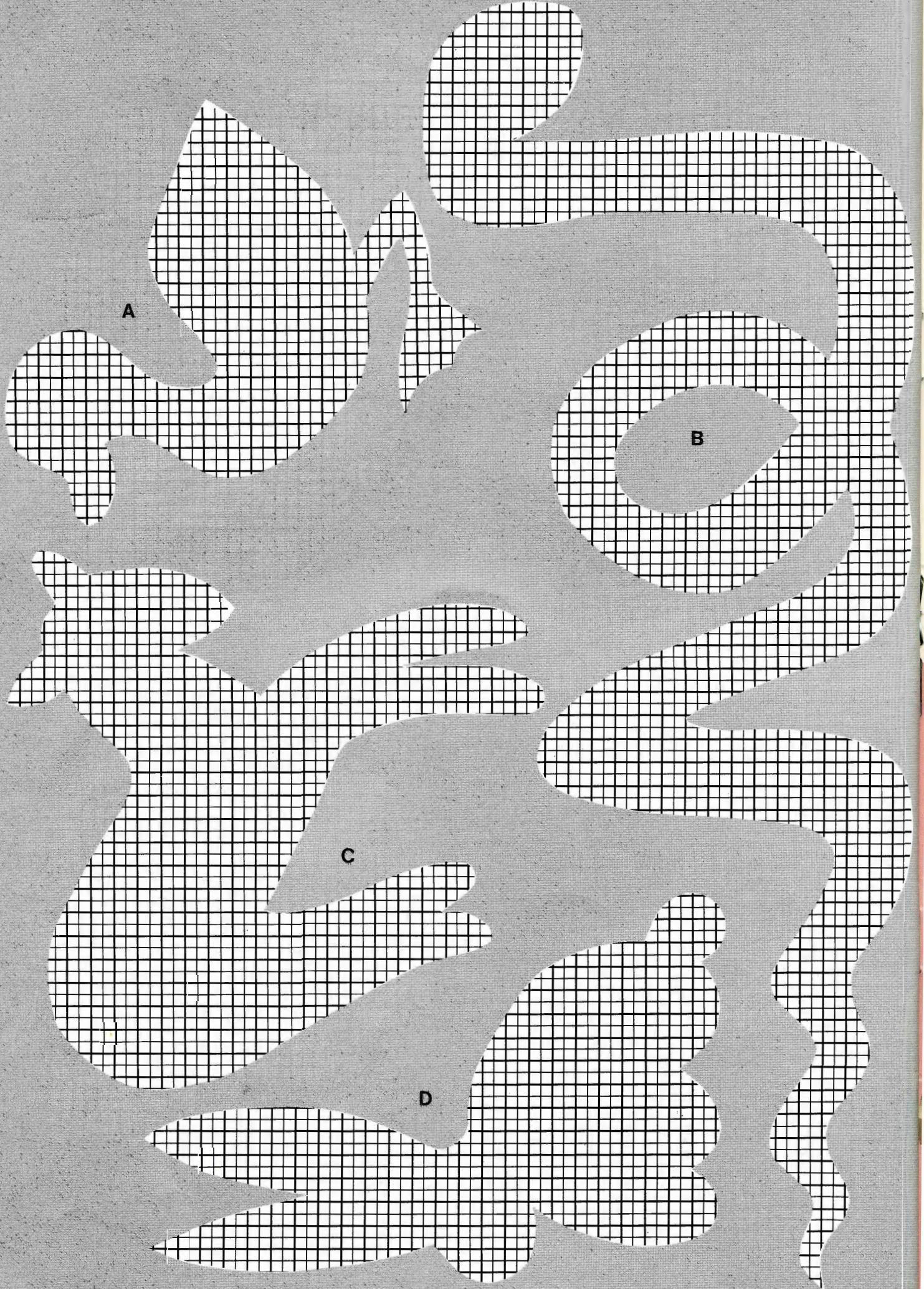



# ANDY WARHOL

## HIGH PRIEST OF POP ART

Is it art? Or was it a con? Rows of Campbell's Soup Cans, brightly coloured pictures of Marilyn Monroe, multiple images of guns, of dollar bills, of Coca-Cola bottles. Paintings that are bold and bright, everyday objects and familiar faces, large and colourful. And lots of them! that is the style of the American pop artist Andy Warhol. And that's the theme we've chosen for this particular collection. Opinion has long been divided as to whether Andy Warhol was, indeed, a genius – creating a whole new approach to art, using familiar images over and over again with only tiny, almost subtle changes between each one. Or was he a sham? Cashing in on a New York society of the 1960s that was ready to latch onto something completely alien to accepted art forms?



*Andy Warhol used screen printing in much of his work. He often printed the basic image over and over again and then added details transforming each of them into something quite different. We have used the very famous face of Marilyn Monroe as a single motif and then embroidered the lips and eye shadow to achieve a similar effect! The sweater is knitted in strips and then sewn together – full instructions can be found in the Centre Section No 13.*

Whatever the answer, Warhol became a cult figure in both the art and film worlds without ever allowing his own character and personality to shine through. He has been described as one of the most enigmatic artists of all time; he himself said there was no deeper meaning to his work: "If you want to know all about Andy Warhol, just look at the surface of my paintings and films and me, and there I am. There's nothing behind it."

Even Warhol's birth-date has never been verified: it's judged to be around August 6th and varying in years from 1927 to 1930. And Warhol was always reluctant with interviewers to give any personal background.

"I make it all up, differently every time I'm asked," he used to say.

What has been gleaned of his background is that he was born as Andy Warhola, the son of immigrants from Czechoslovakia who settled in Philadelphia – his father a coal miner. His mother, Julia recounts that, as a child, Andy was fond of cutting pictures out of comic books as well as drawing his own.

After early employment selling fruit from a truck and decorating windows in a Pittsburgh department store, Warhol attended the Carnegie Institute of Technology. He arrived in New York city in 1949 and his first ten years here were spent as a commercial artist – as a fashion illustrator and advertisement designer. His first major recognition came in 1957 when he received an award for a giant shoe advertisement.

Warhol did not begin to paint until 1960, at first concentrating on large works based around popular 'commercial' art of the time – comic strips characters, like Dick Tracy; magazine photographs of popular film stars and advertisement illustrations of mass-produced consumer goods.

His painting, together with those of his contemporary Roy Lichtenstein, soon became the centre of the new genre of "Pop Art" – a rebellion against the prevailing fashion for abstract expressionism.

Warhol then began using the device of repetition that has since become one of his most distinctive trademarks: the same image, face, photograph, newspaper cutting, dollar bill – over and over again, filling the canvases from edge to edge.

Andy Warhol loved to paint those things that most people would consider boring but which he thought beautiful – everyday objects that normally would never be



given a second glance. The Campbell's Soup Can was one of his early triumphs. These were painted singly, in pairs, in groups of one hundred and two hundred, open and closed, with the labels peeling off.

"I like boring things", Warhol said. "I like things to be exactly the same over and over again."

Coca-Cola bottles were another image that caught his fancy – row upon rows of them, green and brown. The reason he painted this way, he would explain, was because he wanted to be a machine.

I think everybody should be a machine. I think everybody should be like everybody," he claimed and indeed, he even called his studios "Factories" where he and his followers mass-produced their art. Despite that desire for uniformity of people and paintings, Warhol was fascinated by the idea of stardom: the show-biz and glamour personalities of his generation. His famous subjects included Marilyn

*When using a knitting machine the stitch pattern repeats appear as separate images across the fabric. By changing one or two of them the pattern repeats are brought together to form one overall design! This concept has been applied to the man's fairisle sweater at the right – full instructions are to be found in the Centre Section No 11.*

*Andy Warhol experimented with all kinds of shapes, colour and subject matter when he screen printed. The pattern repeats he used are excellent inspiration for machine knitters – full instructions for this fabulous "Gun" sweater are to be found in the Centre Section No 12.*

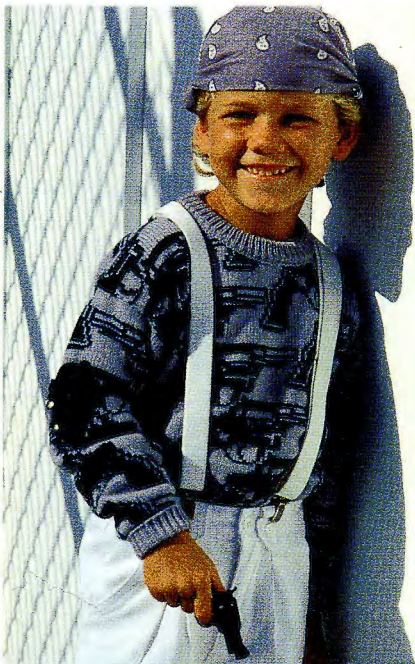
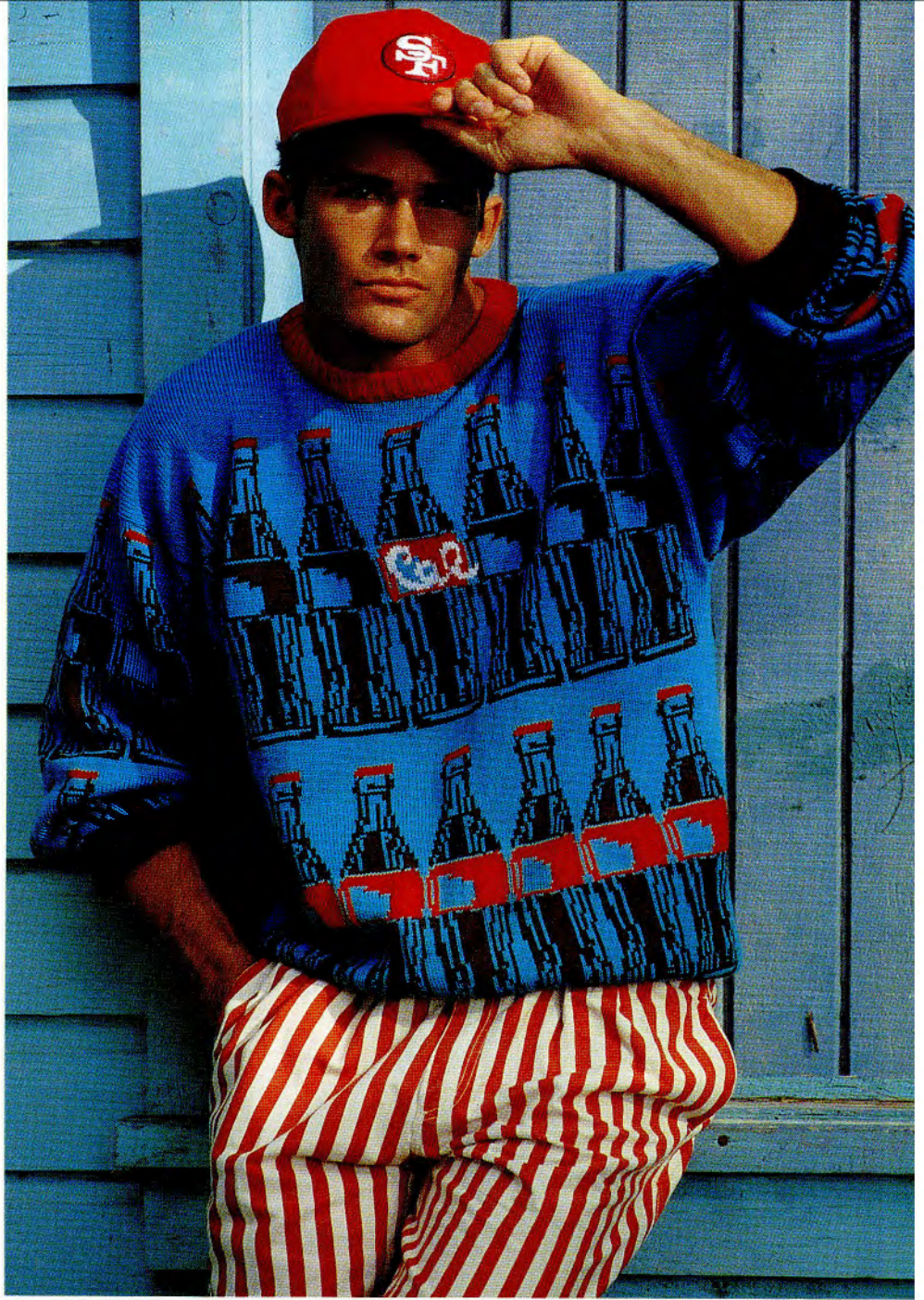





Monroe, Jackie Onassis, Elizabeth Taylor, Liza Minelli, Elvis Presley, Mick Jagger and Chairman Mao.

Warhol's sculptures were as controversial as his paintings, following the same theme of common objects and repetition: like the rows upon rows of Brillo soap pad shipping cartons he had specially made and which were later put on sale for \$300 each!

Warhol retired from his painting career in 1965, turning first to film making, where repetition again played a central theme: one of his epics was simply an eight-hour view of one side of the Empire State building – the artist himself fascinated by the variations in light and shadow as reflected on the building during a day.

Next, he opened his own nightclub and promoted the band "The Velvet Underground" that was to become one of the most influential in rock music. Finally, he started a gossip magazine "Andy Warhol's Interview" – another outlet for his ideas. But it will certainly be for his painting that Andy Warhol is best remembered: they have a recognizability that almost rivals that of Picasso, Gauguin and Rembrandt. Would Warhol have been pleased?

His most famous quotation is: "In the future, everybody will be world famous for fifteen minutes".

But his own fame has been much longer-lasting than that and while, even today, it is still controversial, it can surely never be described as boring?

*Andy Warhol loved to transform ordinary things into something fascinating – his "Shoes" are a perfect example of this. Trace off the shoe shapes, arrange and colour them to suit yourself for a smart but casual intarsia sweater. Full instructions are given in the Centre Section No. 14.*

*Graphics used as an art form, or on clothing, doesn't seem to lose popularity – especially with the young! The simple "Can" shape is worked in intarsia, the rest is swiss darned. Full instructions are given in the Centre Section No 10.*



# STEP-BY-STEP

## USING THE KNITLEADER

*There are many advantages of using the Knitleader. No written instructions are required, you don't have to go searching for yarn quoted in patterns – no more excuses for not using up all that yarn bought "on sale!" and you have acres of design freedom. Garment shapes can be used upright, or tilted to give different effects and intarsia pictures may be drawn onto the Knitleader Sheet eliminating the necessity for following complicated charts. The Knitleader may be used with the all the standard gauge machines (4.5mm) and the Chunky machines (9mm), this issue we are dealing with standard gauge machines.*

When using the Knitleader you do not have to match the given tension, as in the case of written instructions, where you are advised which yarn etc to use. The Knitleader is set to the measurements taken from your tension swatch. You must always knit a tension swatch before you start work, whether you are using the Knitleader or not. When using written instructions the designer advises the tension they feel is correct for the yarn. When using the Knitleader you are not restricted by yarn, however, you must decide the tension suitable for the yarn and design chosen. Sample the yarn by knitting a long piece changing the tension every 20 rows or so. Take the knitting off the machine, feel it and examine it very carefully. Some areas will be too loose for the yarn and some too tight. Imagine how the garment will look and feel knitted in each of the tensions and so decide which one will be best. It is really worth the time and effort it takes to get it exactly right. Once you have knitted your tension swatch, treat it in exactly the same way that you will ultimately treat your garment. If you intend to press, wash, or dry-clean your garment, do the same to the tension swatch. The larger the tension swatch you knit the more accurate a measurement you can take from it. We recommend that you work your tension swatch over 100 stitches and 100 rows adopting the following procedure:-

**STEP 1.** Using the chosen yarn, tension setting and stitch design, cast on over 100 needles across the centre of the needlebed. Knit 20 rows. Using Waste Yarn – of the same type and

weight, but a contrasting colour – knit 2 rows. Set the Row Counter to 000. Using the garment yarn knit 30 rows. Push forward the 21st needle each side of '0' letting the stitch slip behind the now open latch – these needles are shown on the Needle Position Indicator. Take two separate lengths of the Waste Yarn, and place them into the hooks of the needles. Holding the Waste Yarn, gently but firmly with one hand, pull the needle back so that the stitch slips over the now closed latch and the Waste Yarn forms a loop in place of the stitch.

**STEP 2.** Knit 30 rows. Using the contrast yarn knit 2 rows. Using the garment yarn, tension setting and stitch design, knit 20 rows and cast off. Now leave your tension swatch to settle – a good length of time is 24 hours. The tension swatch will more accurately represent the finished garment the longer you leave it. If you intend to press, wash or dry-clean the garment, now is the time to put it to the test!

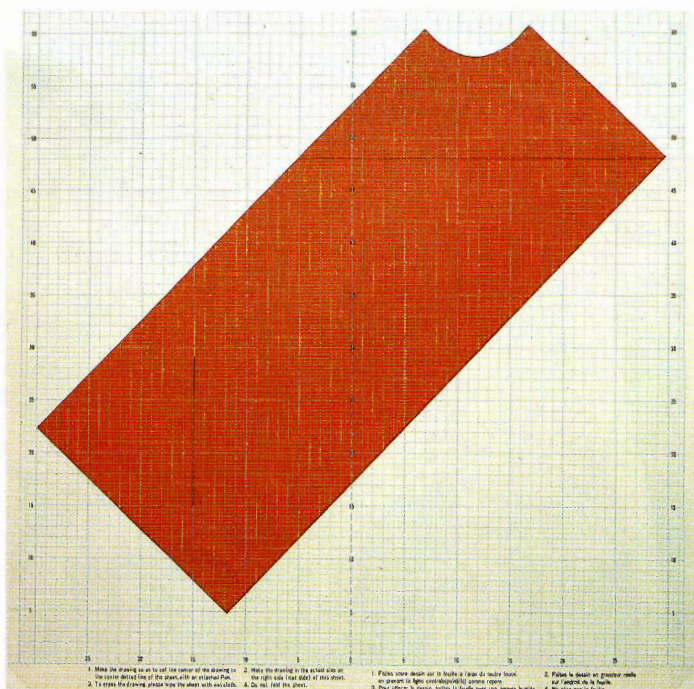

**STEP 3.** While your tension swatch is settling, use the time to prepare your garment shape and set up the Knitleader. Now draw the garment shape onto the Knitleader Sheet. We recommend that you make a paper pattern of all your garment shapes. This is an excellent way to store them and also allows you to use them in different ways, and/or adapt them easily. Our cardigan (see page 6) is an example of one of the design possibilities when using the Knitleader – the chevron yoke is achieved simply by placing the garment shape onto the Sheet at an angle and then knitting stripes!



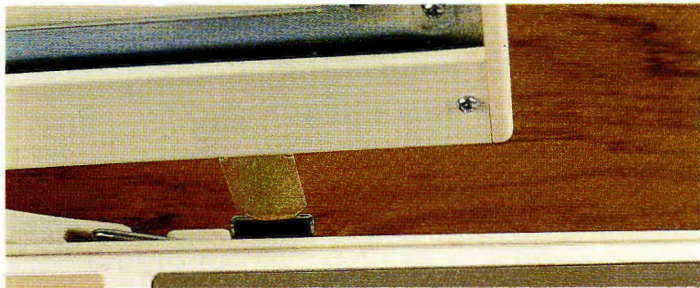

**STEP 4.** Take the Setting Plates and put them into their Holders underneath the Knitleader attachment. Drop the Setting Plates into the special Slots at the rear of the Knitting Machine.



**STEP 5.** Insert the Sheet Guides, one each to the left and right into the back of the Knitleader Attachment. Roll the Sheet, from top to bottom, shiny side inward. Place the Sheet inside the Sheet Guides. Taking the foot of the Sheet, pull it down gently, keeping it perfectly horizontal, and guide the perforations over the teeth of the wheel at the left. Using the Sheet Button at the right to adjust, insert the foot of the sheet into the Slit Opening running the length of the Knitleader. Use the Left Feeder Wheel, turning it clockwise, move the Sheet forward until the base line of the garment shape is level with the Slit Opening.



**STEP 6.** Take your tension swatch and using the ruler provided, on the purl side of the swatch, measure the distance between the two Waste Yarn loops – 40 stitches. Also measure the distance between the top and bottom two rows in Waste Yarn – 60 rows.

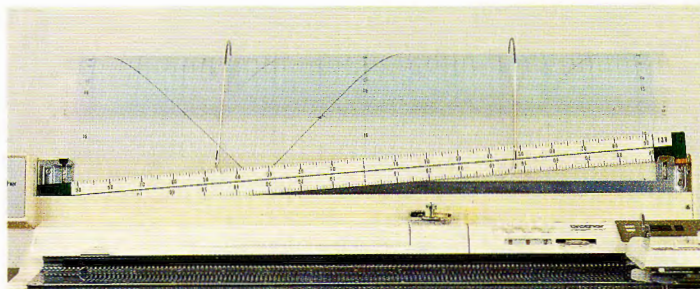

**STEP 7.** Using the 40 stitch measurement, select the appropriate Stitch Measure Scale – A Stitch Measure Scale Table appears on the outside of the Sheet Case. Place the selected Stitch Measure Scale into position.

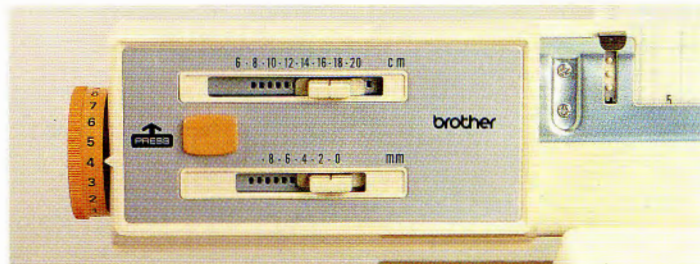

**STEP 8.** At the left of the Knitleader Attachment sits the Row Regulator. Depress the Clutch Button, using both the Centimetre Regulator (top) and the Millimetre Regulator (bottom) set to the 60 row measurement.

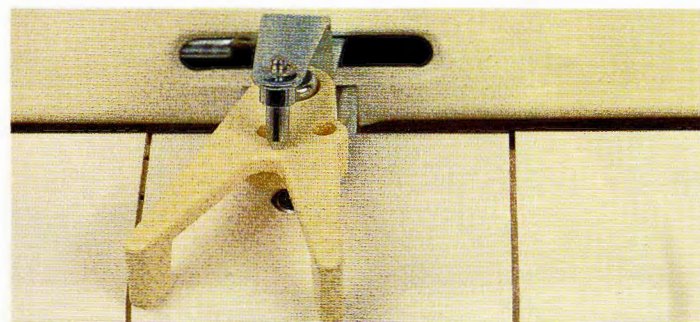

**STEP 9.** Slot the Feeding Lever into the left setting – 4.5mm gauge machine position. Set Knitleader Tripper on the left end of the Knitting Carriage to Working Position.



# SUMMER SELECTION

Once you have a basic garment shape in the correct size you can use it for practically any stitch. We have taken a simple round-neck classic shape and reproduced it using intarsia, single motifs, fairisle and striped stocking stitch. If you are using the Knitleader there is no reason why you cannot mix and match our design ideas to suit yourself.

*Left - use the "Eye" design given on Pattern Sheet No 10 and draw the circles and stripes as desired - full instructions are given in the Centre Section No 16.*

*Below - make a template of the "Jigsaw" shapes and place at random to create your own version of this wonderful sweater - full instructions are given in the Centre Section No 15.*

*Top right - "Windmill" single motifs in different colours transform a classic - full instructions are given in the Centre Section No 15.*







*Far right - a classic shape in simple stripes, a favourite with all - full instructions are to be found in the Centre Section No 15.*

*Right - a little more adventurous, here the front is worked in intarsia and the sleeves in fairisle. The round neck is worked by using the Holding Position facility then finished off with rib - full instructions are to be found in the Centre Section No 15.*





# STRIKING STRIPES

For a day at the coast choose nautical stripes in comfortable cotton. These garments may be knitted in stripes only, or just for fun, worked with intarsia animal shapes in reverse colours.







*Full instructions for the lady's sweater (far left) are to be found in the Centre Section No 17. Instructions for the boy's and girl's outfits are to be found in the Centre Section Nos 18 and 19.*



# *STITCH LIBRARY*

Select a design from the deep – intarsia or fairisle – using beads to decorate. Pattern Sheet references for stitch designs are as follows:-  
A- 7(B), B - 4(B), C - 10(B), D - 8(D), E - 4(C), F - 6(F), G - 8(C),  
H - 10(C and D).

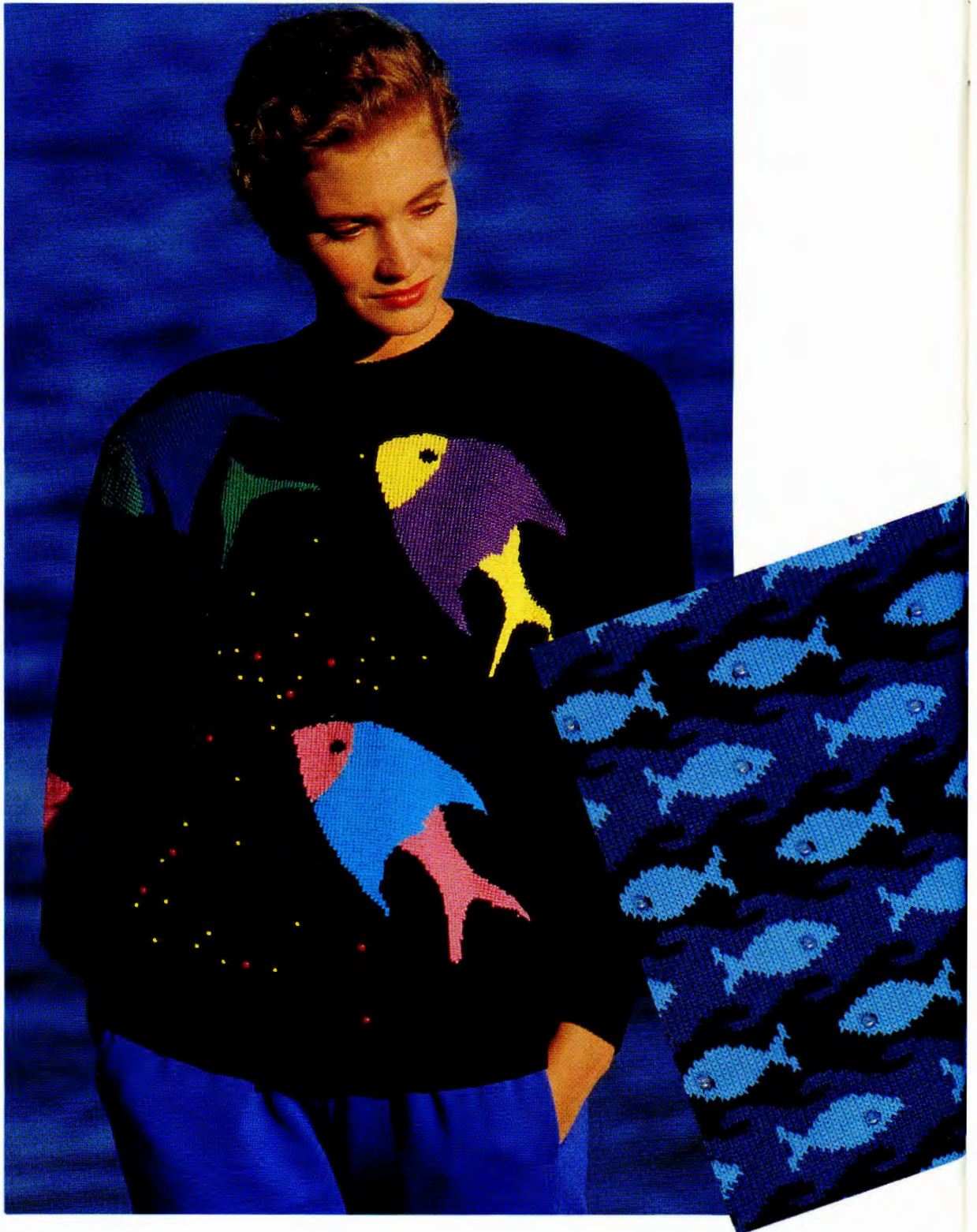



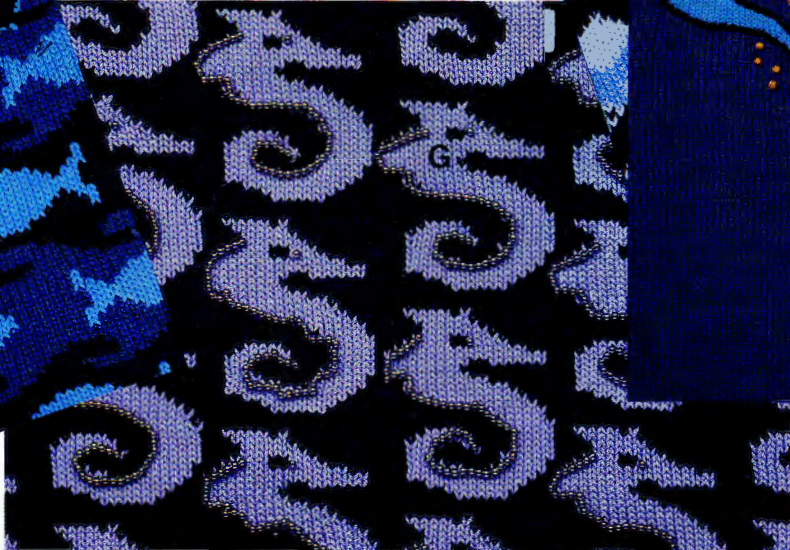
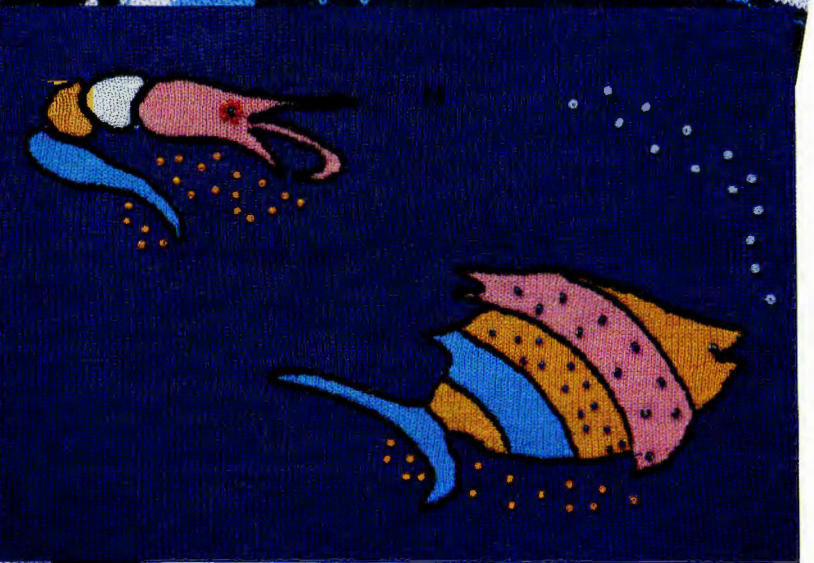
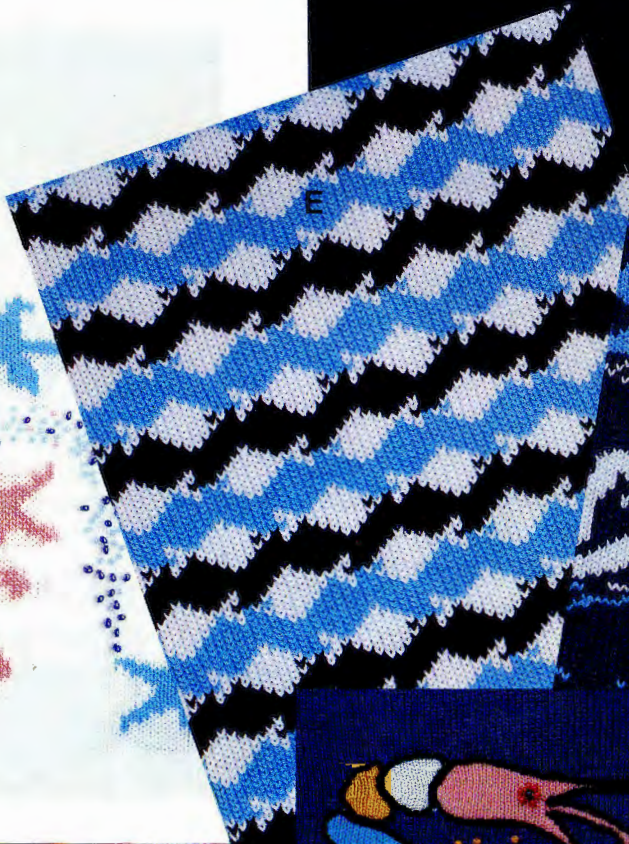
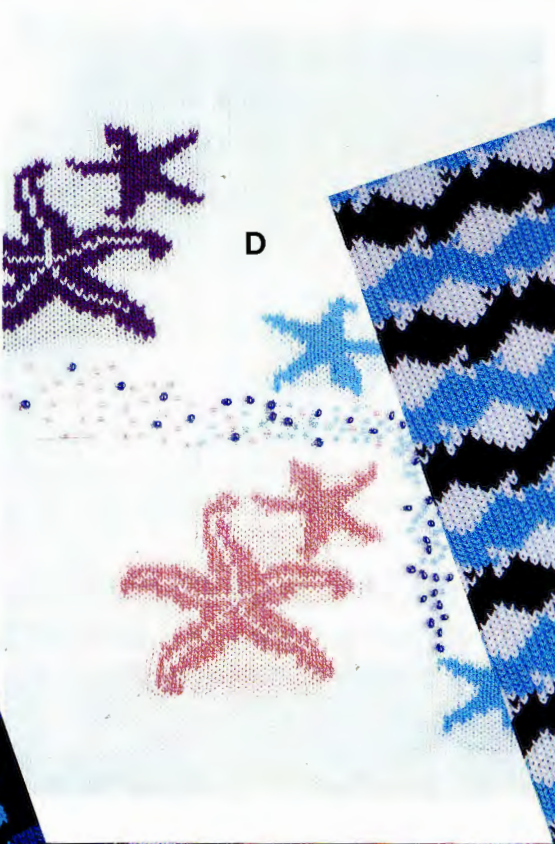
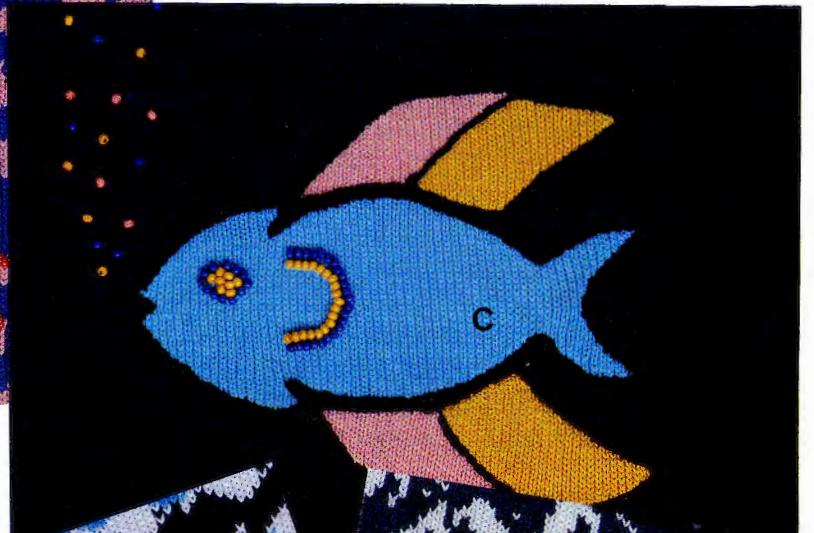



# STEP-BY-STEP

## BUTTONHOLES IN STOCKING STITCH STYLE A - (self neatens)

*This style of buttonhole is incorporated into a hem and has been used on the shoulder opening of the lady's sweater (see page 22). It can be used equally well on the front opening of a jacket, or cardigan, where a stocking stitch buttonhole band is wanted. The buttonholes are worked in two parts, one on each side of the hem, and are horizontal in relation to the knitting. The buttonholes are usually centred on the buttonhole band and so you must calculate their position before you start knitting - decide how wide (number of rows) you want the band to be.*

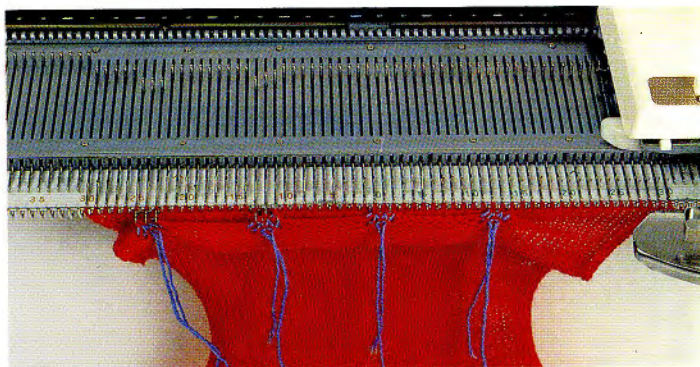

**STEP 3.** Take the needles back to Working Position one at a time, ensuring that the stitches in the hooks are pulled through the stitches behind the latches, to make one stitch.

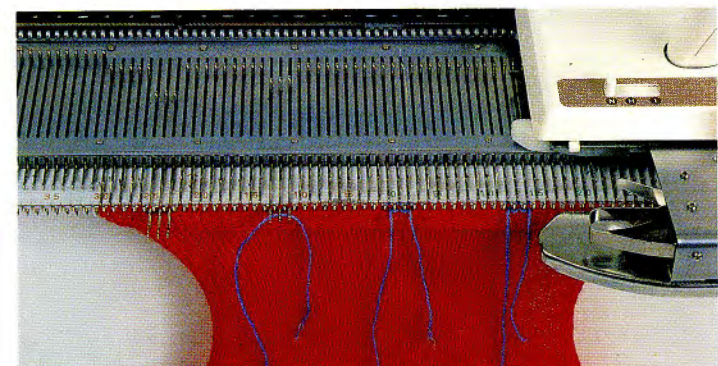

**STEP 1.** Knit to the row on which the buttonholes are to be positioned. Push into Holding Position all needles required for all the buttonholes, in our example we use groups of three. Using waste yarn knit the selected needles back by hand.

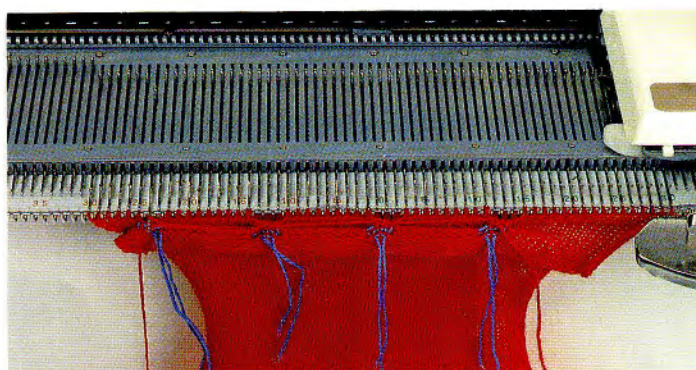

**STEP 4.** Using a separate length of main yarn, cast off each group of the newly formed stitches, leaving the empty needles in Working Position.

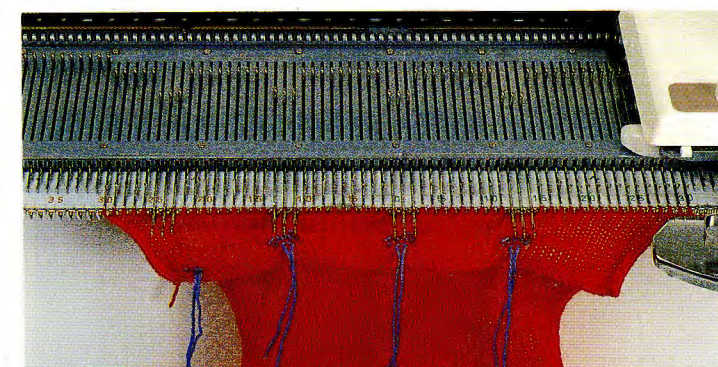

**STEP 2.** Knit to the foldline. Slacken the tension and knit 1 row, return to the working tension. Knit to the position of the second half of the buttonhole. Select the same groups of needles, pushing them towards Upper Working Position ensuring that the stitches slip behind the latches and the latches are left open. Pick up the three stitches from the row above the Waste Yarn and place them into the open hooks.

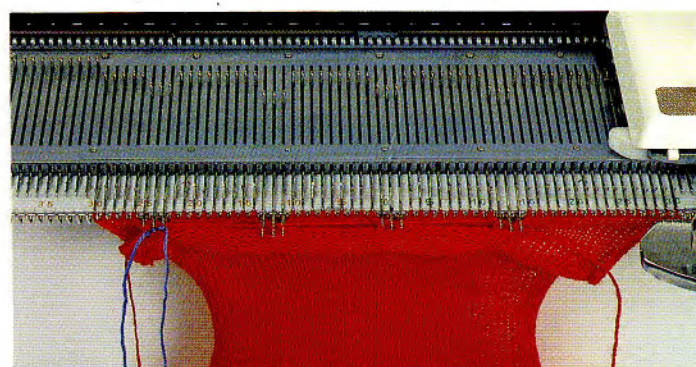

**STEP 5.** Pick up the stitches from below the Waste Yarn and place them onto the empty needles, removing the Waste Yarn.





**STEP 6.** Knit to complete the buttonhole band. At this point you have a choice as to how to finish off the buttonhole band:- a) pick up the first row of the band and place onto needles, slacken the tension, knit 1 row and cast off, b) cast off - this must then be stitched into position, or c) waste knit, then backstitch to garment through last row knitted in main yarn.



## STEP-BY-STEP

### BUTTONHOLES IN STOCKING STITCH STYLE B (neaten by hand)

Each finished buttonhole consists of two buttonholes made over two stitches and has been used on the jacket/jerkin (see page 4 and 5). They are horizontal in relation to the garment, one is made on the facing and one is made on the outside of the garment, both on the same row. When the facing is folded vertically into position the two buttonholes match up to form one buttonhole. When the garment is completed the buttonholes must be neaten. How you neaten them depends on the size of buttonhole and the thickness of the yarn. In this case we used a much thinner yarn and simply caught the two together matching up the buttonholes exactly.

This style of buttonhole may be over one, two or more stitches, however, if you are working them over more than two stitches you must use a separate length of yarn and cast off by hand at Step 1.



**STEP 1.** \*Knit to buttonhole row. Buttonhole stitches are transferred outward to their adjacent needles leaving the empty needles in Working Position.

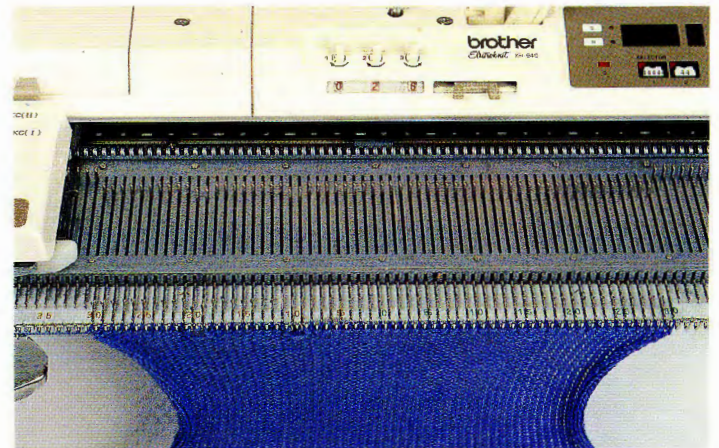

**STEP 2.** Knit one row. The stitches each side of the buttonhole have been knitted and the yarn is caught onto the empty needles.



**STEP 3.** Release the yarn caught on the empty needles. Using the single stitch Transfer Tool guide the loop around the empty needles to form an "e" wrap.\* Repeat from \* to \*.





*Full instructions for our  
patchwork cardigan are  
given in the Centre  
Section No 22.*



# PATCHWORK BRIGHTS!

Put some colour into your wardrobe! Simply by changing the background colour of each garment piece gives lots of scope for new design! The back of our fairisle cardigan (left) is knitted in two pieces to mimic the patchwork effect created by knitting the fronts and sleeves in different colourways. A variation on a theme is achieved by working Single Motifs on different coloured backgrounds.

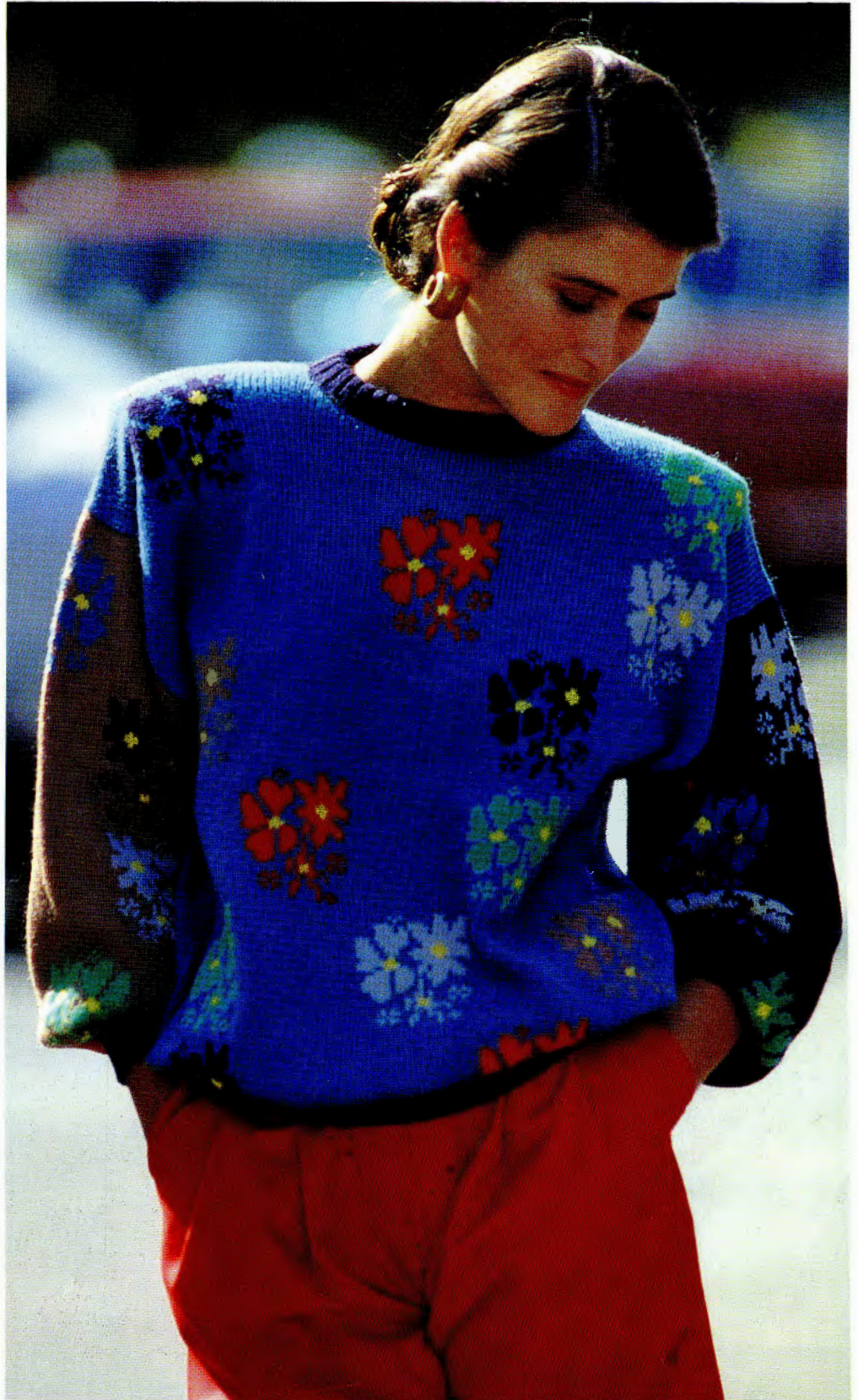

*Full instructions for our sweater are given in the Centre Section No 21.*