

brother fashion

Issue No. 10

UK £1.50

HFL 3.95

I £2.50

GARTER CARRIAGE

*This wonderful jacket
in practical cotton*

SIMPLY STOCKING STITCH

*Range of summer
garments to mix and
match with each other
or your favourite
wovens*

STITCH LIBRARY

*Exciting collection of
stitch patterns to use
for our waistcoats and
lined jackets.*

6 items for Standard
punchcard Machines!



brother



Dear Readers,

All of you are able to knit our mix and match summer collection - provided that you own a Standard gauge knitting machine. In lightweight viscose our summer pants, top, skirt, dress and tuck cardigan may be worn together or mixed with your favourite woven garments. This is an ideal opportunity to knit a garment to go with something you have in your wardrobe but have nothing to wear it with. The knitting of these garments is a piece of cake, but even so there are still a few things to remember when dealing with stocking stitch. It is always a good ideal to keep the speed you knit at even. Ensure that the yarn is free to move through the machines as the Knitting Carriage requires. If you knit too fast there is a tendency for the yarn to get caught up and it may alter the tension of the row you are knitting. When the garment is completed you will still see this row clearly against the others. So knit slowly, evenly and carefully. Remember this is a man-made fibre you are dealing with. Once pressed the yarn will inevitably stay that shape no matter how much you try to change it. Block and press ensuring that stitches are perfectly square.

The best way to do this is to make a paper pattern of the garment piece and pin the knitting to it before you block and press.

Happy Knitting,
Susan Nutbeam.

CONTENTS

WOMANSWEAR

- Garter Carriage Stitch Jacket, 3
- Fairisle lined jacket, 4
- Single motif lined jacket, 6
- Fairisle waistcoats, 8
- Chunky stocking stitch sweater, 10
- Stocking stitch pants, 14
- Tuck stitch longline cardigan, 14
- Stocking stitch sleeveless top, 16
- Stocking stitch panelled skirt, 18
- Stocking stitch panelled dress, 18

MENSWEAR

- Ribbed cardigan with zip front opening, 12

SPECIAL FEATURES

- Stitch Library, 22

LADY'S GARTER CARRIAGE STITCH JACKET

(Front Cover and opposite)

MACHINES: A, C or D with G-Carr. **MATERIALS:** YEO-MAN YARNS Cannele; A - 575 (600, 625, 650, 675)g (String) (100% cotton 350m/100g) 5 buttons. **MEASUREMENTS:** To fit bust 86 (91, 96, 101, 106)cm. **TENSION:** G-Carr Stitch Pattern - 40 sts = 14.3cm and 60 rows = 11.4cm (approx T7) after washing, blocking and pressing. **NOTES:** For G-Carr St Patt use Built-in No 420.

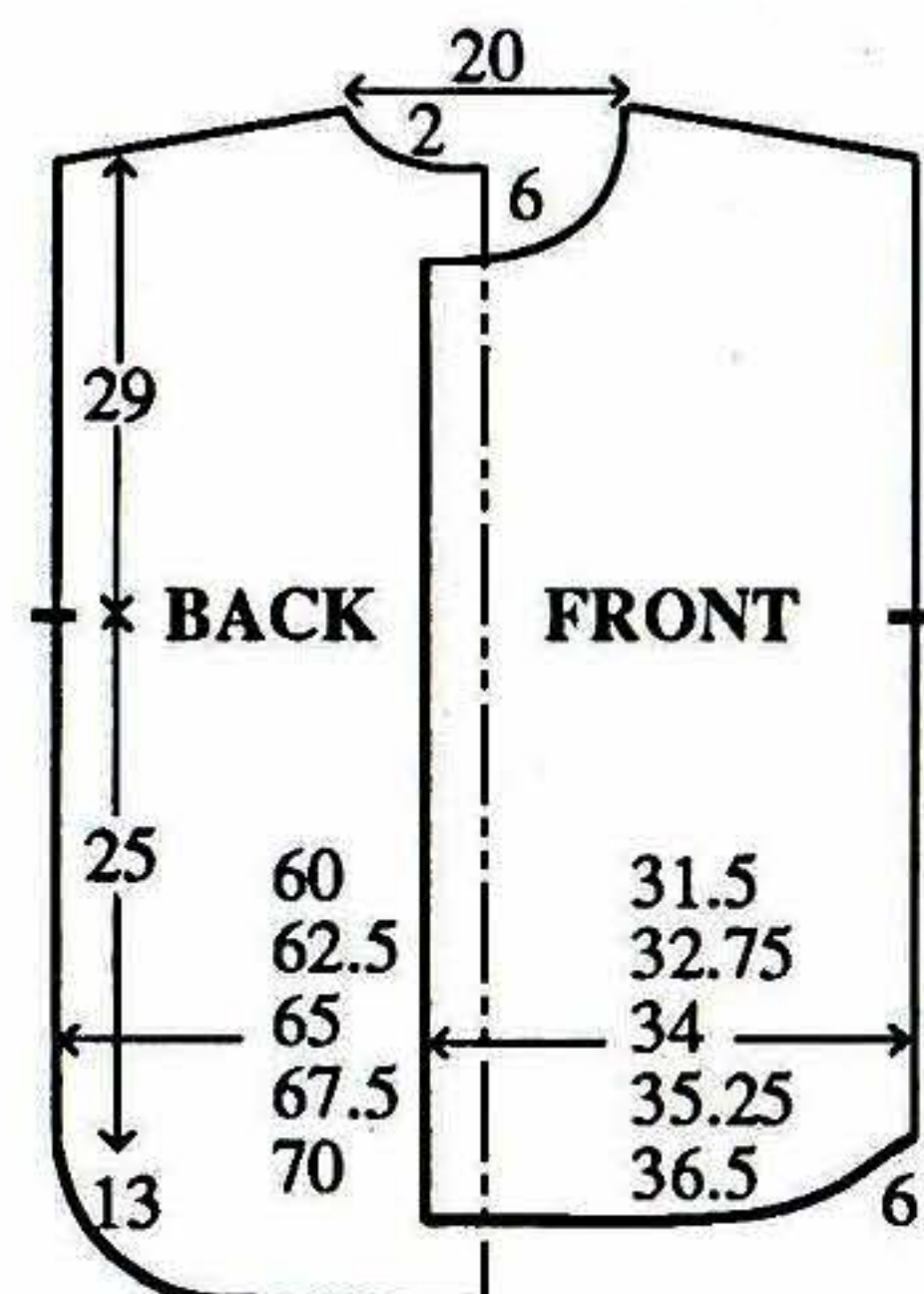

BACK

Using WY cast on over 169 (175, 183, 189, 197) KH Ns and knit a few rows. Using A COBH over these Ns, COL. Working in G-Carr St Pattern throughout, knit 1 row.....

Hem shaping

000. Leaving centre 67 (73, 81, 87, 95) Ns plus Ns at right in WP, using ravel cord knit back to NWP all Ns at left. Knit 1 row. Using ravel cord knit back to NWP all Ns at right of centre Ns. Knit 1 row. On side opposite G-Carr on next and

every foll row, bring back to WP 4 Ns x 4, 2 Ns x 22, 1 N x 42 [All Ns now in WP], 000. Knit to RC132. Place a WY marker at each end of work. Knit to RC284.

Shoulder shaping

At beg of next and every foll row cast off 3 sts x 24 (18, 10, 4, 0). 4 sts x 10 (16, 24, 30, 32) 6 sts x 0 (0, 0, 0, 2) and, AT THE SAME TIME at RC306.

Back neck shaping

Using ravel cord, take back to NWP centre 27 sts plus all sts at left. Knit 2 rows. On side opposite G-carr on next and every foll alt row take back to NWP 3 Ns x 5. Return Ns at left to WP and knit to match right side reversing shapings. Return sts for Back neck to Ns and using K-Carriage T10 knit 1 row and latch cast off.

RIGHT FRONT

Using WY cast on over 89 (93, 97, 101, 105) KH Ns and knit a few rows. Using A COBH over these Ns, 000.

Hem shaping

COL working in G-Carr St Pattern throughout, using ravel cord knit back to NWP 16 (20, 24, 28, 32) Ns at right. Knit 2 rows. On side opposite G-Carr on next and every foll alt row, bring back to WP 2 Ns x 0 (4, 8, 12, 16), 1 N x 16 (12, 8, 4, 0) [All Ns now in WP], 000. Knit to RC27. Work 1 x 5 st buttonhole, 6 sts from the left edge, on next and every foll 62nd row x 5 and, AT THE SAME TIME, at RC132. Place a WY marker at right end of work. Knit to RC283, COR.

Shoulder and Neck shaping

At beg of next and every foll alt row cast off 3 sts x 12 (9, 5,

2, 0), 4 sts x 5 (8, 12, 15, 16) 6 sts x 0 (0, 0, 0, 1) and, AT THE SAME TIME, at left on next and every foll alt row, using ravel cord take back to NWP 10 (11, 11, 12, 12) Ns x 1, 3 Ns x 2, 2 Ns x 3, 1 N x 11. Return sts for Front Neck to Ns and using K-Carr T10 knit 1 row and latch cast off.

LEFT FRONT

As RIGHT FRONT reversing shapings and omitting buttonholes.

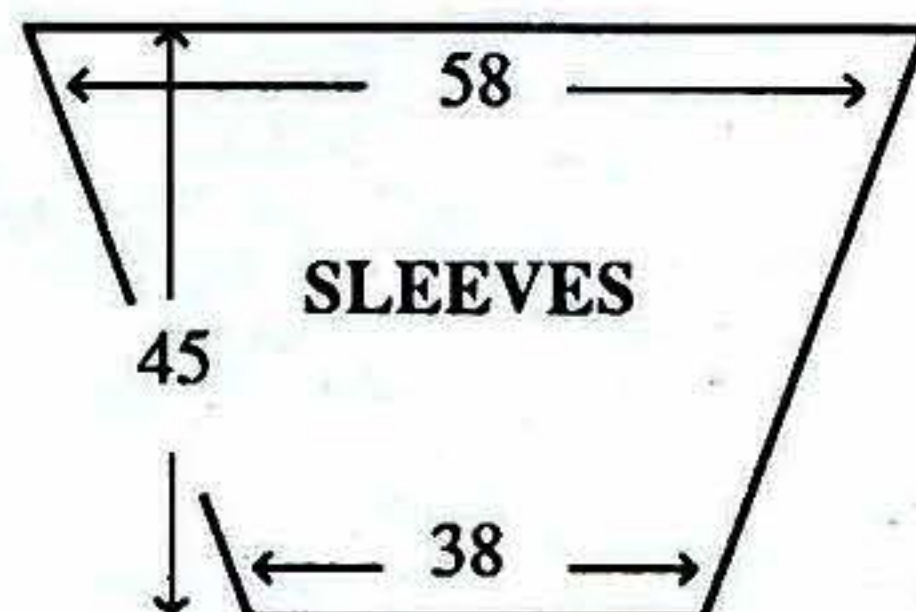

SLEEVES

Join both shoulders. Push 162 KH Ns to WP. With wrong side facing, pick up same number of sts evenly along armhole edge between WY markers and place onto Ns. Using K-Carr T7, knit 1 row from left to right, 000. Working in G-Carr St Pattern throughout, knit to RC16. Dec 1 st at each end of next and every foll 8th row x 28. Knit to RC235. T10 knit 1 row and latch cast off.

POCKETS (2)

Using A COBH over 45 KH Ns, 000. Working in G-Carr St Pattern throughout, knit to RC105. T10 knit 1 row and latch cast off. Stitch POCKETS to FRONTS as illustrated.

MAKE-UP

Work 1 row of Crochet along neck edge and hems. Wash, block and press. Join side and SLEEVE seams. Attach buttons.

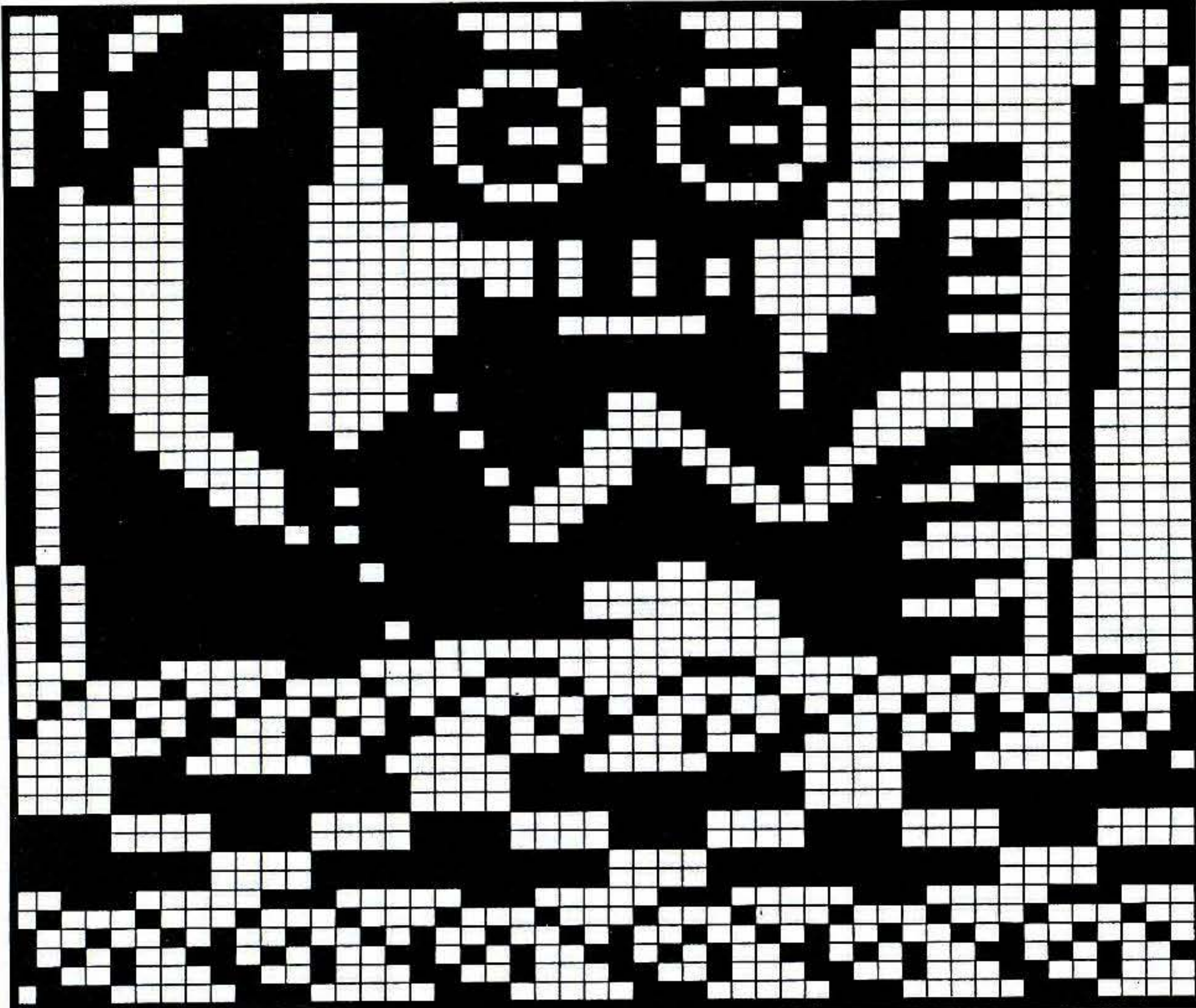

(179, 185, 193, 199)
 KH Ns. T7
 knit 1 row.
 Set for first row of Fairisle St Patt and knit 1 row to select Ns, 000.
 Working in Fairisle throughout (see NOTES), knit to RC156.
 Place a WY marker at each end of work. Knit to RC282***.

No 2 LADY'S LINED FAIRISLE JACKET

MACHINES: C or D.
MATERIALS: KING COLE Superspun Superwash 4-Ply wool; A - 235 (250, 265, 280, 305)g (Red 9), B (Mink 142) and C (Copper 109) - 140 (150, 160, 170, 180)g of each, D - 105 (115, 125, 135, 145)g (Wild Rose 118) and E - 90 (100, 110, 120, 130)g (Chocolate 23). (100% wool, 360m/100g). 4 buttons. Fabric.
MEASUREMENTS: To fit bust 86 (91, 96, 101, 106)cm.
TENSION: Fairisle St Patt - 40 sts = 14cm and 60 rows = 13.7cm (approx T7).
NOTES: Fairisle St Patt:-

FA	FB	No of Rows
***D	E	6
C	A	2

C	D	2
C	A	2
D	E	6**
A	B	34
Repeat from** to **		
A	C	34*
Repeat * to * throughout.		

BACK

***Using D COBH over 171

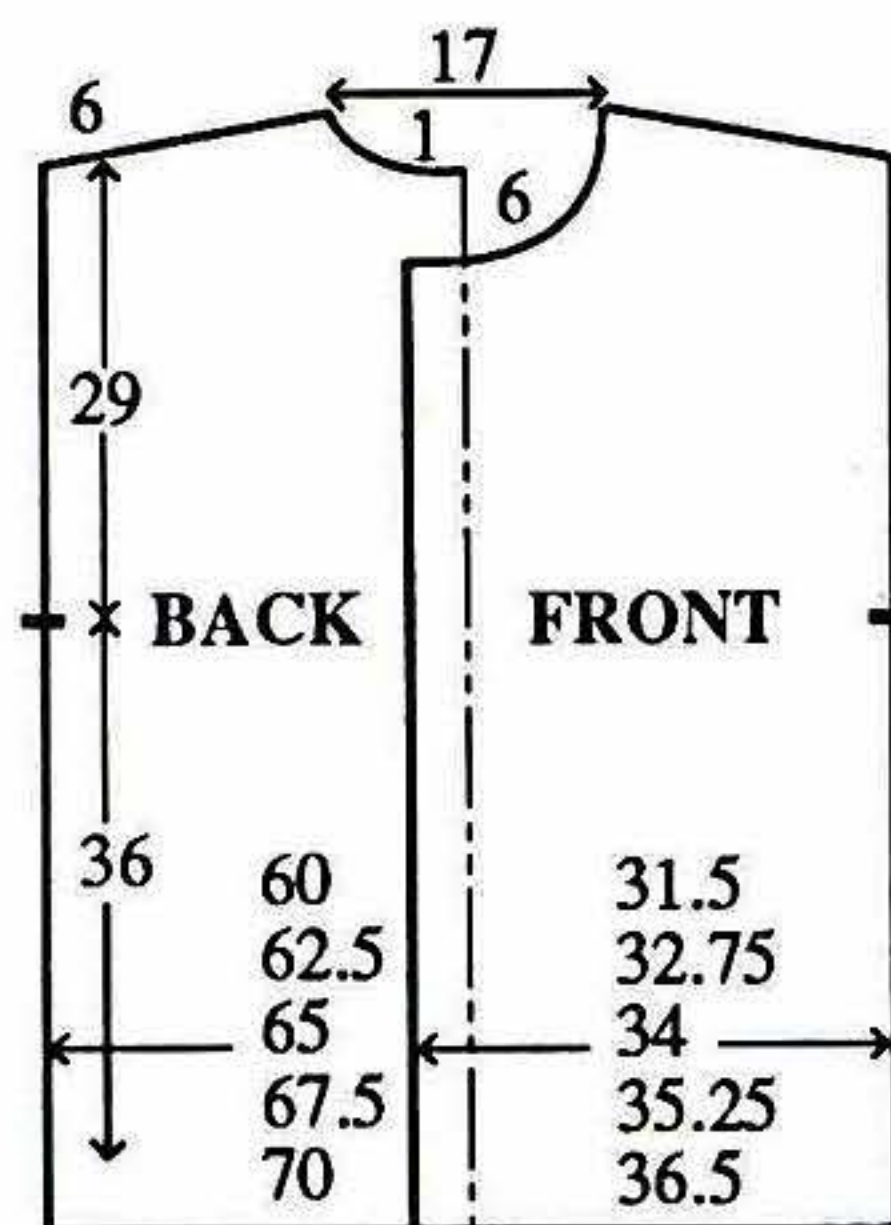

Shoulder shaping

At beg of next and every foll row cast off 4 (5, 5, 5, 6) sts x 24 (26, 24, 24, 24), 13 (0, 8, 12, 3) sts x 2 and, AT THE SAME TIME, at RC302.

Back neck shaping

Cast off centre 25 sts. Waste knit sts at left, COR. Knit 1 row. At beg of next and every foll alt row cast off 4 sts x 3. Return sts from left side to Ns and knit to match right side reversing shapings.

RIGHT FRONT

As BACK from *** to *** using 91 (95, 97, 101, 105) KH Ns and, AT THE SAME TIME, work 4 x 6 st buttonholes, 6 sts from left edge, starting at RC61 then every foll 52nd row.
Shoulder and Neck shaping
 At right shape armhole as BACK and, AT THE SAME



TIME, at left on alt rows, cast off 10 (10, 9, 9, 10) sts x 1, 4 sts x 1, 3 sts x 2, 2 sts x 3 then dec 1 st x 4.

LEFT FRONT

As **RIGHT FRONT** reversing shapings and omitting buttonholes.

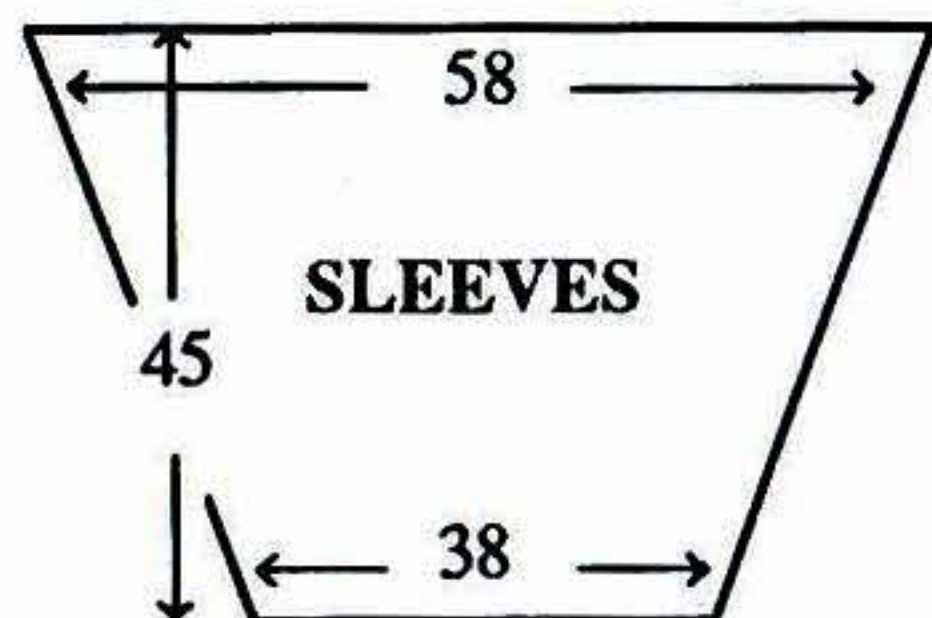

SLEEVES

Join both shoulders. Push 165 KH Ns to WP. With wrong side facing, pick up same number of sts evenly along armhole edge between WY markers and place onto Ns, COL. Set for 6th row of Fairisle St Patt - UPSIDE DOWN - and using D knit 1 row to select Ns, 000. Working in Fairisle throughout - in REVERSE order - knit to RC7. Dec 1 st at each end of next and every foll 7th row x 28. Knit to RC202. Using D knit 1 row. T10 knit 1 row and cast off.

POCKETS (2)

Using D COBH over 47 KH Ns. T7 knit 1 row. Set for first row of Fairisle St Patt and knit 1 row to select Ns, 000. Working in Fairisle throughout, knit to RC70. Using D knit 1 row. T10 knit 1 row and cast off.

MAKE-UP

Block and press all pieces. Join side and SLEEVE seams. Using diagram, make a paper pattern and cut out fabric allowing 1.5cm seam allowance. With right sides together, join fabric

to POCKETS on top edge and the two sides. Turn to right side and press. Attach to FRONTS as illustrated. Join shoulders. Set in SLEEVES. Join side and SLEEVE seams. Press seams open. Make buttonholes to correspond with buttonholes on garment. Press seam allowances on rem edges and stitch to garment. Neaten buttonholes. Attach buttons. Press.

No 3 LADY'S LINED JACKET WITH SINGLE MOTIF

MACHINES: D with FB100 - disk from this issue. **MATERIALS:** BRAMWELL YARNS 4-Ply acrylic; A - 345 (360, 375, 390, 405)g (Navy) and B - 100 (110, 120, 130, 140)g (White) (100% acrylic, 480m/100g). 4 buttons. **MEASUREMENTS:** To fit bust 86 (91, 96, 101, 106)cm. **TENSION:** St st - 40 sts = 14cm and 60 rows = 13.6cm (approx T6°). **NOTES:** Border Fairisle St Patt and Single Motif - A in FA and B in FB. See No 2 for garment diagram.

BACK

Using A COBH over 171 (179, 185, 193, 199) KH Ns. T6° knit 2 rows, 000. Knit 3 rows. Set for first row of Border Fairisle St Patt and knit 1 row to select Ns, 000. Working in Fairisle (see NOTES), knit to RC38. Using A and working in St st, knit to RC63. Set for first row of Single Motif and knit 1 row to select Ns. Work Motif for 200 rows and, AT THE SAME TIME, at RC158 place a WY marker at each end of work.

Knit to RC286.

Shoulder shapings

At beg of next and every foll row cast off 5 (5, 5, 5, 6) sts x 24 (26, 24, 24, 24), 2 (0, 8, 12, 3) sts x 2 and, AT THE SAME TIME, at RC306.....

Back neck shapings

Cast off centre 25 sts. Waste knit sts at left, COR. Knit 1 row. At beg of next and every foll alt row cast off 4 sts x 3. Return sts from left side to Ns and knit to match right side reversing shapings.

RIGHT FRONT

As **BACK** * to * using 91 (95, 97, 101, 105) KH Ns, knit to RC60. Work 1 x 6 st buttonhole, 6 sts from left edge on next and every foll 52nd row x 4 and, AT THE SAME TIME at RC158. Place a WY marker at right end of work. Knit to RC286.

Shoulder and Neck shapings

At right shape armhole as **BACK** and, AT THE SAME TIME, at left on alt rows, cast off 10 (10, 9, 9, 10) sts x 1, 4 sts x 1, 3 sts x 2, 2 sts x 3 then dec 1 st x 4.

LEFT FRONT

As **RIGHT FRONT** reversing shapings and omitting buttonholes.

SLEEVES

Join both shoulders. Push 165 KH Ns to WP. With wrong side facing, pick up same number of sts evenly along armhole edge between WY markers and place onto Ns, 000. Using A and working in St st, knit to RC2. Dec 1 st at each end of next and every foll 7th row x 28 and, AT



THE SAME TIME at RC159, set for first row of Border Fairisle St Patt and knit 1 row to select Ns. Working in Fairisle, knit 34 rows. Knit to RC199. T10 knit 1 row and cast off.

POCKETS (2)

Using A COBH over 47 KH Ns. T6° knit 2 rows, 000. Knit 3 rows. Set for first row of Border Fairisle St Patt and knit 1 row to select Ns. Working in Fairisle, knit 34 rows. Using A and working in St st knit to RC71. T10 knit 1 row and cast off.

MAKE-UP

Join side and SLEEVE seams. Using diagram, make a paper pattern and cut out fabric allowing 1.5cm seam allowance. With right sides together, join fabric to POCKETS on top edge and the two sides. Turn to right side and press. Attach to FRONTS as illustrated. Join shoulders. Set in SLEEVES. Join side and SLEEVE seams. Press seams open. Make buttonholes to correspond with buttonholes on garment. Press seam allowances on rem edges and stitch to garment. Neaten buttonholes. Attach buttons.

No 4 LADY'S WAISTCOATS

MACHINES: [1] A, C or D [2] C or D. **MATERIALS:** Standard 4 ply wool, we used KING COLE Superspun Superwash 4-Ply wool; [1] FLOWERS - A - 100(115, 130, 145, 160)g (Larkspur 13), B (African Violet 136), C (Turquoise 16) and D (Mink 142) - 45 (50, 55, 60, 65)g of each [2] CROCODILE - A - 60

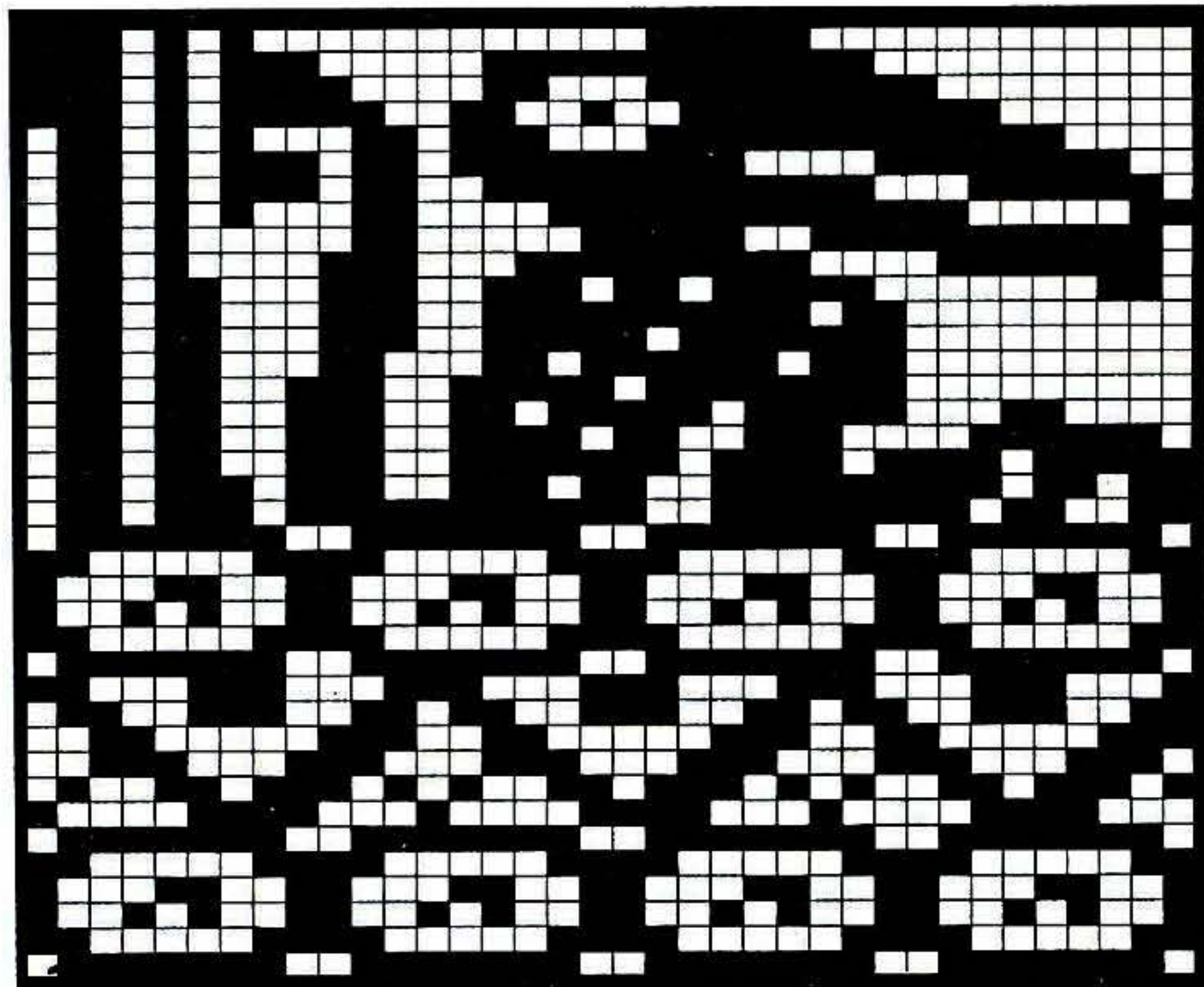

(70, 80, 90, 100)g (Olive 69), B (Copper 109), C (Aran 22) - 50 (55, 60, 65, 70)g of each and D - 90 (100, 110, 120, 130)g (Chocolate 23) (100% wool, 360m/100g). 4 buttons. Fabric for lining. **MEASUREMENTS:** To fit bust 86 (91, 96,

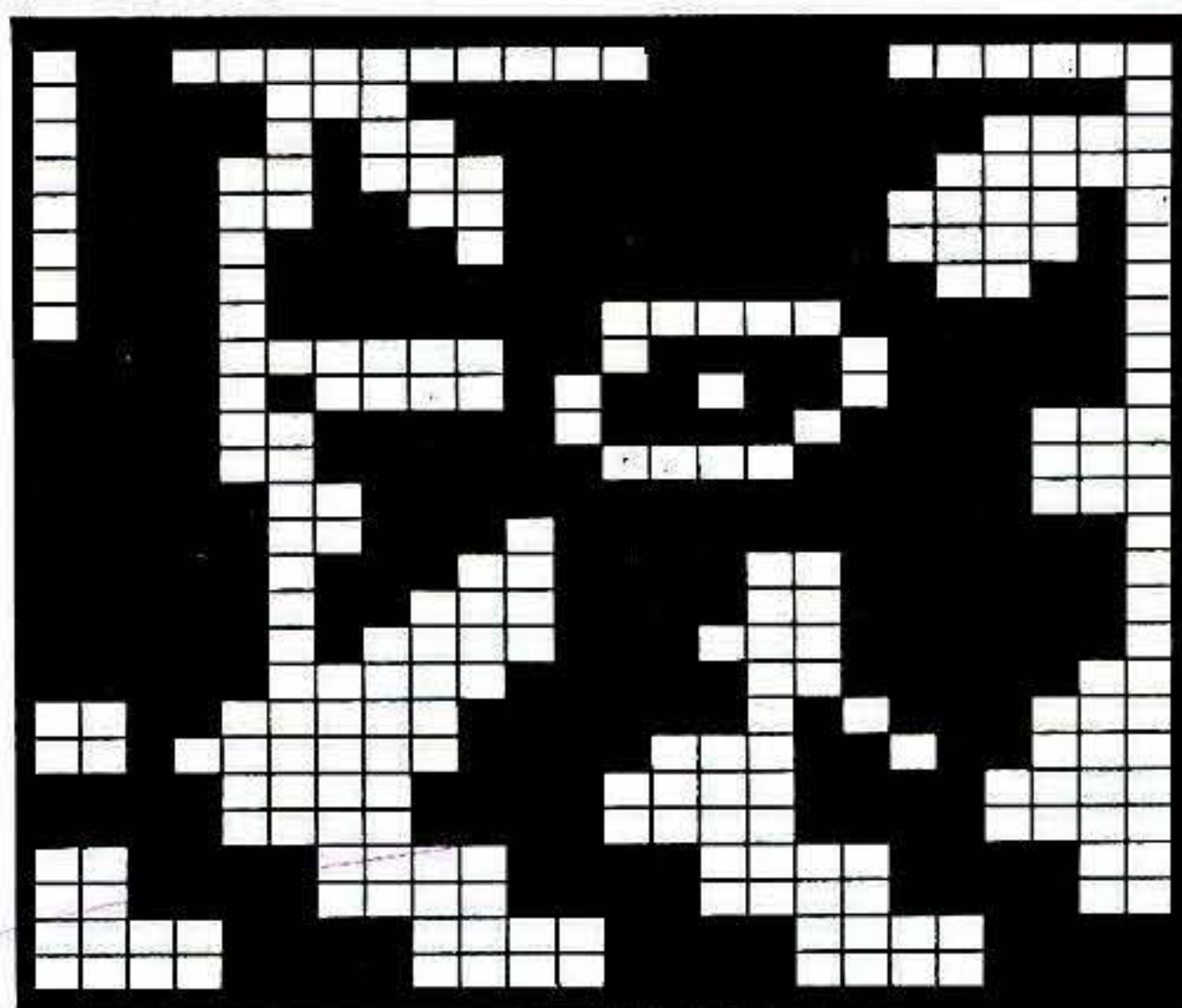

101, 106)cm. **TENSION:** Fairisle St Patts - 40 sts - 12.3cm and 60 rows = 14.1cm (approx T6). **NOTES:** Fairisle St Patt [1] - A in FA throughout, knit 6 rows B, 20 rows C, 6 rows D, 20 rows B, 6 rows C, 20 rows D in FB. [2]: -

FA	FB	No of rows
A	C	6
A	D	6
A	C	6
A	D	20
B	C	6
B	D	6
B	C	6
B	D	20

BACK

Using A COBH over 157 (165, 173, 181, 189) KH Ns. T6 knit 1 row. Set for first row of Fairisle St Patt and knit 1 row to select Ns, 000. Working in Fairisle throughout (see NOTES), knit to RC110 (116, 116, 120, 120).

Armhole shaping

At beg of next and every foll row cast off 4 sts x 2, 3 sts x 4, 2 sts x 4, then dec 1 st at each end of alt rows x 6. Knit to RC204 (210, 214, 218, 222). Waste knit 31 (35, 39, 43, 47) sts at each end of work for



shoulders. On rem 55 sts, using A T6 knit 1 row. T10 knit 1 row and cast off.

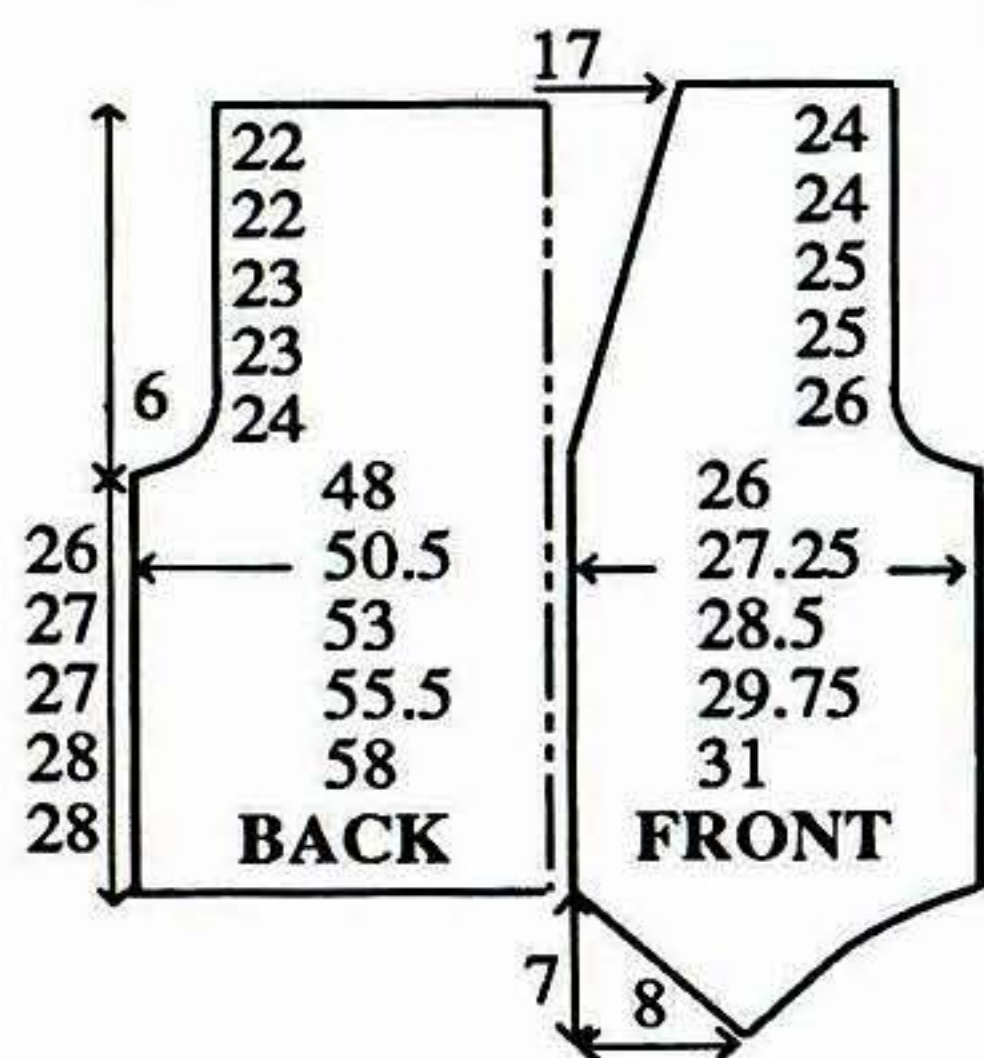

RIGHT FRONT

Using A COBH over 3 KH Ns. T6 knit 1 row. Set for [1] 23rd row [9th row of Fairisle St patt and knit 1 row to selct Ns, 000. Working in Fairisle throughout, at right on next and every foll alt row cast on 3 sts x 10 (6, 2, 0, 0), 4 sts x 6 (10, 14, 14, 10), 5 sts x 0(0, 0, 2, 6) and AT THE SAME TIME, at left, cast on 2 sts x 12, 1 st x 4 [RC30 85(89, 93, 97, 101) sts], 000. Knit to RC10. At left, work 1 x 5 st buttonhole, 6 sts from

edge, on next and every foll 30th(32nd, 32nd 33rd, 33rd) row x 4. Knit to RC110 (116, 116, 120, 120).

Armhole and Neck shaping

At right shape armhole as BACK and, AT THE SAME TIME, at left dec 1 st on next and every foll 3rd row x 34. Knit to RC212 (218, 222, 226, 230) and waste knit rem 31 (35, 39, 43, 47) sts.

LEFT FRONT

As RIGHT FRONT reversing shapings and omitting buttonholes.

MAKE UP

Join both shoulders by placing both sets of shoulder sts back onto Ns with right sides together. T10 knit 1 row and cast off. Block and press. Join side seams. Using diagram make paper pattern and cut out fabric allowing 1.5cm seam allowance. Join shoulders and side seams. Press seams open. Make buttonholes to correspond with buttonholes on garment. Press seam allowances on rem edges and stitch to garment. Neaten buttonholes. Attach buttons. Press.

No 5 LADY'S CHUNKY STOCKING STITCH SWEATER

MACHINES: B1, B2 or B3.
MATERIALS: YEOMAN YARNS Cittadella; A - 550 (570, 590, 610, 630)g (Gold) (100% viscose 240m/100g).
MEASUREMENTS: To fit bust 86 (91, 96, 101, 106)cm.
TENSION: 20 sts = 11.3cm and 30 rows = 7.9cm (approx T1).





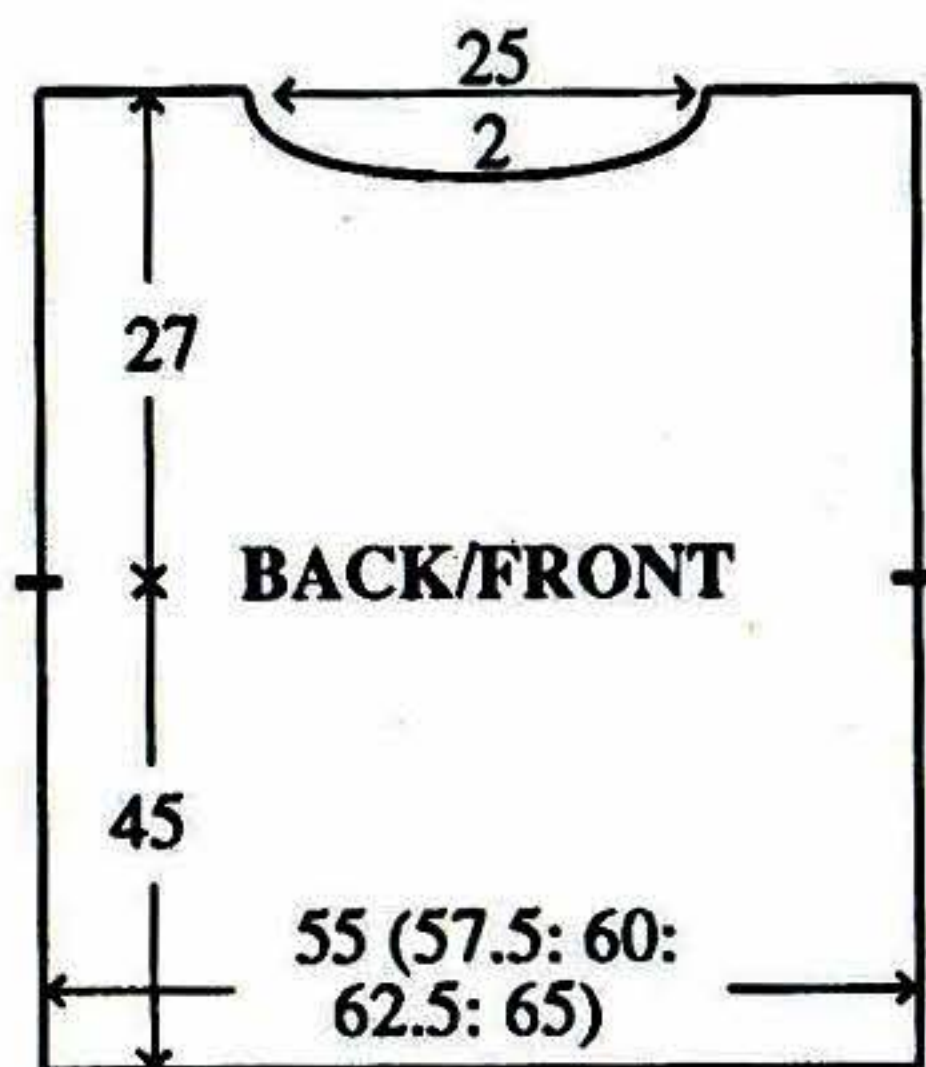

BACK/FRONT

Using A COBH over 97 (101, 105, 109, 113) KH Ns, 000. Working in St st throughout, knit to RC170. Place a WY marker at each end of work. Knit to RC264.

Neck shaping

Push into HP centre 21 Ns plus all Ns at left. *Always taking yarn round inside N, knit 2 rows. **At left, bring forward to HP 3 Ns, knit 2 rows**. Repeat from ** to ** x 4 and waste knit rem 26 (28, 30, 32, 34) sts*, COL. Keeping centre 21 Ns plus all Ns at right in HP, repeat from * to * reading right as left, COL. T10 knit 1 row over rem 45 sts and latch cast off.

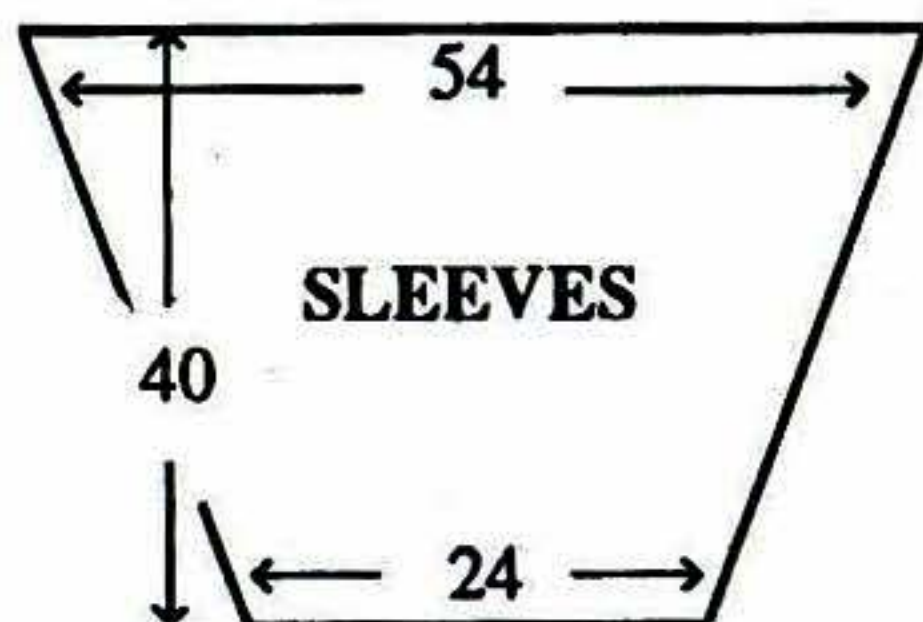

SLEEVES

Join both shoulders by placing both sets of shoulder sts back onto Ns with right sides together. Using A T10 knit 1 row and cast off. Push 95 KH Ns to WP. With wrong side facing, pick up same number of sts evenly along armhole edge between WY markers and place

onto Ns, 000. Using A knit to RC20. Dec 1 st at each end of next and every foll 5th row x 26. Knit to RC151. T10 knit 1 row and latch cast off.

MAKE-UP

Block and press. Join side and SLEEVE seams.

No 6 MAN'S RIBBED ZIP FRONTED JACKET

MACHINES: A, C or D with KR. **MATERIALS:** SHETLAND 4-PLY, we used JAMIESON and SMITH 2-Ply Jumper weight; A - 570 (590, 610, 630, 650)g (Purple/Wine Mix FC55) (100% shetland wool 280m/100g). 1 x 55cm zipper. **MEASUREMENTS:** To fit chest 91 (96, 101, 106, 111)cm. **TENSION:** Rib St Patt - 40 sts = 17.4cm and 60 rows = 15cm (approx T8/2). **RIB:** 1 x 1 T2/2. **NOTES:** Rib St Patt - Pitch H, all Ns on KH in WP, 1 x 1 Ns on KR in WP, set for Half-Fisherman's Rib. Cable St Patt - * **On KR, cable 1 x 1 over end 2 Ns at FRONT edge. Knit 8 rows**. Repeat from ** to **. * Repeat from * to * to end cabling 2 extra KR Ns every 16 rows.

BACK

Using A cast on over 139 (145, 151, 157, 163) KH Ns as RIB, 000. Knit to RC14. Trans to Rib St Patt, 000. Working in Rib St Patt throughout (see NOTES), knit to RC176.

Armhole shaping

At beg of next and every foll row, cast off 3 sts x 2, 2 sts x 6, then dec 1 st at each end of alt rows x 7. Knit to RC276 (280,

284, 288, 292). Trans all sts to KH. T8 knit 1 row. Waste knit centre 35 sts. Waste knit rem 36 (39, 42, 45, 48) sts at each end of work for shoulders.

POCKET BAGS (2)

Using A COBH over 29 KH Ns, 000. T8 knit to RC90 and waste knit.

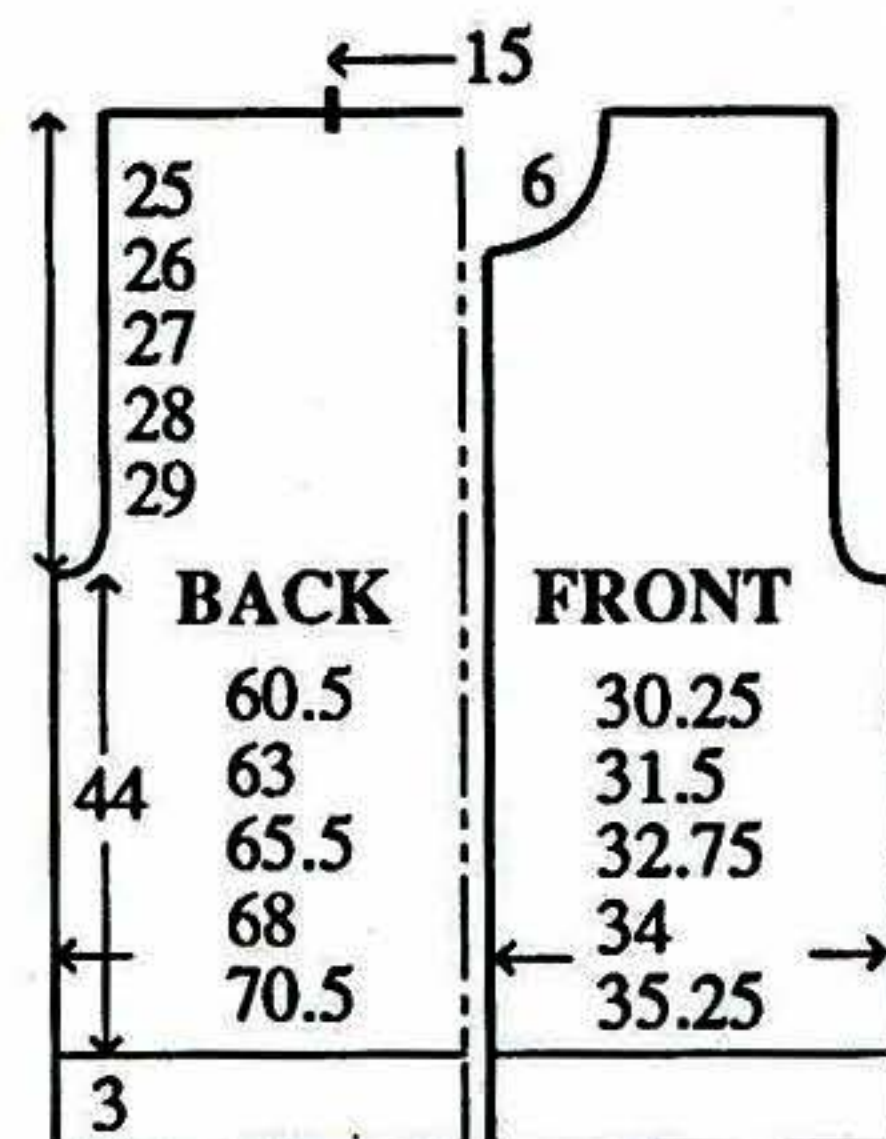

LEFT FRONT

Using A cast on over 71 (73, 77, 79, 81) KH Ns as RIB, 000. Knit to RC14. Trans to Rib St Patt, 000. Working in Rib St Patt throughout, knit to RC48.

Place Pocket Bag

Waste knit centre 29 sts. With wrong side facing, place sts from POCKET BAG onto Ns. Trans these sts to N Arrangement of Rib St Patt, RC48. Knit to RC136. Work Cable St Patt (see NOTES) to end, knit to RC176.

Armhole shaping

At beg of next and every foll alt row cast off 3 sts x 1, 2 sts x 3, then dec 1 st x 7. Knit to RC259 (263, 267, 271, 275).

Neck shaping

At beg of next and every foll alt row cast off 4 sts x 1, 3 sts x 2, 2 sts x 2, then dec 1 st x 5 (4, 5, 4, 3). Knit to RC284 (288, 292, 296, 300). Trans all sts to KH. T8 knit 1 row and waste



knit rem 36 (39, 42, 45, 48) sts.

RIGHT FRONT

As LEFT FRONT reversing shapings.

POCKET RIBS

Push 31 KH Ns to WP. With right side facing, place 29 sts from Pocket opening onto centre 29 Ns. Trans to RIB, 000. Knit to RC9. T10/8 knit 1 row. Trans all sts to KH and latch cast off. Stitch cast on edge of POCKET BAG to RIB. Stitch side edges of POCKET BAGS together. Stitch side edges of RIB to garment.

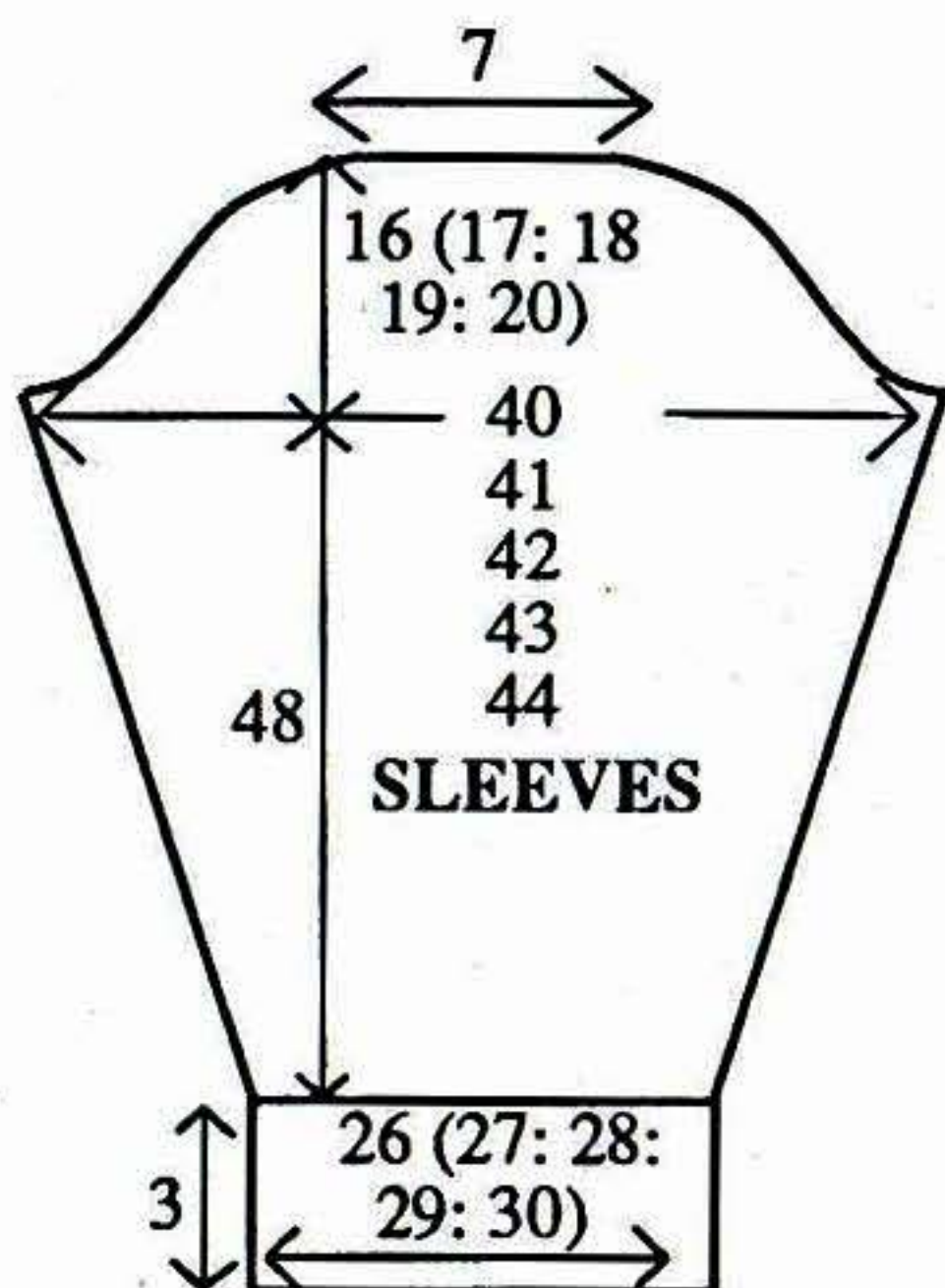

SLEEVES

Using A cast on over 61 (63, 65, 67, 69) KH Ns as RIB, 000. Knit to RC14. Trans to Rib St Patt, 000. Working in Rib St Patt throughout, knit to RC6. Inc 1 st at each end of next and every foll 12th row x 16. Knit to RC192.

Sleeve Head shaping

At beg of next and every foll row cast off 3 sts x 2, 2 sts x 4, then dec 1 st at each end of alt rows x 27 (28, 29, 30, 31). Cast off 2 sts at beg of next 4 rows. Cast off rem 17 sts.

COLLAR

Join both shoulders by placing both sets of shoulder sts back onto Ns with right sides together. T10 knit 1 row and cast off. Using A cast on over 76 KH Ns as FNR, 000. T2/2 knit to RC32. Trans all sts to KH. T8 knit 1 row. With right side facing, pick up same number of sts evenly along neck edge and place onto Ns. T10 knit 1 row and cast off.

MAKE-UP

Block and lightly press. Set in SLEEVES. Join side and SLEEVE seams. Work crochet along FRONT opening edges and sew in zipper.

No 7 LADY'S ONE SIZE TROUSERS

MACHINES: A, C or D. **MATERIALS:** YEOMAN YARNS Janeiro; A - 320g (Navy) (50% viscose, 25% linen, 25% acrylic. 750m/100g). Elastic. **MEASUREMENTS:** One size to fit up to hip 111cm. **TENSION:** St st - 40 sts = 14.5cm and 60 rows = 9cm (approx T2).

RIGHT LEG

Using WY cast on over 200 KH Ns and knit a few rows ending with COR. Using A T4 knit 1 row. T1 knit 7 rows. T8 knit 1 row. T1 knit 8 rows. Turn up hem. T2 knit 1 row, 000. Working in St st throughout, knit to RC432 (adjust length here).

Crotch shaping

Cast off 4 sts at beg of next 2 rows. Dec 1 st at each end of

next and every foll alt rows x 8. Knit to RC610.

Back Waist shaping

At left, on next and every foll alt row, push into HP 87 Ns x 1, 8 Ns x 9. T8 knit 1 row over all sts. **WAISTBAND:** T2 knit 34 rows. T10 knit 1 row and latch cast off.

LEFT LEG

As RIGHT LEG reversing shaping.

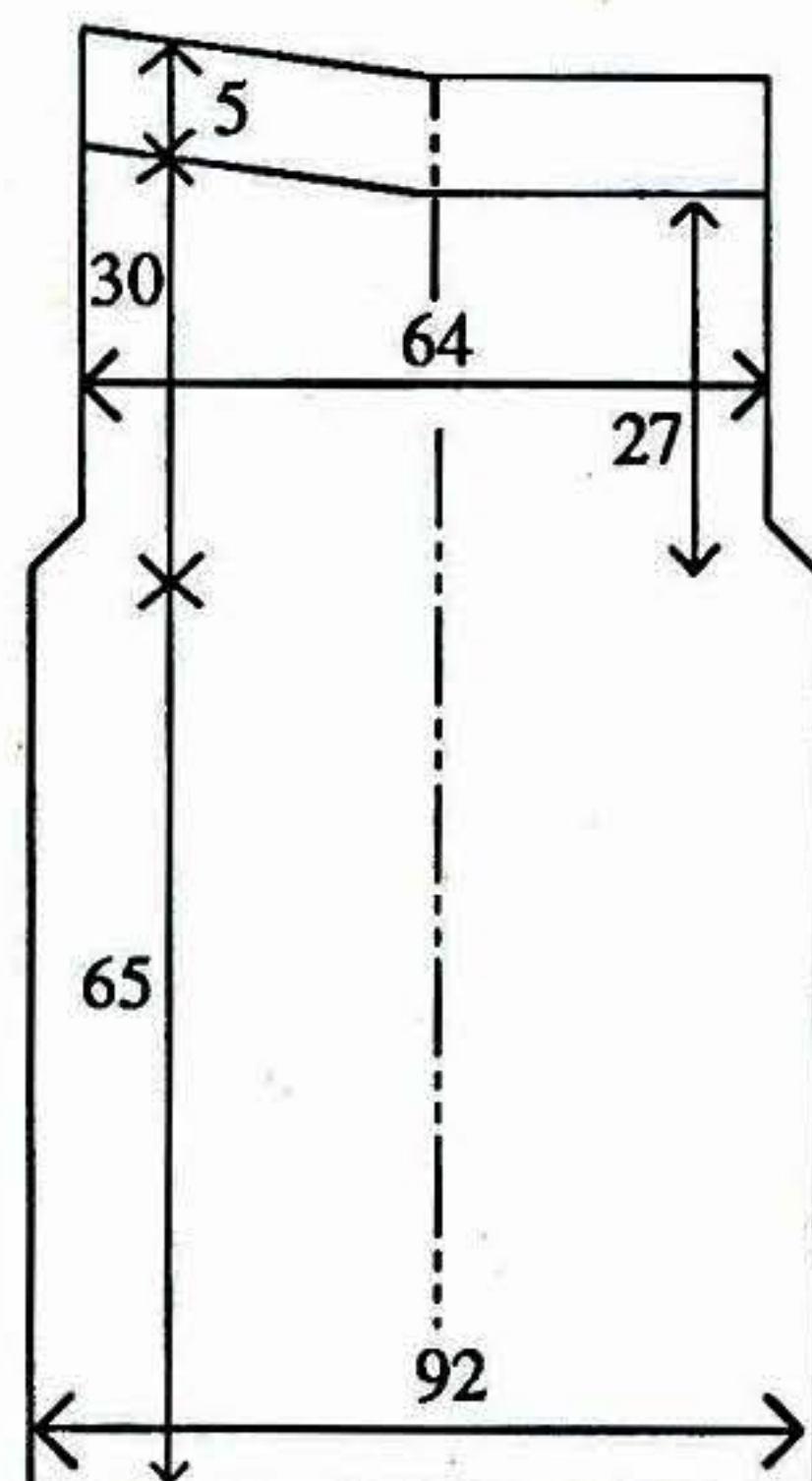

MAKE-UP

Block and press. Join FRONT/BACK seams. Join inside LEG seams. Fold WAISTBAND in half to inside and stitch down loosely encasing elastic.

No 7 LADY'S TUCK STITCH LONG LINE CARDIGAN

MACHINES: A, C or D. **MATERIALS:** YEOMAN YARNS Janeiro; A - 350 (360, 370, 380, 390)g (Sienna) (50% viscose, 25% linen, 25% acrylic 750m/100g). 6 small



buttons. **MEASUREMENTS:** To fit bust 86(91, 96, 101, 106)cm. **TENSION:** Tuck St Patt - 40 sts = 16.5cm and 60 rows = 7cm (approx T3). **NOTES:** For Tuck St Patt use Built-in No 289. Purl side is used as the right side of garment. When shaping all Ns are counted as sts throughout. Tuck St Patt N arrangement:-

0
| | | | | | | | | | | | | | | |

BACK

Using WY cast on over 143 (151, 159, 167, 175) KH Ns and knit a few rows ending with COR. Using A T4 knit 1 row. T2 knit 5 rows. T10 knit 1 row. T2 knit 5 rows. T4 knit 1 row. Turn up hem. Set for first row of Tuck St Patt. T3 knit 1 row to select Ns. Trans to N Arrangement, 000. Working in Tuck throughout, knit to RC626. Place a WY marker at each end of work. Knit to RC847. Knit 1 row St st. Waste knit centre 43 sts. Waste knit rem 50 (54, 58, 62, 66) sts at each end of work for shoulders.

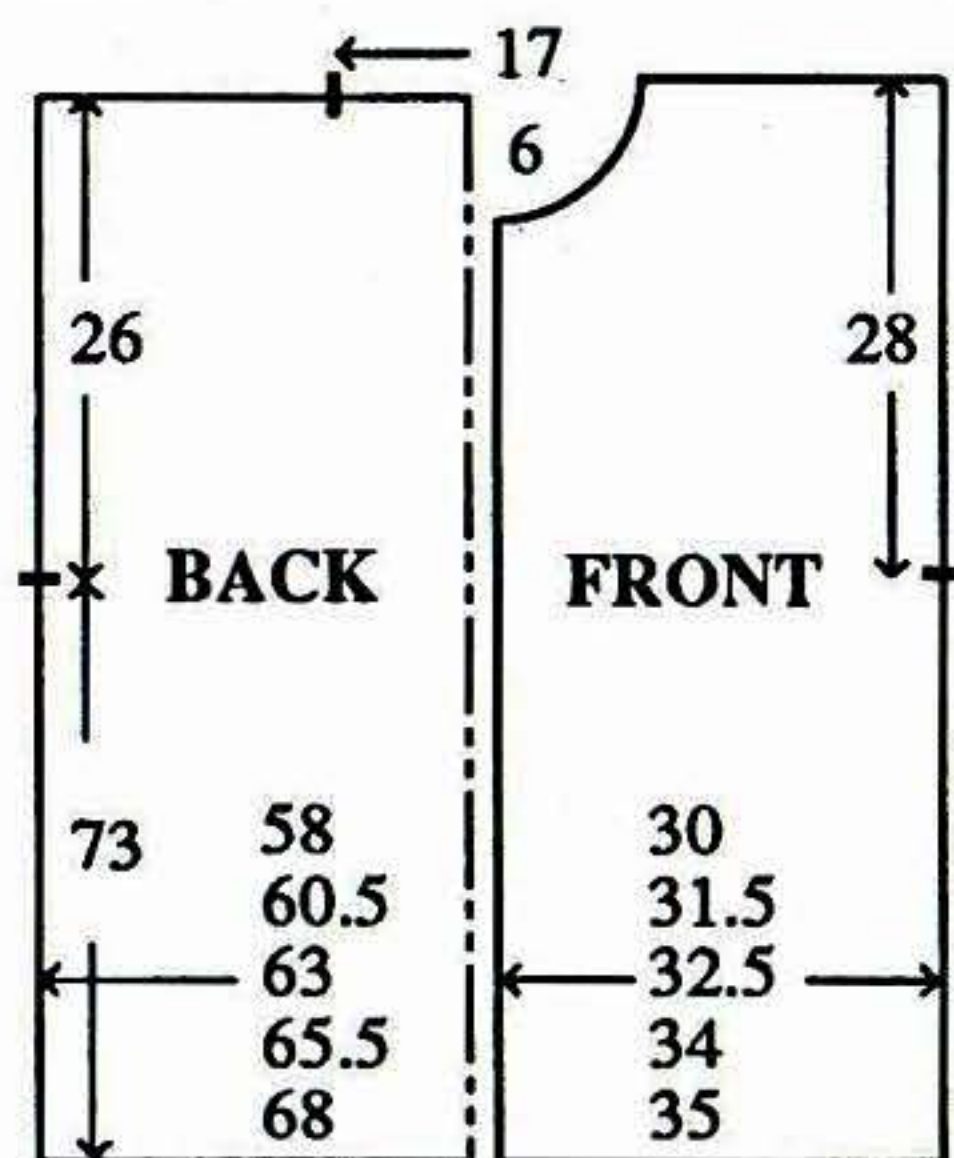

RIGHT FRONT

As BACK * to * using 75 (79, 83, 87, 91) KH Ns. Place a WY

marker at left end of work. Knit to RC814.

Neck shaping

At beg of next and every foll 4th row, cast off 5 sts x 1, 3 sts x 2, 2 sts x 4, then dec 1 st x 6. Knit to RC865. Set for st st and knit 1 row. With wrong side facing, place sts from Right BACK shoulder onto Ns. T4 knit 1 row. T10 knit 1 row and backstitch cast off.

LEFT FRONT

As RIGHT FRONT reversing shaping.

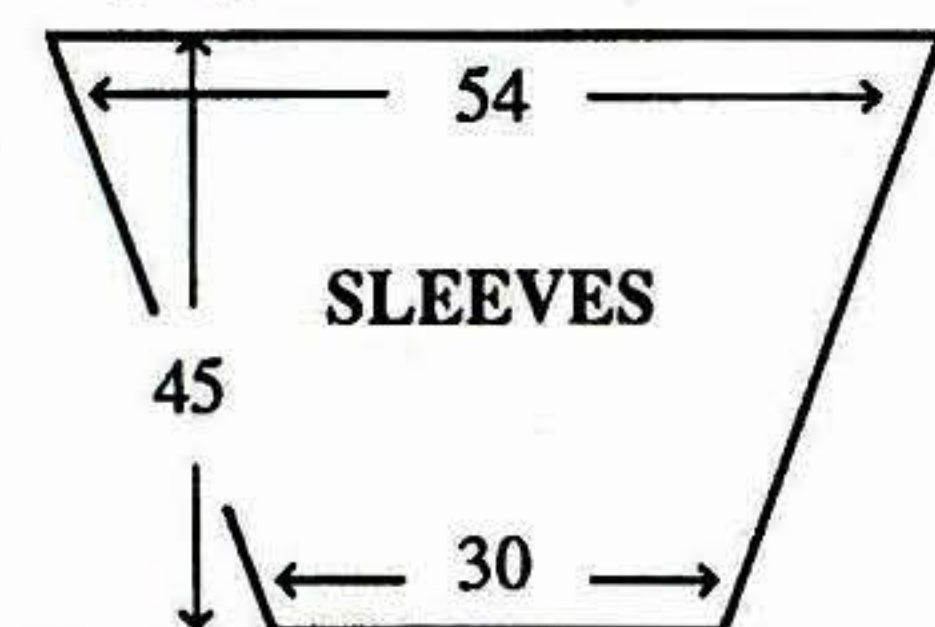

SLEEVES

Push 131 KH Ns to WP. With right side facing, pick up same number of sts evenly along armhole edge between WY markers and place onto Ns, COL. Set for first row of Tuck St Patt and using A T3 knit 1 row to select Ns. Trans to N Arrangement, 000. Working in Tuck throughout, knit to RC36. Dec 1 st at each end of next and every foll 12th row x 29. Knit to RC385. Set for st st and knit 1 row. Waste knit rem 73 sts. **CUFFS:** With wrong side facing, return sts to Ns. Push all Ns into WP. T4 knit 1 row. T2 knit 5 rows. T10 knit 1 row. T2 knit 5 rows. T4 knit 1 row. Pick up sts from first row of CUFF and place onto Ns. Knit 1 row. T10 knit 1 row and cast off.

NECKTRIM

Using WY cast on over 103

KH Ns and knit a few rows ending with COR. Using A T4 knit 1 row. T2 knit 5 rows. T10 knit 1 row. T2 knit 5 rows. T4 knit 1 row. Turn up hem and knit 1 row. With wrong side facing, pick up same number of sts evenly along neck edge and place onto Ns. Knit 1 row. T10 knit 1 row and latch cast off.

MAKE-UP

Work crochet along FRONT opening edges. Block and press. Join side and SLEEVE seams. Press seams. Attach buttons.

NO 8 LADY'S SLEEVELESS TOP

MACHINES: A, C or D. **MATERIALS:** YEOMAN YARNS Janeiro; A - 100 (110, 120, 130, 140)g (Oxford) (50% viscose, 25% linen, 25% acrylic 750m/100g). **MEASUREMENTS:** To fit bust (86, 91, 96, 101, 106)cm. **TENSION:** St st - 40 sts = 14.5cm and 60 rows = 9cm (approx T2).

BACK/FRONT

Using WY cast on over 125 (133, 139, 147, 153) KH Ns and knit a few rows ending with COR. Using A T4 knit 1 row. T1 knit 7 rows. T10 knit 1 row. T1 knit 7 rows. T4 knit 1 row. Turn up hem. T2 knit 1 row, 000. Working in St st throughout, knit to RC214.

Armhole shaping

Cast off 4 sts at beg of next 2 rows. Knit 1 row. Dec 1 st at each end of next and every foll 3rd row x 20. Knit to RC294 (300, 306, 312, 318).



Neck shaping

Waste knit centre 19 sts. Waste knit sts at left, COR. Knit 1 row. Dec 1 st at beg of next and every foll alt row x 10 then every foll 4th row x 4. Knit to RC334 (340, 346, 352, 358) and waste knit rem 15 (19, 22, 26, 29) sts. Return sts at left to Ns and knit to match right side reversing shaping.

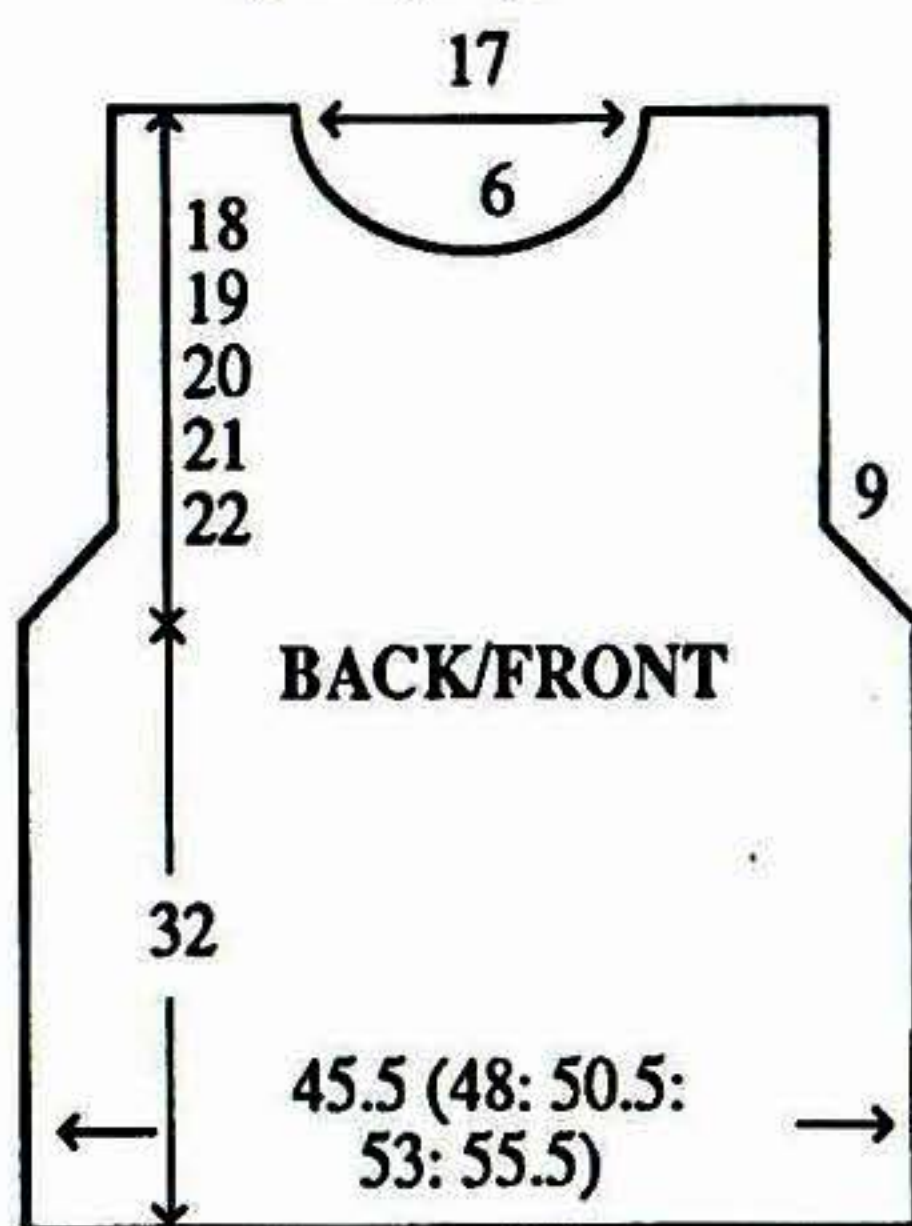

NECKTRIM

Join one shoulder by placing one set of shoulder sts back onto Ns with right sides together. T10 knit 1 row and cast off. Push 150 KH Ns to WP. With wrong side facing, pick up same number of sts evenly along neck edge and place onto Ns. T2 knit 8 rows. T10 knit 1 row. T2 knit 8 rows. T10 knit 1 row and latch cast off. Join second shoulder as first. Join NECKTRIM seam and fold in half to inside and stitch down loosely.

ARMBANDS

As NECKTRIM using 144 (150, 156, 162, 168) KH Ns.

MAKE-UP

Block and press. Join side seams. Press seams.

No 9 PANELLED

SKIRT

MACHINES: A, C or D.
MATERIALS: YEOMAN YARNS Janeiro; A - 415 (425, 435, 445, 455)g (Conifer) (50% viscose, 25% linen, 25% acrylic 750m-/100g). Elastic to fit waist + 2.5cm. **MEASUREMENTS:** To fit hip 91 (96, 101, 106, 111)cm. **TENSION:** St st - 40 sts = 14.5cm and 60 rows = 9cm (approx T2).

SKIRT PANEL (6)

Using WY cast on over 191 (193, 195, 197, 199) KH Ns and knit a few rows ending with COR. Using A T4 knit 1 row. T1 knit 7 rows. T8 knit 1 row. T1 knit 8 rows. Turn up hem. T2 knit 1 row. Working in St st throughout.

Hem shaping

On side opposite K-Carr, on next 2 rows, push into HP 73 KH Ns. On side opposite K-Carr, take back to UWP 8 KH Ns x 18, 000. Knit to RC4. Dec 1 st at each end of next and every foll 4th row x 56, then every foll 13th row x 17. On rem 45 (47, 49, 51, 53) KH Ns, knit to RC580. **WAISTBAND:** T10 knit 1 row. T2 knit 41 rows. Pick up sts from first row of WAISTBAND and place onto Ns. T4 knit 1 row. T10 knit 1 row and cast off loosely.

MAKE-UP

Block and press. Join seams. Thread elastic through WAISTBAND and join.

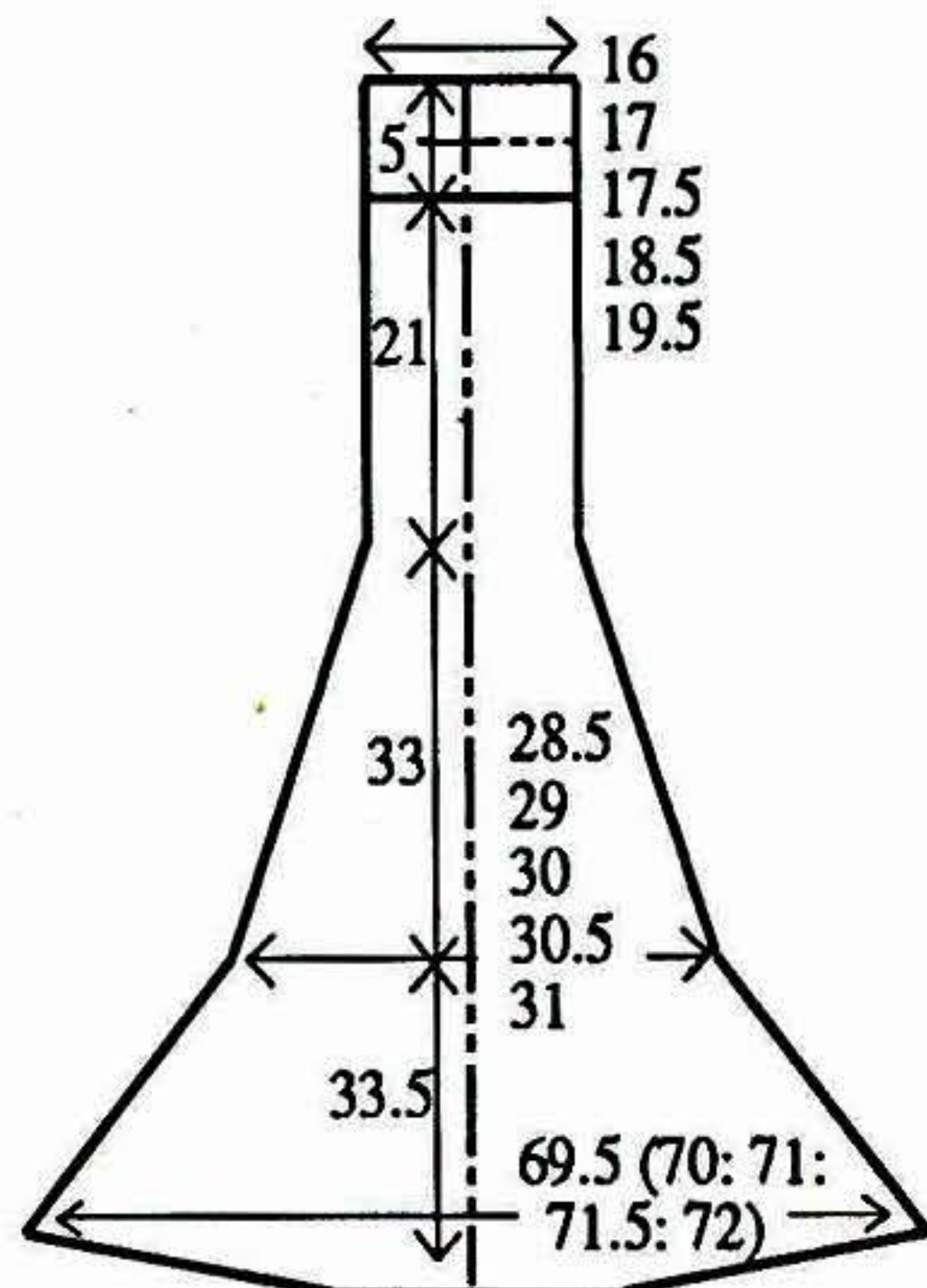

No 10 LADY'S DRESS

MACHINES: A, C or D.
MATERIALS: YEOMAN YARNS Janeiro; A - 260 (270, 280, 290, 300)g (Oxford) (50% viscose, 25% linen, 25% acrylic. 750m/100g). **MEASUREMENTS:** To fit bust 86 (91, 96, 101, 106)cm. **TENSION:** St st - 40 sts = 14.5cm and 60 rows = 9cm (approx T2).

BACK/FRONT CENTRE PANEL

Using WY cast on over 61 KH Ns and knit a few rows ending with COR. Using A T4 knit 1 row. T1 knit 7 rows. T8 knit 1 row. T1 knit 8 rows. Turn up hem. T2 knit 1 row, 000. Working in St st throughout, knit to RC416 (adjust length here). Dec 1 st at each end of next and every foll 19th row x 7 [RC530, 47sts]. Knit 8 rows. Inc 1 st at each end of next and every foll 8th row x 25 and, AT THE SAME TIME, at RC710.



Neck shaping

Waste knit centre 17 sts. Waste knit sts at left, COR. Knit 1 row. At beg of next and every foll alt row cast off 4 sts x 1, 3 sts x 1, then cast off 2 sts x 2 every foll 4th row, then dec 1 st x 8 every 4th row, and, AT THE SAME TIME, at RC736, place a WY marker at right end and dec 1 st at right on next and every foll 16th row x 5. Knit to RC810.

Shoulder shaping

Cast off 2 sts at beg of next and every foll alt row x 8. Return sts at left to Ns and knit to match right side reversing shapings.

outside and backstitch to garment through last row knitted in A.

FRONT RIGHT SIDE PANEL

Repeat from * to * using 39 (42, 45, 48, 51) KH Ns. Dec 1 st at each end of next and every foll 28th row x 5. Knit to RC530. Knit 20 rows. At right, inc 1 st on next and every foll 20th x 6 and, AT THE SAME TIME at left, inc 1 st on next and every foll 20th row x 5. Knit 4 rows. At left, dec 1 st on next and every foll 4th row x 24 and AT THE SAME TIME at RC674....

Armhole shaping

COR, at beg of next and every foll alt row, cast off 3 sts x 1 (1, 2, 2, 3), 2 sts x 1 (2, 2, 3, 3) then dec 1 st every foll 4th row x 8 (9, 9, 10, 10). Knit to RC730 and cast off rem 3 sts.

FRONT LEFT SIDE PANEL
As RIGHT SIDE PANEL reversing shapings. Stitch PANELS to FRONT.

BACK LEFT SIDE PANEL
Repeat from ** to **. Knit 16 rows. At left, dec 1 st on next and every foll 10th row x 19 and, AT THE SAME TIME at RC550, at right, inc 1 st on next and every foll 20th row x 6. Knit to RC674.

Armhole shaping
As FRONT SIDE PANEL. Knit to RC736 and cast off rem 3 sts.

BACK RIGHT SIDE PANEL
As LEFT SIDE PANEL reversing shapings. Stitch PANELS to BACK.

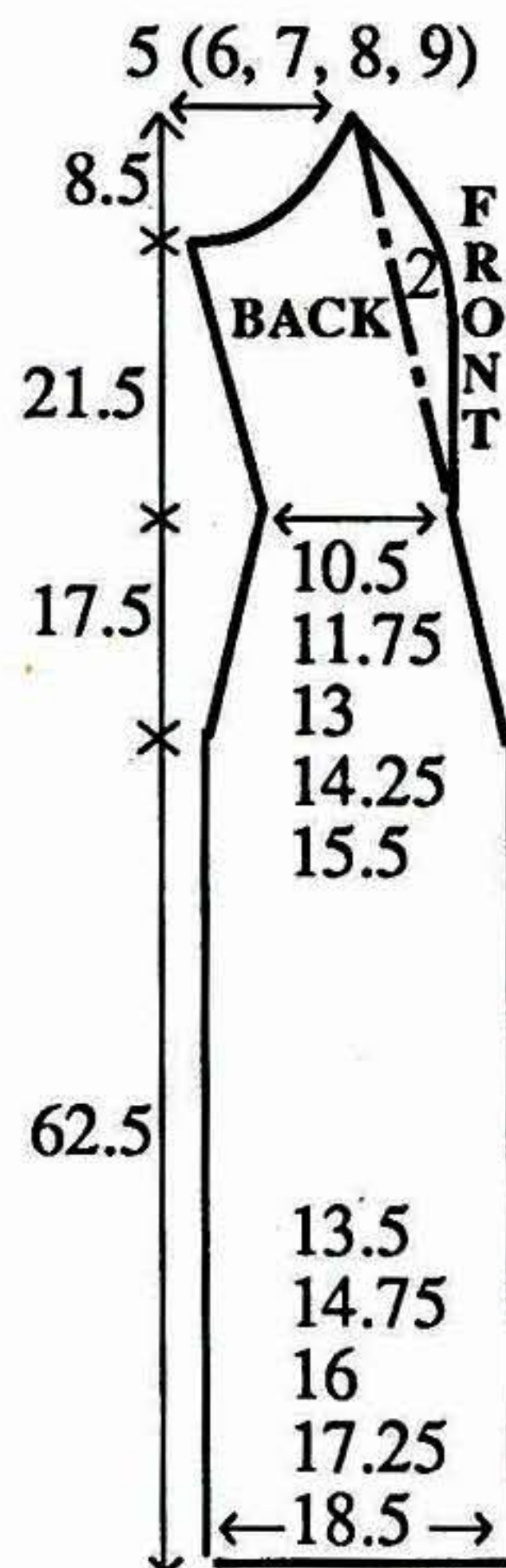

ARMBANDS

Join shoulders and NECK-TRIM seams. As NECKTRIM using 125 (129, 133, 137, 141) KH Ns.

MAKE-UP

Block and press. Join side seams. Press seams.

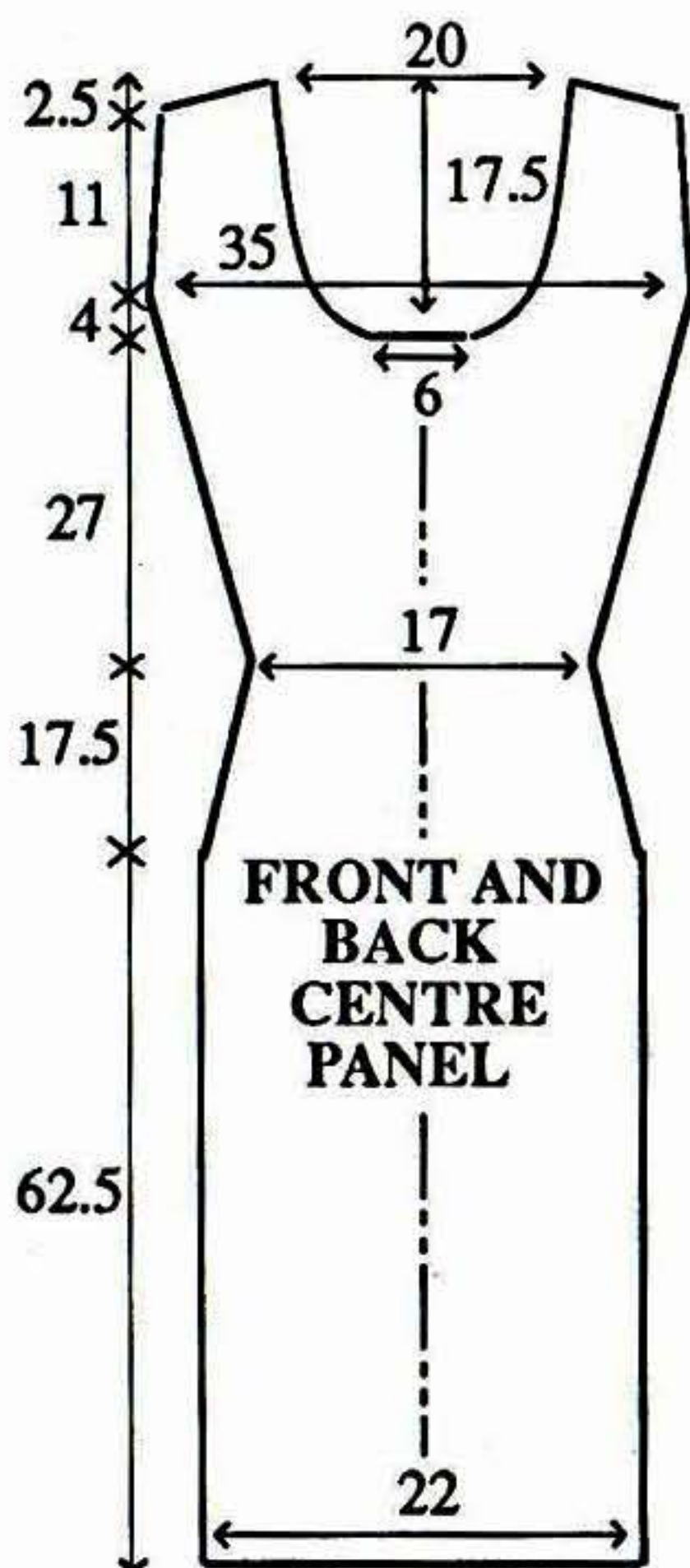

NECKTRIM (2)

Push 129 KH Ns into WP. With right side facing, pick up same number of sts evenly along FRONT/BACK neck edge and place onto Ns. T4 knit 1 row. T1 knit 6 rows. T10 knit 1 row. T1 knit 7 rows. T4 knit 1 row and waste knit. Fold in half to



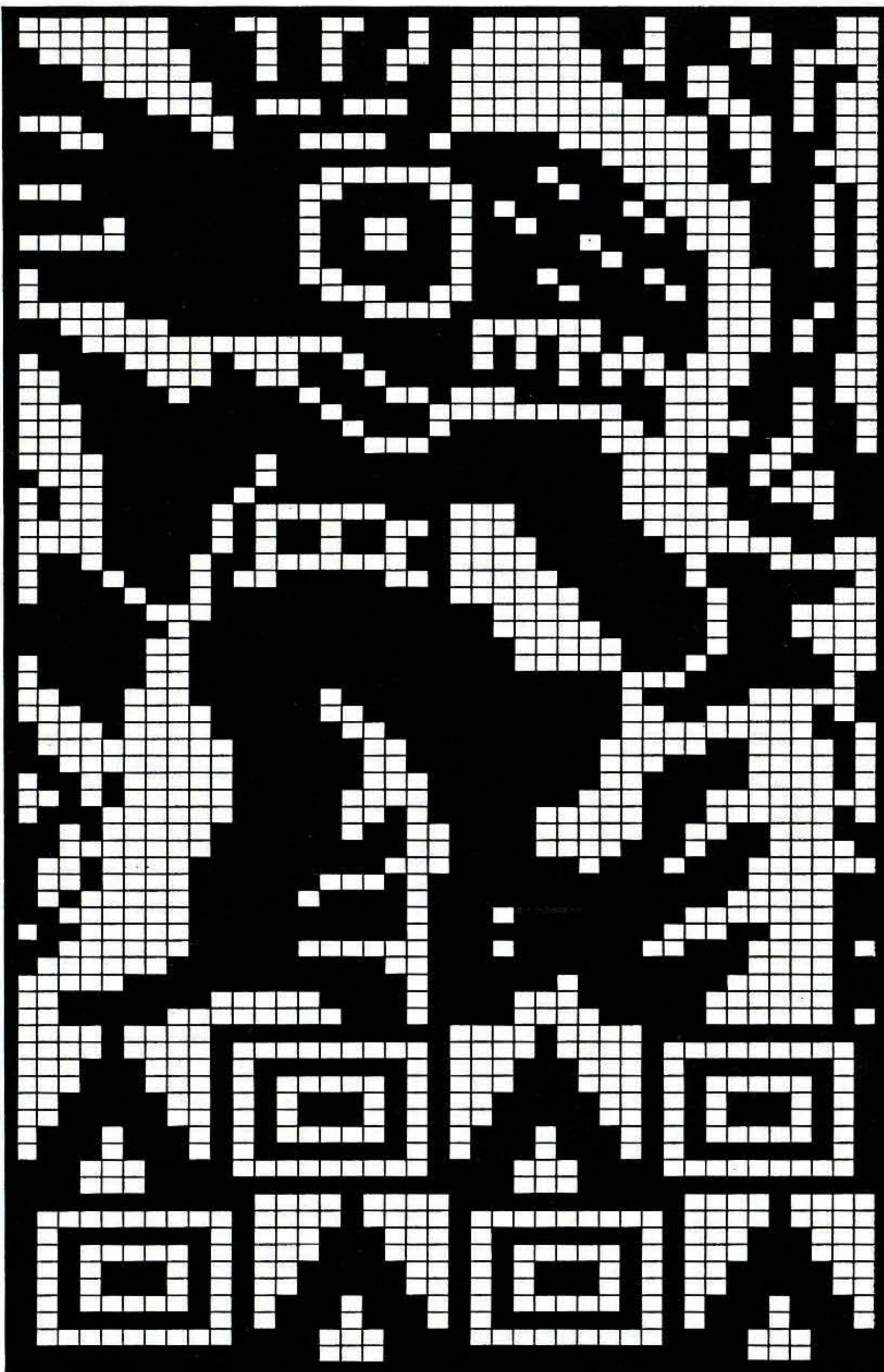

Stitch Library

Choose a stitch design from our Library, based on designs from ancient Ecuador for a waistcoat or lined coat - colour it any way you like!

EARTH COLOURS - PAGE 23

MASKED MAN - TOP LEFT
With Brown in FA throughout, rotate the following yarns in FB:- 10 rows Copper, 10 rows Amber, 26 rows Rose, 14 rows Copper and 20 rows Amber.

DOG - TOP RIGHT
With Mink in FA throughout, rotate the following yarns in

FB:- 8 rows Copper, 16 rows Amber and 16 rows Primrose.

BAT - BOTTOM LEFT
With Brown in FA throughout, rotate the following yarns in FB:- 10 rows Pink, 12 rows Sand, 22 rows Amber and 12 rows Sand.

MEN CONVERSING - BOTTOM RIGHT
With Wine in FA throughout, rotate the following yarns in FB:- 16 rows Cerise, 24 rows Copper and 18 rows Amber.

SEA COLOURS - PAGE 25

FISH - TOP LEFT
With Forest Green in FA throughout, rotate the following yarns in FB:- 6 rows Turquoise, 12 rows Sand, 14 rows Pale Green.

FISH - TOP RIGHT
With Ocean Blue in FA throughout, rotate the following yarns in FB:- 10 rows Olive, 12 rows Lilac and 14 rows Pale Blue.

FISH - BOTTOM LEFT
With Navy in FA throughout, rotate the following yarns in FB:- 6 rows Pale Blue, 12 rows Olive and 24 rows Lilac.

FISH - BOTTOM RIGHT
With Green in FA throughout, rotate the following yarns in FB:- 2 rows Turquoise, 2 rows Olive, 2 rows Turquoise, 2 rows Olive, 2 rows Turquoise, 12 rows Olive, 16 rows Pale Blue.



