

Your guide to INSTANT PUNCHCARD FASHION

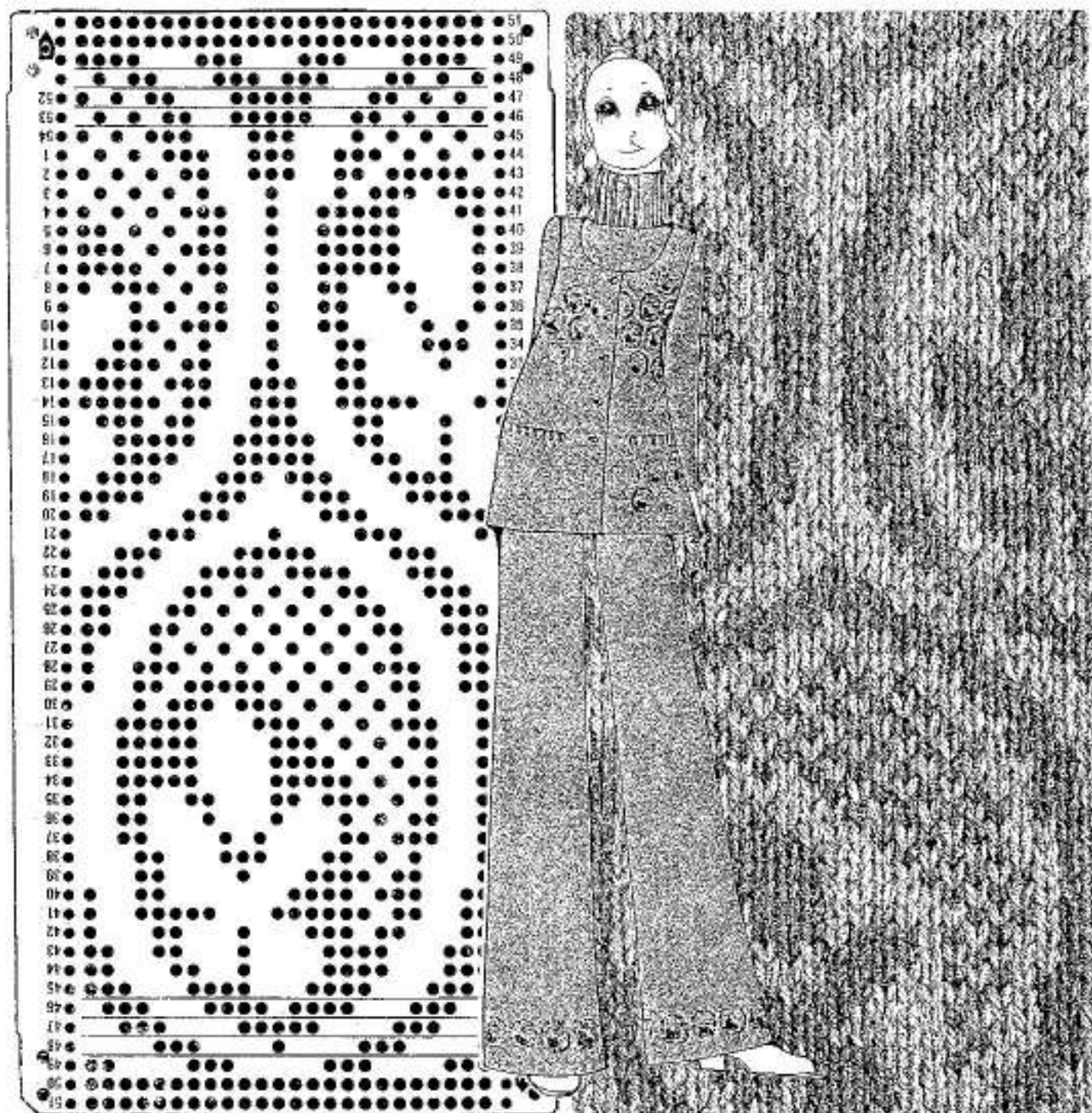

Empisal-Knitmaster
model 321/323 AUTOMATIC



NOTE

MERKE

NOTEZ

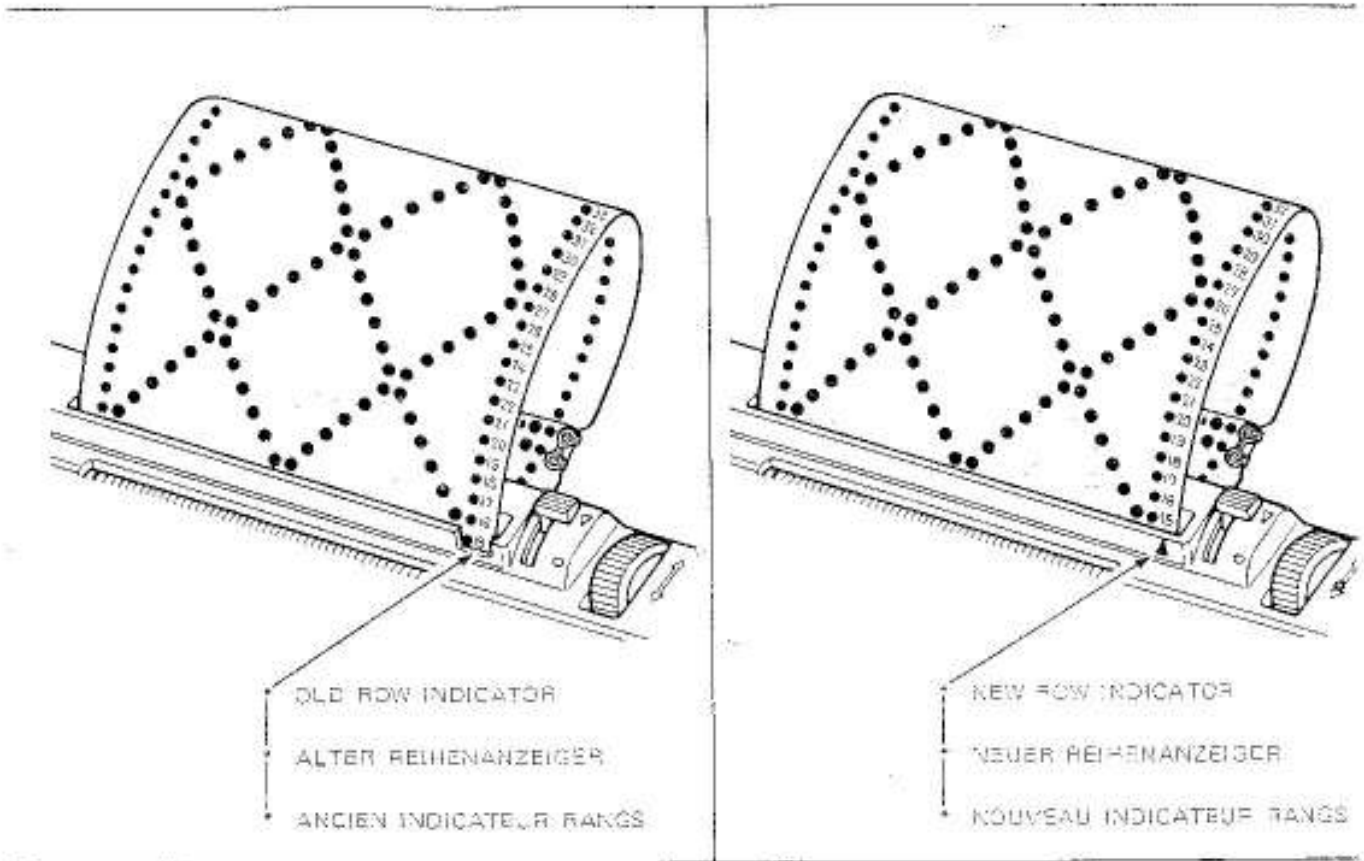

* No matter which of these Row Indicators your machine has, the instructions remain the same.

* Für beide Reihenanzeiger gilt die gleiche Anleitung.

* Les instructions pour les différents Indicateur rangs restent les mêmes.

KNITTING

This booklet has been divided into 4 basic and easy-to-follow STEPS, with all you need to know about machine knitting - BUT KNITTING WITH 200 NEEDLES INSTEAD OF JUST 2.

STEP **1**



Identification of accessories	2 - 3
Interesting notes about yarn	4 - 6
Setting up the machine and knitting	8 - 23
Closed edge cast-on and casting off	25 - 27
Blocking, Cord Knitting, Fringing	28 - 29
Tension Guide	30 - 31
Sewing	32 - 34

ACCESSORIES



Accessory Case



Card guide pin



Straight and 1/1 Needle Pusher



3/1 and 1/3 Needle Pusher

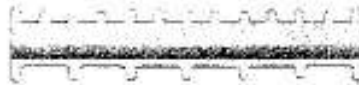

1/2 and 1/5 Needle Pusher

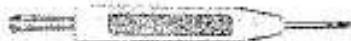

Single and Double Transfer Tool



Single and Triple Transfer Tool

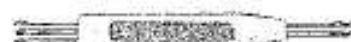

Double and Triple Transfer Tool



Latchet Tool



3 spare needles and seaming needle



Crochet and work hook



Nylon Cord



Carriage Lock Plate



Brush

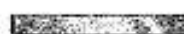

Needle Retaining bar Pusher



Card clamps

ACCESSORIES

Sinker Arm Assembly

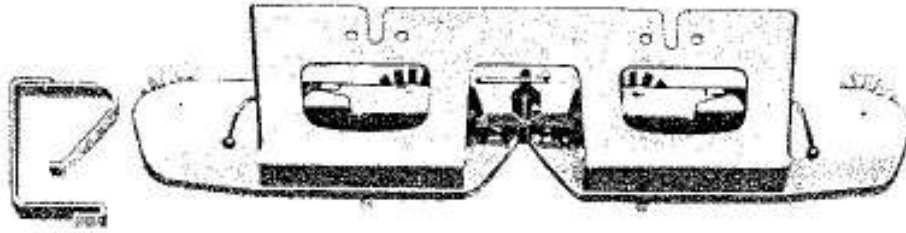

Rib Frame



Weaving Brush



Row Counter



Claws

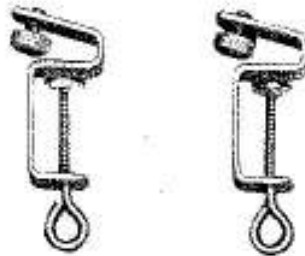

Table Clamps



Oil Bottle



Yarn Guide

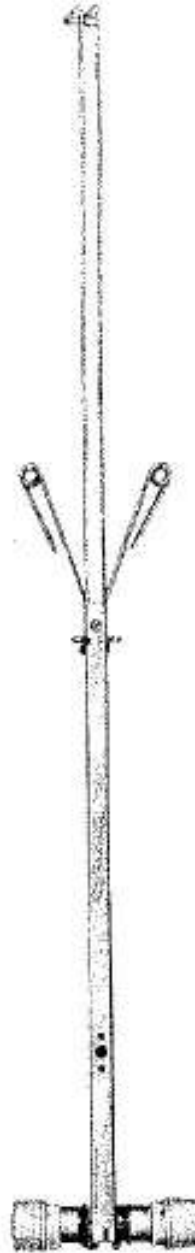

Yarn Brake



Yarn Brake Rod

PREPARATION OF YARNS

Your new knitting machine has been designed to give you perfect results using a wide range of yarn, from cotton thread and light weight yarn, to knitting worsted and even thicker. However, it is best to **START WITH A STANDARD BABY WEIGHT YARN**. Always use the best quality yarn available, and remember . . . your garment can never be better than the yarn you choose.

Correct preparation of yarns before you start knitting is important. This extra care will make knitting much more enjoyable, easier, and the quality of your garment much better.



It is quite impossible to knit from a hank like this. You will have to open it and place it on your arms (or on a skein holder if you have one) to wind it into a ball, suitable for machine knitting.



This hand wound ball of yarn looks good, but it is completely unsuitable for machine knitting. It will roll around and become tangled. You **MUST** rewind it, using the yarn winder.

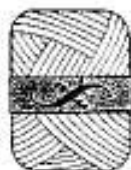

It is not suggested that you **USE** a pull skein of yarn with the knitting machine, as it is impossible to knit with the outside end of the yarn. Pulling the end of yarn from the center is not recommended, since the yarn end does not always draw smoothly and there may be knots.

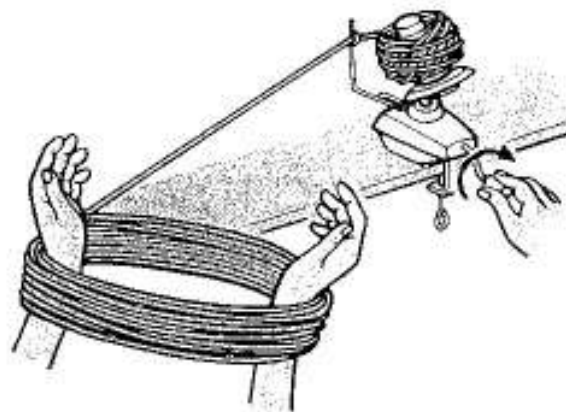
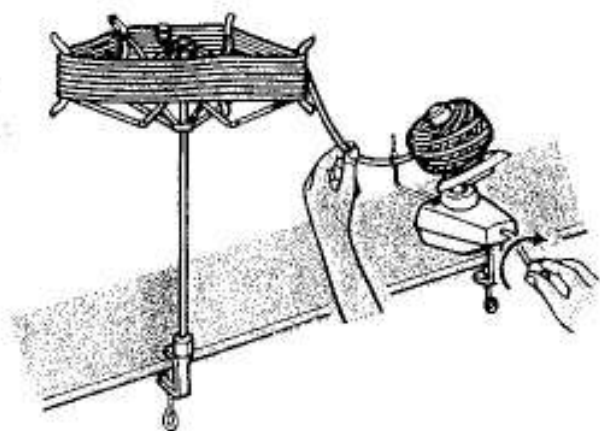

USEFUL OPTIONAL EXTRA ACCESSORY

Place the hank on skein holder and wind into a ball using the yarn winder.

OR -- you may ask somebody to hold the hank for you while you wind it into a ball using the yarn winder.

I am sure you have a few 'left-over' balls of yarn lying around at home. **PLEASE DO NOT** use this yarn while learning. Use a fine lightweight yarn. As you become accustomed to machine knitting, you can use all types of yarn. Meanwhile, **ONLY** use the recommended yarn, and wind it exactly as explained in the instructions on the following page.

THE AUTOMATIC YARN WINDER

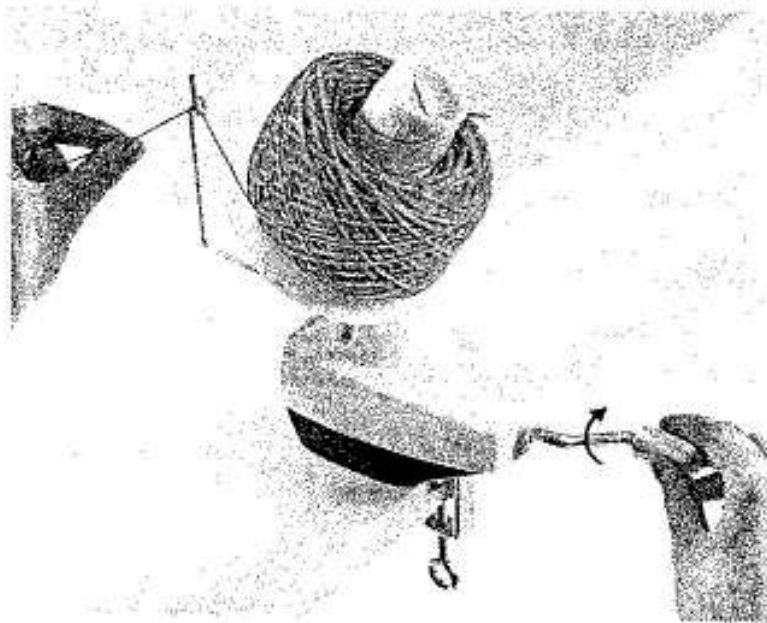

The yarn winder will wind your yarn speedily and perfectly, ready for machine knitting. It saves a great deal of time by winding the yarn into a ball in only a few seconds.

USEFUL OPTIONAL EXTRA ACCESSORY

When winding the yarn the first time . . . hold a wax candle or wax in your hand, and merely allow the yarn to run over the wax while winding. This will smooth the tiny hairs on the yarn and make it ready for smooth, easier knitting . . . also very helpful for automatic patterning. All traces of wax will disappear when steaming and blocking the garment.

When you wax the yarn at the same time as you wind, the ball will be small and tight. You CANNOT knit from this small, tight ball. You MUST REWIND IT, allowing the yarn to run loosely through your hand.

Your machine will knit the yarn so quickly and effortlessly, you won't have time to catch knots and snags. If a knot passes through your hand as you wind – STOP. Unknot it if possible, then continue winding. If two ends are tied together into a knot, untie it (or cut it) and start a new ball, NEVER leave knots inside your yarn ball as they may cause errors or dropped stitches as you knit. It is important to the smooth running of your machine to have well wound yarn with all knots and snags removed.

The yarn winder is also very useful while you are still practising your first swatches, as you are able to unravel and rewind the knitted yarn. Always start unravelling from the last row knitted. When joining yarns, make sure the yarn ends come at the BEGINNING or END of a row. When you see that the ball is almost finished, pull the yarn down from the Yarn Brake and re-thread with a new ball of yarn.

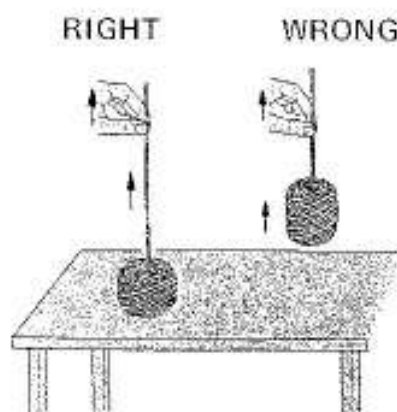

AN IMPORTANT TEST

WHEN THE YARN IS PULLED FROM THE CENTER OF THE BALL – THE THREAD MUST COME OUT FREELY WITHOUT LIFTING THE BALL FROM THE TABLE.



THE WONDERFUL, YET SO SIMPLE LATCH NEEDLE

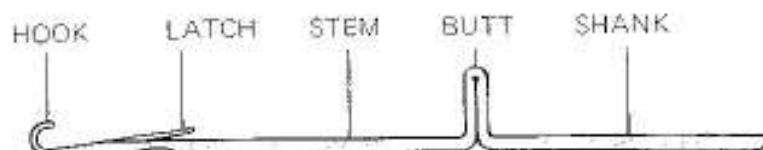

Over a century ago, the latch needle was invented in Europe. This invention was so wonderful that, to this day, the basic shape of latch needles has remained unchanged and machines fitted with these needles are used to produce most of the knitwear on sale today.

HOW STITCHES ARE FORMED

The movement of the latch needle, in and out of the needle bed while knitting, is controlled by the carriage.

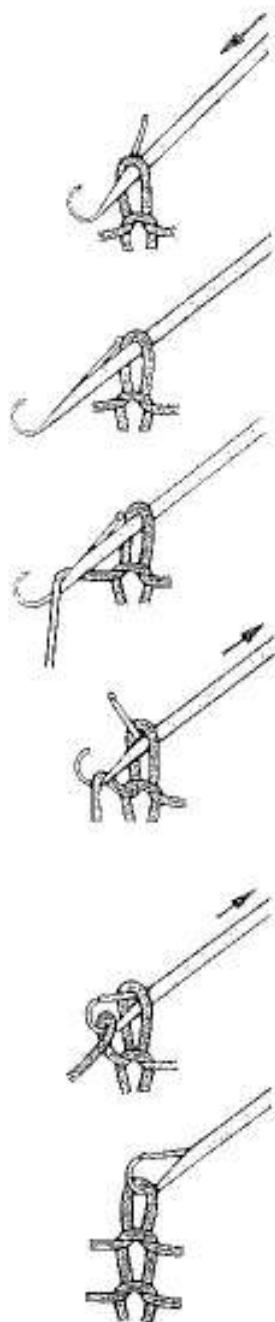

1. As the needle moves out, the stitch automatically opens the latch.
2. The needle moves out further and the stitch slides behind the latch.
3. The yarn is automatically fed on to the hook by the Yarn Feeder — preparing for a new stitch.
4. The needle moves back inside the needle bed and the previous stitch slides forward causing the latch to close over the yarn inside the hook.

The latch needle will ONLY drop a stitch if there is NO YARN in the needle hook when the needle returns into the needle bed.
5. The needle is pulled backwards, causing the previous stitch to slide on to the needle latch.
6. When the needle is completely pulled back - the previous stitch slides over the closed latch and the yarn forms a new stitch in the needle hook.

As this cycle of movements is repeated, stitches are formed and when the carriage moves across the needle bed 200 needles form as many stitches in the manner explained above.

THE MAIN PARTS OF THE MACHINE

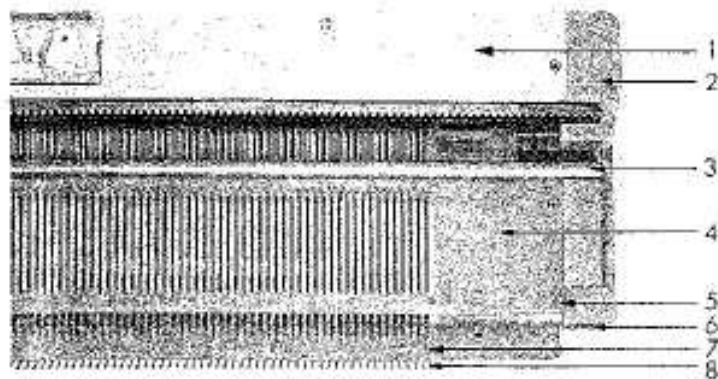

NEEDLE BED

1. Rear Cover Plate
2. Side Covers
3. Carriage Guide Rail
4. Needle Bed
5. Needle Retaining Bar
6. Yarn Clip (left & right)
7. Needle Number Plate
8. Sinker Gate and Sinker Gate pins

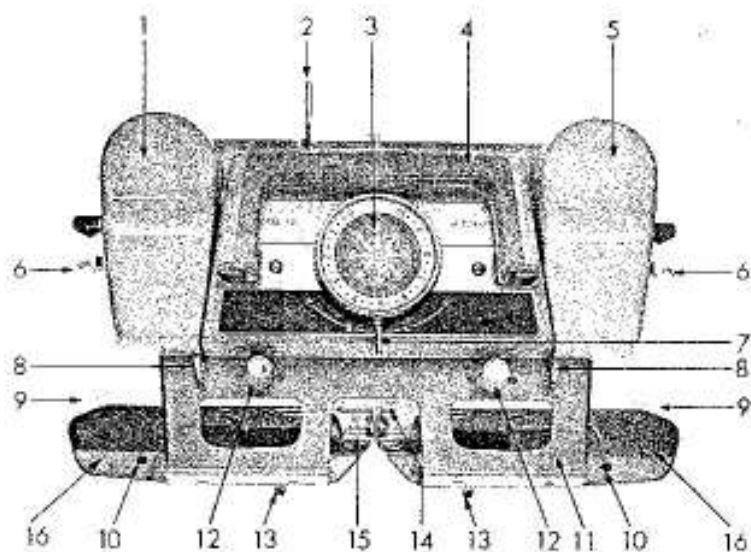

CARRIAGE PARTS

1. LEFT side Pattern Memory
2. Row Counter Tripper
3. Tension Dial
4. Carriage Handle
5. RIGHT side Pattern Memory
6. Side Levers (left & right)
7. Cam Lever
8. Front levers (left & right)
9. Brush Wheels (left & right)
10. Weaving Guides (left & right)
11. Sinker Arm Assembly
12. Thumb Screws to fasten Sinker Arm Assembly on to the carriage.
13. Arm Levers (left & right)
14. Lock Spring of Yarn Feeder
15. Yarn Feeder
16. Sinker Arm Plate

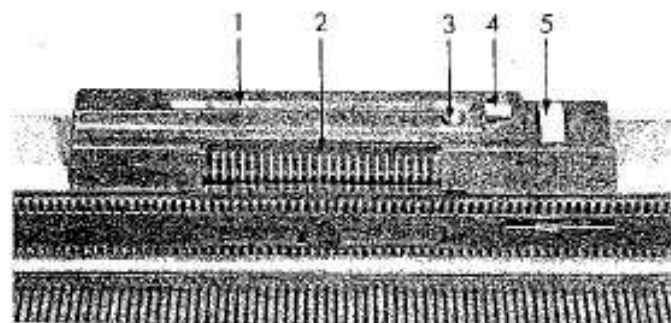

PATTERN PANEL

1. Card Slit
2. Touch Levers
3. Row Indicator
4. Card release
5. Feeding Dial

UNPACKING THE MACHINE

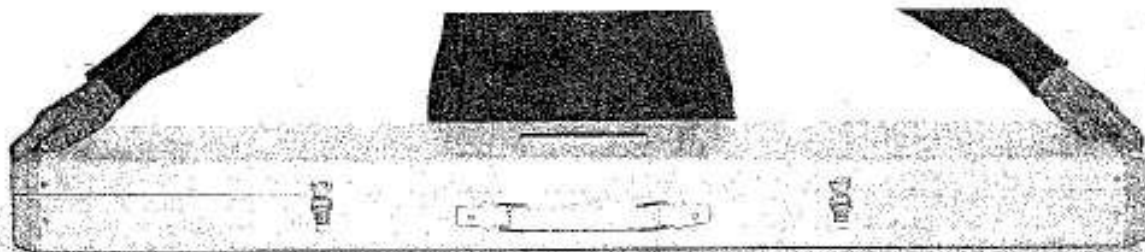

1. Place the knitting machine with handle of carrying case away from you.

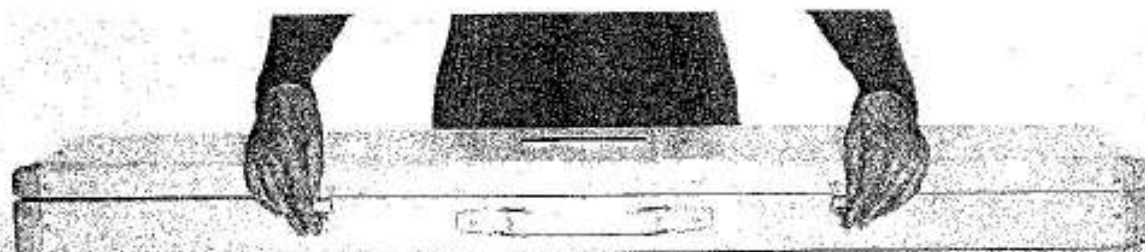

2. Unlock the latches on both sides of the handle.



3. Lift the upper case slightly and pull cover towards you to free it.



4. Place the cover to rear of machine, the lower side of the cover forward.

UNPACKING THE MACHINE

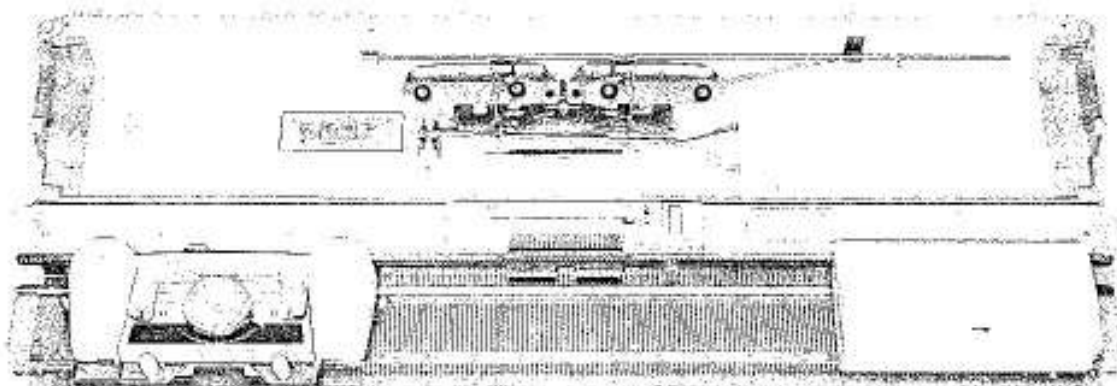

On RIGHT side of the needle bed is a Case for the small Accessories.

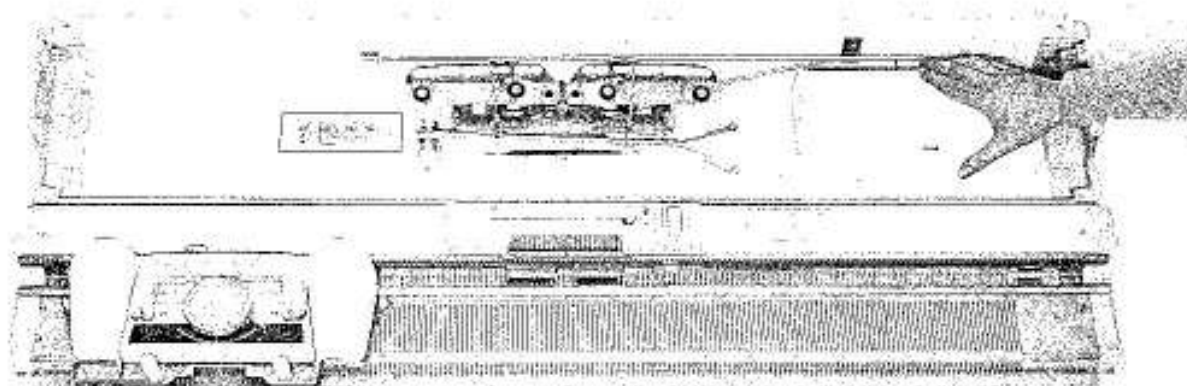

Raise the accessory case to remove it from the needle bed. Place it inside the cover.

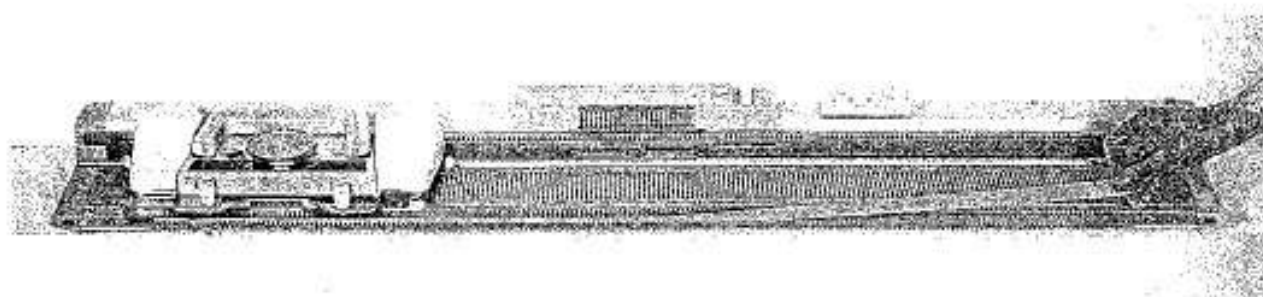

Remove the cardboard Needle Protector from the Sinker Gate of the machine.

SETTING UP THE MACHINE

Take the two Table Clamps from inside the Accessory Case.

Turn screws A and B until they are wide open.

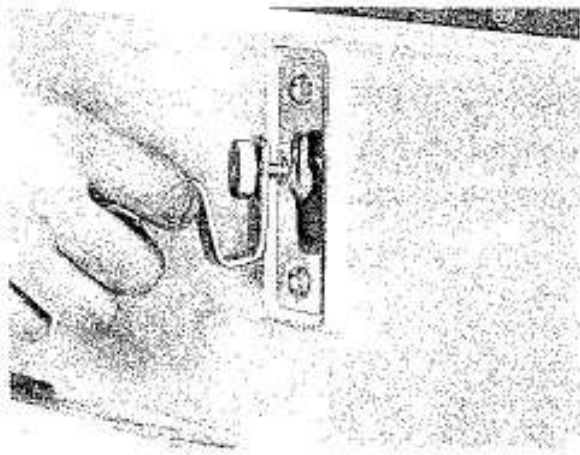
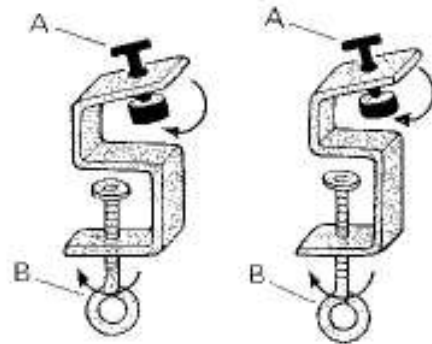

1. Raise the front of the machine; insert the heads of the screws into the keyhole slots.

Pull the heads of the screws upwards and fasten tightly.

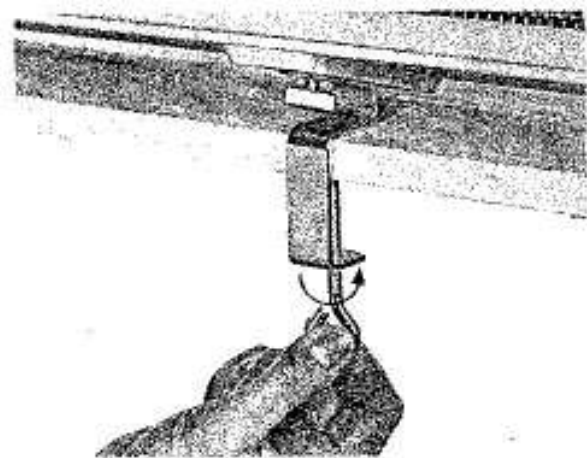

2. Fasten the machine to the table by tightening the Table Clamp screws as shown by the arrow.

The position of the machine will be slightly tilted to the rear when properly clamped on the table.

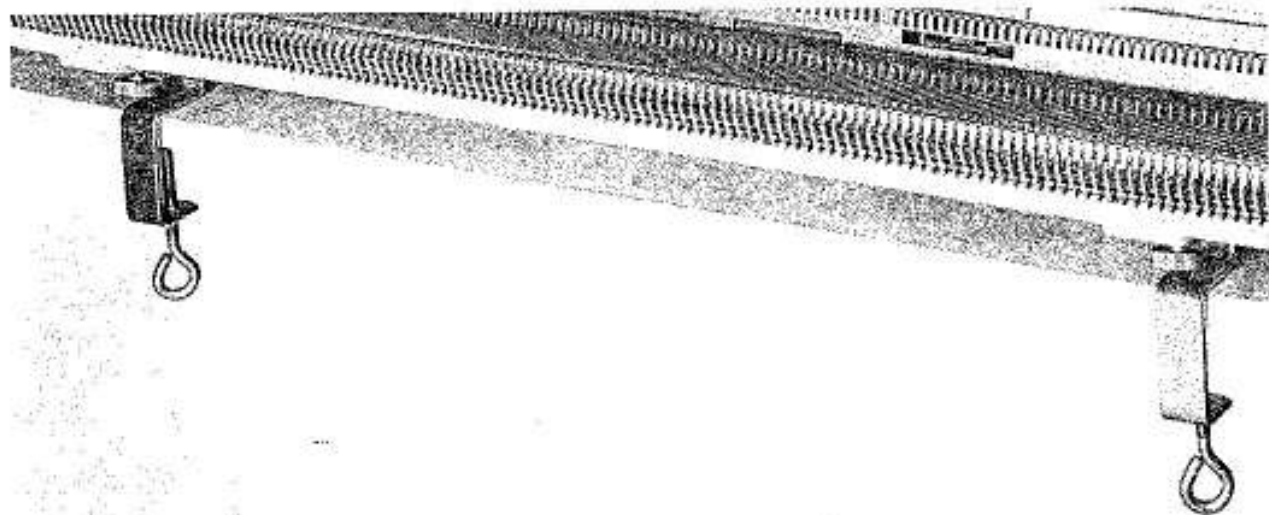

SETTING UP THE MACHINE

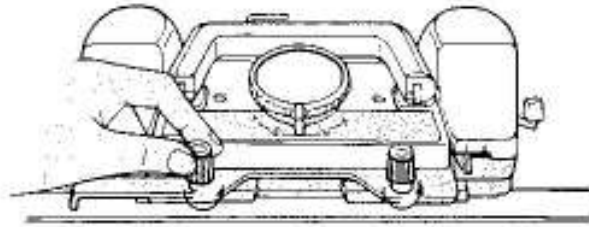

TO PROTECT THE MACHINE WHILE IN TRANSIT OR WHILE IT IS NOT BEING USED, THE CARRIAGE IS SECURED AT THE LEFT HAND SIDE OF THE NEEDLE BED BY MEANS OF A LOCK PLATE.

To free carriage - turn both white thumb screws until they are loose.

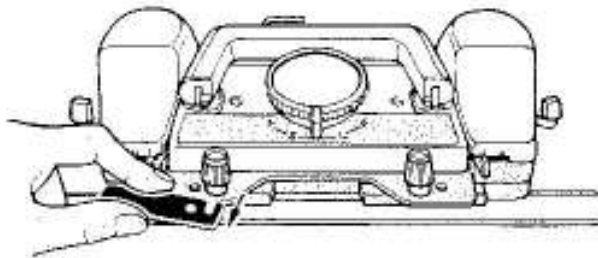

Set LEFT side Front Lever to II.
Remove the Lock Plate by pulling it towards you, away from the carriage and off the needle bed. Keep it in the Accessory Case.
Set LEFT side Front Lever to I.

NOTE: Whenever the machine is not in use, be sure to replace the Lock Plate to fasten the carriage to the needle bed.

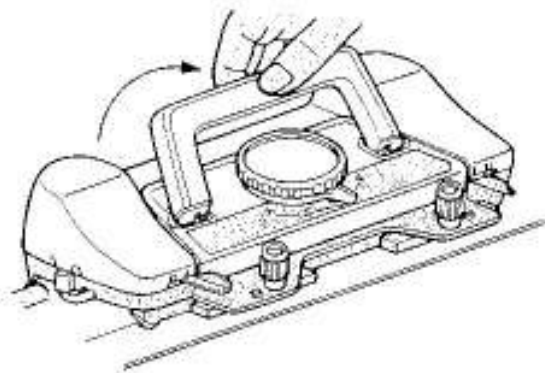

Raise the handle until it snaps into a locked vertical position.

When machine is not in use, snap handle back down flat.

THE AUTOMATIC ROW COUNTER

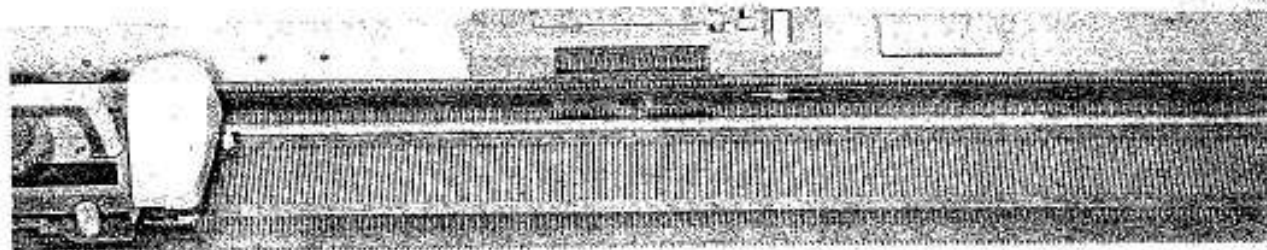

On the LEFT and RIGHT sides of the Pattern Panel are two sets of studs. You may place the Row Counter on either of these sets, But the Row Counter is placed on the RIGHT hand set of studs when you unpack the machine. Leave it there.

The Row Counter is automatically operated by the Row Counter Tripper at the center rear of the carriage. Each time the carriage moves past the Row Counter it will register one more row of knitting.

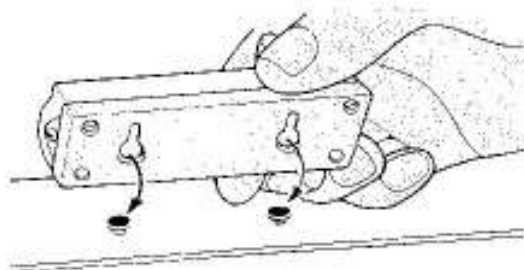

Later if you need the Row Counter on the LEFT side of the machine, push it towards you and lift it off the studs.

At the LEFT, place it with the two keyholes on the underside, on top of the two studs. Push it down and back, this will lock the Row Counter in position.

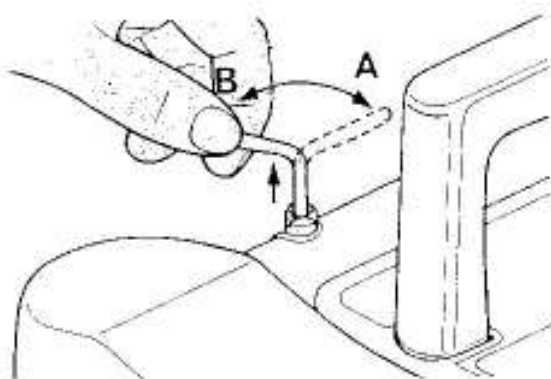

To put the Row Counter Tripper into operation, pull it upwards and point it towards the back.

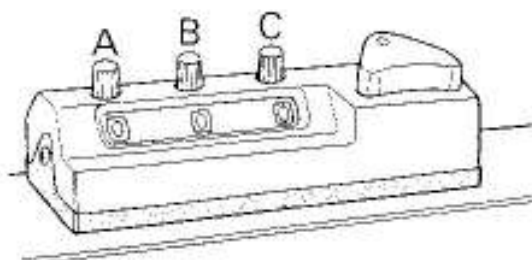

You can reset your Row Counter to zero by turning the thumb screws A, B, C.

ATTACH THE SINKER ARM ASSEMBLY

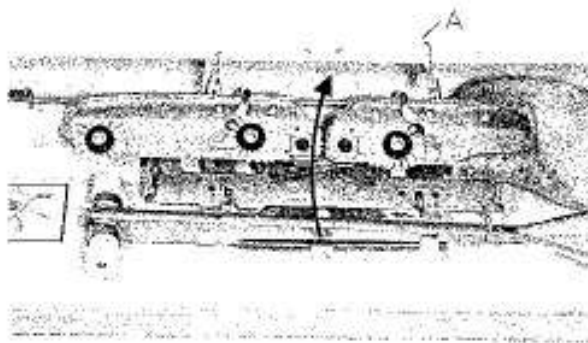

Remove the Sinker Arm Assembly from the cover.

Release the Retaining Spring A by pushing it down on either side of the clip, then pull it forward and upwards.

To release the Sinker Arm Assembly move it a little backwards and then lift it up.

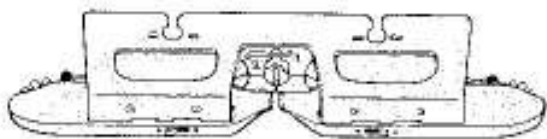

Turn the Sinker Arm Assembly so that the Brush Wheels are underneath.

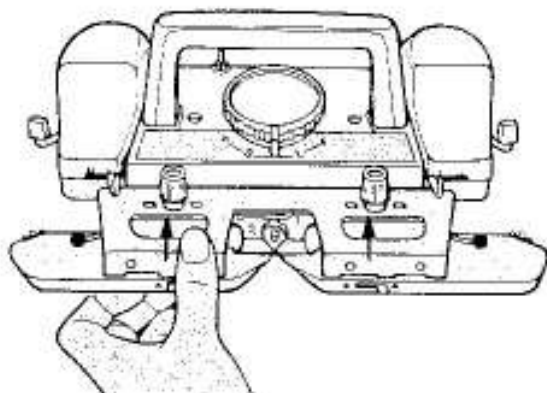

Slide the Sinker Arm Assembly UNDER the two thumb screws and push it back as far as it will go.

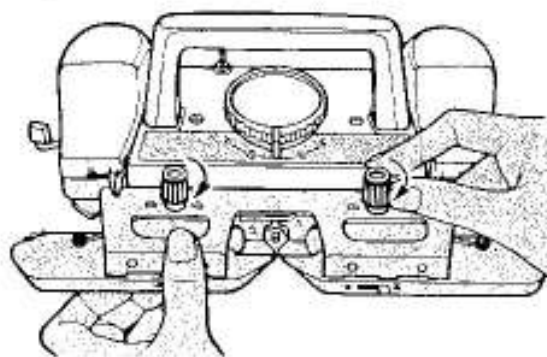

Tighten the thumb screws by turning them in a clockwise direction so that the Sinker Arm is firmly attached to the front of the carriage.

ALWAYS SECURE THE SINKER ARM FIRMLY ON TO THE CARRIAGE PLATE.

THE DIFFERENT NEEDLE POSITIONS

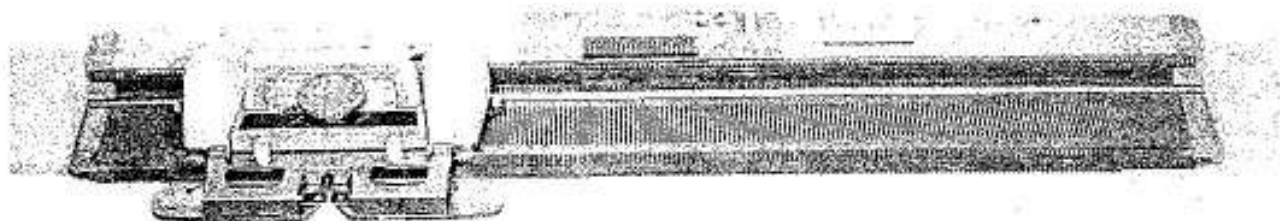

Your machine has 200 needles; they are numbered from the center 0 to the LEFT and RIGHT in groups of 10, 100 needles on each side of the center.

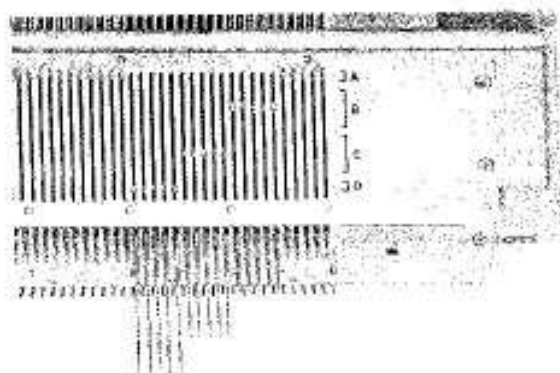

On both the LEFT and RIGHT side of the needle bed you will see markings A, B, C and D. These are the various needle positions used during knitting.

- A- non-knitting position.
- B- plain knitting and Stitch Patterns.
- C- for end needle when Front Lever to I.
- D- holding position for partial knitting - Front Levers MUST be set to I.

The movement of the needles between B - C and D position for special pattern effects is controlled fully automatically by the pattern memory of the carriage, so no need to worry about this, the general purpose is as above.

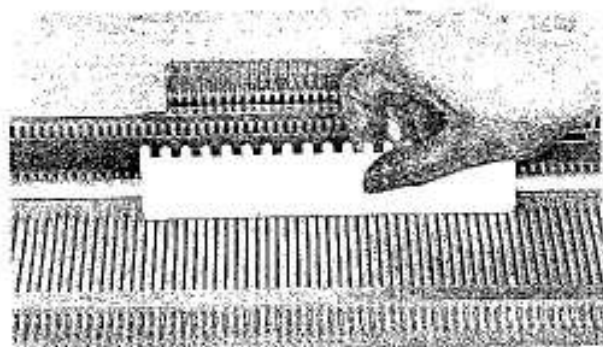

Move the carriage to the extreme LEFT of the machine, completely clear of ALL needles. Make sure that all needles are in A position. If some are not, take the straight edge Needle Pusher from the Accessory Case and push them back.

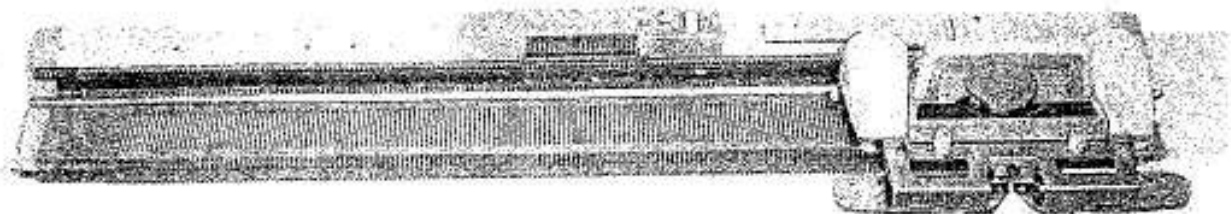

Slide the carriage across the needle bed to the RIGHT to ensure it moves smoothly and easily.

SETTING UP THE MACHINE

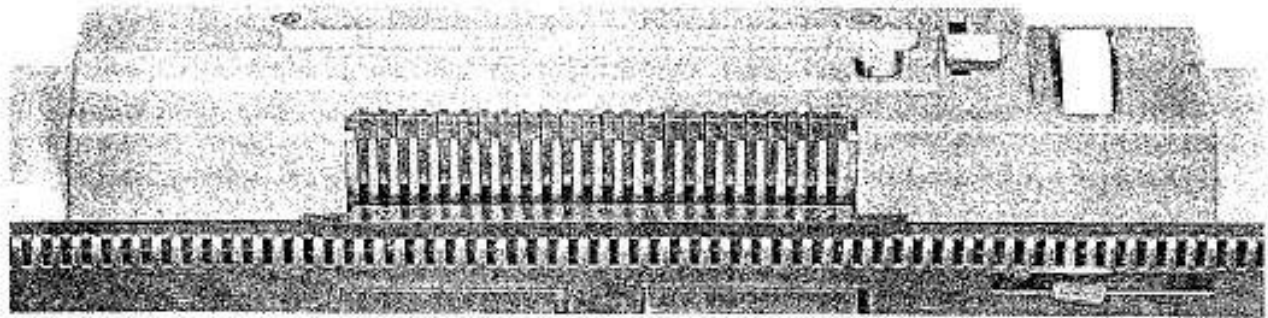

The position of the Pattern Panel is neutral. The card release is set to ●.

THE CAM LEVER

This little lever will enable you to dial the kind of Stitch pattern you wish to knit.

- T – for Tuck Stitch patterns,
- S – for Slip Stitch patterns,
- O – for Weaving patterns,
- L – for AUTOMATIC Lace patterns,
- F – for AUTOMATIC Fair Isle patterns.

The Cam Lever is set to center O unless stated otherwise.

The positions on the carriage are:

1. Side Levers to FRONT.
2. Front Levers to I.
3. Cam Lever to center O.
4. Arm Lever to ▽

Move the carriage to the LEFT.

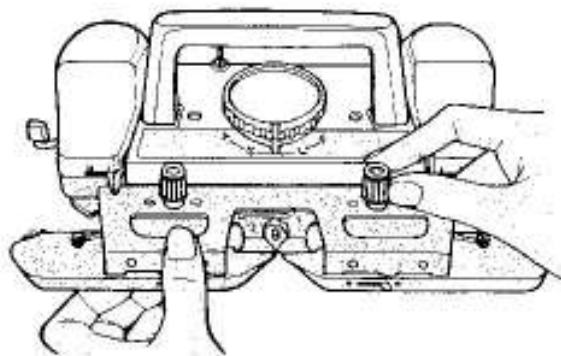
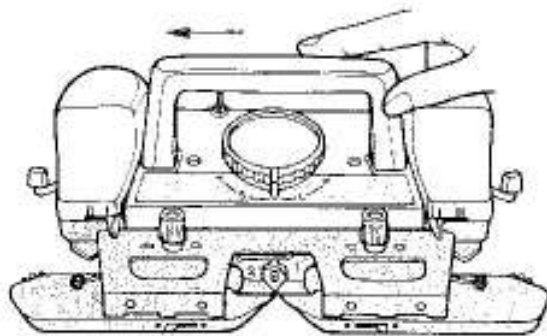

If the carriage does not move smoothly across the needle bed, check if the Sinker Arm Assembly is secured properly on to the carriage.

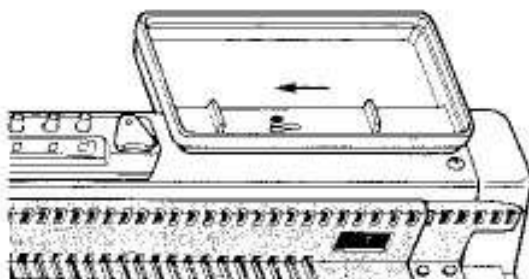

The top of the Accessory Case can be used as a tray for your accessories during knitting.

At the far RIGHT side of the rear cover is another stud, allow it to pass through the keyhole slot of the tray. To secure the tray, slide it to the LEFT.

SETTING UP THE MACHINE

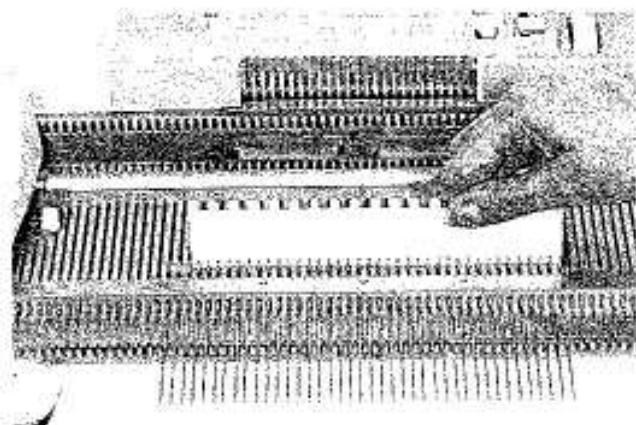

The carriage is at the LEFT. Using the straight edge Needle Pusher, bring 20 needles on EACH side of center from A to D position, this means 40 needles completely towards the front of the needle bed.

The more needles you push up to D position — the wider your knitting will be.

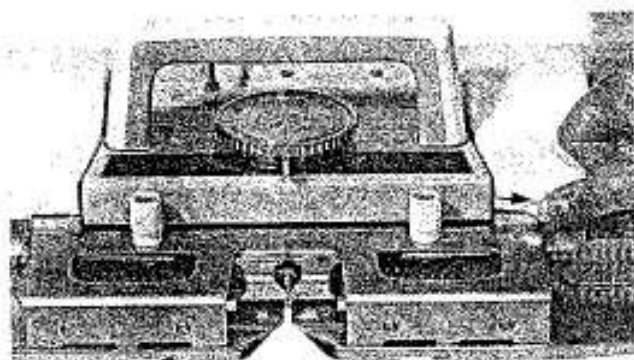

Set the RIGHT side Front Lever to II. This means flat against the carriage front.

This will move the needles from D position back to B position when moving the carriage over the needles towards the RIGHT.

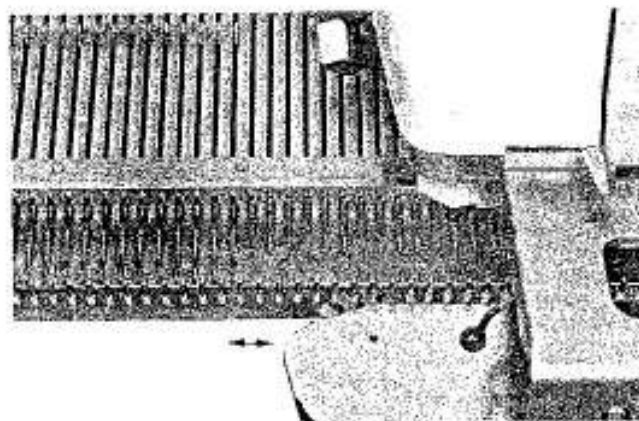

Move the carriage towards the RIGHT — PAST the needles in working position, let it rest when the LEFT side Sinker Arm plate has past the last needle in B position at the RIGHT. The needles moved back to B position because the RIGHT side Front Lever had been set to II. Set the RIGHT side Front Lever to I.

IMPORTANT POINTS TO REMEMBER:

1. NEVER stop the carriage in the middle of a row.
2. NEVER REVERSE the movement of the carriage IN THE MIDDLE of a row, or while it is still in contact with needles in B position.
3. ALWAYS move the carriage past ALL needles in working position and let it rest when the Sinker Arm plate has past the needles in working - 'knitting' - position.

Practice until you can slide the carriage smoothly back and forth across the needles. Be sure, each time that the Sinker Arm plate has past the needles in knitting position before reversing the direction. Leave the carriage at the RIGHT side of the machine.

SETTING UP THE YARN BRAKE

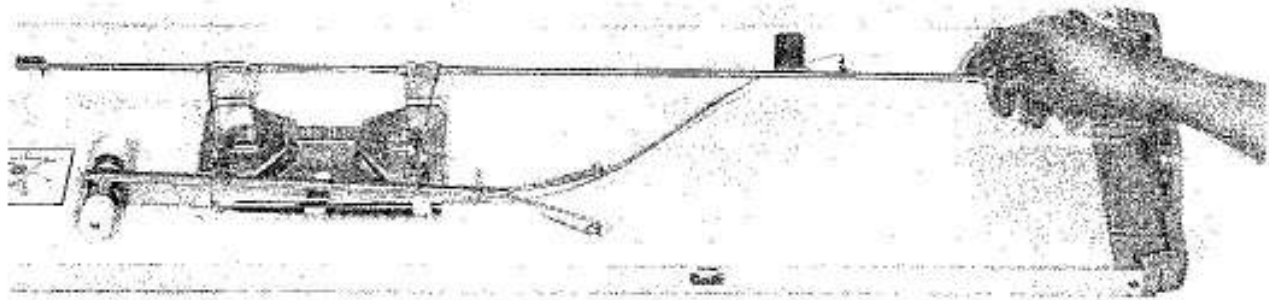

Lift the Yarn Brake Rod from the Retaining Clip inside the cover, and pull out of bracket at the LEFT .



At each side of Carrying Handle you can see a socket marked 'A'.

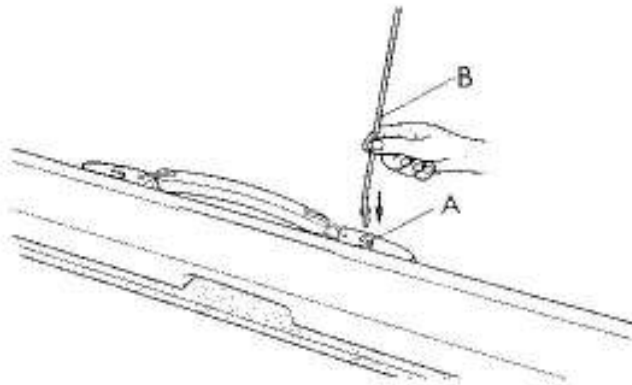

Insert bent short end of Yarn Brake Rod 'B' into socket 'A' at the right side of the Handle ensuring that Yarn Brake Rod slants in an angle to the back.

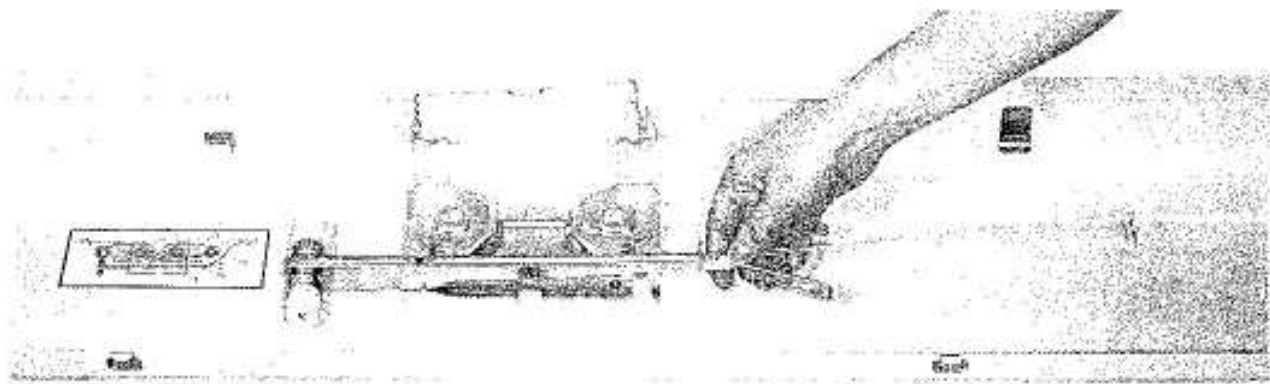

The Yarn Brake is retained by the same spring A through the Sinker Arm Assembly. Remove the Yarn Brake from the cover.

SETTING UP THE YARN BRAKE

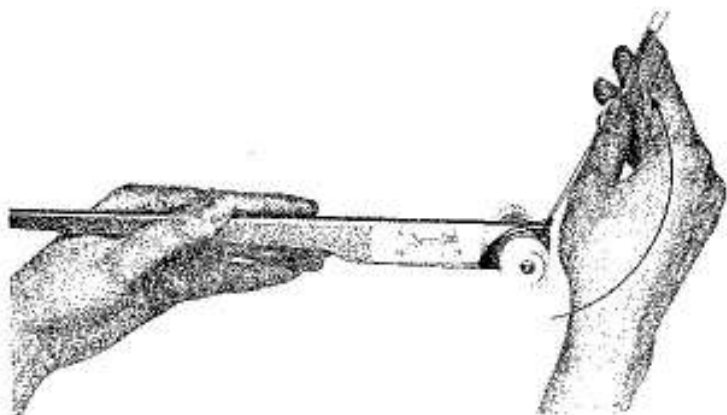

Turn the two Take-up Springs upwards as shown by the arrow until they snap into position.

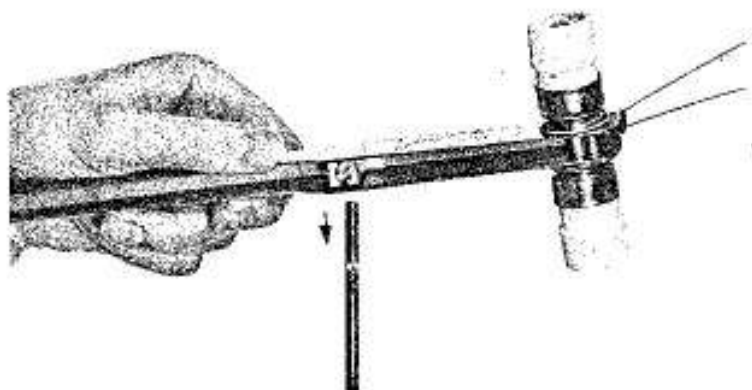

Place the Yarn Brake on to the Rod with the Take-up Springs at rear of the machine.

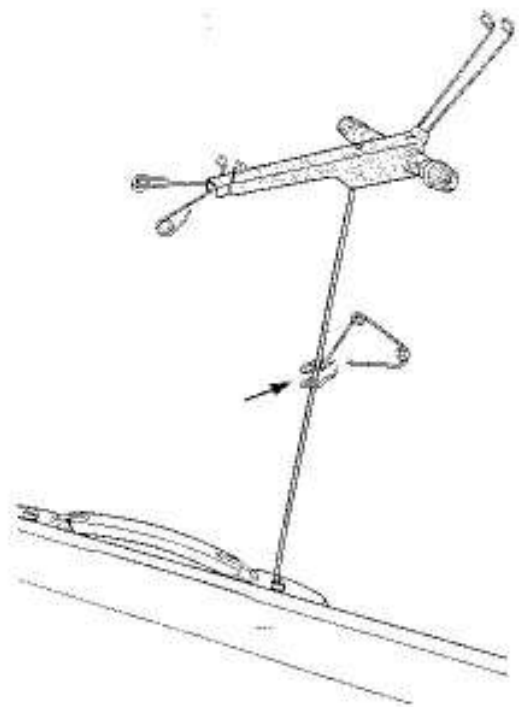

Take the Yarn Guide from the Accessory Case and clip it half way up the Yarn Brake Rod. The wire with the two guides must point towards the back.

THREADING THE MACHINE

YOU CANNOT KNIT IF YOU DO NOT THREAD EXACTLY AS SHOWN IN DIAGRAM.

1. Pull the yarn end out of the CENTER of the ball and thread it through (1) as shown.
2. Pull the yarn through the Yarn Brake (2).

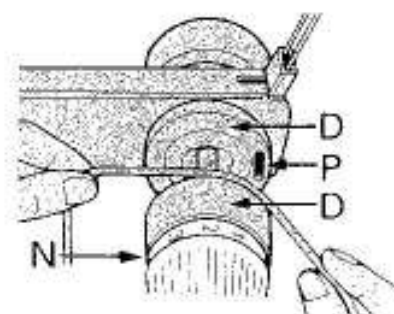
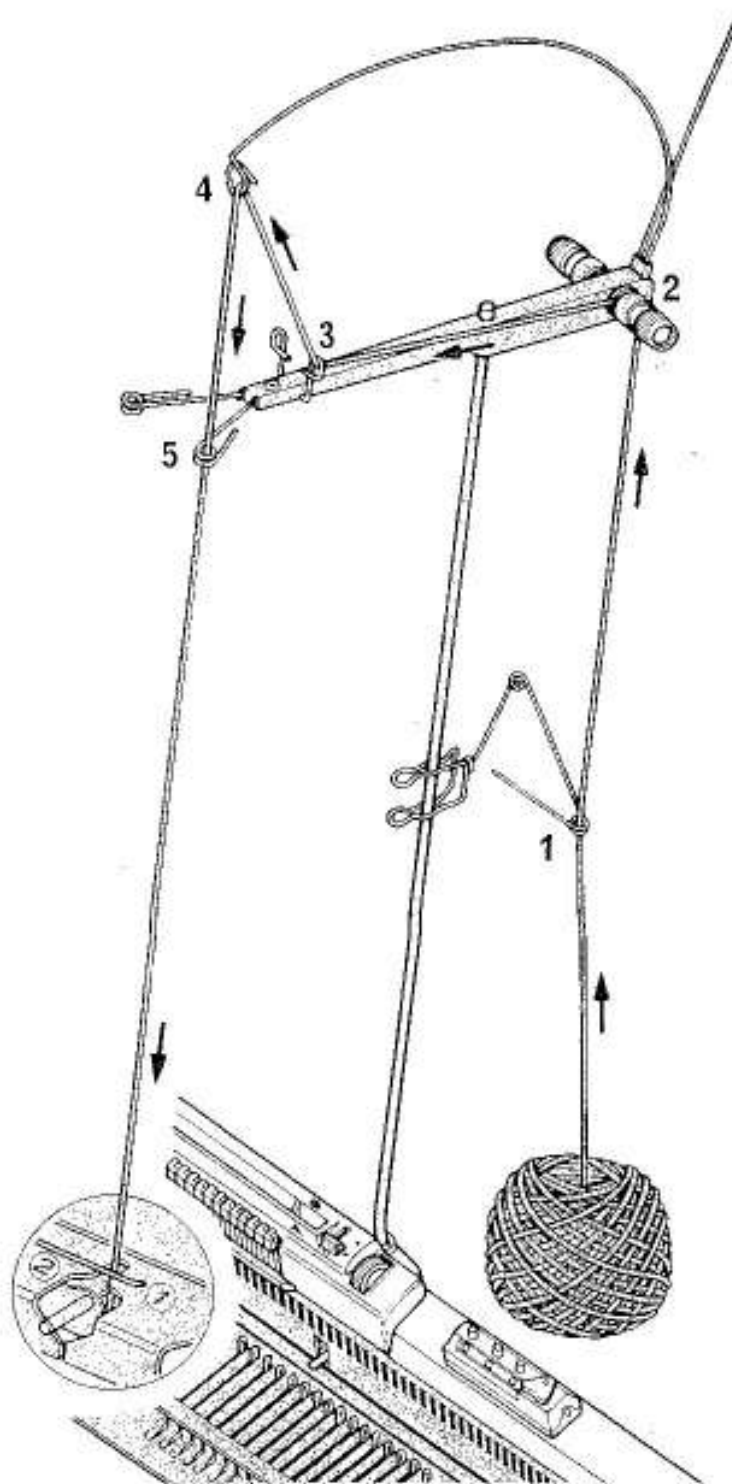

Place the yarn BETWEEN the two discs on the Yarn Brake pulling until you hear it click UNDER the pin.

THE LOCK PIN ENSURES THE YARN ALWAYS REMAINS BETWEEN THE DISCS DURING KNITTING.

Turn the plastic knob N until 3 is at the red arrow on the disc.

VERY IMPORTANT!

If the yarn is NOT placed BETWEEN the discs D and UNDER the pin P, you will have dropped stitches or lose loops at the edges of your knitting.

Thread the yarn through the Guide and Take-up Springs as shown at (3), (4) and (5). Pull the yarn DOWN from (5) and hold it down.

See Tension Guide Table on Page 30 for correct Yarn Brake setting for all yarn types.

THE YARN FEEDER

You are now ready to thread the yarn through the Yarn Feeder 1. Be sure to follow the steps exactly as illustrated.

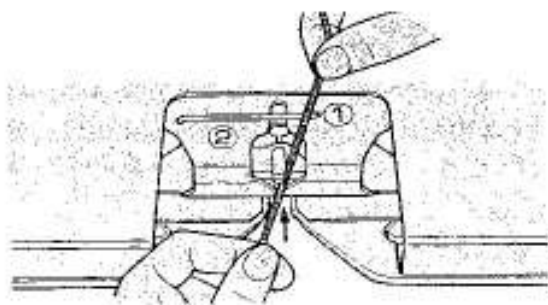

The yarn is ALWAYS threaded through Yarn Feeder 1, Feeder 2 is ONLY used when knitting Lace or Fair Isle patterns.

With BOTH hands hold the yarn as illustrated. Bring the thread THROUGH the front opening of the Yarn Feeder.

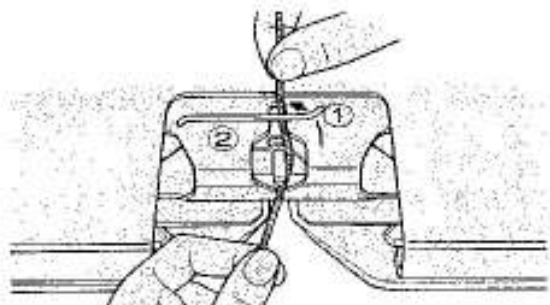

Pull the thread UNDER the Feeder lock spring as shown by the arrow.

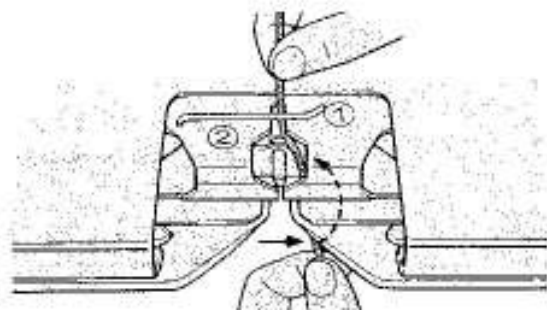

UNDERNEATH the Sinker Arm, pull the thread towards the RIGHT, the thread will slide BEHIND the separating plate inside the Yarn Feeder.

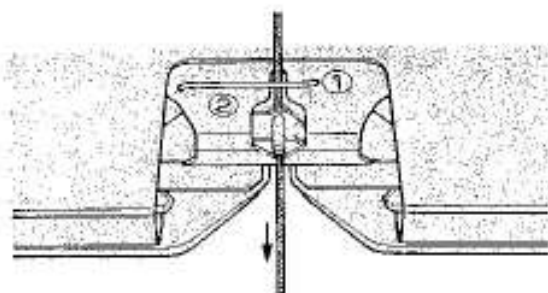

Here you can see the yarn correctly threaded in Yarn Feeder 1.

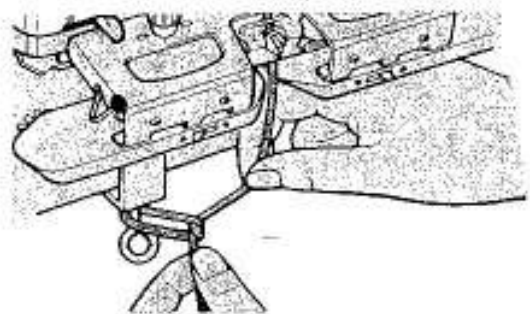

Pull more yarn down and fasten the end on to the RIGHT side Table Clamp.

THE YARN TENSION

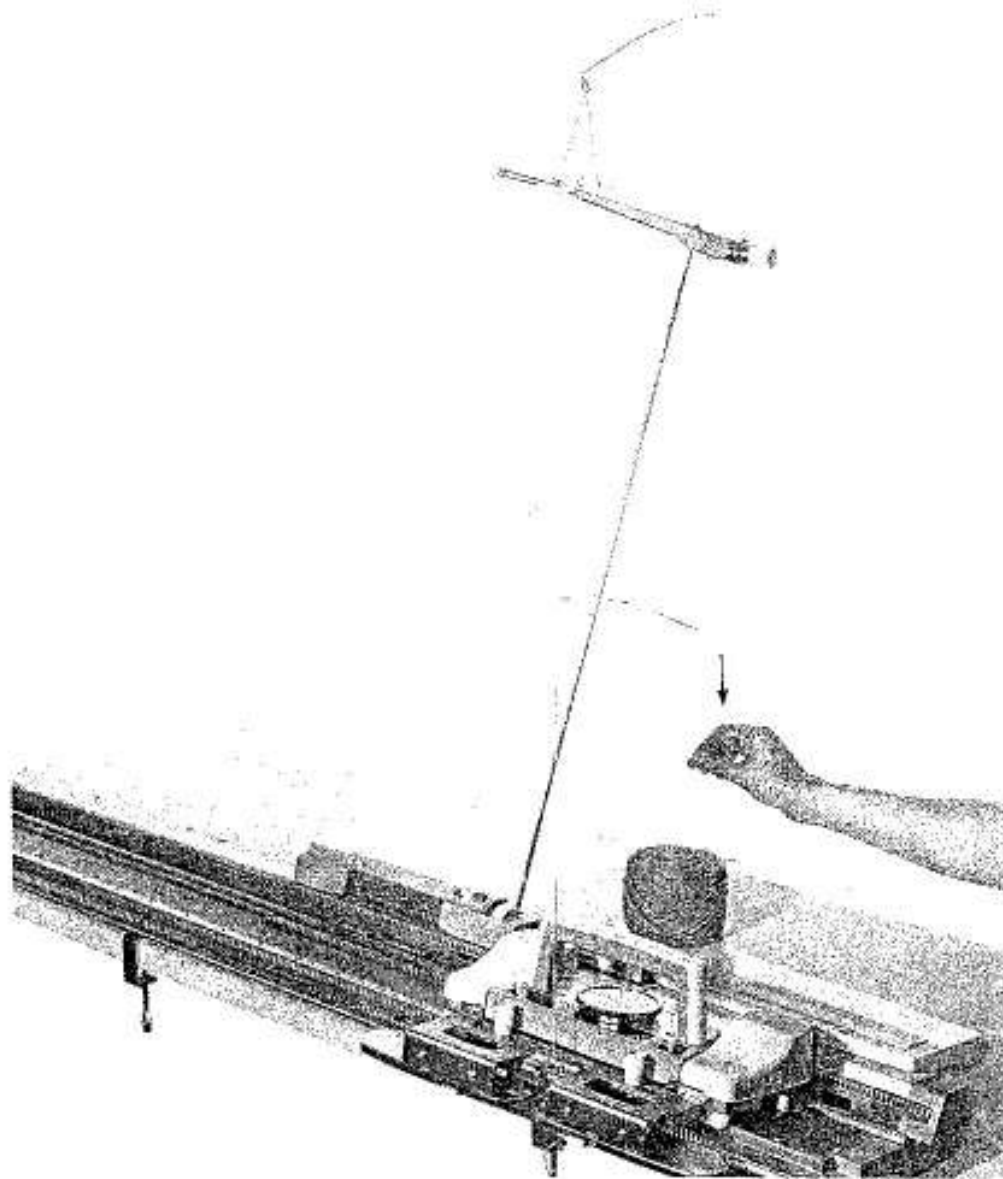

Pull the yarn down at the back of the Yarn Brake (as shown by the arrow), until all slack yarn has been taken up.

This will bring the Take-up Spring into a nearly horizontal position. There should NEVER be SLACK yarn BETWEEN the Table Clamp and the Yarn Brake.

When casting on, and while knitting, there should NEVER be any slack yarn BETWEEN the KNITTING and the Yarn Feeder. Be careful and you will avoid difficulties.

NOTE: If you knit with slack yarn, it will result in big loops or dropped stitches at the sides of your knitting.

YOU ARE NOW READY TO MAKE THE CAST-ON AND START KNITTING.

START CAST-ON

We will start knitting with an open edge cast-on. An open edge cast-on means an unfinished edge, therefore, if you pull on the knitting the stitches will run. But don't worry - later in the book you will learn how to make a closed edge cast-on.

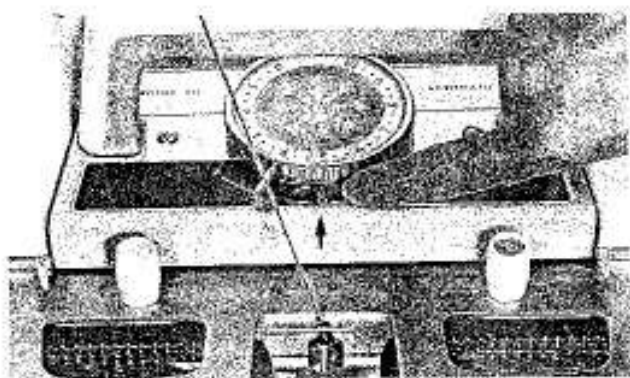

In the center of the carriage is the Stitch Tension Dial - numbered from 0 to 10 with points between the numbers. The Tension Dial gives you 30 different stitch sizes enabling you to knit nearly every type of yarn.

1. Turn the Tension Dial so that 7 is at the center front red triangle.
2. Side Levers to FRONT.
3. Cam Lever to center 0.
4. Front Levers to \downarrow .
5. Arm Levers to ∇ .

Now slide the carriage SLOWLY from RIGHT to LEFT until the center of the Yarn Feeder is on top of the LAST needles in knitting position.

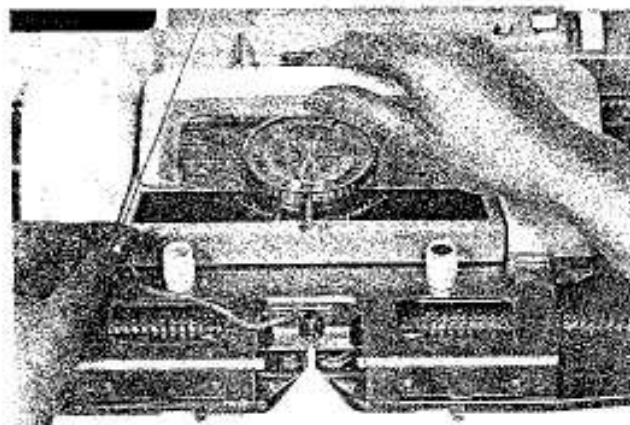

Pull down a little yarn from the Take-up Spring as shown, so that you have some slack yarn on top of the carriage. Continue moving the carriage to the LEFT, allowing it to use up the slack yarn, until the Sinker Arm plate is PAST the needles in knitting position, release the yarn.



THIS IS HOW YOUR CAST-ON SHOULD LOOK - ALL THE NEEDLES HAVE THE SAME SIZE LOOPS.

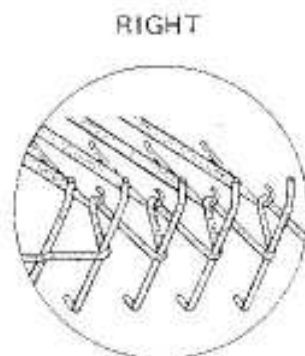

If your cast-on row looks like the above diagram, then you did NOT pull down enough slack yarn.

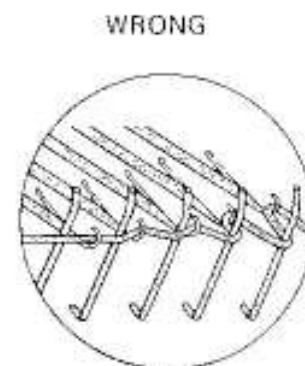

YOU ARE NOW MACHINE KNITTING

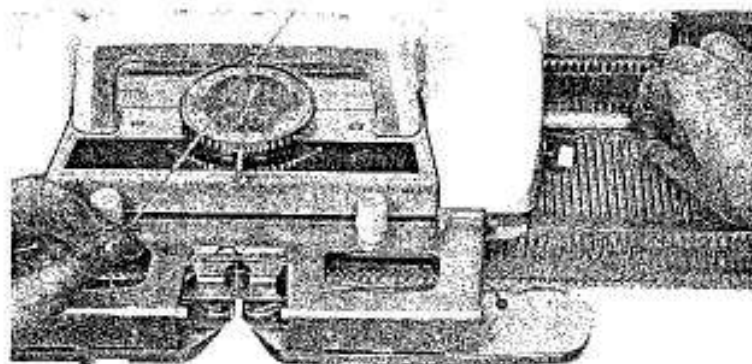

REMEDY for WRONG cast-on - pull down some slack yarn from the Take-up Spring with your left hand and hold it down, while with your right thumb, starting with the first small loop AT THE RIGHT push back, ONE by ONE the last few needles until ALL NEEDLES are in a line and have the SAME SIZE LOOPS.

The carriage is at the LEFT.

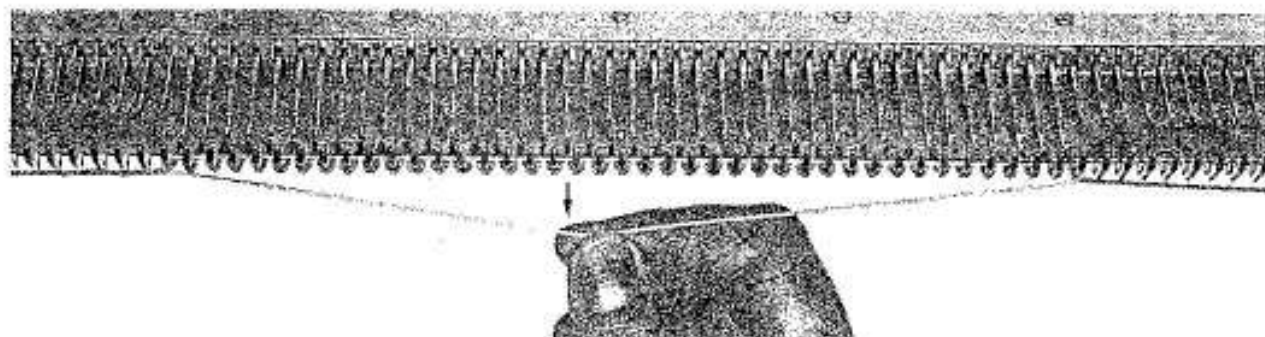

Pull down any slack yarn from BEHIND the Yarn Brake (Page 21). In your accessory case you will find a Nylon Cord. Open it and lay the center of this Cord across the yarn loops BETWEEN the needle hooks and the Sinker Gate pins. Hold BOTH ends TOGETHER and PULL FIRMLY DOWN so that the Nylon Cord comes BELOW the bottom level of the needle hooks.

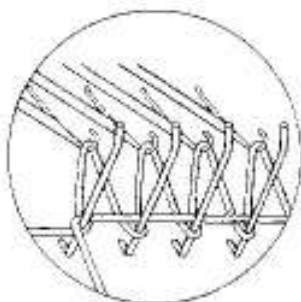

As you can see in the diagram, the Nylon Cord MUST pass AROUND the LAST Sinker Gate pin on each side of the cast-on. STILL PULLING THE NYLON CORD FIRMLY DOWN, move the carriage from LEFT to RIGHT until the Sinker Arm is past the needles in knitting position at the RIGHT.

In case you do NOT pull the Nylon Cord FIRMLY DOWN - the Nylon Cord will catch inside the needle hooks when moving the carriage across and you will have to cast-on again.

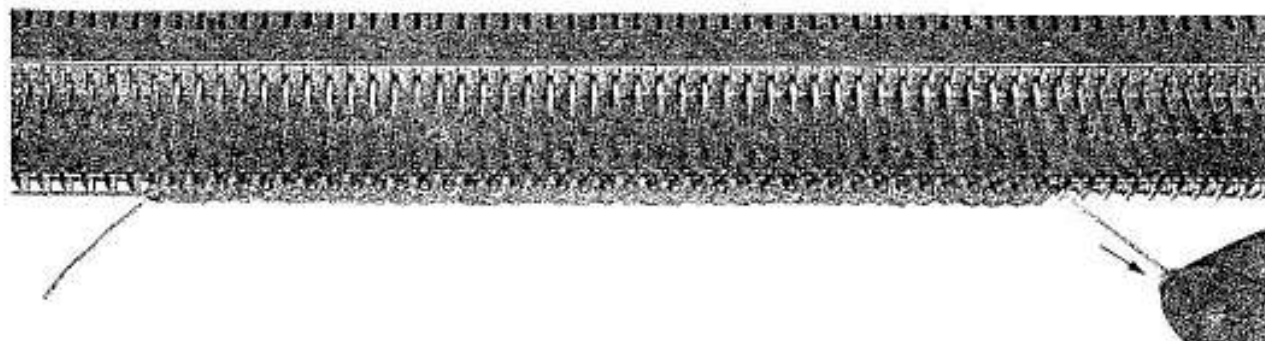

Move the carriage from RIGHT to LEFT and back, 4 rows (including cast-on) are knitted and the carriage is at the RIGHT side of the knitting. Let go the Nylon Cord, pull it OUT of the cast-on towards the RIGHT. Be sure you NEVER have knots in the Nylon Cord, otherwise you will NOT be able to pull it out of the knitting.

YOU ARE NOW MACHINE KNITTING

IF YOU HAVE HAD ANY DIFFICULTY IN KNITTING THE FIRST 4 ROWS, CHECK TO SEE IF -

1. The carriage ALWAYS passes ALL the needles in KNITTING position before returning to knit the next row.
2. The yarn is suitable for your Tension setting.
3. The yarn is threaded correctly.
4. The yarn is properly wound into a ball suitable for machine knitting.

Knit 20 or 30 more rows. This is the best way to get the right rhythm for knitting on your new machine and to gain confidence.

REMEMBER to ALWAYS move the carriage out of the needles in knitting position before changing the direction for the next row.

BUT - moving the carriage TOO FAR beyond the knitting results in loose yarn tension, and the yarn will tangle around the brushes below the Sinker Arm, in this case the carriage will jam or the yarn will break.

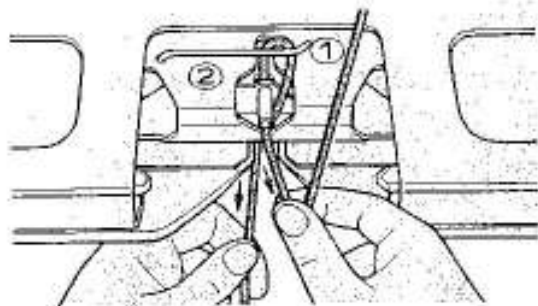

HOW TO REMOVE THE KNITTING WITHOUT CASTING OR BINDING OFF:

Remove the yarn from Yarn Feeder 1.

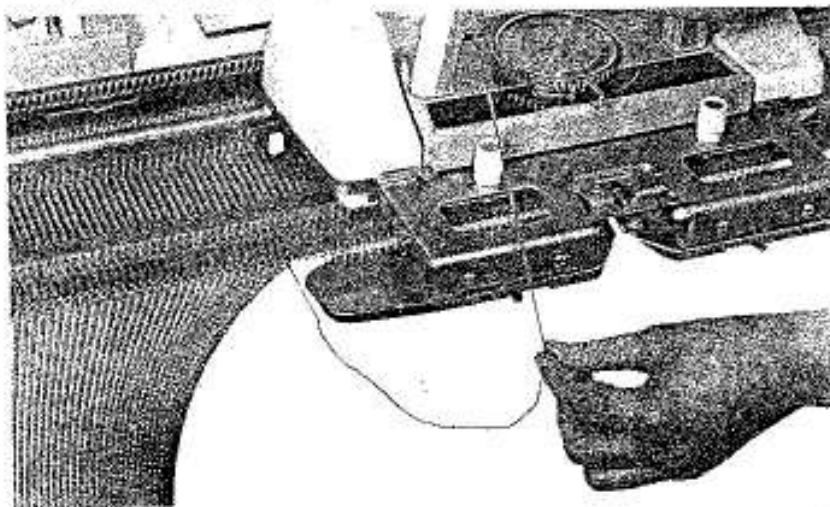

Hold the yarn AWAY and BELOW the carriage with your left hand, and with the right hand move the carriage FIRST to the RIGHT to release the yarn from the SINKER ARM, and . . .

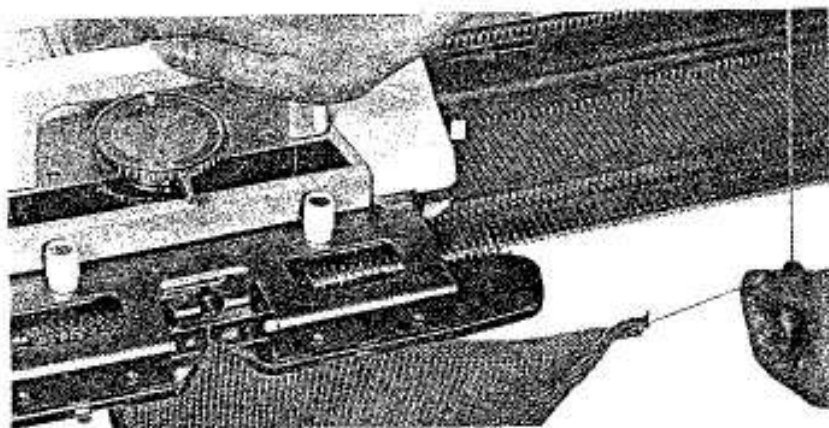

to the LEFT across the needles in Knitting position. The knitting automatically comes away from the needles because there was NO yarn in the Yarn Feeder.

The knitting will have an open edge. Later you will learn to cast or bind-off.

YOU HAVE NOW COMPLETED THE MOST IMPORTANT PART OF THE FIRST STEP IN KNITTING.

If you are not sure of all points, it is well worthwhile to go back to the beginning and start again. So, DO NOT hurry to the next page. Rather go through the FIRST section two or three more times. And if you encounter any problems, just look in the General Index for the correct answer.

THE AUTOMATIC CLOSED EDGE CAST-ON

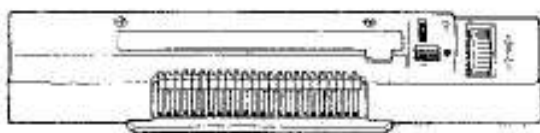

There are TWO different methods to make a closed edge cast-on — one is automatic and one is made by hand.

Card release is set to ● .

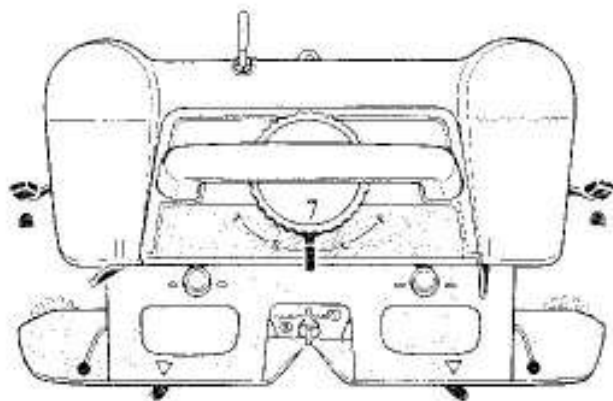

The carriage settings are:

1. Tension Dial to 7.
2. Side Levers to FRONT.
3. Cam Lever to center D .
4. RIGHT Front Lever I .
5. LEFT Front Lever II .
6. Arm Levers to ▼ .

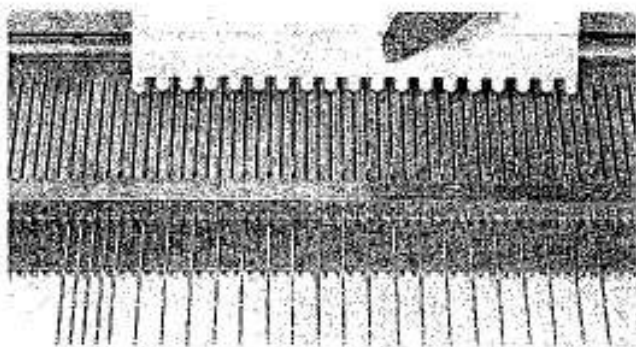

Using the straight edge Needle Pusher bring 22 needles at the LEFT and 21 needles at the RIGHT of center from A to D position. You have 43 needles in D position altogether.

Start with the SECOND needle from the RIGHT and push every SECOND needle back from D to A position, using the 1/1 side of the Needle Pusher.

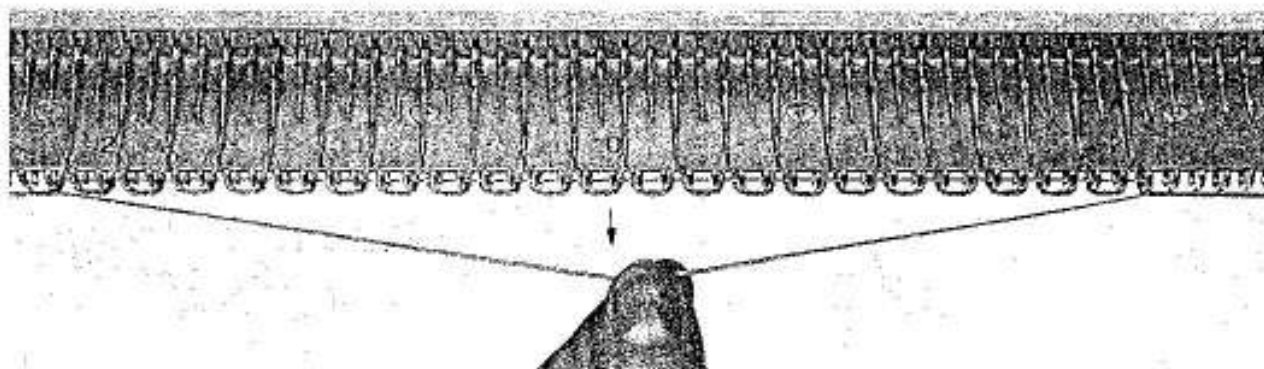

Thread the yarn through Feeder I. Knit 1 row to the LEFT. Every SECOND needle has a loop of yarn and the needles are knitted to B position. Lay the Nylon Cord across the loops and pull it FIRMLY DOWN. Set LEFT Front Lever to I.

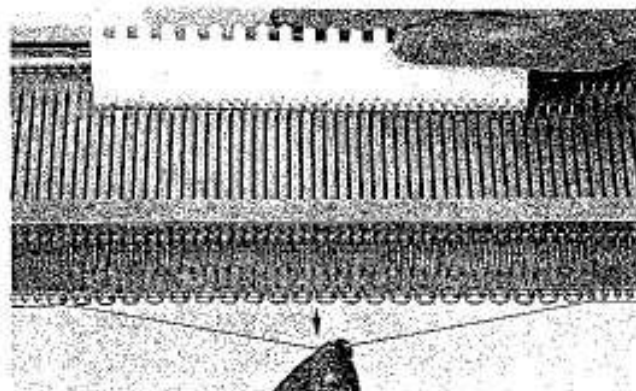

Still pulling the Nylon Cord down - with the straight edge Needle Pusher bring the rest of the 43 needles up from A to B position. This means in the same line as the needles with the loops.

Knit 4 rows. Pull the Nylon Cord out of the knitting.

Knit another 11 rows. Leave the carriage on the RIGHT side of the knitting.

With your first row you have knitted the AUTOMATIC closed edge cast-on.

THE CLOSED EDGE CAST-ON BY HAND

It is slower than the AUTOMATIC cast-on but gives a firmer edge. As it is often used, it is well worth learning. Set up the Pattern Panel and carriage the same as shown for the automatic cast-on at the top of the previous page.

Using the straight edge Needle Pusher, bring 40 center needles into D position. The carriage is at RIGHT.

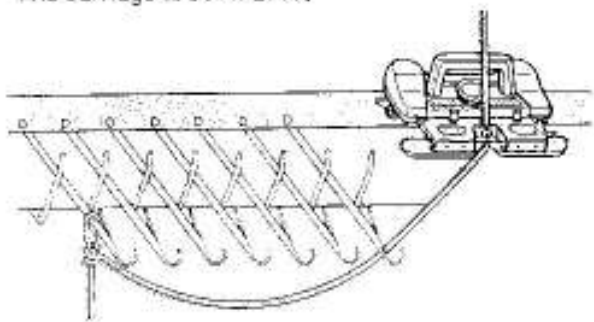

Make sure the LEFT Front Lever is set to II. Thread the yarn through Yarn Brake and Yarn Feeder. Pull sufficient yarn from BELOW the Yarn Feeder to tie a loose knot around the LAST needle at the LEFT side in D position.

IMPORTANT: ALWAYS start by winding the yarn around the needles from the OPPOSITE side of the carriage.



Wind the yarn LOOSELY around the needles in D position as shown by direction of arrow. As you wind a loop around a needle push it BACK against the Sinker Gate BEHIND the needle latch.

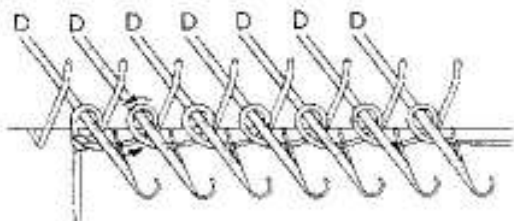

NOTE: When starting at LEFT, wind the yarn as shown. When starting at RIGHT (carriage at LEFT) wind the yarn clockwise.

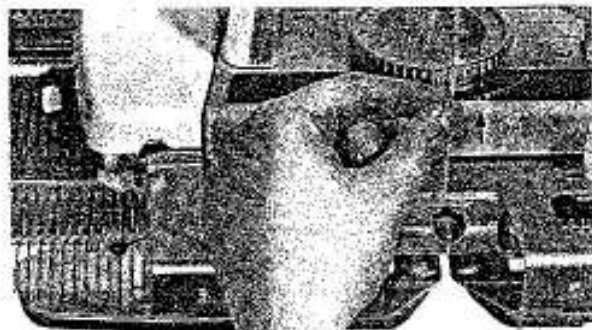

All needles have a loop. With your left hand hold the thread upwards on top of the Feeder, and with your right hand move the carriage to the LEFT - UNTIL the FIRST needles are knitted. Release the yarn and continue knitting to the LEFT, past the needles in knitting position. The needles are moved back to B position.

By holding up the yarn when starting the first row - you will avoid the thread tangling around the brush wheels.

Set LEFT Front Lever to I and continue knitting.

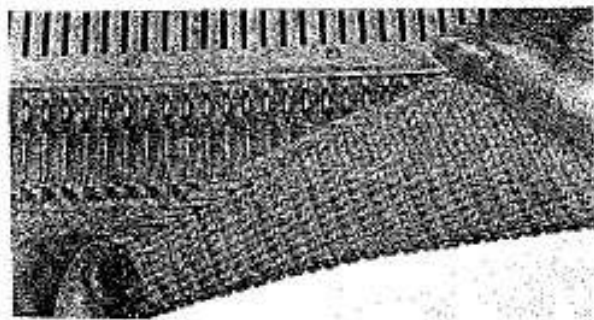

Usually you will knit several rows of waste yarn before you make the cast-on for a garment, as this will make the pinning out of the fabric much easier.

After the cast-on using waste yarn, still bring the needles to D position and proceed as above.

CASTING OR BINDING OFF WITH BIG LOOPS

This method of binding or casting off is **ONLY** suitable when using a thin to medium yarn as the last row is knitted at a **MUCH LOOSER** Tension than the rest of the knitting. Only bind or cast-off this way when your main Tension is 7 or less. Also, you can only cast-off or bind-off this way when you **CAST-OFF A COMPLETE ROW AT A TIME**. Another method will be shown later in the book.

Your carriage is at the **LEFT**. Set the Tension Dial to 10 and knit one row.

Break the yarn at the top of the carriage. Pull the yarn end **DOWN** and **OUT** of the Yarn Feeder. Always start casting off on the side of the needle bed opposite the carriage.

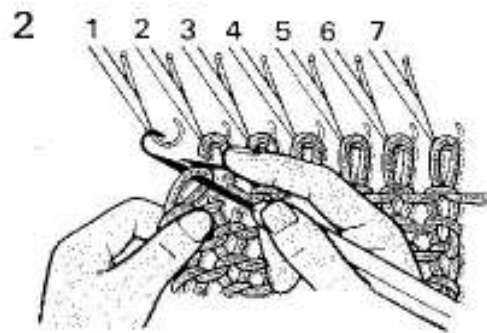
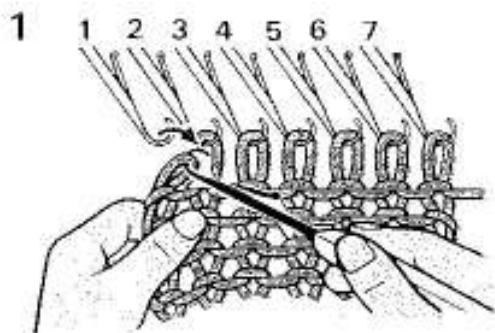

1. Insert the Latchet Tool in the **FIRST** stitch at the **LEFT** and lift it from its needle. Push the Latchet Tool forward and let the stitch slide **BEHIND** the latch.

2. With your forefinger hold the latch **DOWN**.

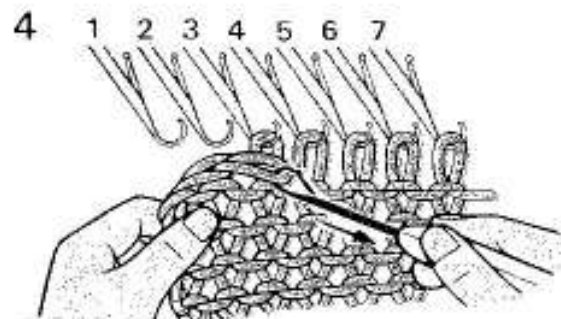
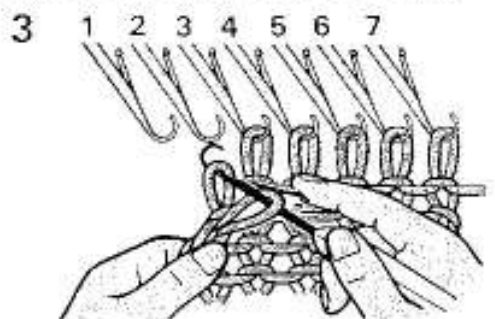

3. Remove the **SECOND** stitch from its needle, keep it **IN** the hook.

4. Lift up your forefinger and pull the Latchet Tool backwards, the **FIRST** stitch will slide over the closed latch and the **SECOND** stitch will be pulled through the **FIRST**.

Let the second stitch slide **BEHIND** the latch and hold the latch **DOWN**. Lift the **THIRD** stitch from its needle and pull it through the **SECOND** stitch.

Continue this way until the casting off of the whole row is completed.

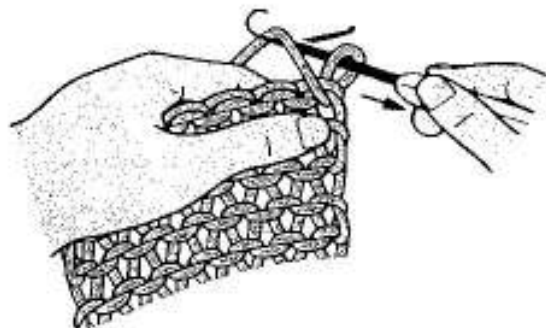

When you have the last loop in the Latchet Tool pull the rest of the yarn through the loop to bind-off the knitting completely.

NOTE: You can start casting or binding off from the **RIGHT**, but then you knit the last row with Tension 10 from **RIGHT** to **LEFT** and start binding off with the **FIRST** stitch on the **RIGHT**.

HOW TO JOIN YARN WHILE KNITTING

It is very easy to join a new ball of yarn in the middle of a piece. To practice, make an open edge cast-on over 40 needles and knit several rows; finish with the carriage at the RIGHT.

1. Break the yarn below the Yarn Brake.
2. Pull the yarn to the front and down below the Yarn Feeder.
3. Thread the end of the 'new' ball through the Yarn Brake and Yarn Feeder. Tie the end around the RIGHT side Table Clamp.
4. Continue knitting.

KNITTING STRIPES

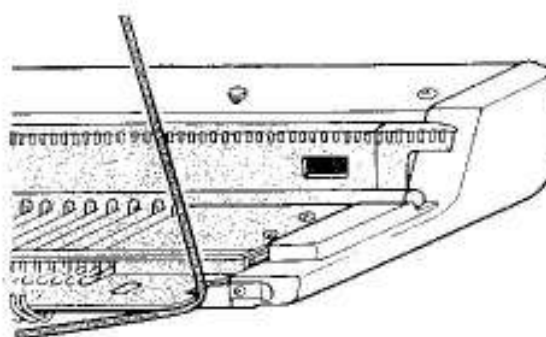
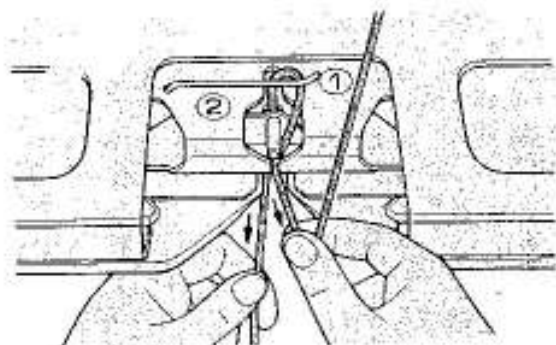

1. Wax and wind another ball of yarn (second color) for use with the machine.
2. Remove color 1 from the Yarn Feeder and hang it around the RIGHT side Yarn Clip.
3. Thread color 2 through the LEFT side of the Yarn Brake and Take-up Spring.
4. Pull the yarn inside the Yarn Feeder and fasten the end on to the RIGHT side Table Clamp. Knit 4 rows with color 2.
5. Remove color 2 from the Yarn Feeder and exchange with color 1 held round Yarn Clip at RIGHT. Thread color 1 through the Yarn Feeder. Color 2 is held by the Yarn Clip at RIGHT.
6. For practice, alternate colors three more times.

NOTE: When knitting stripes it is recommended to use same type and weight of yarn for all colors.

BLOCKING OR STEAMING A FABRIC

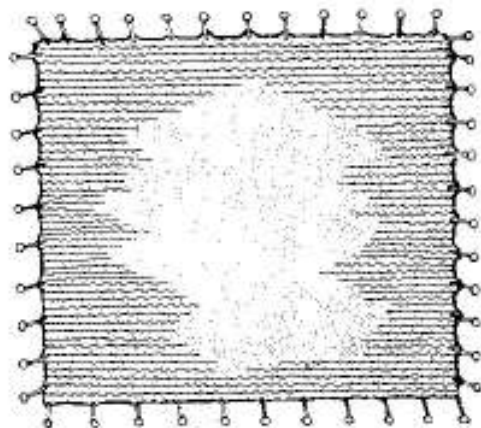

Lay the knitting on the ironing board - right side down - and WITHOUT STRETCHING, pin it out to the correct size using one pin every half inch, (1 cm).

Lay a damp or wet cloth on top of the knitting. Hold the hot iron just above the press cloth and let the hot steam penetrate into the knitting.

Remove the cloth and let the knitting cool and dry. Remove the pins. Careful steaming helps to give your garment that look of perfection.

CIRCULAR CORD KNITTING

THIS IS A VERY USEFUL TRIMMING FOR MANY NECKLINES.

IT HAS MANY OTHER USES AND IS VERY EASY TO KNIT.



Carriage is at the RIGHT side of the machine.
Card release is set to ●.

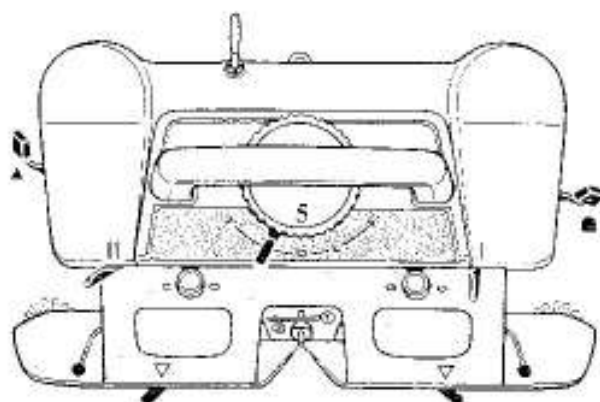

The Carriage settings are:

1. Tension Dial at 5,
2. RIGHT Side Lever to FRONT,
3. LEFT Side Lever to BACK,
4. Cam Lever to S,
5. RIGHT Front Lever to I,
6. LEFT Front Lever to II,
7. Arm Levers to ▼.

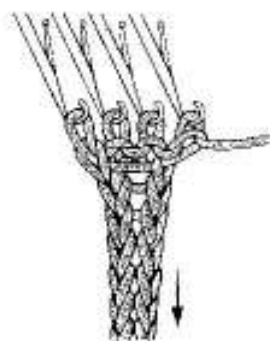
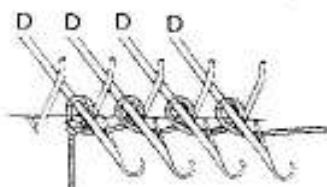

Bring 4 center needles from A to D position.
Thread yarn and make a knot around the
last needle in D position at LEFT.
Wind yarn around the 3 other needles.
Pull down any slack yarn from behind the
Yarn Brake.
Knit 1 row towards the LEFT. The needles
have been knitted to B position.

Move the carriage to the RIGHT past the 4
needles and the thread is in front of the Sinker
Gate. This is correct.
Continue knitting - always pulling lightly on
the cord at the same time.

HOW TO MAKE FRINGES

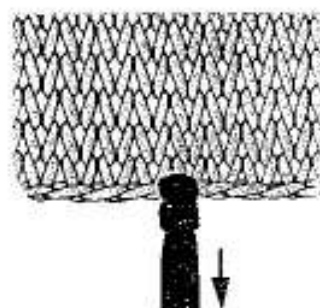

Take 4 or more threads, depending on the thickness of fringe you prefer, and cut them about 10 inches (25 cm) or longer according to taste.

Make your fringe as shown in diagrams 1 to 3, placing the threads as close together as you wish.
Trim the edges.

TENSION AND STITCH SIZES

JUST AS IN HAND KNITTING, IT IS IMPORTANT TO HAVE THE RIGHT STITCH SIZE FOR THE YARN THAT YOU USE. BECAUSE OF THE 30 STITCH SIZES ON YOUR MACHINE, YOU WILL FIND THAT YOU ARE ABLE TO USE ALMOST ALL OF THE POPULAR HAND KNITTING YARNS.

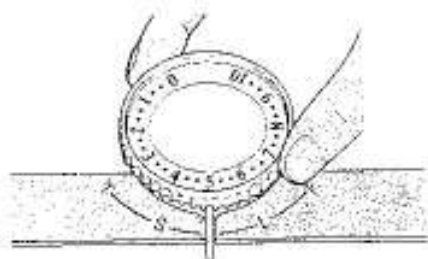

In the CENTER of the carriage is the Stitch Tension Dial. With the Tension Dial you can choose the size of stitch suitable for your yarn. Between the numbers you can see two little dots - these are also Tensions - this means that you can select from 30 different Tension sizes to find the most suitable for nearly any type of yarn you wish to knit.

You will see that most Stitch Patterns look far better when knitted with the correct Stitch Size. It is quite impossible for me to tell you here which is the best Tension for your yarns since there are too many different types. The following is a general Guide.

Yarn Type	Yarn Brake	Tension Dial
Lightweight	4 - 5	1 - 4
Medium	3	5 - 8
Heavy	1 - 2	9 - 10

It is very easy to find out for yourself which of the 30 settings is the best for you to use. To make a Test Swatch; make an open edge cast-on over 60 needles and knit a few rows on Tension 10. If you are using a lightweight yarn, you will find the stitches are much TOO LOOSE.

Set the Tension to 9 and knit a few rows. Repeat setting the Tension to a smaller size and knitting a few rows until you find a suitable Tension for the yarn you are using, and for the garment you are making.

Remember that a sweater is usually knitted at a Tension one or even two points LOOSER than you would use for a skirt. The reason is that a sweater is comfortable when it has more stretch, but a skirt will stretch out of shape unless the Tension is a little TIGHTER.

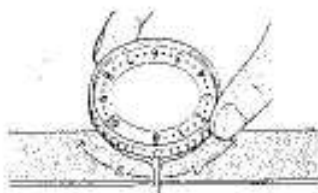

When the Tension Dial is set to 0 - the TIGHTEST Tension is obtained (smallest stitch).

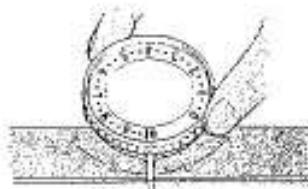

When the Tension Dial is set to 10 - the LOOSEST Tension is obtained (largest stitch).



IF YOUR TENSION IS TOO TIGHT - it will be difficult, or even impossible to knit and you will use more yarn, thus wasting money and your knitwear will be hard and uncomfortable to wear.

IF YOUR TENSION IS TOO LOOSE - your knitted garment will either have no shape or will very soon lose its shape.

INCORRECT TENSION SETTING CAUSES

1. JAMMING OF THE CARRIAGE
2. VERY HARD KNITTING
3. WASTAGE OF YARN IF THE TENSION IS TOO TIGHT
4. FAULTY PATTERNS
5. DROPPED STITCHES
6. SHAPELESS GARMENT IF THE TENSION IS TOO LOOSE

HOW TO MEASURE A TENSION SWATCH

To make sure your garments will fit perfectly, it is always necessary to make a Tension Swatch. You must first test to see which Tension number is suitable for the yarn, as described on the previous page.

With your chosen Stitch Size, make an open edge cast-on over 60 needles and knit 60 rows. Remove the knitting from the machine.

Pull the swatch slightly in the lengthwise direction to enable the stitches to close up slightly.

Leave the swatch for at least an hour. Then pin the swatch on to an ironing board, rightside up.

In this swatch we count: 31 stitches to 10 cm = 4 inches,
43 rows to 10 cm = 4 inches.

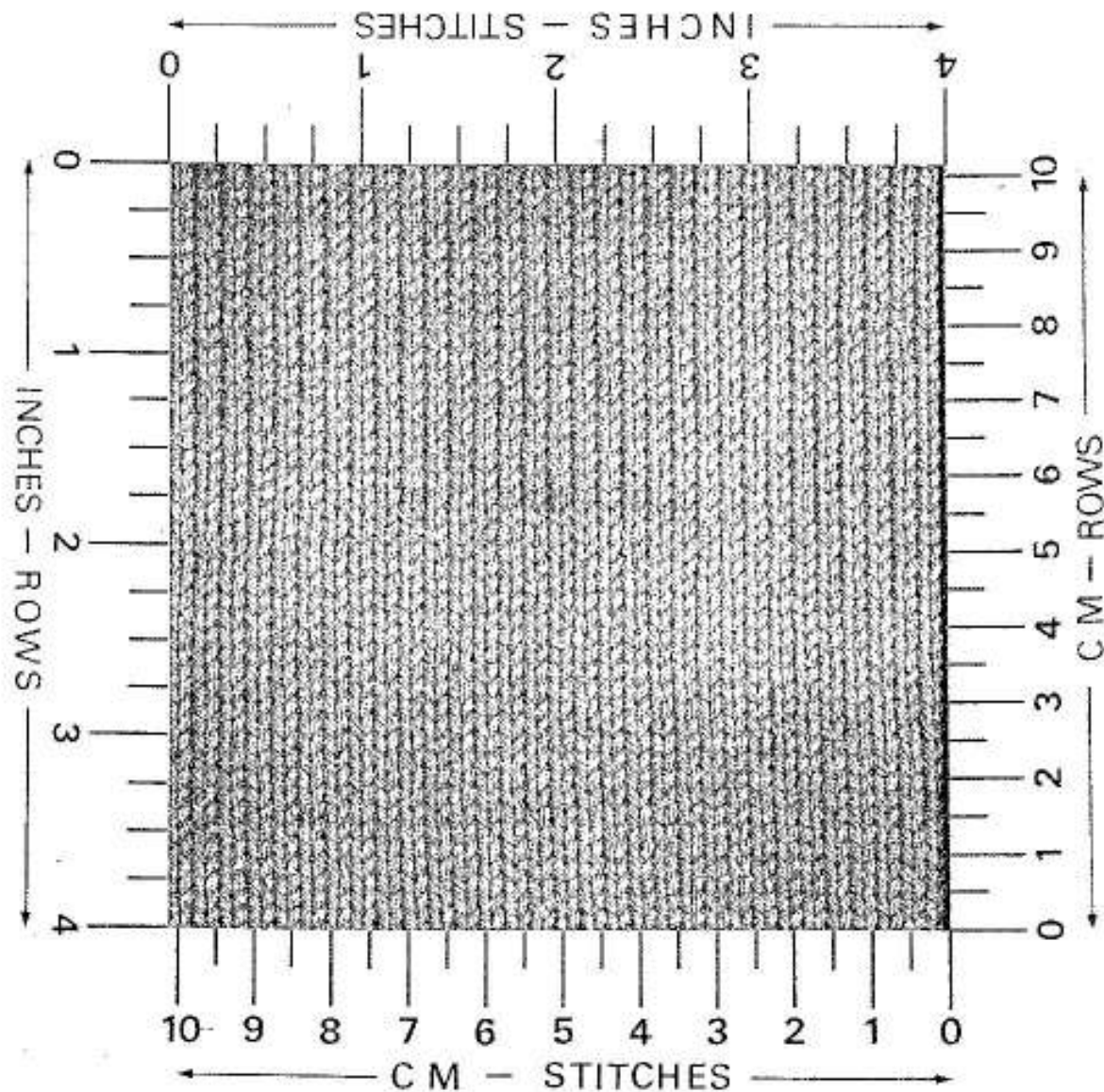

GRAFTING

Quick and easy to do and it is used for sewing together almost any type of open edge knitting.

After a little practice you will graft stitches together so well that you cannot afterwards see where your knitwear has been joined.

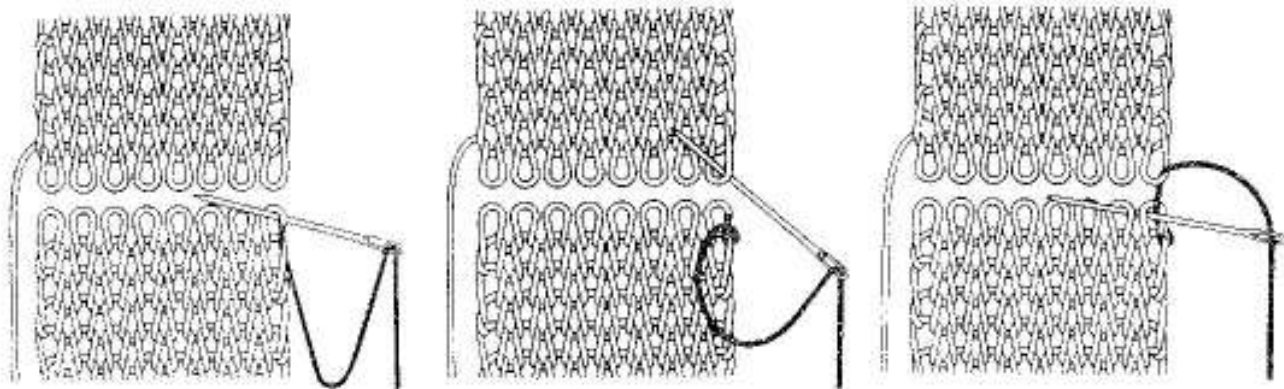

You need a thread of your knitting yarn about 3 times longer than the width of your knitting.

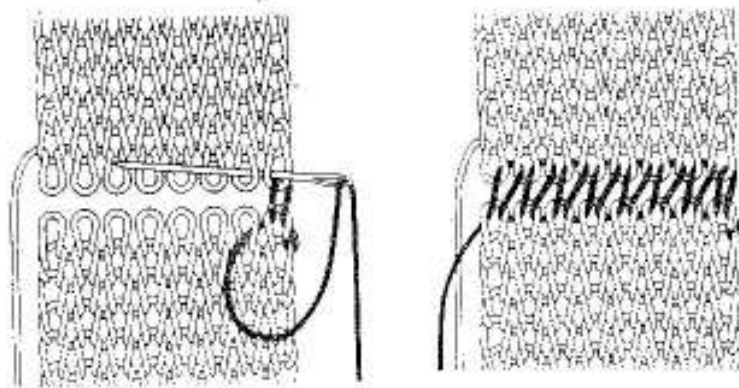

SEWING UP HEMS

OPEN STITCHES

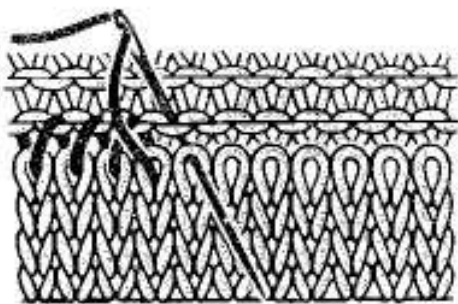

After steaming the fabric, unravel the waste yarn and fold up the required length. Catch down the open stitches using a thread of knitting yarn. Take care to join the hem to the same row of knitting otherwise the hem will not be straight.

CLOSED STITCHES

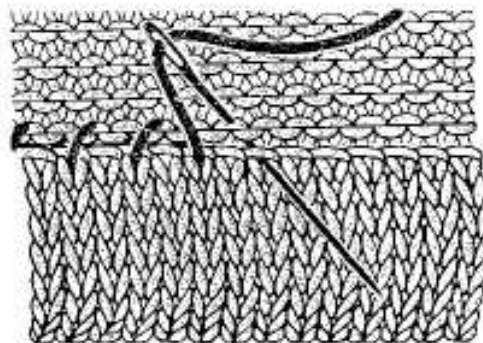

Fold up the required length of hem. Take care to join the hem to the same row of knitting, otherwise your hem will not be straight.

THE MATTRESS STITCH



1. The red stitches at the edges of the drawing are the stitches used for the seam.
2. Thread a tapestry needle with knitting yarn.
3. Take the bars of the first 2 rows on the side of the end stitch and pull through, second diagram.
4. Take the bars of 2 rows next to the end stitch of the second piece, as shown in third diagram.

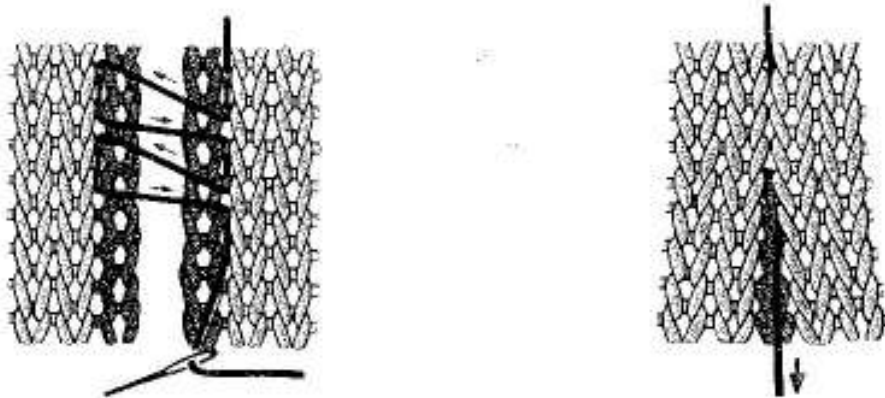

5. Continue taking 2 bars next to the end stitch alternatively 2 or 3 times.
6. Hold the fabric at the wrong side by the seam and pull the sewing thread tight, this will close up the stitches and leave an invisible seam at the right side.

THE BACKSTITCH

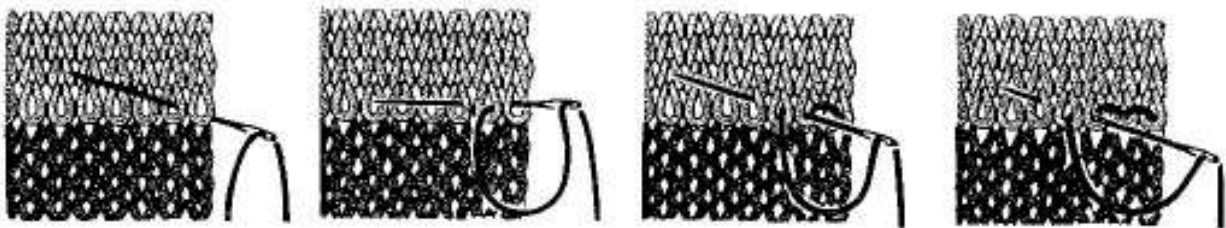

1. Thread tapestry needle with main yarn and, starting at seam edge, bring the needle upwards through second stitch.
2. Insert needle from-top into first stitch and through knitting and bring up through third stitch.
3. Insert from top through second stitch, through knitting and up through fourth stitch.
4. Repeat this backstitch for practice.

HOW TO MAKE A CORD

Cut threads, usually 6-8, about 3 times longer than the final length of cord required. Hold them together and make a knot on each end. Place one end over a hook, and a pencil through the other end. Hold fast and twist the pencil in one direction, until the cord is very tight and starts to twist over itself. Then pull it straight. Hold firmly and now fold the cord in half. The cord will now twist itself. Make a knot about 2 inches (5 cm) from each end. Cut open the threads at both ends to make a tassel.

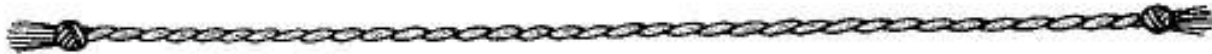

POM PONS

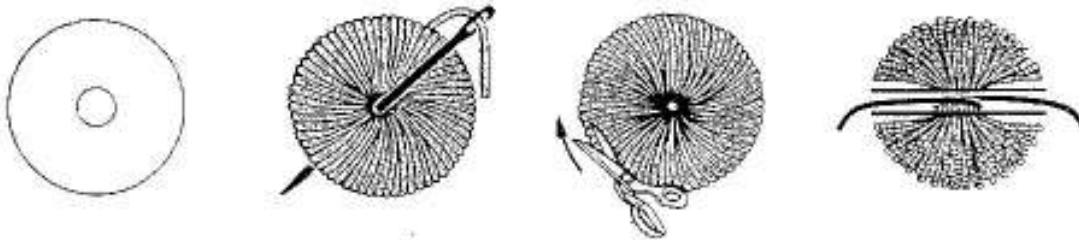

1. Cut 2 circles of cardboard to the size you wish the pom-pom to be. Make a hole in the center of each piece of cardboard about $\frac{1}{4}$ inch across. Put them both together.
2. Thread a tapestry needle using yarn for pom-pom. Sew around both cardboards tightly until the center is completely full and you are not able to put the needle through anymore.
3. Cut the threads around the outside of the circle. Separate the circles SLIGHTLY.
4. Take a thread about 14 inches long and wind it tightly, 2 or 3 times, around the center of the threads between the cardboard discs. Tie with a double knot.

Break the cardboard discs to remove them from the yarn. The pom-pom is ready. The loose ends of thread are used to sew the pom-pom on to the garment or cord.

If you wish the pom-pom to have several colors, just change the color of the thread inside the tapestry needle.

FINISHING METHODS

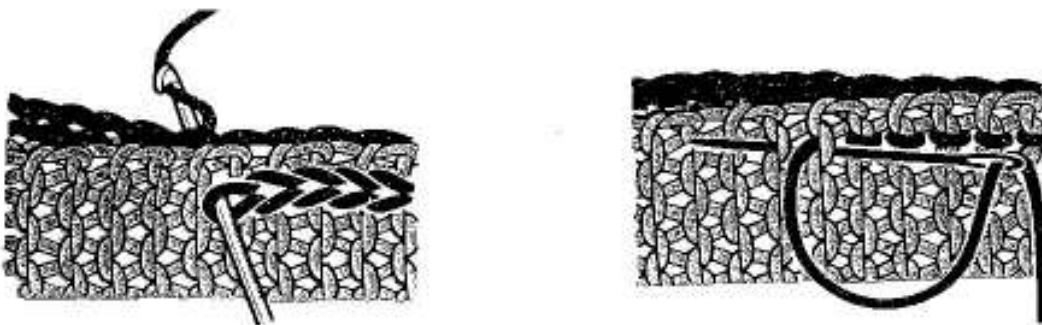

More methods of finishing your garments.

Instead of the Mattress Stitch, you can join the seams either by crocheting or backstitching the two pieces together.

KNITTING



STEP

2

Making a Hem	36 - 38
Pivot Hem	39
Simple Increasing and Decreasing	40 - 41
How to make welts	42 - 62
Fully Fashioned Increasing and Decreasing	53 - 55
Shaping a V neck in plain knitting	56 - 58
Shaping a V neck in Stitch Pattern	59
Slit for Zip Fastener	58
Round neckline (Method 1) in plain knitting and Stitch Patterns	60 - 62
Round neckline (Method 2) in plain knitting and Stitch Patterns	63 - 66
Pocket in plain knitting	67 - 68
Pocket in Stitch Patterns	69
Collars in plain knitting and Stitch Patterns	70 - 71
3 Methods for shoulder shapings	72
Buttonholes	73 - 78
Hints	80

KNITTING A HEM

When knitting a hem always start by knitting the first few rows using waste yarn. By waste yarn, I mean any lightweight yarn other than that being used for the garment.

When knitting hems or welts, the waste yarn is removed after closing the hem.

Thread your machine with waste yarn and make an open edge cast-on over 40 needles. Knit several rows, finishing with the carriage at the LEFT.

Break the waste yarn above the carriage and pull the end downwards out of the Yarn Feeder. Remove the waste yarn from the Yarn Brake.



Card release is set to ●.

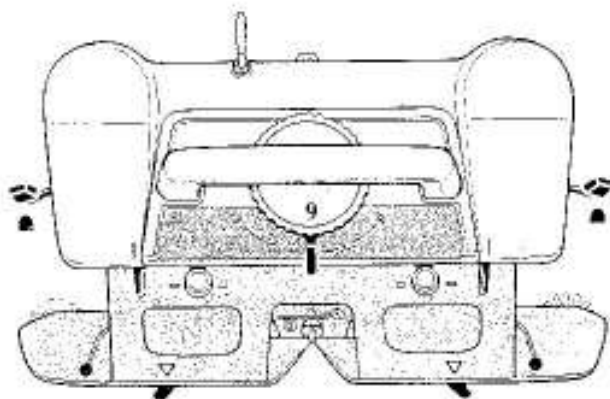

Carriage settings are:

1. Set Tension Dial to 9.
2. Side Levers to FRONT.
3. Cam Lever to center 0.
4. Front Lever to I.
5. Arm Levers to ▽.

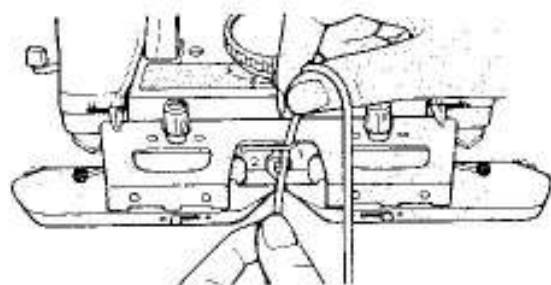

Take the Nylon Cord and feed it DIRECTLY into the Yarn Feeder, allowing 2 or 3 inches (8 cm) to hang down below the carriage.

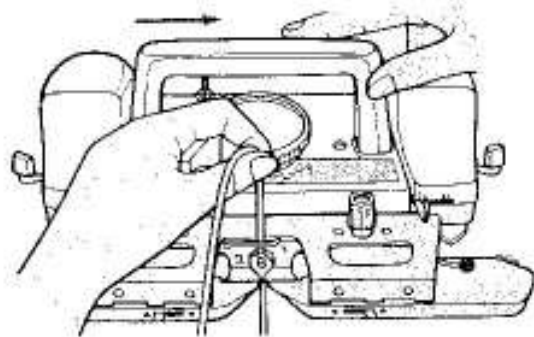

Allow the Nylon Cord to hang over your thumb as shown, and hold it lightly between thumb and forefinger. Knit 1 row towards the RIGHT. While moving the carriage - let the Nylon Cord slide smoothly through your fingers as the carriage needs it to make the stitches.

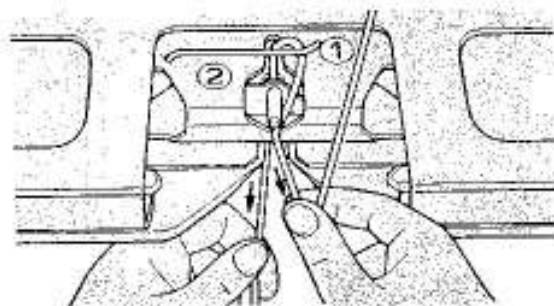

Pull the remaining length of Nylon Cord down and out of the Yarn Feeder and let it hang down from the side of the knitting.

The Nylon Cord is knitted in to separate the following hem from the waste yarn.

KNITTING A HEM

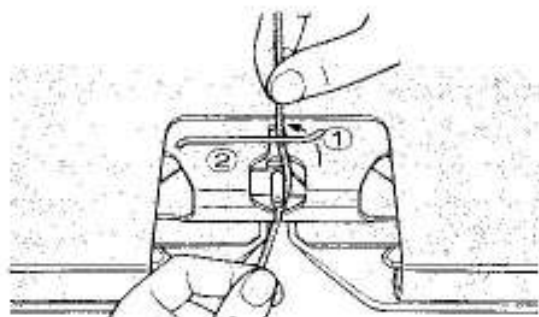

The hem is usually knitted with a smaller Tension size than the rest of the garment. This gives more elasticity so it cannot stretch out of shape.

The carriage is at the RIGHT. Thread the main yarn through the Yarn Brake and Yarn Feeder and fasten the end on to the RIGHT hand Table Clamp. Pull down any slack yarn from behind the Yarn Brake.

Set the Row Counter to 000.

Knit 1 row with Tension 7 - Row Counter reads 1.
Knit 7 rows with Tension 5 - Row Counter reads 8.
Knit 1 row with Tension 7 - Row Counter reads 9.
Knit 8 rows with Tension 5 - Row Counter reads 17.
Set Tension back to 7.

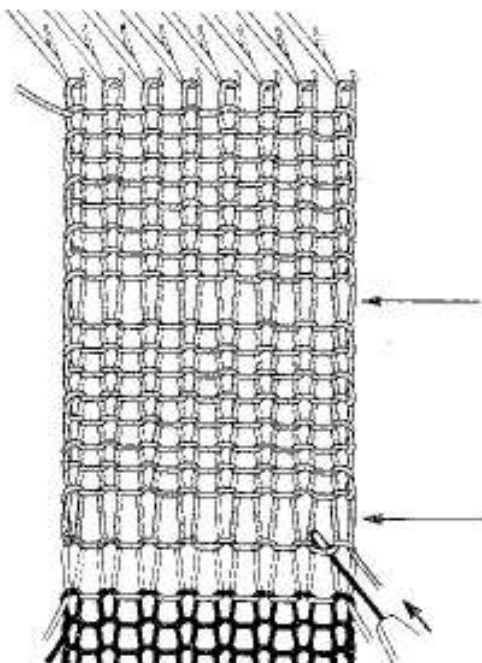

These large stitches help to make a neat, flat edge when the hem is folded.

These large stitches will make it easier to close the hem.

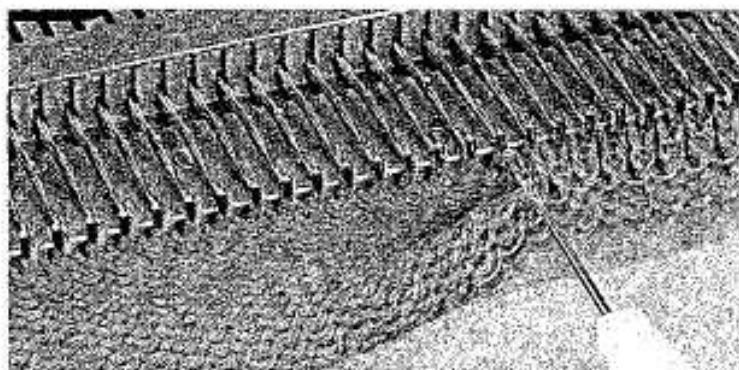
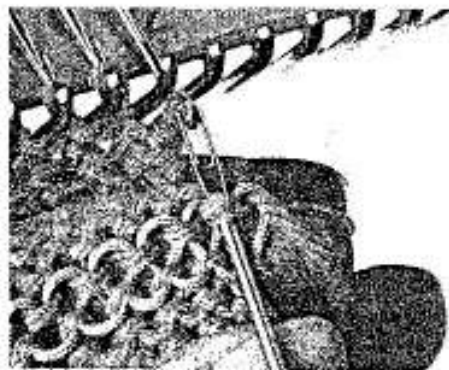

1. With the brush, open the latches. Fold the hem at the center and hold the first row knitted with main yarn over your forefinger.

Slip the Transfer Tool UNDER the FIRST LOOP from the RIGHT, of the FIRST row knitted AFTER the Nylon Cord. Hook the Transfer Tool into the FIRST needle from RIGHT. Raise the Transfer Tool and let the loop slide DOWN into the needle hook. This needle now has TWO loops.

2. Lift into the needle hooks ALL loops of the FIRST row knitted after the Nylon Cord. When this is completed, each needle in B position will have two loops except for the last one at the LEFT.

After a little practice you will be able to lift up 2 or 3 loops at a time using the double or triple Transfer Tool.

KNITTING A HEM

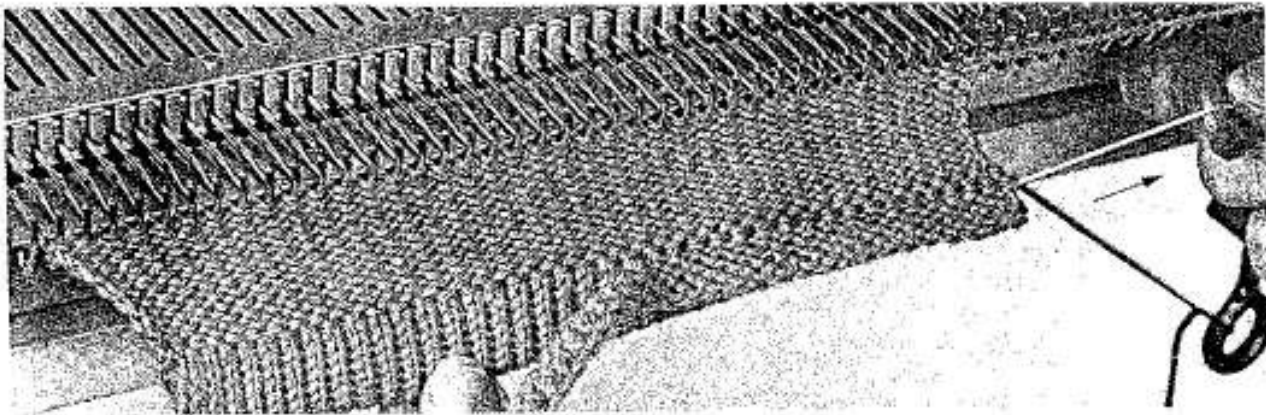

Pull all working needles back into B position and knit several rows.

Hold the knitting with your LEFT hand and pull the Nylon Cord out to the RIGHT. The first rows knitted with waste yarn will fall away from the knitting, leaving a perfect hem.

NOTE: When you are knitting with heavy yarn and your hem has been lifted, it is easier to close if you use this procedure; hold the knitting against the machine and with the straight edge Needle Pusher bring the needles from B to D position.
When the carriage is at the RIGHT, set LEFT Front Lever to II.
When the carriage is at the LEFT, set RIGHT Front Lever to II, and continue knitting.

TRANSFERRING STITCHES WITH THE TRANSFER TOOL

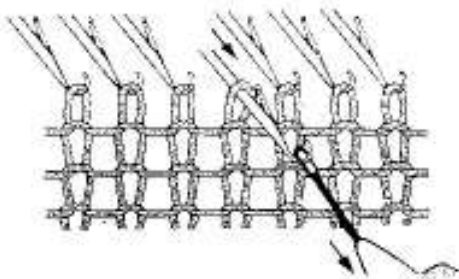

The Transfer Tool has many uses but is mainly used for transferring stitches, increasing and decreasing and for fancy pattern making.

Place the eye of the Transfer Tool on to the needle hook. Pull the needle towards you from B to D position.

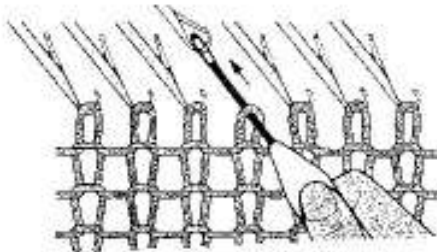

Push the needle back to A position, causing the stitch to slide over the needle latch on to the Transfer Tool. Lift the Transfer Tool out of the needle hook.

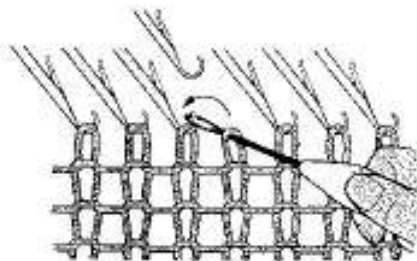

Place the Transfer Tool in the hook of the adjacent needle. Hold the knitting down and lift the handle of the Transfer Tool until the stitch slides down into the needle hook.

THE PICOT EDGE HEM



The picot edge hem has an attractive scalloped edge. It is very similar to the hem which you have just completed.

With waste yarn make an open edge cast-on over 40 needles; knit several rows finishing with the carriage at the LEFT. Remove the waste yarn.

Knit in the Nylon Cord towards the RIGHT. Knit 7 rows with main yarn. Carriage is at LEFT. Open all needle latches.

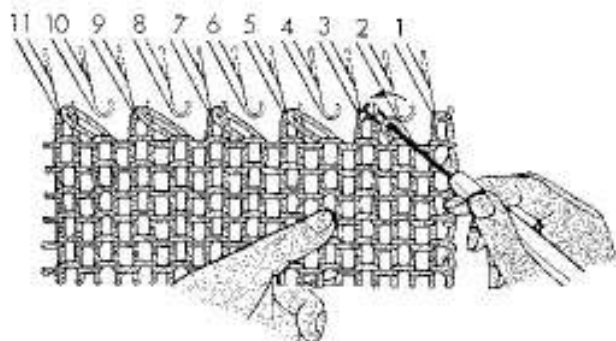

Transfer the stitch from needle 2 to needle 3. Then transfer the stitch from needle 4 to needle 5.

Continue transferring the stitches across the row until every other needle has TWO stitches. The empty needles remain in B position.

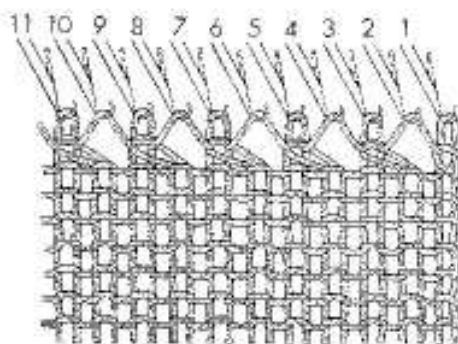

Knit 1 row towards the RIGHT. The needles which had no stitches now have loose loops. Knit another 7 rows. Carriage is at LEFT.

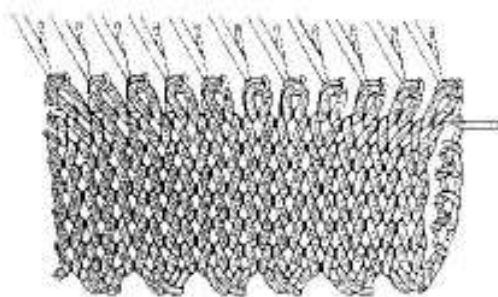
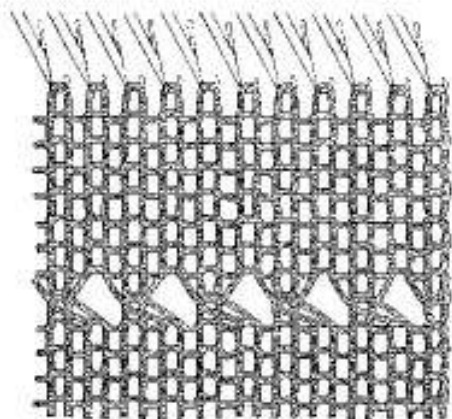

To close the hem, lift on to the needles the loops of the FIRST row knitted with main yarn after the Nylon Cord as you did for the plain hem. Knit 1 row and pull the Nylon Cord out of the knitting to remove the waste yarn.

INCREASING ONE STITCH AT A TIME

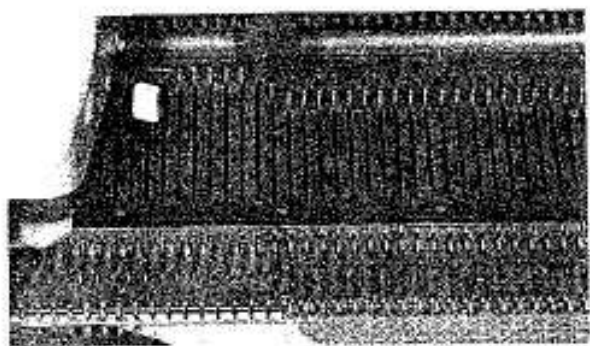

If you wish to increase ONE stitch on the LEFT side - your carriage must be at the LEFT.

Push the next empty needle on the LEFT side of the knitting from A to B position. Continue knitting.

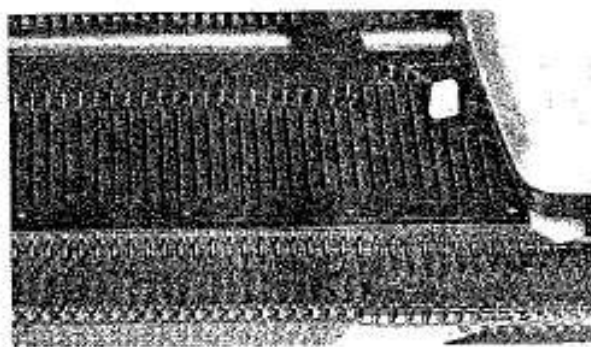

If you wish to increase ONE stitch on the RIGHT side - your carriage must be at the RIGHT.

Push the next empty needle on the RIGHT side of the knitting from A to B position. Continue knitting.

INCREASING MORE THAN ONE STITCH AT A TIME



TO INCREASE SEVERAL STITCHES ON THE RIGHT SIDE –
THE CARRIAGE MUST BE AT THE RIGHT.

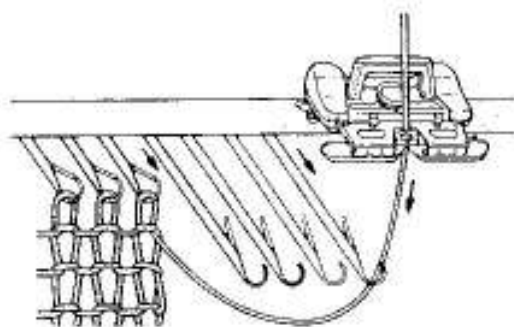

Set LEFT side Front Lever to II.

To increase 4 stitches at the RIGHT - push 4 extra needles from A to D position on the RIGHT side.

Pull some yarn downwards through the Yarn Feeder.

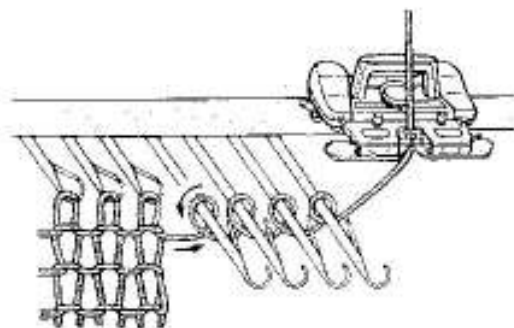

Wind the yarn L-O-O-S-E-L-Y UNDER and AROUND every needle as you did for the closed edge cast-on.

Pull down any slack yarn from the Yarn Brake. Knit 1 row.

You will notice that you have increased 4 stitches on the RIGHT side of the knitting.

TO INCREASE SEVERAL STITCHES ON THE LEFT SIDE —
THE CARRIAGE MUST BE AT THE LEFT.

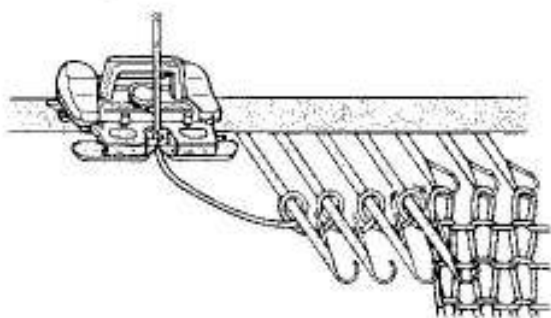

To increase 4 stitches at the LEFT - push 4 extra needles from A to D position on the LEFT side.

Wind the yarn L-O-O-S-E-L-Y around the 4 needles in clockwise direction as shown by the arrows. Set RIGHT side Front Lever to II.

Pull down any slack yarn from behind the Yarn Brake and knit 1 row. You have now increased 4 stitches on the LEFT side of the knitting.

DECREASING ONE STITCH AT A TIME

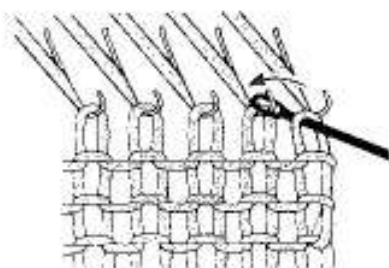

You can decrease 1 stitch on both sides of the SAME ROW.

Transfer the last stitch on each side on to its adjacent needle.

Push the EMPTY needles BACK to A position. Continue knitting as before.

DECREASING MORE THAN ONE STITCH AT A TIME

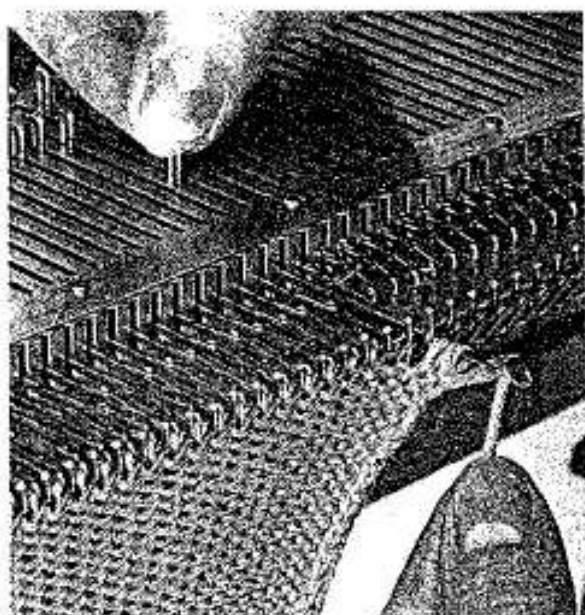

When the carriage is at the RIGHT:

1. Transfer the stitch from the LAST needle on the RIGHT on to the adjacent needle at its LEFT. Push the needle with 2 stitches up to D position.
2. Leave the empty needle in B position.
3. With your LEFT thumb, push the needle with the two stitches carefully from D to C position. The latch MUST remain OPEN.
4. Pull a little yarn from the Feeder and lay it from RIGHT to LEFT across the open hook, as shown.
5. Holding the needle by the butt, pull it BACK to B position.
6. Repeat steps 1 to 5 until the required number of stitches have been decreased.

When this is completed, bring the empty needles BACK to A position. Leave the empty needles in B position while decreasing because it is easier to count the decreased stitches.

NOTE: To decrease at the LEFT, the carriage must be at the LEFT.

CASTING OR BINDING OFF

You can decrease AS MANY stitches AS YOU WANT in the method described above - - including binding off completely.

Follow steps 1 to 5, continuing until one loop remains in the last needle. Break the yarn above the carriage and pull the end out of the Yarn Feeder. Draw it through the last loop to lock the stitches.

THE NEW WAY TO MAKE RIBBED WELTS

THE AUTOMATIC SYSTEM FOR KNITTING PERFECT DOUBLE WELTS.

Double to give a perfect, snug fit, and more elastic than ever before.

Double hems last much longer too, and - they are SO easy to knit.



These are some of the hems with ribbing effect that you can knit.

1 by 1 ribbing effects are most suitable when you are knitting with medium to thick yarns using Tension 6 and higher.



2 by 1 ribbing effects - very suitable and useful for every type of yarn and all Tensions from 2 upwards.



3 by 1 - Can also be used for all yarns using Tensions from 2 upwards, but it is most attractive and elastic when knitted in a fine soft yarn using Tensions between 2 - 4.

THE 1 BY 1 DOUBLE WELT

In order to make perfect welts - elastic, neat and durable - it is most important to knit them with the correct Tension. Every yarn is different but in principle the Tension used for the 1 by 1 welt is set about 3 to 4 numbers lower than the yarn would usually be knitted.

The carriage is at the RIGHT. Bring 22 needles at the LEFT and 21 needles at the RIGHT of center 0 from A to B position.

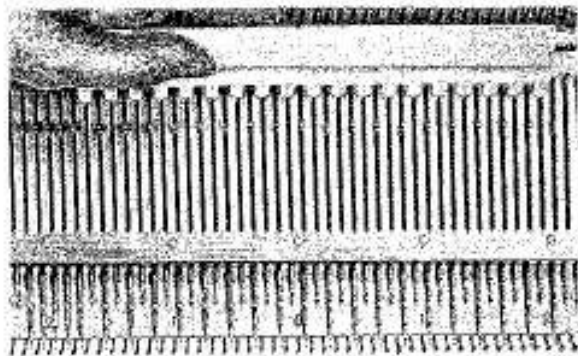

Starting with the SECOND needle from the RIGHT, bring every SECOND needle BACK to A position using the 1 / 1 side of the Needle Pusher.

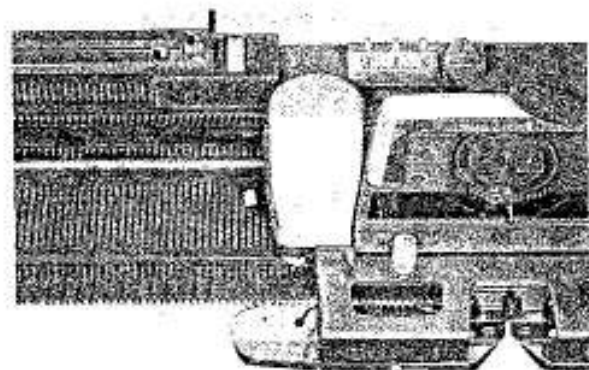

Card release is set to ● .

Carriage settings are:

1. Tension Dial to 7,
2. Side Levers to FRONT,
3. Cam Lever to center 0 .
4. Front Levers to 1 .
5. Arm Levers to ▽ .

Slide the carriage to the LEFT and back to the RIGHT across the needles to ensure that they are clear and ready for the cast-on.

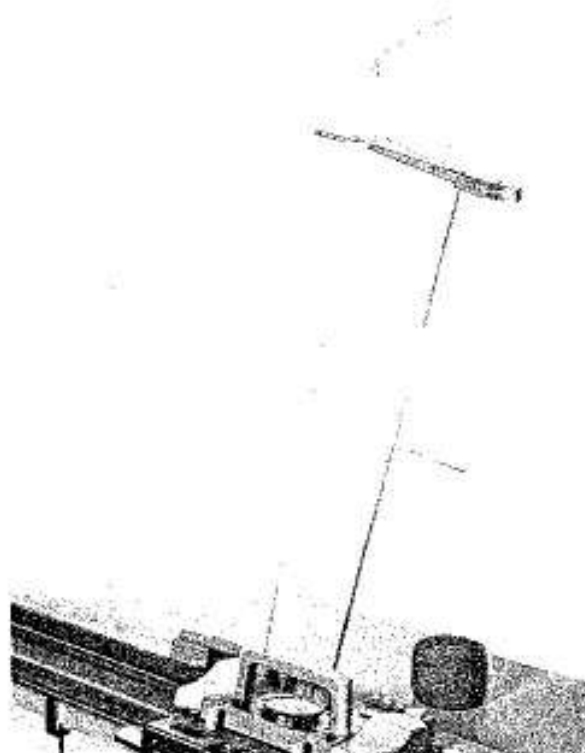

Thread up the waste yarn through the Yarn Brake and the Yarn Feeder, pull down any slack yarn from behind the Yarn Brake.

Remember there must NOT be any slack yarn between the Yarn Feeder and the Table Clamp.

KNITTING THE 1 BY 1 DOUBLE WELT



The carriage is at the RIGHT.
Knit 1 row towards the LEFT.

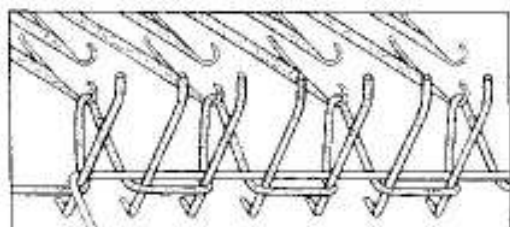

Lay the Nylon Cord across the loops
between the needle hooks and the
Sinker Gate.

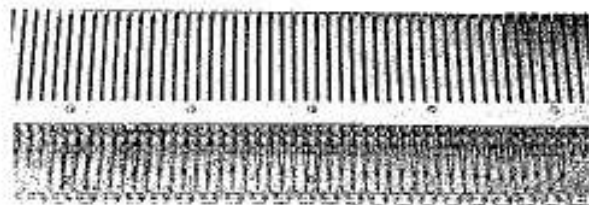

Pull the Nylon Cord FIRMLY DOWN.

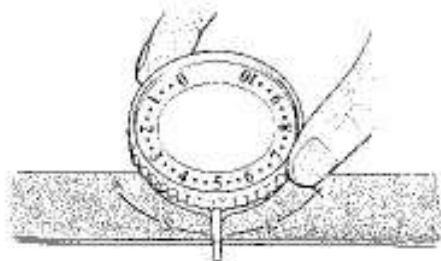

Turn the Tension Dial ring to 5 and
knit a few more rows finishing with
the carriage at the LEFT.

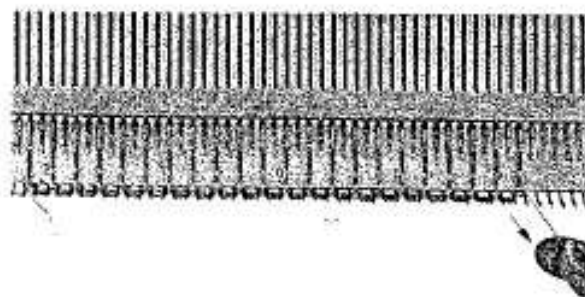

Pull the Nylon Cord out of the knitting.

KNITTING THE 1 BY 1 DOUBLE WELT

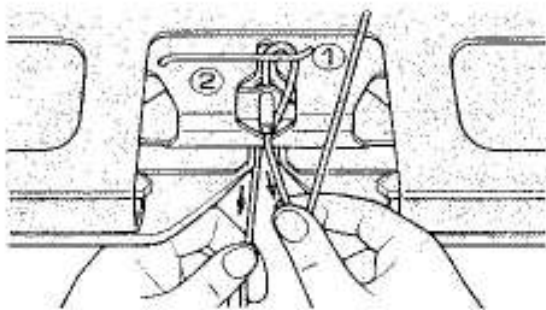

Remove the waste yarn from the Yarn Feeder and the Yarn Brake and break it.

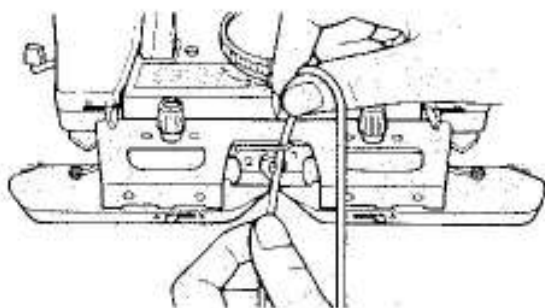

Thread the Nylon Cord into the Yarn Feeder allowing a few inches (8 cm) to hang down below the carriage.

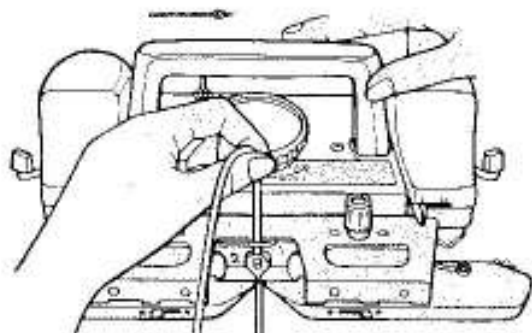

Hold it over your thumb and lightly between your thumb and forefinger, as shown.

Knit 1 row towards the RIGHT allowing the Nylon Cord to slide through your fingers as you knit across.

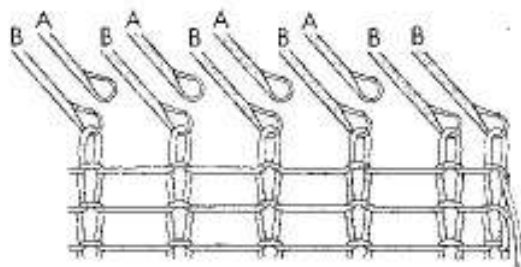

Now you have knitted IN the Nylon Cord to separate the waste yarn from the welt.

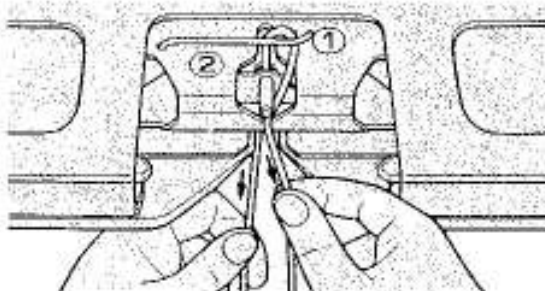

Remove the Nylon Cord from the Yarn Feeder and let it hang down on the side of the knitting.

KNITTING THE 1 BY 1 DOUBLE WELT

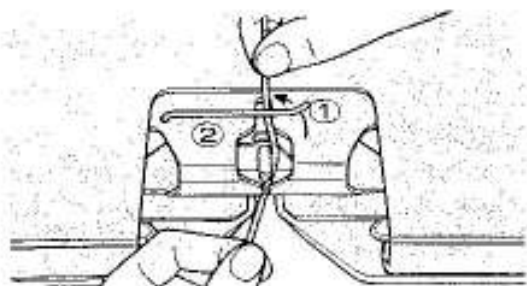

Thread the main yarn through the Yarn Brake and the Yarn Feeder.

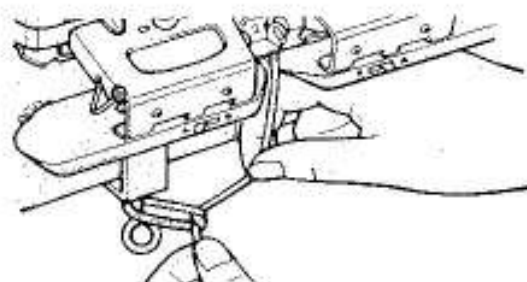

Fasten the end on to the RIGHT side Table Clamp. Check to make sure your yarn is properly threaded up.

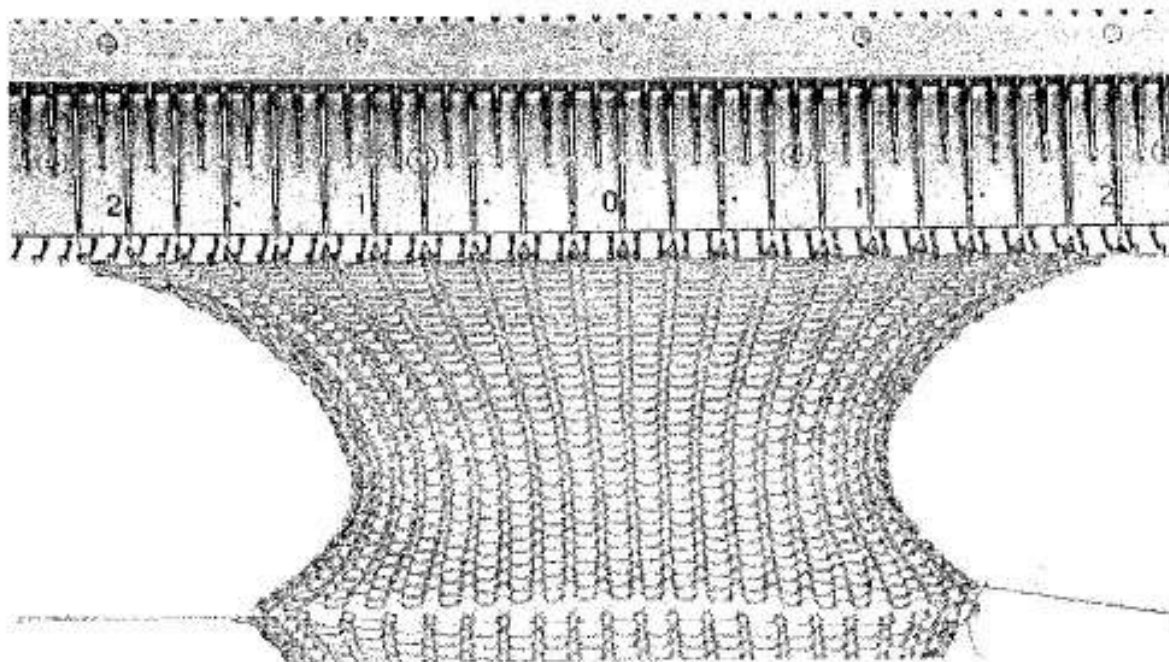

The carriage is at the RIGHT. Turn the Tension Dial to 3. Knit 32 rows.

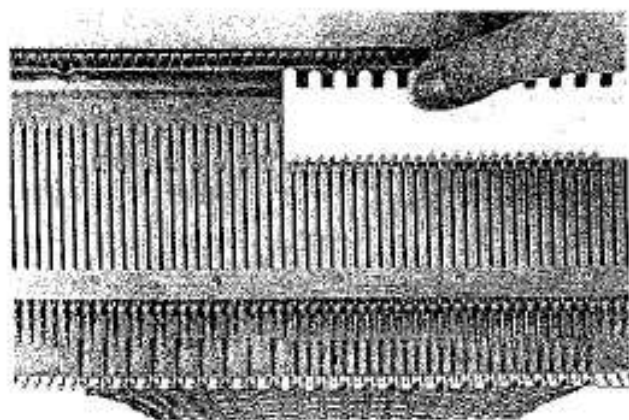

The carriage is at the RIGHT. Using the straight edge of the Needle Pusher, raise from A to B position the remaining 21 needles of the welt (the ones you pushed back to A position earlier).

There are now 43 needles in B position and EVERY SECOND needle has a stitch.

CLOSING THE DOUBLE WELT

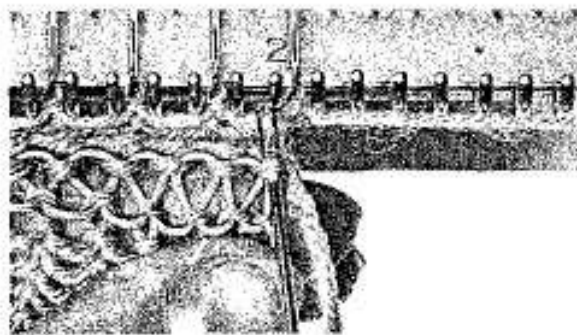

Fold the welt as shown in the photo - the row knitted with the Nylon Cord over your forefinger.

Slip the Transfer Tool inside the FIRST LOOP of the FIRST row knitted AFTER the Nylon Cord at the RIGHT.

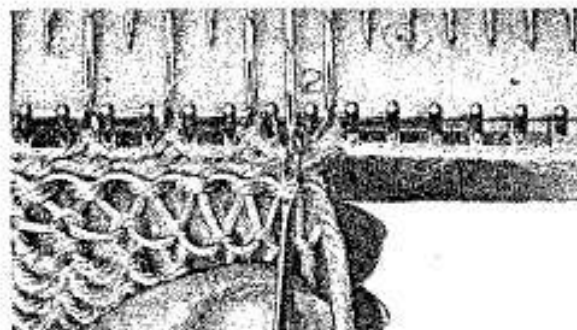

Lift the loop into the FIRST EMPTY needle in B position at the RIGHT.

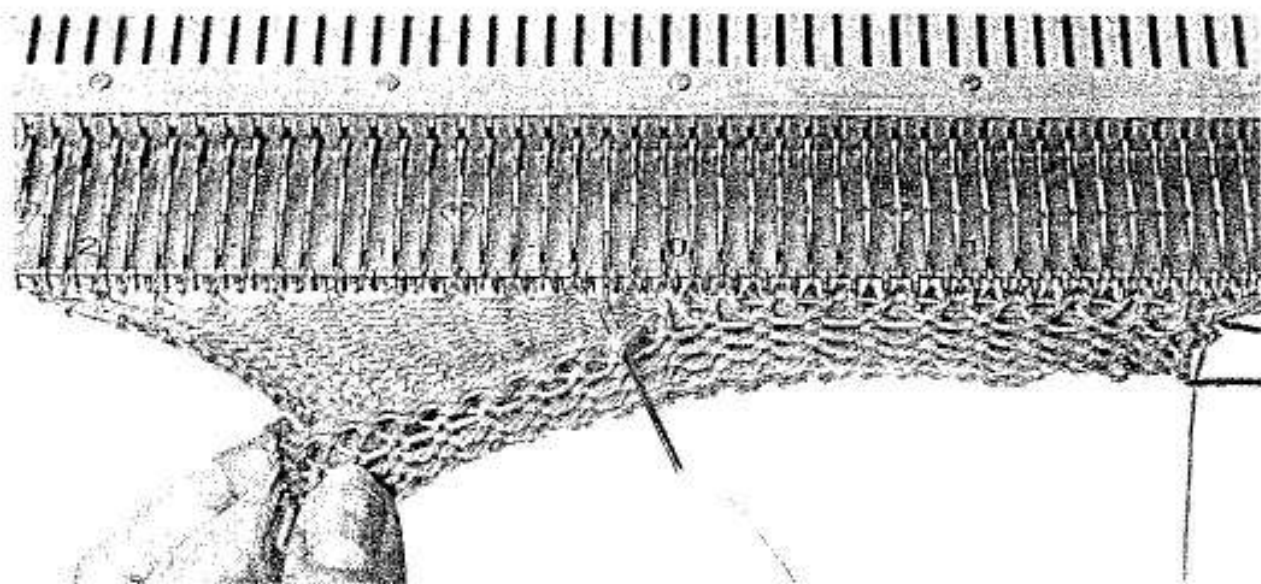

Lift the second loop into the second EMPTY needle in B position. Continue lifting each loop and placing it IN the EMPTY needles until the complete welt has been closed.

With your LEFT hand hold the knitting against the machine. Use the straight edge Needle Pusher to push the needles from B to D position. Set the LEFT side Front Lever to II.

Check the yarn Tension. Set the Tension Dial to 7, knit 1 row. Pull the Nylon Cord out of the knitting.

Knit another 40 rows, cast-off all stitches.

Your first DOUBLE RIBBED WELT is now completed, it only needs to be blocked. For this, follow the instructions on the next pages carefully.

BLOCKING OR STEAMING THE DOUBLE WELT

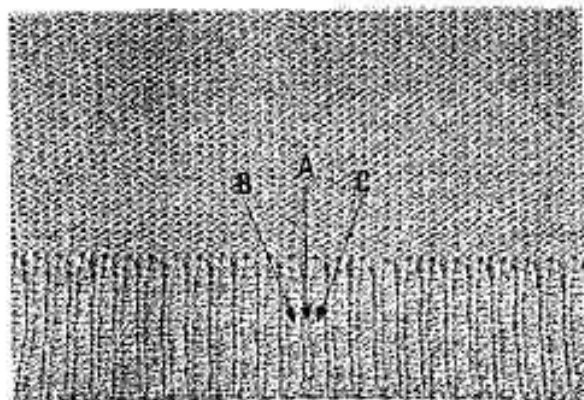

BEFORE STEAMING

Your 1 by 1 double welt will look like this as it comes off the knitting machine. In blocking the yarn A between the ribs will be absorbed INTO the ribs (B - C).

NOTE: Blocking or steaming of the welts is done ONLY AFTER the rest of the garment has been steamed. Ribbed Welts are ALWAYS blocked last.



AFTER STEAMING

This is how the welt will look after blocking, when the instructions are carefully followed.

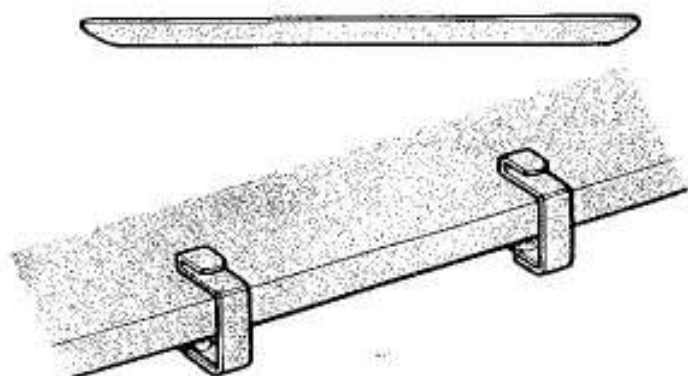

Place BOTH clamps of the Rib Frame on to the front of your ironing board or pressing table,

BLOCKING OR STEAMING THE DOUBLE WELT

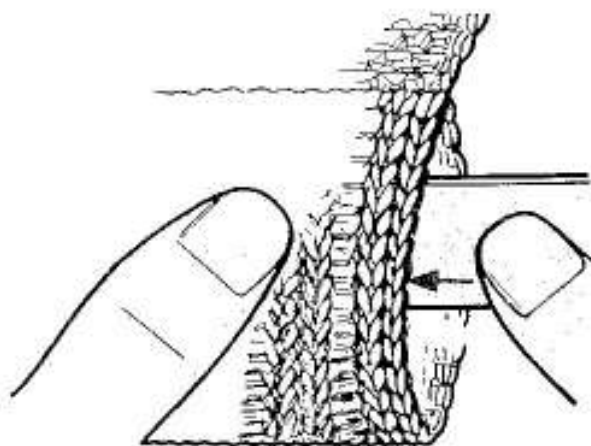

Insert the metal bar through the welt.

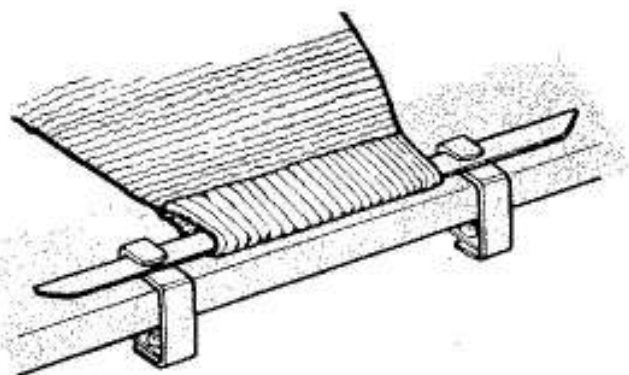

Slide the ends of the bar UNDER the clamps.

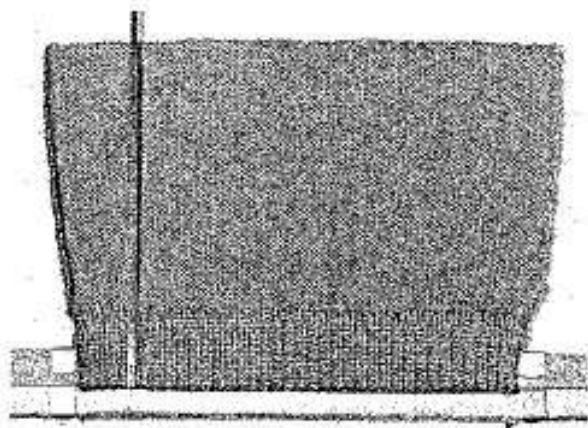

This picture shows you how the welt will look when it is mounted on the Rib Frame. The welt is now only 2 inches (5 cm) wide.

BLOCKING OR STEAMING THE DOUBLE WELT

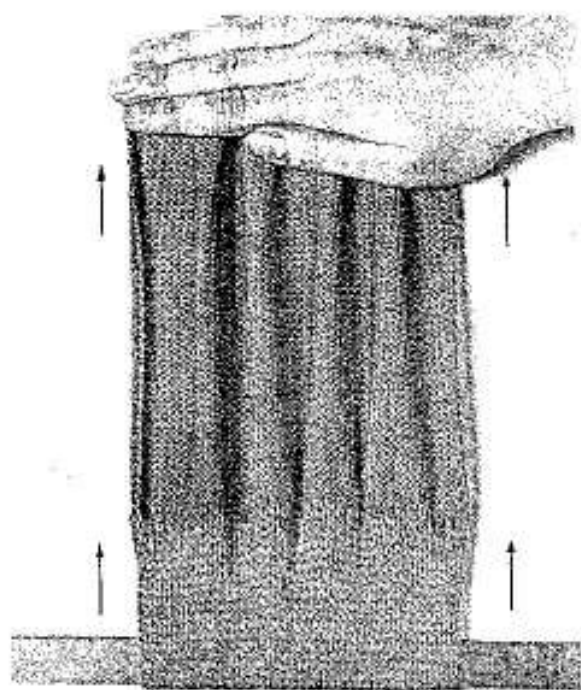

With one hand stretch out your knitted piece as much as possible, pulling away from the Frame, as shown in the picture at LEFT.

At the same time, with the other hand, gather the ribs of the welt together as closely as possible on the Frame.

NOTE: The welt is now about 3 inches long. This means that you must always knit your 1 by 1 welt 1/3 shorter than you want the final length to be.

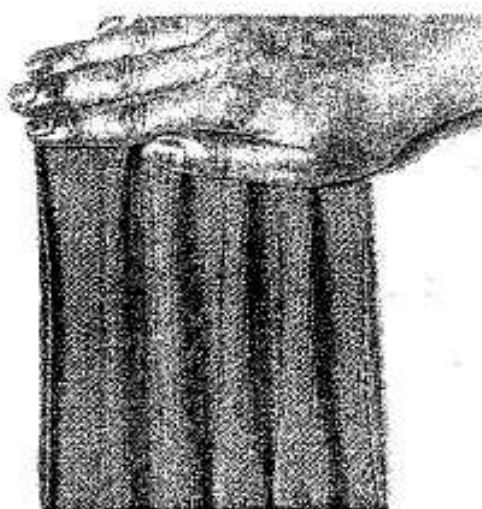

Lay a wet press cloth on top of the welt, still stretching it as much as possible, lower the hot iron on to the wet cloth and let the hot steam penetrate into the knitting. Do NOT PRESS, just slide the iron over the wet cloth until the entire welt has been steamed.

When steaming 4 ply or double knitting yarn you may let the iron rest on the welt for 1 or 2 seconds on each spot.

NOTE: Synthetic yarns. If you are knitting with synthetic yarns exercise the greatest care when steaming your garment, as synthetic yarns do NOT RESPOND to heat in the same manner as natural wools. Always work lightly and quickly.



Remove the cloth and, while the knitting is still hot and damp, continue to stretch it with one hand and then let the knitting cool and dry, while 'gathering' the welt closely with the other hand. If necessary this procedure may be repeated for added elasticity. When the welt is completely dry, remove it from the Rib Frame.

NOTE: Do NOT stretch 2 by 1 and 3 by 1 rib welts as much as the 1 by 1. The linking bars between the stitches must contract and should look like a fine rib after being steamed.

KNITTING A 2 BY 1 WELT



Knitting a 2 by 1 welt means that for every 2 needles in knitting position, ONE needle is in A position.

Bring 33 needles at the RIGHT and 32 needles at the LEFT of center from A to B position.

Starting with the THIRD needle from the RIGHT, push every THIRD needle BACK to A position.

Make an open edge cast-on with waste yarn and knit a few rows, finishing with the carriage at the LEFT.

Knit in the Nylon Cord from LEFT to RIGHT.
Set the Row Counter to 000.
Thread the main yarn through the Yarn Brake and Yarn Feeder.
Set the Tension Dial to 3.

Knit 50 rows, finishing with the carriage at the RIGHT.
Set the Tension Dial to 5.
With the straight edge Needle Pusher, bring every third needle forward from A to B position.

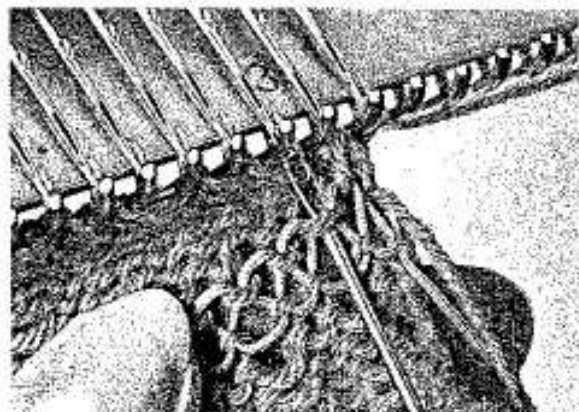

Lift the loops of the FIRST row knitted AFTER the Nylon Cord by hanging the FIRST loop from the RIGHT on to the SECOND needle from the RIGHT (which has a stitch).

Hang the SECOND loop on to the FIRST EMPTY needle from the RIGHT.

Hang the THIRD loop on to the FIFTH needle from RIGHT (which has a stitch).

Hang the FOURTH loop on to the NEXT EMPTY needle.

Continue hanging up the loops. In a group of three needles (2 with stitches and 1 empty) hang 1 loop on the SECOND needle with a stitch and 1 loop on the EMPTY needle.

There will be 2 needles at the LEFT with only 1 stitch on each.

Bring all needles from B to D position while holding the knitting against the machine.
Set LEFT side Front Lever to II and knit 1 row to the LEFT.

Pull out the Nylon Cord, and the waste yarn will fall away from the knitting.
Knit 50 rows and cast-off all stitches.

Steam and block as explained on the previous pages, but don't pull the welt as much lengthwise as the linking bars between the stitches must contract and should look like a fine rib after being steamed.

KNITTING A 3 BY 1 WELT

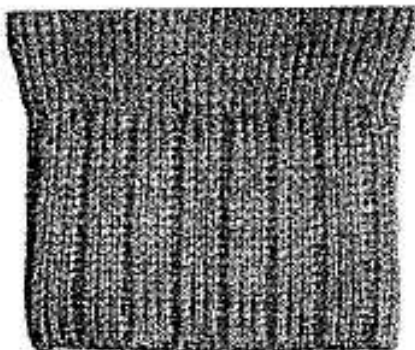

Knitting a 3 by 1 welt means that for every 3 needles in B position, 1 needle is in A position.

Bring 33 needles at the RIGHT and 33 needles at the LEFT of center from A to B position.

Starting with the FOURTH needle from the RIGHT, bring every FOURTH needle back to A position.

Make an open edge cast-on with waste yarn and knit a few rows, finishing with the carriage at the LEFT.

Knit in the Nylon Cord from LEFT to RIGHT.
Set the Row Counter to 000.
Thread main yarn through Yarn Brake and Yarn Feeder.
Set Tension Dial to 3.

Knit 50 rows, finishing with the carriage at the RIGHT.
Set Tension Dia. to 6.
With the straight edge Needle Pusher bring every fourth needle forward from A to B position.

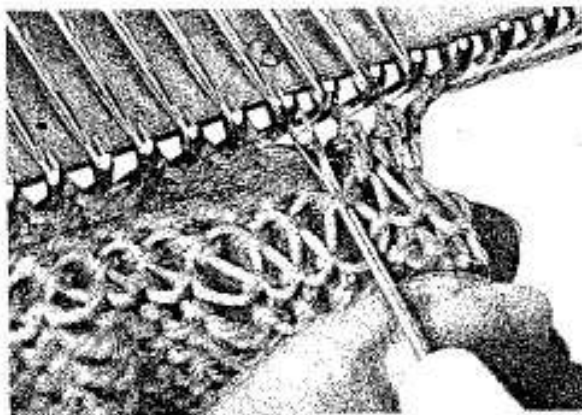

To close the welt, lift the loops of the FIRST row knitted AFTER the Nylon Cord as follows:

The FIRST loop goes on to the SECOND needle with a stitch.

The SECOND loop goes on to the THIRD needle with a stitch.

The THIRD loop goes on to the FIRST EMPTY needle.

Repeat until all loops are lifted, bring the needles from B to D position while holding the knitting against the machine.

Set LEFT side Front Lever to II and knit 1 row to the LEFT.

Pull out the Nylon Cord, and the waste yarn will fall away from the knitting.

Knit 50 rows and cast-off all stitches.

Steam and block as for the 2 by 1 welt.

INCREASING ONE STITCH FULLY FASHIONED



Previously I showed you the simple way to increase 1 stitch at a time. Now try this fully fashioned increasing which you will find on expensive knitwear. It is not difficult to do — it does require a little more time but the improvement in appearance is well worth the extra time.

Another important advantage of fully fashioned shaping is that the garment is much easier to sew up - and you will be absolutely thrilled with the professional results you achieve.

FULLY FASHIONED INCREASING 1 STITCH AT A TIME WITH THE SINGLE TRANSFER TOOL.

NOTE: YOU MAY USE THIS METHOD TO INCREASE AT BOTH EDGES OF THE SAME ROW BUT — ONLY 1 STITCH AT A TIME.

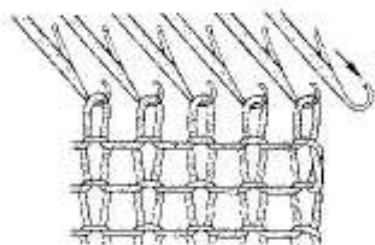

Bring 1 extra needle from A to B position on the side on which you wish to increase.

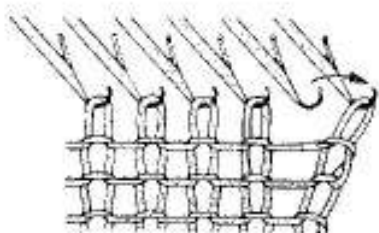

With the single Transfer Tool, transfer the end stitch outwards on to this new empty needle.

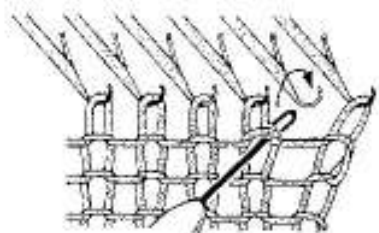

Pick up the bar of the row below the second stitch and place it on to the empty second needle.

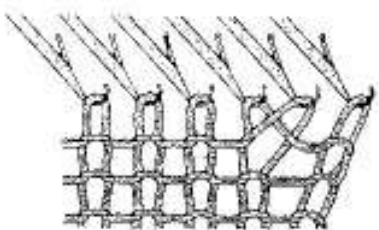

You have now increased one stitch fully fashioned. Knit 2 rows.

For practice, repeat 3 times — knitting 2 rows after each increase.

INCREASING 1 STITCH FULLY FASHIONED WITH THE TRIPLE TRANSFER TOOL

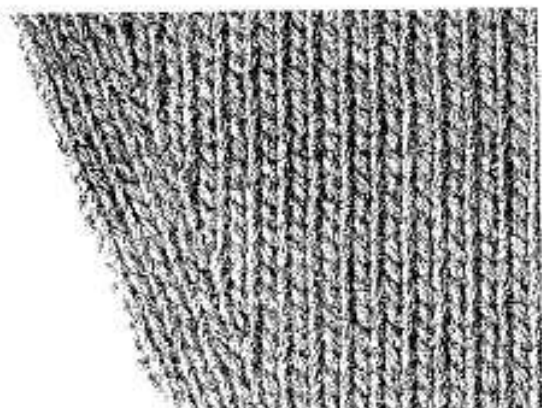

This type of increasing is usually used to make perfect Raglan shaping.

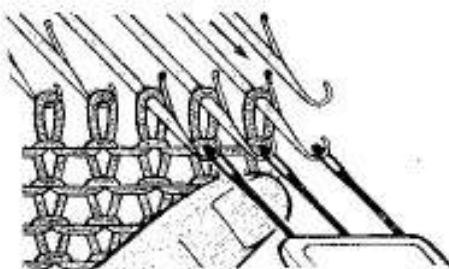

To increase 1 stitch on the RIGHT side, bring 1 more needle at the RIGHT from A to B position. Open the latches of the last 4 needles at the RIGHT.

Hang the Transfer Tool into the hooks of the last 3 needles with stitches. Pull these needles to D position, push them back to A position and then pull them up to B position again. The stitches will slide on to the Transfer Tool.

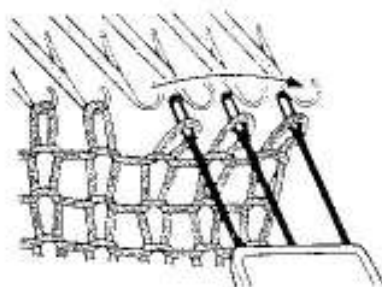

Lift the Transfer Tool with the 3 stitches and transfer the stitches one needle outwards. The 4th needle INSIDE the knitting is EMPTY.

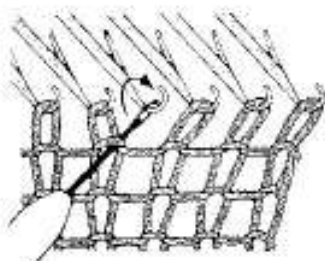

Lift the bar of the 4th stitch of the previous row on to the empty needle.

You have now increased 1 stitch fully fashioned. Knit 4 rows.

Repeat these steps 3 times for practice.

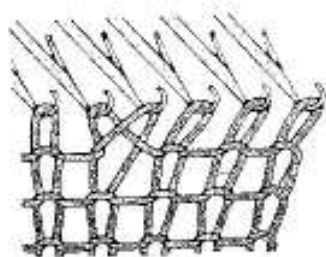

YOU CAN INCREASE THIS WAY ON BOTH SIDES OF THE SAME ROW – BUT ONLY 1 STITCH AT A TIME.

DECREASING 1 STITCH FULLY FASHIONED WITH THE TRIPLE TRANSFER TOOL

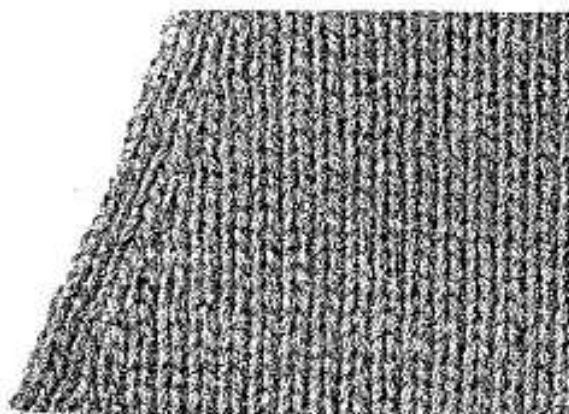

**YOU MAY DECREASE ON BOTH
SIDES OF THE SAME ROW.**

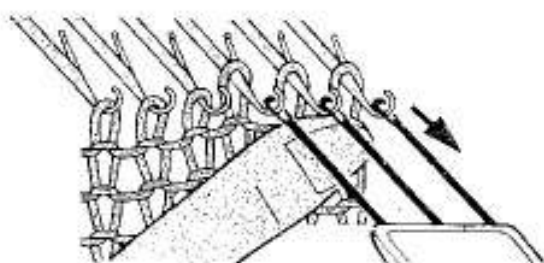

Knit a few rows. Open the latches of the last 4 needles at the RIGHT.

Hang the Transfer Tool into the last 3 needles from the RIGHT. Pull the needles out to D position.

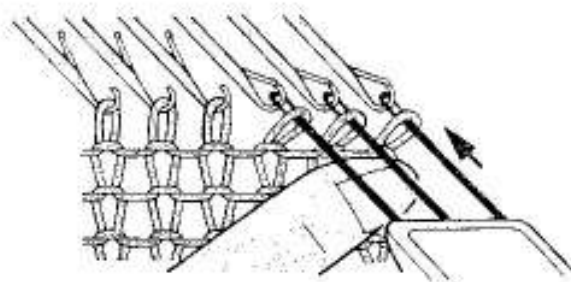

Push them BACK to A position and then pull them slowly up to B position.

Lift the Transfer Tool out of the needles with the stitches on it.

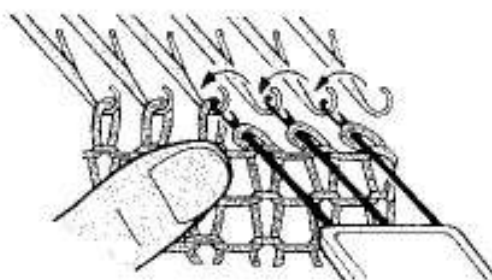

Move the Transfer Tool 1 more needle towards the LEFT. Let the 3 stitches slide into the needle hooks.

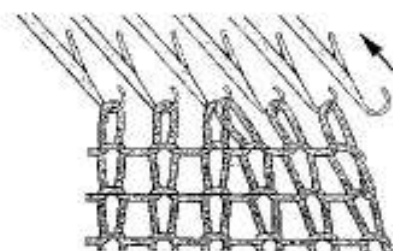

The 4th needle inside the knitting has 2 stitches and the first needle from the RIGHT is empty. Push the empty needle back to A position. Knit 4 rows. Repeat 3 times for practice.

When decreasing for a 'V' neck or Raglan shaping, this method of decreasing is very useful and most attractive.

SHAPING A 'V' NECK IN PLAIN KNITTING

Card release to ● .

Carriage settings are:

1. Tension Dial to 7.
2. Side Levers to FRONT.
3. Cam Lever to center 0 .
4. Front Levers to I.
5. Arm Levers to ▽ .

The carriage is at RIGHT. Set Row Counter to 000.

Cast-on open edge 40 stitches.

Knit 11 rows - carriage at RIGHT.

Row Counter shows 12.

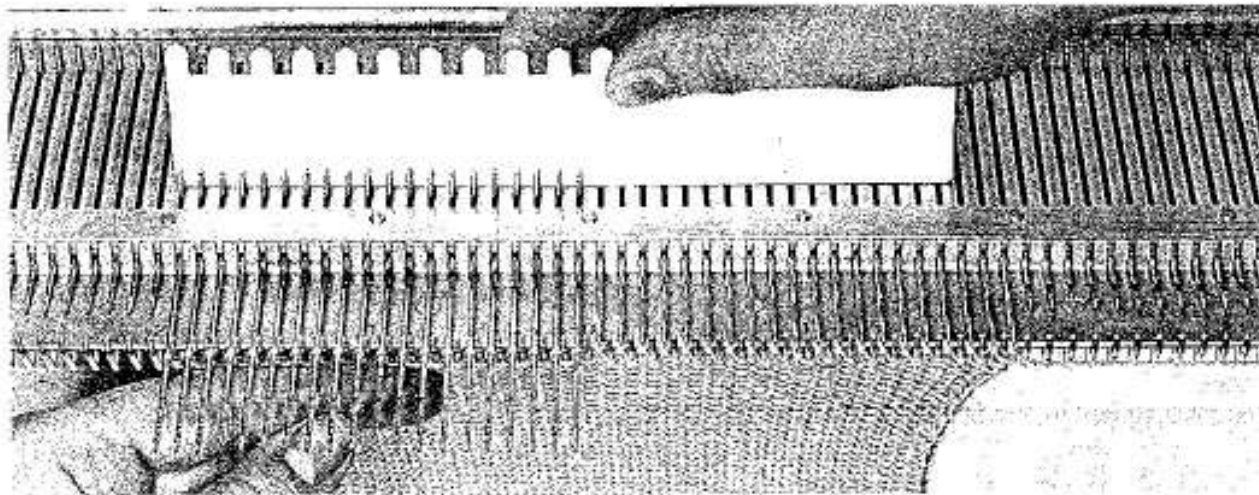
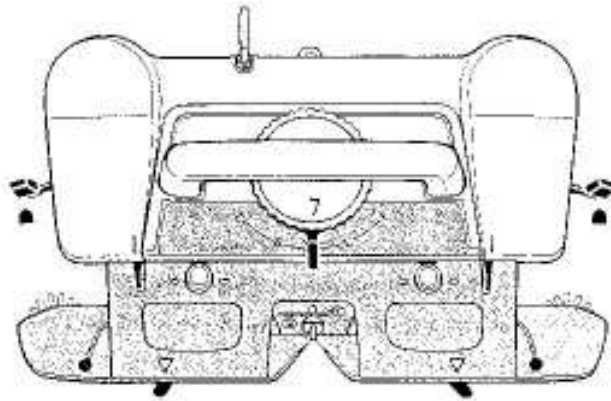

With the straight edge Needle Pusher bring the 20 needles LEFT of center 0 forward to D position, holding the knitting against the machine.

This will ensure that ALL stitches slide BEHIND the needle latches into holding position.

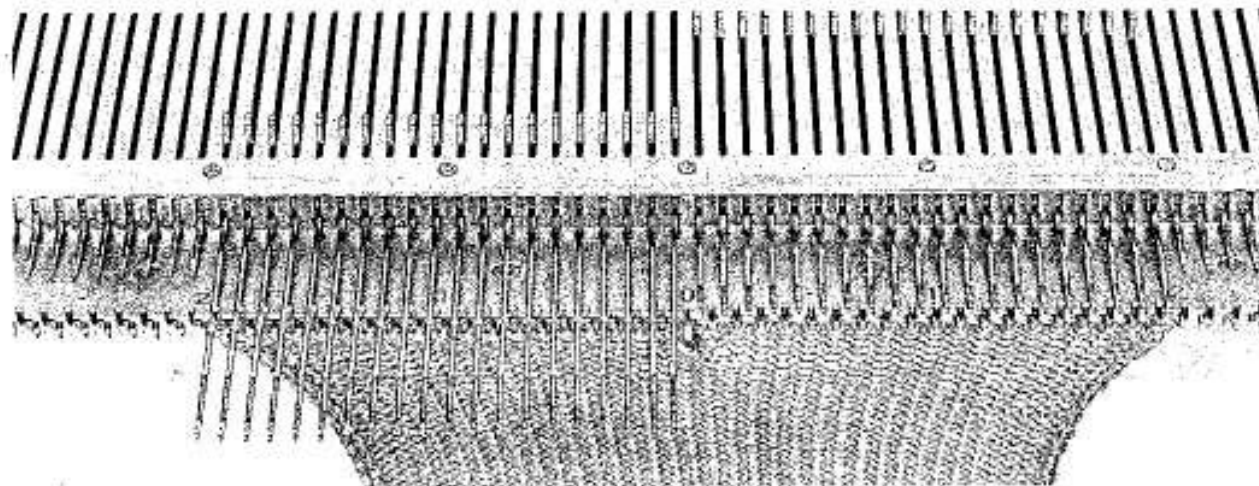

Only the needles in B position will knit; those in D position will NOT knit. You need ONLY move the carriage past the needles in B position.

If the carriage is moved past the needles in D position at the LEFT, the Tension will become loose and this could cause dropped stitches.

Knit 4 rows - you will notice that the carriage has knitted ONLY the stitches on the RIGHT side of center which you left in B position. The needles on the LEFT side have NOT been knitted and in the center of the knitting is the opening for the 'V' neck.

SHAPING A 'V' NECK

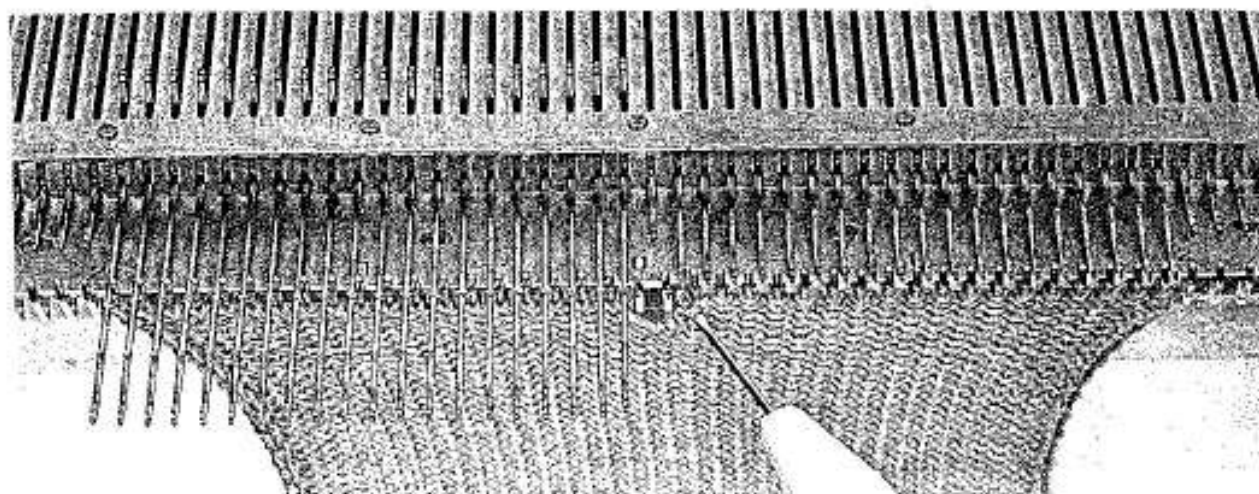

We now start decreasing for the 'V' neck at the neck edge of the RIGHT side section,

Using the Transfer Tool, transfer the last stitch on the LEFT edge of the needles in B position on to its adjacent needle to the RIGHT,

You will then have 1 empty needle on the RIGHT of center - push the empty needle back to A position,

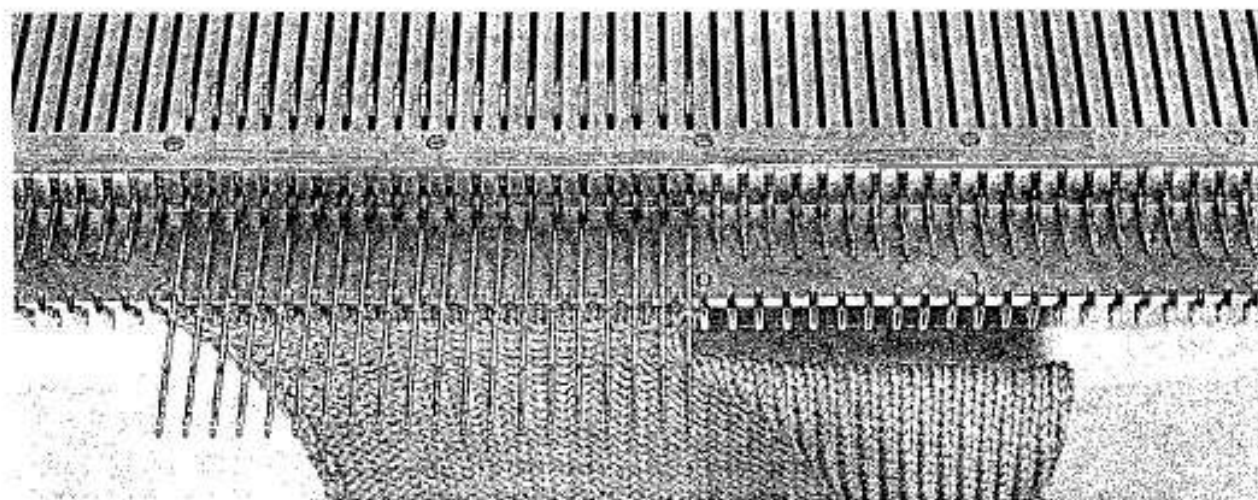

Knit 4 rows. Again transfer 1 stitch in the center of the knitting toward the RIGHT,

Continue knitting 4 rows and transferring 1 stitch towards the RIGHT until you have 10 needles left with stitches at the RIGHT side of center. The Row Counter shows 52. Knit 4 more rows and bind-off the remaining 10 stitches using the method learned on Page 41. The Row Counter shows 56 - set it BACK to 12.

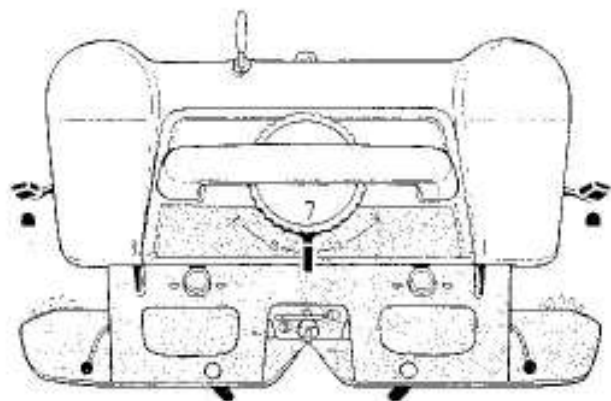

Now we are ready to knit the LEFT section of the 'V' neck.

Push all empty needles back to A position.

The carriage is at the RIGHT.

Check that the Row Counter shows 12.

Front Levers are set to L.

SHAPING A 'V' NECK

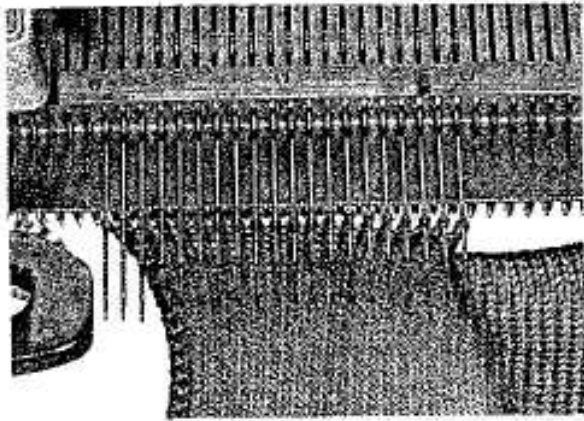

Move the carriage to the LEFT, OVER and PAST the needles in D position.
Re-thread the yarn and fasten the end on to the LEFT side Table Clamp.
Set RIGHT Front Lever to II.
Check the yarn tension.
Knit 4 rows.

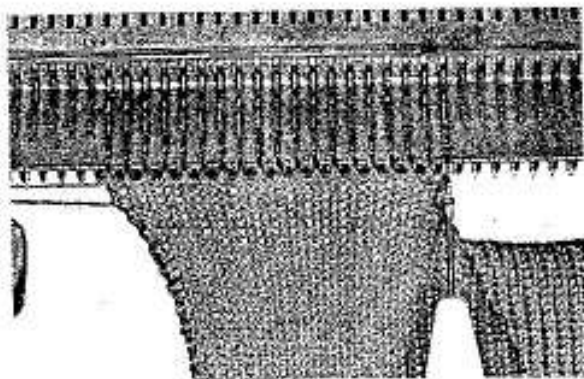

Transfer 1 stitch at the RIGHT edge on to its adjacent needle to the LEFT. Bring the empty needle back to A position.

Knit 4 rows, again transfer 1 stitch at the RIGHT edge on to its adjacent needle to the LEFT.

Repeat knitting 4 rows and transferring 1 stitch at the RIGHT until you have 10 needles remaining in B position. Knit 4 rows and bind-off the last 10 stitches.
The Row Counter shows 56.

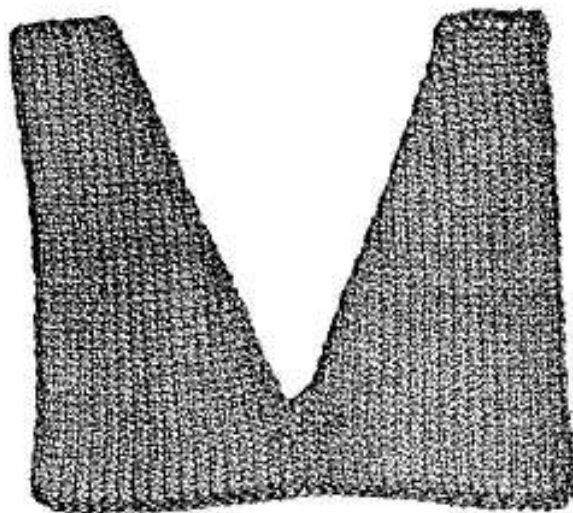

Of course this 'V' neck is a very small size - but when knitting according to pattern instructions, you always get the required size. Each pattern tells you how many rows to knit and how many times to decrease for the 'V' neck.

Here you have learned the simple way of decreasing for the 'V' neck - later you can try the decreasing with the Triple head Transfer Tool - this method gives the fully fashioned shaping effect to your neckline.

SLIT FOR A ZIP FASTENER

If making a slit for a Zip Fastener, you must separate the LEFT and RIGHT sections as for the V neck, BUT - each section is knitted WITHOUT the decreasing at the center.

When doing Stitch Patterns, also have the Front Levers to I when separating the knitting. After finishing the RIGHT section, turn the card BACK to the number noted before. Set card release to ●. Slide carriage to LEFT. Set card, release to ▼. Set Row Counter back. Using Transfer Tool, bring needles from D to B position and continue knitting.

SHAPING A 'V' NECK IN A PATTERNED GARMENT

The method of separating and shaping the V neck when doing Stitch Patterns is the same as for plain knitting. The needles of the LEFT section are pushed to D position.

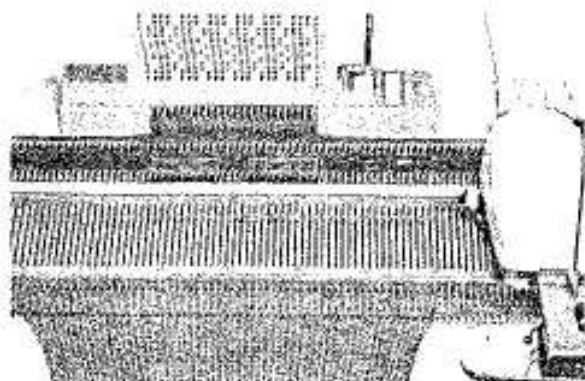

Carriage settings same as for plain knitting (Page 56).
Cast-on open edge 60 needles and knit 6 rows; carriage at LEFT and Row Counter shows 7.
Set card release to ▼.
Take card 4 and insert it - A at RIGHT bottom - into the pattern panel. Turn card UP and secure ends with clamps (Page 94).
Turn card until 60 shows at row indicator.
Knit row 60 toward the RIGHT. Card release to ▼.
Row indicator shows 1 and Row Counter 8.
Set Side Levers BACK and Cam Lever to T.
Knit 30 rows - carriage is at RIGHT.
Row indicator shows 31 and Row Counter 38.

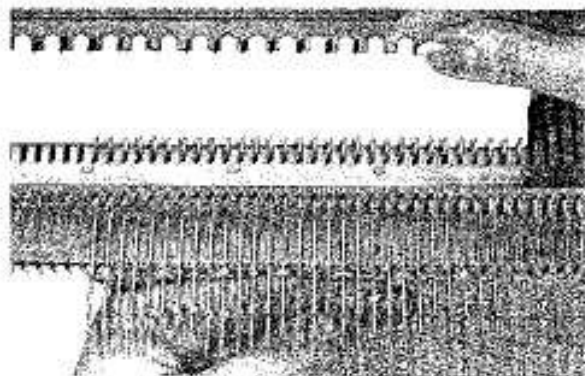

Front Levers to I. Note number of rows showing on row indicator and Row Counter so you can start the second half of neckline with same settings.

Hold the knitting against the machine with your left hand, with the other hand, using the straight edge Needle Pusher, bring the 30 needles at LEFT of center from B to D position.

Here they are in holding position during the partial knitting - as long as the Front Levers are set to I.

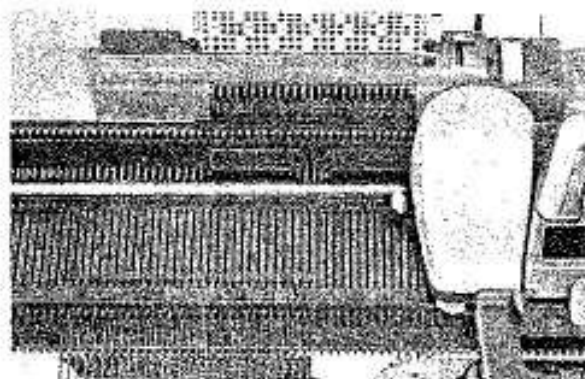

A - Knit 4 rows, at neck edge decrease 1 stitch, towards the RIGHT.

Repeat A until 10 needles remain with stitches. Row indicator shows 51 and Row Counter 118.
NOTE: When moving the carriage to the LEFT, make sure it ALWAYS passes the pattern panel completely BEFORE reversing the movement for the next row.

Knit 4 more rows and cast-off the remaining 10 stitches of the RIGHT section.

Bring the empty needles back to A position. The Row Counter shows 122 and row indicator 55.

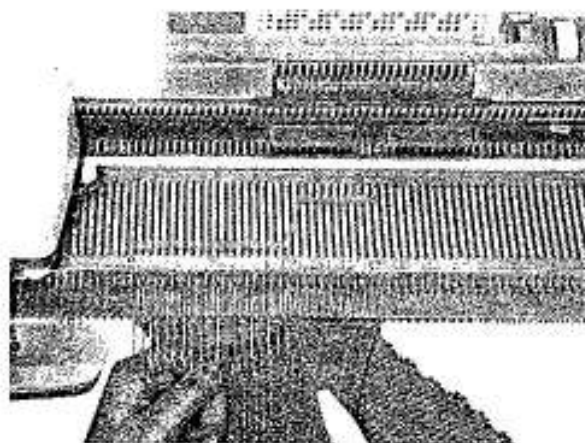

Carriage is at RIGHT. To start the second half of the V neck, you must have row 31 at the row indicator and the carriage at the LEFT.

Turn card until 30 shows at row indicator. Now slide the carriage to the LEFT, past the needles in D position. Row indicator shows 31, and this row of pattern is registered in the RIGHT side pattern memory.

Set Row Counter to 38. Using Transfer Tool, bring the needles from D to B position.

B - Knit 4 rows, at neck edge decrease 1 stitch. Repeat B until 10 needles remain with stitches.

Knit 4 more rows and cast-off the 10 stitches. Row indicator shows 55 and Row Counter 122.

SHAPING A ROUND NECKLINE (METHOD 1)

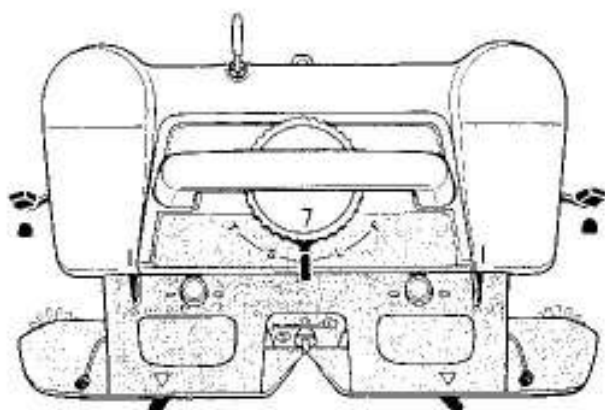

PLAIN KNITTING

Card release to ●.

Carriage settings are:

1. Tension Dial to 7.
2. Side Levers to FRONT.
3. Cam Lever to center, 0.
4. Front Levers to I.
5. Arm Levers to ▽.

Cast-on open edge 40 stitches, knit 29 rows,
Carriage at RIGHT and Row Counter shows 30.

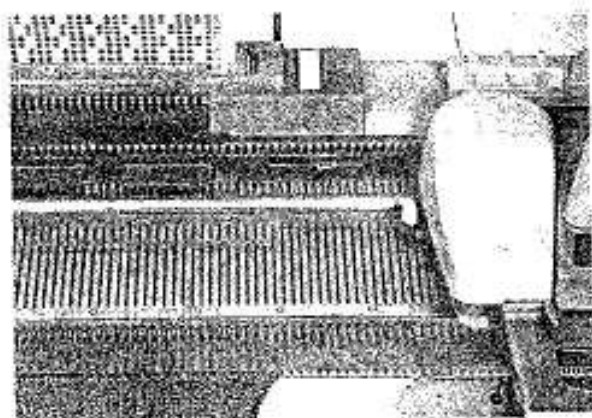

PATTERNING

For cast-on, carriage settings as above.

Knit 6 rows. Carriage at LEFT.

Set card release to ▼ and Side Levers BACK.

Take card 4 and insert it - A at RIGHT

bottom - secure ends of card with clamps.

Turn 60 to row indicator and knit the

pre-setting row to the RIGHT.

Leave card release to ▼.

Row indicator shows 1 and Row Counter 8.

Set Side Levers BACK.

Set Cam Lever to T and knit 22 rows.

Row indicator shows 23 and Row Counter 30.

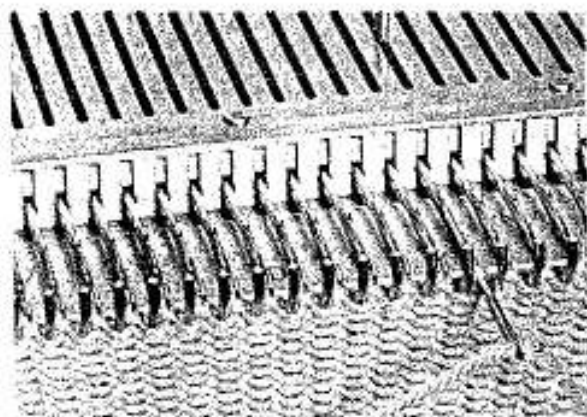

Take a thread of main yarn, about 20 inches
(50 cm) long and cast-off the center 10
stitches as follows:

Push the 6th needle RIGHT of center to D
position. The stitch is BEHIND the latch.

Lay the center of the thread across the EMPTY

and OPEN needle hook of the 6th needle.

Pull this needle back to B position causing the
thread to be knitted through the stitch.

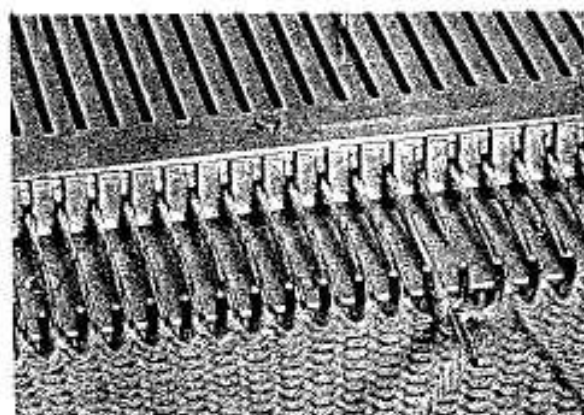

Push the 5th needle RIGHT of center to D
position and lay the thread across the hook,
Pull the needle back to B position.

Transfer the stitch from needle 5 on to needle
4 on the RIGHT of center. Push needle 4 to
D position.

Lay the thread across the hook of needle 4 and
pull the needle back to B position.

SHAPING A ROUND NECKLINE (METHOD 1)

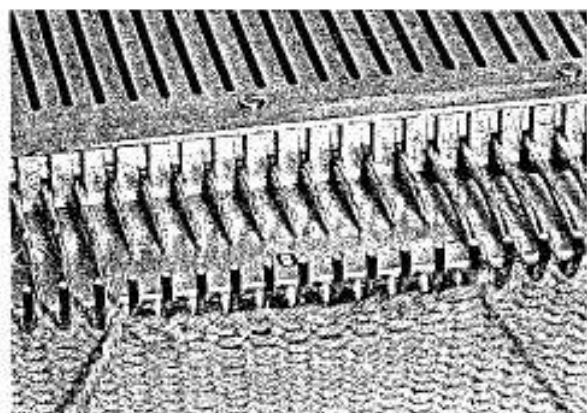

This way, cast or bind-off the 10 center stitches until you have 2 stitches on needle 6 on the LEFT of center. Knit the thread through these 2 stitches but leave the new stitch IN the needle hook. Leave the rest of the thread hanging down from the knitting.

THE CENTER OPENING FOR THE ROUND NECKLINE IS COMPLETED.

The carriage is at the RIGHT and the Row Counter shows 30. Bring the 10 empty needles back to A position.

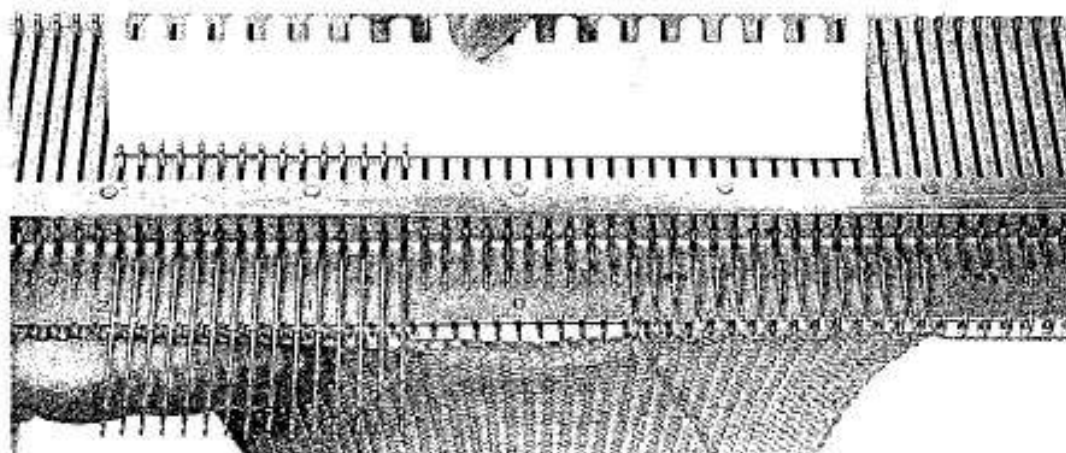

Using the straight edge Needle Pusher bring the 15 needles LEFT of center from B to D position. Again we knit the RIGHT half of the neckline first. Front Levers are set to L. Knit 1 row to the LEFT - past the needles in B position - AND if you are knitting the Stitch Pattern, move the carriage until it has passed the pattern panel completely. Row Counter shows 31. ONLY the needles at RIGHT of center have knitted. To shape neckline - cast-off 2 stitches at LEFT edge of the needles in B position. Bring the empty needles BACK to A position.

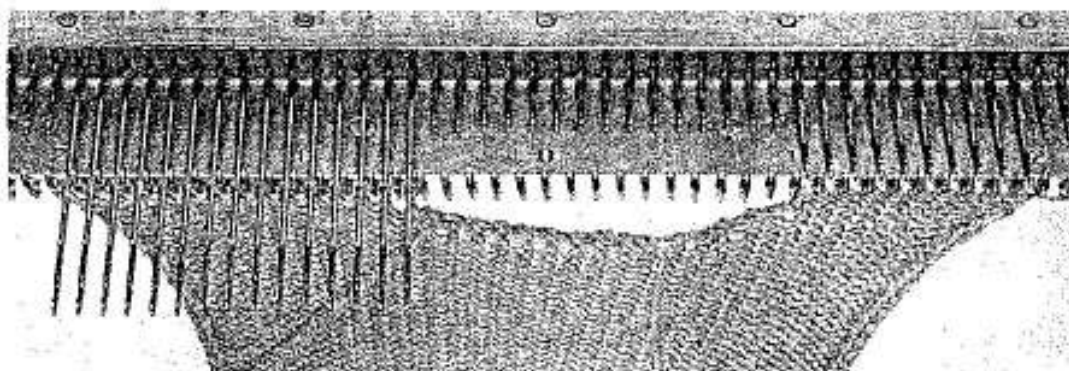

Knit 2 rows, the Row Counter shows 33.
Knit 2 rows, the Row Counter shows 35.
Knit 2 rows, the Row Counter shows 37.
Knit 2 rows, the Row Counter shows 39.
Knit 2 rows, the Row Counter shows 41.
Knit 4 rows, the Row Counter shows 45.
Knit 4 rows, the Row Counter shows 49.

Cast-off 2 stitches for the neckline.
Decrease 1 stitch for the neckline.
Decrease 1 stitch for the neckline.
Decrease 1 stitch for the neckline.
Decrease 1 stitch for the neckline.
Decrease 1 stitch for the neckline.
Decrease 1 stitch for the neckline.

Knit 15 rows - bind-off the remaining 5 stitches. The Row Counter shows 64 and if knitting pattern 4, the row indicator shows 57.

SHAPING A ROUND NECKLINE (METHOD 1)

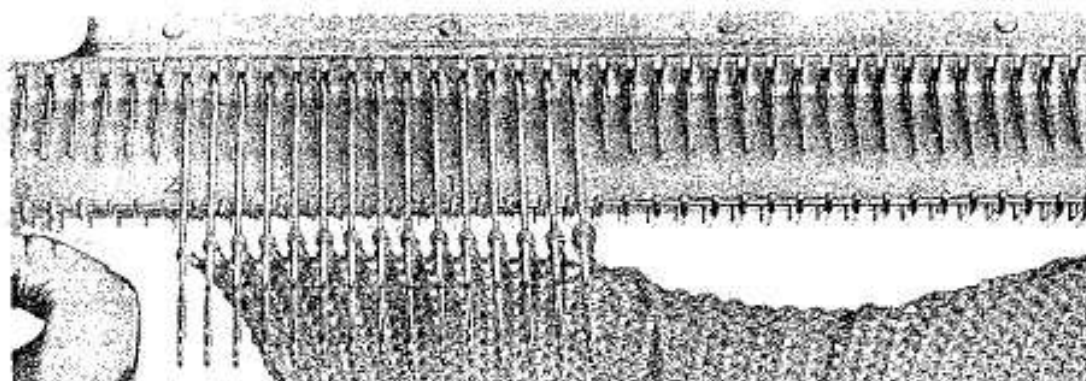

THE SECOND HALF IN PLAIN KNITTING.

Move the carriage towards the LEFT - past ALL needles in D position of the LEFT half, Re-thread the yarn through Feeder 1 and fasten the end on to the LEFT side Table Clamp, Check the yarn tension, Set RIGHT Front Lever to II and Row Counter to 30.

Knit 1 row, at neck edge cast-off 2 stitches,
 Knit 2 rows, at neck edge cast-off 2 stitches,
 Row Counter shows 33,
 Knit 2 rows, at neck edge decrease 1 stitch,
 Row Counter shows 35,
 Knit 2 rows, at neck edge decrease 1 stitch,
 Row Counter shows 37,
 Knit 2 rows, at neck edge decrease 1 stitch,
 Row Counter shows 39,
 Knit 2 rows, at neck edge decrease 1 stitch,
 Row Counter shows 41,
 Knit 4 rows, at neck edge decrease 1 stitch,
 Row Counter shows 45,
 Knit 4 rows, at neck edge decrease 1 stitch,
 Row Counter shows 49,
 Knit 15 rows and cast-off remaining 5 stitches.

THE SECOND HALF IN STITCH PATTERN.

Carriage is at RIGHT, Front Levers to I, Turn 22 to row indicator, Slide carriage to LEFT - PAST the needles in D position, Row indicator shows 23, set Row Counter to 30. Using Transfer Tool, bring needles from D to B position, Re-thread yarn and fasten end to LEFT side Table Clamp, Check yarn tension, Knit 1 row, at neck edge cast-off 2 stitches, Knit 2 rows, at neck edge cast-off 2 stitches, Row Counter shows 33, row indicator 26, Knit 2 rows, at neck edge decrease 1 stitch, Row Counter shows 35, row indicator 28, Knit 2 rows, at neck edge decrease 1 stitch, Row Counter shows 37, row indicator 30, Knit 2 rows, at neck edge decrease 1 stitch, Row Counter shows 39, row indicator 32, Knit 2 rows, at neck edge decrease 1 stitch, Row Counter shows 41, row indicator 34, Knit 4 rows, at neck edge decrease 1 stitch, Row Counter shows 45, row indicator 38, Knit 4 rows, at neck edge decrease 1 stitch, Row Counter shows 49, row indicator 42, Knit 15 more rows, cast-off the 5 stitches.



This round neckline does not have the open stitches to be hanged on to the needles from knitting the neckband. (Method 2).

SHAPING A ROUND NECKLINE (METHOD 2)

This method of shaping a neckline is suitable when the sweater or dress does not have a zipper or back opening and should be pulled over the head.

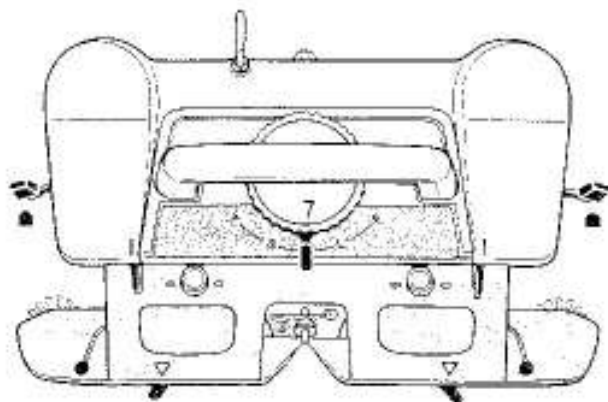

PLAIN KNITTING

Card release set to ●.

Carriage settings are:

1. Tension Dial to 7.
2. Side Levers to FRONT.
3. Cam Lever to center 0.
4. Front Levers to I.
5. Arm Levers to ▽.

Cast-on open edge 60 needles and knit 29 rows. Carriage at RIGHT and Row Counter shows 30.

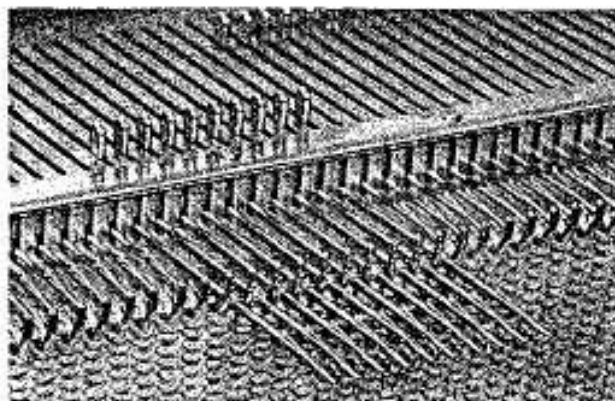

PATTERNING

Carriage settings as above, cast-on open edge 60 needles and knit 6 rows, carriage at LEFT.

Set Card release to ▼ and Side Levers BACK. Take card 4 and insert it - A at right bottom - into the pattern panel. Secure ends of card. Turn card so that 60 is at row indicator. Card release to ▼ - knit to the RIGHT.

Row Indicator shows 1 and Row Counter 8.

Set Cam Lever to T and knit 22 rows.

Row indicator 23 and Row Counter 30.

BRING 10 CENTER NEEDLES TO D POSITION.

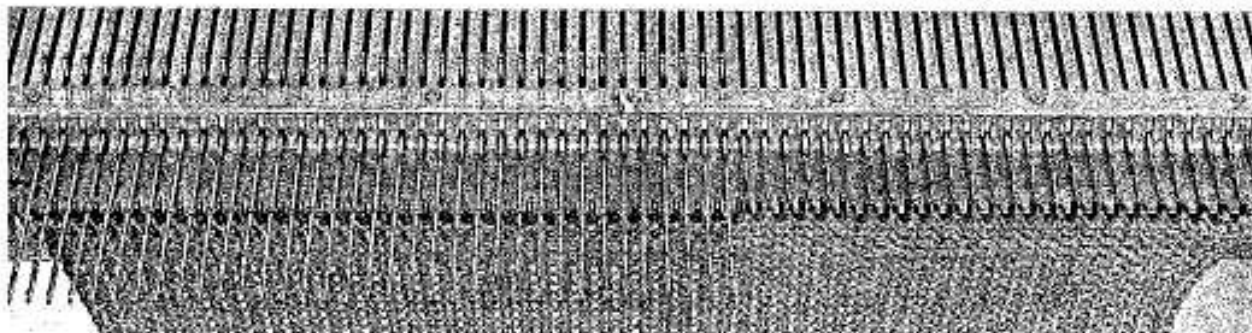

Bring to D position: ALL other needles at LEFT of center.

The RIGHT section of the neckline is knitted first. Make sure BOTH Front Levers are set to I.

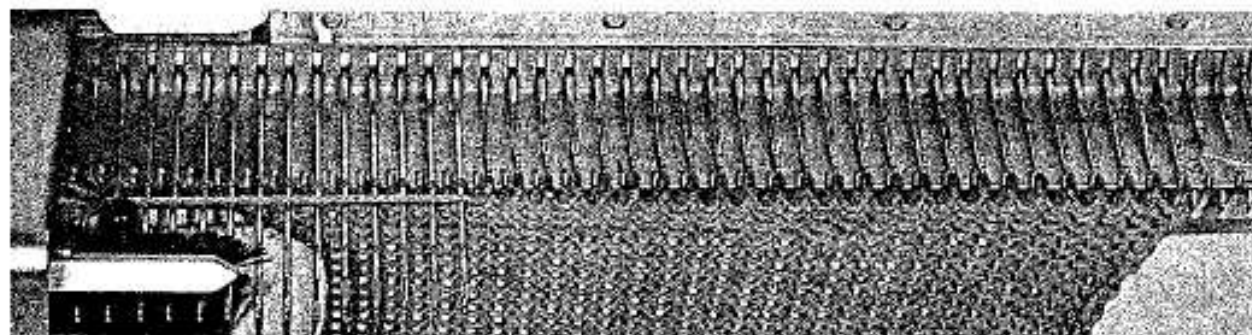

Knit to the LEFT, PAST the pattern panel. When doing plain knitting, only past the needles in B position.

SHAPING A ROUND NECKLINE (METHOD 2)

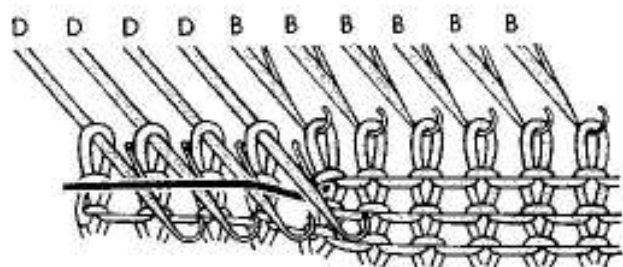

PLAIN KNITTING AND PATTERNING

Bring the yarn UNDER the INSIDE needle in D position as shown in diagram.

When doing Fair Isle or Lace patterns, bring BOTH threads under the needle in D position.

Knit to the RIGHT.

Row indicator shows 25 and Row Counter 32.

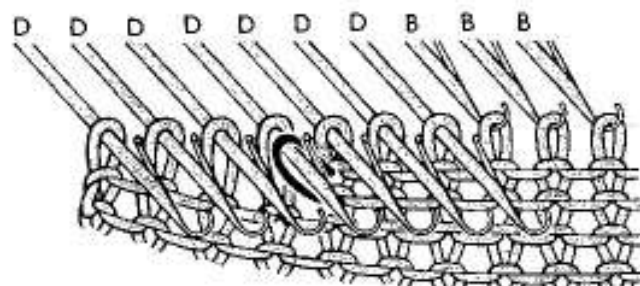

At the LEFT of the needle in B position, bring 3 more needles to D position.

Knit to the LEFT, past the pattern panel, and when doing plain knitting, past the needles in B position.

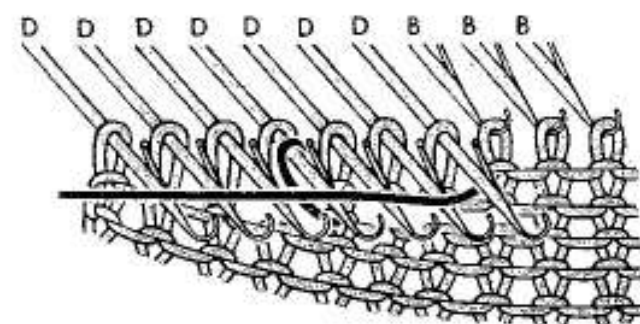

Bring the yarn UNDER the INSIDE needle in D position at LEFT as shown in diagram. Knit to the RIGHT.

Row indicator shows 27 and Row Counter 34.

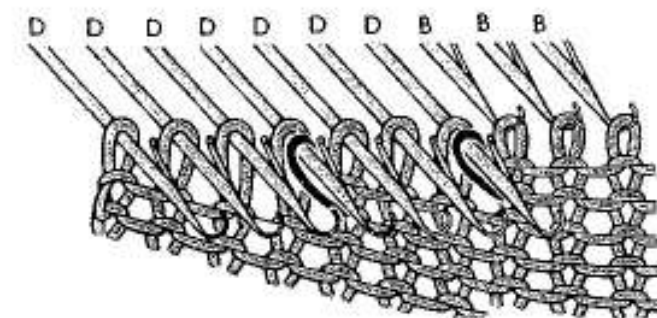

* At the LEFT of the needles in B position, bring 2 more needles to D position. Knit to the LEFT. Bring the yarn under the inside needle in D position and knit to the RIGHT.*

Repeat from * to * 3 more times.

Row indicator shows 35 and Row Counter 42.

**At LEFT of needles in B position, bring 1 more needle to D position. Knit to the LEFT, past the pattern panel or the needles in B position.

Bring the yarn under the inside needle in D position and knit to the RIGHT.**

Repeat from ** to ** 3 more times.

Row indicator shows 43 and Row Counter 50.

SHAPING A ROUND NECKLINE (METHOD 2)

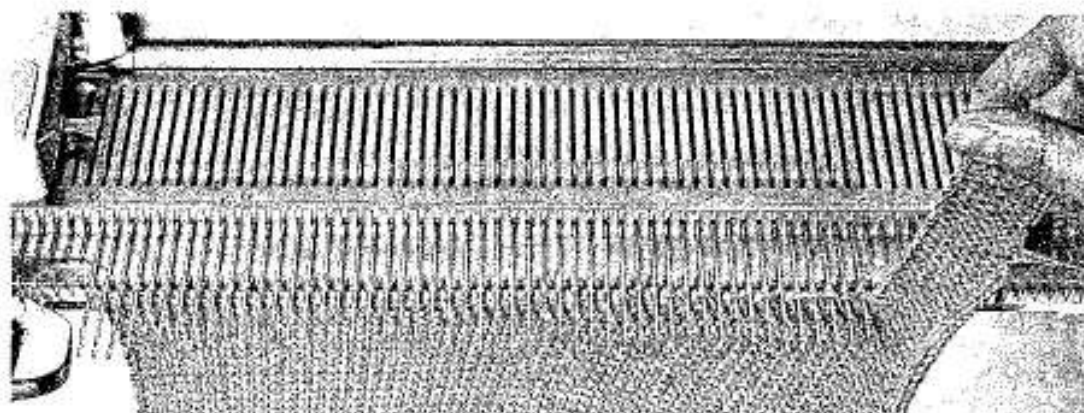

PLAIN KNITTING

Knit 10 more rows. Row Counter shows 60. Carriage at RIGHT. Remove main yarn from Feeder and thread waste yarn. Knit several rows; finish with carriage at RIGHT.

Remove waste yarn from Feeder and move carriage to the LEFT – PAST – the needles in D position. The last 10 stitches at the RIGHT are removed from the needles. Bring the empty needles back to A position.

PATTERNING

Knit 10 more rows. Carriage at RIGHT. Row indicator shows 53 and Row Counter 60. Remove main yarn from Feeder and thread waste yarn. Set card release to ●, Cam Lever to 0.

WITHOUT pattern, knit several rows; finish with the carriage at the RIGHT. Remove the waste yarn. Card release to ▼.

Turn card so that 22 shows at row indicator. Move carriage to LEFT – OVER and PAST the needles in D position. Row indicator shows 23 - set Row Counter to 30. The last 10 stitches at the RIGHT are removed from the needles. Bring the empty needles back to A position.

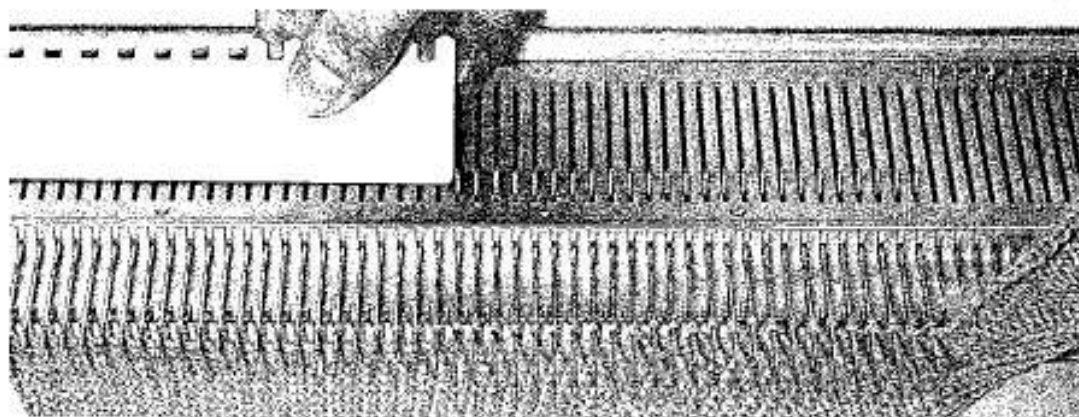

PLAIN – Carriage at LEFT. Thread main yarn and fasten the end to the LEFT side Table Clamp. Set Row Counter to 30. Using straight edge Needle Pusher and starting at LEFT, bring 25 of the 30 needles LEFT of center from D position back to C position. Knit 1 row to RIGHT past the Row Counter. The needles in C position have been knitted back to B position. Row Counter shows 31.

PATTERNING – Carriage is at LEFT. Front Levers to 1 and card release to ▼. Thread main yarn and fasten the end onto the LEFT side Table Clamp. Using Transfer Tool and starting at LEFT – bring 25 needles back from D to B position. Set Cam Lever to T and knit 1 row to the RIGHT – PAST the pattern panel and the Row Counter.

SHAPING A ROUND NECKLINE (METHOD 2)

At RIGHT of the needles in B position, bring the yarn under the INSIDE needle in D position, Knit to the LEFT, Row indicator shows 25 and Row Counter 32.

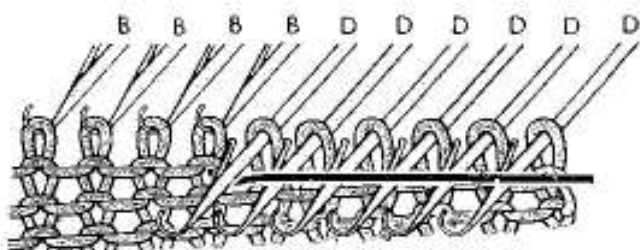

At LEFT of needles in D position, bring 3 needles to D position, Knit to RIGHT - FAST pattern canal and Row Counter, Bring the yarn under the inside needle in D position, Knit to the LEFT, Row indicator shows 27 and Row Counter 34.

* At LEFT of needles in D position, bring 2 needles to D position, Knit to RIGHT - past Row Counter, Bring yarn under inside needle in D position, Knit to LEFT,*
Repeat from * to * 3 more times, Row indicator shows 35 and Row Counter 42.

** At LEFT of needles in D position, bring 1 needle to D position, Knit to RIGHT - past Row Counter, Bring yarn under inside needle in D position, Knit to LEFT,**
Repeat from ** to ** 3 more times, Row indicator shows 43 and Row Counter 50,
Carriage at LEFT.

Knit 10 more rows, If patterning, set card release to ● and Cam Lever to center 0. Remove main yarn and thread waste yarn, Knit several rows of waste yarn, finish with the carriage at LEFT, Remove waste yarn and move the carriage to the RIGHT - over and past the needles in D position, The 10 stitches at LEFT are removed from the needles, bring the empty needles back to A position, At RIGHT, thread main yarn and set LEFT Front Lever to II, Knit 1 row to the LEFT and remove the main yarn, Thread waste yarn and knit several rows, Remove waste yarn from Feeder and move the carriage once more across the knitting, The stitches are removed from the needles.

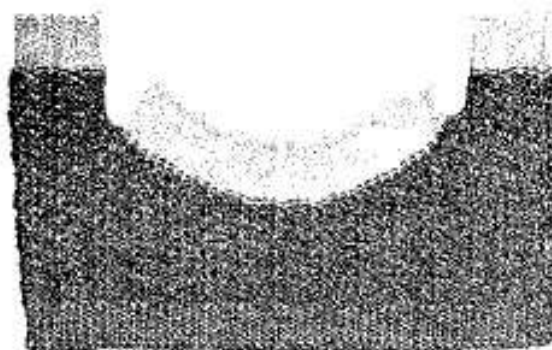
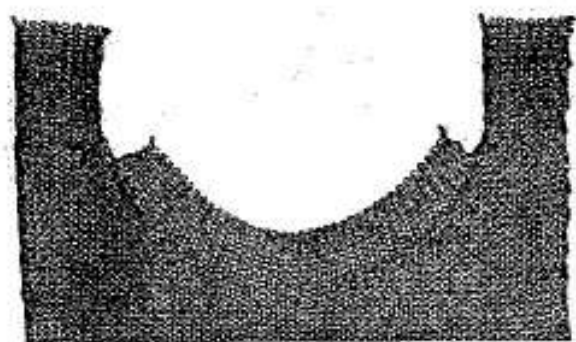

These are the necklines knitted to the above instructions, After steaming Front and Back, close one shoulder seam and unravel the waste yarn from the neckline until the last row, Hold shoulder seam to center of machine.

Where you knitted the rows straight up (mostly of Front) you will have no stitches, so just take a loop of every second row and hang it into a needle.

Then, unravel stitch by stitch the waste yarn and hang the stitches of the neckline into the needles.

POCKETS IN PLAIN KNITTING

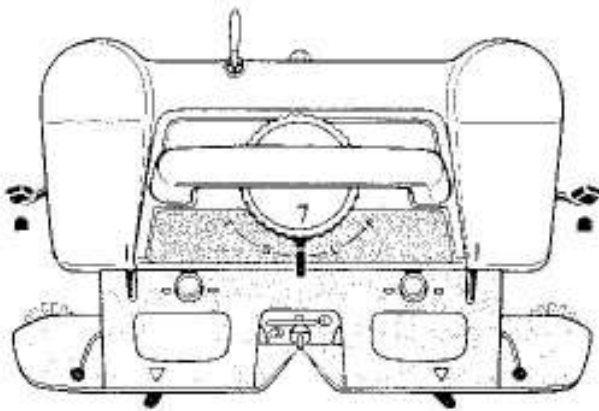

Card release set to ●,
 Carriage settings are:
 Tension Dial to 7 - Side Levers to FRONT,
 Cam Lever center 0 - Front Levers to 1,
 Arm Levers to ▽,
 Cast-on open edge 60 needles and knit 21
 rows, finishing with carriage at RIGHT.
 Row Counter shows 22.

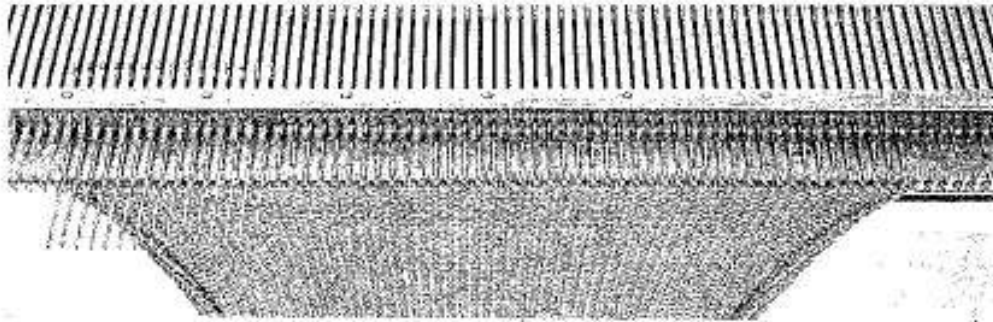

Hold knitting against Sinker Gate and with straight edge Needle Pusher bring 15 needles at LEFT of center from B to D position.

Set Row Counter tripper OUT of action by lifting it up and turning it sideways.
 Knit 1 row to the LEFT. The 15 needles at the LEFT in D position have not been knitted and the yarn lies on top of them.

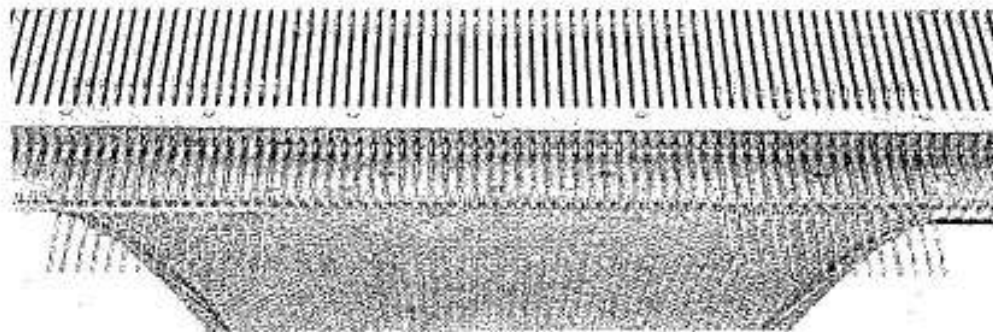

Bring 15 needles at the RIGHT edge from B to D position. This will leave 30 needles in the center in B position, which will be the width of the pocket.

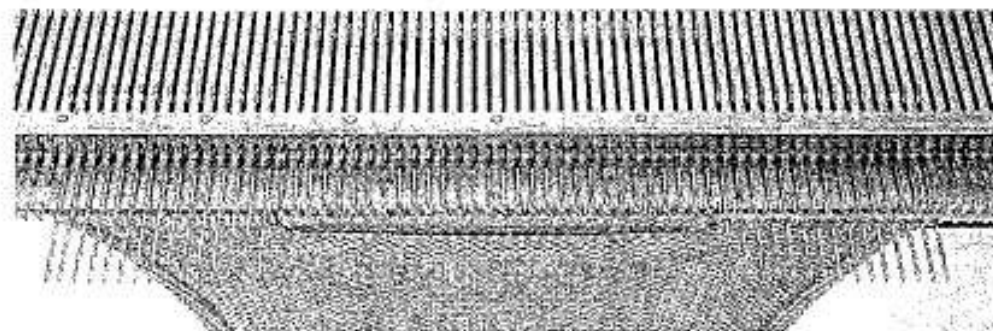

Knit 81 rows, finishing with the carriage at the RIGHT.

NOTE: You will have to count the rows as the Row Counter is out of action. If you wish to count the rows using the Row Counter, then leave the Row Counter tripper in action and turn back the Row Counter when the pocket is finished. But note and return to the row at which you started the pocket.

POCKETS IN PLAIN KNITTING

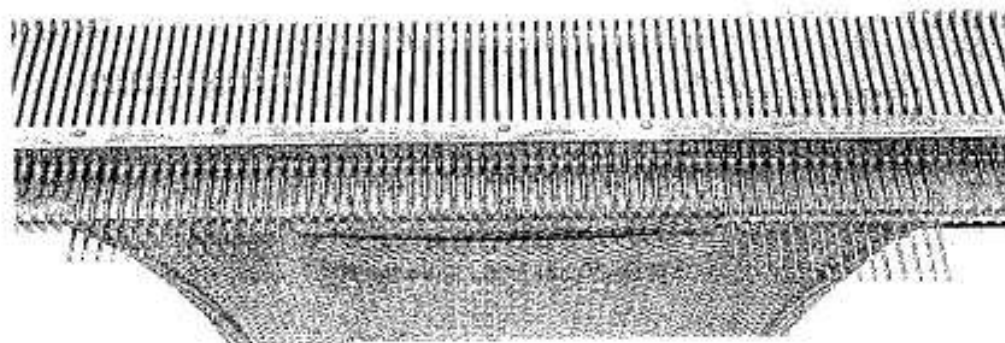

The carriage is at the RIGHT. Using the straight edge Needle Pusher, push the 15 needles on the LEFT edge carefully back to C position. Set the Row Counter tripper back into action if necessary and knit 1 row towards the LEFT. The Row Counter shows 23.

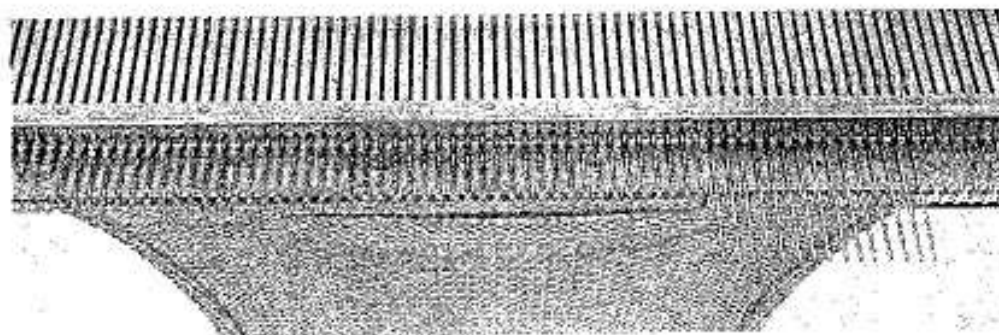

The carriage is at the LEFT and the 15 needles on the LEFT side have been knitted back to B position. Now push the 15 needles on the RIGHT edge back to C position.

Knit 1 row towards the RIGHT. All needles are now knitted back to B position. The Row Counter shows 24.

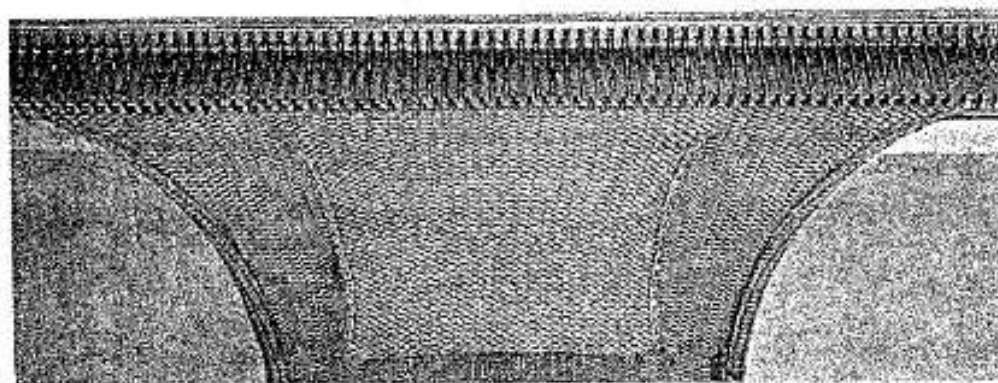

If you now look at your pocket, you will see that only the side edges will need to be sewn up to close the pocket completely.

NOTE: To make a wider pocket, leave more needles in B position. To make it narrower, leave fewer needles in B position. You may also vary the depth of the pocket by changing the number of rows which you knit.

KNITTING A POCKET IN A PATTERNED GARMENT

Card release to ●. Carriage settings are same as on Page 67.

Cast-on open edge 60 needles and knit 6 rows, carriage is at LEFT. Set card release to ▼.
Take card 4 and insert it - A at RIGHT bottom - into the pattern panel. Secure card ends.
Turn card until 60 shows at row indicator, leave card release to ▼, knit 1 row to the RIGHT.
Row indicator shows 1 and Row Counter 8. Set Side Levers BACK.
Set Cam Lever to T and knit 24 rows.
Row indicator shows 25 and Row Counter 32.

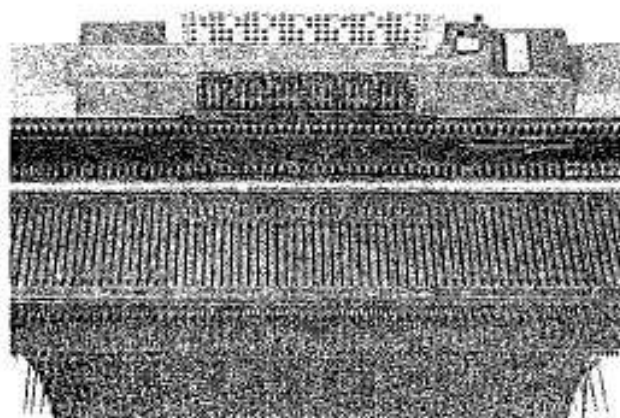

With the straight edge Needle Pusher bring 15 needles at LEFT edge from B to D position.

Bring 15 needles at RIGHT edge from B to D position.

Break the yarn below the carriage and fasten the end on to the Table Clamp.
Set Card release to ● and Cam Lever to center 0.
BOTH Front Levers are set to I.
Set Row Counter tripper out of action by lifting it up and turning it sideways.

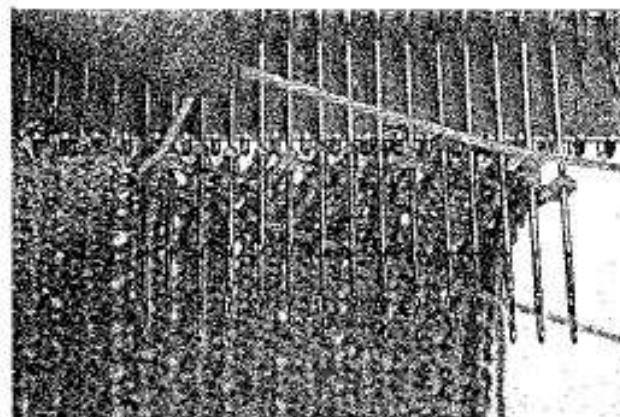

Take the yarn to the LEFT of the needles in D position at the RIGHT.

SLOWLY move the carriage to the LEFT, the needles in B position will knit.

NOTE: When doing Fair Isle or Weaving patterns, the pocket is knitted in color 1 (Feeder 1) ONLY. When doing Fair Isle remove the yarn from Feeder 2 and set Cam Lever to center 0.

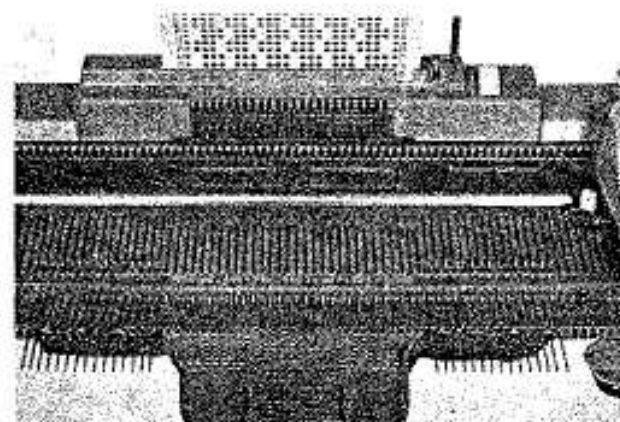

Knit 6 more rows. Hang the claws on to the edge of the pocket and knit 74 more rows - ALWAYS - bring the claws up when they hang down from the bottom of the pocket.

After these 80 rows, break the yarn below the carriage and fasten the new end on to the RIGHT side Table Clamp. The loose threads hang down in front of knitting.

Using Transfer Tool, bring needles from D to B position. Set Row Counter tripper into action. Set card release to ▼.
Cam Lever to T and continue knitting the pattern.

DARTS – IN PLAIN KNITTING AND PATTERNS

PLAIN

Card release set to ● .

Carriage settings are:

1. Tension Dial to 7.
2. Side Levers to FRONT.
3. Cam Lever to center 0.
4. Front Levers to ↓ .
5. Arm Levers to ▼ .

Cast-on open edge 60 needles and knit 24 rows.

The carriage is at the RIGHT and the Row Counter shows 30.

PATTERNING

Settings as for plain knitting.

Cast-on open edge 60 needles and knit 6 rows.

Carriage at LEFT. Set card release to ▼ .

Take card 3 and insert it - A at RIGHT bottom - into the pattern panel. Secure card ends.

Turn card until 56 shows at Row indicator.

Knit pre-setting row 56 to the RIGHT.

Row indicator shows 1 and Row Counter 8.

Set Side Levers BACK, leave card release to ▼ .

Set Cam Lever to T and knit 22 rows.

Row indicator shows 23 and Row Counter 30.

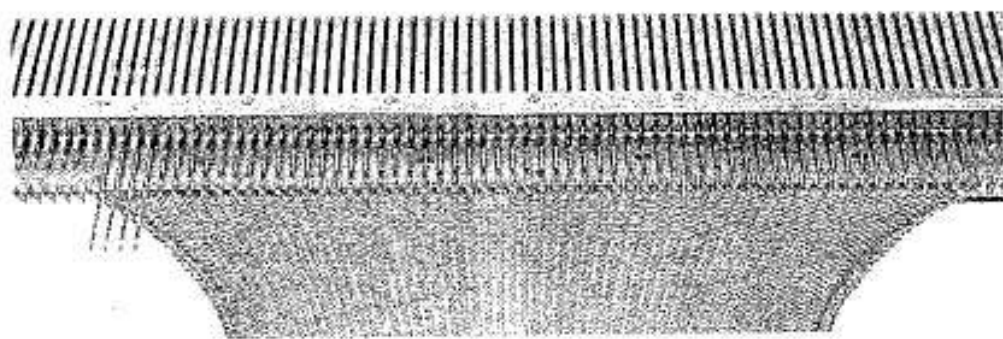

Carriage is at RIGHT.

Holding the knitting against the machine, push 4 needles at LEFT edge of knitting from B to D position. Make sure BOTH Front Levers are set to I. Knit 1 row to the LEFT, PAST the pattern panel when knitting a Stitch pattern and past the needles in B position for plain knitting.

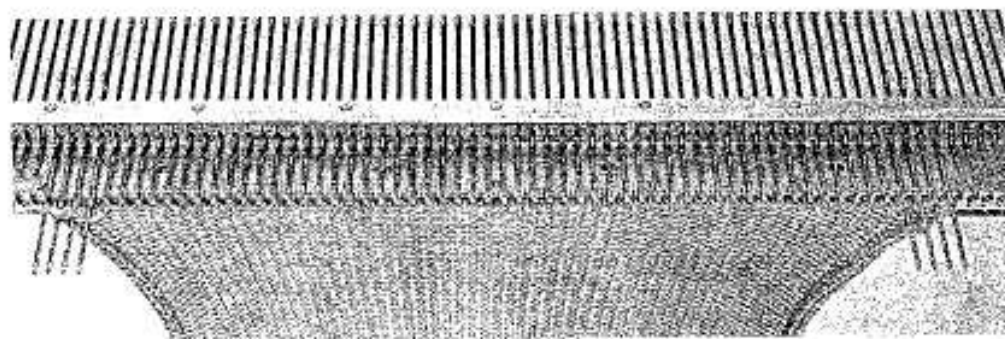

The 4 needles in D position at the LEFT have NOT been knitted and the yarn lies on top of these needles. Take the yarn UNDER the INSIDE needle in D position and lay it over the other 3 needles in D position. Now push 4 needles at the RIGHT to D position. Knit 1 row to the RIGHT.

NOTE: When knitting Fair Isle patterns, bring BOTH threads UNDER the INSIDE needle.

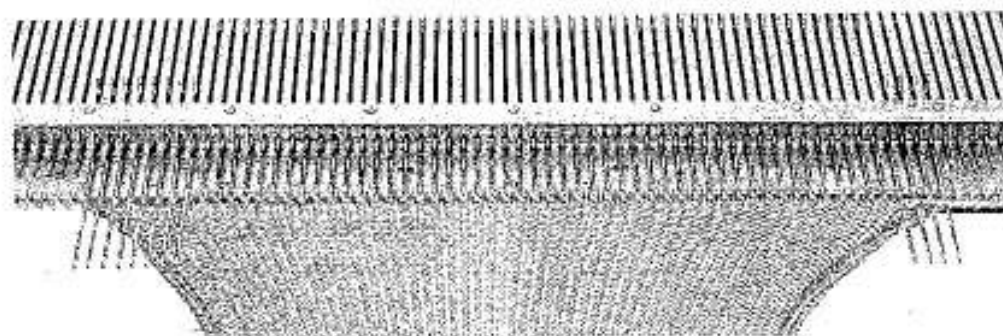

Take the yarn under the 4th needle INSIDE the knitting at the RIGHT and on top of the other 3 needles in D position. At the LEFT bring 4 more needles from B to D position (see photo).

DARTS — IN PLAIN KNITTING AND PATTERNS

NOTE: PLAIN KNITTING. Move the carriage past the needles in B position, but far enough to work the Row Counter.

PATTERNING. Move the carriage far enough so it passes the pattern panel completely.

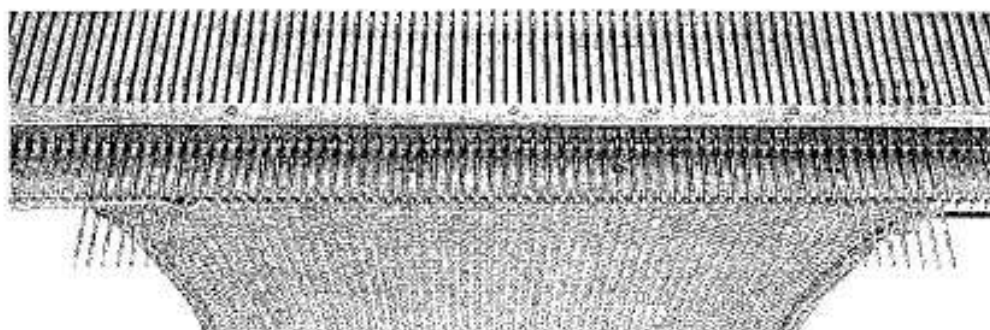

Knit 1 row towards the LEFT. Take the yarn UNDER the 8th needle inside the knitting in D position and let it lie on top of the other 7 needles.

Bring 4 more needles at the RIGHT into D position.

Knit 1 row. Take the yarn UNDER the 8th needle inside the knitting at the RIGHT.

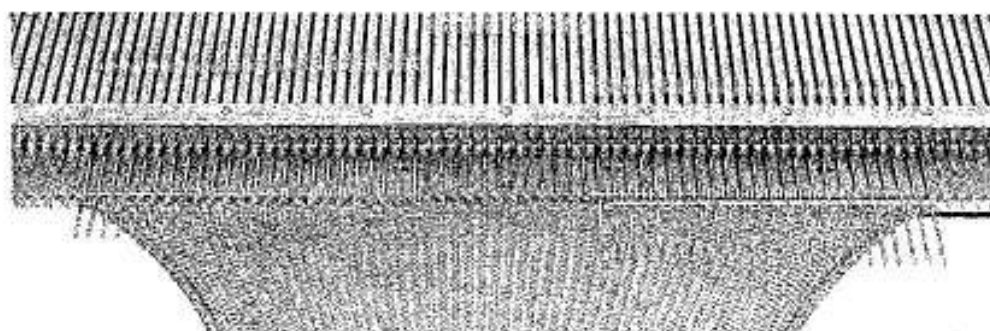

Proceed as above until you have 12 needles in the center of the knitting in B position. The carriage is at the RIGHT.

PLAIN.

Using the straight edge Needle Pusher, bring the needles at LEFT of center from D to C position.

Knit 1 row towards the LEFT. The Row Counter shows 43.

PATTERNING.

Move the carriage further to the RIGHT — PAST — the needles in D position. Break the yarn and fasten the new end on to the Table Clamp.

The row indicator shows 35 and the Row Counter 42. Using the Transfer Tool, bring the needles from D to B position. The stitches are in the needle hooks. Continue knitting. After finishing, you can secure the the loose thread to the wrong side of the knitting.

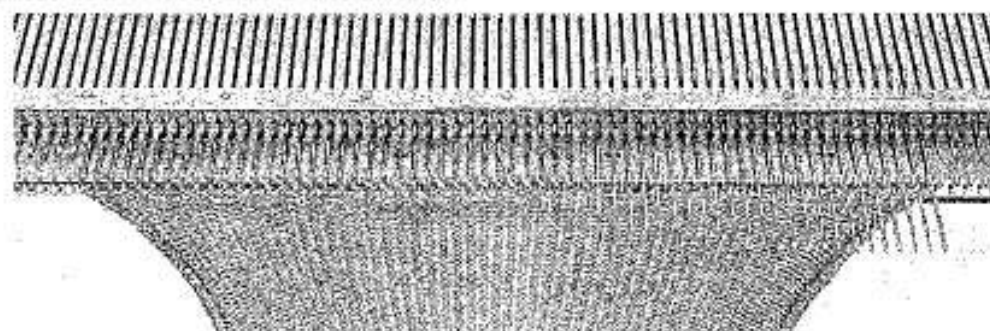

PLAIN.

The needles from C position are knitted back to B position. Push the needles at the RIGHT from D to C position.

Knit 1 row. These needles are also knitted back to B position.

Knit another 8 to 10 rows. You can see quite clearly where the darts have been knitted.

3 DIFFERENT SHOULDER SHAPINGS

PLAIN

Card release to ● .

Carriage settings are:

1. Tension Dial to 7,
2. Side Levers to FRONT,
3. Cam Lever to center 0,
4. Front Levers to I,
5. Arm Levers to ▽ .

Cast-on open edge 30 needles and knit 29 rows.

The carriage is at RIGHT and the Row Counter shows 30.

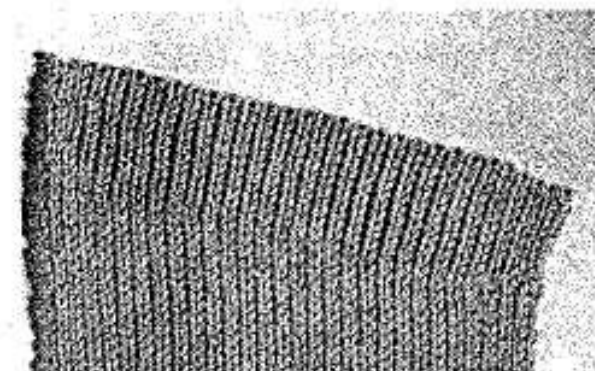
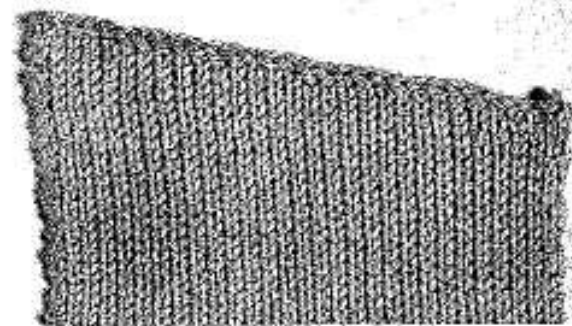
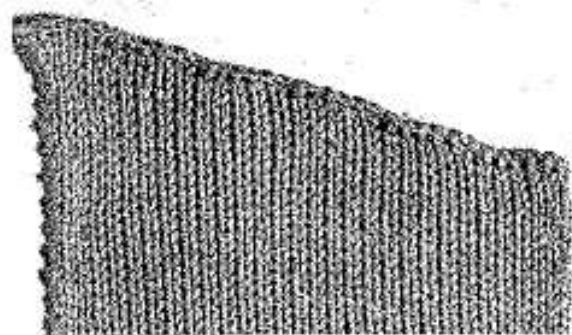

PATTERNING

Same settings as for plain knitting. Cast-on open edge 30 needles and knit 6 rows.

Carriage at LEFT, Row Counter shows 7.

Set card release to ▼ and Side Levers BACK.

Take card 3 and insert it - A at RIGHT bottom.

Secure ends of card and turn 56 to row indicator.

Knit pre-setting row 56 to the RIGHT.

Row indicator shows 1 and Row Counter 8.

Set Cam Lever to T and knit 22 rows.

Row indicator shows 23 and Row Counter 30.

Carriage is at RIGHT.

METHOD 1.

Knit 1 row to the LEFT.

At LEFT, cast-off 5 stitches, knit 2 rows.

Repeat from * to * 4 more times.

Row indicator shows 34 and Row Counter 41.

Cast-off the remaining 5 stitches and break

the yarn.

METHOD 2.

Cast-on and knit as above until Row Counter shows 30 - in Stitch pattern, row indicator 23, Front Levers are set to I.

At LEFT, bring 5 needles to D position, Knit to LEFT, bring yarn under inside needle in D position, Knit to RIGHT.

Repeat from * to * 4 more times, Carriage at RIGHT.

Row indicator shows 33 and Row Counter 40.

Set Tension Dial to 10.

Using straight edge Needle Pusher, bring the 25 needles back to C position.

Cam Lever to center, knit 1 row to the LEFT.

Using Latcher Tool, cast off all stitches.

METHOD 3.

Same as Method 2 until you have 25 needles in D position, Row Counter shows 40 and if doing Stitch pattern, row indicator shows 33.

Using straight edge Needle Pusher, bring the 25 needles from D to C position.

Cam Lever to center, knit 1 row to the LEFT.

The needles are knitted back to B position.

Remove main yarn and thread waste yarn.

Knit several rows of waste yarn and remove the knitting from the machine.

When finishing the garment, unravel the rows of waste yarn and graft the shoulder seam.



BUTTONHOLES FOR SMALL BUTTONS

If you are using a thin yarn, the buttonhole over 2 needles will be quite small. A thin yarn knitted on Tension 5 will give about 1/4 inch buttonhole. Heavy yarn knitted on Tension 10 will give a buttonhole about 1/3 inch. Decide the position of the buttonhole.

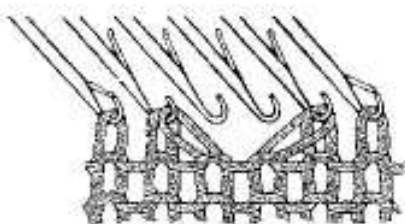

Where a buttonhole is required - transfer 1 stitch to the adjacent needle on each LEFT and RIGHT side. Leave the empty needles in B position.

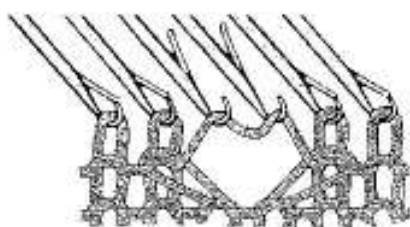

Knit 1 row - the yarn lies loosely over the 2 empty needle hooks.

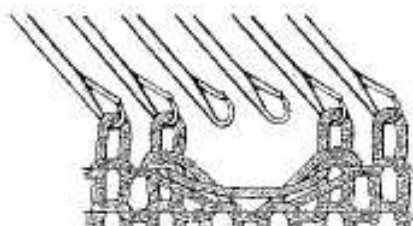

Bring these empty needles to D position and then back to B position - leaving the loose thread in front of the Sinker Gate.

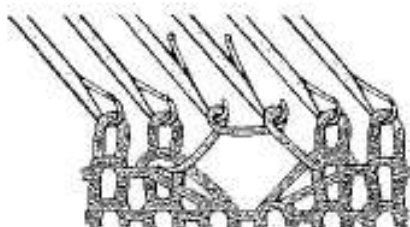

Bring the LEFT needle a little to the front, just out of the Sinker Gate, open the latch so that you are able to wind the thread in a counter clockwise direction around it.

Pull the needle back to B position. Repeat the same with the second needle.

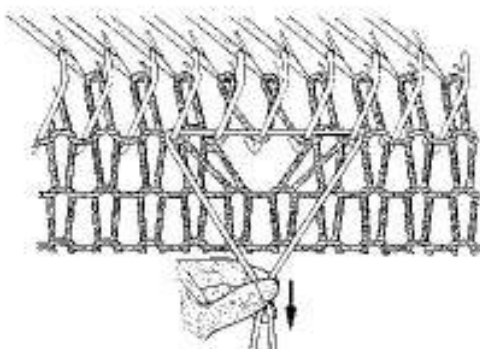

Lay the Nylon Cord across the new loops and the stitches of the adjacent needles on each LEFT and RIGHT side - between the needle hooks and the Sinker Gate.

Pull both ends of the Nylon Cord down and knit 2 to 3 rows.

Pull the Nylon Cord out of the knitting. Continue knitting and repeat the buttonhole where required.

LARGE SINGLE BUTTONHOLE



To make this buttonhole you will need a thread about 5-10 inches long of the same yarn you are knitting with.

Describe the position of the buttonhole - you will knit it over 7 needles in the diagram they are numbered from 1 to 7.

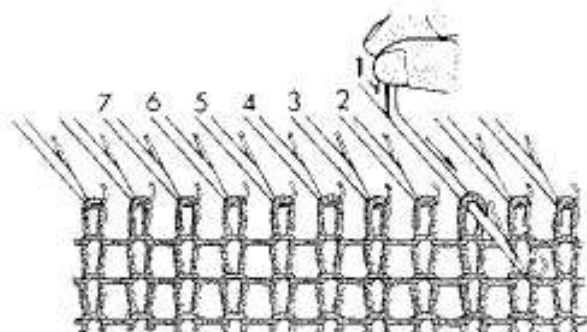

Push needle 1 from B to D position. The stitch will slide behind the latch and the hook is empty.

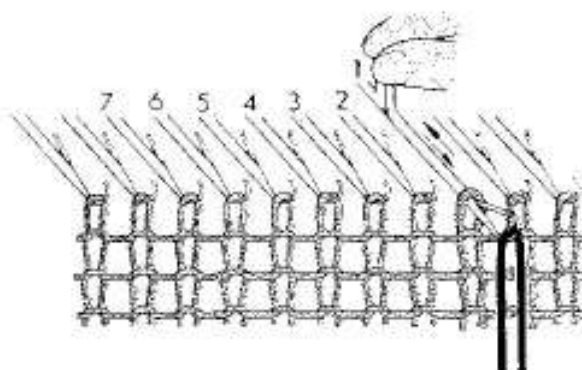

Hang the loose thread of yarn across the empty hook and pull the needle back to B position. You have now knitted 1 stitch by hand with needle 1.

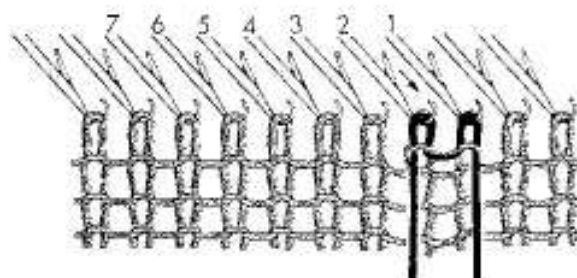

Push needle 2 to D position and knit in the thread in the same way.

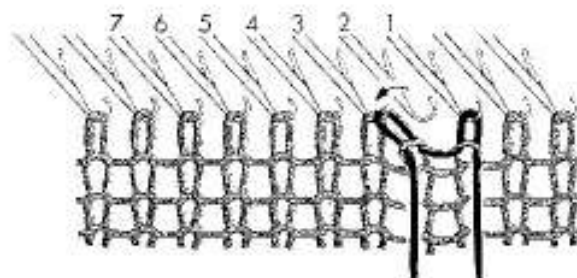

Now transfer the stitch from needle 2 on to needle 3. Push needle 3 (which has 2 stitches) up to D position.

LARGE SINGLE BUTTONHOLE

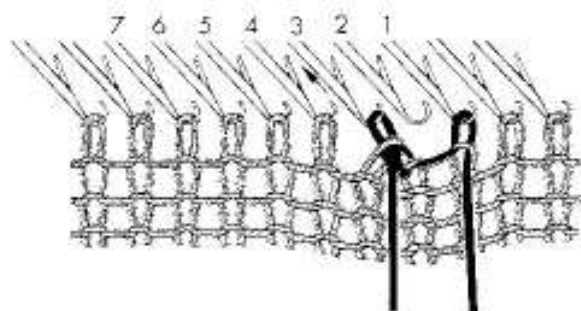

Lay the yarn across the empty hole, as in 1. Take the 3 back to B position. You have started the yarn through both stitches.

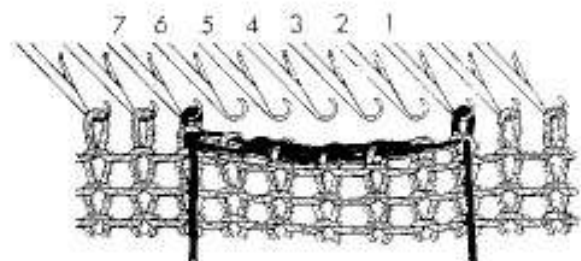

Transfer the position of needle 4 from position B to needle 4 to B position and knit over making all stitches until 5 needles are empty and needle 4 is on needle 7.

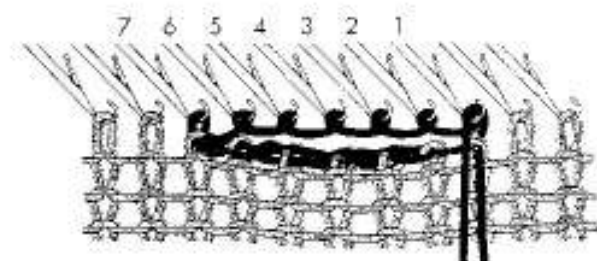

The empty needles are in B position. Draw the catches of those needles. Bring needle 6 out to the front, just out of the Sinker Gate and lay the yarn in a counter-clockwise direction around it. Pull the needle back to B position. Repeat with needles 5, 4, 3, 2 and 1. The needles with the new catches are in line with all other needles.

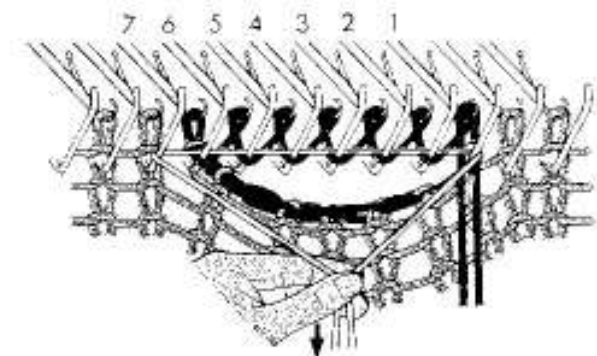

Take the Nylon Cord and lay it across the top and the 7 needles, between the needle hooks and the Sinker Gate. Pull the Nylon Cord down at both ends and knit 3 rows. Pull off the Nylon Cord. The buttonhole is now completed.

NOTE: You can use this method to make a different hole of any size by increasing or decreasing the number of stitches that are knit off.

THE DOUBLE BUTTONHOLE BAND

This buttonhole can be knitted as wide as you wish - and it can be used for a separately knitted cardigan band.

For a jacket or cardigan band, cast on 22 needles closed or open edges and knit 20 rows using a stitch size 2 points TIGHTER than used for the main garment.

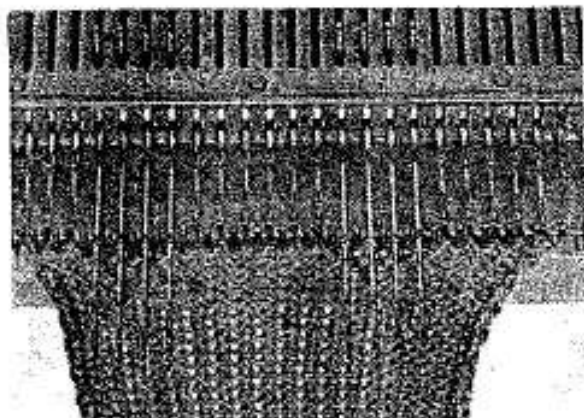

Starting from the RIGHT - bring needles 6, 7, 8, 9, 16, 17, 18 and 19 from B to D position

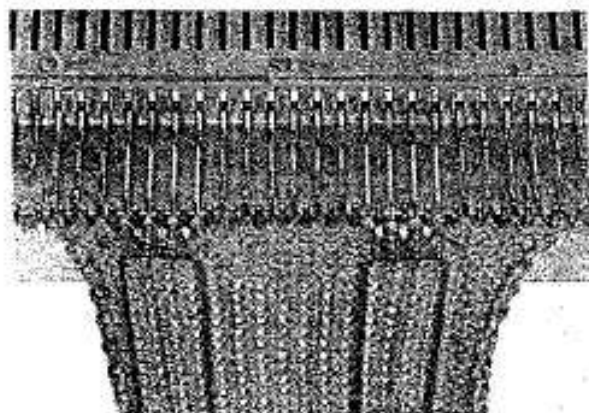

Lay the contrasting thread over each block of 4 needles in D position. Hold both threads down while carefully pushing the 2 groups of needles back to C position until the latches close over the thread.

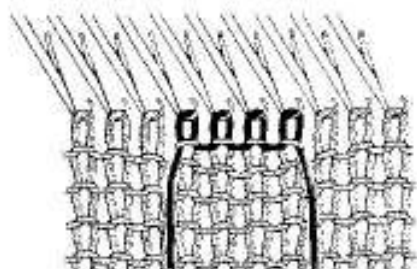

Now let the threads hang down and starting with the first needle from the RIGHT in C position, push the needles back - one by one - until BOTH groups of 4 needles have hand knitted stitches and are in B position.

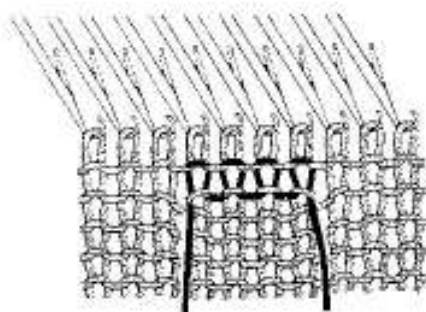

Knit 1 complete row. The contrasting thread should now be knitted in as shown in this illustration.

Knit the required number of rows and repeat the buttonhole.

FINISHING THE DOUBLE BUTTONHOLE BAND

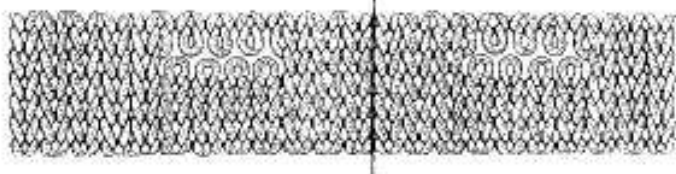
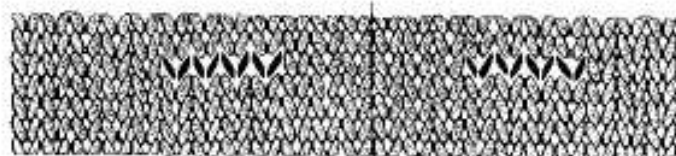

The line shows where the cardigan band will be folded back.

The stitches shown in red are those which you knitted in by hand.

Steam the band and pull out the contrasting yarn from the band.

Thread up tapestry needle with matching yarn and secure thread inside of band.

Fold band, have the edge with the 3 stitches at the top.

Finish buttonhole as shown in the following 14 diagrams.

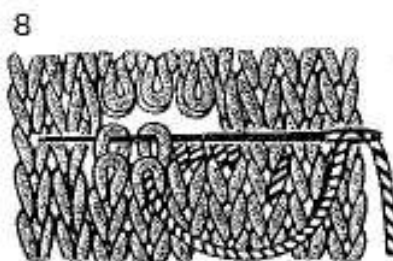
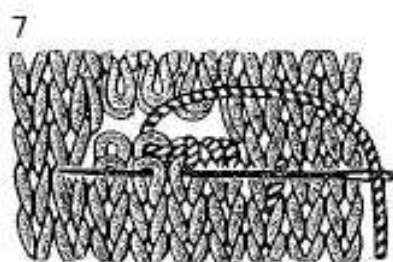
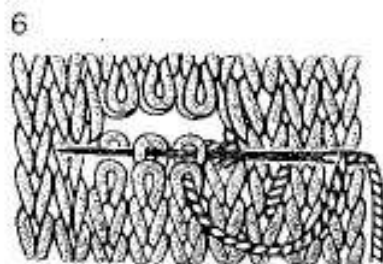
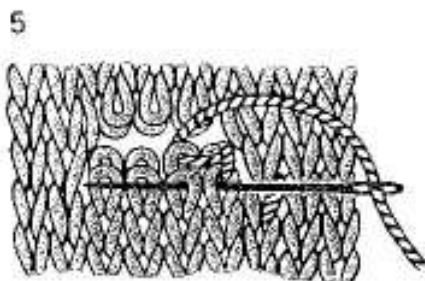
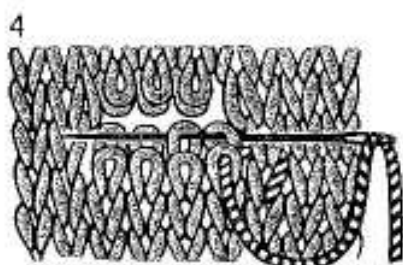
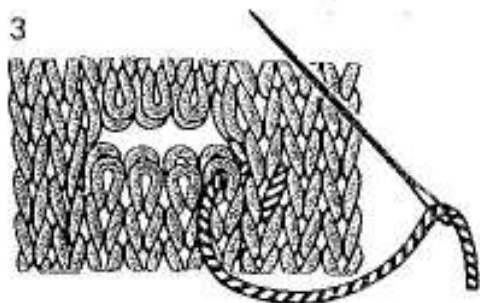
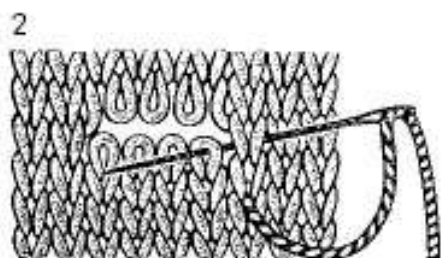
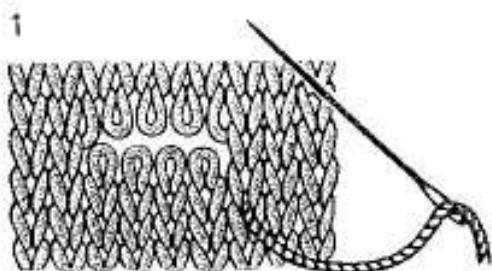

FINISHING THE DOUBLE BUTTONHOLE BAND

9

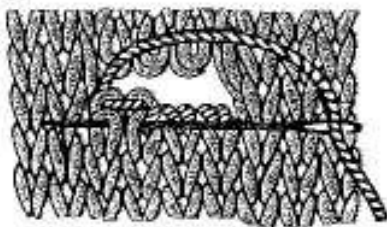

12

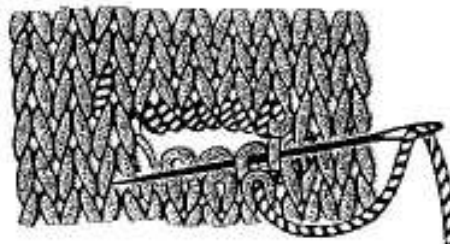

10

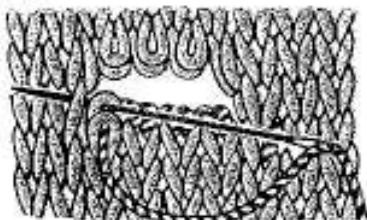

13

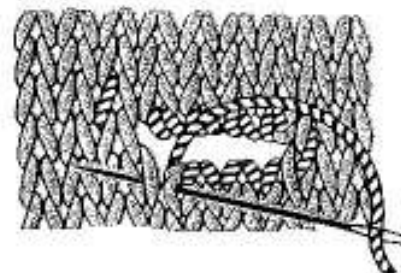

11

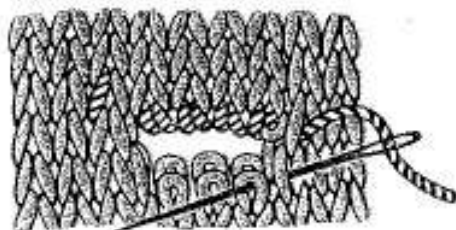

14

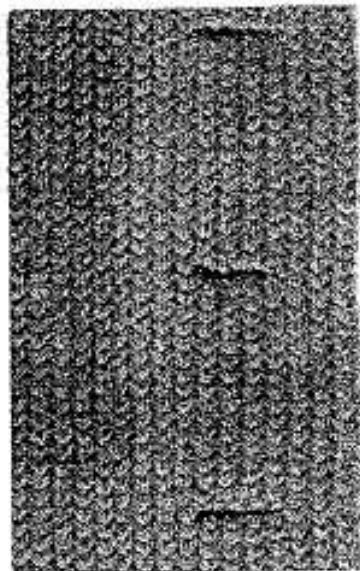
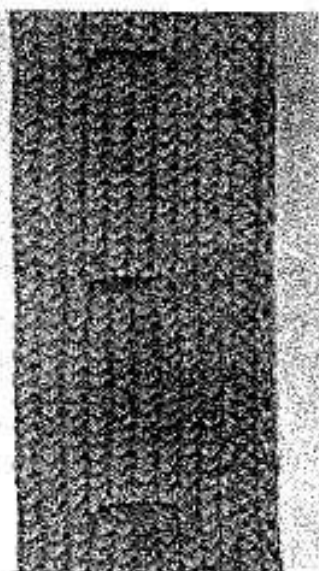
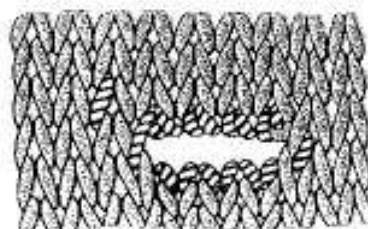

1. This is your buttonhole band completed.
2. Sew the edge with 5 stitches on to front of garment using Mattress stitch.
3. Turn out wrong side of garment and catch down to the seam the narrow edge of the buttonhole band.

KNITTING

STEP

3



Helpful Hints	80 - 88
How to change a needle	80 - 89
Maintenance of machine	90
Repacking the machine	91
General Index	119 - 120

USEFUL HINTS

CASTING—ON PROBLEMS:

When you cast-on it is necessary to begin with a Tension of 7 or higher.

This gives you a large loop between the Sinker Gate and the needle hook. When you lay the Nylon Cord across these loops, it is easy for you to pull the Nylon Cord well below the needle hooks. Therefore the hooks can pass the Nylon Cord when knitting the next row.

If the stitches of the first row are too tight or if you do not pull the Nylon Cord down TIGHTLY, then when you knit the next row, the Nylon Cord may be knitted in or the carriage may jam, in either case you will have to cast-on again.

STITCHES NOT KNITTED AT THE EDGES:

If you return the carriage BEFORE the Sinker Arm plate HAS PASSED THE LAST NEEDLES IN POSITION, it is possible that the first stitches in the row may NOT knit.

DROPPED STITCHES AT THE EDGES:

Dropped stitches will occur at the sides of the knitting if your Yarn Brake is not properly threaded and your Take-up Spring is NOT automatically taking up all slack yarn between the Feeder mouth and the needles. Loose loops may also form on the sides.

Dropped stitches or loose loops may occur at the sides of the knitting if you move the carriage TOO far past the knitting after knitting a row. TOO MUCH yarn is pulled from the Yarn Brake and you have slack yarn between the carriage and the knitting.

This can be easily avoided if you just pull down any slack yarn from behind the Yarn Brake or if you move the carriage just until the Sinker Arm plate has passed the last of the needles in knitting position.

DROPPED STITCHES IN PLAIN KNITTING:

Can be caused by:
Too loose or too tight a Tension,
A Tension unsuitable for the pattern,
Yarn not suitable for the pattern.

DROPPED STITCHES WHEN DOING STITCH PATTERNS:

It can happen that you have dropped stitches when knitting Fair Isle or Lace patterns. In this case check if the thread of colour 2 or the nylon thread is properly threaded in Feeder 2 and at the LEFT of the Feeder Guide pin.

Dropped stitches can also be caused by a knot in the yarn, or by yarn which has been badly or too tightly wound, thus preventing the smooth flow of the yarn from the ball to the knitting.

USEFUL HINTS – REPAIRING A DROPPED STITCH

As soon as you notice a dropped stitch, you should repair it at once.

If the dropped stitch is only 1 row back use this method.

1

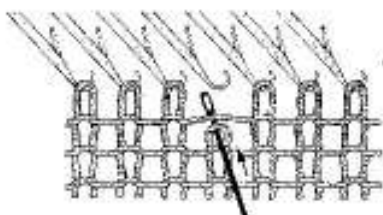

Insert the Transfer Tool inside the dropped stitch,

2

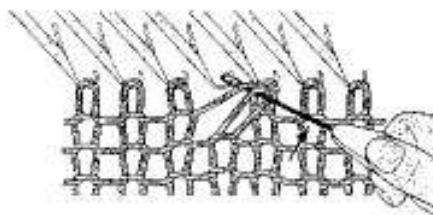

Hook the Transfer Tool into the empty needle. Lift the loose bar of yarn and the stitch on to the empty needle.

3

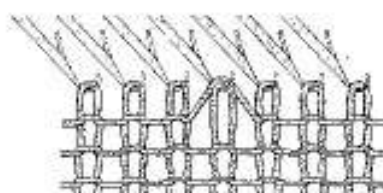

There is now 1 stitch and 1 bar on the empty needle.

4

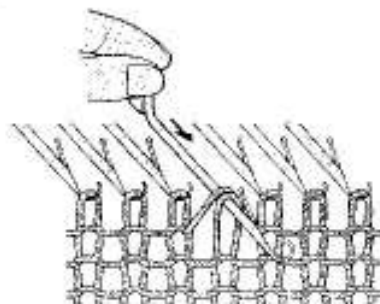

First, push the needle up to D position, then pull the needle slightly back - just until the bar and the stitch are behind the latch - then STOP.

5

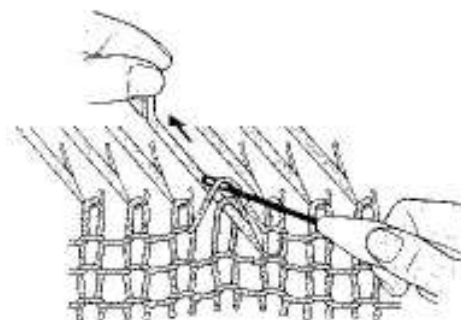

With your single Transfer Tool, lift the loose bar of yarn over the latch INTO the hook and leave the stitch BEHIND the latch.

6

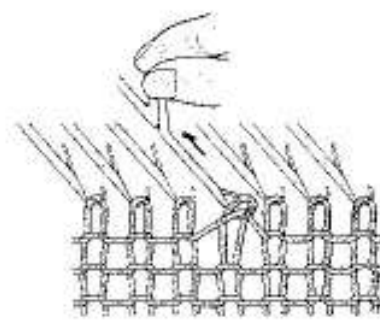

Pull the needle back down to B position thus pulling the bar of yarn through the stitch.

7

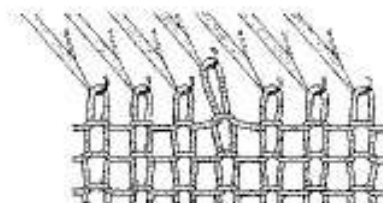

Push the needle further back to A position to enable it to form a bigger stitch.

8

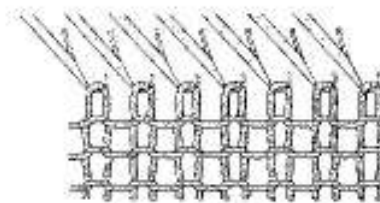

Pull your knitting down and sideways until gradually the newly repaired stitch assumes the same shape as all other stitches.

USEFUL HINTS

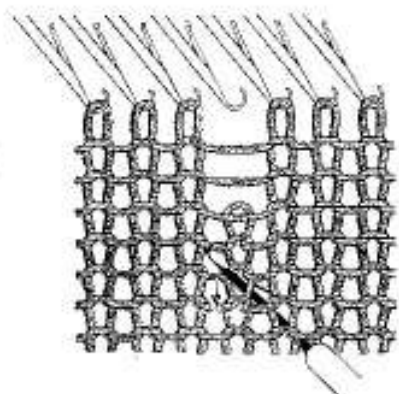

If a dropped stitch is several rows back then follow this method.

Insert the Latchet Tool from behind your knitting through a stitch a few rows below the dropped stitch.

Undo stitches down to the Latchet Tool by pulling down on the Latchet Tool.

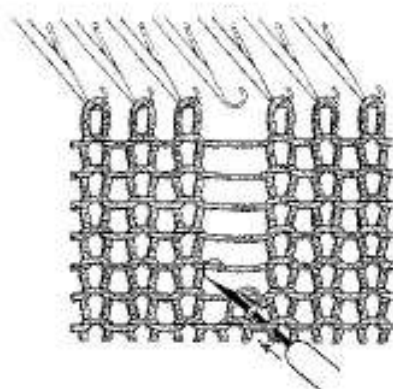

Push the Latchet Tool towards you so that the stitch comes behind the latch, and the hook catches the cross thread.

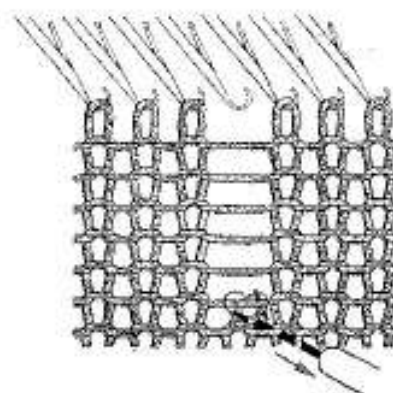

Draw the Latchet Tool back. The cross thread is trapped in the closed latch. Pull the cross thread through the loop thus forming a knitted stitch.

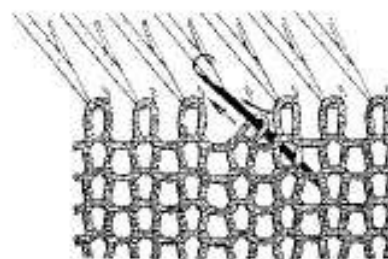

Push the Latchet Tool towards you until the stitch is behind the latch. Catch the next cross thread in the hook and pull it through the stitch. Repeat until you reach the top.

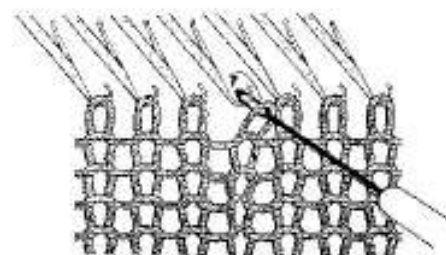

Pull the last stitch rather tight to make a bigger loop. Insert the Transfer Tool into this loop from the front. Carefully pull the Latchet Tool out of the stitch and with the Transfer Tool replace the stitch on to the needle.

USEFUL HINTS

UNRAVELLING

IT MAY BE NECESSARY TO UNRAVEL –

If you have knitted too many rows.

If you have made a mistake in the knitting.

If your carriage jams and it is necessary to release the carriage and restart the row where the fault occurred.

If you have more than one dropped stitch in the middle of a row, it is much easier to unravel 2 or 3 rows and then just lift the dropped stitches back on to their respective needles.



TO PRACTICE UNRAVELLING –

Cast-on 40 stitches in the normal way.
Knit 20 rows finishing with the carriage at the RIGHT.

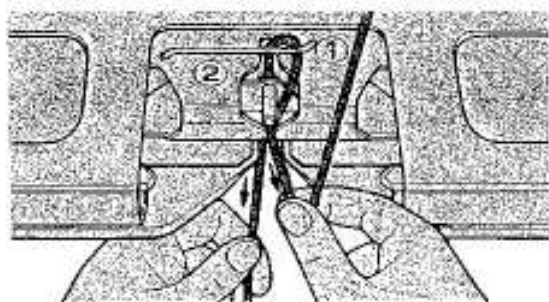

TO UNRAVEL 4 ROWS PROCEED AS FOLLOWS:

Remove the yarn from the Yarn Feeder.

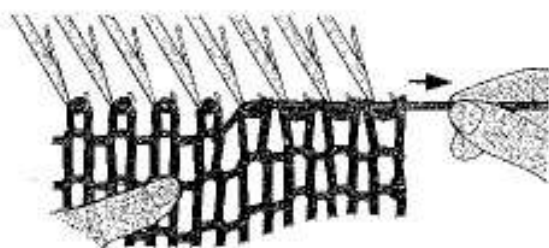

Hold the knitting with your left hand and with your right hand pull the yarn sideways as illustrated.

NOTE: When unravelling Fair Isle, Weaving and Lace patterns, you will have to unravel TWO threads.

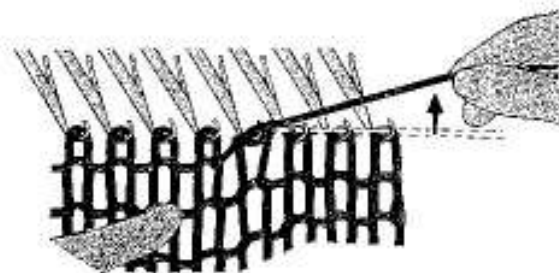

Lift the yarn upwards and very slightly backwards and you will notice that the stitches of the previous row automatically slide back into the needle hooks. Bring the needles back to B position.

Repeat pulling the yarn and lifting the stitches of the previous row into the needle hooks until you have unravelled 4 rows. When unravelling from the LEFT you must pull the thread towards the LEFT.

After unravelling rows - bring all needles in a straight line in B position.

UNRAVELLING

When you have unravelled a few rows, this will leave quite a considerable length of loose yarn. Thread the yarn back into the Yarn Feeder. Pull back all loose yarn down from the Yarn Brake on to the ball of yarn as shown on Page 21. Move the carriage nearer the needles in B position, pull down the slack yarn behind the Yarn Brake and proceed to knit.

DO NOT FORGET TO SET BACK THE ROW COUNTER FOR THE NUMBER OF ROWS UNRAVELLED.

YOU CAN ONLY UNRAVEL WHEN ALL YOUR STITCHES ARE INSIDE THE NEEDLE HOOKS.

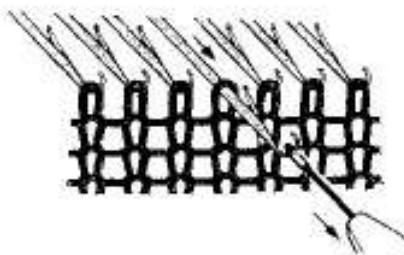

If for any reason, one or more of the stitches are not in the needle hooks and are behind the latches, hang the Transfer Tool in the needle hook. Pull the needle into D position.

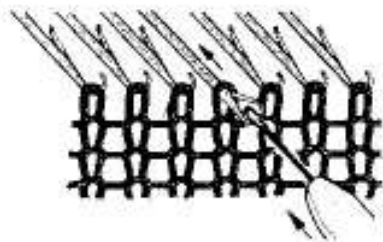

Push it back to A position, the stitch is on the Transfer Tool. Pull the needle into B position.

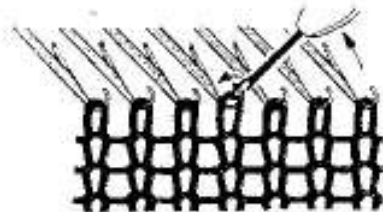

Raise the Transfer Tool and let the stitch slide into the needle hook. When you have brought all needles to B position this way, then you may start unravelling.

THE CARRIAGE IS HARD TO MOVE IF –

1. The yarn is wound too tightly and does not flow easily into the needles. The yarn you are using is too bulky or too heavy. The yarn is not suitable for the pattern which you are knitting.
2. The Tension (stitch size) is either too loose or too tight.
3. Your machine is dirty or needs oiling.
4. The Yarn Brake has been incorrectly threaded.
5. The yarn has tangled in the Yarn Brake during knitting.



USEFUL HINTS - IF THE CARRIAGE JAMS

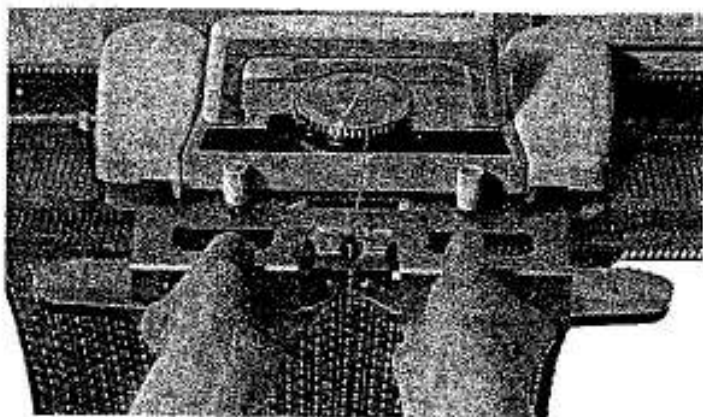

SOMETIMES THE CARRIAGE MAY JAM IN THE MIDDLE OF A ROW. IT IS NOT SERIOUS – BUT DO NOT FORCE OR HIT THE CARRIAGE TO GET IT LOOSE – PROCEED AS FOLLOWS:

1. Loosen BOTH thumb screws on the Sinker Arm until they are wide open.
2. Raise the Sinker Arm UPWARDS.

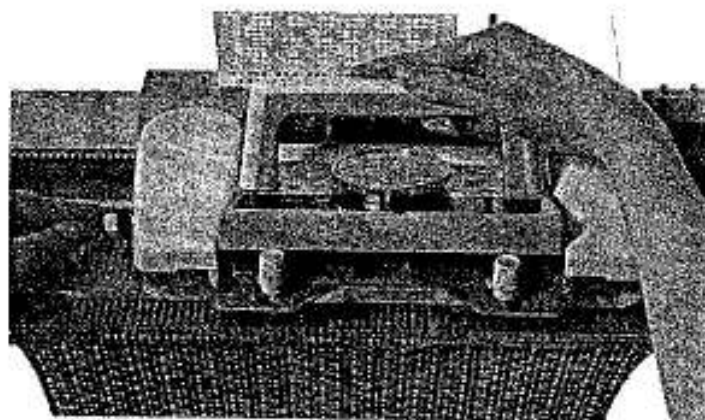

3. Ensure there are NO NEEDLE HOOKS CAUGHT IN THE YARN FEEDER.
4. Pull the Sinker Arm TOWARDS you - removing it from the carriage.
5. Remove the yarn from the Yarn Feeder.
6. If knitting a Stitch pattern, set Cam Lever to centre 0.
7. Set BOTH Side Levers to the FRONT.
8. Lift the handle BACKWARDS, the carriage handle will raise.
9. In proceeding direction of carriage, (the direction in which you were knitting) hold the Side Lever to the FRONT, lift the carriage plate and slide the carriage OUT of the knitting, lower the carriage plate.

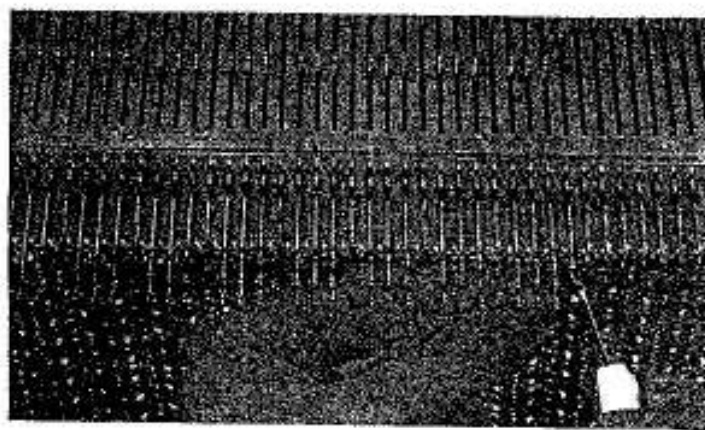

10. Carefully unravel the already knitted stitches. Using Transfer Tool, bring the needles from C to B position, (opposite page).
11. Turn pattern card 1 row BACK (20 to 19) and set card release to ●.

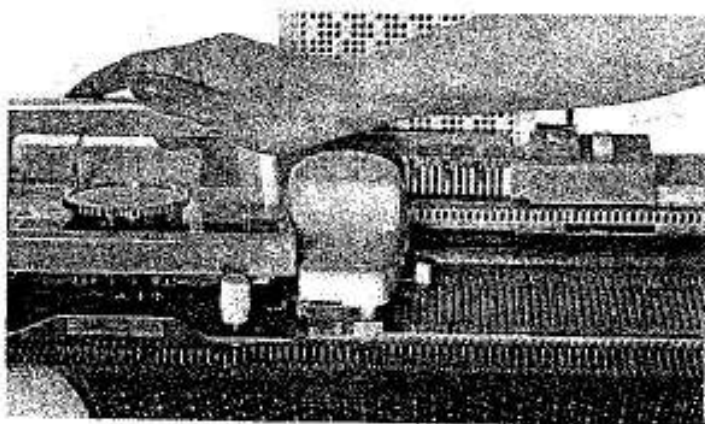

12. Lift the carriage plate UP and move the carriage to the opposite side of the knitting.
13. Attach Sinker Arm to the carriage and re-thread the yarn, check the yarn tension.
14. Set card release to ▼.
15. Set Cam Lever to required pattern position and set Side Levers BACK.
16. Set Row Counter 2 rows BACK and continue knitting.

REASONS WHY THE CARRIAGE MAY JAM

THE YARN MUST ALWAYS FLOW SMOOTHLY AND EASILY INTO THE NEEDLES AS THE CARRIAGE IS MOVED ACROSS THE NEEDLE BED.

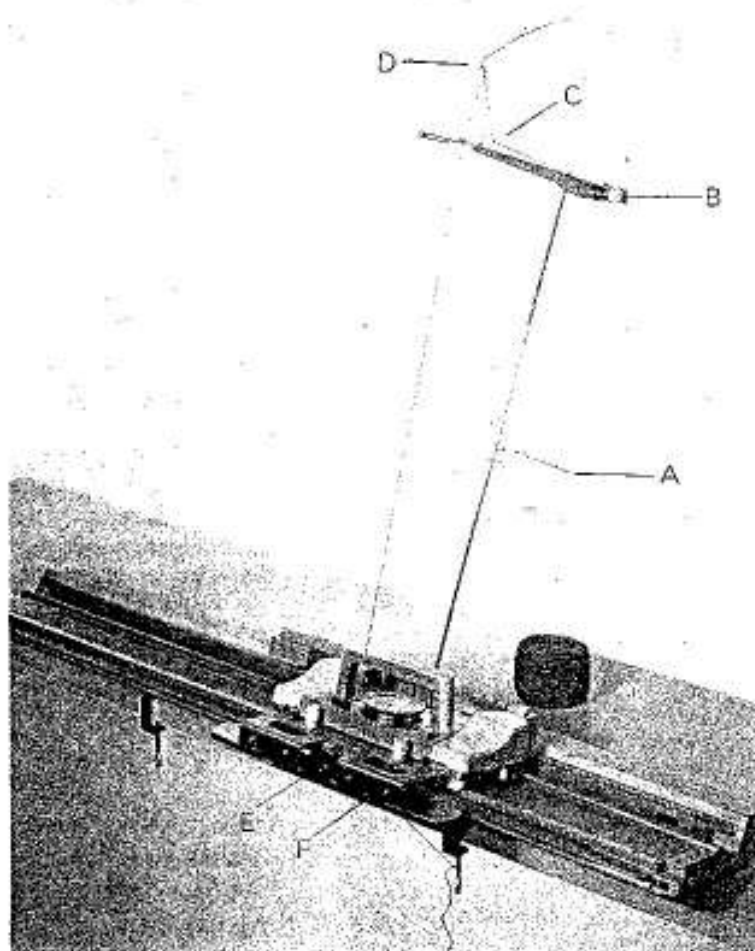

1. IF FOR ANY REASON THE YARN CANNOT FLOW INTO THE NEEDLES, THE CARRIAGE WILL JAM IMMEDIATELY.
2. It may be blocked at points A, B, C, D or E if it is not correctly threaded or if there is a large knot in the yarn or if the yarn is twisted around the points just mentioned (see photo).
3. Underneath the Sinker Arm Assembly are 4 brushes F. The yarn may become caught in the brush wheels F if there is any slack yarn between the Yarn Feeder E and the needles.

It is easy to find out why your carriage jammed. Pull the yarn below the carriage down. If it does not flow smoothly then check all points mentioned above.

If the yarn does flow smoothly - the reason for the jamming is NOT ABOVE the carriage.

Check the brushes below the Sinker Arm Assembly to see if there is yarn twisted around them. Move the carriage away from the knitting and place the Sinker Arm Assembly back on to the carriage ensuring that both thumb screws are tightened. When you unravel the last row, check the yarn Tension. Make sure the yarn is on the Sinker Arm plate and continue knitting.

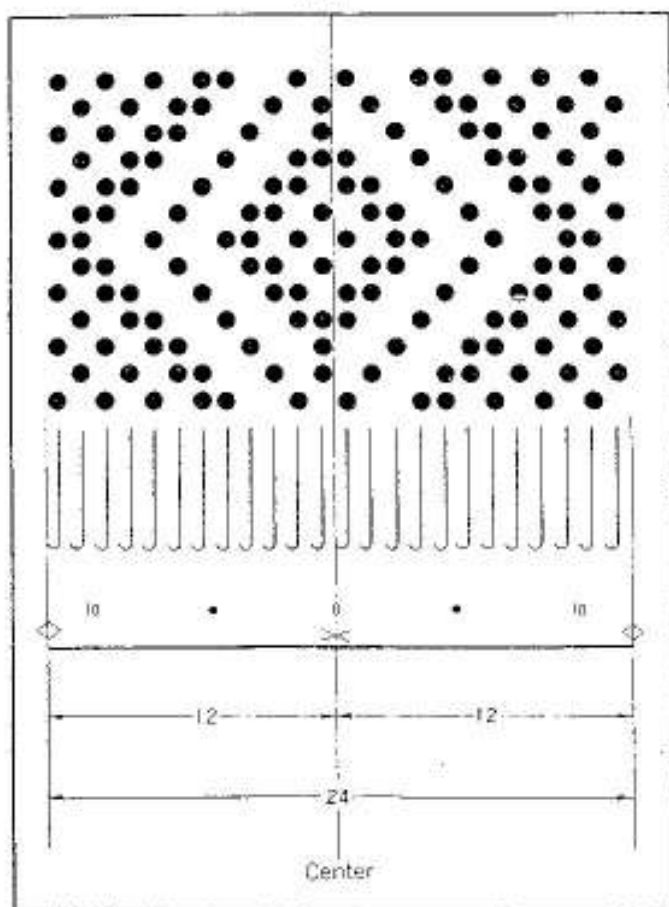

THE RELATION BETWEEN THE CARD AND THE MARKINGS ON THE NEEDLE BED.

On the needle number plate are markings X and \diamond .

X indicates the center of the punch card,

\diamond indicates the width of the card (24 needles),

Between the markings X and \diamond are 12 stitches, which is HALF the width of the card,

These markings can be very useful to adjust the pattern at the edge when knitting panels.

THE CARRIAGE IS ACCIDENTALLY PULLED OFF THE NEEDLE BED WHEN DOING STITCH PATTERNS – GIVE PATTERN MEMORY BACK AS FOLLOWS:

In the above case set card release to ● .

Remove the yarn from the Feeder, Set carriage on to the needle bed at the opposite side, Set Cam Lever to S, Set Side Levers to FRONT and Front Levers to I. Move the carriage over the knitting to the other side, Set Card release to ▼ Cam Lever to pattern position, Side Levers BACK, Row Counter 1 row BACK, thread yarn and continue knitting.

Operation of touch lever	Perforated area of punched card (Touch lever rises) Needle comes out	Unperforated area of punched card (Touch lever lowers) Needle goes back
Tuck knitting	Knit	Tucked (Non-knitting, yarn is over the hook)
Slip stitch	Knit	Slipped (Non-knitting, yarn crosses in front)
Fair Isle (Knit-In)	Knit with yarn from yarn feeder 2	Knit with yarn from yarn feeder 1
Weaving	Weaving yarn is threaded above.	Weaving yarn is threaded below.
Punch lace knitting	Knit nylon thread.	Knit nylon thread and yarn together.

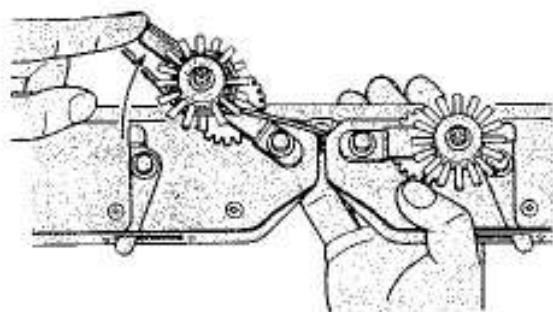

THE YARN IS WOUND AROUND THE BRUSH WHEELS.

If you have yarn caught around the Brush Wheels below the Sinker Arm, remove the Sinker Arm from the carriage as explained on Page 85.

Turn Sinker Arm upwards and push the Brush Wheels as illustrated. Pull the yarn off the Brush Wheels.

Return the Brush Wheels below the Sinker Arm and attach the Sinker Arm to the carriage.

If you move the Brush Wheels too much out of the Sinker Arm, the little white wheel may fall off its stud, but it very easy to replace it.

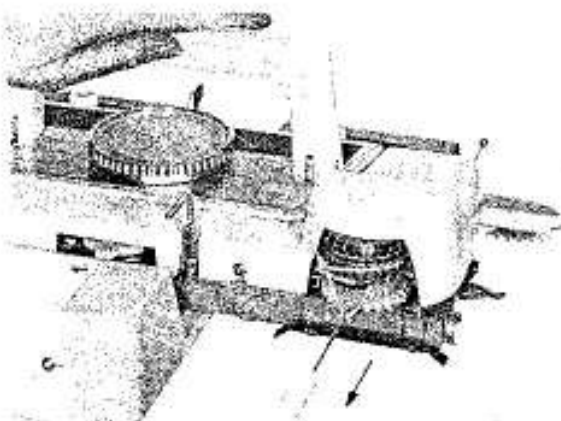
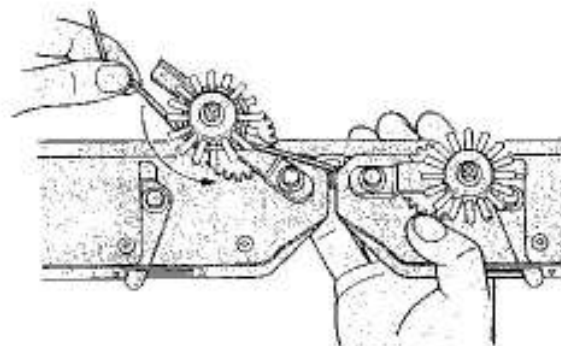

THE YARN ENTANGLED IN THE PATTERN MEMORY.

While knitting - ALWAYS have the immediate rear of the machine clear of yarn.

But still it happens that sometimes the thread gets entangled inside the pattern memory.

This will of course result in faulty pattern knitting.

Move the carriage HALFWAY off the needle bed to free the required pattern memory.

With your Latchet Tool, carefully pull the yarn from the inside.

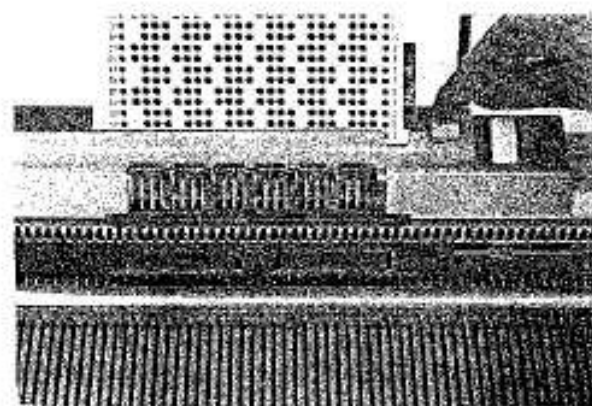

THE RELATION BETWEEN THE PUNCH CARD AND THE TOUCH LEVERS.

If the card release is set to ●, the touch levers show the pattern setting you will knit next.

If you wish to see the setting of the previous row, turn the card 1 row BACK and set the card release to ●.

NOTE: When the card release is set to ●, the feeding dial will NOT operate.

CHANGING A DAMAGED NEEDLE

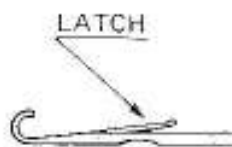

Needles with damaged latches will cause faulty knitting or dropped stitches and therefore must be changed.

The needle latch must move easily and lie flat over the needle hook.

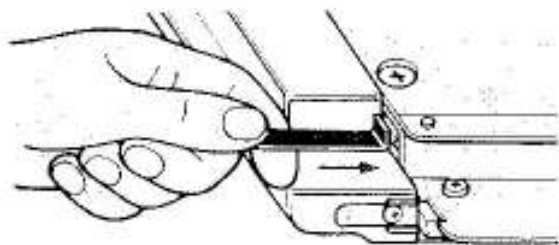

If the damaged needle is at the LEFT half of center - push the raised end of the cooper plate into the needle bed at the LEFT.

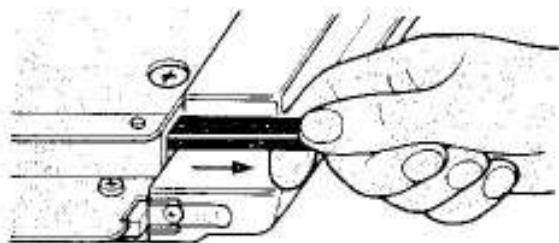

The needle retaining bar is now pushed out of the needle bed at the RIGHT and you can pull it out of the needle bed until the damaged needle lies free.

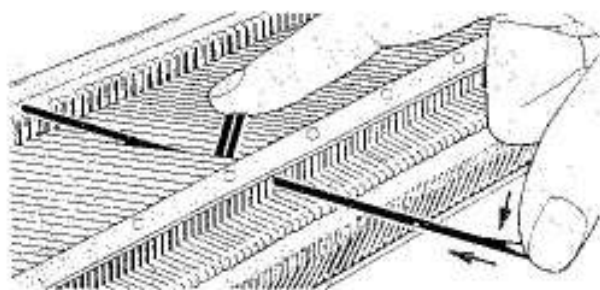

Push the damaged needle by the butt up to D position. With your thumb, push the needle hook down as shown, unless the needle is badly worn the heel will lift out of the needle bed. If NOT, use the work hook. Slide it inside the needle bed from the top and bring the shank of the needle below the opening of the needle bed to let it come out. Hold the heel of the damaged needle, close the latch, and pull backwards out of the needle bed.

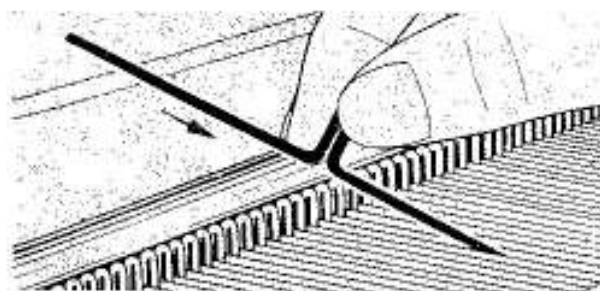

Open the latch of the new needle and slide it into the groove of the needle bed as shown by the arrow. The needle must come to D position. Then you let the shank slide into the needle bed, move the needle backwards to A position.

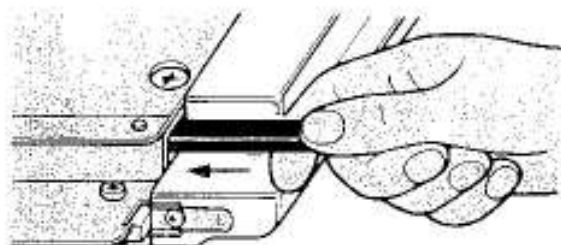

Check that the needle slides smoothly in the needle bed from A to D position.

Now insert the needle retaining bar inside the needle bed as shown.

MAINTENANCE OF THE MACHINE

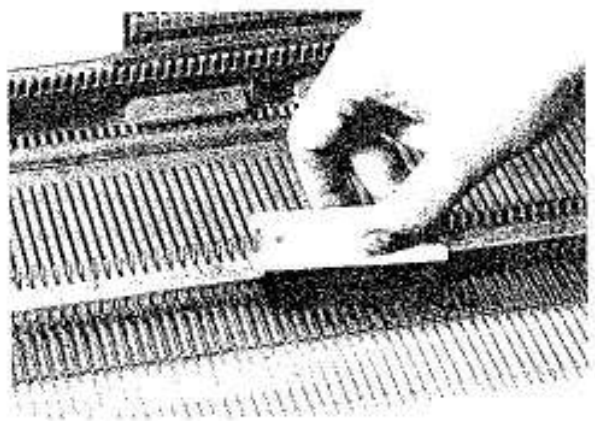

To clean the machine - remove the carriage from the needle bed completely. Bring all needles up to D position and with the little brush remove all lint from the needle number plate.

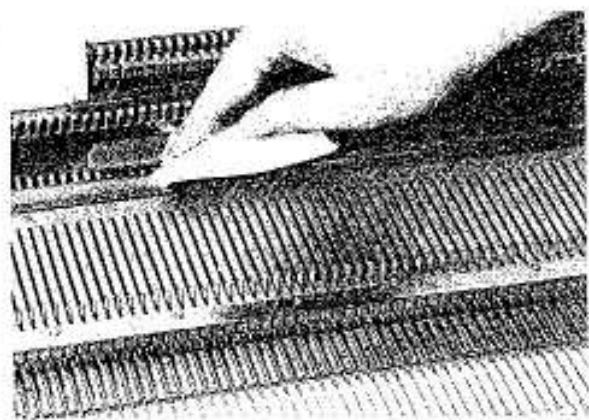

Remove any lint that may be around the brushes below the Sinker Arm Assembly.

With a paper tissue or a soft dry cloth remove oil from Guide Rail of machine and from below the carriage.

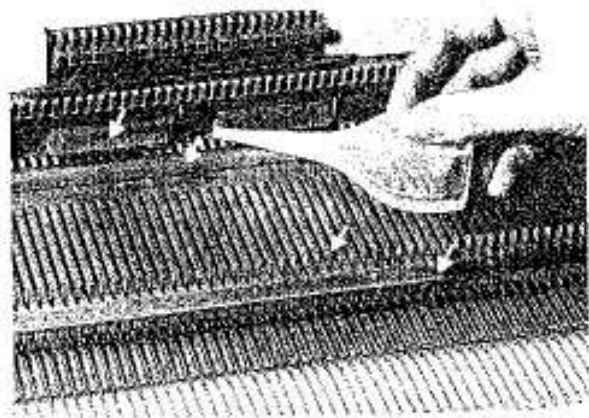

When starting to knit - slide the oil bottle along the Guide Rail of the machine, the needle butts and the front guide of the needle bed.

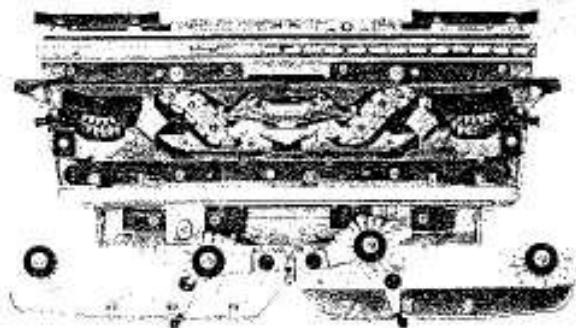

The dotted line shows you where the parts below the carriage need oiling before knitting. Oil lightly.

—REPACKING THE MACHINE

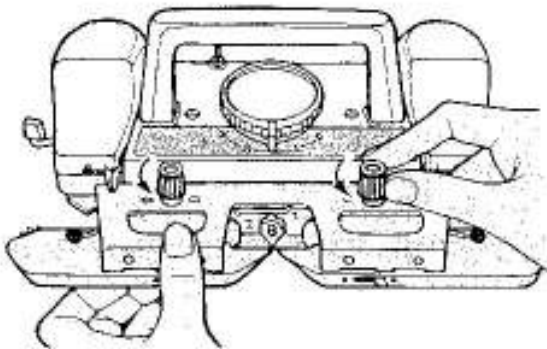

Remove the Sinkers from the carriage front.

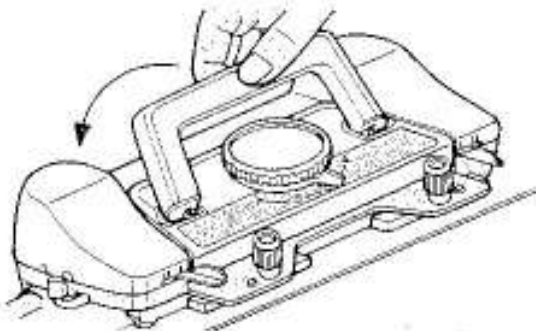

Snap the handle down flat on the carriage.

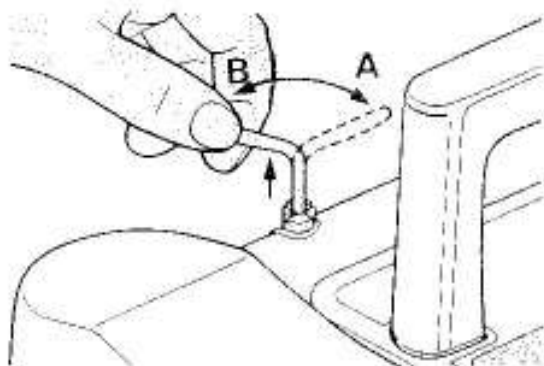

Lift the Row Counter tripper and turn to the side.

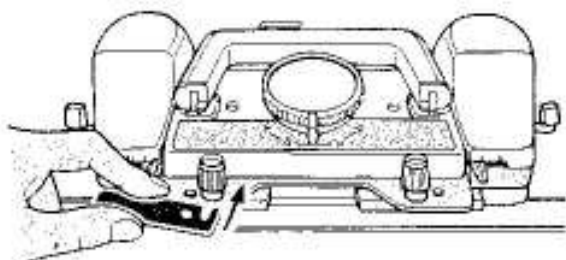

Fasten the carriage to the LEFT side of the needle bed with the lock plate.

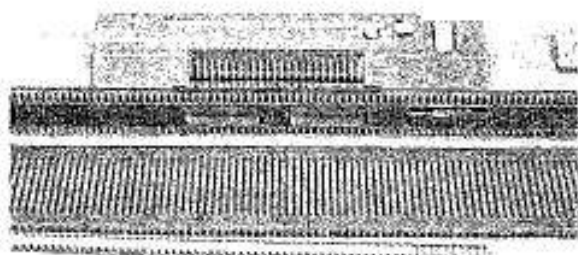

If necessary, remove the card from the pattern panel and set card release to ●.

REPACKING THE MACHINE

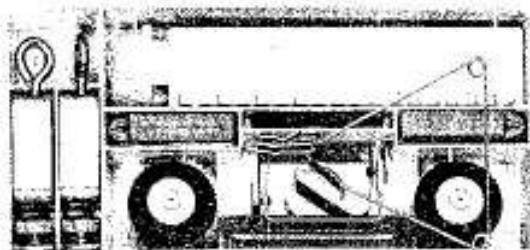

Remove the Yarn Brake and turn DOWN the Take-up Springs. Place it under Spring A in cover.

Place the Sinker Arm Assembly below Spring A. Close Spring A.

If necessary, replace Rib Frame into cover. Insert the Yarn Brake Rod from RIGHT into holder then down into clip.

Remove both Table Clamps from machine, close them and place in Accessory Case. Place all other little accessories into case.



Close the Accessory Case and place it on to needle bed as shown.



Place cover over machine, short side towards the back of machine. Lower the longer end below the machine and close in direction of the arrow.



Close both catch locks on rear cover of machine.

KNITTING

STEP
4



T

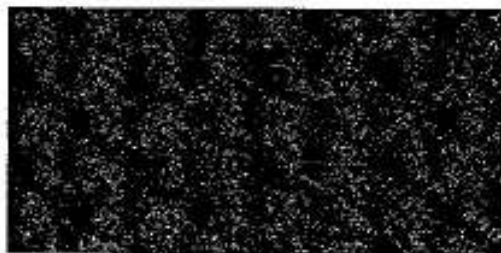

S

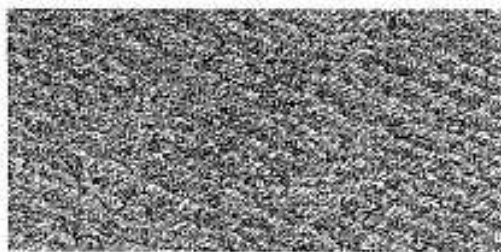

O



L

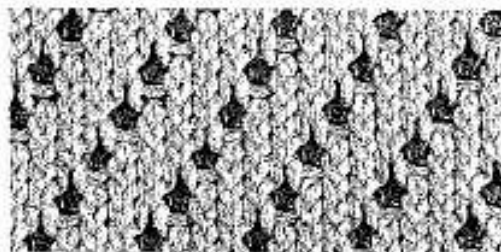

F

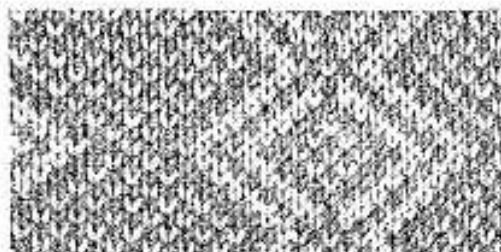

Tuck Stitch patterns	95 - 98
Slip Stitch patterns	99 - 101
Weaving patterns	102 - 107
Lace patterns	108 - 109
Fair Isle patterns	110 - 118

INSERTING THE PUNCH CARD

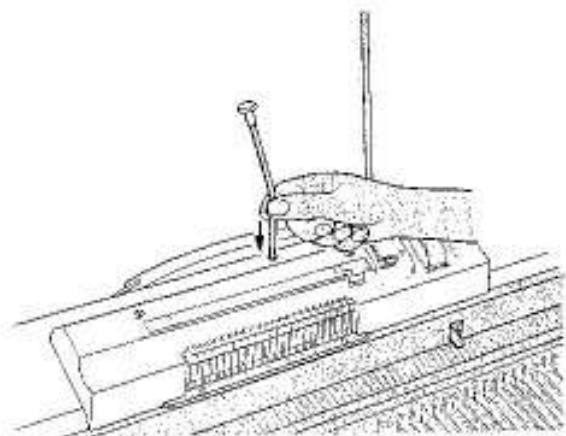

The twenty cards (each a different pattern) are numbered from 1 to 20 and have markings A - B - C and D at the sides.

Usually side A is inserted into the pattern panel, BUT if you wish to knit a pattern upside down as you could do with card 10 - insert C or D at RIGHT side bottom into the pattern panel.

Take the card guide pin from the accessory case and insert it into the little hole at the rear of the pattern panel.

NOTE: WHEN INSERTING A PUNCH CARD MAKE SURE THE CARD IS NEVER CROCKED OR FOLDED.

Set card release to ▼.

Take card 4 and hold A at RIGHT side bottom, insert the card into the pattern panel - adjust the red lines to the front of the card slit.

Turn the feeding dial towards you until the card comes out at the back of the pattern panel. Continue turning the card UP until it is half way through the pattern panel.

Overlap the ends of the card, the end facing you comes on top of the back end. Fit the TWO holes at the edges and join the ends with the little green card clamps as shown.

BE SURE TO ADJUST THE CARD AT THE ENDS BEFORE YOU FIT THE CLAMPS TO THEM.

Turn the feeding dial towards you until row 60 appears at the row indicator.

Set card release to ●.

Row 60 is the pre-setting row, when you slide the carriage to the RIGHT, row 1 will then be at the row indicator and also inside the LEFT side pattern memory of the carriage.

SO ALWAYS HAVE THE LAST ROW OF THE CARD AT THE ROW INDICATOR before knitting the pre-setting row to the RIGHT.

Sometimes the instruction for a pattern may indicate a different number as pre-set row, in this case only you set the card with a different number to the row indicator.

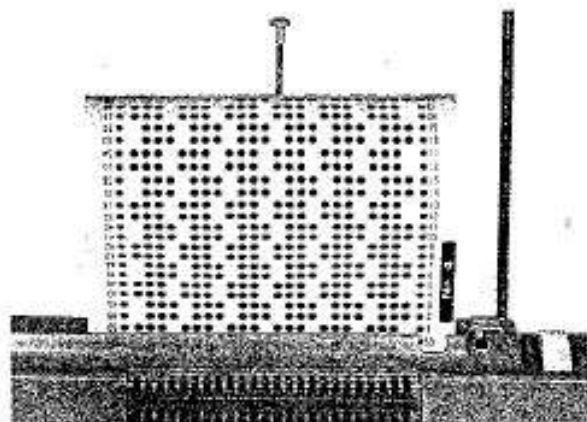
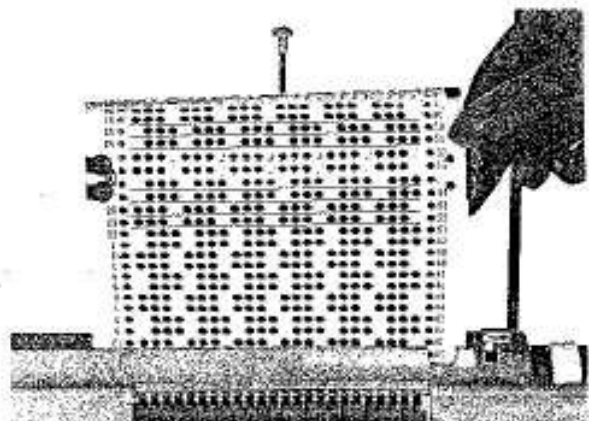
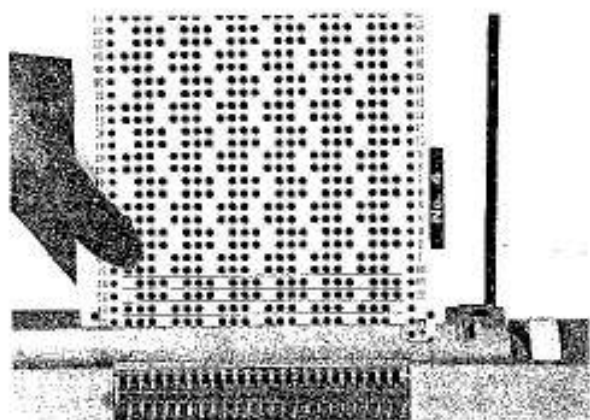

KNITTING – T – TUCK STITCH PATTERNS

In Tuck Stitching, the needles creating the pattern hold the thread rather than knitting the stitches. Alternating colors in Tuck Stitch patterns can give you the effect of Fair Isle patterns.

Colored Tuck Stitch patterns are knitted as the normal Tuck patterns, ONLY you change the colours in the Yarn Feeder 1. TWO colors can be threaded through the Yarn Brake, if you wish to use a third color, it hangs down from the side of the knitting.

When col. 3 is to be knitted, thread it in Feeder 1 and hold it on top of the carriage as for knitting in the Nylon Cord. Hold col. 3 with your LEFT hand and with your RIGHT hand move the carriage across the knitting. Let the yarn slide through your fingers as it is needed to make the stitches. PULL UP the yarn at the beginning of each row to avoid it to get entangled around the brush wheels, just until the carriage has made contact with the needles in knitting position.

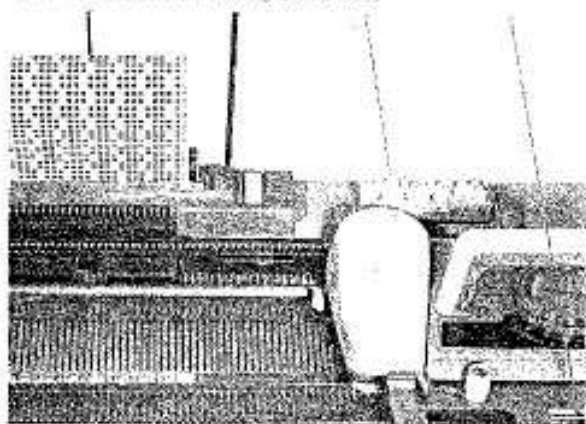

Card 1 – A, Col, 1 - green, 1 Pat. = 2 sts, 2 rows.

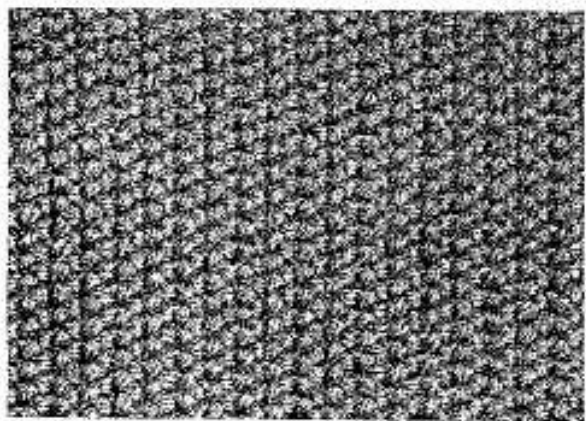

Card 3 – A, Col, 1 - red, 1 Pat. = 4 sts, 8 rows.

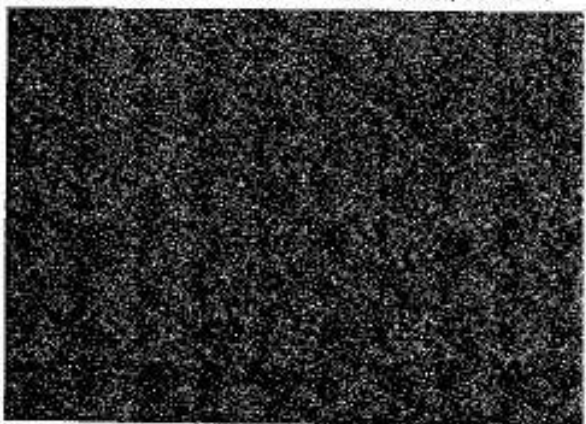

Card 4 is inserted and card release set to ●.
Make an open edge cast-on over 60 needles and knit 6 rows, carriage at LEFT, Row Counter shows 7. Set card release to ▼ and knit the pre-set row to the RIGHT, 60 has disappeared from the row indicator and is replaced by 1. This row of pattern is now pre-set in the LEFT side pattern memory. Side Levers are set BACK - Front Levers to II, Arm Levers are set to ▼.

NOTE: When doing partial knitting, the Front Levers are set to I.

Leave card release to ▼, set Cam Lever to T. Insert claws through the edges of the knitting. Knit 20 rows and move the claws up and insert them through the last rows.

Card 2 – A, Col, 1 - blue, 1 Pat. = 4 sts, 4 rows.
This pattern is knitted using a Tension 2 to 3 Tension Numbers TIGHTER than used for plain knitting.

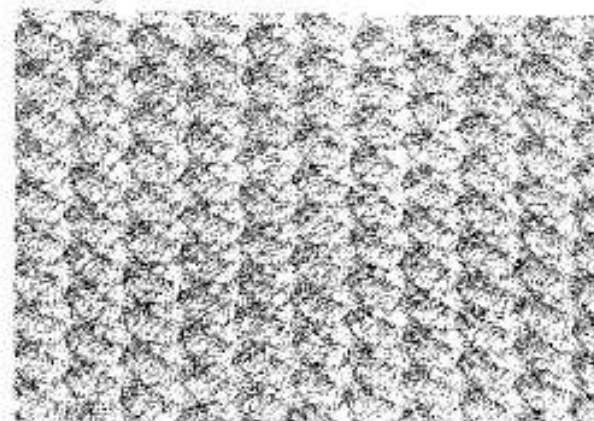

Card 4 – A, Col, 1 - green, 1 Pat. = 4 sts, 4 rows.

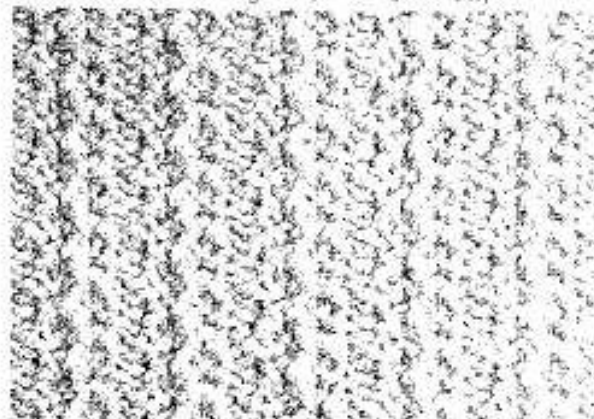

KNITTING— T — TUCK STITCH PATTERNS

Card 6 — A. Col. 1 - red. 1 Pat. = 6 sts, 16 rows.



Card 7 — A. Col. 1 - blue. 1 Pat. = 2 sts, 4 rows.

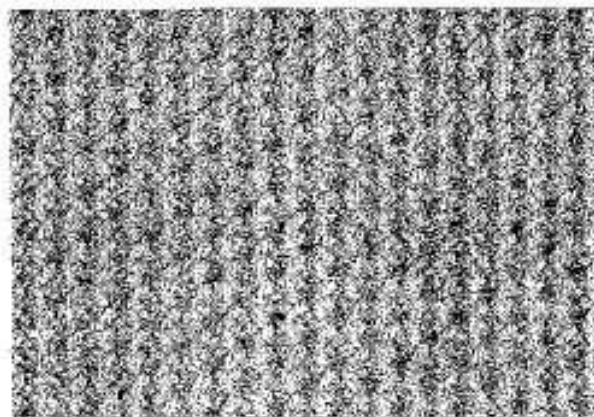

Card 8 — A. Col. 1 - green. 1 Pat. = 3 sts, 18 rows.

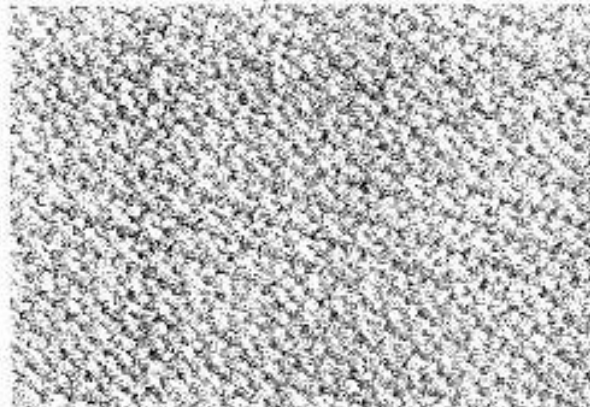

Card 9 — A. Col. 1 - grey. 1 Pat. = 12 sts, 24 rows.

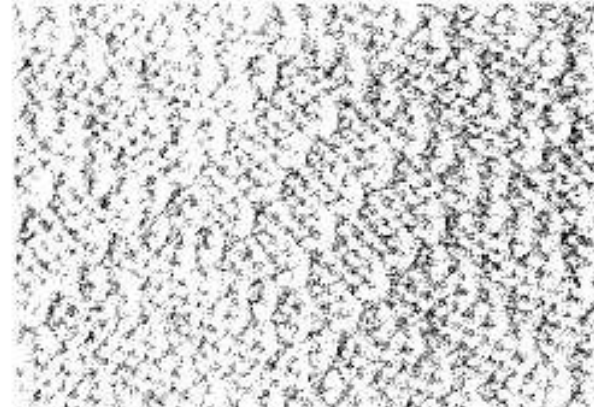

Card 10 — A. Col. 1 - yellow. 1 Pat. = 12 sts, 20 rows.

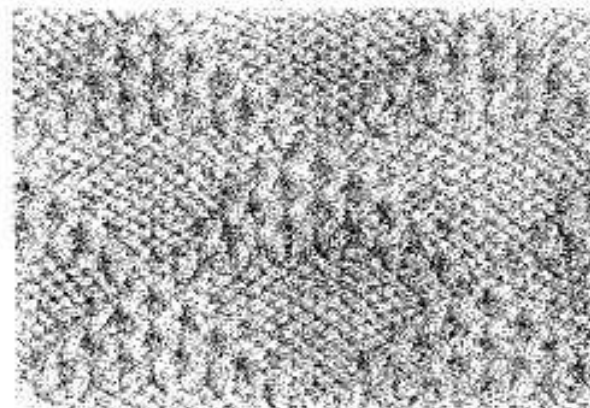

Card 11 — A. Col. 1 - green. 1 Pat. = 8 sts, 24 rows.

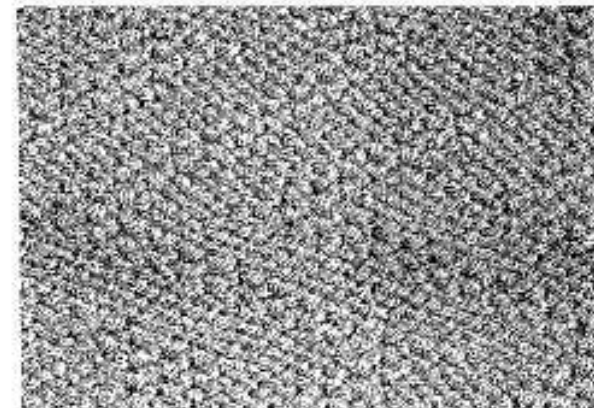

Card 12 — A. Col. 1 - red. 1 Pat. = 12 sts, 24 rows.



Card 18 — A. Col. 1 - blue. 1 Pat. = 24 sts, 44 rows.

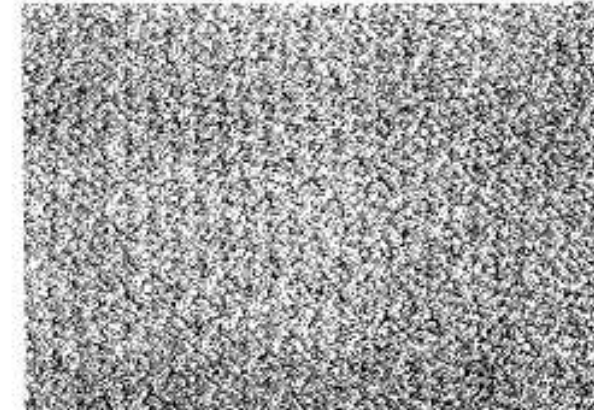

KNITTING – T – TUCK STITCH PATTERNS

* Means repeat the instructions from this point.

Card 19 – A, Col. 1 - green; 1 Pat.=24 sts, 24 rs.

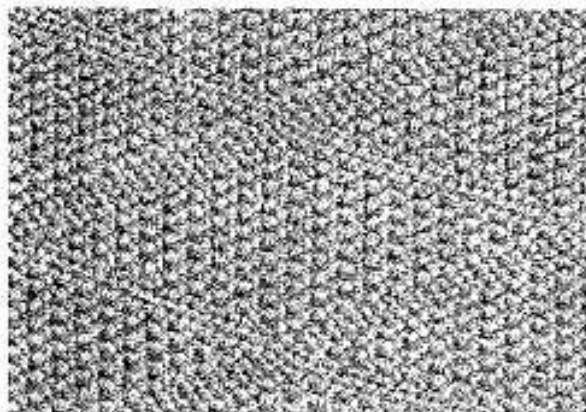

Card 4 – A, VARIATION 1, Col. 1 - grey.
1 Pat. = 4 sts, 4 rows.

After pre-set row 60 - 1 – card release to ●.

* Knit 3 rows, Cam Lever to T.

Knit 1 row, Cam Lever to center O.

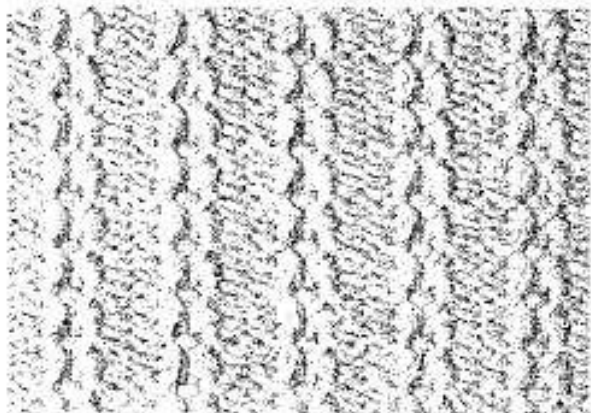

Card 6 – A, VARIATION 1, Col. 1 - green.
1 Pat. = 8 sts, 4 rows.

After pre-set row 48 – 1, set card release to ●.

* Knit 3 rows Cam Lever to T.

Knit 1 row Cam Lever to center O.

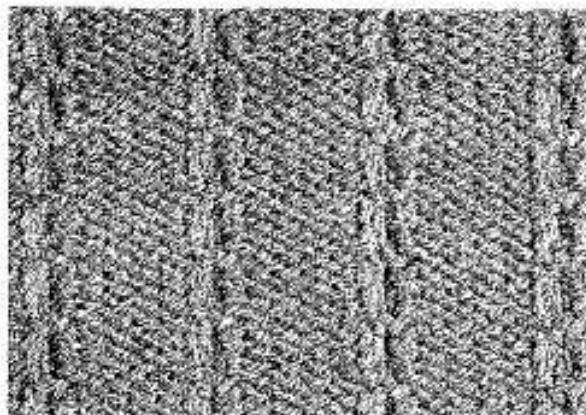

Card 6 – A, VARIATION 2, Col. 1 - yellow.
1 Pat. = 6 sts, 12 rows.

After pre-set row 48 – 1, card release to ●.

Knit 5 rows Cam Lever to T.

* Turn card 8 rows UP - card release to ●, knit 6 rs.

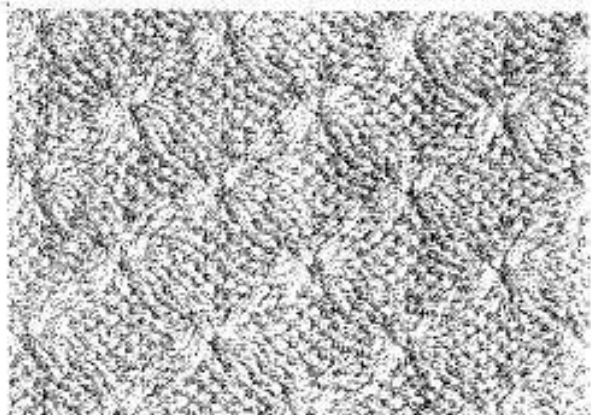

Card 10 – A, VARIATION 1, Col. 1 - blue.
1 Pat. = 12 sts, 28 rows.

After pre-set row 60 – 1,

* Card release ▼, Cam Lever T, knit 10 rows

Card release ●, Cam Lever O, knit 4 rows.

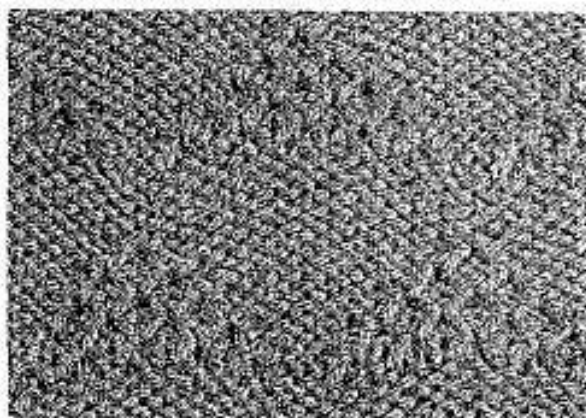

Card 12 – A, VARIATION 1, Col. 1 - yellow.
1 Pat. = 12 sts, 12 rows.

After pre-set row 48 – 1,

* Knit to 12 – turn card BACK to 48.

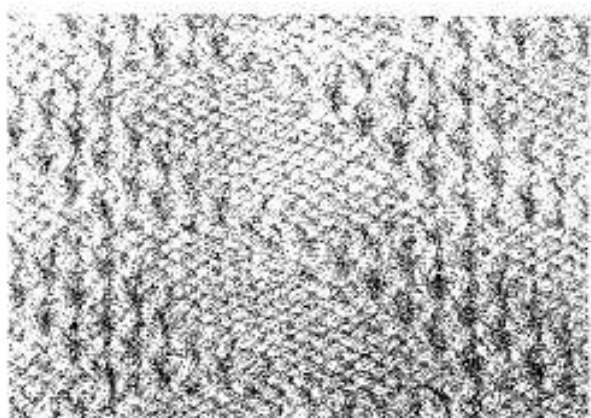

TUCK PATTERNS USING SEVERAL COLOURS

* Means repeat the instructions from this point.

Card 3 – A, Col. 1 - red, Col. 2 - white,
VARIATION 1, 1 Pat. = 4 sts, 8 rows.

After pre-set row 56 – 1,

- * Knit 4 rows col. 1 in Feeder 1.
- Knit 4 rows col. 2 in Feeder 1.

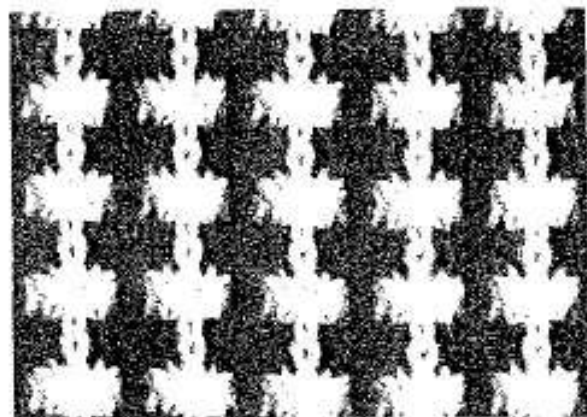

Card 3 – A, Col. 1 - brown, Col. 2 - pink, Col. 3 - white,
VARIATION 2, 1 Pat. = 4 sts, 12 rows.

After pre-set row 56 – 1,

- * Knit 4 rows col. 1 in Feeder 1.
- Knit 4 rows col. 2 in Feeder 1.
- Knit 4 rows col. 3 in Feeder 1.

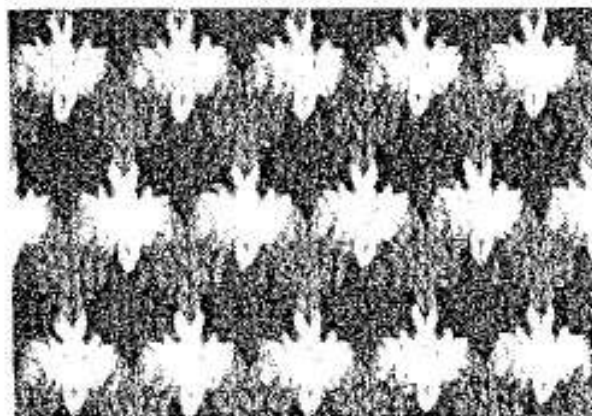

Card 3 – A, Col. 1 - white, Col. 2 - green,
VARIATION 3, 1 Pat. = 4 sts, 12 rows.

After pre-set row 56 – 1,

- * Knit 4 rows col. 2, Cam Lever T, card release ▼.
- Card release ●, Cam Lever 0, knit 2 rows col. 1.

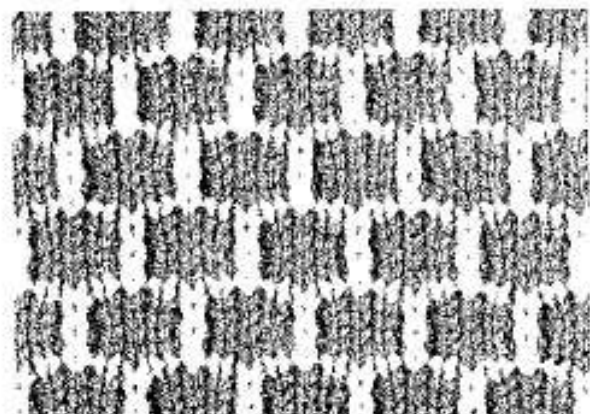

Card 6 – A, Col. 1 - white, Col. 2 - blue,
VARIATION 3, 1 Pat. = 6 sts, 16 rows.

After pre-set row 48 – 1,

- * Knit 4 rows col. 1 in Feeder 1.
- Knit 4 rows col. 2 in Feeder 1.

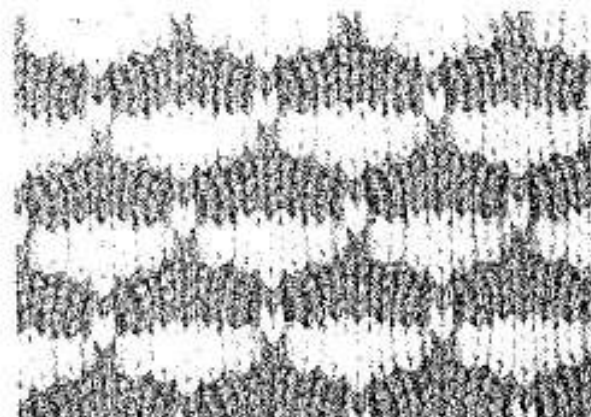

Card 6 – A, Col. 1 - yellow, Col. 2 - green,
VARIATION 4, 1 Pat. = 6 sts, 16 rows.

After pre-set row 48 – 1,

- * Knit 8 rows col. 1 in Feeder 1.
- Knit 8 rows col. 2 in Feeder 1.

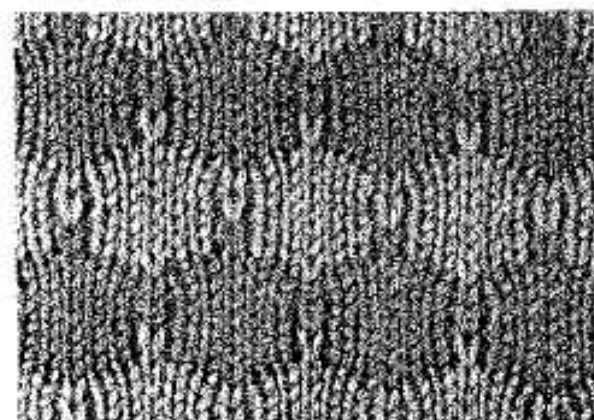

Card 12 – A, Col. 1 - green, Col. 2 - yellow,
VARIATION 2, 1 Pat. = 12 sts, 24 rows.

After pre-set row 48 – 1,

- * Knit 2 rows col. 1 in Feeder 1.
- Knit 2 rows col. 2 in Feeder 1.

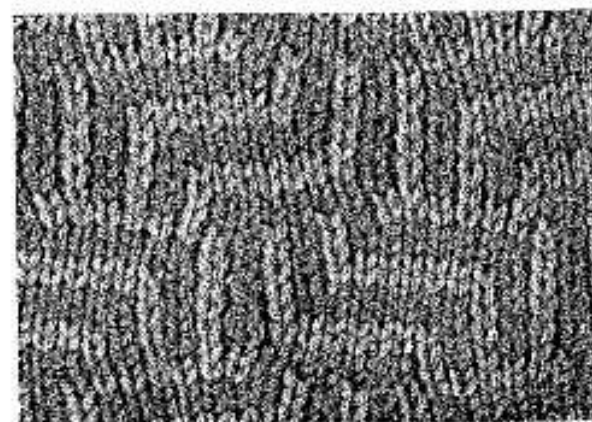

KNITTING – S – STITCH PATTERNS

Slip stitch patterns are formed by the yarn thread which remains in front of the fabric instead of being knitted.

Slip stitch patterns are knitted using a Tension at LEAST 1 or 2 Tension Numbers HIGHER (LOOSER) than for plain knitting, as the thread cause the fabric to close up.

For example, if Tension 6 is used for plain knitting, you need to use Tension 7 or 8 when doing Slip stitch patterns.

Make an open edge cast-on over 60 needles and knit 6 rows, the carriage is at LEFT and the Row Counter shows 7. Set card release to ▼.

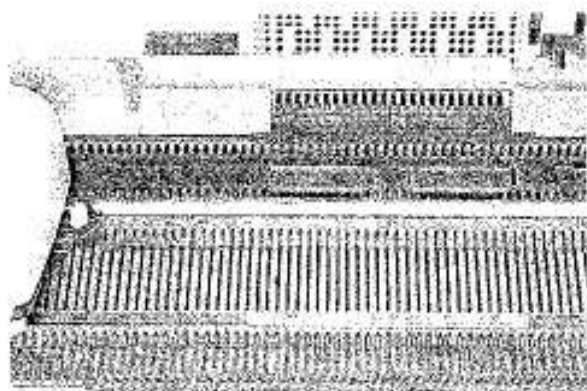

Take card 3 and insert it - A at RIGHT bottom- into the pattern panel.

Secure card ends with clamps.

Turn feeding dial until 56 is at row indicator.

Leave card release to ▼, set Front Levers to I.

Arm Levers are set to O.

Knit the pre-setting row 56 towards the RIGHT.

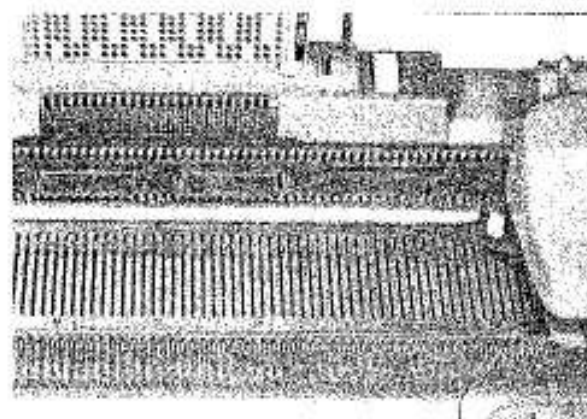

The row indicator shows 1 and Row Counter 8.
Set Cam Lever to S and Side Levers BACK,
Insert claws through edges of knitting.

Knit 20 rows - remove the claws from the edge and insert them through the top rows of the knitting.

Continue knitting - always bringing the claws up after a while.

NOTE: When doing partial knitting - have the Front Levers set to I.

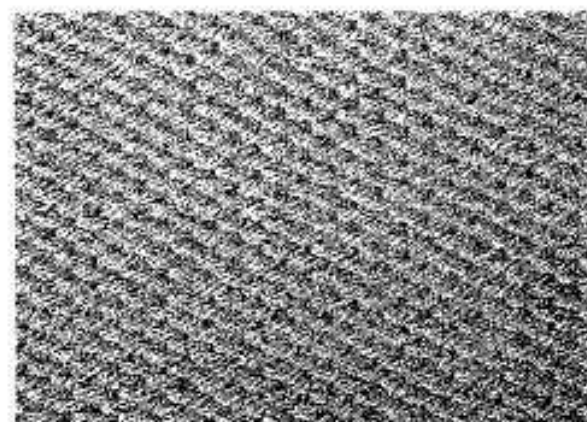

Cord 1 - A, Col. 1 - green. 1 Pat. = 2 sts, 2 rows.

KNITTING – S – STITCH PATTERNS

Card 2 – A, Col. 1 - red, 1 Pat. = 4 sts, 4 rows,

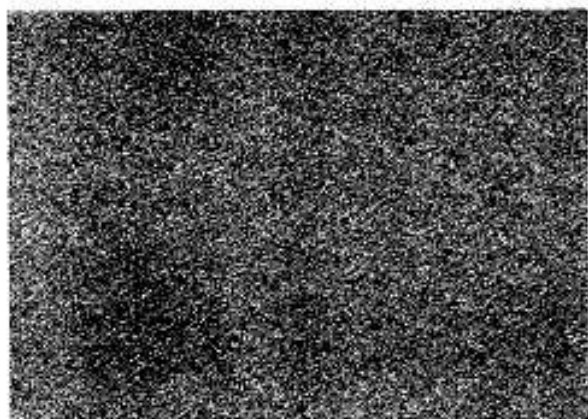

Card 3 – A, Col. 1 - yellow, 1 Pat. = 4 sts, 8 rows,

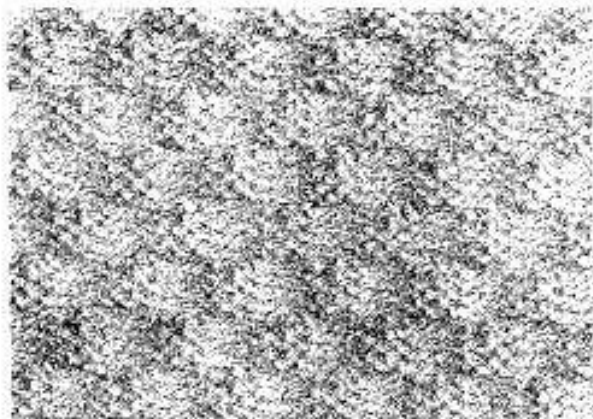

Card 7 – A, Col. 1 - blue, 1 Pat. = 2 sts, 4 rows,

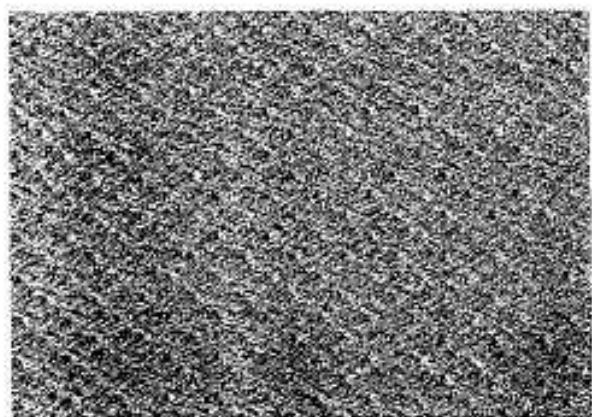

Card 8 – A, Col. 1 - pink, 1 Pat. = 3 sts, 18 rows,

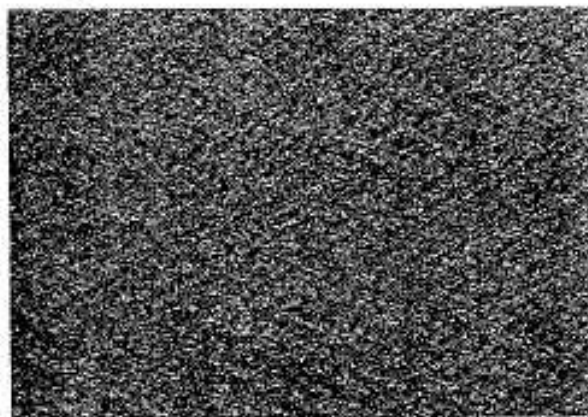

Card 9 – A, Col. 1 - grey, 1 Pat. = 12 sts, 24 rows,

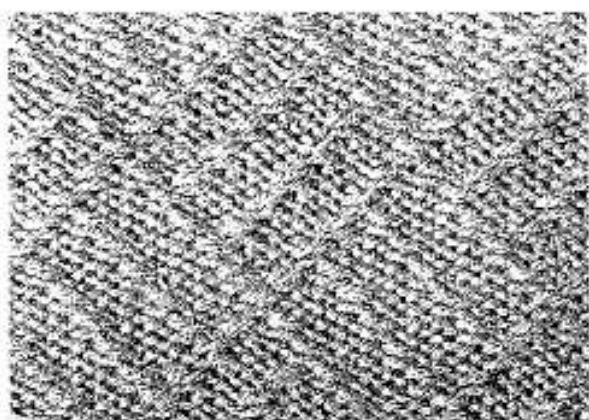

Card 10 – A, Col. 1 - red, 1 Pat. = 12 sts, 20 rows,

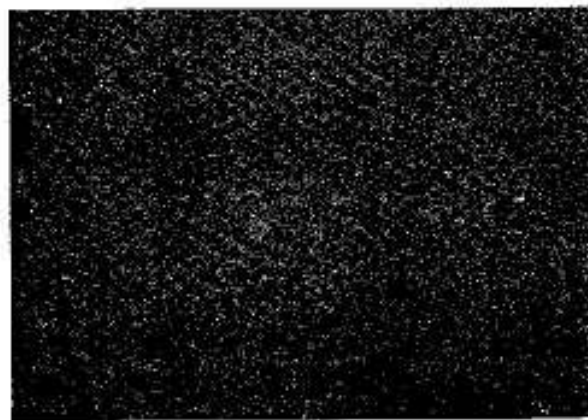

KNITTING — S — STITCH PATTERNS

Card 11 — A. Col. 1 - blue, 1 Pat. = 8 sts, 24 rows.

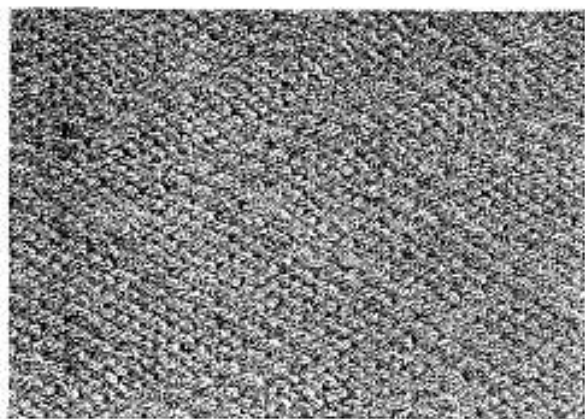

Card 12 — A. Col. 1 - red, 1 Pat. = 12 sts, 24 rows.

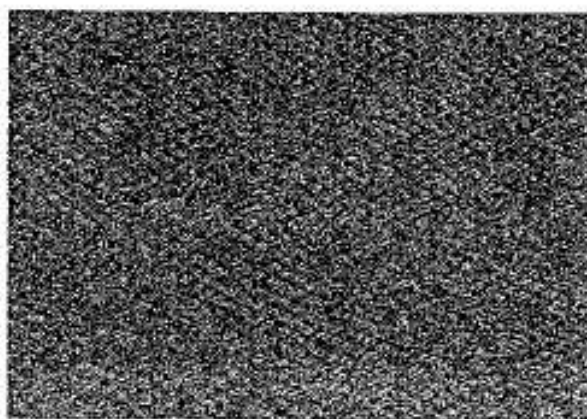

Card 14 — A. Col. 1 - blue, 1 Pat. = 24 sts, 12 rows.

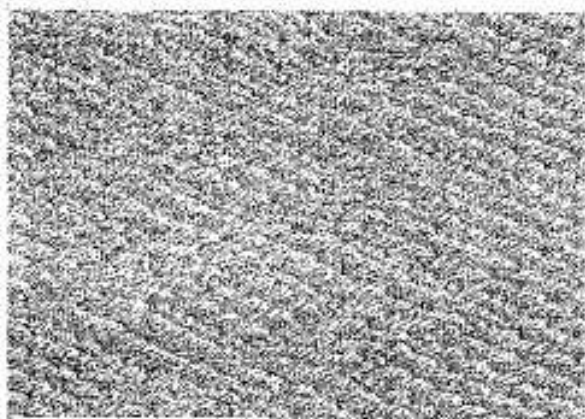

Card 16 — A. Col. 1 - green, 1 Pat. = 24 sts, 30 rows.

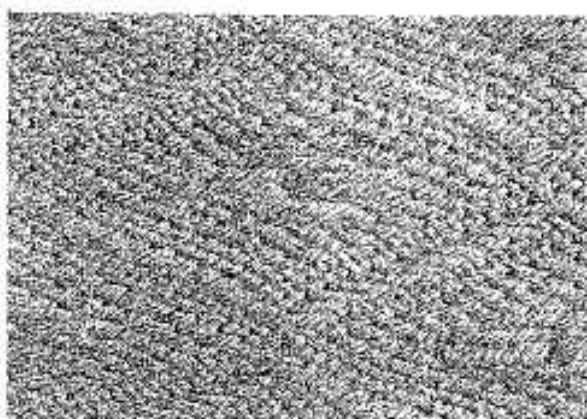

Card 18 — A. Col. 1 - red, 1 Pat. = 24 sts, 44 rows.



Card 19 — A. Col. 1 - blue, 1 Pat. = 24 sts, 24 rows.

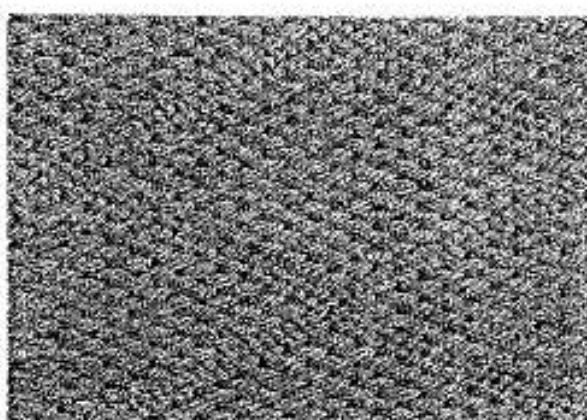

KNITTING WEAVING PATTERNS

Weaving patterns are one of the fabulous features of your knitting machine. Every kind of exciting yarn can be used to make fashionable weaving fabrics.

As weaving thread you can use any wool or yarn, but as knitting yarn (backing yarn) you should use a thin to medium quality yarn up to Tension 7. If you use a thicker yarn for knitting, the fabric could be too hard and heavy.

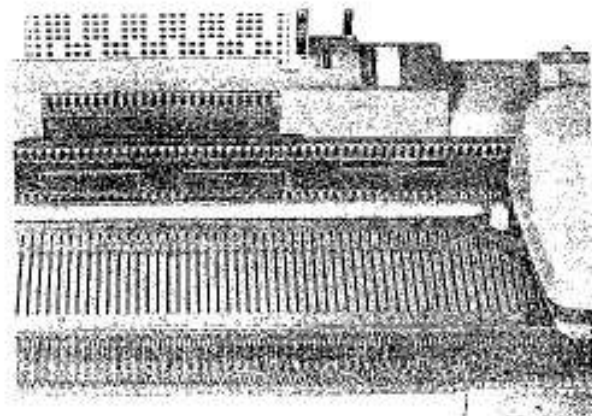

Make an open edge cast-on over 60 needles and knit 6 rows, the carriage is at LEFT and the Row Counter shows 7.
Set card release to ▼ - Front Levers to II,
Arm Levers are set to O.
Insert card 3 - A at RIGHT side bottom - into the pattern panel and secure card ends with clamps.
Turn card until 56 is at the row indicator.
Leave card release to ▼.
Knit the pre-setting row 56 to the RIGHT, Row indicator shows 1 and Row Counter 8.
Set Side Levers BACK.
Insert the claws through edges of fabric.



From the accessory case take the Weaving Brush.

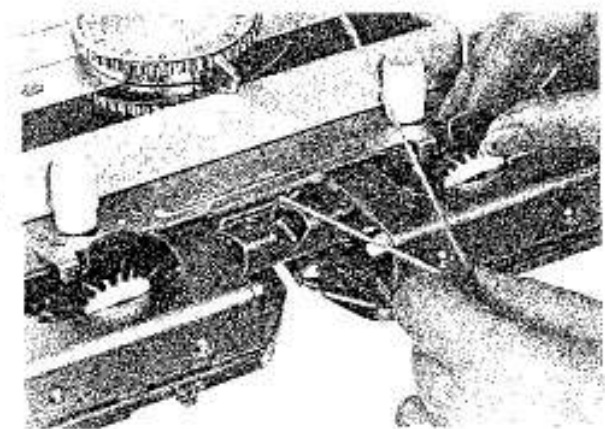

Turn BOTH thumb screws on the Sinker Arm until they are wide open.
With one hand pull the knitting yarn towards you and with the other slide the Weaving Brush under the thumb screws - BEHIND the knitting yarn.

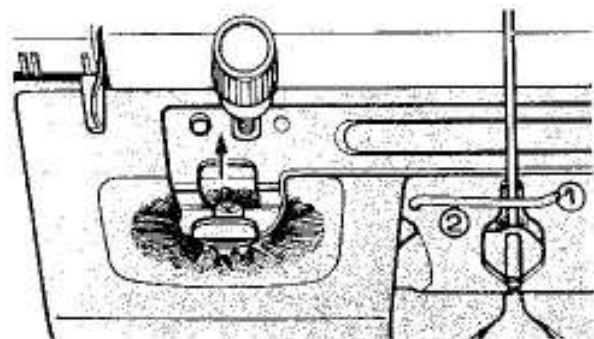

This diagram shows you exactly how to fix the Weaving Brush. The knitting yarn must be in front of the Brush - if you fasten the Weaving Brush in front of the knitting yarn it comes under the Weaving Brush and you will NOT be able to knit.

KNITTING WEAVING PATTERNS

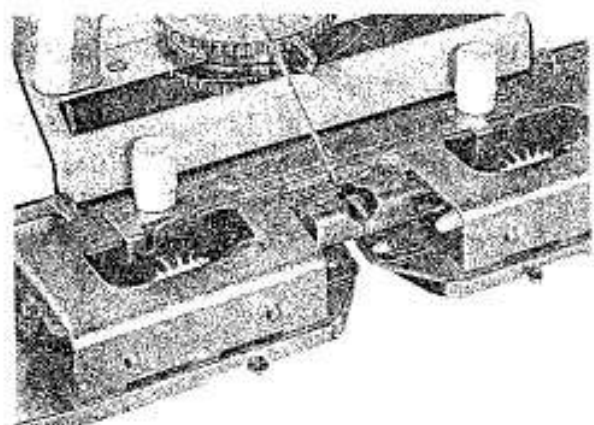

This is the Weaving Brush fitted correctly on to the Sinker Arm, Fasten the two thumb screws.

Take any thick yarn as substitution for weaving thread and thread it through all LEFT side feed points of the Yarn Brake, Fasten the end on to the RIGHT side Table Clamp.

The weaving thread must come down from the Yarn Brake in FRONT of the knitting thread.

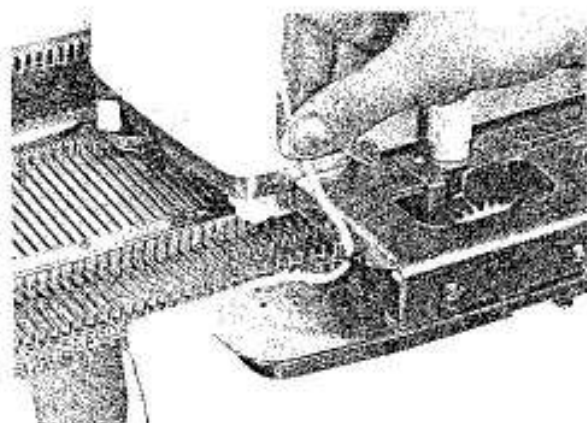

Take the weaving thread up at the LEFT side of the carriage and then INSIDE the Weaving Guide, Pull up the thread a little while moving the carriage slightly to the LEFT.

At RIGHT, bring the end needle to D position, Knit to the LEFT.

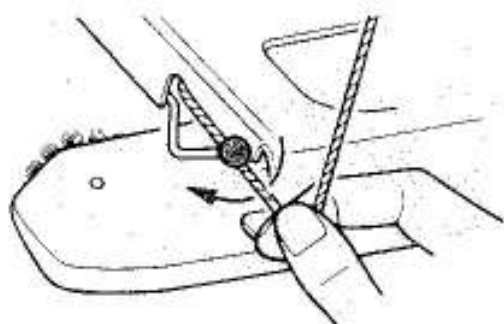

At LEFT, pull the thread towards you - out of the Weaving Guide and towards the BACK.

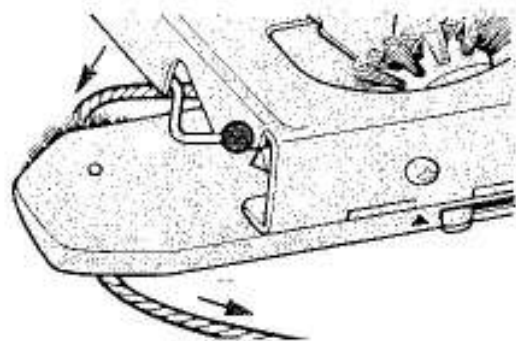

Move the thread backwards - underneath the Sinker Arm and after passing it under the carriage pull it towards the RIGHT.

KNITTING WEAVING PATTERNS

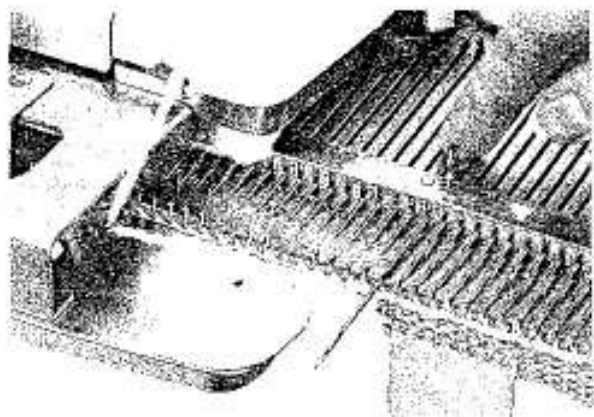

At the RIGHT side of the carriage - bring the thread INSIDE the Weaving Guide.

The picture shows you the position of the weaving thread on the RIGHT side of the carriage.

Bring the LEFT end needle to D position and knit to the RIGHT.

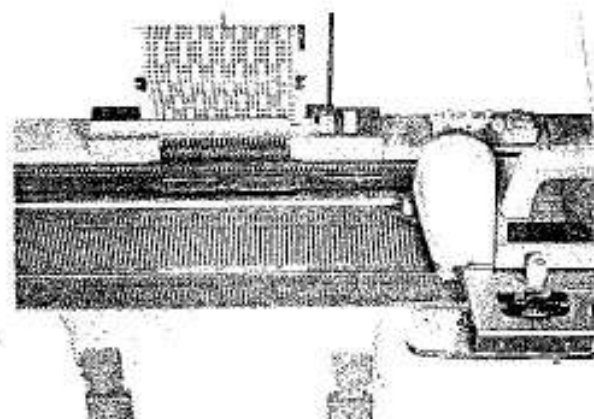

Continue weaving, after a every row remove the thread from one side of the carriage to the other side and bring it into the Weaving Guide, and after a while move the claws up.

NOTE: When doing partial knitting, have the Front Levers set to 1, but then bring the end needle to C position only.

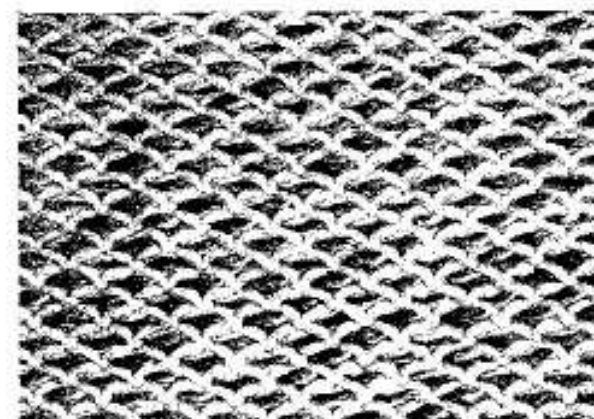

Card 1 - A, Col. 1 - white. Thread tweed.
1 Pat. = 2 sts, 2 rows.

Card 2 - A, Col. 1 - grey. Thread red.
1 Pat. = 4 sts, 4 rows.

Card 3 - A, Col. 1 - brown. Thread orange.
1 Pat. = 4 sts, 8 rows.

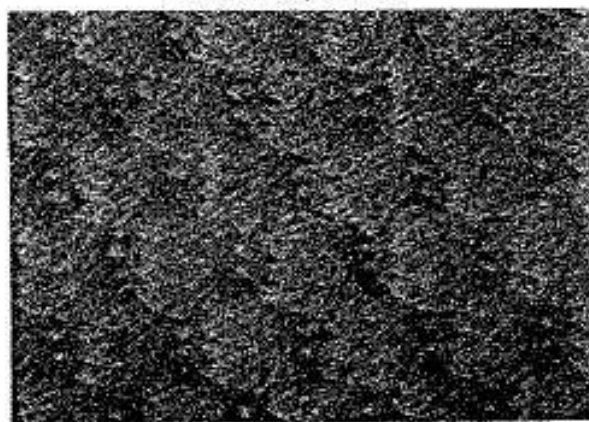
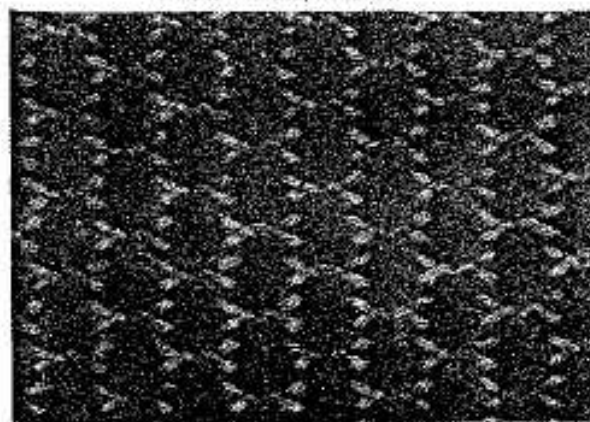

KNITTING WEAVING PATTERNS

Card 4 — A, Col. 1 - green, Thread yellow,
1 Pat. = 4 sts, 4 rows.

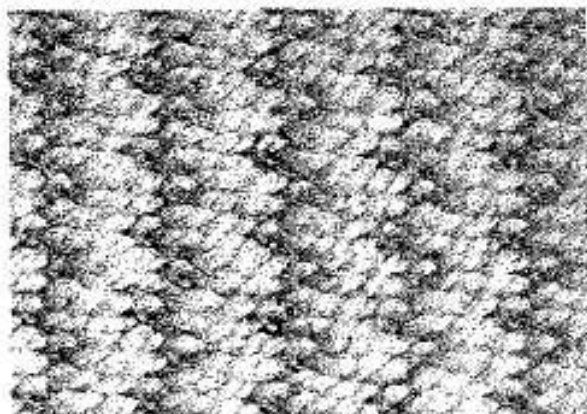

Card 5 — A, Col. 1 - red, Thread white,
1 Pat. = 4 sts, 8 rows.

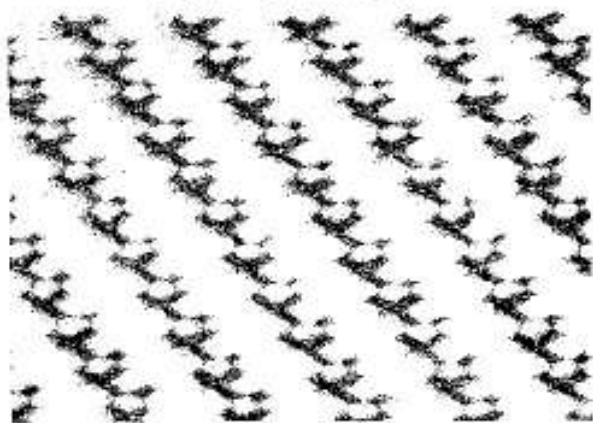

Card 7 — A, Col. 1 - white, Thread blue,
1 Pat. = 2 sts, 4 rows.

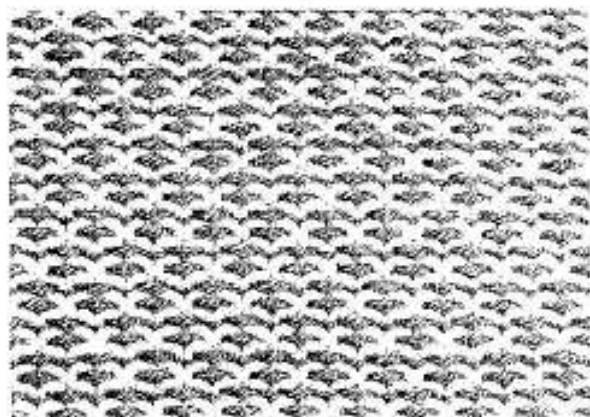

Card 8 — A, Col. 1 - white, Thread red,
1 Pat. = 3 sts, 18 rows.

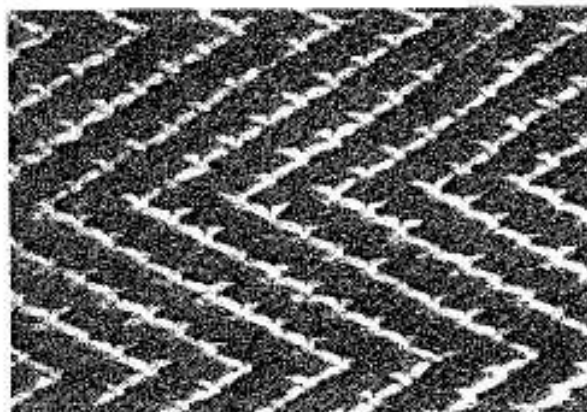

Card 9 — A, Col. 1 - white, Thread blue,
1 Pat. = 12 sts, 24 rows.

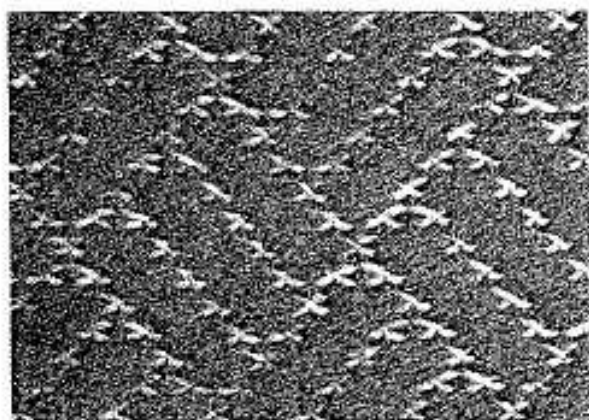

Card 11 — A, Col. 1 - blue, Thread white,
1 Pat. = 8 sts, 24 rows.

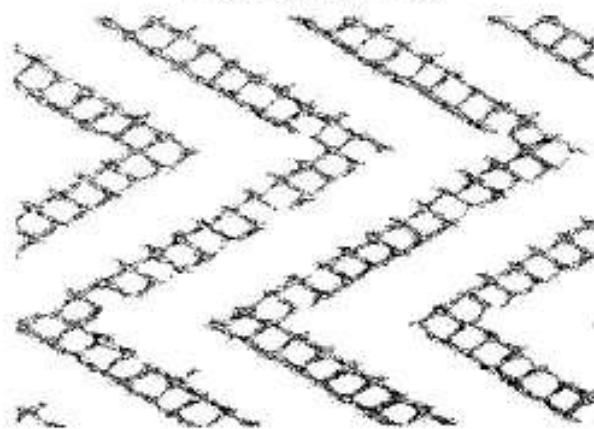

KNITTING WEAVING PATTERNS

* Means repeat the instructions from this point.

Card 14 – A, Col, 1 - white, Thread green,
1 Pat. = 24 sts, 12 rows.

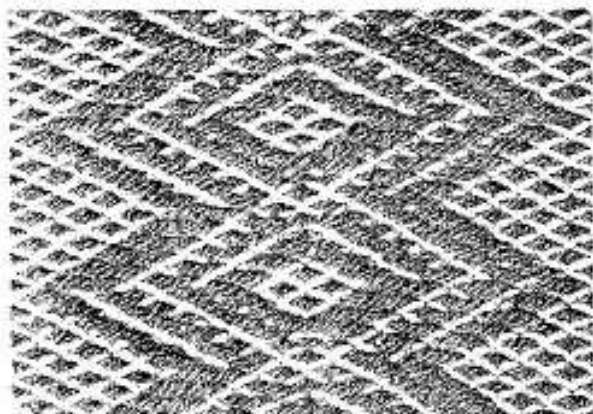

Card 16 – A, Col, 1 - white, Thread coloured,
1 Pat. = 24 sts, 30 rows.

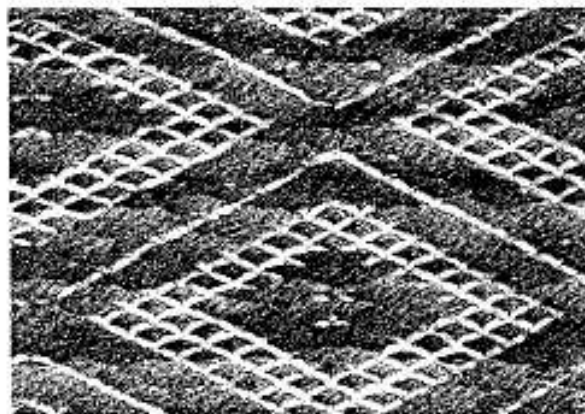

Card 18 – A, Col, 1 - white, Thread blue,
1 Pat. = 24 sts, 44 rows.

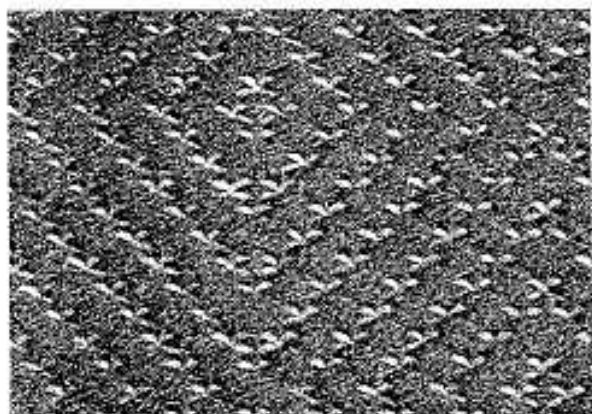

Card 19 – A, Col, 1 - white, Thread red,
1 Pat. = 24 sts, 24 rows.

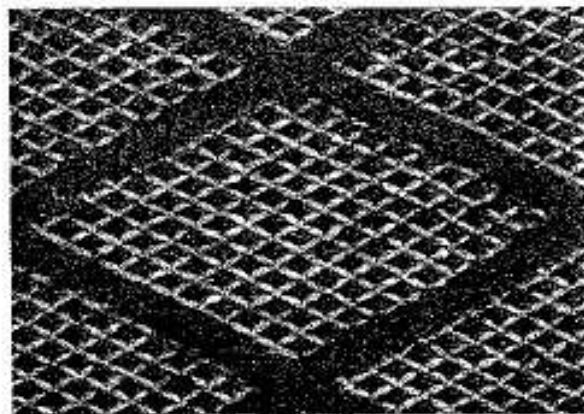

Card 1 – A, Col, 1 - yellow, Thread green,
VARIATION 1, 1 Pat. = 2 sts, 1 row.
After pre-set row 60 – 1,
* Continue weaving Card release to ● .

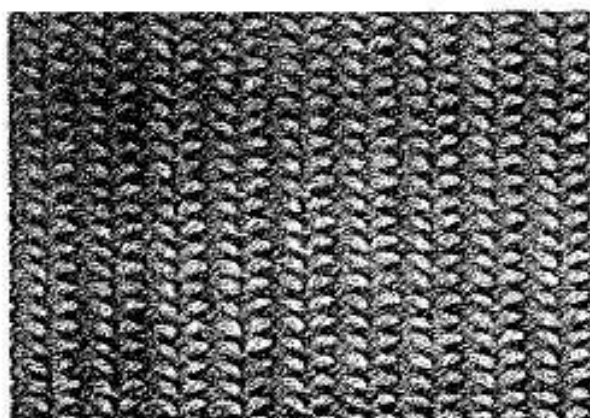

Card 3 – A, Col, 1 - white, Thread coloured,
VARIATION 4, 1 Pat. = 4 sts, 4 rows.
Same as for card, but the coloured yarn gives you
a new pattern effect.

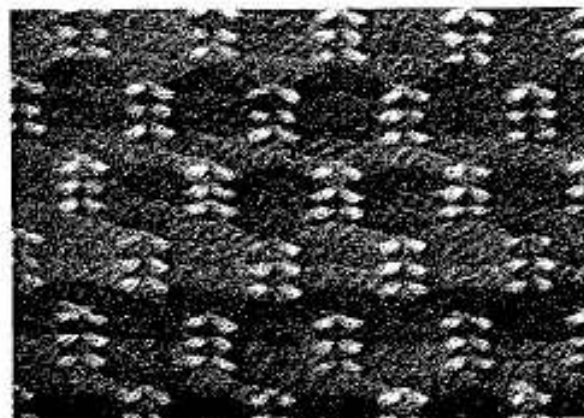

KNITTING WEAVING PATTERNS

* Means repeat the instructions from this point.

Card 3 – A, Col. 1 - black, Thread tweed.
 VARIATION 5. 1 Pat. = 4 sts, 1 row.
 After pre-set row 56 – 1,
 * Continue weaving with card release to ●.

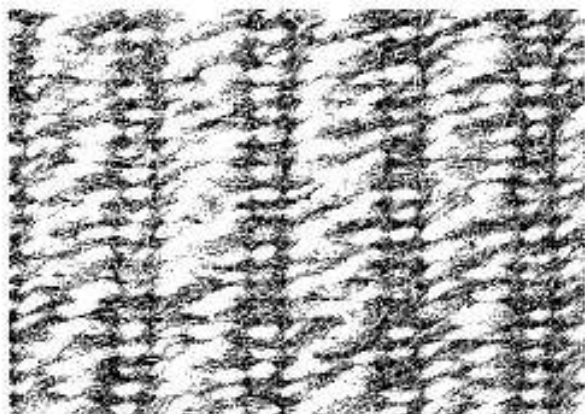

Card 9 – A, Col. 1 - white, Thread green.
 VARIATION 1. 1 Pat. = 12 sts, 30 rows.
 After pre-set row 48 – 1,
 * Card release to ● - weave 6 rows,
 Card release to ▼ - weave 12 rows.

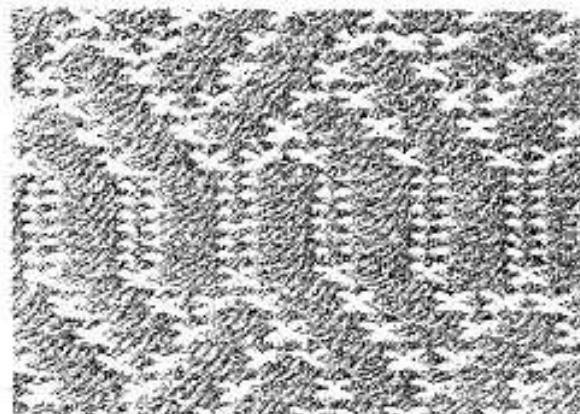

Card 11 – A, Col. 1 - green, Thread yellow.
 VARIATION 1. 1 Pat. = 8 sts, 10 rows.
 After pre-set row 7 – 8, card release to ▼.
 Weave 9 rows – card at 17.
 * Set card to 7 – weave 10 rows.



Card 11 – A, Col. 1 - grey, Thread red.
 VARIATION 2. 1 Pat. = 8 sts, 48 rows.
 After pre-set row 48 – 1,
 * Weave 4 rows Card release to ▼,
 Weave 4 rows Card release to ●.

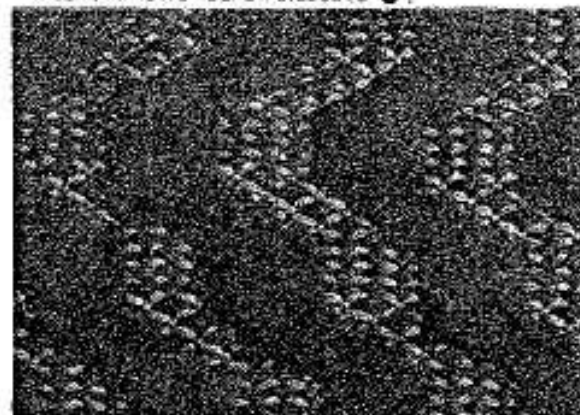

Card 14 – A, Col. 1 - green, Thread orange.
 VARIATION 1. 1 Pat. = 24 sts, 24 rows.
 After pre-set row 60 – 1,
 * Weave 2 rows Card release to ▼,
 Weave 2 rows Card release to ●.



Card 16 – A, Col. 1 - white, Thread red.
 VARIATION 1. 1 Pat. = 24 sts, 60 rows.
 After pre-set row 60 – 1,
 * Weave 2 rows Card release to ▼,
 Weave 2 rows Card release to ●.



KNITTING – L – LACE PATTERNS

Punch-Lace knitting is a unique feature of your knitting machine. By knitting a transparent nylon thread at the same time as your normal knitting yarn - beautiful lace can be made.

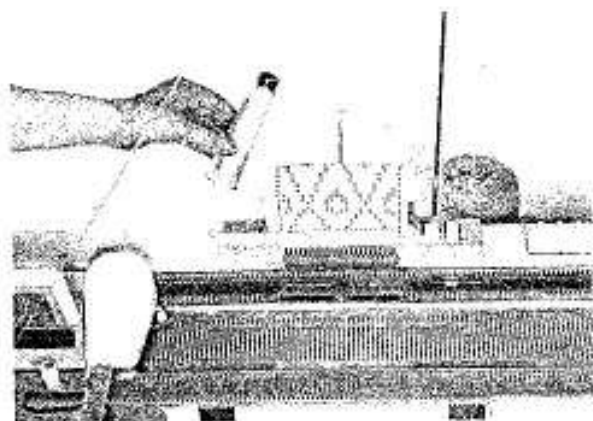

Make an open edge cast-on over 60 needles and knit 6 rows, carriage at LEFT and Row Counter shows 7.

Set card release to ▼.

Take card 15 and insert it - A at RIGHT bottom - into the pattern panel. Secure ends with clamps. Turn card until 48 shows at row indicator, leave card release to ▼.

Set Side Levers BACK - Front Levers to L.

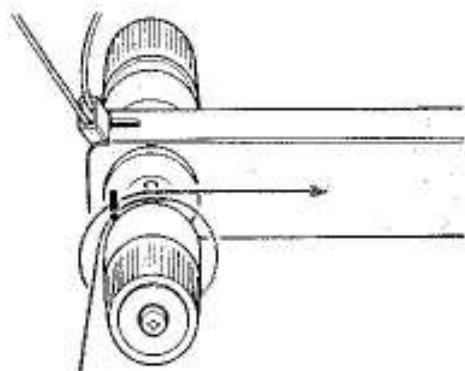

Take a roll of transparent nylon thread and thread it through all LEFT side feed points of Yarn Brake.

BUT – TURN IT ONCE COMPLETELY AROUND THE YARN BRAKE CENTER – otherwise the nylon thread will have NO TENSION. Adjust Yarn Brake. Tension for nylon thread to 5.

The Tension Dial of the carriage is ALWAYS set to suit the yarn knitted through Feeder 1. Insert the CLAWS THROUGH THE EDGES of the knitting.

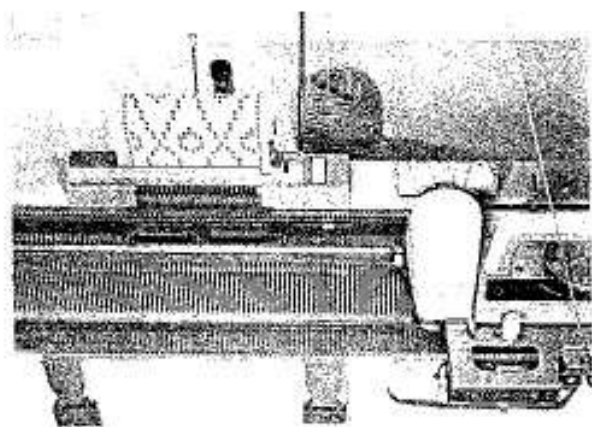

To secure the nylon thread properly, knit it in the pre-setting row together with the yarn in Feeder 1, so, thread the nylon thread through Feeder 1.

Knit the pre-setting row to the RIGHT.

Row indicator shows 1 and Row Counter 8.

CAREFULLY remove the nylon thread from the Feeder 1 and thread it through Feeder 2 - make sure it is at the LEFT of the Feeder guide pin.

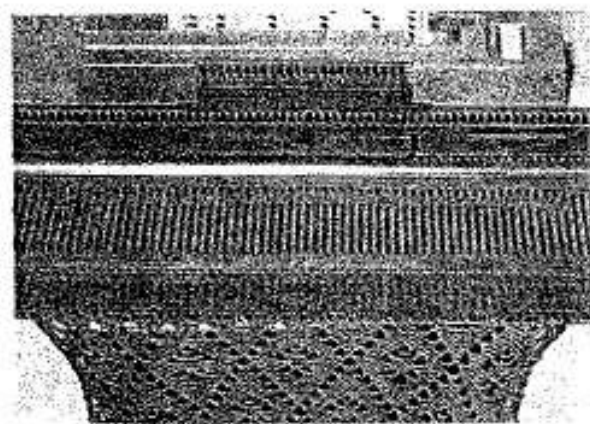

Set Cam Lever to L - Arm Levers set to ▼.

Tension Dial is set to suit the yarn in Feeder 1.

NOT moving the carriage TOO FAST, knit about 40 rows of pattern, insert the claws through the last rows of pattern.

KNITTING — L — LACE PATTERNS

Card 1 — A, Col. 1 - yellow. 1 Pat. = 2 sts, 2 rows.

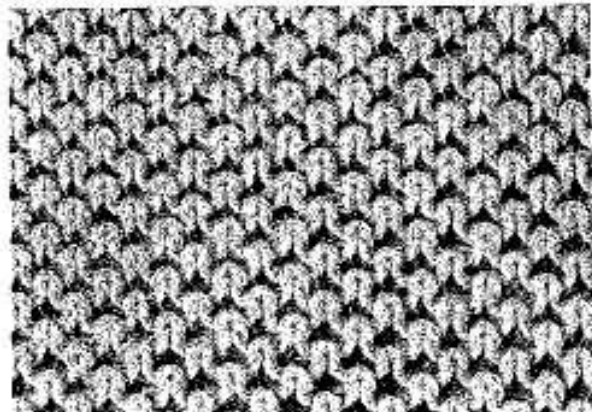

Card 2 — A, Col. 1 - green. 1 Pat. = 4 sts, 4 rows.

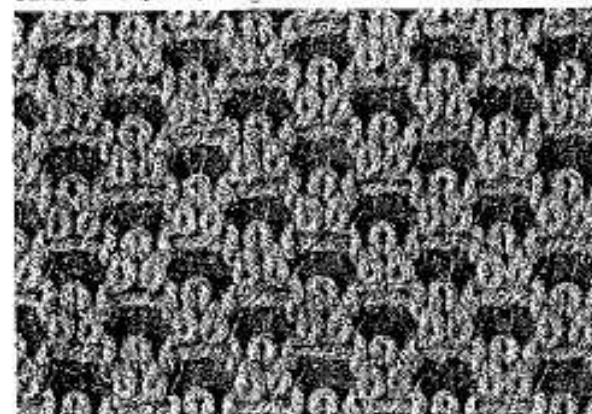

Card 7 — A, Col. 1 - white. 1 Pat. = 2 sts, 4 rows.

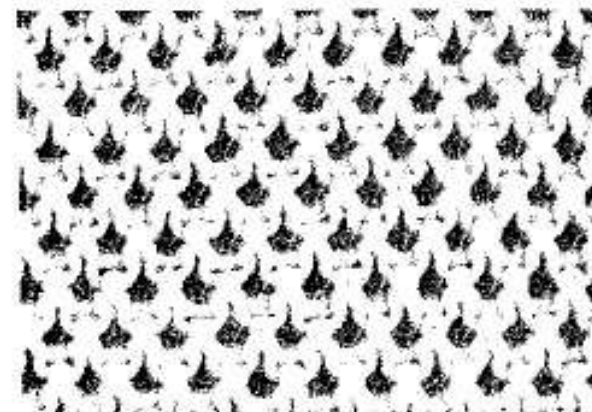

Card 17 — A, Col. 1 - red. 1 Pat. = 24 sts, 30 rows.

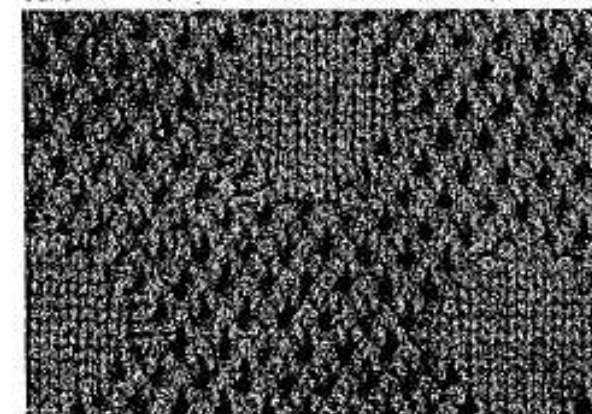

Card 5 — A, Col. 1 - blue. 1 Pat. = 4 sts, 6 rows.

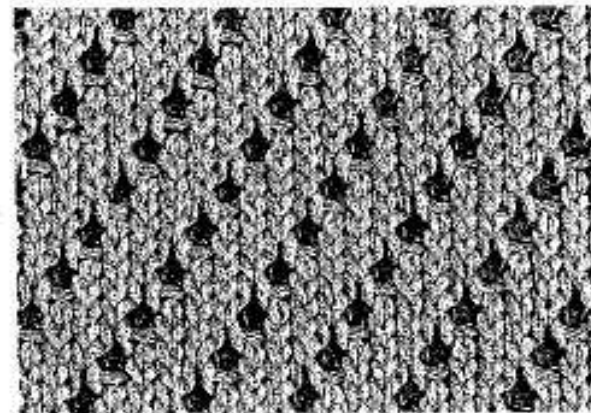

Card 15 — A, Col. 1 - white. 1 Pat. = 12 sts, 24 rows.

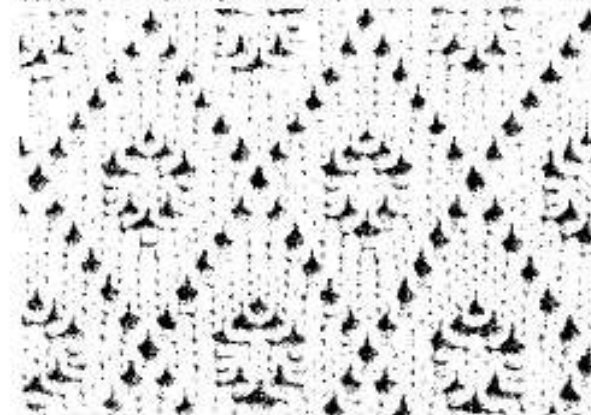

Card 20 — A, Col. 1 - blue. 1 Pat. = 24 sts, 54 rows.

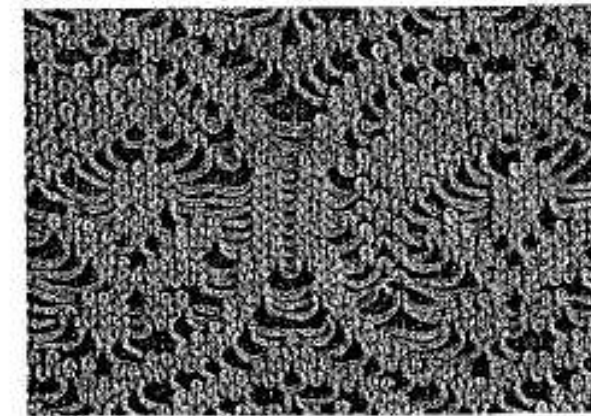

KNITTING — F — FAIR ISLE PATTERNS

This is a perfect chance to use your own ideas and talents with colors. Study this and the next page carefully and soon you will enjoy the fun and excitement of Multi-color (Fair Isle) knitting. A very wide selection of Fair Isle patterns can be knitted on your machine.

- You will be learning how to knit TWO colors in ONE row at a time.
- All colors in a Fair Isle pattern MUST be SAME thickness yarn.
- The Tension Dial should be set ONE NUMBER HIGHER (LOOSER) than for normal knitting. For example, if using a yarn in stocking stitch at Tension 6, for Fair Isle knitting the Tension setting should be 7. Always knit a Tension Swatch in the Fair Isle pattern you wish to use before you start knitting the garment.
- The main color or Col. 1 is threaded through the RIGHT side feed points of the Yarn Brake and through Yarn Feeder 1.
The second color or Col. 2 is threaded through the LEFT side feed points of the Yarn Brake and in Feeder 2, making sure it is well at the LEFT of the Feeder Guide pin.
- If knitting Fair Isle patterns with more than 2 colors, just change the colors in Feeder 2 and hold the yarn of the additional colors above the carriage as for knitting in the Nylon Cord.

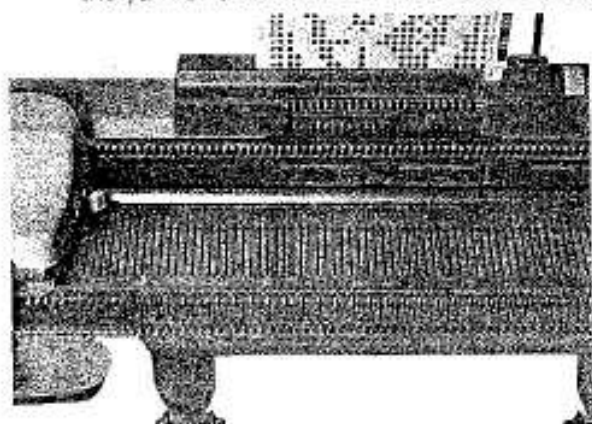

Thread col. 1 through all RIGHT side feed points of the Yarn Brake and through Feeder 1. Cast-on open edge 60 needles and knit 6 rows, carriage is at LEFT and Row Counter shows 7. Set Arm Levers to O. Set card release to ▼. Insert card 20 with A at RIGHT side bottom, secure ends of card with clamps and turn card until 54 shows at row indicator. Leave card release to ▼.

Take the claws and insert them through the edges of the knitting.

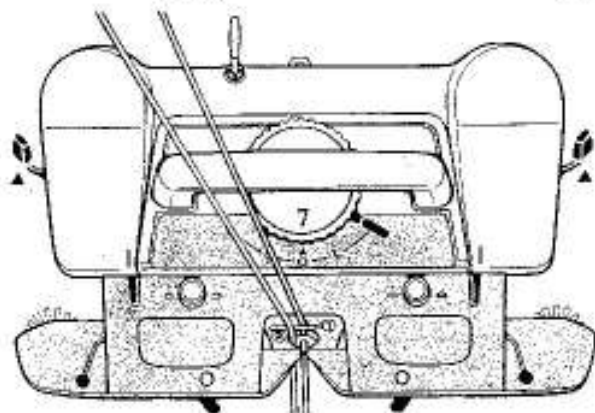

Knit 1 row to the RIGHT.
Row indicator shows 1 and Row Counter 8.

Thread col. 2 through all LEFT side feed points of the Yarn Brake and through the Feeder 2. Fasten the end onto the Table Clamp.

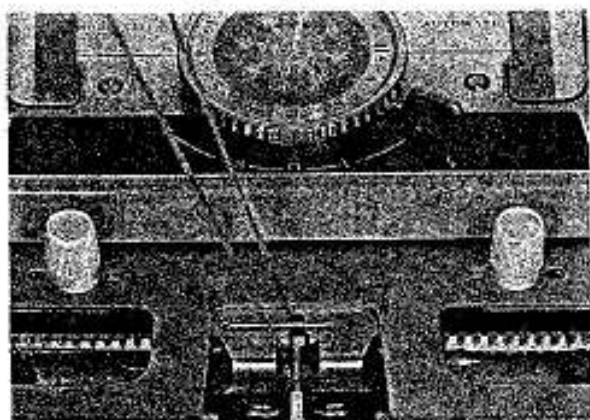

MAKE SURE col 2, is well at the LEFT of the Feeder Guide pin.
Set Side Levers BACK - Front Levers to II.
Set Cam Lever to F - Arm Lever to O.

KNITTING — F — FAIR ISLE PATTERNS

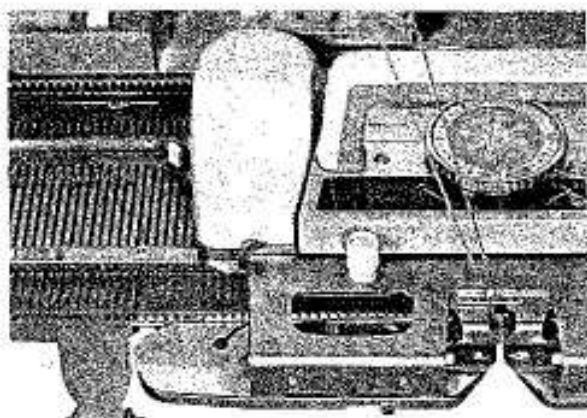

At the RIGHT, bring the first needle to D position.
Knit to the LEFT.
At the LEFT bring the first needle to D position.
Knit to the RIGHT.

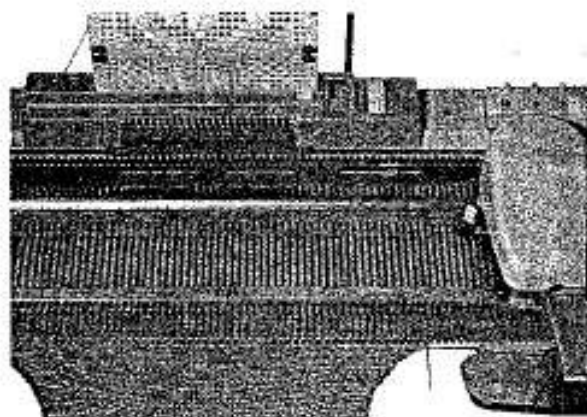

Continue knitting, ALWAYS bringing the first needle to D position.
Bring the claws up and insert the through the last rows of knitting.

NOTE: When doing partial knitting, have the Front Levers set to I, but then bring the first needle to C position only.

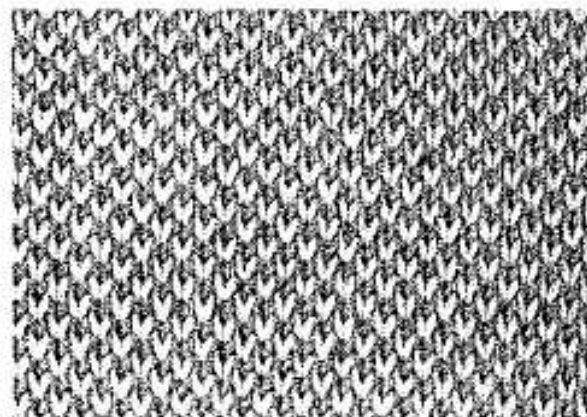

Card 1 — A, Col. 1 - green, Col. 2 - grey.
1 Pat. = 2 sts, 2 rows.

Card 2 — A, Col. 1 - red, Col. 2 - grey.
1 Pat. = 4 sts, 4 rows.

Card 3 — A, Col. 1 - green, Col. 2 - white.
1 Pat. = 4 sts, 8 rows.

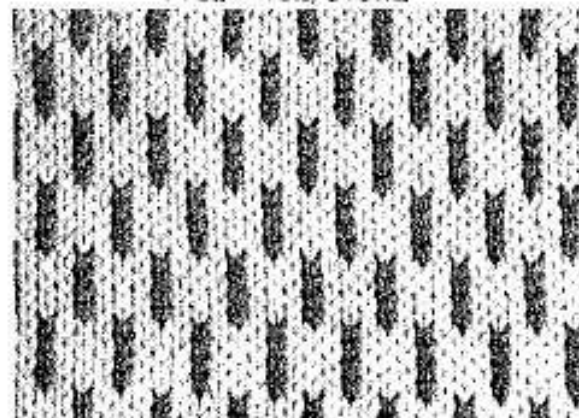
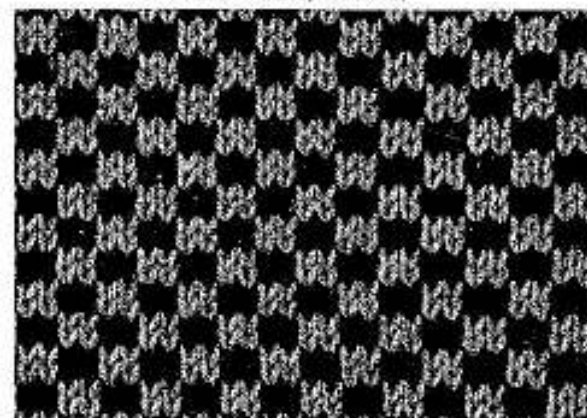

KNITTING — F — FAIR ISLE PATTERNS

Card 4 — A, Col. 1 - blue, Col. 2 - grey,
1 Pat. = 4 sts, 4 rows.

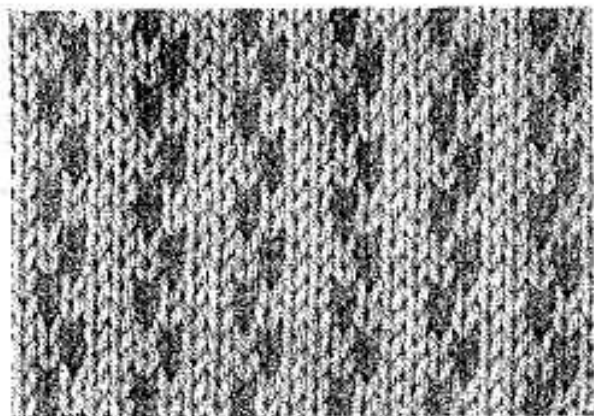

Card 5 — A, Col. 1 - green, Col. 2 - yellow,
1 Pat. = 4 sts, 8 rows.

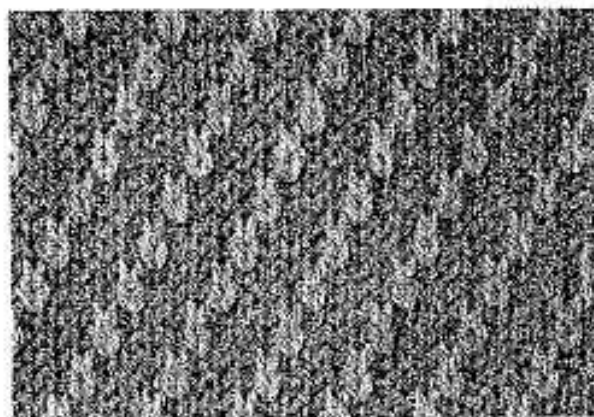

Card 7 — A, Col. 1 - white, Col. 2 - red,
1 Pat. = 2 sts, 4 rows.

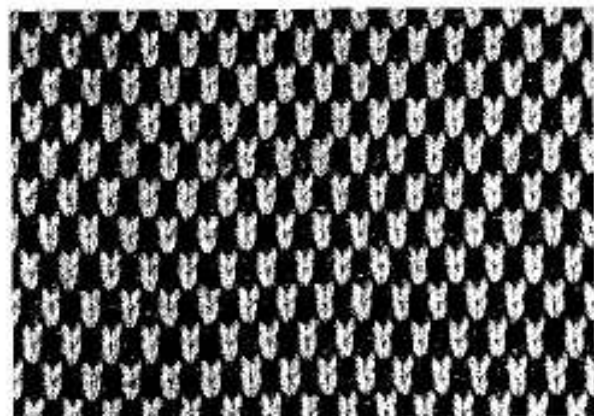

Card 8 — A, Col. 1 - white, Col. 2 - blue,
1 Pat. = 3 sts, 18 rows.

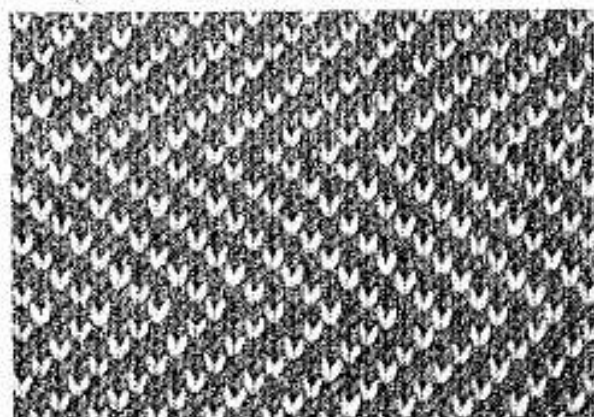

Card 9 — A, Col. 1 - white, Col. 2 - red,
1 Pat. = 12 sts, 24 rows.

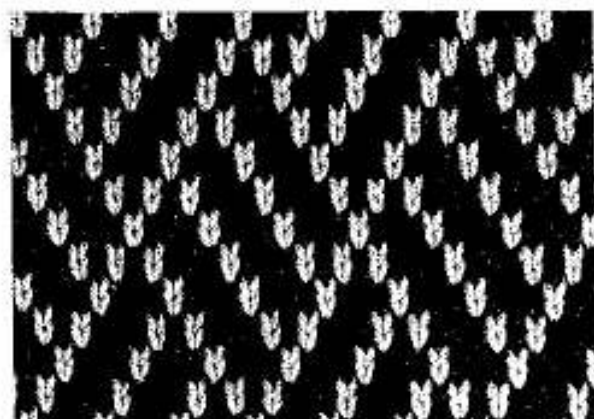

Card 10 — A, Col. 1 - red, Col. 2 - grey,
1 Pat. = 12 sts, 20 rows.

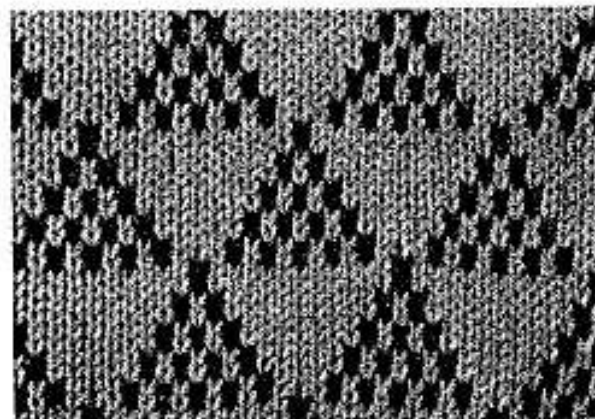

KNITTING — F — FAIR ISLE PATTERNS

Card 11 — A, Col. 1 - grey, Col. 2 - red.
1 Pat. = 8 sts, 24 rows.

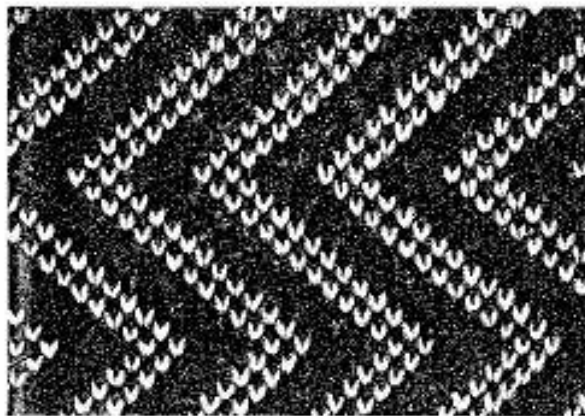

Card 12 — A, Col. 1 - blue, Col. 2 - white.
1 Pat. = 12 sts, 24 rows.

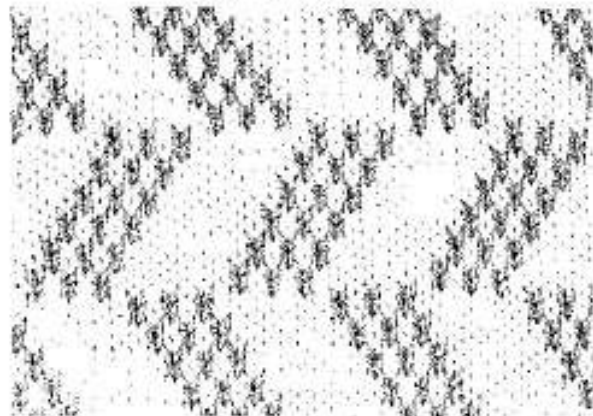

Card 13 — A, Col. 1 - yellow, Col. 2 - green.
1 Pat. = 8 sts, 5 rows.

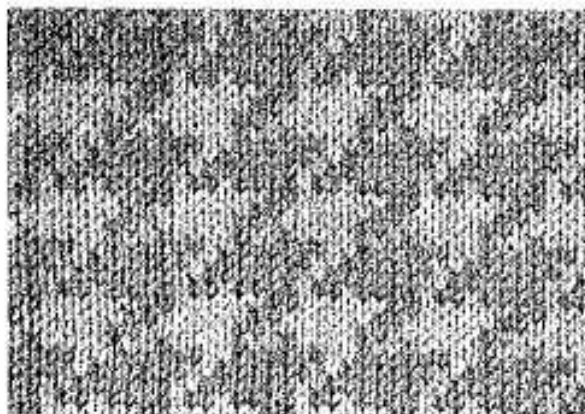

Card 14 — A, Col. 1 - grey, Col. 2 - green.
1 Pat. = 24 sts, 12 rows.

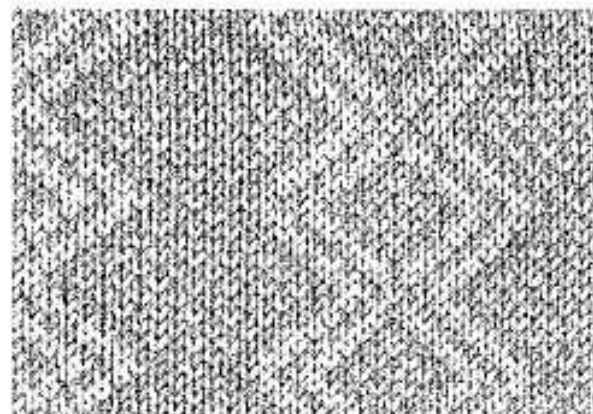

Card 15 — A, Col. 1 - white, Col. 2 - green.
1 Pat. = 12 sts, 24 rows.

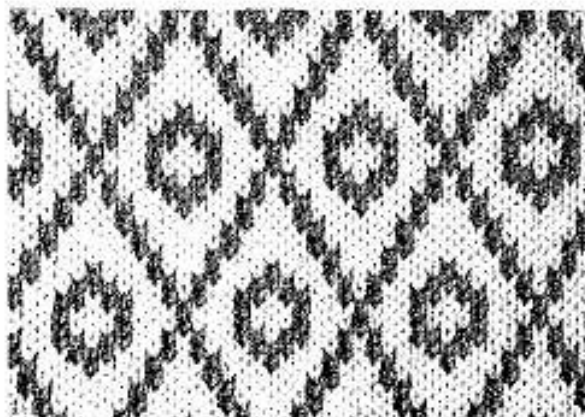

Card 16 — A, Col. 1 - white, Col. 2 - red.
1 Pat. = 24 sts, 30 rows.

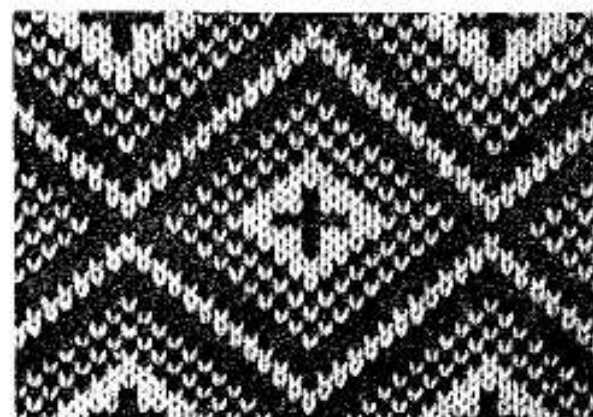

KNITTING — F — FAIR ISLE PATTERNS

* Means repeat the instructions from this point.

Card 17 — A, Col. 1 - blue, Col. 2 - red,
1 Pat. = 24 sts, 30 rows.

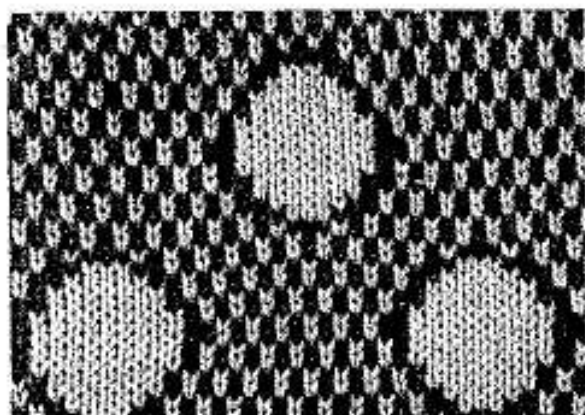

Card 18 — A, Col. 1 - red, Col. 2 - grey.
1 Pat. = 24 sts, 44 rows.

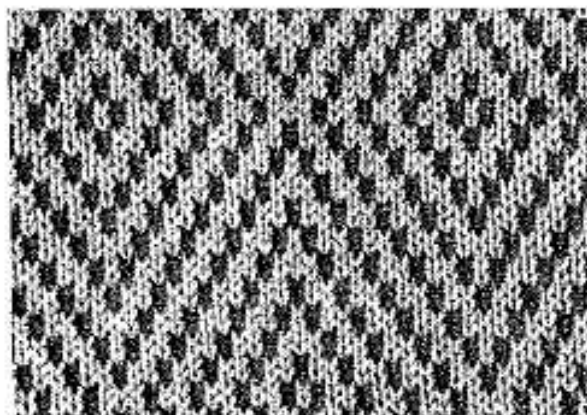

Card 19 — A, Col. 1 - white, Col. 2 - green,
1 Pat. = 24 sts, 24 rows.

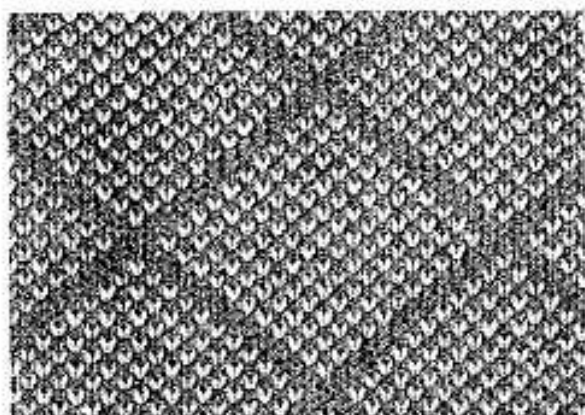

Card 20 — A, Col. 1 - green, Col. 2 - yellow,
1 Pat. = 24 sts, 54 rows.

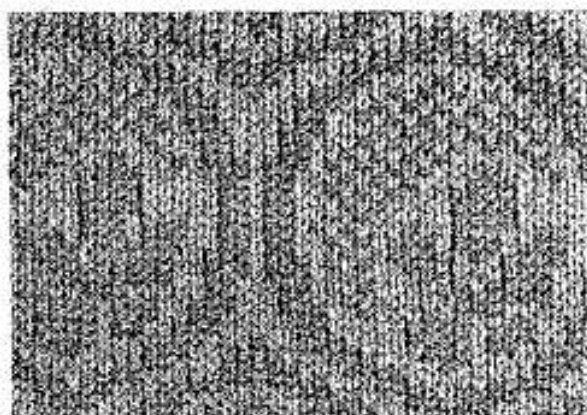

Card 3 — A, Col. 1 - green, Col. 2 - grey,
Col. 3 - brown, Col. 4 - orange.

VARIATION 2, 1 Pat. = 2 sts, 22 rows.

- * Knit 10 rows col. 2 in Feeder 2.
- Knit 4 rows col. 3 in Feeder 2.
- Knit 4 rows col. 4 in Feeder 2.
- Knit 4 rows col. 3 in Feeder 2.

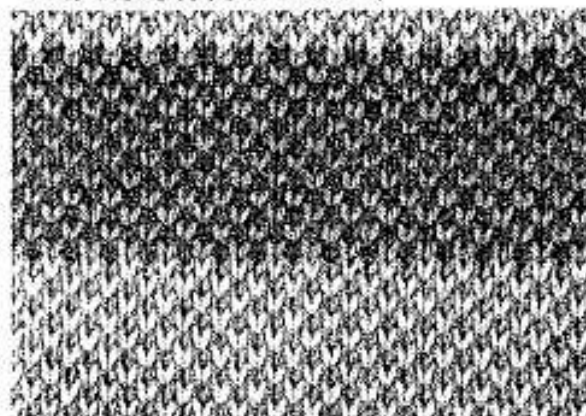

Card 1 — A, Col. 1 - yellow, Col. 2 - red.

VARIATION 3, 1 Pat. = 2 sts.

After knitting pre-set row 60 — 1,

set card release to ● and continue knitting.

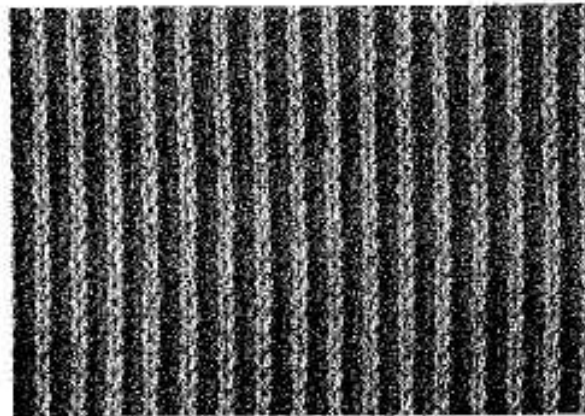

KNITTING – F – FAIR ISLE PATTERNS

* Means repeat the instructions from this point

Card 2 – A, Col. 1 - white, Col. 2 - green,
Col. 3 - blue, Col. 4 - red.

VARIATION 1, 1 Pat. = 4 sts, 6 rows.

- * Knit 2 rows col. 2 in Feeder 2.
- Knit 2 rows col. 3 in Feeder 2.
- Knit 2 rows col. 4 in Feeder 2.

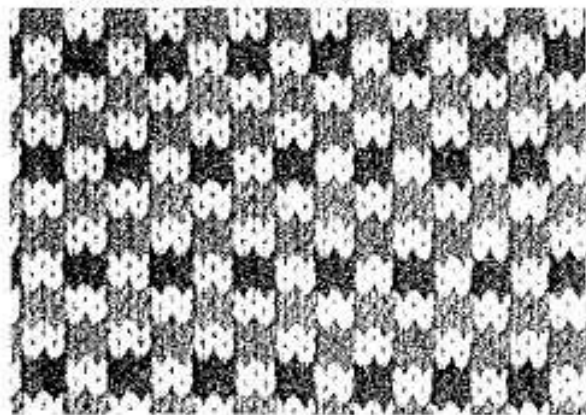

Card 2 – A, Col. 1 - blue, Col. 2 - white.

VARIATION 2, 1 Pat. = 4 sts.

After knitting pre-set row 60 – 1,
set card release to ● and continue knitting.

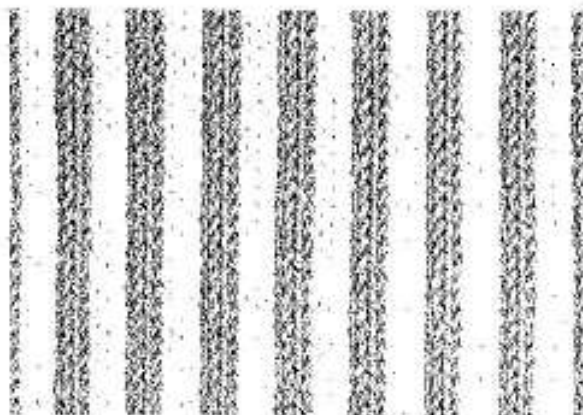

Card 2 – A, Col. 1 - blue, Col. 2 - red,
Col. 3 - blue, Col. 4 - red.

VARIATION 3, 1 Pat. = 4 sts, 8 rows.

After knitting pre-set row 60 – 1,

set card release to ●.

- * Knit 4 rows col. 2 in Feeder 2. Set Cam Lever to center 0, knit 4 rows col. 1 only.

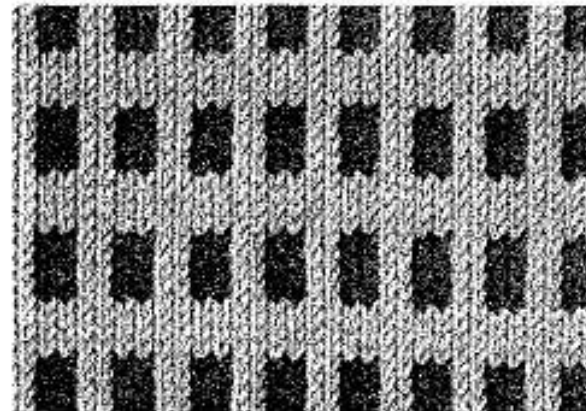

Card 3 – A, Col. 1 - yellow, Col. 2 - green,
Col. 3 - red.

VARIATION 6, 1 Pat. = 4 sts, 8 rows.

After knitting pre-set row 68 – 1,

- * Knit 4 rows col. 2 in Feeder 2.
- Knit 4 rows col. 3 in Feeder 2.

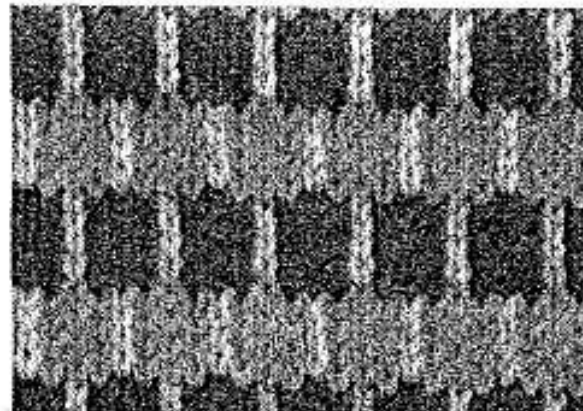

Card 5 – B, Col. 1 - yellow, Col. 2 - brown,

VARIATION 1, 1 Pat. = 4 sts, 8 rows.

By inserting the card having B at RIGHT side bottom, the stripes are knitted in the opposite direction.

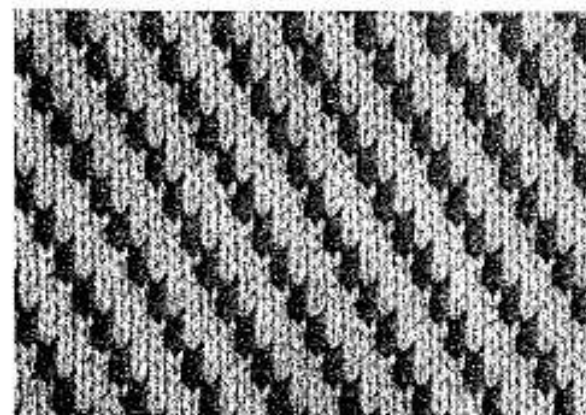

Card 8 – A, Col. 1 - yellow, Col. 2 - brown,
Col. 3 - red.

VARIATION 1, 1 Pat. = 3 sts, 18 rows.

After knitting pre-set row 54 – 1,

- * Knit 10 rows col. 2 in Feeder 2.
- Knit 8 rows col. 3 in Feeder 2.

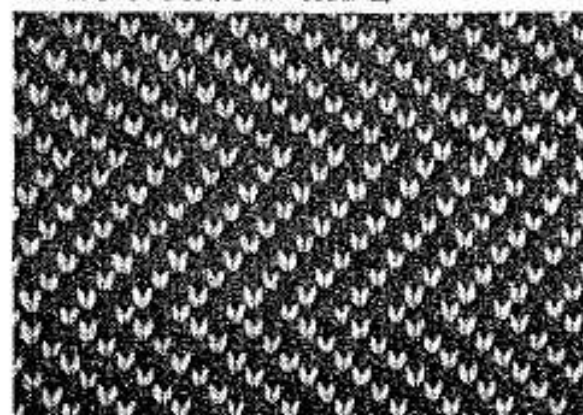

KNITTING — F — FAIR ISLE PATTERNS

* Means repeat the instructions from this point.

Card 9 — A, Col. 1 - brown, Col. 2 - green,
 VARIATION 2. 1 Pat. = 12 sts, 30 rows.
 After knitting pre-set row 48 -- 1,
 * Card release to ● - knit 6 rows.
 Card release to ▼ - knit 12 rows.

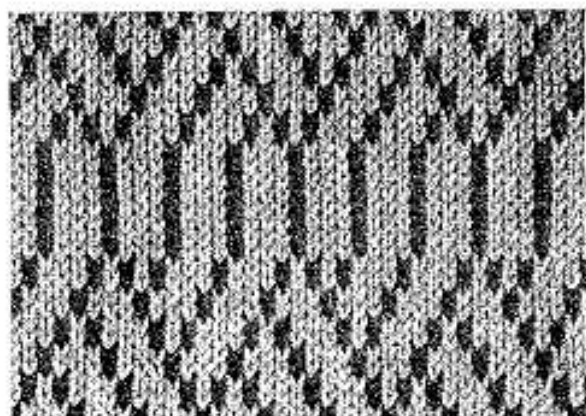

Card 10 — A, Col. 1 - white, Col. 2 - red,
 Col. 3 - blue.
 VARIATION 2. 1 Pat. = 12 sts, 20 rows.
 After knitting pre-set row 60 — 1,
 * Knit 10 rows col. 2 in Feeder 2,
 Knit 10 rows col. 3 in Feeder 2.

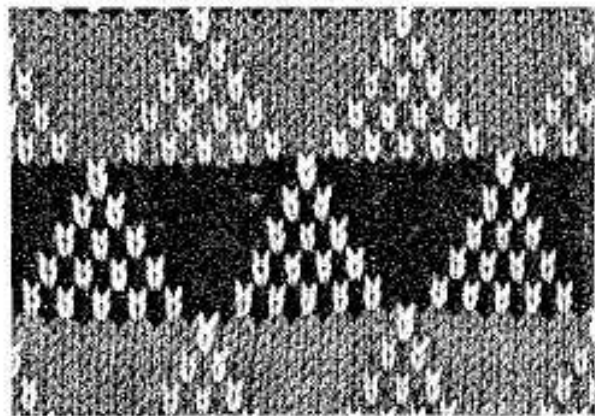

Card 10 — A, Col. 1 - brown, Col. 2 - yellow,
 Col. 3 - green.
 VARIATION 3. 1 Pat. = 12 sts, 20 rows.
 After knitting pre-set row 60 — 1,
 * Knit 2 rows col. 2 in Feeder 2,
 Knit 2 rows col. 3 in Feeder 2.

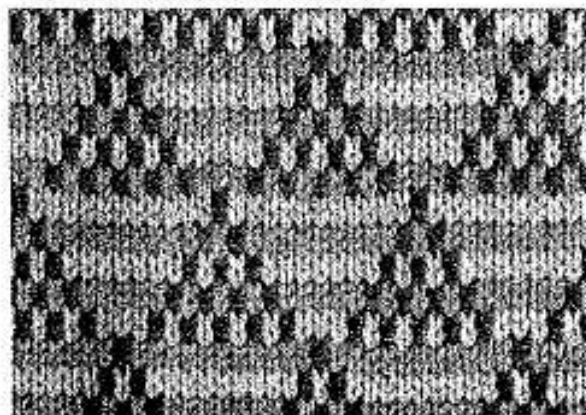

Card 10 — A, Col. 1 - red, Col. 2 - white,
 VARIATION 4. 1 Pat. = 12 sts, 40 rows.
 After knitting pre-set row 60 — 1,
 Card release to ● - knit 3 rows, card release to ▼,
 and turn 2 rows UP - card release to ●.
 * Knit 4 rows, turn card 2 rows UP, card release ●.

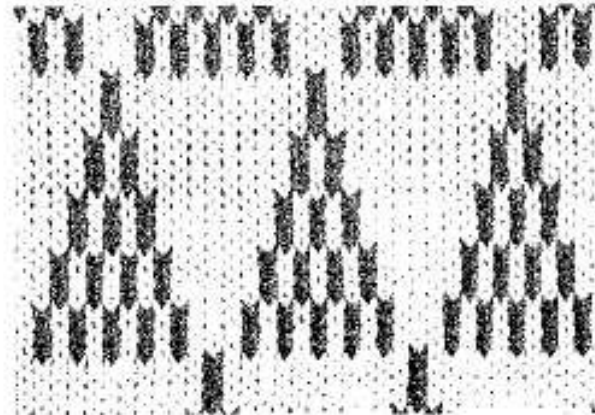

Card 11 — A, Col. 1 - brown, Col. 2 - green,
 VARIATION 2. 1 Pat. = 8 sts, 24 rows.
 After knitting pre-set row 6 — 7,
 * Knit 12 rows col. 2 in Feeder 2,
 Knit 12 rows col. 3 in Feeder 2.

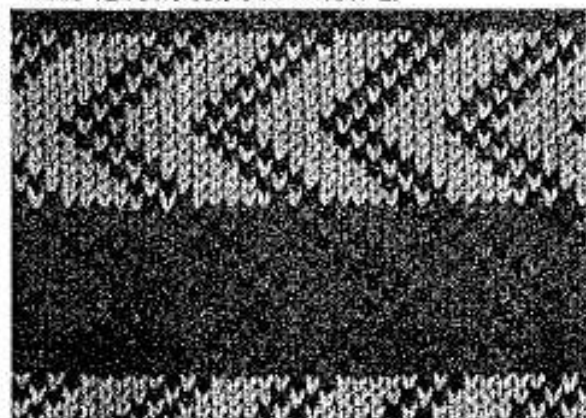

Card 11 — A, Col. 1 - brown, Col. 2 - yellow,
 VARIATION 3. 1 Pat. = 8 sts, 10 rows.
 After knitting pre-set row 6 — 7,
 Knit 9 rows with both colours.
 * Turn card to 7, knit 10 rows.

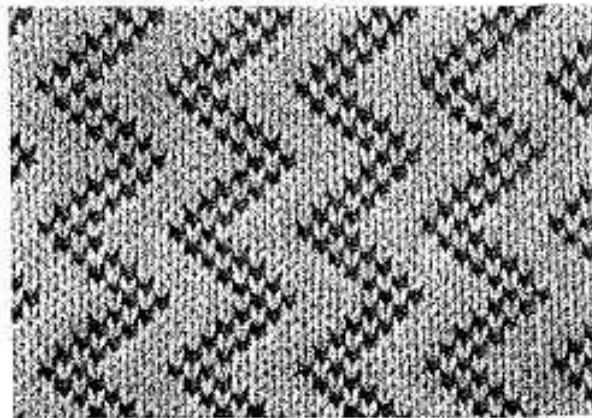

KNITTING – F – FAIR ISLE PATTERNS

* Means repeat the instructions from this point.

Card 11 – A, Col. 1 - grey, Col. 2 - green.

VARIATION 4, 1 Pat. = 8 sts, 48 rows.

After knitting pre-set row 48 – 1,

* Card release to ▼ - knit 2 rows.

Card release to ● - knit 2 rows.

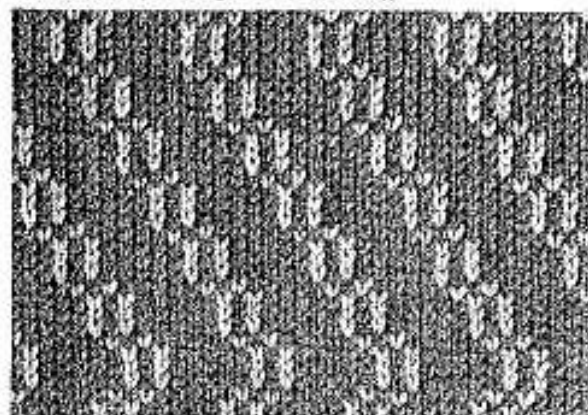

Card 12 – A, Col. 1 - white, Col. 2 - red.

VARIATION 3, 1 Pat. = 12 sts, 12 rows.

After knitting pre-set row 48 – 1,

* Knit to 12, turn card BACK to 48.

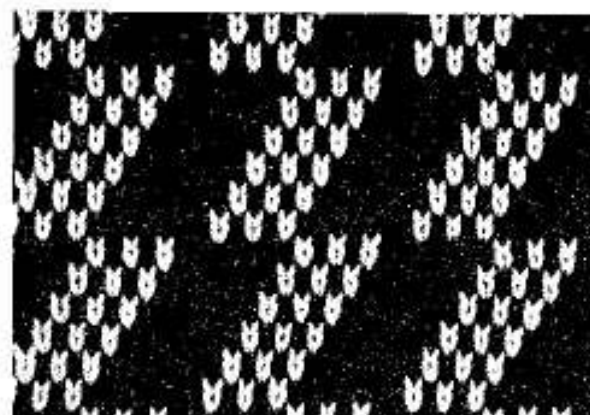

Card 13 – A, Col. 1 - white, Col. 2 - brown,
Col. 3 - pink.

VARIATION 1, 1 Pat. = 8 sts, 8 rows.

After knitting preset row 4 – 5,

* Knit 8 rows col. 2 in Feeder 2.

Knit 8 rows col. 3 in Feeder 2.

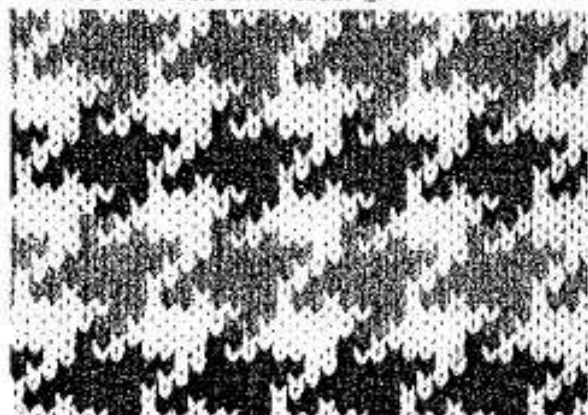

Card 14 – A, Col. 1 - pink, Col. 2 - brown.

VARIATION 2, 1 Pat. = 24 sts, 24 rows.

After knitting pre-set row 60 – 1,

* Card release to ▼ - knit 2 rows.

Card release to ● - knit 2 rows.

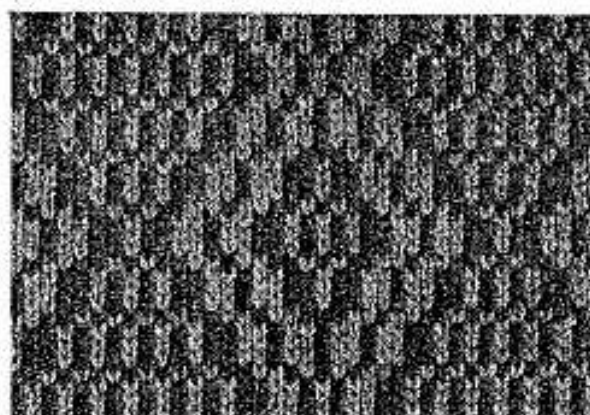

Card 14 – A, Col. 1 - green, Col. 2 - yellow.

VARIATION 3, 1 Pat. = 24 sts, 6 rows.

After knitting pre-set row 60 – 1,

* Knit to 6 – turn card BACK to 60.

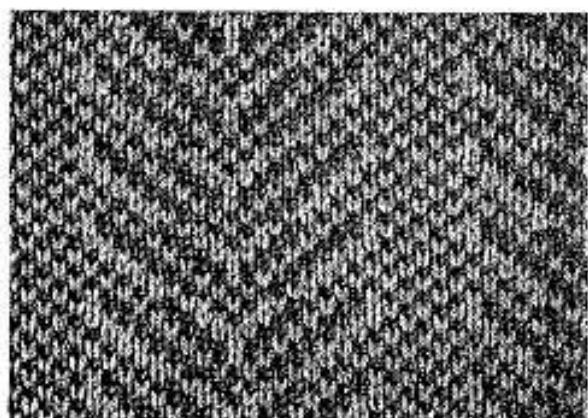

Card 14 – A, Col. 1 - green, Col. 2 - white.

VARIATION 4, 1 Pat. = 24 sts, 24 rows.

After knitting pre-set row 60 – 1,

* Card release to ▼ - knit 4 rows.

Card release to ● - knit 4 rows.

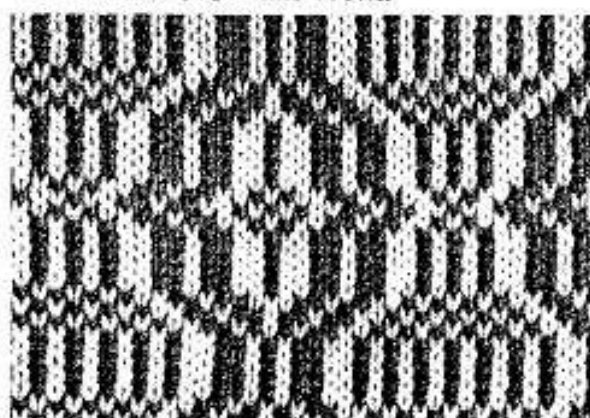

KNITTING - F - FAIR ISLE PATTERNS

* Means repeat the instructions from this point.

Card 15 - A. Col. 1 blue, Col. 2 - white,
VARIATION 1. 1 Pat. 12 sts, 34 rows.

* Card release ● - knit 10 rows.

Card release ▼ - knit 12 rows.

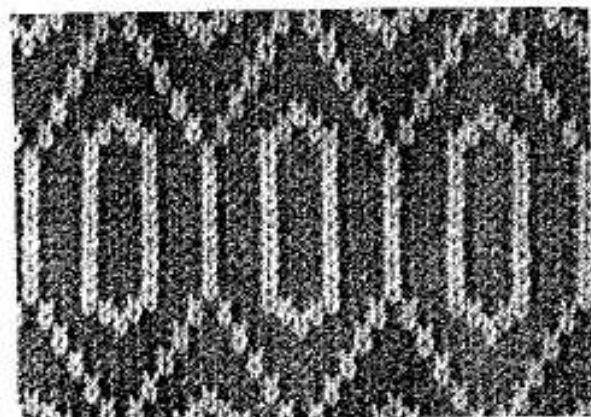

Card 16 - A. Col. 1 blue, Col. 2 - white,
VARIATION 2. 1 Pat. = 24 sts, 20 rows.

After knitting pre-set row 9 - 10,

* Knit 10 rows, turn card UP to 40.

Knit 10 rows, turn card UP to 10.

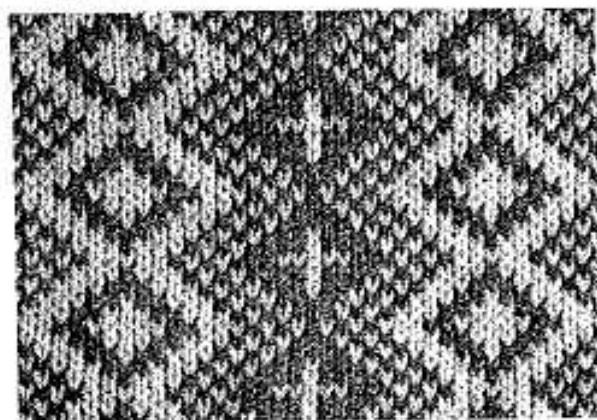

Card 16 - A. Col. 1 - red, Col. 2 - white,

VARIATION 3. 1 Pat. 24 sts, 60 rows.

After knitting pre-set row 60 - 1,

* Card release to ▼ - knit 2 rows.

Card release to ● - knit 2 rows.

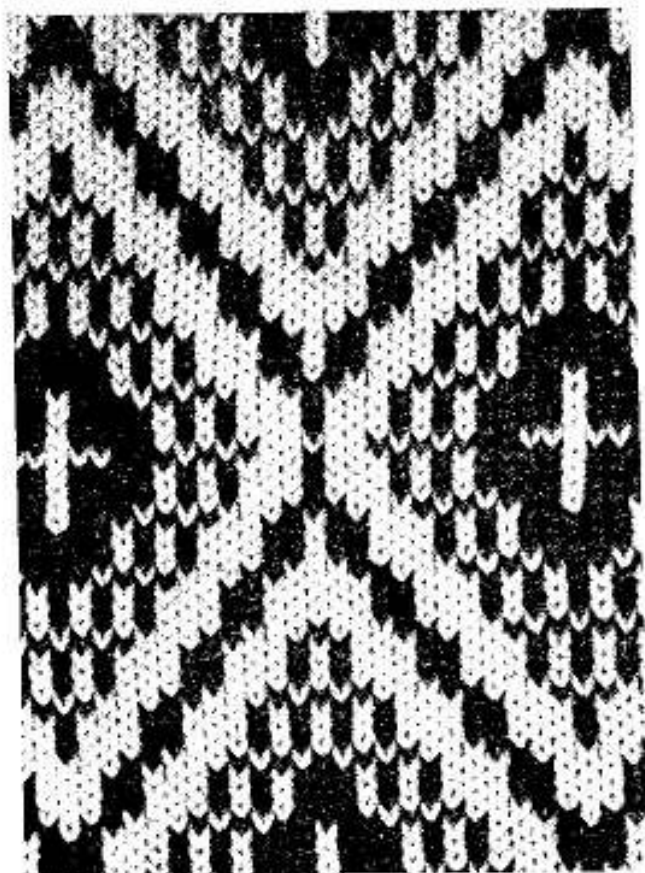

GENERAL INDEX

ACCESSORIES	2
BACKSTITCH	33
BINDING OFF	27
	As decreasing 41
BUTTONHOLES	73
	Small 74
	Single 74
	Band 76
CARRIAGE JAMMING	85
CASTING OFF	22
	Open edge 24
	Closed edge automatic 25
	Closed edge by hand 25
CHANGING A NEEDLE	89
CORD	29
	Knitted 34
	Twisted 34
DARTS	70
	In plain knitting and patterns 70
DECREASING	41
	One stitch 41
	Many stitches 41
	Fully fashioned 53
DROPPED STITCHES	81
ERRORS	80
FAIR ISLE PATTERNS	110
FINISHING METHODS	32
FRINGES	29
GRAFTING	32
HEMS	36
	Simple double hem 39
	Picot hem 39
HINTS	80
INCREASING	40
	One stitch 40
	Many stitches 40
	Fully fashioned 53
JOINING YARN	28
KNITTING STRIPES	28
LACE PATTERNS	108

— GENERAL INDEX

LATCH NEEDLE	6
MAIN PARTS OF MACHINE	7
MAINTENANCE OF MACHINE	90
MATTRESS STITCH	33
NECKLINES	56
	V neck in plain knitting 56
	V neck in patterned garments 59
	Round neck (Method 1) 60
	Round neck (Method 2) 63
NEEDLE POSITIONS	14
POCKETS	67
	In plain knitting 67
	In patterned garments 69
POM PONS	34
PREPARATION OF YARNS	4
INSERTING OF PATTERN CARDS	94
REPACKING OF THE MACHINE	91
RIBBINGS	42
	1 by 1 Double Welt 42
	2 by 1 Double Welt 51
	3 by 1 Double Welt 52
ROW COUNTER	12
SETTING UP THE MACHINE	10
SEWING UP HEMS	32
SHOULDER SHAPINGS	72
STEAMING	28
	A fabric 28
	The welts 48
STITCH PATTERNS	95
	Tuck Stitch Patterns 95
	Fair Isle 110
	Lace 108
	Slip Stitch Patterns 99
	Weaving 102
TENSION AND STITCH SIZES	30
TENSION SWATCH	31
THREADING UP	19
TRANSFERRING STITCHES	38
UNPACKING THE MACHINE	8
UNRAVELLING	83
YARN BRAKE	19
YARN FEEDER	20