

OPERATION MANUAL

MOD. 360/260

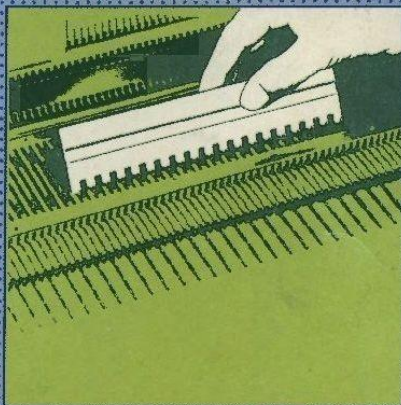
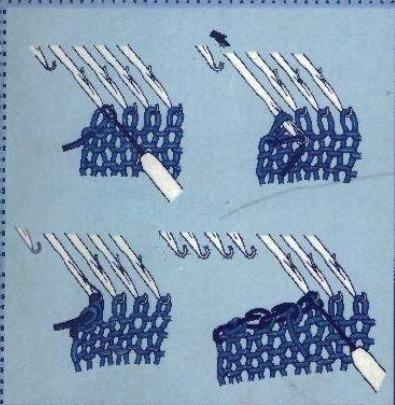
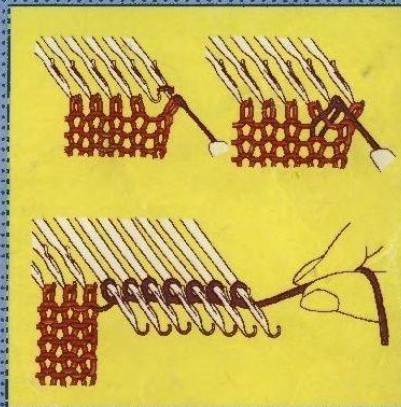
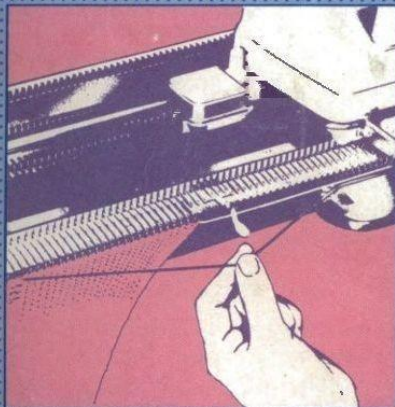

OPERATION MANUAL

MOD. 360/260

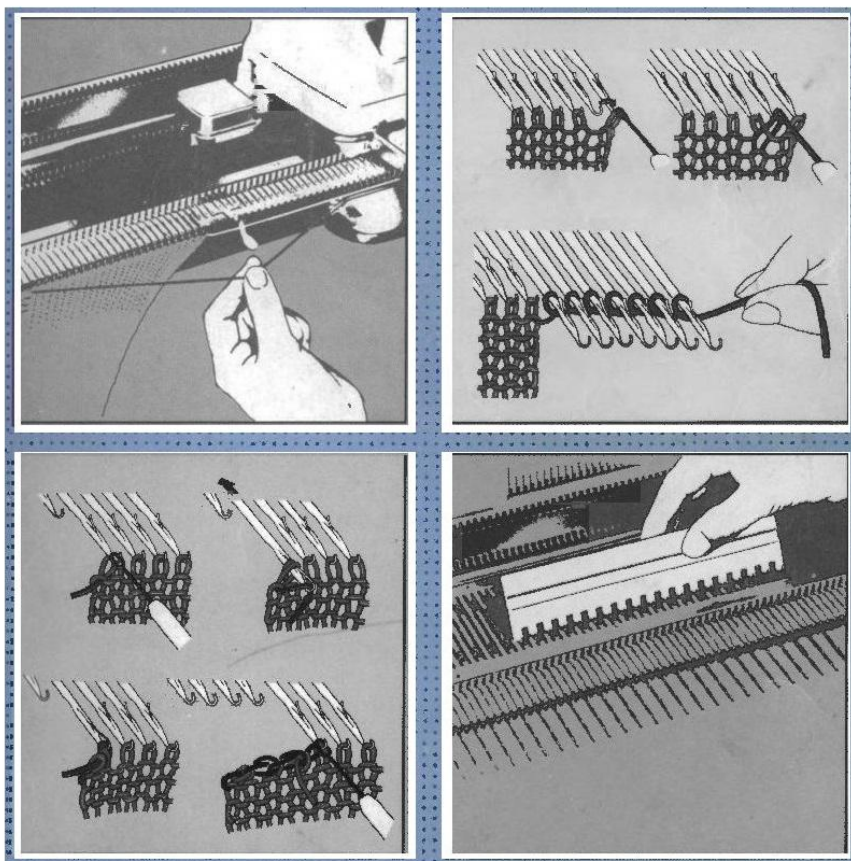

PREFACE

Our congratulations to you on the purchase of your new knitting machine — Model 360/260.

This Operation Manual has been prepared to assist you in using and operating your knitting machine. It is composed of four parts as prescribed below.

PART 1 — Using 360/260KL Pages 1–20

Part one contains the easy-to-follow basic information required for yarn preparation before knitting, setting up of the machine, cast on and stockinet knitting with the Main Carriage.

The Lace Carriage and its use is covered in PART 3.

If you are anxious to knit a garment in stockinet knitting while using the Main Carriage, refer to the Knitting Manual. Should you wish to use the Lace Carriage instead, refer to PART 3.

PART 2 — Using 360/260K Carriage Pages 21–42

Part two gives necessary information to knit a wide range of stitch patterns in mono/polycolours using the Punch Card. Over a hundred stitch pattern samples have been introduced in the Pattern Book.

PART 3 — Using 360/260L Carriage Pages 43–60

Part three contains the easy-to-follow basic information required for the Lace Carriage covering setting up of the Lace Carriage, cast on, stockinet knitting and how to knit lace patterns using the Punch Card.

PART 4 — Using 360/260KL Pages 61–71

Part four guides you to WHAT TO DO, HOW TO DO and MAINTENANCE of the machine as a lifetime companion of you.

If you are in need of further information or knitting accessories for your machine, please do not hesitate to call on your nearest knitting shop or service centre.

Enjoy knitting!

CONTENTS

MACHINE AND ACCESSORIES	1
PREPARATION OF YARNS	3
SETTING UP THE KNITTER AND KNITTING	4
PATTERN KNITTING WITH MAIN CARRIAGE	21
Knit-in (Fair Isle)	25
Slip stitch pattern	27
Slip stitch pattern in colour	27
Tuck stitch pattern	29
Tuck stitch pattern in colours	30
Tuck lace	31
Punch lace	32
Weaving	33
Plating	35
Single motif	37
LACE CARRIAGE	43
PATTERN KNITTING WITH LACE CARRIAGE	54
Plain lace	56
Fashion lace	57
Single motif lace	59
HELPFUL HINTS	61
MAINTENANCE	71
REPACKING THE KNITTER	72
INDEX	73

MACHINE AND ACCESSORIES

260K/L Knitter

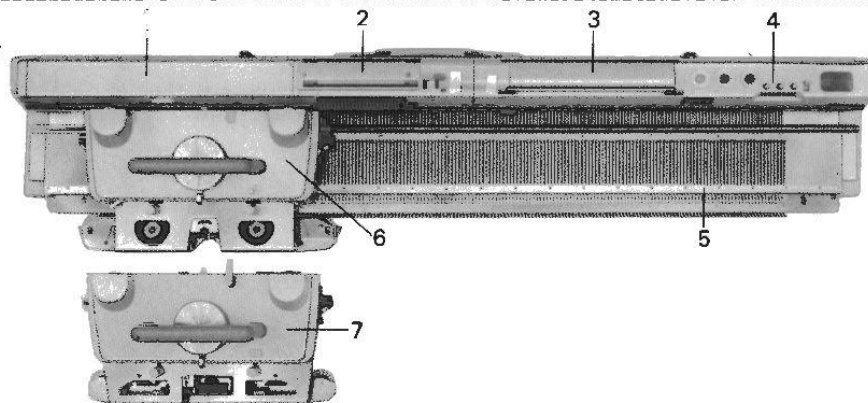

360K/L Knitter

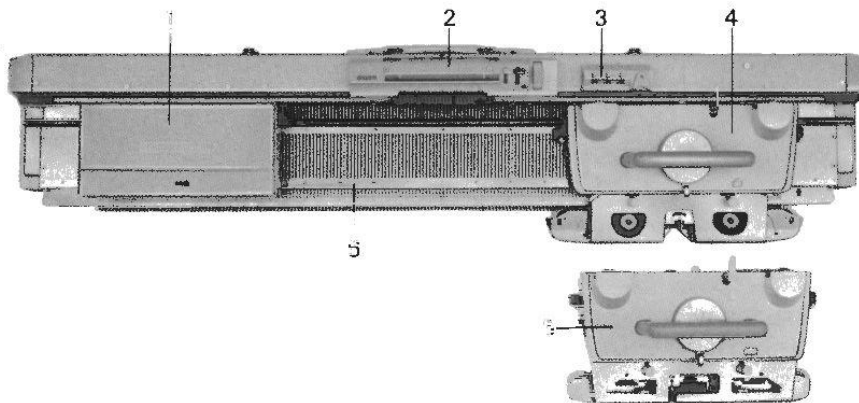

260K/L

- Built-in Accessory Box
- Pattern Card Panel
- Knit Contour (Radar)
- Row Counter
- Needle Bed
- Main Carriage
- Lace Carriage

360K/L

- Accessory Box
- Pattern Card Panel
- Row Counter
- Main Carriage
- Lace Carriage
- Needle Bed

ACCESSORIES – 360/260K

1	Clamp (2)	07321201	16	Yarn Separator (4)	17221201
2	Carriage Fastener		17	Magic Cam (2)	
	360KL	07080617		left	07171606
	260KL	07241201		right	07161607
3	Auto Tension	07011604	18	Card Guide *	17581000
4	Yarn Rod	07021751	19	Spare Needle (3)	01130616
5	Claw Weight (2)	07422009	20	Cleaning Brush	07342009
6	Ravel Cord (3)	07332000	21	Oil	07922008
7	Gauge Scale	08252116	22	Auxiliary Feeding	
8	Needle Pusher	07292006		Cam **	07170814
9	Transfer Tool		23	Scale Set **	
	1 x 2	07352008		Stitch Scale (7)	08142119
	1 x 3	07362007		Centre Scale (6)	08242117
	2 x 3	07372006	24	Pattern Paper (19) **	07740509
10	Tapestry Needle	07402001			
11	Tappet	07312002			
12	Crochet Hook	07440621			
13	Punch Card (20)	07701618			
14	Card Snap (4)	17191008			
15	Pont Cam M (4)				
	left	07641756			
	right	07631757			

* exclusive for 260K/L
** exclusive for 360K/L

(To order, specify part name with part number)

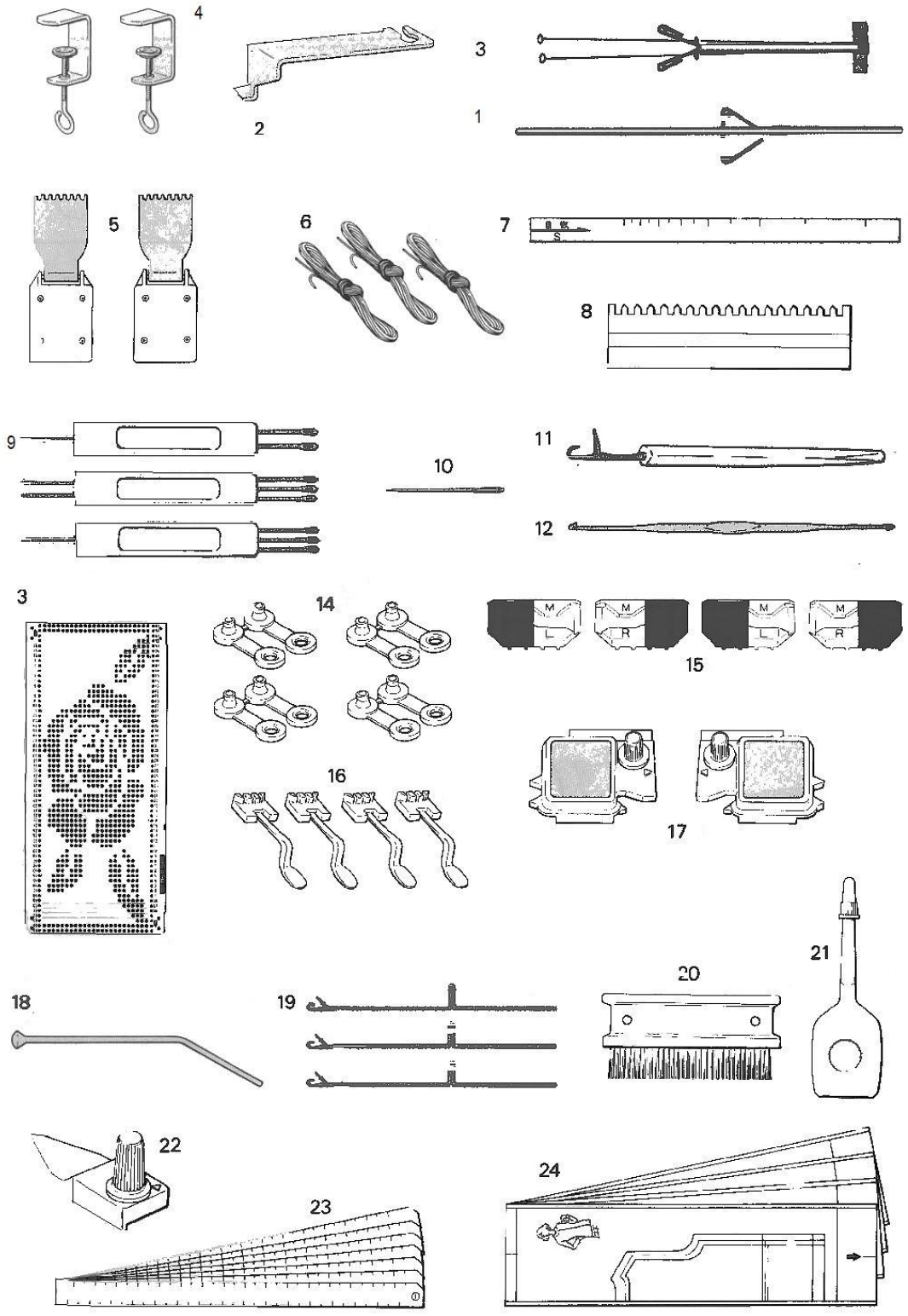

PREPARATION OF YARNS

Your machine has been designed to give you perfect results using a wide range of yarns from cotton thread to very thick yarn. However, for practice it is best to start with A NEW MEDIUM 4-PLY YARN (see page 9).

Correct preparation of yarns before you start knitting is very important. This extra care will make knitting more enjoyable, easier, and the quality of your garment much better.

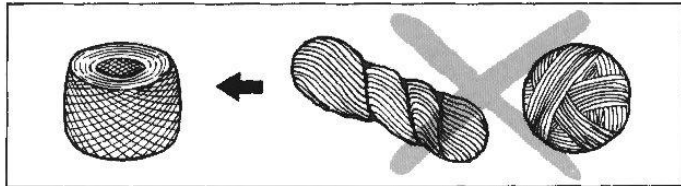
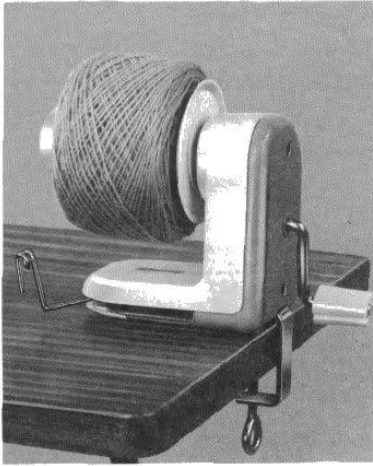

It is impossible to knit from a hank of yarn or hand wound ball. You must open it and place it on your arms (or on an optional Skein Holder) to wind it into a ball, suitable for machine knitting. For winding yarn, use of an optional Yarn Ball Winder is recommended.

Yarn Ball Winder, a useful optional accessory.

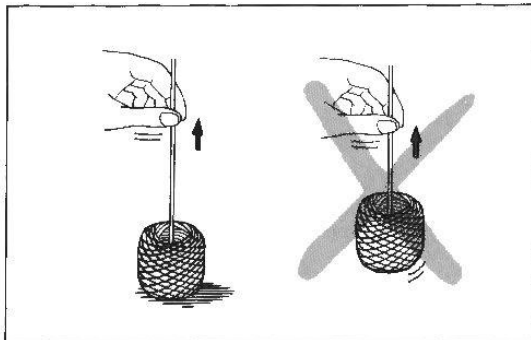
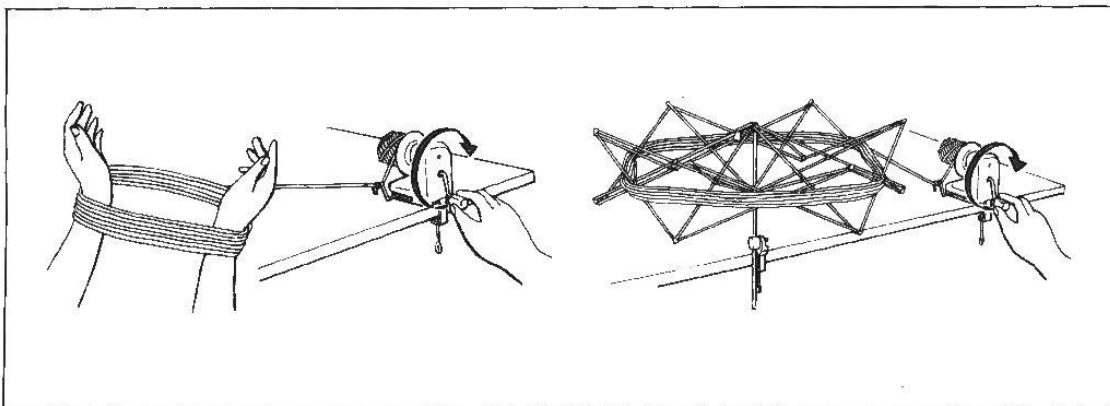

When yarn is rewound, ensure that the yarn end comes out freely without lifting the ball from the table.

We recommend you wax the yarn during winding by simply letting the yarn run over an ordinary white candle or knitting wax.

SETTING UP THE KNITTER

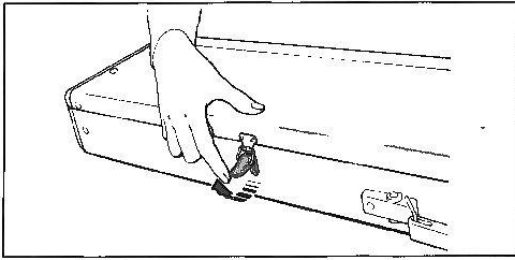

Place the Knitter on a table with the Carrying Handle away from you.

Unfasten the latches.

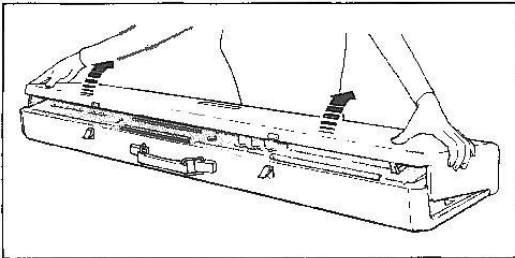

Lift the Top Cover slightly, pull it towards you and remove it from the Knitter.

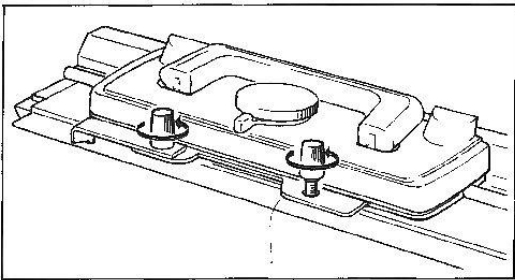

Loosen both Arm Nuts by turning them in the arrowed direction.

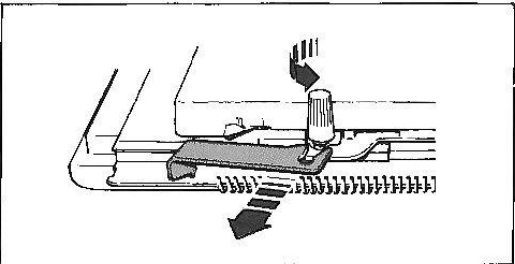

Remove the Carriage Fastener.

Do not lose the Carriage Fastener as this is used for securing the Carriage to the Needle Bed while the Knitter is not in use.

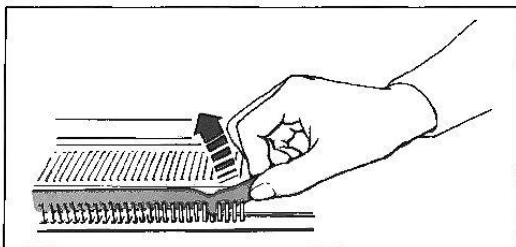

Remove cardboard needle protector from the front of the Needle Bed.

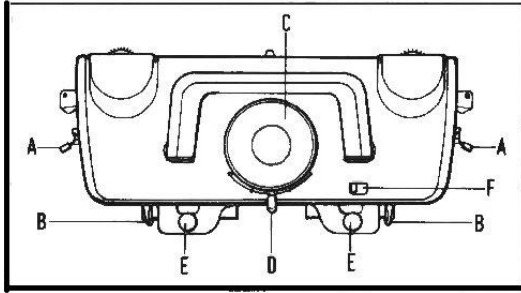
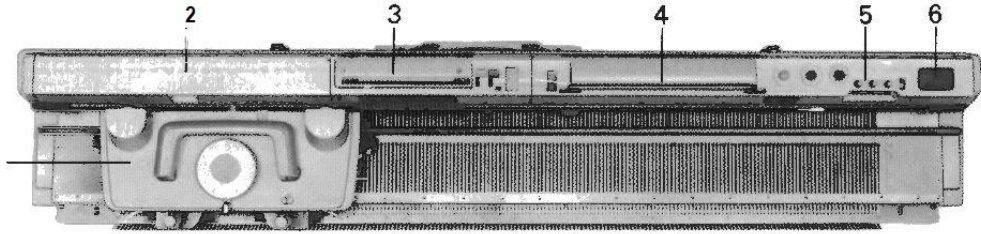

1. CARRIAGE

- A - Side Levers
- B - Russel/Front Levers
- C - Stitch Dial
- D - Cam Lever
- E - Arm Nuts
- F - Release Lever

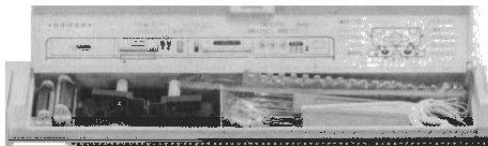

2. BUILT-IN ACCESSORY BOX

Lift the lid to remove the accessories.

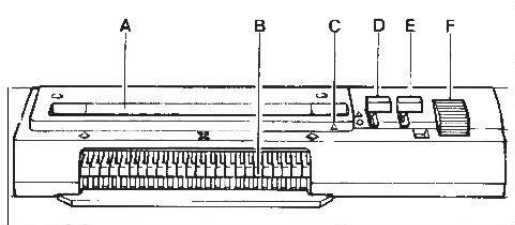

3. PATTERN CARD PANEL

- A - Punch Card Insertion Slit
- B - Touch Levers
- C - Card Row Number Indicator
- D - Stop Knob
- E - L Knob
- F - Punch Card Feeding Dial

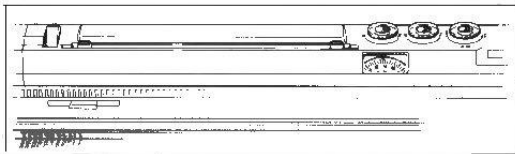

4. KNIT CONTOUR (RADAR)

See Knitting Manual.

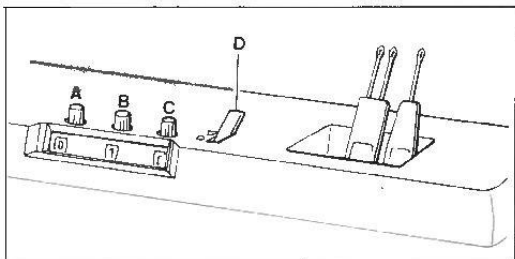

5. ROW COUNTER

To reset numbers, turn the knurled knobs "A", "B" and "C" to either direction.

- "D" - Row Counter Set Lever
 - ▼.....operating position
 -locked position

6. TOOL HOLDER

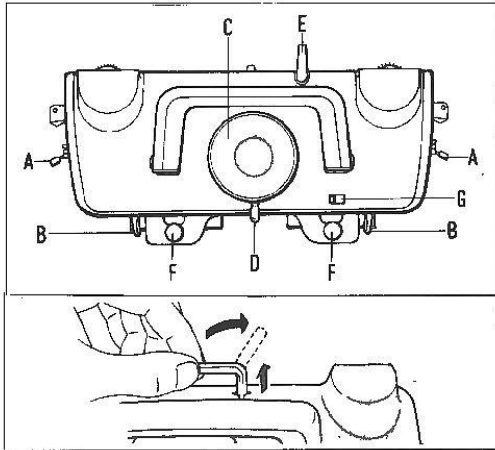
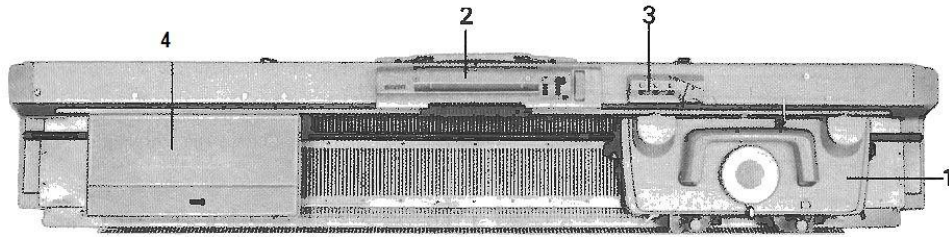

1. CARRIAGE

- A - Side Levers
- B - Russel/Front Levers
- C - Stitch Dial
- D - Cam Lever
- E - Row Counter Triper*
- F - Arm Nuts
- G - Release Lever

* To engage the Row Counter Triper with the Row Counter, lift it and point it towards the Row Counter. To disengage the Row Counter Triper, lift it and turn it to the side.

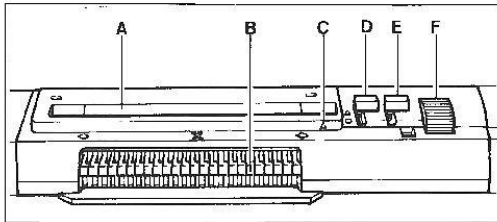

2. PATTERN CARD PANEL

- A - Punch Card Insertion Slit
- B - Touch Levers
- C - Card Row Number Indicator
- D - Stop Knob
- E - L Knob
- F - Punch Card Feeding Dial

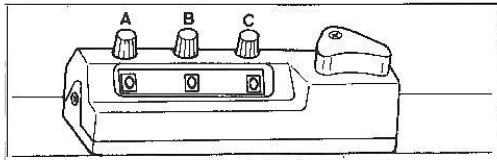

3. ROW COUNTER

To reset numbers, turn the knurled knobs "A", "B" and "C" to either direction.

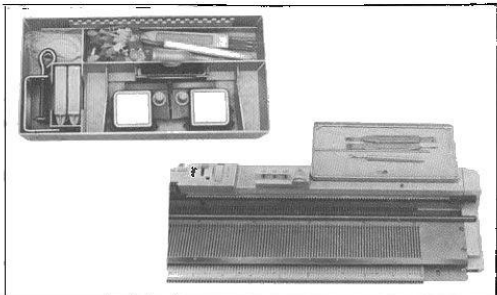

4. ACCESSORY BOX

Lift the Accessory Box and remove it from the Knitter.

5. Use the Accessory Box Lid as an accessory tray by fitting it onto the pin on the right side of casement.

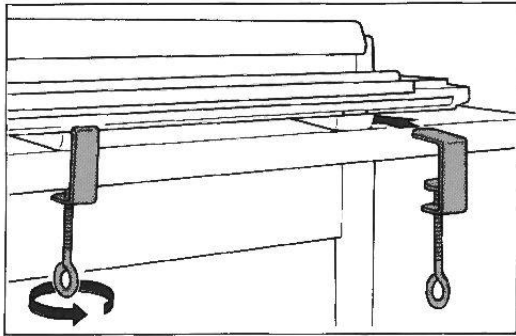

CLAMP

Insert the Clamps into the slots at the bottom of Needle Bed.

Fasten the Clamps by turning screws in the arrowed direction.

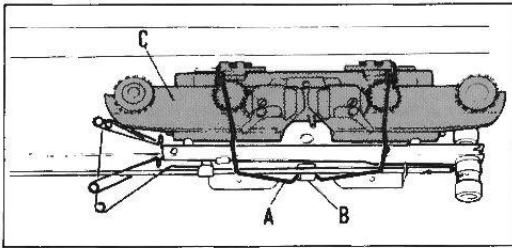

ARM

Release the wire spring "A" from holding bracket "B" located inside the Top Cover and remove the Arm "C".

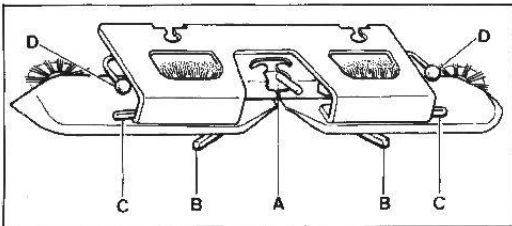

- A - Yarn Feeders
- B - Tuck Nobs
- C - Weaving Knobs
- D - Weaving Yarn Holders

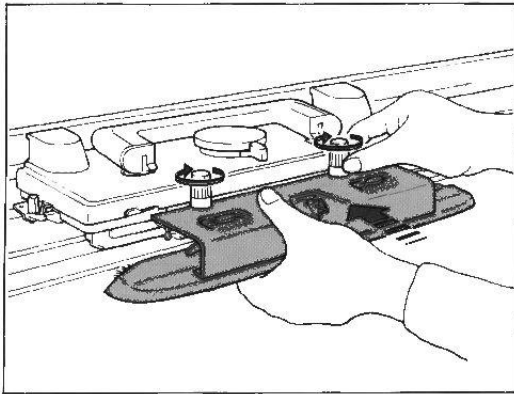

Insert the Arm under the two Arm Nut screws.

Push the Arm as far as it will go and tighten the Arm Nuts firmly by turning them in the arrowed direction.

Do not attach this Arm to the Lace Carriage.

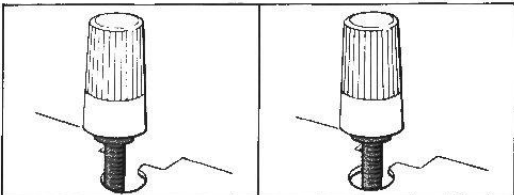

Ensure that the Arm Nuts fit correctly into the cut-out of the Arm.

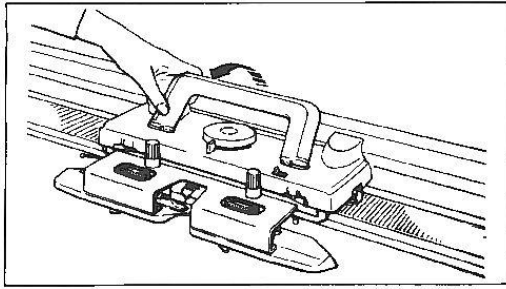

Raise the Carriage Handle.

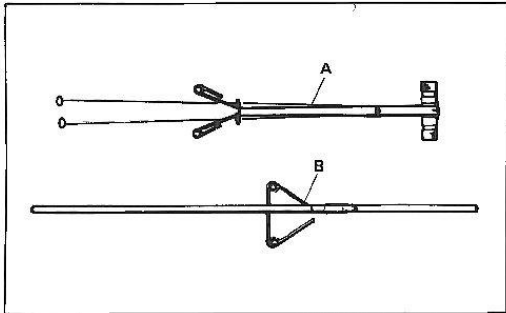

AUTO TENSION

Remove the Auto Tension "A" and Yarn Rod "B" from the inside of the Top Cover.

- ① Turn the two Tension Springs "C" until they snap into position.
- ② Insert the short bent end of the Yarn Rod "D" into the left side handle bracket socket "E".
- ③ Raise the Tension Guide.
- ④ Place the Auto Tension onto the Yarn Rod.

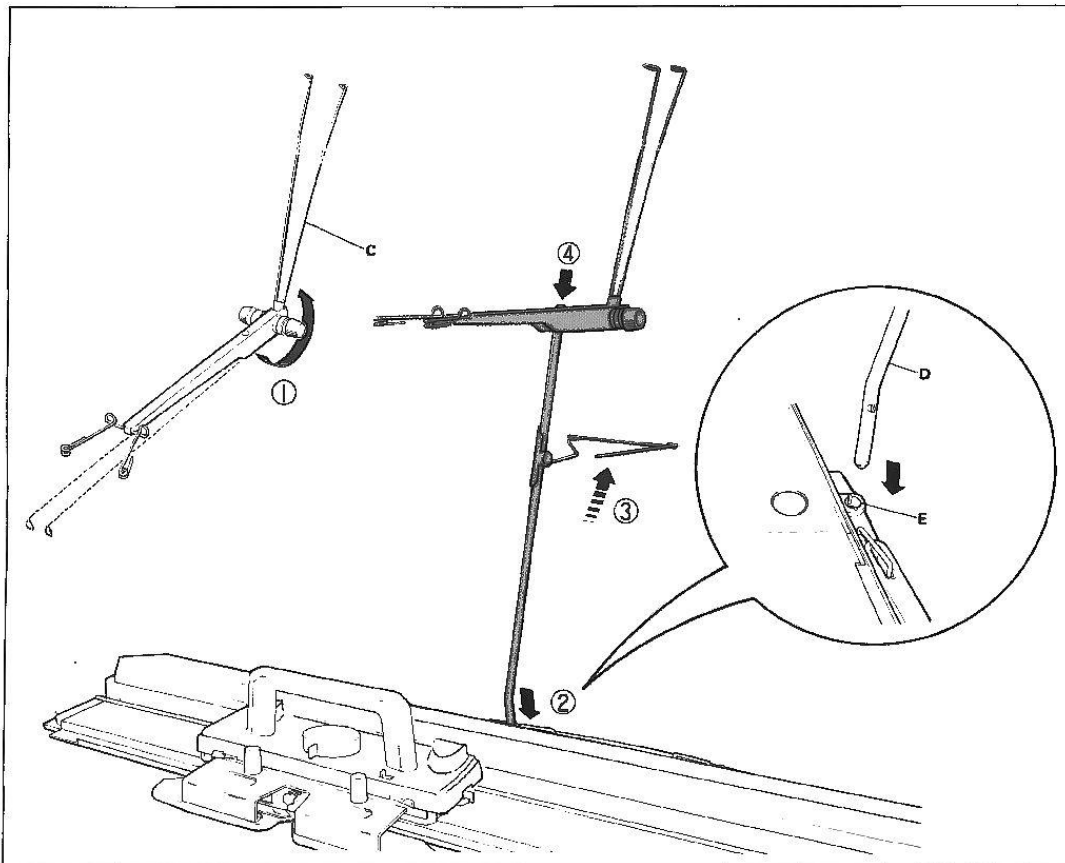

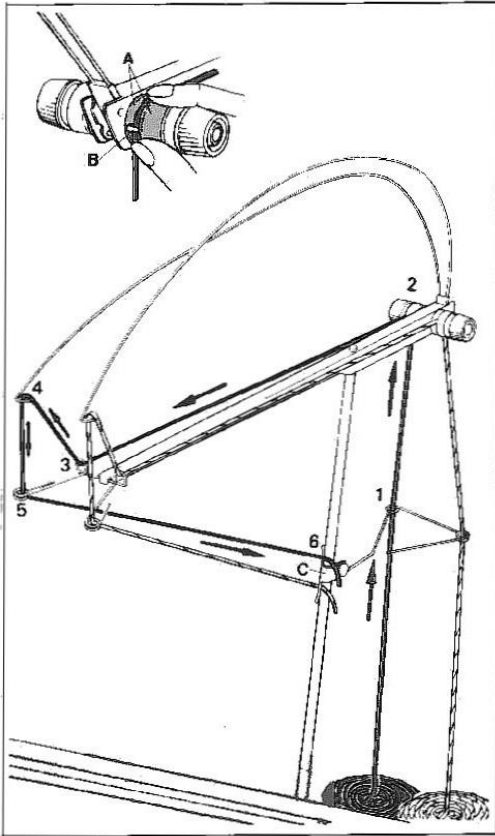

THREADING AUTO TENSION WITH TWO COLOUR YARNS A, B

For practice, prepare TWO NEW BALLS OR CONES of different colour medium 4-ply yarns A, B and thread them as follows:—

MAIN YARN A

Thread the left side of Auto Tension as follows:—

1. through left Tension Guide eyelet,
2. between two Tension Discs "A" and under the copper colour Guide Pin "B",
3. through left yarn guide eyelet,
4. through left Tension Spring eyelet,
5. through left yarn guide eyelet.

Pull the yarn end and hook it in the upper Yarn Clip "C".

SECOND YARN B

Thread the second yarn into the right side of Auto Tension in the same manner as you threaded the main yarn into the left side of the Auto Tension.

Hook the yarn end in the lower Yarn Clip.

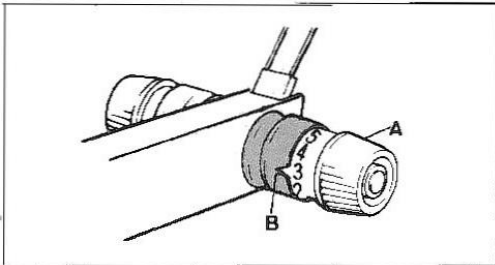

ADJUSTING TENSION DIAL

Adjust the Tension Dial according to type of yarn as guided below by turning the Tension Dial "A" until a required number corresponds to the < shape cut-out "B".

In this instance, 3 is suitable.

Cotton or nylon thread	6-7
Thin yarn (2-ply)	4-5
Medium yarn (4-ply)	3
Thick yarn	1-2

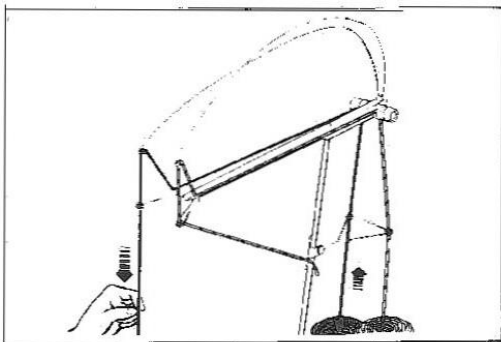

Incorrect threading of the Auto Tension will never assure success in knitting. Before going further, ensure that:

1. correct tension is given to yarn,
2. yarn comes out freely from yarn ball.

It is advisable to pull out a certain length of yarn of the ball before starting to knit.

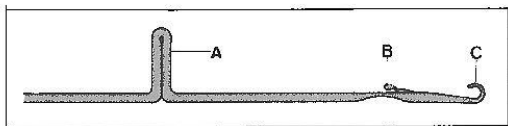

LATCH NEEDLE

- A - butt
- B - latch
- C - hook

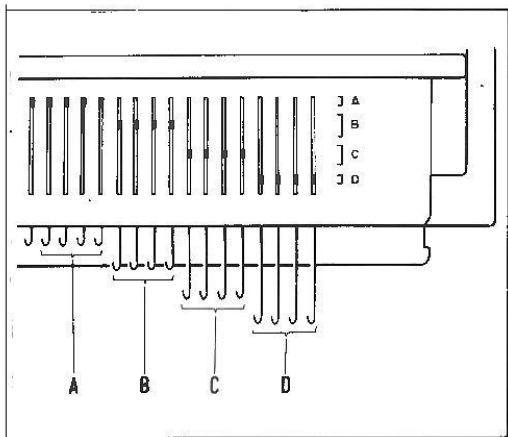

NEEDLE POSITIONS

On both left and right ends of the Needle Bed, the letters A, B, C and D associated with brackets "J" are engraved.

To operate the needles, align their butts within the brackets.

- A - needles do not knit.
- B - needles knit stockinet and stitch pattern.
- C - needles knit stockinet only.
- D - needles do not knit with Russel Levers at I. needles are knitted back to B position with Russel Levers at II.

NOTE: C AND D POSITIONS ARE NOT APPLICABLE TO MODELS 360/260L.

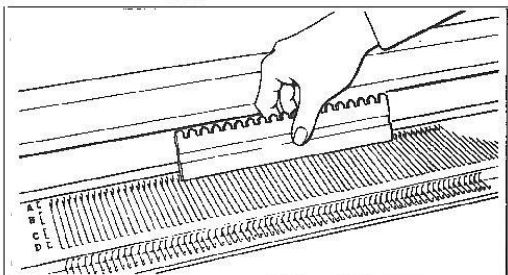

ALIGNING NEEDLES

Ensure all needles are in the "J" A non-knitting position. If some needles are not, using the straight edge of the Needle Pusher push the needles to "A" non-knitting position.

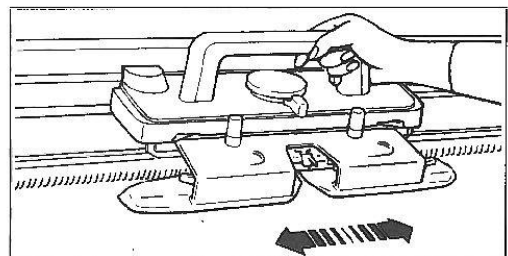

Slide the Carriage across the Needle Bed a few times to ensure it moves smoothly.

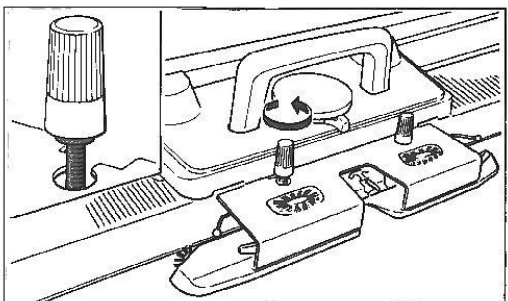

If the Carriage does not slide smoothly, ensure that the Arm Nut fits correctly into the cut-out of the Arm.

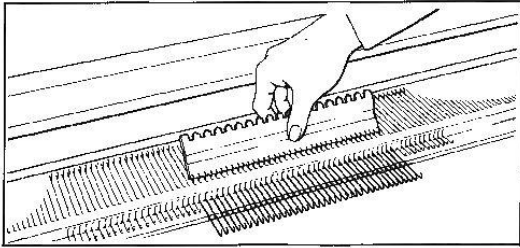

TO CAST ON

Push up 35 needles on the right and left side of centre (0), 70 needles in total, from A position to D using the Needle Pusher.

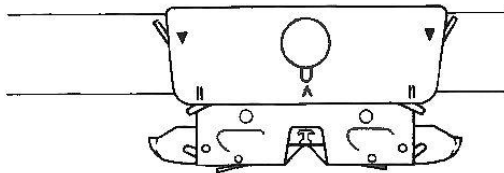
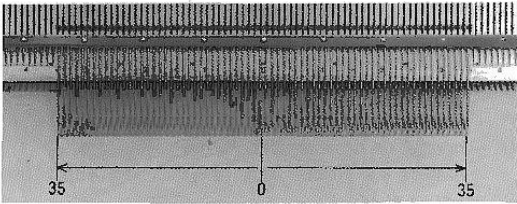

SETTING CARRIAGE

- Stitch Dial 5
- Cam Lever A
- Side Levers (left and right) ▼
- Russel Levers (left and right) II
- Weaving Knobs (left and right) ○
- Tuck Knobs (left and right) ○

Slowly move the Carriage across the Needle Bed until it has passed all the needles.

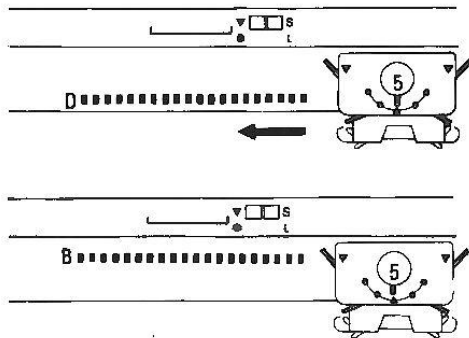

The needles are aligned in B position. Place the Carriage at the right side.

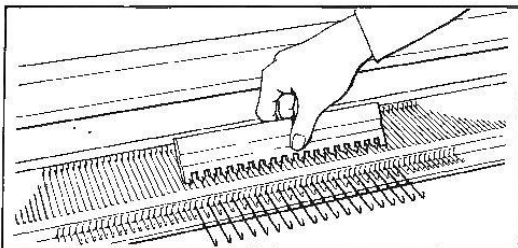

Using the Needle Pusher, push every 2nd needle from B to D position.

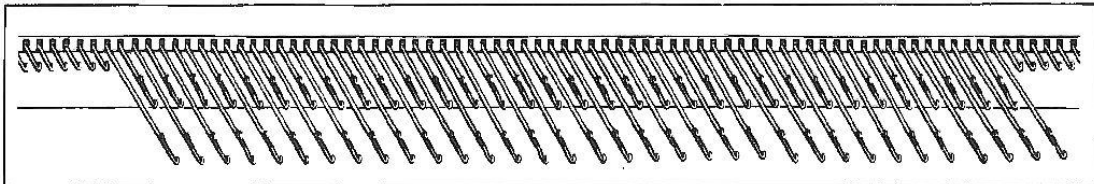

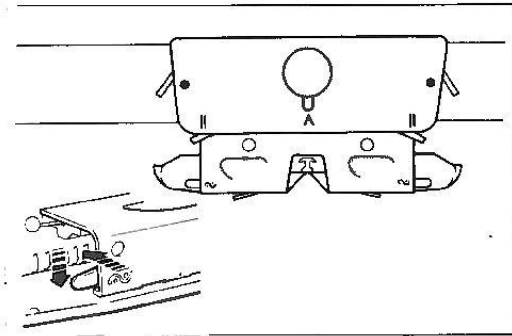

Both Side Levers.....●
 Both Weaving Knobs.....●

To set the Weaving Knob to ●, slightly push it forward, it will drop into position.

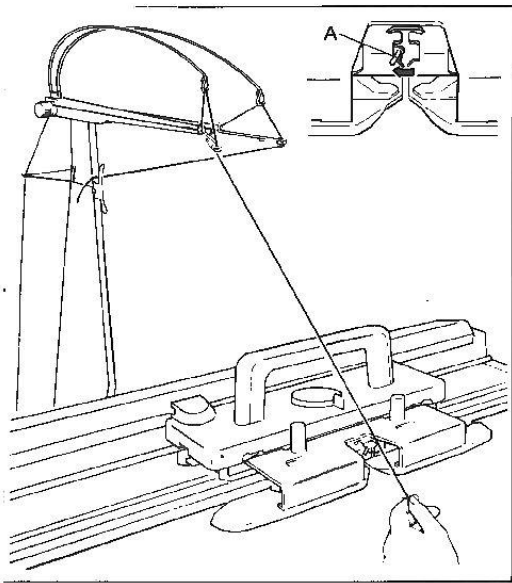

Open Yarn Feeder by moving the Yarn Feeder Gate "A" to the left.

Remove the main yarn end from lower Yarn Clip and bring it to the Yarn Feeder.

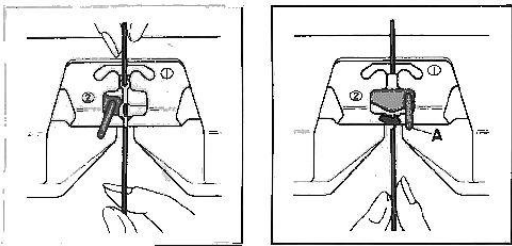

Hold the yarn with both hands and slide it into the Yarn Feeder.

Close the Yarn Feeder by moving the Yarn Feeder Gate "A" to the right.

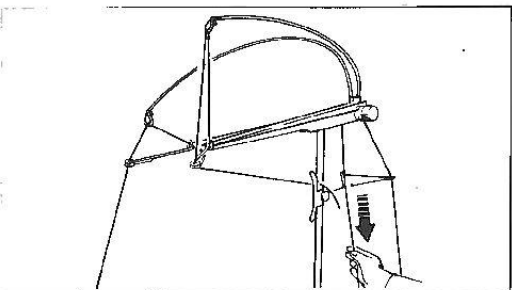

Hold yarn end beneath the Arm and eliminate slack yarn by pulling the yarn down at the back of Yarn Rod until the Tension Spring is nearly in a horizontal position.

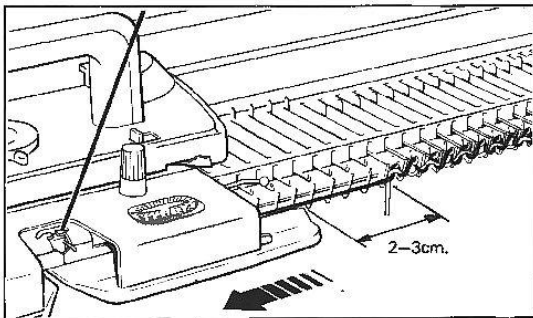
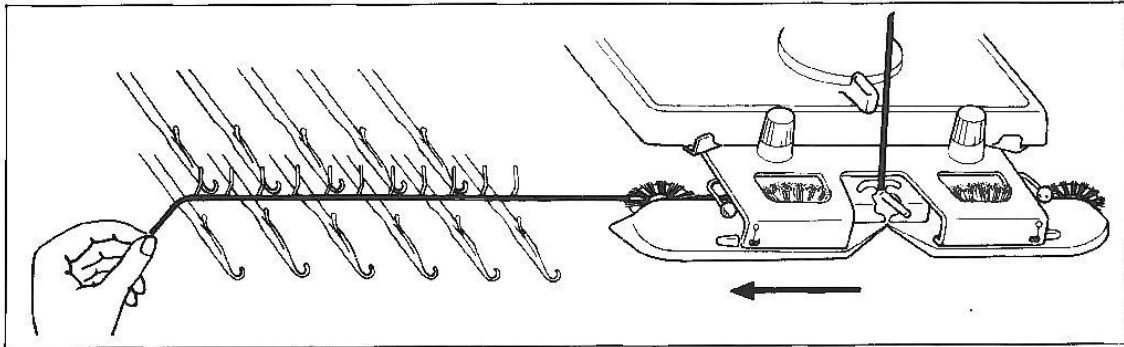

Pull yarn approximately 40cm, and extend it from underneath the Plastic Round Brush Cover in the Arm and lay it across all needles in D position.

Hold the yarn end at the left side of the needles.

Slowly move the Carriage from right to left until it has passed all the needles, knitting 1 row.

Ensure that the Arm has passed the last knitted needle by approximately 2-3cm. before knitting the next row.

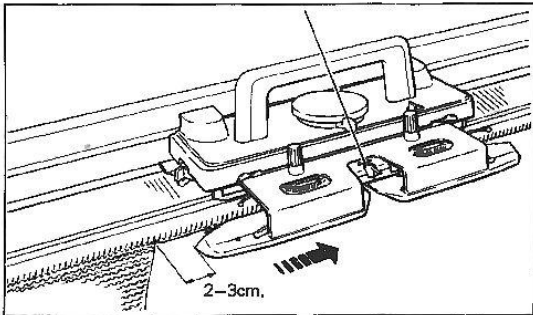

Knit 3 rows.

Ensure that the Arm has passed the last knitted needle by approximately 2-3cm. before knitting the next row.

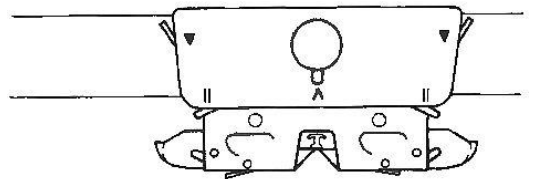

Both Side Levers.....▼
Both Weaving Knobs.....○

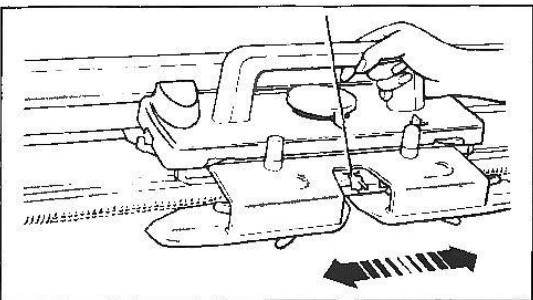

Knit 20 rows.

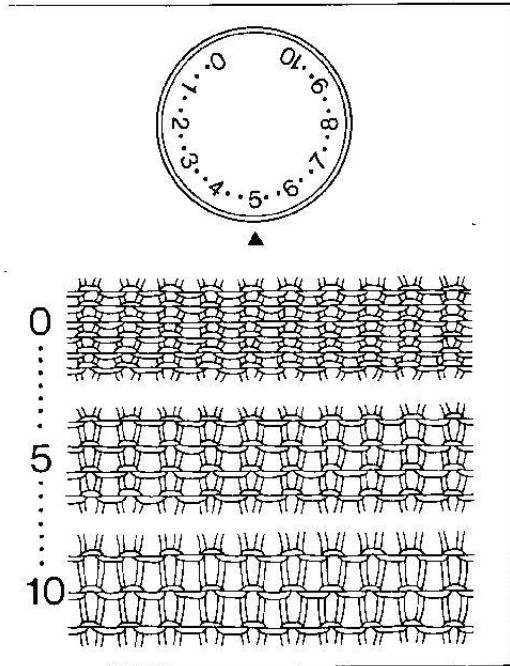

LEARNING ABOUT STITCH SIZE AND YARN

STITCH DIAL

Ensure that the correct Stitch Dial number is always selected for the yarn you will select.

Stitch Dial regulates the size of a stitch. When the Stitch Dial is set to 0, the tightest stitch size is obtained. (smallest stitch)

When the Stitch Dial is set to 10, the loosest stitch size is obtained. (largest stitch)

To select a number, turn the Stitch Dial until the required number or dot corresponds to ▲.

If the tension is too tight – it will be difficult or even impossible to knit, you will use more yarn and waste money – your garment will be hard and uncomfortable to wear.

If the tension is too loose – your garment will have no shape or will very soon lose its shape.

For practice, continue to knit with different Stitch Dial numbers as follows:–

1. with the Stitch Dial number 3, knit 10 rows – tightest stitch size is obtained.
2. with the Stitch Dial number 9, knit 10 rows – loosest stitch size is obtained.

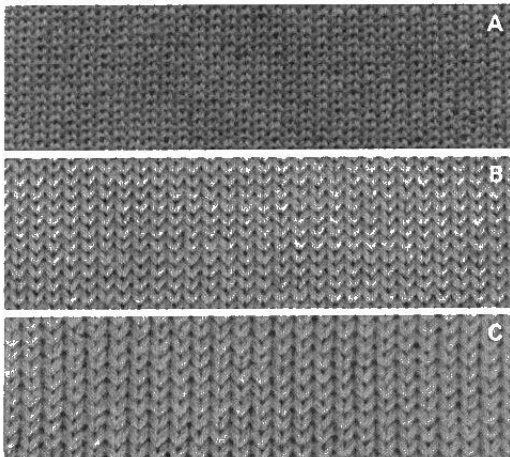

STITCH SIZE AND STITCH DIAL NUMBER FOR A YARN

- ▲ – Stitch Dial at 1 with yarn ② (2-ply)
- – Stitch Dial at 5 with yarn ⑤ (4-ply)
- – Stitch Dial at 9 with yarn ⑥ (thick)

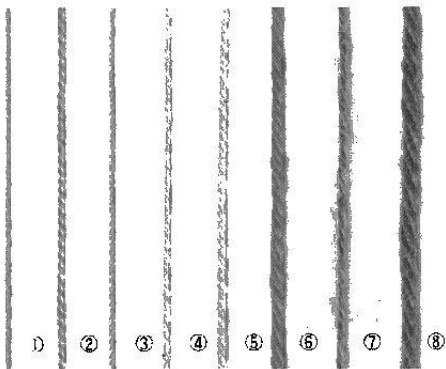

Type of yarn	Stitch Dial
① Cotton thread	2 – 3
② Thin yarn (2-ply)	2 – 3
③ Summer yarn	3 – 4
④ Light yarn (3-ply)	3 – 5
⑤ Medium yarn (4-ply)	4 – 6
⑥ Thick yarn	6 – 9
⑦ Mohair (every second needle)	8 – 10
⑧ Very thick yarn (every second needle)	6 – 9

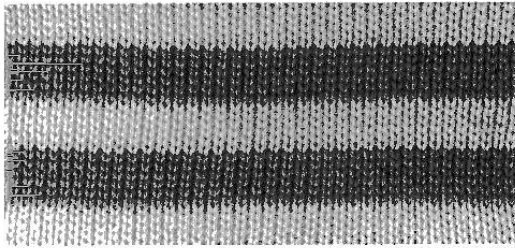

KNITTING STRIPE PATTERN

For practice, continue to knit stripe pattern using two different colour yarns alternately in the Yarn Feeder ①.

Stitch Dial.....5

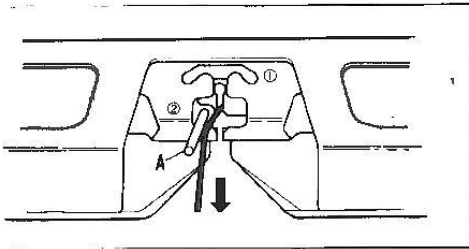

Open the Yarn Feeder by moving Yarn Feeder Gate "A" to the left.

Remove main yarn from the Yarn Feeder.

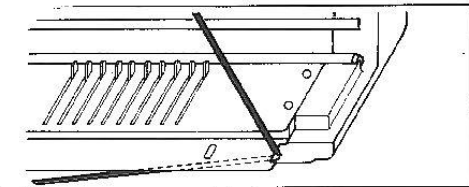

Place the main yarn at the cut-out "B" at the side of Needle Bed.

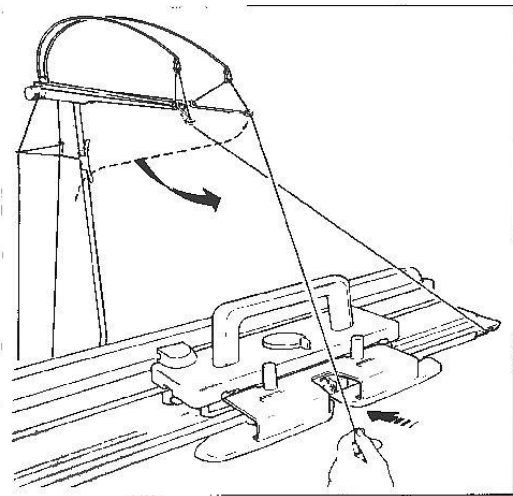

Remove the second colour yarn from the lower Yarn Clip and pull it down towards the Yarn Feeder.

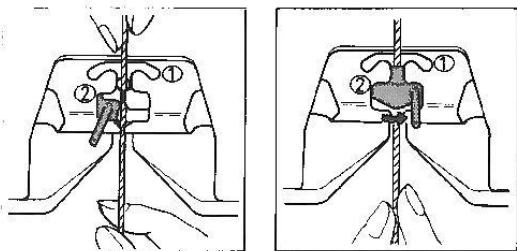

Hold the second colour yarn with both hands and slide it into the Yarn Feeder.

Close the Yarn Feeder by moving the Yarn Feeder Gate to the right.

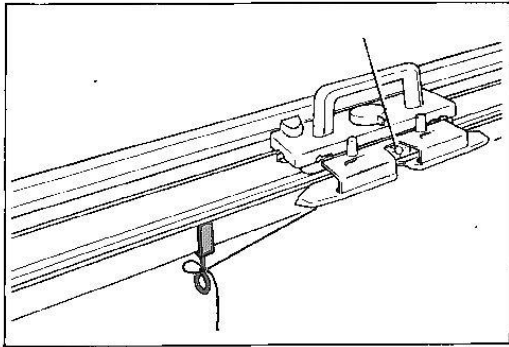

Fasten the yarn end to either Clamp.

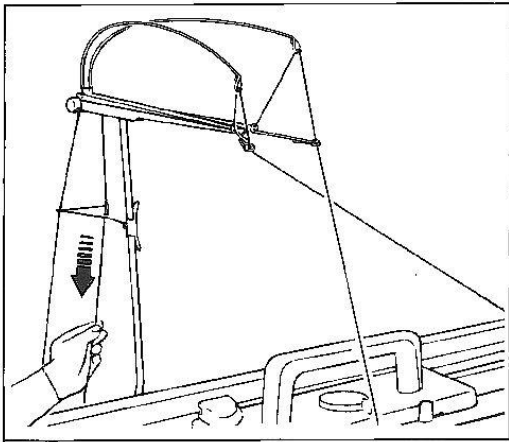

Eliminate slack yarn by pulling the yarn down at the back of Yarn Rod until the Tension Spring is nearly in the horizontal position.

For practice, knit 6 rows.

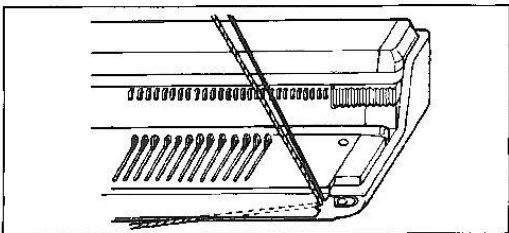

Remove the second colour yarn from Yarn Feeder ① and place it at the cut-out as done for main yarn.

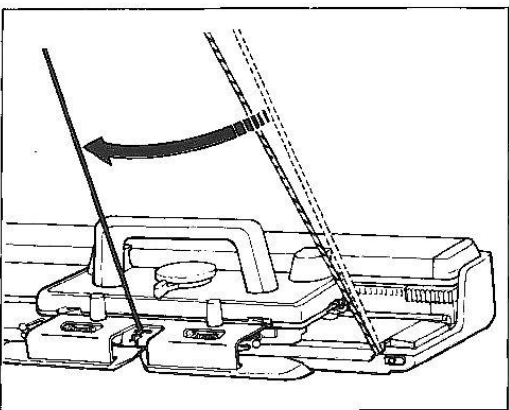

Remove the main yarn from the cut-out and slide it into the Yarn Feeder ① with both hands.

Eliminate slack yarn.

Knit 6 rows.

By using two yarns alternately, stripe pattern can be knitted.

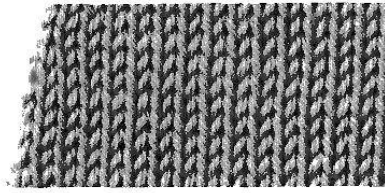

DECREASING 1 STITCH

You can decrease 1 stitch on both sides of the row.

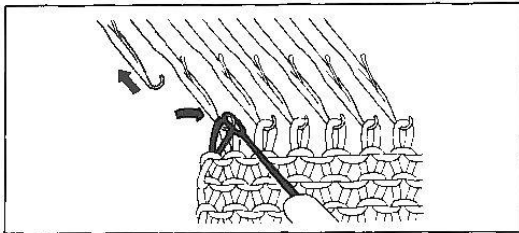

Using the Transfer Tool, transfer the end stitch onto its adjacent needle.

Push back the empty needle to A position.

For practice, knit more rows decreasing 1 stitch on both sides of the row.

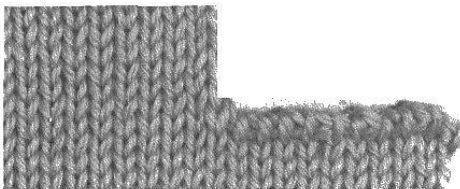

DECREASING MULTIPLE STITCHES

You can only decrease on the Carriage side.

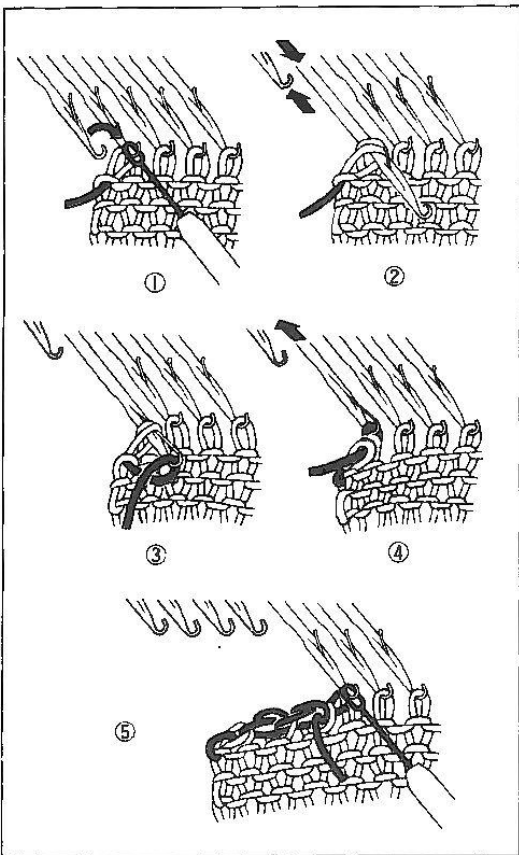

① On the Carriage side, hold the fabric towards the Knitter.

Transfer the end stitch to the adjacent needle.

② Push the empty needle to A position.

Push the second needle to D position until both stitches are behind the latch.

③ Lay yarn from right to left on the open hook of the needle.

④ Hold yarn slightly down and push the needle back to B position.

The two stitches slip off the needle.

⑤ Continue this procedure until the required number of stitches have been decreased.

Place the last decreased stitch onto its adjacent needle.

For practice, decrease four stitches on both sides.

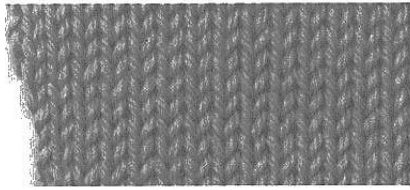

INCREASING 1 STITCH

You can increase 1 stitch at a time on the Carriage side.

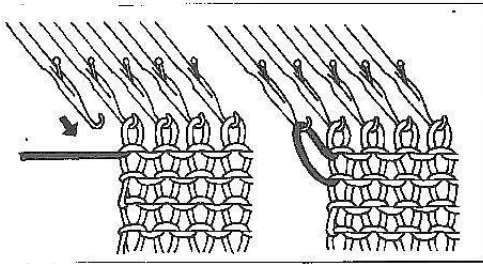

Push 1 needle on the Carriage side from A to B position.

For practice, knit more rows increasing 1 stitch on the Carriage side on the row.

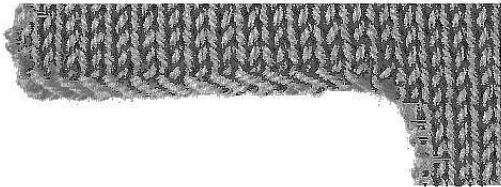

INCREASING MULTIPLE STITCHES

You can only increase on the Carriage side.

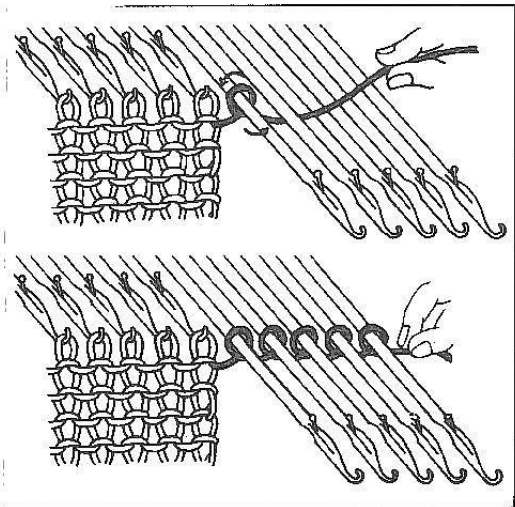

Carriage is on the right side.

1. Pull some yarn from the Yarn Feeder.
2. Push the required number of needles from A to D position.
3. Wind yarn loosely around the empty needles in the anti-clockwise direction.
4. Push loops against sinker posts.
5. Eliminate slack yarn.
6. Continue knitting.

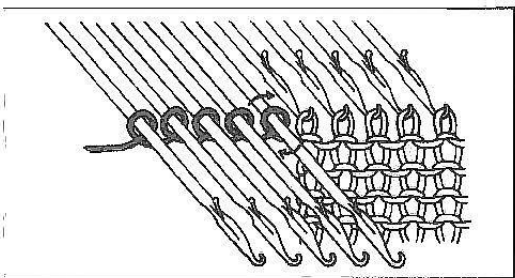

When the Carriage is on the left side, wind yarn around the needles in the clockwise direction.

For practice, increase five stitches on both sides.

REMOVING KNITTED FABRIC

without closing end stitches

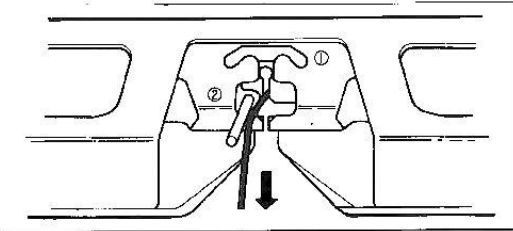
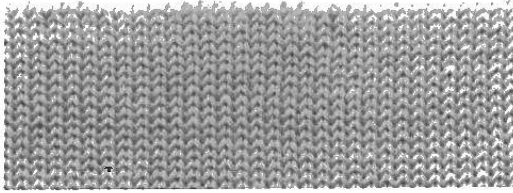

Open the Yarn Feeder and remove yarn.

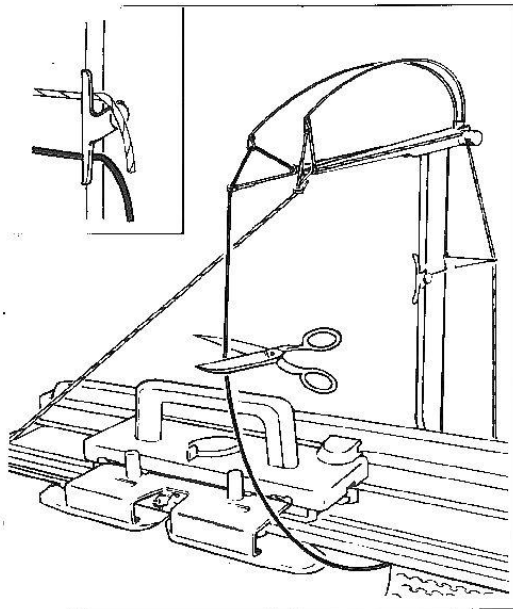

Break the main yarn and hook its top end onto the lower Yarn Clip of the Yarn Rod.

Break the second yarn and hook its top end onto the upper Yarn Clip.

Let both bottom yarn ends hang loosely on the side of the fabric.

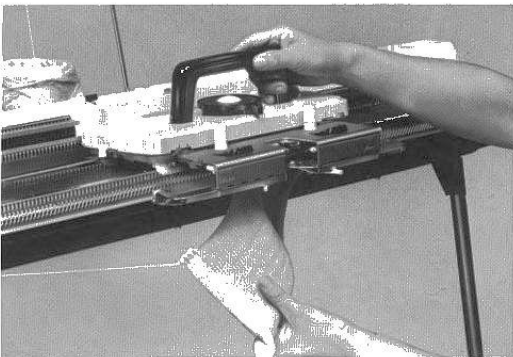

Carriage Lever.....A

Move Carriage across the fabric.

The fabric will come off the needles.

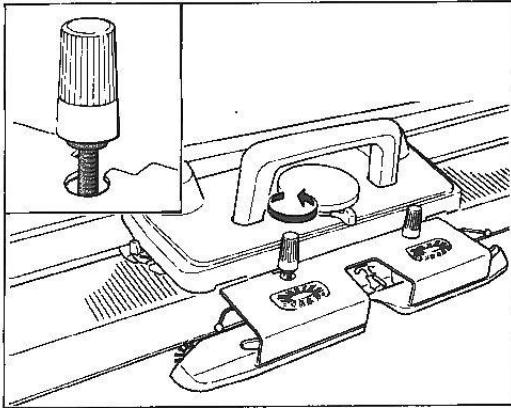

IMPORTANT

IF YOU HAVE ANY DIFFICULTY IN KNITTING THE FIRST ROW, ENSURE THAT:

Arm is attached to the Carriage correctly.

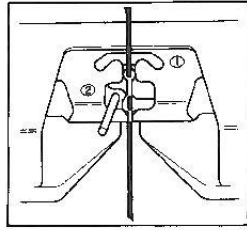
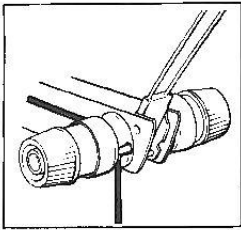

Yarn is threaded correctly through the Auto Tension and Yarn Feeder.

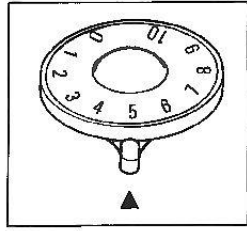
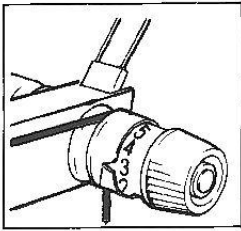

Tension Dial and Stitch Dial are set correctly.

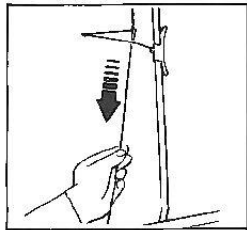
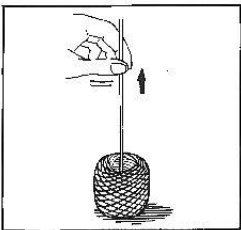

Yarn is wound correctly.

Slack yarn is eliminated and Tension Spring is nearly in a horizontal position.

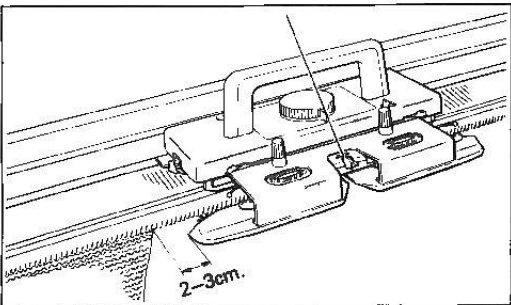

Arm has passed the last knitting needles by approximately 2-3cm. before knitting the next row.

PATTERN KNITTING WITH MAIN CARRIAGE

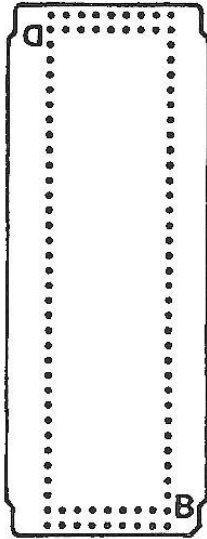
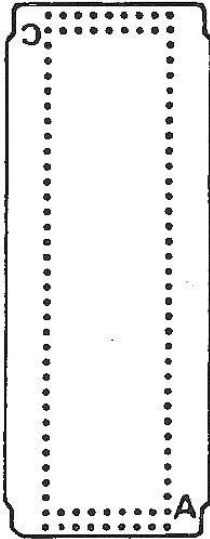

STANDARD PUNCH CARDS FOR MAIN CARRIAGE

Twenty Punch Cards are numbered No.1 – No.20.

Each Punch Card can be used in four different ways and is marked "A", "B", "C" and "D"

"A" indicates the basic pattern.

If "B", "C" or "D" side of the Punch Card is inserted into the Pattern Card Panel, direction of pattern can be changed.

IMPORTANT Do not fold or bend the Card.

With the Punch Cards, the following patterns can be produced.

Card No.	A	B	C	D	E	F	G	H
1	○			○	○	○	○	
2	○		○	○	○	○	○	○
3	○		○	○	○		○	○
4	○		○	○	○		○	○
5	○	○						
6-03	○	○						
7	○		○	○	○	○	○	
8	○		○	○			○	
9	○		○	○			○	
10	○		○	○				
11	○		○	○			○	
12	○		○	○				
13	○							
14	○		○			○	○	
15	○					○		
16	○						○	
17	○					○		
18	○		○	○			○	
19-03	○	○						
20	○							

- A KNOT-IN/FAIR ISLE
- B SINGLE MOTIF
- C SLIP STITCH PATTERN
- D TUCK STITCH PATTERN
- E TUCK LACE
- F PUNCH LACE
- G WEAVING
- H WEAVING LACE

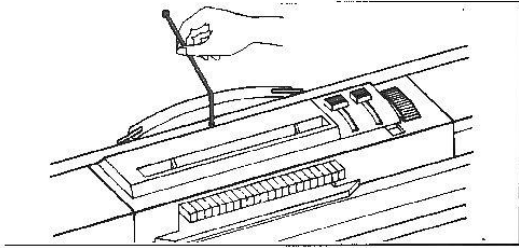

INSERTING PUNCH CARD

Prepare two Card Snaps and the Punch Card.

For Model 240K/L, remove the Card Guide from the Accessory Box and insert it vertically into the receiving hole at the back of the casement.

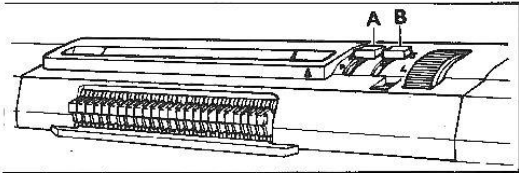

Stop Knob "A"▼
L Knob "B"S

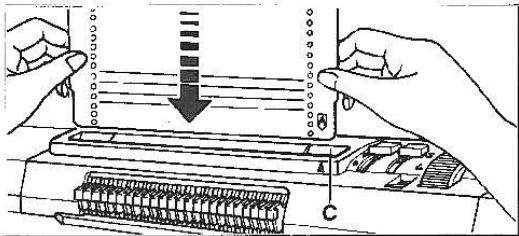

Holding the Punch Card straight with the letter **A** on the bottom right hand corner facing you, insert it into Punch Card Insertion Slit "C" and push it down slightly.

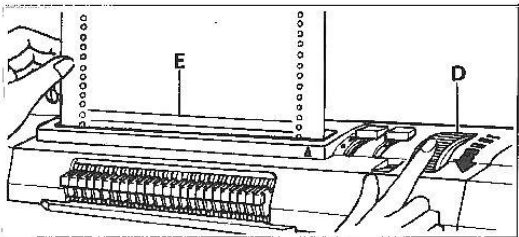

Turn the Punch Card Feeding Dial "D" towards you and at the same time check that the red horizontal lines "E" on the Punch Card are paralleled with the Punch Card Insertion Slit.

To advance the Punch Card, turn the Punch Card Feeding Dial towards you.

To return the Punch Card, turn the Punch Card Feeding Dial towards the side away from you.

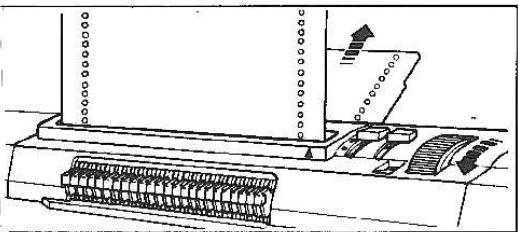

Continue turning the Punch Card Feeding Dial until the Card end comes out from the back of Pattern Card Panel and the front and back edges of the Card are in line.

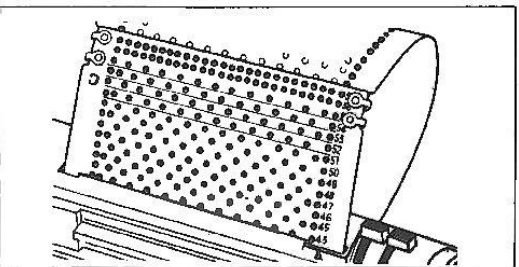

Overlap the ends of the Punch Card with the letter "C" on the top left side of the Card.

Line up the 2 holes on each side.

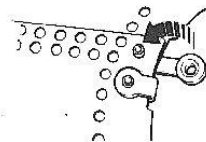

Insert the Card Snap and join the Card ends by pressing the Snap together.

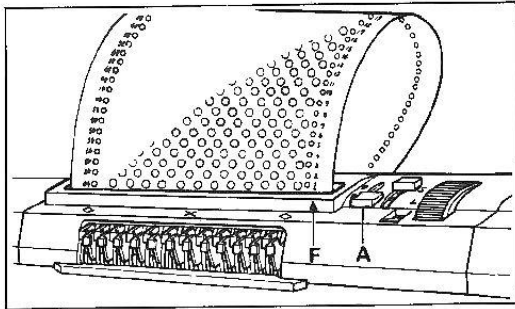

Turn the Punch Card Feeding Dial until Card memory number 1 reaches above the triangle mark "F" on Pattern Card Panel.

No. 1 is always the beginning of a pattern.

Stop Knob "A".....●

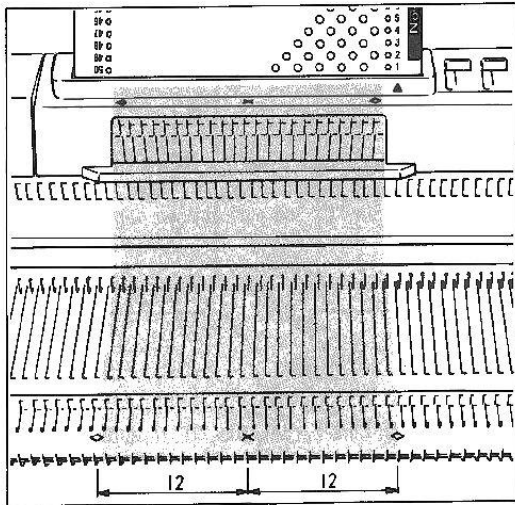

On the front of the Pattern Card Panel and from edge of Needle Bed are markings X and ◇.

X – indicates the centre of a pattern.
◇ – indicate width of pattern.

Between two ◇ markings are 24 needles.

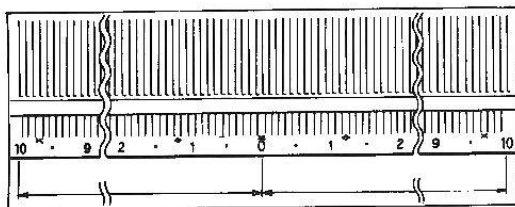

The numbers 0–100 on the left and right side of centre(0) indicate the number of needles.

The pattern of the Punch Card is produced on the needles on the left and right sides of centre(0).

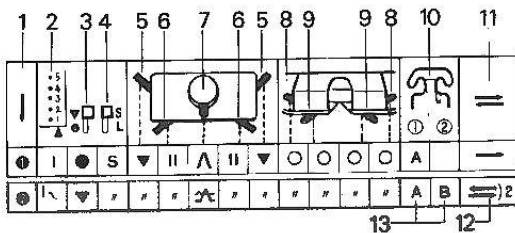

READING OPERATION TABLE

- | | |
|-----------------------|---|
| 1 – Order | 10 – Yarn Feeder ① and ②. |
| 2 – Card Memor Number | Yarn Feeder ② column also includes Weaving Yarn Holder or Platting Yarn Feeder. |
| 3 – Stop Knob | |
| 4 – L Knob | |
| 5 – Side Levers | |
| 6 – Russel Levers | 11 – Knitting direction. |
| 7 – Cam Lever | 12 – The required number of rows should be knitted. |
| 8 – Weaving Knobs | |
| 9 – Tuck Knobs | 13 – A, B and C stand for different yarns. |

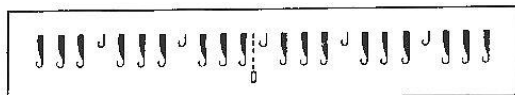

Needle arrangement



Point Cams M setting

CAUTION ON PATTERN KNITTING

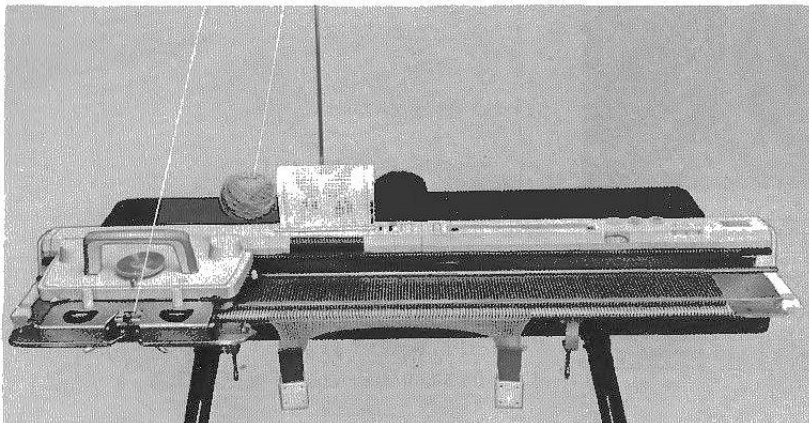

Before practicing pattern knitting, knit 9–10 rows of stockinet and place the Carriage at the left side of the Needle Bed.

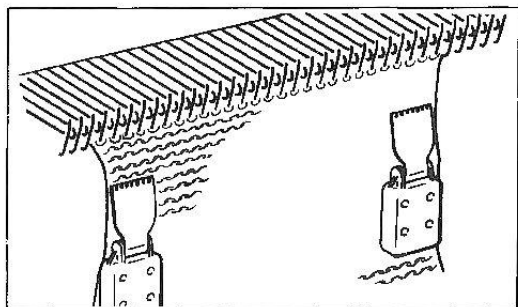

Always hook the Claw Weights at both edges of the knitting.

Move the Claw Weights up as knitting progresses.

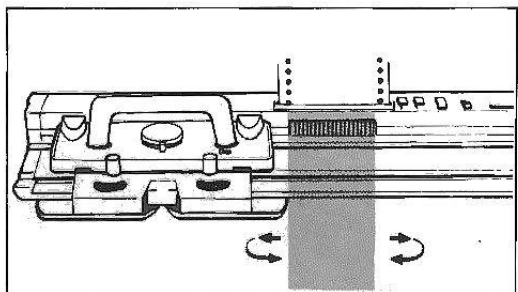

When moving the Carriage back and forth, ensure that the Carriage has passed the 24 needles corresponding to the Touch Levers "A".

Move the Carriage at an even speed.

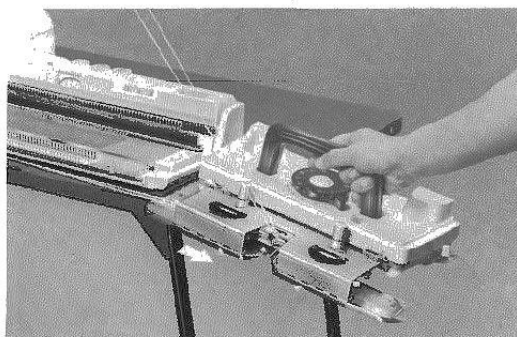

Do not remove the Carriage from the Needle Bed.

If the Carriage has been removed by accident, see page 68 for adjustment.

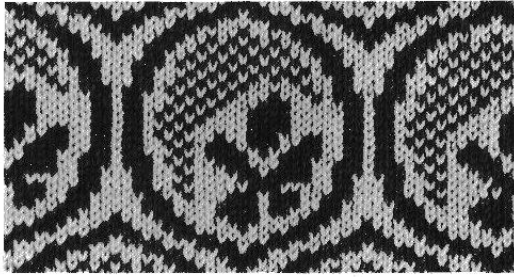

KNIT-IN (FAIR ISLE)

Punch Card No. 20-A

Insert the Punch Card.

Set the Controls as required in ORDER 1.

Knit 1 row from left to right.

Hang the Claw Weights at both edges of the knitting.

Set the Controls as required in ORDER 2.

Remove the second yarn end from the Yarn Clip and pull it down towards the Carriage.

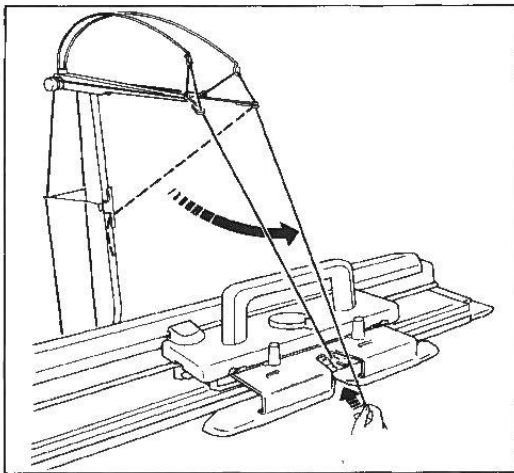
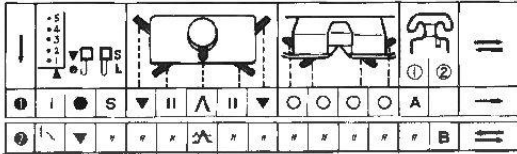

Insert the second yarn into the Yarn Feeder ②.

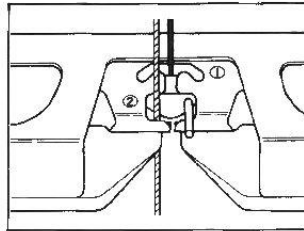

Fasten the yarn end to the Clamp.

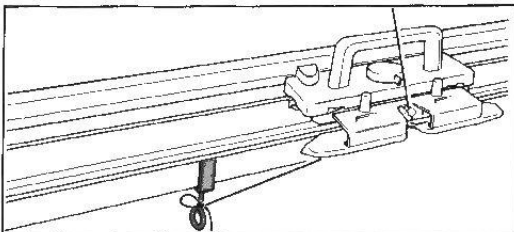

Eliminate slack yarn by pulling yarn down at the back of Yarn Rod until Tension Spring "A" is nearly in the horizontal position.

Knit the required number of rows.

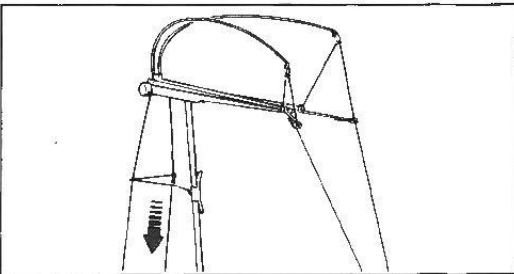

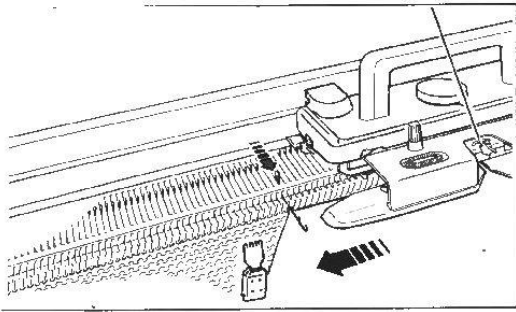

If the end stitches are not knitted perfectly, push one end needle on the Carriage side to D (or C in partial knitting) position before knitting the next row.

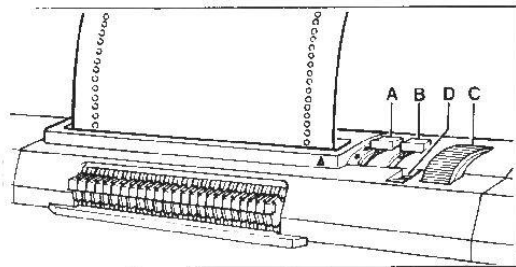

PATTERN CARD PANEL FUNCTION

STOP KNOB

When the Stop Knob "A" is set to ●, the Punch Card is locked and not advanced by the Punch Card Feeding Dial "C" and by the Carriage.

When the Stop Knob "A" is set to ▼, the Punch Card is free and advanced by the Punch Card Feeding Dial "C" and by the Carriage.

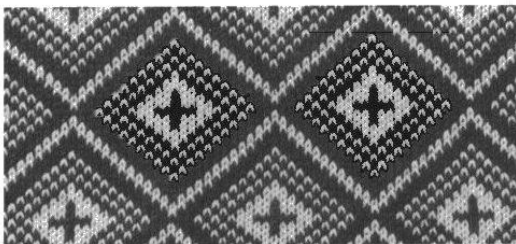

KNDB

When the L Knob "B" is set to S, the Punch Card is advanced every row as the Carriage moves and standard pattern is knitted.

When the L Knob is set to L, the Punch Card is advanced every second row as the Carriage moves, thus producing vertically expanded pattern.

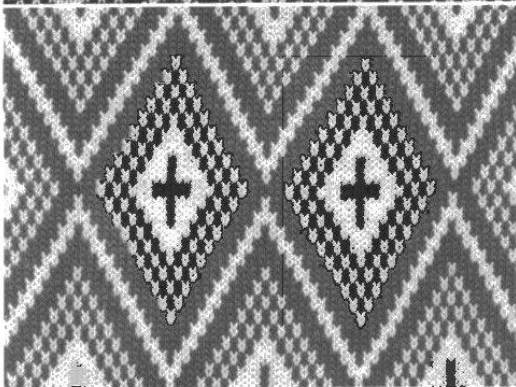

KNOB INDICATOR

Colours in the L Knob Indicator "D" alternate.

Blue.....the current row is repeated on the next row.

Red.....the Punch Card advances to the next row and a new pattern row is knitted.

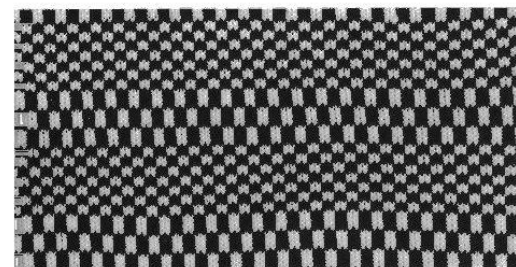

HINTS

This L Knob function is mostly used with KNIT-IN but can be used for other stitch types, if the Punch Card is suitable, such as WEAVING, SLIP STITCH PATTERN and PUNCH LACE.

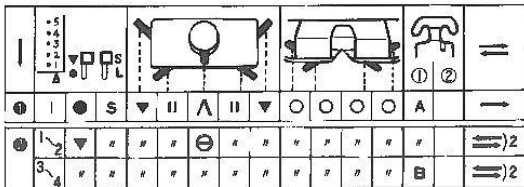
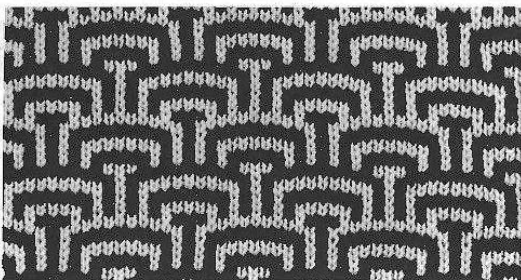
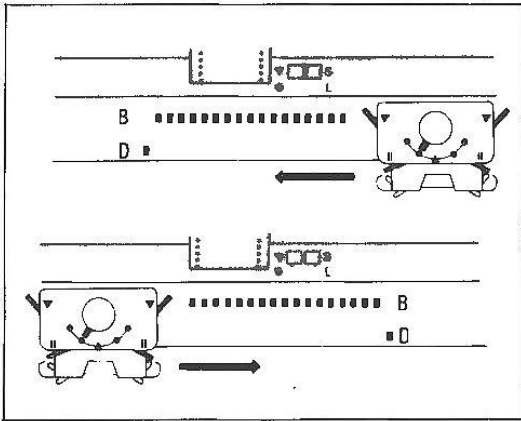
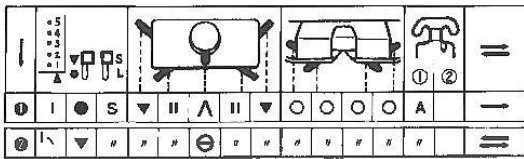
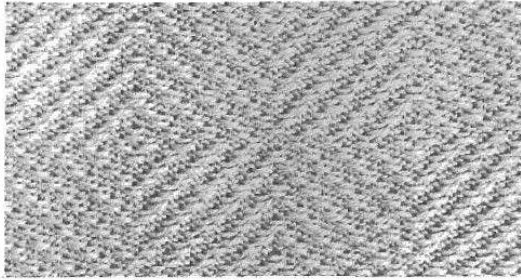

SLIP STITCH PATTERN

Punch Card No.18-A

Insert the Punch Card.

Set the Controls as required in ORDER 1.

Knit 1 row from left to right.

Hang the Claw Weights at both edges of the knitting.

Set the Controls as required in ORDER 2.

Set the Stitch Dial 1 number higher than that for stockinet as the fabric of slip stitch pattern is rather tight.

Push one end needle on the side opposite the Carriage to D (or C in partial knitting) position before knitting the next row.

Continue knitting by pushing the end needles on the side opposite the Carriage before knitting the next row.

SLIP STITCH PATTERN IN COLOUR

Punch Card No.10-A

Insert the Punch Card.

Set the Controls as required in ORDER 1.

Hang the Claw Weights at both edges of the knitting.

Knit 1 row from left to right.

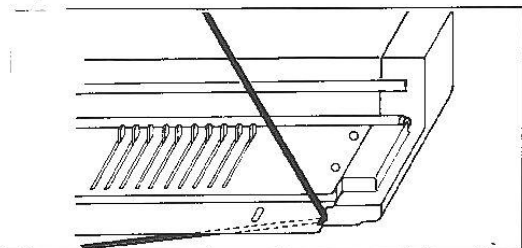

Remove main yarn from the Yarn Feeder and place it at the cut-out on the side of the Needle Bed.

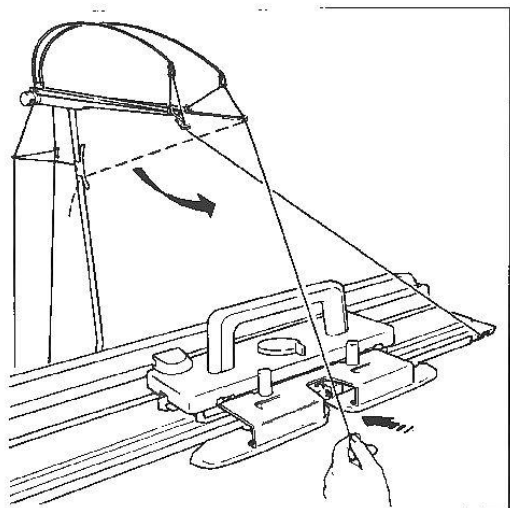

Remove second yarn from the Yarn Clip.

Insert second yarn into the Yarn Feeder ①.

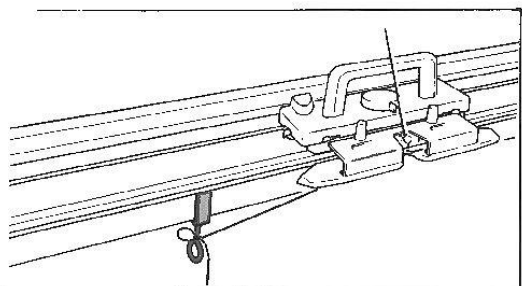
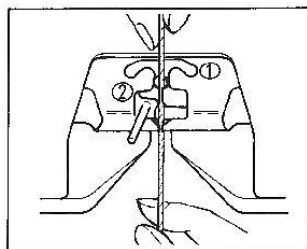

Fasten the yarn end to either Clamp.

Set the Controls as required in ORDER 2.

Set the Stitch Dial 1 number higher than that for stockinet as the fabric of slip stitch pattern is rather tight.

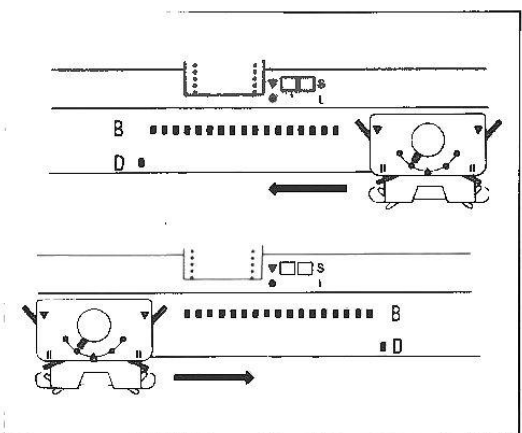

Push one end needle on the side opposite the Carriage to D (or C in partial knitting) position before knitting the next row.

Knit 2 rows with the second yarn.

Continue knitting by pushing the end needles on the side opposite the Carriage before knitting the next row.

Knit required number of rows using two yarns alternately.

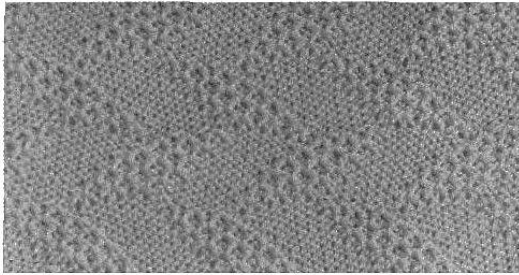

TUCK STITCH PATTERN

Punch Card No.12-A

Insert the Punch Card.

Set the Controls as required in ORDER 1.

Knit 1 row from left to right.

Hang the Claw Weights at both edges of the knitting.

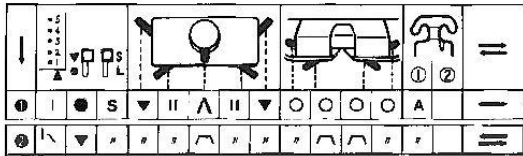

Both Tuck Knobs.....

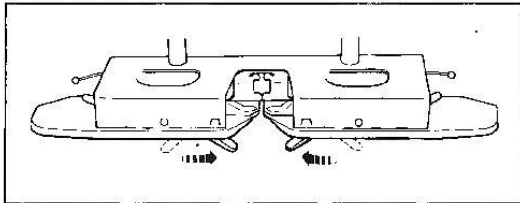

Set the other Controls as required in ORDER 2.

Knit the required number of rows.

If the edge stitches are not knitted perfectly, push up two end needles on the side opposite the Carriage to D (or C in partial knitting) before knitting the next row.

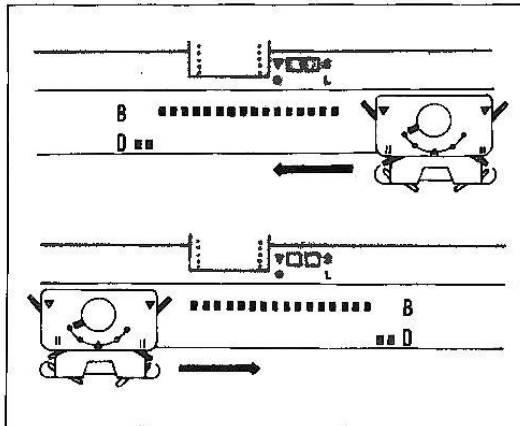

If the yarn easily entangles with the Round Brushes in the Arm, set the Yarn Separators at both sides of the knitting needles.

The yarn must pass over separators.

For instruction, see page 38, 39.

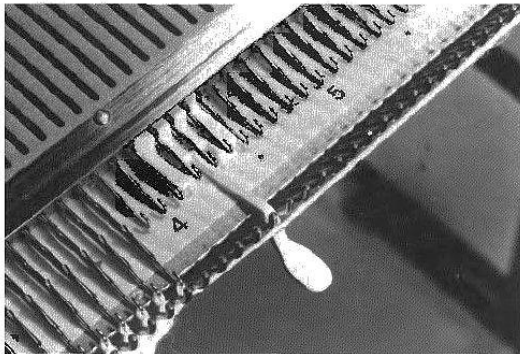

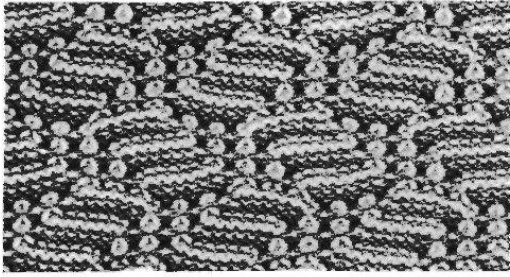

TUCK STITCH PATTERN IN COLOURS

Punch Card No.12--A

Insert the Punch Card.

Set the Controls as required in ORDER 1.

Knit 1 row from left to right.

Hang the Claw Weights at both edges of knitting.

①	5	S	L	=						
	4									
3	2	1	0	0	0	0	0	0	A	—
4	3	2	1	0	0	0	0	0	B	2

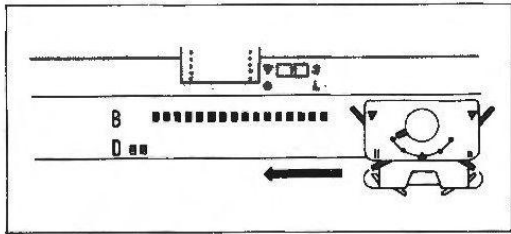

Both Tuck Knobs.....

Set the other Controls as required in ORDER 2.

Knit 2 rows.

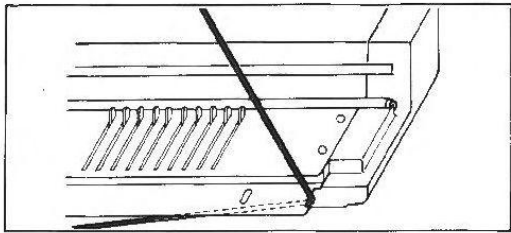

Remove main yarn from the Yarn Feeder ① and place it at the cut-out on the side of Needle Bed.

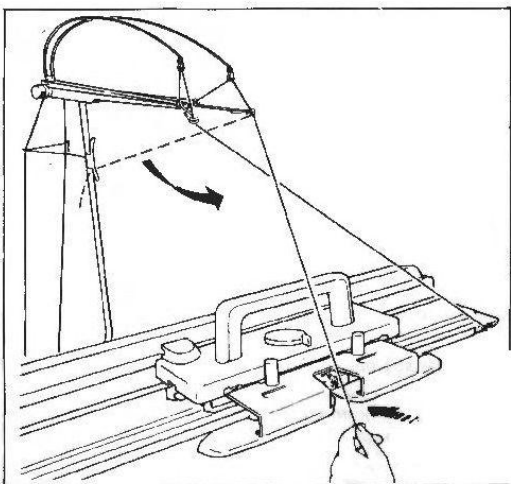

Insert second yarn into the Yarn Feeder ①.
For instructions, see page 28.

Knit 2 rows with second yarn.

Knit the required number of rows using two yarns alternately.

If the edge stitches are not knitted perfectly, see page 29.

If the yarn easily entangles with the Round Brushes in the Arm, see page 29.

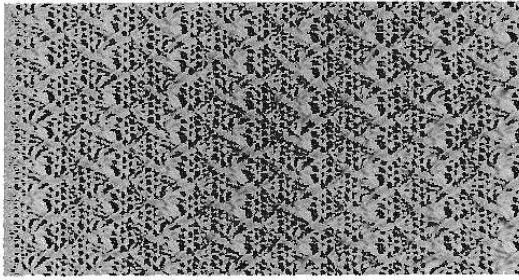

TUCK LACE

Punch Card No.3-A

This is a variation of tuck stitch pattern placing selected needles in A position.

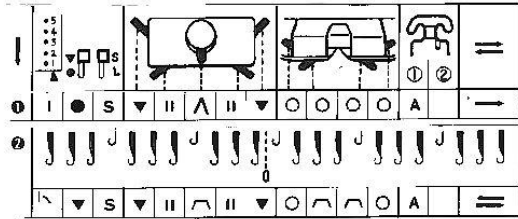

Insert the Punch Card.

Set the Controls as required in ORDER 1.

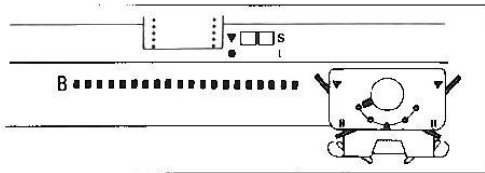

Knit 1 row from left to right.

Hang the Claw Weights at both edges of the knitting.

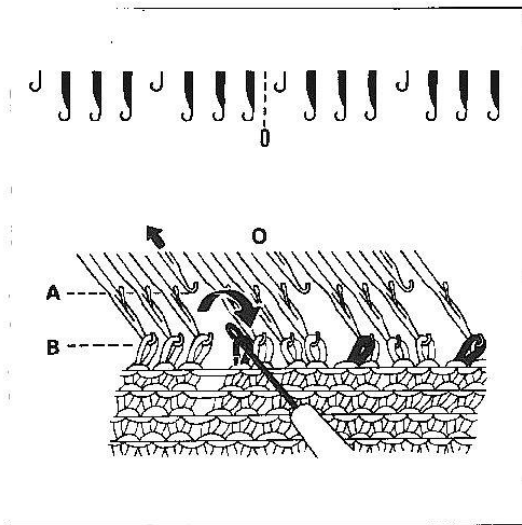

Transfer every fourth stitch to its adjacent needle starting at centre "O" on the Needle Bed as shown.

Push every fourth empty needle to A position.

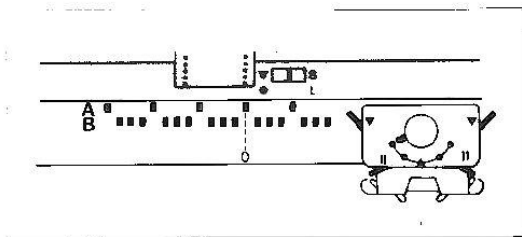

Set the Controls as required in ORDER 2.

Knit the required number of rows.

If the edge stitches are not knitted perfectly, see page 29.

If the yarn easily entangles around the Round Brushes in the Arm, see page 29.

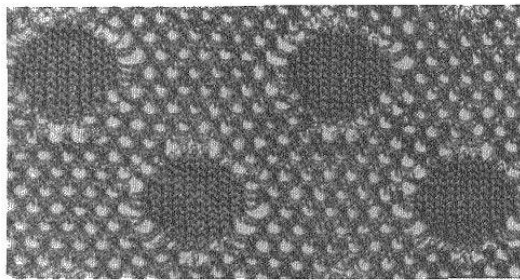

PUNCH LACE

Punch Card No.17-A

A fine transparent nylon thread is used with main yarn.

Insert the Punch Card.

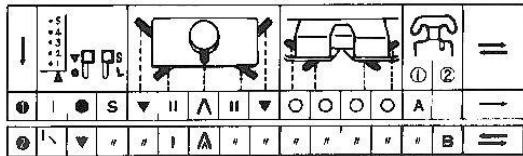

Set the Controls as required in ORDER 1.

Knit 1 row from left to right.

Hang the Claw Weights at both edges of the knitting.

Set the Controls as required in ORDER 2.

Cover spool of nylon thread with Stop Net (an optional accessory) or with a cut-piece of stocking.

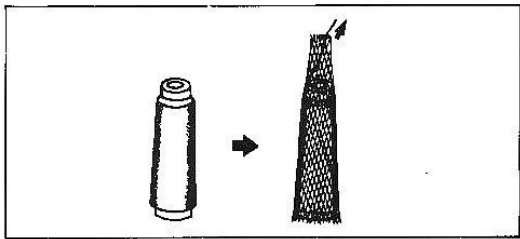

Thread nylon thread into one side of the Auto Tension.

Insert the nylon thread "A" into the Yarn Feeder ②.

Fasten the thread end to the Clamp.

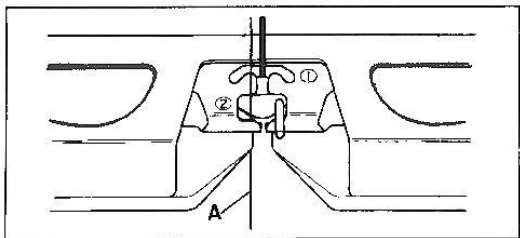

Tension Dial for nylon thread.....7

Push one end needle at both sides of the knitting to D position.

Knit from right to left.
The end needles will not knit.

Knit from left to right.
The end needles will be knitted back to B position.

Knit the required number of rows.

Do not fail to push the two end needles to D position when you move the Carriage from right to left.

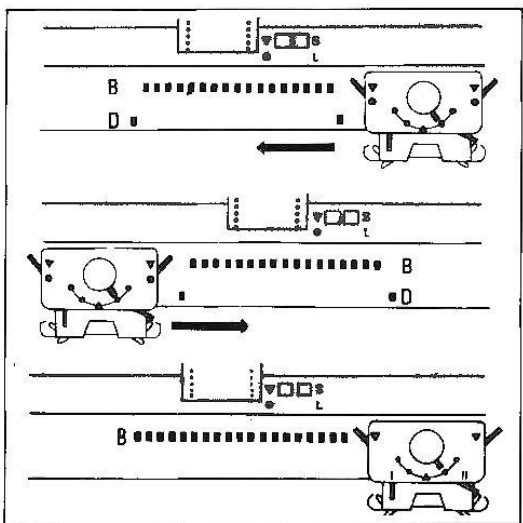

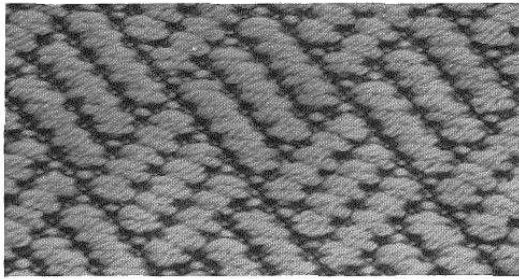

WEAVING

Punch Card No.9-A

Insert the Punch Card.

Set the Controls as required in ORDER 1.

Knit 1 row from left to right.

Hang the Claw Weights at both edges of the knitting.

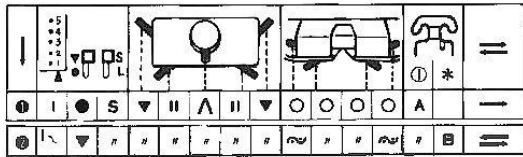

Both Weaving Knobs "A".....

To set the Weaving Knob to , slightly push it forward, it will drop into position.

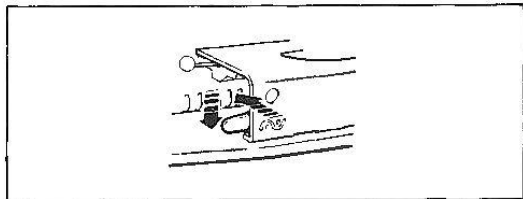

Set the other Controls as required in ORDER 2.

* Weaving Yarn Holder.

Insert second yarn (weaving yarn) into the Auto Tension and pull it down towards the Needle Bed.

Fasten the yarn end to the Clamp.

Set the Tension Dial for weaving yarn as follows:—
medium/thick yarn.....2-3

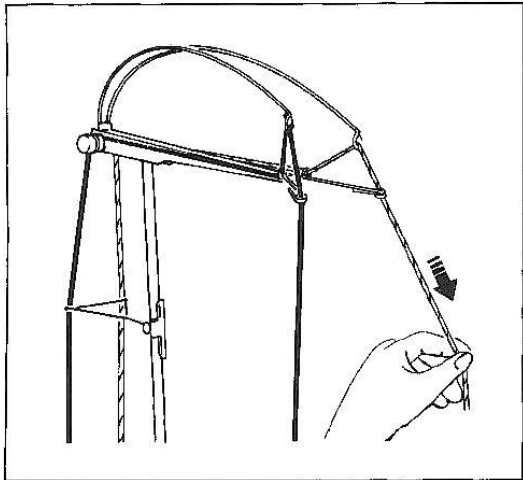

Hook weaving yarn "A" onto the left Weaving Yarn Holder "B". (main yarn is in the Yarn Feeder ①.)

Set the Stitch Dial 1 number higher than that for stockinet.

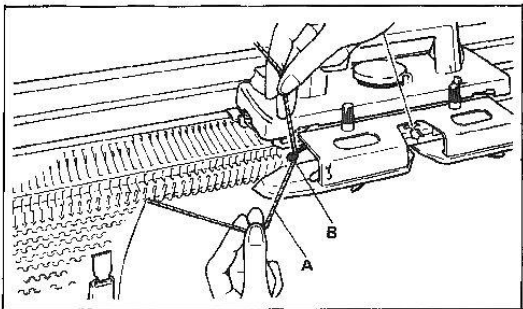

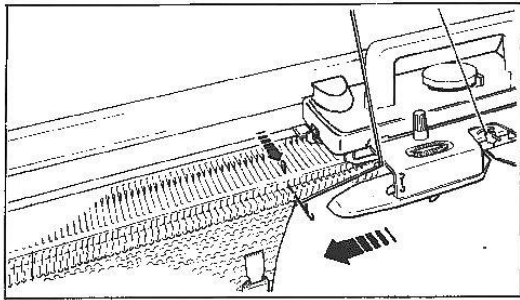

Push one end needle on the Carriage side to D (or C in partial knitting) position.

Knit 1 row.

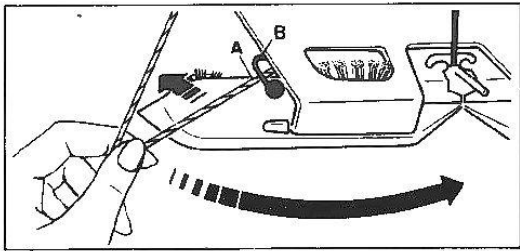

Remove weaving yarn "A" from the left Weaving Yarn Holder "B".

Bring the weaving yarn underneath the Arm and move it to the right side of the Carriage.

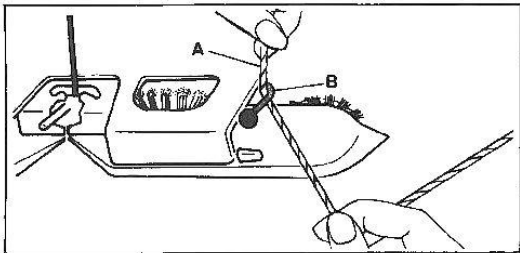

Hook the weaving yarn "A" onto the right Weaving Yarn Holder "B". (main yarn is in the Yarn Feeder ①.)

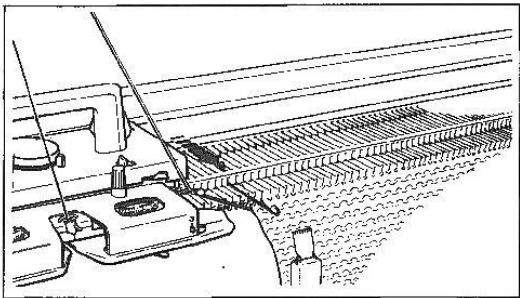

Push one end needle on the Carriage side to D (or C in partial knitting) position before knitting the next row.

Knit from left to right.

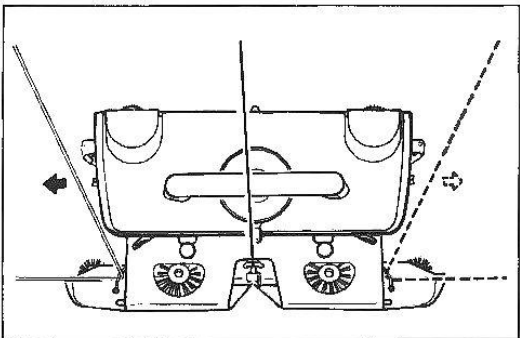

Knit the required number of rows by placing weaving yarn on the leading side of the Carriage alternately.

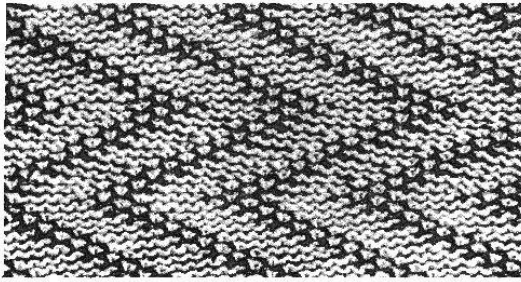

PLATING

Punch Card No.11-A

Insert the Punch Card.

Set the Controls as required in ORDER 1.

Knit 1 row from left to right.

Move the Carriage to the right until the Yarn Feeder has passed the end sinker post.

Hang the Claw Weights at both edges of the knitting.

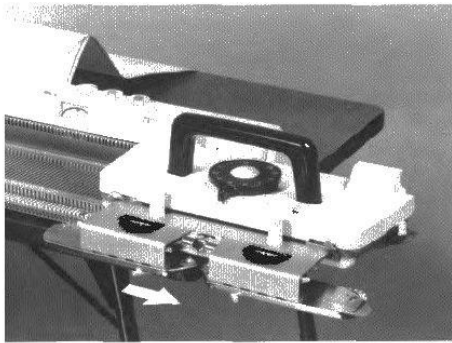
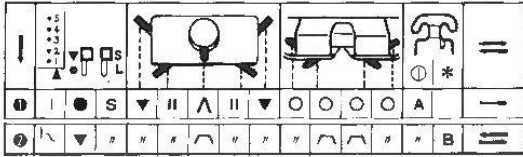

Remove second yarn (plating yarn) from the Yarn Clip and pull it down towards the Carriage.

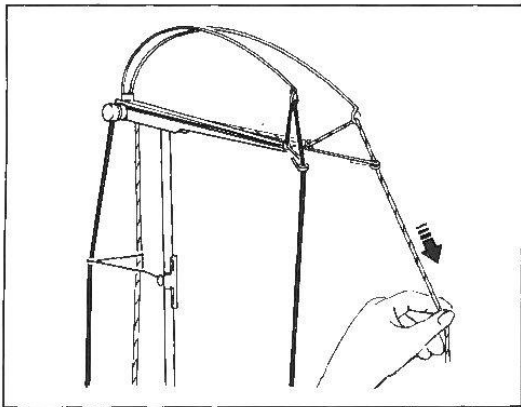

Insert the second yarn into the Yarn Feeder ①.

Main yarn and second yarn are in the Yarn Feeder ①.

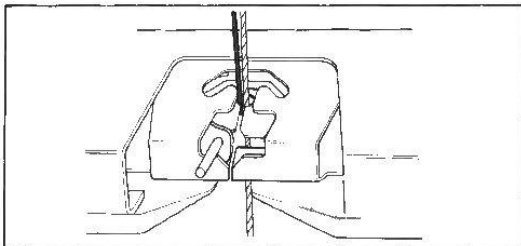

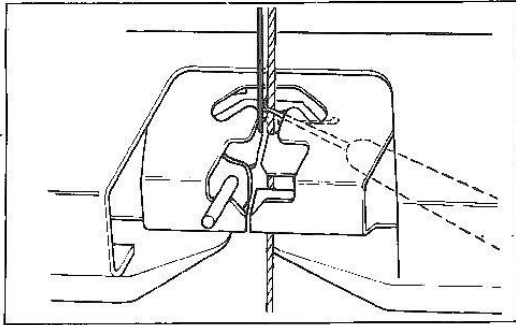

Thread the Plating Yarn Feeder as follows:—

With the right hand, insert the Tappet Tool from underneath the Arm and catch the second yarn (plating yarn) by its hook.

Pull the second yarn away from you and let the yarn end hang underneath the Arm.

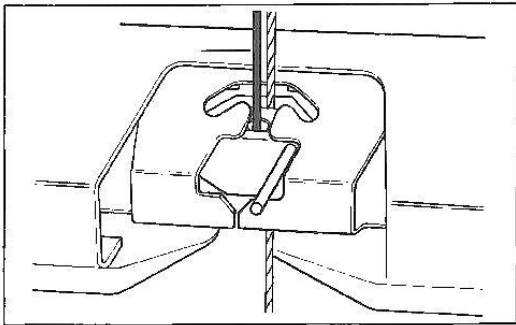

Close the Yarn Feeder Gate.

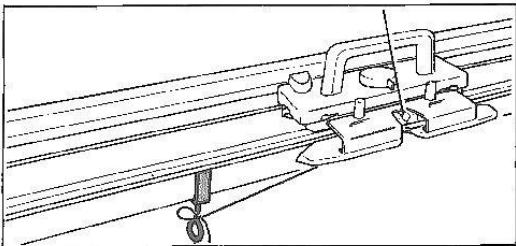

Fasten the yarn end to either Clamp.

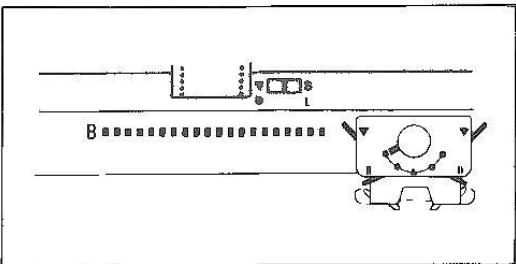

Set the Controls as required in ORDER 2.

* Plating Yarn Feeder.

Knit the required number of rows.

Each yarn appears on the fabric as follows:—

Plating yarnon purl side
Main yarn.....on knit side

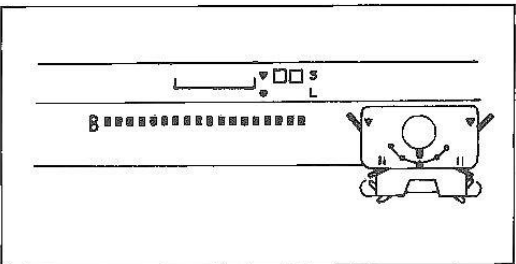

To knit plating in stockinet, set the Controls as required in stockinet knitting.

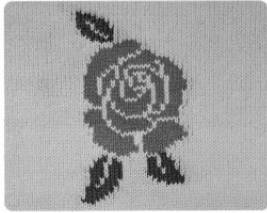

SINGLE MOTIF

Card No.5-A

Insert the Punch Card.

Set the Controls as required in ORDER 1.

Knit 1 row from left to right.

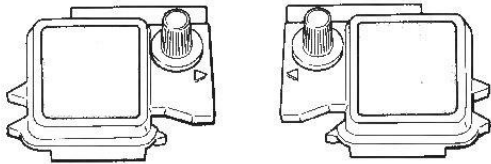
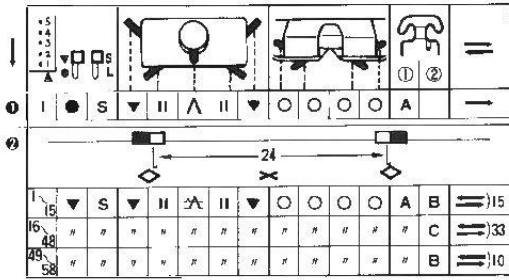

Remove the left and right Magic Cams from the Accessory Box.

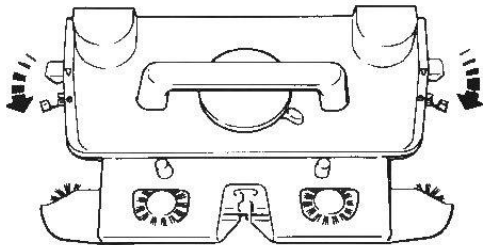

Both Side Levers.....●

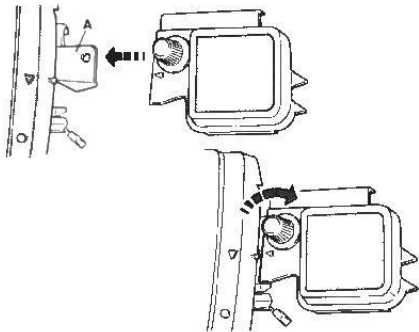

Place both Magic Cams onto the extension plates "A" ensuring that the triangle marks on the Magic Cams correspond with triangle marks on the Carriage.

Fasten the Magic Cams to the extension plates by turning the knurled knobs in the clockwise direction.

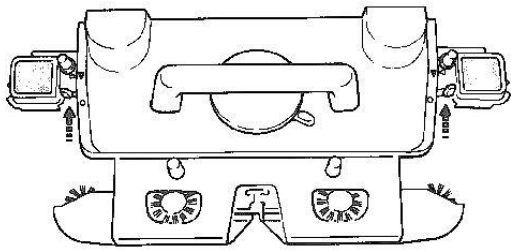

Both Side Levers.....▼

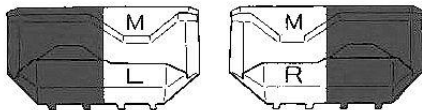

Remove the left and right Point Cams M (orange and white) from the Accessory Box.

left Point Cam – marked M.L.
right Point Cam – marked M.R.

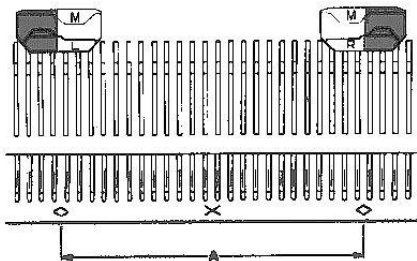

Set both Point Cams M with their division lines (for orange and white) are between 12th and 13th needle on both sides of centre(0) of the Needle Bed.

“D” – needles knitting single motif.

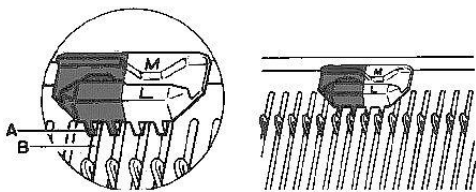

Ensure that the four studs “A” of the Point Cam M fit correctly into the needle groove ends “B”, the farthest from you on the Needle Bed.

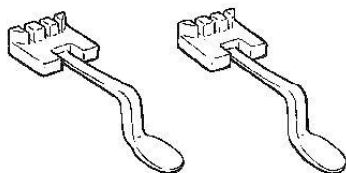

Remove two Yarn Separators from the Accessory Box.

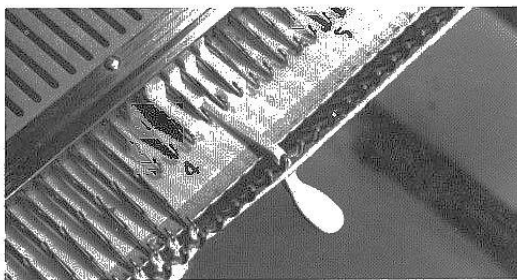

Open latches of the 4th, 5th and 6th non-working needle on the left and right side of the knitting.

Insert the Yarn Separators between these three needles and the Needle Bed as far as they will go.

The yarn must pass over the Yarn Separator.

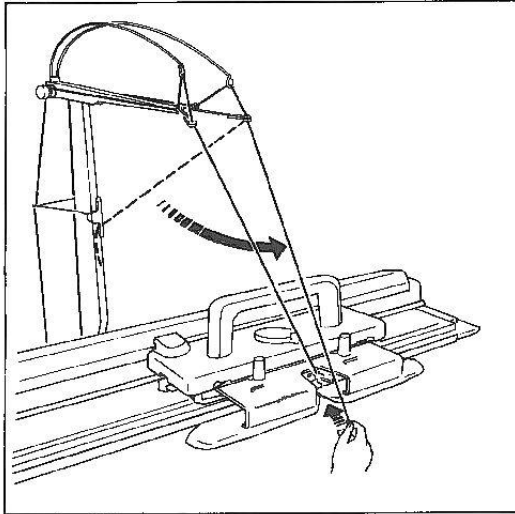

Remove the second yarn end from the Yarn Clip and pull it down towards the Carriage.

Insert the second yarn into the Yarn Feeder ②. Fasten the yarn end to the Clamp.

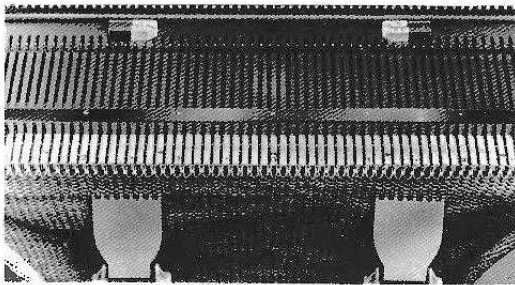
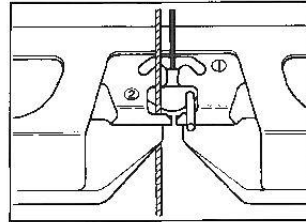

Hang the Claw Weights on the knitting, below the left and right Point Cams M.

Set the Controls as required in ORDER 2.

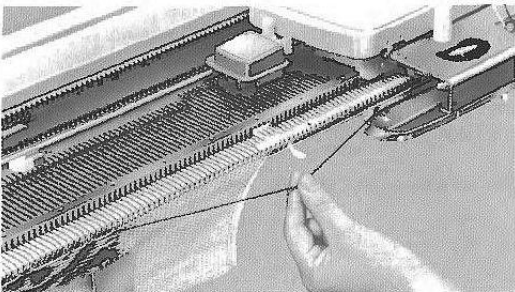
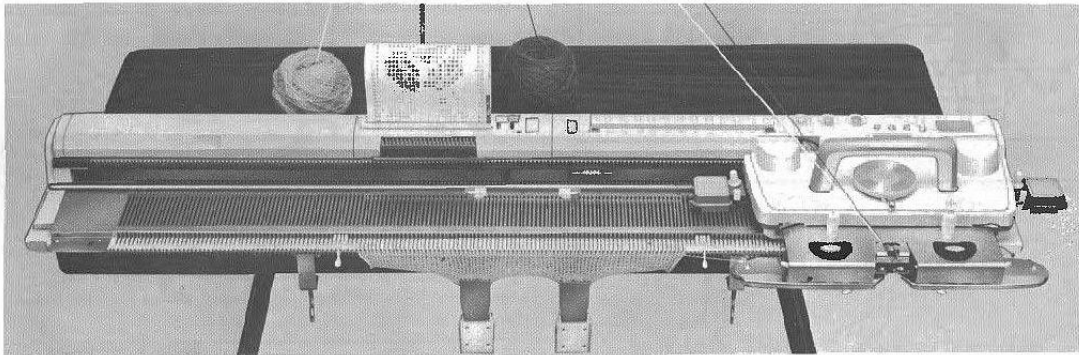

Knit 1 row from right to left.

When knitting single motif, yarns must be arranged as follows:—

- main yarn — over Yarn Separator.
- second yarn — under Yarn Separator.

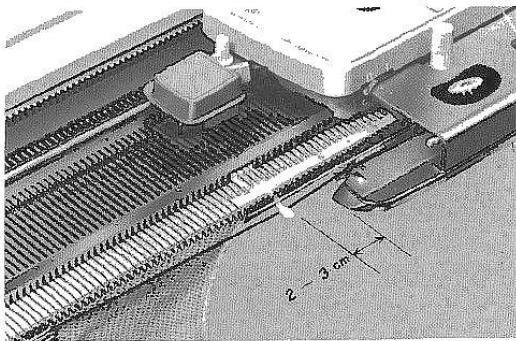

Ensure that the Arm has passed the Yarn Separator by approximately 2-3cm. before knitting the next row.

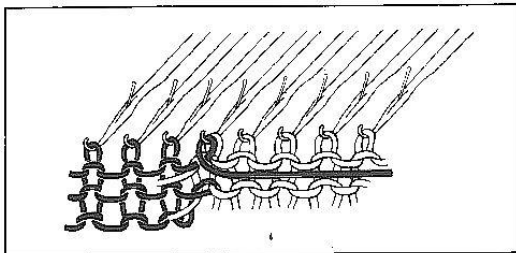

TO OBTAIN A BETTER FINISH IN KNITTING SINGLE MOTIF, WE RECOMMEND THE FOLLOWING.

After each row has been knitted, wind second yarn "A" around hook of the first needle (on the Carriage side) adjacent to the last stitch of motif knitted.

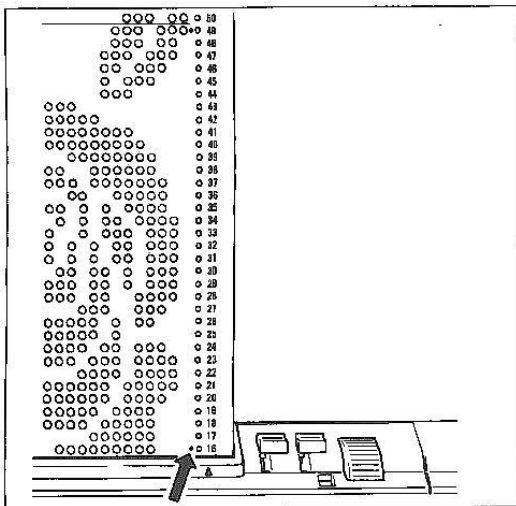

Knit the required number of rows using the two yarns B and C in the Yarn Feeder ② alternately.

TO CHANGE YARNS IN YARN FEEDER ②

Punch Cards No.5, 6-03, 19-03 have red dots alongside Card Memory Numbers indicating the rows to change yarn.

When a red dot reaches above the triangle mark at the Pattern Card Panel, remove second yarn from the Yarn Feeder ②. Insert the third yarn into the Yarn Feeder ② and knit until the next dot reaches using the main yarn and third yarn.

In this instance Card memory numbers 16-49.

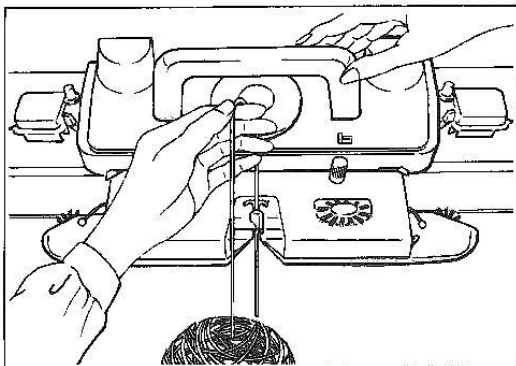

If you knit with more than two yarns, we recommend hand feeding (see page 42) or the purchase of an additional Auto Tension with Yarn Rod.

If single motif is placed far way from centre(0), tension on second yarn is apt to become loose, so it is advisable to place the pattern at the centre portion of knitting, preferably within 150 needles wide.

LEARNING SINGLE MOTIF VARIATIONS

2 sets of left and right Point Cams M (orange and white) are included with your Knitter.

You can enjoy a wide variety of single motif knittings by use of these Point Cams M as guided below.



KNITTING 1 ROSE

To knit 1 rose, place the left and right Point Cams M at two nearest \diamond marks. See page 38.

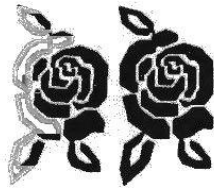
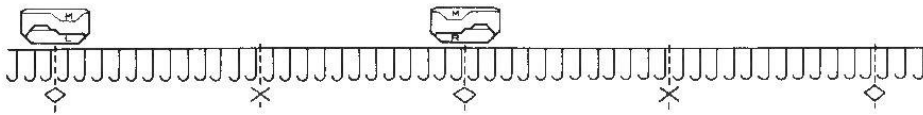

KNITTING 2 ROSES

To knit 2 roses, move the left or right Point Cam M to adjacent \diamond mark.

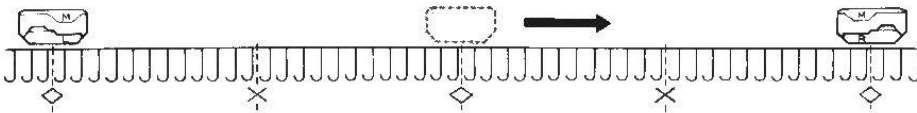

KNITTING 2 ROSES WITH SPACE IN BETWEEN

To knit 2 roses, with a space in between in stockinet, place another set of the left and right Point Cams M at two nearest \diamond marks apart from the first set.

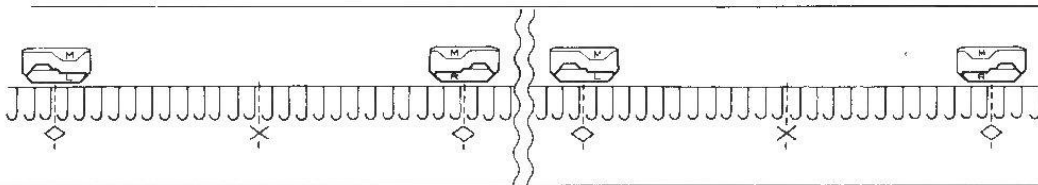

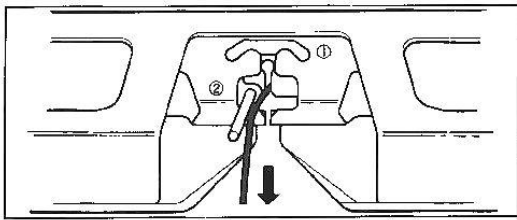

PRACTICING HAND FEEDING

Remove yarn from the Yarn Feeder.

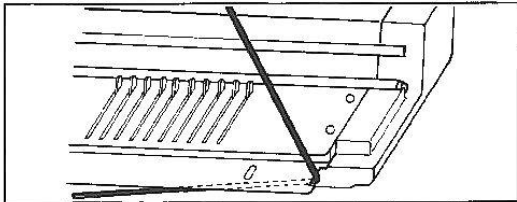

Place the yarn at the cut-out on the side of the Knitter.

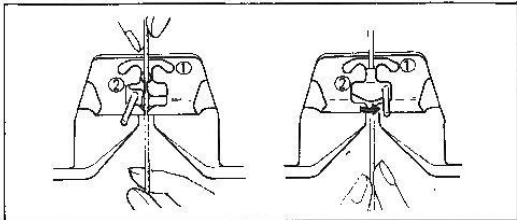

Thread new yarn into the Yarn Feeder with the yarn end hanging approximately 10cm. below the Yarn Feeder.

Close Yarn Feeder Gate.

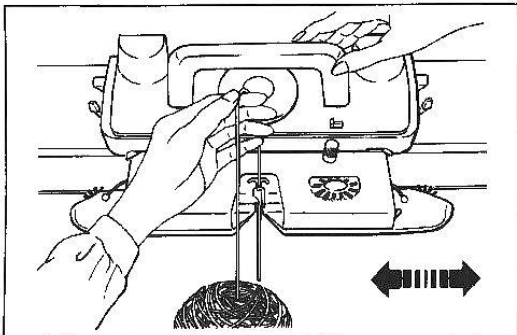

Hold the yarn lightly between the thumb and forefinger.

Knit required number of rows.

Hand feeding is useful for the following occasions:—

1. When knitting using the third yarn for a small area.
2. When knitting knitted-in hem using the Ravel Cord for separating main knitting from waste knitting.

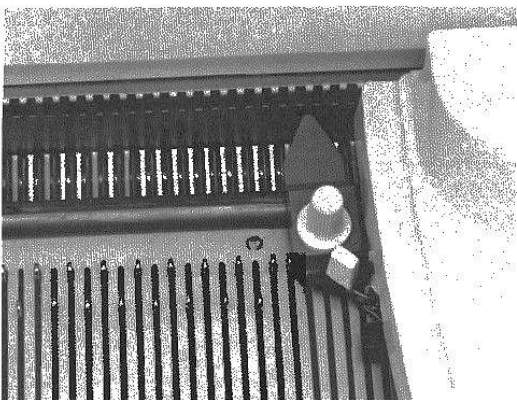

AUXILIARY FEEDING CAM

This attachment is used when you knit a garment on the Knit Contour.

See page 8 on Knitting Manual.

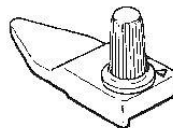

LACE CARRIAGE

or setting up the Knitter and preparation of yarn before knitting,
read the instructions on pages 1-10.

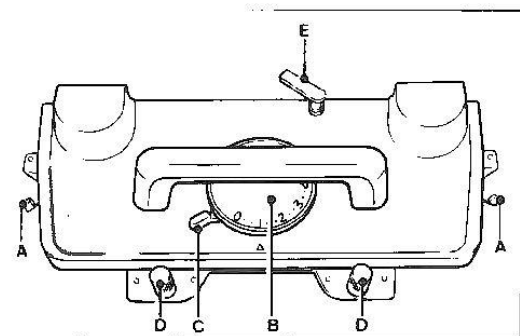
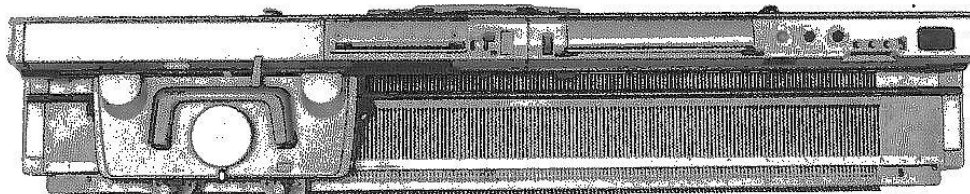

CARRIAGE

- A - Side Levers
- B - Stitch Dial
- C - Cam Lever
- D - Arm Nuts
- E - Row Counter Tripper

ADDITIONAL ACCESSORIES

- F - Comb Weight (3) 02470367
- G - Claw Weight (3) 07422009
- H - Ribber Join Screw (2) 01933712
- I - Edge Pin (6) 62270361
- J - Punch Card (10) 02460368

To order, specify part name with part number)

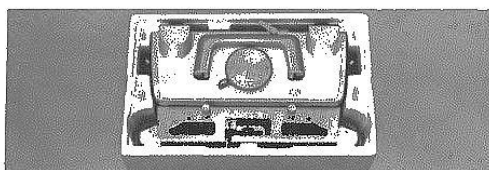
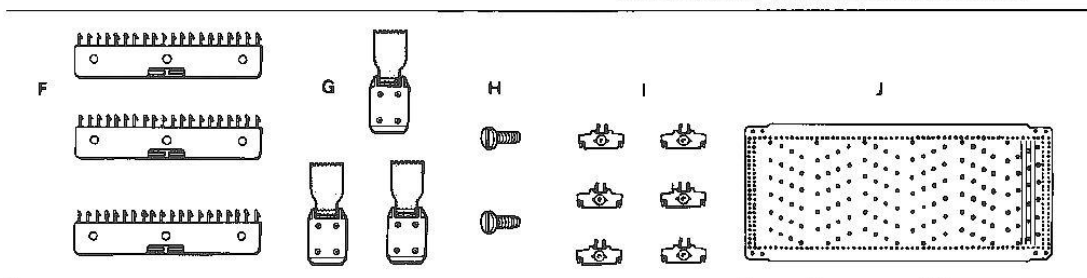

Lace Carriage and Arm for 360/260KL has been packed
separately in styrofoam packing.

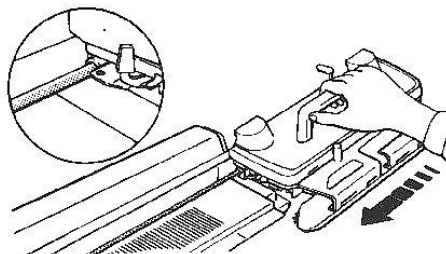

Remove the Lace Carriage with Arm from the packing
and raise the Carriage Handle.

Mount the Lace Carriage to the Needle Bed from the
right side.

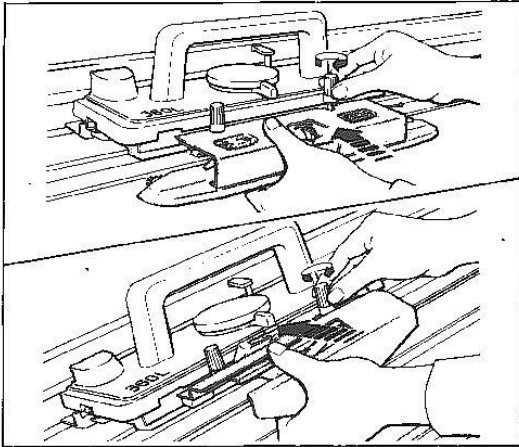

NOTE FOR USING THE LACE CARRIAGE

Do not attach the Main Carriage Arm to the Lace Carriage.

Do not connect the Ribber Arm to 360/260L Carriage. The Ribber Arm can only be connected to 360/260K Carriage.

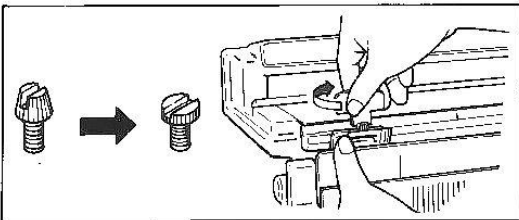

If you knit with the SRP-50 Ribber connected in the lower position, ensure the following:—

1. Replace the Ribber Join Screws "A" with the included Screws "B".

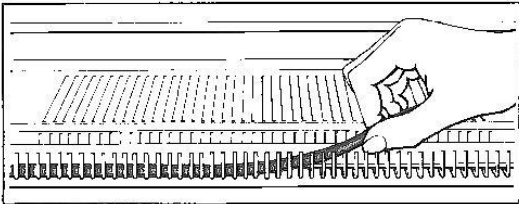

2. Remove the Close Knit Bar from the Needle Bed, if it is in use.

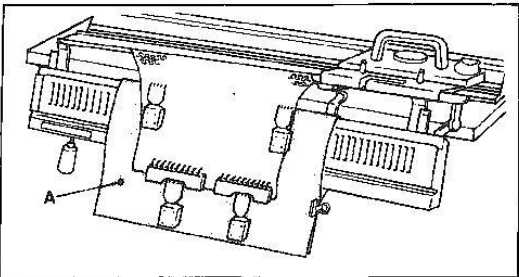

3. With hard paper or heavy cloth "A", cover the Ribber needles and sinker posts to bring the knitting in front of the Ribber.

(Optional Plastic Ribber Needle Bed Cover is available.)

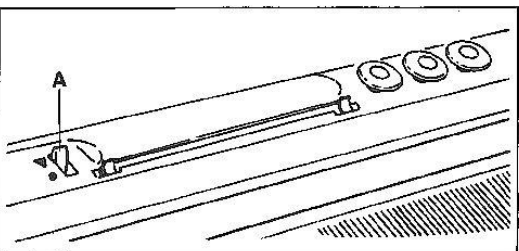

If the L Carriage is used on the Model 360 Knitter, be sure to set the Paper Lever "A" of the Knit Contour to ▼ mark, otherwise it will interfere with the Row Counter Tripper.

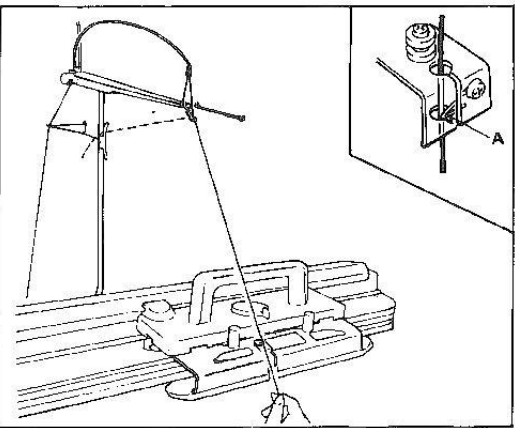
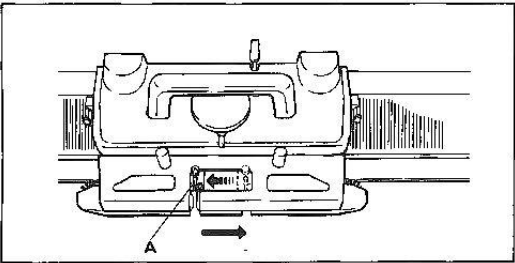
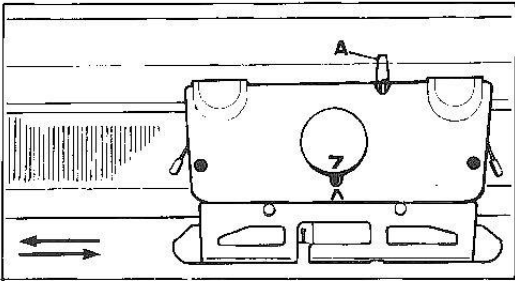
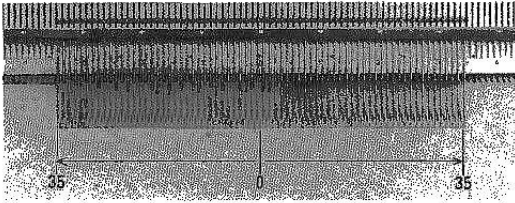
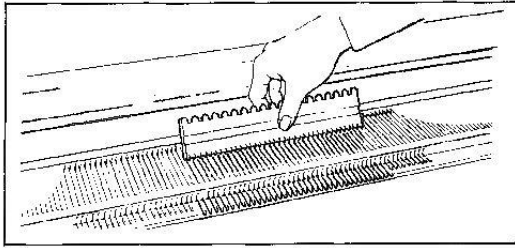

TO CAST ON

Push 35 needles on the left and right side of centre (0), 70 needles in total, from A position to B using the straight edge of the Needle Pusher.

SETTING CARRIAGE

Stitch Dial.....7
 Cam Lever.....A
 Side Levers (left and right).....●

The Cam Lever is synchronized with the Row Counter Tripper "A".

Cam Lever position

- A.....Row Counter is operated.
- ⌘.....Row Counter is not operated.

Do not adjust the Row Counter Tripper by hand.

Slowly move the Carriage across the Needle Bed until it has passed all the needles.

Place the Carriage at the right side.

Move the Carriage to the right to let Yarn Feeder "A" locate at the left side in the Arm.

For threading or unthreading the Yarn Feeder, it must be at the left side.

Remove the yarn end from Yarn Clip and bring it down to the Carriage.

Hold the yarn with both hands and slide it into the yarn feeder.

The yarn must be pushed behind guide pin "A".

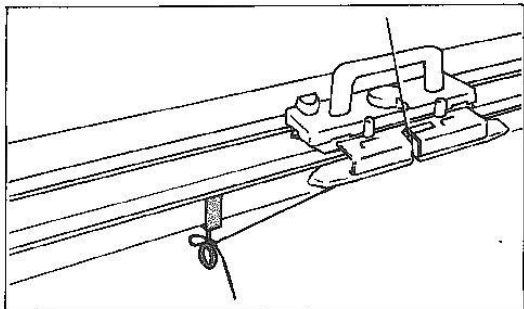

Fasten the yarn end to either Clamp.

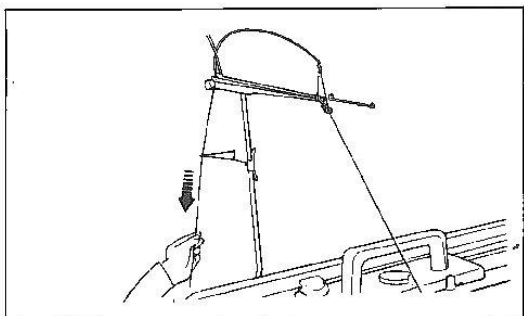

Eliminate slack yarn by pulling the yarn down at the back of Yarn Rod until the Tension Spring is nearly in the horizontal position.

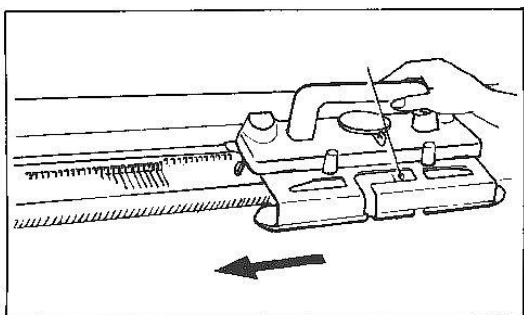

Move the Carriage from right to left, knitting 1 row.

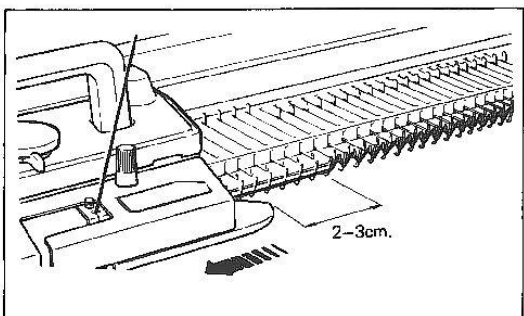

Ensure that the Arm has passed the last knitting needle by approximately 2-3cm.

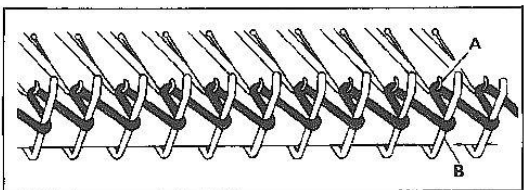

Even loops have been formed between needle hooks "A" and sinker posts "B".

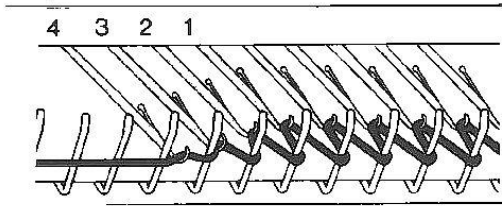

When knitting the first row, it might happen that the loops get smaller towards the left side on the needle hooks "1", "2", "3" and "4".

To have successful cast on, these smaller loops must be corrected.

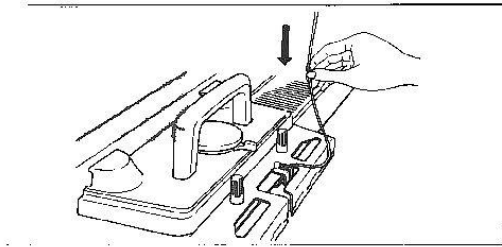

To correct, hold yarn above the Yarn Feeder and pull it down to allow some slack.

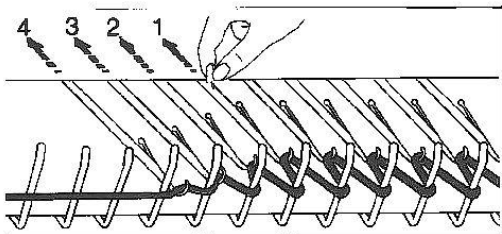

Starting from the smallest loop furthest away from the Carriage, in this case the loop on the needle "1", push the needles with small loops one by one back to B position.

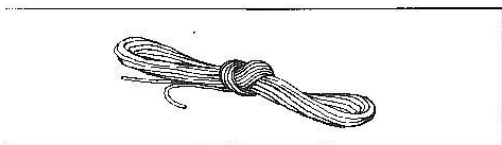

Remove Ravel Cord from the Accessory Box. Untwist it and check that there are no knots in the Cord before using, otherwise you can not pull it out of the knitting after cast on.

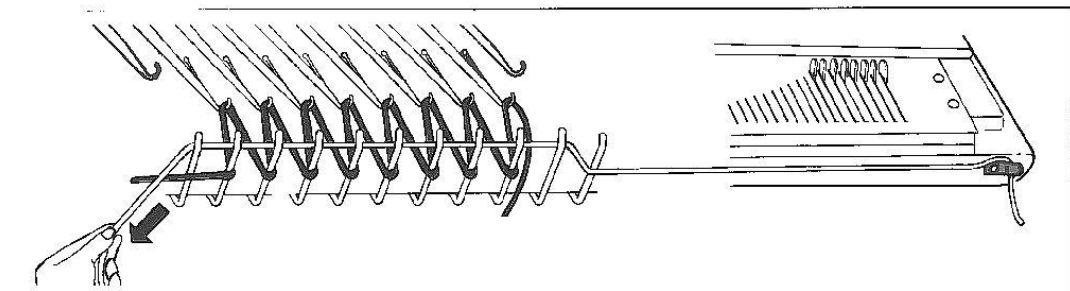

Hook the end of the Ravel Cord "A" in the Yarn Holder "B" at the right side of the Needle Bed.

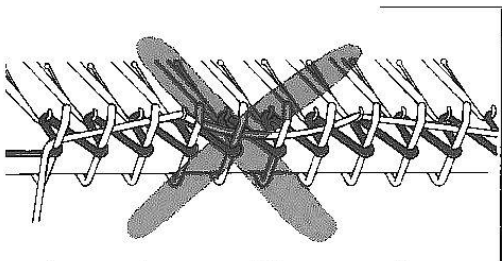

Lay the Ravel Cord across the yarn loops between needle hooks "C" and sinker posts "D". Strain the Ravel Cord with the left hand.

Ensure that the Ravel Cord lies correctly across the loops and will not entangle with needle hooks.

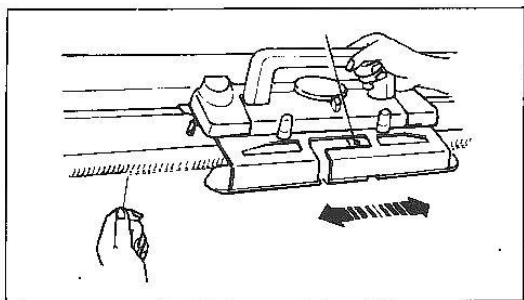

Move the Carriage from left to right.

Continue to knit 5–6 rows.

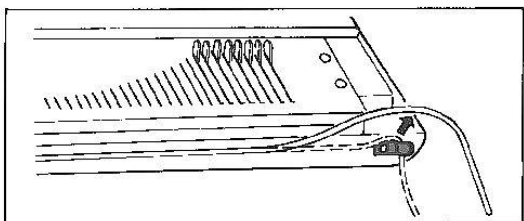

Remove the end of the Ravel Cord from the Yarn Holder at the side of the Needle Bed.

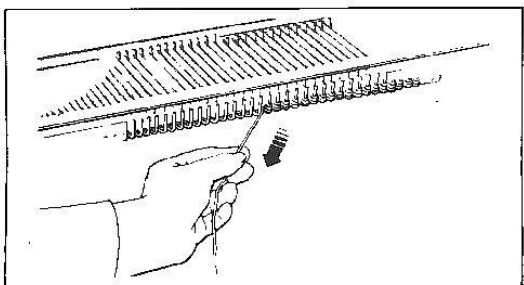

Remove the Ravel Cord by pulling it to the left.

You have finished cast on.

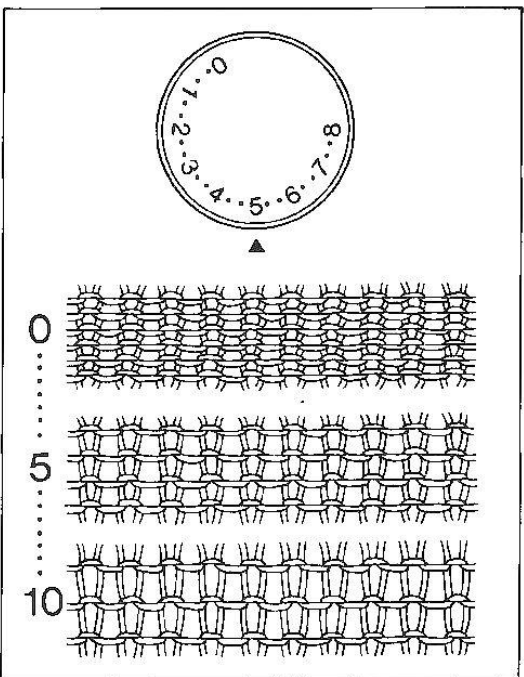

LEARNING ABOUT STITCH SIZE AND YARN

STITCH DIAL

Ensure that the correct Stitch Dial number is always selected for the yarn you will select.

Stitch Dial regulates the size of a stitch.

When the Stitch Dial is set to 0, the tightest stitch size is obtained. (smallest stitch)

When the Stitch Dial is set to 10, the loosest stitch size is obtained. (largest stitch)

To select a number, turn the Stitch Dial until the required number or dot corresponds to ▲.

If the tension is too tight – it will be difficult or even impossible to knit, you will use more yarn and waste money – your garment will be hard and uncomfortable to wear.

If the tension is too loose – your garment will have no shape or will very soon lose its shape.

For practice, continue to knit with different Stitch Dial numbers as follows:–

1. with the Stitch Dial number 3, knit 10 rows – tightest stitch size is obtained.
2. with the Stitch Dial number 9, knit 10 rows – loosest stitch size is obtained.

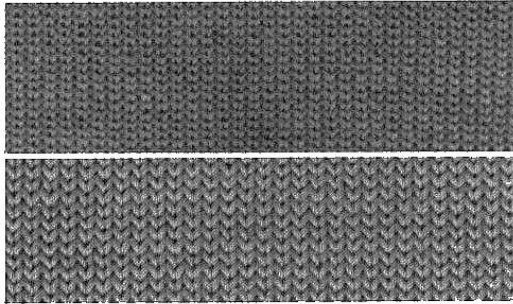

STITCH SIZE AND STITCH DIAL NUMBER FOR A YARN

- ② – Stitch Dial at 1 with yarn ② (2-ply)
- ⑤ – Stitch Dial at 5 with yarn ⑤ (4-ply)

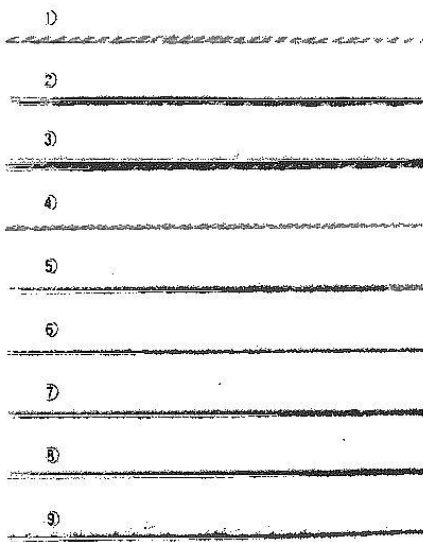

Type of yarn	Stitch Dial (stockinet)	Stitch Dial (lace knitting)
① Thin yarn (2-ply)	2-3	(3)-4
② Light yarn (3-ply)	3-5	4-5
③ Medium yarn (4-ply)	4-6	5-6
④ Cotton thread (thin)	3-4	4-5
⑤ Cotton thread (regular)	4-5	5-6
⑥ Synthetic (thin)	2-3	(3)-4
⑦ Synthetic (regular)	3-4	4-5
⑧ Synthetic (regular)	3-4	4-5
⑨ Mohair (thin)	3-5	4-5

NOTE FOR LACE KNITTING
 USE HIGHER STITCH DIAL NUMBER THAN that for STOCKINET.
 DO NOT USE KNOBLY YARN OR THICK MOHAIR YARN.

KNITTING STOCKINET

Remove the yarn end from the Clamp.

- Stitch Dial.....5
- Cam Lever.....Λ
- Both Side Levers.....●

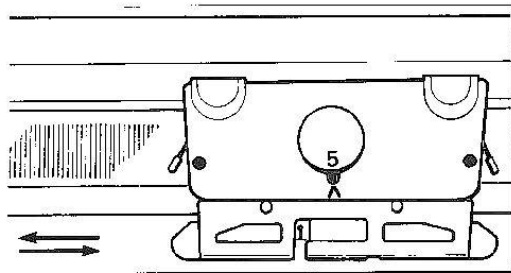

For practice, knit 30 rows.

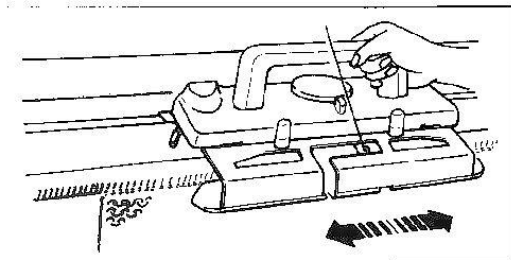

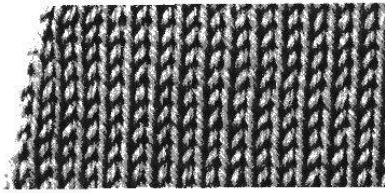

DECREASING 1 STITCH

You can decrease 1 stitch on both sides of the row.

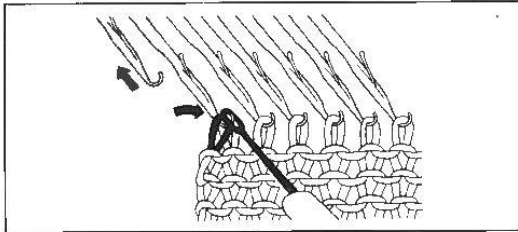

Using the Transfer Tool, transfer the end stitch onto its adjacent needle.

Push back the empty needle to A position.

For practice, knit more rows decreasing 1 stitch on both sides of the row.

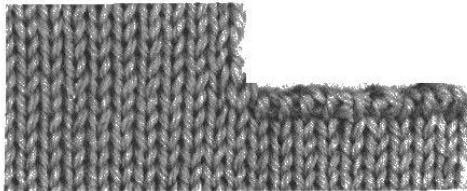

DECREASING MULTIPLE STITCHES

You can only decrease on the Carriage side.

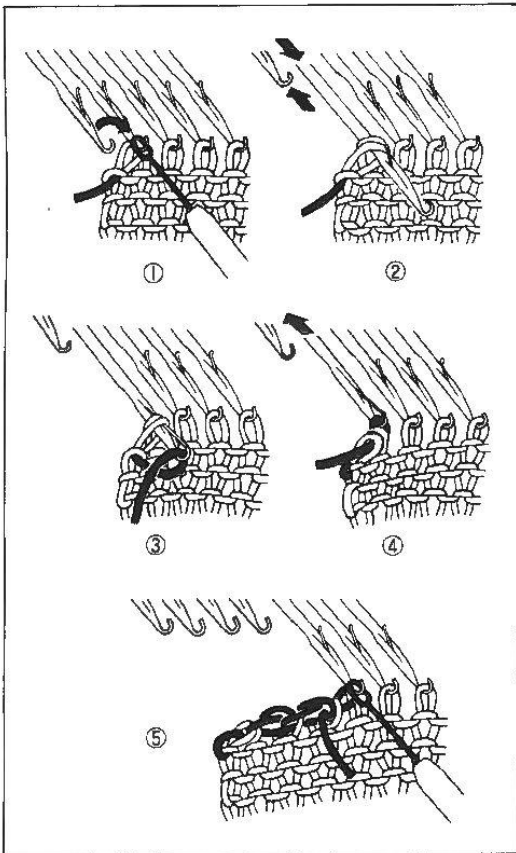

① On the Carriage side, hold the fabric towards the Knitter.
Transfer the end stitch to the adjacent needle.

② Push the empty needle to A position.
Push the second needle to D position until both stitches are behind the latch.

③ Lay yarn from right to left on the open hook of the needle.

④ Hold yarn slightly down and push the needle back to B position.
The two stitches slip off the needle.

⑤ Continue this procedure until the required number of stitches have been decreased.
Place the last decreased stitch onto its adjacent needle.

For practice, decrease four stitches on both sides.

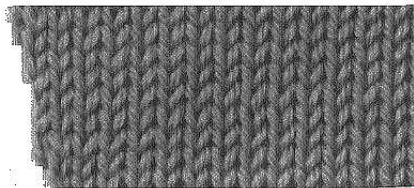

INCREASING 1 STITCH

You can increase 1 stitch at a time on the Carriage side.

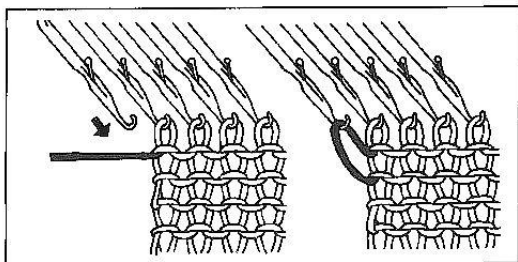

Push 1 needle on the Carriage side from A to B position.

For practice, knit more rows increasing 1 stitch on the Carriage side on the row.

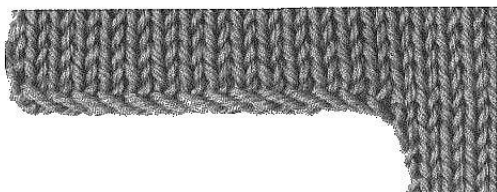

INCREASING MULTIPLE STITCHES

You can only increase on the Carriage side.

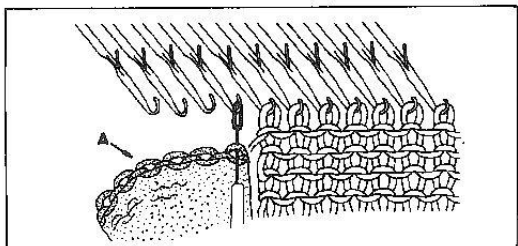

Push up the required number of needles for increase from A position to B.

Prepare a knitted piece "A", and using the Transfer Tool pick up stitches from it and hook them on the needles.

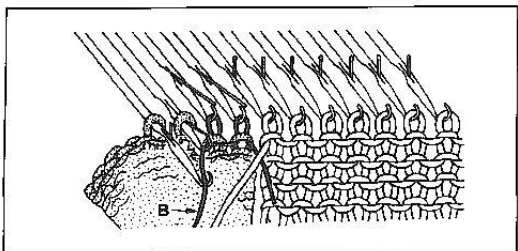

Push up the needles from B position to D and lay the Ravel Cord "B" on needle hooks.

(Stitches of the knitted piece are behind needle latches.)

Push the needles one by one and form loops.

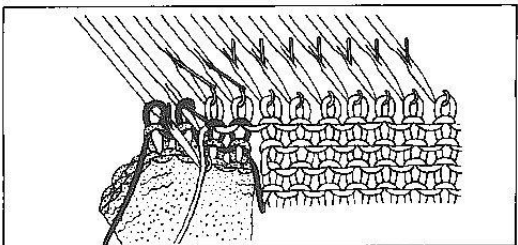

Push up the needles from B position to D and lay main yarn on the needle hooks.

Push the needles one by one and form loops in the same manner as done for the Ravel Cord.

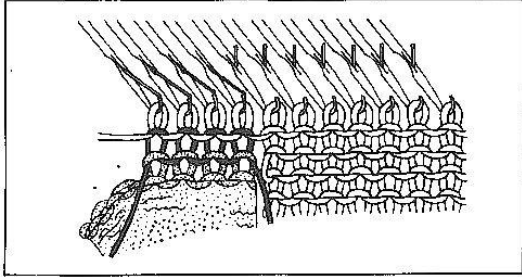

Knit the required number of rows.

For practice, increase four stitches on both sides.

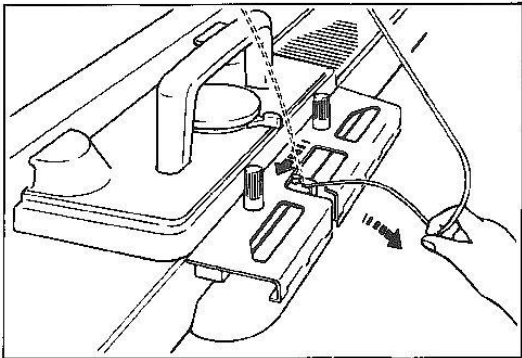

REMOVING KNITTED FABRIC

– without closing end stitches

Place the Yarn Feeder at the left side and remove the yarn.
To remove yarn from the Yarn Feeder, pull yarn towards you.
The yarn will then be released from guide pin "A".

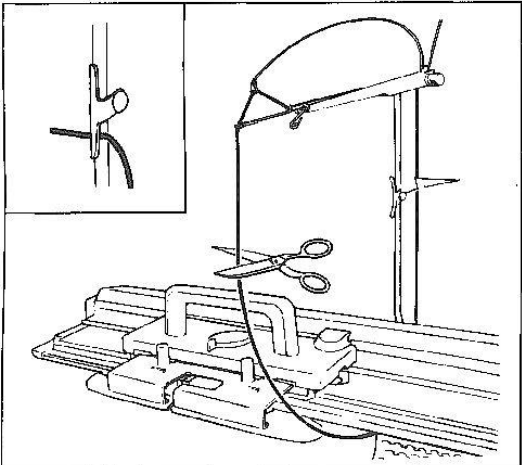

Break the yarn and hook its top end onto the Yarn Clip.

Let bottom yarn end hang loosely on the side of the fabric.

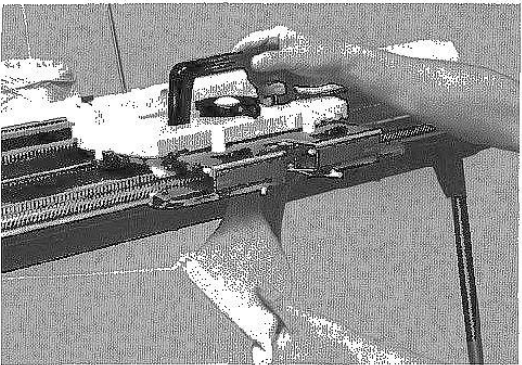

Cam Lever.....▲
Move the Carriage across the knitting.
The fabric will come off the needles.

PRACTICING HAND FEEDING
If you wish to practice hand feeding on your Lace Carriage, see page 42.

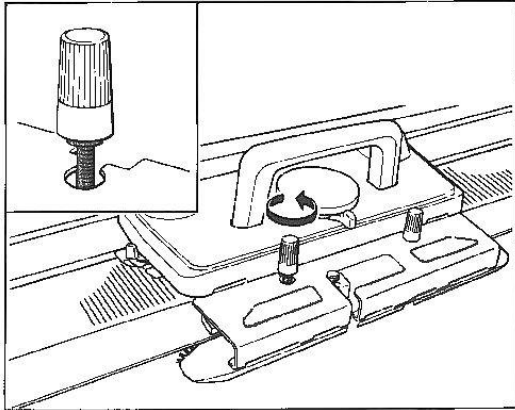

IMPORTANT

IF YOU HAVE ANY DIFFICULTY IN KNITTING THE FIRST ROW, ENSURE THAT:

Arm is attached to the Carriage correctly.

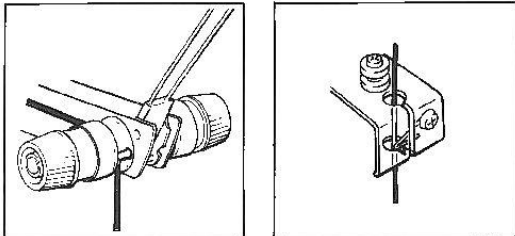

Yarn is threaded correctly through the Auto Tension and Yarn Feeder.

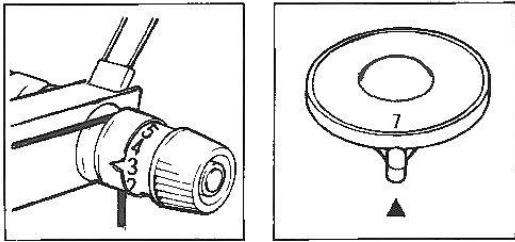

Tension Dial and Cam Lever are set correctly.

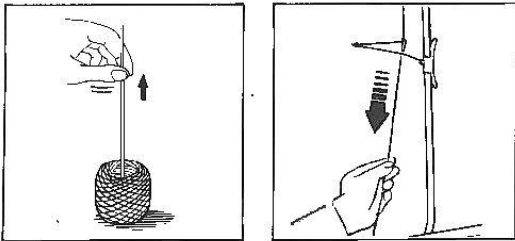

Yarn is wound correctly.

Slack yarn is eliminated and Tension Spring is nearly in a horizontal position.

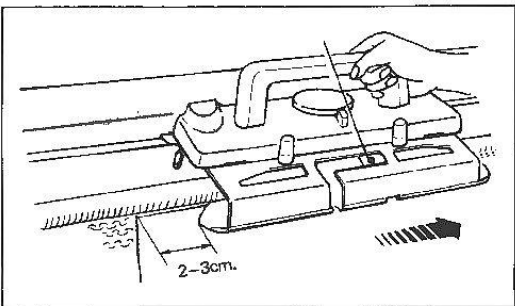

Arm "A" has passed the last knitting needles by approximately 2-3cm. before knitting the next row.

PATTERN KNITTING WITH LACE CARRIAGE

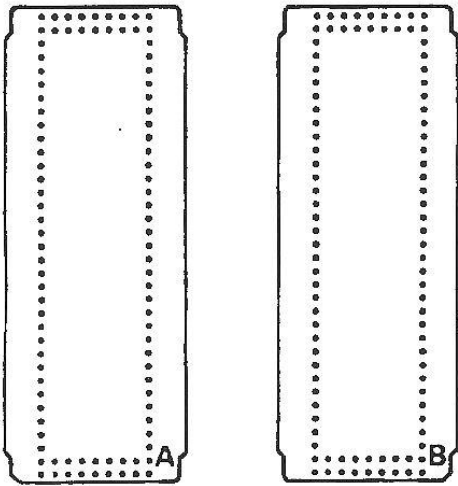

STANDARD PUNCH CARDS FOR LACE CARRIAGE

10 Punch Cards are numbered L-1 ~ L-10.

Punch Card No. L-1 ~ L-8 (for plain lace)

Each Punch Card can be used in two ways and is marked "A" and "B".

If "A" or "B" side of Punch Card is inserted into the Pattern Card Panel, direction of pattern can be changed.

Punch Card No. L-9 ~ L-10 (for fashion lace)

Only one side of Punch Card can be used.

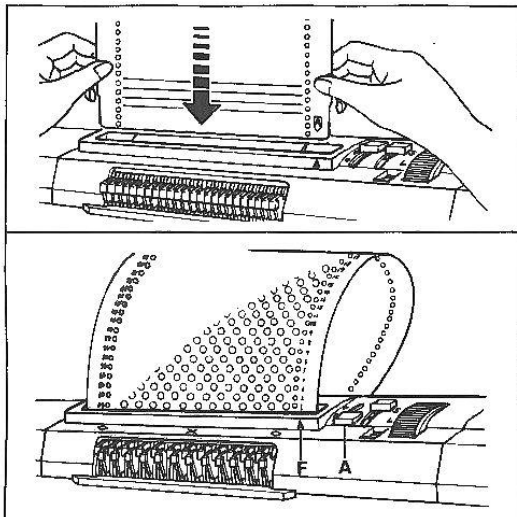

IMPORTANT: Do not fold or bend the Card.

INSERTING PUNCH CARD

For instruction, see pages 22-23.

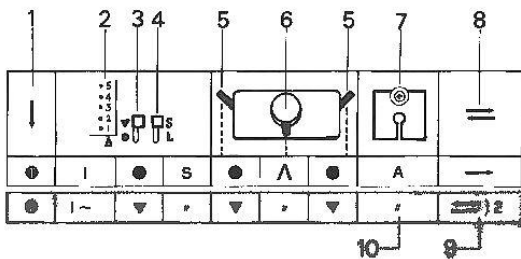

READING OPERATION TABLE

- 1 - Order
- 2 - Card Memory Number
- 3 - Stop Knob
- 4 - L Knob
- 5 - Side Levers
- 6 - Cam Lever
- 7 - Yarn Feeder
- 8 - knitting direction
- 9 - the required number of rows should be knitted
- 10 - A stands for knitting yarn



Point Cams M setting

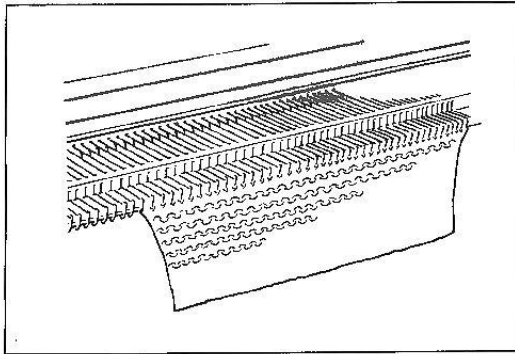

CAUTION ON LACE KNITTING

Before practicing lace knitting, knit about 30 rows in stockinet.

When you use A side of the Punch Card, place the Carriage at the left side of the Needle Bed.

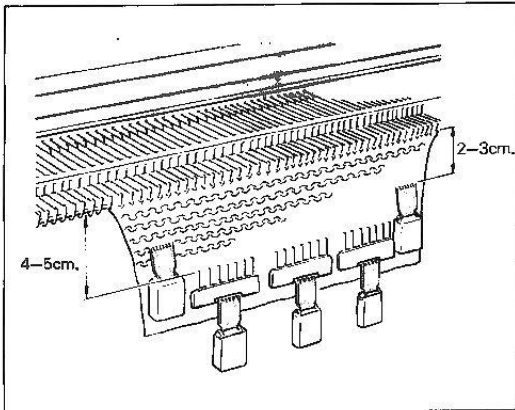

Hook the Comb Weights on the knitting approximately 4-5cm. away from the Needle Bed.
Place the Claw Weights on the Comb Weights.

Hook the Claw Weights on both edges of the knitting approximately 2-3cm. away from the Needle Bed.

Move the Weights up after you have knitted about 50 rows.

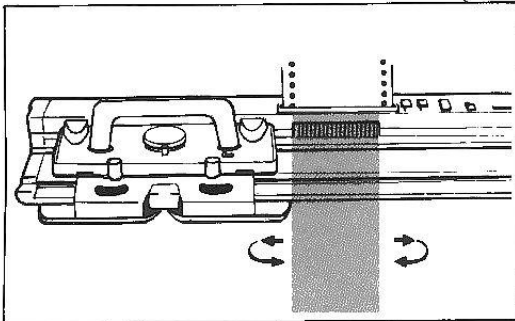

While lace knitting, do not set the L Knob to L.

When moving the Carriage back and forth, ensure that the Carriage has passed the 24 needles corresponding to the Touch Levers "A".
Move the Carriage at an even speed.

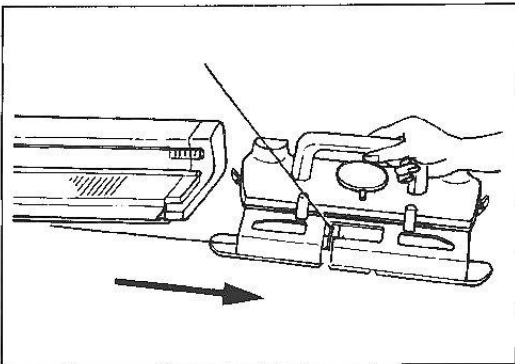

Do not remove the Carriage from the Needle Bed.

If the Carriage has been removed from the Needle Bed by accident, see page 64 for adjustment.

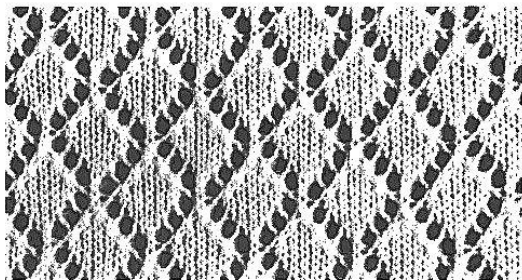

PLAIN LACE

Punch Card No.L-1 - A

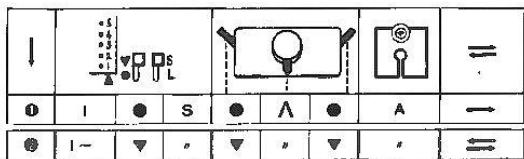

Insert the Punch Card.

Set the Controls as required in ORDER 1.

Knit 1 row from left to right.

Hang the Comb Weights and Claw Weights.

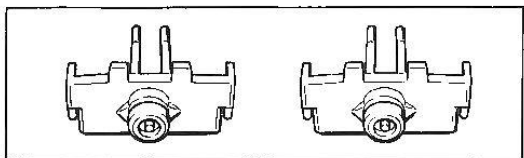

Remove two Edge Pins (orange) from the Accessory Box.

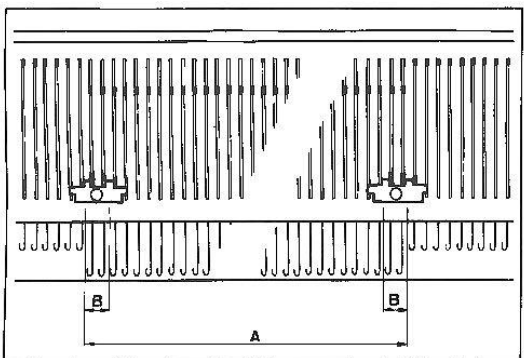

Set the Edge Pins with their knobs between last two working needles on both sides of the knitting:

- A - needles knitting lace in B position
- B - 2 needles knitting stockinet

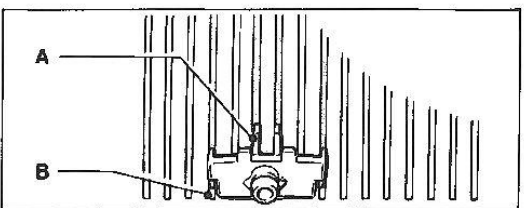

Ensure that the four studs "A" of the Edge Pin fit correctly into the needle groove ends "B", the nearest to you on the Needle Bed.

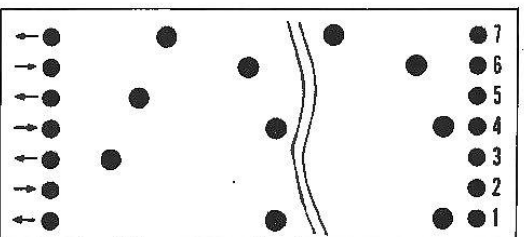

Set the Controls as required in ORDER 2.

Knit the required number of rows.

Move the Carriage to the directions as guided by arrow marks on the left side of the Punch Card.

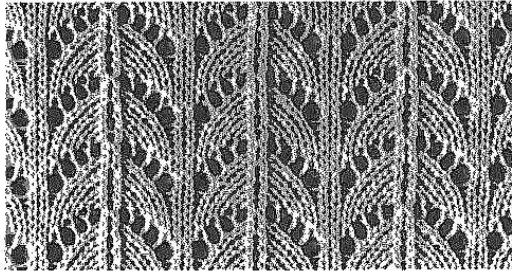

FASHION LACE

Punch Card No.L-10

Insert the Punch Card.

Set the Controls as required in ORDER 1.









Knit 1 row from left to right.

Hang the Comb Weights and the Claw Weights.

Set the Controls as required in ORDER 2.

Knit 2 rows and place the Carriage at the right side.

Cam Lever..... 

									
①	I	●	S	●	△	●	A	—	—
②	1-2	▽	"	▽	"	▽	"	≡	2
③	3-10	"	"	"	∩	"	"	≡	8
④	11-12	"	"	"	△	"	A	≡	2
⑤	13-18	"	"	"	∩	"	"	≡	6
⑥	19-20	"	"	"	△	"	A	≡	2
⑦	21-24	"	"	"	∩	"	"	≡	4
⑧	25-26	"	"	"	△	"	A	≡	2
⑨	27-28	"	"	"	∩	"	"	≡	2

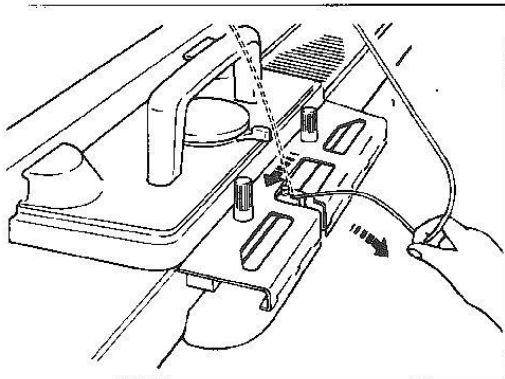

Remove yarn from the Yarn Feeder.

To remove yarn from the Yarn Feeder, pull yarn towards you. The yarn will then be released from Guide Pin "A".

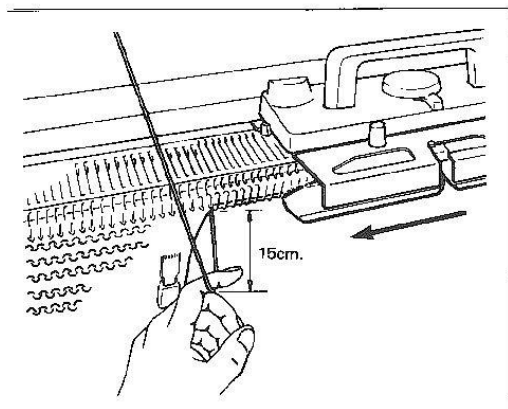

With the left forefinger, pull the yarn down approximately 15cm. from the Needle Bed and slightly towards you, giving a sufficient space so that the Carriage is not entangled with the yarn while moving on the Needle Bed without yarn in the Yarn Feeder.

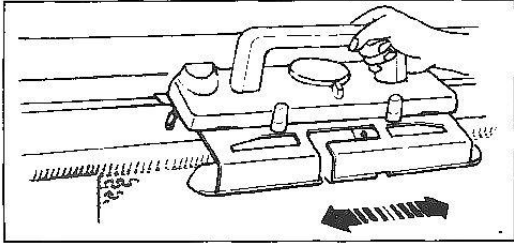

Move the Carriage 8 times over the marked Card Memory Numbers 3–10, and place the Carriage at the right side of the Needle Bed.

During the Carriage movement, the Carriage does not knit but transfer the required stitches to adjacent needles.

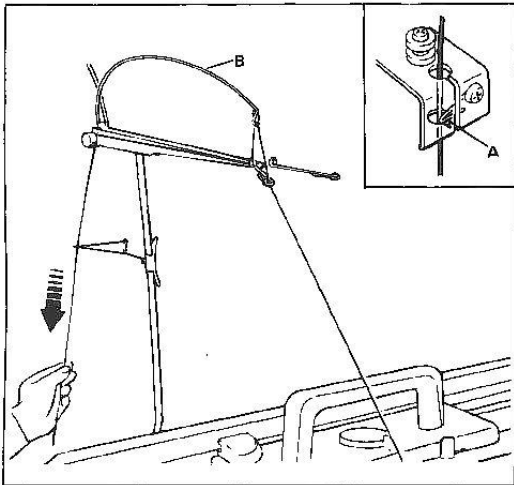
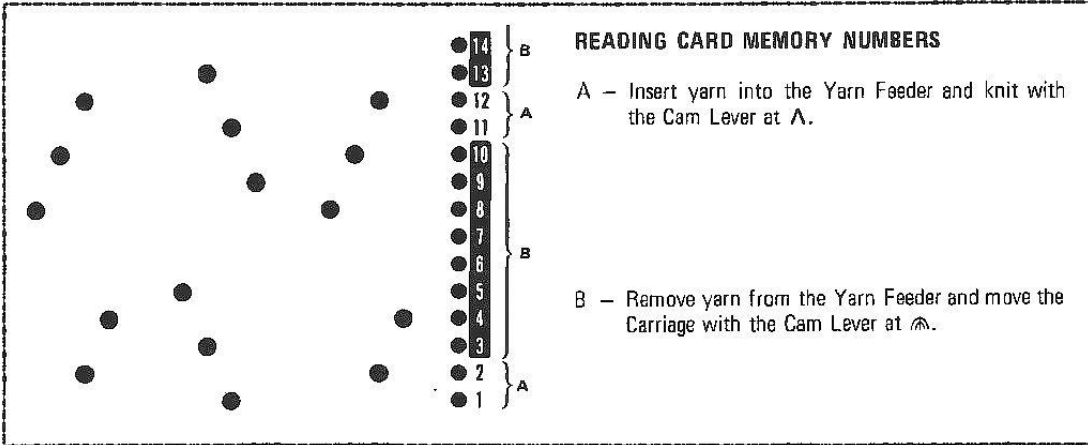

Insert yarn back into the Yarn Feeder.

Yarn must be inserted behind the Guide Pin "A".

Eliminate slack yarn by pulling the yarn down at the back of the Yarn Rod until tension spring "B" is nearly in the horizontal position.

Set the Cam Lever to A as required in ORDER 3.

Knit 2 rows over the Card Memory Numbers 11–12.

From the Card Memory Number 13 onwards, knit the required number of rows following the instructions for READING CARD MEMORY NUMBERS.

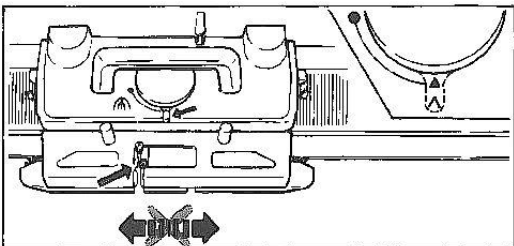

DO NOT MOVE THE CARRIAGE WHEN YARN IS NOT IN THE YARN FEEDER AND CAM LEVER IS SET TO A, OTHERWISE THE FABRIC WILL DROP FROM THE MACHINE.

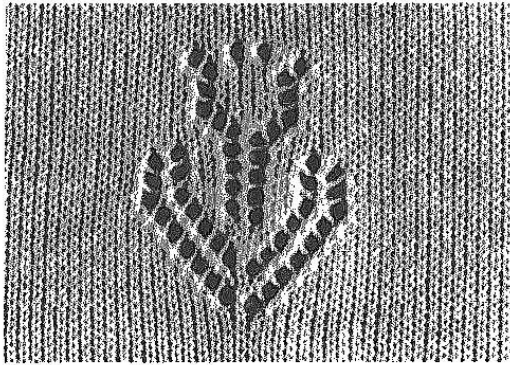

SINGLE MOTIF LACE

Punch Card No. L-8 - A

Insert the Punch Card.

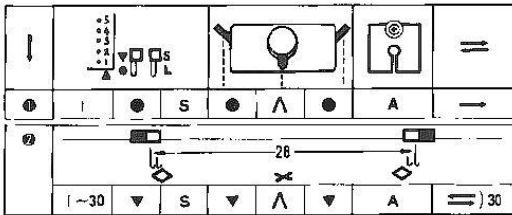

Set the Controls as required in ORDER 1.

Knit 1 row from left to right.

Hang the Comb Weights and Claw Weights.

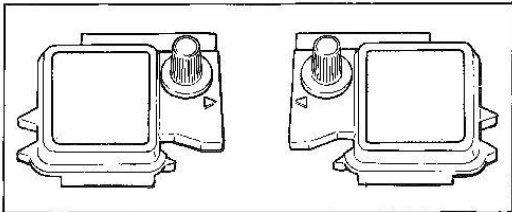

Remove the left and right Magic Cams from the Accessory Box.

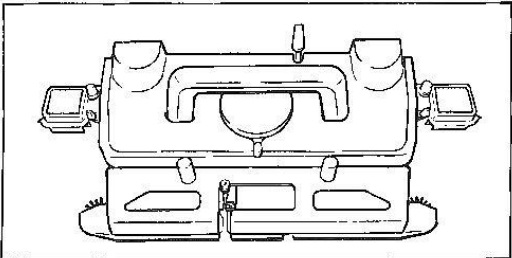

Attach the Magic Cams to the Carriage.
For instruction, see pages 37-38.

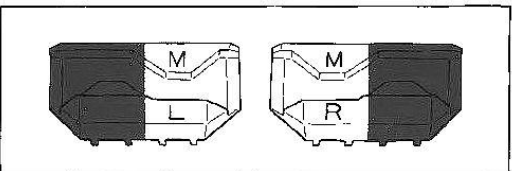

Remove the left and right Point Cams M (orange and white) from the Accessory Box.

left Point Cam - marked M. L.
right Point Cam - marked M. R.

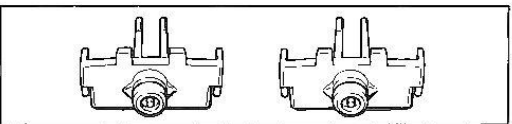

Remove two Edge Pins (orange) from the Accessory Box.

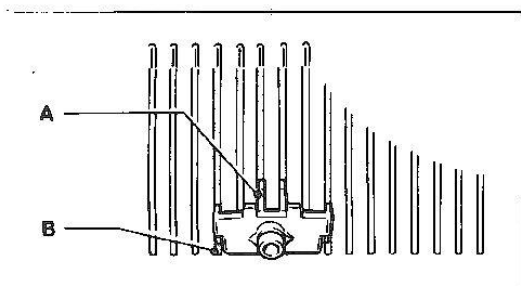
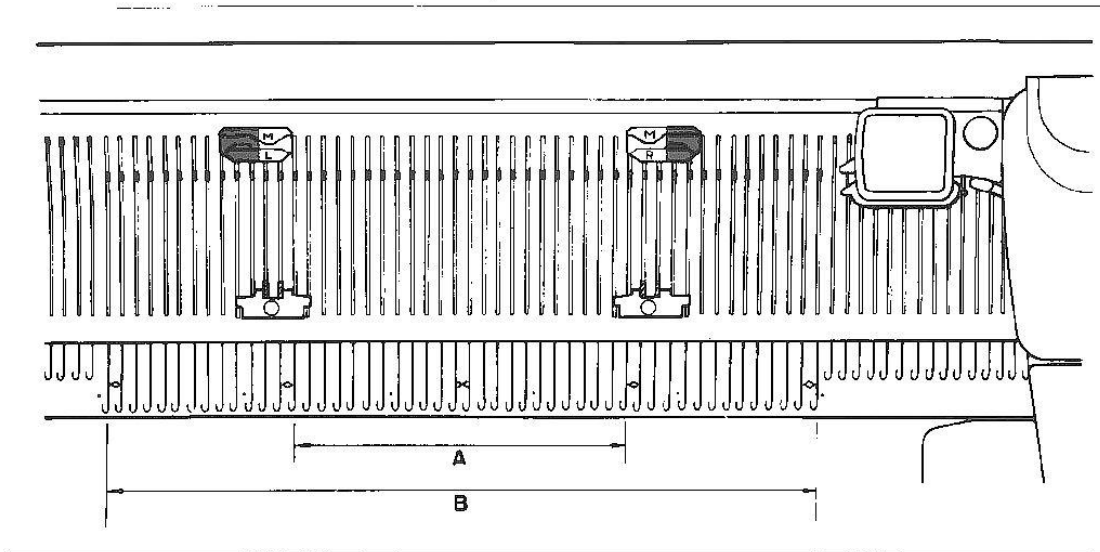

Set the Edge Pins with their knobs between the first and second needles from the last needles knitting single motif lace "A".

B – working needles

(in this case the 13th and 14th needles)

Ensure that the four studs "A" of the Edge Pin fit correctly into the needles groove ends "B", the nearest to you on the Needle Bed.

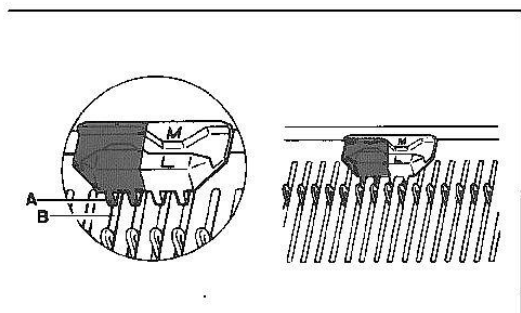

Set the left and right Point Cams M with their division lines (for orange and white) are between the second and third needles from the last needles working single motif lace.

(in this case, the 14th and 15th needles)

Ensure that the four studs "A" of the Point Cam M fit correctly into the needle groove ends "B", the farthest from you on the Needle Bed.

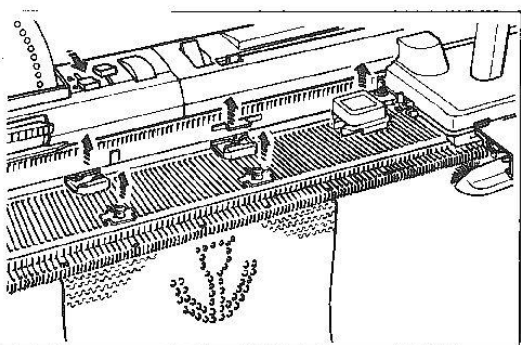

Set the Controls as required in ORDER 2.

Knit 30 rows for single motif lace.

After the single motif lace has been knitted, remove the Magic Cams, Point Cams and Edge Pins.

Set the Stop Knob to ● and continue to knit in stockinet.

HELPFUL HINTS

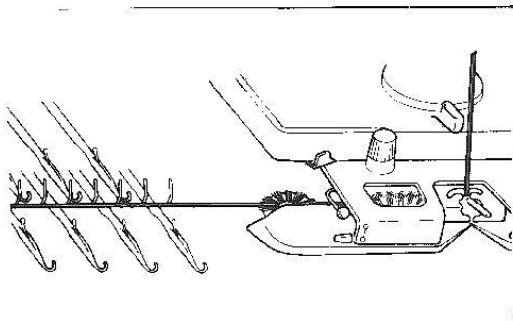

If cast on row is not knitted...

FOR MAIN CARRIAGE

Ensure that the yarn from the Yarn Feeder extends from underneath of the Plastic Round Brush Cover in the Arm to the needles in D position.

If the yarn is PLACED ON THE ROUND BRUSH, it will entangle with the Brush.

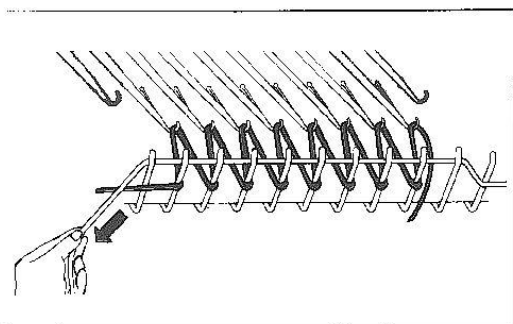

FOR LACE CARRIAGE

Ensure that the Stitch Dial is set to 6 or higher number for the first row. This setting makes large loops between sinker posts and needle hooks, and thus you are able to pull out the Ravel Cord easily. Strain the Ravel Cord laid across big loops before you move the Carriage.

Ensure that the Ravel Cord has been pulled out after knitting 6–7 rows.

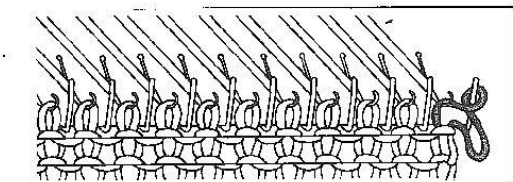

If stitches are dropped or knitted incorrectly...

This can be caused by:

1. bad condition of yarn.
2. moving the Carriage too far past the knitting a row.

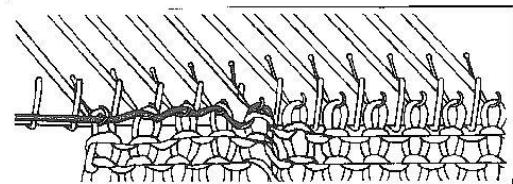

Reform dropped stitches using the Transfer Tool (see page 70) or unravel the row incorrectly knitted. (see pages 66, 67)

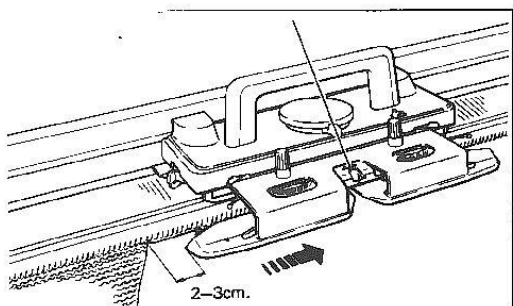

To continue knitting, ensure that:

1. you have passed the last knitting needle by approximately 2–3cm. before knitting the next row.
2. you move the Carriage at an even speed.
3. yarn is in good condition (see page 66).

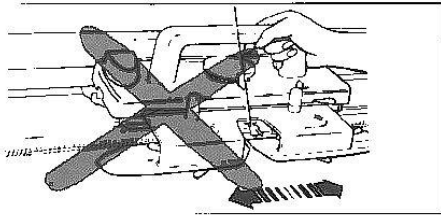

If Carriage has jammed...

In the middle of row, do not force to get the Carriage loose and proceed as follows:—

FOR MAIN CARRIAGE

In pattern knitting, set the Stop Knob to ●, and remove the Magic Cams if they are in use, before moving the Carriage.

Disengage the Row Counter.

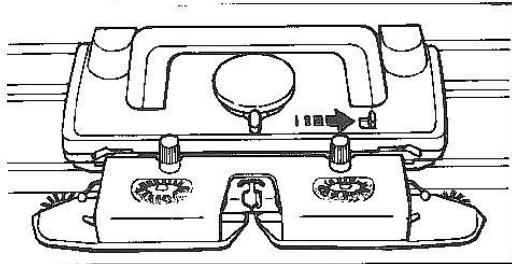

- (1) Remove yarn from the Yarn Feeder.
- (2) Push the Release Lever in the arrowed direction.

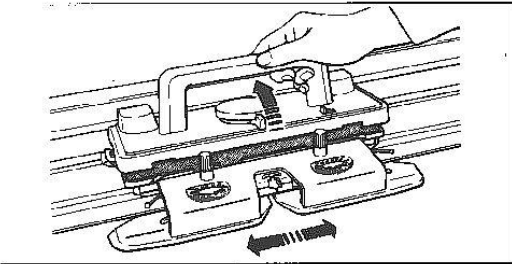

- (3) With the Handle lifted, move the Carriage to the preceding direction until it passes the knitting needles.

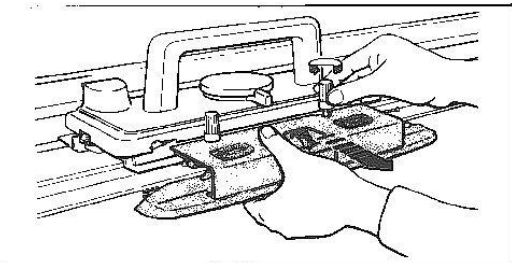

If yarn is entangled with the Yarn Feeder or Arm, loosen the Arm Nuts and remove the Arm. Push the Release Lever and move the Carriage.

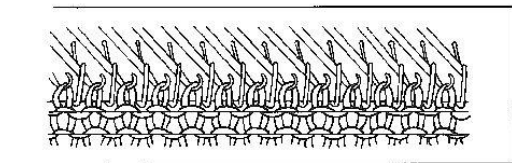

- (4) If stitches have slipped behind the latches of needles, using the Transfer Tool replace these stitches into the needle hooks, unravel the knitted stitches (see page 66, 67) and align the needles in B position.

- (5) Move the Carriage to the yarn side without knitting.

If the Punch Card is in use, let the Carriage memorize pattern. (see page 68)

- (6) Place the Carriage Handle down.
Engage the Row Counter.

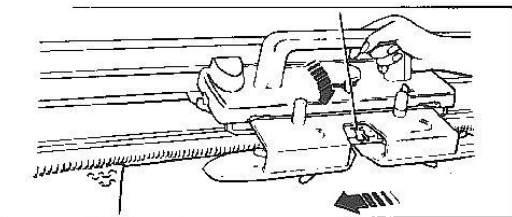

- (7) Insert yarn and continue knitting.

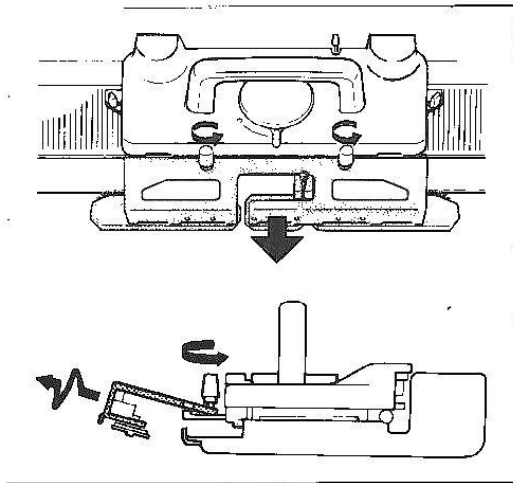

FOR LACE CARRIAGE

In pattern knitting, set the Stop Knob to ● and remove the Magic Cams if they are in use, before moving the Carriage.

- (1) Remove yarn from the Yarn Feeder.
- (2) Loosen the Arm Nuts and pull out the Arm by moving it up and down.

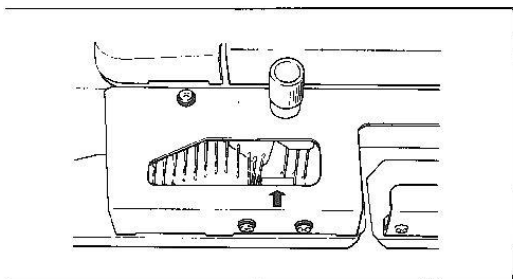

If needle hooks have jammed at the inside of the Arm, remove them using the Transfer Tool.

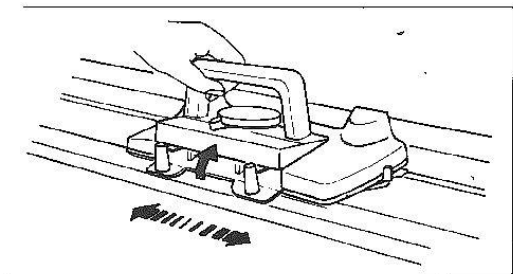

- (3) Cam Lever.....☰
Both Side Levers.....●
- (4) With the Carriage Handle lifted, move the Carriage to the proceeding direction until it has passed the knitting needles.

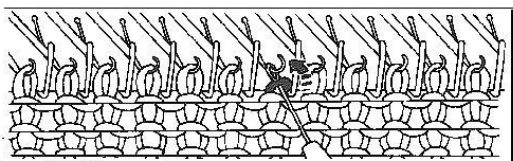

- (5) If stitches have slipped behind the latches of needles, using the Transfer Tool replace these stitches into the needle hooks, unravel the knitted stitches (see page 66, 67) and align the needles in B position.

- (6) Move the Carriage to the yarn side without knitting.

If the Punch Card is in use, let the Carriage memorize pattern (see page 68).

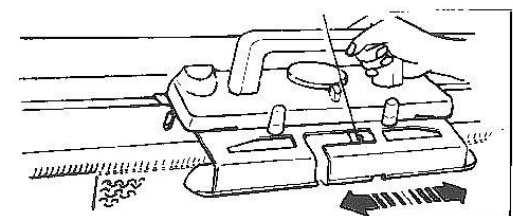

- (7) Place the Carriage Handle down.
Cam Lever.....original position
Both Side Levers.....original position
Stop Knob▼
- (8) Insert yarn and continue knitting.

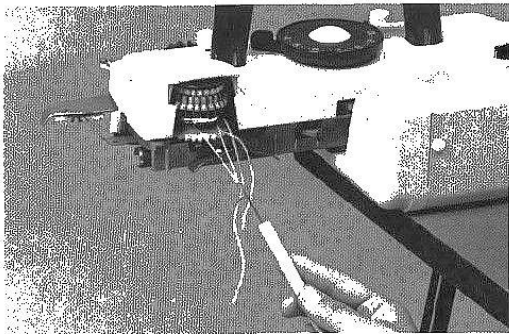

If yarn is entangled in Memory Drums...

Ensure that the rear of the Carriage is clear of yarn.

If yarn does become entangled inside the Memory Drums, move the Carriage to the side of the Needle Bed and carefully remove the yarn using the Tappet Tool.

If this happens during pattern knitting, follow the instruction on page 68 for letting the Carriage memorize pattern.

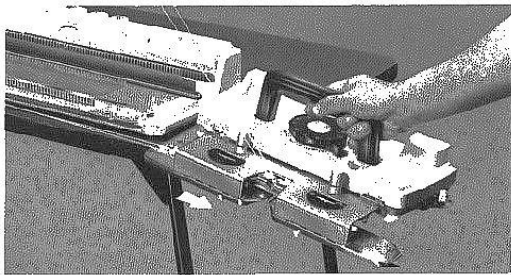

If the Carriage has been pulled out.....

Mount the Carriage to the Needle Bed (see page 43).

If the Punch Card is in use, let the Carriage memorize pattern following instruction on page 68.

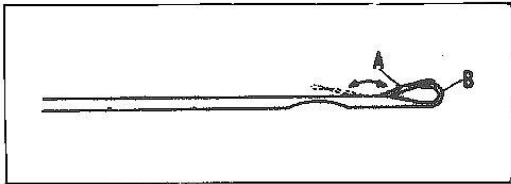

If a needle has been damaged...

A needle with a damaged latch or a bent needle will cause incorrect knitting or dropped stitches.

The needle latch "A" must move smoothly and lie flat over the hook "B".

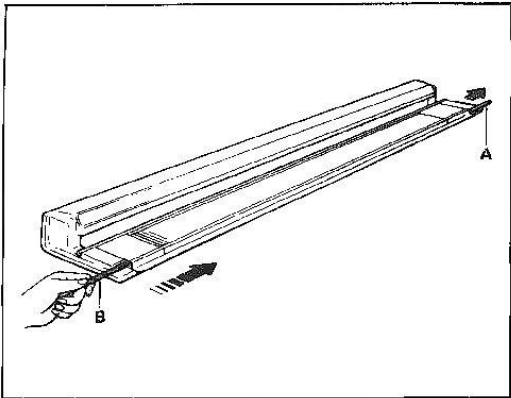

At each side of the Needle Bed you can see the Needle Retainer "A".

If the damaged needle is at the left half of the Needle Bed, using a pencil "B" push the Needle Retainer at its left plastic end.

If the Yarn Separator is in use, remove it before removing the Needle Retainer.

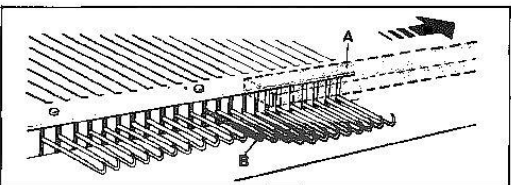

The Needle Retainer is then pushed out of the Needle Bed at the right and you can pull it out of the Needle Bed until the damaged needle lies free.

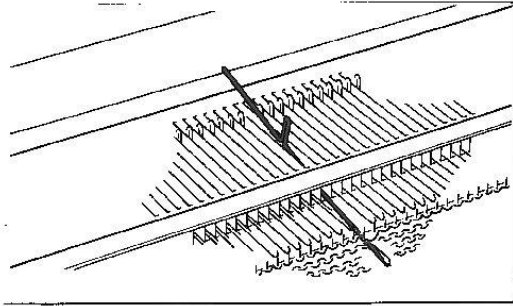

Push the damaged needle to D position by pressing its butt. Close the latch "A" and press the hook "B" down. The shank "D" will then come out of the needle groove "E".

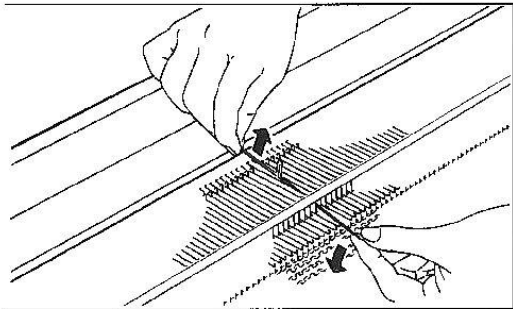

Lift up the needle by holding the shank and pull it to remove from the Needle Bed.

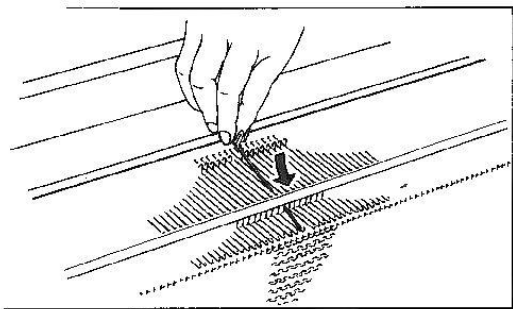

To replace a new needle, open its latch and slide it into the Needle Bed groove until the hook "B" comes out of the front opening of the Needle Bed. Push the needle back to A position by holding the butt.

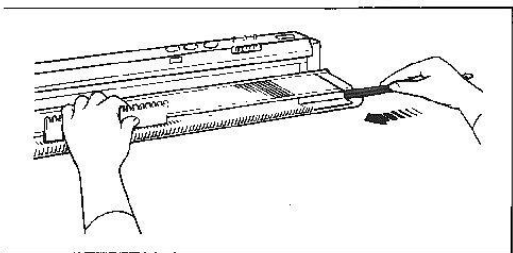

Insert the Needle Retainer back into the Needle Bed by holding its right end. To insert the Needle Retainer, press the floated needles to the front edge of the Needle Bed using the Needle Pusher.

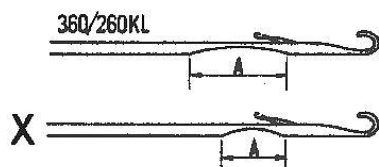

As a needle for Model 360/260KL is completely different from the needles of other Models in its bored diameter "A", when replacing or ordering the needle, be sure to specify its Part No.01130616.

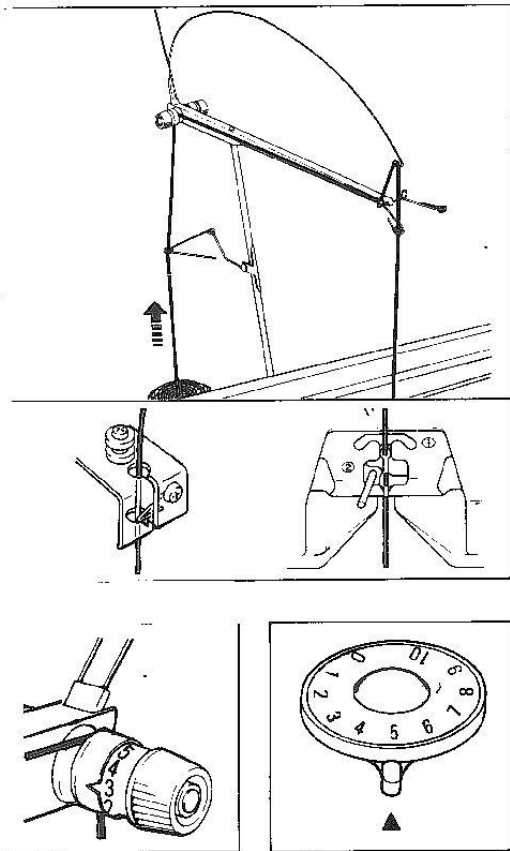

Checking yarn condition

Check of yarn is required when:

1. cast on row is not knitted.
2. stitches have dropped or knitted incorrectly.
3. Carriage has jammed.

CHECK THE FOLLOWING POINTS:—

- (1) Ensure that yarn is properly threaded into the Auto Tension and Yarn Feeder.
- (2) Ensure that the Tension Spring is nearly in the horizontal position.
- (3) Ensure that yarn does not have a knot.
- (4) Ensure that yarn comes freely from yarn ball.
- (5) Ensure that the Tension Dial and Stitch Dial numbers are selected correctly.

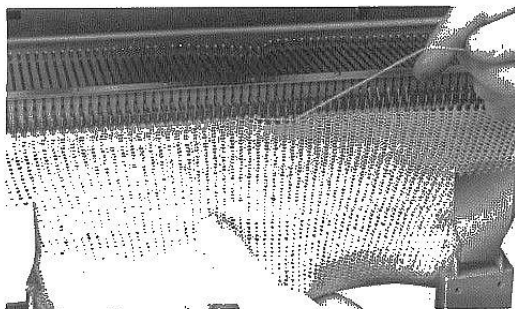

To unravel the knitting

Unravelling is required when:

- you have knitted too many rows.
- you have made a mistake in your knitting.
- Carriage has jammed.
- stitches have dropped or knitted incorrectly.

TO UNRAVEL, PROCEED AS FOLLOWS:—

Remove the Carriage from the knitting before you start to unravel. (If the Carriage has jammed, see page 62.)

Remove yarn from the Yarn Feeder.

Hang the Claw Weights on both edges of the knitting.

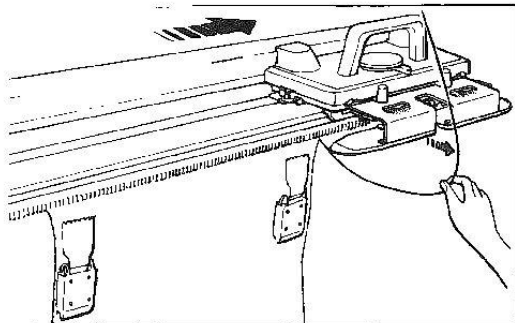

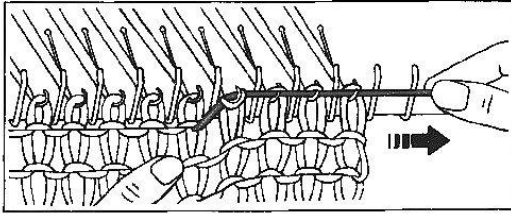

Holding the knitting downwards with your left hand, pull yarn sideways.

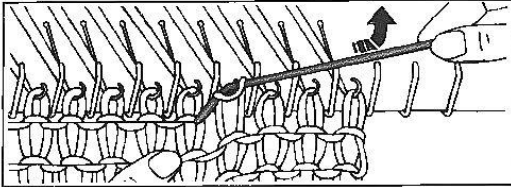

Lift the yarn upwards and very slightly backwards. The stitches of previous row slide back onto needle hooks.

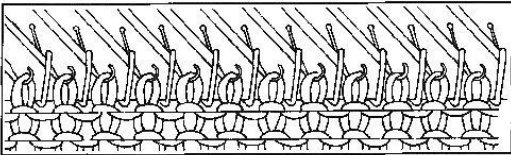

Ensure all stitches are in the needle hooks and the needles are in B position.

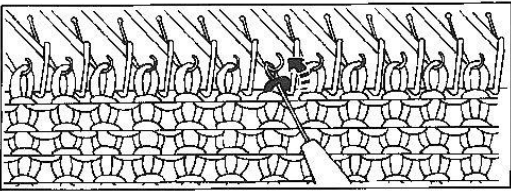

If some of stitches are not in needle hooks, place them into the hooks using the Transfer Tool.

Repeat the above procedure until the required number of rows have been unravelled.

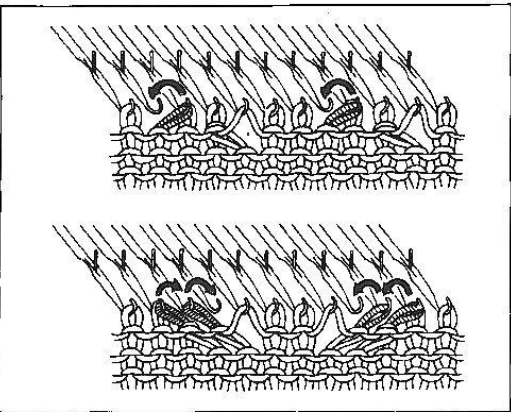

NOTES FOR UNRAVELLING

In case of using L KNOB, unravel an even number of rows.

In case of LACE KNITTING, place the transferred stitches back to their original needles before unravelling the row. (Illustration)

NOTES FOR RE-KNITTING

Return the Row Counter by the same number of rows unravelled before re-knitting.

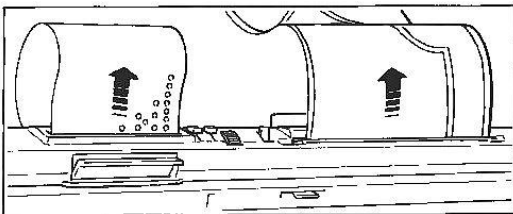

In case of using the PUNCH CARD, return the Card and let the Carriage memorize the pattern before re-knitting. (see page 68).

In case of using the KNIT CONTOUR, return the Pattern Paper before re-knitting. (see page 23 of the Knitting Manual.)

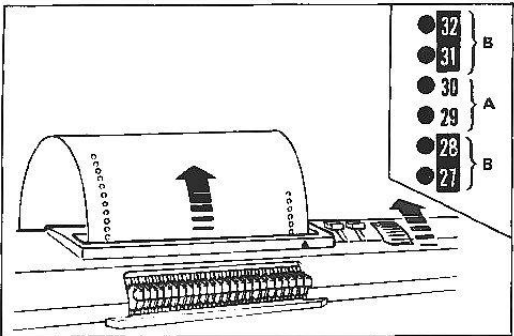
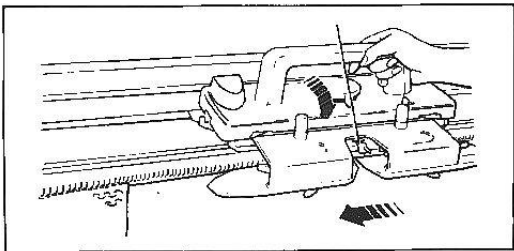
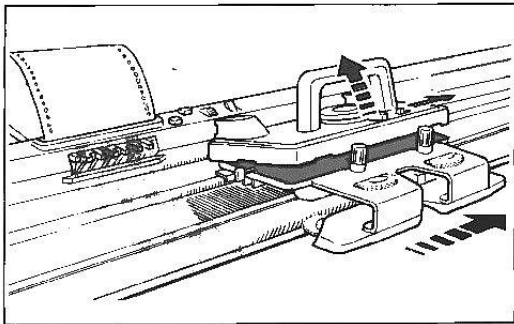
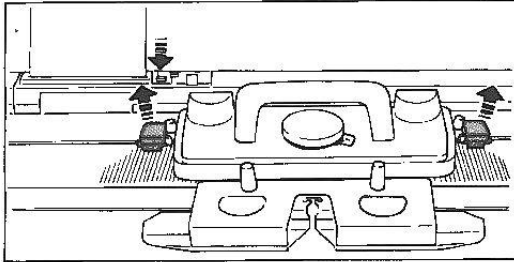
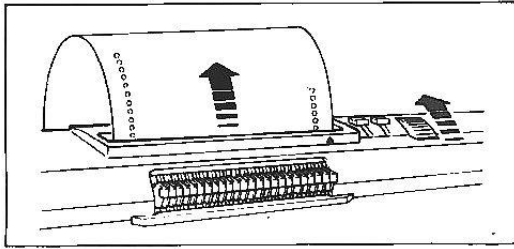

To memorize the pattern

Memorizing the pattern is required when:

1. Carriage has been pulled out from the Needle Bed.
2. unravelling has been done.

FOR MAIN CARRIAGE

If unravelling has been done, return the Punch Card and Row Counter by the same number of rows unravelled.

In case of using L KNOB, return the Punch Card ONLY HALF THE NUMBER of rows unravelled.

*For example: 3 rows incorrectly knitted.
Unravel 4 rows.
Return the Card only 2 rows.*

Set the Stop Knob to ● and remove the Magic Cams if they are in use.

Disengage the Row Counter.

Remove yarn from the Yarn Feeder.

Push the Release Lever to the right and with the Carriage Handle lifted, move the Carriage one or twice across the Needle Bed until it has passed the 24 needles corresponding to the Touch Levers "A" and place it at the side of yarn.

Insert yarn into the Yarn Feeder and set the Controls to their original positions.

Continue to knit.

FOR LACE CARRIAGE

If unravelling has been done, return the Punch Card and Row Counter by the same number of rows unravelled.

When the Punch Card for Fashion Lace (L-9 and L-10) is in use, return the Card by the same numbers unravelled over the Card Memory Numbers "A" skipping the marked Card Memory Numbers "B". "B" is not knitted rows but rows for transferring stitches.

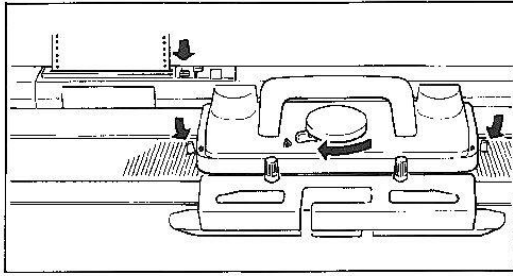

- Stop Knob●
- Cam Lever.....☰
- Both Side Levers.....●

Remove yarn from the Yarn Feeder.

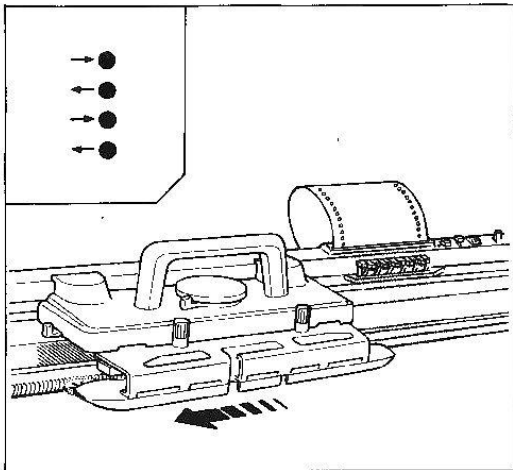

Move the Carriage once or twice across the Needle Bed until it has passed the 24 needles corresponding to the Touch Levers "A" and place it at the side of yarn.

NOTE

Ensure that the arrow mark on the Punch Card corresponds with the Carriage proceeding direction.

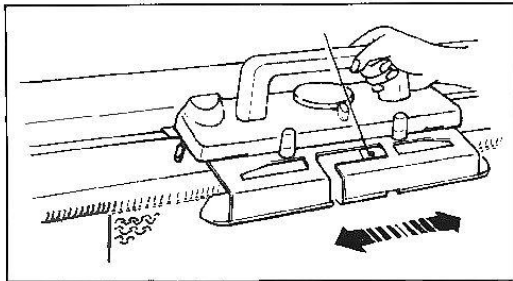

Insert yarn into the Yarn Feeder and set the Controls to their original position.

Continue to knit.

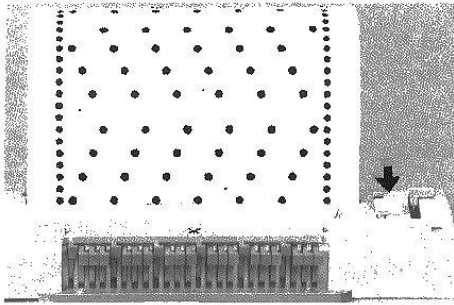

TO LOCATE PATTERN ON PUNCH CARD

To locate pattern of the Punch Card to be knitted on the next row, set the Stop Knob to ●.

The Touch Levers are aligned in two positions.

- upper position perforated area
- lower position..... non-perforated area

To locate the pattern on the last knitted row, return the Punch Card by one row before setting the Stop Knob.

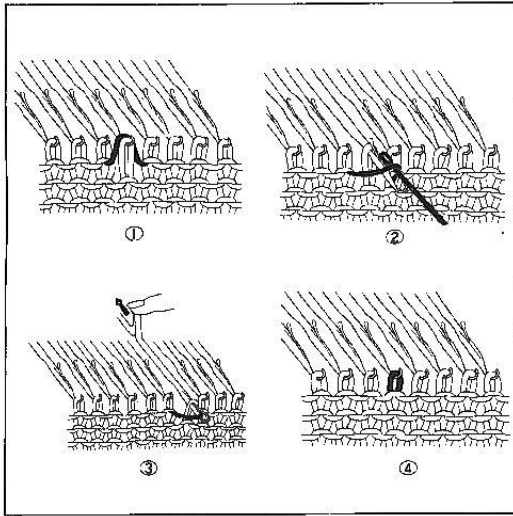

To reform stitch

Reforming stitch is required when the stitches have dropped while knitting.

A DROPPED STITCH

- (1) Insert the One-Eye Transfer Tool into a stitch below the dropped stitch and replace it into needle hook together with loose yarn.
- (2) Slowly pull the needle out until the stitch is behind the open latch leaving the loose yarn in the hook.
- (3) Push the needle back so the latch will close and the stitch behind will slide over the hook reforming a stitch.

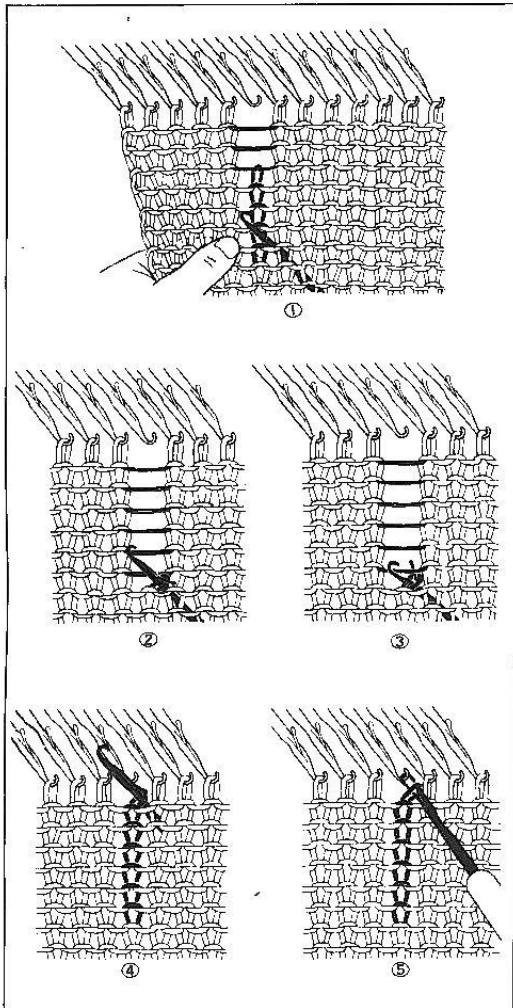

STITCHES DROPPED IN SEVERAL ROWS

- (1) Insert the Tappet Tool into a stitch a few rows below the dropped stitch from the side away from you. Unravel the stitches down to the Tool.

With the other hand, pull the knitting downwards. This makes unravelling easier.

- (2) Push the Tool toward you so the stitch will be behind the open latch. Catch the yarn crossing above into the hook.
- (3) By pulling the Tool backwards, the latch will close and the loose yarn will be trapped in the hook.
- (4) Continue pulling and the old stitch will slide down over the closed latch forming a new stitch in the hook.
- (5) Repeat this operation up to the top.

If one or more stitches have dropped or when pattern knitting using the Punch Card, we recommend you to unravel than to reform stitches. (see page 66, 67)

MAINTENANCE

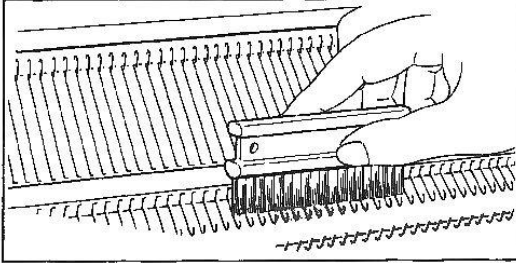

To clean your Knitter, remove the Carriage from the Needle Bed.

NEEDLE BED

Remove all lints using the Cleaning Brush.

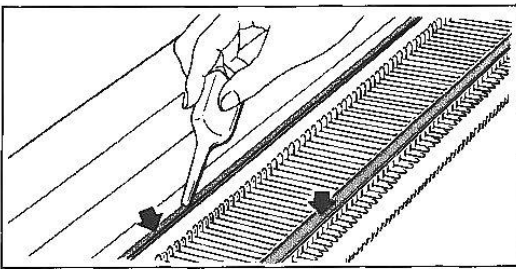

Apply oil along the rail and front guide of the Needle Bed.

With an oiled soft cloth, wipe needle butts.

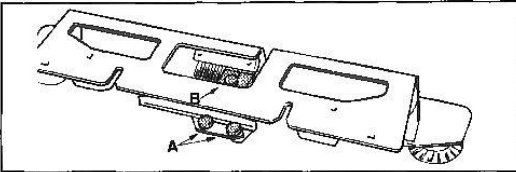

CARRIAGE AND ARM

Turn the Carriage upside down, remove any lints that may be around the round brushes of the Main Carriage Arm or the rollers "A" and Yarn Feeder "B" of the Lace Carriage Arm.

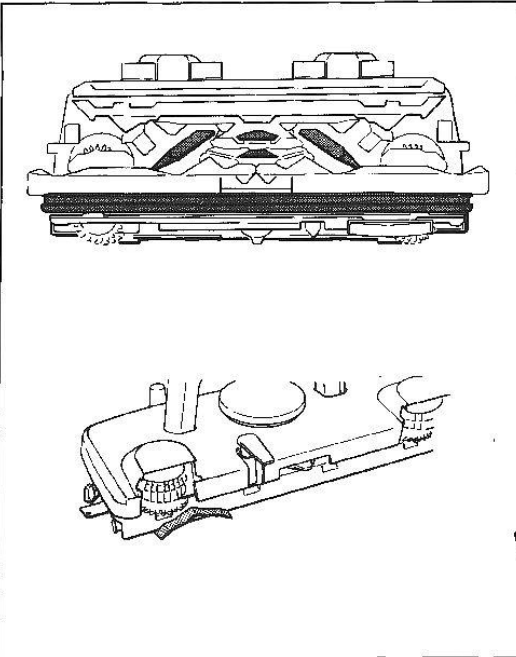

Apply oil to the metal parts at the back of the Carriage and Arm.

The metal parts "C" of the Lace Carriage Arm must be handled very carefully.

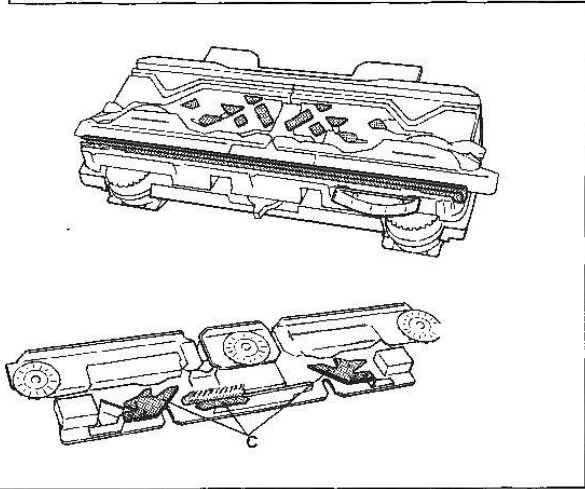

REPACKING THE KNITTER

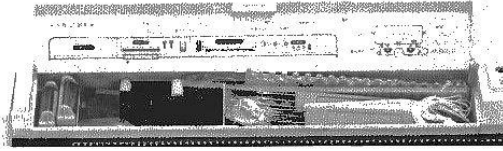

Replace the Accessories in the Accessory Box.

Remove the Punch Card from the Pattern Card Panel.
Do not fold or bend it.

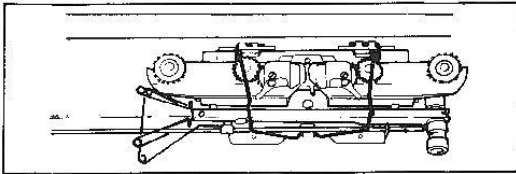

Remove the Auto Tension and Arm from the Knitter and pack them inside the Top Cover.

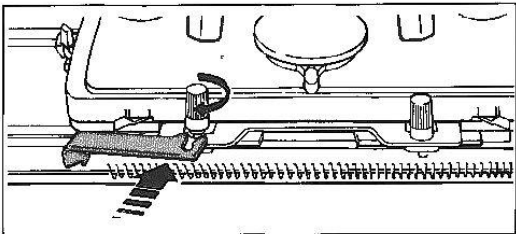

Secure the Carriage to the Needle Bed with the Carriage Fastener.

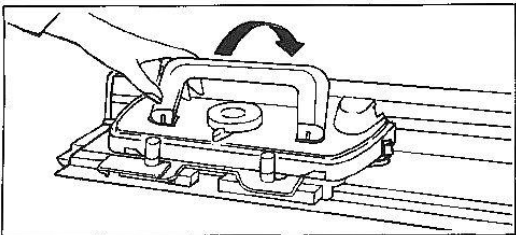

Lay the Carriage Handle down.

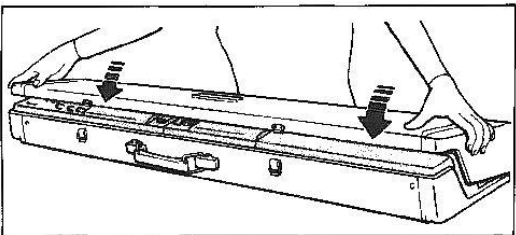

Place the Cop Cover onto the Needle Bed.

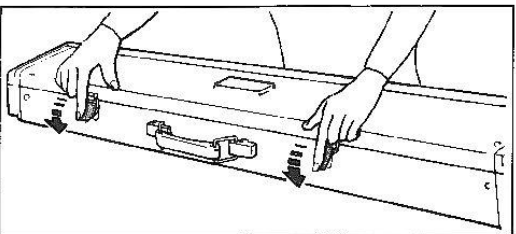

Fasten the latches.

Store the Knitter in a dry place.

INDEX

(M) – Main Carriage
(L) – Lace Carriage
K/M – Knitting Manual

A

Arm 7(M) 43(L)
Arm Nuts 4, 7(M) 44(L)
Automatic Linker 44
Auto Tension 8
Auxiliary Feeding Cam 42, K/M

B

Basic knitting techniques . . . 15, 16, 17, 18(M) 50, 51(L)
Butt 10

C

Cam Lever 6, 11(M) 43, 45(L)
Card memory number 23(M) 54, 58(L)
Card Guide 2, 22
Card Snap 2, 22
Carriage Fastener 2, 4
Cast on 11(M) 45(L)
Clamp 2, 7
Claw Weight 2, 24, 39
Cleaning Brush 2, 71
Comb Weight 43, 55
Crochet Hook 2, K/M

D

Decreasing 17
Dropped stitch 70

E

Edge Pin 43, 56, 59

F

Fair Isle (Knit-in) 25
Fashion Lace 57

G

Gauge Scale 2, K/M

H

Hand feeding 42
Helpful hints 61
Hook 10

I

Increasing 18(M) 51(L)
Incorrect knitting 66

J

Jam in knitting 62(M) 63(L)

K

Knit Contour (Radar) 1, K/M
Knit-in 25
Knitting yarns 14(M) 49(L)

L

Lace Carriage 43
Lace knitting 54
Latch needle 10
L Knob 26
L Knob Indicator 26

M

Magic Cams 2, 37, 59
Main Carriage 5, 6
Main knitting 42
Main yarn 9
Maintenance 71
Marked card memory number 58
Memorizing pattern 68
Moving Carriage without knitting 68(M) 68, 69(L)

N

Needle arrangement 23, 31
Needle Pusher 2, 10
Needle Retainer 64
Nylon thread 32

O

Oil 2, 71
Operation table 23(M) 54(L)

P

Pattern Card Panel 26
Pattern knitting 21(M) 54(L)

P

Pattern Paper	2, K/M
Plain lace	56
Plating	35
Plating Yarn Feeder	36
Point Cams M	2, 38, 59
Punch Card	21(M) 54(L)
Punch Card Feeding Dial	22
Punch Lace	32

R

Ravel Cord	2, 42, 47
Reforming stitches	70
Release Lever	5, 62, 68
Removing fabric	19(M) 52(L)
Repacking the Knitter	72
Replacing a damaged needle	64
Ribber Join Screws	43, 44
Ribber Needle Bed Cover	44
Row Counter	5, 6
Row Counter Set Lever	5
Row Counter Triper	6
Russel Levers	5, 6

S

Second yarn	9
Side Levers	5, 6
Single motif	37(M) 59(L)
Sinker post	46
Skain Holder	3
Slack yarn	16, 20
Slip stitch pattern	27
Stitch Dial	11, 14(M) 45, 48(L)
Stitch Scale	2, K/M
Stitch size	14(M) 48(L)
Stockinet knitting	11(M) 45(L)
Stop Knob	5
Stop Net	32
Stripe pattern	15

T

Tapestry Needle	2
Tappet Tool	2, 70
Tension Dial	9
Threading Auto Tension	9
Threading Yarn Feeder	12(M) 45(L)
Touch Levers	5, 24
Transfer Tool	2, 17
Tuck Knob	7, 29
Tuck stitch pattern	29

U

Unravelling	66
-------------	----

W

Weaving	33
Weaving Knob	7, 33
Weaving Yarn Holder	7, 33
Weight	2, 24, 39

Y

Yarn Ball Winder	3
Yarn change mark	40
Yarn Clip	9
Yarn Feeder	7(M) 45(L)
Yarn Holders	47
Yarn preparation	3
Yarn Rod	2, 8
Yarn Separators	2, 38

