

OPERATION MANUAL

MOD. 550

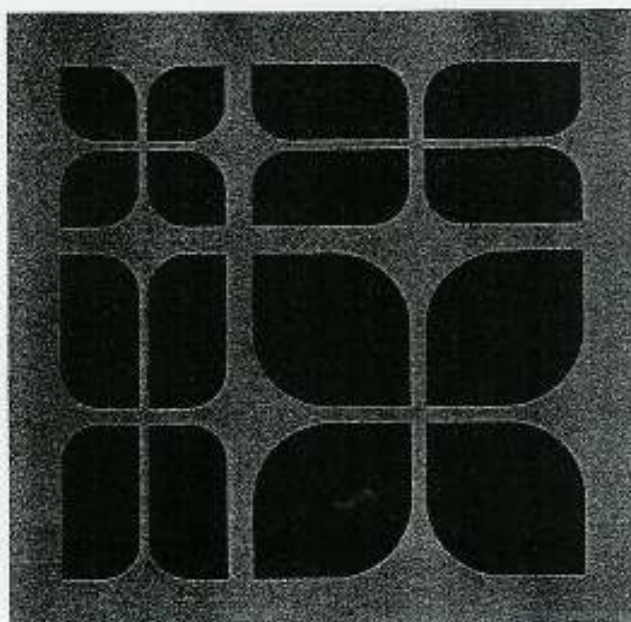
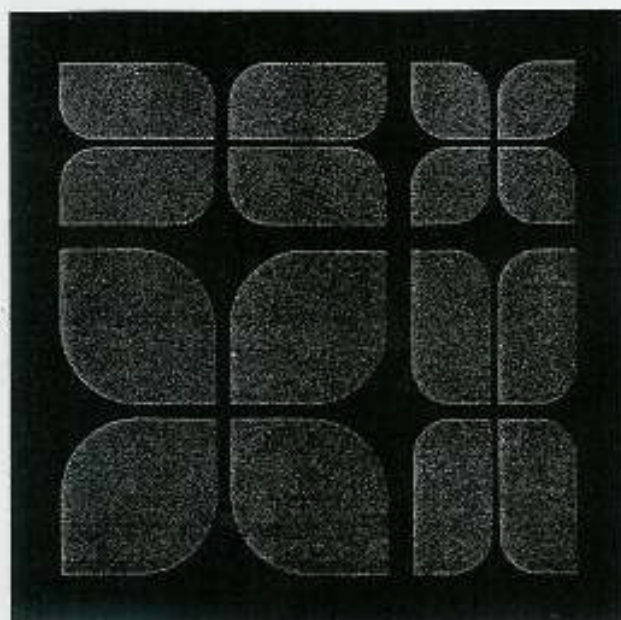
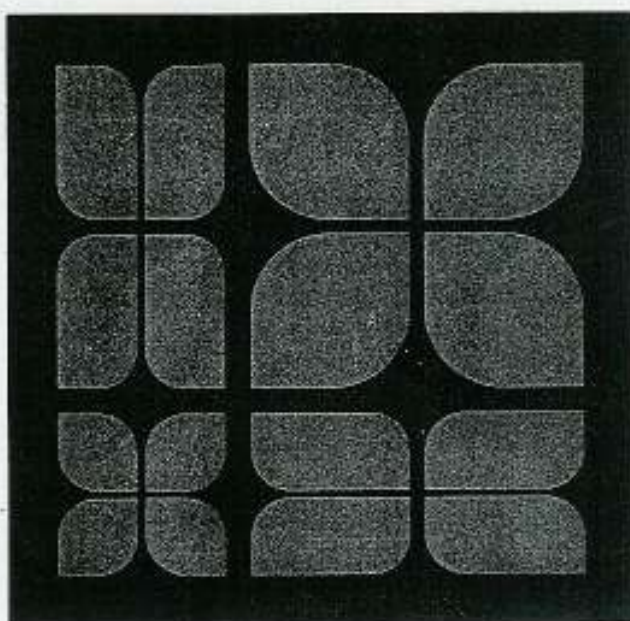
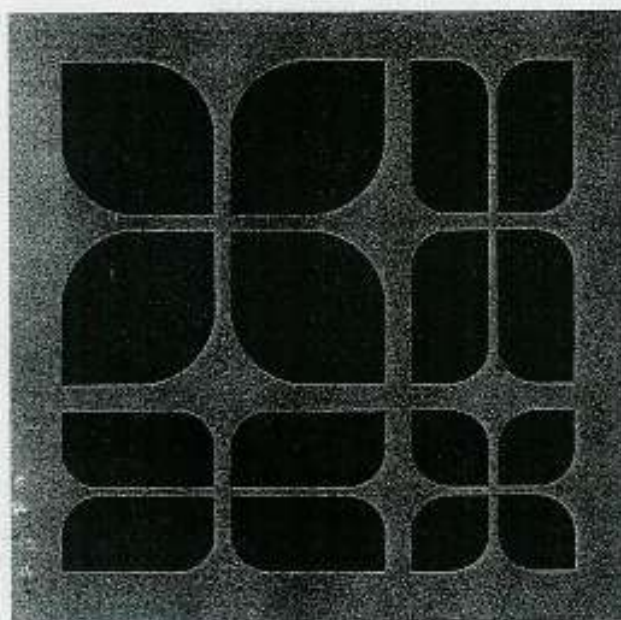

OPERATION MANUAL

MOD 550

Congratulations on your purchase of this technologically advanced and sophisticated knitting machine.

This Operation Manual is divided into sections — for the knitting machine, its combination with the Ribber, and with the Automatic Yarn Changer. So refer to the section according to the combination of the machine you own.

It is strongly advised to read this manual thoroughly so as to avoid any misuse of this machine, and which may cause the machine to be damaged irreparably.

Extensive use of this machine will be sure to satisfy your creativity in knitting and will invite you into the broader world of machine knitting.

MODEL 550 KNITTING MACHINE

pages 1—48

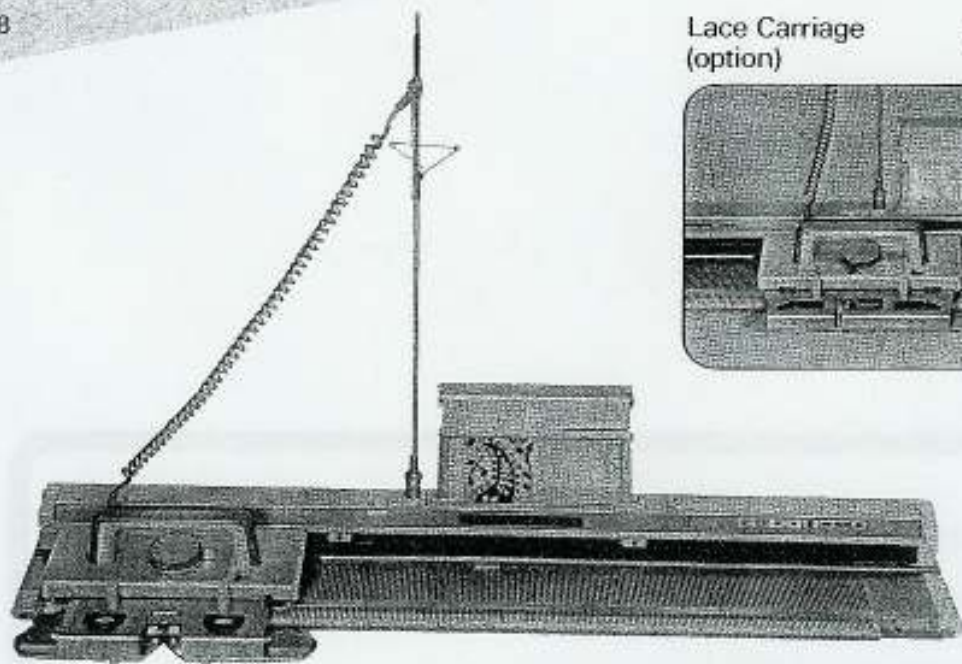

Lace Carriage
(option)

pages 34—48

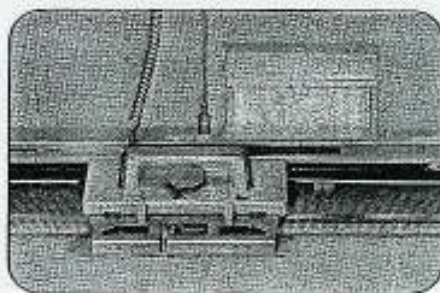

MODEL 550 WITH RIBBER

pages 49—97

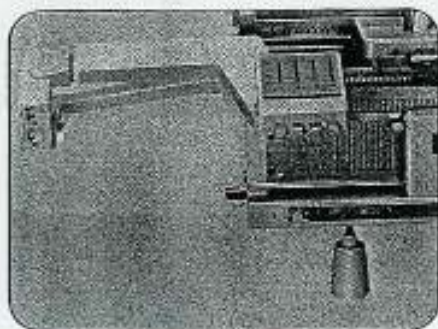

Automatic Yarn Changer

pages 86—96

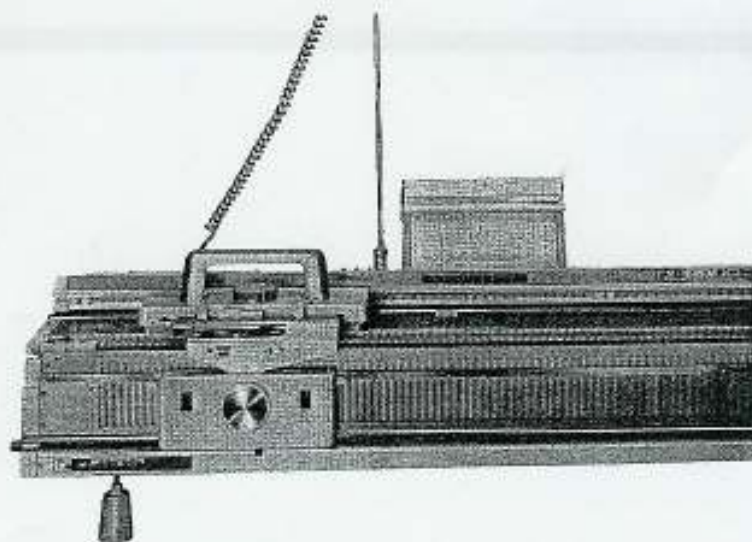

TECHNICAL HINTS

pages 98—114

PRECAUTION

This machine must be kept away from the following places since electronic components are vulnerable to those conditions.

1. Direct and strong sun light.
2. Near to heater, or a place of excessively high temperature.
3. Excessively humid or dusty.

When the machine is not in use, disconnect the plug from the A.C. mains, otherwise the Transformer continues to consume electric power even if the ON-OFF switch is turned off.

TO USE THE KNITTER

CONTENTS

	page
YARN PREPATION FOR KNITTING	2
SETTING UP THE KNITTER	3
GET TO KNOW THE NAMES OF THE FUNCTIONAL PARTS	5
ACCESSORIES	6
THREADING THE AUTO-TENSION	8
NEEDLE AND NEEDLE POSITIONS	9
CAM LEVER AND STITCH DIAL	10
CAST-ON AND STOCKINET KNITTING	11
REMOVING THE FABRIC FROM THE MACHINE	14
PATTERN CARD	15
PATTERN CONTROLS	16
PREPARATION FOR PATTERN KNITTING	19
Setting up the machine for pattern knitting	19
Setting the Card Stand and Pattern Card	20
Setting the pattern controls	21
KNIT-IN (FAIR ISLE)	23
SINGLE MOTIF	24
TUCK STITCH	26
SLIP STITCH	28
TUCK/SLIP STITCH PATTERN IN COLOURS	29
WEAVING	30
PLATING	32
PUNCH LACE	33
LACE CARRIAGE	34
SETTING THE LACE CARRIAGE ON THE NEEDLE BED	35
CAM LEVER AND STITCH DIAL	36
CAST-ON AND STOCKINET KNITTING	37
KNITTING LACE STITCH PATTERNS	41
PLAIN LACE	43
FASHION LACE	44
SECTIONAL PATTERNING	46
REPACKING THE KNITTER	48

YARN PREPARATION FOR KNITTING



Choose a yarn of suitable thickness according to the type of knitting. For knitting on the Knitter, 4 ply is recommended (② — ③ in diagram). When the Ribber is connected, 2 — 3 ply is recommended. (① — ③ in diagram.)

Correct preparation of the yarn is a very important step to ensure smooth knitting.

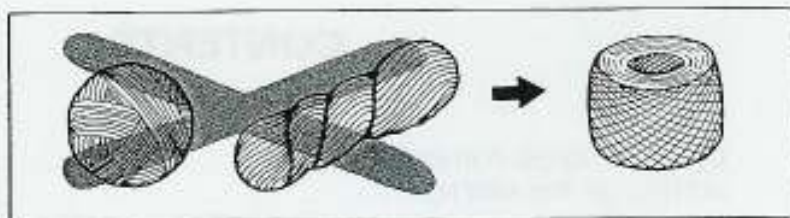
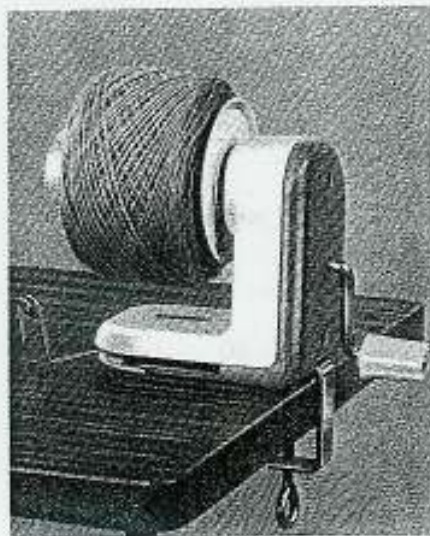

It is not possible to knit from a hank of yarn or hand wound ball, as for machine knitting it is essential for the yarn to feed into the machine freely. Place the hank onto your arms or a Skein Holder and wind into a ball using the Yarn Ball Winder.

The Skein Holder and Yarn Ball Winder are optional accessories.

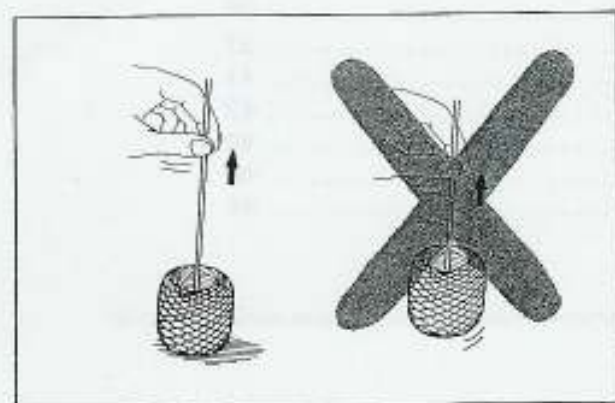
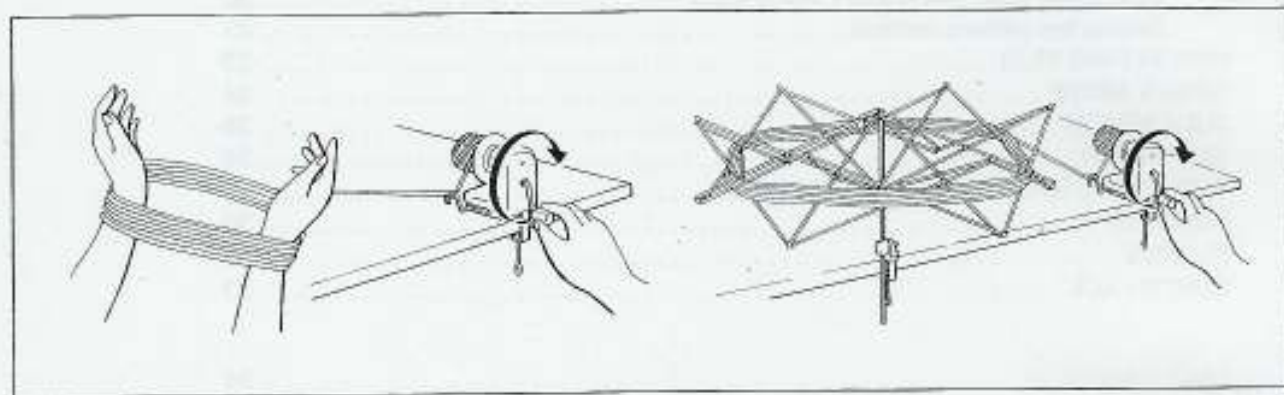

When yarn is rewound, ensure that the yarn end comes out freely without lifting the ball from the table.

We recommend that you either wax the yarn during winding.

SETTING UP THE KNITTER

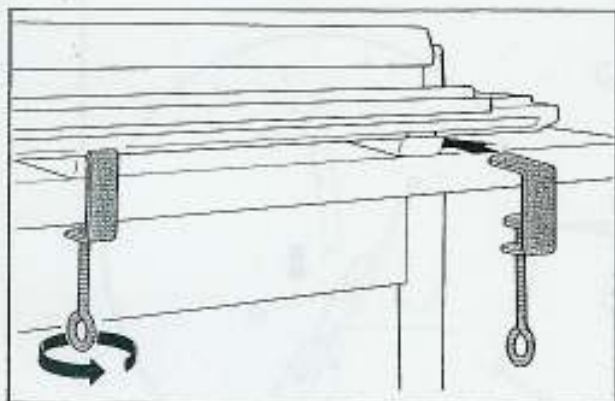
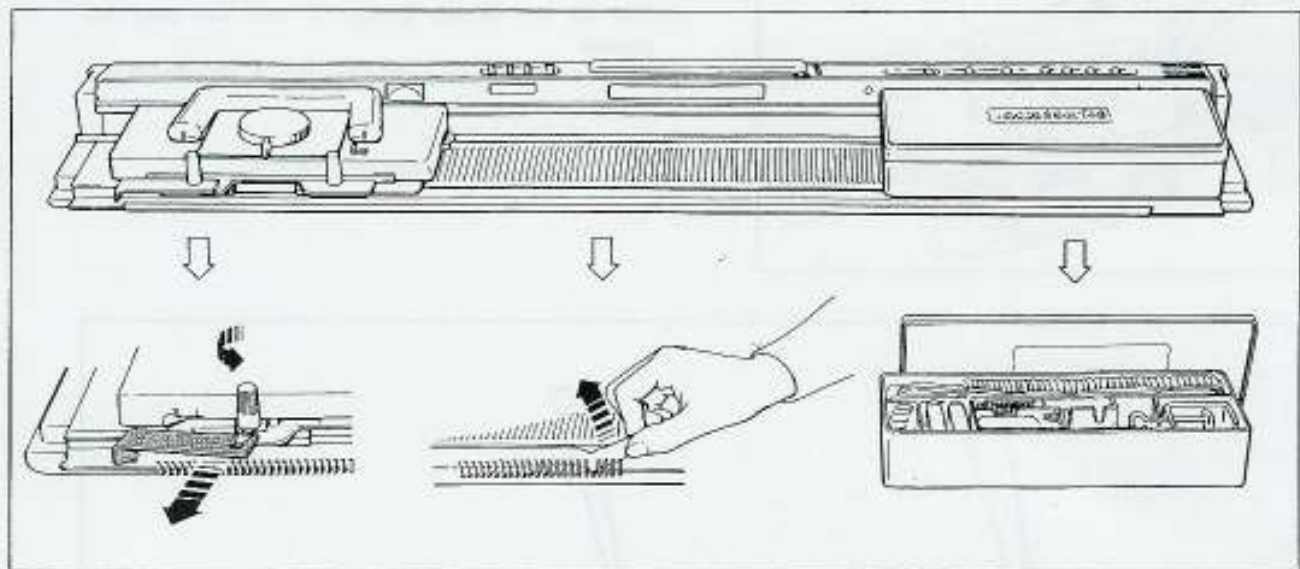
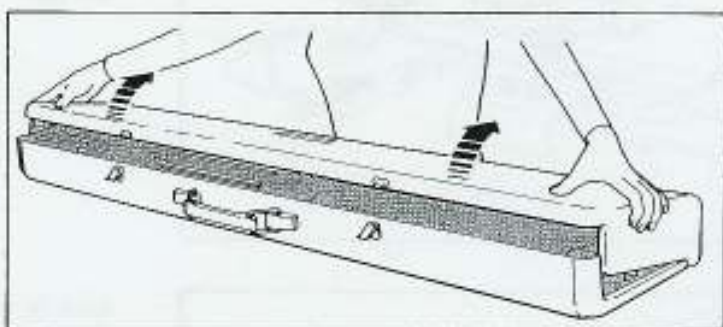
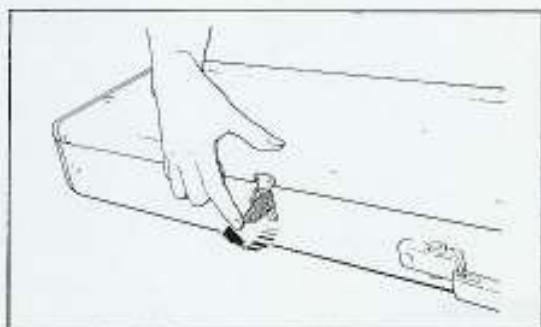

Place the machine on the table with its Carrying Handle away from you, and open the machine as illustrated above.

Open the Accessory Box, and take out two Clamps, and secure the Knitter to the table.

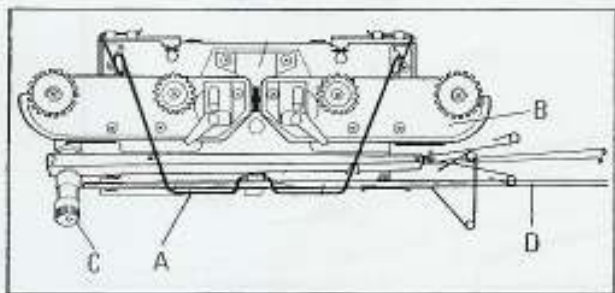

Release the Wire Spring "A", and take out the Arm "B", Auto-Tension "C" and Yarn Rod "D".

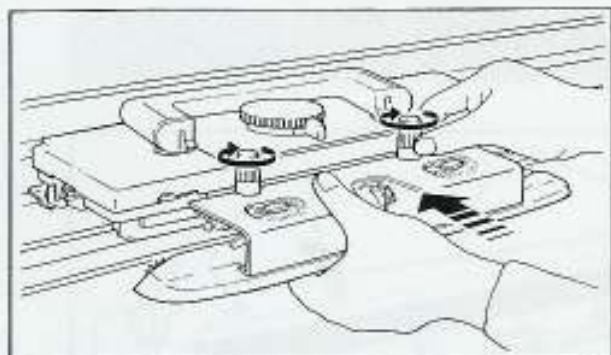

Loosen the two Arm Nuts, and insert the Arm under them.

Push the Arm as far as it goes and tighten them in the arrowed direction.

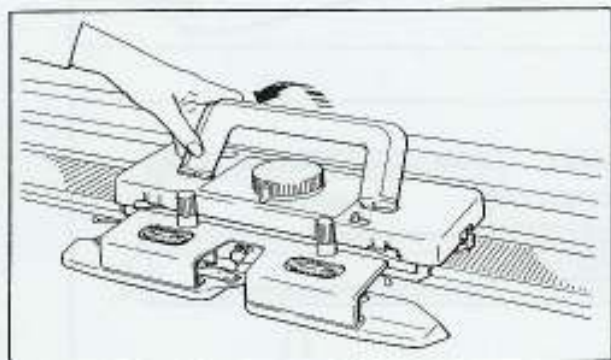

Raise the Carriage Handle.

Set the Auto-Tension and Yam Rod on the machine as follows.—

- ① Turn the two Tension Springs "E" until they snap into position.
- ② Insert the short bent end of the Yam Rod "F" into the left side handle bracket socket "G".
- ③ Raise the Tension Guide.
- ④ Place the Auto-Tension onto the Yam Rod.

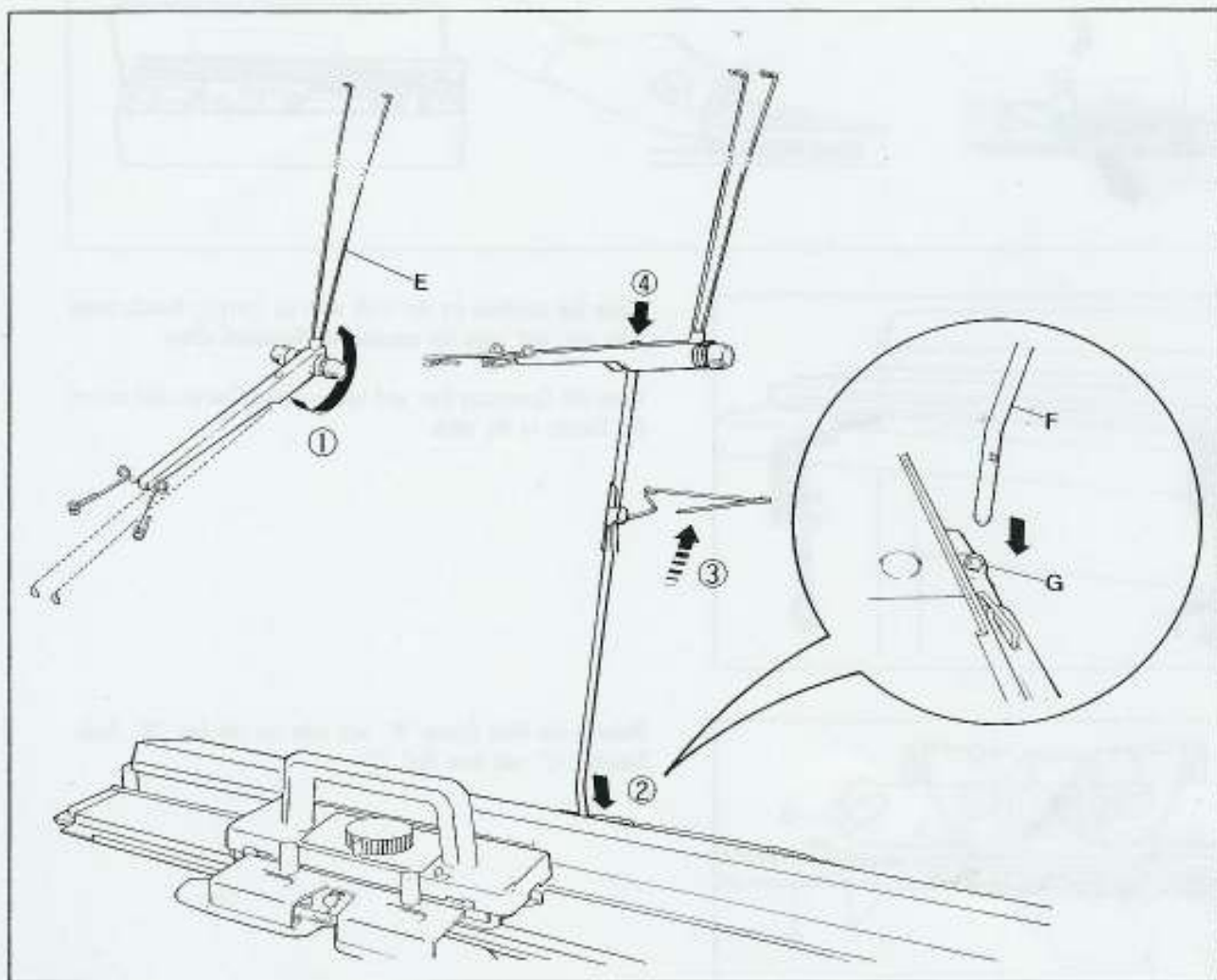

GET TO KNOW THE NAMES OF THE FUNCTIONAL PARTS

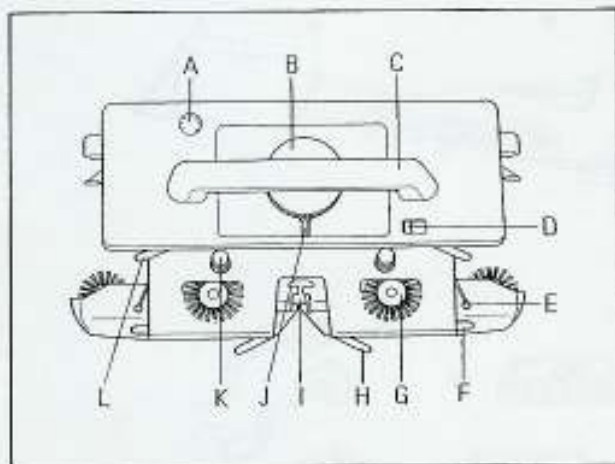
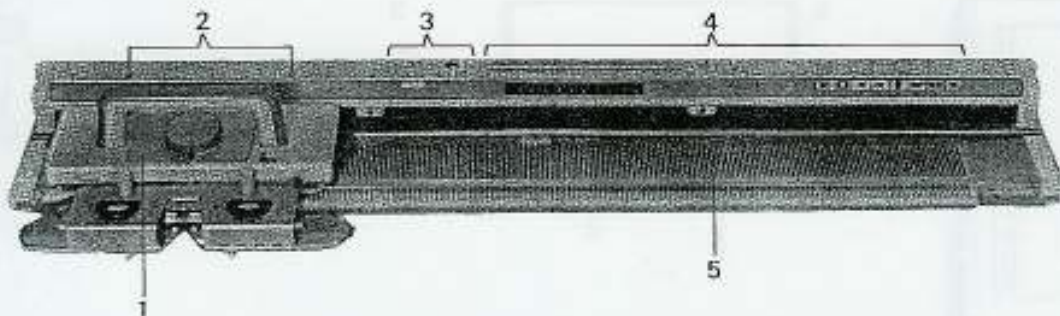

1. STANDARD CARRIAGE (with Arm)

- A — Curl Cord Socket
- B — Stitch Dial
- C — Handle
- D — Release Lever
- E — Weaving Yarn Holder
- F — Weaving Knob
- G — Weaving Brush
- H — Tuck Lever
- I — Yarn Feeder
- J — Cam Lever
- K — Arm Nut
- L — Russel Lever

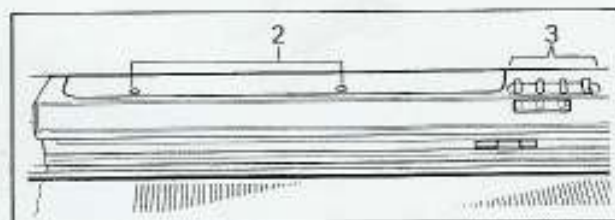

2. KNIT CONTOUR (RADAR) SECURING STUDS

3. ROW COUNTER

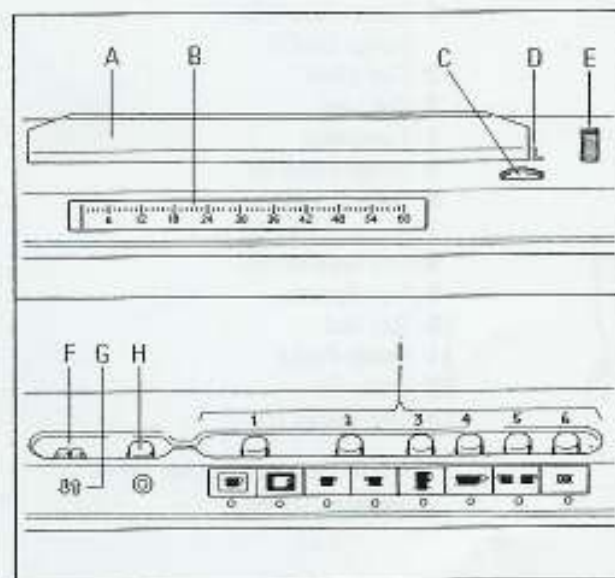

4. PATTERN PANEL

- A — Card Cover
- B — Pattern Width Indicator
- C — Pattern Width Dial
- D — Card Slot
- E — Card Dial
- F — Card Buttons
- G — Feeding Direction Pointer
- H — Inspection Button
- I — Pattern Buttons (1 — 6)

5. NEEDLE BED

ACCESSORIES

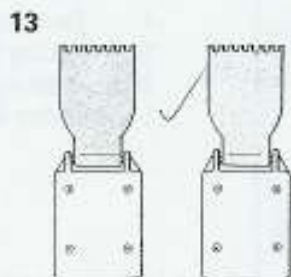
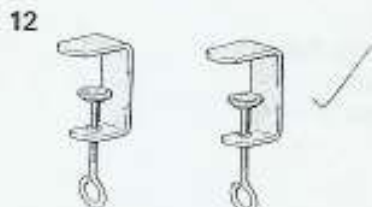
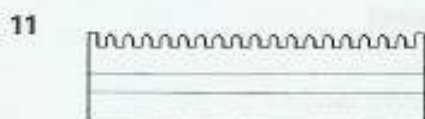
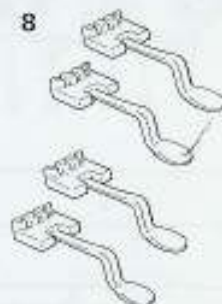
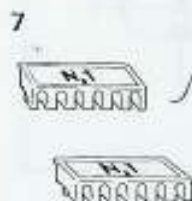
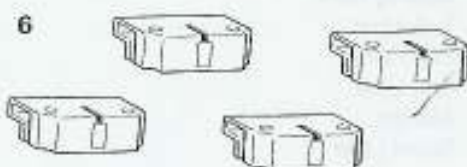
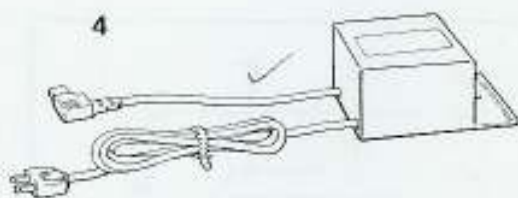
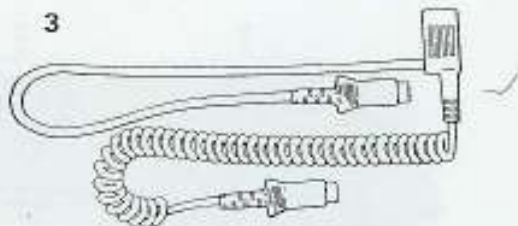
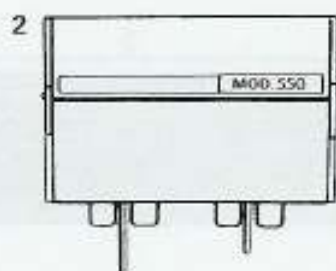
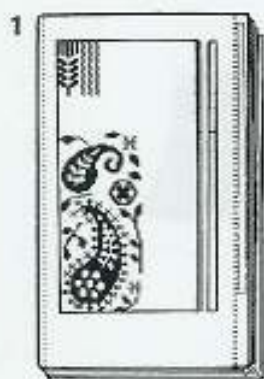

Numbers in brackets refer to quantity.

- 1 Pattern Card (15)
- Design Card (5)
- 2 Card Stand
- 3 Curl Cord
- 4 Transformer
- 5 Design Pencil (2)
- 6 Point Cam (4)*
- 7 Needle-1 Cam (2)
- 8 Yam Separator (4)
- 9 Auto-Tension
- 10 Yam Rod
- 11 Needle Pusher
- 12 Clamp (2)
- 13 Claw Weight (2)

* Two on the needle bed and two in the accessory box.

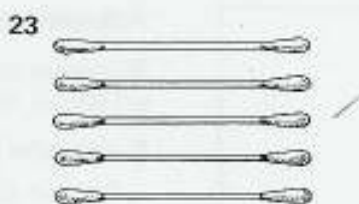
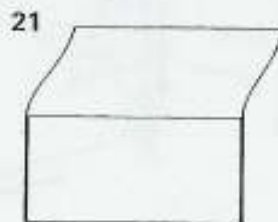
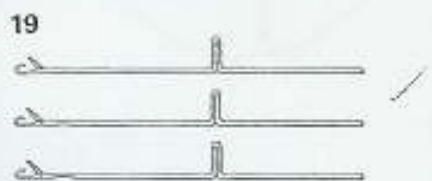
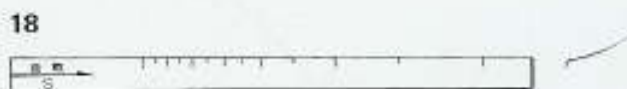
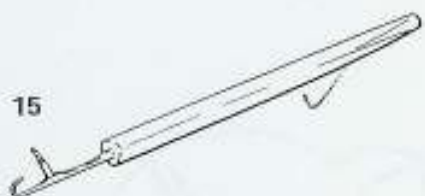
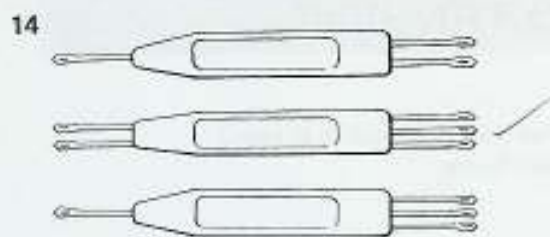

- 14 Transfer Tool (3)
- 15 Tappet Tool
- 16 Crochet Hook
- 17 Tapestry Needle
- 18 Gauge Scale
- 19 Spare Needle (3)
- 20 Ravel Cord (3)
- 21 Card Cleaner
- 22 Cleaning Brush
- 23 Sensor Cleaner
- 24 Oil
- 25 Knit Contour (Radar) Feeding Cam.
- 26 Carriage Fastener

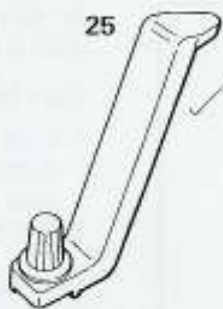

THREADING THE AUTO-TENSION

IMPORTANT:

Before threading the yarn, set the Card Stand referring to page 20. (Leave the Card Stand in position at all times.)
Following the numbers given in the diagram below, guide the yarn through the Auto-Tension.
Place the end in the Yarn Clip on the Yarn Rod.

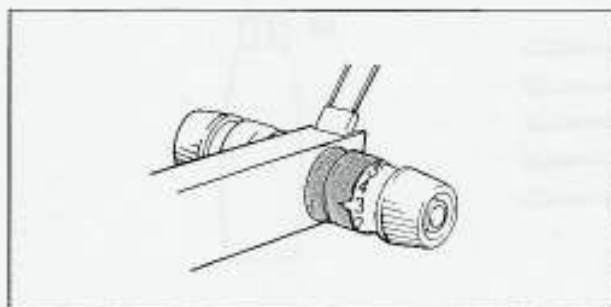
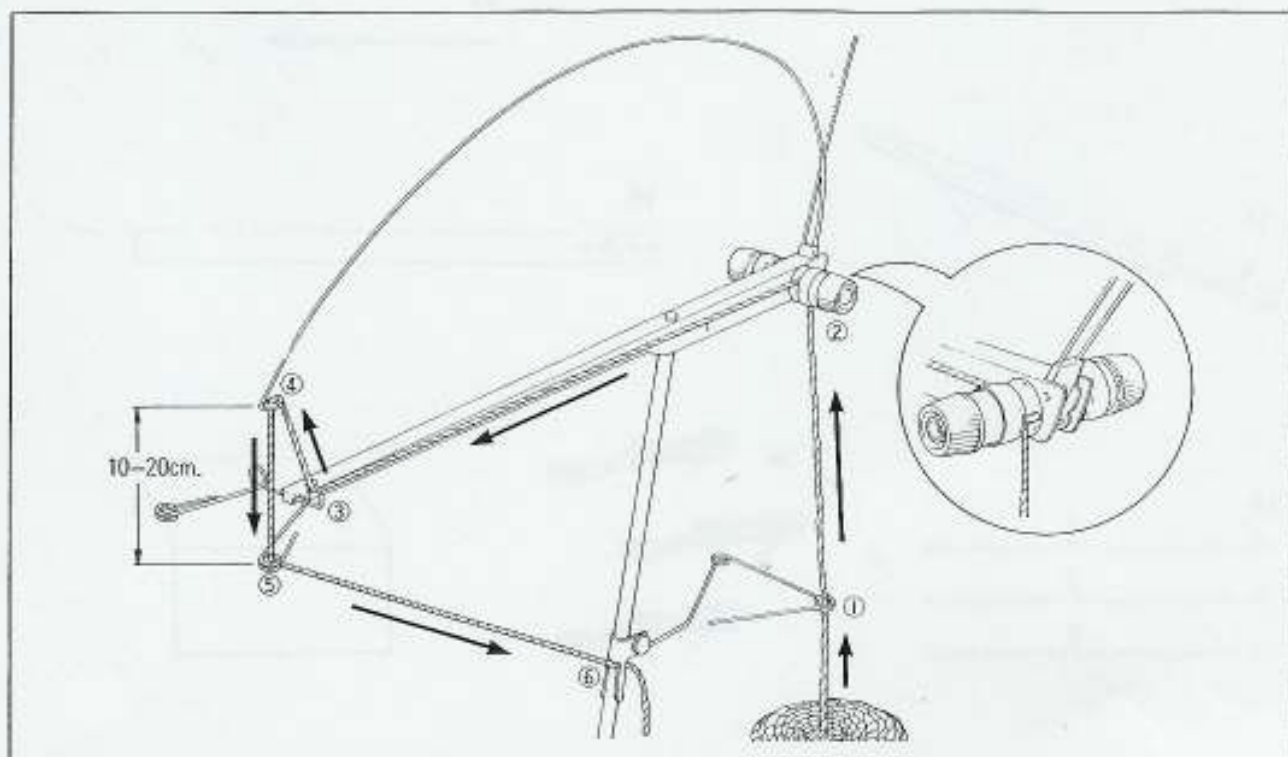

Adjusting the Tension Dial

According to the thickness of the yarn, select a suitable number and set it to the notch.

Recommended Tension Dial setting:—

Cotton or nylon thread.....	6 — 7
Thin yarn (2-ply).....	4 — 5
Medium yarn (4-ply).....	3
Thick yarn.....	1 — 2

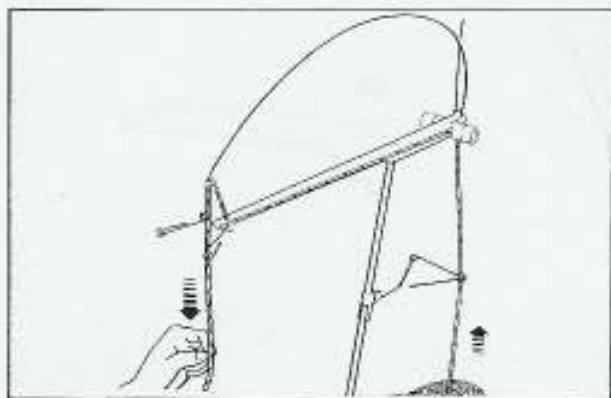

Incorrect threading of the yarn through the Auto-Tension will result in faulty knitting.

Check following two points.

1. Correct tension is given to the yarn.
(Check the distance between the tension spring and the yarn guide — 10—20cm. must be maintained.)
2. Yarn comes out freely from the yarn ball.

It is advisable to pull out a certain length of the yarn from the yarn ball before casting on.

NEEDLE AND NEEDLE POSITIONS

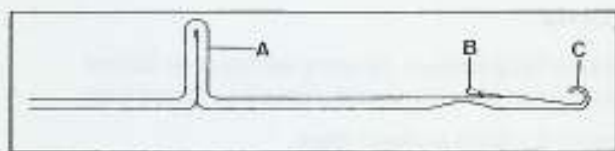

Needle

- A — butt
- B — latch
- C — hook

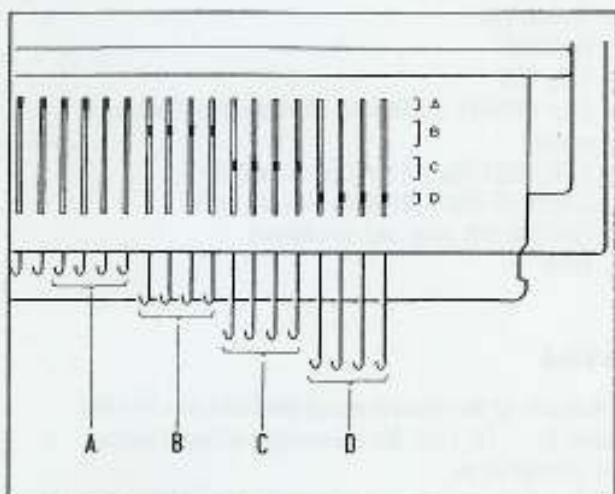

NEEDLE POSITIONS

On both left and right ends of the Needle Bed, the letters A, B, C and D associated with the corresponding brackets "J" are engraved.

To operate the needles, align their butts within the brackets.

- A — needles do not knit.
- B — needles knit stockinet and stitch pattern.
- C — needles knit stockinet only.
- D — needles do not knit with Russel Levers at **I**; needles are knitted back to B position with Russel Levers at **II**.

NOTE: NEEDLE POSITIONS C AND D ARE NOT TO BE USED WHEN KNITTING WITH THE LACE CARRIAGE.

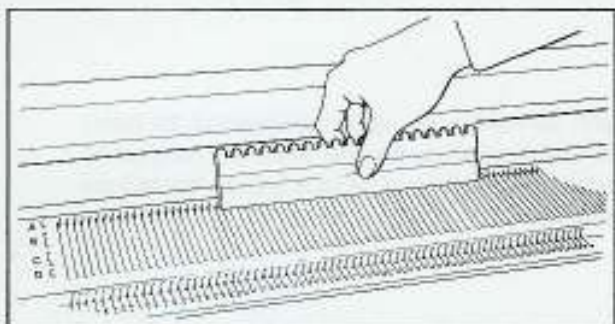

Using the straight edge of the Needle Pusher, align the needles correctly in A position.

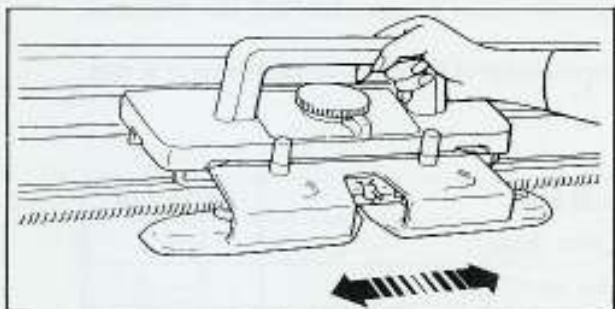

Slide the Carriage across the Needle Bed a few times to ensure it moves smoothly.

If the Arm is attached incorrectly, it will rub against the Sinker Posts.

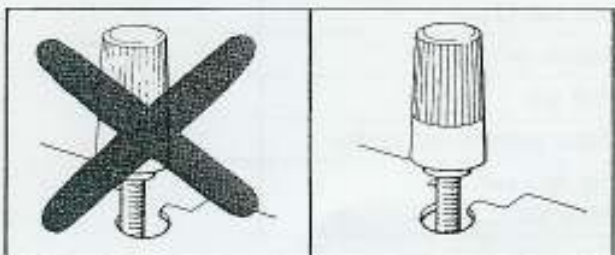

The Arm must be secured by the Arm Nut as illustrated.

CAM LEVER AND STITCH DIAL

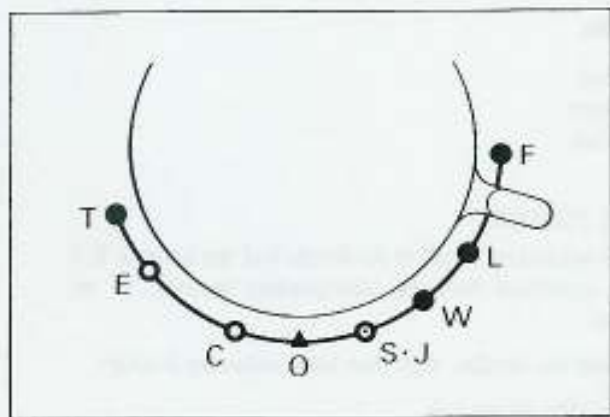

Cam Lever

The Cam Lever has 8 positions. By setting the Cam Lever different types of stitch pattern can be knitted when using a Pattern Card.

Each position is marked as shown below.

- F..... FAIR ISLE (KNIT-IN)
- L..... PUNCH LACE
- W..... WEAVING
- S.J..... S for SLIP
J for DOUBLE JACQUARD when the Yarn Changer is in use.
- O..... STOCKINET (No pattern Card is needed.)
- C..... CIRCULAR KNITTING (only with the Ribber.)
- E..... ENGLISH RIB (only with the Ribber)
- T..... TUCK

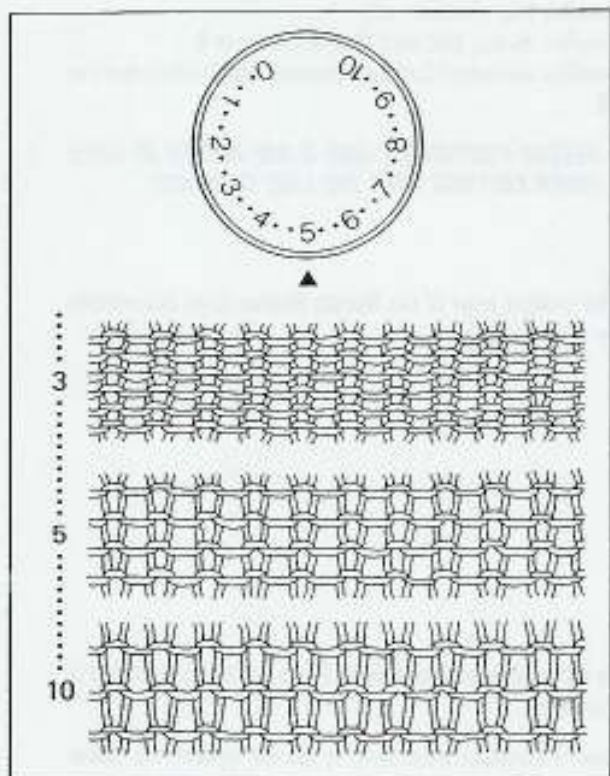

Stitch Dial

The Stitch Dial is on the same section as the Cam Lever. The dial is numbered 0 — 10. Each dot represents a different tension, giving 31 settings in all.

The Stitch Dial is used to adjust the tension of knitted fabric as it regulates the size of stitch for a given type of yarn.

The smaller the number, the tighter the tension of the knitted fabric because the stitch size becomes smaller and the larger the number the looser the tension of the fabric because the stitch size becomes larger.

The photograph below shows various types of yarn actual size, and in the table below, recommended Stitch Dial settings are given.

The selected number of the Stitch Dial must be set at ▲ mark.

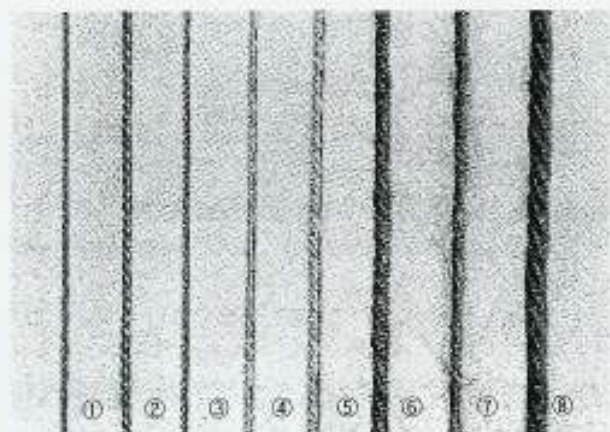

Type of yarn	Stitch Dial
① Cotton thread	2 — 3
② Thin yarn (2-ply)	2 — 3
③ Summer yarn	3 — 4
④ Light yarn (3-ply)	3 — 5
⑤ Medium yarn (4-ply)	4 — 6
⑥ Thick yarn	6 — 9
⑦ Mohair (every second needle)	8 — 10
⑧ Very thick yarn (every second needle)	6 — 9

CAST-ON AND STOCKINET KNITTING

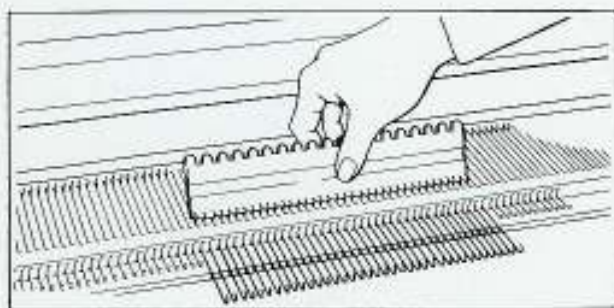

Using the Needle Pusher, align the needles in D position as shown.

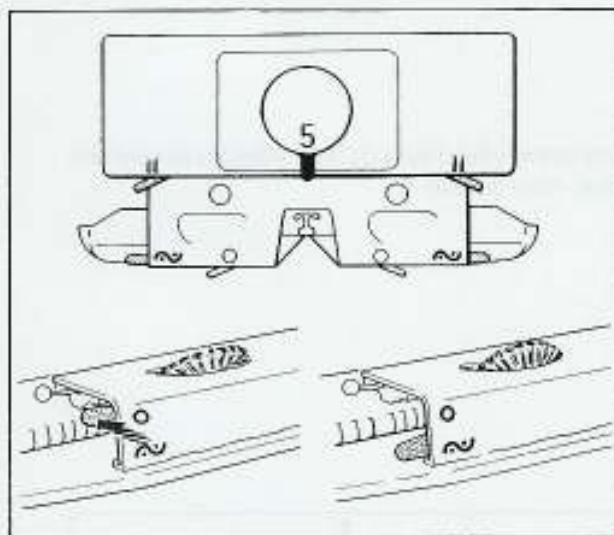

Set the Carriage as follows:

Cam Lever.....	0	(STOCKINET)
Stitch Dial.....	5	
Russel Lever.....	II	(both)
Weaving Knob*.....	~	(both)
Tuck Lever.....	O	(both)

*To set the Weaving Knob to ~ mark, push it slightly forward, then it drops down.

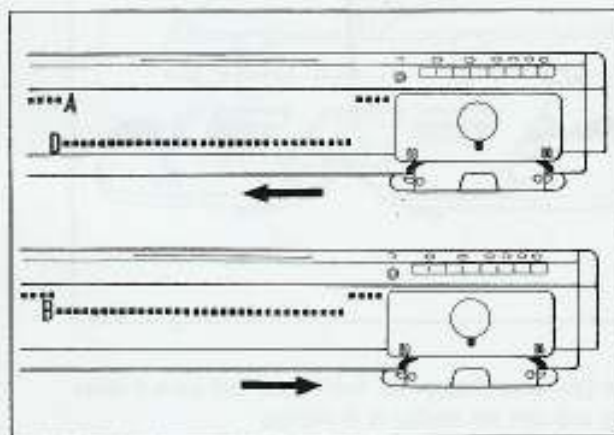

Slowly move the Carriage across the needles, and the needles will align in B position.

Leave the Carriage at the right side.

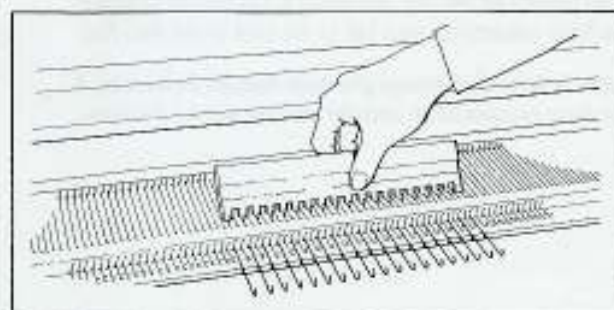

Using the Needle Pusher, push every 2nd needle from B to D position.

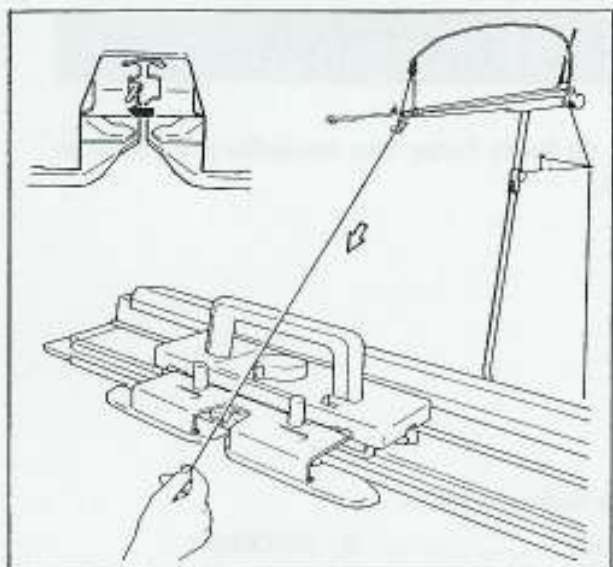

Open the Yarn Feeder Gate, and take the yarn from the Yarn Clip, and pull it down to the Yarn Feeder.

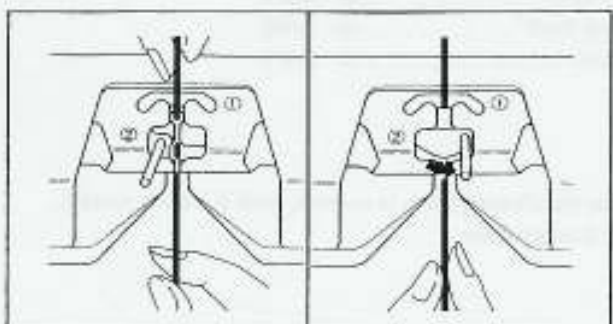

Guide the yarn into Yarn Feeder ①, and holding the yarn end with your hand, close the Gate.

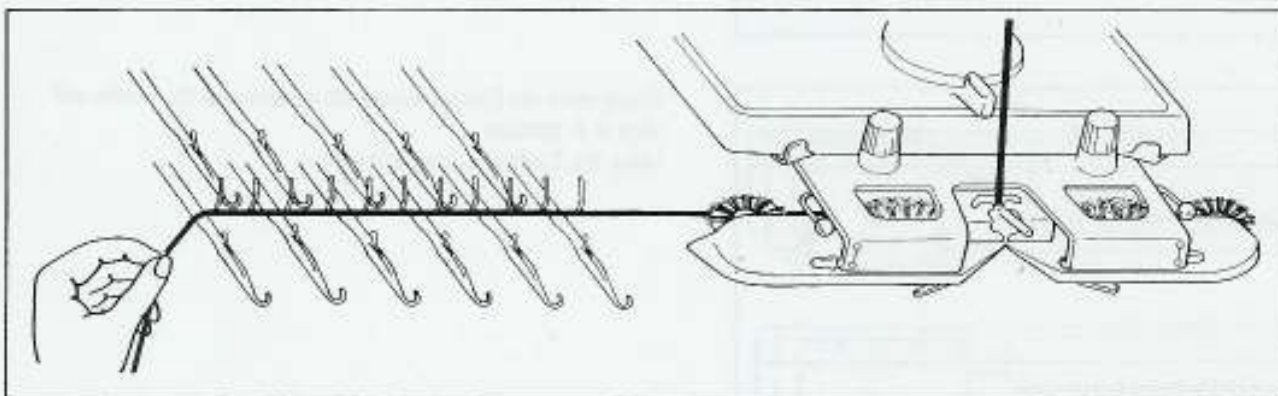

Pull the yarn down through the Yarn Feeder, and guide it under the Arm and over the needles in D position.

Check the tension on the yarn, and adjust it if necessary by pulling the yarn back towards the yarn ball at the back of the Yarn Rod.

If the yarn is threaded through the Auto-Tension incorrectly, it will not have tension on it, and the cast-on will be a failure.

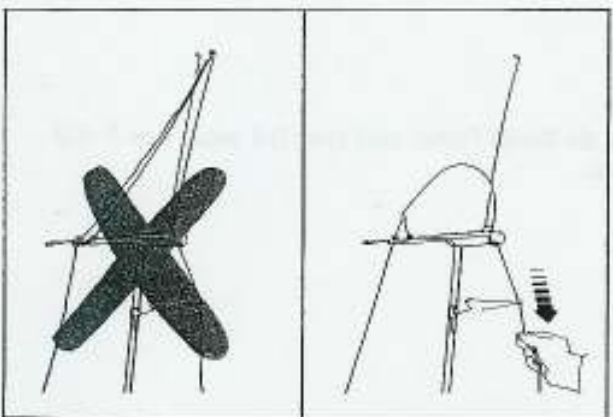

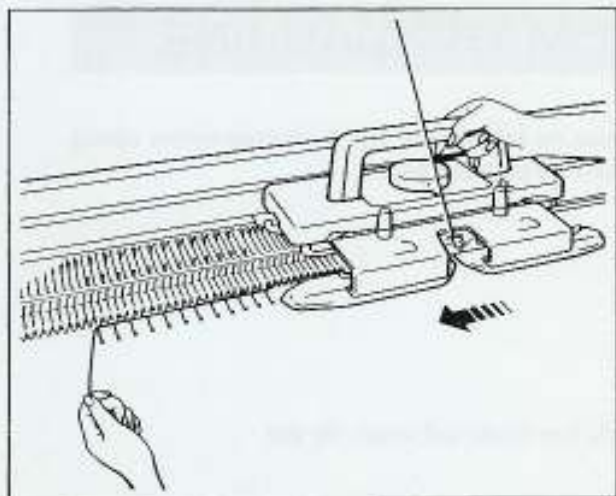

Hold the yarn at the left side of the needles, and make sure that the latches of the needles in D position are open.

Hold the yarn end approximately 40cm, below the last needle at the left.

Move the Carriage slowly over the needles to the left side.

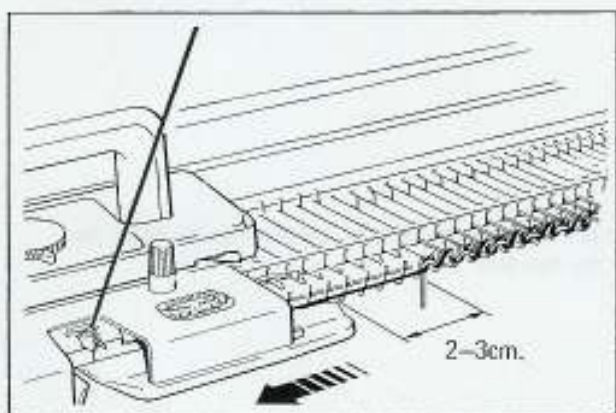

Ensure that the Arm has passed the last knitting needle by approximately 2—3cm.

Knit 4—5 rows more in the same manner.

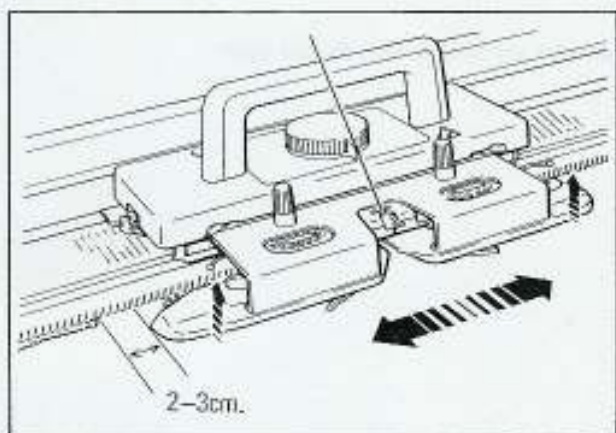

Set the Weaving Knobs back to O.

Move the Carriage back and forth to knit stockinet.

Move the Carriage at an even speed.

On each row, ensure that the Arm has passed the last knitting needle by approximately 2—3cm.

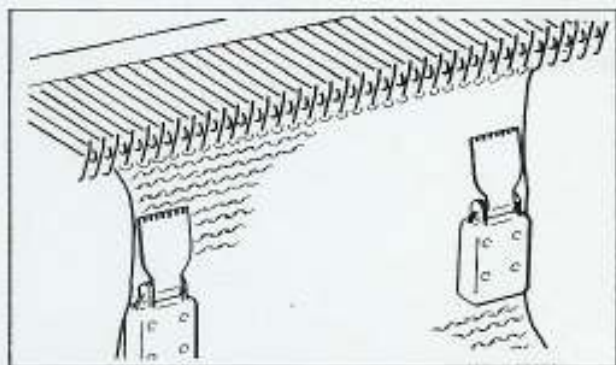

Take out the Claw Weights from the Accessory Box, and hang them on the fabric as shown, and continue to knit moving the Weights up every 30—40 rows.

REMOVING THE FABRIC FROM THE MACHINE



To remove the knitted fabric from the machine without casting off, follow the procedure below.

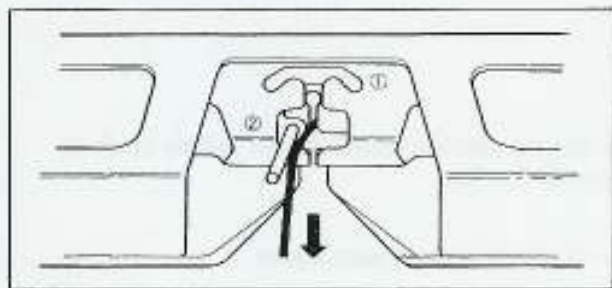

Open the Yarn Feeder and remove the yarn.

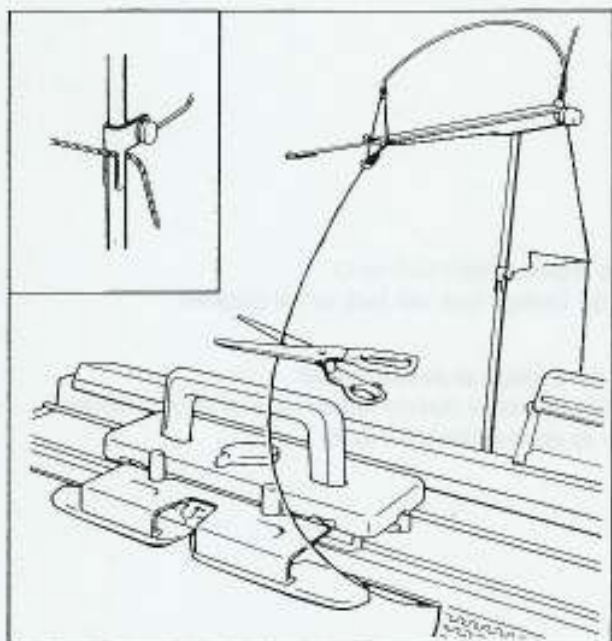

Cut the yarn above the Yarn Feeder, and place the top end in the clip on the Yarn Rod.

Leave the yarn end hanging from the last stitch.

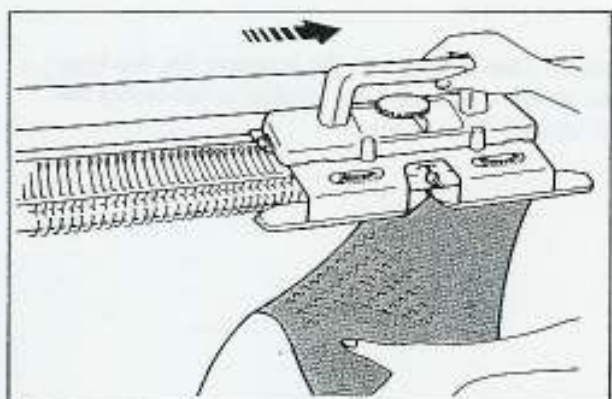

Set the Cam Lever to "0" (STOCKINET) and move the Carnage across the fabric.

The fabric will come off the needles.

PATTERN CARD

PATTERN CARD is printed with rectangles. Each rectangle is proportional to the size of a stitch. The black area represents a pattern to be produced on a knitted fabric.

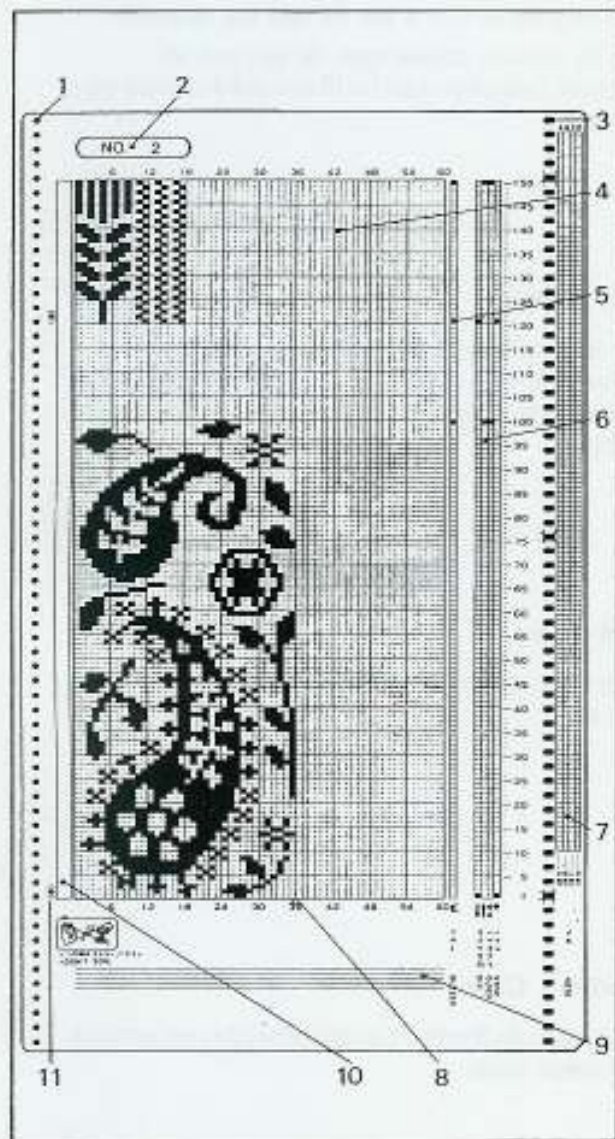

- 1 Feeding hole (left)
- 2 Card Number
- 3 Feeding hole (right)
- 4 Pattern area
A pattern of 150 rows and 60 stitches can be drawn in this area.
- 5 Buzzer column
The mark in this column operates the buzzer when the marked row is read.
- 6 Instruction columns (used to control the movement of Pattern Card.)

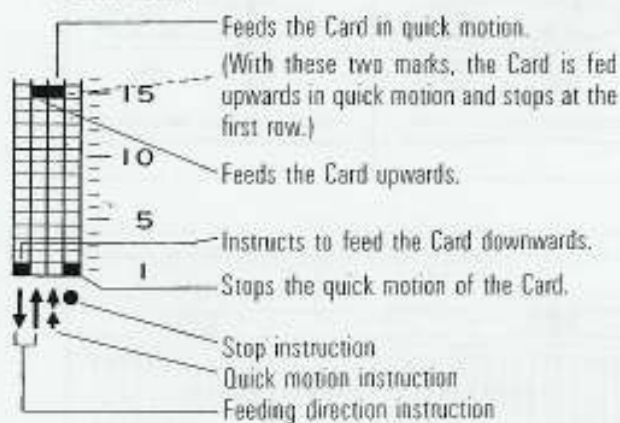

- 7 Notation column
Use this column to note the row to change yarn or other indication. (As there is a 10-row difference between the row to knit and the row visible above the Card Slot, be sure to mark the tenth row above the actual row to be knitted.)
- 8 Pattern width setting mark
The triangle shows where the pattern width indicator can be set to vary the pattern. Set the Pattern Width Indicator correspond with the triangle mark.
- 9 The horizontal lines are provided as a guide to ensure that the card is correctly inserted.
- 10 Do not soil this column.
- 11 Pattern number

DESIGN CARD (5 sheets)

The Card is made of semi-transparent paper and has same rectangles as the Pattern Card. A pattern of your choice can be drawn on the Card using the Design Pencil. Refer to page 111.

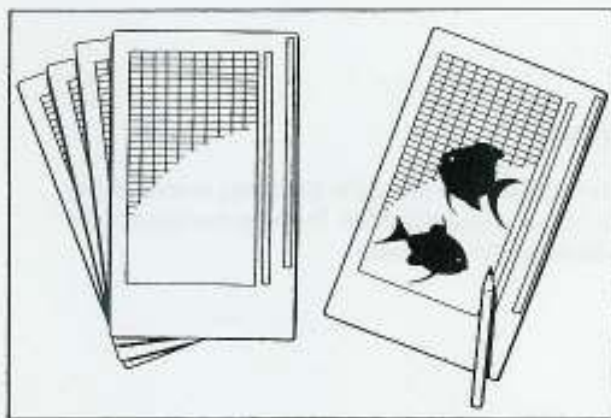

PATTERN CONTROLS

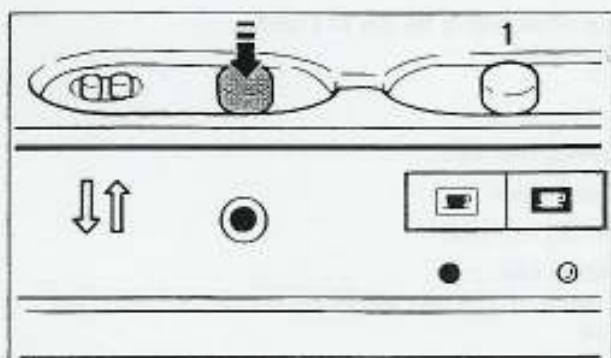

Inspection Button

When the Button is pressed down the light is turned on. The Pattern Card moves up by 10 rows and stops. This setting can be used to knit the same row repeatedly. When the Button is pressed again, the light goes off. The Pattern Card will go down for 10 rows and the pattern rows memorized.

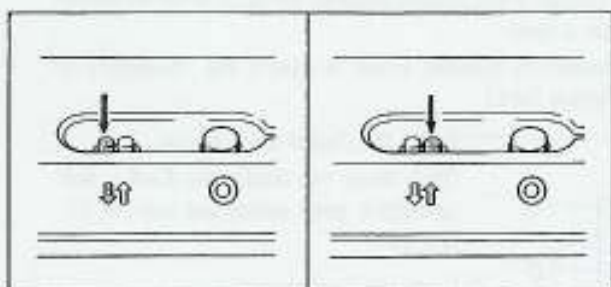

Card Buttons

There are located at the left of the Inspection Button. When either of these two buttons are pressed down, arrow mark below will be lit, and the Pattern Card will move in the direction indicated.

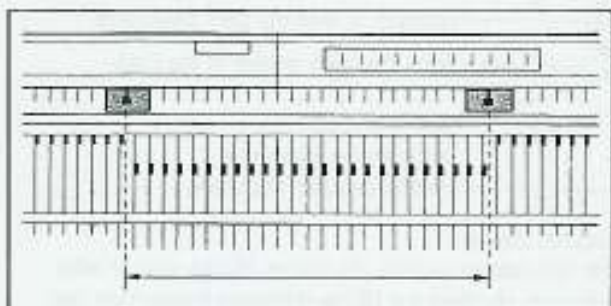

Point Cam

Pattern knitting always takes place on the needles between two point cams.

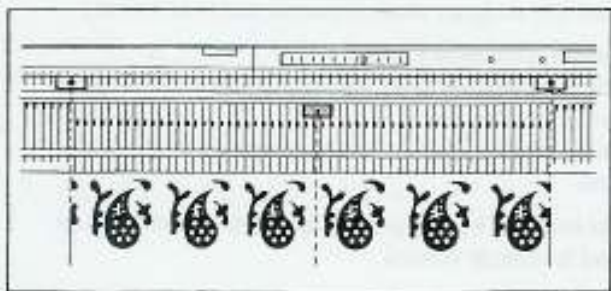

Needle-1 Cam

The red line on the Needle-1 Cam determines the start and finish of the pattern repeat.

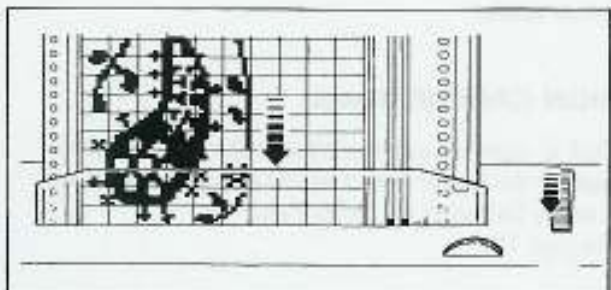

Card Dial

Turn the Card Dial to set the card to the starting position, and to remove the card from the Card Slot. The inspection light must be "ON" whenever this dial is used.

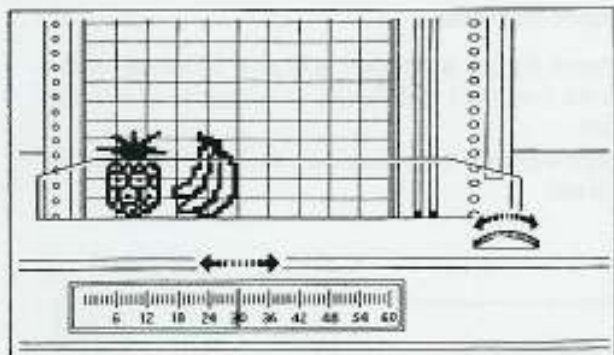

Pattern Width Indicator

The pointer of the Pattern Width Indicator is set by turning the Pattern Dial, and will select part, or all of the pattern.



PATTERN WIDTH SETTING

The area of the Pattern Card at the left side of the Pointer shows the width the pattern to be knitted.

Samples below show patterns using various settings of the Pattern Width Indicator.

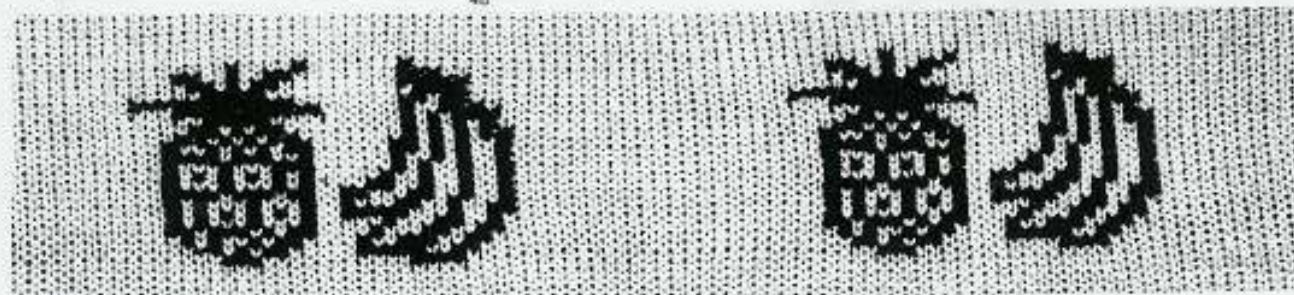
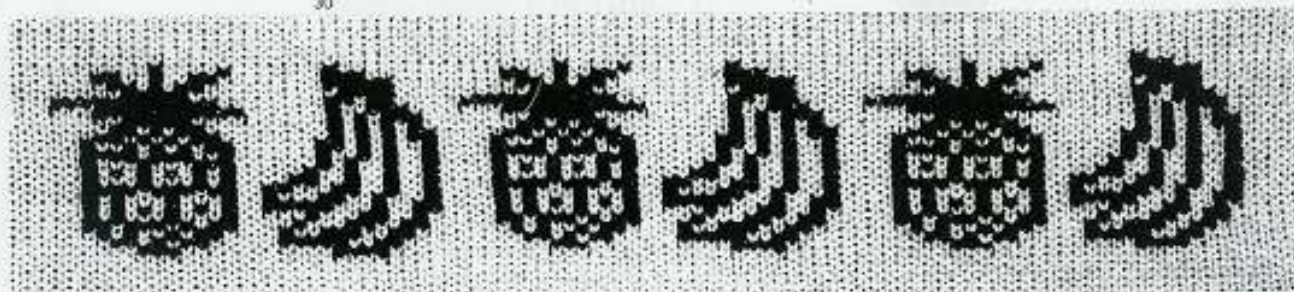
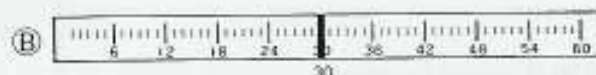
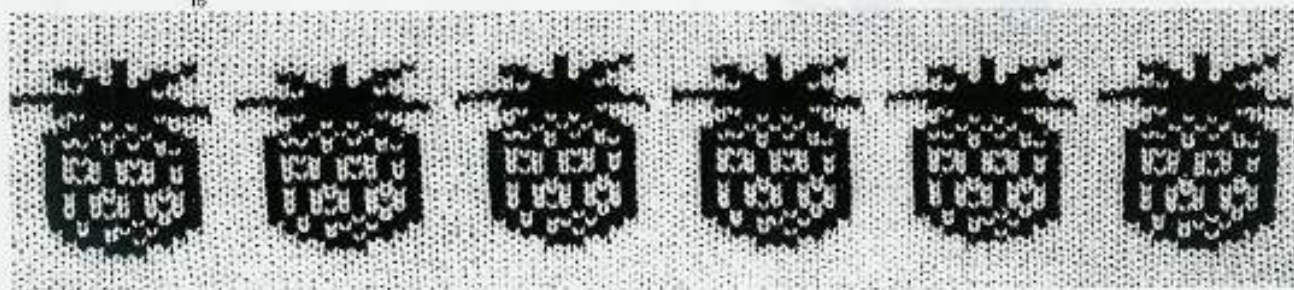

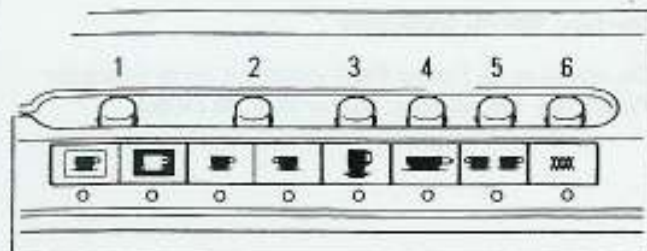

Pattern Buttons

Six Pattern Buttons, numbered 1 to 6, with "coffee cup" marks show the function of each Button, to indicate the state of the Buttons.

The light below the button indicates whether the function is in use or not.

		<p>BUTTON 1 (Colour Normal/Reverse)</p> <p>Colour Normal: (left light on) Yarn in Yarn Feeder ① knits the ground colour. Yarn in Yarn Feeder ② knits the contrast colour.</p> <p>Colour Reverse: (right light on) Colour of ground and contrast yarns are exchanged.</p>
		<p>BUTTON 2 (Direction Normal/Reverse)</p> <p>Direction Normal: (left light on) The pattern is reproduced on the plain side of the fabric, exactly as it appears on the Card.</p> <p>Direction Reverse: (right light on) The Pattern is reproduced on the plain side of the fabric, in the opposite direction from the card.</p>
		<p>BUTTON 3 (Vertical Expansion)</p> <p>Expands the pattern on the Card twice its normal size vertically.</p>
		<p>BUTTON 4 (Horizontal Expansion)</p> <p>Expands the pattern on the Card twice its normal size horizontally.</p>
		<p>BUTTON 5 (Mirror Image)</p> <p>The pattern is reproduced on the fabric as if it were reflected in the mirror.</p>
		<p>BUTTON 6</p> <p>This Button is used only when knitting double jacquard with the use of the Automatic Yarn Changer. (Refer to page 92.)</p>

PREPARATION FOR PATTERN KNITTING

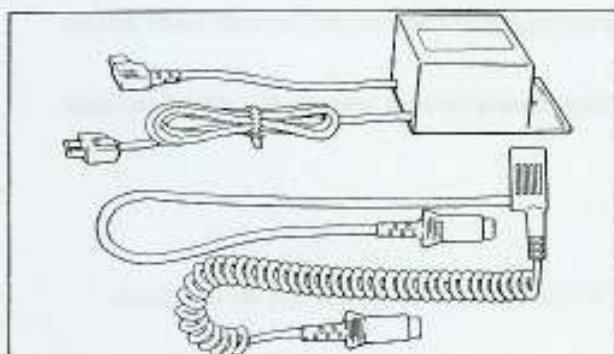

A micro-computer is incorporated in the machine and takes on full control of needle selection for pattern knitting.

SETTING UP THE MACHINE FOR PATTERN KNITTING

- ① Take off the Auto-Tension from the top of the Yarn Rod. Fit the Curl Cord Support Block on top of the Yarn Rod, and bring it down till it stops. Set the Auto-Tension on the Yarn Rod again.
- ② Connect the plug at the end of the straight cord to the socket on the machine so the triangle marks correspond.
- ③ Connect the plug at the end of the Curl Cord to the socket on the Carriage so the triangle marks correspond.
- ④ Connect the plug on the Power Cord to an A.C. mains supply.
- ⑤ Connect the inlet cord from the Transformer to the machine.

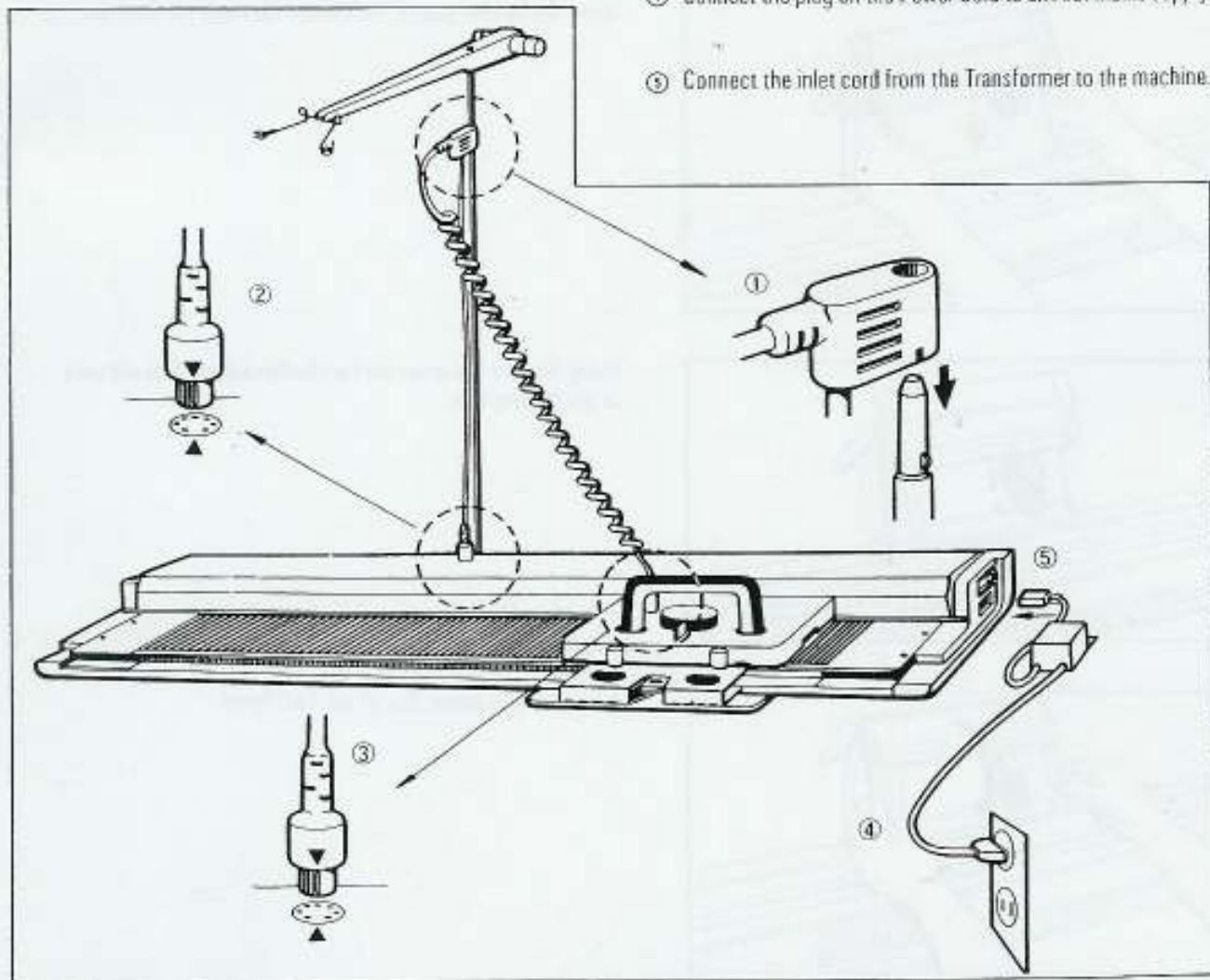
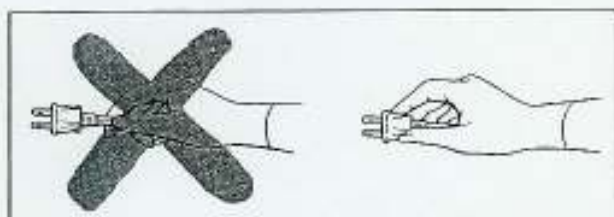

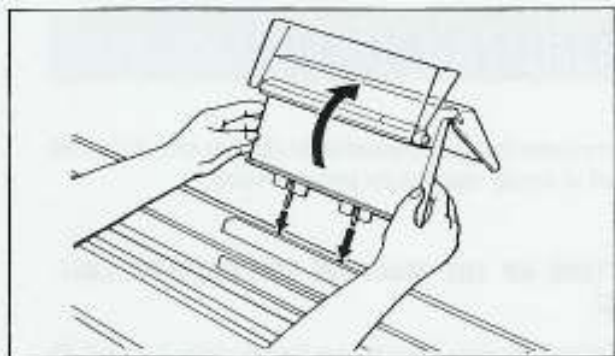

SETTING THE CARD STAND AND PATTERN CARD

Hold the Card Stand with the transparent flap facing you, and lift the flap as shown.

Fit the two pegs of the Card Stand into two holes behind the Card Slot.

If a Pattern Card is not used, lower the flap of the Card Stand.

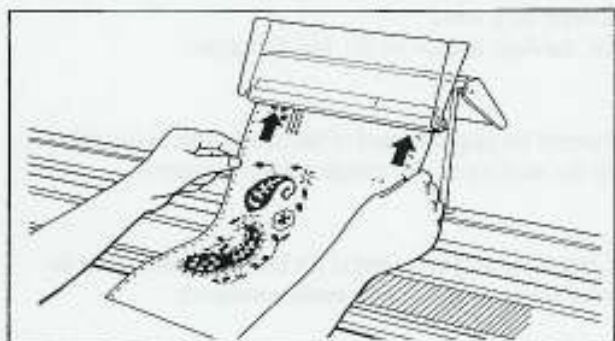

Insert the top end of a Pattern Card into the Card Stand.



Insert the bottom end of the Pattern Card into the Card Slot.

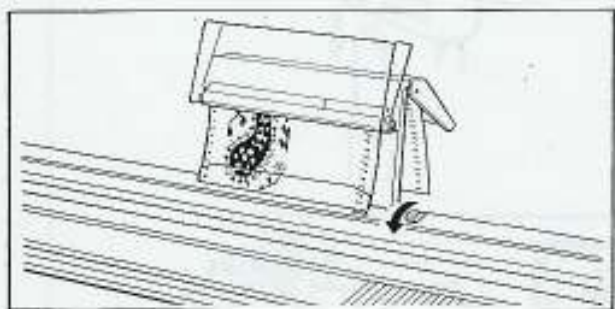

Using the Card Dial insert the Card further into the Slot and set it to the starting line.

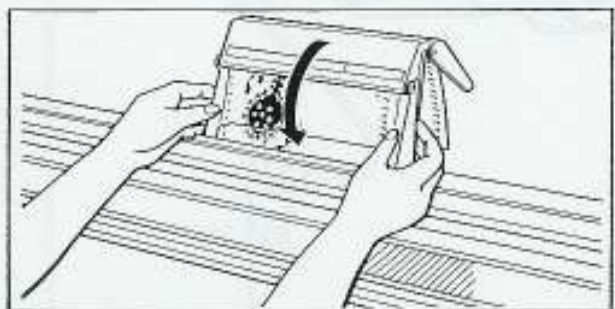

Lower the transparent flap of the Card Stand.

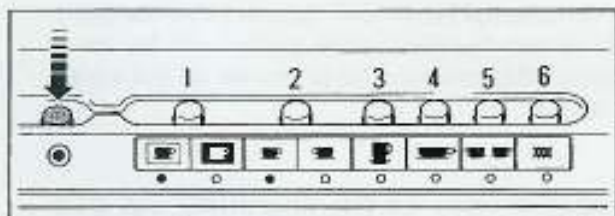

SETTING THE PATTERN CONTROLS

Switch ON the machine. (Press the **■** side of the ON-OFF Switch.)

The Buzzer sounds once, and either of the two lights on Buttons 1 and 2 are on.

Push the Inspection Button on. (Light is on.)

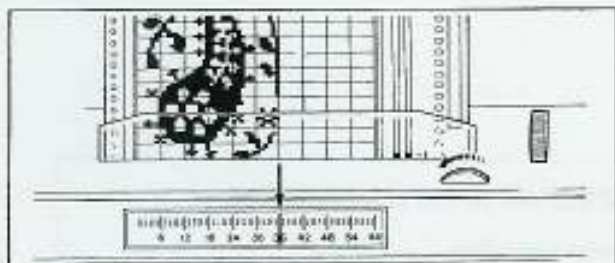

As instructed at the bottom of each photograph in the Pattern Book, select the Pattern Buttons and set the pattern width by turning the Pattern Dial.

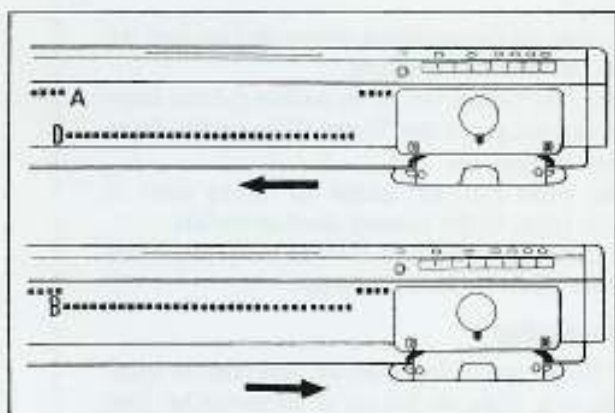

Push the required number of needles into D position.
Set the Carriage as below.

Cam Lever..... 0 (STOCKINET)

Russel Levers..... II

Move the Carriage across the needles to align them in B position. (In case knitting has already been started, this step can be skipped.)

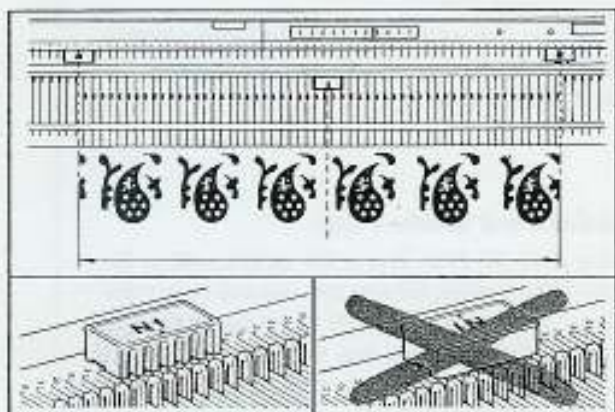

Set the Point Cams at both ends of the needles in B position so their red marks come to the outside of the end needles.

Set the Needle-1 Cam at any position desired between the Point Cams.

Set the Needle-1 Cam into the holes at the back of the needle bed.

The Needle-1 Cam must be placed behind the needles, with the red line facing you.

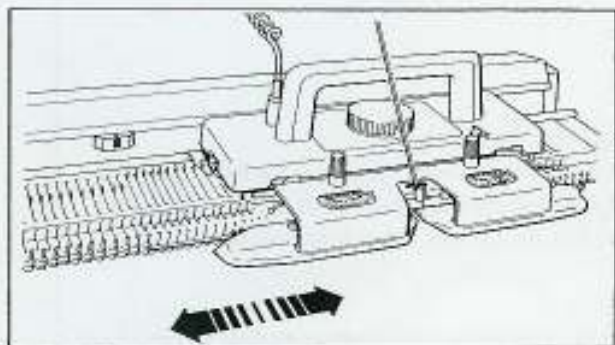

Thread yarn through the Auto-Tension and into the Yarn Feeder **①**.

Cast-on and knit several rows in stockinet, finishing with the Carriage at the right (Refer to page 11.)

If there is already knitting on the needles, move the Carriage across twice without knitting, by using the Release Lever.

This is to enable the machine to memorize the settings of the Point Cams, the Needle-1 Cam.

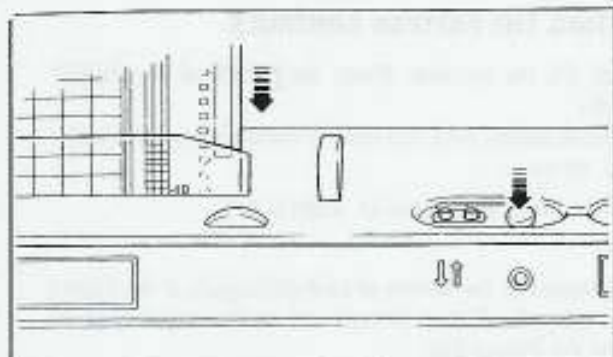

Push the Inspection Button "OFF". (Light is off and the Card is fed by 10 rows downwards and the pattern on the first row is memorized. While memorizing the pattern, you will hear a scanning sound.)

PREPARATORY STEPS FOR PATTERN KNITTING HAVE BEEN COMPLETED.

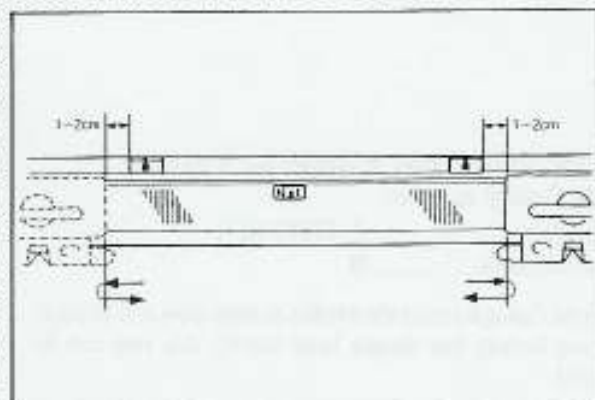

PRECAUTION IN PATTERN KNITTING

Carriage operation

Move the Carriage until it clears both Point Cams before returning it.

If you return the Carriage before clearing the Point Cam, the pattern will be knitted incorrectly.

To correct the memory, turn off the machine and then follow the instructions given under "To turn off the machine during knitting" on page 101.

Knitting speed must not exceed the reading speed of patterns. Listen for the scanning sound as you knit.

If the Carriage is moved back and forth too quickly, it may cause the reader to skip a pattern row.

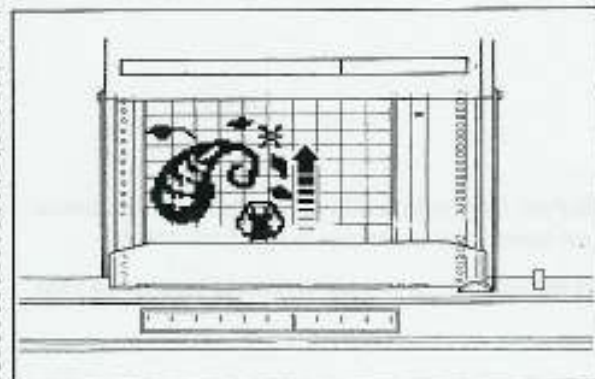

Card returning

When the last row of the pattern has been read, the buzzer sounds once. When the last row of the pattern has been knitted, the Pattern Card returns to the first row of the pattern in a quick motion.

While the Card is in quick motion hold the Carriage outside the Point Cams till the Card stops, and memorizing the pattern is completed.

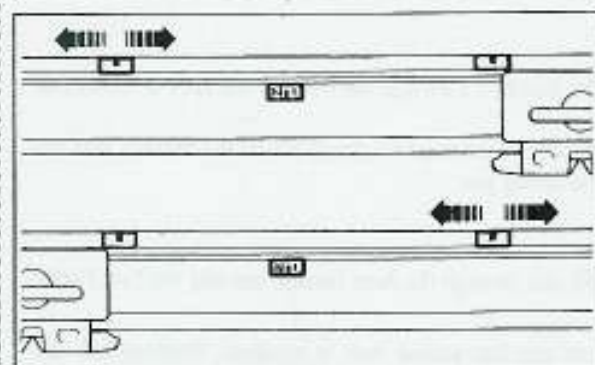

Point Cams and Needle-1 Cam

You may move the Point Cam at the opposite side to the Carriage before knitting the next row, you may never move the Point Cam at the Carriage side during pattern knitting. (If the Point Cams are away from the edge of the knitted piece as a result of decreasing, make sure the Carriage passes the Point Cams.)

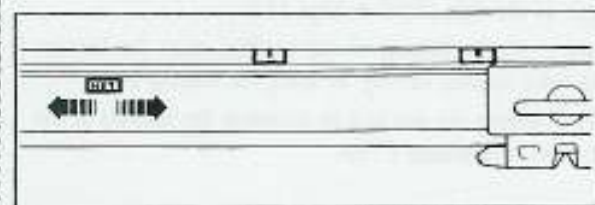

Do not move the Needle-1 Cam.

If the Needle-1 Cam is left outside of the Point Cam as a result of garment shaping, leave it in its original position, but ensure that the Carriage passes it on each row.

FAIR ISLE (KNIT-IN)

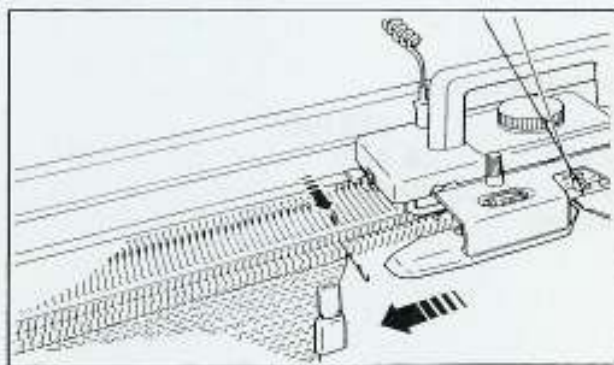
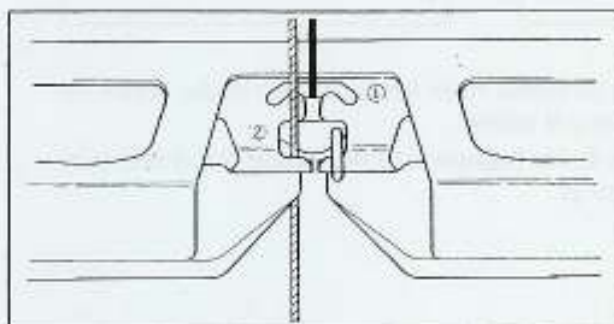
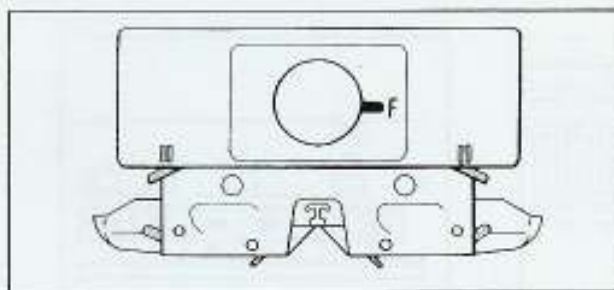
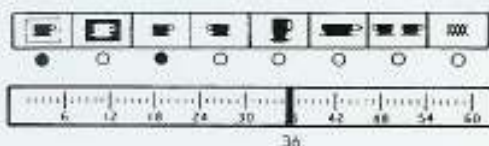
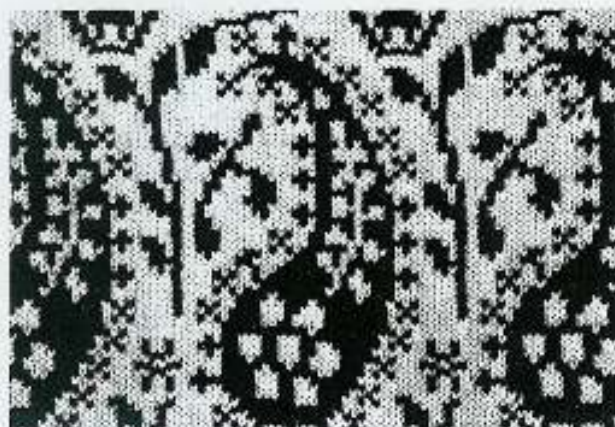

Two yarns of different colours are knitted simultaneously and form patterns on the fabric.

The sample is knitted with the Pattern No.2—(8).

Before starting to knit the patterns, follow the preparatory steps given on pages 19—22 and follow instructions given below.

BEFORE KNITTING THE PATTERN

Set the Carriage controls:

Cam Lever..... F (FAIR ISLE)
 Russel Lever..... II (both)
 Tuck Lever..... O (both)
 Weaving Knob..... O (both)

Thread the contrast yarn through the Auto-Tension and into Yarn Feeder ② as shown opposite.

WHILE KNITTING THE PATTERN

To make both edges of the fabric neat, push up the first needle to D (or C in partial knitting) position before knitting the next row.

Suspend the Claw Weights at both sides of the fabric.

SINGLE MOTIF

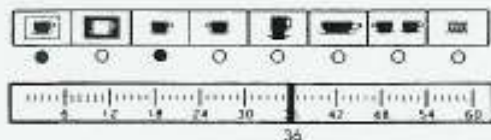

A single pattern in Fair Isle (Knit-in) can be knitted at any position on the fabric.

The sample is knitted with the Pattern No.5—(14).

Before knitting patterns in this stitch type, follow the Preparatory Steps given on pages 19—22, and instructions below.

BEFORE KNITTING THE PATTERN

The sample shown here has a pattern width of 36 stitches. Set the Point Cams 36 needles apart, and align the red line of the Needle-1 Cam with the red line of the left Point Cam, as shown in the diagram.

When knitting in single motif pattern, the Button 1 must have the left light on.

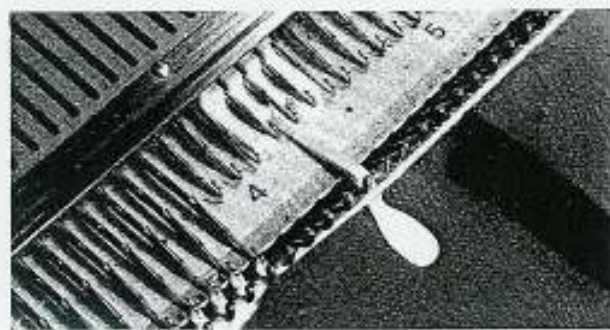
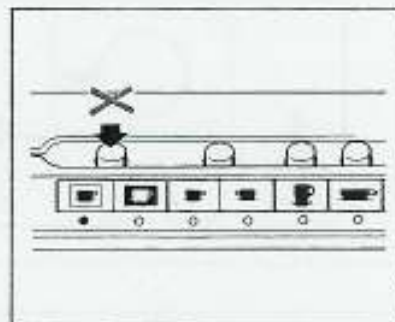
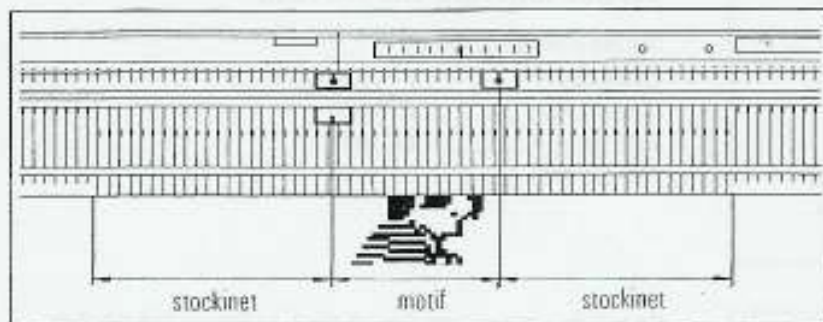

Open the latches of the 4th, 5th and 6th needles beyond the needles in B position.

Insert the Yarn Separator under those needles on both sides as far as they go.

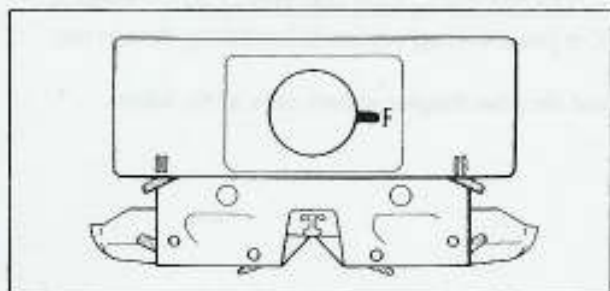

Set the Carriage controls:

Cam Lever..... F (FAIR ISLE)
 Russel Lever..... II (both)
 Tuck Lever..... O (both)
 Weaving Knob..... O (both)

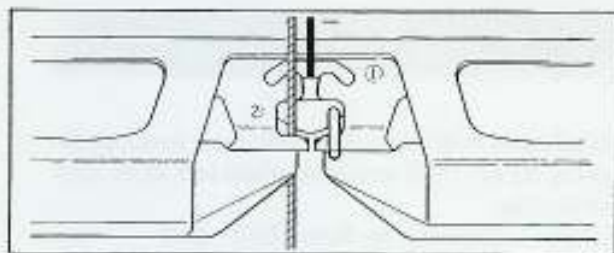

Put the contrast yarn into the Yarn Feeder ②, and start knitting.

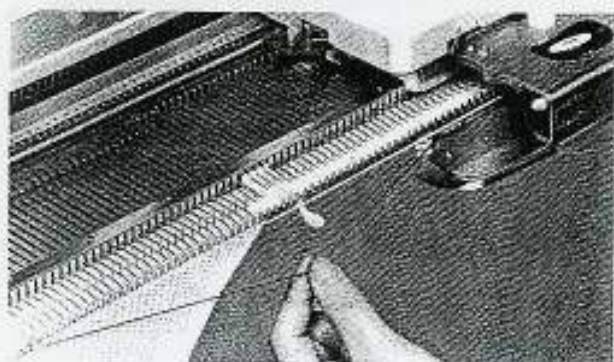

WHILE KNITTING THE PATTERN

Make sure that the main yarn comes above the Separator and the contrast yarn below the Separator before knitting the next row. If they are not, correct them manually.

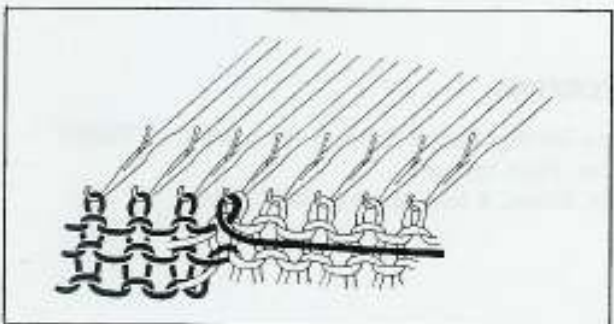

To prevent separation of ground yarn from the contrast yarn at the edge of pattern, wind the contrast yarn around the needle adjacent to the edge needle of the contrast yarn. (To wind the yarn, push the needle to C position, the stitch must remain in front of the latch, and wind the yarn around the needle. Return the needle to B position.)



During knitting, make sure the Carriage clears the Separator by 2 — 3cms.

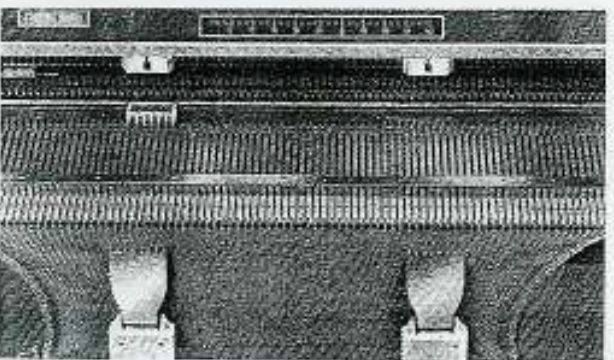

Hang the Claw Weights on the fabric at the position corresponding to the edge of the single motif pattern.

TUCK STITCH

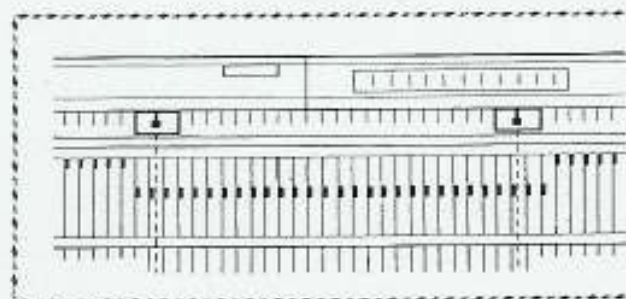
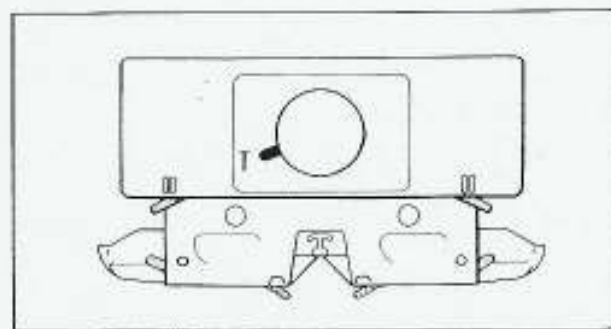
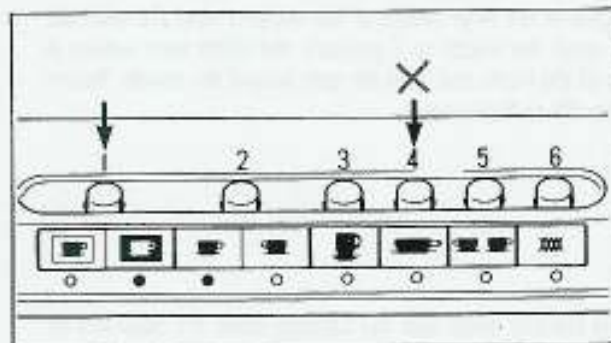
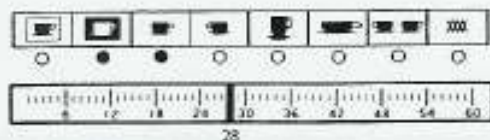

A selected needle holds yarn in the hook for one or more rows. On completing the tuck stitch section, the needle knits all the loops of yarn together.

The sample is knitted with the Pattern No.6—(17).

Before knitting this stitch pattern, follow the Preparatory Steps given on pages 19—22, and instructions given below.

PRECAUTION

In tuck knitting, Pattern Button 1 must remain in "DOWN" position. (Right light on.)

Pattern Buttons 4 must remain in "OFF" position.

BEFORE KNITTING THE PATTERN

Set the Carriage controls:

Cam Lever.....T (TUCK)
 Russel Lever.....II (both)
 Tuck Lever.....∩ (both)
 Weaving Knob.....O (both)

If the edge stitches knit incorrectly, set the Point Cams to exclude two edge needles on both sides, from the pattern knitting area.

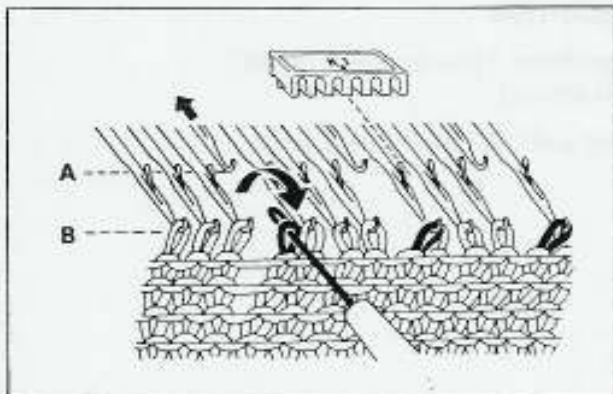
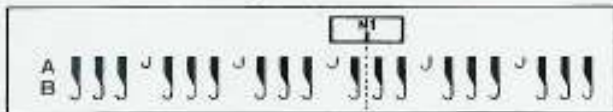
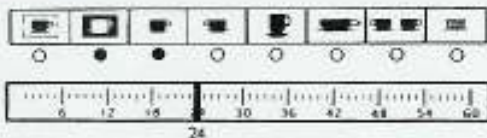
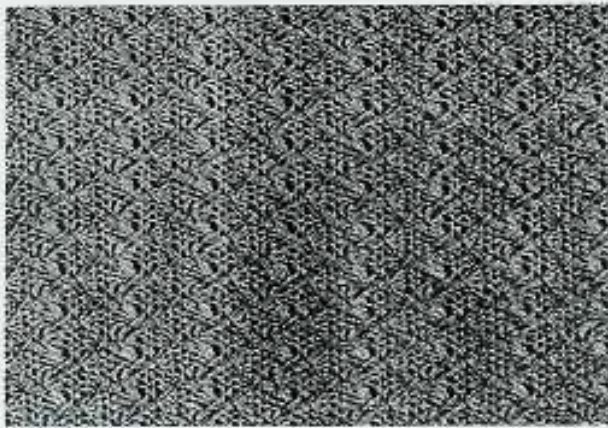

TUCK LACE

Arrange the needles as instructed below and knit as for Tuck Stitch.

The sample is knitted with the Pattern No.1—(3).

Before knitting this stitch pattern, follow the Preparatory Steps given on pages 19—22, instructions given below.

BEFORE KNITTING THE PATTERN

Rearrange the needles as illustrated, by transferring the stitches using a Transfer Tool.

In the Pattern Book, needle arrangement shown for each pattern in Tuck Lace.

Push the empty needles back into A position.

SLIP STITCH

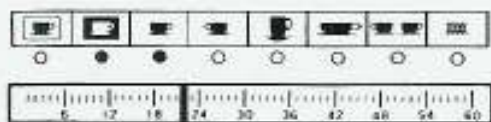
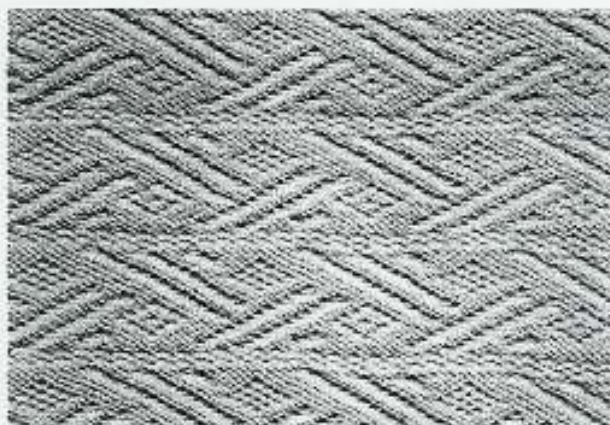

22

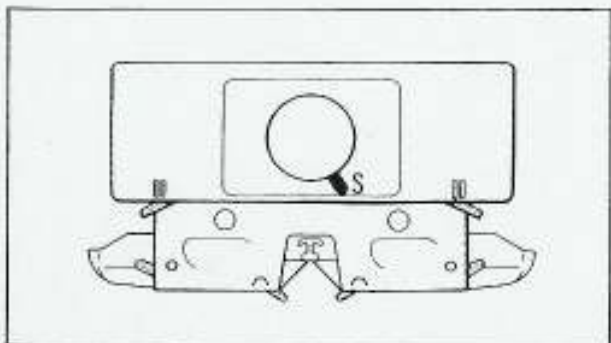
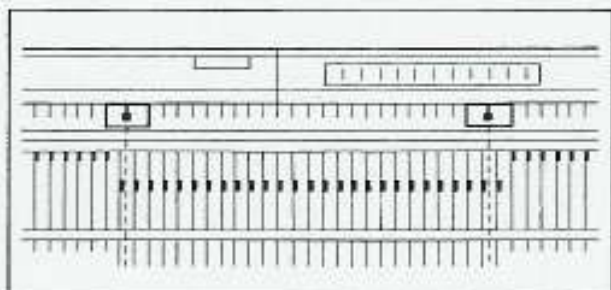
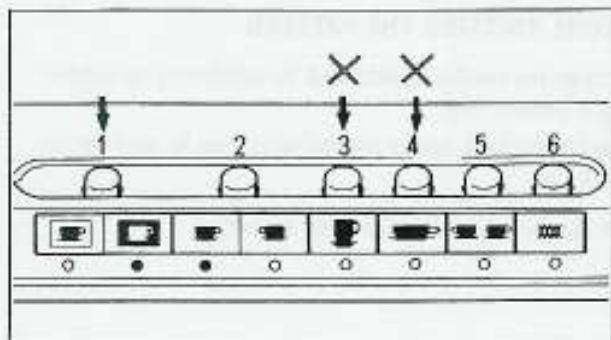

A selected needle remains inactive and the yarn passes in front of the needle. Non-selected needles knit stockinet.

The sample is knitted with the Pattern No.8—(24).

Before knitting this stitch pattern, follow the Preparatory Steps given on pages 19—22, and instructions given below.

PRECAUTION

Pattern Button 1 must be pushed "DOWN".
(Right light on.)

Do not push "ON" the Buttons 3 and 4.

To prevent the end stitches from knitting incorrectly, set the Point Cams to exclude the edge needle from the pattern knitting area.

BEFORE KNITTING THE PATTERN

Set the Carriage controls.

Cam Lever.....S (SLIP)
Russel Lever.....II (both)
Tuck Lever.....O (both)
Weaving Knob.....O (both)

It is recommended to set the Stitch Dial 1 number higher than for other stitch types.

TUCK/SLIP STITCH PATTERN IN COLOURS

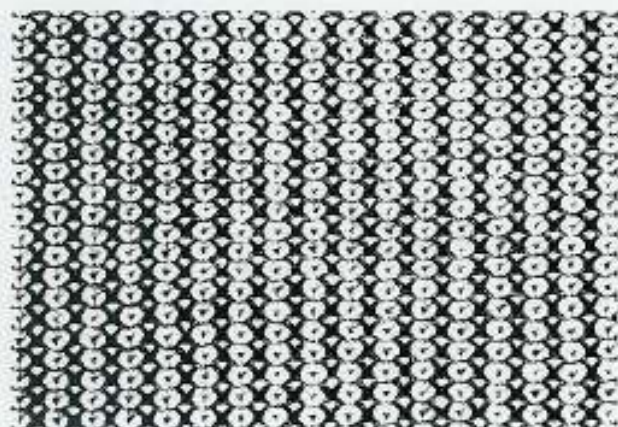

Tuck stitch patterns or slip stitch patterns can be knitted using yarns of different colours.

The Automatic Yarn Changer YCB is available as an accessory, and is very useful for multi-coloured tuck and slip stitch patterns.

The picture on top shows the pattern knitted in TUCK with the Pattern No. 1—(5) and the second picture shows SLIP with the Pattern No. 1—(6).



The picture on top shows the pattern knitted in TUCK with the Pattern No. 1—(5) and the second picture shows SLIP with the Pattern No. 1—(6).

The chart on page 114 shows which cards can be knitted in which stitch patterns. Referring to the chart, use other tuck and slip stitch cards, and change the colours during knitting.

The preparatory steps and Carriage controls for knitting multi-coloured tuck and slip stitches are the same as for single colour work.

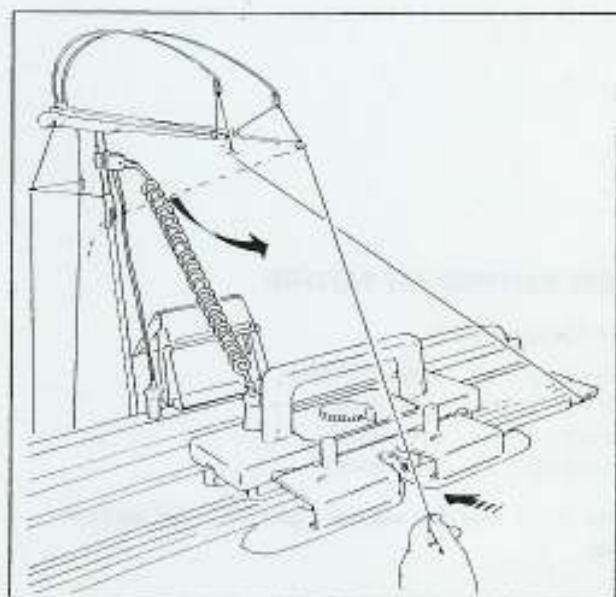
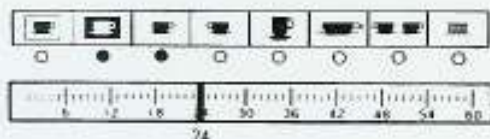

WHILE KNITTING THE PATTERN

Place colour 1 in Yarn Feeder ① and knit first two rows.

Change to colour 2 and knit two rows. Continue to knit, changing colours every two rows.

Place the yarn to be rested at the end of needle bed as illustrated below.

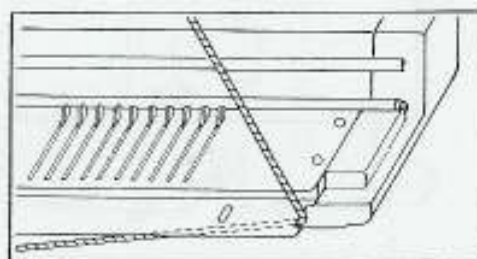

WEAVING

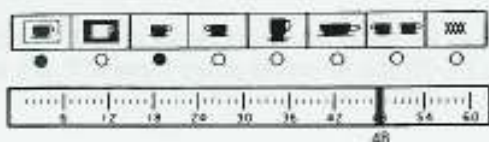
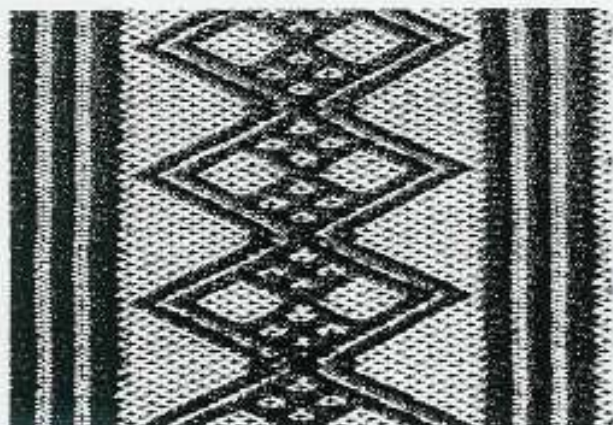

On the purl side of a fabric of stockinet knitted in medium yarn, a thick yarn is woven through the stitches giving a weaving effect.

Select a thin yarn for knitting yarn and thick yarn for weaving yarn.

The sample is knitted with the Pattern No. 10—(27).

Before knitting stitch pattern, follow the Preparatory Steps given on pages 19—22, instructions given below.

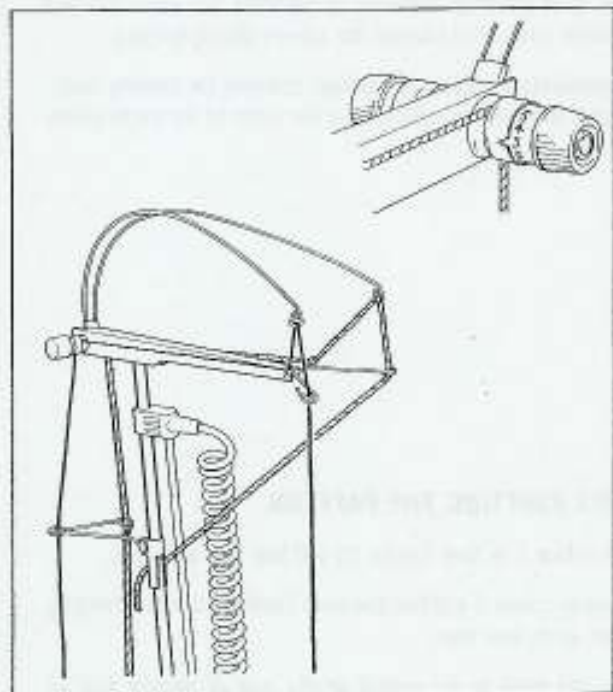

SETTING THE YARN

Thread thick yarn (weaving yarn) into the Auto-Tension and hook it into the Yarn Clip.

Set the Tension Dial for weaving yarn as follows.—
medium/thick yarn..... 2—3

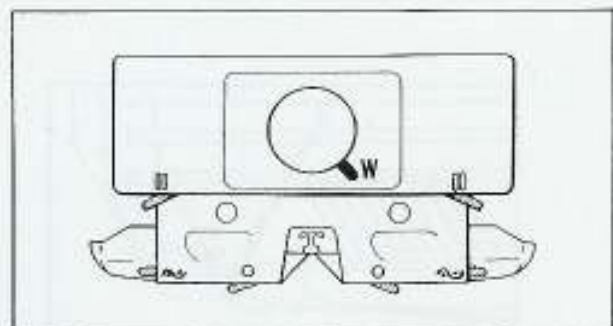

BEFORE KNITTING THE PATTERN

Set the Carriage controls.

Cam Lever..... W (WEAVING)
Russel Lever..... II (both)
Tuck Lever..... O (both)
Weaving Knob..... ~ (both)

Set the Stitch Dial one number higher than for stockinet knitting.

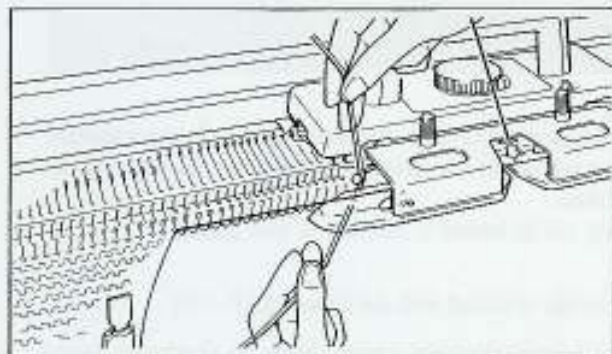

To start pattern knitting, follow the procedure below.

Take the thick yarn from the Clip on the Yarn Rod, and place it in the Weaving Yarn Holder on the leading side of the Carriage.

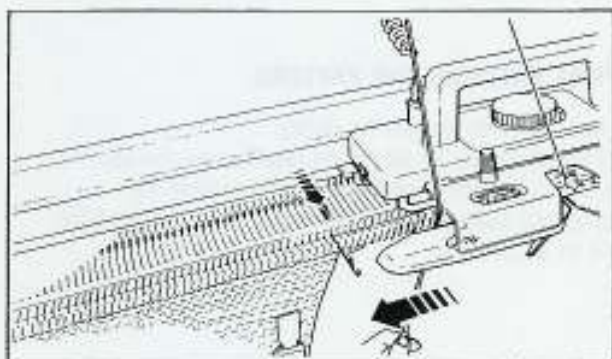

Holding the weaving yarn under the Arm, push the first knitting needle into D position, and then move the Carriage to the other side.

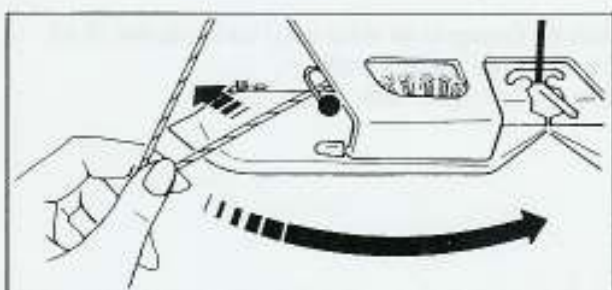

Before knitting the next row, bring the weaving yarn to the other side, and place it in the Weaving Yarn Holder.

Guide the weaving yarn under the Holder and then under the Arm to the other side of the Carriage.

At this step, push the Carriage in the original direction to free the weaving yarn from the brushes under the Arm.

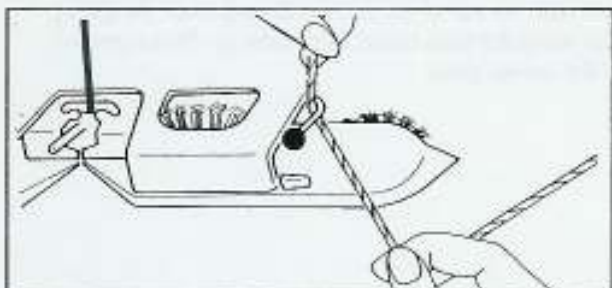

Place the weaving yarn inside the Holder on the leading side of the Carriage.

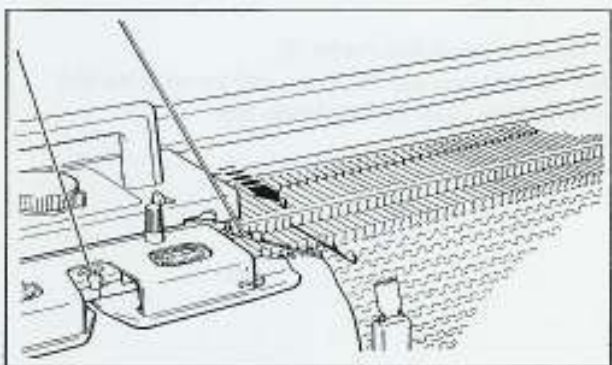

Push the first needle to D position for stockinet (or C position in partial knitting) and move the Carriage to the other side of the needle bed.

Repeat in the same manner, placing the weaving yarn into the Holder on the leading side before knitting the next row.

PLATING

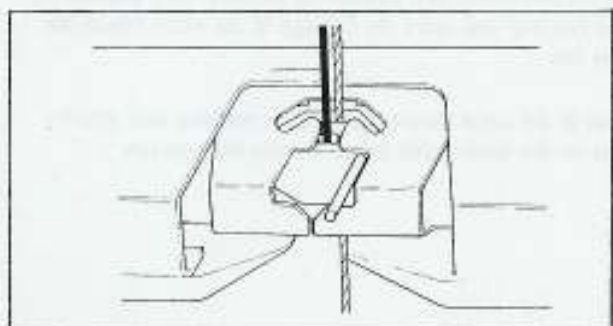
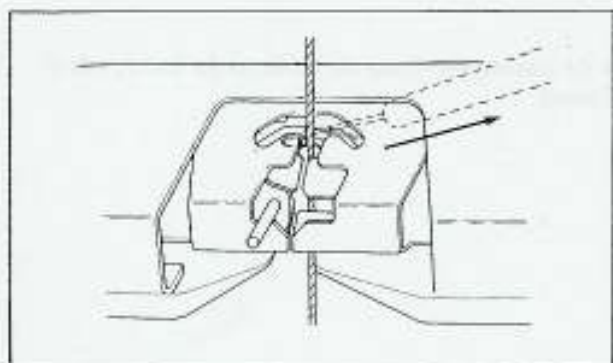
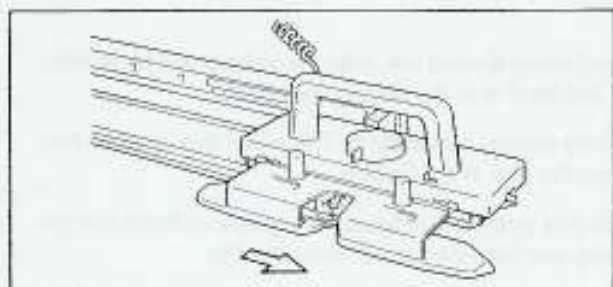
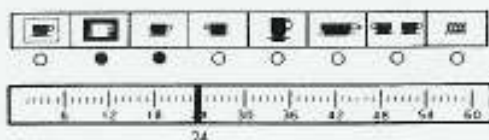

Two different colour yarns are knitted together. One yarn appears on one side whilst the second yarn appears on the other side of the fabric.

Plating can be knitted in stockinet or tuck stitch.

The sample is knitted with the Pattern No.1—(6).

Before knitting this stitch pattern, follow the Preparatory Steps given on pages 19—22, and the instructions given below.

BEFORE KNITTING THE PATTERN

Use two thin yarns together for plating.

The Stitch Dial must be set for the total for two thin yarns, as both yarns are knitted together. e.g. Refer to page 10.

If two type ③ Summer yarns are knitted together, the Stitch Dial should be set at 6—8.

Thread the Plating Yarn Feeder as follows.

1. Move the Carriage to the either end of the Needle Bed till the rear of the Yarn Feeder is visible. Open the Yarn Feeder Gate.
2. Put the plating yarn into the Yarn Feeder ①, insert the Tappet Tool from the rear of the Yarn Feeder and catch the plating yarn, and pull it down behind Yarn Feeder ①. Tie the yarn end to the nearest clamp.
3. Set the main yarn in Yarn Feeder ②. When the main yarn and the plating yarn are set in the Yarn Feeder properly, close the Yarn Feeder Gate.

PUNCH LACE

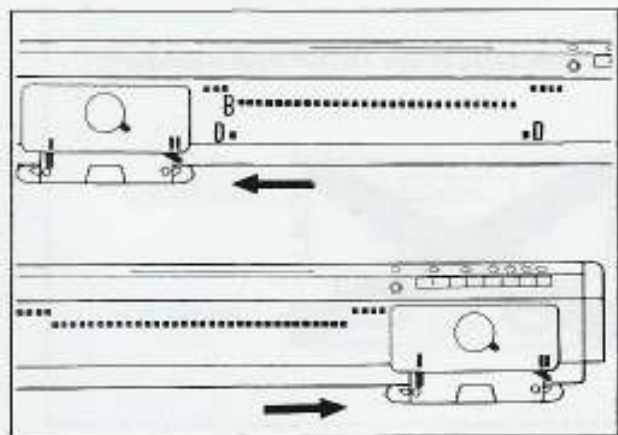
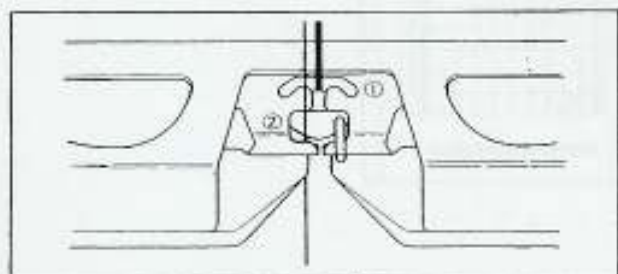
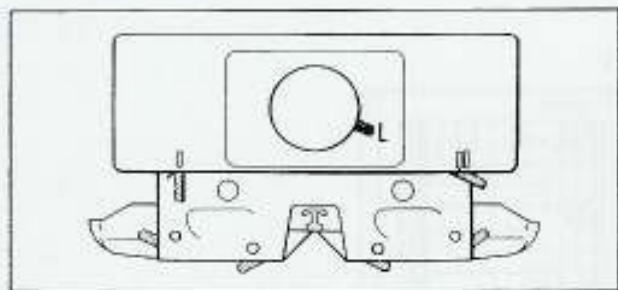
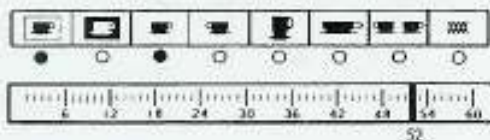
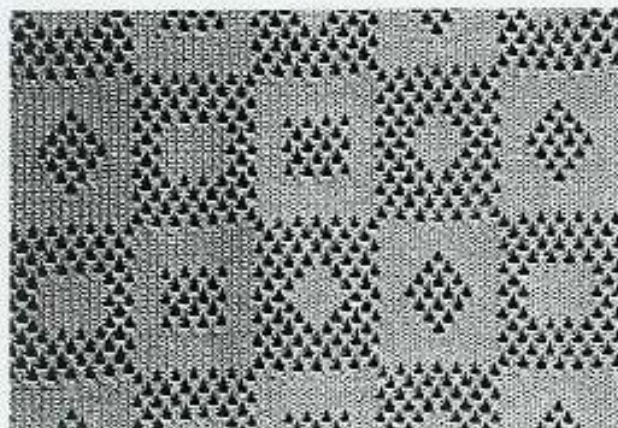

This type of lace pattern is knitted with main yarn, and either transparent nylon thread, or sewing cotton.
The sample is knitted with the Pattern No.9—(26).

Before knitting this stitch pattern, follow the Preparatory Steps given on pages 19—22, and instructions below.

KNITTING HINTS

To prevent the nylon thread becoming loose, cover the cone with the stop-net or with the piece of stocking cloth.



BEFORE KNITTING THE PATTERN

Set the Carriage controls.

Cam Lever..... L (PUNCH LACE)
 Russel Lever..... I (left)
 II (right)
 Tuck Lever..... O (both)
 Weaving Knob..... O (both)

Thread nylon thread or cotton into the Auto-Tension and into the Yarn Feeder ②.
 (Tension Dial for nylon thread or cotton..... 7)

WHILE KNITTING THE PATTERN

Push one needle at both edges of the knitting to D position.

Knit from right to left. (The end needles will not knit.)

Knit from left to right. (The end needles will be knitted back to B position.)

Do not fail to push the two end needles to D position before you move the Carriage from right to left.

Pushing the two end needles to D position ensures that the edges of the knitting are neat.

LACE CARRIAGE

The Lace Carriage is available as an optional accessory.

LACE CARRIAGE

- 1 Curl Cord Socket
- 2 Handle
- 3 Stitch Dial
- 4 Release Lever
- 5 Lace Arm
- 6 Arm Nut
- 7 Cam Lever
- 8 Yarn Feeder

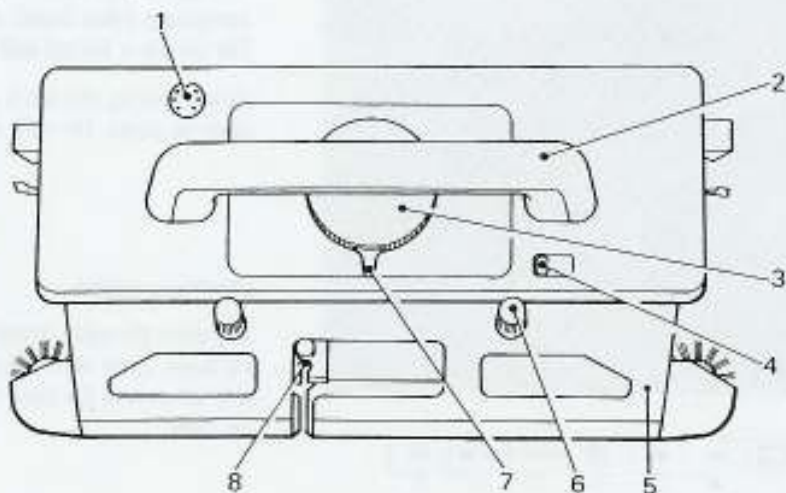

ACCESSORIES

- 1 Wide Claw Weight (3)
- 2 Lace Pattern Card (5)

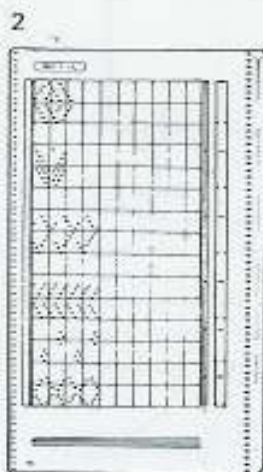
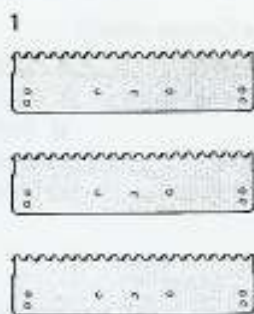

IMPORTANT:

Do not use the Lace Arm on the standard Carriage, or the standard Arm on the Lace Carriage. This will result in damage to the Arm or the needles.

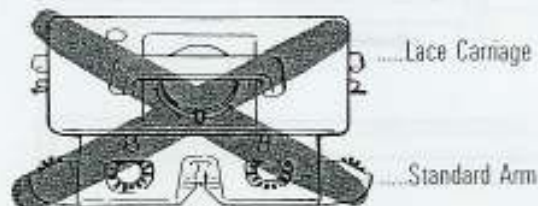
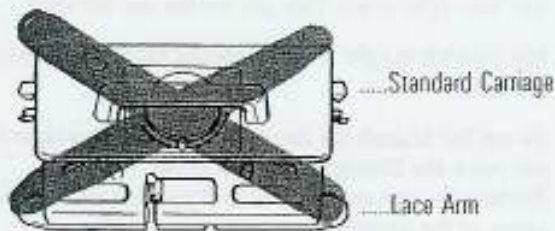

SETTING THE LACE CARRIAGE ON THE NEEDLE BED

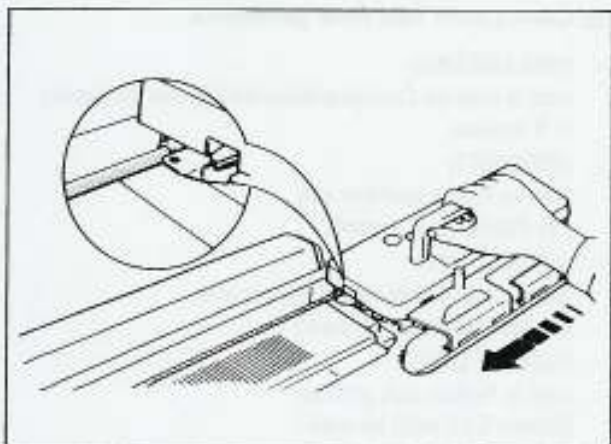

Switch "OFF" the machine, disconnect the Curl Cord from the standard Carriage. Remove the standard Carriage from the needle bed. Take out the Lace Carriage with Lace Arm attached from the Box, raise the Handle and set it on the Needle Bed as shown.

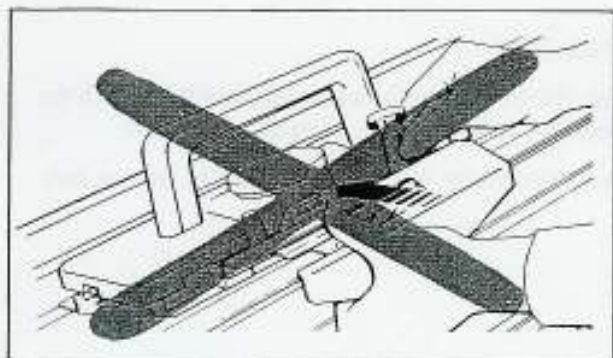

IF THE RIBBER HAS ALREADY BEEN CONNECTED WITH THE KNITTER, follow the instructions given below to use the Lace Carriage on the Knitter.

- DO NOT attach the Ribber Arm to the Lace Carriage.

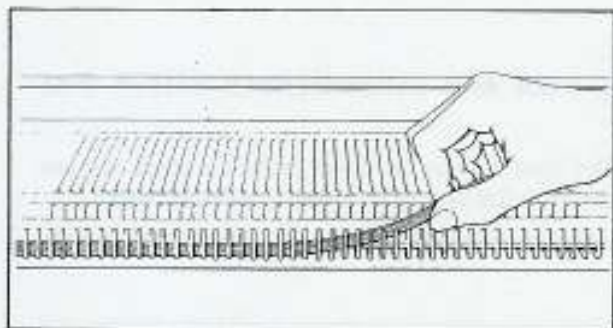

- Remove the Close Knit Bar from the Knitter Needle Bed if it is in use.

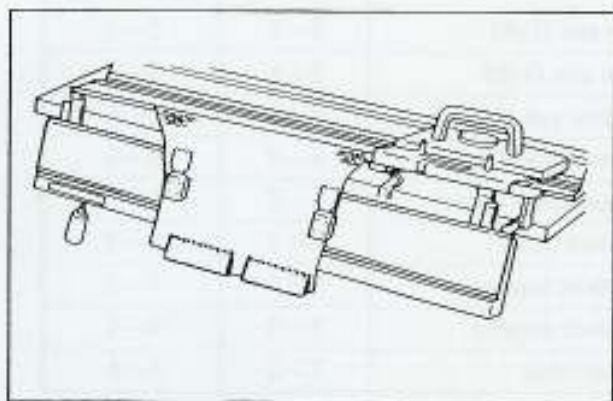

- To knit the lace fabric with the Ribber attached, drop the Ribber to its lowest position and cover the needle bed.
(Ribber Bed Covers are available as an optional accessory.)

CAM LEVER AND STITCH DIAL

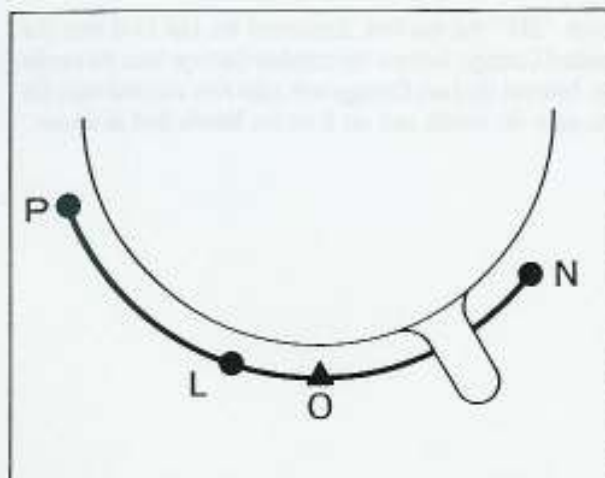

The Cam Lever has four positions

- N — (NON-KNITTING)
used to pass the Carriage without knitting over the needles in B position.
- O — (STOCKINET)
used to knit in stockinet only.
(No Pattern Card is used.)
- L — (NORMAL LACE)
used to knit normal lace stitch patterns.
(Pattern Card must be used.)
- P — (FASHION LACE)
used in fashion lace patterns.
(Pattern Card must be used.)

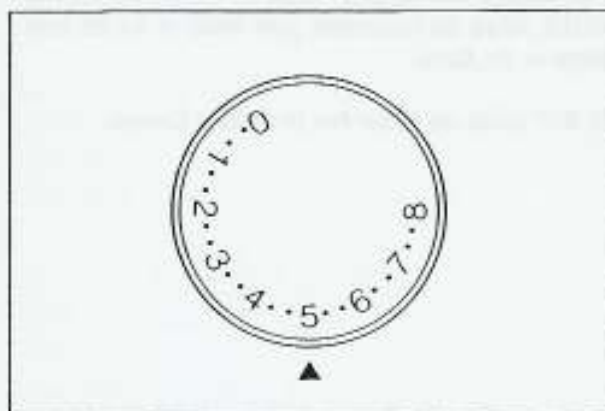

Stitch Dial

Stitch Dial for the Lace Carriage is numbered 0—8. Each dot represents a different tension, giving 25 settings in all.

The selected number of the Stitch Dial must be set at ▲ mark.

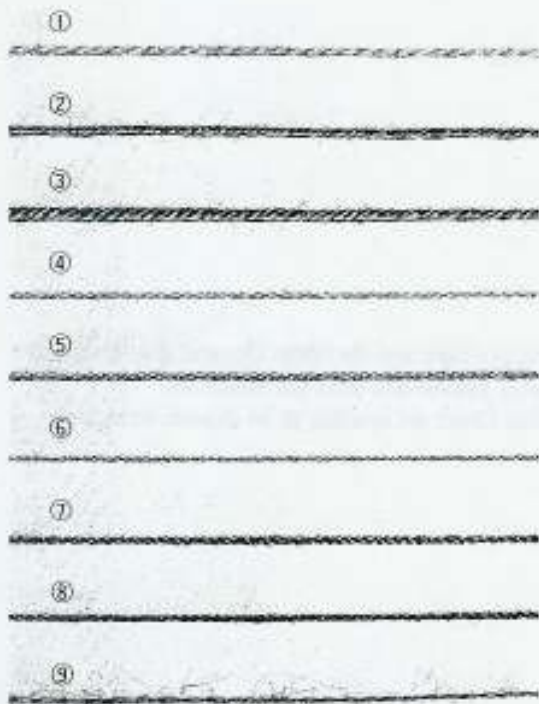

TYPE OF YARN AND RECOMMENDED STITCH DIAL SETTING

Recommended types of yarns are shown opposite in actual size, and recommended Stitch Dial settings are shown in the table below:

Do not use very heavily textured or thick mohair yarn for the lace stitch patterns.

Type of yarn	Stitch Dial (stockinet)	Stitch Dial (lace knitting)
① Thin yarn (2-ply)	2—3	3—4
② Light yarn (3-ply)	3—5	4—5
③ Medium yarn (4-ply)	4—6	5—6
④ Cotton thread (thin)	3—4	4—5
⑤ Cotton thread (regular)	4—5	5—6
⑥ Synthetic (thin)	2—3	3—4
⑦ Synthetic (regular)	3—4	4—5
⑧ Synthetic (regular)	3—4	4—5
⑨ Mohair (thin)	3—5	4—5

CAST-ON AND STOCKINET KNITTING — on the Lace Carriage —

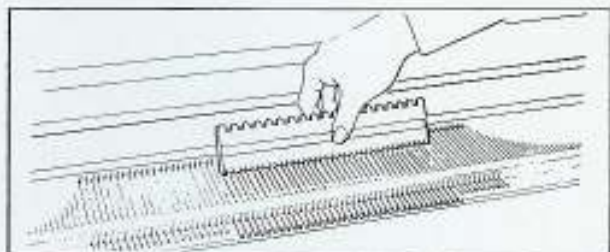

Needles must never be pushed to D or C position while the Lace Carriage is in use.

Using the Needle Pusher, push up 70 needles (35 needles on both sides of the centre) to B position.

To knit in stockinet using the Lace Carriage, the machine does not need to be switched on.

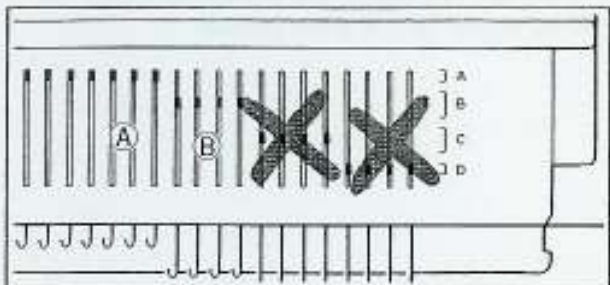

IMPORTANT

When you knit with the Lace Carriage, the needles must be aligned in B position only. A position is used for holding stitches.

Do not push the needles into C or D position. This will damage the needles.

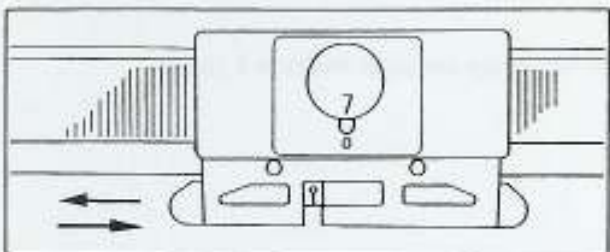

Set the Carriage as follows and move it twice across the needles to align them correctly in B position. Finish with the Carriage at the right.

Stitch Dial..... 7
Cam Lever..... 0 (STOCKINET)

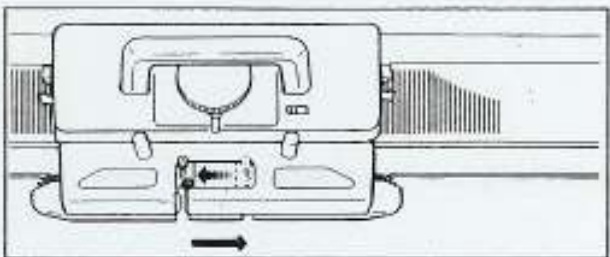

The Yarn Feeder moves during knitting. After aligning needles, check that the Yarn Feeder is at the left side. If it is not, move the Carriage a little more to the right.

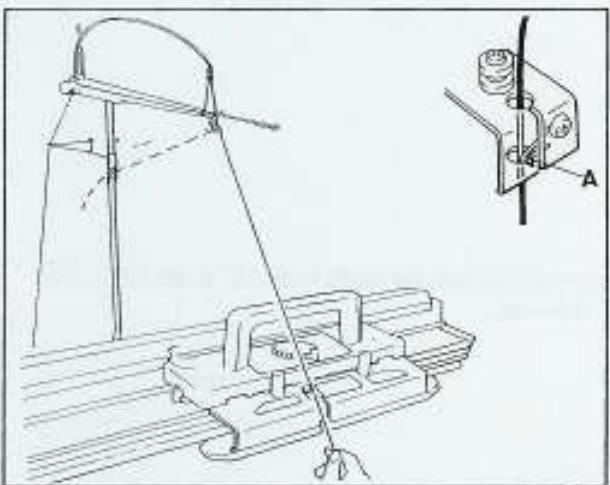

Thread the yarn through the Auto-Tension and into the Yarn Feeder.

The yarn must be correctly set behind the Guide Pin "A" in the Yarn Feeder.

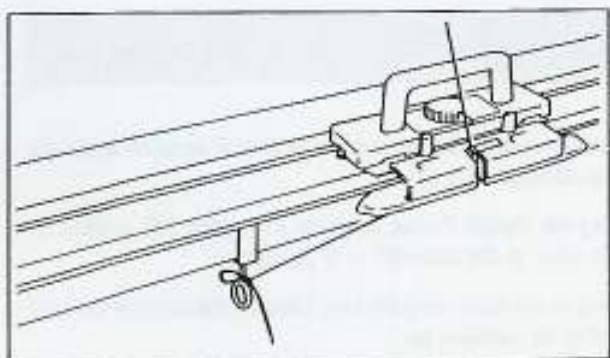

Fasten the yarn end to the nearest Clamp.

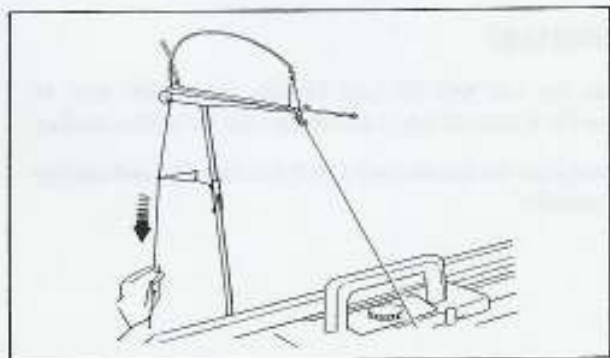

Take up the slack by pulling the yarn back from behind the Yarn Rod till the Tension Spring is almost horizontal.

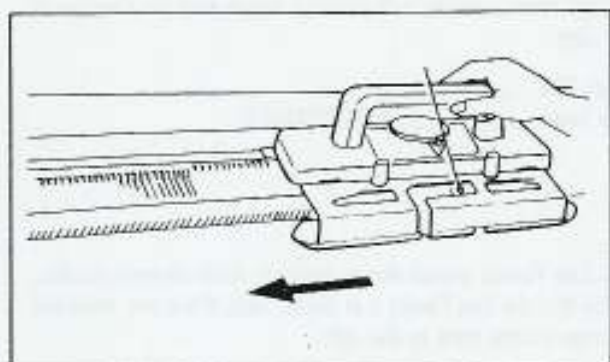

Move the Carriage across the needles in B position.

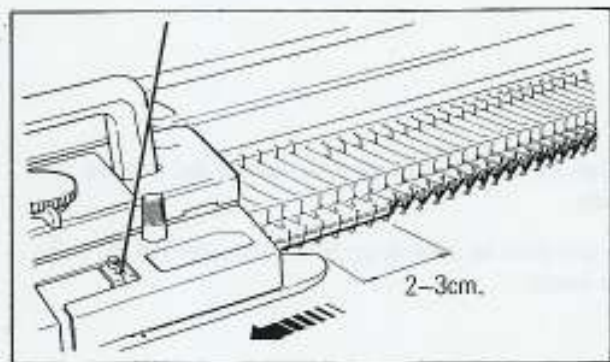

Take the Carriage past the end needle by about 2—3cm.

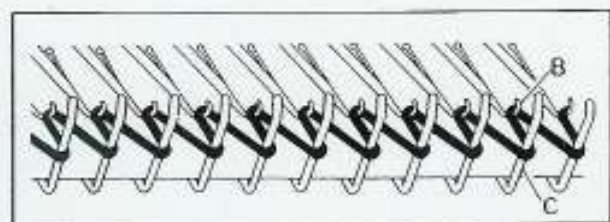

The yarn zigzags from the needle hooks "B" to the sinker posts "C" alternately.

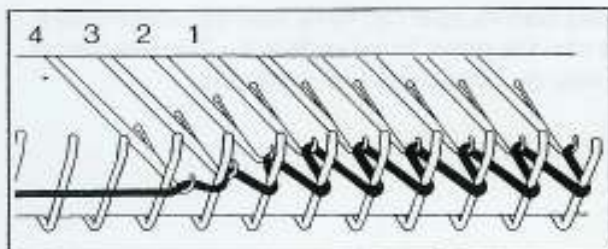

At the end of the cast-on row, the yarn tends to be pulled up by the Tension Spring, and the zigzag may become uneven.

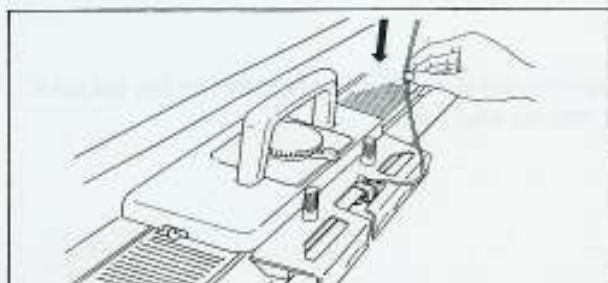

To correct the irregular zigzag yarn, pull down the yarn from the Tension-Spring toward the Yarn Feeder.

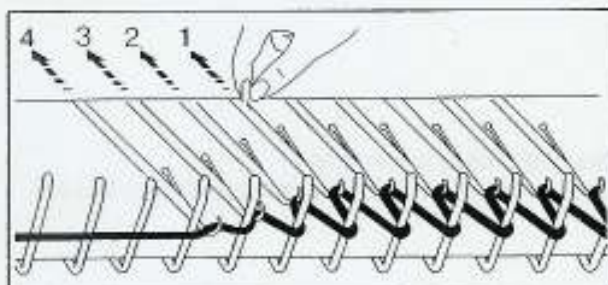

Push the needles by hand back to B position one by one, starting with the inner needle, and working to the outer edge.

Hint: To eliminate the irregular hooking of the yarn at the end of the cast-on row, pull down the yarn slightly from the Tension-Spring with your hand before the Carriage completes the cast-on row.

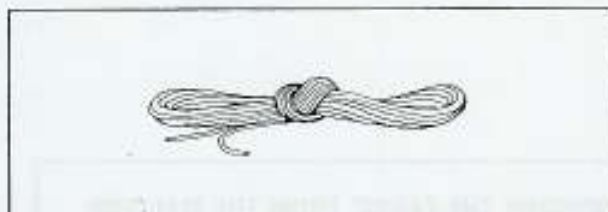

Take out the Ravel Cord from the Accessory Box, and untie it. Place one end of the Ravel Cord in the yarn clip at the end of the needle bed, and lay the Cord over the zigzag yarn between the sinker posts and the needle hooks.

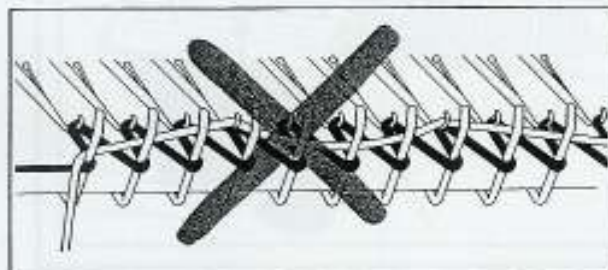
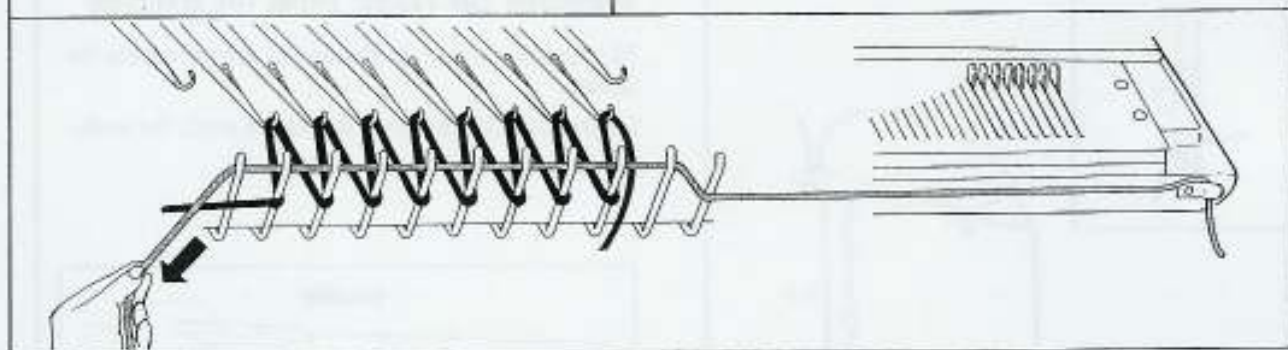

If the Ravel Cord is caught on the needle hook, the cast-on will not work correctly.

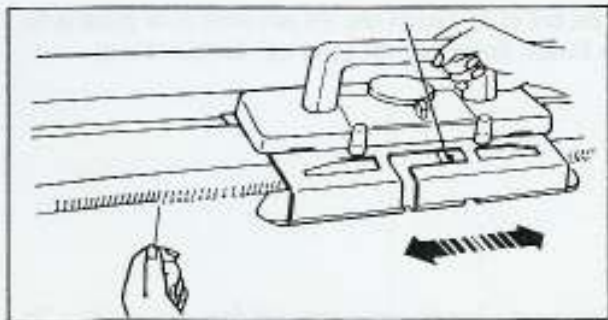

Pulling down the Ravel Cord tightly, move the Carriage slowly to the other side, passed the end needle by 2—3cm. Then continue to move the Carriage to and fro several times.

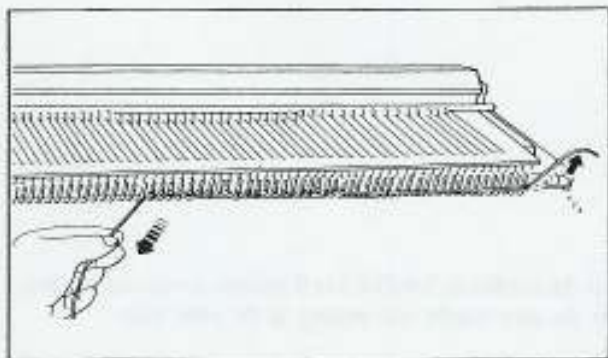

Release the end of the Ravel Cord from the Yarn Clip, and pull it out from the other end.

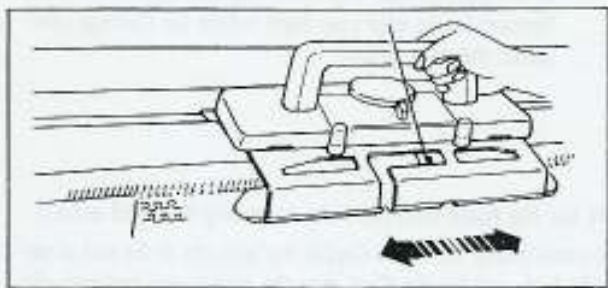

Cast-on (open edge) is completed. Continue to knit about 30 rows by moving the Carriage back and forth.

Hang the Claw Weights on both sides of the fabric.

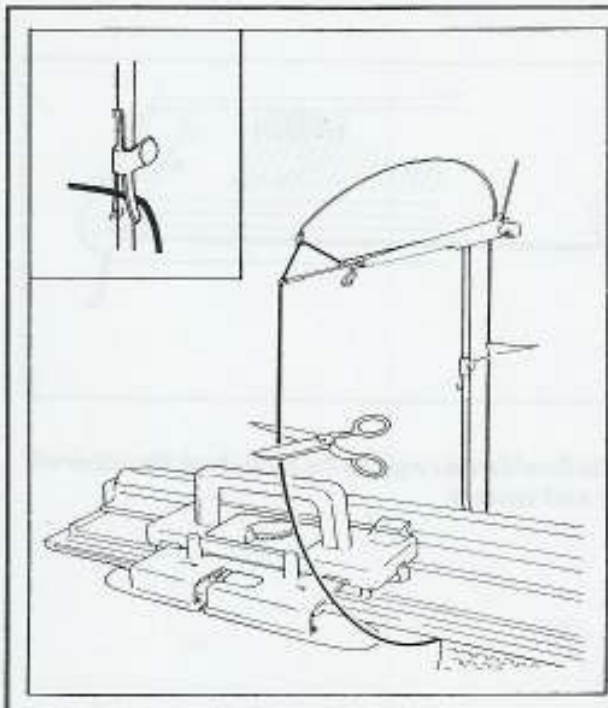

REMOVING THE FABRIC FROM THE MACHINE

Take out the yarn from the Yarn Feeder, and cut it above the Carriage.

Set the Cam Lever to 0 mark, and move it across the needle. The fabric will be released from the needles.

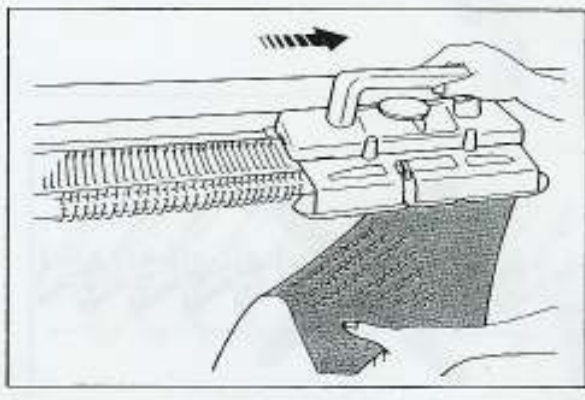

KNITTING LACE STITCH PATTERNS

Five sheets of Pattern Cards, containing 20 patterns in total, for lace stitch patterns are packed with the Lace Carriage.

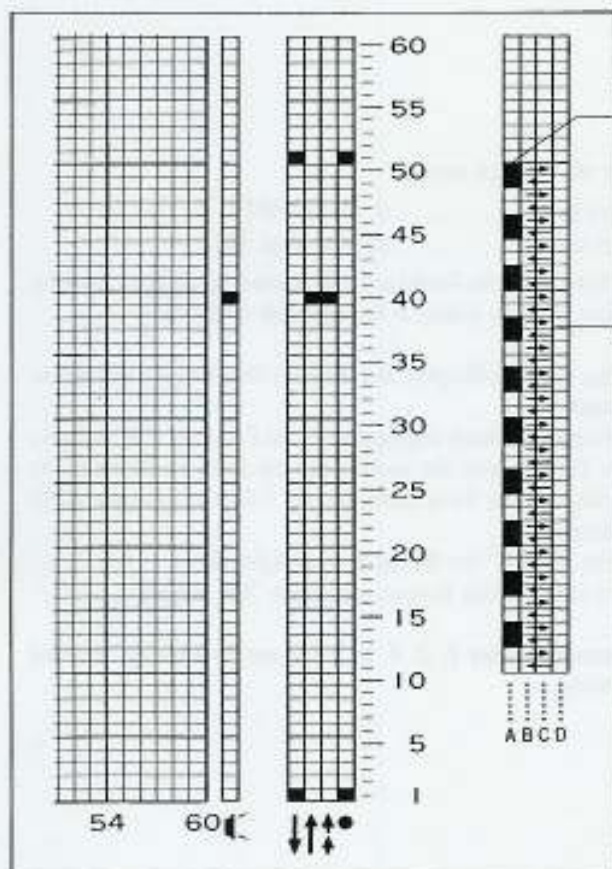

The Pattern Cards for the lace stitch patterns have the following additional marks on them.

FASHION LACE ROWS

On these rows, the Carriage transfers stitches only, and does not knit.

KNITTING DIRECTION MARK

IMPORTANT:

The knitting direction of the Carriage must correspond with the arrow marks, when the Inspection Button light is off.

In lace stitch patterns, the needles corresponding with the black area of the Pattern Card are selected and their stitches are transferred onto adjacent needles.

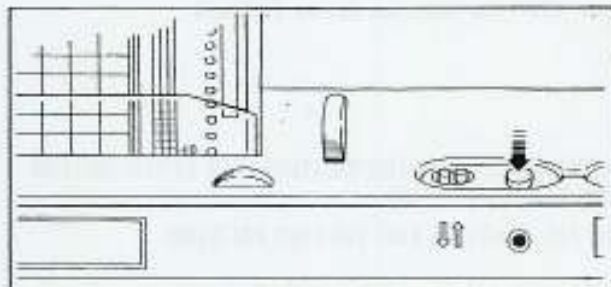

PREPARATORY STEPS FOR LACE KNITTING

Connect the Curl Cord to the Lace Carriage and set the Card Stand referring to pages 19, 20.

Switch "ON" the machine, and push "ON" the Inspection button. (light on)

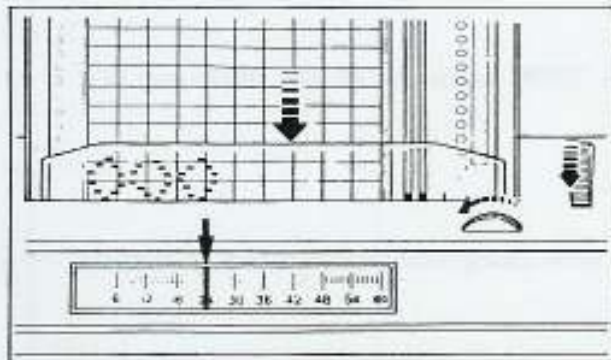

Set the Pattern Card, and set the Pattern Width Indicator.

The Pattern Width Indicator must correspond with the Δ mark given for the selected pattern.

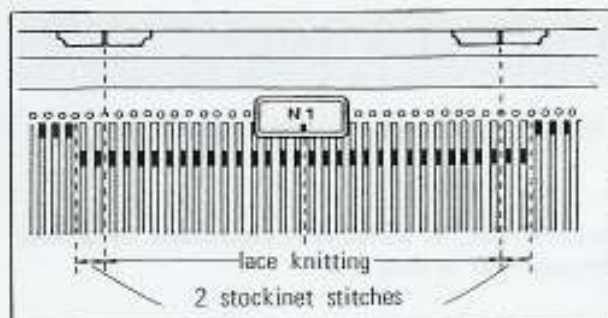

Align the needles in B position.
Set the Needle-1 Cam.
Set the Point Cams to eliminate two working needles at both edges.

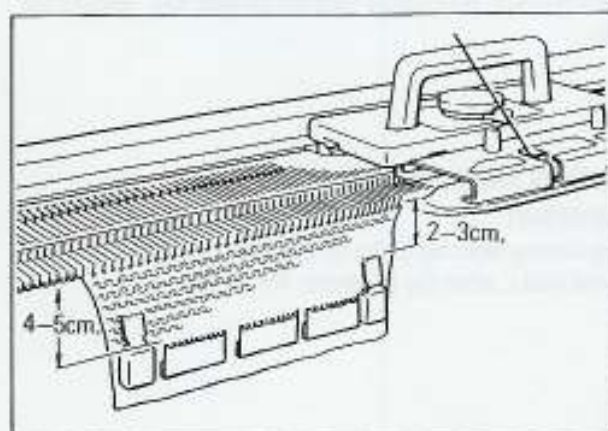

Set the Carriage controls.
Cam Lever..... 0 (STOCKINET)
Stitch Dial..... (refer to page 36)
Cast on using the Ravel Cord and continue to knit in stockinet for about 30 rows ending at the right side of the fabric.

Hang the Claw Weights, and the Wide Claw Weights on them as shown.
If knitting is already in progress, set the Cam lever to N, and pass the Carriage over the working needles twice to memorize the settings of the Point Cams, Needle 1 Cam and Pattern Width Indicator.
Push "DOWN" the Button 2, (right light on)
The other Pattern Buttons must be in "UP" position.

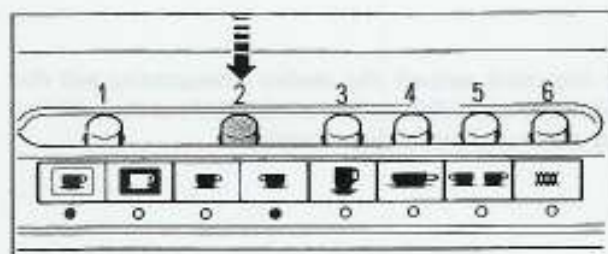

Pattern Buttons 1, 3, 4, 5, 6 can not be used for the lace knitting.

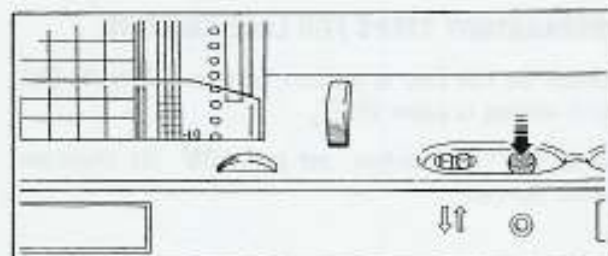

Push "OFF" the Inspection Button. (light off)

PREPARATORY STEPS FOR KNITTING LACE STITCH PATTERN
HAVE BEEN COMPLETED.
YOU ARE READY TO KNIT THE LACE PATTERNS.

IMPORTANT TO NOTE:

- When knitting in face patterns, the Pattern Button 2 must be in "DOWN" position and the other Buttons must be in "UP" position.
- Set the Point Cams to exclude two working needles at both edges.
- Be sure to have the Carriage at the right side of the working needles before starting to knit lace stitch patterns, to correspond with the knitting direction arrow marks on the Pattern Card.

PLAIN LACE

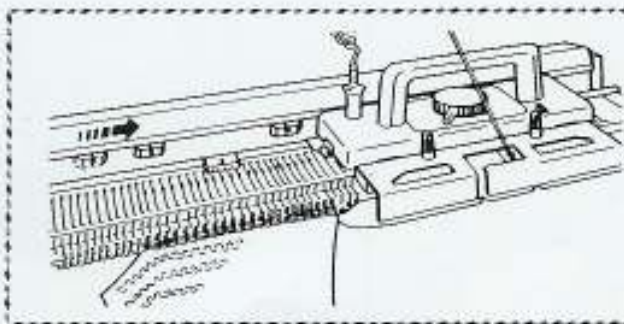
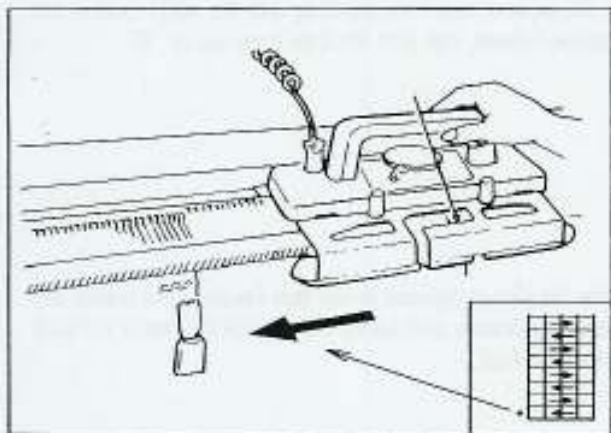
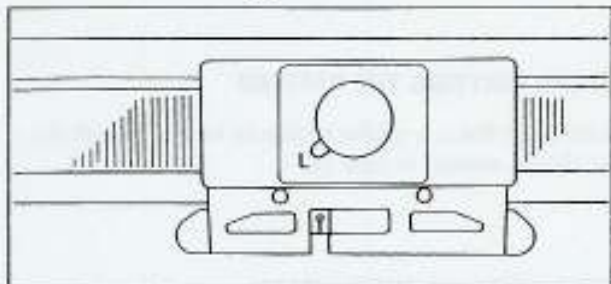
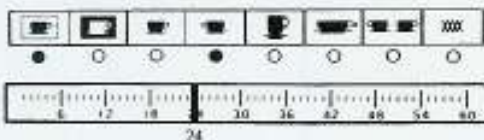
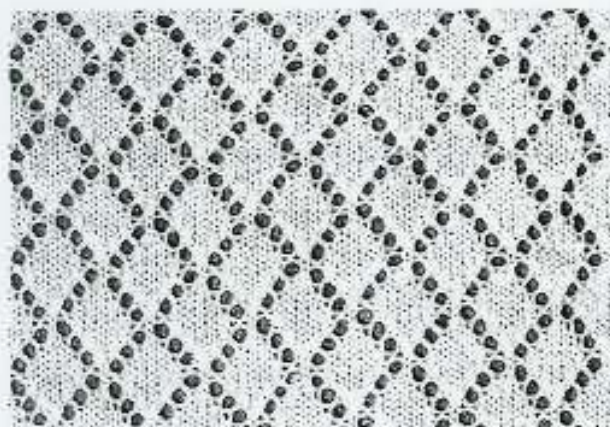

For plain lace, the lace Carriage transfers stitches and knits in one row.

The sample is knitted with the Pattern No. 1—L—(1).

Following the Preparatory Steps given on pages 41—42, prepare for knitting the lace pattern, finish with the Carriage at the right side of the working needles.

BEFORE KNITTING THE PATTERN

Set the Carriage controls.

Cam Lever.....L
Stitch Dial.....refer to page 36.

WHILE KNITTING THE PATTERN

Knit slowly and at an even speed following the arrow direction mark given on the Pattern Card.

If the direction of the Carriage does not correspond with the arrow marks, the lace stitch pattern will be knitted incorrectly.

In lace knitting, all shaping must be done on the side opposite to the Carriage. The Point Cam must be moved to its new position (2 stitches in from the edge of the knitting) before knitting the next row.

FASHION LACE

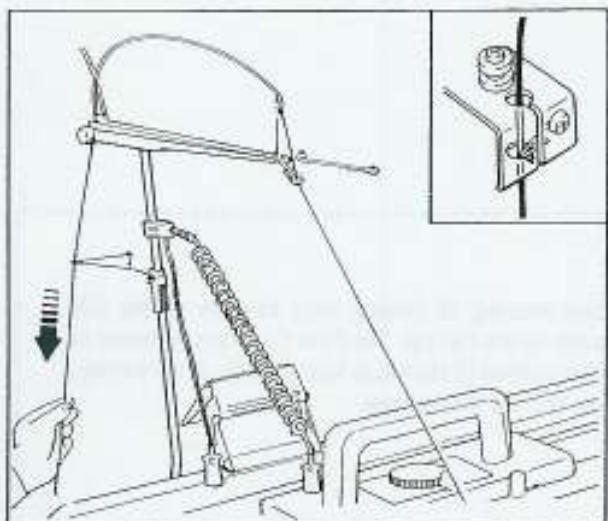
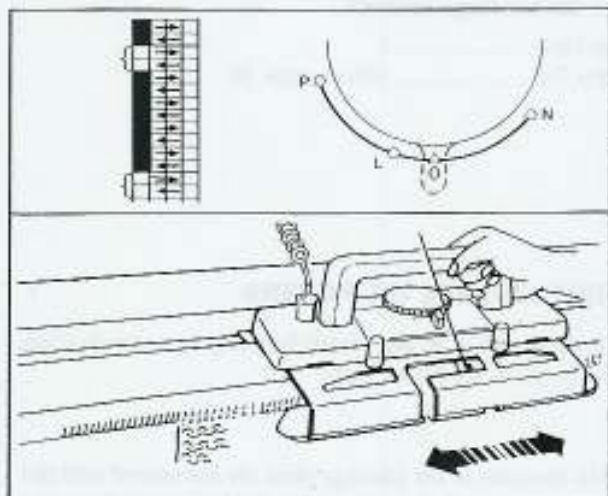
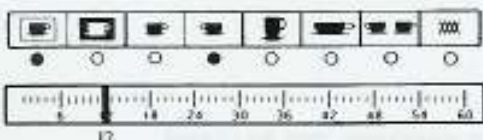
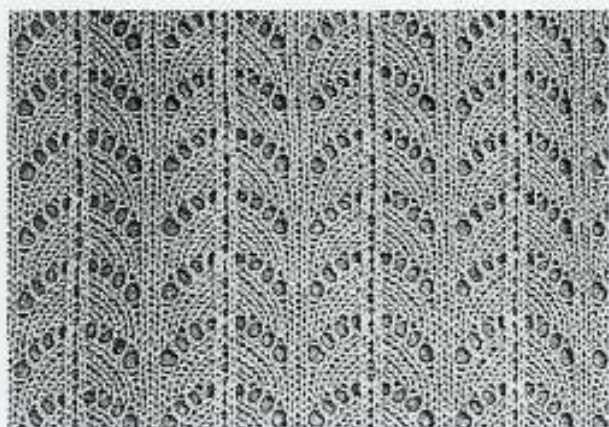

On marked rows, the Carriage transfers stitches only, and does not knit.

The sample is knitted with the Pattern No.4—L—(15).

Following the Preparatory Steps given on pages 41—42, prepare for knitting lace patterns.

Before starting pattern, have the Carriage at the right side of the working needles.

BEFORE KNITTING THE PATTERN

Set the Stitch Dial to a suitable number for knitting the yarn you have chosen, referring to page 36.

WHILE KNITTING THE PATTERN

For the pattern rows corresponding with the white rows in the Notation Column, knit with the Cam Lever set at "0".

When the yarn is replaced in the Yarn Feeder, set it behind the Guide Pin correctly, and pull up the slack on the yarn at the back of the Yarn Rod.

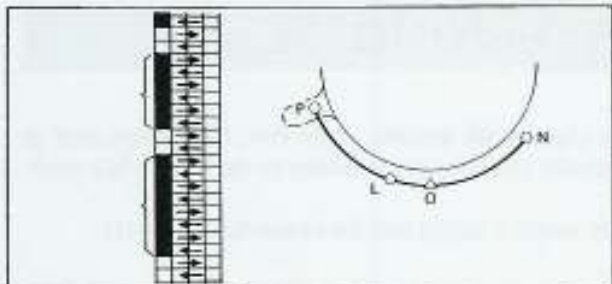

For the pattern rows corresponding with the black marks in the Notation Column, move the Carriage back and forth with the Cam Lever set at "P", and without yarn in the Yarn Feeder.

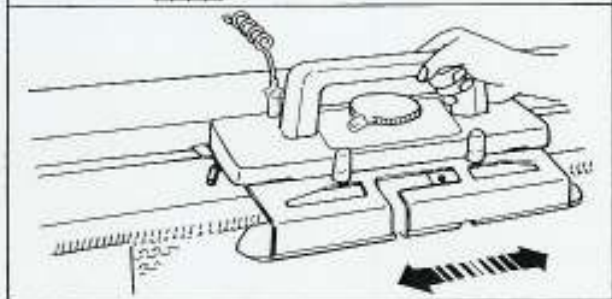

Selected stitches are transferred onto their adjacent needles, and Row Counter will not move while transferring stitches is in progress. No stitches are knitted during this procedure.

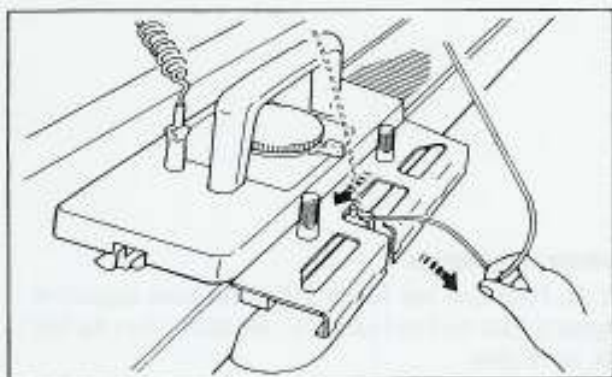

When the black mark in the Notation Column shows above the Card Slot, remove the yarn from the Yarn Feeder. The Carriage should be at the right side.

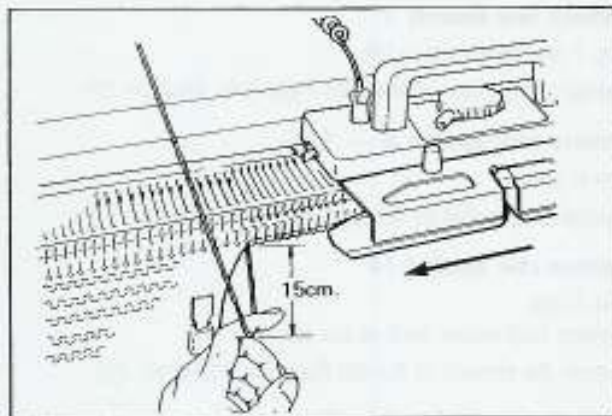

The yarn removed from the Yarn Feeder must be held away from the Arm to prevent it becoming tangled.



When the yarn is removed from the Yarn Feeder, DO NOT move the Carriage with the Cam Lever set at "L" or "O", as the fabric will be released from the needles.

SECTIONAL PATTERNING

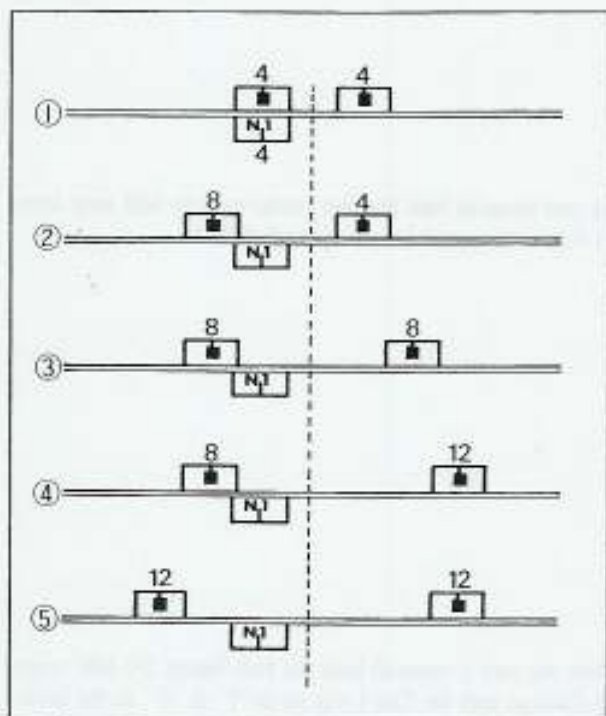
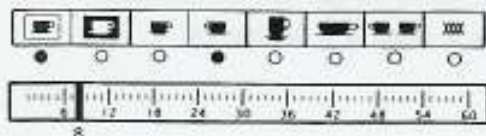
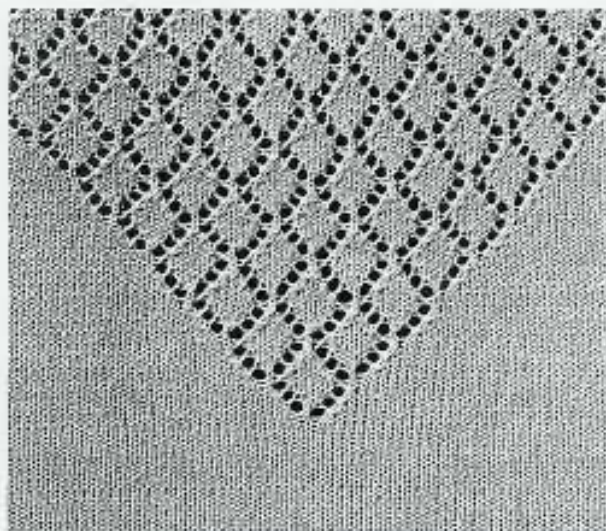

By changing the positions of the Point Cams, single motif or sectional patterning can be worked on the fabric in lace stitch.

The sample is knitted with the Pattern No. 1—L—(1).

Pattern row number 1 — 6

Set the Point Cam and Needle-1 Cam as shown opposite in diagram ① With the Cam Lever at "L", and starting from the right side, knit 6 rows.

Change the position of the Point Cam. (diagram ②)

Pattern row number 7

Knit 1 row from right to left.

Change the position of the right Point Cam. (diagram ③)

Pattern row number 8 — 13

Knit 6 rows.

Change the position of the right Point Cam. (diagram ④)

Pattern row number 14

Knit 1 row.

(Pattern Card moves back to the row 1.)

Change the position of the left Point Cam. (diagram ⑤)

Pattern row number 1 — 6

Knit 6 rows.

Change the position of the Point Cam.

Repeat the above steps, using the same principle.

By changing the position of the Point Cams, the pattern section can be increased in size. Only move the Point Cam at the side opposite the Carriage.

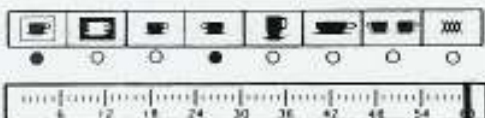
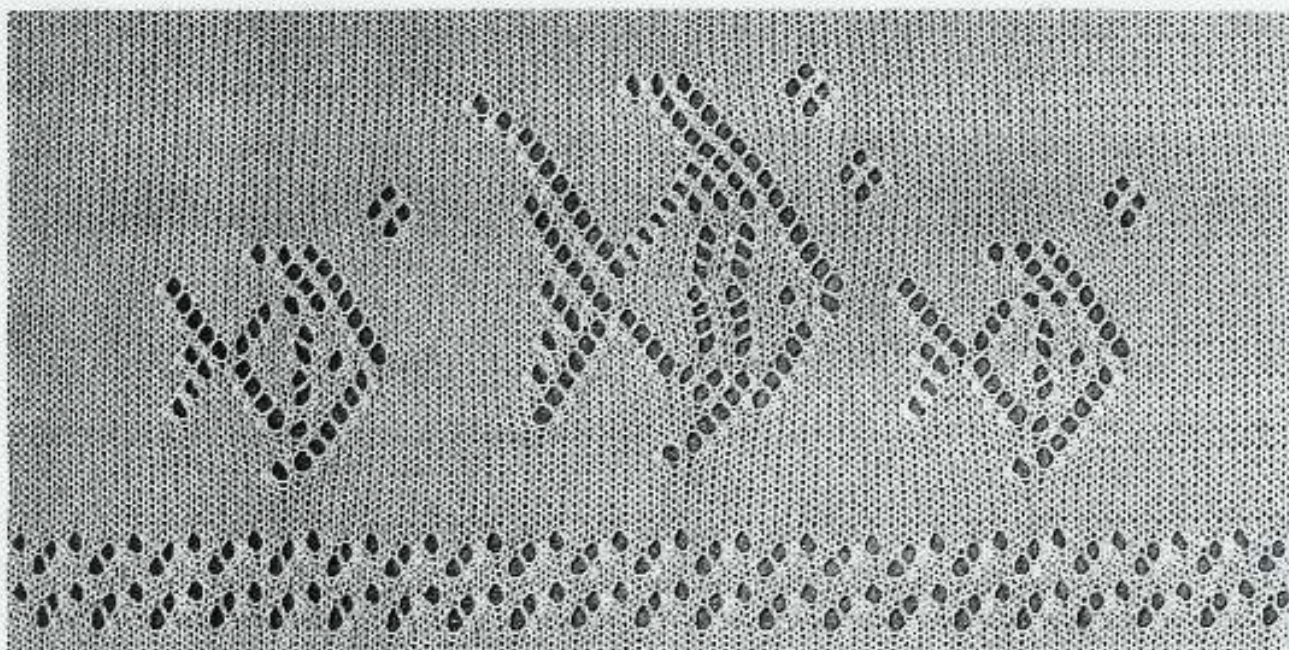

The sample is knitted with the Pattern No.3—L—(11).

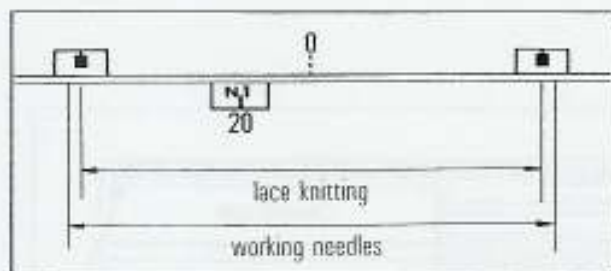

Pattern row number 1 — 11

Set the Point Cams and the Needle-1 Cam as shown opposite. Point Cams two needles in from the edge of the knitting. Knit with the Cam Lever at "L".

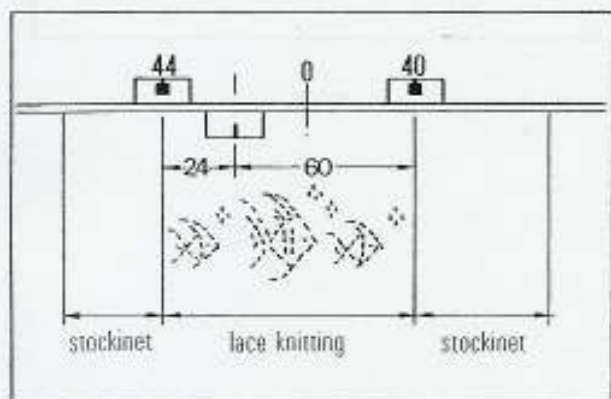

Pattern row number 12 — 68

Change the position for the Point Cams and the Needle-1 Cam as shown opposite and continue to knit in the same Cam Lever setting.

(It is not necessary to move the Carriage without knitting to memorize the new position, because there are 7 rows stockinet before the lace pattern begins again.)

When the Pattern Card has returned to the first row, set the Cam Lever to "0", and continue in stockinet.

REPACKING THE KNITTER

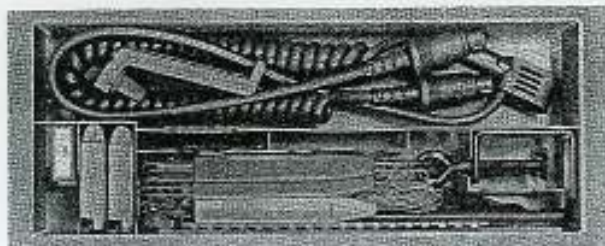

Replace the Accessories in the Accessory Box.

Remove the Pattern Card from the Pattern Card Panel.
Do not fold or bend it.

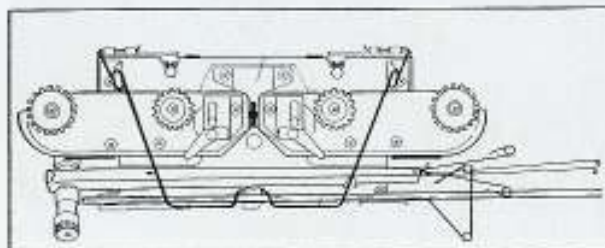

Remove the Auto-Tension and the Knitter Arm from the Knitter Carriage and pack them inside the Top Cover.

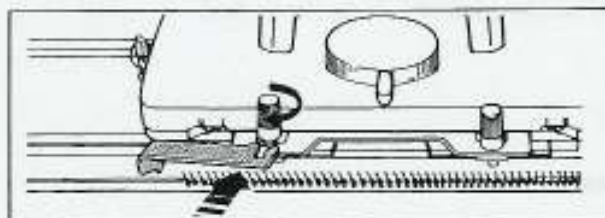

Secure the Carriage to the Needle Bed with the Carriage Fastener.

Lay the Carriage Handle down.

Replace the Accessory Box on the right end of the needle bed.

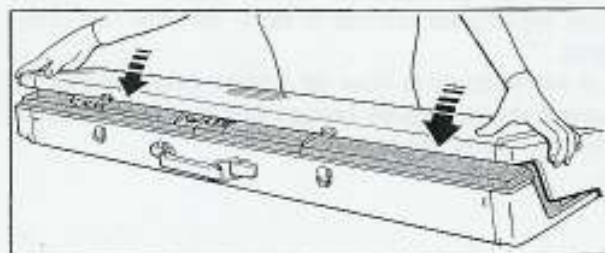
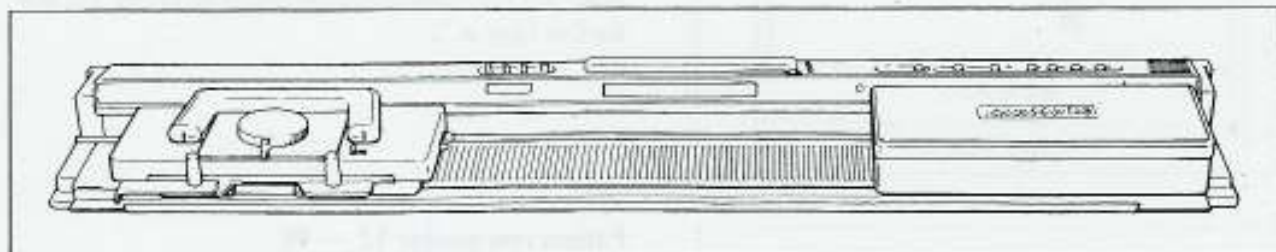

Place the Top cover onto the Needle Bed.

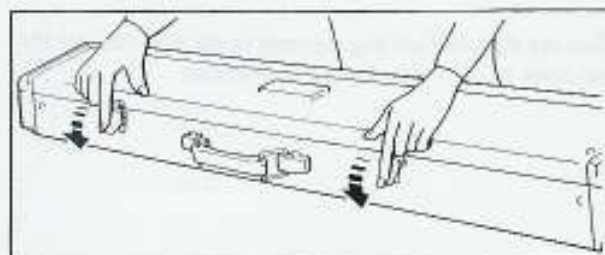

Fasten the latches.

TO STORE THE MACHINE

Keep the machine away from.

1. Too much moisture.
2. Abnormal change of temperature.
3. Salt or chemicals.

TO USE THE RIBBER

CONTENTS

	page
ACCESSORIES	50
SETTING THE RIBBER ON THE KNITTER	51
RIBBER NEEDLE BED	56
RIBBER CARRIAGE	58
RIBBER ARM	59
P CARRIAGE	60
YARN AND STITCH DIALS	61
OPERATION TABLE	62
CAST-ON AND KNITTING	64
CAST-ON FOR TIGHTER EDGE	69
REMOVE THE FABRIC FROM THE MACHINE	70
VARIOUS RIB STITCHES	
DOUBLE RIB	71
K1.P1. RIB	71
K2.P2. RIB	72
WIDE RIB	73
ENGLISH RIB	74
SWUNG ENGLISH RIB	74
VARIATION OF ENGLISH RIB	75
DOUBLE ENGLISH RIB	75
HERRINGBONE SWING	76
VARIATION SWING	77
TUBULAR KNITTING	79
PIN TUCK	79
TUCK RIB	80
DRIVE LACE	81
PILE KNITTING	83
TO USE YARN CHANGER WITH THE RIBBER	86
BASIC KNITTING	87
DOUBLE JACQUARD	92
KNITTING ON THE KNITTER USING YC5	95
REPACKING THE RIBBER	97

ACCESSORIES

Of the accessories included with the Ribber, the following are needed when you use the Ribber on the Model 550 knitter.

Please be careful, when unpacking accessories, not to lose the Close Knit Bar (No.11).

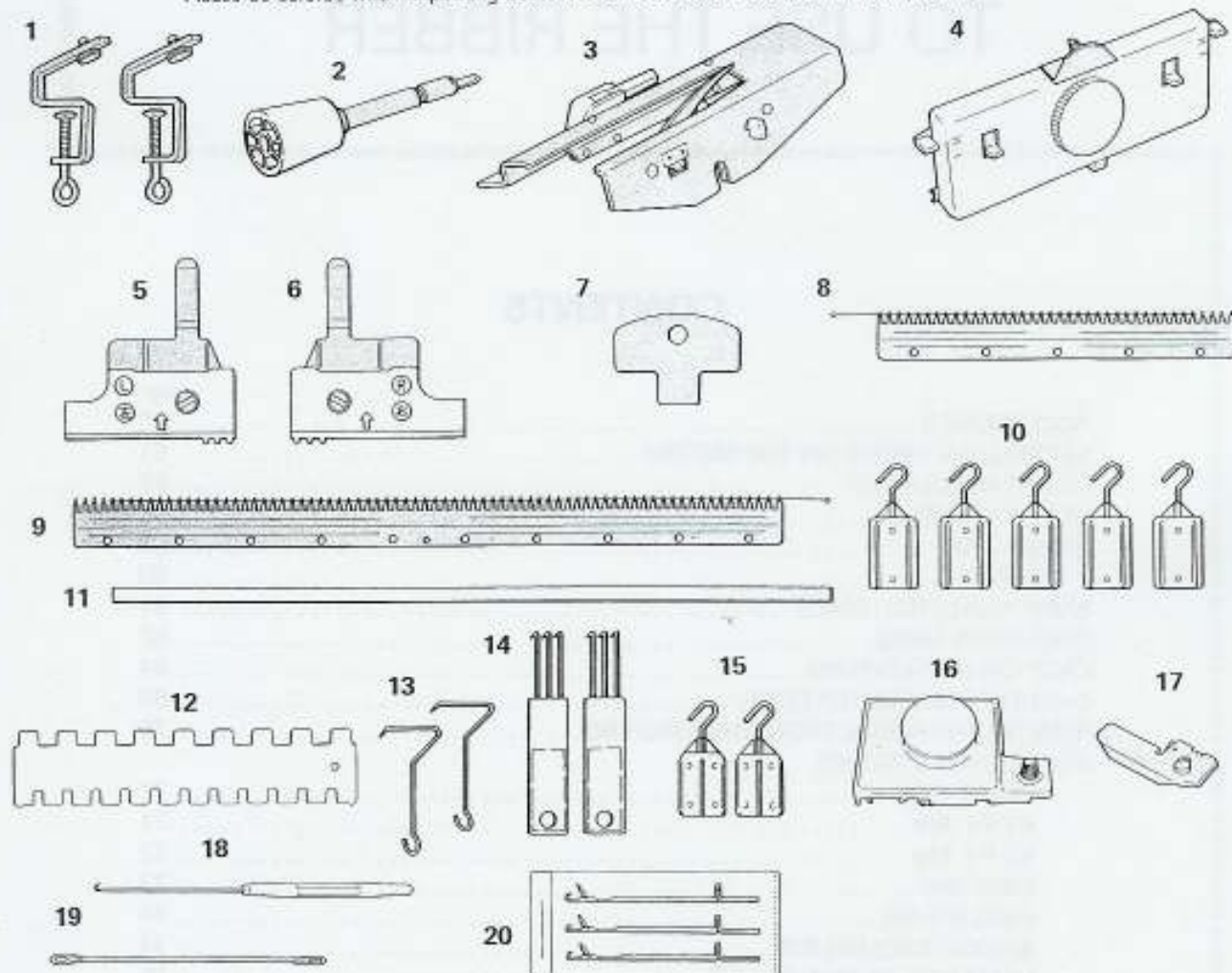

- | | |
|--------------------------|--|
| 1 Ribber Clamp | 11 Close Knit Bar |
| 2 Swing Handle | 12 Needle Pusher (2/1, 2/2) |
| 3 Ribber Arm | 13 Side Hanger |
| 4 Ribber Carriage | 14 Hanger Comb |
| 5 Auxiliary Piece (L) | 15 Edge Weight |
| 6 Auxiliary Piece (R) | 16 P Carriage |
| 7 Screw Driver | 17 P Presser |
| 8 Cast-on Comb (short) | 18 Hook Tool |
| Cast-on Wire (short) | 19 Double-eye Transfer Tool |
| 9 Cast-on Comb (long) | 20 Spare Needle Envelope (incl. 3 needles) |
| Cast-on Wire (long) | |
| 10 Ribber Weight (large) | |

SETTING THE RIBBER ON THE KNITTER

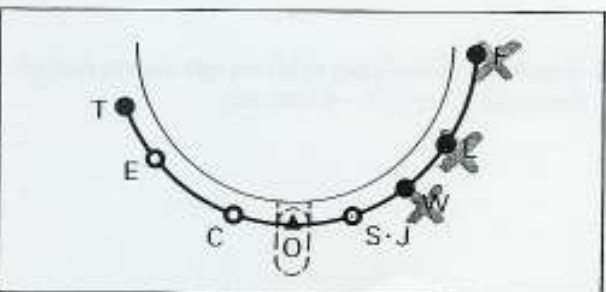
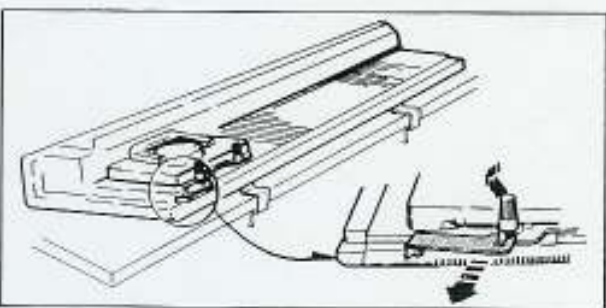
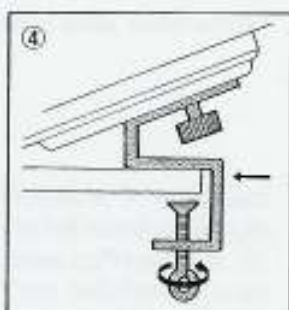
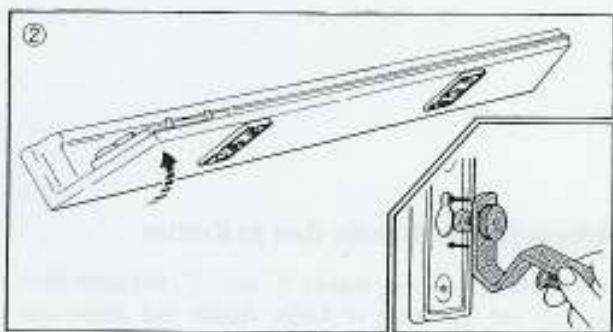
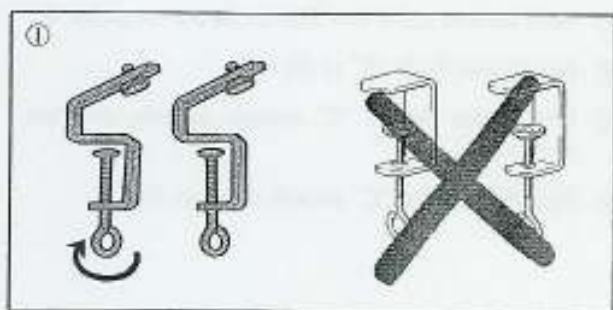

Set up Knitter

Set up Knitter referring to pages 3—4, but observe the following differences

1. Fasten the Knitter to table, using Ribber Clamps instead of Knitter Clamps.
 - ① Take Ribber Clamps and turn screws in arrowed direction as far as they go.
DO NOT USE KNITTER CLAMPS.

- ② Raise front of Knitter and insert screw head into keyhole slot.

- ③ Pull clamps upwards and tighten screws.

- ④ Place clamps on table edge and push them backwards until they are against the table.

Tighten clamps firmly by turning screws in arrow direction.
DO NOT OVER TIGHTEN.

2. Remove Carriage Fastener.

DO NOT ATTACH KNITTER ARM TO CARRIAGE.
LACE CARRIAGE MUST NOT BE USED WITH RIBBER.

3. Set Cam Lever to "O" (STOCKINET).

IMPORTANT:

Cam Lever should never be set to "L" (PUNCH LACE), "F" (FAIR ISLE) or "W" (WEAVING) when using Ribber.

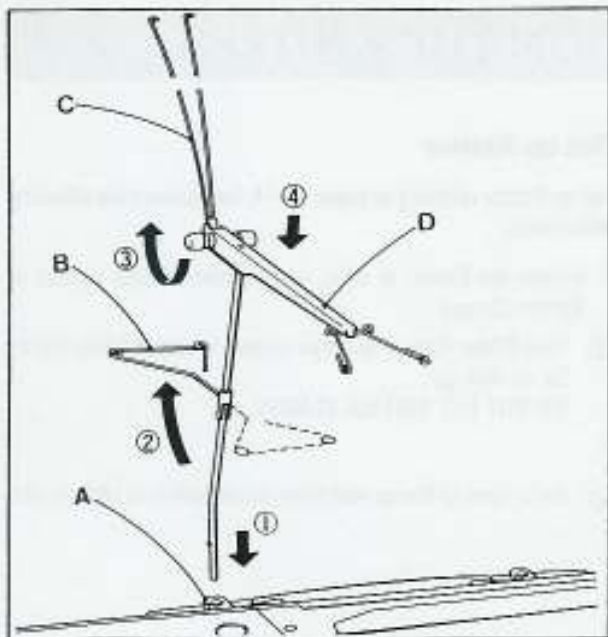

4. Assemble Auto-Tension and Yarn Rod as follows.

- ① Insert the bent end of Yarn Rod into the bracket socket "A".
- ② Turn Tension Guide "B" to the back.
- ③ Turn Tension Springs "C" upwards till they click into position.
- ④ Place Auto-Tension "D" securely onto Yarn Rod.

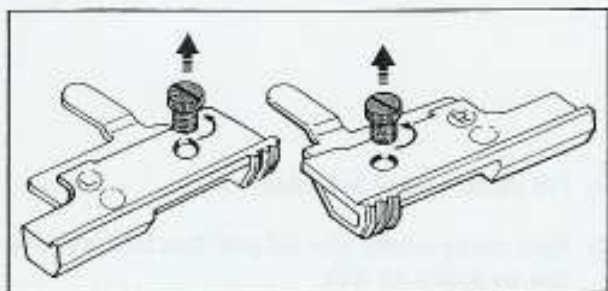

Attach Ribber Needle Bed to Knitter

Take out Auxiliary Pieces, marked "L" and "R", and insert them into left and right ends of Knitter Needle Bed respectively following instructions given below.

1. Remove Ribber Joiner Screws.

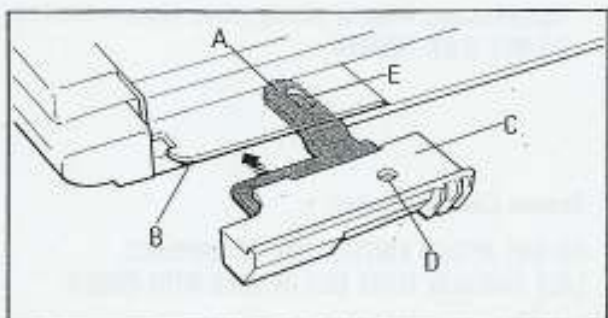

2. Insert finger "A" of Auxiliary Piece into underneath the front edge "B" of Knitter Bed and push backward until plastic part "C" of Auxiliary Piece covers front edge of Bed. (Finger "A" is under the needle bed, part "C" is on top of the needle bed.)

Ensure hole "D" of Auxiliary Piece corresponds with slot "E" on Bed.

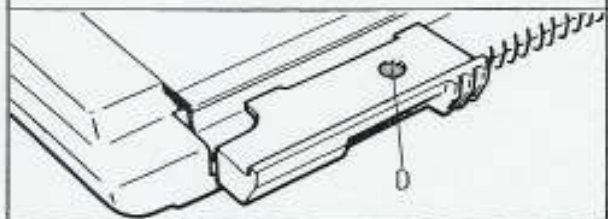

3. Insert Ribber Joiner Screws on left and right side into Auxiliary Pieces and fasten by 3—4 turns only.

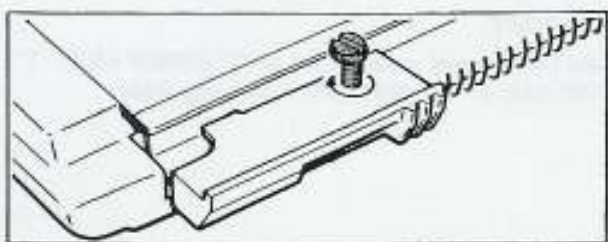

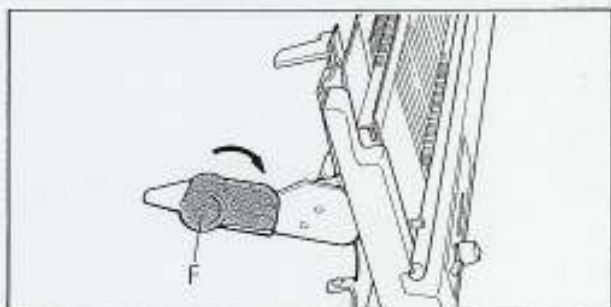
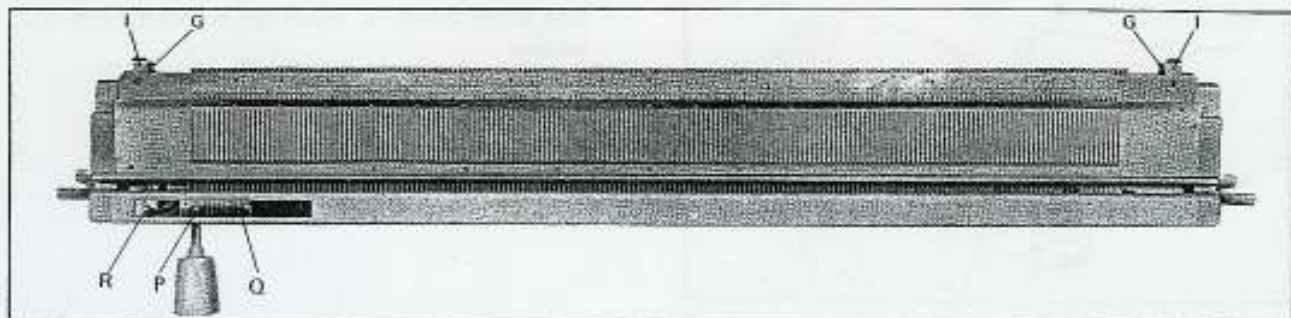

4. Bring both Push-up Cams "F" forward.

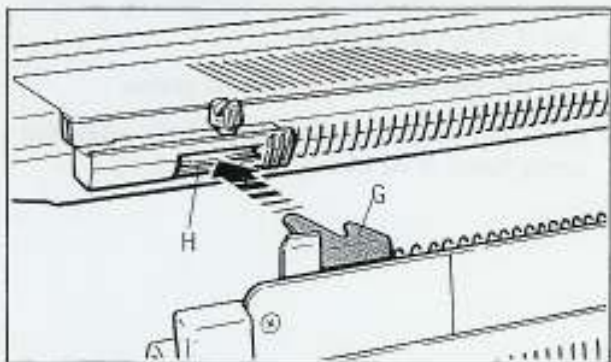

5. Hold Ribber with both hands and insert Ribber Joiners "G" on both sides into slots of Auxiliary Pieces "H".

Insert the right side first, then the left side.

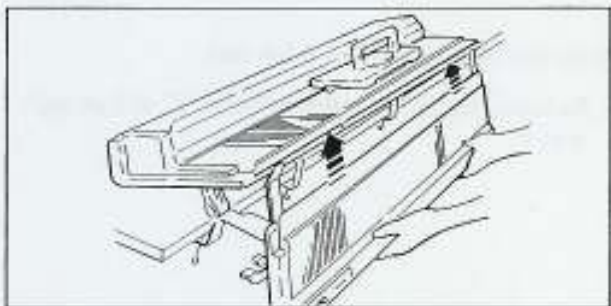

CHECK POINT

Ensure Ribber Needle Bed is at the "UP" position.

If not push the Bed with both hands as far up as it goes.

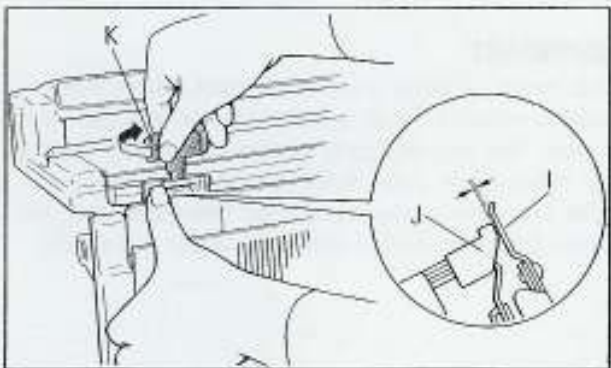

6. Push Ribber on both sides against Knitter until there is no gap between Ribber Stopper "I" and Auxiliary Piece "J".

Tighten both screws with Screw Driver "K".

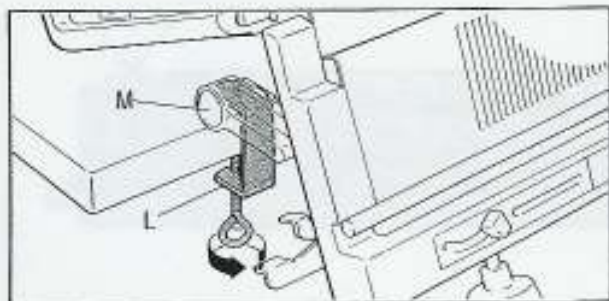

7. With Knitter Clamps "L", secure foot of Push-up Cams "M" on table.

DO NOT OVER TIGHTEN.

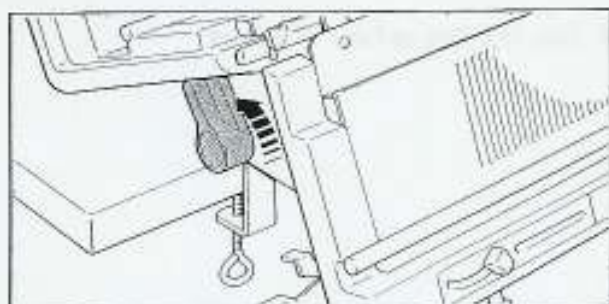

8. Raise both Push-up Cams in arrowed direction.

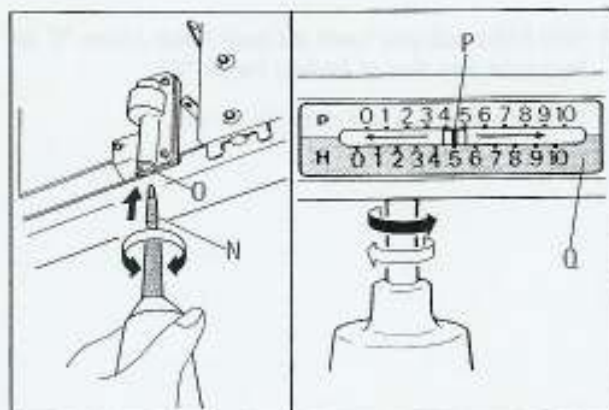

9. Insert Swing Handle shaft "N" into Swing Bearing "O" at the back of the left side of Ribber.

Push and twist handle until it clicks into position.

Ensure the Pointer "P" on Swing Indicator "Q" moves when turning Handle to the left and the right.

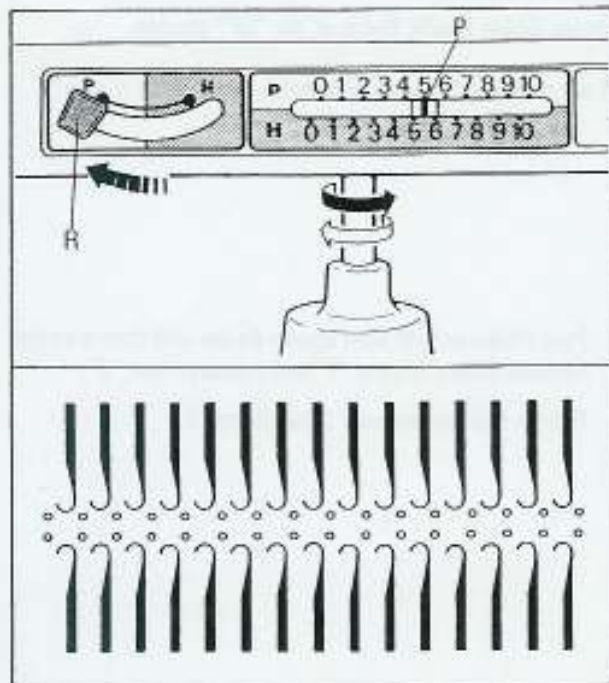

10. Set Half-Pitch Lever "R" to P (left side).

By turning Handle, set Indicator Pointer "P" at 5 on upper scale P.

IMPORTANT:

After joining the Ribber to the Knitter, check that the Ribber is correctly positioned. Push several needles on both beds to B position. They must be directly opposite each other. If they are not, loosen Ribber Joiner Screws and Clamps, and adjust the ribber to the correct position. Hold the Ribber in position, and tighten Screws and Clamps. Return the needles to A position.

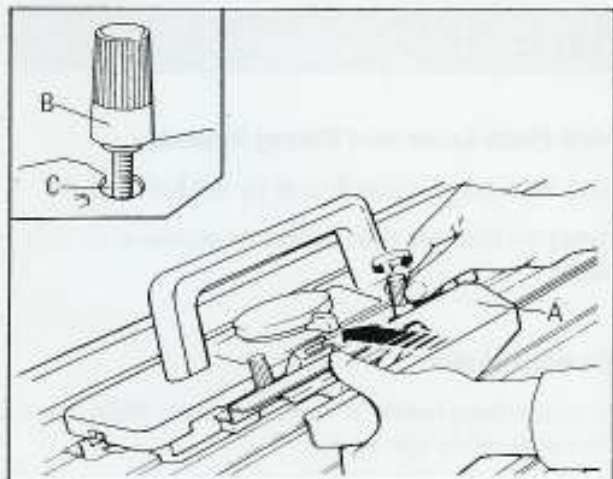

Place Ribber Arm on Knitter Carriage and Ribber Carriage on Ribber Needle Bed.

1. Loosen both Arm Nuts of Knitter Carriage.

Take Ribber Arm "A" and slide it under two Arm Nuts "B".

Push Ribber Arm as far back as it goes and tighten Arm Nuts firmly by turning them in arrow direction.

IMPORTANT:

Ensure that Arm Nuts "B" fit correctly into cutout "C" of Ribber Arm.

Do not attempt to attach Ribber Arm to Knitter Carriage when the Cam Lever is set to "F" or "L".

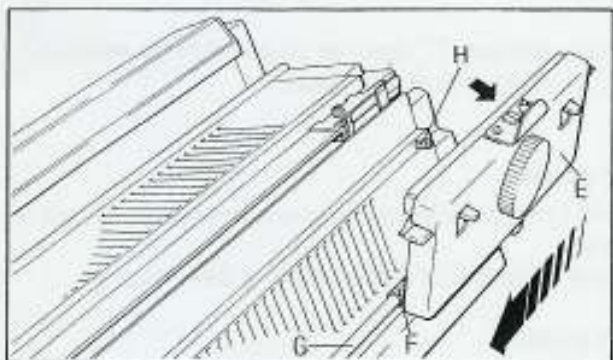

2. Take Ribber Carriage "E", and fit its pipe "F" on the Ribber Rail "G" from the right side.

Tilt the Ribber Carriage towards you to clear the Stopper Pin "H".

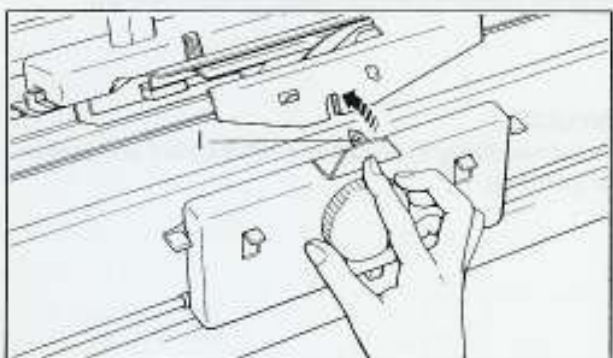

3. Move Carriage to Knitter Carriage.

Push Link Pin "I" into the slot of Arm until you hear a click.

CHECK POINT

Move Carriage a few times across Needle Bed to ensure Knitter/Ribber Carriage and Ribber Arm are assembled correctly.

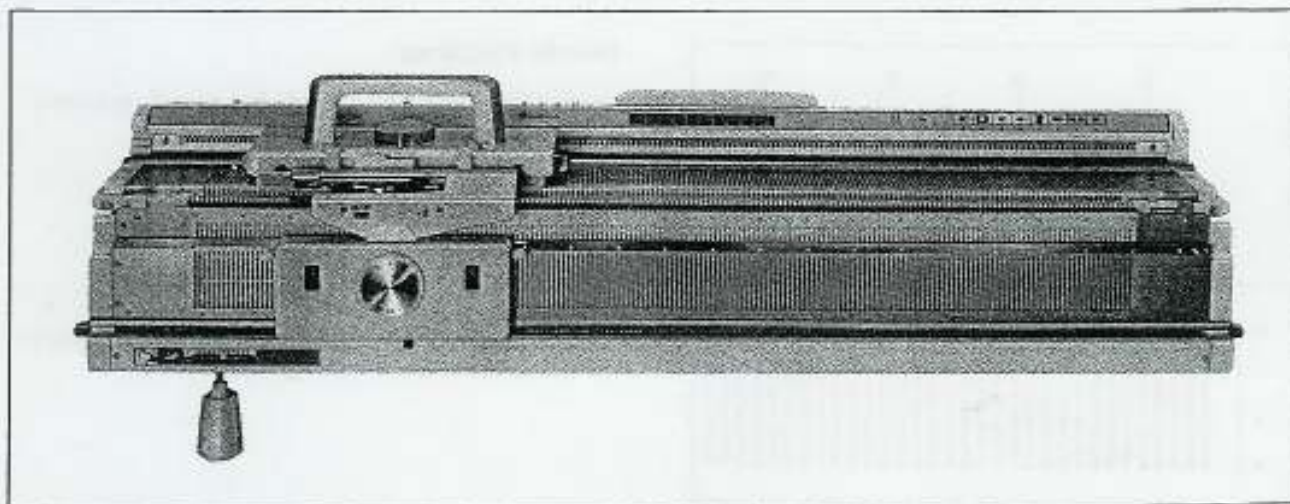

RIBBER NEEDLE BED



Half-Pitch Lever and Swing Indicator

There are two setting positions (P or H) for Half-Pitch Lever "A".

Moving the Half-Pitch Lever changes the position of the ribber needles.

Swing Handle

By rotating Swing Handle "B" to the right or left, Ribber Needle Bed can be moved right and left.

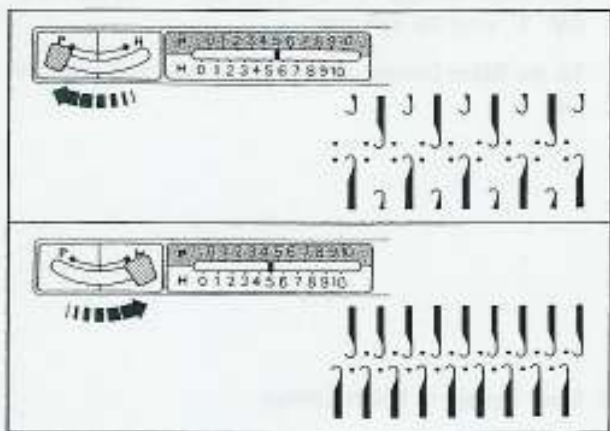

Swing Indicator "C" shows the position of Ribber needle on P scale (upper) or on H scale (lower).

P position

Half-Pitch Lever is set to P when every other needle selection is used.

Read the number on P scale (upper) of Swing Indicator.

H position

Half-Pitch Lever is set to H when every needle selection is used.

Read the number on H scale (lower) of Swing Indicator.

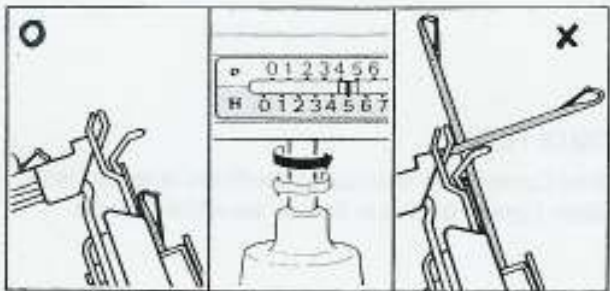

IMPORTANT:

Do not turn Swing Handle while needles are in C or D position on both beds.

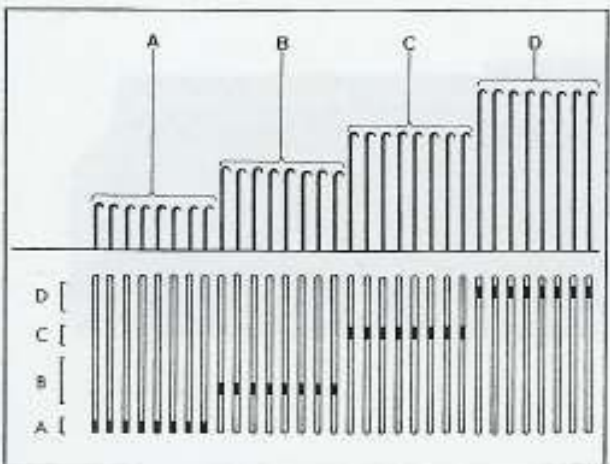

Needle Positions

On both left and right ends of Needle Bed, you will see markings A, B, C and D associated with brackets "]".

These four needle positions are used during knitting.

A — Non-working position

B — Working position

C — Needles in this position always operate.

D — Holding position

(Needles in this position are knitted back to B position when Russel Levers are at = position.)

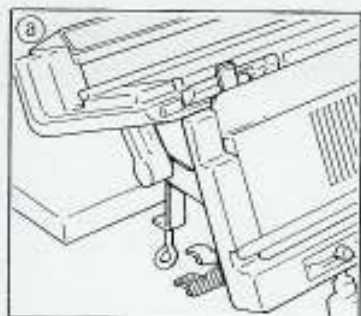

Drop Levers

On both left and right ends of Needle Bed you will find Drop Levers (marked red). Using these levers you can change position of Needle Bed.

- (a) Top position (knitting position)
This position is used for knitting all nb stitches.

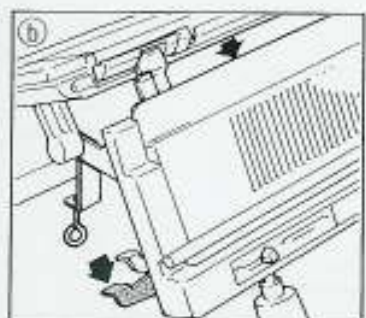

- (b) Middle position
Depress Drop Levers on both sides once, and Ribber Bed is lowered to its middle position.
This position is used when picking up stitches.

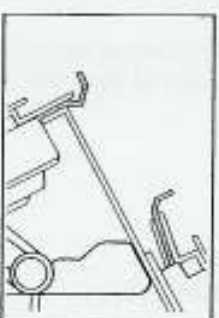
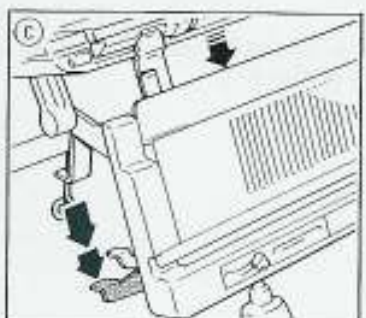

- (c) Lowest position
Depress Drop Levers twice, and Ribber Bed is lowered to its lowest position.
This position is used when knitting only on Knitter.

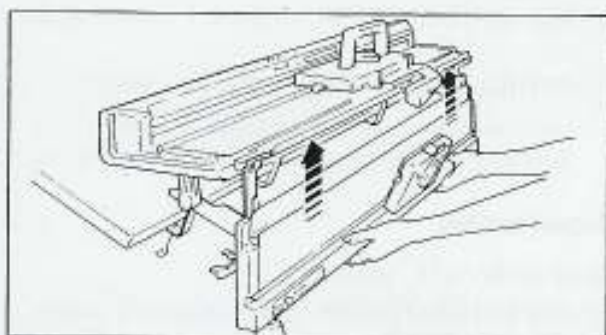

To restore Ribber Bed to its top position, push up both ends of the Ribber simultaneously.



Pile Levers

Above Drop Levers, Pile Levers (marked blue) are located, and are used to broaden the distance between Knitter and Ribber.

- (a) For normal knitting ensure both Pile Levers are in upper position.
(b) For pile knitting ensure both Pile Levers are in lower position.

To restore the levers to upper position, raise them up with your fingers.

RIBBER CARRIAGE

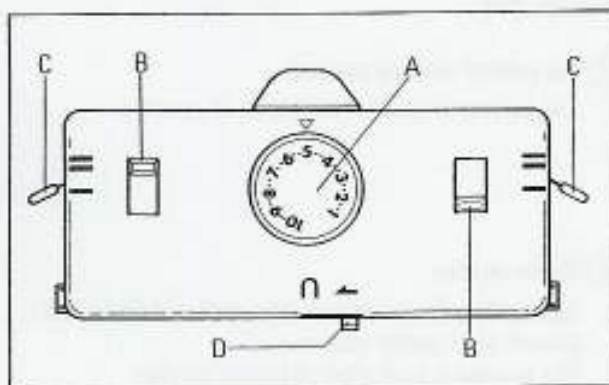

- A — Stitch Dial
- B — Set Levers
- C — Russel Levers
- D — Pick Knob

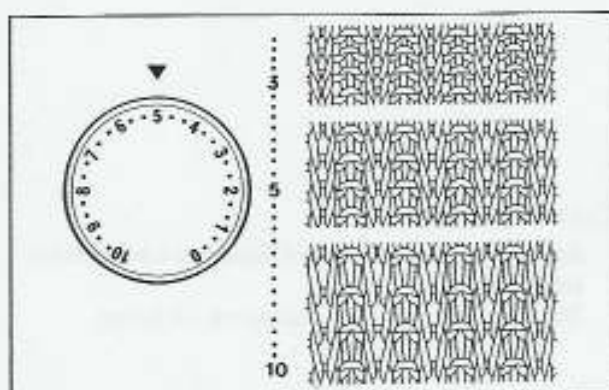

Stitch Dial

Controls stitch size.

Set a selected number or dot to ▼ mark.

The larger the number the bigger the stitch, and the smaller the number the smaller the stitch.

According to the thickness of yarn to be used, select proper setting of Stitch Dial. (Refer to page 61.)

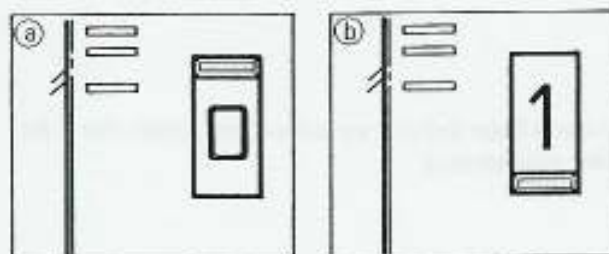

Set Levers

Control needles in "B" position.

- (a) NON KNITTING POSITION, needles in B position will not knit.
- (b) KNITTING POSITION, needles in B position will knit.
Left lever works when moving Carriage to the left.
Right lever works when moving Carriage to the right.

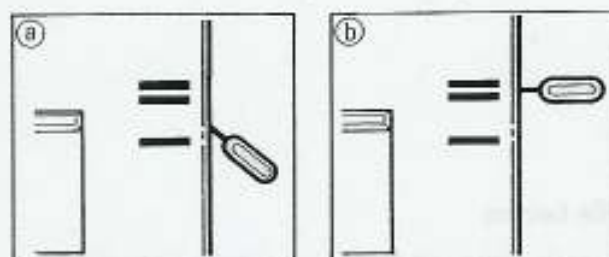

Russel Levers

Control needles in "D" position.

- (a) NON KNITTING POSITION, needles remain in D position.
- (b) KNITTING POSITION, needles in D position will knit back to B position.
Left lever works when moving Carriage to the left.
Right lever works when moving Carriage to the right.

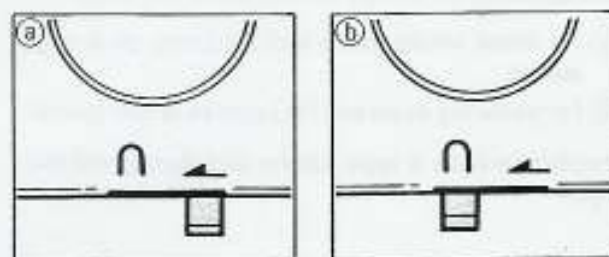

Pick Knob

Works on the needles in B position when Set Lever on the leading side is set at

- (a) NON KNITTING POSITION, yarn is not knitted.
- (b) PICK POSITION, yarn is laid into needle hook only.

RIBBER ARM

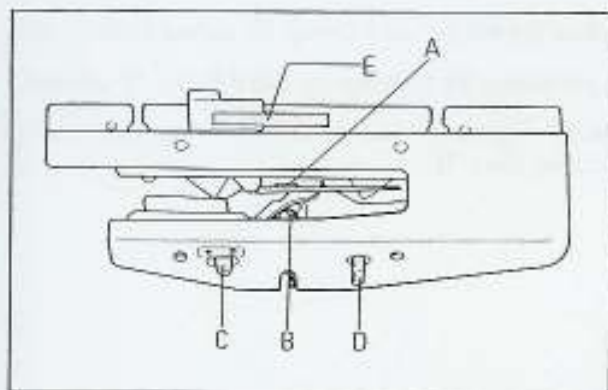

- A — Main Yarn Feeder
- B — Auxiliary Yarn Feeder
- C — Auxiliary Yarn Feeder Lever
- D — Link Knob
- E — Driving Lever

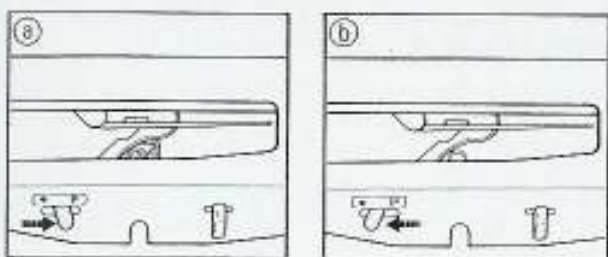

Auxiliary Yarn Feeder Lever

- (a) For pile knitting set this lever to P mark.
- (b) For ordinary knitting, set this lever to ● mark.

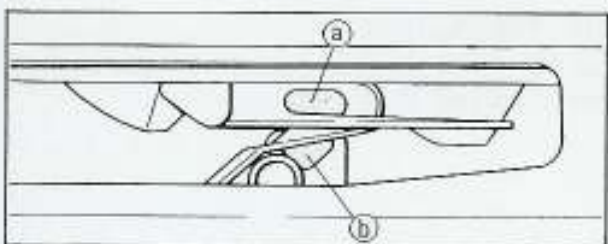

Yarn Feeders

- (a) Main Yarn Feeder, used for ordinary rib stitches.
- (b) Auxiliary Yarn Feeder, used with Main Yarn Feeder in pile knitting only.

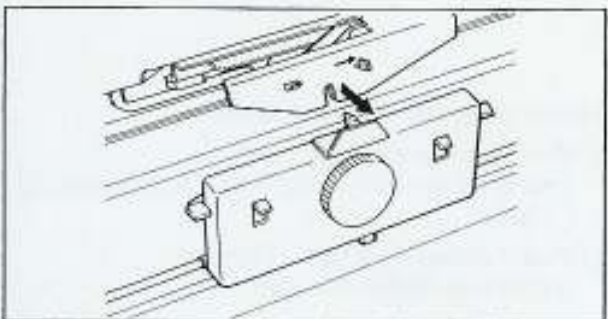

Link Knob

Push the Knob to the right to disconnect Ribber C carriage.

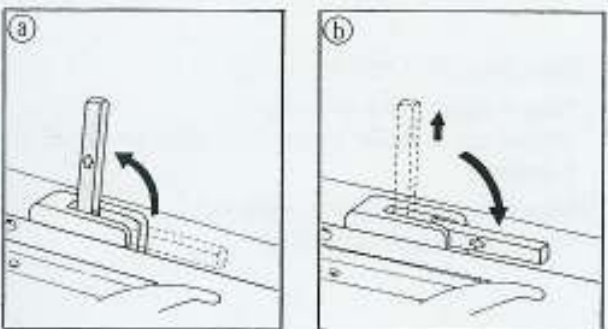

Driving Lever

- (a) When knitting with Yarn Changer, raise this lever.
- (b) When knitting without Yarn Changer, keep this lever in the rest position.

To put lever in the rest position, lift it slightly, then lay it down.

P CARRIAGE

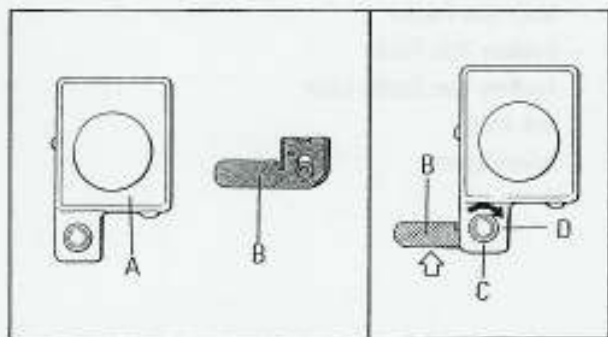

In drive lace knitting, use P Carriage "A" without P Presser "B".

In pile knitting, use P Carriage "A" with P Presser "B" attached.

Place P Presser "B" underneath Arm "C" and secure with fastening screw "D".

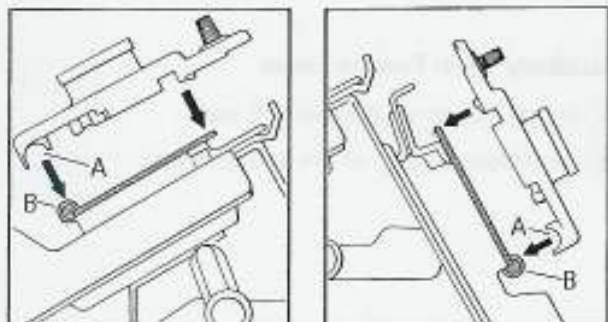

WITHOUT P PRESSER

Place P Carriage straight onto Knitter or Ribber Needle Bed ensuring rail guide "A" fits correctly on rail "B".

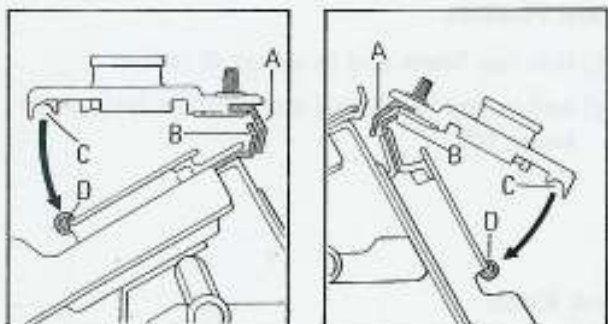

WITH P PRESSER ATTACHED

Place P Presser "A" over Sinker Posts "B" first, then place rail guide "C" onto rail "D".

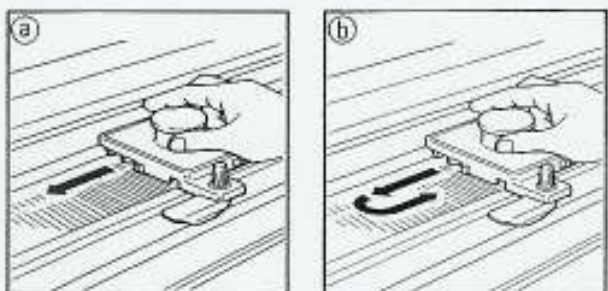

On Knitter always start from the right side.

- (a) Move P Carriage once (right→left).
Stitches will be behind latches and needles are aligned in C position.
- (b) Move P Carriage twice (right→left→right).
Stitches have slipped off needles.

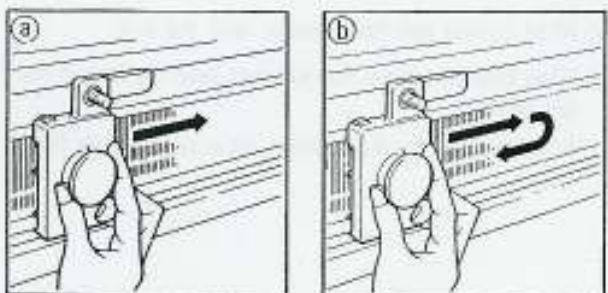

On Ribber always start from the left side.

- (a) Move P Carriage once (left→right).
Stitches will be behind latches and needles are aligned in C position.
- (b) Move P Carriage twice (left→right→left).
Stitches have slipped off needles.

YARN AND STITCH DIALS



Stitch Dial setting will vary according to thickness of yarn and type of knitting.

For your reference, recommended numbers are shown below.

Picture shows actual size of yarns.

Very thick yarns (⑥, ⑦) are not suitable for rib knitting.

The table below shows the recommended Stitch Dial settings for each type of yarn and type of knitting.

TYPE OF YARN		thin ① ②		light ③ ④		medium ④ ⑤		thick ⑤ ⑥	
TENSION DIAL		7		5-7		3-5		1-3	
STITCH DIAL									
CAST ON (every needle selection)	initial row	0	0	0	0	0	0	-	-
	subsequent rows	0	0	1	1	2	2	-	-
CAST ON (every other needle selection)	initial row	-	-	0	0	0	0	0	0
	subsequent rows	-	-	0	0	0	0	2	2
DOUBLE RIB		0-1		1-2		3-4		-	
K1.P1. RIB		-		0-1		2-3		6-7	
K2.P2. RIB		-		2-3		3-4		6-7	
WIDE RIB *		-		1-2	3-4	3-4	5-6	5-6	7-8
TUBULAR KNITTING *		2-3	4-5	4-5	6-7	5-6	7-8	-	

* Set the ribber Stitch Dial two full numbers higher than that of the knitter.

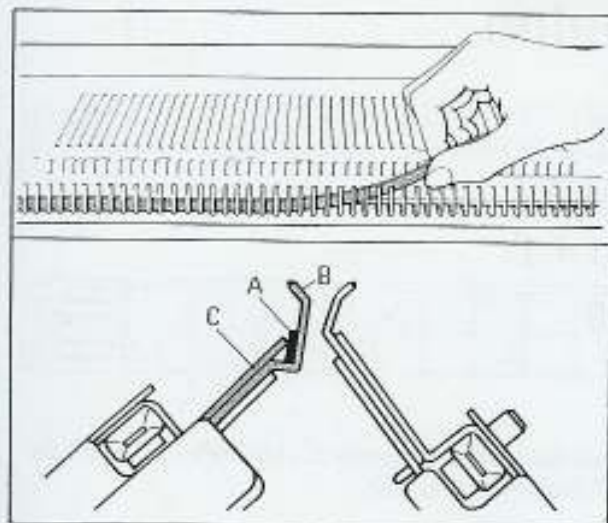

IMPORTANT:

When knitting with thin or light yarns or in tuck ribs with Pattern Card, use Close Knit Bar.

Before arranging needles, place Close Knit Bar "A" between Sinker Posts "B" and front edge "C" of Knitter Needle Bed.

OPERATION TABLE

For cast on and main knitting, Operation Table shown below gives settings and operation of machine.

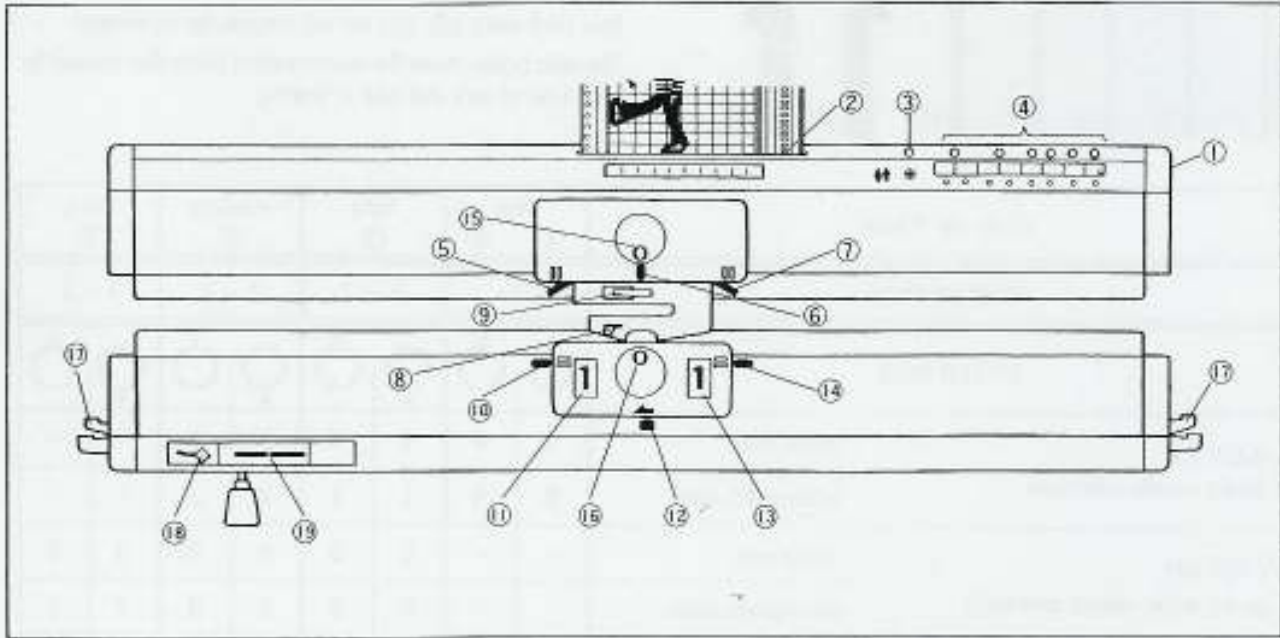





	①	②	③	④	⑤	⑥	⑦	⑧	⑨	⑩	⑪	⑫	⑬	⑭	⑮	⑯	⑰	⑱	⑳		
①	I		⊙		II	O	II	●	≡	=	□	←	□	=	0	0	↑	H	5		
2																			→		
3																					
4					C					0					0	0				≡→ 3	
5																					
②	1					O				□					3	3				5	≡→ 2
	2																			4	≡→ 2



If the diagram shown is given beside the needle arrangement diagram in the Operation Table, set the Point Cams and Needle-1 Cam in the same step.











CAST-ON	①	1	Set machine controls for the initial row.
		2	Arrange needles for knitting the initial row. (Set the Point Cams and Needle-1 Cam when the Pattern Card is in use.)
		3	Suspend Cast-on Comb with Weights.
		4	Change machine controls for knitting subsequent 3 rows.
CHANGES FOR MAIN KNITTING		5	Rearrange needles for main knitting by transferring stitches. (Not necessary if needle arrangement for main knitting is the same as for cast-on.)
MAIN KNITTING	②		Re-set machine controls for working main knitting. Follow the sequence 1, 2.....and repeat the same.

	①	ON-OFF Switch	 - Turn ON the machine.
PATTERN CONTROLS	②	Pattern Card	 - Set the Pattern Card.
	③	Inspection Button	⊙ - Light is ON. ⊙ - Light is OFF.
	④	Pattern Controls	 Set the pattern controls (Pattern Width, Card Buttons and Pattern Buttons) as instructed.
	⑤	Russel Lever (left)	*
KNITTER CARRIAGE	⑥	Cam Lever	Q — STOCKINET T — TUCK E — ENGLISH RIB C — CIRCULAR S — SLIP Never set to F (FAIR ISLE), L (PUNCH LACE) and W (WEAVING) while the ribber arm is used.
	⑦	Russel Lever (right)	*
	⑧	Auxiliary Yam Feeder Lever	
RIBBER ARM	⑨	Driving Lever	 - resting position  - working position
	⑩	Russel Lever (left)	*
RIBBER CARRIAGE	⑪	Set Lever (left)	
	⑫	Pick Knob	
	⑬	Set Lever (right)	
	⑭	Russel Lever (right)	*
	⑮	Knitter Stitch Dial	} Refer to table on next page.
⑯	Ribber Stitch Dial		
RIBBER NEEDLE BED	⑰	Pile Levers (left & right)	↑ upper position ↓ lower position
	⑱	Half-Pitch Lever	
	⑲	Swing Indicator	
	⑳	Arrow mark indicates knitting direction of Carriage and number shows the number of rows to be knitted.	

*Always set Russel Levers at II and = except for working partial knitting.

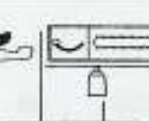
CAST-ON AND KNITTING

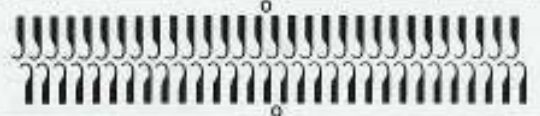
Following the Operation Table, cast-on and knit Double Rib without using the Pattern Card.
For the nb stitches without the Pattern Card, it is not necessary to switch the machine on.

								
①	1		O	●	=	0	0	↑ H 5
2								→
3								
4			C		0		1 1	→→→
②			O		0		2 2	→→→

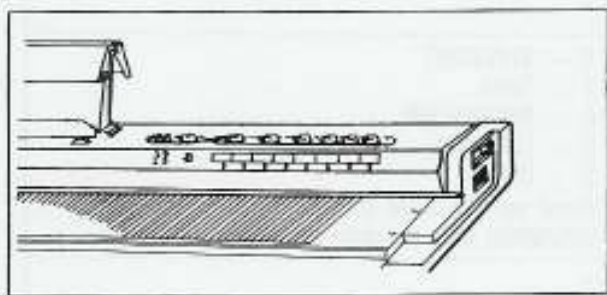

CAST-ON

- ① —] Set machine controls for the initial row.

ON-OFF Switch..... OFF

PATTERN CONTROLS

No Buttons are operated.

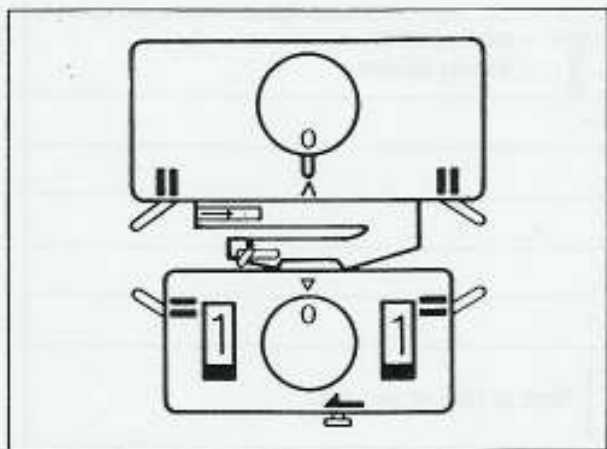

STANDARD CARRIAGE

Russel Levers (left & right)..... ||
Cam Lever..... "0" (STOCKINET)

RIBBER ARM

Auxiliary Yarn Feeder Lever..... ●
Driving Lever..... resting position

RIBBER CARRIAGE

Russel Levers (left & right)..... =
Set Levers (left & right)..... 0
Pick Knob..... ↑

STITCH DIALS (Knitter & Ribber)..... 0

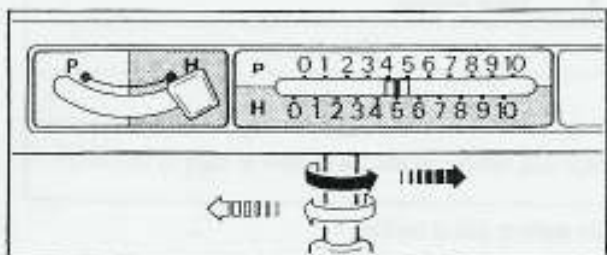

RIBBER NEEDLE BED

Pile Levers (left & right)..... upper position
Half-Pitch Lever..... H
Swing Indicator..... 5

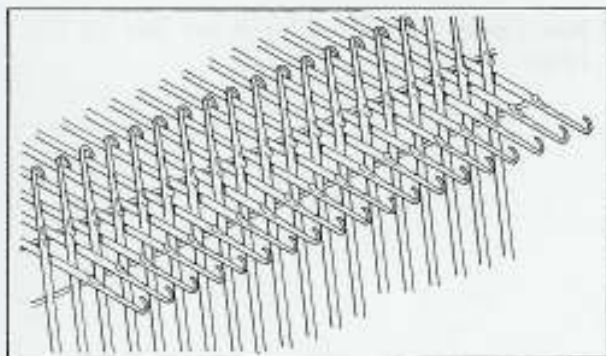

● — 2 Arrange needles for knitting the initial row.

1. Arrange needles of both beds for cast-on.
 - (1) On both of Knitter and Ribber Beds, push 25 needles on each side of centre(0) up to D position.

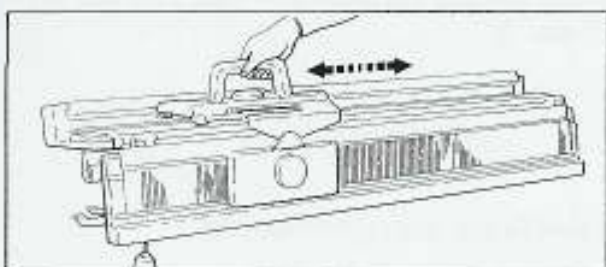

- (2) Move Carriage 2 — 3 times carefully across needles in D position and leave it at right side. (Needles in D position will be aligned in B position on both beds.)

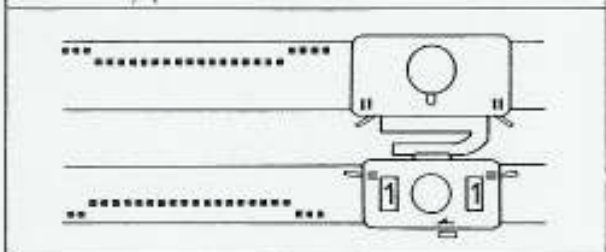

2. Thread yarn into Yarn Feeder.

- (1) After threading yarn through Auto-Tension, make a loop at the end of yarn and hold it at the left side of both beds.
- (2) Insert Hook Tool "A" from underneath, catch yarn end, and pull it down.

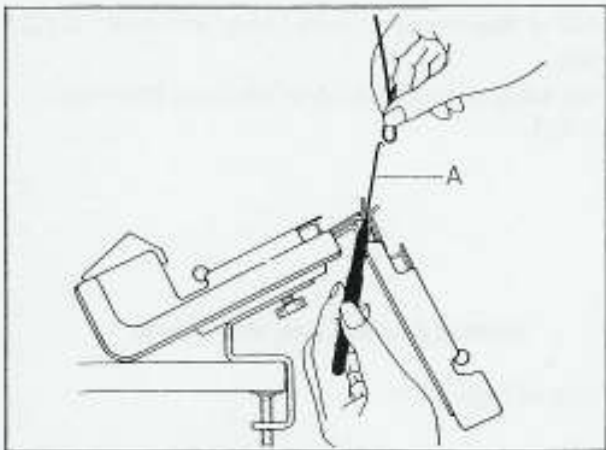

(3) Tie yarn end to Clamp.

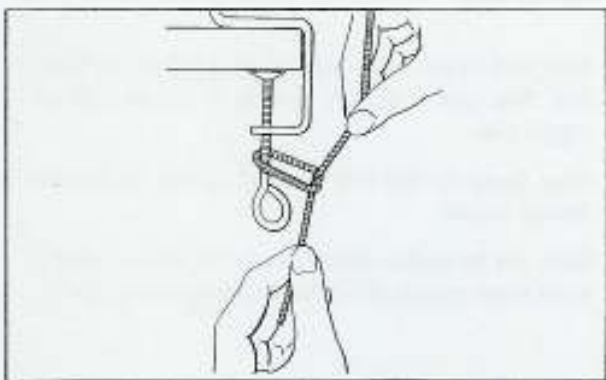

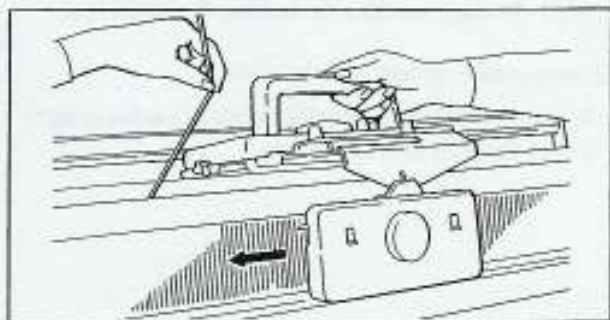

(4) Move Carriage from right to left till yarn goes into Yarn Feeder.

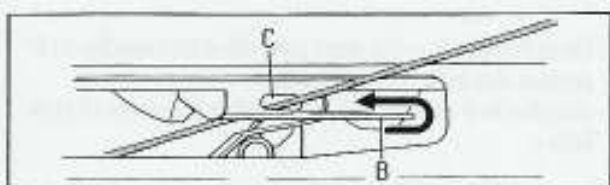

(5) Guide yarn along Yarn Guide "B" to thread it into Main Yarn Feeder "C".

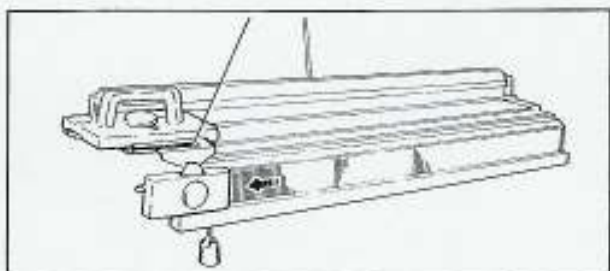

(6) Move Carriage to left end of Needle Bed.

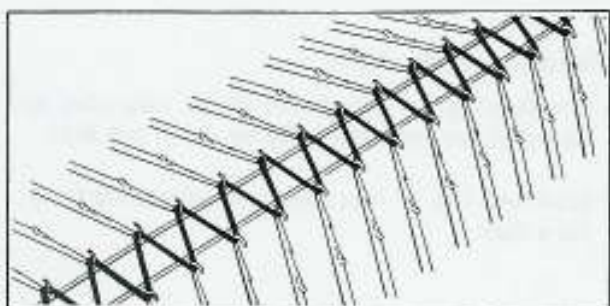

3. Knit the initial row.

Take up slack of yarn and move Carriage from the left to the right.

Yarn will be hooked alternately on Knitter and Ribber needles in zigzag.

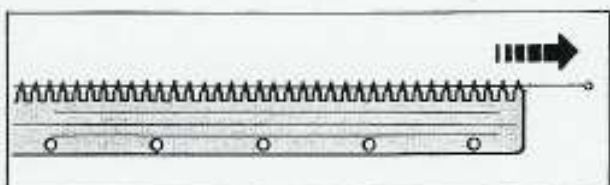

① — 3 Suspend Cast-on Comb with Weights.

1. Suspend Cast-on Comb.

(1) Take out short Cast-on Comb (100-needle) and remove wire from its teeth.

(2) From underneath, insert Comb between Knitter and Ribber Bed, then push it carefully upwards until teeth clear zig-zagged yarn.

Hang Comb so that it is balanced horizontally between working needles.

Make sure the comb is centred on yarn, i.e. an equal length of comb shows at each side of the needles in working position.

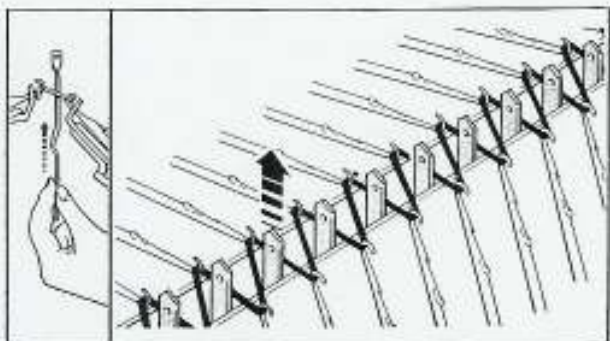

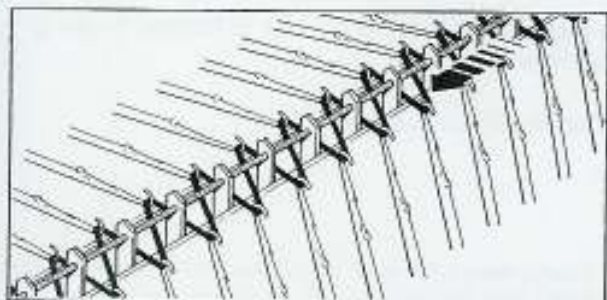

(3) Insert Wire through holes of Cast-on Comb teeth.

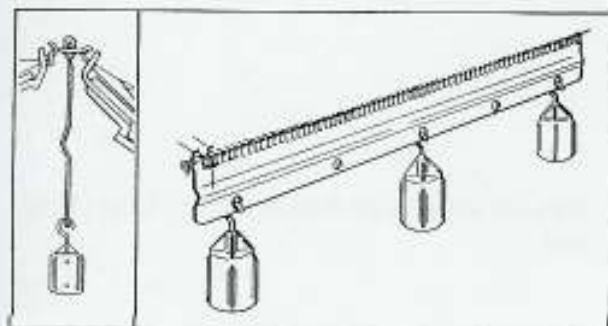

2. Hook Weights.

Use two Ribber Weights (large) and hook them onto left and right sides of Cast-on Comb.

For your reference use up to 80 needles 2 Weights
 120 needles 3 Weights
 160 needles 4 Weights
 200 needles 5 Weights

Hook Weights at even intervals.

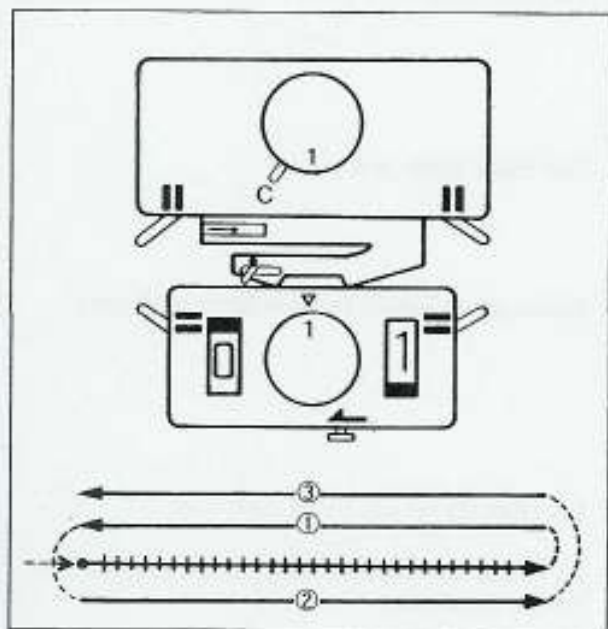

① — 4 Change machine controls for knitting subsequent 3 rows.

Change Carriage settings.

Cam Lever..... C (CIRCULAR)
 Set Lever (left)..... **0**
 Stitch Dials (Knitter & Ribber)..... 1

Knit 3 rows.

CAST-ON IS COMPLETED.

Release the yarn end from the Clamp.

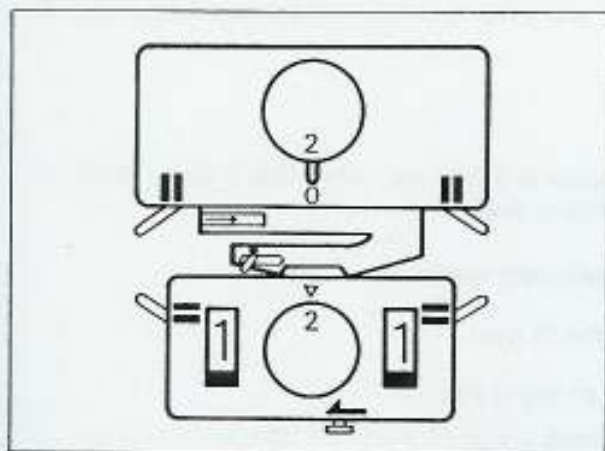

② Re-set machine controls for working main knitting.

(Needle arrangement for main knitting is the same as for cast-on.)

1. Change Carriage setting.

Cam Lever..... 0 (STOCKINET)
 Set Lever (left)..... **1**
 Stitch Dials (Knitter & Ribber)..... 2
 Other setting unchanged

2. Knit 20 rows by moving Carriage smoothly across Needle Bed.

DOUBLE RIB IS KNITTED.

Continue on next page for transferring stitches to work K1.P1. rib.

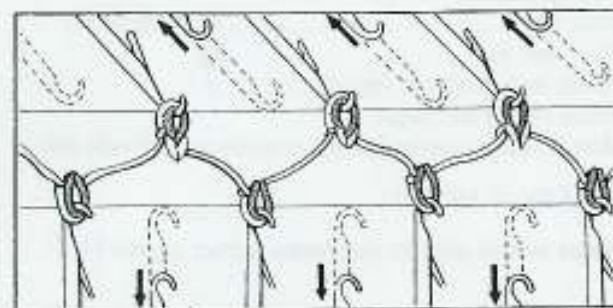
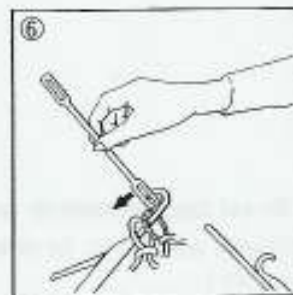
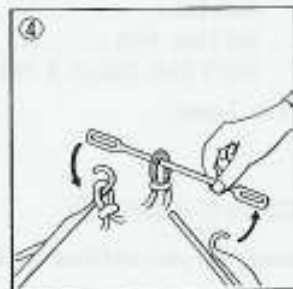
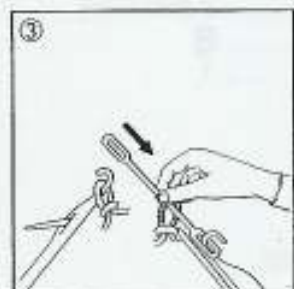
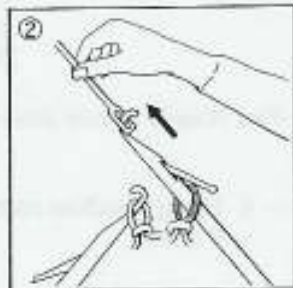
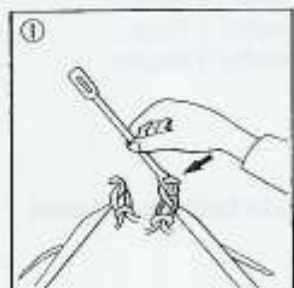
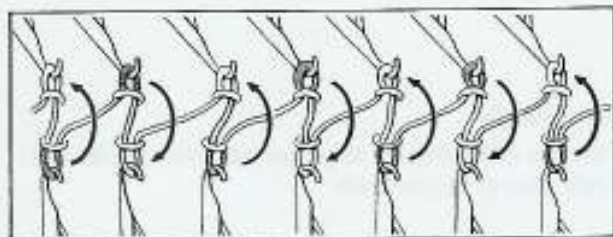
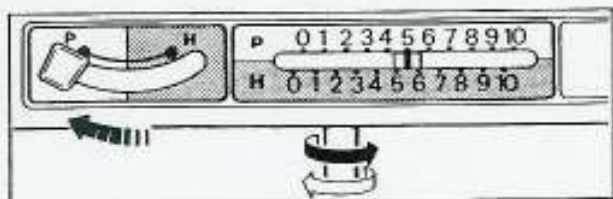

For practice, continue to knit in K1, P1. nb following the instructions below.

1. Set the Half Pitch Lever to "P".
2. Transfer every other stitch from Knitter onto Ribber and from Ribber onto Knitter alternately to rearrange the needles for K1, P1. RIB using Double-eye Transfer Tool as follows.

① Place eye of Double-eye Transfer Tool into Ribber needle hook.

② Pull Ribber needle to D position.

③ Push Ribber Needle to A position.

④ Remove eye of Transfer Tool from Ribber needle hook.

⑤ Place opposite eye into Knitter needle hook.

⑥ Tilt Transfer Tool until stitch slides into Knitter needle hook. Remove Transfer Tool.

Push needle in B position slightly towards A position to ensure that transferred stitch lies correctly in needle hook.

Continue to transfer every other stitch till all the needles are aligned as shown.

Ensure empty needles are in A position.

3. Knit 20 rows.

K1, P1. RIB IS KNITTED

Referring to page 70, remove the fabric from the machine.

CAST-ON FOR TIGHTER EDGE

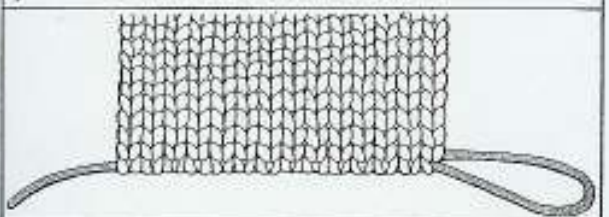
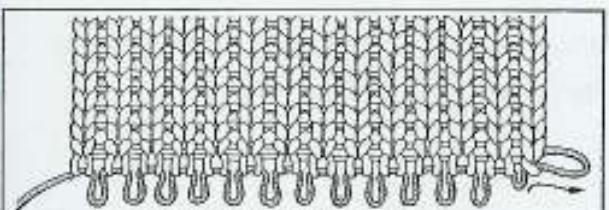
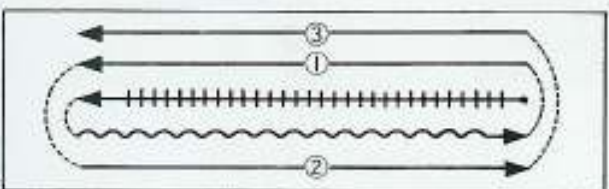
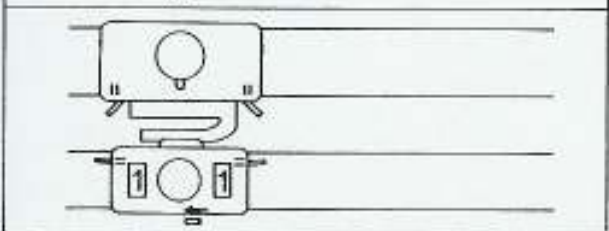
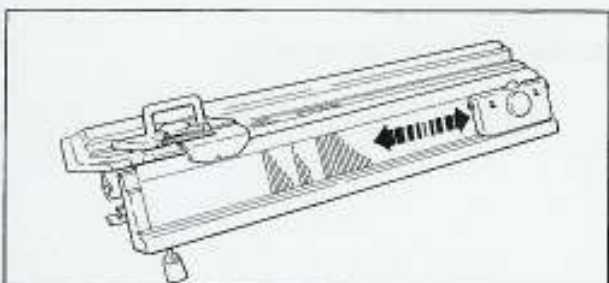
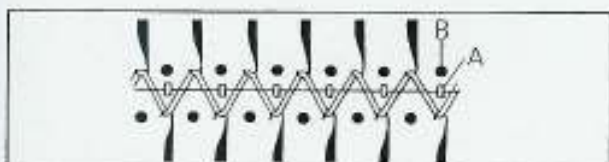
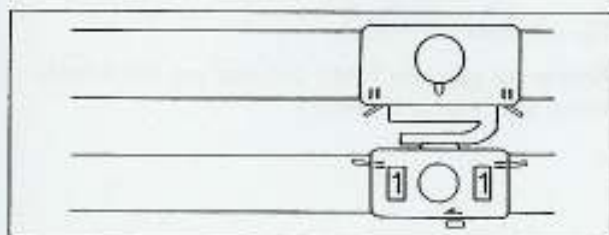

To make the cast-on edge of the fabric tighter, when knitting with thin yarn, set the Carriages as instructed in the operation table, but operate them following the procedure given below—

- ❶ — 1 Set machine controls for the initial row and have Carriage on the right side.
- ❷ — 2 Arrange needles, and knit the initial row from the right to the left.
- ❸ — 3 Suspend Cast-on Comb with Weights.

Insert Cast-on Comb so that its teeth "A" face Knitter Sinker Posts "B" as illustrated.

- Disconnect Ribber Carriage and move it twice across the needles to drop stitches on Ribber needles.

If Cast-on Comb is suspended incorrectly, it will drop onto the floor.

- Connect Ribber Carriage and knit one row with same Carriage settings.

- ❹ — 4 As required in operation table, knit subsequent 3 rows. CAST-ON FOR TIGHTER EDGE IS COMPLETED.

When the garment has been completed, pull the yarn of the initial row from the opposite side to the yarn end. This will tighten the cast-on edge.

After pressing, pull out the yarn completely in the same direction as above.

REMOVE THE FABRIC FROM THE MACHINE

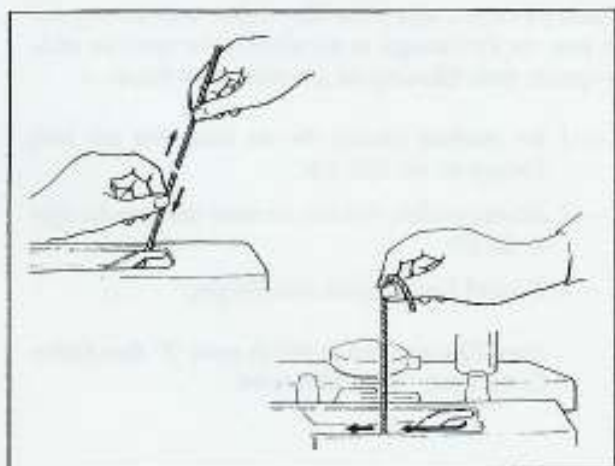

1. Cut yarn above Yarn Feeder.

Remove the yarn from Feeder and drop yarn end between Knitter and Ribber sinker posts.

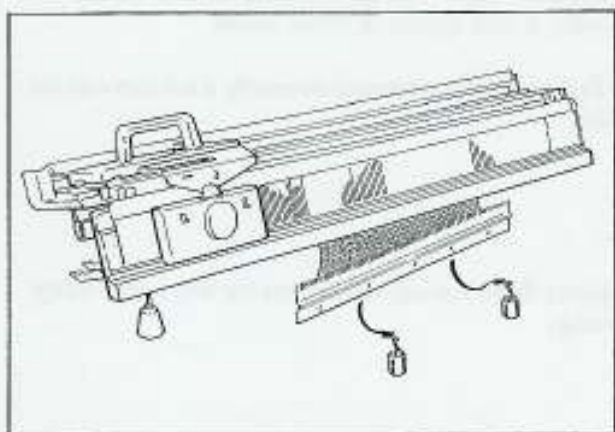

2. Remove Weights from Cast-on Comb.

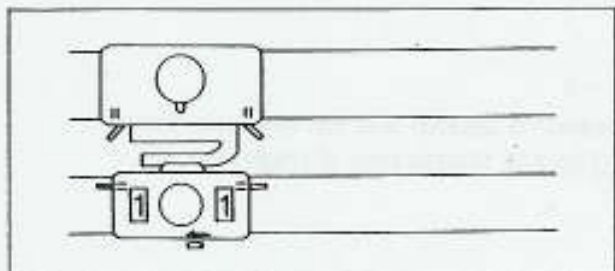

3. Change Carriage settings as follows.

Cam Lever..... 0 (STOCKINET)
Set Levers..... I
Russel Levers..... II

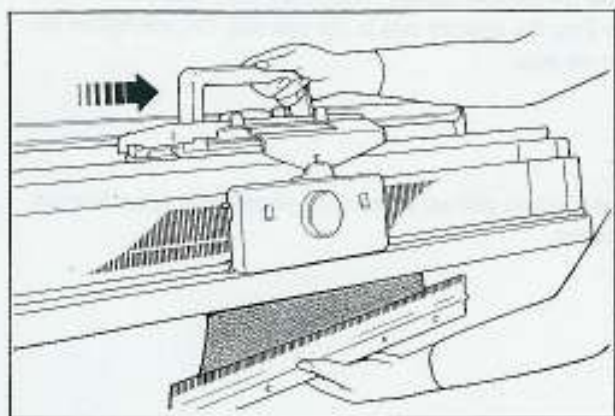

4. Holding Cast-on Comb, move Carriage once across needles.
The stitches are released from needles.

VARIOUS RIB STITCHES

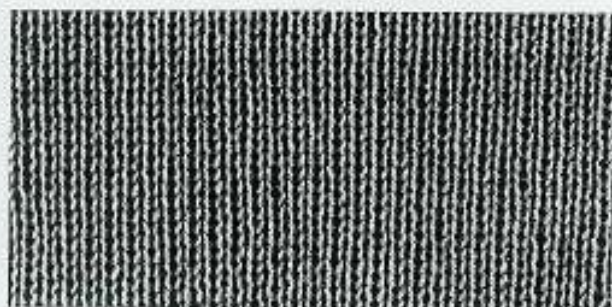

DOUBLE RIB

Use every needle of Knitter and Ribber.

The sample is knitted using thin yarn.

Use Close Knit Bar (refer to page 61).

1	I		⊙	O	●	=	☐	←	☐	=	0	0	↑	H	5			
2															→			
3																		
4				C			☐											≡) 3
2	1			O			☐											≡) 3

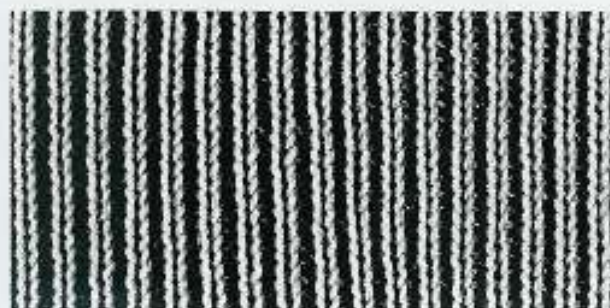

K1.P1. RIB

Use every other needle of Knitter and Ribber.

The sample is knitted using medium yarn.

1	I		⊙	O	●	=	☐	←	☐	=	0	0	↑	P	5			
2															→			
3																		
4				C			☐											≡) 3
2				O			☐				2	2						≡) 3

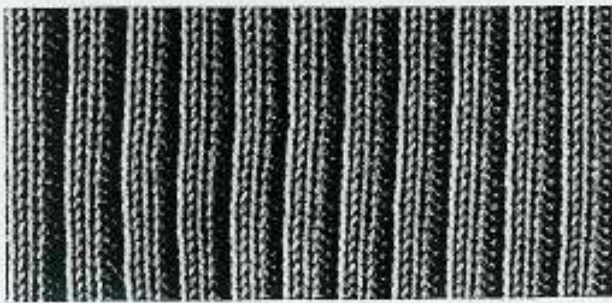

K2.P2. RIB

Two methods for K2.P2. rib are introduced below.—
 One is for using medium yarn (Operation Table "A") and the other
 is for thick yarn (Operation Table "B").

A

① 1		⊙	O	●	≡	≡	←	≡	0	0	↑	H	5					
2																	→	
3																		
4			C			0												≡≡≡ 3
② 1			O			0			4	4			6					≡≡≡

B

① 1		⊙	O	●	≡	≡	←	≡	0	0	↑	H	5					
2																	→	
3																		
4			C			0												≡≡≡ 3
② 1			O			0			7	7		P	6					≡≡≡

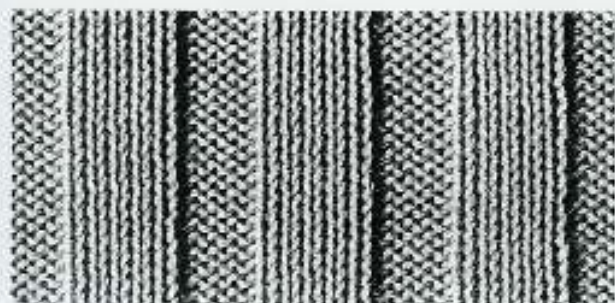

WIDE RIB

This is the rib with more than K3, P3, stitches aligned alternately. (K5, P5, rib is shown as an example.)

Two methods for wide rib are introduced below.—
One is for using medium yarn (Operation Table "A") and the other is for thick yarn (Operation Table "B").

A

①	1		⊙	O	●	≡	□	←	□	=	0	0	↑	H	5				
2																			→
3																			
4					C						0				2	2			≡≡≡ 3
5																			
②					O										4	6			≡≡

B

①	1		⊙	O	●	≡	□	←	□	=	0	0	↑	P	5				
2																			→
3																			
4					C						0				2	2			≡≡≡ 3
5																			
②					O										6	8			≡≡

* One end needle on the knitter and on the Ribber must be in B position
This may change the needle arrangement, but it is essential.

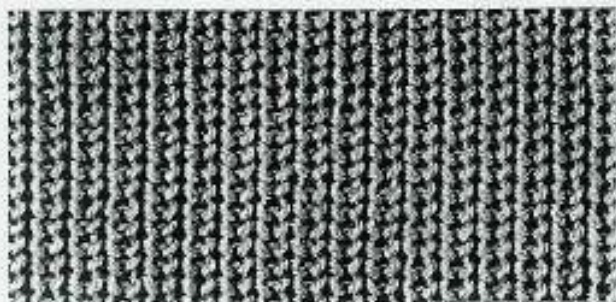

ENGLISH RIB

This rib has a tuck pattern on one side of the knitting. It can be knitted on a K1.P1. rib, or in double rib.

The sample is knitted in K1.P1. rib using medium yarn.

①	1		⊙	O	●	⇒	=	□	←	□	=	0	0	↑	P	5	
	2															→	
	3																
	4			C				0					2				≡≡≡)3
②	1			E				1					4	4			≡≡≡)3

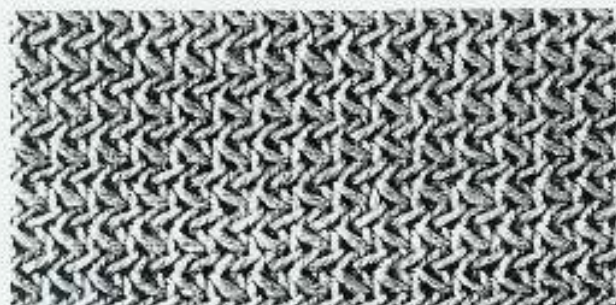

SWUNG ENGLISH RIB

This rib has a tuck pattern on one side of the knitting with a 2-pitch swing in K1.P1. rib or 1-pitch swing in double rib.

The sample is knitted in K1.P1. rib using medium yarn.

①	1		⊙	O	●	⇒	=	□	←	□	=	0	0	↑	P	5	
	2															→	
	3																
	4			C				0					2				≡≡≡)3
②	1			E				1					4	4			≡≡≡)2
	2															7	≡≡≡)2

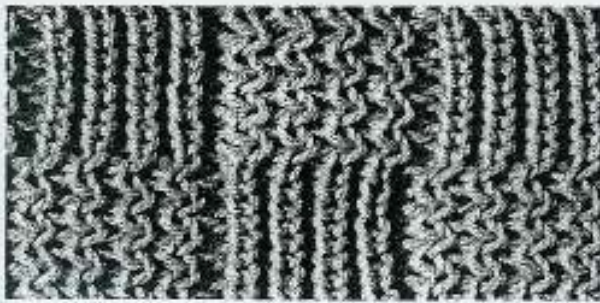

VARIATION OF ENGLISH RIB

This is a knitted fabric in combination of English Rib and Swung English Rib at the same time using the needle arrangement shown in the operation table.

The sample is knitted using medium yarn.

①	1		⊙	O	●	≡	⏏	⏏	≡	0	0	↑	H	5				
	2															→		
	3																	
	4				C				⏏					2			→→→ 3	
②	1				E				⏏					4	4			5 →→→ 16
																		6 →→→ 16
	2																	7 →→→ 16
																		6 →→→ 16

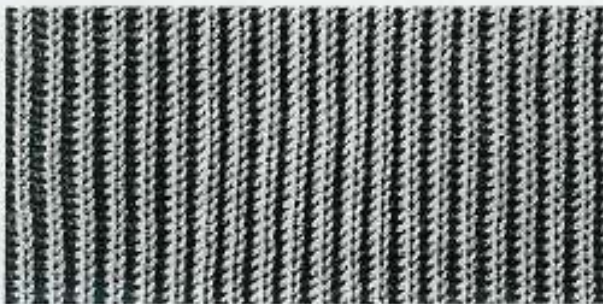

DOUBLE ENGLISH RIB

Tuck stitch is knitted on every row, on each side of the fabric alternately, in K1,P1. or double rib.

The sample is knitted in K1,P1. rib using medium yarn.

①	1		⊙	O	●	≡	⏏	⏏	≡	0	0	↑	P	5				
	2															→		
	3																	
	4				C				⏏					2			→→→ 3	
②					E				⏏					3	3			→→→

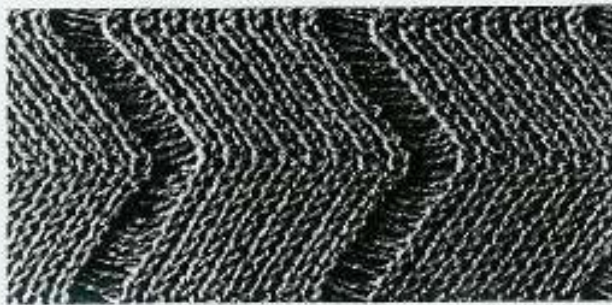

HERRINGBONE SWING

This fabric combines tuck stitch with swing operation of Ribber.
The sample is a variation of double rib using thin yarn.

①	1		⊙		○		●	=	1	←	1	=	0	0	↑	H	5																																
	2																					→																											
	3																																																
	4				C				0								2																									≡ 3							
	5																																																
②	1				E				1								2																									5	→						
																																												6	←	20			
	2																																														6	→	20
																																															5	←	

Note: Swing Ribber by 2 pitches for K1, P1. rib and 1 pitch for double rib.
Tuck one row on Knitter before you swing it back. Repeat and swing back and forth for the desired number of rows, then change the direction of the swing.

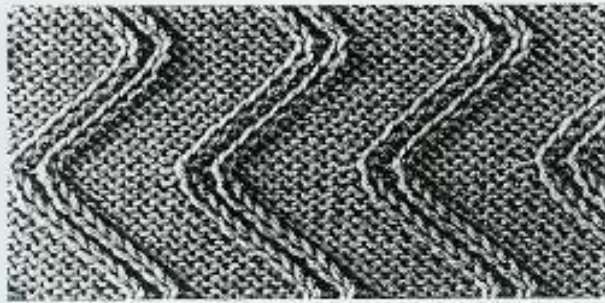

VARIATION SWING

While Knitter Carriage knits in stockinet, Ribber Carriage knits with selected needles making ridges. By swinging Ribber, these ridges make various swing patterns.

The sample is knitted using medium yarn.

①	1		⊙		○		●	—	=	1	←	1	=	0	0	↑	H	5		
2																				→
3																				
4					C					0				2	4					≡)3
5																				
②					0					1				6						5 →
																				4 ←
																				3 →
																				2 ←
																				1 →
																				0 ←
																				1 →
																				2 →
																				5 →
																				10 →
																				6 →
																				}*

* Knit swinging the Ribber by 1 pitch on every row to the extreme right, and then to the extreme left, to make zigzag pattern.

Push 1—5 end needles to 0 position before knitting the next row.

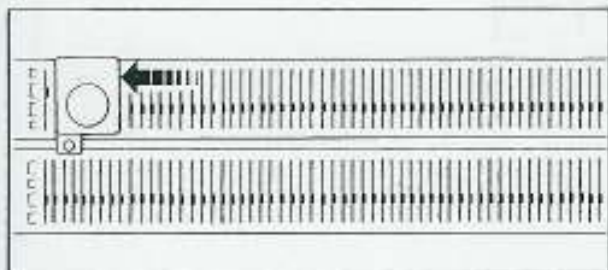

If stitches tend to float...

Knit pushing needles on Knitter to C position using P Carriage.

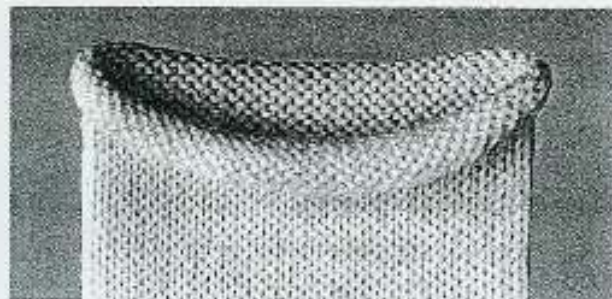

TUBULAR KNITTING

As you move Carriage back and forth, Knitter Carriage and Ribber Carriage knit alternately.

Set Ribber Stitch Dial to 2 numbers higher than Knitter Stitch Dial setting.

The sample is knitted using medium yarn.

①	1		⊙	O	●	⇒	=	□	↑	□	=	0 0	↑	H 5
	2													
	3													
②				C				0				6 8		P

* Knit with Ravel Cord, or waste yarn if using a lot of needles.

** When moving Carriage from left to right, knit bringing four to five needles at both ends of Ribber to D position, or push all needles on Ribber to C position using P Carriage (without P Presser).

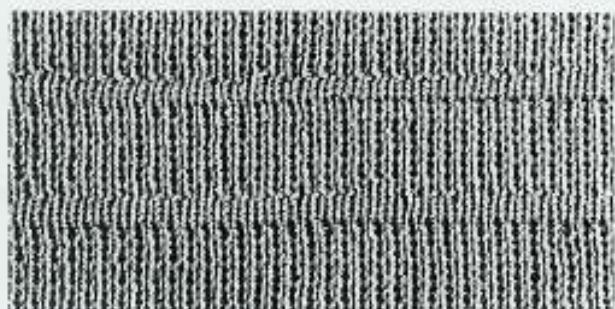

PIN TUCK

The sample is knitted with Pattern No. 11—(32) using thin yarn.

Do not use the Button 1 with its left light on and Button 3 and 6.

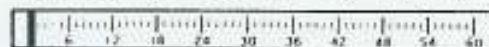
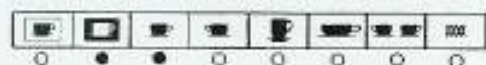

①	1	□	↓	⊙	O	●	⇒	=	□	↑	□	=	0 0	↑	H 5
	2														
	3														
	4			C				0				1 3		≡≡≡)3	
②			⊙	S				1				3 4		≡≡≡	

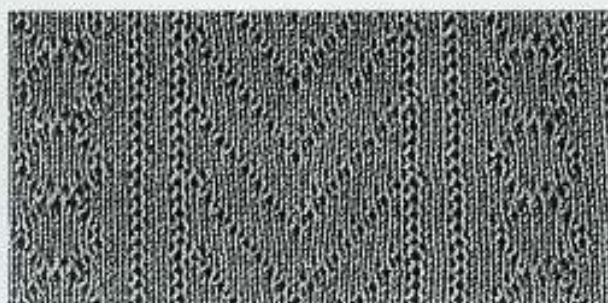

DRIVE LACE

The needle arrangement is the same as for the Double Rib, but on the knitter, the needles selected by the Pattern Card are fed with the yarn, and those stitches are released to form bigger loops, while on the Ribber all the needles knit every row.

Light yarn is suitable for this type of knitting.

The sample is knitted with the Pattern No.12—(35).

NOTE: If Drive Lace knitting follows an other pattern knitting, turn OFF the machine to clear the old memory before setting the machine for "DRIVE LACE".

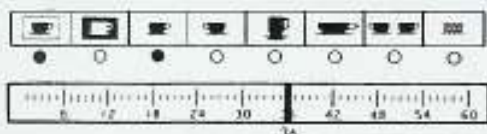

--	--	--	--	--	--	--	--	--	--	--	--	--	--	--	--	--	--	--	--	--	--	--	--	--	--	--	--	--	--	--	--	--	--	--	--	--	--	--	--	--	--	--	--	--	--	--	--	--	--	--	--	--	--	--	--	--	--	--	--	--	--	--	--	--	--	--	--	--	--	--	--	--	--	--	--	--	--	--	--	--	--	--	--	--	--	--	--	--	--	--	--	--	--	--	--	--	--	--	--	--	--	--	--	--	--	--	--	--	--	--	--	--	--	--	--	--	--	--	--	--	--	--	--	--	--	--	--	--	--	--	--	--	--	--	--	--	--	--	--	--	--	--	--	--	--	--	--	--	--	--	--	--	--	--	--	--	--	--	--	--	--	--	--	--	--	--	--	--	--	--	--	--	--	--	--	--	--	--	--	--	--	--	--	--	--	--	--	--	--	--	--	--	--	--	--	--	--	--	--	--	--	--	--	--	--	--	--	--	--	--	--	--	--	--	--	--	--	--	--	--	--	--	--	--	--	--	--	--	--	--	--	--	--	--	--	--	--	--	--	--	--	--	--	--	--	--	--	--	--	--	--	--	--	--	--	--	--	--	--	--	--	--	--	--	--	--	--	--	--	--	--	--	--	--	--	--	--	--	--	--	--	--	--	--	--	--	--	--	--	--	--	--	--	--	--	--	--	--	--	--	--	--	--	--	--	--	--	--	--	--	--	--	--	--	--	--	--	--	--	--	--	--	--	--	--	--	--	--	--	--	--	--	--	--	--	--	--	--	--	--	--	--	--	--	--	--	--	--	--	--	--	--	--	--	--	--	--	--	--	--	--	--	--	--	--	--	--	--	--	--	--	--	--	--	--	--	--	--	--	--	--	--	--	--	--	--	--	--	--	--	--	--	--	--	--	--	--	--	--	--	--	--	--	--	--	--	--	--	--	--	--	--	--	--	--	--	--	--	--	--	--	--	--	--	--	--	--	--	--	--	--	--	--	--	--	--	--	--	--	--	--	--	--	--	--	--	--	--	--	--	--	--	--	--	--	--	--	--	--	--	--	--	--	--	--	--	--	--	--	--	--	--	--	--	--	--	--	--	--	--	--	--	--	--	--	--	--	--	--	--	--	--	--	--	--	--	--	--	--	--	--	--	--	--	--	--	--	--	--	--	--	--	--	--	--	--	--	--	--	--	--	--	--	--	--	--	--	--	--	--	--	--	--	--	--	--	--	--	--	--	--	--	--	--	--	--	--	--	--	--	--	--	--	--	--	--	--	--	--	--	--	--	--	--	--	--	--	--	--	--	--	--	--	--	--	--	--	--	--	--	--	--	--	--	--	--	--	--	--	--	--	--	--	--	--	--	--	--	--	--	--	--	--	--	--	--	--	--	--	--	--	--	--	--	--	--	--	--	--	--	--	--	--	--	--	--	--	--	--	--	--	--	--	--	--	--	--	--	--	--	--	--	--	--	--	--	--	--	--	--	--	--	--	--	--	--	--	--	--	--	--	--	--	--	--	--	--	--	--	--	--	--	--	--	--	--	--	--	--	--	--	--	--	--	--	--	--	--	--	--	--	--	--	--	--	--	--	--	--	--	--	--	--	--	--	--	--	--	--	--	--	--	--	--	--	--	--	--	--	--	--	--	--	--	--	--	--	--	--	--	--	--	--	--	--	--	--	--	--	--	--	--	--	--	--	--

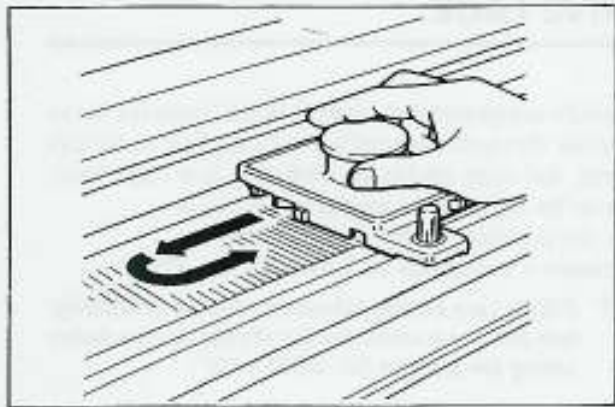

- 4 Place P Carriage (without P Presser) on the right side of Needle Bed (refer to page 60).
Move P Carriage to the left and back again so that stitches are removed and the needles align in B position again.

- 5 Set Cam Lever to "S" (SLIP) and knit 3 rows with waste yarn. (Only the ribber needles will knit.)

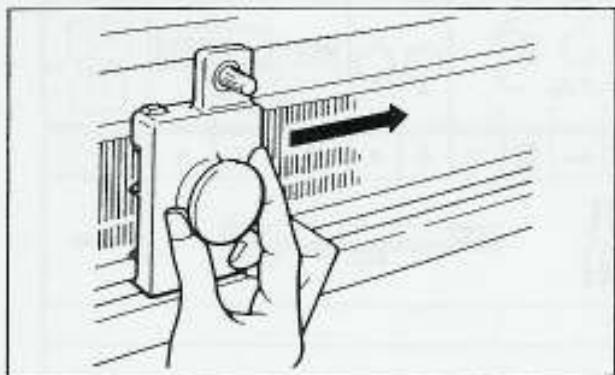

- 6 Place P Carriage on the left side of Ribber Needle Bed (refer to page 60), and slide it to the right to push up needles to C position.

- 7 Exchange waste yarn for main yarn in Yarn Feeder and knit from the left to the right.

- 8 Slide P Carriage on Ribber from the left to the right.

- 9 Knit from the right to the left.

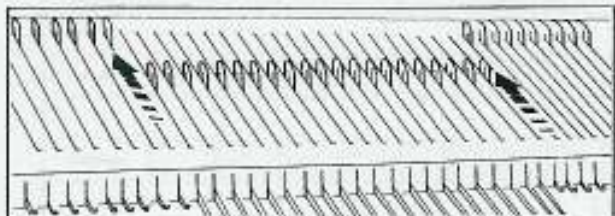

- 10 Push both end needles on Knitter to A position.

- ② — 1 Slide P Carriage on Ribber from the left to the right to push up needles to C position.

- 2 Set the Pattern Card and push OFF the Inspection Button. Knit 1 row from left to right.
(On Ribber, all the needles in C position knit, and on Knitter, only selected needles knit.)

- 3 Push up Ribber needles to C position using P Carriage.

- 4 Knit one row from the right to the left.

- 5 Remove stitches on Knitter using P Carriage.

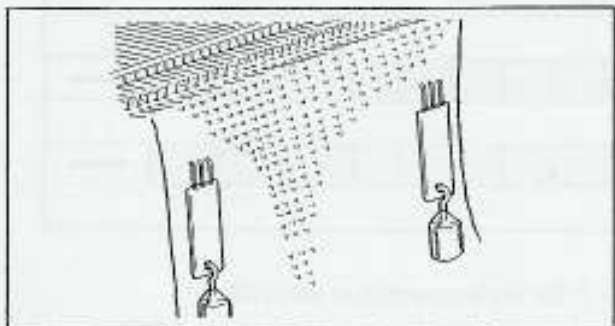

Repeat ②—1—②—5 for main knitting.

Suspend Hanger Combs with Weights after 10 rows and move them up every 10 rows.



MESH KNITTING

Mesh knitting is worked in the same manner as for drive lace knitting using thin yarn.

The sample is knitted with Pattern No. 13—(41).

When steaming, slide the iron from top to bottom of the Fabric, not from side to side.

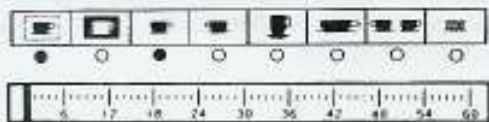

PILE KNITTING

The stitches in this fabric are formed using both ground yarn and pile yarn.

Knit using pile yarn only on Knitter and both yarns on Ribber, removing stitches.

The sample is knitted with Pattern No.13—(39) using woolly nylon yarn for ground yarn, and light yarn for pile stitch.

NOTE: If PILE KNITTING follows an other pattern, turn OFF the machine to clear the old memory before setting the machine for "PILE KNITTING".

①	1				○		●	—	=			=	6	4	↑	H	5	
2													→					
3																		
4																		
5						S												≡≡≡) 3
6																		
7						P									↓			→
8																		
9																		←
10																		
②	1																	
2																		→
3																		
4																		←
5																		

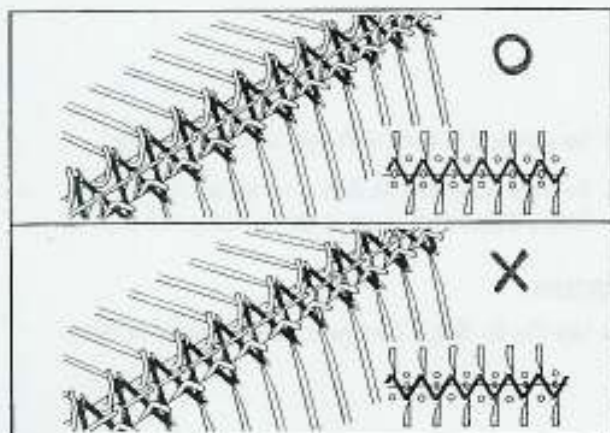

① — 1 Set machine controls as instructed.

Set *Stitch Dial* to the same number as for main knitting.

Do not use the *Button 1* with its right light on and *Button 3* and *6*.

— 2 Arrange needles as instructed and knit from the left to the right with waste yarn.

— 3 When suspending *Cast-on Comb*, insert it so that its teeth face *Ribber Sinker Posts* as illustrated.

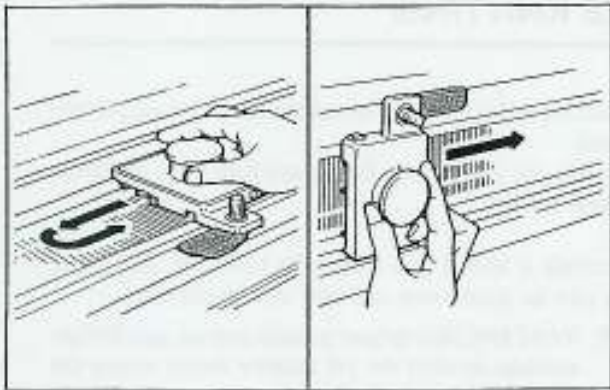

- ④ — 4 Place P Carriage with P Presser attached on the right side of Knitter Needle Bed (refer to page 60). Move P Carriage to the left and back again so that stitches on knitter are removed and the needles are aligned in B position again.

- 5 Set Cam Lever to "S" (SLIP) and knit 3 rows with waste yarn.

- 6 Place P Carriage on the left side of Ribber Needle Bed (refer to page 60), and slide it to the right to push up needles to C position.

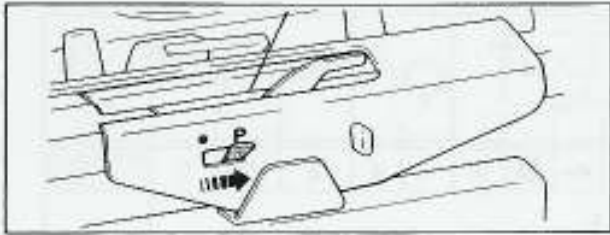

- 7 Exchange waste yarn for pile yarn in main Yarn Feeder.

Set Auxiliary Yarn Feeder Lever to P (right) position, and thread ground yarn into Auxiliary Yarn Feeder following instructions below.

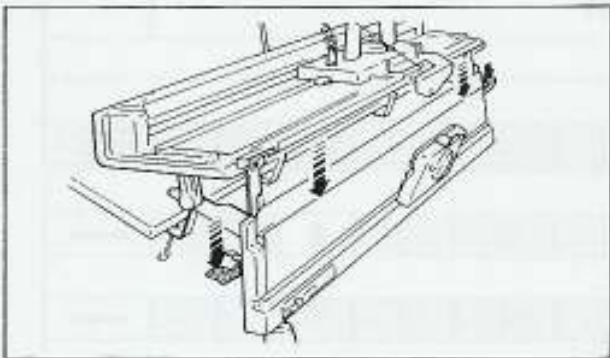

- (1) Lower Ribber Needle Bed to the middle position by depressing Drop Lever (red mark) once.

- (2) Thread ground yarn through Auto-Tension.

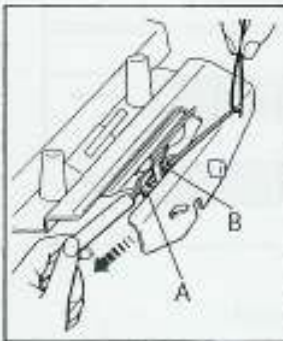

- (3) Make a loop on yarn end and hold it above Auxiliary Yarn Feeder.

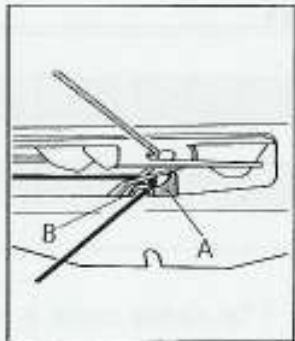

- (4) Insert Hook Tool from underneath through Auxiliary Yarn Feeder "A" and Yarn Guide "B", then catch yarn loop.

- (5) Pull Hook Tool downwards threading yarn through Yarn Guide and Auxiliary Yarn Feeder.

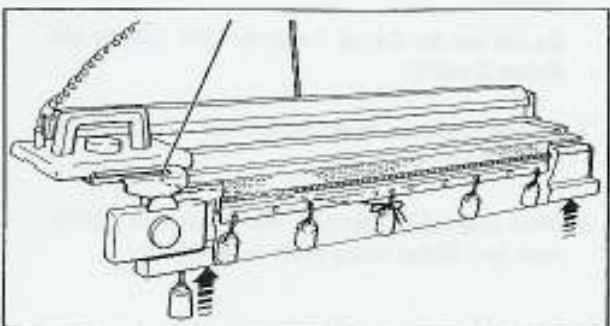

- (6) Tie yarn end to hook of Weight on Cast-on Comb.

- (7) Push up Ribber Needle Bed to its top position. Ensure Ribber needles are correctly lined up in B position.

IMPORTANT:

Ensure Link Pin on Ribber Carriage is joined properly to Ribber Arm.

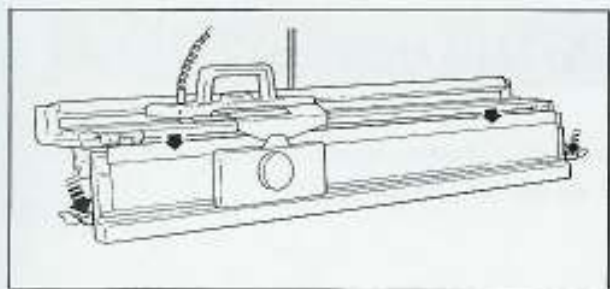

(8) Depress both Pile Levers (marked blue) to widen space between Knitter and Ribber Needle Bed.

(9) Knit from the left to the right.

If the yarns, pile yarn and ground yarn, get entangled or loosened, pull the yarns back to yarn balls at the back of Auto-Tension before moving Carriage.

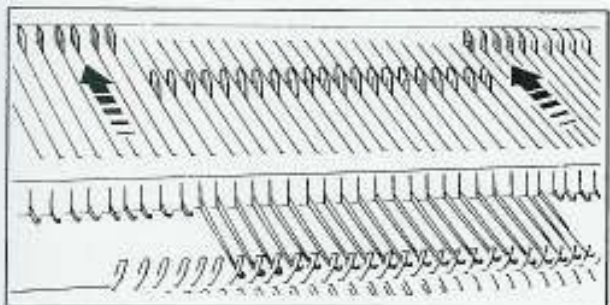

— 8 Slide P Carriage on Ribber from the left to the right.

— 9 Knit from the right to the left.

— 10 On Knitter, push 5 needles back to A position at both sides of fabric to have plain edge for seaming.

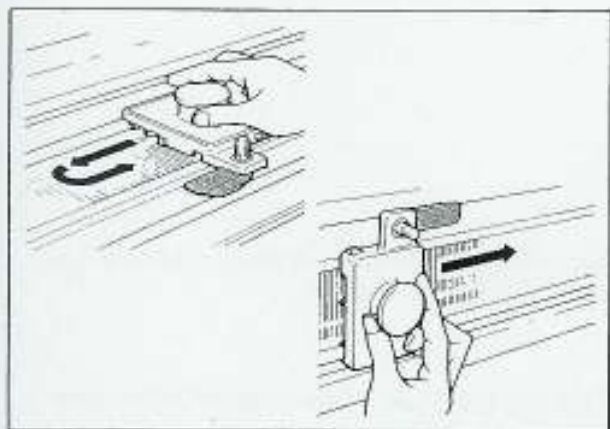

② — 1 Slide P Carriage on Ribber from the left to the right to push up needles to C position.

— 2 Set the Pattern Card and push OFF the Inspection Button.
Knit 1 row from the left to right.

— 3 Slide P Carriage on Ribber from the left to the right.

— 4 Knit 1 row from the right to the left.

— 5 Remove stitches on Knitter using P Carriage.

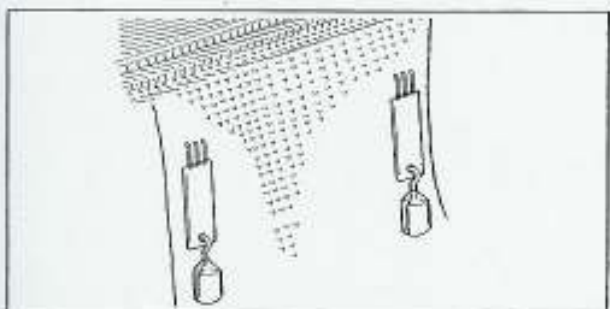

Repeat ② — 1 ~ ② — 5 for main knitting.

Suspend Hanger Combs with Weights after 10 rows and move them up every 10 rows.

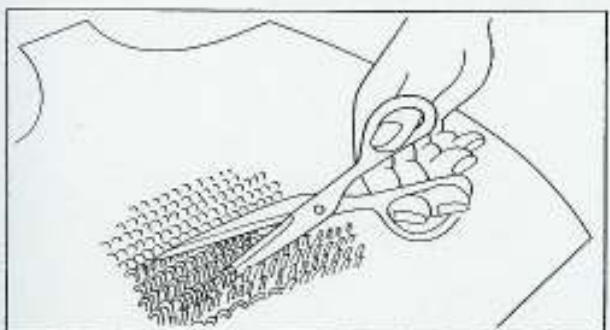

You can cut the loops of pile knitting if you wish.

To cut loops, spread fabric on a flat surface.

Insert one scissor blade into centre of loops and cut open.

Give steam to the surface of the fabric.

DO NOT PRESS.

TO USE YARN CHANGER WITH THE RIBBER

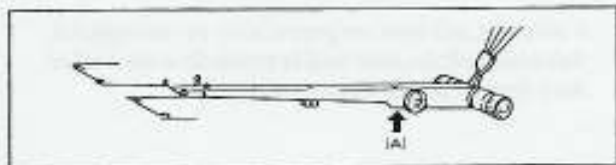

1. Fit slot of 4-colour Auto-Tension onto the top of the Yarn Rod.
(If you own YC6, use slot (B))

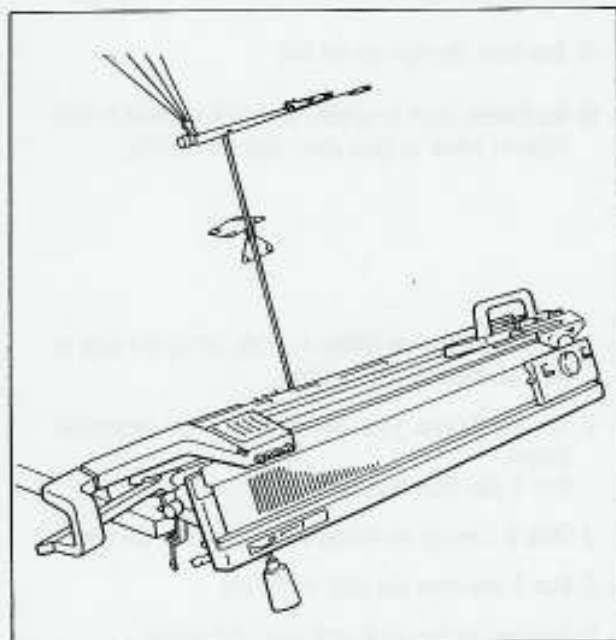

2. Set up the Ribber as usual.

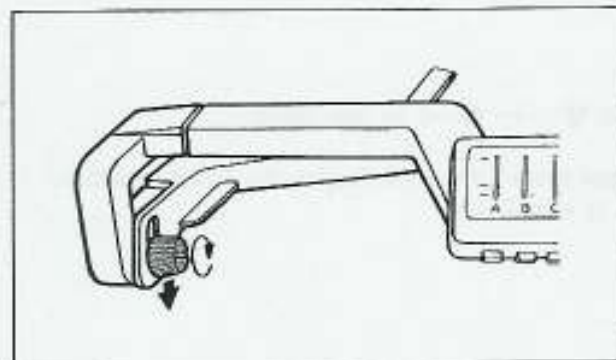

3. Fit Yarn Changer on the Knitter as shown in the Instruction Book of automatic yarn changer.

(If you own YC6, loosen Change Screw and push it down. Tighten Change Screw.)

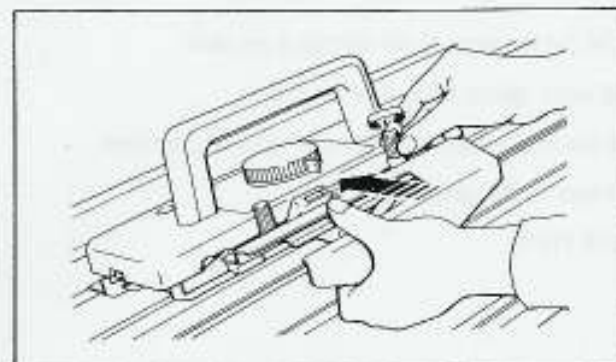

4. Attach Ribber Arm to Knitter Carriage.

● Basic knitting



Using the Yarn Changer, but without using the Pattern Card, you can knit striped pattern on the fabric easily.

The sample opposite is knitted using four colours in Double Rib stitch.

Holder A = Purple
Holder B = Black
Holder C = Red
Holder D = Yellow

Knit the striped pattern following the instructions below.

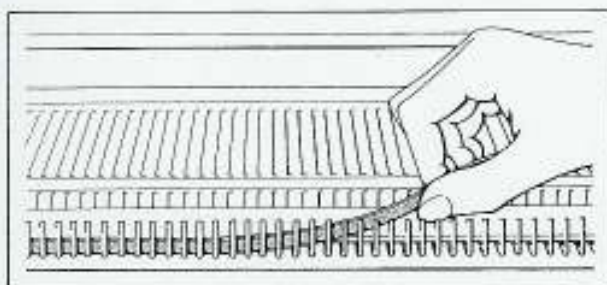

1. Insert Close Knit Bar between Knitter sinker posts and front edge of needle bed.

2. Set machine controls as instructed below and referring to the diagram.

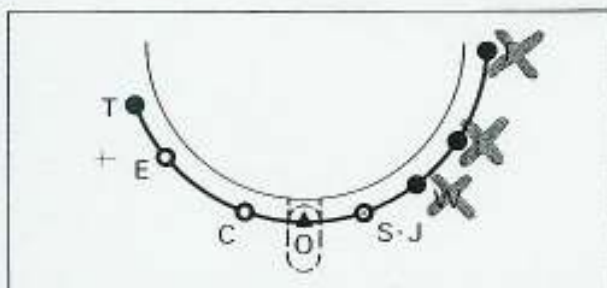

- | | |
|---|---------------|
| ① Russell Levers (Knitter)..... | |
| ② Cam Lever*..... | 0 (STOCKINET) |
| *Never set Cam Lever to "F" (KNIT-IN), "L" (PUNCH LACE) and "W" (WEAVING) while using Yarn Changer. | |
| ③ Russell Levers (Ribber)..... | = |
| ④ Set Levers..... | □ |
| ⑤ Pick Knob..... | ▲ |
| ⑥ Stitch Dials (Knitter & Ribber)..... | 0 |

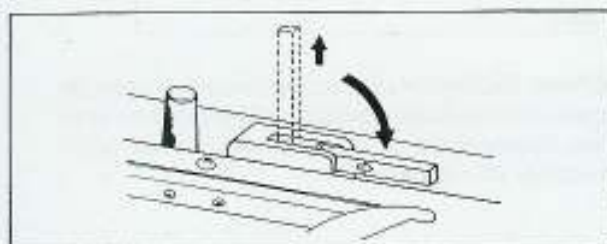
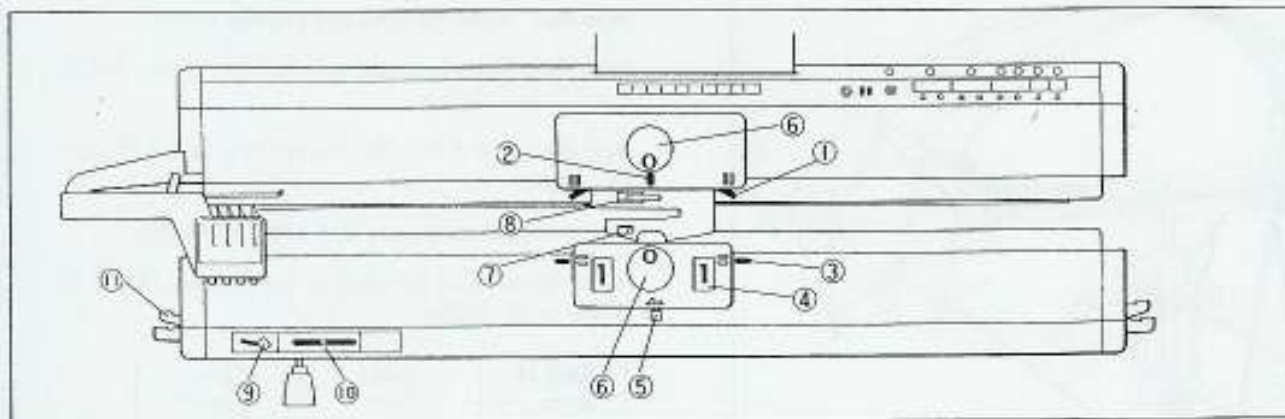

- | | |
|--|-------------------|
| ⑦ Auxiliary Yarn Feeder Lever..... | ● |
| ⑧ Driving Lever..... | resting position* |
| *If Driving Lever is in upright position, lay the lever down after pulling it up slightly. | |

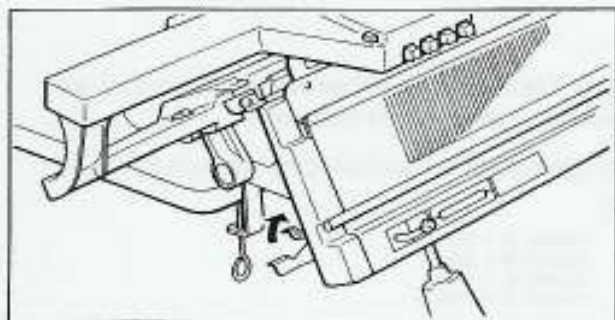

- ⑨ Half-Pitch Lever..... H
- ⑩ Swing Indicator..... 5
- ⑪ Pile Levers (left & right)..... upper position*

*If Pile Levers are at lower position push them up so the distance between Knitter and Ribber is narrowed.

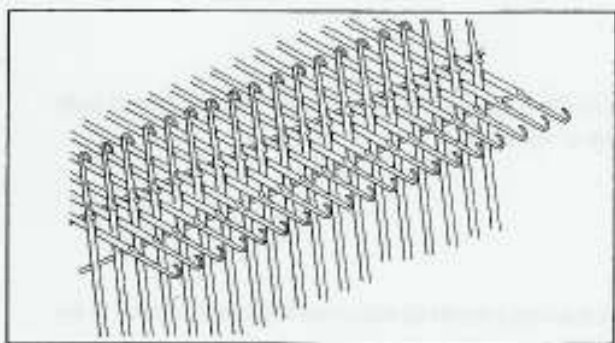

- Using the straight edge of Needle Pusher push the same number of needles on Knitter and Ribber to D position.

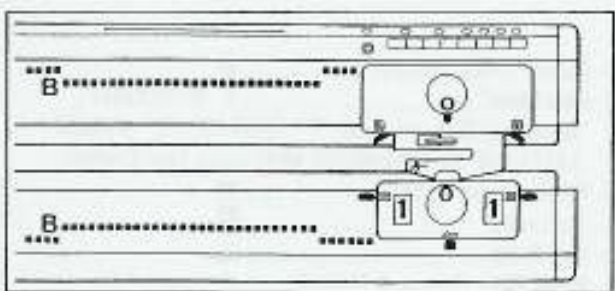

- Move Carriage 2—3 times to align needles in B position finishing with Carriage at the right.

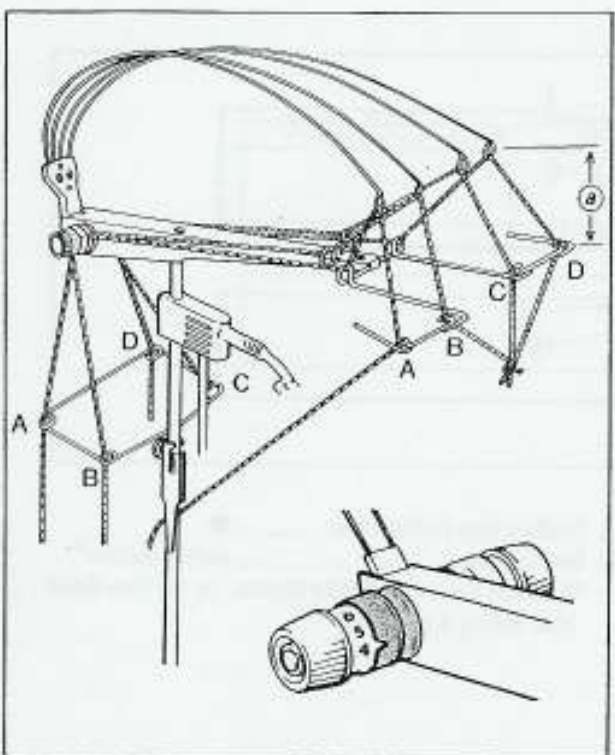

- Thread four yarns of different colours into Auto-Tension.

Important: follow the threading diagram exactly.

Guide the yarns as illustrated and designate the yarns as A, B, C and D from the left.

Hook the yarn A in Yarn Clip, this yarn is to be threaded into Yarn Feeder.

Tie the ends of other yarns, B, C and D as illustrated.

Adjust Tension Dial according to the thickness of yarn as shown in the diagram.

Kind of yarns	Light yarn	Thin yarn
Tension Dial	4 - 5	5 - 6

If different thickness of yarns are used together, adjust the Tension Dial to maintain the distance (ⓐ) between the tip of the Tension Spring to the top of Auto-Tension at approximately 10—30cm.

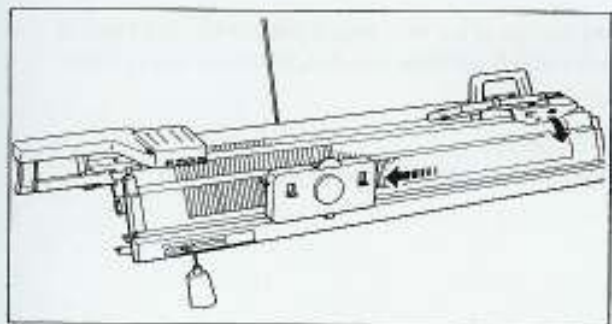

6. Disconnect Ribber Carriage from Arm and move it to the side of Yarn Changer, tilting it towards you.

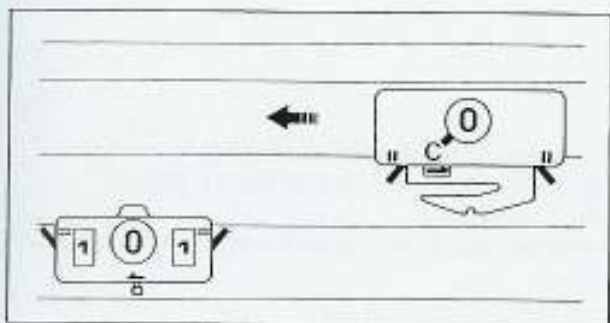

7. On Knitter Carriage, set Cam Lever to "C" (CIRCULAR).
Remove yarn A from Yarn Clip and thread it into Yarn Feeder. Holding the yarn underneath the machine, move Knitter Carriage from the right to the left without knitting and connect it to the Ribber Carriage.

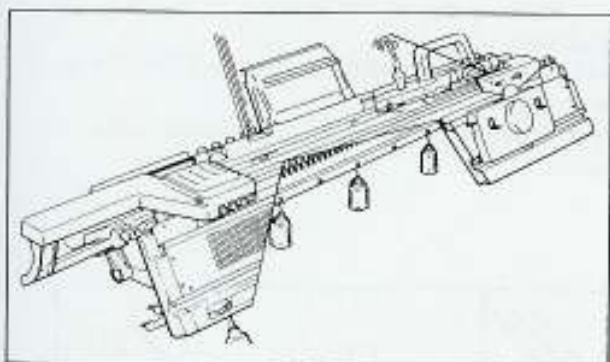

8. Re-set Cam Lever to "D" (STOCKINET) and knit the initial row from the left to the right.

9. Suspend Cast-on Comb with Weights.

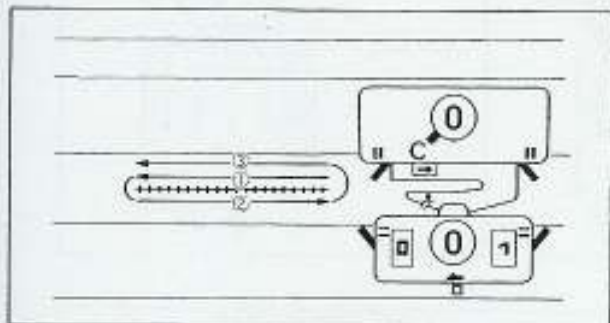

10. Knit subsequent 3 rows for cast-on changing the carriage settings as follows:

Cam Lever.....C (CIRCULAR)
Set Lever (left).....**0**

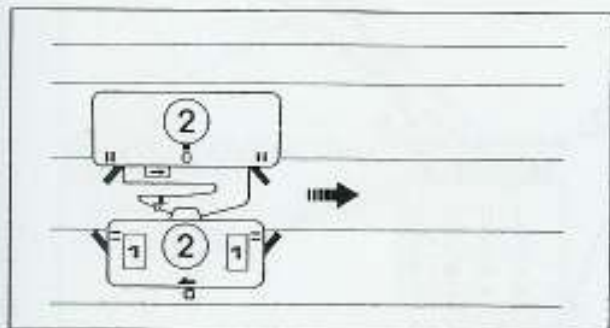

11. Re-set left Set Lever to **1** and set Stitch Dials to 2, then knit one row from the left to the right.
Set the Driving Lever to the upright position.

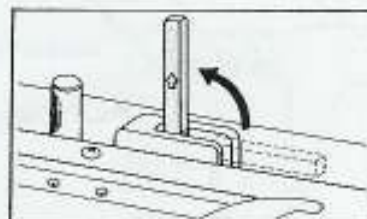

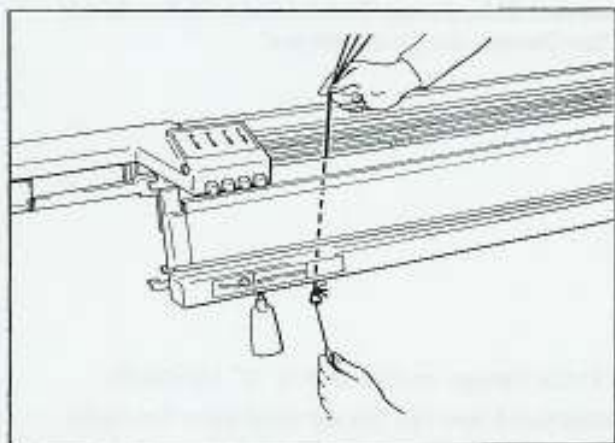

12. Hang the knot of the three yarns between both needle beds at the left side. Insert Hook Tool from underneath and catch the knot.

IMPORTANT:

Bring the three knotted yarns in front of Yarn A.

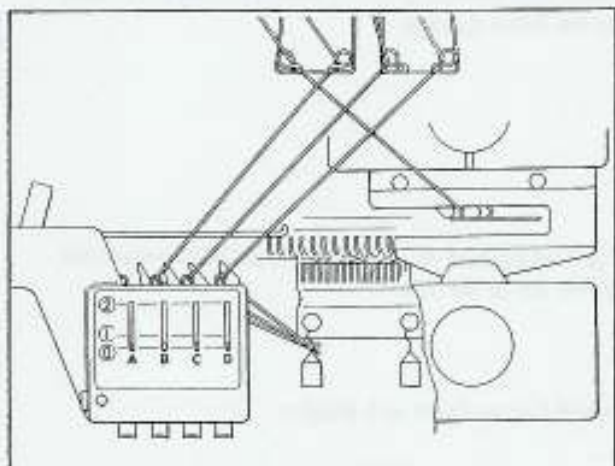

13. Hook the knot on Weight Hook suspended on Cast-on Comb. Hook yarn B on Holder B, yarn C on Holder C and yarn D on Holder D respectively.
(Arrange the yarns so that they are not entangled with Sinker Posts.)

14. Arrange Holders as follows.

- (1) Push Holder Button A. The Holder is positioned in the ① position.
- (2) Push Feeding Lever to the left to bring out Holder A to the ② position.
- (3) Push Holder Button B. Holder is positioned in the ① position.

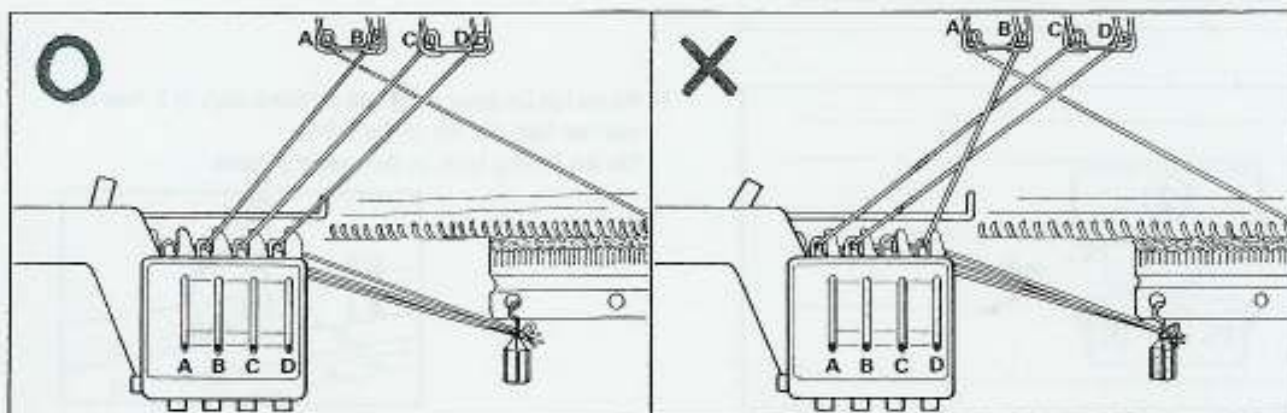
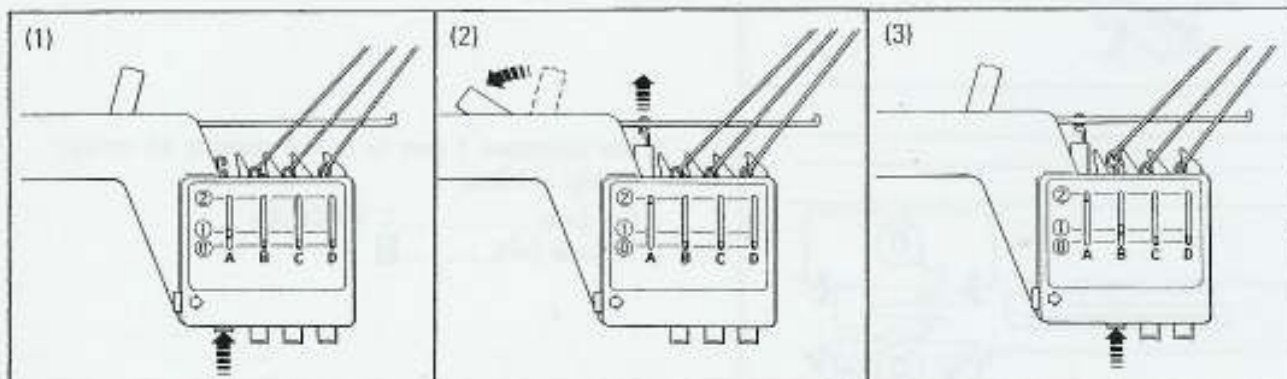

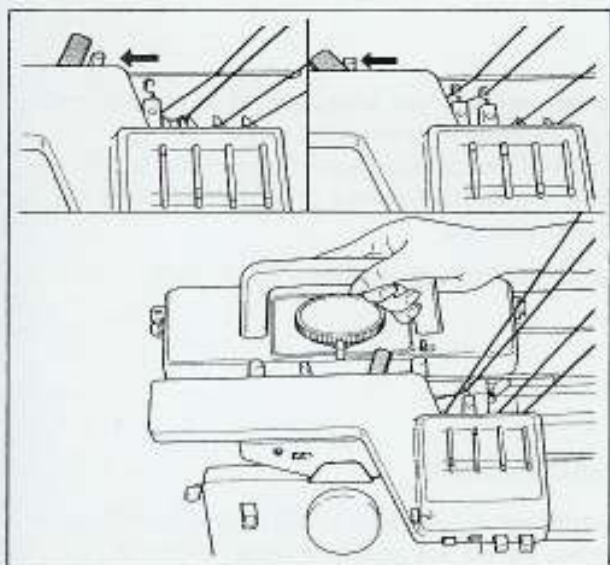

15. For main knitting set both Stitch Dials to 4 and move Carriage from the right to the left till Driving Lever hits Feeding Lever and yarn changing is completed. When yarn changing is accomplished, a click is heard.

Repeat this procedure until you knit desired number of rows changing yarns automatically. (Yarn A and yarn B are knitted alternately every two rows.)

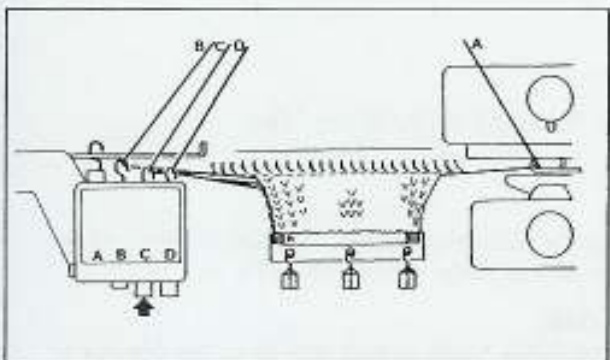

16. To exchange yarn B for C, leave Carriage at right side with yarn A in Yarn Feeder and push Holder Button C. (Holder B will be back to ① position.)

17. Knit desired number of rows changing two yarns A and C.

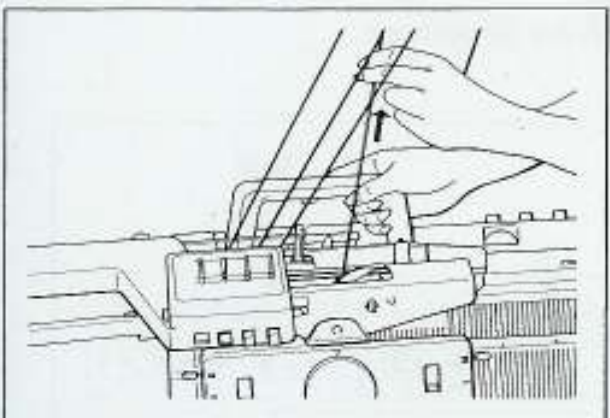

If more than three yarns are used, the Auto-Tension may not be able to take up slack on the yarn properly. In this case, slightly pull up the yarn above the Yarn Feeder, and also to correct possible entanglement of the yarns.

When the Automatic Yarn Changer is used, the 4-Colour Auto-Tension must be used.

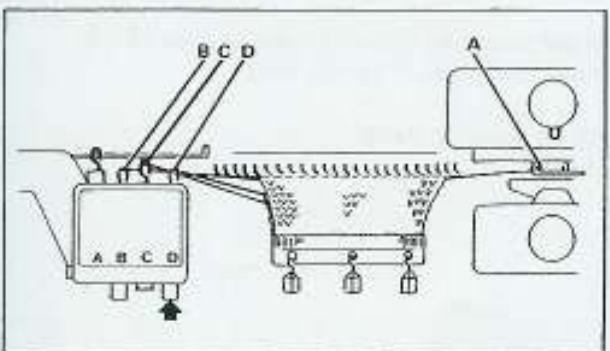

18. In the same manner as done in step 16, change yarn C to D.

Repeat steps 15—18 to knit striped pattern in double rib.

● Double Jacquard

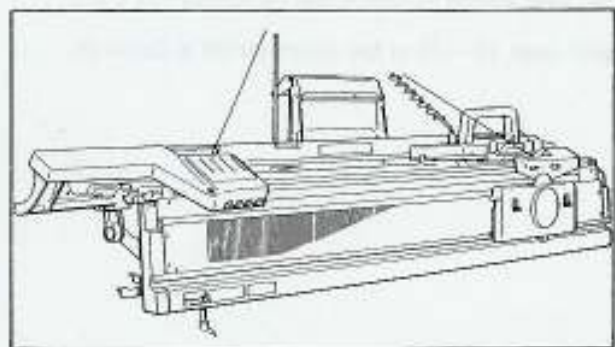
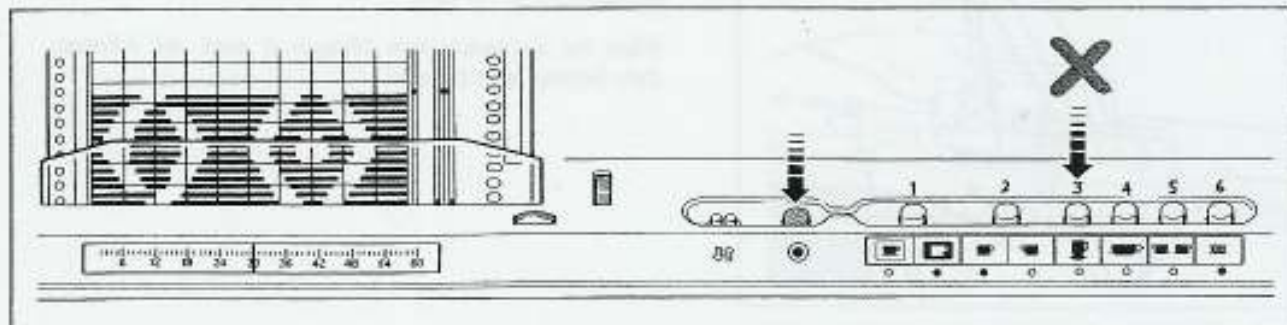
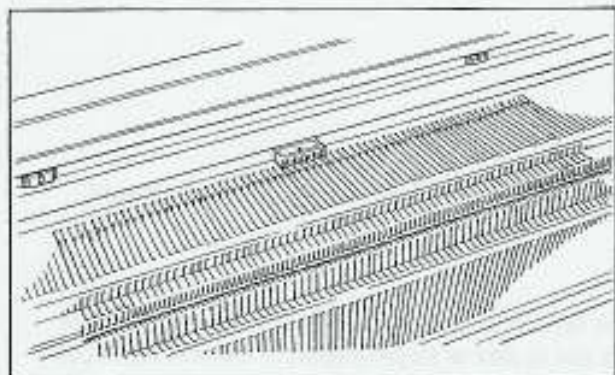
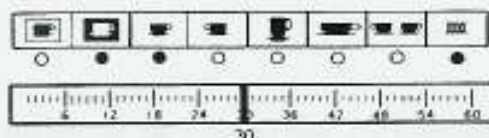

Double Jacquard — a fabric knitted with the use of the Pattern Card, and having no floats of yarn on its back.

Using the Yarn Changer and a Pattern Card, pattern is formed on the knitter side, with the Cam Lever set at "J" (JACQUARD), and Ribber knits every row.

The sample is knitted with the Pattern No.13—(39).

PREPARATORY STEPS

Referring to steps 1—7 for basic knitting on pages 87—89, set the machine controls and arrange the needles for cast-on.

Set the Point Cams and the Needle-1 Cam.

Turn on the machine and push on the Inspection Button to set pattern controls. (Refer to pages 19—21.)

IMPORTANT:

Use the Button 1 with its right light on for the first row of pattern. (This setting will change automatically during knitting.)

DO NOT USE THE BUTTON 3.

Cast on and arrange the Holders, referring to pages 89—90. (Finish with the Carriage at the right side.)

Push off the Inspection Button. (Light is off.)

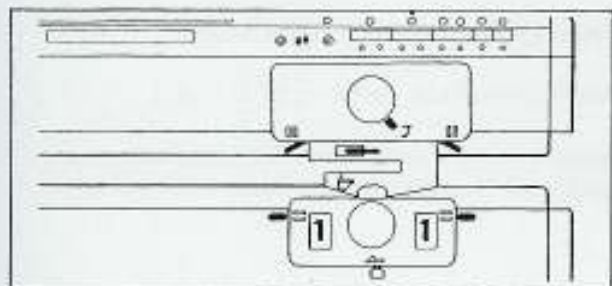

TO KNIT IN DOUBLE JACQUARD

Set the Cam Lever to "J" mark.
(Other settings must remain unchanged.)

Select the Stitch Dial numbers of Knitter and Ribber referring to the instruction below.

thickness of yarn	thin	light	medium*
stitch dials (Knitter & Ribber)	2 - 3	3 - 5	5 - 7

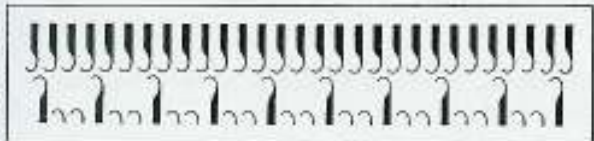

Thickness of yarns suitable for DOUBLE JACQUARD are thin and light yarns. Select Stitch Dial settings as listed opposite.
*To knit double jacquard using medium yarn, arrange needles as illustrated opposite with the Half-Pitch Lever at "H" and Swing Indicator at "5".

Note: Cast-on rows must be knitted on the needle arrangement for double rib. (all needles on both beds.)

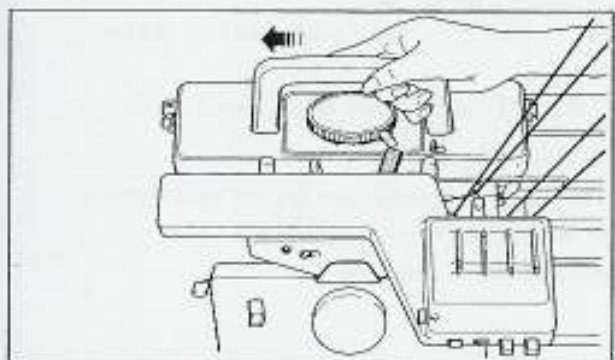

Start knitting from the right to the left till Driving Lever hits Feeding Lever to change the yarn every two rows.
(Two lights of the Button 1 change automatically every two rows.)

While knitting, change the yarns following the mark on the yarn change column by pushing the respective Holder Button when a buzzer sounds.

The Holder Button holding the yarn to be selected next must be pushed when the Carriage is at the right side.

IMPORTANT: In Double Jacquard, one pattern row is formed with two rows of knitting, first row with the ground yarn, and the second with the contrast yarn.

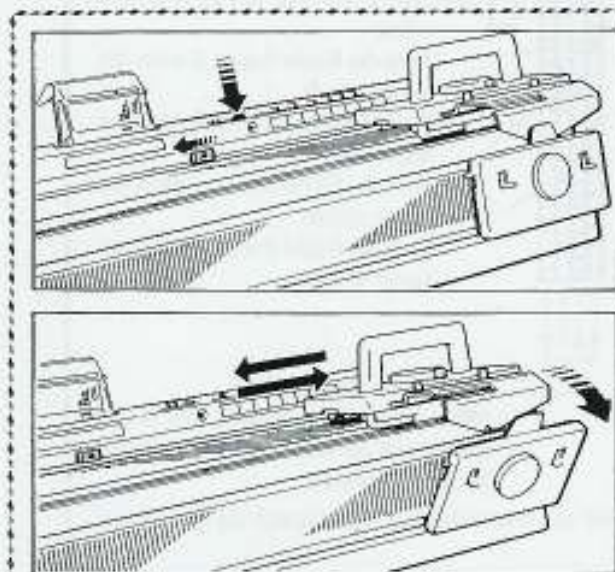
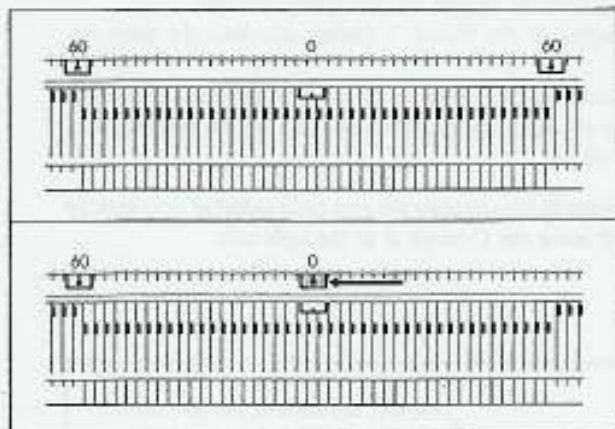
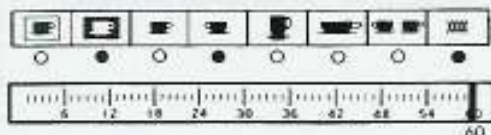
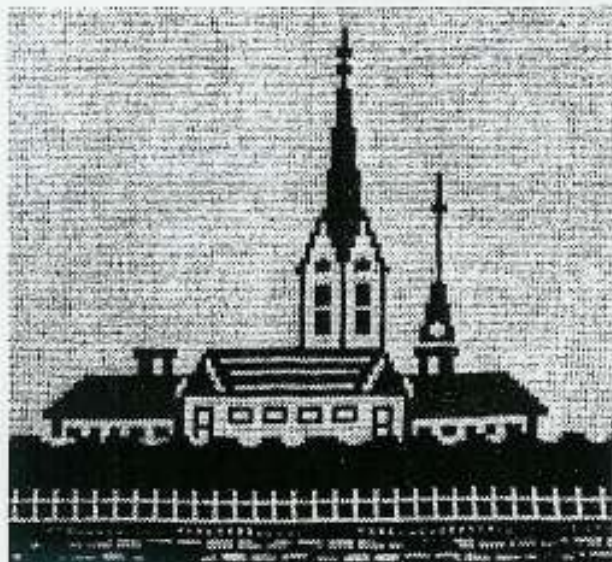

Single motif knitting is possible in Double Jacquard.

The sample is knitted with the Pattern No.15—(45).

The sample is knitted using four yarns of different colours over 120 needles with the partial use of the Button 5 (Mirror Image).

On the Notation Column, mark 41st and 61st rows before setting the Pattern Card into the machine.

Set the Point Cams and Needle-1 Cam as illustrated in diagram 1 and work ordinary Double Jacquard. (1st row to 40th row of the Pattern Card.) — 80 rows of knitting.

Push "ON" the Pattern Button 5 (Mirror Image)

Knit from 41st row to 60th row.

Move right Point Cam as illustrated in diagram 2 and memorize its position, referring to the instruction below.

Knit from 61st row to 150th row.

When the Card has returned to the first row, lay down the Driving Lever and continue to knit with the yarn A.

To move the RIGHT Point Cam,

- (1) Leave the Carriage at the right side.
- (2) Push on the Inspection Button.
- (3) Move the RIGHT Point Cam to specified position.
- (4) Disconnect the Ribber Carriage.
- (5) Move the Knitter Carriage twice without knitting by using Release Lever.
- (6) Push off the Inspection Button.
- (7) Connect the Ribber Arm and the Ribber Carriage.

● Knitting on the knitter using YC5.

With the use of the Yam Changer, and supported by the Ribber, stripe pattern in stockinet, tuck and slip stitches in colours, using the Pattern Card for the knitter can be knitted easily.

(If you own YC6, you can knit changing yarns automatically without Ribber. Refer to the Instruction Book of YC6.)

Cast on using the Knitter and the Ribber and then follow the procedure set forth below.

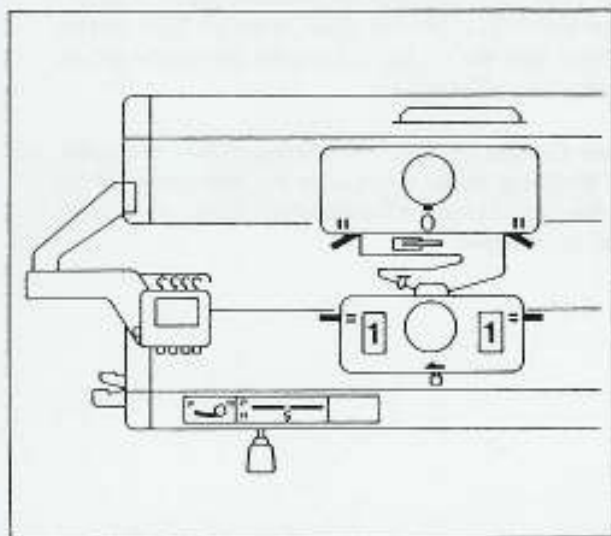



1. Set the machine controls as follows:

KNITTER

Cam Lever..... "0" (STOCKINET)
 Russel Lever..... II (both)
 Auto-Tension Dial..... To be adjusted.

RIBBER

Set Lever..... I (both)
 Pick Knob..... 
 Russel Lever..... = (both)
 Driving Lever..... resting position
 Auxiliary Yam Feeder Lever..... 
 Pile Lever..... 
 Swing Indicator..... H-5
 Stitch Dials (Knitter & Ribber).....
 Select the number according to thickness of yarn.
 (Refer to page 93.)

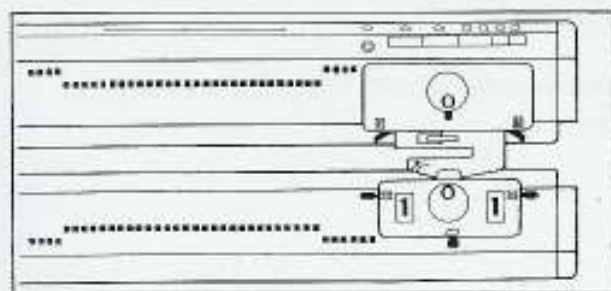

2. Arrange the needles for Double Rib and move the Carriage 2—3 times and leave it at the right side.

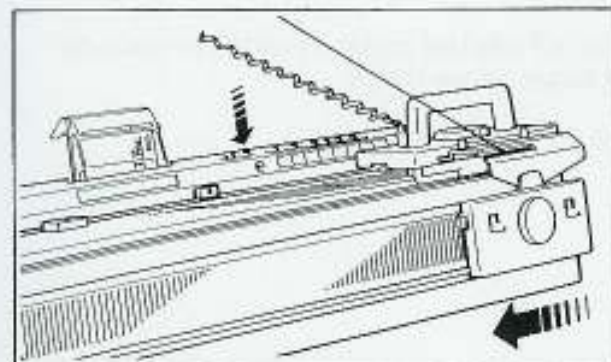

3. Turn ON the machine and push "ON" the Inspection Button.
4. Set the pattern controls, Point Cams, and the Needle-1 Cam at either of the Point Cams.
5. Thread waste yarn through Yam Feeder and knit one row from right to left. (The yarn will be hooked alternately on the two rows of needles in service in a zigzag pattern.)

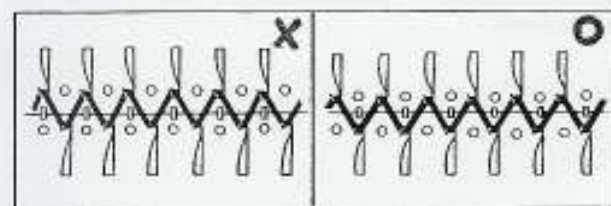

6. Insert Cast-on Comb between Knitter and Ribber so that its teeth face to Knitter Sinker Posts, and then suspend Weights on the Comb as shown opposite.

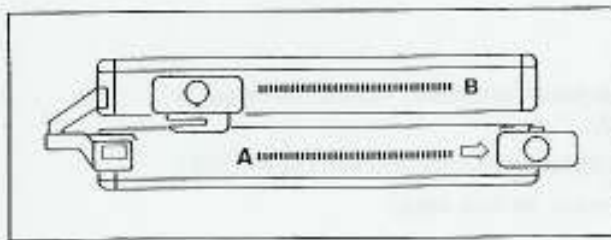

7. Disconnect Ribber Carriage from Arm, Move Ribber Carriage from the left to the right removing stitches on Ribber, then remove the Carriage from Needle Bed.

8. Push Ribber needles to A position using Needle Pusher.

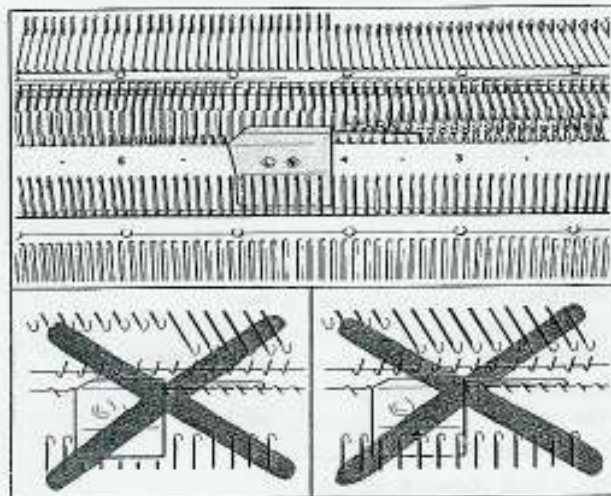

9. Insert End Stitch Holders under Ribber needles as far as they go at both ends of fabric as shown on the left. By setting the Holders, both end stitches of fabric and the yarn are pressed against Knitter Sinker Posts.

Place End Stitch Holder 1—2 needles off the end of fabric as illustrated below. If you place the bent portion of the Holder under needles in B position, Yarn Feeder and needles may be damaged.

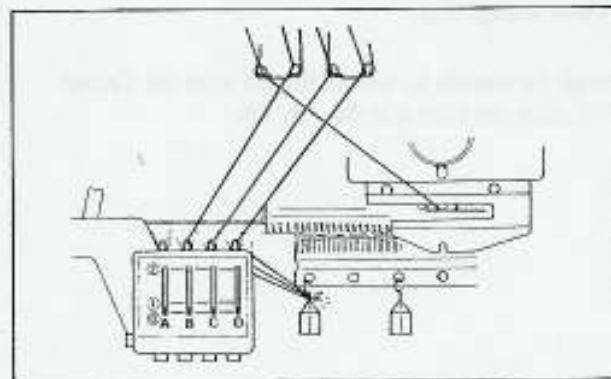

10. Knit three rows in waste yarn using Knitter Carriage. Exchange waste yarn for main yarn and knit two rows leaving Carriage at the right side.

11. Place the contrast yarns into Holders of YC and arrange their positions.

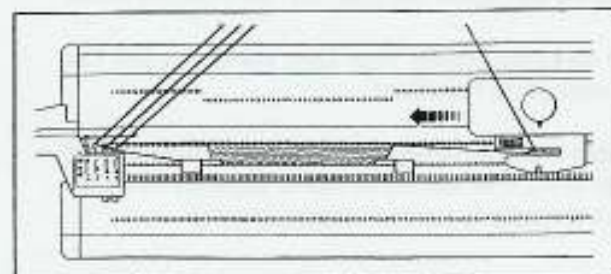

12. Raise the Driving Lever and knit one row from the right to the left reaching the yarn changer.

13. Push OFF the Inspection Button.

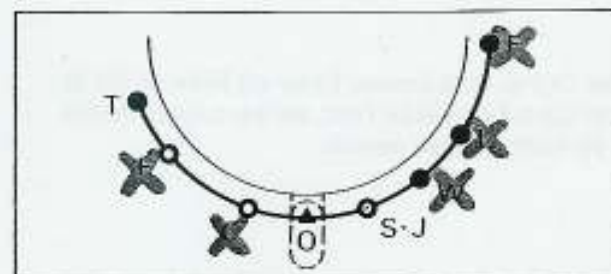

14. With the Cam Lever at the position you desire (O, T or S), start to knit changing yarns by pushing the Holder Buttons at the row you desire.

REPACKING THE RIBBER

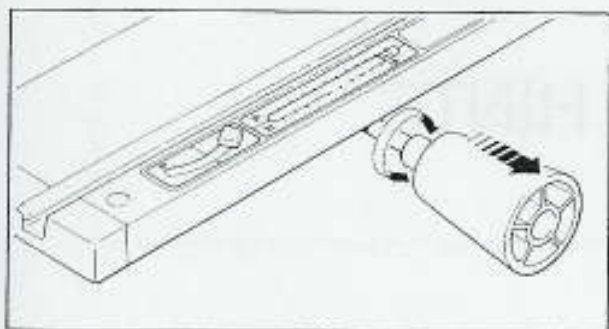

1. Disassemble Ribber by reversing the procedure for assembling. Set Swing Handle at H—10 and pull it out by twisting and pulling it.

2. Before putting back Needle Bed into the box, fit polystyrene packings to both ends of Needle Bed in the following manner.—

With the back of the Needle Bed facing you, and with the sinker posts at the top, fit the polystyrene marked "R" to the right end, and "L" to the left end.

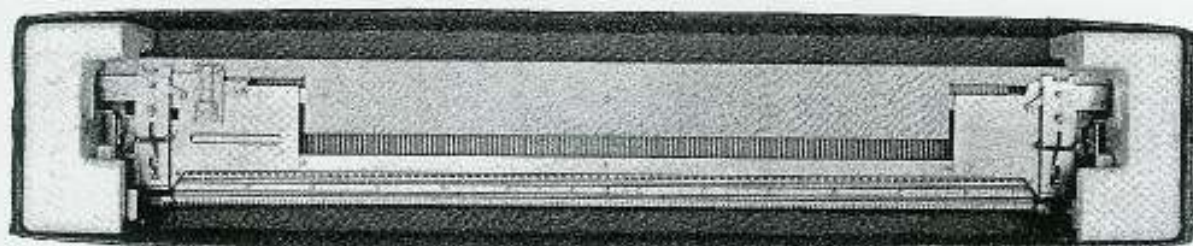

3. Replace Accessories as shown below, then place polystyrene on top of Needle Bed in box.

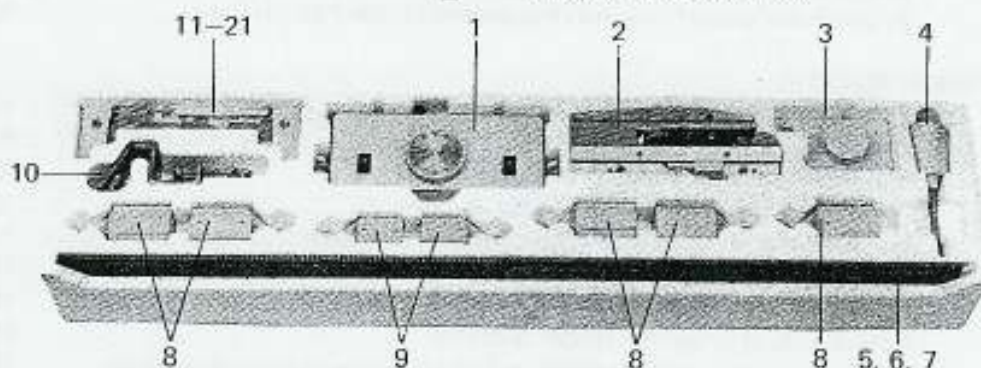

- | | |
|--|--|
| 1 Ribber Carriage | 11 P Presser |
| 2 Ribber Arm | 12 Needle Pusher (2/1, 2/2) |
| 3 P Carriage | 13 Screw Driver |
| 4 Swing Handle | 14 Auxiliary Piece (L) |
| 5 Close Knit Bar | 15 Auxiliary Piece (R) |
| 6 Cast-on Comb (long)
Cast-on Wire (long) | 16 Side Hanger |
| 7 Cast-on Comb (short)
Cast-on Wire (short) | 17 Hanger Comb |
| 8 Ribber Weight (large) | 18 Hook Tool |
| 9 Edge Weight | 19 Double-eye Transfer Tool |
| 10 Ribber Clamp | 20 Spare Needle Envelope (incl. 3 needles) |

TECHNICAL HINTS

CONTENTS

IF YOU WANT TO...	page
To unravel the knitting	99
To change the pattern controls or the other settings of the machine during pattern knitting	100
To turn off the machine during knitting	101
To knit stockinet during pattern knitting	101
To knit a selected pattern row repeatedly	101
To check the knitted row with the pattern on the Pattern Card	101
WHAT TO DO IF...	
If the Standard Carriage has jammed	102
If the Lace Carriage has jammed	103
If the Carriage has jammed in rib knitting	104
If P Carriage has jammed	104
If a stitch has dropped during knitting on the Knitter	105
If incorrectly knitted	106
If a stitch has dropped when the Ribber is in use	108
If stitches float when the Ribber is in use	108
If the end stitches are not stable or if the Carriage is heavy to operate	109
If the Ribber Arm does not fit on the Standard Carriage properly	109
If you knit with the Knitter only with the Ribber is connected	109
If you use 4-Colour Auto-Tension for knitting other than double jacquard ...	109
If the Holder Buttons of the Yarn Changer were erroneously operated	110
If the Yarn Changer is stuck on the Needle Bed	110
If a needle has been damaged	111
MAINTAINING THE MACHINE	112
DRAWING A PATTERN ON THE DESIGN CARD	113
PATTERN AND STITCH TYPE POSSIBILITIES	114

IF YOU WANT TO.....

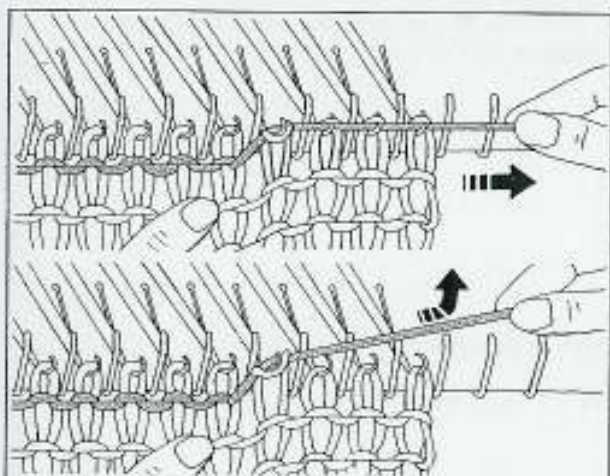

To unravel the knitting

IN CASE OF UNRAVELLING THE FABRIC ONLY ON THE KNITTER.

- (1) Hang the Claw Weights on both edges of the fabric.
- (2) Holding the fabric downwards with your left hand, pull yarn sideways.
- (3) Lift the yarn upwards and very slightly backwards. The stitches of previous row slide back into needle hooks.

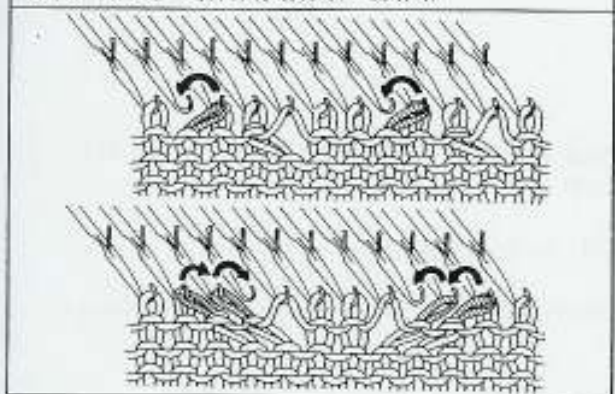

IN CASE OF UNRAVELLING THE LACE STITCH FABRIC, place the transferred stitches back on their original needles before unravelling.

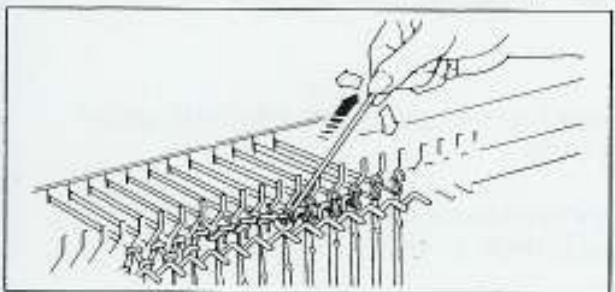

IN CASE OF UNRAVELLING RIB STITCHES.

Hold yarn and unhook it from Knitter and Ribber needle hooks by pulling it in the arrowed directions in a zigzagging manner until yarn comes to Carriage side.

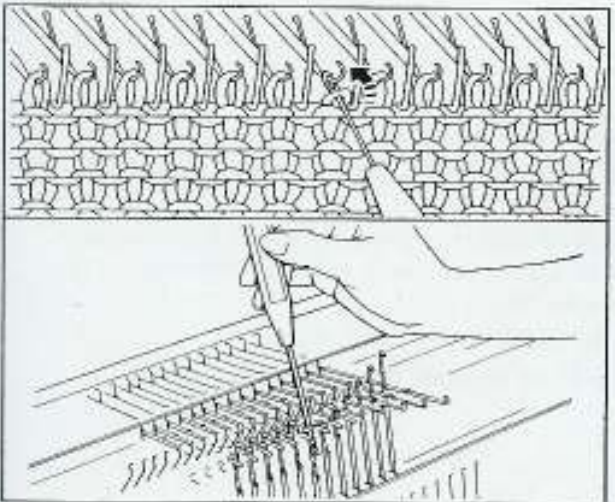

Ensure all stitches are in the needle hooks and the needles are in B position.

If some of stitches are not in needle hooks, place them into the hooks using the Transfer Tool.

Repeat the above procedure until the required number of rows have been unravelled.

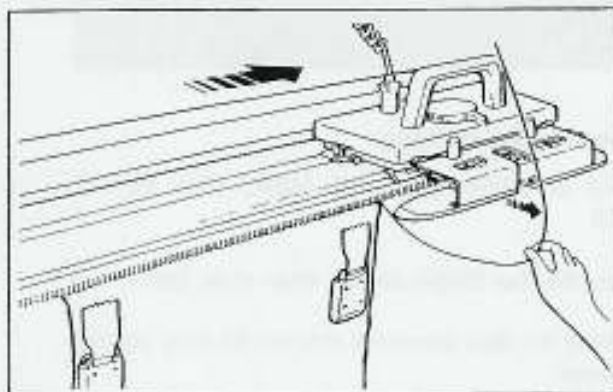

To change the pattern controls or the other settings of the machine during pattern knitting

Before changing the Pattern Controls or the other settings of the machine, make sure the Carriage is clear of the working position needles. Remove the yarn from the Yarn Feeder.

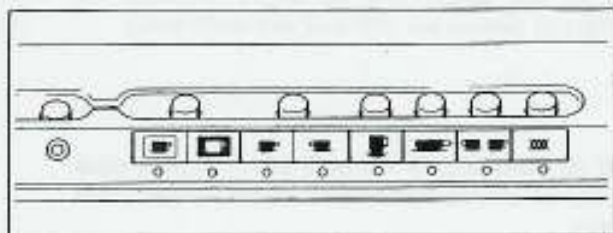

TO RE-SET THE PATTERN BUTTONS

Push "ON" or "OFF" the selected Pattern Button, and continue knitting.

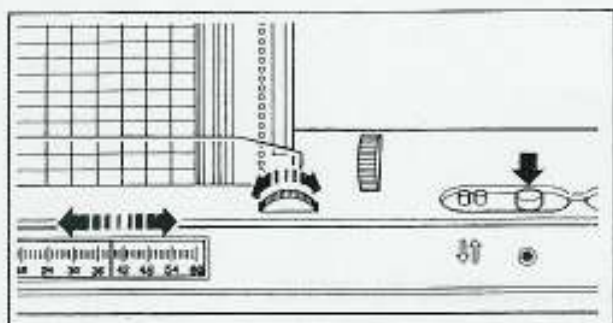

TO CHANGE THE PATTERN WIDTH INDICATOR OR THE PATTERN CARD

Push "ON" the Inspection Button. (Light is on.)

Re-set the Pattern Width Indicator, or exchange the Pattern Cards.

Push "OFF" the Inspection Button and start knitting.

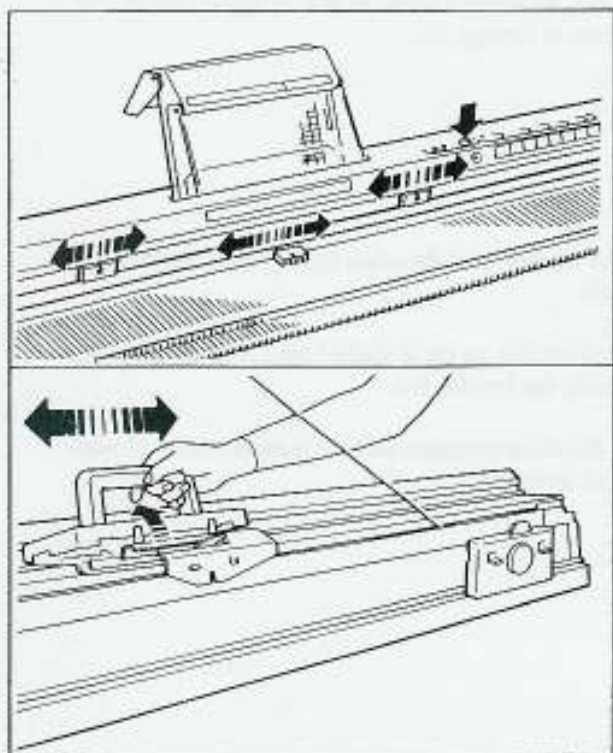

TO CHANGE THE POSITIONS OF BOTH POINT CAMS AND/OR NEEDLE-1 CAM.

Push "ON" the Inspection Button (light is on.) move the Point Cams and/or Needle-1 Cam to the new position.

To memorize the new positions of the Point Cams and/or the Needle-1 Cam, move the Carriage twice without knitting (by pushing the Release Lever.)

(If the SRP-50 Ribber is in use, disconnect the Ribber Arm from the Knitter Carriage and pass it twice without knitting — by operating the Release Lever.)

Re-set the Carriage to the original setting.

Push "OFF" the Inspection Button and continue knitting.

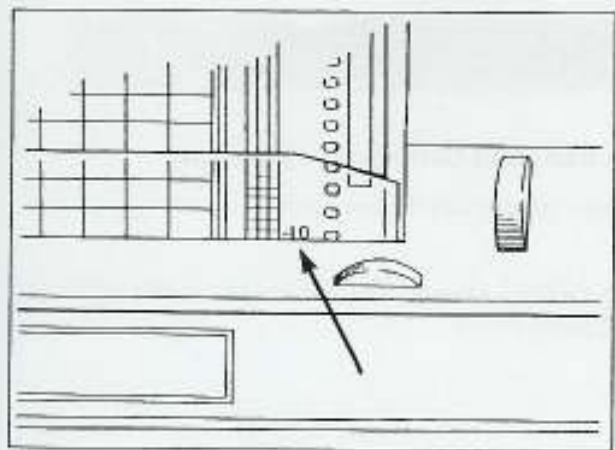

To turn off the machine during knitting

With the Inspection Button on, note the row number showing at the Card Slot before turning off the machine.

To start knitting again,

1. Turn on the machine, and move the Carriage twice to memorize the positions of the Point Cam and Needle-1 Cam.
2. Set the Pattern Card so that the noted row number is above the Card Slot. (Inspection Button light is on.)
3. Push "OFF" the Inspection Button to memorize the row to be knitted next. (light is off.)

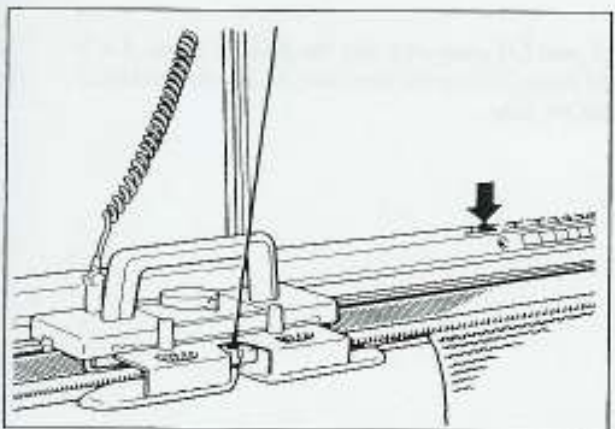

To knit stockinet during pattern knitting

Push "ON" the Inspection Button and knit with the Cam Lever at "0" (STOCKINET).

If you fail to push "ON" the Inspection Button, the Pattern Card continues to advance.

To knit in pattern knitting again, re-set the Cam Lever to the original position and push the Inspection Button "OFF".

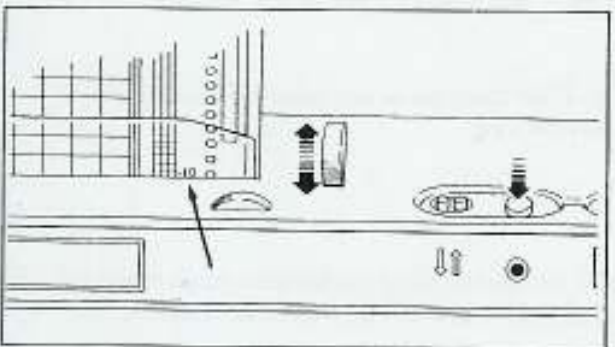

To knit a selected pattern row repeatedly

1. Push "ON" the Inspection Button.
2. Set the selected pattern row of the Pattern Card at the Card Slot.
3. Push "OFF" the Inspection Button, the Card goes in and the selected pattern row is memorized.
4. Push "ON" the Inspection Button, the Card comes out and stops.
5. Start knitting, the same row is repeated.

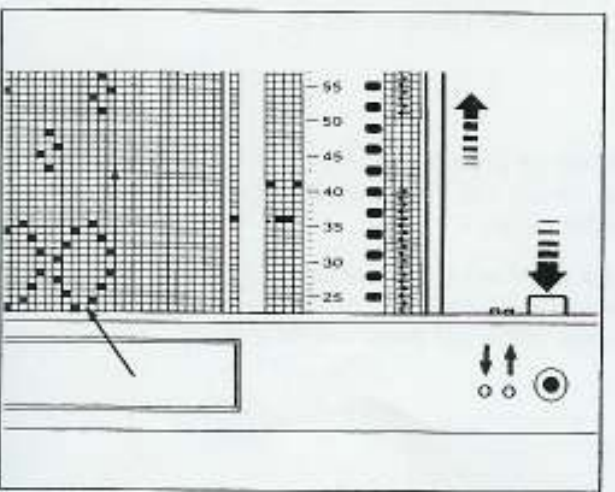

To check the knitted row with the pattern on the Pattern Card

1. Push "ON" the Inspection Button, and the Card comes by 10 rows to show the row to be knitted up next, at the Card Slot.
2. Feed the Card an additional row to the direction opposite the Feeding Direction Pointer. This row of pattern corresponds to the last row knitted.

To start knitting again, return the Card by one row to its original position. Push "OFF" the Inspection Button.

IN CASE OF LACE STITCH, check the arrow mark on the Pattern Card with the position of the Carriage before starting to knit again.

WHAT TO DO IF.....

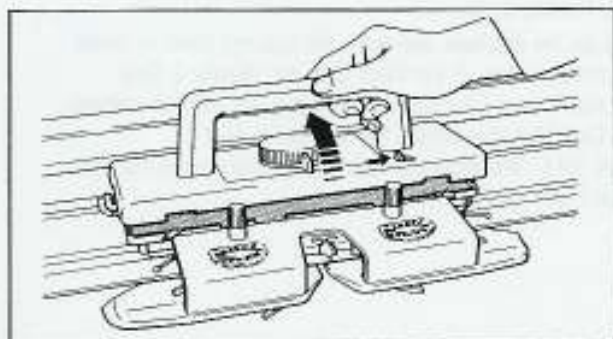

If the Standard Carriage has jammed...

1. Remove the yarn from the Yarn Feeder.
2. Push the Release Lever in the arrow direction, and the top of the Carriage lifts up.

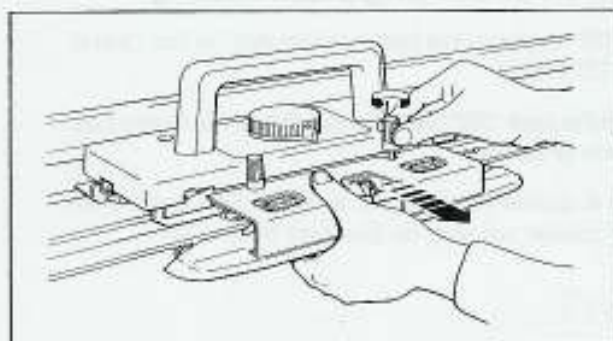

If the yarn has entangled with the Brushes on the Arm or Yarn Feeder, remove the Arm from the Carriage and disentangle the yarn.

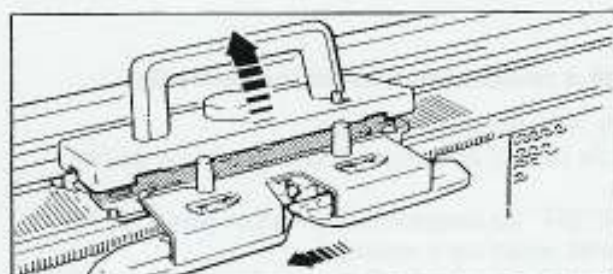

3. With the top of the Carriage up, move the Carriage in the direction it was going till it gets clear of the fabric.

If the Point Cams are in use, move the Carriage until it passes the Cam.

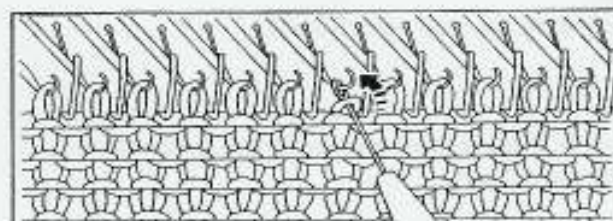

4. Check the stitches, and if stitches have moved behind the latches, replace them into the hooks using a Transfer Tool.
5. Align the working needles in B position and unravel the incomplete row referring to page 99.

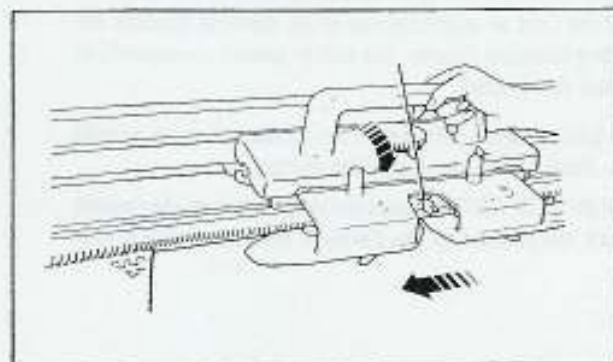

6. With the top of the Carriage up, pass the Carriage to the side with the yarn end. Press down the top of the Carriage and continue to knit.

If the Row Counter, the Knit Contour (Radar) and/or the Pattern Card is/are in use, refer to "If incorrectly knitted..." on page 106 & 107 before continuing to knit.

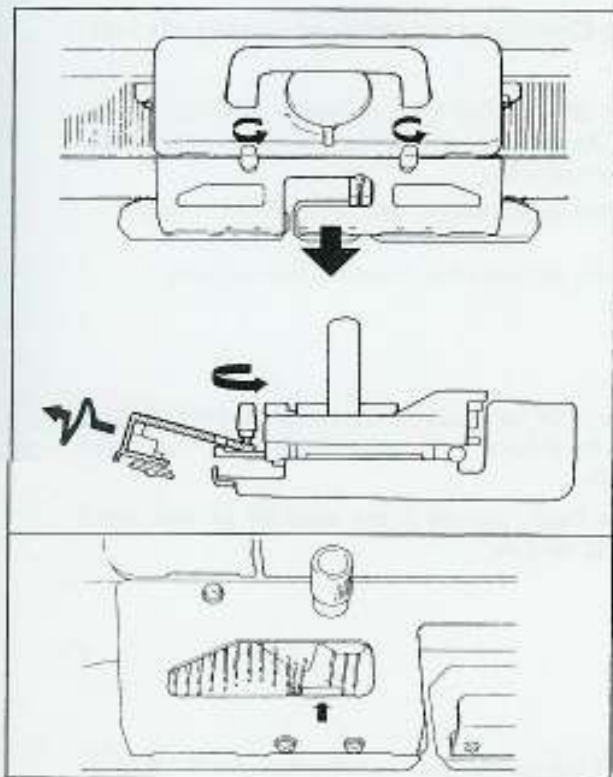

If the Lace Carriage has jammed...

DO NOT FORCE THE CARRIAGE.

1. Remove the yarn from the Yarn Feeder, and loosen the Arm Nuts.
2. Lift up the front of the Arm, and carefully remove it from the needles by moving it up and down.

If the hooks of the needles are caught in the Arm, carefully remove them using a Transfer Tool.

3. Remove the Arm from the Carriage.

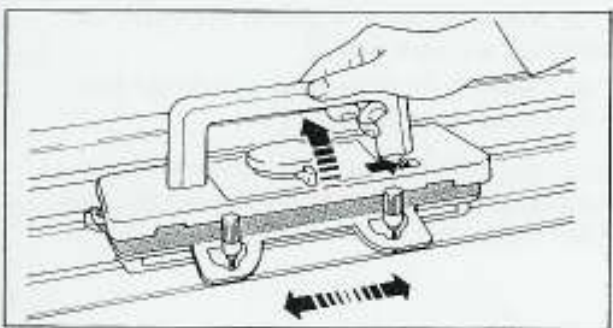

4. Push the Release Lever to lift up the top of the Carriage. Move the Carriage in the direction it was going, until it is clear of the working needles.

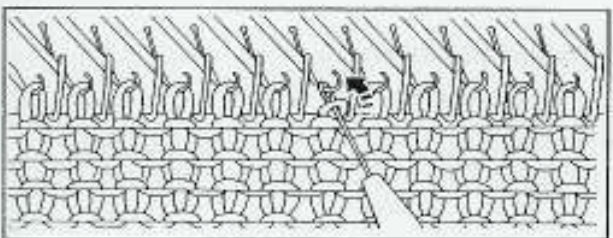

5. Check the stitches, and if stitches have moved behind the latches, replace them into the hooks using a Transfer Tool.
6. Align the working needles in B position and unravel the incomplete row referring to page 99.

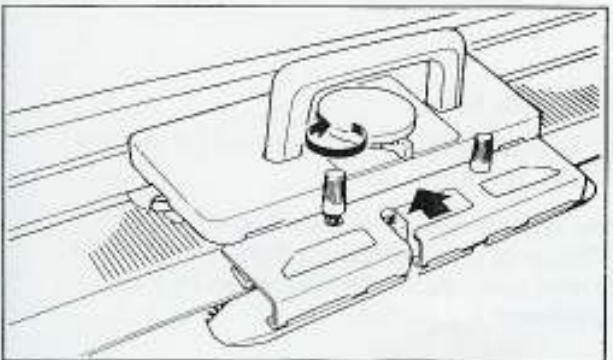

7. With the top of the Carriage up, pass it to the side with the yarn end. Press down the Carriage, and continue to knit.

If the Row Counter, the Knit Contour (Radar) and/or the Pattern Card is/are in use, refer to "If incorrectly knitted..." on page 106 & 107 before continuing to knit.

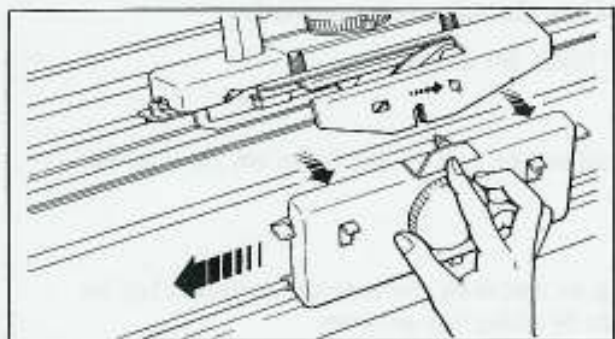

If the Carriage has jammed during rib knitting...

1. By pushing the Link Knob, disconnect the Ribber Carriage from the Arm and tilt it towards you, then move it to either end of the needle bed.

DO NOT PUSH OR PULL THE CARRIAGE BY FORCE.

2. Remove the Ribber Arm from the Standard Carriage.

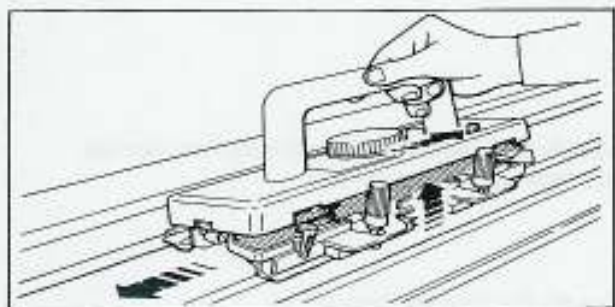

3. Lift open the Carriage by pushing the Release Lever, and move it in the direction it was going, until it clears the working needles.

If the Point Cams are in use, move the Carriage until it passes the Cam.

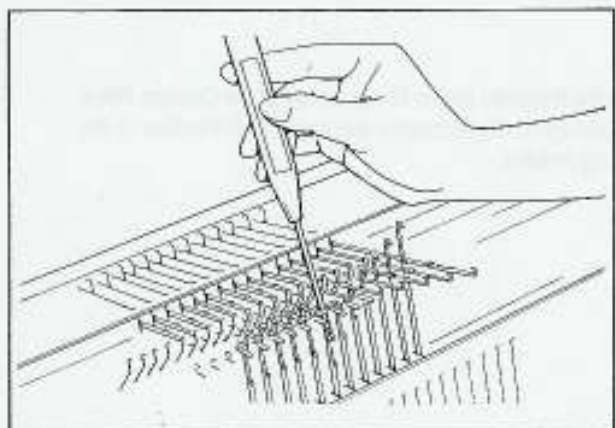

4. Check the stitches, and if stitches have moved behind the latches, replace them into the hooks using a Transfer Tool.

5. Align the working needles in B position and unravel the incomplete row referring to page 97.

6. Pass the Carriage to the side with the yarn end and press down the Carriage to continue knitting.

If the Row Counter, the Knit Contour (Radar) and/or the Pattern Card is/are in use, refer to "If incorrectly knitted..." on pages 106 & 107 before knitting again.

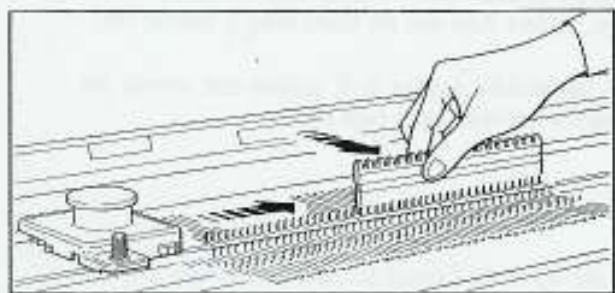

If P Carriage has jammed...

If it jammed on the Knitter...

Regardless of direction in which you are moving P Carriage, remove it and push all the needles to D position, then move P Carriage from the left to the right.

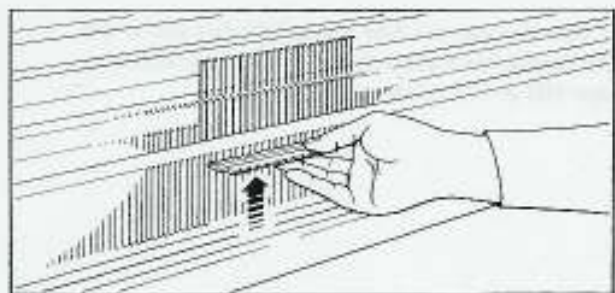

If it jammed on the Ribber...

Remove P Carriage and push all the needles to D position using Needle Pusher, then knit the next row.

If you have failed to align needles into C position for cast-on using P Carriage, push all the needles to D position and move P Carriage twice across the needles starting from right side. (Needles will align in C position.)

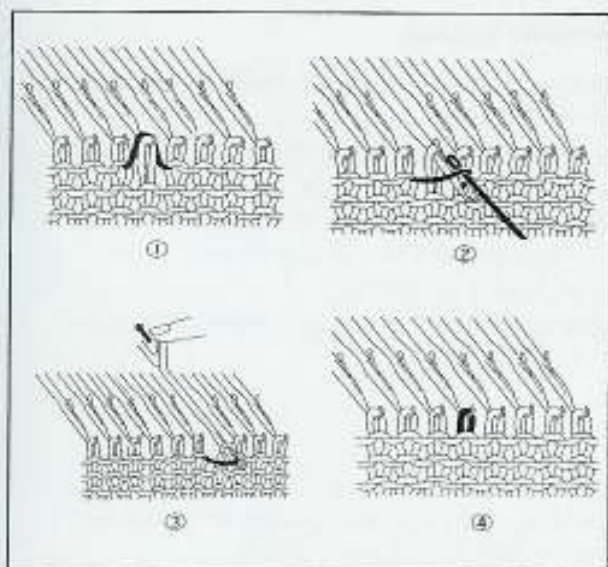

If a stitch has dropped during knitting on the Knitter...

1. Insert a One-Eye Transfer Tool into a stitch below the dropped stitch and replace it into needle hook together with loose yarn.
2. Slowly pull the needle out until the stitch is behind the open latch leaving the loose yarn in the hook.
3. Push the needle back so the latch will close and the stitch behind will slide over the hook reforming a stitch as illustrated.

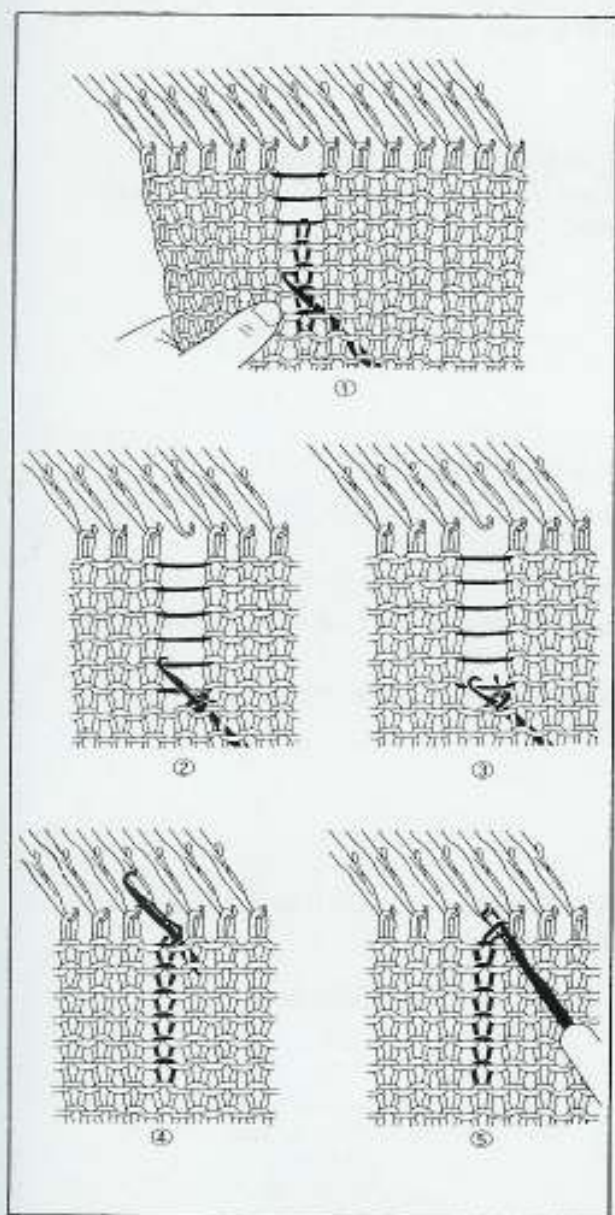

IN CASE A STITCH HAS DROPPED AND RUN DOWN FOR SEVERAL ROWS:

1. Insert a Tappet into the stitch a few rows below the dropped stitch, from the side away from you. Unravel the stitches down to the Tappet Tool.

Hint With the other hand, pull the fabric downwards. This makes unravelling easier.

2. Push the Tappet Tool toward you so the stitch moves behind the open latch. Catch the yarn crossing above into the hook.
3. By pulling the Tappet Tool backwards, the latch will close and the loose yarn will be trapped in the hook.
4. Continue pulling and the old stitch will slide over the closed latch forming a new stitch in the hook.
5. Repeat this operation up to the top.
6. Place the top stitch onto the needle hook.

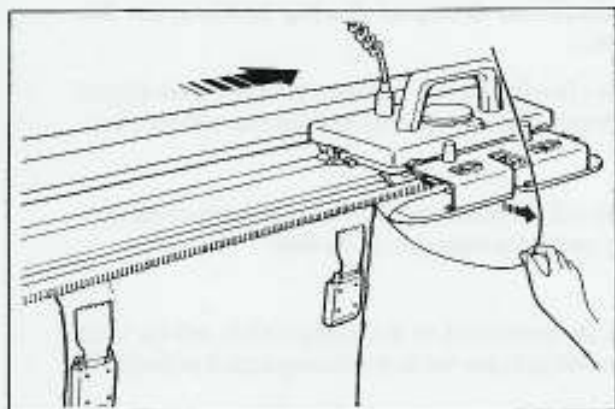

If incorrectly knitted...

Have the Carriage clear of the working needles and remove the yarn from the Yarn Feeder.

Refer to page 99, and unravel the incorrectly knitted rows.

IN CASE OF USING PATTERN BUTTON 3:

If an odd number of rows are unravelled, unravel an extra row making the total unravelled rows an even number.

IN CASE OF DOUBLE JACQUARD:

If the yarn end is at the left side unravel an additional row so that it comes to the right side.

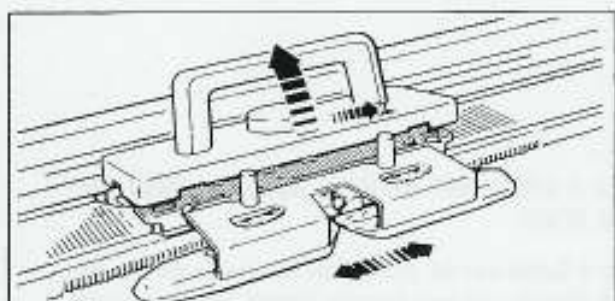

Replace the yarn into the Yarn Feeder, or if the Carriage is at the side opposite the yarn, pass it to the side with the yarn following the instruction given for each type of knitting.

IN CASE OF USING THE STANDARD CARRIAGE:

Push the Release Lever and lift up the Handle, then move the Carriage to the same side as the yarn.

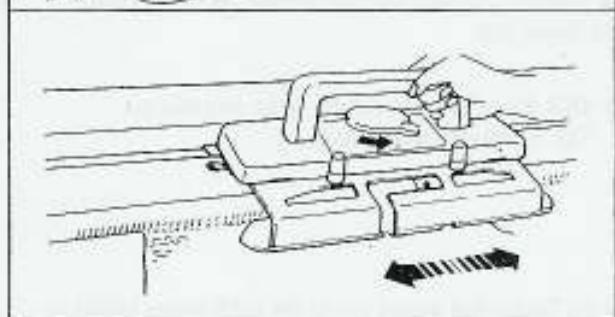

IN CASE OF USING THE LACE CARRIAGE:

Set the Cam Lever to "N", and pass the Carriage to the same side as the yarn.

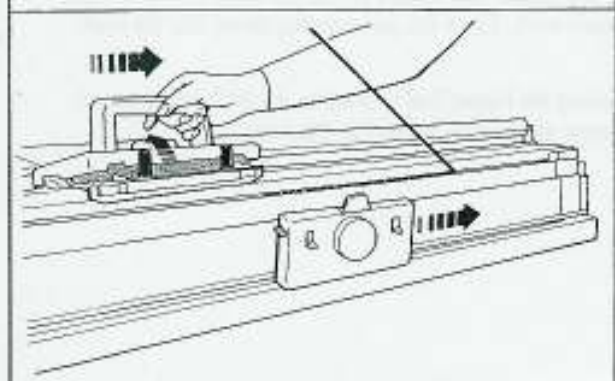

IN CASE OF USING THE RIBBER:

- (1) Disconnect Ribber Carriage from Arm and move it to yarn side while tilting Carriage.
- (2) Remove the Ribber Arm from the Standard Carriage.
- (3) Operate the Carriage Release Lever, and move the Carriage to the side of the yarn.
- (4) Connect the Ribber Carriage and Arm to the Standard Carriage.

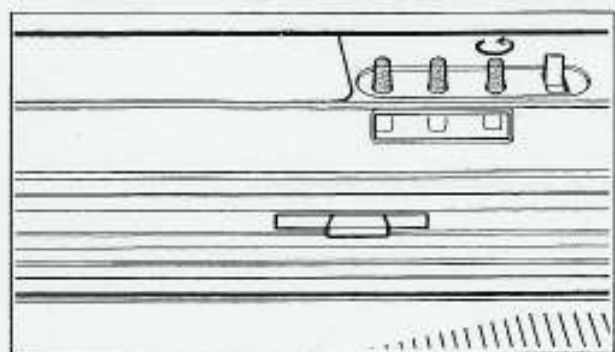

If the Row Counter is in use, return it by the same number as unravelled.

But if a Pattern Card is used, refer to the next page.

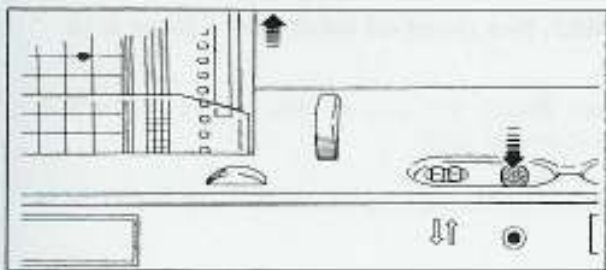

If a Pattern Card is in use, reset it in the following manner.

Push "ON" the Inspection Button.

(Light is on and the Pattern Card comes up 10 rows.)

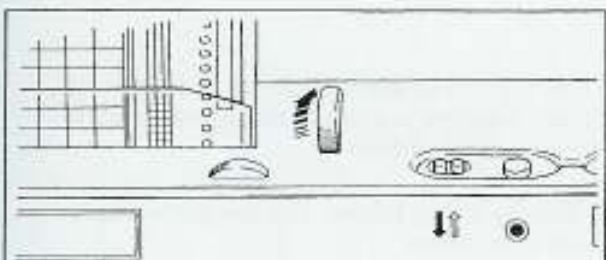

Return the Card by the same number of rows as unravelled in the direction opposite to that shown by the Feeding Direction Pointer.

A) When returning the Pattern Card, if you reach the first row of the pattern before returning the total rows required, turn the Card to the top row, and count the remaining rows from the top of the Pattern Card.

B) If the pattern is knitted in reverse from the top to the first row, count the rows in the direction reverse to that the Card advances.

Do not count the top or bottom end row twice.

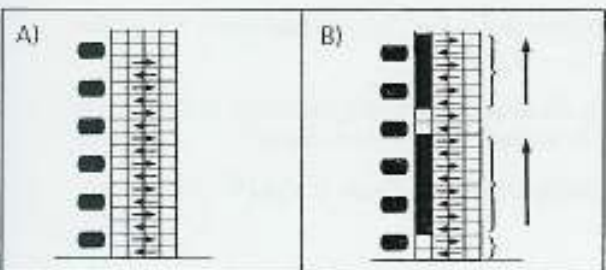
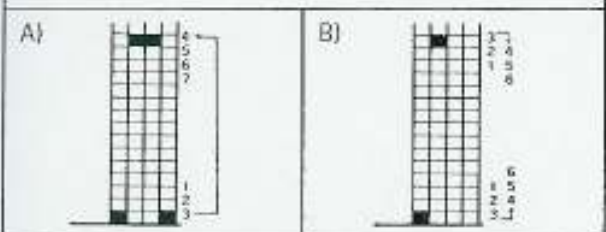

IN CASE OF USING PATTERN BUTTON 3:

Return the Card by half the number of rows unravelled.

IN CASE OF LACE STITCH:

Return the Pattern Card by the same number of rows as unravelled, but skipping the rows for transferring stitches which are marked black in the Notation Column.

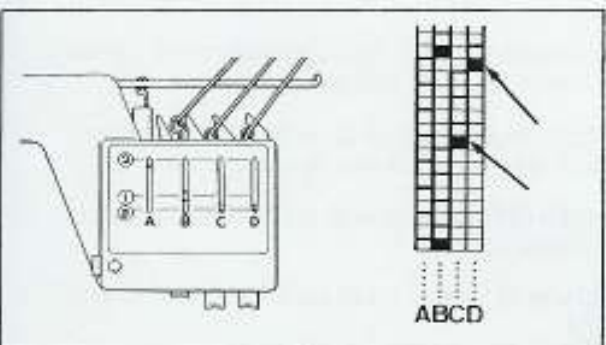

IN CASE OF DOUBLE JACQUARD:

With the inspection light on:

If an even number of rows unravelled, return the card half the number of rows as unravelled.

If an odd number of rows unravelled, return the card half the number of rows as unravelled minus one.

Since the two lights of Button 1 light up alternately on every two rows of knitting, reset the Button 1 according to the number of rows unravelled.

Re-arrange the Holder Buttons of the Yarn Changer to correspond with the mark in the Notation Column.

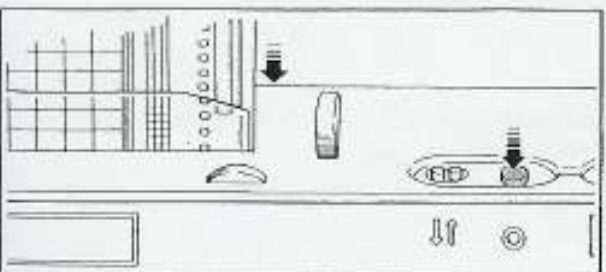

Push "OFF" the Inspection Button. (The Pattern Card is fed downwards by 10 rows and the row to be knitted is memorized.) Continue knitting.

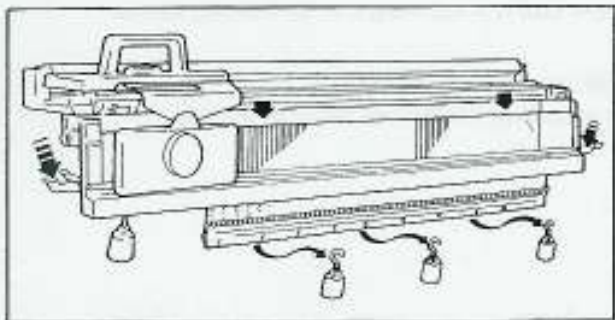

If a stitch has dropped when the Ribber is in use...

1. Remove Weights from Cast-on Comb as they may cause dropped stitches to run.
2. Depress Drop Lever and bring down Ribber to middle position.
3. With Hook Tool, pick up dropped stitch and place it back on needle hook. Then reform stitches by moving needle back and forth or by using Tappet Tool.
4. Raise Ribber to original position, hook Weights on Cast-on Comb and align needles.

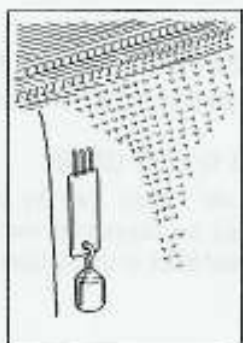
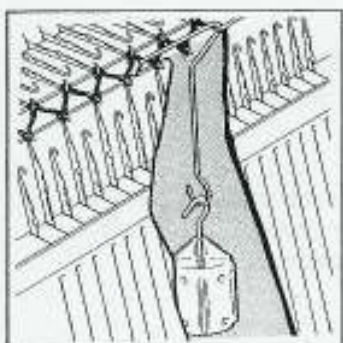
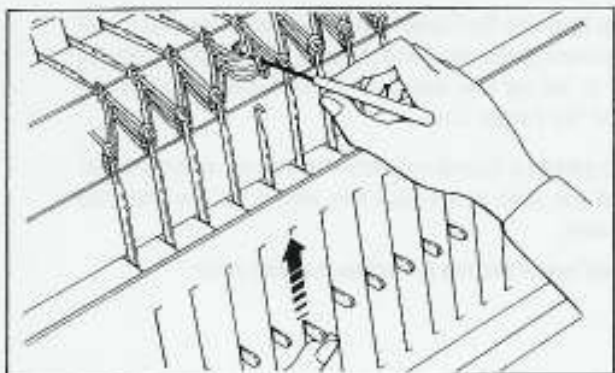

If stitches float when the Ribber is in use...

If edge stitches tend to float, suspend Edge Weight and advance it every 10—15 rows.

If stitches of half length of knitting float, check to see if Cast-on Comb with Weights is suspended horizontally.

Use of Hanger Comb with Weight is also effective.

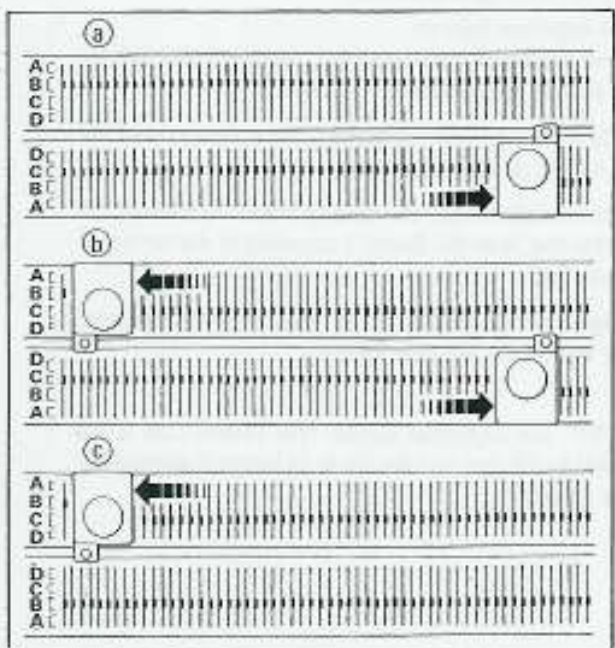

When stitches on full length float, push needles to C position using P Carriage (without P Presser) and knit.

In case of circular knitting, push up needles to D position either on knitter or ribber, to whichever is to be knitted next.

In case of pin tuck knitting, push up Ribber needles for rows of pin tuck knitting. (a)

In case of wide rib, push up Knitter and Ribber needles on every row. (b)

Firstly, slide P Carriage from the left to the right on Ribber, and secondly slide P Carriage from the right to the left on Knitter.

In case of variation swing, push up needles on the bed with most needles. (a) or (c)

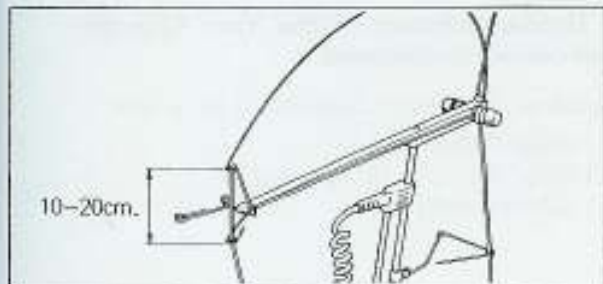

If the end stitches are not stable or if the Carriage is heavy to operate...

Check the following points.

- Is the yarn coming out freely from the inside of yarn ball. (P.2)
- Is the yarn threaded into the Auto-Tension correctly. (P.8)
- Is the machine lubricated properly. (P.112)

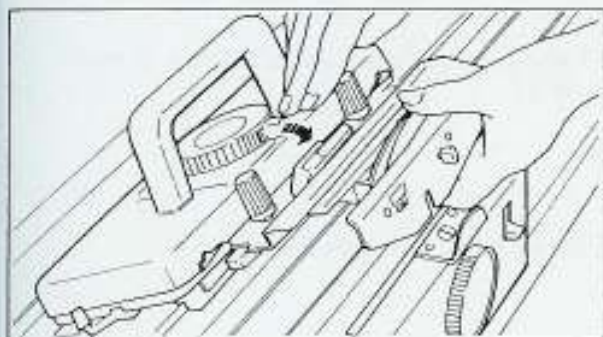

If the Ribber Arm does not fit on the Standard Carriage properly...

1. Check to see if the top of the Standard Carriage closed properly. The top of the Carriage must be down.

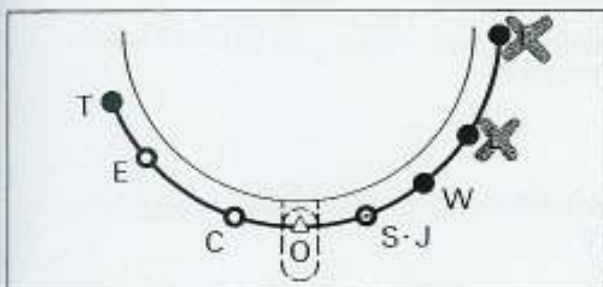

2. Check the setting of the Cam Lever. It should be set at "0" before mounting the Ribber Arm, never at F (FAIR ISLE) or L (PUNCH LACE).

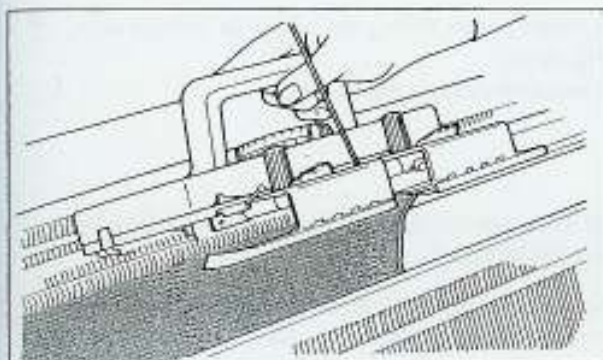

If you knit with the Knitter only with the Ribber connected...

1. Disconnect Ribber Arm and Carriage from Knitter Carriage.
2. Lower Ribber to its fullest extent by pushing down Drop Levers twice.
3. Fit Knitter Arm and start knitting.

To use the Lace Carriage when the Ribber is connected, refer to page 35, for special precautions.

Type of knitting	2-Colour A.T.	4-Colour A.T.
Stockinet (medium yarn)		
K1.P1. rib (medium yarn)		

If you use 4-Colour Auto-Tension for knitting other than double jacquard...

The tension springs of the Four-colour Auto-Tension are stronger than those on the Two-colour Auto-Tension. If you use the Four-colour Auto-Tension for normal knittings, set the Tension Dial and Stitch Dial as follows.

- Tension Dial..... Refer to page 8.
- Stitch Dial..... Use 1 number larger.

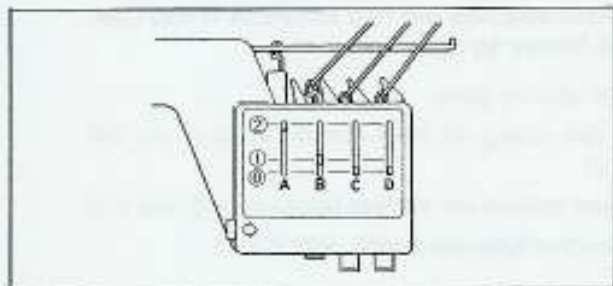

If the Holder Buttons of the Yarn Changer were erroneously operated...

Correct positions of the Holders while knitting are as below.

- ②.....1 Holder (Knitting yarn)
- ①.....1 Holder (Yarn to be changed next)
- ③.....2 Holders (Resting yarns)

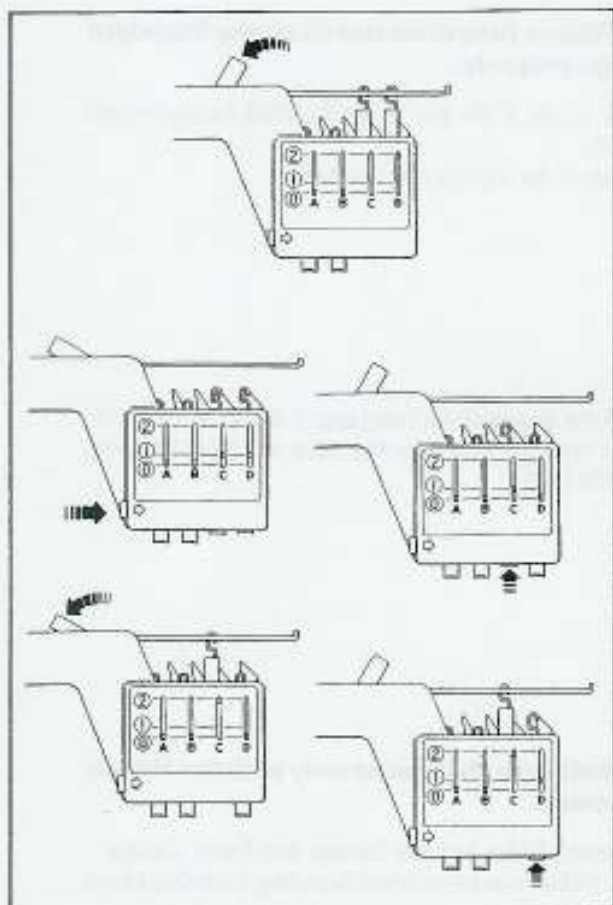

In case of more than two Holders positioned in ②.

- (1) Push Feeding Lever to the left, and the Holders in ② move back into ①.

- (2) Push Release Button, and all the Holders align in

- (3) Push the Holder Button to set to ① the holder for the yarn in the Yarn Feeder.

- (4) Push Feeding Lever to the left to push the Holder from ① into ②.

- (5) Push Holder Button holding the yarn to be changed next, from ③ into ①. Then rearrange yarns on the Holders.

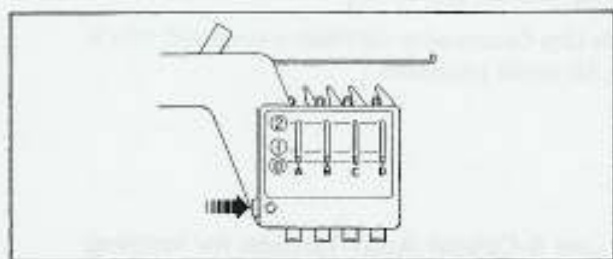

In case of more than two Holders positioned in ①, follow the above steps (2) through (5).

To repack Yarn Changer, set all the Holders at ③ by operating as instructed in the above steps (1)–(2).

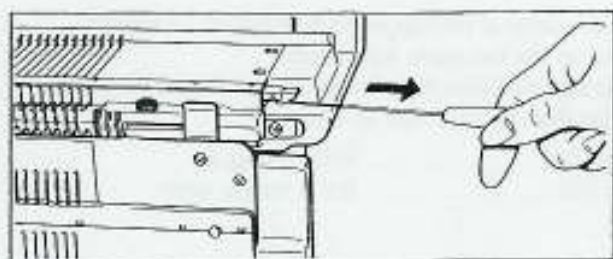

If the Yarn Changer is stuck on the Needle Bed...

Pull out Needle Retainer toward right by 2—3cm. using Hook Tool, then loosen Securing Wheel until it stops.

If a needle has been damaged...

Using a pencil or a screw driver, push the Needle Retainer in either direction.

If the Yarn Separators are in use, remove them before removing the Needle Retainer.

Pull the Needle Retainer toward one end until it clears the needle to be replaced.

If a stitch is hooked on the needle, use the Tappet Tool to pick up the stitch and transfer it to the new needle.

Push the damaged needles to D position. Close the latch and press the needle down. The shank will come out of the needle bed.

Lift up the needle by holding the shank and pull it to remove from the Needle Bed.

To replace a new needle (see NOTE), open its latch and slide it into the Needle Bed groove until the hook comes out of the front opening of the Needle Bed. Push the needle back to A position by holding the butt.

Insert the Needle Retainer back into the Needle Bed by pushing the protruding end. To insert the Needle Retainer, press the floated needles at the front edge of the Needle Bed using the Needle Pusher. If a stitch is held on a Transfer Tool, replace it on the new needle.

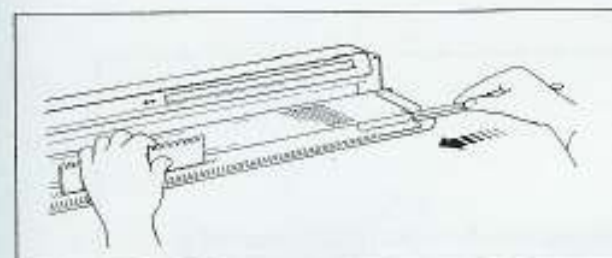
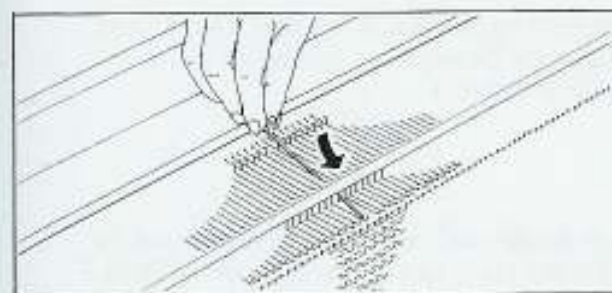
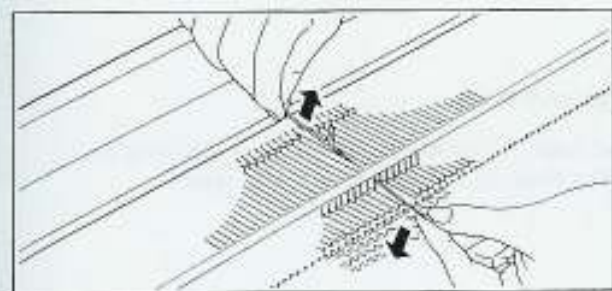
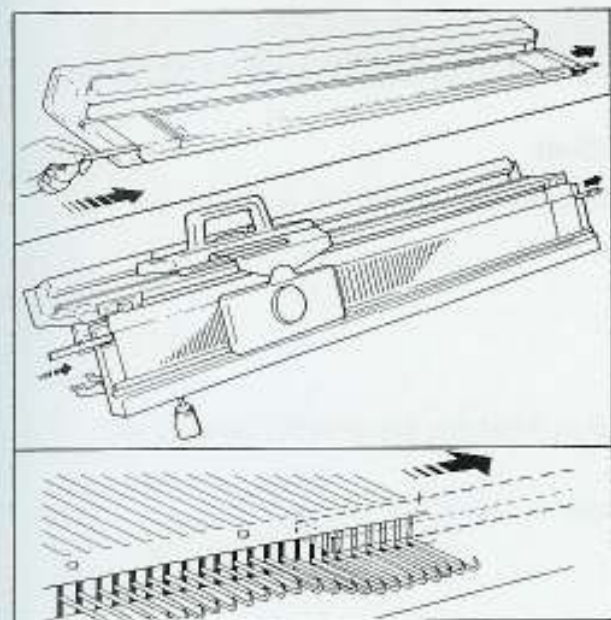

NOTE:
When replacing needles, use only needles specifically for this machine.

MAINTAINING THE MACHINE

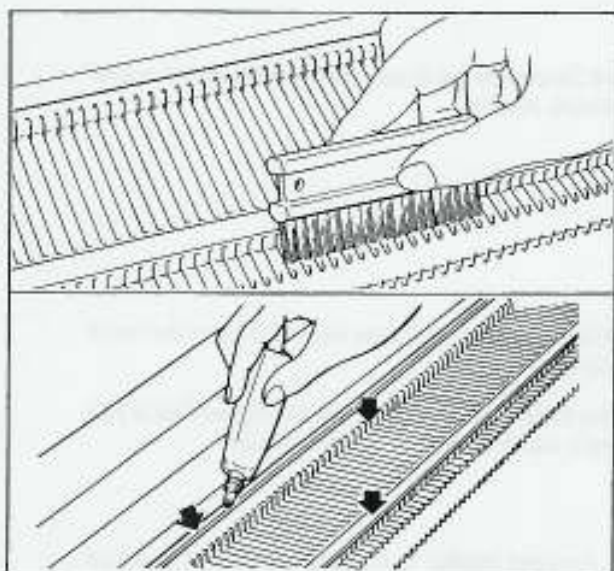

Needle Bed

With Cleaning Brush remove lint or dust from Needle Bed.

Apply oil along the rail, front guide of the Needle Bed and needle butts

(Do not apply excessive oil.)

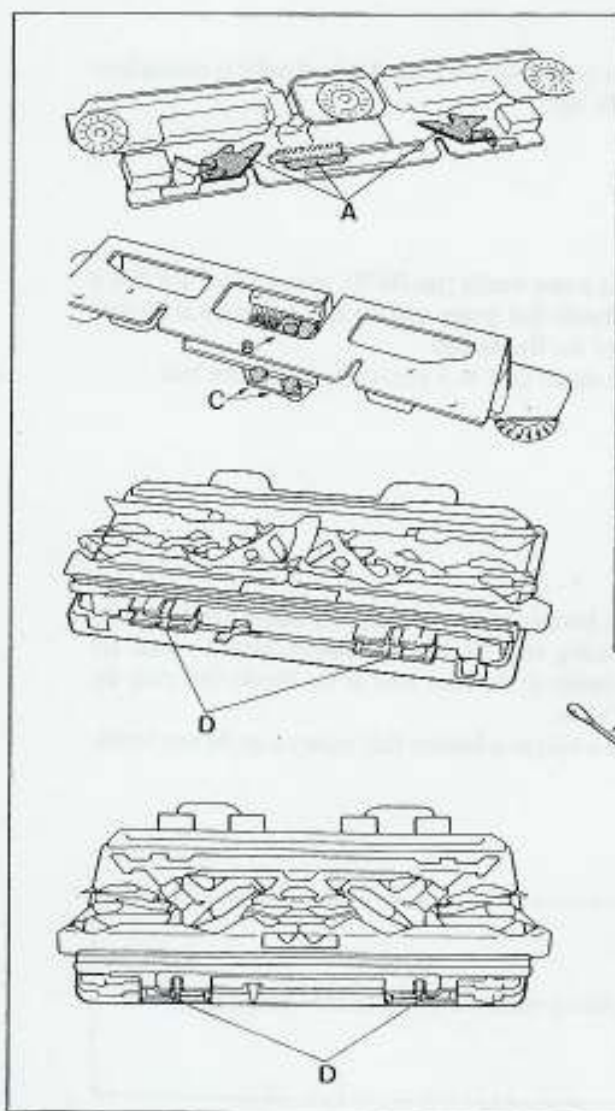

Carriage and Arm

The metal parts "A", on the back of the Lace Arm must be handled very carefully, do not bend or scratch them.

Remove any lints from the Rollers "B" and Yarn Feeder "C" of the Lace Arm using the Cleaning Brush, and from the Sensors "D" using the Sensor Cleaner "E".

With an oil damped cloth, apply oil to the underside of the Standard Carriage (a), Lace Carriage (b) and Ribber Carriage (c).

DRAWING A PATTERN ON THE DESIGN CARD

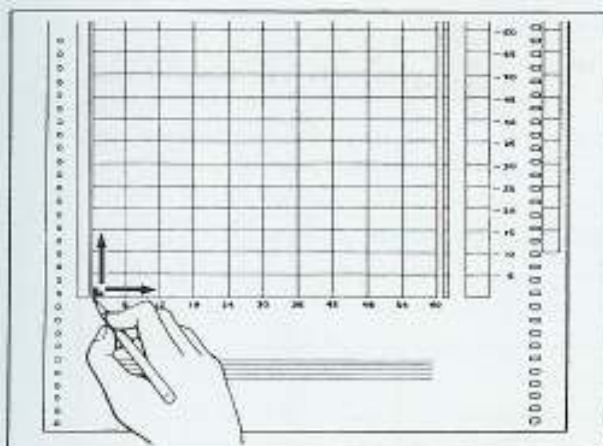

Draw your own pattern or trace a pattern from the pattern book onto the Design Card supplied with the Pattern Card set using a Design Pencil.

Fill up the sections neatly for the pattern taking the following precautions.

Start filling the sections from the bottom left corner.

Work on a solid hard surface.

Darkness of each section must be even.

To avoid failure in drawing, make a rough sketch and trace it onto the Design Card.

Incorrect drawing can be erased using a plastic eraser.

* In a picture or a letter image, draw the entire area rather than section by section. (Three-star Pencil is recommended.)

* For geometric pattern, fill up sections one by one with care. (One-star pencil is recommended.)

Take care when drawing a pattern design for the following type of knitting.

In Single Motif:

As the Button 1 is used with its left light on, draw the area to be knitted in single motif.

In Tuck or Slip stitch pattern:

As the Button 1 is used with its right light on, draw the area to be tucked or slipped.

Buzzer Column and Instruction Columns.

Put marks to correspond with the first and end row of the pattern as shown below.

Notation Columns

Mark with an ordinary pencil at the rows to change the yarns or to change the settings for knitting.

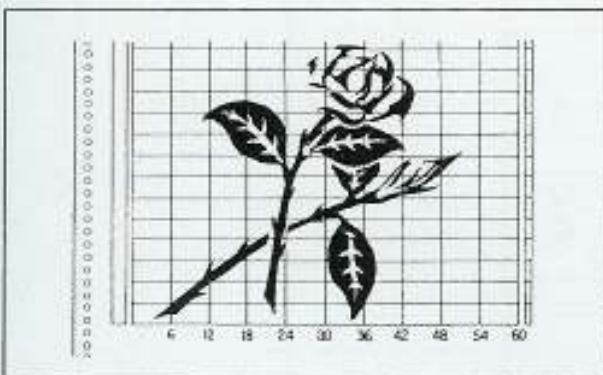
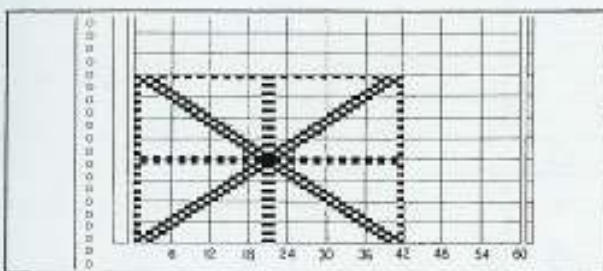

In case of knitting in the same direction continuously

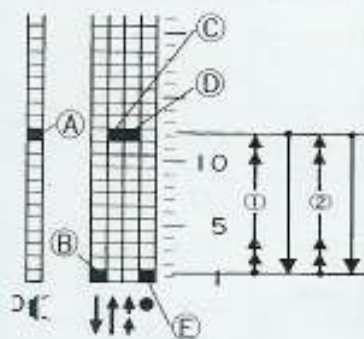

In case of knitting in both directions row by row

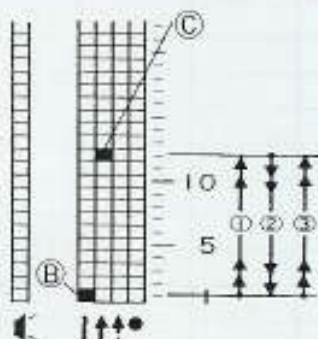

Markings on each column

- (A) Mark for colour change, or to alter machine settings.
- (B) Moves the Card downwards.
- (C) Changes the feeding direction. (The Card is fed upwards.)
- (D) Actuates quick motion.
- (E) Stops quick motion.

PATTERN AND STITCH TYPE POSSIBILITIES

The list below shows that each pattern can be used for various stitch types.

PATTERN NUMBER	KNIT-IN (FAIR ISLE)	TUCK STITCH	SLIP STITCH	WEAVING	PUNCH LACE	PIN TUCK	TUCK RIB	DRIVE LACE KNOTTING	MESH KNOTTING	PILE KNOTTING	DOUBLE JACQUARD
1	○	○	○	○	○						○
2	○		○	○	○						○
3	○	○	○	○	○						○
4	○	○	○	○	○		○				○
5	○	○	○	○	○		○				○
6	○	○	○		○		○				○
7	○										○
8	○				○						○
9	○				○						○
10	○				○						○
11	○				○						○
12	○										○
13	○										○
14	○										○
15	○										○
16	○	○	○		○		○				○
17	○	○	○		○		○				○
18	○	○	○	○	○						○
19	○	○	○		○		○				○
20	○		○		○						○
21	○	○	○	○	○						○
22	○		○		○						○
23	○	○	○	○	○		○				○
24	○	○	○		○						○
25	○	○	○		○		○				○
26	○		○		○		○				○
27	○			○	○						○
28	○		○		○						○
29	○		○	○	○						○
30	○			○	○						○
31	○					○					○
32	○					○					○
33	○					○					○
34	○				○	○					○
35		○			○			○			○
36		○			○			○			○
37		○			○			○			○
38		○			○			○			○
39									○	○	○
40									○	○	○
41									○	○	○
42	○										○
43	○										○
44	○										○
45	○										○

For the patterns for Lace Carriage, Pattern No. L—(1) through L—(14) are for Normal Lace, and the Pattern No. L—(15) through L—(20) are exclusively for Fashion Lace.