

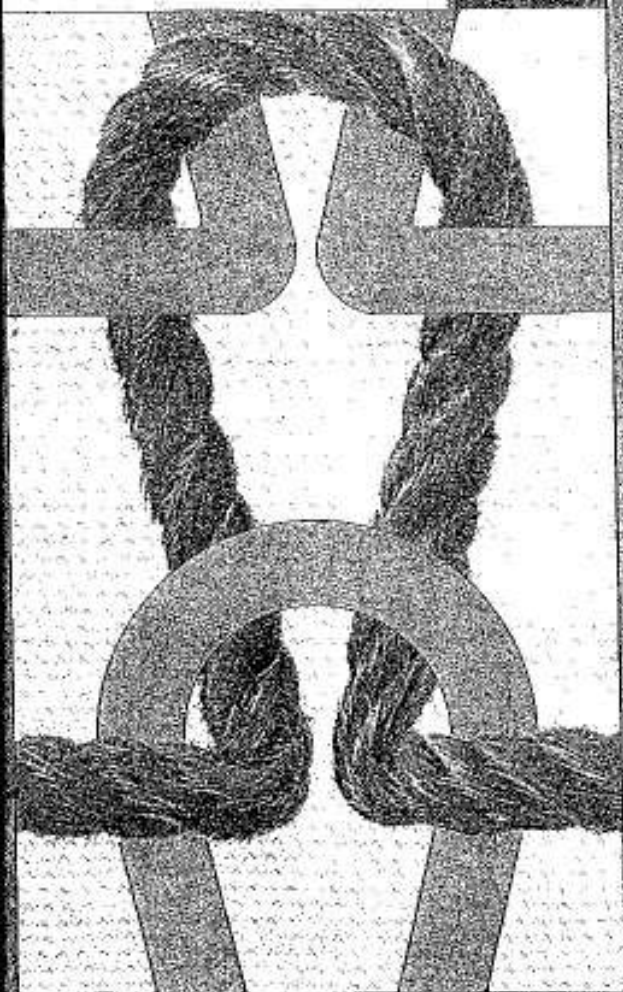

KNITTING MANUAL



MODEL 560



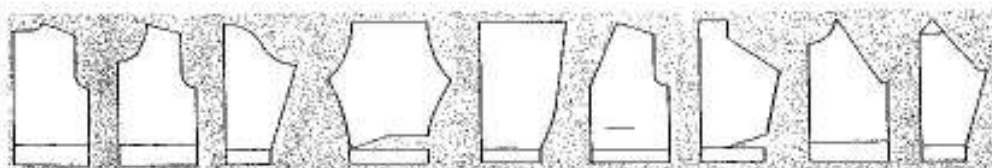

Getting to know how to knit garments...

With easy-to-follow method, this manual helps you obtain comprehensive knowledge of garment knitting.

This manual presents knitting procedure using the Pattern Papers on the Knit Contour, and a collection of necessary techniques which is convenient for your frequent reference. So keep this manual beside you while you are proceeding with garment knitting, and you will be able to expand your horizons of knitting by yourself with much fun.

This manual opens with **TAKING A TENSION GAUGE**, because it is the first and most important step to go into the pleasure of knitting and reach successful knitting result.

Follow this manual from the first page through to the end, and enrich your wardrobe with various knitted garments of your choice.



...till a garment is completed.

1 Select a pattern



19 different pattern styles are available to you.

2 Set up the machine



Refer to the Operation Manual.

3 Knit a tension swatch



The Gauge Scale helps you take a correct tension gauge.

4 Set the Knit Contour



Row number, Pattern Paper, Stitch Scale.

5 Knit pieces



6 Block out and press



7 Make up the garment



CONTENTS

	page
TAKING A TENSION GAUGE.....	1
PATTERN PAPER.....	7
SETTING THE KNIT CONTOUR.....	9
TO UNDERSTAND PRINCIPLES OF THE KNIT CONTOUR.....	13
KNITTING ON THE KNIT CONTOUR.....	15
IF A MISTAKE TAKES PLACE WHILE KNITTING.....	21
KNITTING TECHNIQUES – on the Knitter—.....	22
Increase.....	22
Decrease.....	24
Partial knitting.....	26
Holding Stitches.....	30
Cast off.....	32
Mock rib.....	33
Hemming.....	34
Trimming.....	35
Buttonhole.....	36
Joining.....	37
K1. P1. rib.....	38
Cable stitch.....	39
Garter stitch.....	39
Cord knitting.....	40
Pompon.....	40
KNITTING TECHNIQUES – with the Ribber –.....	41
Increase.....	41
Decrease.....	43
Partial knitting.....	45
Waste knitting.....	50
Buttonhole.....	51
KNITTING GUIDE.....	52
A-2 Lady's Cardigan.....	52
A-3 Lady's Raglan Sleeve Pullover.....	53
A-4 Lady's Skirt.....	54
A-5 Lady's Slacks.....	55
A-6 Lady's One-piece Dress.....	56
B-2 Man's Cardigan.....	57
B-3 Man's Raglan Sleeve Pullover.....	53
C-1 Child's Pullover.....	59
C-2 Child's Cardigan.....	52
C-3 Child's Raglan Sleeve Pullover.....	60
C-4 Child's Slacks.....	55
C-5 Child's Skirt.....	61
C-6 Child's Top.....	61
C-7 Child's Coat.....	63
C-8 Child's Brief.....	64
C-9 Leggings.....	65
C-10 Rompers.....	66
INDEX.....	68

TAKING A TENSION GAUGE

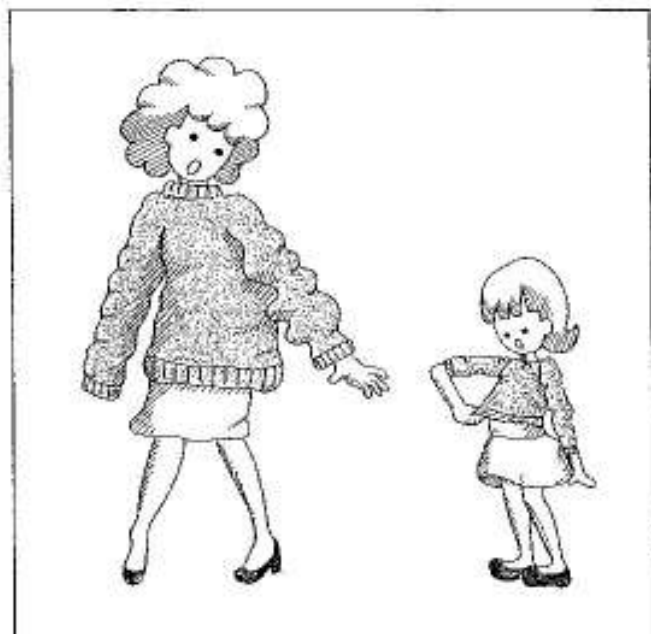

Tension Gauge

Your success in knitting greatly depends on taking a correct tension gauge, because knitted fabrics are affected by type of yarn and stitch. If this most important step is overlooked or ignored, you will never be able to expect your garment knitted to correct size.

Tension swatch

Tension swatch is a practical method to determine correct tension gauge for the yarn and stitch type you selected for knitting a garment.

With the yarn you selected, knit the tension swatch in the predetermined manner as described below.

To knit a tension swatch

Before knitting the tension swatch, try knitting till you obtain suitable Stitch Dial number for the selected yarn.

Then knit the swatch in the manner instructed below.

For the Lace Stitch Pattern and when a thick yarn or the Ribber is used, refer to pages 3 - 5.

The method set forth below is for knitting a tension swatch of stockinet, but if you knit the swatch in a pattern stitch using a Pattern Card, follow the additional instructions given after **[P]** mark as well.

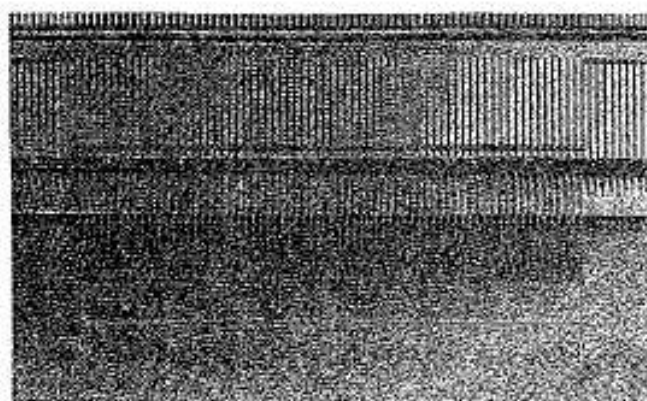
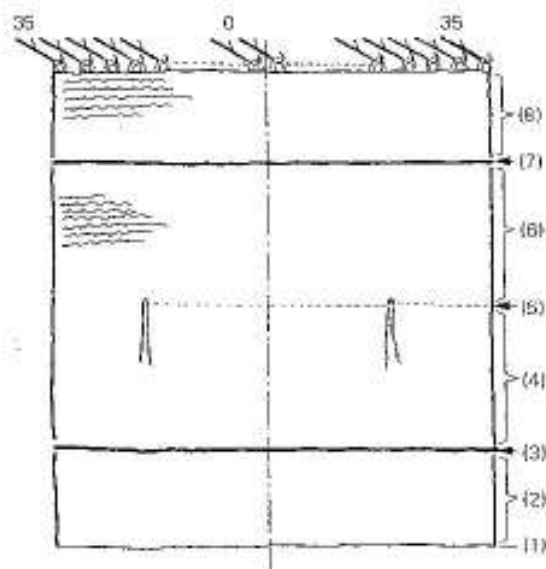

- (1) **[P]** Push "ON" the Inspection Button and set a selected Pattern Card. Set the Pattern Width Indicator.

Push up 35 needles on both sides of centre(0) on Needle Bed and cast on.

Knit several rows in stockinet continuously.

- [P]** Push "OFF" the Inspection Button.

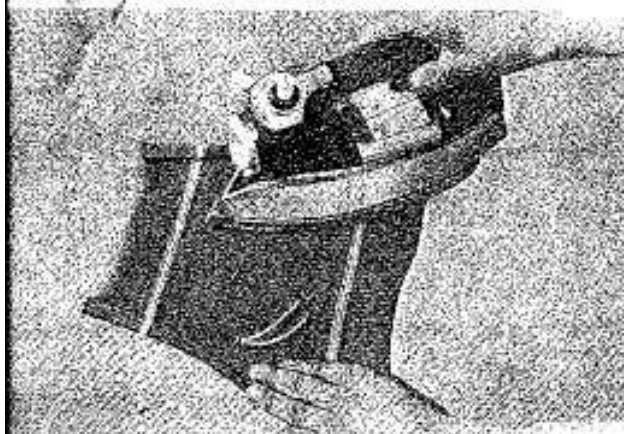
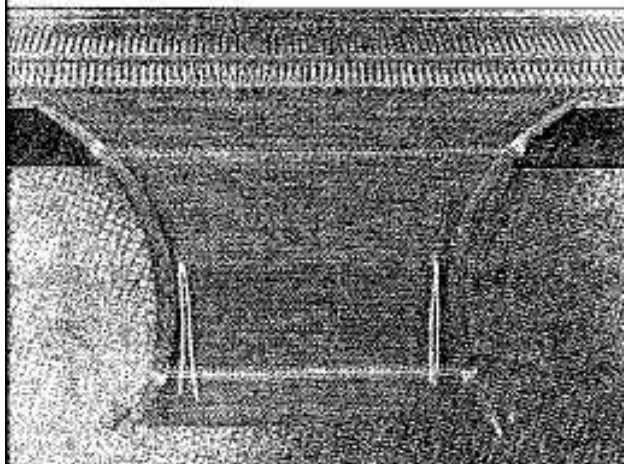
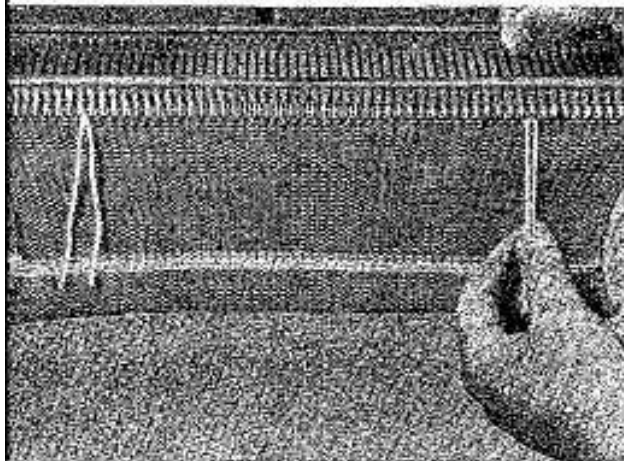
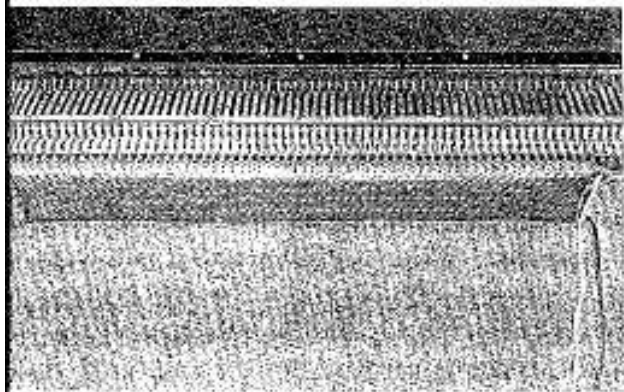

(2) In the selected stitch type, knit 20 rows.

P Push "ON" the Inspection Button.

(3) With a contrast yarn, knit 2 rows in stockinet.

P Push "OFF" the Inspection Button.

(4) In the selected stitch type, knit 30 rows.

(5) Push both 21st needles from centre(0) to D position.

With a piece of contrast yarn, knit them back to B position by hand.

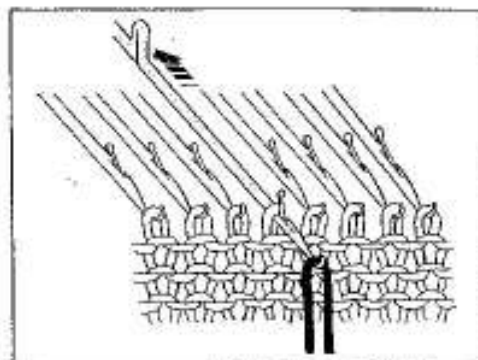

(6) Knit another 30 rows.

P Push "ON" the Inspection Button.

(7) With a contrast yarn, knit 2 rows in stockinet.

P Push "OFF" the Inspection Button.

(8) Knit another 20 rows.

TAKE NOTE OF THE STITCH DIAL NUMBER BEFORE REMOVING THE TENSION SWATCH FROM THE MACHINE.

(9) Remove the swatch from the machine and leave it for several hours to relax.

(10) Press the swatch lightly with a steam iron, or with an ordinary iron over a damp cloth.

To take a tension gauge, follow the instruction on page 6.

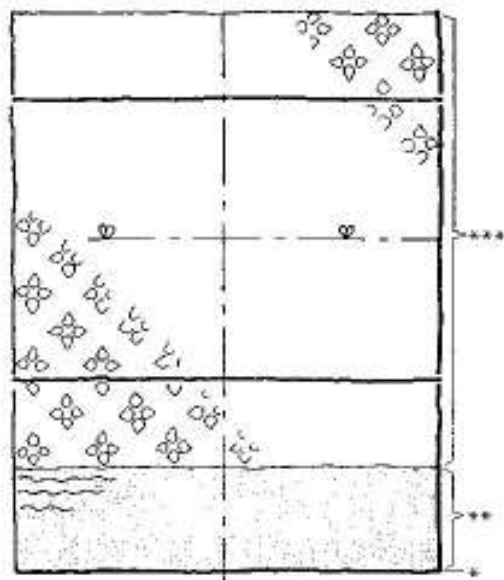

(Tension Swatch of Lace Stitch Pattern)

Take the following cares in knitting the tension swatch in lace stitch pattern.

- * Push up 35 needles on both sides of centre(0) to B position and cast on.
- ** Knit about 30 rows in stockinet ending at the right side of the fabric, Hook the Comb Weight and hang the Claw Weights.
- *** Push "OFF" the Inspection Button and knit the same number of rows as specified, putting the yarn marks.

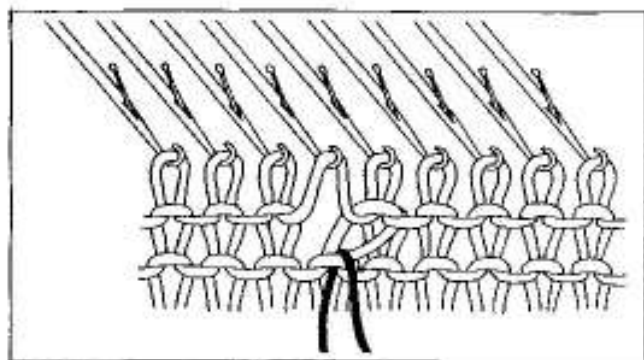

If the needle to have yarn mark has an incomplete loop, put the mark at the stitch on the row below.

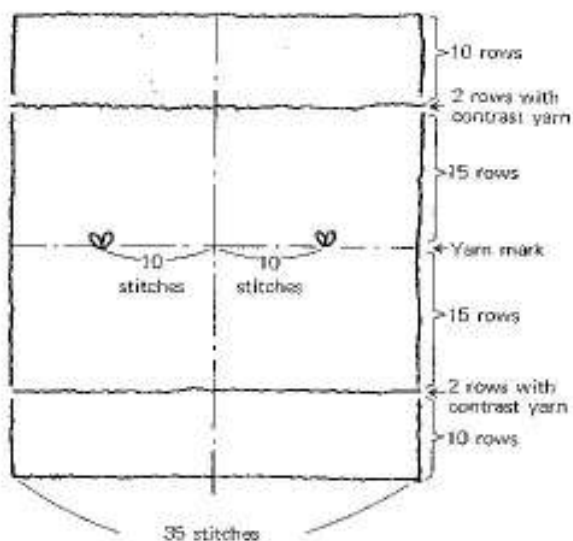

When a thick yarn is used...

Special cares are required in taking a tension gauge, and setting the Knit Contour, since the thick yarn may give the tension gauge less than 23 stitches by 30 rows which are the lowest limits of the Stitch Scale and the Row Number of the Knit Contour.

Knit the tension swatch in the manner instructed below.

- (1) Push up 35 needles on both sides of the centre(0) to B position, and push back every other needles to A position using the 1/1 Needle Pusher, so as the needles are arranged as shown below.

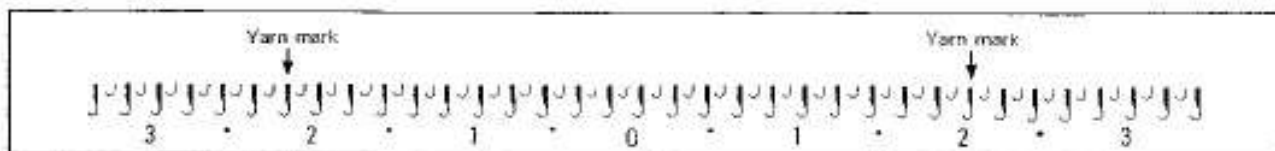

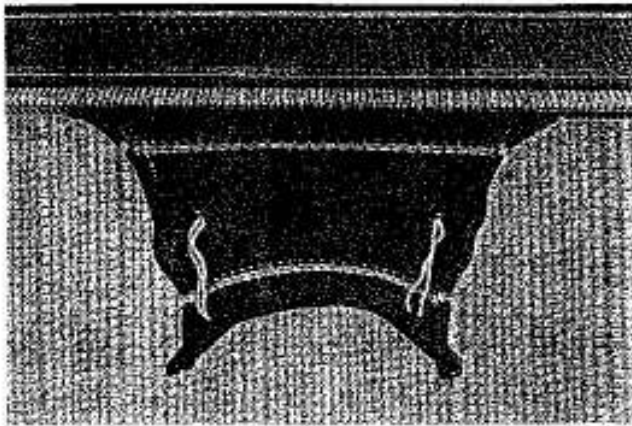
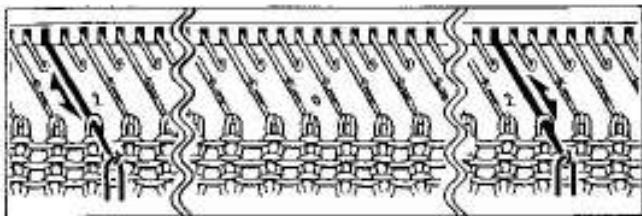

- (2) With the main yarn, cast on and knit continuously checking tension on the fabric, till you obtain suitable Stitch Dial number.
When you have obtained suitable Stitch Dial number, knit 10 rows.
- (3) With a contrast yarn, knit two rows.
- (4) With the main yarn, knit 15 rows.
- (5) Push 11th needles on both sides of the centre(0) in B position to D position. Lay a contrast yarn in the needle hook, and push them back into B position.
- (6) Knit another 15 rows continuously with the main yarn.
- (7) With the contrast yarn, knit 2 rows.
- (8) With the main yarn, knit another 10 rows.
- (9) Take note of the Stitch Dial Number.
- (10) Remove the swatch from the machine.

Leave the swatch for several hours to relax, and then take a tension gauge in the manner instructed on page 6.

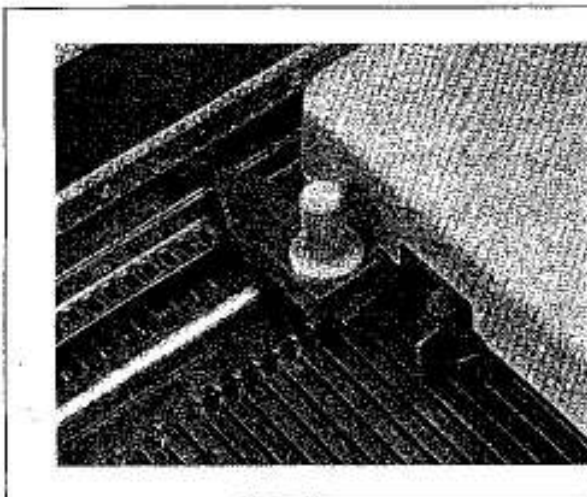

AUXILIARY FEEDING CAM

When using thick yarn and the Tension Gauge gives less rows than shown on the Row Number Dial, attach the AUXILIARY FEEDING CAM to the left side of the Carriage as shown.

By attaching the Cam on the Carriage the Pattern Paper is fed twice at each stroke of the Carriage, and the garment is knitted correctly to size.

* If erroneously knitted when the Auxiliary Cam is in use, see page 21.

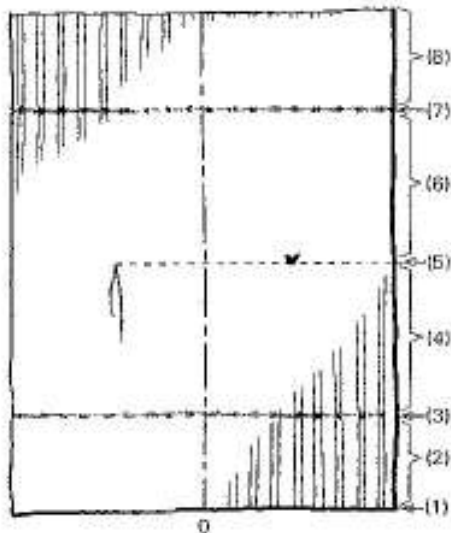

When the Ribber is used

When the Ribber is used for knitting a garment, stitches are knitted on both the Knitter and the Ribber, and in many cases, not all the needles within the range of fabric are used.

Therefore, the following instructions should be noted when knitting the tension swatch and also in taking a tension gauge.

- (1) Regardless of stitch type, always arrange needles within range of 35th needles on both sides of centre(0) on both beds as illustrated on the next page.

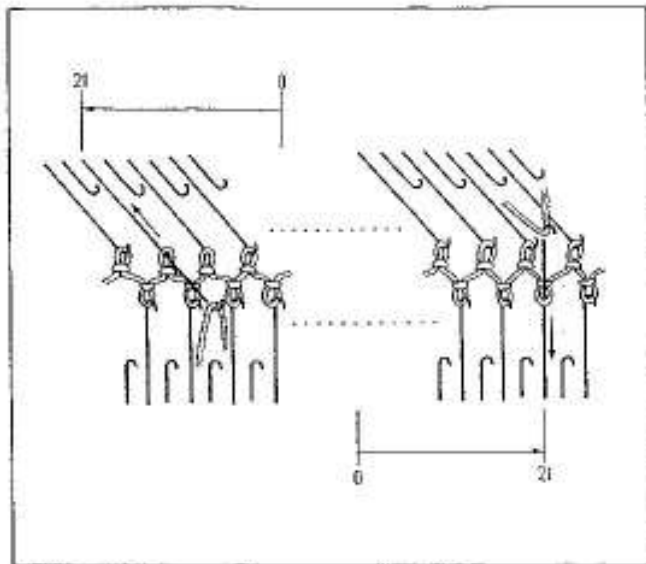
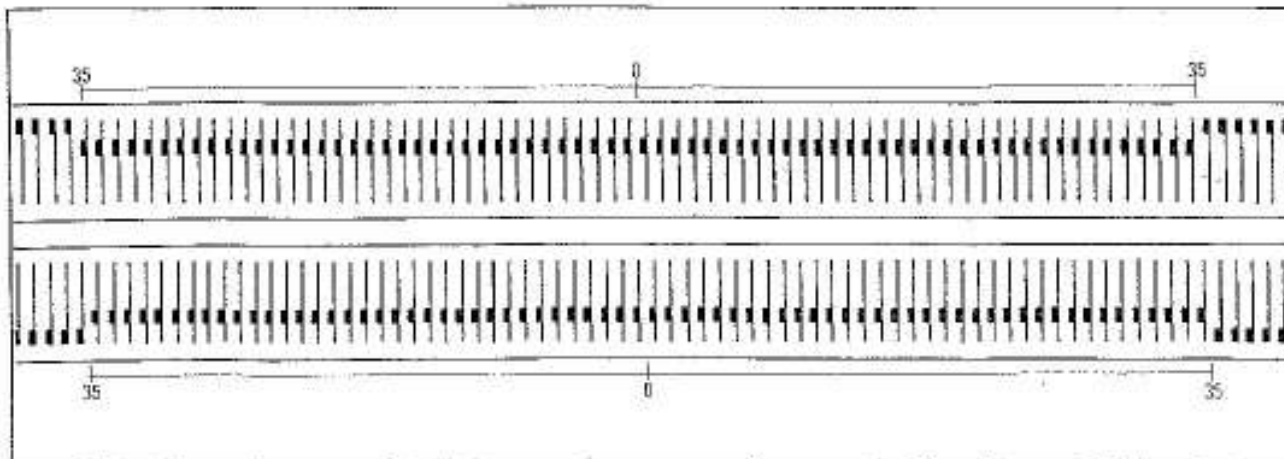

- (2) Cast on and knit 20 rows.
- (3) With a contrast yarn, knit 2 rows.
- (4) With main yarn, knit 30 rows.
- (5) Put yarn marks on the 21st needles on both sides of centre(0) on either Knitter or Ribber.
- (6) Knit 30 rows continuously.
- (7) With a contrast yarn, knit 2 rows.
- (8) With main yarn, knit 20 rows.
- (9) Remove the swatch from the machine.

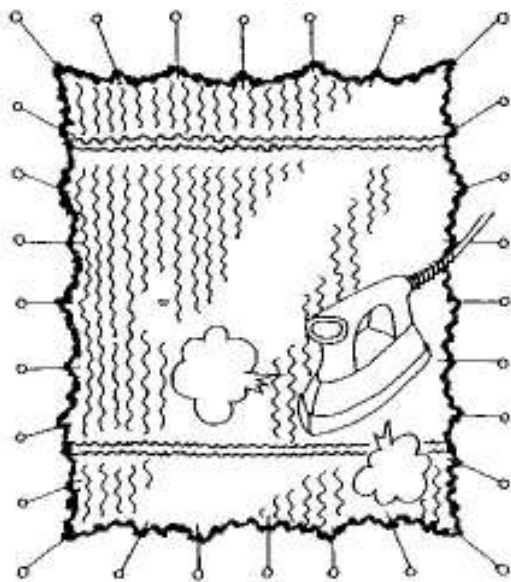

When the tension swatch is completed, remove it from the machine and leave it for several hours so that it can relax, then stretch the swatch as much as if it is worn, then pin it down.

Hold a steam iron close to the swatch and distribute its steam evenly over the swatch.

Allow the swatch to dry, take a tension gauge over it as it is pinned down, following the instruction on page 6.

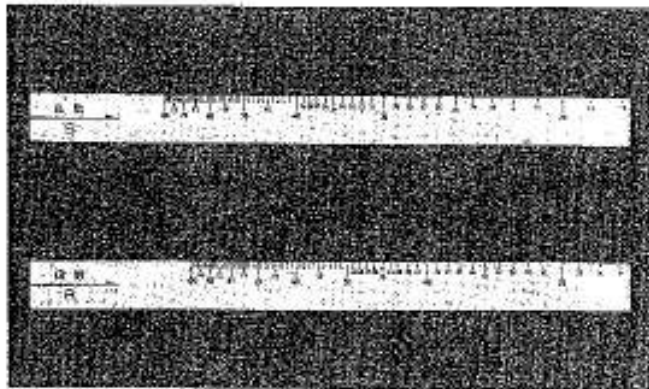

Gauge Scale

This scale is so designed to measure the length of 60 rows and the width of 40 stitches of the tension swatch, and designate them as so many stitches and rows per 10cm.

The scale is two sided. The side S is used for measuring stitches and the side R is for rows.

The photographs below show how the Gauge Scale is used.

How to measure the tension swatch

Stitch (Horizontal)

Place the Gauge Scale, with the "S" side up, onto the tension swatch so as the left end of the Scale is touching the inside of the stitch in a contrast yarn. Measure to the point of the other contrast stitch and the number which corresponds with this stitch.

The Scale should be read from the side indicated by the arrow, i.e. from the left side.

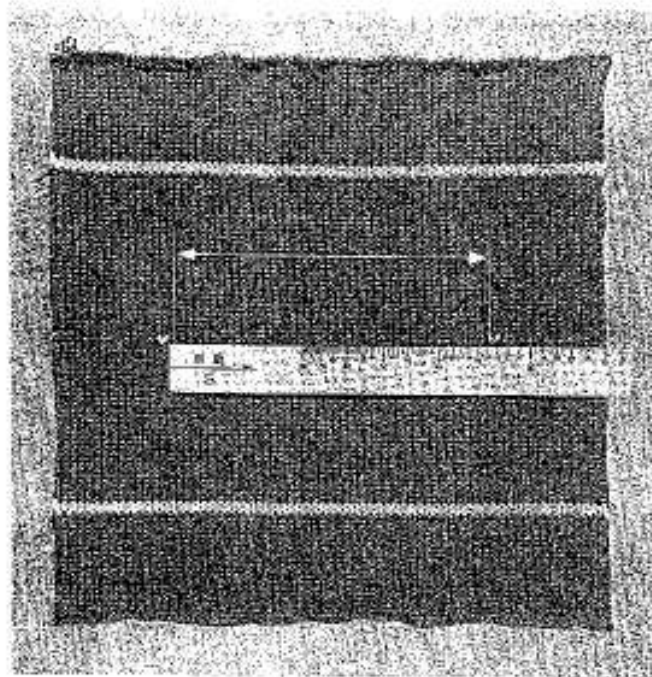

Row (Vertical)

Place the Gauge Scale, with the "R" side up, onto the tension swatch so as it covers the length in between the rows knitted in a contrast yarn. Measure this length and the number indicated on the Scale.

The Scale should be read from the side indicated by the arrow.

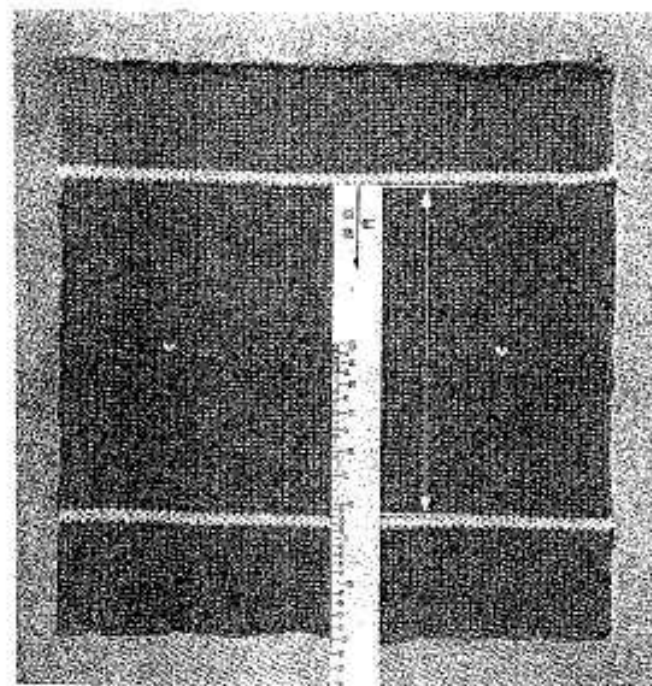

TAKE NOTE OF THE TENSION GAUGE.

(Number of stitches and rows)

PATTERN PAPER

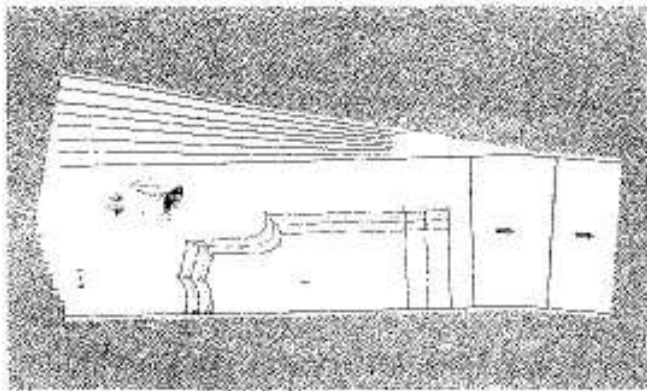

Pattern Paper Set

19 sheets of Pattern Paper representing 19 different pattern styles come with the machine incorporating the Knit Contour unit. Each pattern style is drawn to 1/2 scale with 2-5 graded sizes which are lettered A, B, C, D, & E from the smaller to larger sizes.

Selecting a pattern style

Of the 19 different pattern styles available to you, select the pattern of your choice. The table below shows the selection.

Pattern Style	Pattern Style No.	Page No.	Pattern Style	Pattern Style No.	Page No.
Lady's Pullover	A-1	1,2,3	Child's Pullover	C-1	25,26
Cardigan	A-2	4,5,6	Cardigan	C-2	27,28
Raglan Sleeve Pullover	A-3	7,8,9	Raglan Sleeve Pullover	C-3	29,30
Skirt	A-4	10	Slacks	C-4	31,32
Slacks	A-5	11,12	Skirt	C-5	33
One-piece Dress	A-6	13,14,15	Top	C-6	34
			Coat	C-7	35
Man's Pullover	B-1	16,17,18	Briefs	C-8	36
Cardigan	B-2	19,20,21	Leggings	C-9	37
Raglan Sleeve Pullover	B-3	22,23,24	Rompers	C-10	38

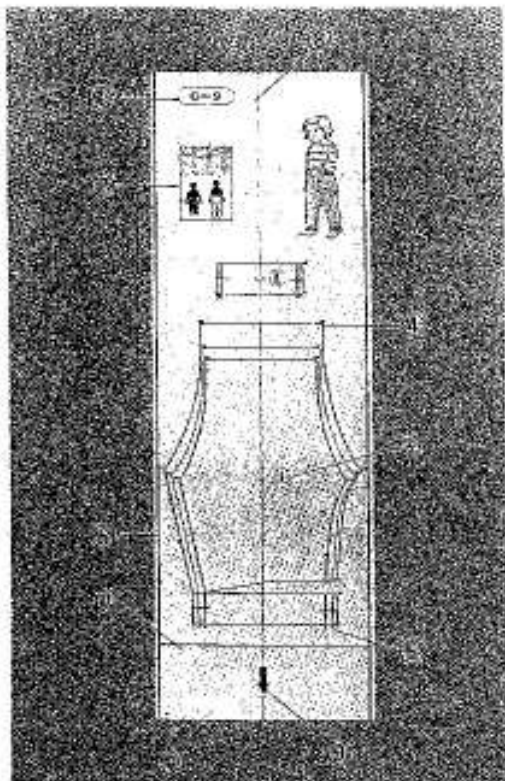

What are given on each pattern style.

- ① Pattern style number
- ② Measurement Table
- ③ Pattern piece number
- ④ Shaping sequence number
- ⑤ Pattern size (lettered A, B, C, D, E)
- ⑥ Vertical Standard Line
- ⑦ Horizontal Standard Line
- ⑧ Centre Line (to set the Pattern Paper in correct position)
- ⑨ Arrow mark (to set in the Knit Contour)
- ⑩ Page number

Selecting a pattern size

Measurement Table, shown opposite as an example, is given for each pattern style, and is consisted of two sections. One section (shaded line) shows body measurement graded into five sizes, and the other shows pattern measurements (measurements of finished garment) at each part graded into five sizes.

	A	B	C	D	E
a	81cm (32")	86cm (34")	91cm (36")	96cm (38")	101cm (40")
b	84 (33)	89 (35)	94 (37)	99 (39)	104 (41)
c	55.5 (21 $\frac{3}{4}$)	56.5 (22 $\frac{1}{4}$)	59 (23 $\frac{1}{4}$)	60 (23 $\frac{5}{8}$)	62 (24 $\frac{3}{8}$)
d	31.5 (12 $\frac{3}{8}$)	34.5 (13 $\frac{1}{2}$)	35.5 (14)	37.5 (14 $\frac{3}{4}$)	39 (15 $\frac{3}{8}$)
e	53 (20 $\frac{7}{8}$)	54.5 (21 $\frac{1}{2}$)	56 (22 $\frac{1}{8}$)	57 (22 $\frac{1}{2}$)	58 (22 $\frac{7}{8}$)

To select one size from those five sizes given, take your body measurement at the position indicated by the black figure in the Table, and select one size nearest to your requirements.

	Where to take measurements
① Bust	Over the fullest part of your bust and around back
② Waist	Around the natural waist curve line
③ Hip	Over the highest part of buttocks
④ Back width	From shoulder point to shoulder point
⑤ Length	From the first vertebra to the desired position
⑥ Sleeve length	From shoulder point to wrist

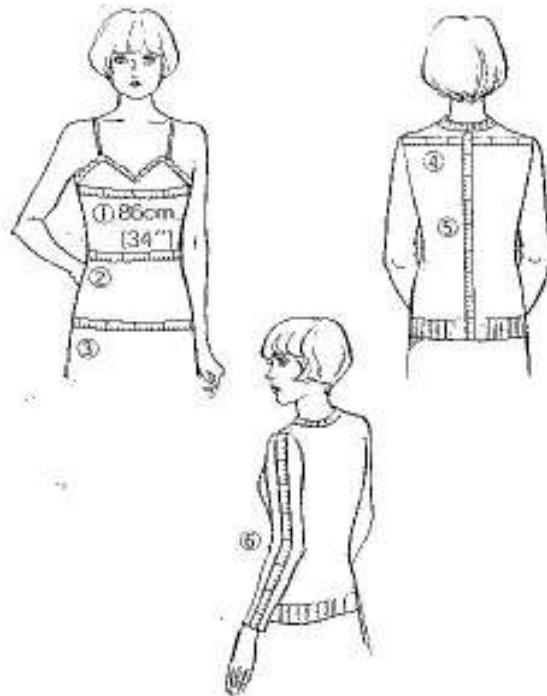

Example: If your body measurement (bust) is 86cm. (34"), select size B.

Take the measurement of the other parts of your body as illustrated opposite and listed below, and check them against the selected pattern size.

The pattern measurements include ease allowance.

	A	B	C	D	E
a	81cm (32")	86cm (34")	91cm (36")	96cm (38")	101cm (40")
b	84 (33)	89 (35)	94 (37)	99 (39)	104 (41)
c	55.5 (21 $\frac{3}{4}$)	56.5 (22 $\frac{1}{4}$)	59 (23 $\frac{1}{4}$)	60 (23 $\frac{5}{8}$)	62 (24 $\frac{3}{8}$)
d	31.5 (12 $\frac{3}{8}$)	34.5 (13 $\frac{1}{2}$)	35.5 (14)	37.5 (14 $\frac{3}{4}$)	39 (15 $\frac{3}{8}$)
e	53 (20 $\frac{7}{8}$)	54.5 (21 $\frac{1}{2}$)	56 (22 $\frac{1}{8}$)	57 (22 $\frac{1}{2}$)	58 (22 $\frac{7}{8}$)

If the body measurements are notably different from the pattern measurements, adjust the length and width of the pattern as shown.

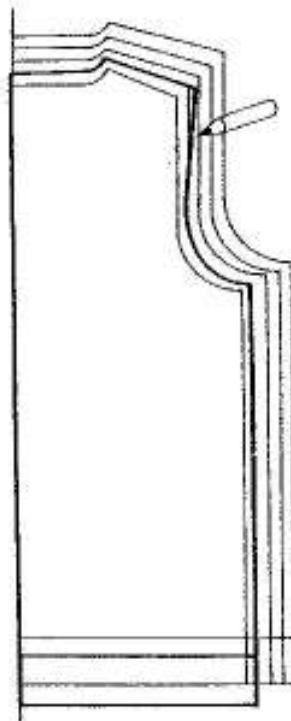

SETTING THE KNIT CONTOUR

The Knit Contour tells you where to cast on/cast off and the number of stitches to be increased/decreased while knitting a garment with the use of the Pattern Papers.

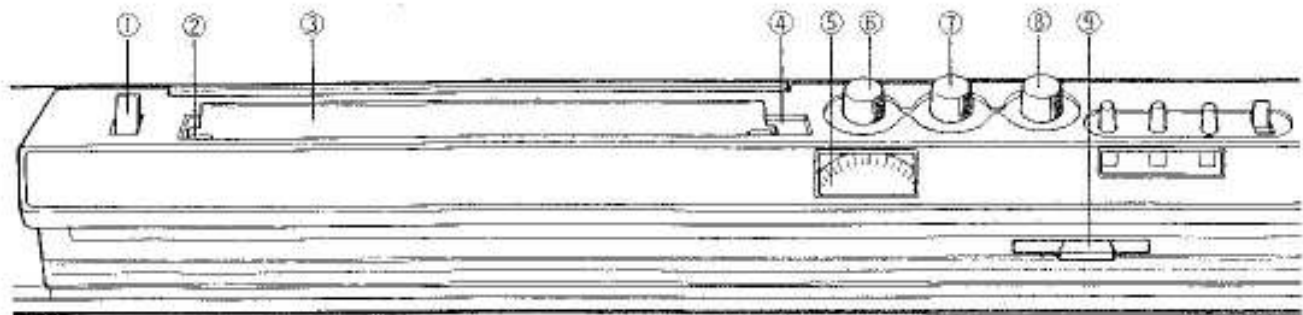

- ① **Paper Lever**
Used to open or close the Paper Holder.
- ② **Clip**
Holds a Stitch Scale.
- ③ **Paper Holder**
Holds the Pattern Paper against the roller while knitting.
- ④ **Paper Slit**
Insert the Pattern Paper into this slit.
- ⑤ **Row Number Window**
Set the selected row number at the red pointer in this window.

- ⑥ **Row Number Dial**
Adjust the row number by turning this dial.
- ⑦ **Feeding Dial**
Turn the Dial by hand to feed or return the Pattern Paper.
- ⑧ **Change Dial**
Provided with three positions, 0, 30-60 and 61-120, and used in setting the row number.
- ⑨ **Feed Lever**
Driven by the Carriage and advance the Pattern Paper.

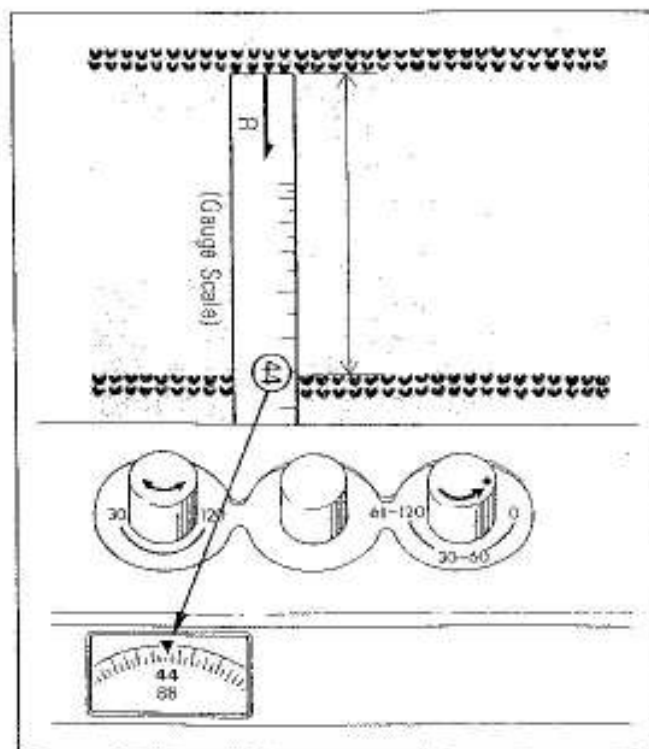

After you have succeeded in ascertaining the correct tension gauge, set the Knit Contour in the following order.

- i** Set the row number.
- ii** Set the Pattern Paper.
- iii** Select a Stitch Scale and set in place.

Set the row number

The number read on the Gauge Scale is the base for setting the row number.

- (1) Set the Change Dial to ◀.
- (2) Turn the Row Number Dial and adjust the same number as read on the Gauge Scale to the red pointer in the Row Number Window.

Important: Be sure to set the Change Dial to ◀ whenever setting the Row Number.

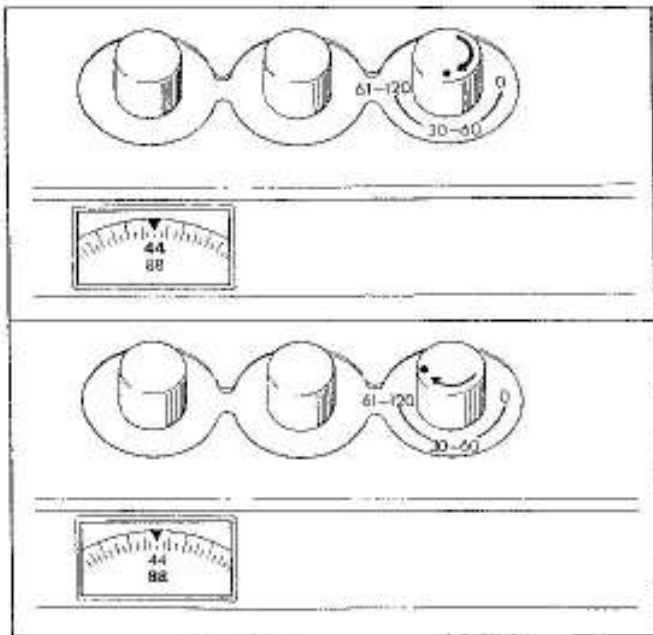

(3) Set the Change Dial either to 30-60 or 61-120.

* When the gauge row number is less than 60, set the Change Dial at 30-60, and the upper numerals function.

* When the gauge row number is more than 60, set the Change Dial to 61-120, and the lower numerals function.

When a thick yarn is used, set the Auxiliary Feeding Cam as shown on page 4.

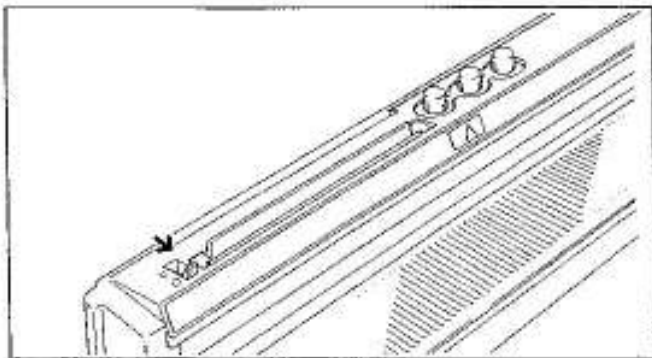

Set the Pattern Paper

(1) Set the Paper Lever to the ● mark.
(The Paper Holder is opened.)

When the Paper Lever is set at.....

- ▼the Pattern Paper is securely held.
-the Pattern Paper is free to move.

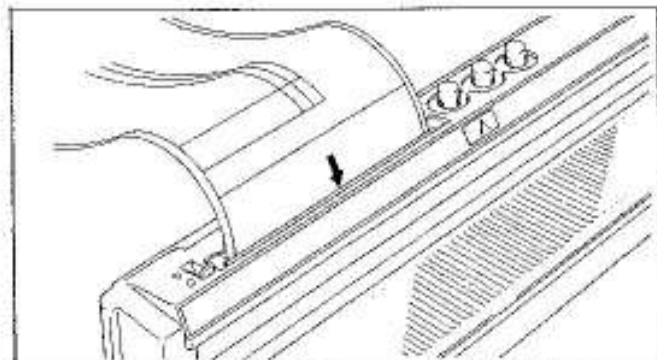

(2) Insert the selected Pattern Paper into the Paper Slit in the direction of its arrow mark.

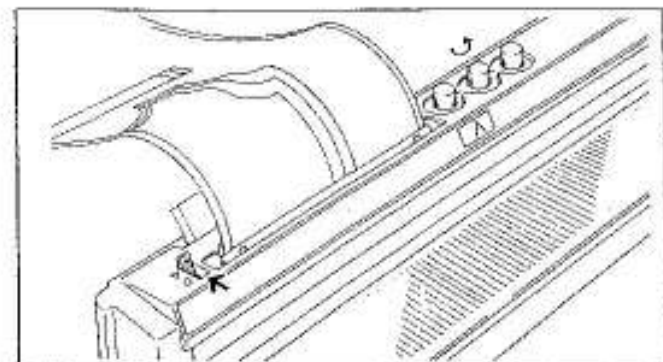

(3) After you have inserted the Pattern Paper 5-6cms., set the Paper Lever back to ▼ mark. Feed the Pattern Paper by turning the Feeding Dial until the bottom end of the Pattern Paper comes out from the rear slit.

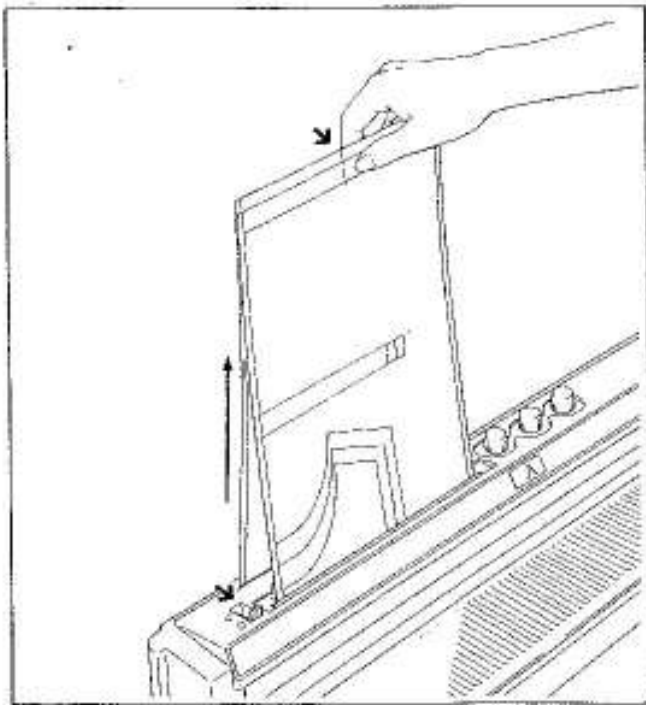

(4) Re-set the Paper Lever to the ● mark. Hold both ends of the Pattern Paper, joining the Centre Line of the front and back so that they are in a straight line.

(5) Afterwards, set the Paper Lever back to the ▼ mark.

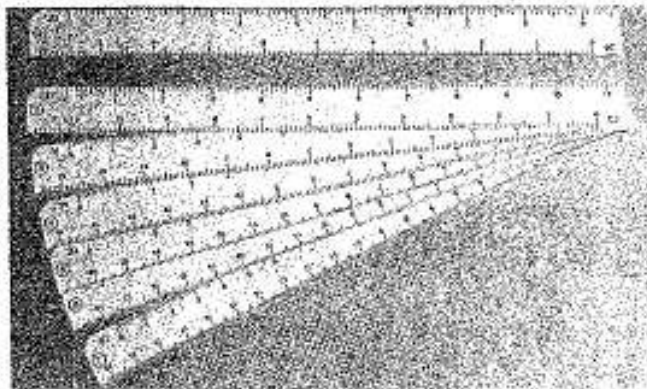

Select a Stitch Scale and set it

A set of 7 Stitch Scales and a set of 6 Centre Scales accompany the machine for the use on the Knit Contour.

The Scale is so designed to represent various size of a stitch measured by the Gauge Scale, and regulates the necessary number of stitches for shaping a garment when in use with the Pattern Paper.

The number at the corners of the Scale denote the number of stitches determined by using the Gauge Scale.

Example: The side 33 denotes that 33 stitches are there between actual 10cm. width.



Scale No.	①	②	③	④	⑤	⑥	⑦
Range of Stitches	23	27	31	35	39	43	47
	26	30	34	38	42	46	50

Scale No.	①	②	③	④	⑤	⑥
Range of Stitches	23	27	31	35	39	43
	26	30	34	38	42	44

Stitch Scale

7 scales are numbered ① through ⑦ and each of them covers four stitch sizes.

Centre Scale

6 scales are numbered ① through ⑥ and each of them covers four stitch sizes, but the scale ⑥ covers only two stitch sizes.

The Centre Scales are used for Slacks, Leggings, etc.

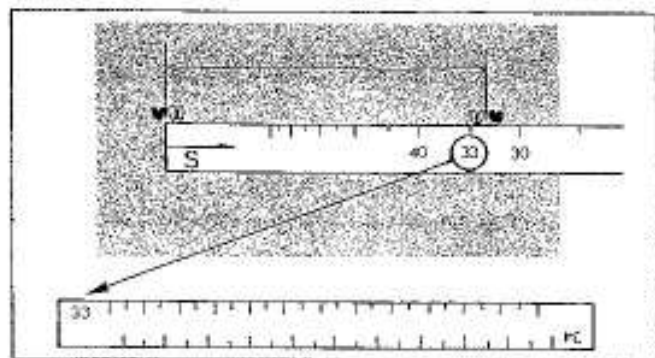

- (1) Select the Stitch Scale with the number equal to that of the stitches counted on the swatch.

(For example, if the number of stitches read on the Gauge Scale was 33, the Stitch Scale having 33 at the corner should be selected.)

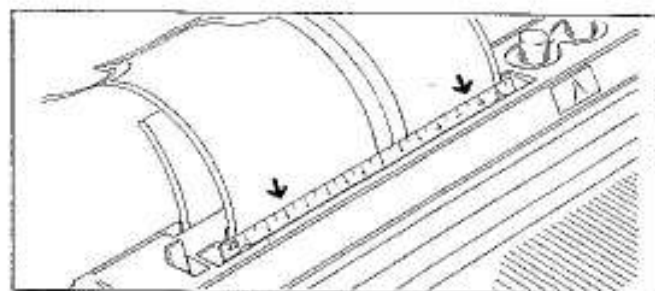

- (2) Insert the selected Stitch Scale into the Clips of the Paper Holder so as the selected number is facing you at the left side.

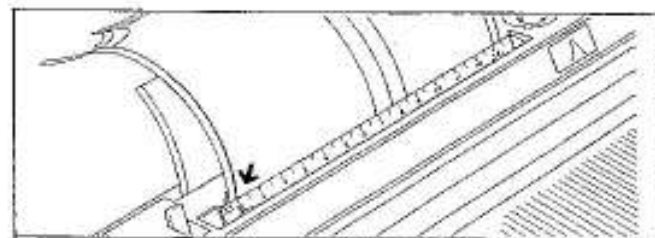

- (3) Adjust the Stitch Scale to fit its "0" mark with the Vertical Standard Line on the Pattern Paper.

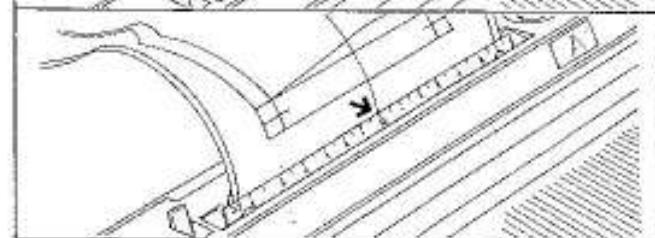

When using the Centre Scale, set its "0" mark at the Centre Line on the Pattern Paper.

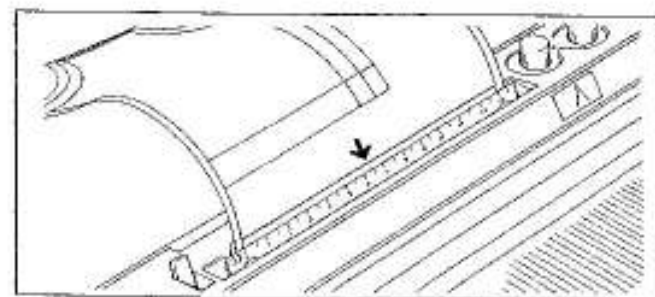

- (4) Return the Pattern Paper by turning the Feeding Dial to "R" direction till its Horizontal Standard Line appears at the Stitch Scale and adjust the setting of the Stitch Scale so as it is parallel to the Standard Line.

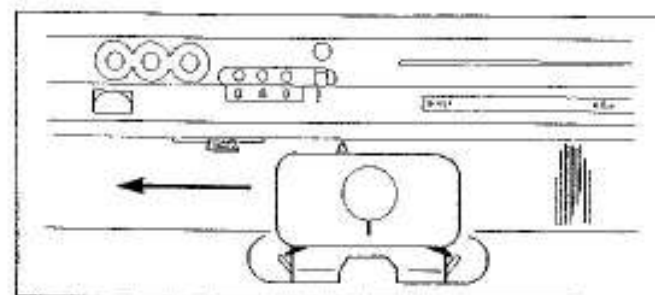

To operate the Knit Contour...

Move the Carriage till it hits the Feed Lever located at the Row Counter so as to feed the Pattern Paper.

TO UNDERSTAND PRINCIPLES OF THE KNIT CONTOUR

The **tension gauge** determined over the tension swatch is the base for making a garment to its correct size.

Example: Tension Gauge in 30 stitches by 40 rows.

The tension Gauge, designated as so many stitches and rows per 10cm., is represented by the Stitch Scale and row number. (30 stitches for Stitch Scale, and 40 rows for row number as an example.) They are considered to establish the same number of stitches and rows per 10cm. throughout the pattern in the Knit Contour (actually for each 5cm. square as the pattern is reduced to 1/2 size).

Those selected Stitch Scale and row number regulate the number of stitches and rows, and require the following basic technique at each step of knitting.

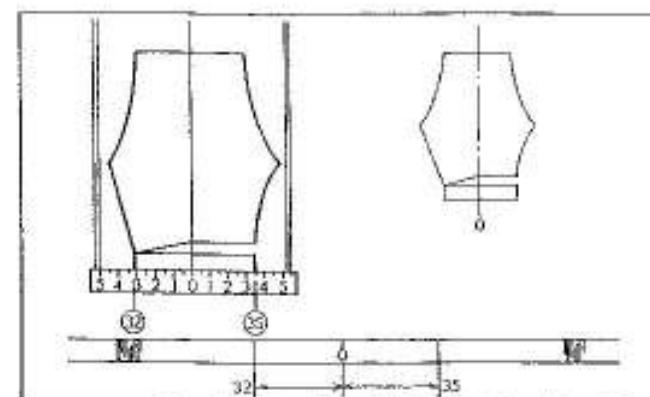
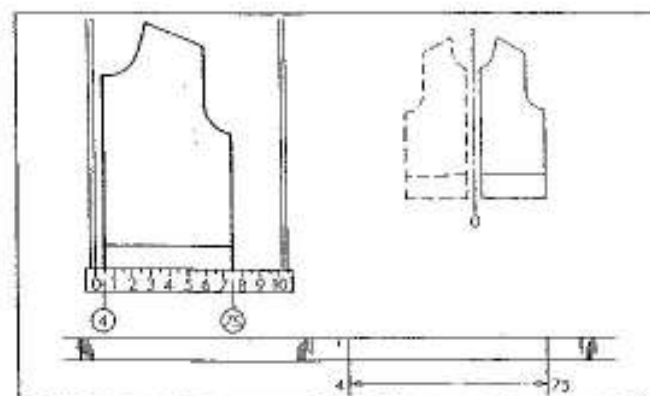
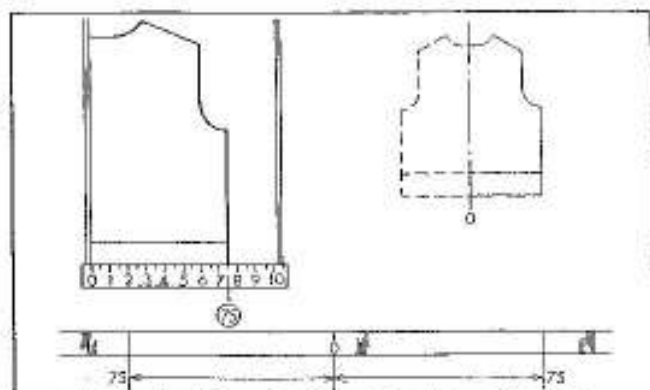
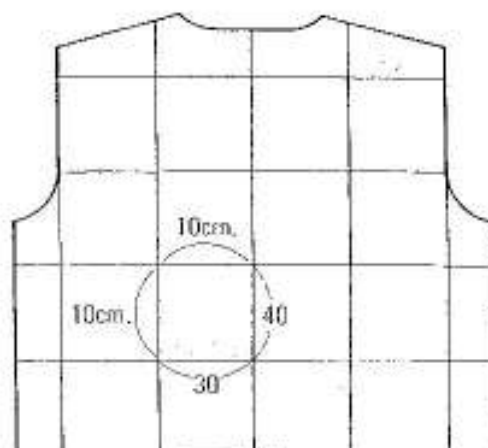

Cast on

- (A) Pattern styles given half of it centering the Vertical Standard Line.

(Example: Pullover, Skirt, etc.)

Cast on the same number of stitches as read on the Stitch Scale on both sides of "0" on the Needle Bed.

Shape the fabric symmetrically by applying the same technique on both sides.

- (B) Patterns given on the paper off the Vertical Standard Line.

(Example: Front of Cardigan, etc.)

Knit the right front and left front separately.

Cast on the same number of needles on either side of "0" on the Needle Bed and shape each side of the fabric differently.

To knit the other piece with the same pattern, read the number of stitches on the right side for the left and vice versa.

- (C) Whole pattern is given.

(Example: Slacks, Leggings, etc.)

Use a Centre Scale and set its "0" at the Centre Line on the Pattern Paper.

Read the number of stitches on the Scale for the right side and left side separately and cast on the same number of stitches.

Shape each side differently following the contour line, and to knit the other piece with the same pattern, read the number of stitches, on the right for the left and vice versa.

As the pattern paper advances in the Knit Contour, the crossing point of the contour line with the Stitch Scale shifts, and increase or decrease of number of imaginary sections set up by the selected Stitch Scale and the row number along the contour line require increase or decrease of stitches for shaping up a garment.

Basic techniques as required by the contour line are shown below as an example.

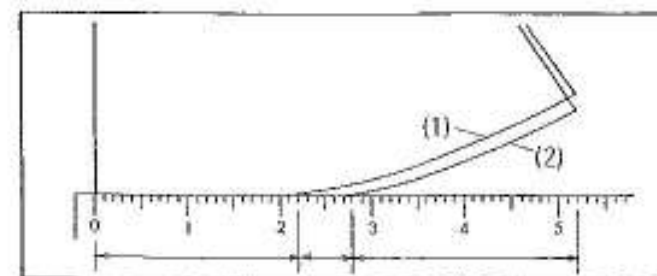
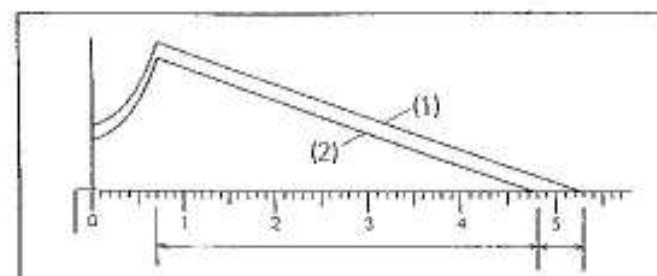
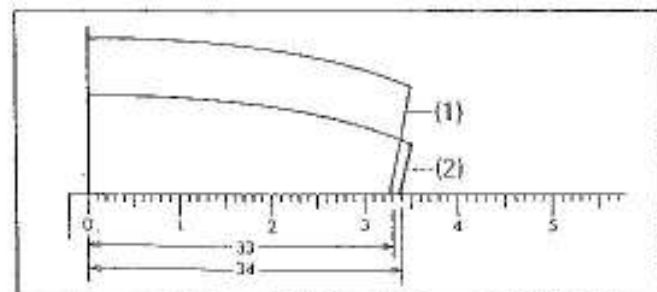
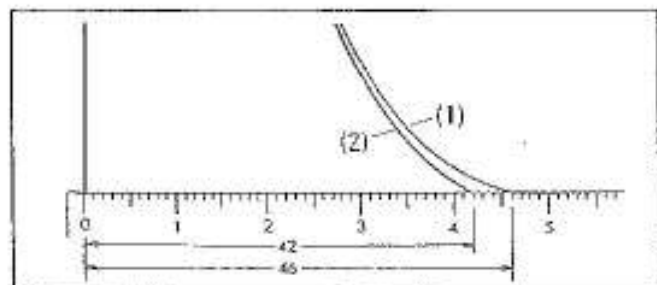
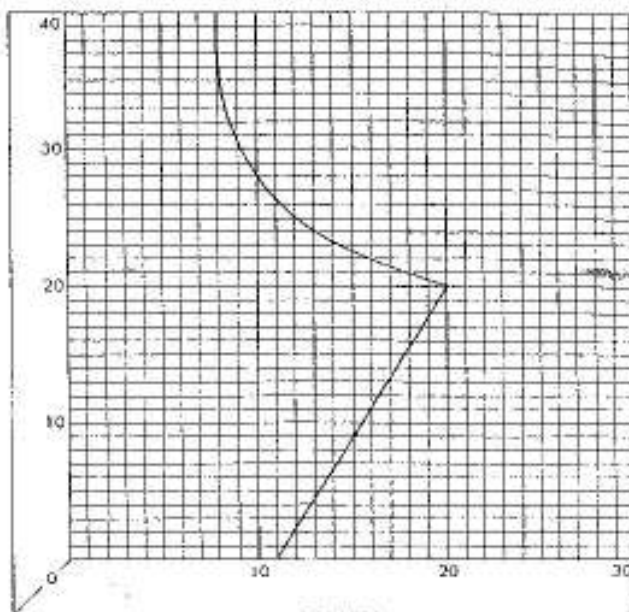

Decrease

- (1) 46 stitches are now on the machine.
- (2) As the Pattern Paper advances, the contour line shows 42 stitches at its crossing point with the Stitch Scale.
Decrease 4 stitches to have 42 stitches on the machine.

Increase

- (1) 33 stitches are now on the machine.
- (2) As the Pattern Paper advances, the contour line shows 34 stitches at its crossing point with the Stitch Scale.
Increase 1 stitch to have 34 stitches on the machine.

Partial Knitting by decreasing stitches

- (1) 53 stitches are now in B position on the machine.
- (2) As the Pattern Paper advances, the contour line shows 48 stitches at its crossing point with the Stitch Scale at the following row.
Push 5 needles to holding position on the side opposite the Carriage to have 48 stitches in B position.

Partial Knitting by increasing stitches

- (1) 22 stitches are now in B position on the machine.
- (2) As the Pattern Paper advances, the contour line shows 28 stitches at its crossing point with the Stitch Scale at the following row.
Push 4 needles back to knitting position to knit 28 stitches on the next row.

KNITTING ON THE KNIT CONTOUR



Following the instructions below, practise garment knitting with the use of the Pattern Paper.

The LADY'S PULLOVER (A-1) or MAN'S PULL-OVER (B-1) is taken as an example, and the techniques necessary for it are applicable to other types of garment.

The instructions given after the [P] mark should be followed when the Pattern Card is in use.

Before starting to knit, make sure the following preliminary steps:—

- (1) Select a pattern size and adjust its size if notably different from your size.
- (2) Take a tension gauge.
- (3) Set the Knit Contour correctly.

Note: If you made a mistake while knitting, correct it referring to page 21.

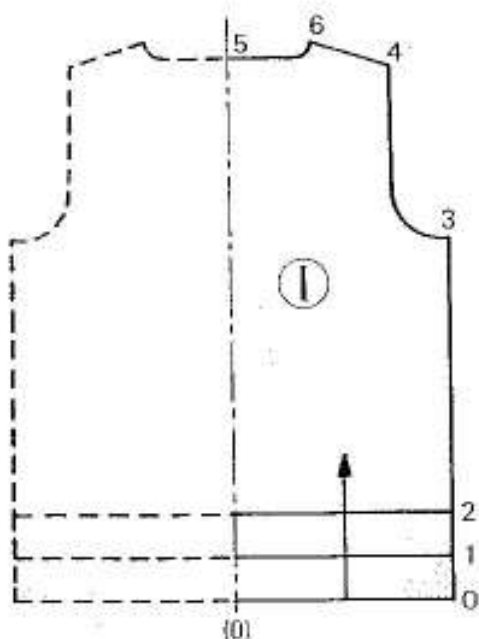

IF YOU ARE KNITTING ONLY ON THE KNITTER, WORK MOCK RIB FOR WELT, CUFF AND NECK-BAND IN PLACE OF K1.P1. RIB.

Back — pattern (I)

- (1) To work mock rib...
 - Set the Pattern Paper to starting line "0" for mock rib.
 - Read the number of stitches required for cast on.
 - Push up the same number of needles on both sides of centre(0) to B position and arrange them as shown.

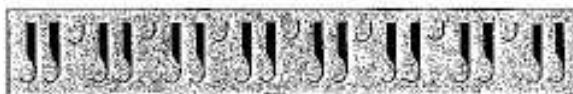

- With waste yarn, cast on and knit several rows.
- Knit 1 row with Ravel Cord.
- Set the Stitch Dial 3-4 numbers lower than the main tension and knit with main yarn up to "2".
- Push up the empty needles to B position.
- Turn up by placing the loops of the first row knitted in main yarn onto the corresponding needles. (Refer to page 33)

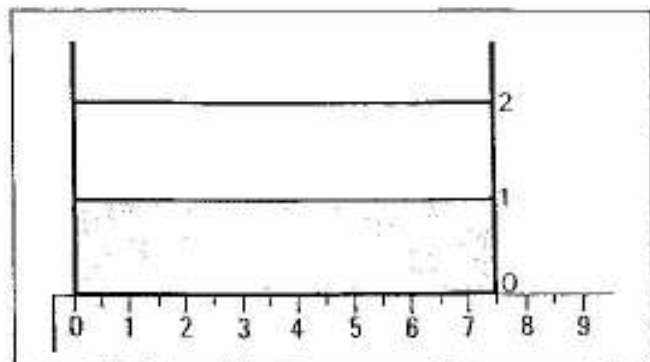

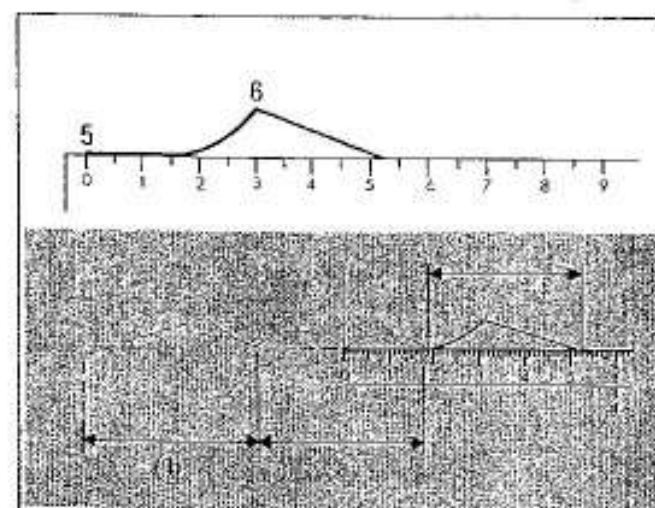
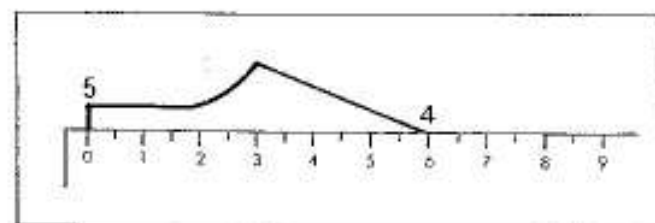
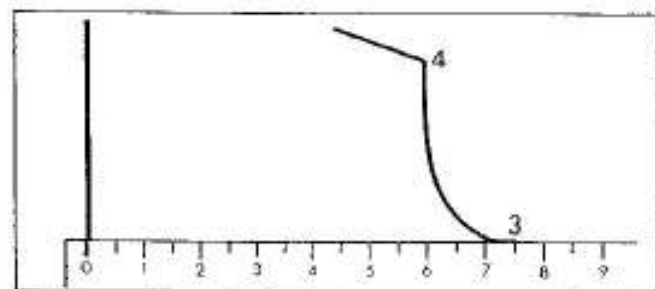
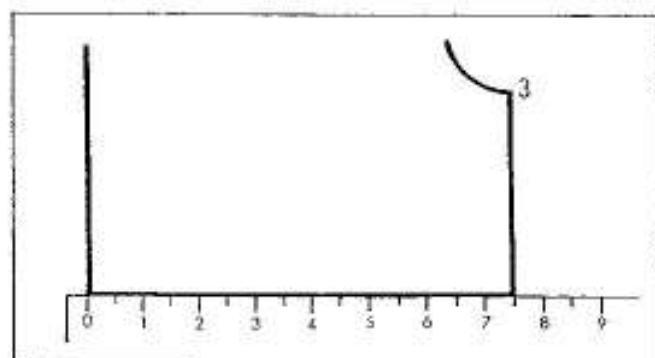
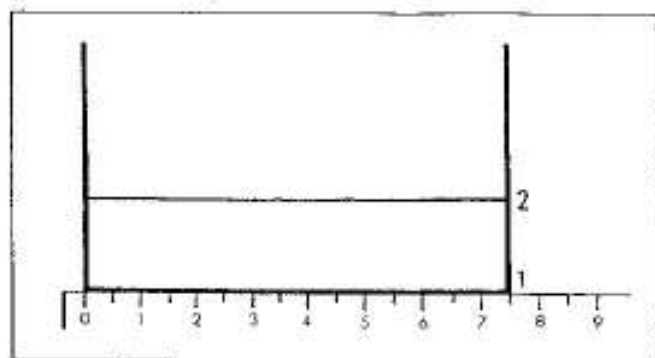

To work K1.P1. rib...

- Set the Pattern Paper to starting line "1". for K1.P1. rib.
- Read the number of stitches required for cast on and push up the same number of needles to B position on both the Knitter and Ribber.
- Arrange the needles for knitting K1.P1. rib by using the Needle Pusher and cast on.
- Knit up to "2" in K1.P1. rib.
- Transfer the Ribber stitches onto the Knitter and drop the Ribber to its lowest position.
- Exchange the Ribber Arm for the Knitter Arm, and remove the Ribber Weights and Cast on Comb from the fabric.

P Push "ON" the Inspection Button.
 Insert the Pattern Card and set it at the starting position.
 Push "OFF" the Inspection Button.

- (2) Set the Stitch Dial for the main tension and knit straight up to the armhole "3".

- (3) For the armhole, stitches must be decreased equally on both sides following the contour line. Continue to knit up to the shoulder point "4".

- (4) To shape the shoulder, apply decreasing (refer to page 26), and knit up to neckline "5".

- (5) At the neckline, divide into three sections, right, centre straight and left to work each section separately.

- (6) Read on the Stitch Scale the number of stitches for the centre straight section (a) and either the right or left section (b), opposite the Carriage, and hold their stitches (refer to page 30).

P Mark the present row number of the Pattern Card.

- (7) For the needles in B position, decrease the stitches at the neck and on the shoulder, up to the neck point "6".

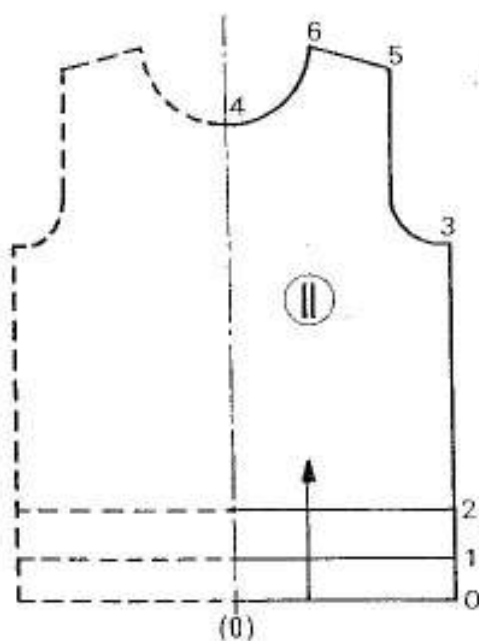
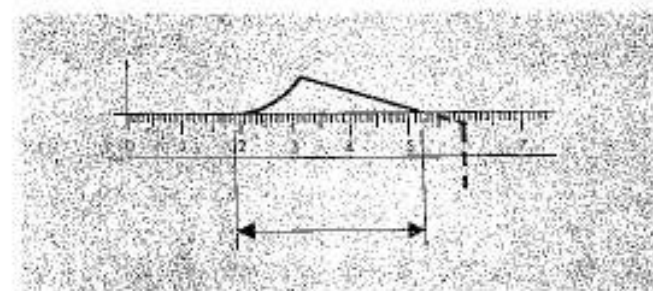
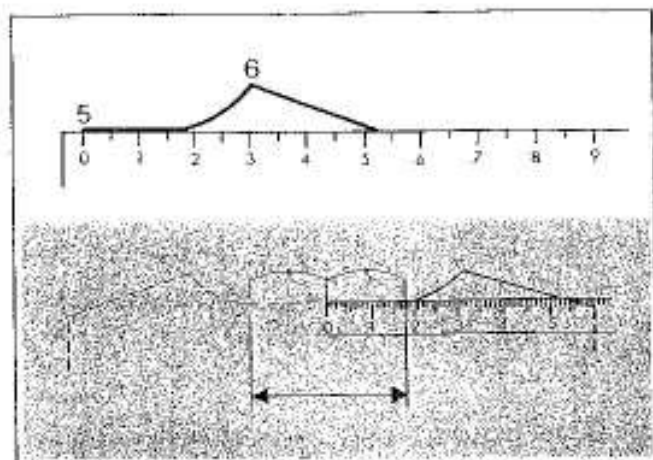
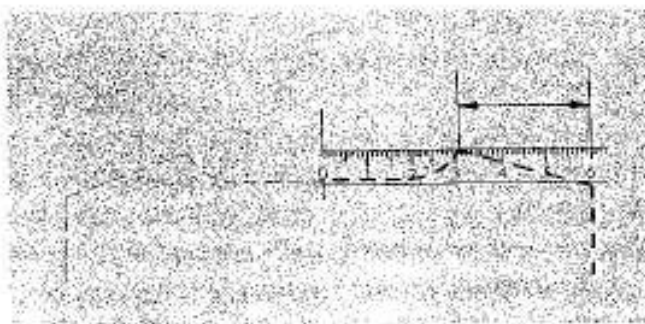

- (8) At the neck point, cut the main yarn, push the needles for the shoulder from holding position to knitting position and knit several rows of waste knitting over them (refer to page 31). Remove the section from the machine and push the empty needles back to A position.

P Return the Pattern Card to the same row number which you marked, and push "ON" the Inspection Button.

- (9) Return the Pattern Paper to the neckline "5" and read the number of stitches for the centre straight section. Push those needles to knitting position.

Set the Change Dial to ◀ and knit several rows of waste knitting over those needles.

Remove the section from the machine and push back the empty needles to A position.

- (10) For the second shoulder, apply the same techniques as done for the first shoulder but reverse shaping.

(a) Have the Carriage on the side of the first completed shoulder and re-set the Change Dial to the original setting.

(b) Replace the stitches which represent the remaining part of the shoulder, and align them in knitting position.

P Re-set the Cam Lever to the stitch type of the main knitting and push "OFF" the Inspection Button.

(c) Thread the main yarn into the Yarn Feeder and knit shaping the neck edge and the shoulder by decreasing stitches.

Front – pattern II

- (1) Set the Pattern Paper for the front and knit in the same manner up to the neckline "4" as done for the back.
- (2) At the neckline, divide into three sections, right, centre straight and left, to work each section separately.

P Mark the present row number of the Pattern Card and Push "ON" the Inspection Button.

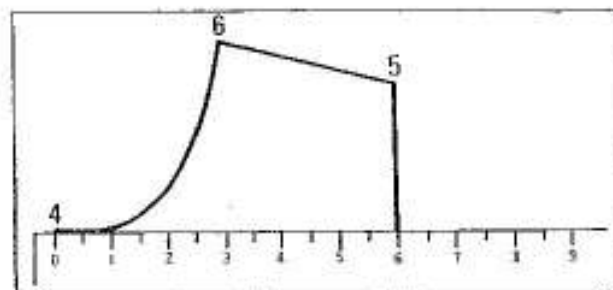

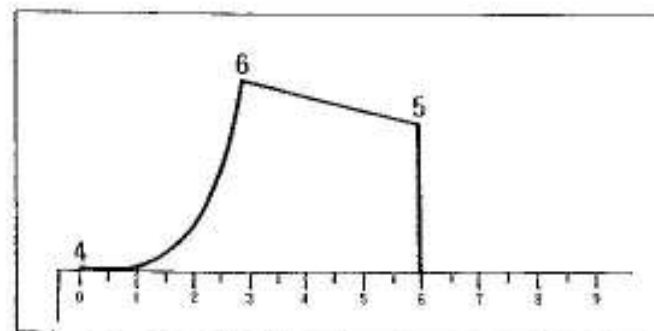
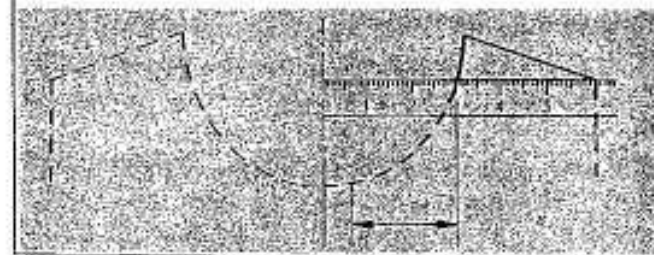
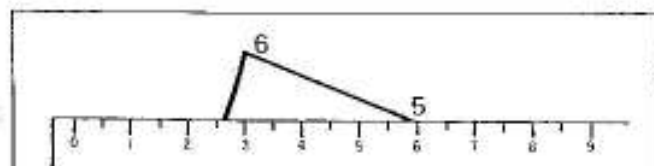
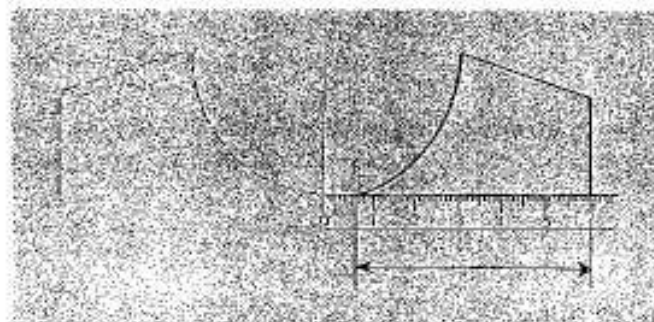
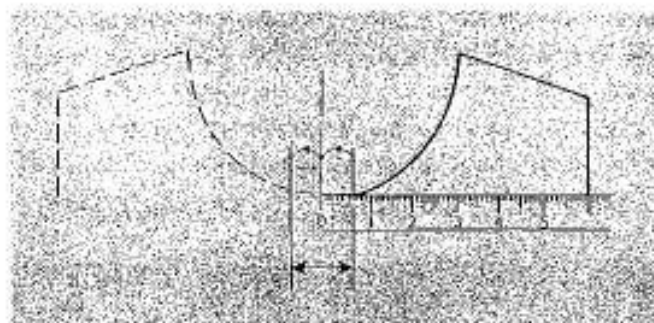
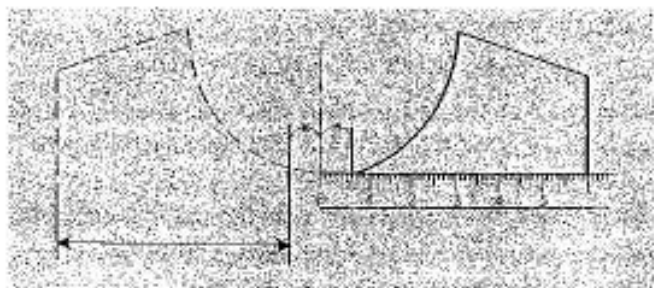

- (3) Read on the Stitch Scale, the number of needles for the centre straight and side section nearest the Carriage and push these needles to holding position.

Set the Change Dial to ◀ and knit several rows of waste knitting for the needles in B position.

Remove the section from the machine and push the empty needles back to A position.

- (4) Push the needles for the centre straight section of the neckline to knitting position and knit several rows of waste knitting.

Remove the section from the machine, (note the needle numbers) and push the empty needles back into A position.

- (5) Bring the Carriage to the side of the yarn, using the Transfer Tool, replace the stitches manually from holding to knitting position.

P Re-set the Cam Lever to the stitch type of the main knitting and push "OFF" the Inspection Button.

Re-set the Change Dial to the original setting and continue to knit shaping the neck edge by decreasing stitches up to the shoulder point "5".

- (6) From the shoulder point, shape the shoulders in partial knitting (decreasing stitches) and at the same time continue to decrease at the neck edge up to the neck point "6".

- (7) At the neck point, cut the main yarn, push the needles for the shoulder from holding position to knitting position.

P Return the Pattern Card to the card memory number you marked on the row at the neckline and push "ON" the Inspection Button.

Knit several rows of waste knitting, remove the section from the machine and push the empty needles back to A position.

- (8) Return the Pattern Paper to the neckline "4" and push the needles for the second half up into B position, and fill the needles with the stitches on the last row knitted in the main yarn.

P Re-set the Cam Lever to the stitch type of the main knitting and push "OFF" the Inspection Button.

Knit in the same manner as done for the first half, but reverse shaping.

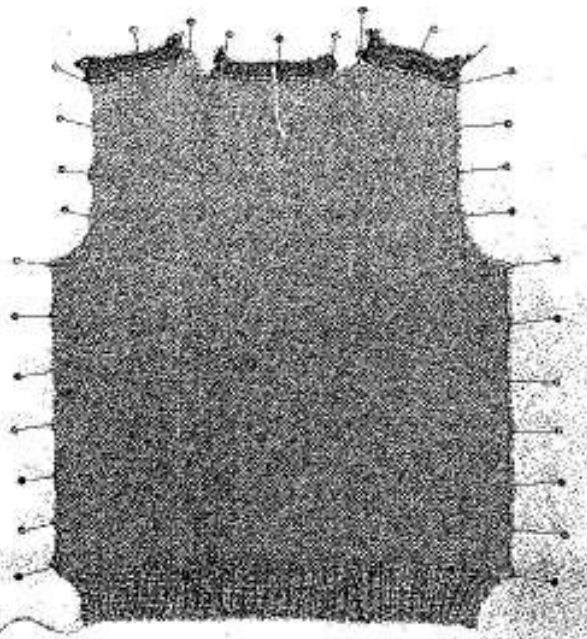
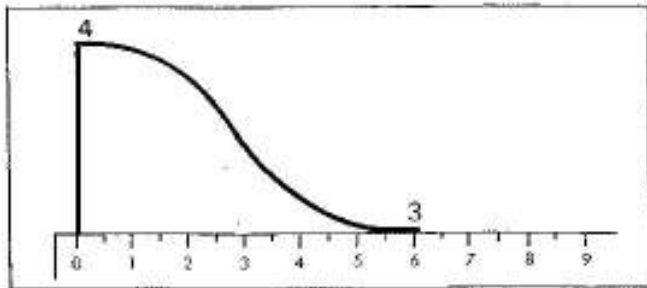
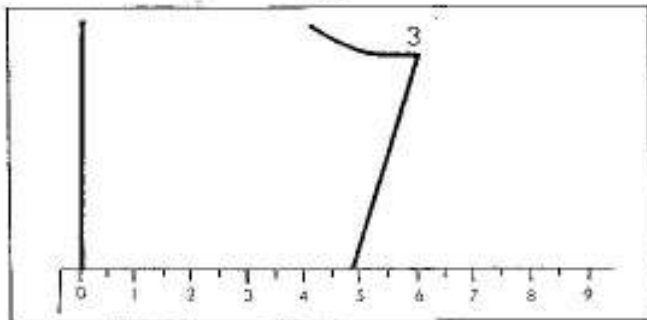
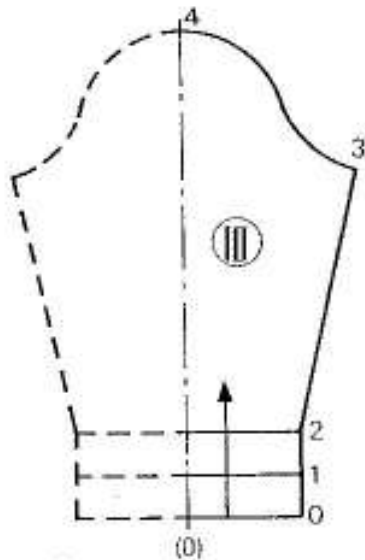

Sleeves — pattern (III)

Knit two pieces in the same pattern.

- (1) Set the Pattern Paper for the sleeve to the starting line "0" or "1" for knitting and read the number of stitches for the cast on.
In the same manner as done for the welt (refer to page 15 or 16), knit up to "2".

P Insert the Pattern Card and set it at the starting position.
Push "OFF" the Inspection Button.

- (2) Set the Stitch Dial and Row Number Dial for the main tension.

Knit up to "3", increasing stitches on both sides at the same time.

- (3) Shape the top by decreasing stitches.

- (4) Put a yarn mark at the centre of the top, and cast off the stitches (refer to page 32 or 33).

Blocking and pressing

After knitting the pieces of your garments, you must lay them flat and pin them out to their correct shape and size.

Then press them lightly with a warm iron over a damp cloth and leave the pieces to dry before removing the pins.

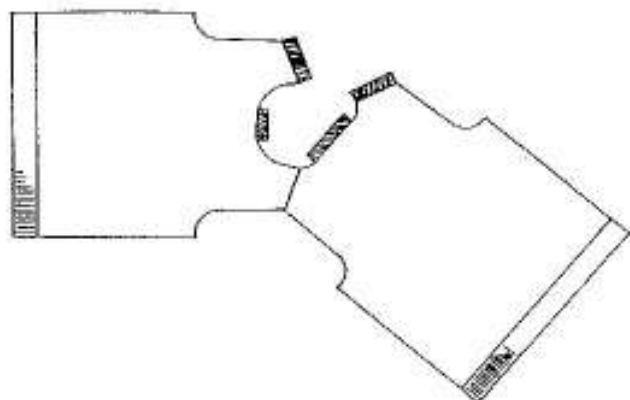

Join the right shoulder

With the right sides facing pick up the stitches of the last row knitted in the main yarn and place them onto the same needles.

Knit 1 row with the Main Carriage, setting the Stitch Dial at 8-9, and cast off by using the Automatic Linker or a Tappet Tool.

(Cast off using the Tappet Tool -- page 32)

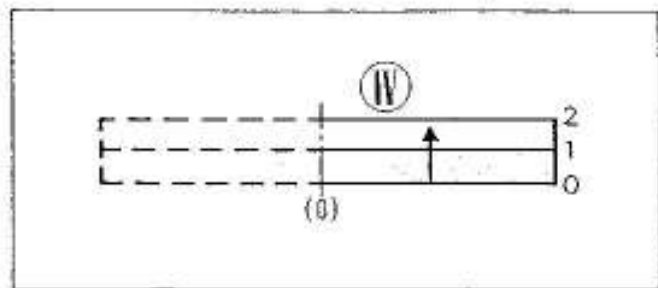

Neckband -- pattern (IV)

Set the Pattern Paper for the neckband to the starting line "0" or "1", then knit in the same manner as done for the welt (refer to page 15 or 16).

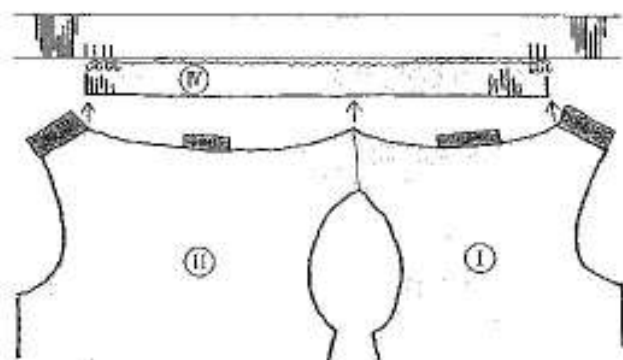

Join the neckband to the neck edge

Pick up the stitches from the neck edge evenly with the wrong side facing you and place them onto the same needles.

Knit 1 row with the Main Carriage, setting the Stitch Dial at 8-9, and cast off by using the Automatic Linker or a Tappet Tool.

(Cast off using the Tappet Tool -- page 32)

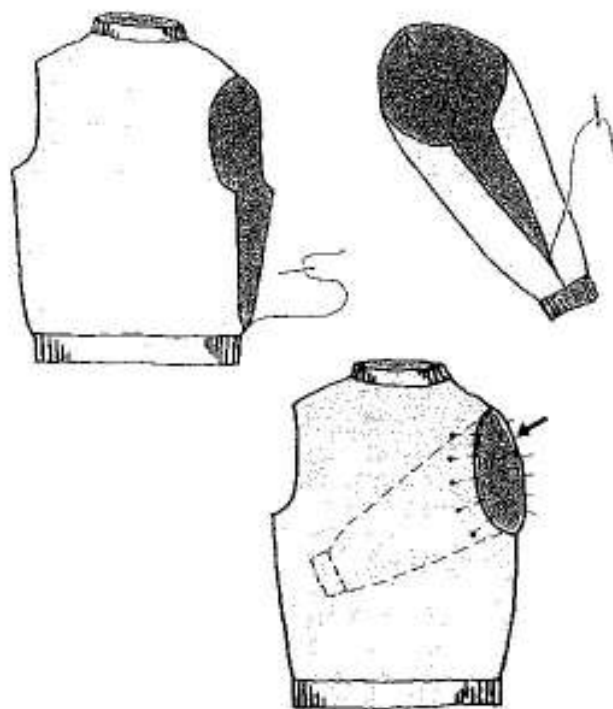

Making up

- (1) Pick up and finish off the left shoulder to correspond with the right shoulder.
- (2) Join the side, neckband and sleeve seams.
(Blind stitch -- page 37).
- (3) Turn the garment to the wrong side and slip the sleeves into the armhole. Pin them as illustrated and work slip stitch along the edges.
(Slip stitch -- page 37).

IF A MISTAKE TAKES PLACE WHILE KNITTING

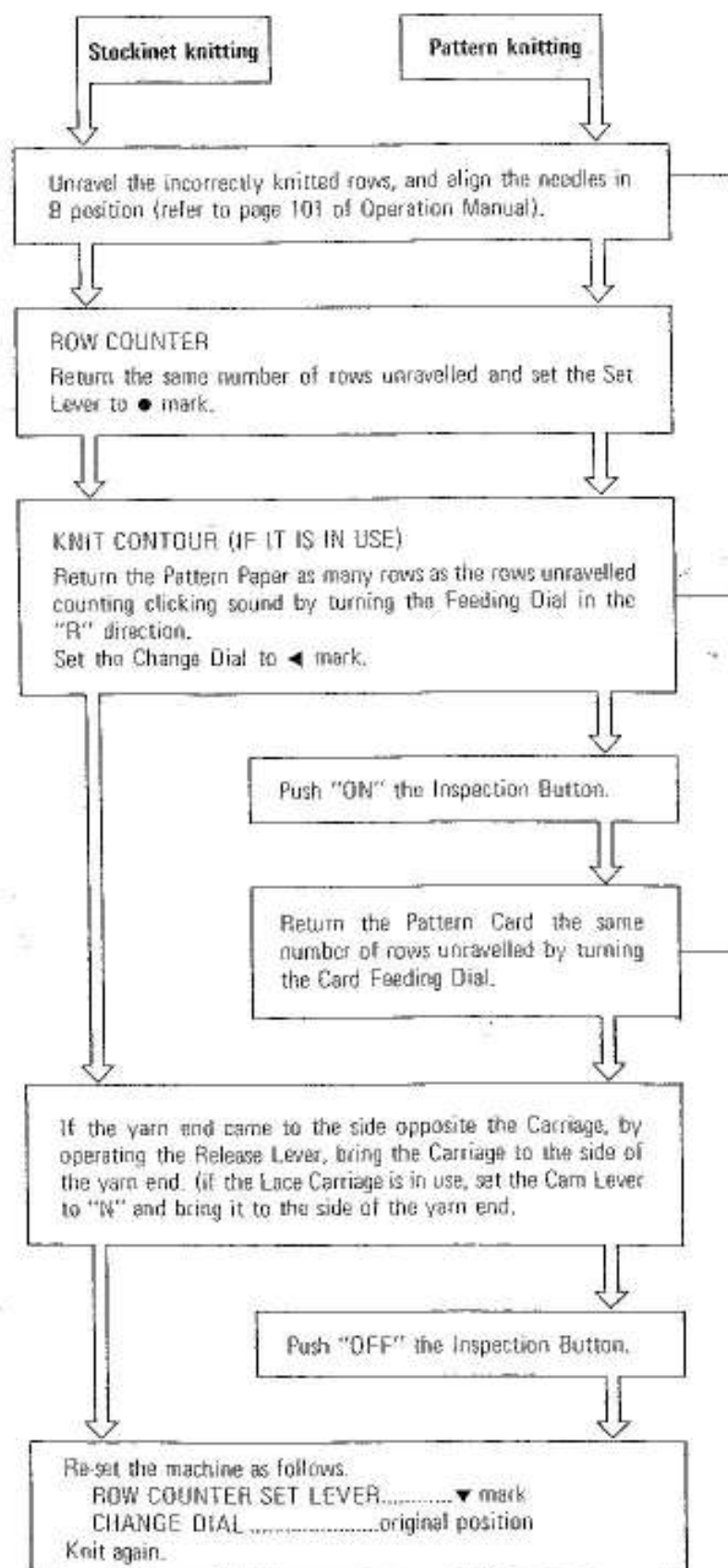

* If the vertical expansion is in use, unravel an even number of rows.

* In lace fabric, if there are empty needles on the same row to be unravelled, fill those needles with the stitches from the adjacent needles before unraveling (refer to page 101 of Operation Manual).

* If knitting is being done with the Change Dial at 61-120, return the Pattern Paper half the number of rows unravelled. (It is suggested to unravel even number of rows.)

* If the Auxiliary Feeding Cam is in use, return the Pattern Paper twice the number of rows unravelled.

* If the vertical expansion is in use, return the Pattern Card half the number of rows unravelled.

Example: If 3 rows have been knitted incorrectly, undo 4 rows and return the Pattern Card 2 rows, Row Counter and Knit Contour 4 rows.

* In case of lace knitting, the Card Memory Numbers in a box should not be counted in the number of rows to be returned.

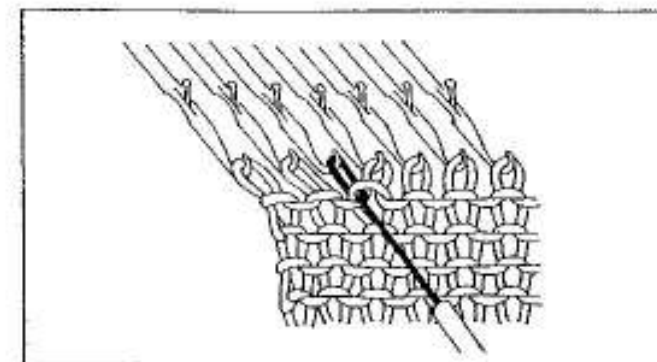
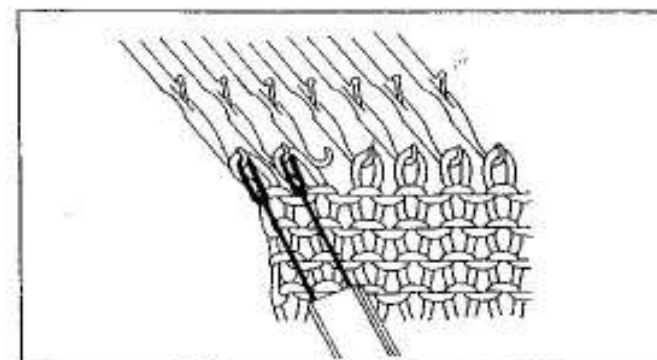
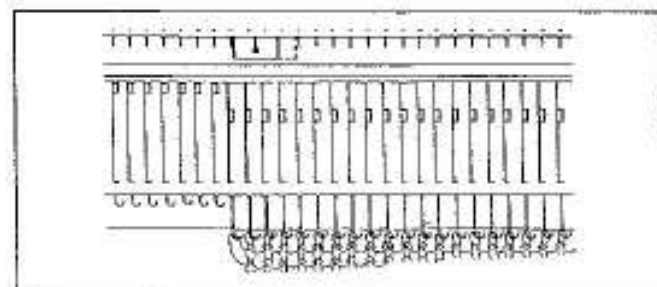
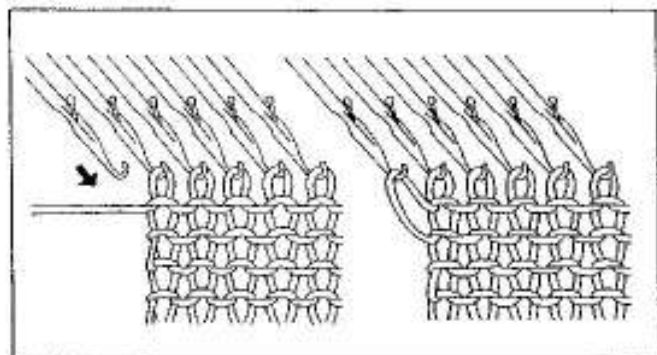

Increase

Increasing 1 stitch

You can increase 1 stitch at a time on the Carriage side.

1. Push 1 needle on the Carriage side from A to B position.
2. Knit 1 row.

When the Lace Carriage is in use, increase the stitch at the edge opposite to the side of the Carriage, and move the Point Cam to the new position by one needle before knitting the next row.

Fully fashioned increase

1. Adjacent to the end stitch push an empty needle up into B position. With the 2 x 1 tool, transfer the two end stitches one needle out.
2. Pick up the loop below the third stitch and place it onto the empty needle as shown. Continue to knit.

If the Lace Carriage is in use, move the Point Cam to the new position marking off two working needles when the carriage comes to the opposite side.



Increasing multiple stitches

You can only increase on the Carriage side.

This method can not be used when the Lace Carriage is in use.

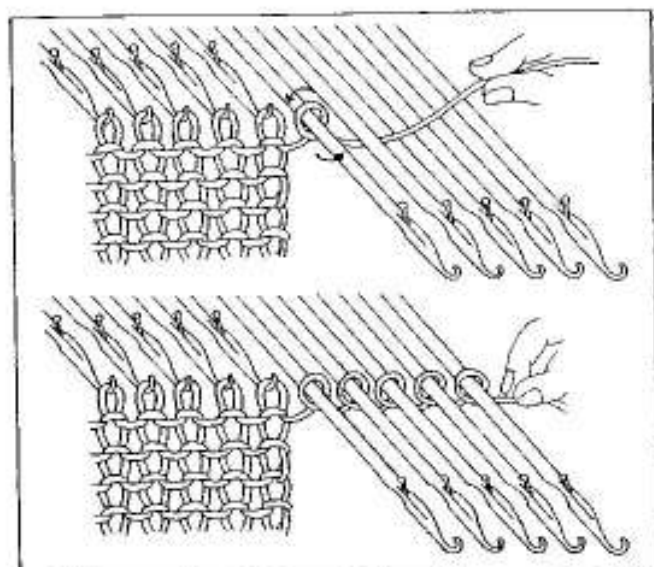

Carriage is on the right side.

1. Pull some yarn from the Yarn Feeder.
2. Push the required number of needles from A to D position.
3. Wind yarn loosely around the empty needles in the anti-clockwise direction.
4. Push loops against sinker posts.
5. Eliminate slack yarn.
6. Continue knitting.

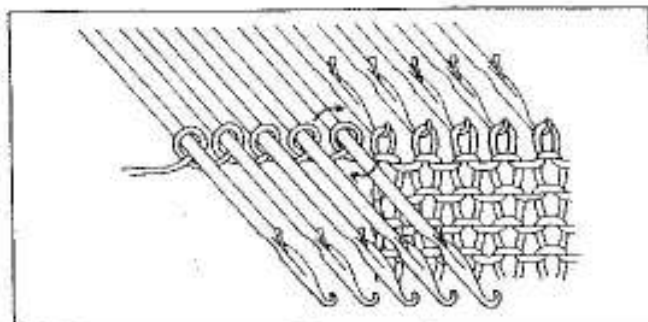

When the Carriage is on the left side, wind yarn around the needles in the clockwise direction.

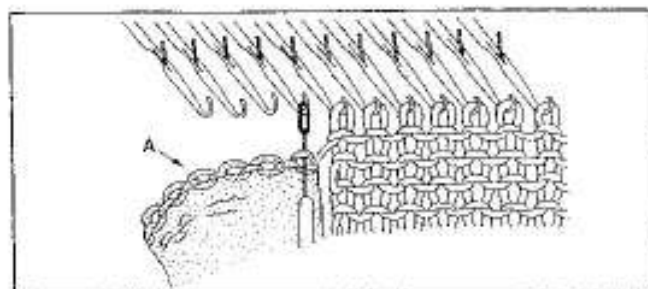

When the Lace Carriage is in use,

1. Push up the required number of needles for increase from A position to B on the side opposite to the Carriage.
2. Prepare a knitted piece "A", and using the Transfer Tool pick up stitches from it and hook them on the needles.
3. Hook the Claw Weight onto the knitted piece.
4. Push up the same needles from B position to D and lay the Ravel Cord "B" on needle latches.
(Stitches of the knitted piece are behind needle latches.)
5. Push the needles back one by one and form loops.

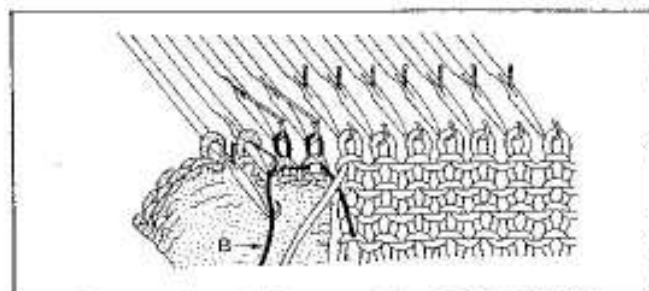

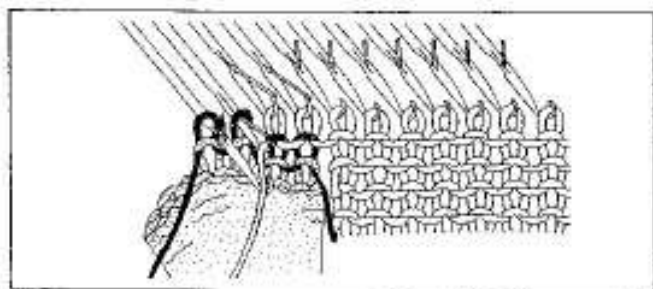

6. Push up the same needles again from B position to D and lay main yarn on the needle hooks.

7. Push the needles one by one again and form loops in the same manner as done for the Ravel Cord.

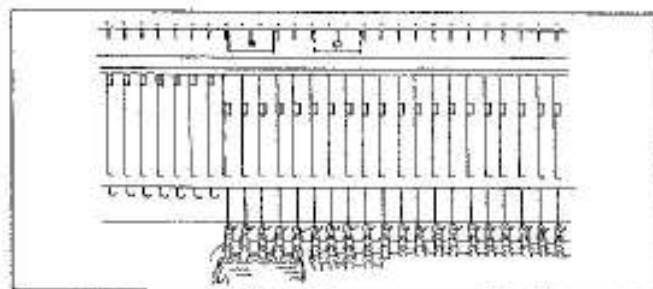

8. Move the Point Cam on the side of the increase to the new position to mark off two working needles at the new edge before knitting the next row.

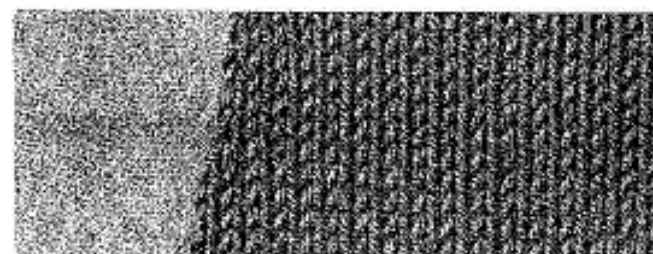

Decrease

Decreasing 1 stitch

You can decrease 1 stitch on both sides of the row.

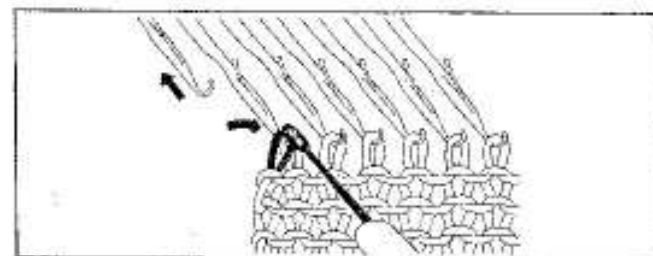

1. Using the Transfer Tool, transfer the end stitch onto its adjacent needle.

2. Push back the empty needle to A position.

3. Knit 1 row.

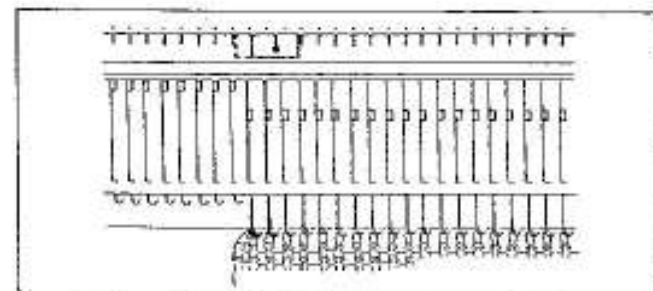

When the Lace Carriage is in use, decrease the stitch only on the side opposite to the Carriage, and move the Point Cam on the same side to the new position to mark off two working needles at the edge, before knitting the next row.

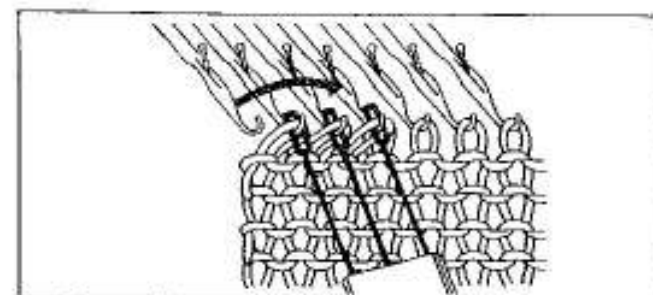

Fully fashioned decrease

1. With the 3 x 1 tool, transfer the three end stitches onto one needle in.

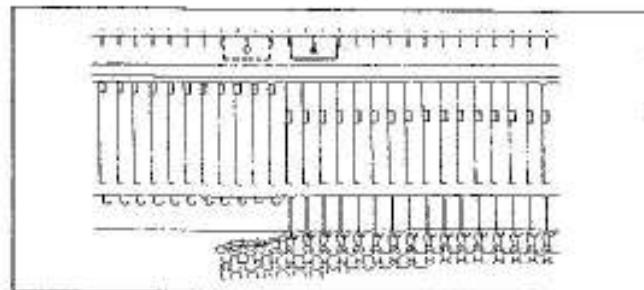
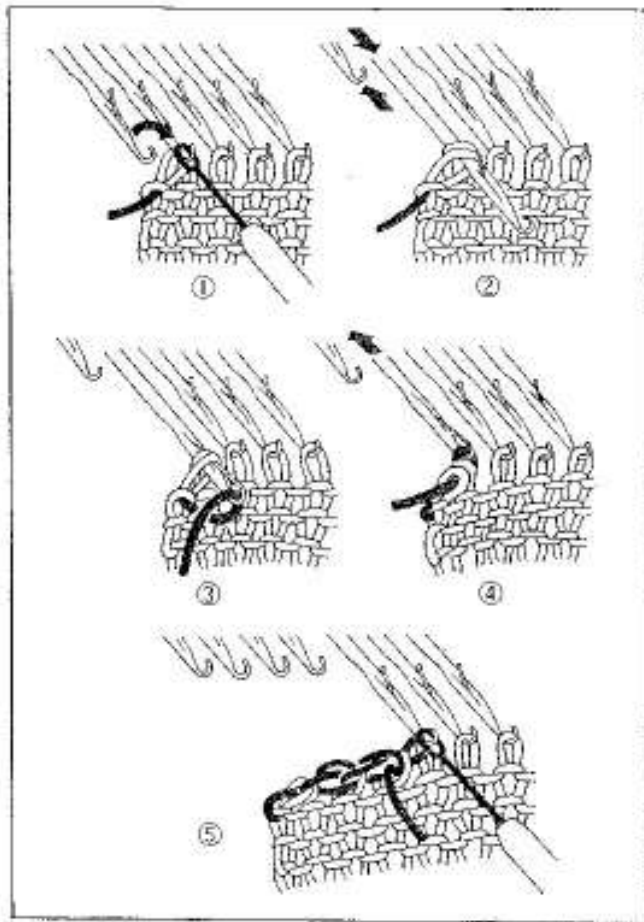
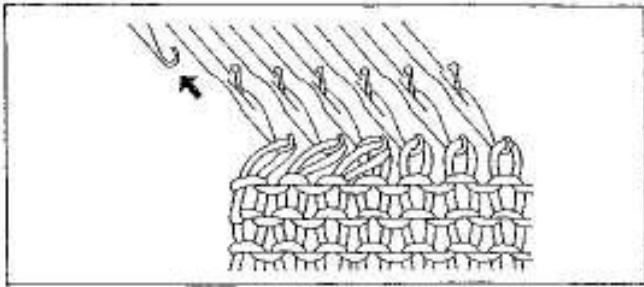

2. Push the end empty needle back to A position.
Continue to knit.

When the Lace Carriage is in use, perform the decrease on the side without the Carriage, and move the Point Cam of the same side to the new position to mark off two working needles at the edge, before knitting the next row.

Decreasing multiple stitches

You can only decrease on the Carriage side.

- ① On the Carriage side, hold the fabric against the Knitter.
Transfer the end stitch to the adjacent needle.
- ② Push the empty needle to A position.
Push the second needle to D position until both stitches are behind the latch.
- ③ Lay yarn from right to left on the open hook of the needle.
- ④ Hold yarn slightly down and push the needle back to B position.
The two stitches slip off the needle.
- ⑤ Continue this procedure until the required number of stitches have been decreased.
Place the last decreased stitch onto its adjacent needle.

Before knitting the next row, move the Point Cam to the new position to mark off two working needles at the new edge.

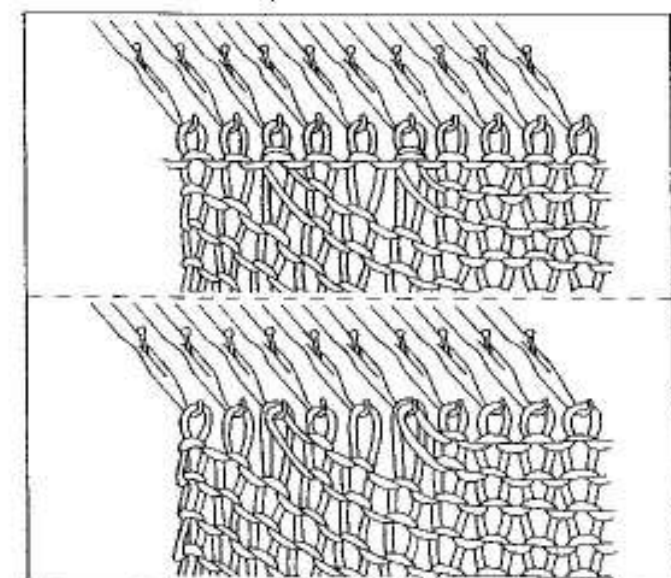
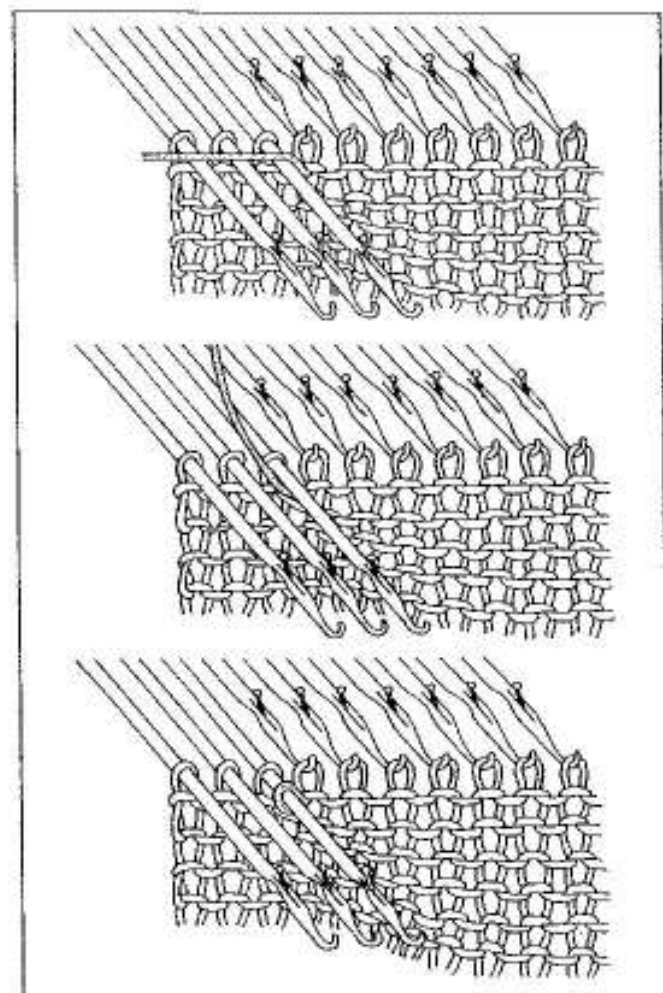
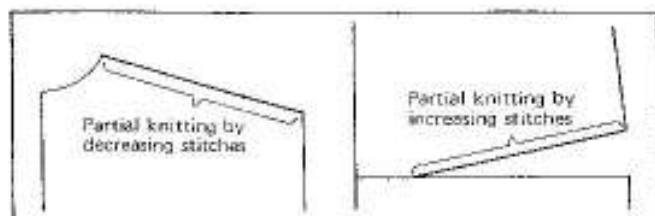

Partial knitting

PARTIAL KNITTING is a practical method for shaping a gentle slope, such as a shoulder, back of slacks and so on.

Partial knitting by decreasing stitches

(Main Carriage only)

Set the Russol Levers to the I position.

- (1) Push up the needles to be decreased, to D position, on the opposite side of the Carriage.

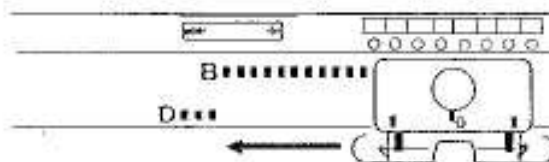

- (2) Knit 1 row. (The needles in B position knit the yarn. The needles in D position remain inactive and the yarn passes over them.)
- (3) To prevent a hole from being formed in the fabric, pass the yarn under the first inside needle in D position and over the other needles. (If partial knitting is required on both sides, apply step (1) before knitting the next row.)
- (4) Knit 1 row by moving the Carriage back. This completes the first operation of partial knitting.
- (5) Repeat steps (1)–(4).

At the completion of partial knitting, work as follows to knit continuously.

A. In case of stockinet knitting

Push the needles in D position back to C position. Needles in C position will knit and align in B position.

B. In case of pattern knitting

With a Transfer Tool, push the needles in D position towards A position until the stitches move onto the Transfer Tool, then place the stitches in the needle hooks.

Align the needles correctly in B position.

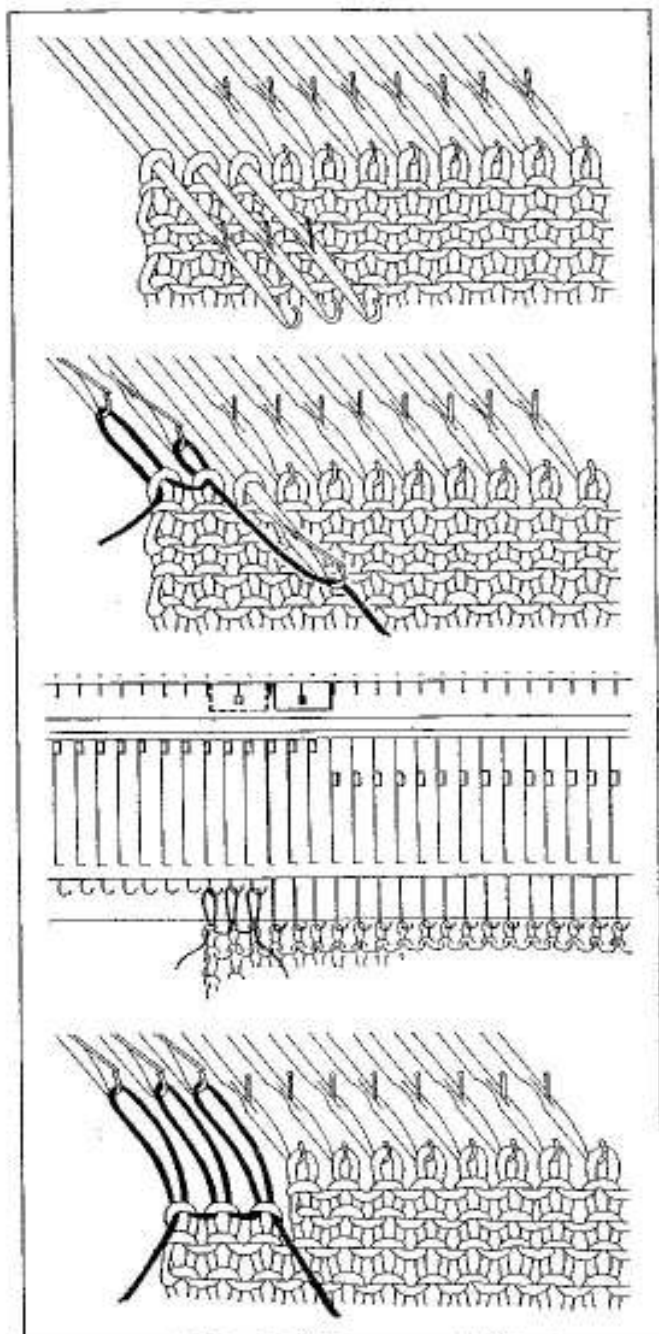

Partial knitting by decreasing stitches

(Lace Carriage only)

- (1) On the side without yarn end, push up the needles required for decrease to D position.
- (2) Lay the Ravel Cord into the open needle hooks, and knit the needles back one by one from D to A position by hand.
- (3) Move the Point Cam at the opposite side of the Carriage to the new position marking off two working needles from the separation of working and holding needles.
- (4) Knit two rows.
- (5) Repeat steps (1) through (4) as many times as is required.

When the partial knitting is completed, hang the weights and replace the stitches into needle hooks by pulling up the Ravel Cord.

- (6) Move the Point Cam at the opposite side of the Carriage to the new position marking off two working needles.

If partial knitting is required at both sides apply steps (1) to (3) and (4*). Knit 1 row.

Repeat steps (1) to (4*) as many times as required.

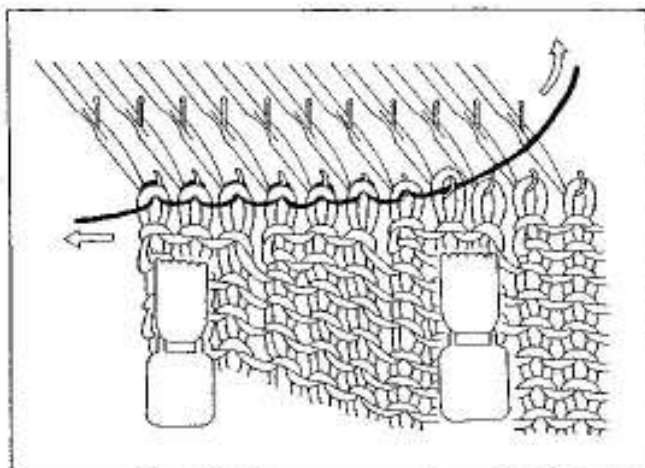

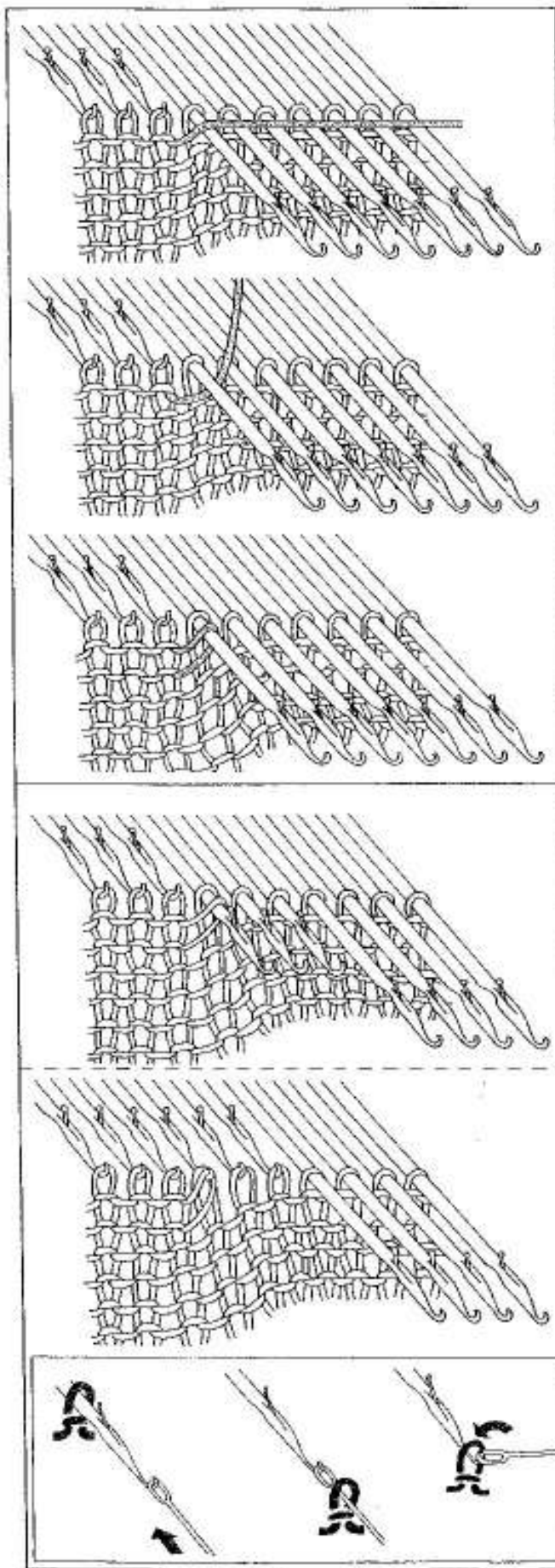

Partial knitting by increasing stitches

(Main Carriage only)

Set the Russel Levers to the I position.

- (1) On the side opposite the Carriage, push up the needles for the width to be shaped by partial knitting to D position.
- (2) Knit 1 row.
(The needles in B position knit the yarn. The needles in D position remain inactive and the yarn passes over them.)
- (3) Pass the yarn under the first inside needle in D position and over the other needles.
(If partial knitting is required on both sides, apply step (1) before knitting the next row.)
- (4) Knit 1 row by moving the Carriage back.
- (5) Before knitting the next row, work on the side opposite the Carriage as follows.

A. In case of stockinet knitting

Push the needles to be increased back to C position.

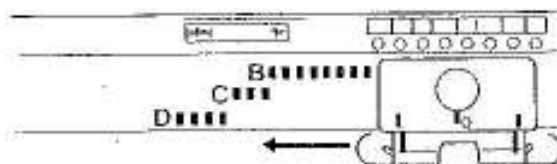

B. In case of pattern knitting

With a Transfer Tool, push the needles to be decreased towards A position till their stitches move onto the Transfer Tool. Then place the stitches in the needle hooks.

Align the needles correctly in B position.
(See the illustration.)

- (6) Repeat steps (2)–(5).

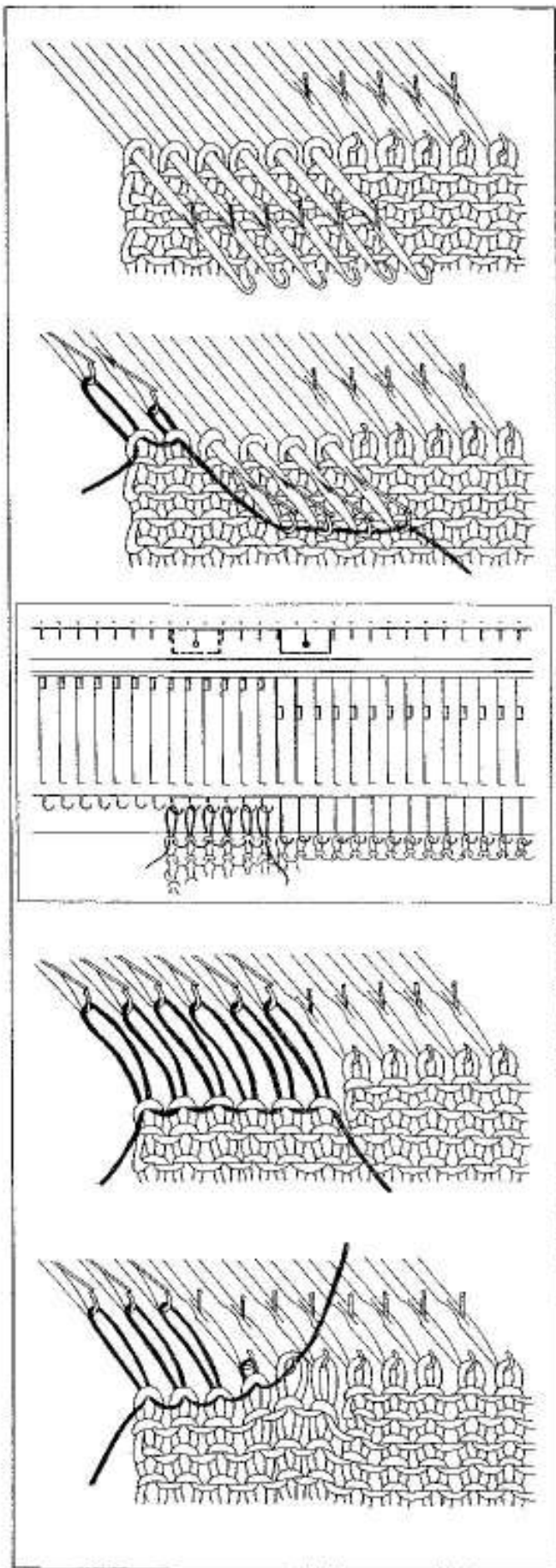

Partial knitting by increasing stitches

(Lace Carriage only)

- (1) On the side without yarn end, push up the needles required for shaping by partial knitting to D position.
- (2) Lay the Ravel Cord into the open needle hooks and knit the needles back one by one from D to A position by hand.
- (3) Move the Point Cam at the opposite side of the Carriage to the new position marking off two working needles from the separation of holding and working needles.

- (4) Knit two rows.

If partial knitting is required on both sides apply steps (1) to (3), but at step (4) knit 1 row only.

- (5) On the side without yarn end unravel the Ravel Cord to replace the stitches required for increase into the needle hooks.
 - (6) Move the Point Cam at the opposite side of the Carriage to the new position marking off two working needles.
- * Repeat steps (3) through (6) as many times as required for partial knitting.

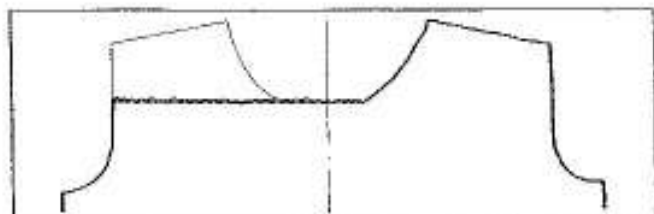

Holding stitches

When knitting separately as for the neckline, apply these methods to hold the stitches for latter work.

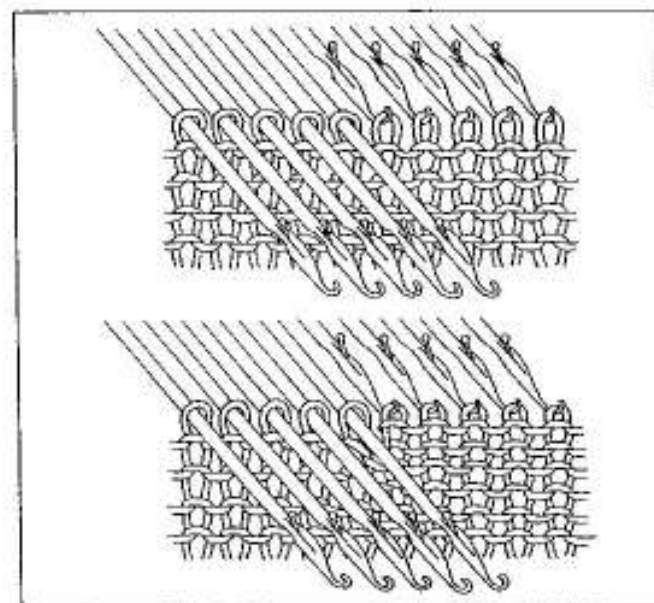

Holding stitches in D position

(Main Carriage only)

- (1) Push up the needles for the section to be held, to D position.
- (2) Set the Russel Levers to the I position and continue to knit for the needles in B position.

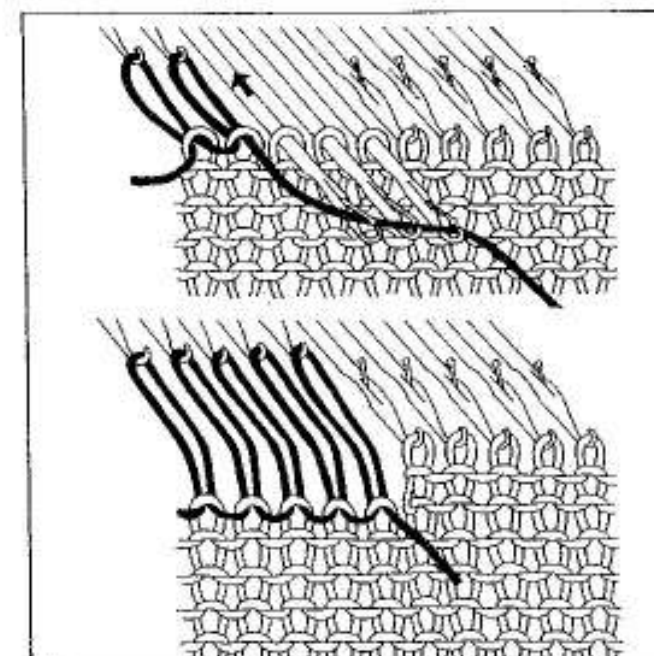

Holding stitches with Ravel Cord

- (1) Push up the needles for the section to be held, to D position, and lay the Ravel Cord across the hooks. Starting from the end needle, manually knit the needles one by one to A position.
- (2) Continue to knit over the needles in B position.

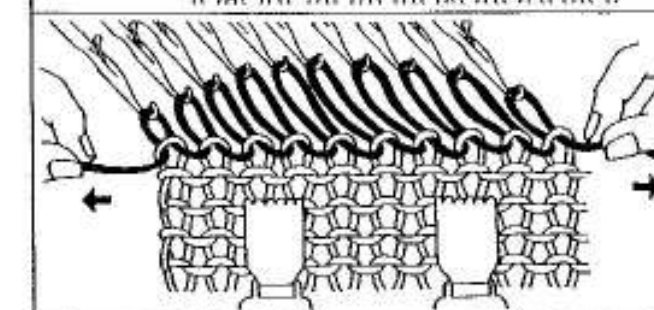

- * To replace the stitches, hold the Ravel Cord firmly at both ends and pull outwards bringing the needles to B position and replace the stitches in the needle hooks.

Note: Hang the Claw Weights.

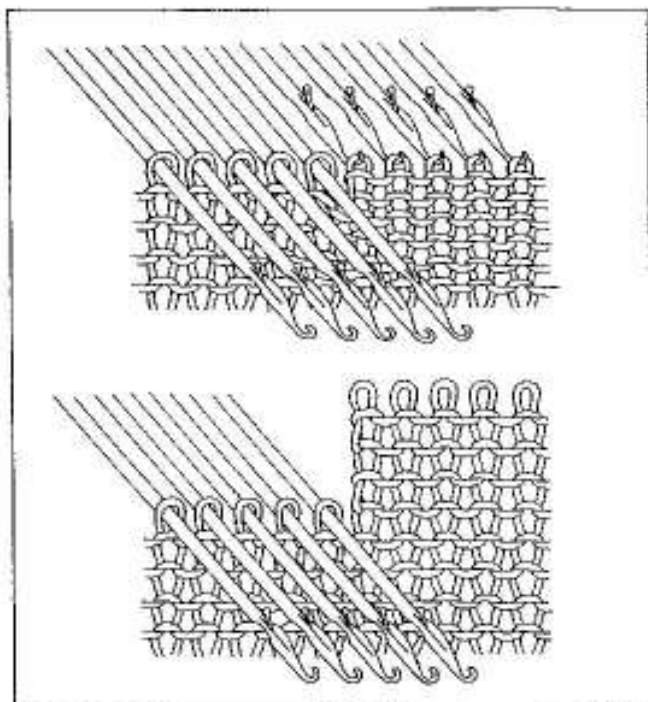

Holding stitches on waste knitting

(Main Carriage only)

Set the Cam Lever to STOCKINET (0) and the Russel Levers to the I position.

- (1) Leaving the needles in B position for the section to be held, push the remaining needles into D position.
- (2) Remove the section from the machine.

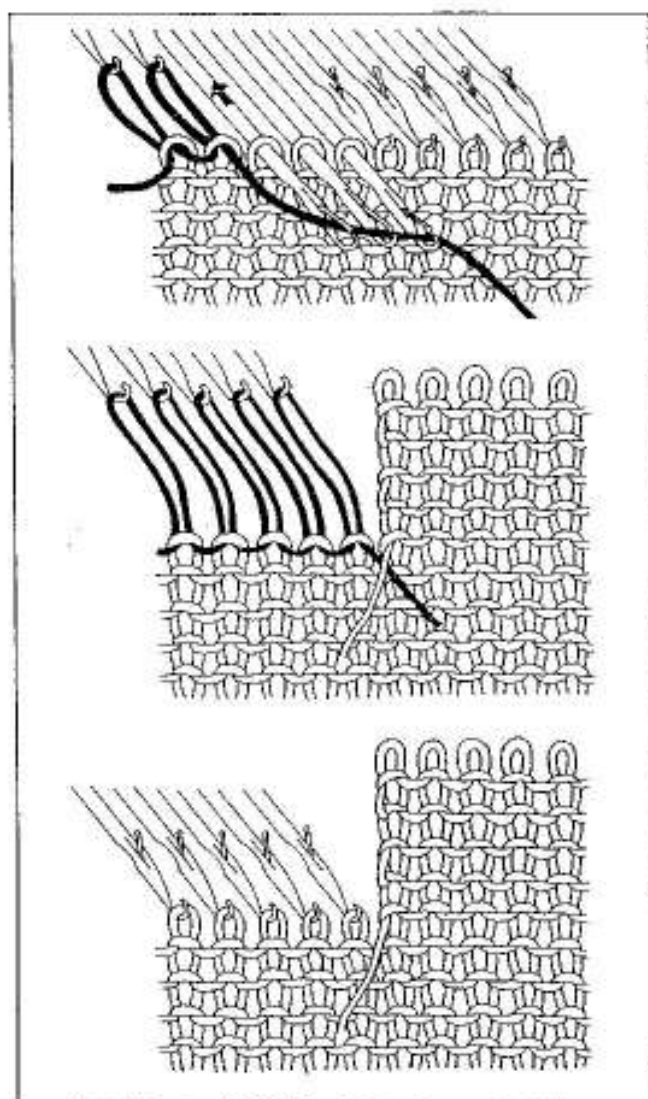

Holding stitches on waste knitting

(Lace Carriage only)

- (1) Except for the stitches to be held on waste knitting, push up the needles to D position.
- (2) Knit the Ravel Cord over the needles in D position by hand and back to A position one by one.
- (3) Push "ON" the Inspection Button, and knit the several rows of waste knitting over the needles in B position.
Then remove the section from the machine.

* To continue knitting, Push "OFF" the Inspection Button, unravel the Ravel Cord to replace the stitches in the needle hooks (refer to page 30).

When re-knitting the stitches held on waste knitting, pick up the stitches on the last row of the main knitting and place them onto the corresponding needles.

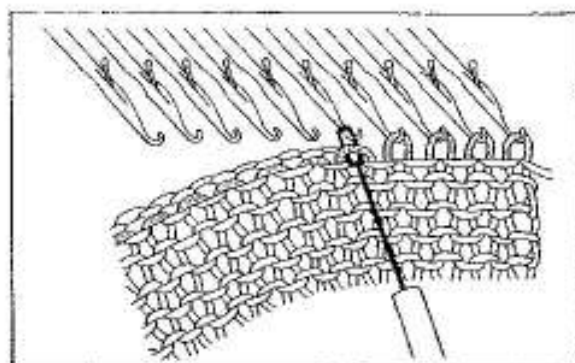

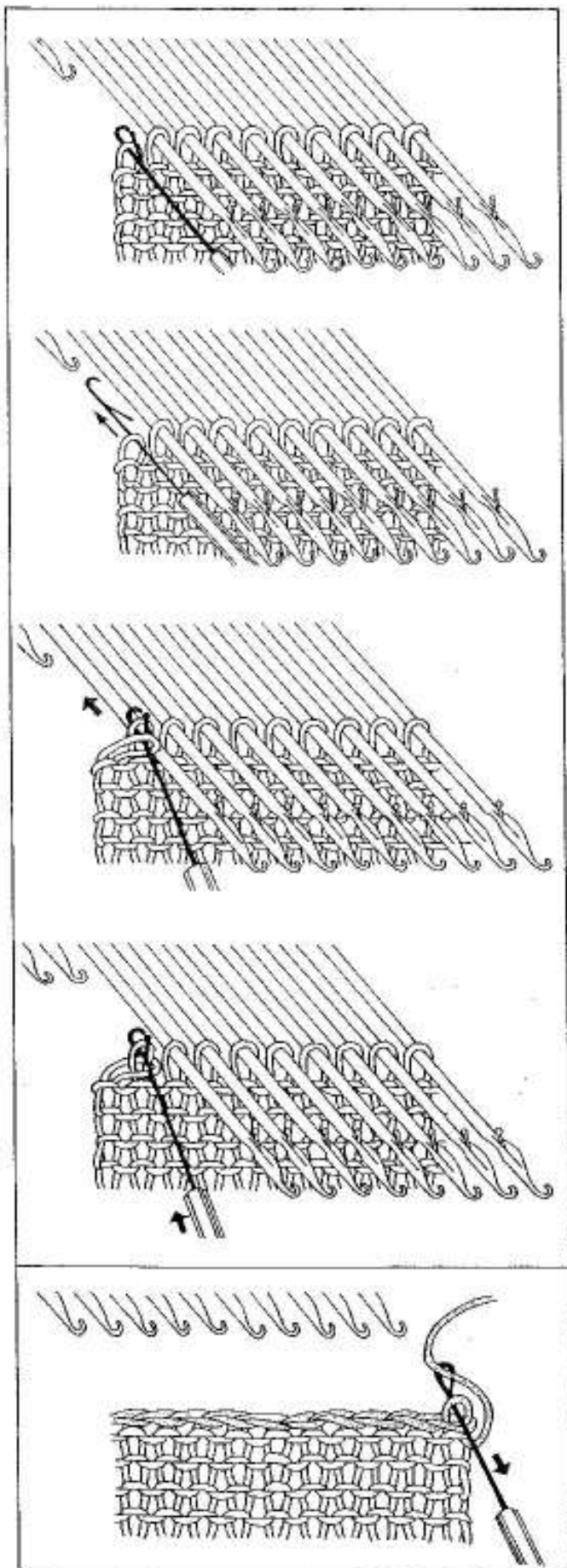

Cast off

Cast off with Tappet Tool

This is used for closing the stitches when main knitting is completed.

(1) Knit the cast off row with the Main Carriage, setting the Stitch Dial 3-4 numbers higher, then push the needles to D position. On the side opposite the Carriage, hook the first stitch with the Tappet Tool and push back the needle to A position. The stitch is transferred onto the Tappet Tool.

(2) Place the stitch behind the latch of the Tool.

(3) Hook the second stitch, push the needle back as indicated by the arrow but pull the Tappet Tool in the opposite direction.

The first stitch will have slipped off the tool.

(4) Repeat steps (2)-(3).

Cast off the last stitch by guiding the yarn end through the stitch with the Tappet Tool as shown.

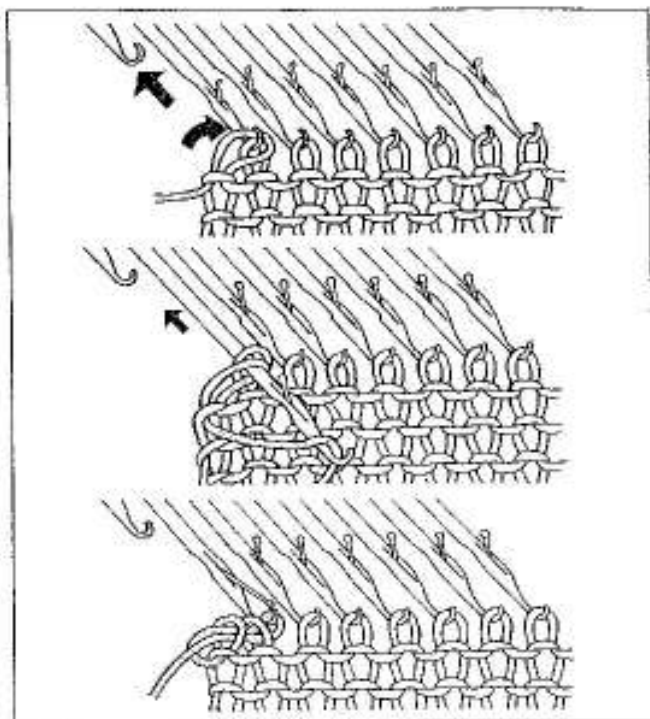

Cast off with Transfer Tool

- (1) Transfer the first stitch onto the second needle.
- (2) Push the second needle to D position to have both stitches behind the latch, and lay the yarn inside the needle hook.
- (3) Push the needle back towards A position.
- (4) Repeat (1)–(3)

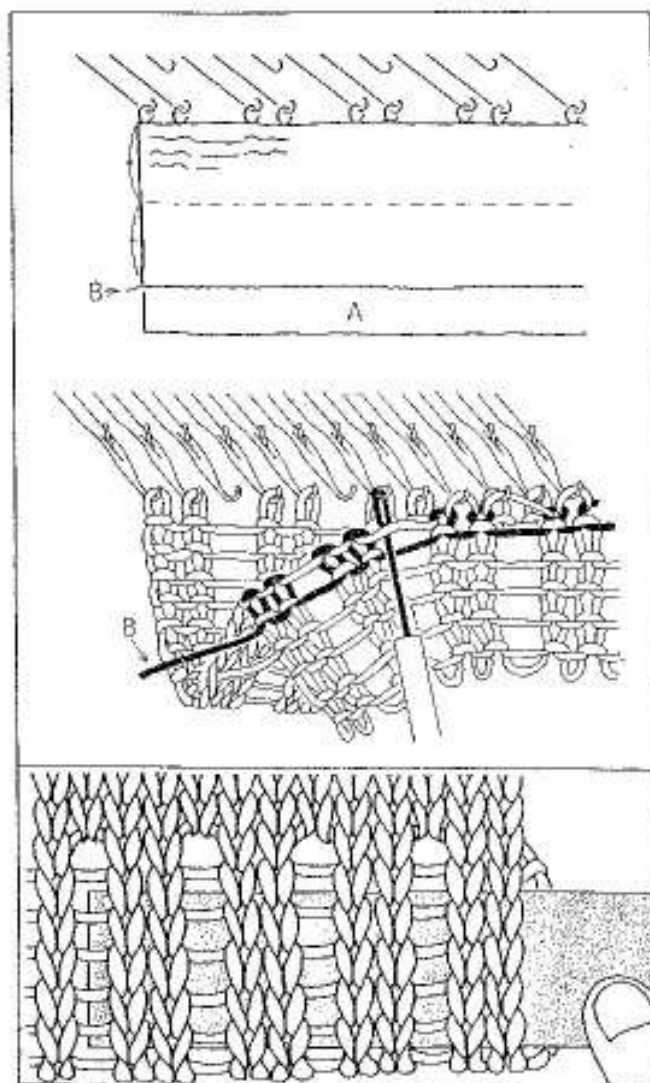

Mock rib

- (1) Push up the required number of needles to B position and push every third needle back to A position.
 - (2) Cast on and knit several rows of waste knitting "A", then knit one row with the Ravel Cord "B".
 - (3) Set the Stitch Dial 3 numbers lower than the original number and knit twice the depth of the hem.
 - (4) Return the needles that were pushed back to A position to B position. Pick up the sinker loops from the first row of the main knitting and place them onto the empty needles in B position.
 - (5) Reset the Stitch Dial to the original number and continue to knit.
- * If the Ravel Cord is pulled out, the waste knitting comes off.

When ironing, insert a ruler-like object into the side opening of the ribbed knitting and stretch the fabric vertically.

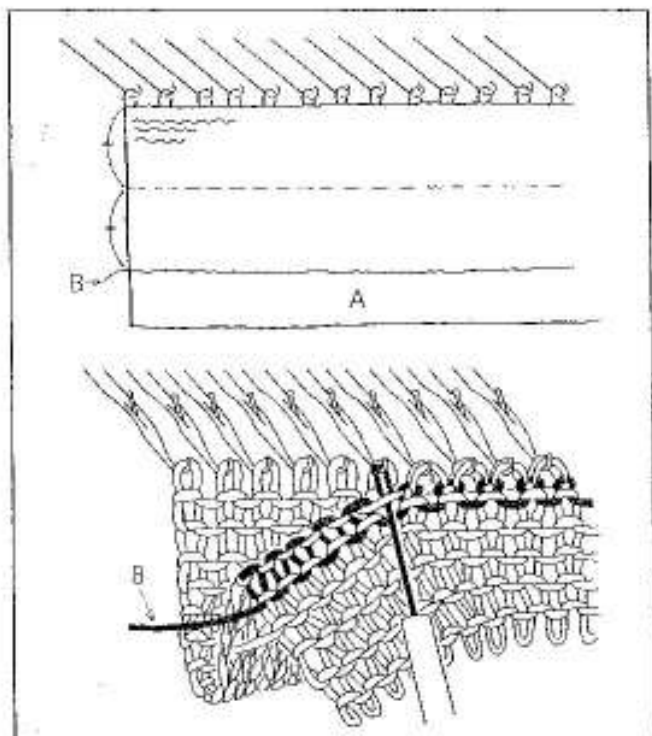

Hemming

- (1) Cast on and knit several rows of waste knitting "A" then knit one row with the Ravel Cord "B".
 - (2) With the main yarn, knit twice the depth of the hem.
 - (3) Pick up the sinker loops from the first row of the main knitting and place them onto the corresponding needles.
 - (4) With the Stitch Dial set 2 numbers higher, knit one row.
 - (5) Set the Stitch Dial to the original number and continue to knit.
- * If the Ravel Cord is pulled out, the waste knitting comes off.

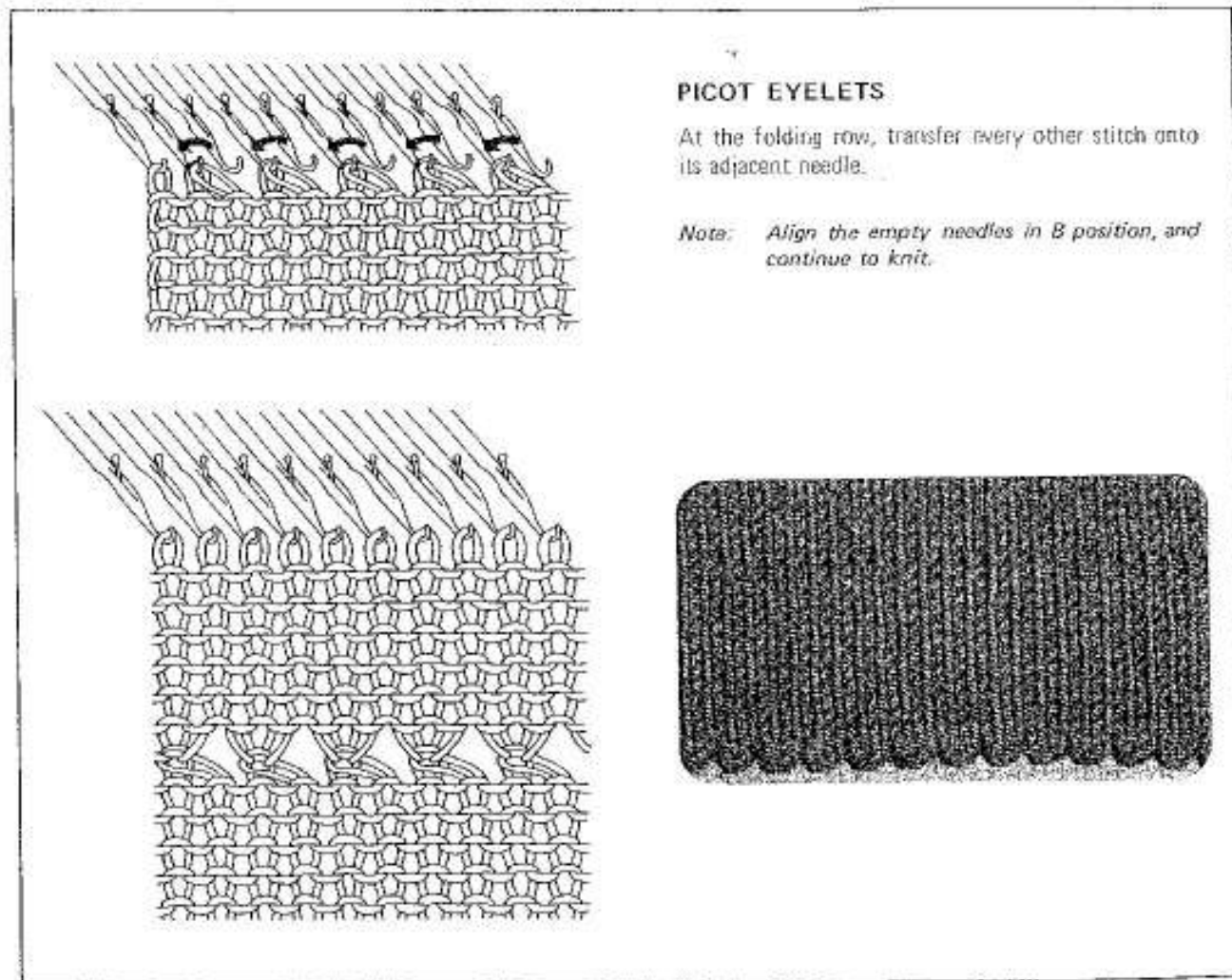

PICOT EYELETS

At the folding row, transfer every other stitch onto its adjacent needle.

Note: Align the empty needles in B position, and continue to knit.

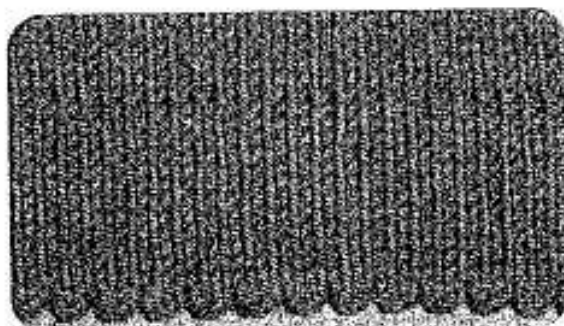

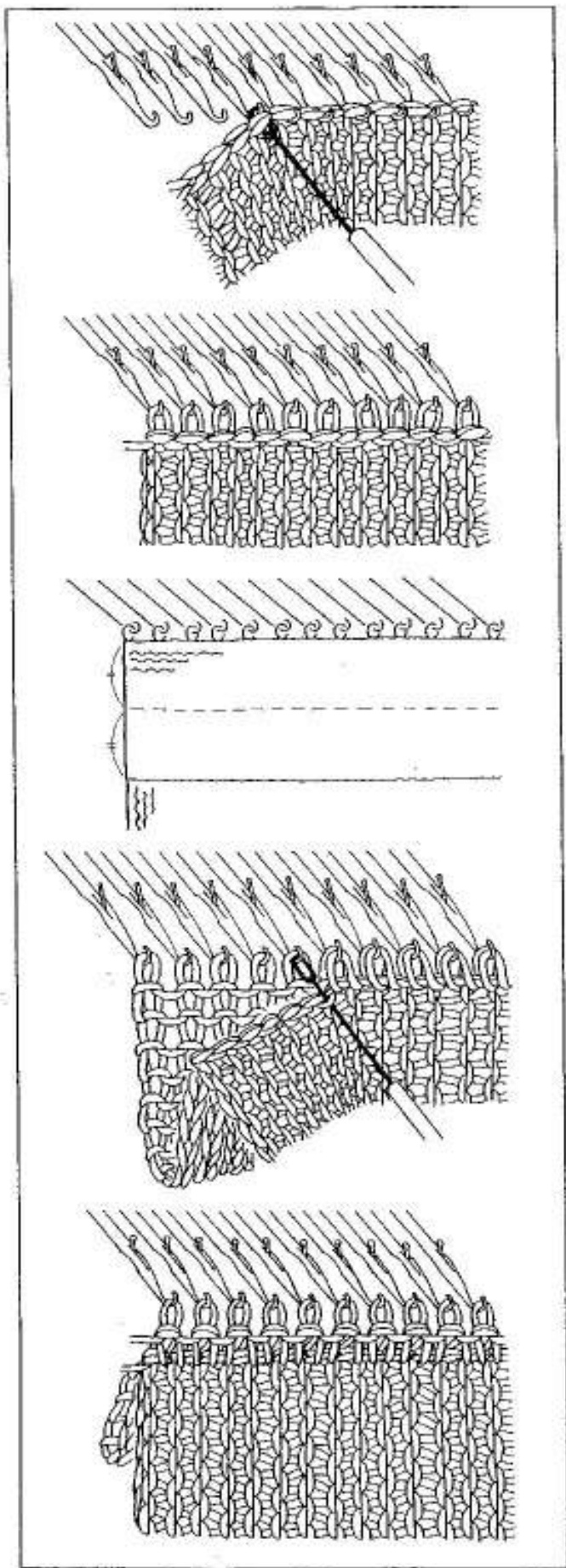

Trimming

Applicable to neckband, border etc.

- (1) With the wrong side facing you, place the stitches of a side edge onto the needles omitting a stitch at appropriate intervals.
- (2) With the main yarn, knit 1 row in stockinet with the Stitch Dial 1 number lower than that used for stockinet.
- (3) Re-set the Stitch Dial to the original number and knit twice the depth of the hem.
- (4) Pick up the sinker loops on the first row and place them onto the needles.
- (5) With the Stitch Dial set 2 numbers higher, knit 1 row.
- (6) Cast off using a Transfer Tool.
(Refer to page 33)

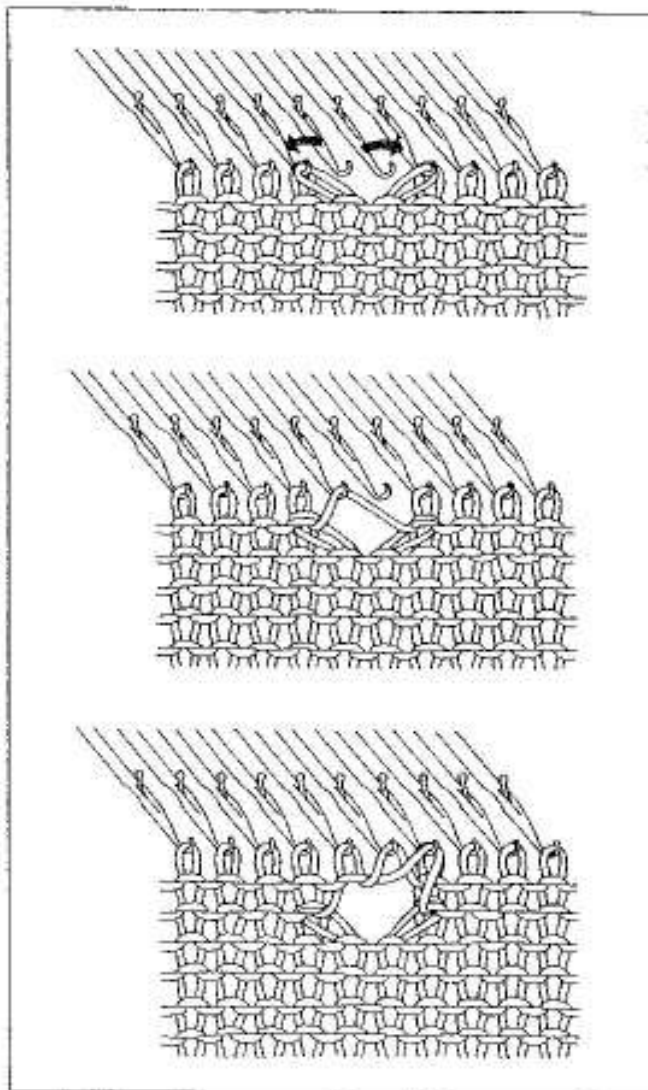

Buttonhole

- (1) Transfer 2 stitches onto their adjacent needles respectively.
- (2) Knit 1 row and remove the hooked yarn from the right side needle.
- (3) Knit 1 row.
Pick up the yarn crossing above and place it onto the needle.
- (4) Continue to knit up to the next buttonhole.

When making buttonholes on a double border, adjust the number of rows or stitches in between the inside buttonholes and outside buttonholes so that they correspond when the border is folded.

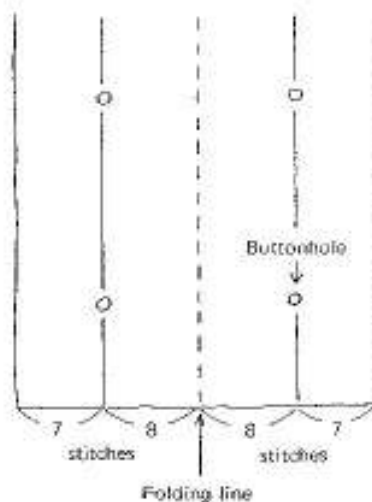
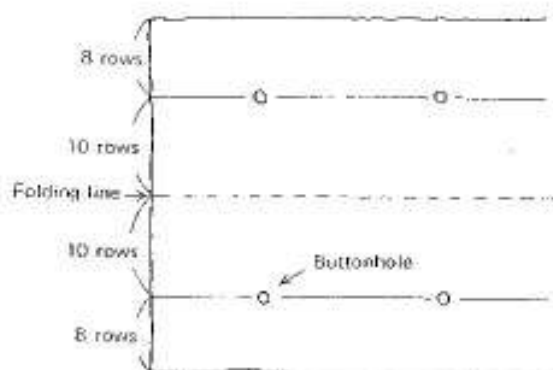

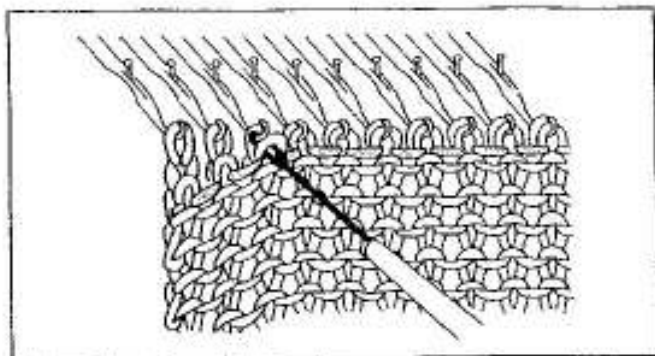

Joining

Joining on the machine

This is used for joining shoulders, joining a waistband to the waist edge, or joining a neckband to the neck edge, etc.

Pick up the stitches from the fabrics to be joined with the right side facing each other, and place them onto the same needles.

Knit 1 row with the Main Carriage, and cast off using the Automatic Linker or a Tappet Tool (refer to page 32).

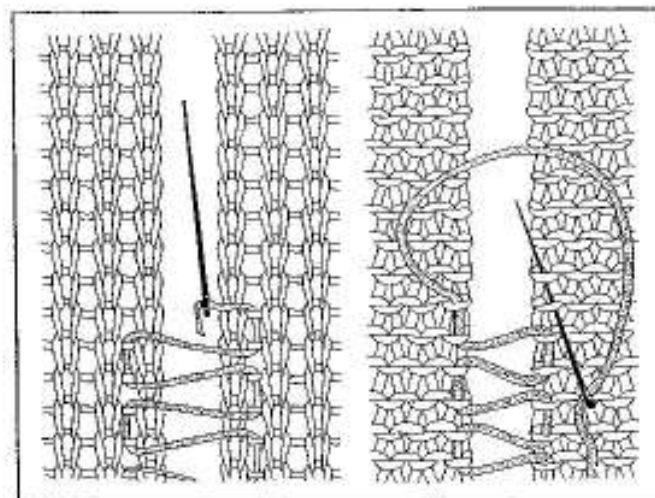

Blind stitch

This is used for joining side seams.

With the right side of both fabrics facing you, pick up two sinker loops together between the last two stitches from the side edges alternately, as illustrated.

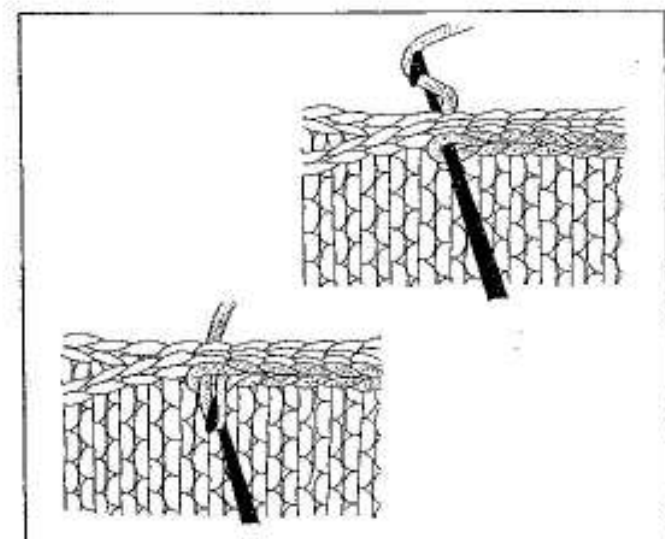

Slip stitch

This is used for setting in the sleeves or joining side seams.

Place the fabrics to be joined with the right side facing each other. Insert the Crochet Hook into the edge stitches and catch the yarn as shown.

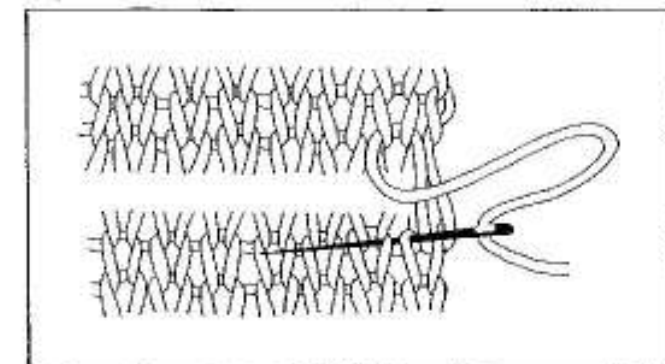

Grafting

This is used for joining two open stitches, where ridges formed by seaming should be soft to the touch.

Align both fabrics as shown and thread the knitting yarn through the stitches with the Tapestry Needle.

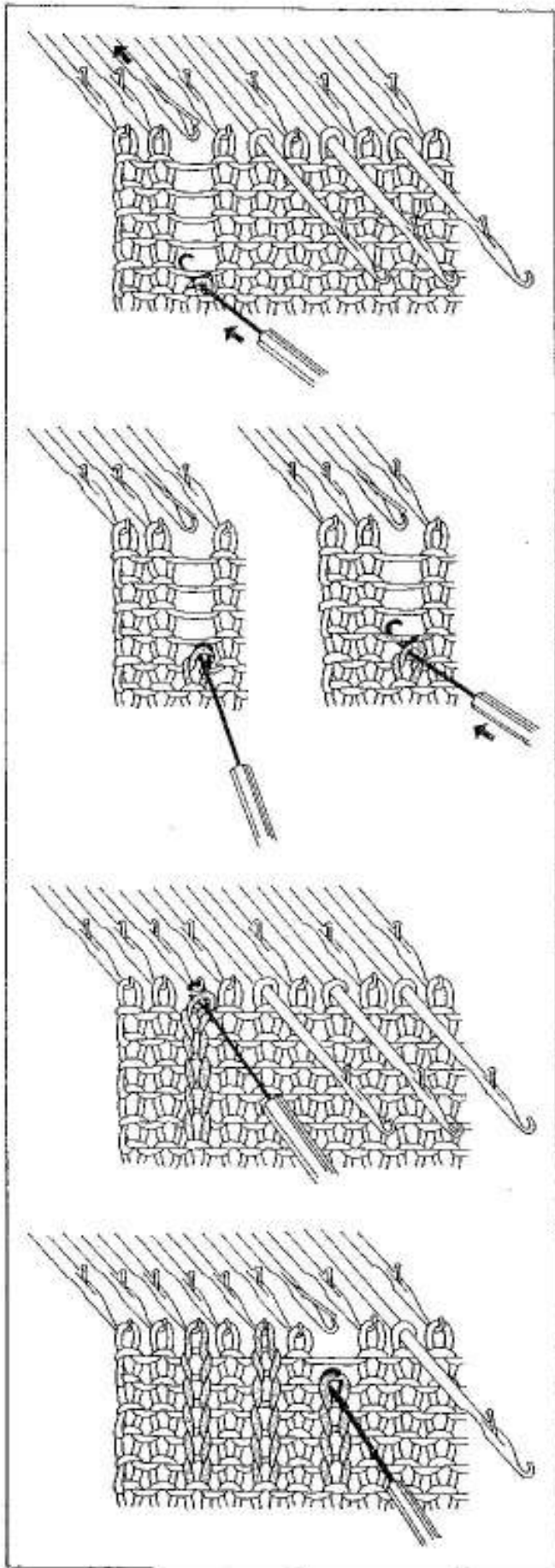

K1, P1, rib

With waste yarn, cast on, and knit several rows.

With the Ravel Cord, knit 1 row.

Using main yarn, knit the number of rows required for the ribbed welt.

(1) Push every alternate needle up into D position. These stitches are to be reformed into purl stitches. Pull the first needle back from D to A position, push the empty needle back into B position. Drop the stitch down to the Ravel Cord.

(2) From the rear hook the bar of the first stitch knitted in main into the tappet tool, and allow the bar to slide behind the latch. Twist the tappet tool to the right to form a loop.

(3) Working from the front, catch the bar of the yarn crossing above into the hook of the Tappet Tool, pull the tool backwards through the loop (stitch) to form a purl stitch. Continue in this manner until all the bars have been latched up.

(4) Place the last stitch back onto the empty needle.

(5) Repeat this procedure over the remaining stitches held on the needles in D position.

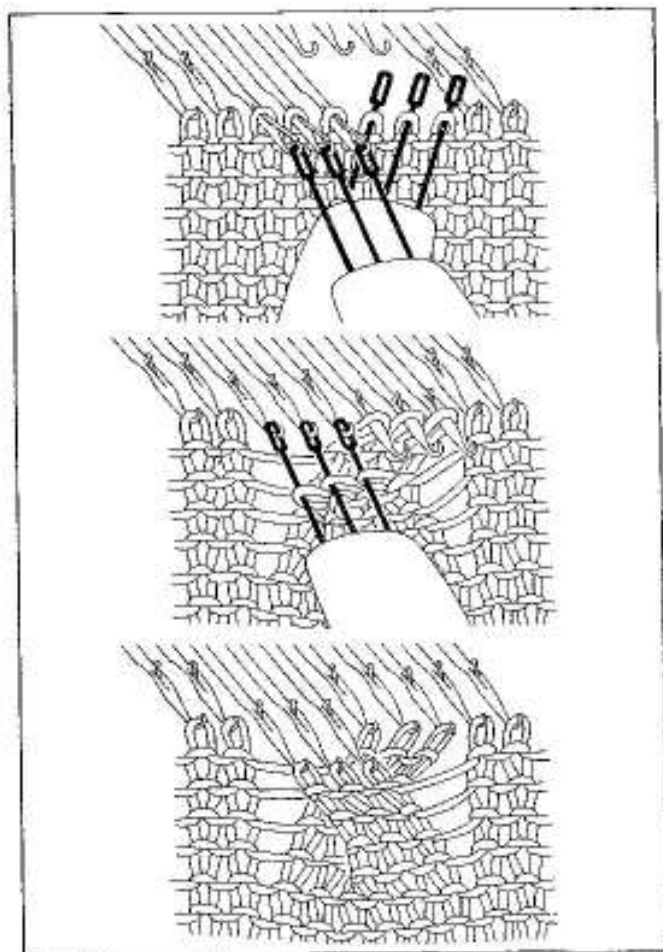

Cable stitch



- (1) Using two treble transfer tools, take three stitches off the needles onto each tool.
- (2) Cross and transfer the three stitches at the right onto 3 empty needles at the left, transfer the remaining three stitches to the empty needles at the right.
- (3) Push these 6 needles up into D position, knit required number of rows.
- (4) Repeat the above procedure.

After three or four patterns have been worked, on either side of the cable drop a stitch down to the beginning of the pattern, insert the Tappet Tool into the stitch and latch up purl-ways. (Refer to page 38).

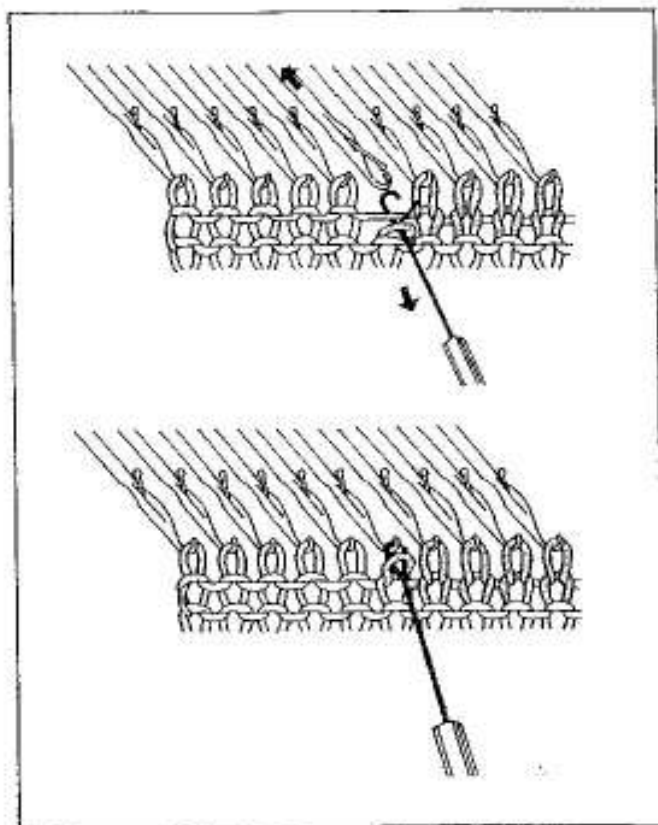

Garter stitch

Set the Stitch Dial to one number lower than that used for stockinet.

- (1) Knit 2 rows.
- (2) Open the latches of all needles and purl all the stitches on the last row using Tappet Tool.
- (3) Repeat these steps.

The Garter Bar helps purl those stitches in a quick and easy way.

It can also be used for transferring multiple stitches at a time, and for various pattern stitches.

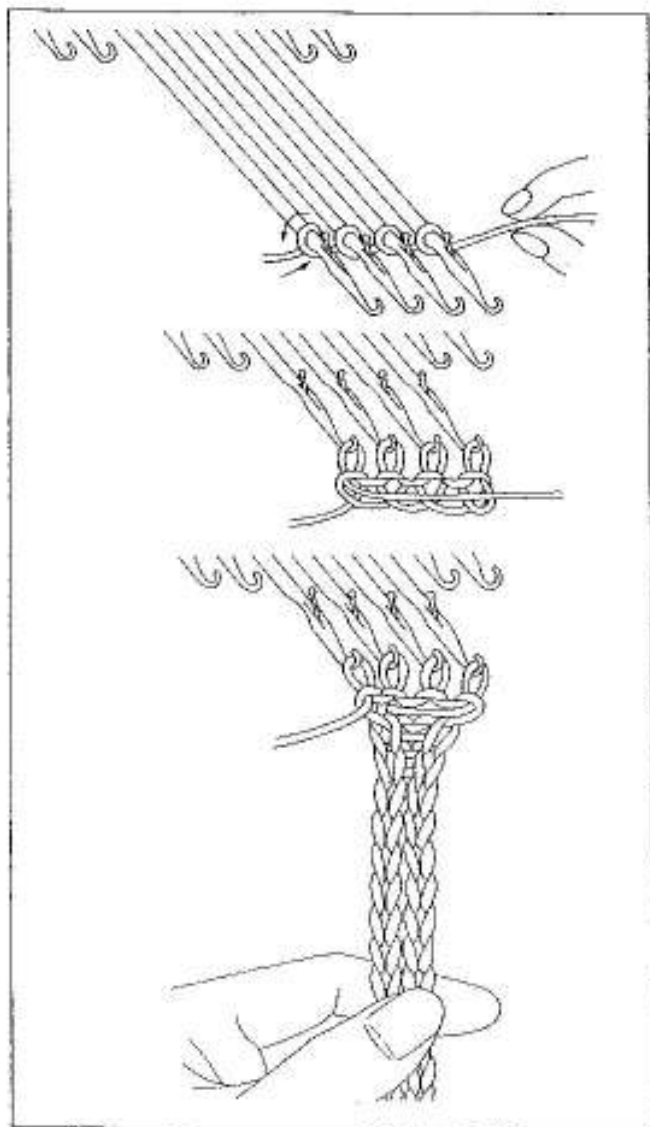

Cord knitting

- (1) Place the Carriage on the right side of the Needle Bed.
Depending upon the thickness of the cord, bring 3-5 needles to D position.
Cast on the stitches by the winding method as illustrated.
- (2) Set the machine as follows,

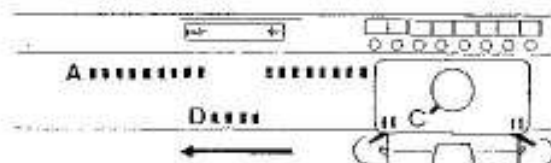

- (3) Move the Carriage back and forth knitting one row, holding the knitting down by hand,
- (4) Continue knitting, pulling the cord down lightly by hand, until the desired length has been achieved.

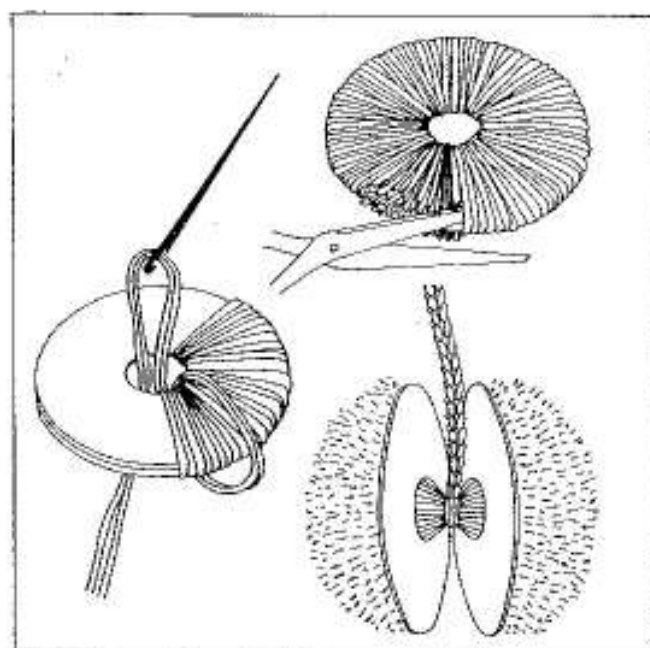

Pompon

- (1) Cut 2 discs out of cardboard with the same diameter for the size of the pompon with a hole of 1/4 of the diameter.
- (2) Thread the Tapestry Needle with yarn for the pompon, wind evenly around the discs until the centre hole is almost filled.
- (3) Insert one scissor blade between the 2 discs and cut all around the yarn.
- (4) Open the discs and with cotton thread, tie the centre together.
Pull out the discs and trim the pompon into shape.

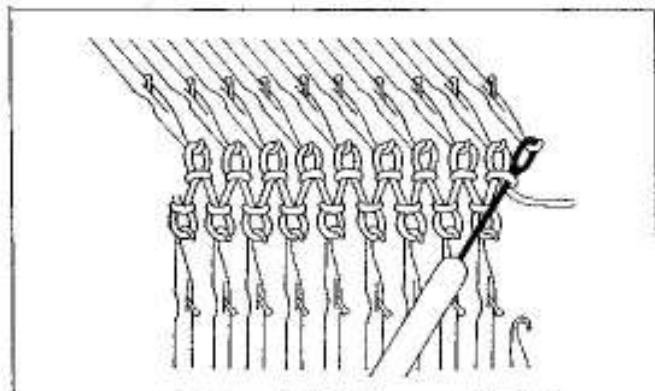

Increase

Increase of single stitch

In case of double rib:

- (1) Push an adjacent Knitter/Ribber needle at A position on Carriage side to B position. Pick loop of stitch below the end stitch and place it onto needle.
- (2) On Ribber/Knitter, push needle in A position up to B position.
- (3) Hang Edge Weight and continue to knit.

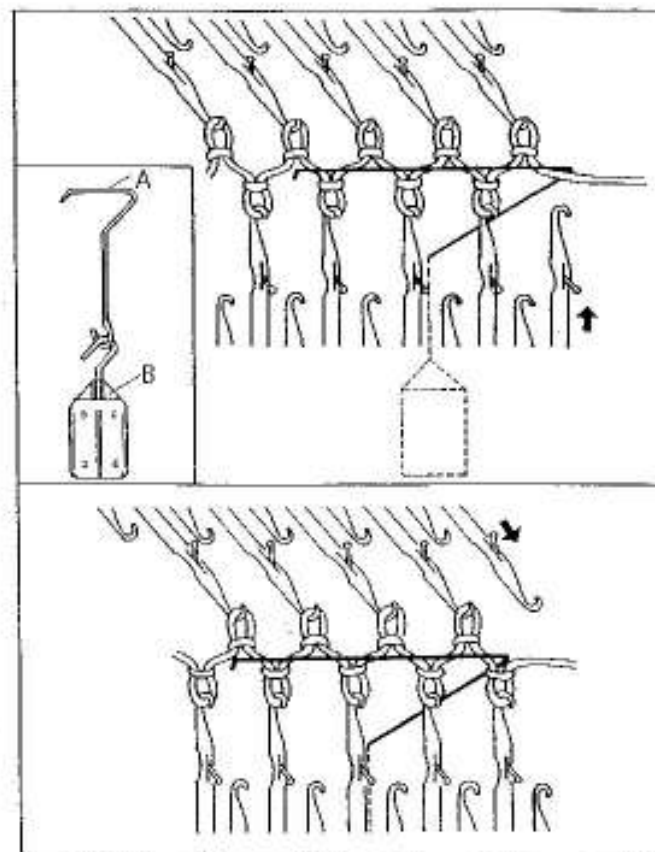

In case of K1.P1. and K2.P2. rib:

POSSIBLE ONLY ON CARRIAGE SIDE.

- (1) On Carriage side push one empty needle opposite the end stitch from A to B position.
- (2) Use Side Hanger "A" with Edge Weight "B" attached, hereafter called Edge Weight. From underneath, insert hook of Side Hanger between Knitter and Ribber Bed, push upwards, and lay hook over zigzag stitches. Ensure yarn is hooked inside Side Hanger.

After approx. 10 rows are knitted, move Edge Weight up in order to obtain better results.

- (3) Continue knitting.

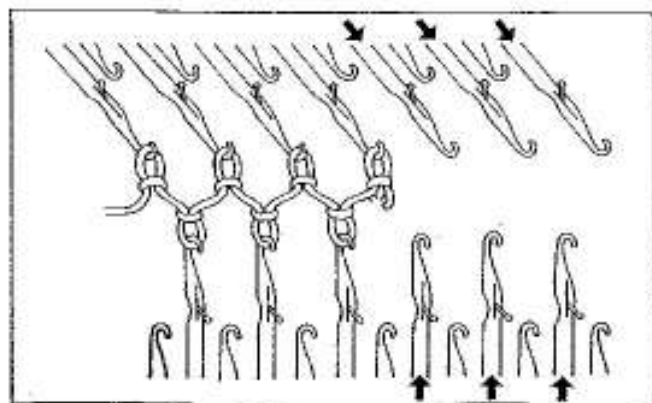

Increase of multiple stitches

In case of K1.P1. and double rib:

POSSIBLE ONLY ON OPPOSITE SIDE OF CARRIAGE.

- (1) On opposite side of Carriage, push required Knitter and Ribber needles up to B position.

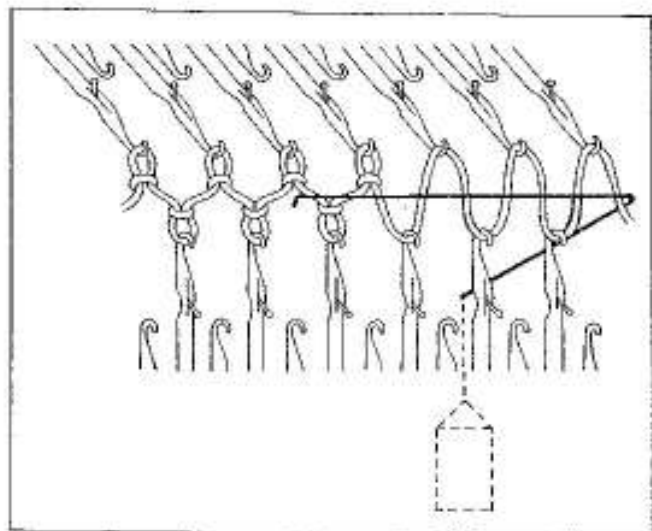

(2) Knit 1 row.

Yarn lies alternately in a zigzag pattern in Knitter and Ribber needle hooks.

(3) Hang Edge Weight and continue to knit.

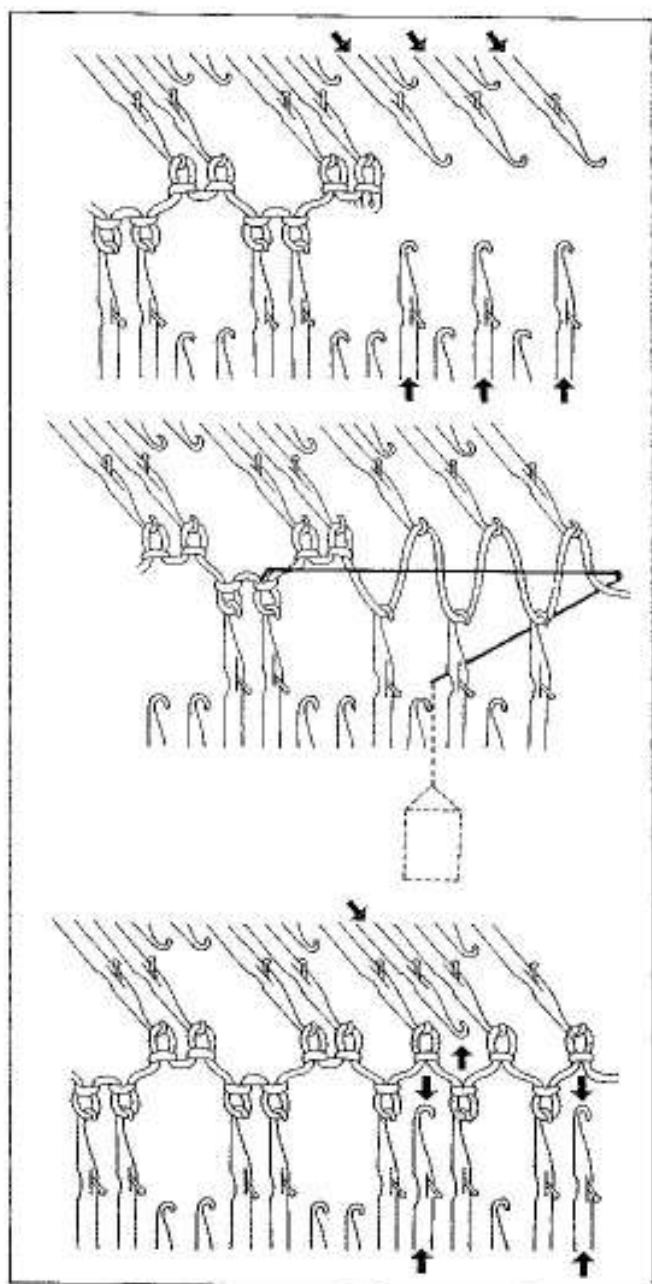

In case of K2, P2, rib:

(1) On the side opposite Carriage, push up required number of needles for increase to B position on both Beds as shown.

(2) Knit 1 row and hang Edge Weight,

(3) Knit 1 row,
Rearrange needles by transferring stitches as arrow-marked.

(4) Push back empty needles to A position.
Continue to knit.

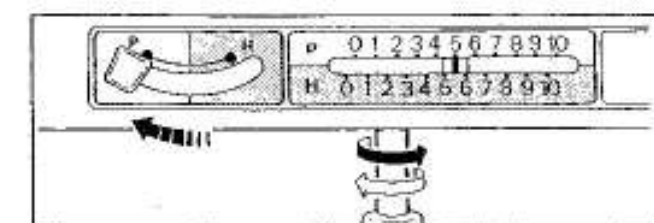
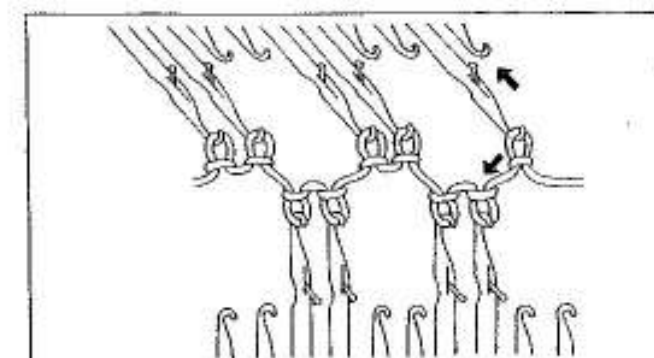
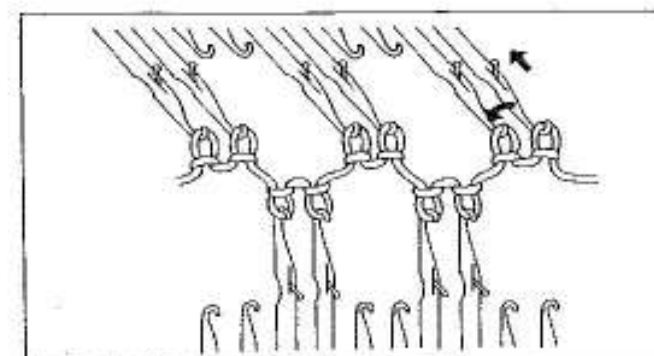
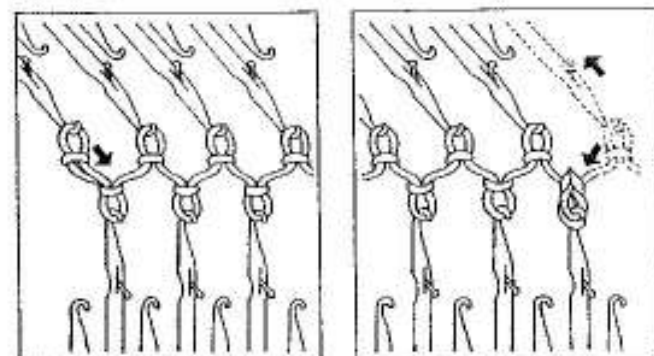
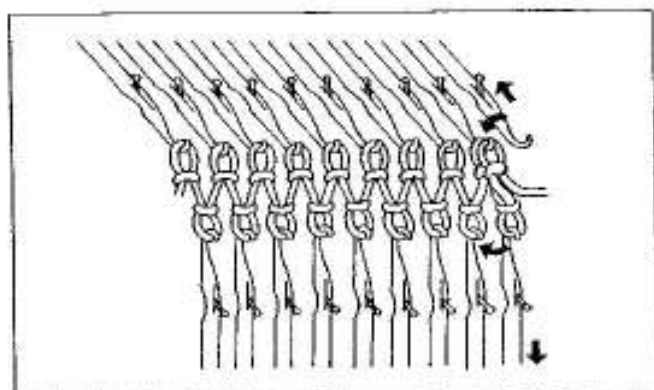

Decrease

Decrease of single stitch

In case of double rib:

- (1) Transfer end stitches on both Knitter and Ribber onto their adjacent inside needles at the same time.
- (2) Push back empty needles to A position. Continue to knit.

In case of K1.P1 rib:

POSSIBLE ON BOTH SIDES.

Using Double-eye Transfer Tool, transfer last stitch either from Ribber to Knitter or vice versa.

Push empty needle back to A position and continue knitting.

In case of K2.P2 rib:

If two end stitches are aligned on Knitter or Ribber, transfer the first end stitch to its adjacent needle.

If one end stitch is only on Knitter or Ribber, transfer the stitch either from Ribber to Knitter or vice versa.

Decrease of multiple stitches

In case of double rib:

- (1) Before transferring stitches, set Half-Pitch Lever to P.

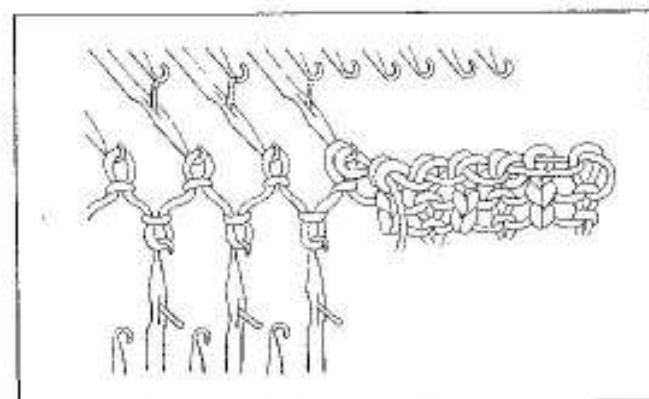
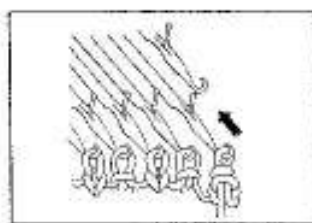
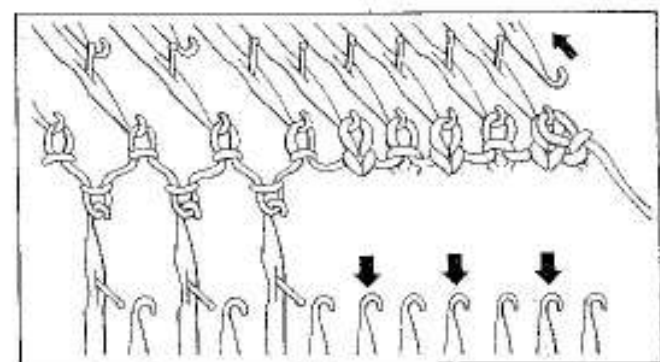
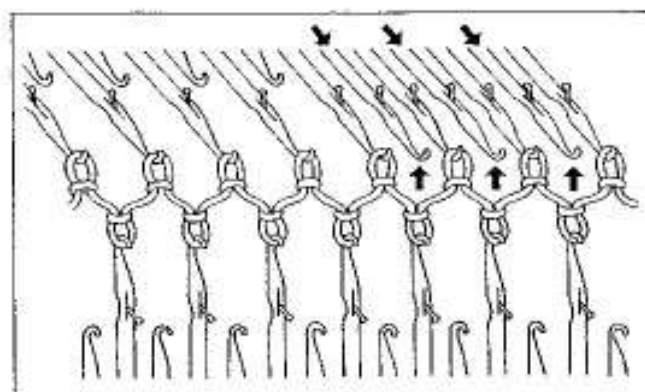
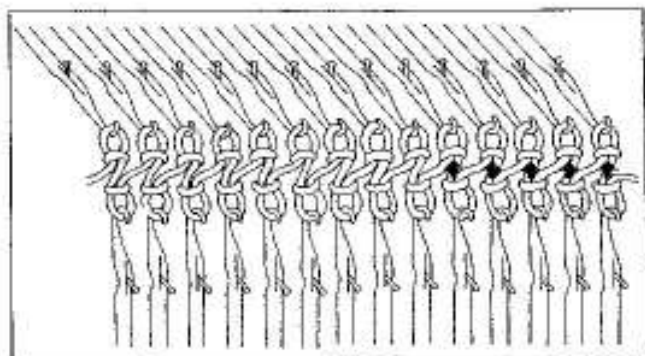

- (2) After decreasing stitches in the same manner as for K1.P1. rib follow the instructions below, "in case of K1.P1. and K2.P2. rib", re-set Half-Pitch Lever to H.

In case of K1.P1. and K2.P2. rib:

POSSIBLE ONLY ON CARRIAGE SIDE.

- (1) Push up required number of empty Knitter needles to B position.
- (2) Transfer stitches from Ribber needles to their corresponding empty Knitter needles.
- (3) Push empty Ribber needles back to A position.
- (4) Transfer end stitch to its adjacent needle and push empty needle back to A position.
- (5) Push end working needle up to D position to have both stitches behind latch, and lay yarn inside needle hook.
- (6) Hold yarn end slightly down and push the needle back to B position.

Repeat steps (4)–(6) until required number of stitches have been decreased.

- (7) Place the last stitch decreased onto adjacent needle.

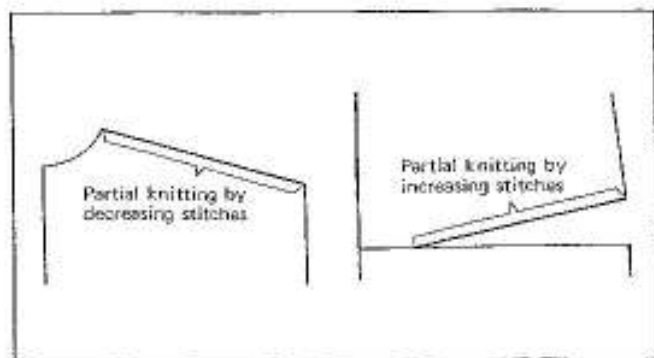

Partial knitting

PARTIAL KNITTING is a practical method for shaping a gentle slope such as a shoulder, back of slacks and so on.

Note:

In case of knitting pushing up end needle to D position like K3. P3. rib, variation swing, pile knitting and drive lace knitting, etc., push up needle to C position since needles in D position can not knit in partial knitting.

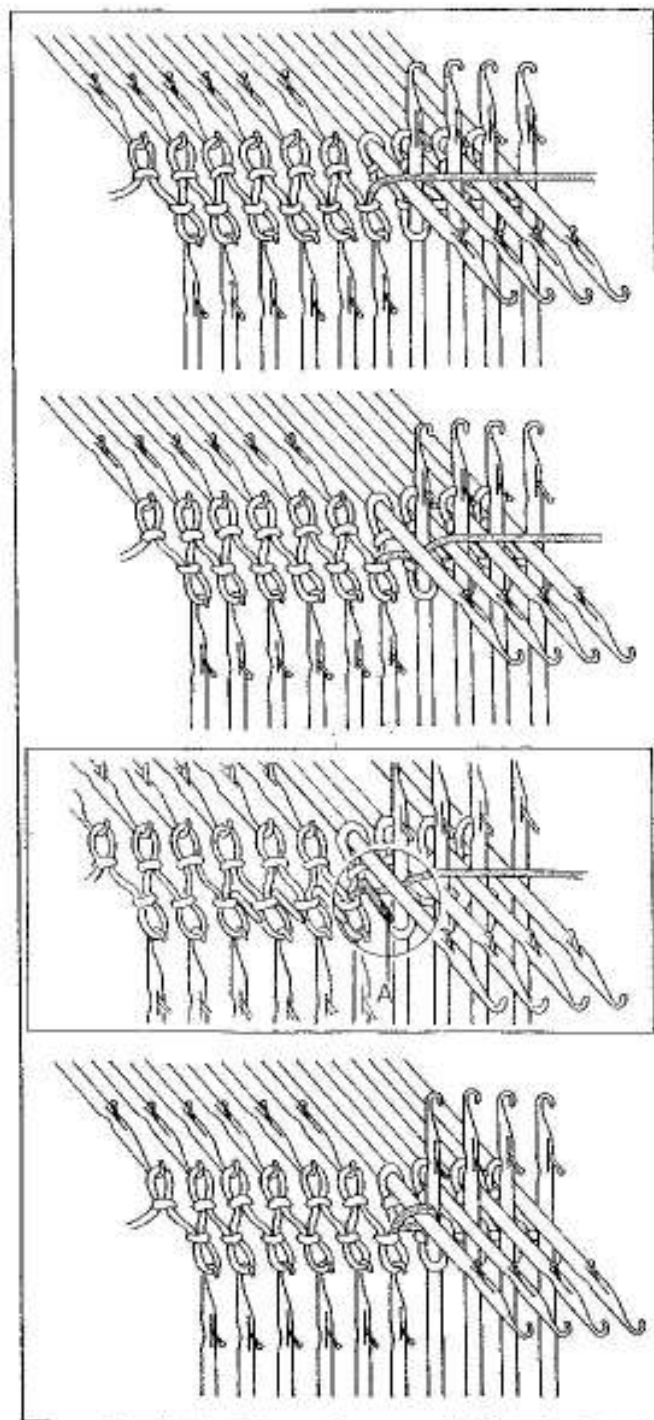

Partial knitting without involving "swing"

This method applies to double rib, K1. P1. rib, K2. P2. rib, K3. P3. rib (wide ribbing), punch tuck rib, pintuck, English and double English rib, etc.

Partial knitting by decreasing stitches.

Set Russel Levers on Knitter and Ribber Carriage to I and — positions respectively.

- (1) On the side opposite Carriage, push up needles to be decreased to D position.
- (2) Knit one row, then yarn will be laid over needles in D position.
- (3) To prevent a hole from being formed in the fabric, bring yarn under the first inside needle in D position. (If partial knitting is required on both sides, apply step (1) before knitting the next row.)

Be sure that yarn is not caught in Sinker Post "A".

- (4) Knit one row.

This completes the first operation of partial knitting.

- (5) Repeat steps (1)–(4).

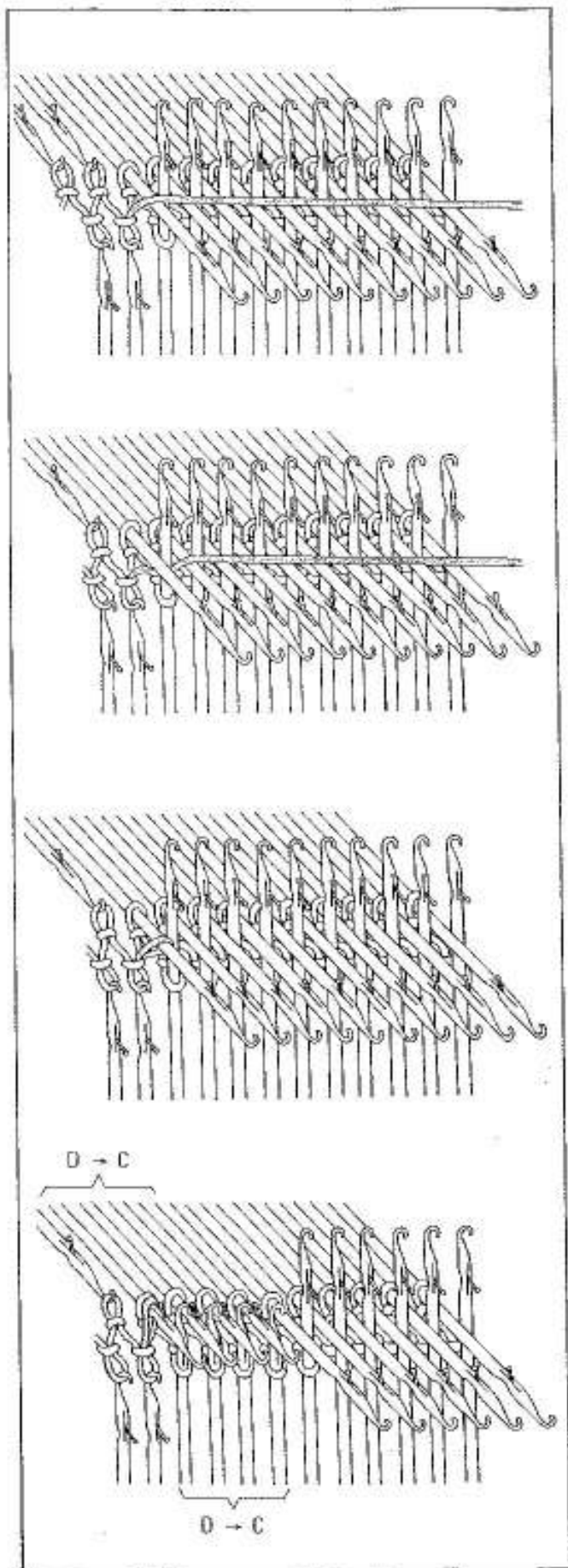

Partial knitting by increasing stitches.

Set Russel Levers on Knitter and Ribber Carriages to 1 and — positions respectively.

- (1) On the side opposite Carriage, push up needles for the width to be shaped by partial knitting to D position.
 - (2) Knit one row, then yarn will be laid over needles in D position.
 - (3) To prevent a hole from being formed in the fabric, bring yarn under the first inside needle in D position.
(If partial knitting is required on both sides, apply step (1) before knitting the next row.)
 - (4) Knit one row.
 - (5) On the side opposite Carriage, push needles in D position to be increased back to C position, and knit one row.
- Note: When knitting in a stitch pattern stitches in D position must be replaced into needle hook, using Transfer Tool.
- (6) Repeat steps (3)–(5).

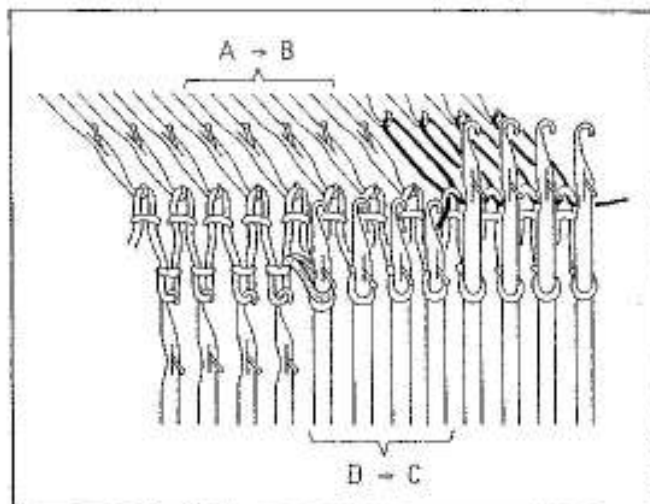
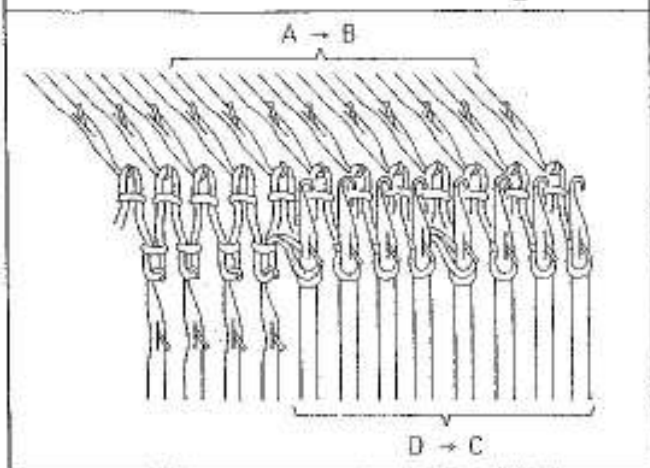
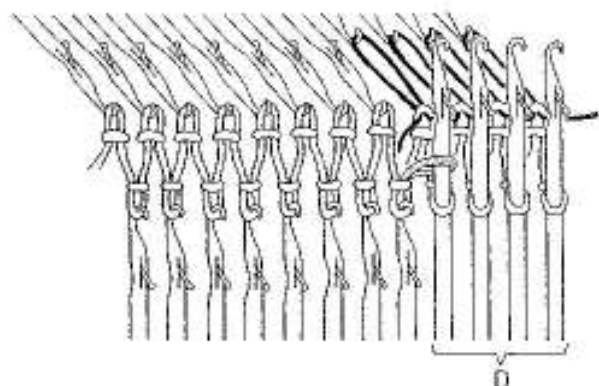
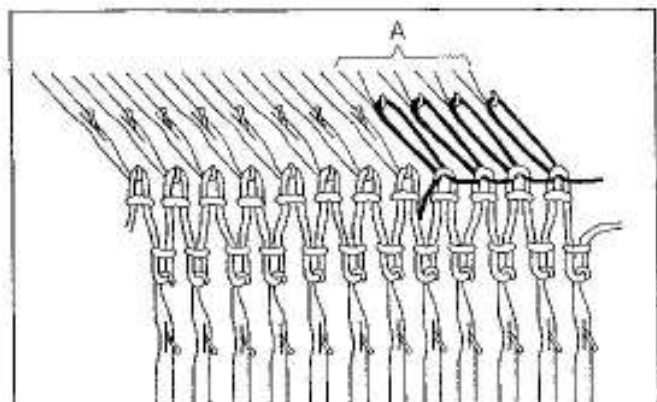

Partial knitting involving "swing"

Knitter needles in D position cross the opposite Ribber needles in D position. Under this condition of needles, you must not swing (by using Swing Handle) Needle Bed, or you will damage the crossed needles. So, a special technique of partial knitting as undermentioned is required for swing English rib, variation swing, herringbone swing and like stitches, all of which involve "swing".

- When working partial knitting in variation swing, knit pushing up 4 or 5 needles in B position to C position.

Partial knitting by decreasing stitches

In the same manner as for partial knitting for stitches without involving "swing", work as follows instead of step (1).

On the side opposite Carriage, to hold stitches on Knitter to be decreased, knit Ravel Cord by hand and push needles back to A position.

Push up corresponding Ribber needles to D position.

At the completion of partial knitting, push needles in D position on Ribber back to C position and replace stitches held on Ravel Cord into hooks of needles on Knitter.

Partial knitting by increasing stitches

On the side opposite Carriage, hold Knitter stitches to be shaped by partial knitting, with Ravel Cord, in A position and corresponding Ribber needles in D position.

At each step in increasing stitches, replace Knitter stitches back into hooks and push corresponding Ribber needles in D position back to C position, before knitting.

Other operations should be carried out in the same manner as decreasing.

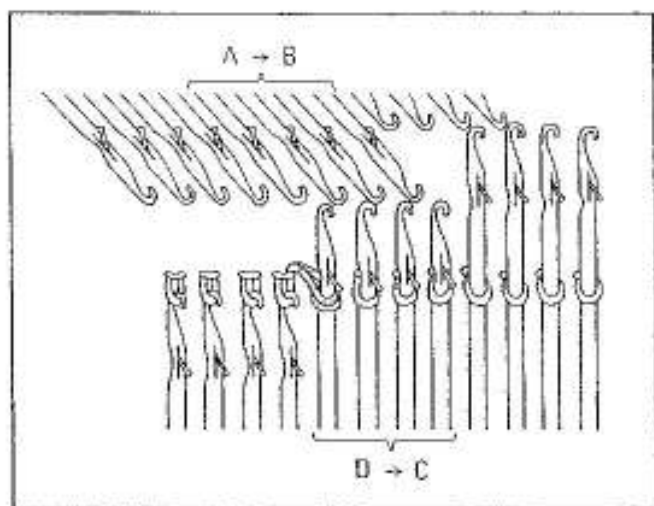
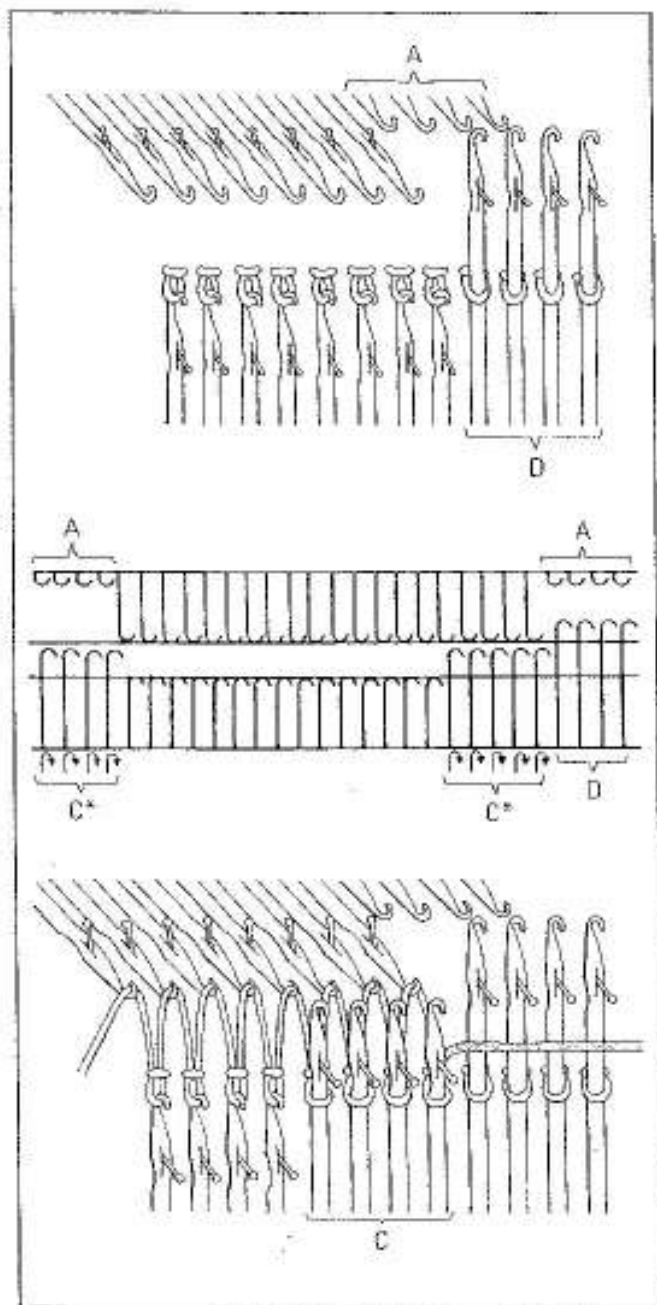

Partial knitting in pile knitting and drive lace knitting.

Set Russel Levers on Knitter and Ribber Carriages to I and — positions respectively.

In pile knitting, start partial knitting after removing stitches on Knitter using P Carriage.

Partial knitting by decreasing stitches

- (1) On the side opposite Carriage, push Knitter needles to be decreased back to A position, and push up Ribber needles to be decreased to D position.
(If partial knitting is required on both sides, push only Knitter needles to be decreased back to A position on the Carriage side.)
- (2) On both sides of Ribber Bed push end 4 or 5 working needles up to D position and then back to C position(*) instead of bringing Ribber needles with P Carriage because it cannot be used in partial knitting.
- (3) Knit one row.
- (4) To prevent a hole, bring yarn under the first inside needle in D position.
(If partial knitting is required on both sides, push up Ribber needles to be decreased to D position on the side opposite Carriage.)
- (5) Work the same manner as done for step (2) and knit one row.
- (6) Repeat steps (1)–(5).

Partial knitting by increasing stitches

On the side opposite Carriage, push Knitter needles back to A position and push up Ribber needles to D position for the width to be shaped by partial knitting.

Push Knitter needles to be increased to B position and push back Ribber needles to be increased to C position. Other operations should be carried out in the same manner as decreasing.

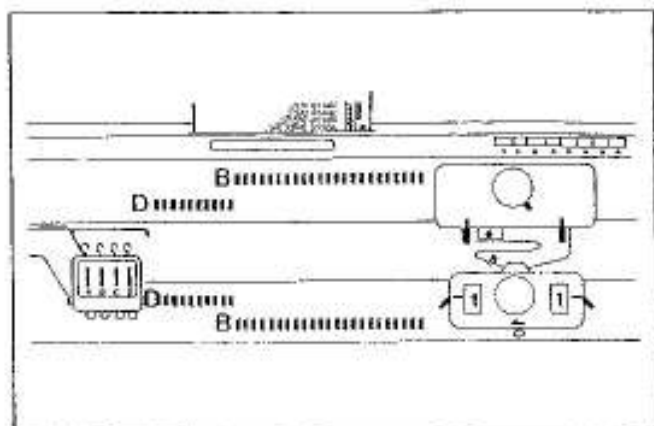

Partial knitting while knitting double jacquard

- * Partial knitting at the right side is worked in the same manner as for double rib.
 - * For partial knitting at the left side, set the Russel Levers as shown below:
 Knitter Carriage..... 1 (both)
 Ribber Carriage..... — (both)
- And follow the instructions below.

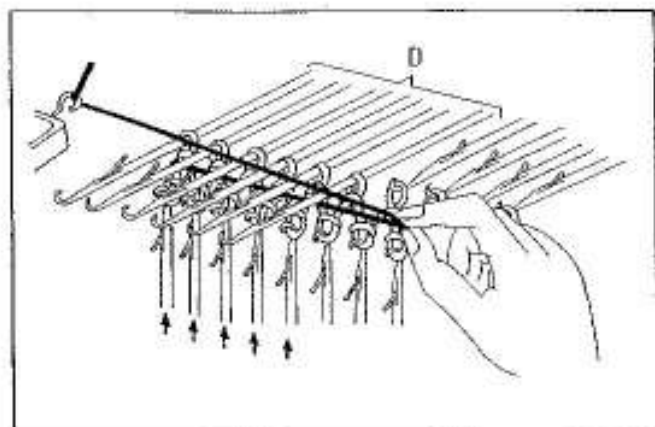

Partial knitting by decreasing stitches

- (1) Leave the Carriage at the right side. Lay the yarn or yarns placed in the Holder between the Needle Beds by pulling them in the opposite direction as illustrated.

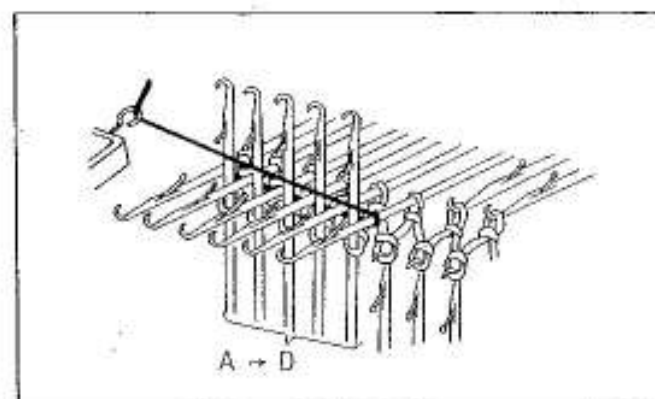

- (2) Push up the needles to be decreased to D position on both Beds so as the yarn is held.
- (3) Knit one row from right to left changing the yarn and knit back.

* Repeat steps (1)–(3).

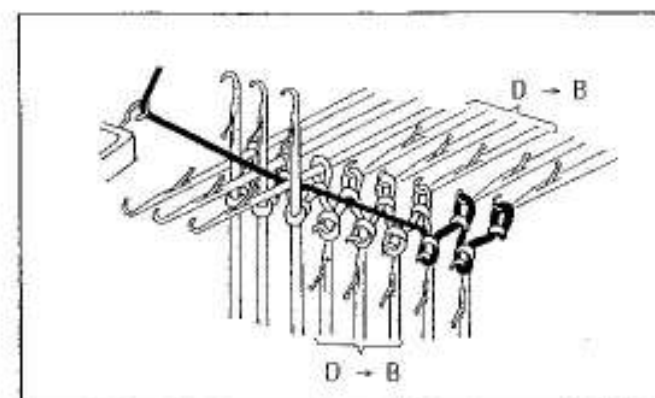

Partial knitting by increasing stitches

- (1) Leave the Carriage at the right side. Using the Transfer Tool, push the needles in D position to be increased back to B position.
- (2) Bring the yarn in the Holder behind the first inside needle of the Ribber and under the first inside needle of the Knitter in D position.
- (3) Knit one row from right to left changing the yarn and knit back.

* Repeat steps (1)–(3).

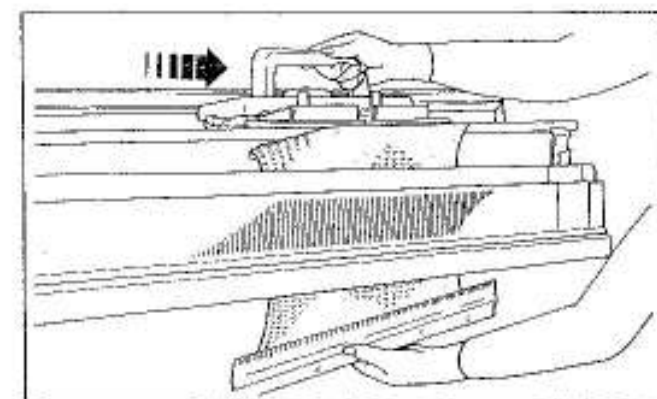
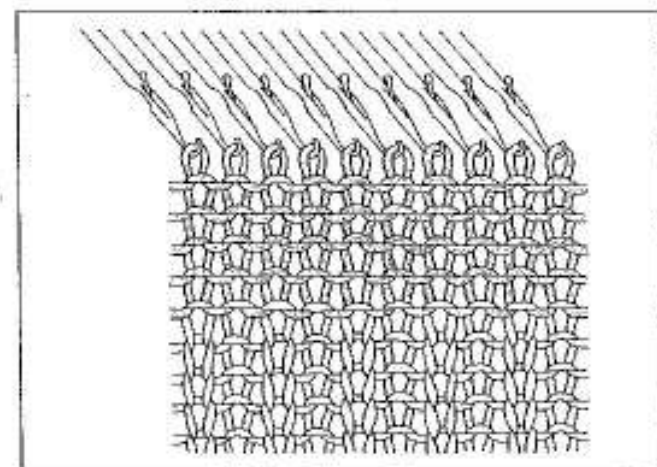
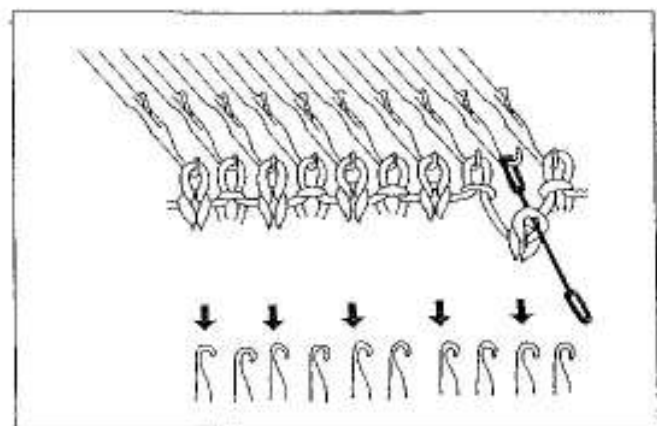
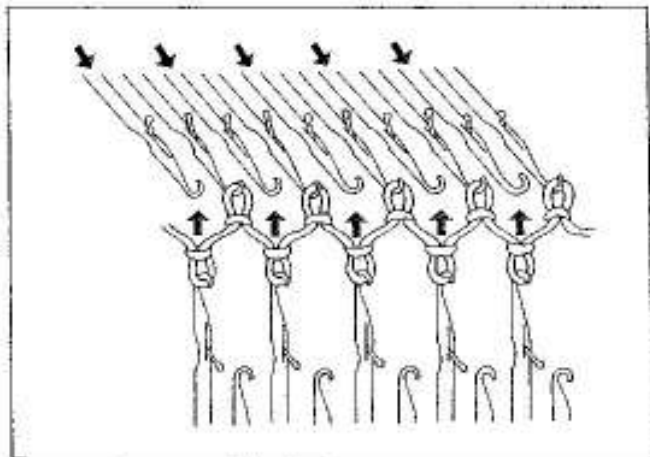

Waste knitting

1. On Knitter, push up empty needles to B position.

2. Transfer stitches from Ribber to corresponding Knitter needles.
Drop Ribber to its lowest position.

3. Exchange Ribber Arm for Knitter Arm and thread a contrast yarn through Yarn Feeder.
Knit 9-10 rows with Stitch Dial 4-5 higher.

4. Remove yarn and Weights.
Set Cam Lever to STOCKINET (A, 0).
Holding Cast-on Comb, move Carriage to remove fabric from machine.

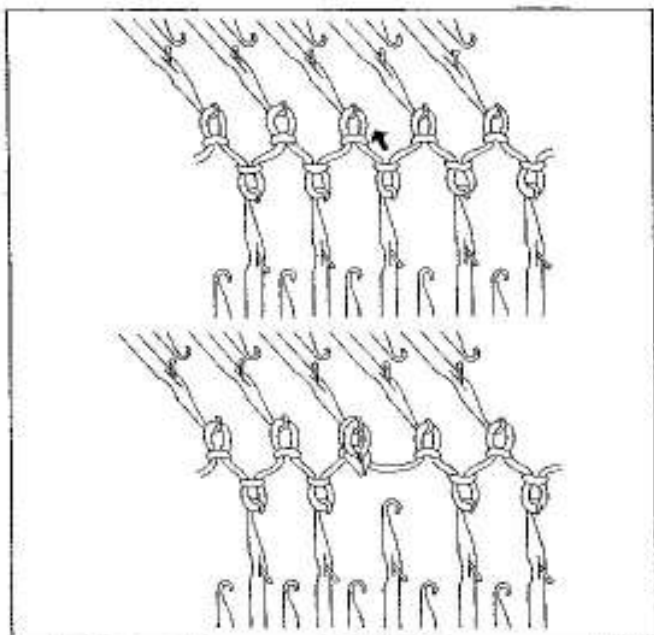

Buttonhole

Single stitch eyelet

- (1) At the point for eyelet, transfer 1 stitch from Ribber to Knitter.
- (2) Leave empty needle in B position. Continue to knit.

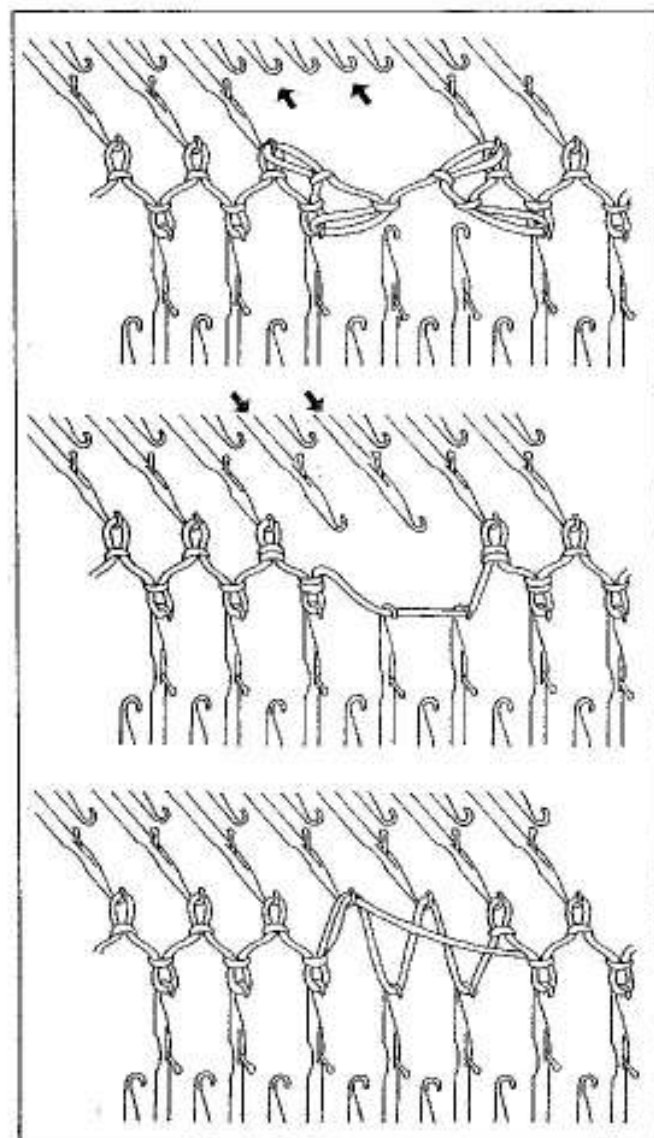

Double stitch eyelet

- (1) Transfer 2 stitches on Knitter onto their adjacent stitches at the point for the buttonhole. Work the same on Ribber.
- (2) Push empty needles on Knitter to A position. Leave empty needles on Ribber in B position.
- (3) Knit 1 row, then on Knitter, push up needles to B position from which stitches were transferred to adjacent needles.
- (4) Knit 1 row.
- (5) Hook hanging yarn on Knitter needle. Continue to knit.

KNITTING GUIDE



It is advisable to knit the Lady's or Man's Pullover as a first try (refer to Page 15) before knitting the other types of garment, as the pullover requires most of the basic techniques necessary for garment making and these techniques are applicable to other garments.

A - 2

LADY'S CARDIGAN

C - 2

CHILD'S CARDIGAN

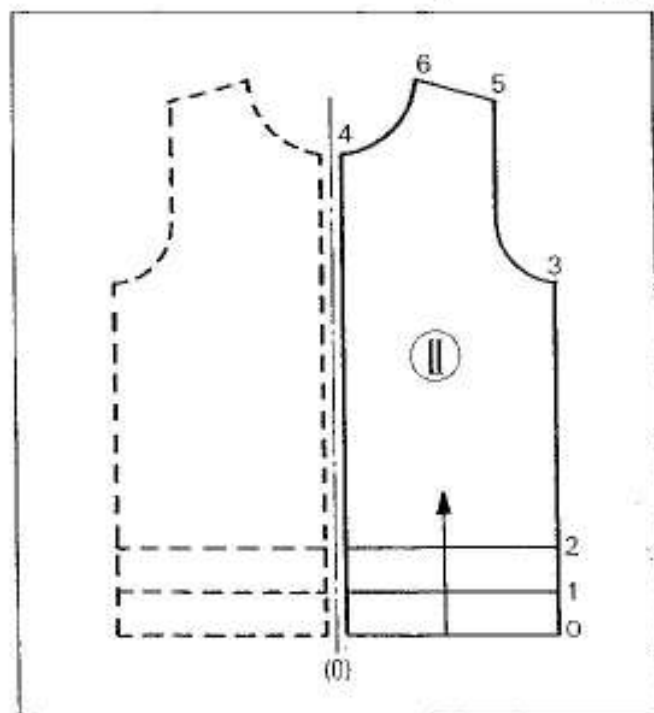

Back - pattern (I)

Knit in the same manner as for the back of the LADY'S PULLOVER (refer to page 15).

Fronts - pattern (II)

- Knit the right and left fronts in a symmetrical pattern.
- At the starting line "0" or "1", cast on stitches on either side of centre(0).
 - Turn up for welt in mock rib or transfer stitches onto knitter in K1.P1. rib.
 - Knit straight up to "3".
 - Knit up to "4", decreasing on the side of armhole.
 - Knit up to "5", decreasing at the neck edge.
 - Knit up to "6", decreasing on the shoulder.

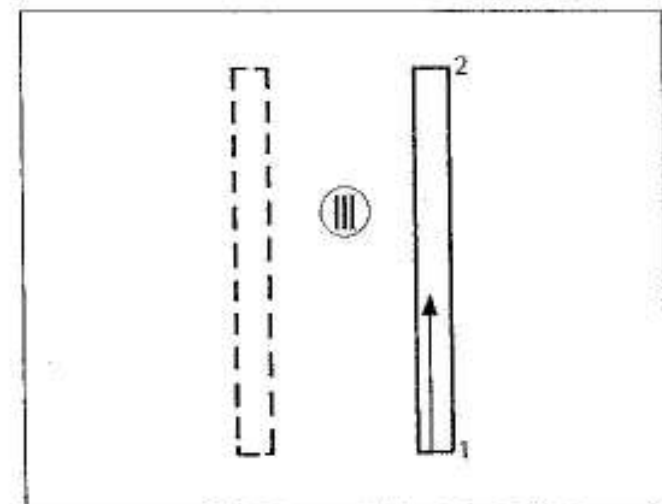

Borders - pattern (III)

Before knitting the border, mark the position for buttonholes on the pattern.

Knit two pieces of the border in the same pattern.

- At the starting line "1", cast on twice the number of stitches as read on the Stitch Scale.
- Knit in K1.P1. rib up to "2".
- Transfer stitches onto knitter and cast off.

Sleeves - pattern (IV)

Knit in the same manner as for sleeve of the LADY'S PULLOVER (refer to page 19).

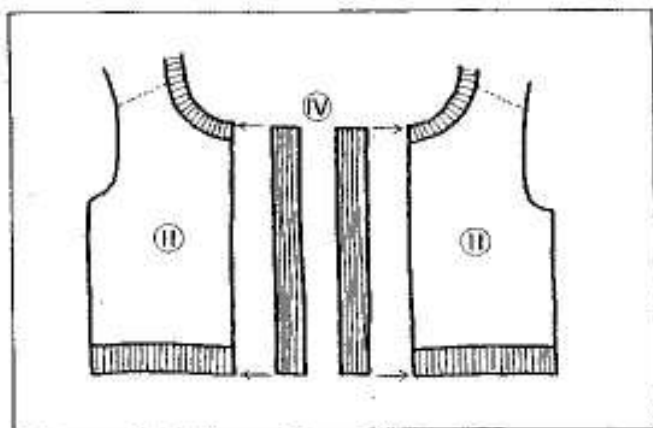

Neckband — pattern (V)

Join both shoulders before knitting the neckband.

In the same manner as for neckband of the LADY'S PULLOVER, knit the neckband and join it to the neck edge (refer to page 20).

Making up

- Join both borders to the front edges. (Illustration)
- Join the side and sleeve seams.
- Set in sleeves.

A — 3

LADY'S RAGLAN SLEEVE PULLOVER

B — 3

MAN'S RAGLAN SLEEVE PULLOVER

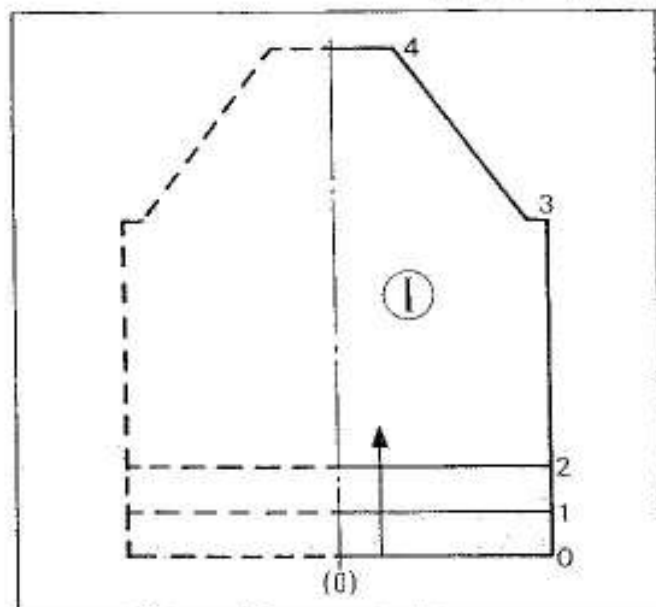

Back — pattern (I)

- At the starting line "0" or "1", cast on stitches on both sides of centre(0).
- Work mock rib or K1, P1, rib up to "2".
- Turn up for welt in mock rib or transfer stitches onto knitter in K1, P1, rib.
- Knit straight up to "3".
- Knit up to "4", decreasing on both sides.
- Cast off.

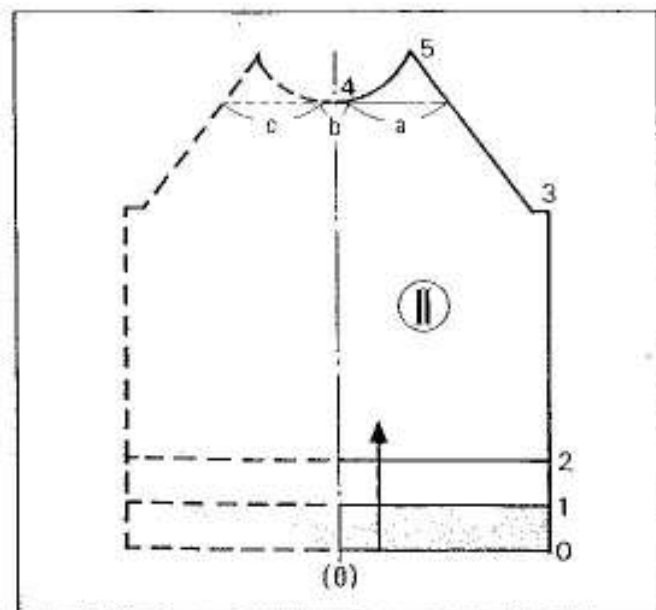

Front — pattern (II)

- At the starting line "0" or "1", cast on stitches on both sides of centre(0).
- Work mock rib or K1, P1, rib up to "2".
- Turn up for welt in mock rib or transfer stitches onto knitter in K1, P1, rib.
- Knit straight up to "3".
- Knit up to "4", decreasing on both sides.
- Push the needles for sections "b" and "c" to holding position.
- For section "a", knit up to "5", decreasing on both sides.
- Cast off the stitches for section "b".
- Push the remaining needles to knitting position, then knit in the same manner as done for section "a" but reversing the shape.

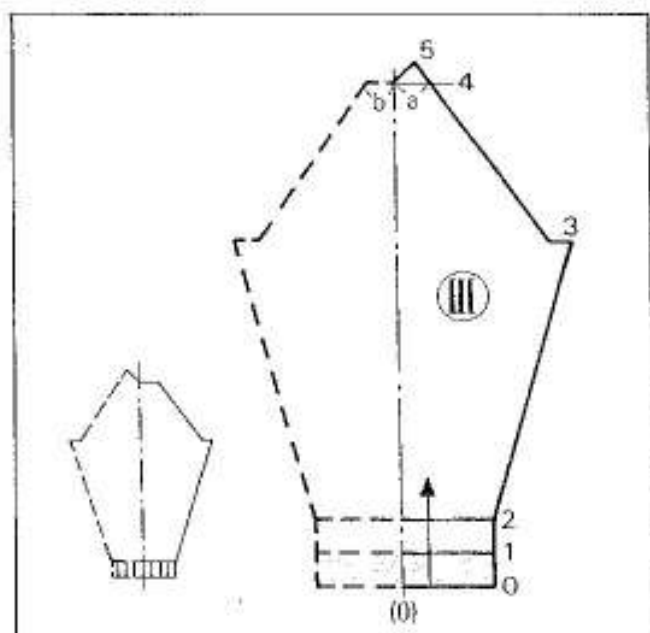

Sleeves – pattern (II)

- At the starting line "0" or "1", cast on stitches on both sides of centre(0).
- Work mock rib or K1.P1. rib up to "2".
- Turn up for cuff in mock rib or transfer stitches onto knitter in K1.P1. rib.
- Knit up to "3", increasing on both sides.
- Knit up to "4", decreasing on both sides.
- Decrease for section "b".
- For section "a", knit up to "5", decreasing on both sides.

Knit the other sleeve on the same pattern but reversing the shape.

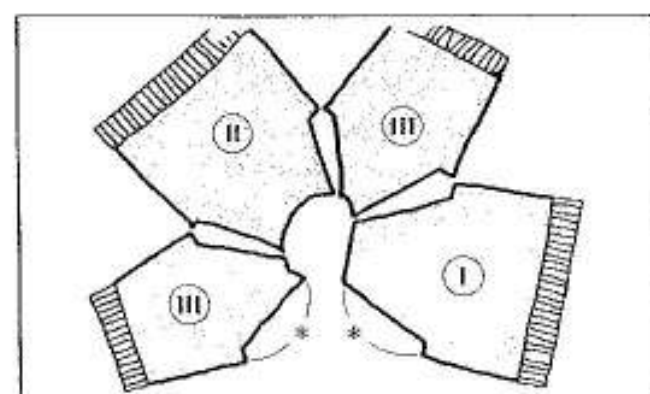

Neckband – pattern (IV)

Before knitting the neckband, join three raglan seams except for the back left raglan line (*), (Illustration)

Knit in the same manner as for neckband of the LADY'S PULLOVER (refer to page 20).

Making up

- Join the remaining raglan seam.
- Join both the side and sleeve seams continuously.

A – 4

LADY'S SKIRT

For 2 panels – pattern (I)

For 4 panels – pattern (II)

Knit two (four) pieces of the same pattern.

- At the starting line "1", cast on stitches on both sides of centre(0).
- Knit up to "2" and turn up for waistband.
- Knit up to "3", increasing on both sides.
- Put yarn marks on both sides.
- Knit up to "4", increasing on both sides.
- Put yarn mark through the row.
- With the Stitch Dial one number lower than the main tension, knit in stockinet up to "5" and cast off.

Making up

- Join the side seams leaving an opening inside the waistband for the elastic.
- Fold in the hem and stitch it down.
- Insert elastic through the waistband.

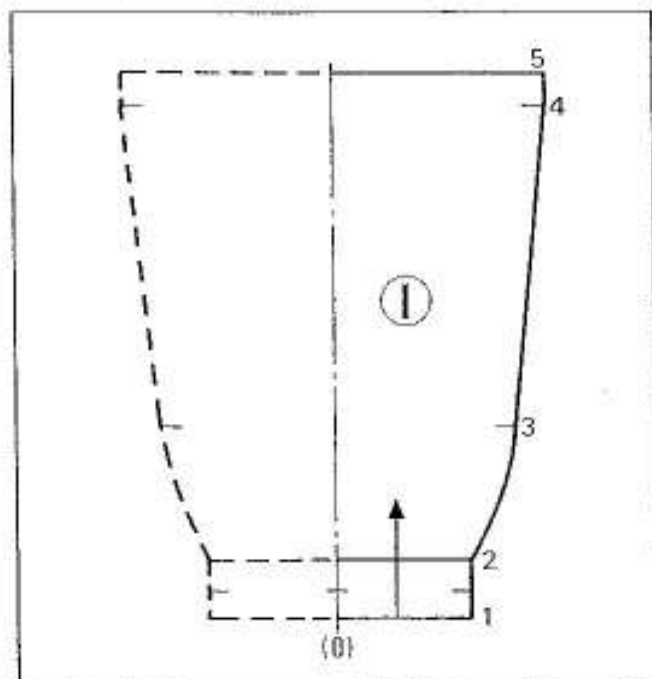

A - 5

LADY'S SLACKS

C - 4

CHILD'S SLACKS

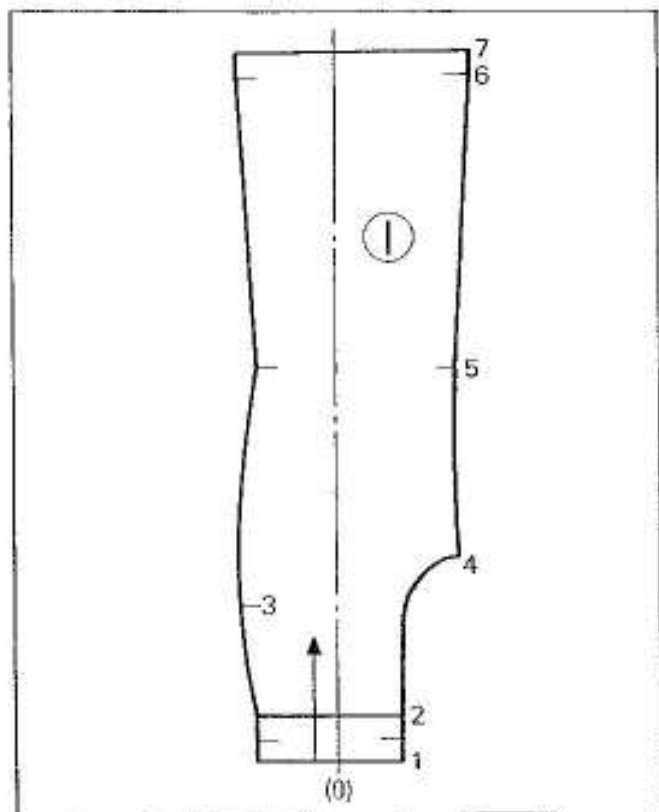

- Knit two pieces each for front and back legs, but reverse shaping.
- Use the Centre Scale.

Front legs - pattern (I)

- At the starting line "1", cast on stitches required respectively on each side of centre(0).
- Knit up to "2" and turn up for waistband.
- Knit up to "3", increasing for the side.
- Put yarn mark at the side edge.
- Knit up to "4", increasing for the crutch.
- Knit up to "5", decreasing on both sides.
- Put yarn marks on both sides.
- Knit up to "6", increasing on both sides.
- Put yarn mark through the row.
- With the Stitch Dial one number lower than the main tension, knit in stockinet up to "7".
- Cast off.

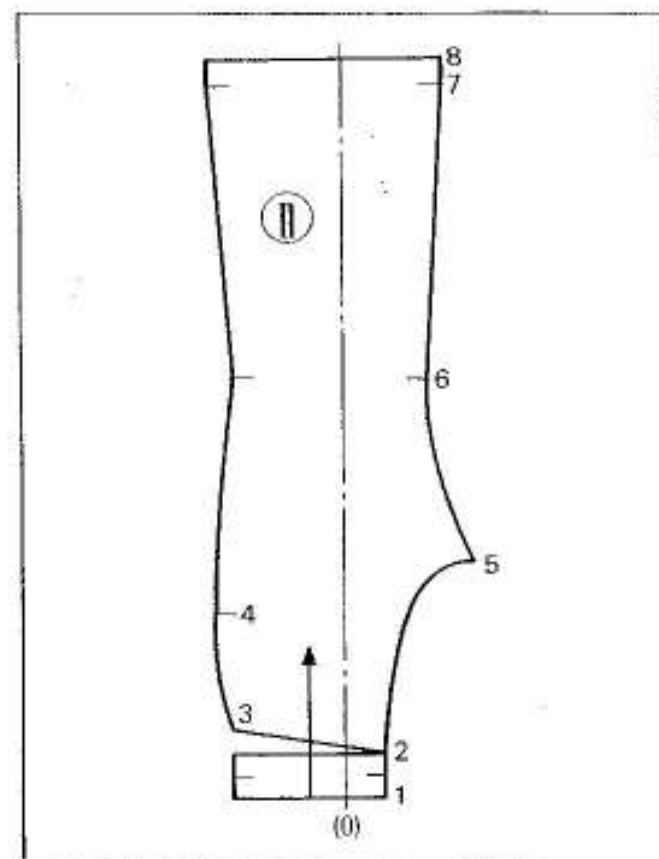
**Back legs - pattern (II)**

- Knit up to "2" in the same manner as done for the front.
- Knit 1 row and push all needles to holding position.
- Work partial knitting by increasing stitches up to "3".
- Knit up to "4", increasing on both sides.
- Put yarn mark at the side edge.
- Knit up to "5", increasing for the crutch.
- Knit up to "6", decreasing on both sides.
- Put yarn marks on both sides.
- Knit up to "7", increasing on both sides.
- Put yarn mark through the row.
- With the Stitch Dial one number lower than the main tension, knit in stockinet up to "8".
- Cast off.

Making up

- Join the centre front and back seams.
- Join the leg seams leaving an opening inside the waistband for the elastic.
- Fold in the hems and stitch them down.
- Insert elastic through the waistband.

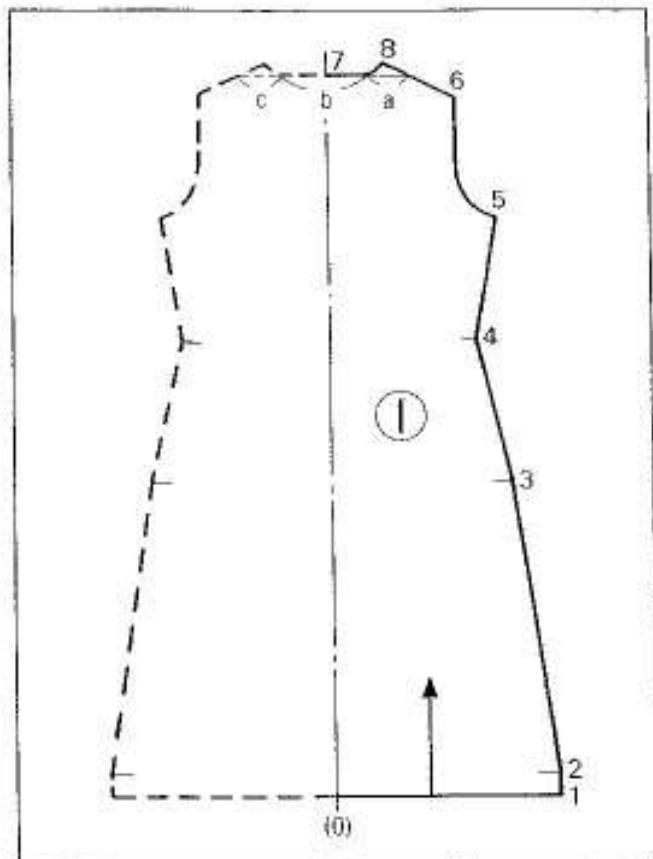
**Back - pattern ①**

- At the starting line "1", cast on stitches on both sides of centre(0).
- With the Stitch Dial one number lower than the main tension, knit in stockinet up to "2".
- Put yarn mark through the row.
- Knit up to "3", decreasing on both sides.
- Put yarn mark on both sides.
- Knit up to "4", decreasing on both sides.
- Put yarn mark on both sides.
- Knit up to "5", increasing on both sides.
- Knit up to "6", decreasing on both sides.
- Knit up to "7", decreasing on both sides.
- Push the needles for sections "b" and "c" to holding position.
- For section "a", knit up to "8", decreasing at the neck edge and on the shoulder respectively.
- For section "b", cast off.
- Push the remaining needles to knitting position, then knit in the same manner as done for section "a" but reversing the shape.

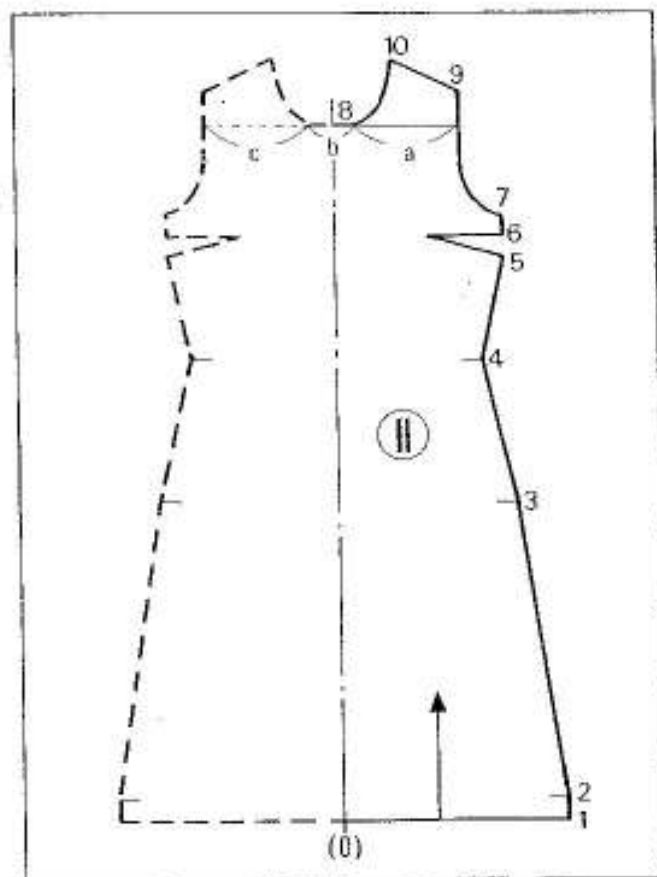
**Front - pattern ②**

- Knit up to "5" in the same manner as done for the back.
- For the bust darts, work partial knitting on both sides up to "6".
- Knit straight up to "7".
- Knit up to "8", decreasing on both sides.
- Push the needles for sections "a" and "b" to holding position.
- For section "c", remove on waste knitting.
- For section "b", cast off.
- For section "a", knit up to "9", decreasing at the neck edge.
- Knit up to "10", decreasing on the shoulder.
- Replace the stitches for section "c" onto the needles, then knit in the same manner as done for section "a" but reversing the shape.

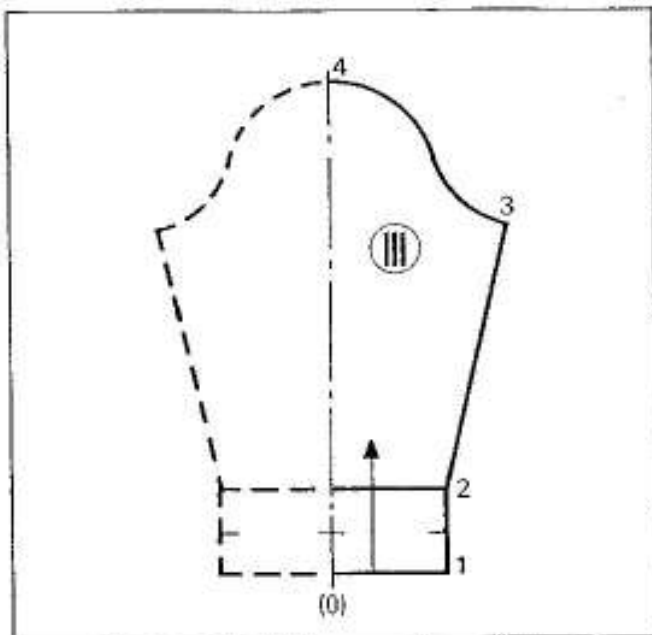

Sleeves – pattern (III)

- At the starting line "1", cast on stitches on both sides of centre(0).
- Work mock rib or K1.P1. rib up to "2".
- Transfer stitches onto knitter in K1.P1. rib and turn up for cuff.
- Knit up to "3", increasing on both sides.
- Knit up to "4", decreasing on both sides.
- Cast off the remaining stitches.

Neckband – pattern (IV)

Join the right shoulder before knitting the neckband.

- At the starting line "1", cast on stitches on both sides of centre(0).
- Work mock rib or K1.P1. rib up to "2".
- Transfer stitches onto knitter in K1.P1. rib and turn up for band.
- Join to the neck edge (refer to page 20).

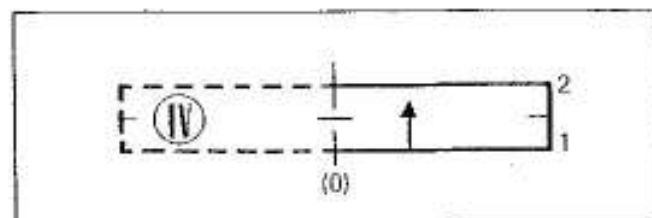

Making up

- Join the left shoulder.
- Join the side and sleeve seams.
- Set in the sleeves.
- Fold in the hems and stitch them down.

B – 2

MAN'S CARDIGAN

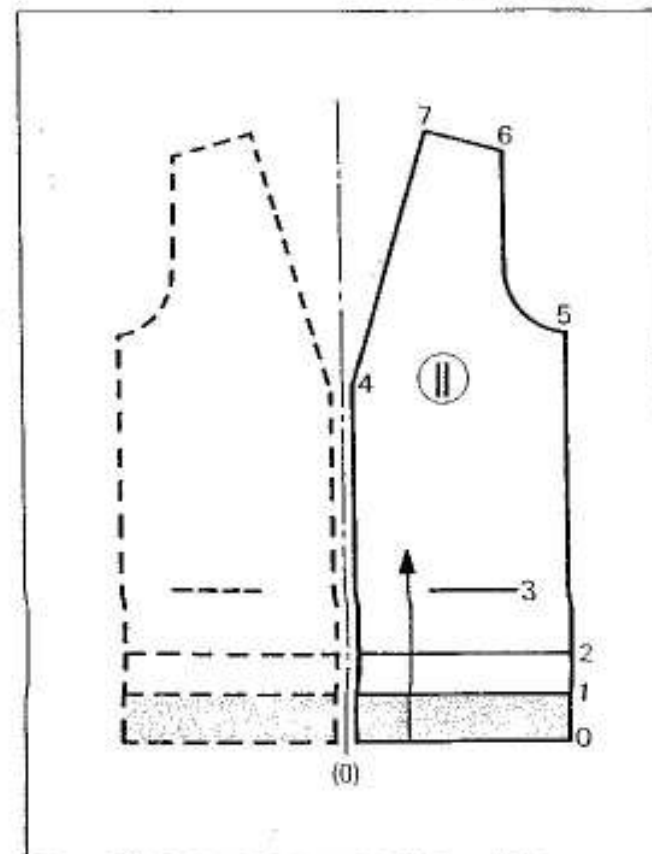

Back – pattern (I)

Knit in the same manner as for back of the MAN'S PULLOVER (refer to page 15).

Fronts – pattern (II)

Knit the right and left fronts in a symmetrical pattern.

- At the starting line "0" or "1", cast on stitches on either side of centre(0).
- Work mock rib or K1.P1. rib up to "2".
- Turn up for welt in mock rib or transfer stitches onto knitter in K1.P1. rib.
- Knit straight up to "3".
- Knit a contrast coloured yarn by hand for the pocket opening.
- Knit straight up to "4".
- Knit up to "5", decreasing at the neck edge.
- Knit up to "6", decreasing on both sides.
- Knit up to "7", decreasing on the shoulder.

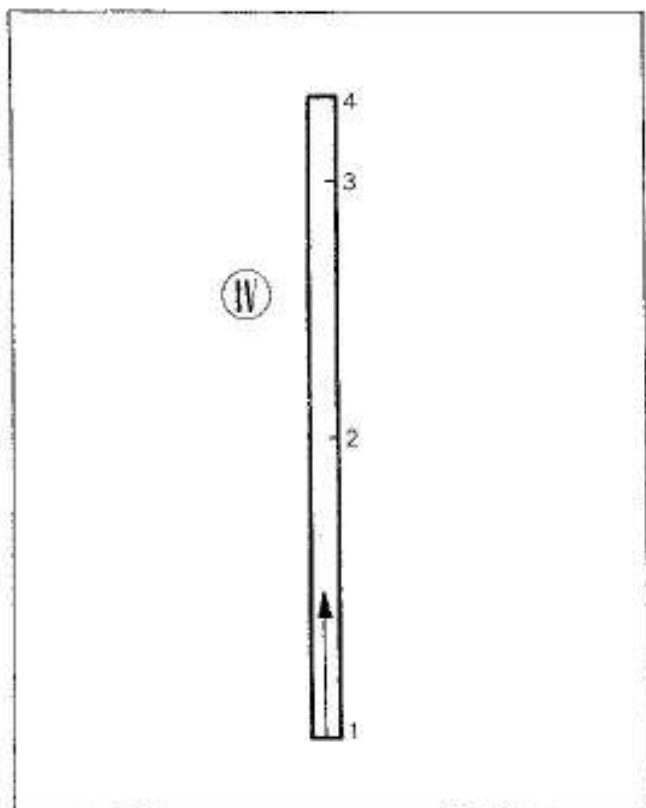

Sleeves – pattern (III)

Knit in the same manner as for sleeve of the MAN'S PULLOVER (refer to page 19).

Border – pattern (IV)

- Space out and mark buttonhole positions between "1" and "2".
- At the starting Line "1" cast on twice the number of stitches read on the stitch scale.
- Knit in K1,P1, rib up to "4" making buttonholes where marked and putting yarn marks at "2" and "3".
- Return the Pattern Paper to "1".
- Without yarn marks or buttonholes, knit up to "4".
- Transfer stitches onto knitter and cast off.

Fold the Border Band in half lengthways and place yarn marks on the second half to correspond with the first half. (Illustration)

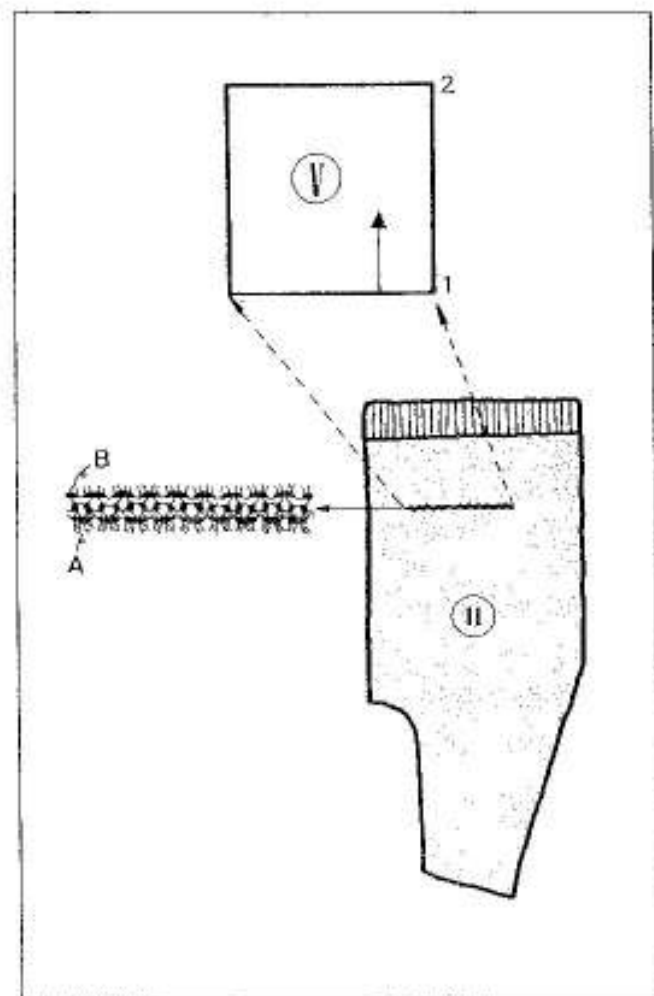
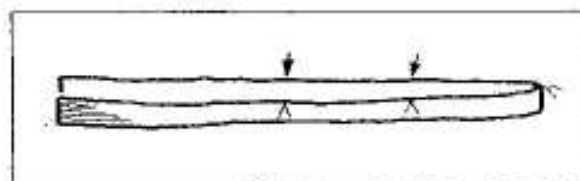

Pockets – pattern (V)

Knit two pieces with the same pattern.

- At the starting line "1", push the required number of needles to B position.
- Pick up stitches on the row (A) interlooped with the contrast yarn for the pocket opening. (Illustration)
- Knit in stockinet up to "2".
- Cast off.

Pocket bands – pattern (VI)

Knit two pieces in the same manner.

- At the starting line "0" or "1", cast on stitches on both sides of centre(0).
- Work mock rib or K1,P1, rib up to "2".
- Turn up for band in mock rib or transfer stitches onto knitter in K1,P1, rib.
- Pick up stitches on the row (B) interlooped with the contrast yarn for the pocket opening. (Illustration)
- Knit 1 row with the Stitch Dial 3–4 numbers higher and cast off.

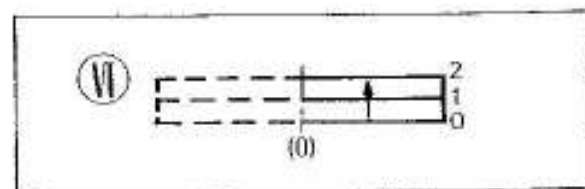

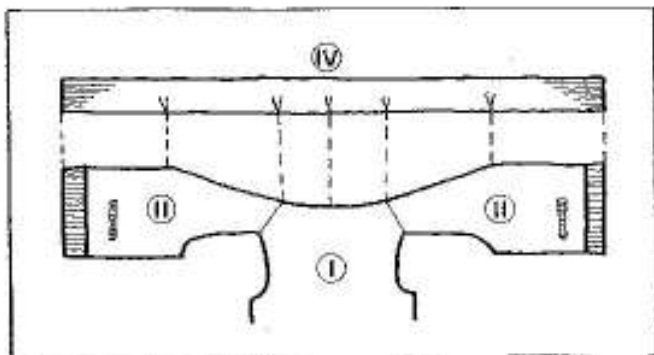

Making up

- Stitch down the pockets and bands.
- Join both shoulders.
- Join the border to the front centre and neck edge. (Illustration)
- Join the side and sleeve seams.
- Set in the sleeves.
- Make buttonholes and sew buttons on the border.

C - 1

CHILD'S PULLOVER

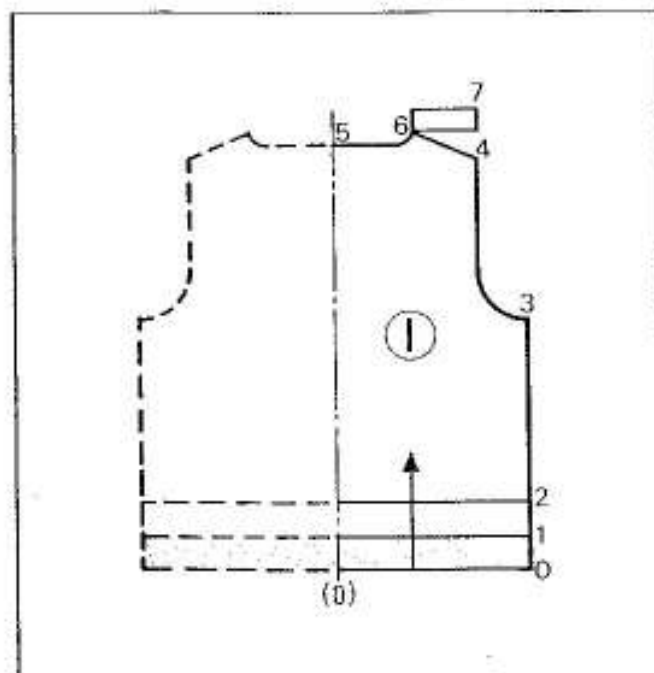

Sizes C, D and E require the same manner as for the LADY'S PULLOVER (refer to page 15). A and B have a shoulder opening and require slightly different techniques for shaping the shoulder. The instructions given here are for making a shoulder opening and joining the neckband.

Back - pattern (I)

In the same manner as for back of the LADY'S PULLOVER (refer to page 15), knit up to neck point "6" by working partial knitting on the left shoulder, then knit the underlap continuously in the following manner.

- Push the needles for the left shoulder to knitting position.
- Knit in stockinet up to "7".
- Put yarn mark through the row.
- Return the Pattern Paper to "6" and knit up to "7" once more.
- Cast off.

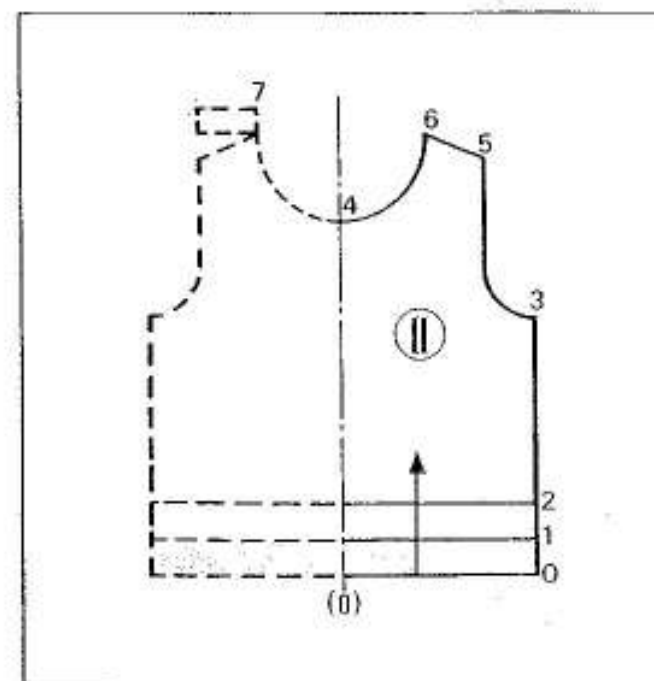

Front - pattern (II)

In the same manner as for front of the LADY'S PULLOVER (refer to page 17), knit up to neck point "6" by working partial knitting on the left shoulder, then knit the facing continuously in the following manner.

- Put yarn mark through the row.
- Knit in stockinet up to "7".
- Cast off.

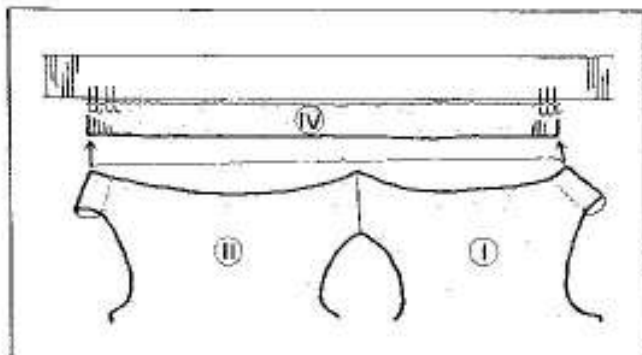

Neckband — pattern (IV)

Before knitting the neckband, join the right shoulder, fold in the facing and underlap at the yarn mark and stitch down onto the shoulder.

Knit in the same manner as for the neckband of the LADY'S PULLOVER (refer to page 20).

After knitting the neckband, join it to the neck edge. (Illustration)

C - 3

CHILD'S RAGLAN SLEEVE PULLOVER

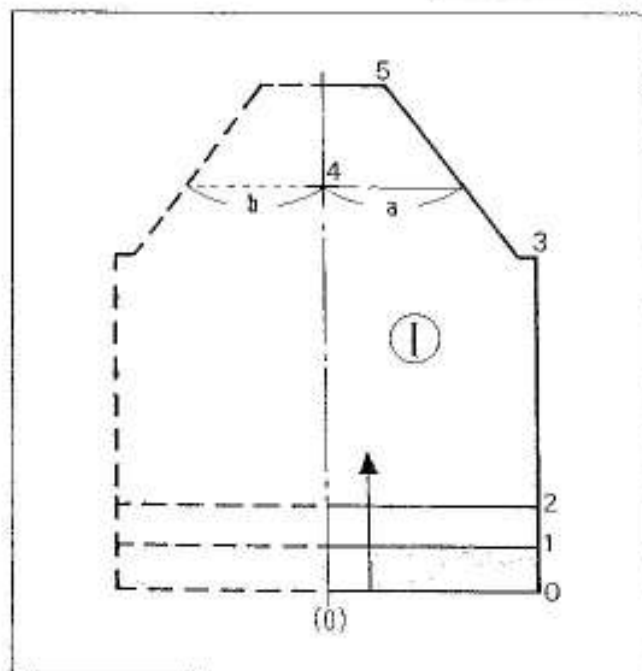

Knit in the same manner as for the LADY'S RAGLAN SLEEVE PULLOVER (refer to page 53) except for the back of size A and B with a back opening.

The instructions given here are for knitting the back and for joining the neckband of size A or B.

Back — pattern (I)

- At the starting line "0" or "1", cast on stitches on both sides of centre(0).
- Work mock rib or K1, P1, rib up to "2".
- Turn up for welt in mock rib or transfer stitches onto knitter in K1, P1, rib.
- Knit straight up to "3".
- Knit up to "4", decreasing on both sides.
- Push the needles for section "a" to holding position.
- For section "b", remove on waste knitting.
- For section "a", knit up to "5", decreasing on the raglan edge, then cast off.
- Replace the stitches for section "b" onto the needles, then knit in the same manner as done for section "a", but reversing the shape.

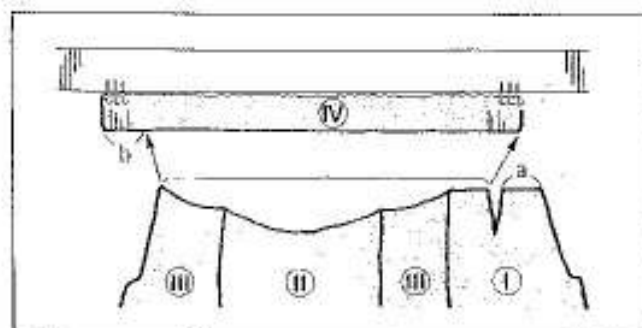

Join the neckband to the neck edge on the machine in the manner as shown. Then revolve the remaining neck edge "a" to the other side "b" and join them in the same manner.

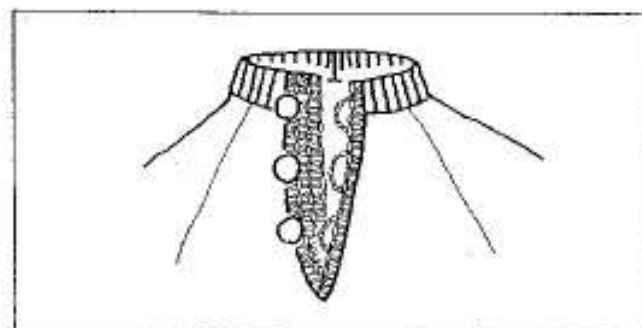

Making up

Trim the back opening in crochet stitch, make loop buttonholes and sew on buttons. (Illustration)

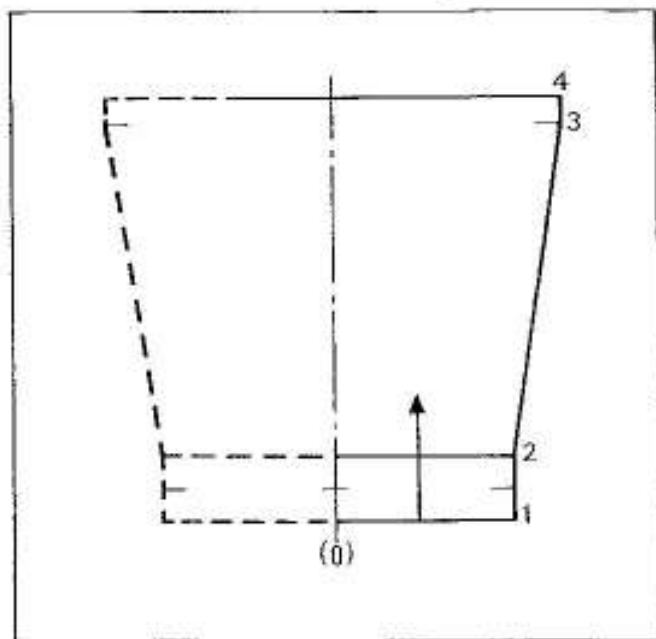

- Knit two pieces of the same pattern.
- At the starting line "1", cast on stitches on both sides of centre(0).
 - Knit up to "2".
 - Turn up for waistband.
 - Knit up to "3", increasing on both sides.
 - Put yarn mark through the row.
 - With the Stitch Dial one number lower than the main tension, knit in stockinet up to "4".
 - Cast off.

Making up

- Join the side seams leaving an opening inside the waistband for the elastic.
- Fold in the hem and stitch it down.
- Insert elastic through the waistband.

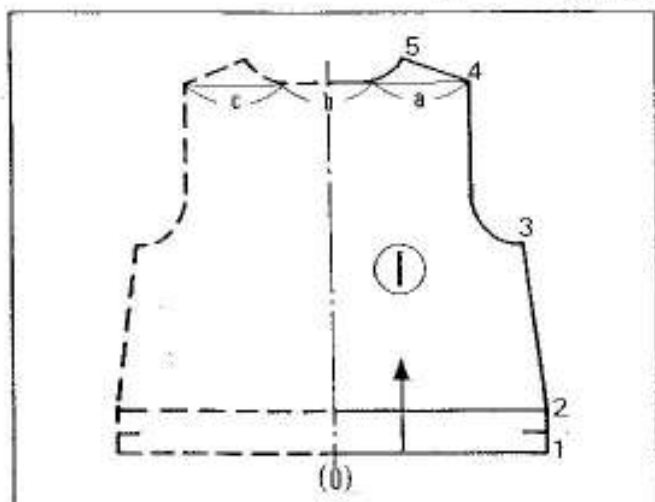
**Back - pattern (I)**

- At the starting line "1", cast on stitches on both sides of centre(0).
- Knit up to "2" and turn up for hem.
- Knit up to "3", decreasing on both sides.
- Knit up to "4", decreasing on both sides.
- Push the needles for sections "b" and "c" to holding position.
- For section "a", knit up to "5" decreasing at the neck edge and on the shoulder respectively.
- For section "c", push the needles to knitting position and knit up to "5" in the same manner as done for section "a" but reversing the shape.
- For section "b", cast off.

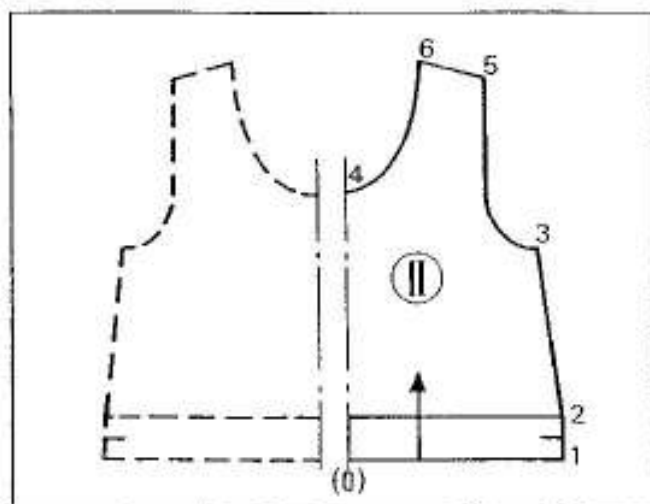
**Fronts - pattern (II)**

- Knit the right and left fronts in a symmetrical pattern.
- At the starting line "1", cast on stitches on either side of centre(0).
 - Knit up to "2" and turn up for hem.
 - Knit up to "3", decreasing on the side edge.
 - Knit up to "4", decreasing on the armhole edge.
 - Knit up to "5", decreasing at the neck edge.
 - Knit up to "6", decreasing on the shoulder.

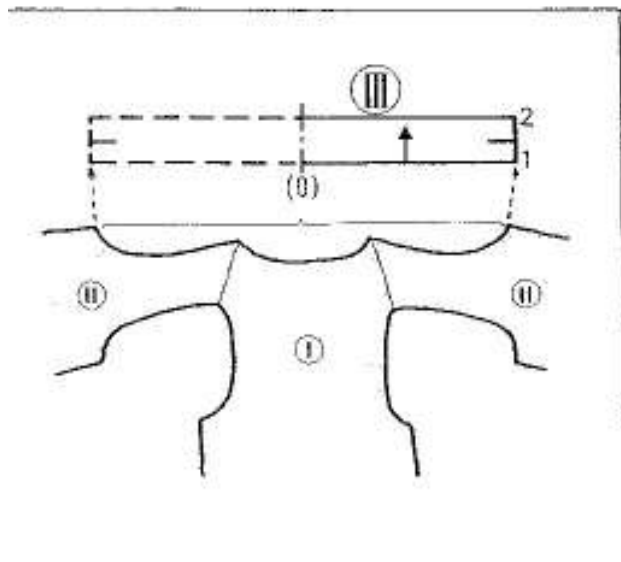

Neckband – pattern (III)

- Join both shoulders before knitting the neckband.
- Set the Stitch Dial one number lower than the one originally used.
- At the starting line “1”, push the required number of needles to B position on both sides of centre(0).
- Pick up the stitches from the neck edge and place them onto the needles. (Illustration)
- With the Stitch Dial one number lower than the main tension, knit up to “2”.
- Turn up for neckband.
- Knit 1 row with the Stitch Dial 3-4 numbers higher and cast off.

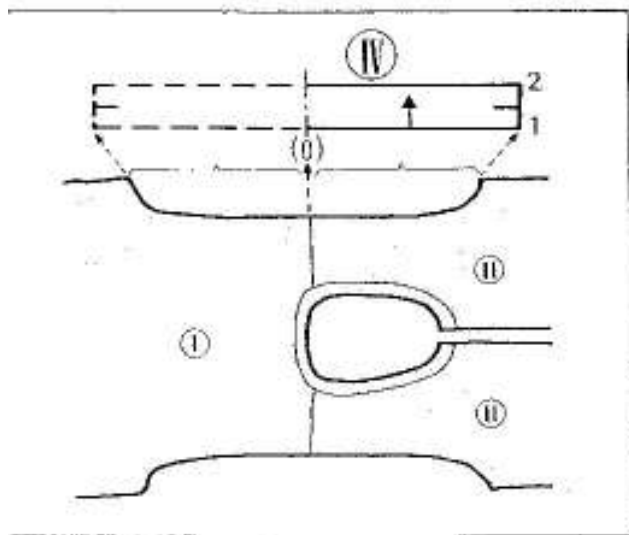

Armbands – pattern (IV)

- Set the Stitch Dial to the same number as used for the neckband.
- Knit two pieces with the same pattern.

Pick up the stitches from the armhole edge and knit in the same manner as done for the neckband. (Illustration)

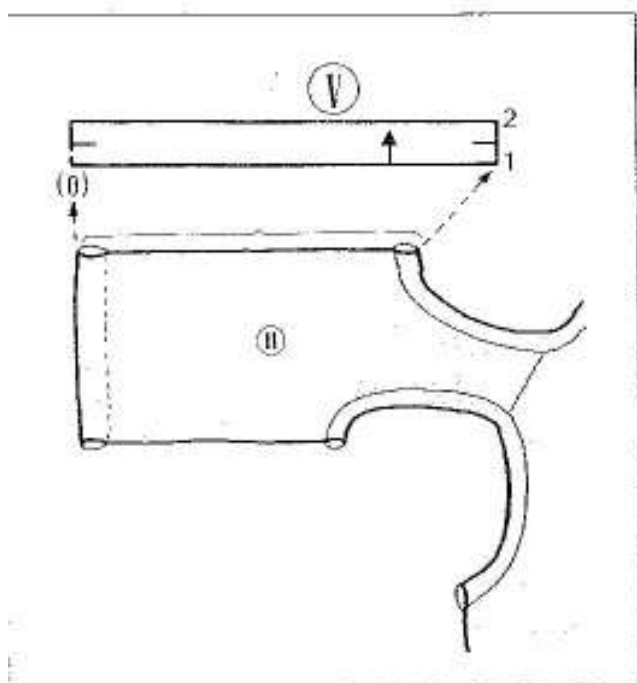

Borders – pattern (V)

Set the Stitch Dial to the same number as used for the neckband.

- At the starting line “1”, push up the required number of needles to B position on either side of centre(0).
- Pick up the stitches from the front centre edge and place them onto the needles. (Illustration)
- With the Stitch Dial one number lower than the main tension, knit up to “2”.
- Turn up for border and knit 1 row with the Stitch Dial 3-4 numbers higher to cast off.

Making up

- Join side seams.
- Knit two pieces of cord of about 30cm. long and sew on the neck.
- Make two pompons and attach to the cord.

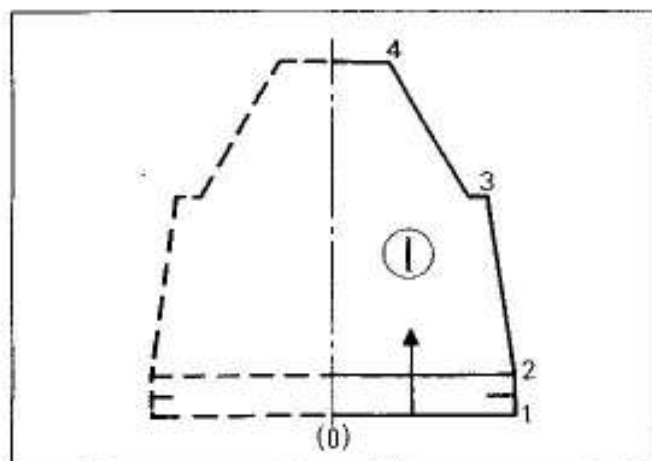
**Back** – pattern ①

- At the starting line "1", cast on stitches on both sides of centre(0).
- Knit up to "2", and turn up for hem.
- Knit up to "3", decreasing on both sides.
- Knit up to "4", decreasing on both sides.
- Cast off.

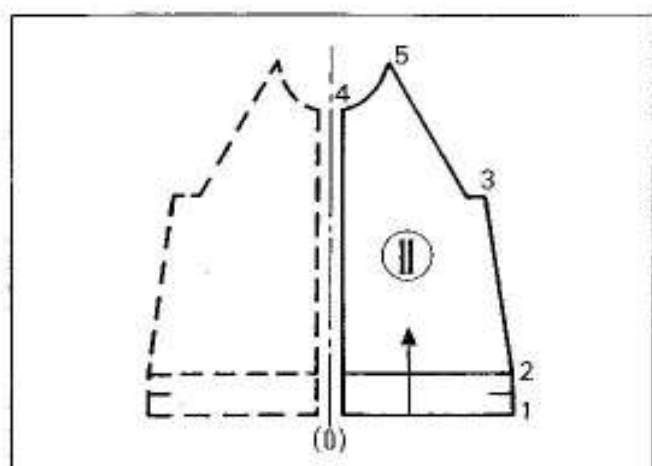
**Fronts** – pattern ②

Knit the right and left fronts in a symmetrical pattern.

- At the starting line "1", cast on stitches on either side of centre(0).
- Knit up to "2" and turn up for hem.
- Knit up to "3", decreasing on the side edge.
- Knit up to "4", decreasing at the raglan edge.
- Knit up to "5", decreasing at the neck edge and the raglan edge respectively.

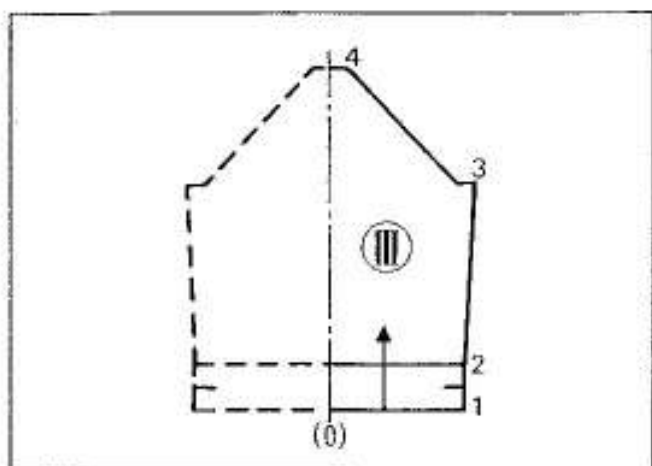
**Sleeves** – pattern ③

- At the starting line "1", cast on stitches on both sides of centre(0).
- Knit up to "2" and turn up for cuff.
- Knit up to "3", increasing on both sides.
- Knit up to "4", decreasing on both sides.
- Cast off.

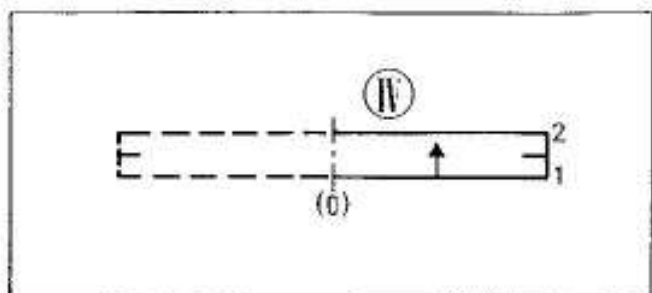
**Neckband** – pattern ④

Join all raglan seams before knitting the neckband.

- At the starting line "1", push the required number of needles to B position on both sides of centre(0).
- Pick up the stitches from the neck edge and place them onto the needles.
- With the Stitch Dial one number lower than the main tension, knit up to "2".
- Turn up for neckband, knit 1 row with the Stitch Dial 3–4 numbers higher and cast off.

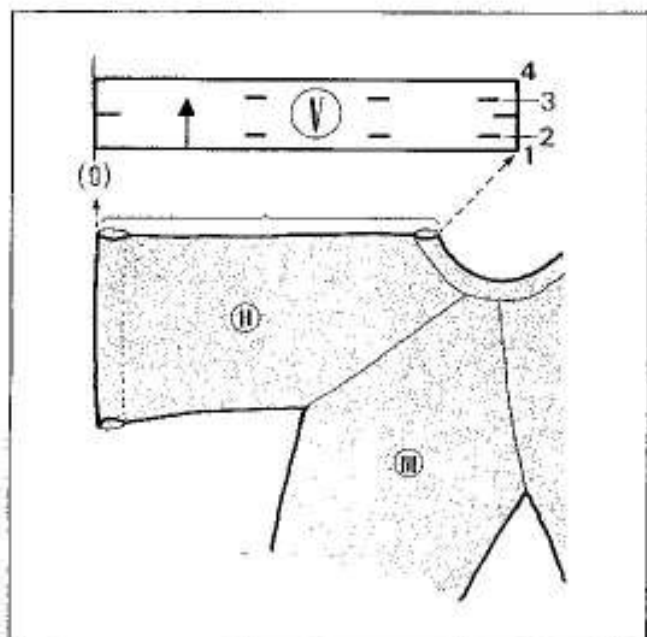

Borders – pattern (V)

Set the Stitch Dial to the same number as used for the neckband.

- At the starting line "1", push the required number of needles to 8 position on both sides of centre(0).
- Pick up the stitches from the centre front edge and place them onto the needles. (Illustration)
- Knit up to "4", making buttonholes at "2" and "3".
- Turn up for border, knit 1 row with the Stitch Dial 3–4 numbers higher and cast off.

Knit the other border in the same manner except for the buttonholes.

Making up

- Join the side and sleeve seams.
- Sew on buttons.

C – 8

CHILD'S BRIEF

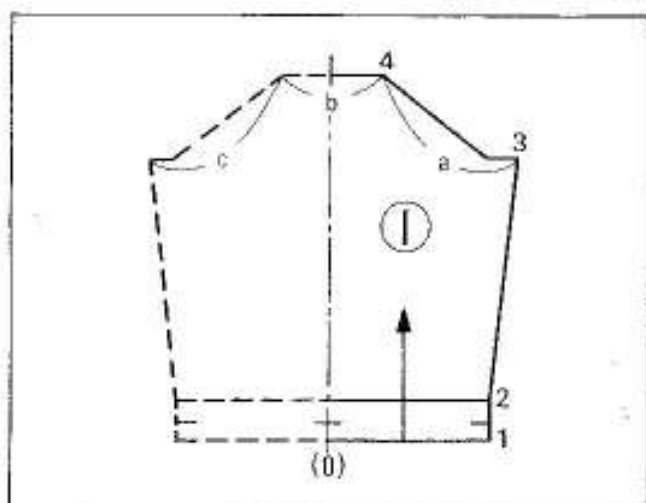

Front – pattern (I)

- At the starting line "1", cast on stitches on both sides of centre(0).
- Knit up to "2" and turn up for waistband.
- Knit up to "3", increasing on both sides.
- Work partial knitting on both sides up to "4".
- Push the needles for sections "a" and "c" to holding position.
- For section "b", remove on waste knitting.
- Push the needles for section "a" to knitting position and remove on waste knitting.
- Remove the remaining stitches on waste knitting.

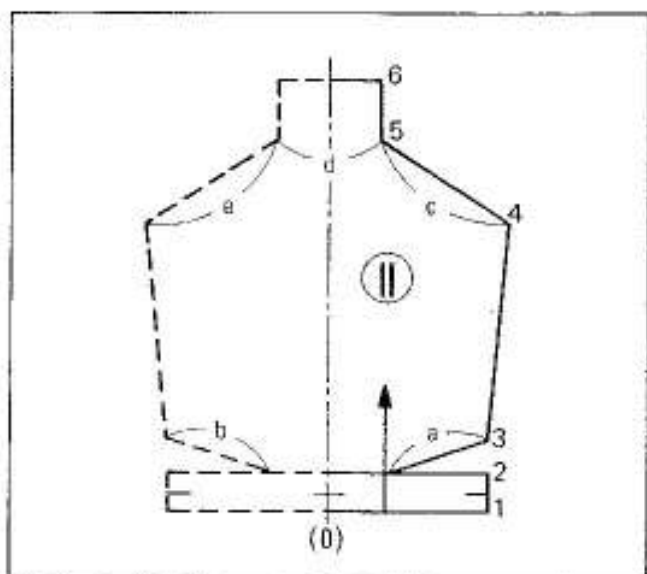

Back – pattern (II)

- Knit up to "2" in the same manner as done for the front.
- Knit 1 row and push the needles for sections "a" and "b" to holding position.
- Work partial knitting on both sides up to "3".
- Knit up to "4", increasing on both sides.
- Work partial knitting on both sides up to "5".
- Push the needles for sections "c" and "e" to holding position.
- For section "d", knit up to "6" and remove on waste knitting.
- Remove the stitches for sections "c" and "e" on waste knitting respectively.

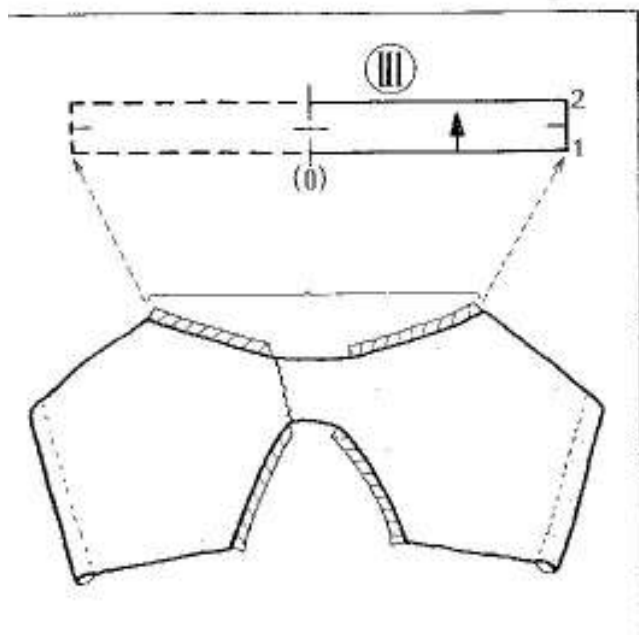

Legbands – pattern (III)

- Graft the front and back at the crotch before knitting the legband.
- Knit two pieces with the same pattern.
- At the starting line "1", cast on stitches on both sides of centre(0).
- Work mock rib or K1.P1. rib up to "2".
- Turn up for band in mock rib or transfer stitches onto knitter in K1.P1. rib.
- Pick up the stitches from the leg opening and place them onto the needles. (Illustration)
- Knit 1 row with the Stitch Dial 3–4 numbers higher and cast off.

Making up

- Join the side seams leaving an opening inside the waistband.
- Insert elastic through the waistband.

C – 9

LEGGINGS

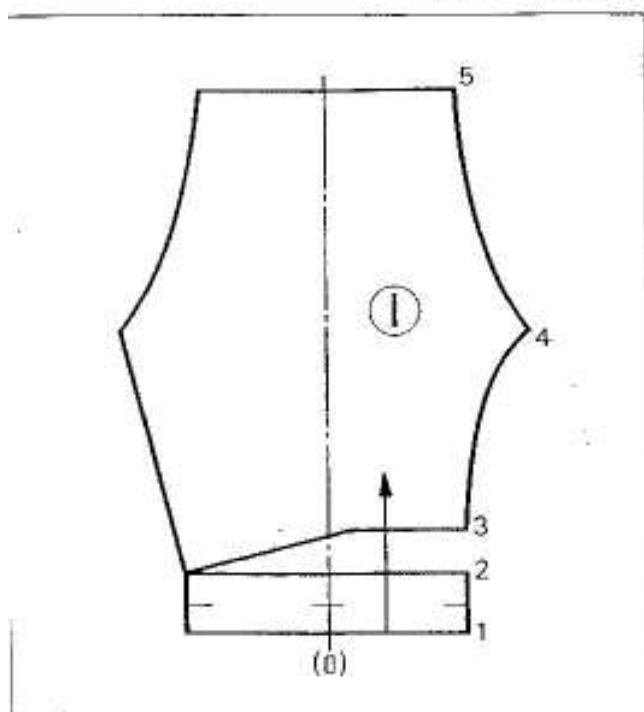

Leggings – pattern (I)

- Knit two pieces with the same pattern, but reverse shaping.
- Use the Centre Scale.
- At the starting line "1", cast on stitches required respectively on each side of centre(0).
- Knit up to "2" and turn up for waistband.
- Knit 1 row and push all the needles to holding position.
- Work partial knitting up to "3".
- Knit up to "4", increasing on both sides.
- Knit up to "5", decreasing on both sides.
- Remove the stitches on waste knitting.

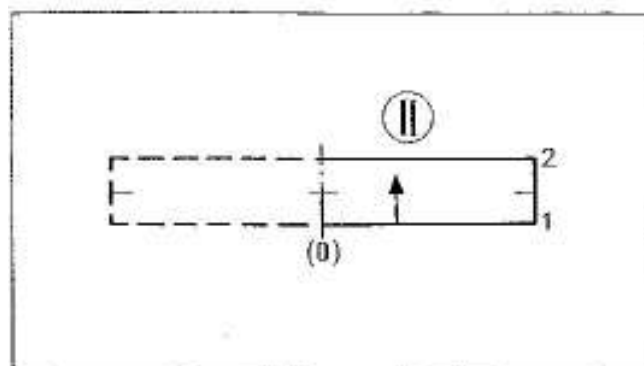

Anklebands – pattern (II)

Knit two pieces with the same pattern.

- At the starting line "1", cast on stitches on both sides of centre(0).
- Work mock rib or K1.P1. rib up to "2".
- Turn up for band in mock rib or transfer stitches onto knitter in K1.P1. rib, and knit 1 row.
- Replace the stitches of the ankle edge of the leggings.
- Knit 1 row with the Stitch Dial 3–4 numbers higher and cast off.

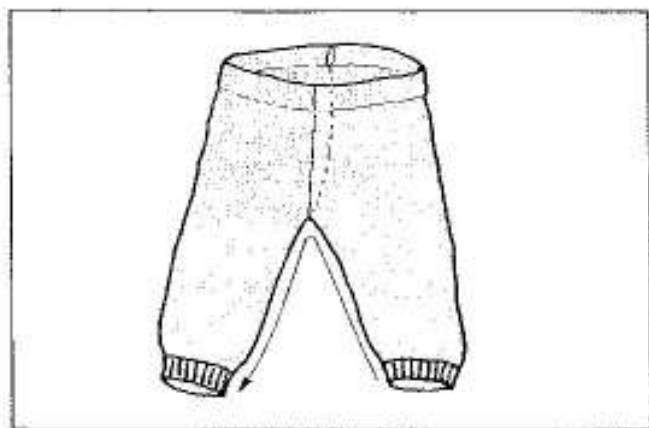

Making up

- Join the centre back and front seams leaving an opening inside the waistband.
- Join the inside leg seams continuously. (Illustration)
- Insert elastic through the waistband.

C - 10

ROMPERS

Front - pattern (I)

- At the starting line "1", cast on stitches on both sides of centre(0).
- Knit up to "2" and purl the stitches on the row.
- Knit up to "3" and turn up for waistband.
- Knit up to "4", increasing on both sides.
- Work partial knitting on both sides up to "5".
- Push the needles for sections "b" and "c" to holding position.
- For section "a", push the needles to knitting position and remove on waste knitting.
- Remove the stitches for section "c" on waste knitting.
- Push the needles for section "b" to knitting position and knit straight up to "6".
- Put yarn mark through the row.
- Knit in stockinet up to "7" and cast off.

Back - pattern (II)

- Knit up to "3" in the same manner as done for the front.
- Knit 1 row and push the needles for section "a" and "b" to holding position.
- Work partial knitting up to "4".
- Knit up to "5", increasing on both sides.
- Work partial knitting on both sides up to "6".
- In the same manner as done for the front, remove the stitches for section "c" and "a" on waste knitting.
- For section "d", knit up to "7".
- Knit in stockinet up to "8".
- Put yarn mark through the row.
- Return the Pattern Paper to "7" and knit up to "8" once more.
- Cast off.

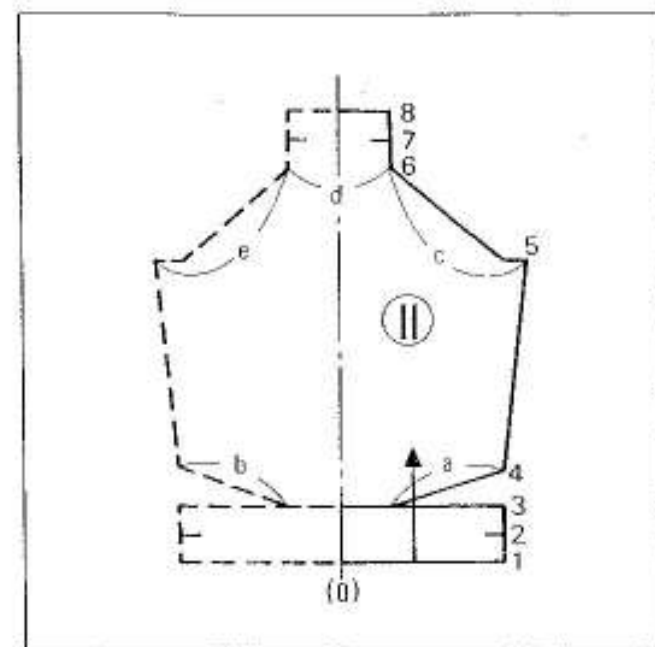
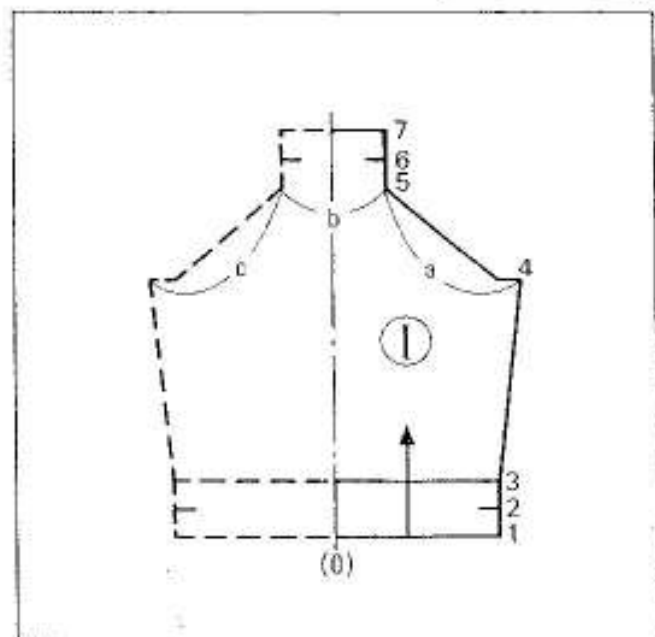

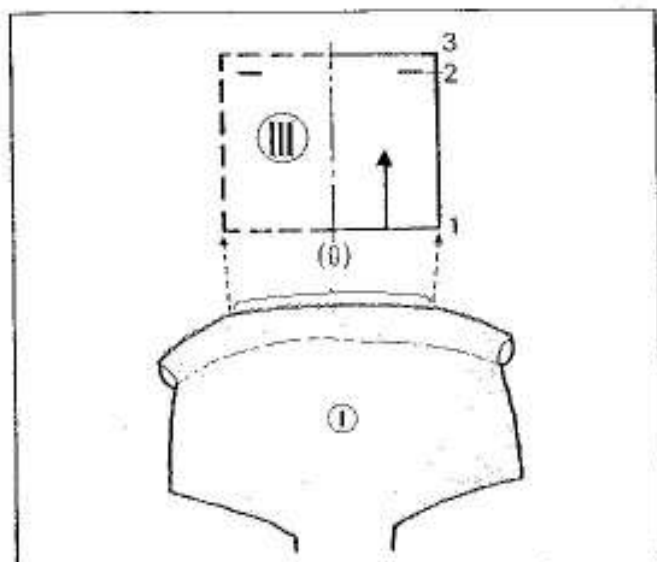

Bib – pattern (III)

- At the starting line "1", push the needles to B position on both sides of centre(0).
- Pick up the same number of perl stitches from the centre of front waistband and place them onto the needles.
- Knit straight up to "2".
- Make buttonholes.
- Knit up to "3" and cast off.

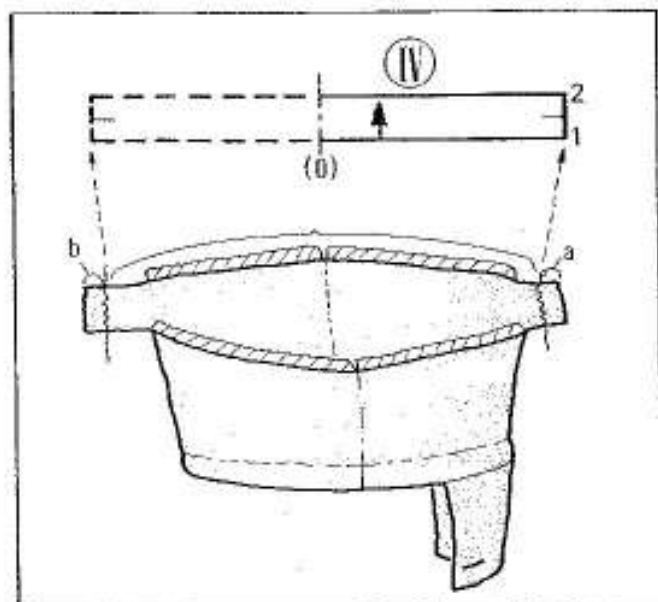

Legbands – pattern (IV)

- Before knitting the legband, join the side seams.
- Knit two pieces with the same pattern.
- At the starting line "1", cast on stitches on both sides of centre(0).
- Work mock rib of K1.P1. rib up to "2".
- Transfer stitches onto knitter in K1.P1. rib, then turn up for band and knit 1 row.
- Pick up the stitches from the leg opening edge except for sections "a" and "b" and place them onto the needles. (Illustration)
- Knit 1 row with the Stitch Dial 3–4 numbers higher and cast off.

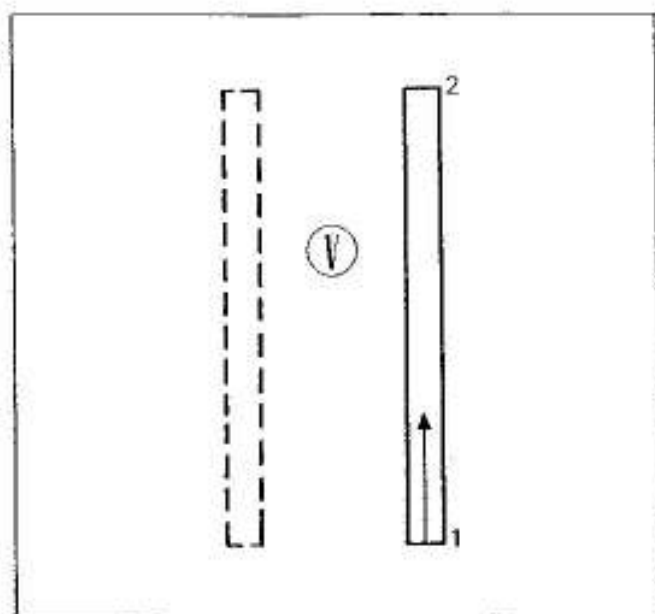

Shoulder straps – pattern (V)

Knit two pieces with the same pattern.

- At the starting line "1", cast on for twice the number of stitches as read on the Stitch Scale.
- Knit in K1.P1. rib up to "2".
- Transfer stitches onto knitter and cast off.

Making up

- Stitch down the facings on the crutch.
- If the legbands are knitted in K1.P1. rib, fold them in half and stitch down.
- Trim the edge of the bib in crochet stitch.
- Sew the shoulder straps on and also the buttons.

INDEX

A

ankleband	65
armband	62
armhole	16, 20
Arrow mark	7
Automatic Linker	20
Auxiliary Feeding Cam	4, 10, 21

B

back	15, 53, 56, 64
Back legs	55
Back width	8
Bib	67
blind stitch	37
blocking	19
border	35, 52, 58
brief	64
Bust	8
buttocks	8
buttonhole	36, 51

C

cable stitch	39
Cam Lever	21
cardbord	40
cardigan	52, 57
cast off	32, 33
cast on	13
Centre Line	7, 11, 12
Centre Scale	11
centre straight section	18
Change Dial	9, 10, 21
Claw Weight	3, 23, 30
Clip	9
coat	63
Comb Weight	3
cord knitting	40
Crochet Hook	37
cuff	15

D

decrease	14, 24, 43
double border	36
double jacquard	49
drive lace knitting	48

E

Edge Weight	41
-------------------	----

F

Feeding Dial	9, 10, 21
--------------------	-----------

Feed Lever	9, 12
front	17, 52, 53, 56, 64
front legs	55

G

Garter Bar	39
garter stitch	39
Gauge Scale	6
grafting	37

H

Half-Pitch Lever	43
hemming	34
Hip	8
holding stitches	30, 31
Horizontal Standard Line	7, 12

I

increase	14, 22, 41
Inspection Button	21

J

Joining	37
---------------	----

K

Knit Contour	9, 13, 15, 21
K1, P1, Rib	16, 38

L

Lace Carriage	21, 23, 27, 31
lace knitting	21
lace stitch pattern	3
legband	65, 67
Leggings	65
Length	8

M

Main Carriage	26, 28, 30, 31
Measurement Table	7, 8
mock rib	15, 33

N

neckband	15, 20, 35, 60
neck edge	18, 20
neckline	16, 17, 18
neck point	16, 18

O

on-piece dress 56

P

Page number 7
 Paper Holder 9
 Paper Lever 9
 Paper Slit 9
 partial knitting 14, 26, 45
 Pattern Card 1, 15, 21
 pattern knitting 21, 26, 28
 pattern paper 7, 10
 Pattern piece number 7
 Pattern size 7, 8
 Pattern style 7
 Pattern style number 7
 Pattern Width Indicator 1
 P Carriage 48
 picot eyelets 34
 pile knitting 48
 pocket 58
 pocket band 58
 Point Cam 22
 Pompon 40
 pressing 19
 pullover 15, 53, 59

R

raglan sleeve 53, 60
 Ravel Cord 30, 38
 Release Lever 21
 Ribber 4, 16, 41
 rompers 66
 Row Counter 21
 row number 9
 Row Number Dial 9
 Row Number Window 9
 Russel Lever 26, 30, 45

S

Shaping sequence number 7
 shoulder 16, 20
 shoulder point 8, 16, 18
 shoulder strap 67
 Side Hanger 41
 side seams 37
 sinker loops 33
 sinker post 45
 skirt 54, 61

slacks 55
 sleeve 19, 54
 Sleeve length 8
 sleeve seams 20
 slip stitch 20, 37
 Stitch Scale 11
 stockinet knitting 21, 26, 28
 swing 47

T

Tapestry Needle 37, 40
 Tappet Tool 32
 Tension Gauge 1, 13
 Tension Swatch 1, 6
 thick yarn 3, 10
 Top 61
 Transfer Tool 33
 trimming 35

V

vertebra 8
 vertical expansion 21
 Vertical Standard Line 7, 12

W

Weist 8
 waste knitting 31, 50
 welt 15
 wrist 8

Y

yarn mark 3, 19