

KNITTING MANUAL

MOD. 700/600

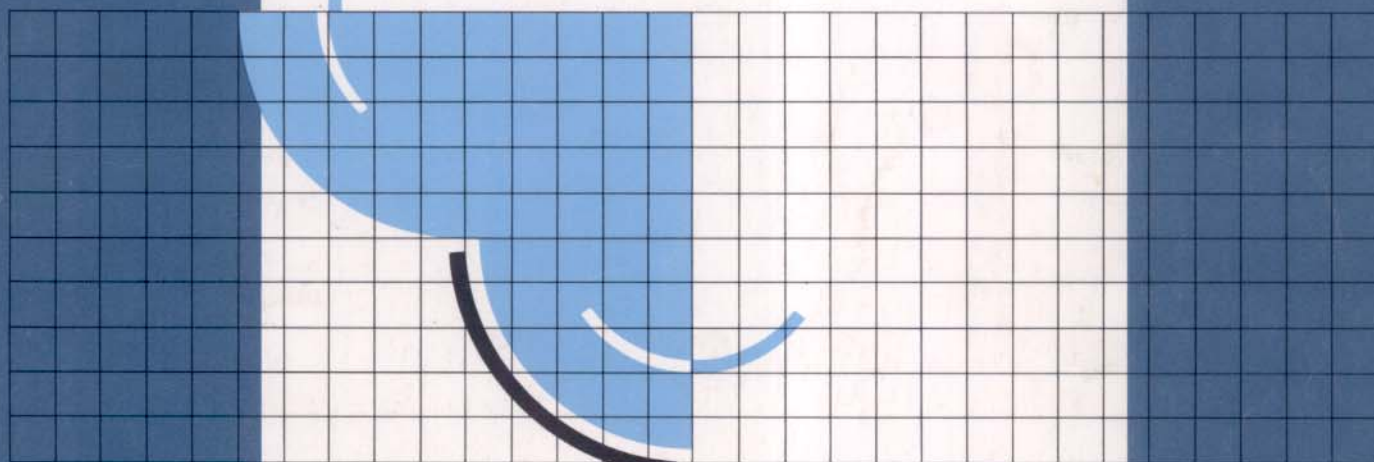

Empisal-KNITMASTER

CONTENTS

	page
TAKING A TENSION GAUGE	1
KNITTING TECHNIQUES	4
Fully fashioned decrease	4
Fully fashioned increase	4
Partial knitting	5
Decreasing stitches only for Main Carriage	5
Decreasing stitches for Lace Carriage	6
Increasing stitches only for Main Carriage	7
Increasing stitches for Lace Carriage	8
K1.P1. Rib	9
Mock Rib	11
Cast-on by winding yarn	12
Picot hem	13
Holding stitches	14
Put the yarn mark	16
Cast off with back stitch method	16
Cast off with Tappet Tool	18
Trimming	19
Buttonhole by transferring stitches	20
Buttonhole by hand work	21
Joining on the machine	21
Blind stitch	23
Grafting	23
Slip stitch	24
Sew in yarn ends	24
Cord knitting	25
Cable pattern	25
Garter stitch	26
Blacking and pressing	26
IF MISTAKES OCCUR DURING KNITTING	27
KNITTING WITHOUT USING THE KNIT CONTOUR	28
SELECTING A PATTERN	35
SETTING UP THE KNIT CONTOUR	37
KNITTING USING THE KNIT CONTOUR (RADAR)	42
A — 1 Lady's Pullover	43
A — 2 Lady's Raglan Sleeve Pullover	47
A — 3 Lady's Cardigan	47
A — 4 Lady's French Sleeve Pullover	47
A — 5 Lady's Skirt	48
A — 6 Lady's Slacks	48
B — 1 Man's Pullover	42
B — 2 Man's Raglan Sleeve Pullover	47
B — 3 Man's Saddle Shoulder Cardigan	49
B — 4 Man's Vest	49
C — 1 Girl's Cardigan	50
C — 2 Boy's Raglan Sleeve Cardigan	50
C — 3 Child's Cardigan	50
C — 4 Child's Dress	50
C — 5 Baby's Coat	51
C — 6 Baby's Leggings	52
C — 7 Baby's Pants	52
TO KNIT WITH FULL SIZE PATTERN	53
IF INCORRECTLY KNITTED	54

TAKING A TENSION GAUGE

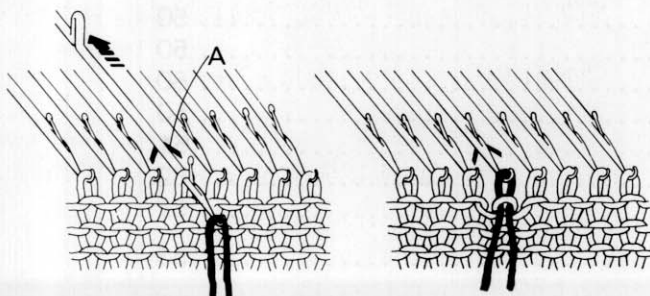
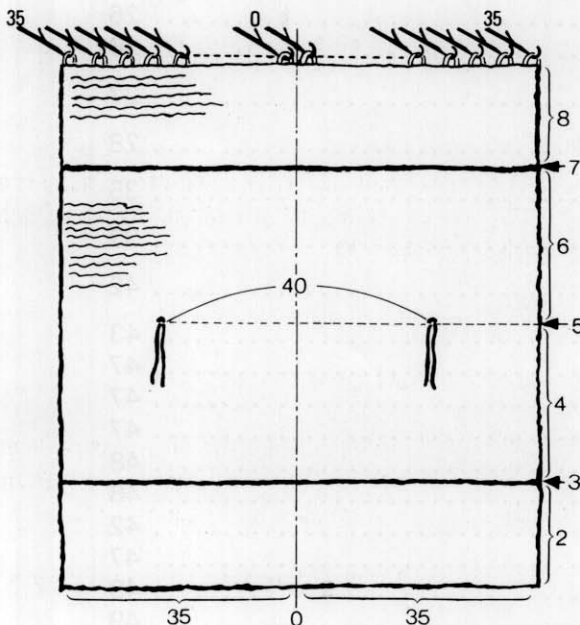
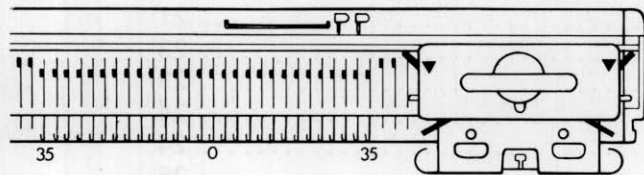
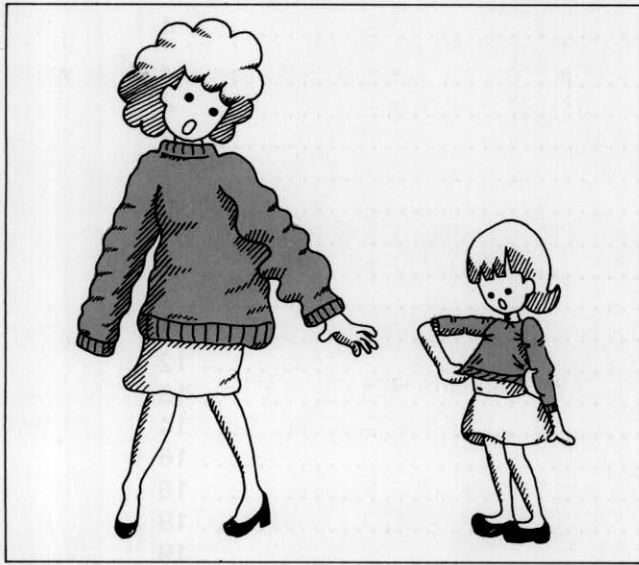

Tension Gauge

Tension Gauge indicates how many stitches and rows per 10cm.

It is very important to take a correct tension gauge to knit a desired garment in the size you selected.

To take a correct tension gauge, the tension swatch must be knitted in the same stitch type, with the same yarn and Stitch Dial as to be used for the garment.

To knit a Tension swatch:—

Prepare the yarn you selected and a small amount of different colour yarn for marking on the swatch.

Determine the Stitch Dial referring to page 9 on the Operation Manual, but it is recommended to try knitting by changing stitch dial settings till you obtain a suitable stitch dial number for the yarn and stitch type.

Knit the swatch in the manner as instructed below.

1. Arrange 35 needles on both sides of the centre(0), 70 needles in total for cast-on.
2. Cast-on with main yarn and knit 10 rows continuously in selected stitch type with suitable Stitch Dial.
3. Exchange the main yarn in the Yarn Feeder for the contrast yarn, and knit two rows in stockinet.
4. Cut the contrast yarn and rethread the main yarn, and knit 30 rows in selected stitch type with suitable Stitch Dial.
5. Push both 21st needles (A mark "A" on the Needle Bed) from the centre(0) to D position and place a piece of contrast yarn in each of those needle hooks.
Push those needles back to B position by hand.
6. Knit another 30 rows.
7. Thread the contrast yarn and knit 2 rows in Stockinet.
8. With main yarn, knit 10 rows in selected stitch type with suitable Stitch Dial.

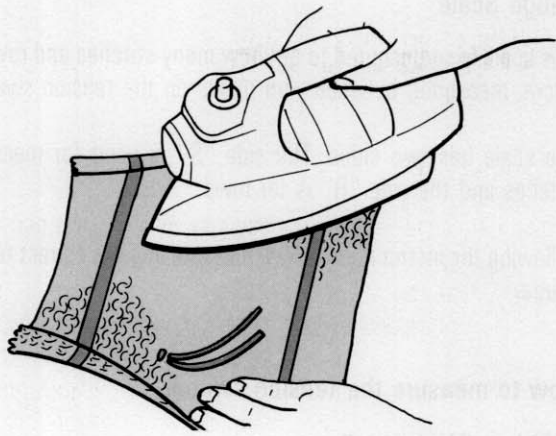

Remove the yarn from the Yarn Feeder and remove the swatch from the machine by moving the Carriage once.

TAKE NOTE OF THE STITCH DIAL NUMBER

Allow several hours for the swatch to return to its natural condition. Press the swatch lightly with a steam iron, or with an ordinary iron over a damp cloth.

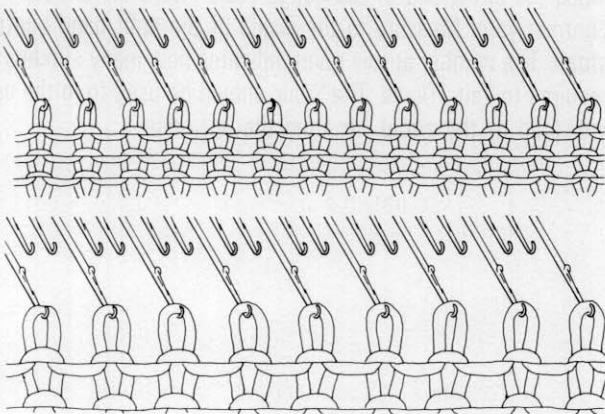

When you knit with very thick yarn...

Every other or every third needle selection is required for very thick yarn.

Take care to select Punch Card for pattern knitting.

Knit the tension swatch (e.g. every other needle selection) in the manner instructed below.

1. Push 35 needles on both sides of the centre(0) to B position, and push every other needles back to A position using the 1/1 Needle Pusher, so as the needles are arranged as shown below.

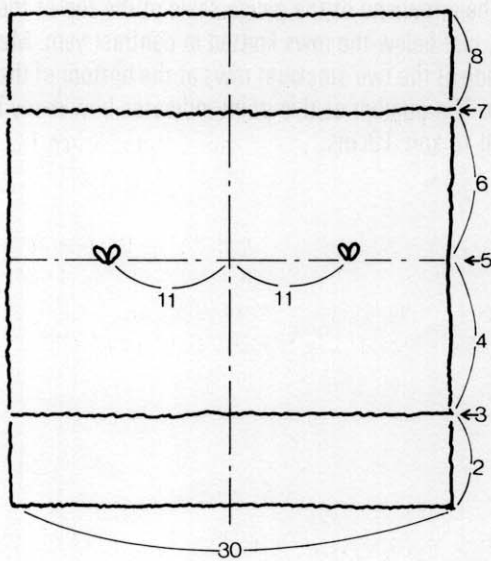
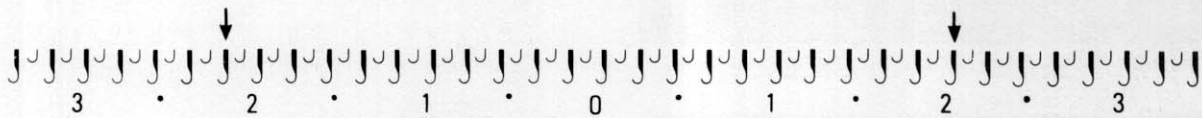

2. With the main yarn, cast-on and knit continuously checking tension on the fabric, till you obtain suitable Stitch Dial number. Knit 10 rows.
3. With a contrast yarn, knit two rows stockinet.
4. With the main yarn, knit 15 rows.
5. Push the 11th needle on both sides of the centre(0), marked by arrows as shown above, lay a contrast yarn in the needle hooks, and push them back to B position.
6. Knit another 15 rows continuously with the main yarn.
7. With the contrast yarn, knit 2 rows stockinet.
8. With the main yarn, knit another 10 rows.

Take note of the Stitch Dial number

Remove the swatch from the machine.

As the fabric is extended sideways, pull it vertically.

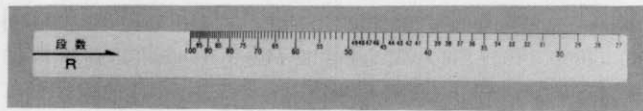
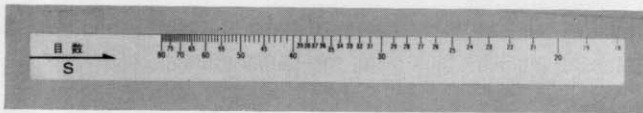

Gauge Scale

This scale is so designed to get how many stitches and rows per 10cm. measuring between yarn marks on the tension swatch.

The scale has two sides. The side "S" is used for measuring stitches and the side "R" is for rows.

Following the instructions below, measure and get correct tension gauge.

How to measure the tension swatch

Stitches (Horizontal)

Use the Gauge Scale (Green) With the "S" side up. Place the arrow end of the gauge scale inside the left stitch in contrast yarn. Measure to the inside of the right hand contrast stitch. The number at this point indicates how many stitches are required to knit 10cms. The Scale should be used from the edge indicated by the arrow, i.e. from the left edge.

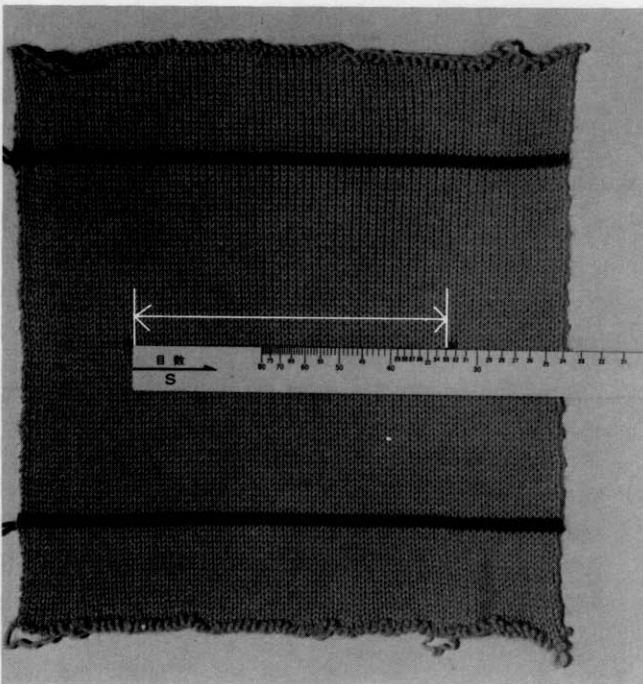

Row (Vertical)

Use the Gauge Scale (Green) With the "R" side up. Place the arrow end of the gauge scale at the top of the tension square, just below the rows knitted in contrast yarn. Measure to the inside of the two stockinet rows at the bottom of the tension swatch. The number at this point indicates how many rows are required to knit 10cms.

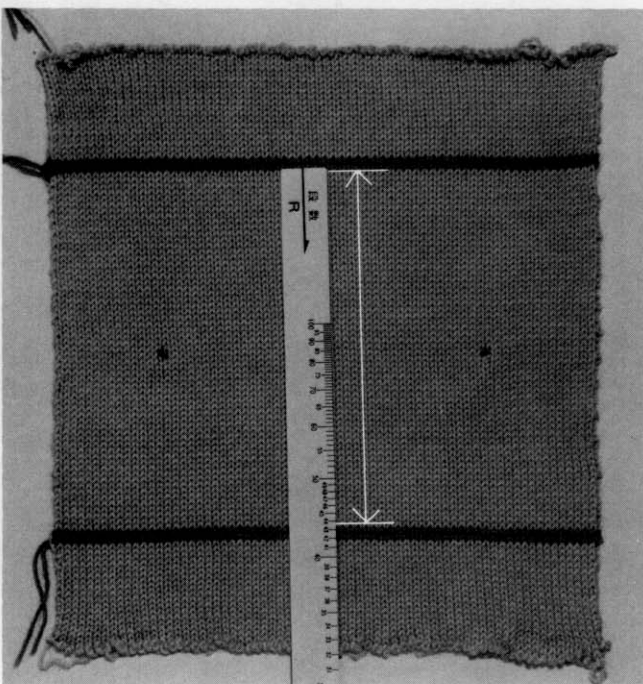

KNITTING TECHNIQUES

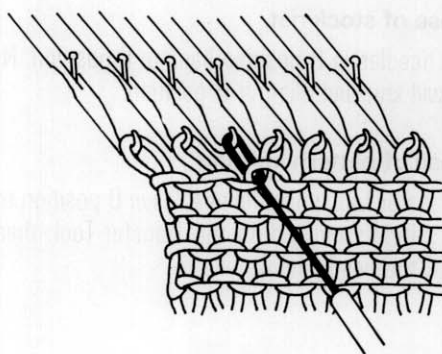
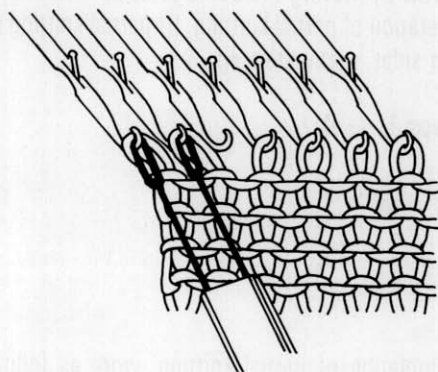
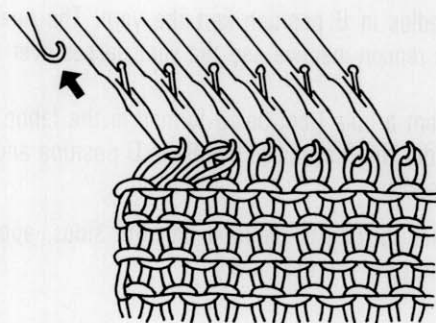
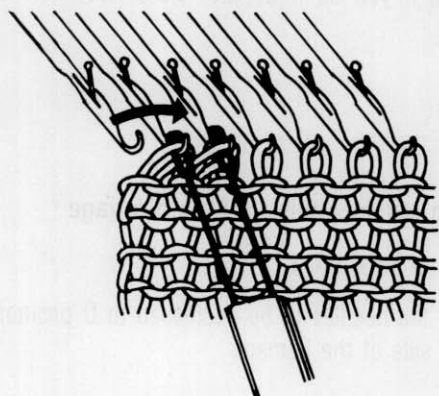

Fully fashioned decrease

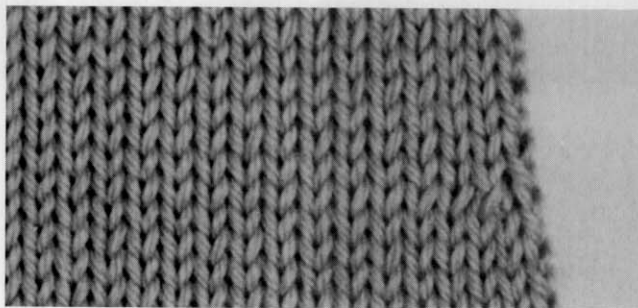

Possible to decrease 1 stitch on both sides at the same time.

1. With a two prong Transfer Tool, transfer the two end stitches onto one needle inside.
In case of every needle selection, use a three prong Transfer Tool.
2. Push the end empty needle back to A position.
Continue to knit.

Fully fashioned increase

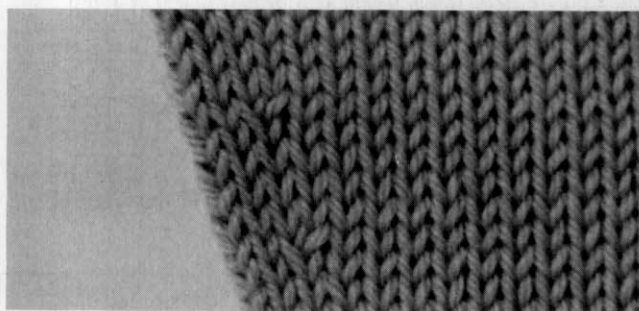

Possible to increase 1 stitch on both sides at the same time.

1. Push the empty needle, adjust to the end stitch, to B position.
With a two prong Transfer Tool, transfer the two end stitches one needle out.
In case of every other needle selection, use a three prong Transfer Tool.
2. Pick up the loop below the third stitch and place it onto the empty needle as shown.
Continue to knit.

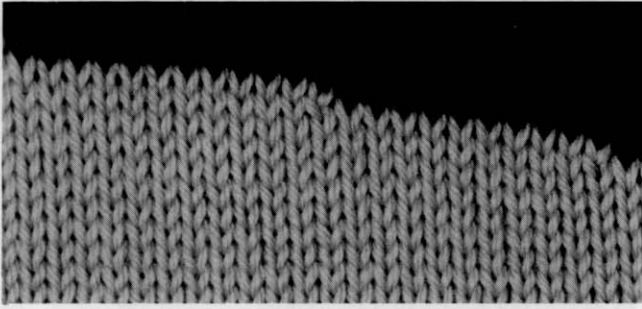

PARTIAL KNITTING is a practical method for shaping a gentle slope, such as a shoulder, but darts and so on.

You can do partial knitting only on the opposite side of the Carriage, so if you do it at both sides, work left and right alternately.

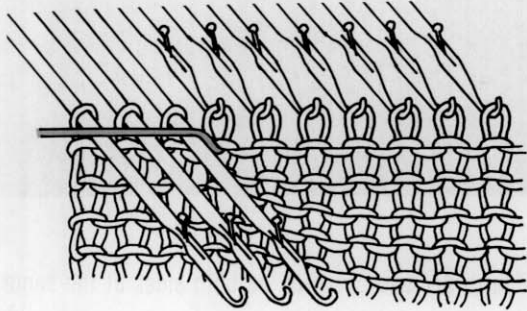

Decreasing stitches only for Main Carriage

Set the Russel Levers to **I**.

1. Push up the needles to be decreased to D position on the opposite side of the Carriage.

2. Knit 1 row.

The needles in B position knit the yarn. The needles in D position remain inactive and the yarn passes over them.

3. To prevent a hole from being formed in the fabric, pass the yarn under the first inside needle in D position and over the other needles.

(If partial knitting is required on both sides, apply step 1 before knitting the next row.)

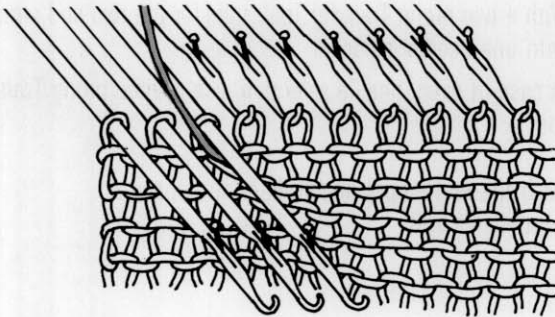

4. Knit 1 row by moving the Carriage back. This completes the first operation of partial knitting. (If partial knitting is required on both sides, apply step 3.)

Repeat steps 1 — 4.

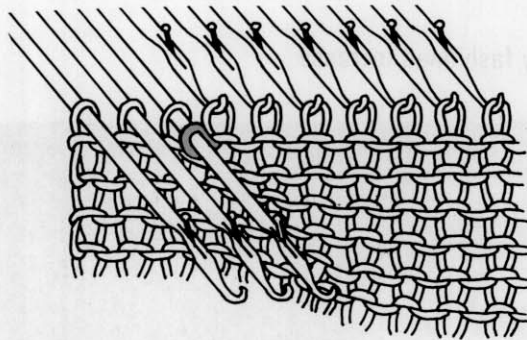

At the completion of partial knitting, work as follows to knit continuously.

A. In case of stockinet

Push the needles in D position back to C position. Needles in C position will knit and align in B position.

B. In case of pattern knitting

With a Transfer Tool, push the needles in D position to A position until the stitches move onto the Transfer Tool, then place the stitches in the needle hooks.

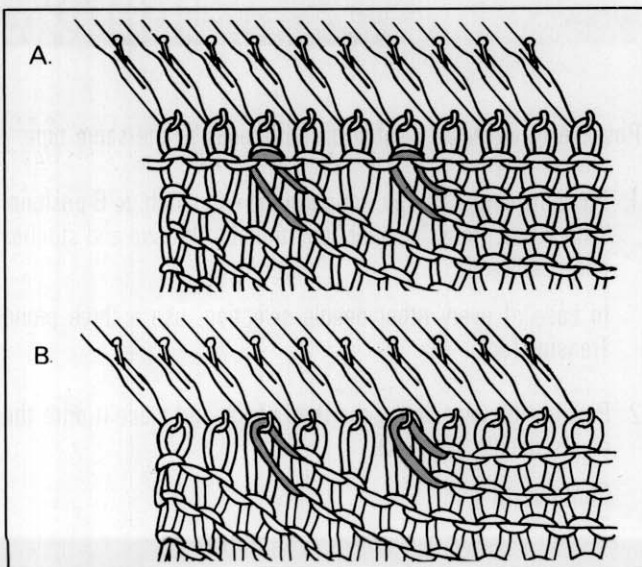

Decreasing stitches for Lace Carriage

1. Push the needles to be decreased to D position on the opposite side of the Carriage.
2. Lay the Ravel Cord into the open needle hooks, and knit the needles back one by one from D to A position by hand.
3. Replace the edge pin at the two end needles in B position.

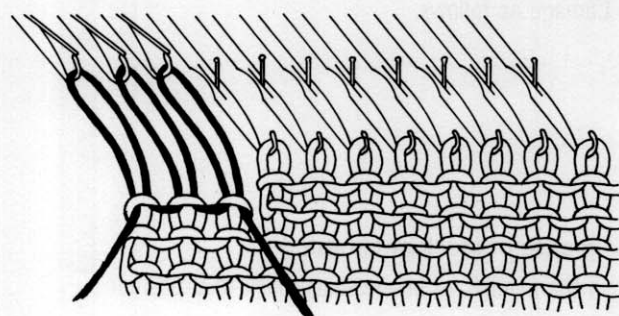
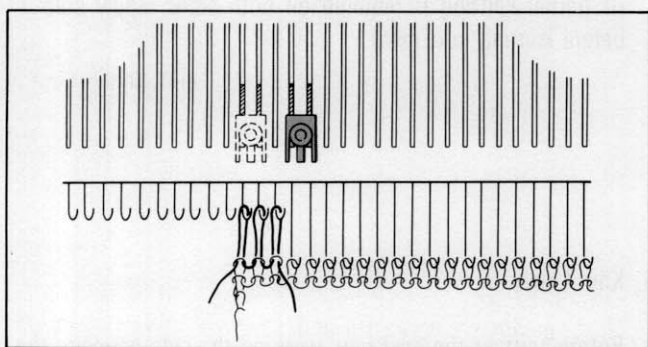
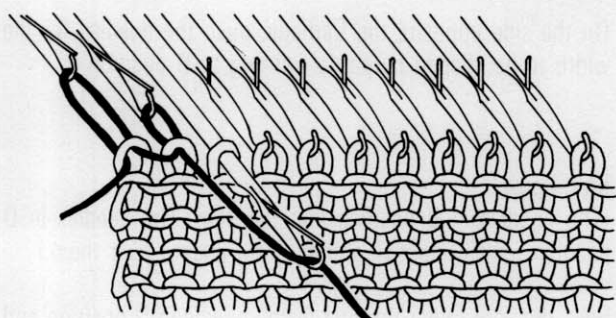
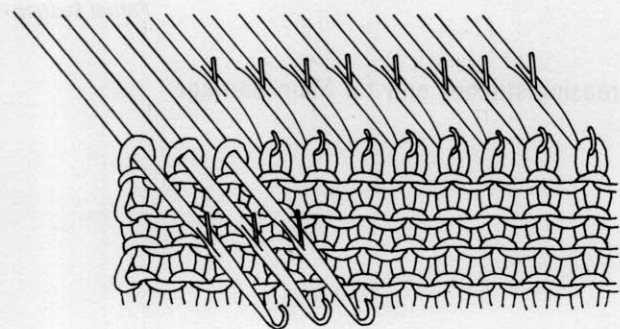

4. Knit two rows.
5. Repeat steps 1 through 4 for required rows.

If partial knitting is required at both sides apply steps 1 to 3 and 4* knit 1 row.
Repeat steps 1 to 4* for required rows.

When the partial knitting is completed, hang the weights and replace the stitches into needle hooks by pulling up the Ravel Cord.

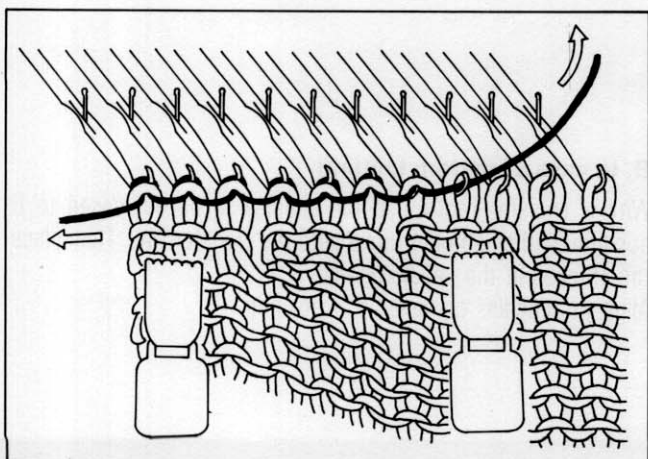

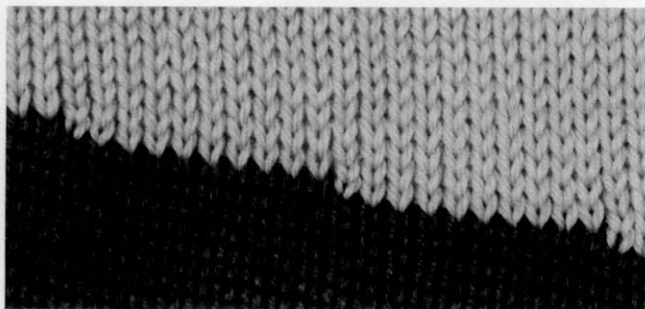

Increasing stitches only for Main Carriage

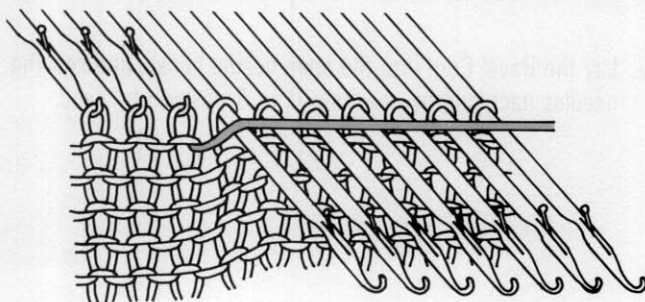

Set the Russel Levers to **I**.

1. On the side opposite the Carriage, push the needles for the width to be shaped by partial knitting to D position.
2. Knit 1 row.
(The needles in B position knit the yarn. The needles in D position remain inactive and the yarn passes over them.)
3. Pass the yarn under the first inside needle in D position and over the other needles.
(If partial knitting is required on both sides, apply step 1 before knitting next row.)

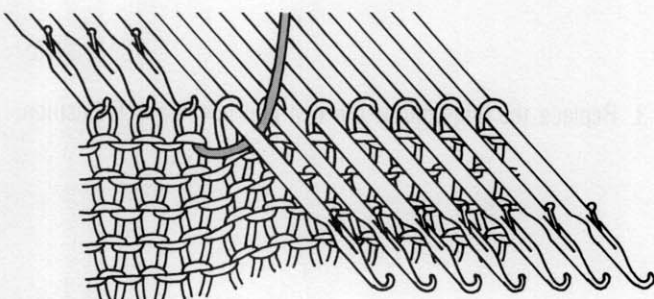

4. Knit 1 row.
5. Before knitting the next row, work on the side opposite the Carriage as follows.

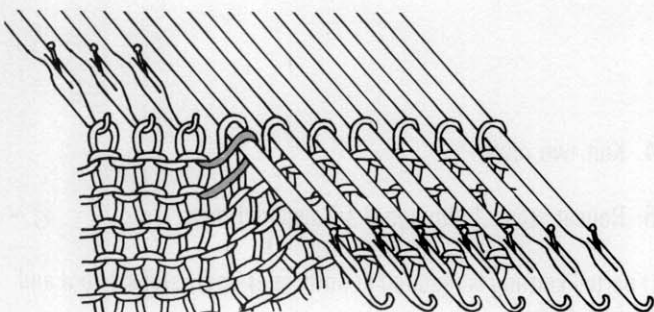

A. In case of stockinet knitting

Push the needles to be increased back to C position.

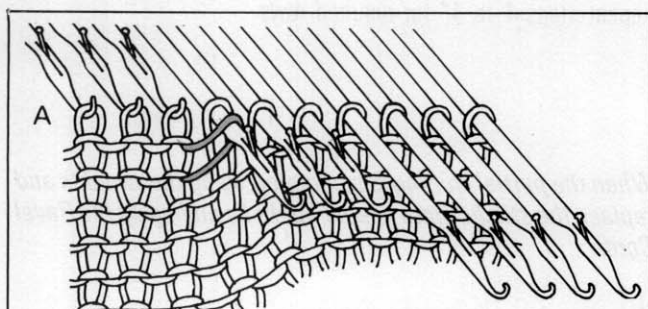

B. In case of pattern knitting

With a Transfer Tool, push the needles to be decreased to B position till their stitches move onto the Transfer Tool. Then place the stitches in the needle hooks. Align the needles correctly in B position.

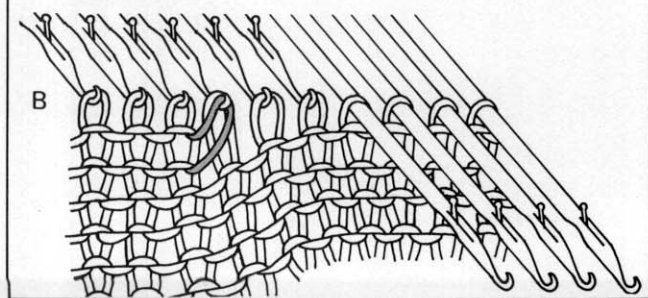

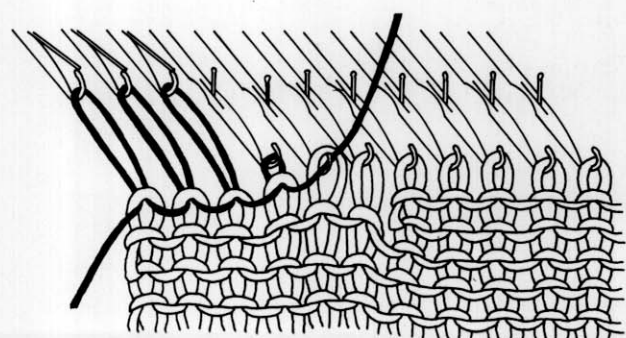
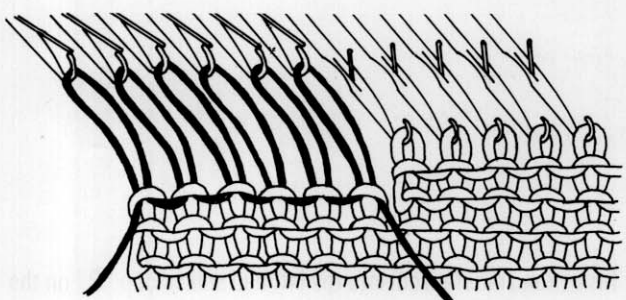
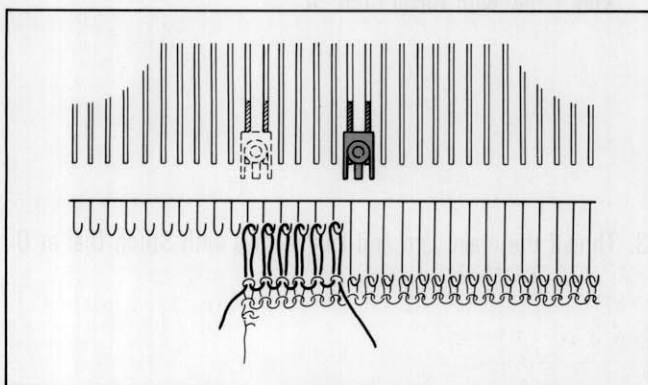
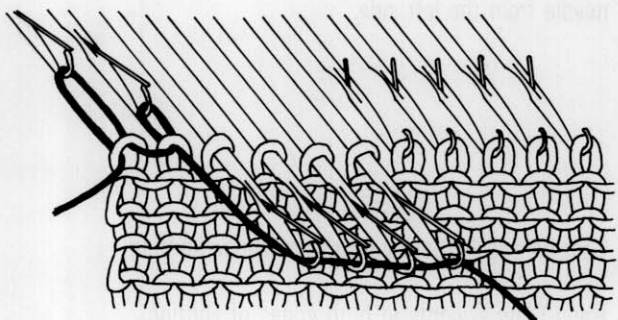
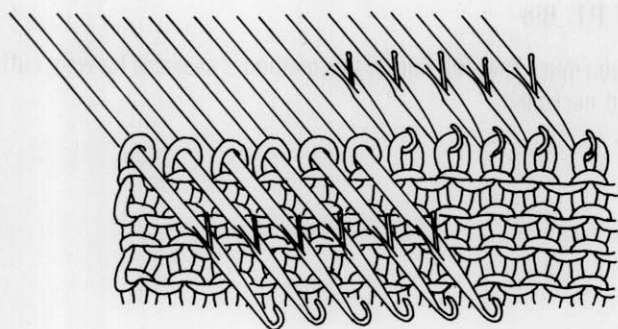

Increasing stitches for Lace Carriage

1. On the side opposite the Carriage, push the needles for the width to be shaped by partial knitting to D position.
2. Lay the Ravel Cord into the open needle hooks and knit the needles back one by one from D to A position by hand.
3. Replace the Edge Pin at the end two needles in B position.

4. Knit two rows.

If partial knitting is required on both sides apply steps 1 ~ 3, but at step 4 knit 1 row.

5. On the side without yarn end, push up the needles required for increase to B position, and unravel the Ravel Cord to replace the stitches into the needle hooks.
 6. Replace the Edge Pin at the end two needles in B position.
- Repeat steps 4 ~ 5 for required rows.

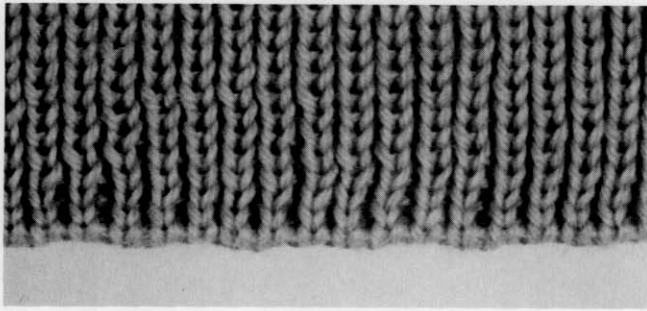

K1.P1. Rib

If you don't have Rib Knitter this method is available for welt, cuff and neckband.

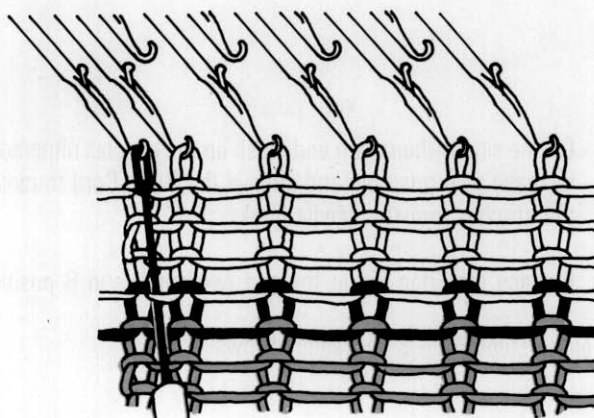
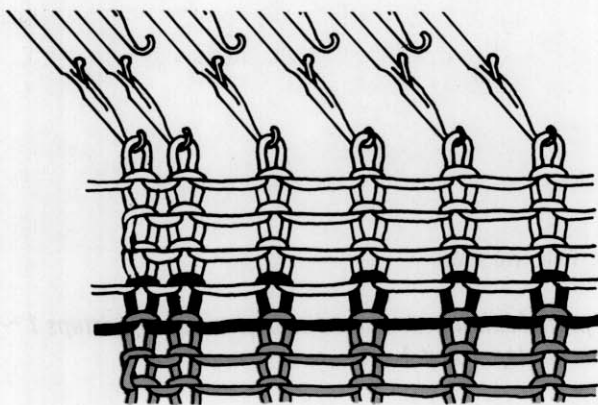
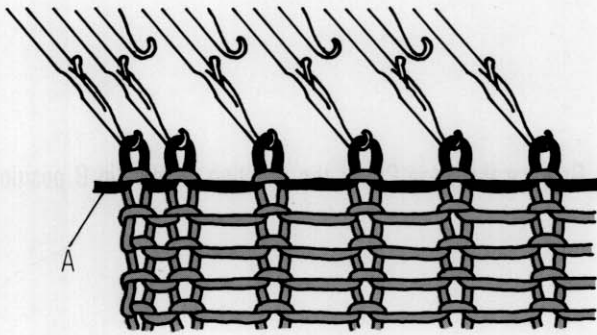
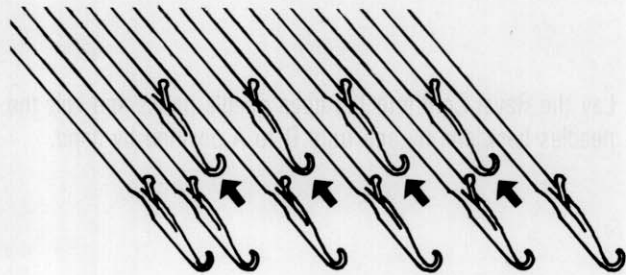

1. Push the required number of needles to B position and push back every other needle to A position starting from the third needle from the left side.

2. Cast-on and knit several rows of waste knitting.

Hang Claw Weights at both edges of knitting.

Knit 1 row with Ravel Cord "A".

3. Thread the main yarn and knit 4 rows with Stitch Dial at 0.

4. Insert the Transfer Tool into the left end sinker loop "B" on the first row of the main knitting.

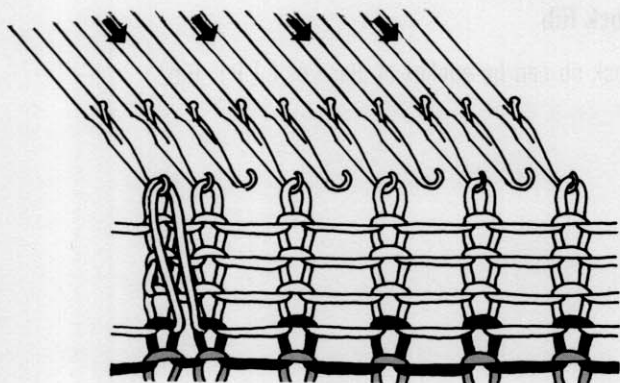

5. Place the loop onto the end needle. Push those needles that were pushed back to A position in step 1, to B position.

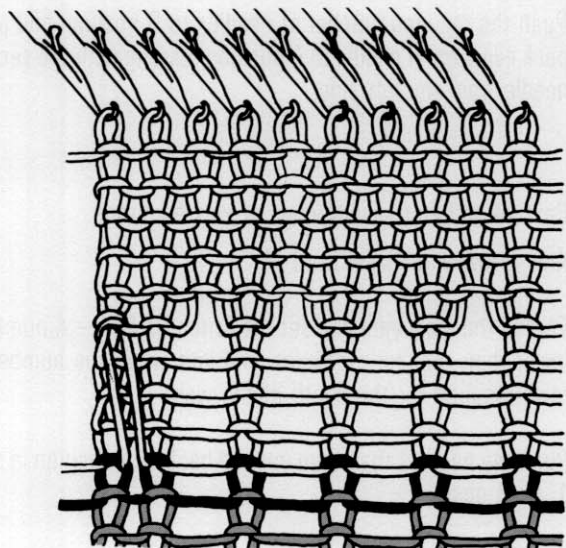

6. Knit the length required for ribbing with the Stitch Dial 2 numbers lower than that for Stockinet knitting.

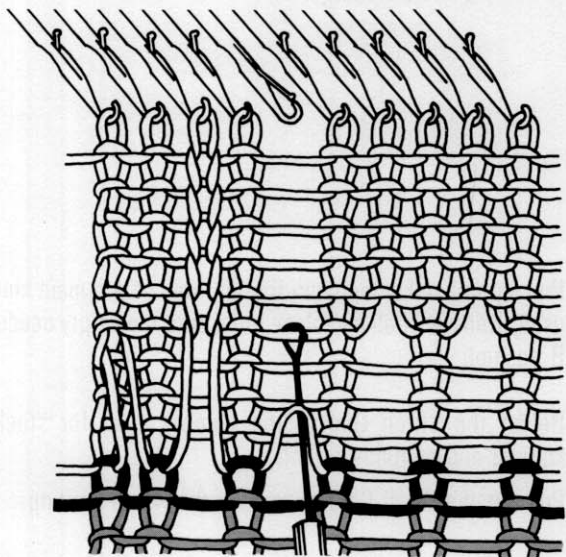

7. Insert the Tappet Tool into the loop of the first row of main knitting and unravel the stitches as shown. Skip over the next 3 rows and catch the yarn on 5th row crossing above, into the hook of the Tappet Tool.

8. Pull the Tappet Tool towards you. The first stitch will slip off of the Tappet Tool, forming a new stitch.

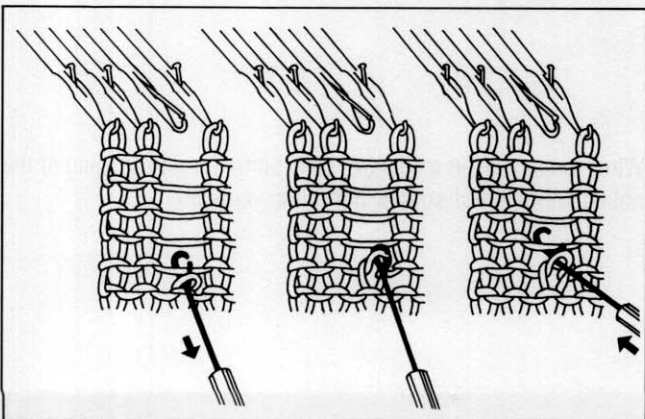

9. Catch the yarn on the next row crossing above and pull the Tappet Tool towards you.

10. Repeat step 9 for every row. Place the last stitch back onto its needle.

Reform every other stitch in the same manner as above.

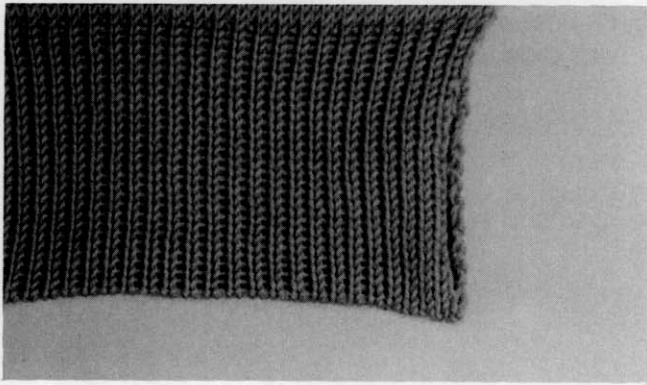

Mock Rib

Mock rib can be applied in place of K1.P1. Rib.

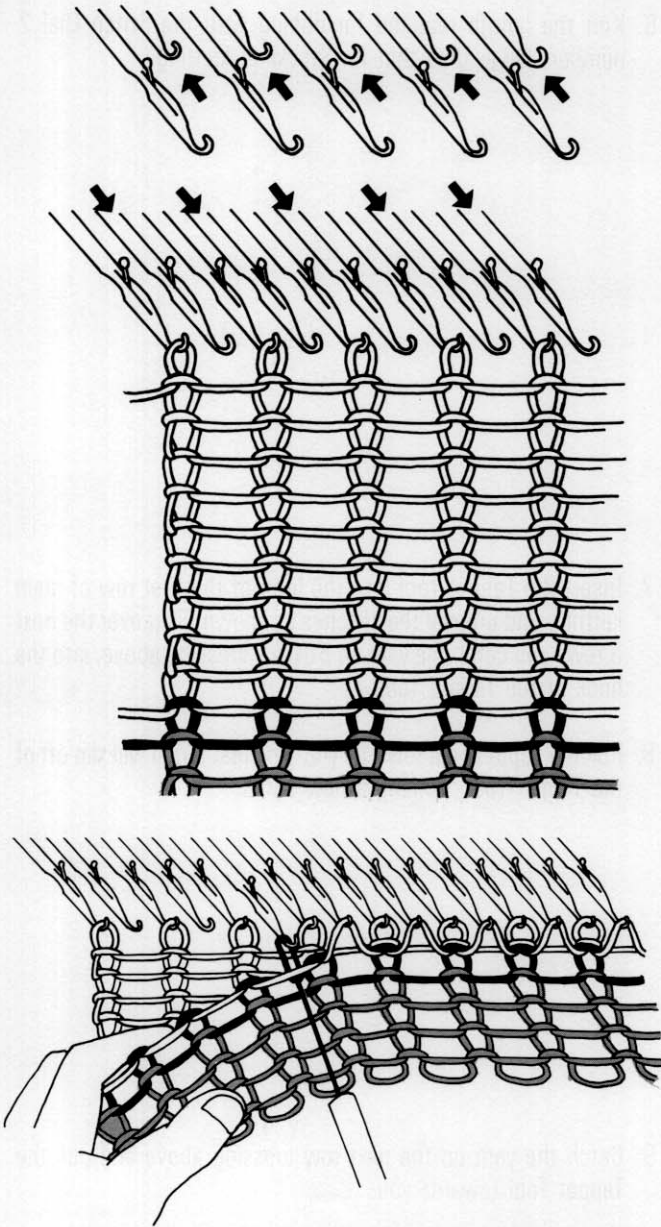

1. Push the required number of needles to B position and push back every other needle to A position starting with the second needle from the left side.
2. Cast-on and knit several rows of waste knitting.
Knit 1 row with Ravel Cord "A".
3. Thread the main yarn and set the Stitch Dial 3 — 4 numbers lower than that for stockinet, and knit twice the number of rows required for the depth of the welt.
4. Push the needles that were pushed back to A position in step 1, to B position.
5. Pick up the sinker loops on the first row of the main knitting using Transfer Tool, and place them onto the empty needles in B position.
6. Re-set the Stitch Dial to the number used for stockinet knitting and continue to knit.
Pull out the Ravel Cord to remove the waste knitting.

When ironing, insert a ruler-like object into the side opening of the ribbed knitting and stretch the fabric vertically.

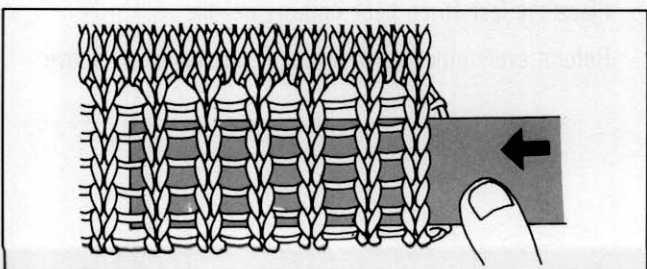

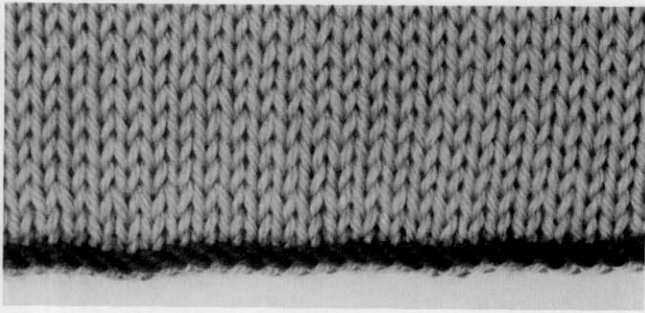

Cast-on by winding yarn

1. Cast-on with waste yarn and knit several rows ending with the Carriage at the left. Then knit 1 row with the Ravel Cord.

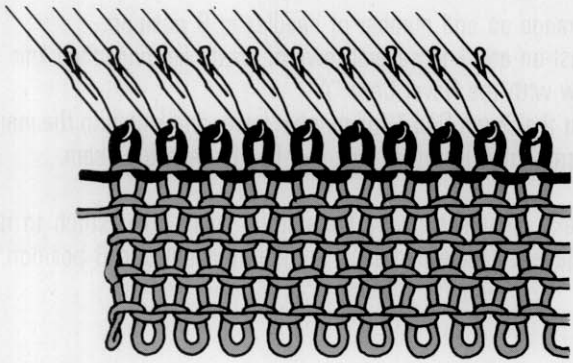

2. Push the needles to D position.

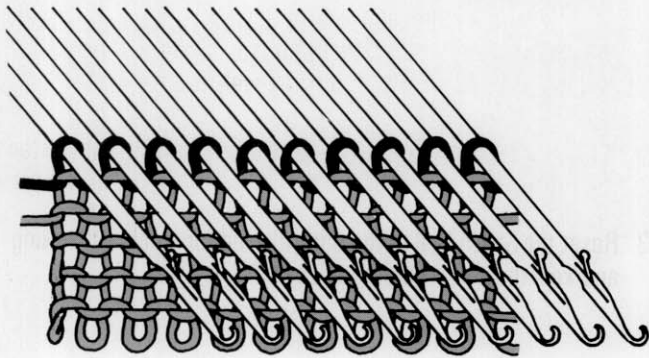

3. Wind the main yarn around the needles in an anticlockwise direction, starting from the left.

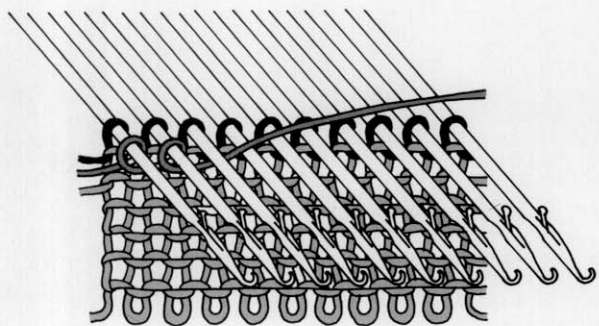

4. Thread the main yarn through the Yarn Feeder.

5. Set both Russel Levers to the II, and continue to knit.

* After knitting 6 — 7 rows of the main yarn, pull out the Ravel Cord.

The cast-on row is closed.

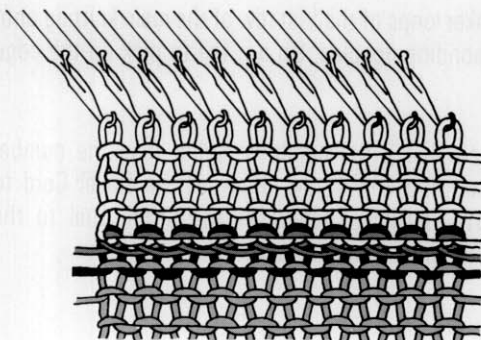

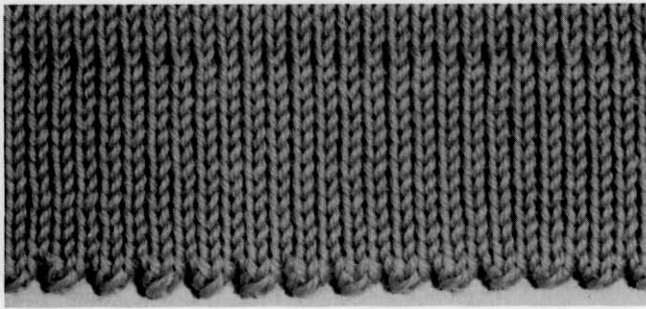

Picot hem

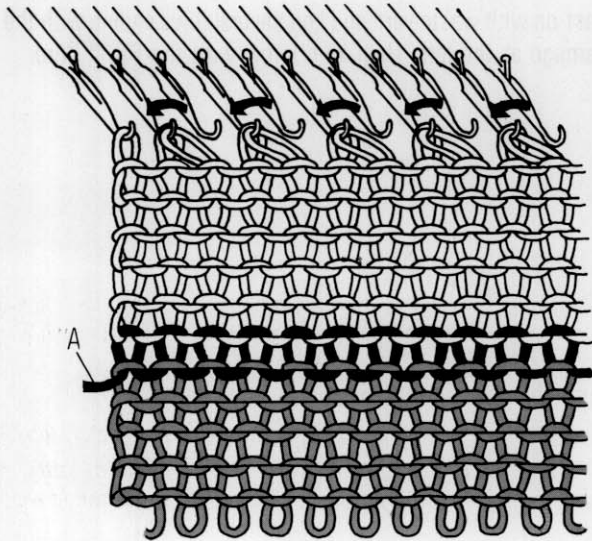

1. Arrange an odd number of needles in B position. Cast-on and knit several rows of waste knitting, then knit 1 row with the Ravel Cord "A". Set the Stitch Dial 1 full number lower and knit with the main yarn, 1 row less than required for the length of hem.
2. Make picot eyelets by transferring every other stitch to its adjacent needle and align the empty needles in B position.

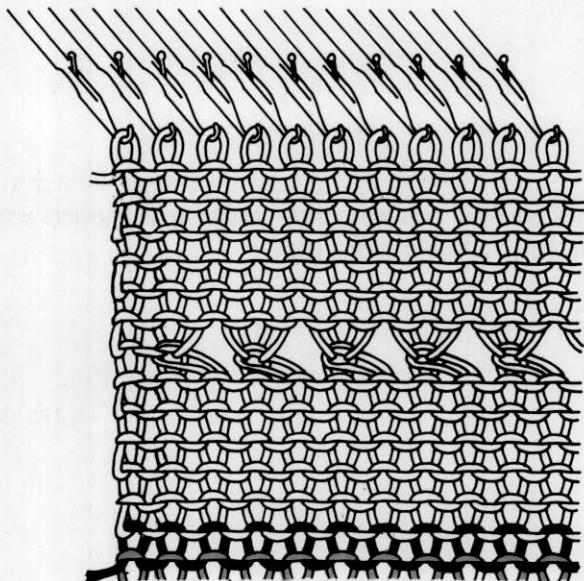

3. Reset the Stitch Dial to the original used for stockinet knitting and knit the same number of rows.

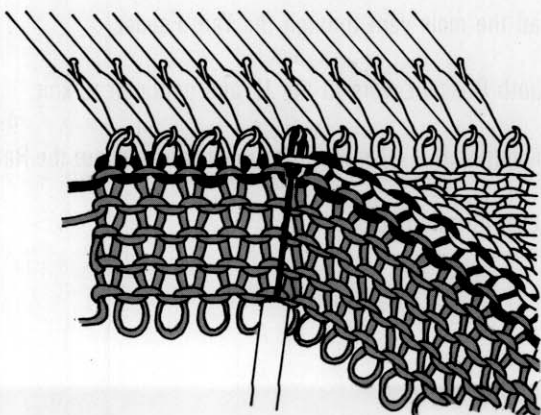

4. Place the sinker loops of the first row of the main knitting onto their corresponding needles. Do not fail to pick up the edge sinker loop.
5. Set the Stitch Dial 2 full numbers higher than the number originally used and knit 1 row. Pull out the Ravel Cord to remove waste knitting. Then reset the Stitch Dial to the original number and continue to knit.

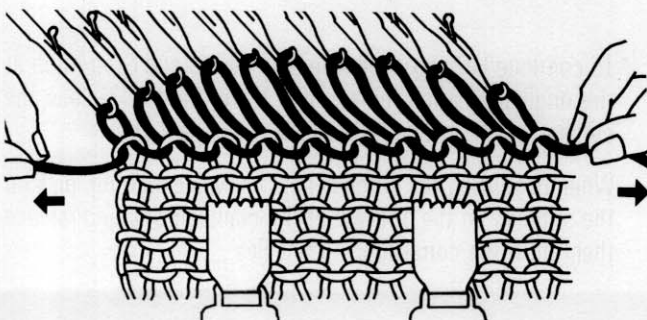
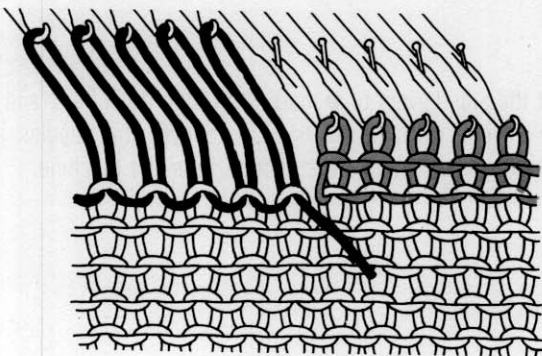
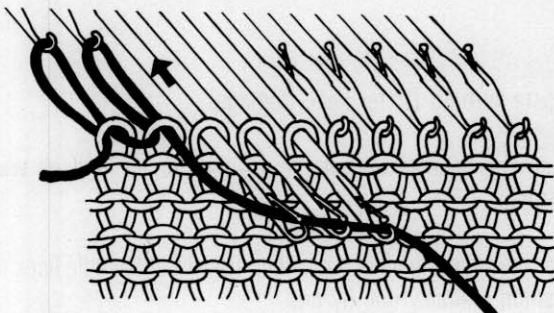
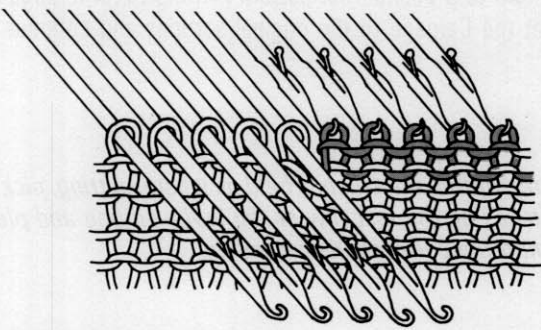
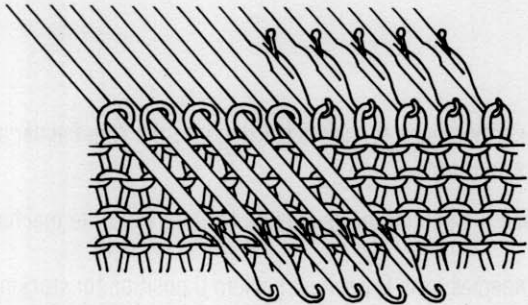
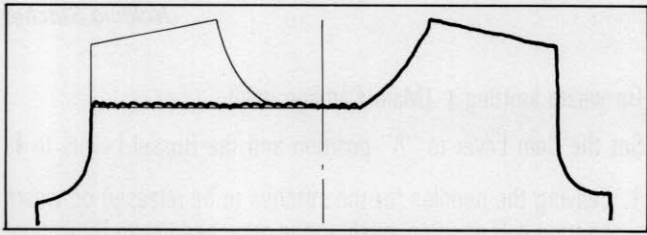

Holding stitches

If it is necessary to shape a garment in sections, use one of the following methods.

In D position (Main Carriage only)

1. Push the needles for the section to be held to D position.

2. Set the Russel Lever to **I**, and continue to knit.

To knit again for the stitches which have been in holding position, push the needles back to C position, and continue to knit.

When pattern knitting is in progress, push the needles which have been in holding position back to B position using a Transfer Tool, replacing their stitches correctly back in their hooks.

Using Ravel Cord

1. Push the needles for the section to be held, to D position, and lay the Ravel Cord across the hooks.

2. Starting from the end needle, knit Ravel Cord needle back to A position manually one by one.

3. Continue to knit.

Before knitting each row, make sure that the needles are correctly placed in A position.

To bring the needles back into B position, hang Claw Weights on the fabric and replace the stitches in needle hooks by pulling up the Ravel Cord.

Holding Stitches

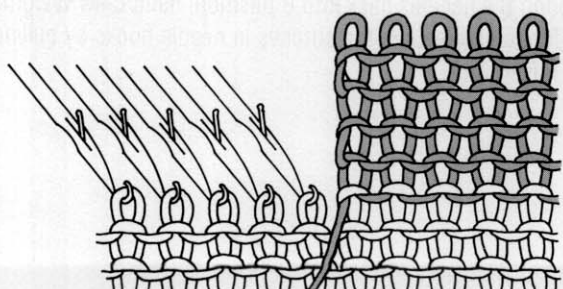
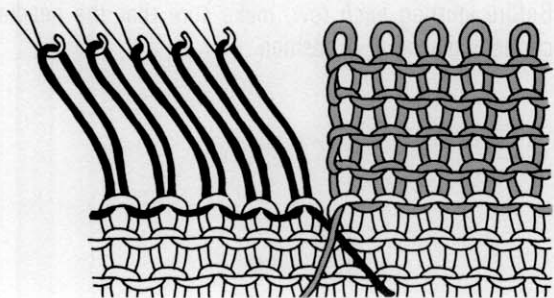
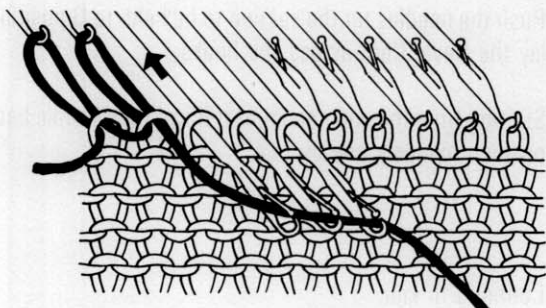
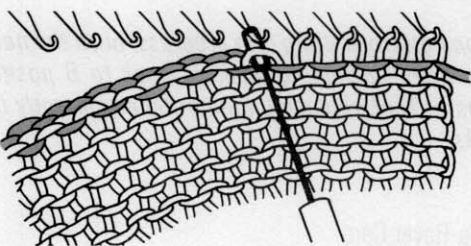
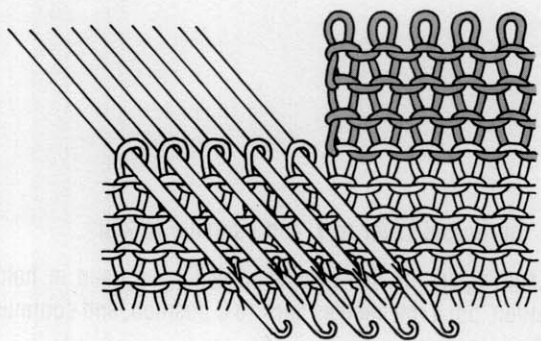
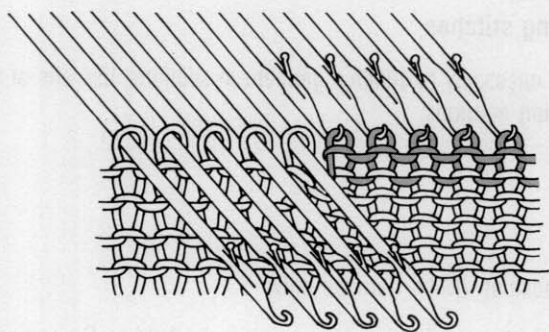

On waste knitting **I** (Main Carriage only)

Set the Cam Lever to "A" position and the Russel Levers to **I**.

1. Leaving the needles for the stitches to be released on waste knitting in B position, push up the other needles to D position.

2. Set a contrast yarn for waste knitting into the Yarn Feeder and knit several rows.

Remove the section on the waste knitting from the machine.

3. Push needles from D position back to C position for stockinet, or return to B position for pattern knitting (refer to page 5). Reset the Carriage to the original settings and continue to knit.

When re-knitting the stitches held on waste knitting, pick up the stitches on the last row of the main knitting and place them onto the corresponding needles.

On waste knitting **II** (for Lace Carriage)

1. Push the needles except the stitches to be held on waste knitting.

2. Starting from the end needle, knit Ravel Cord needle back to A position manually one by one.

3. Set the Side Levers to ● mark, stop the Punch Card, and knit the several rows of waste knitting over the needles in B position. Then remove the section from the machine.

* To continue knitting, reset the Side Levers and Stop Knob at the original position, unravel the Ravel Cord to replace the stitches in the needle hooks (refer to page 14).

When re-knitting the stitches held on waste knitting, pick up the stitches on the 1st row of the main knitting and replace them onto the corresponding needles.

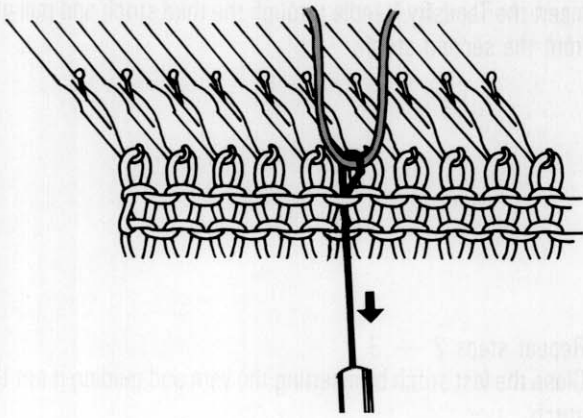

Put the yarn mark

Insert the Tappet Tool into the sinker loop that is to be marked, and by taking a piece of waste yarn, form a loop on the Tappet Tool. Pull the Tappet Tool through the sinker loop.

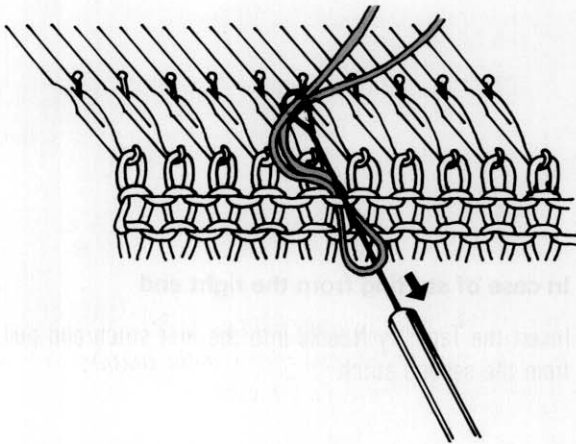

Catch both ends of the waste yarn and pull out the Tappet Tool through the loop.

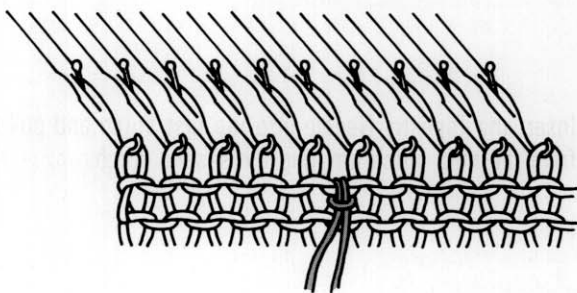

Cast off using Back Stitch method

A. In case of starting from the left end

1. Thread the Tapestry Needle and insert it into the first stitch and pull the yarn through.
2. Insert the Tapestry Needle through the second stitch and pull out from the first stitch.

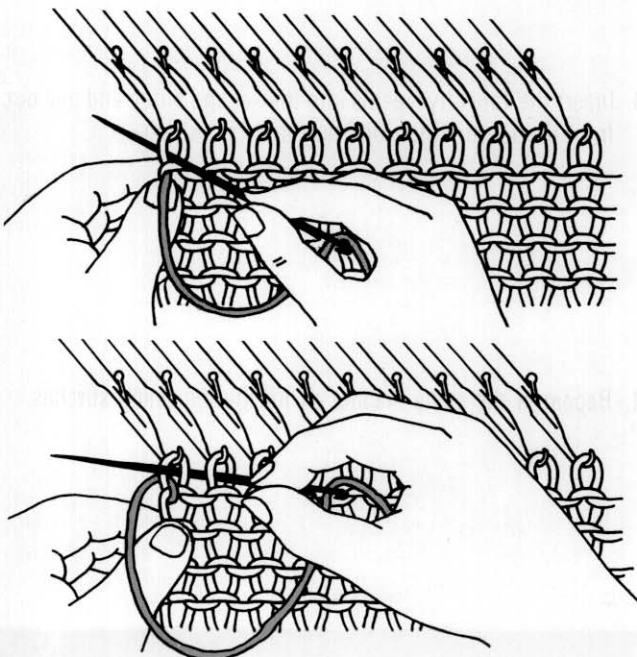

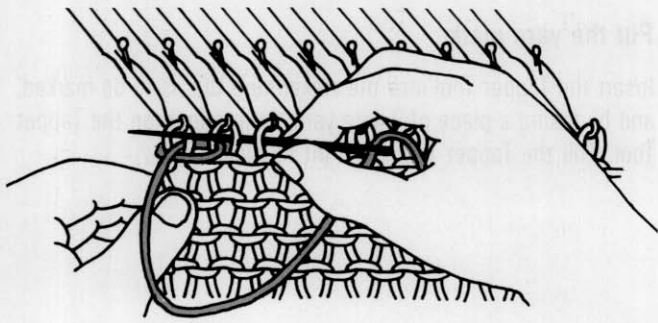

3. Insert the Tapestry Needle through the third stitch and pull out from the second stitch.

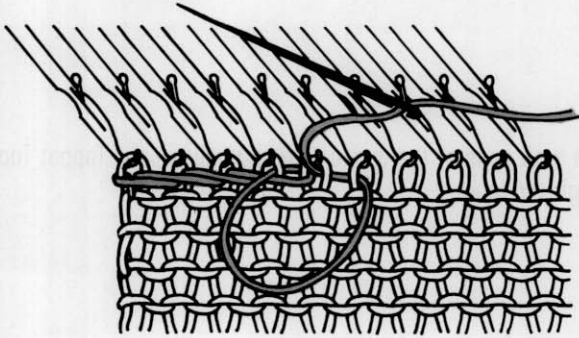

4. Repeat steps 2 — 3.
Close the last stitch by inserting the yarn and guiding it out the stitch.

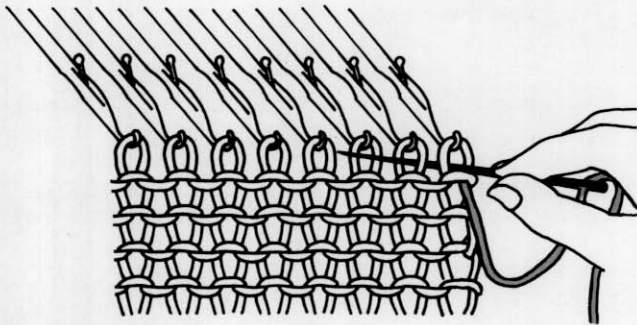

B. In case of starting from the right end

1. Insert the Tapestry Needle into the first stitch and pull out from the second stitch.

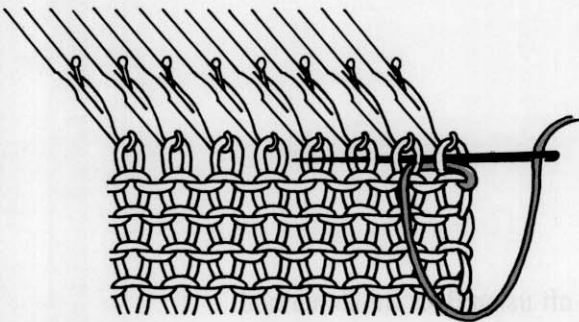

2. Insert the Tapestry Needle into the first stitch and pull out from the third stitch omitting the second stitch.

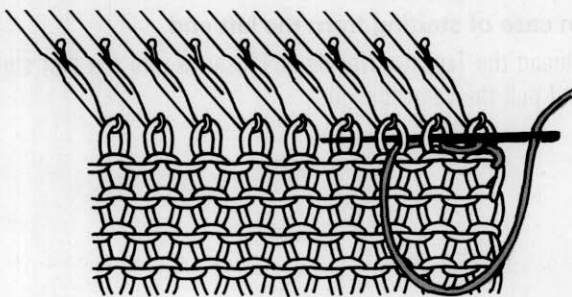

3. Insert the Tapestry Needle into the second stitch and pull out from the fourth stitch omitting the third stitch.

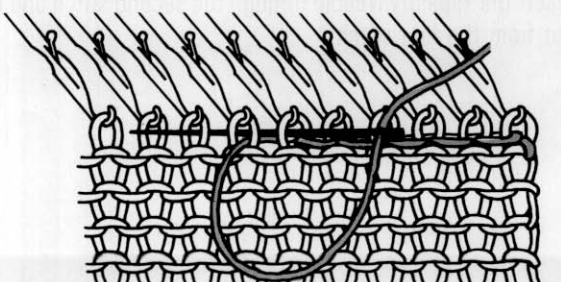

4. Repeat in the same manner as for the remaining stitches.

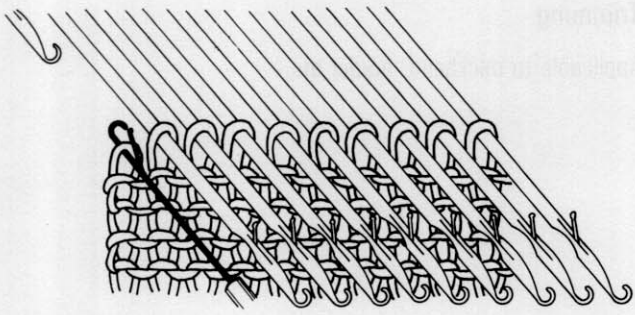

Cast off with Tappet Tool

This is used for closing the stitch when main knitting is completed.

1. Knit the cast off row with the Main Carriage, setting the Stitch Dial 3 — 4 numbers higher, then push the needles to D position. On the side opposite the Carriage, hook the first stitch with the Tappet Tool and push back the needle to A position. The stitch is transferred onto the Tappet Tool.

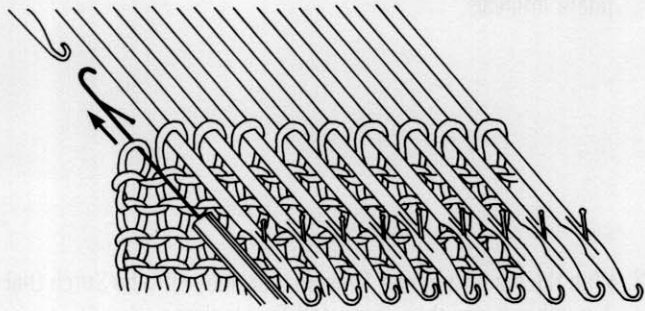

2. Place the stitch behind the latch of the Tool.

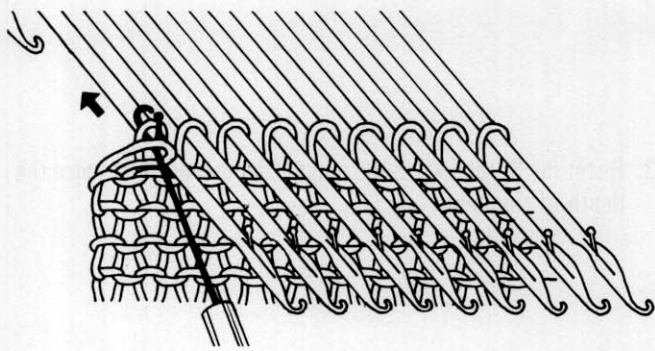

3. Hook the second stitch, push the needle back as indicated by the arrow but pull the Tappet Tool in the opposite direction.

The first stitch will slip off the tool, leaving the second stitch in the hook of the Tappet Tool.

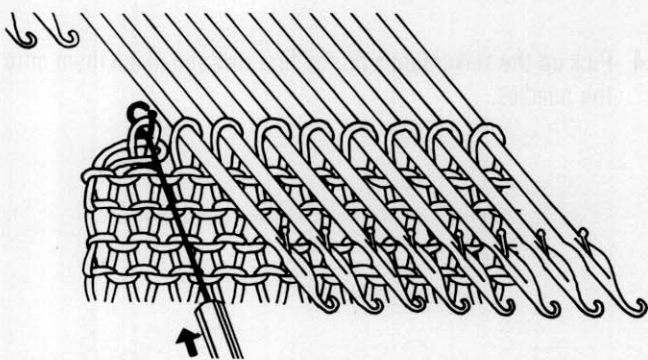

4. Repeat steps 2 — 3.

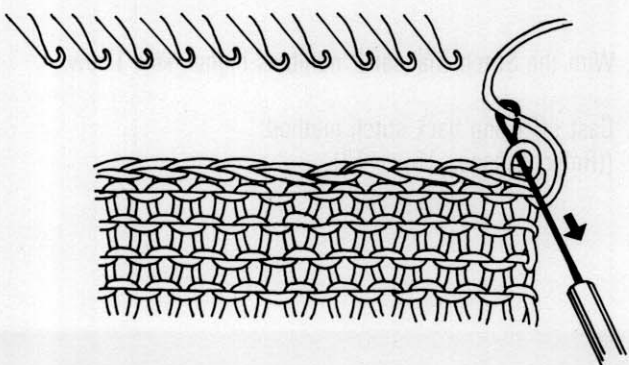

Cast off the last stitch by pulling the yarn end through the stitch with the Tappet Tool as shown.

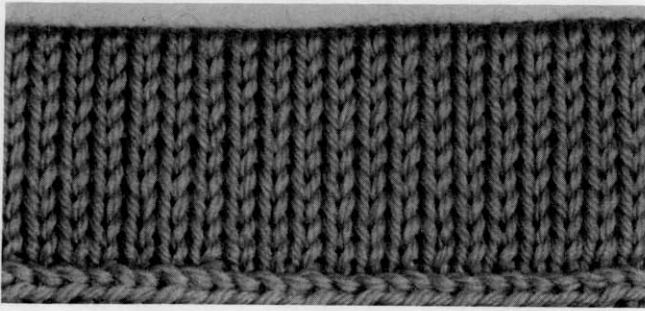

Trimming

Applicable to neckband, border etc.

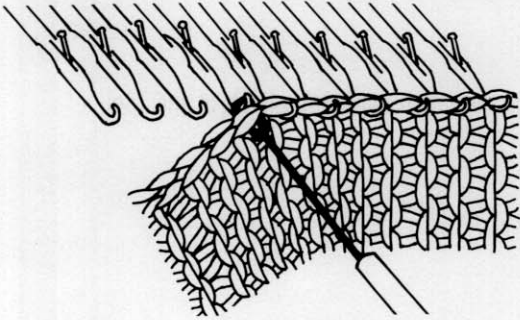

1. With the wrong side facing you, place the stitches of a side edge and place onto the needles, omitting a stitch at appropriate intervals.

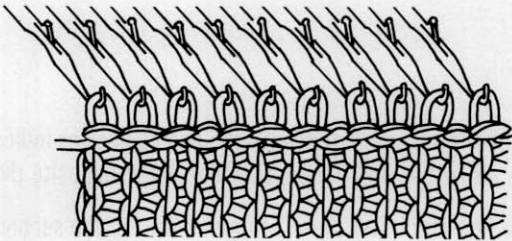

2. With the main yarn, knit 1 row in stockinet with the Stitch Dial 1 number lower than that used for stockinet.

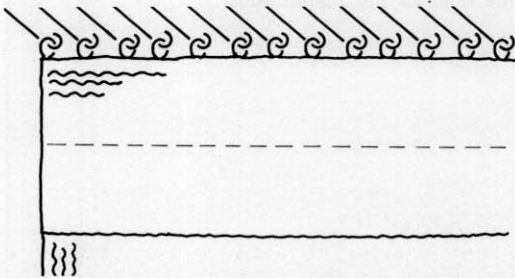

3. Reset the Stitch Dial to the original number and knit twice the depth of the hem.

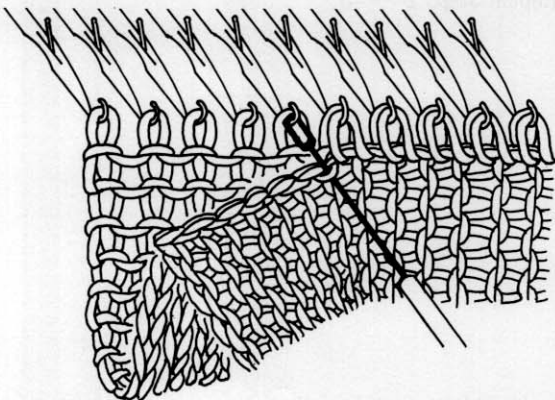

4. Pick up the sinker loops on the first row and place them onto the needles.

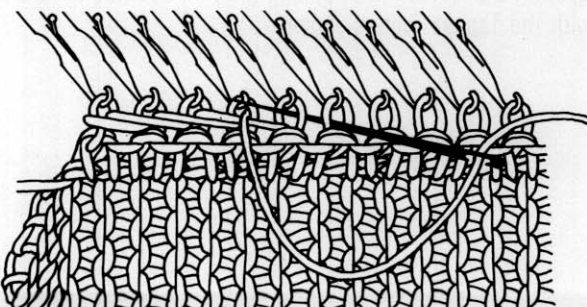

5. With the Stitch Dial set 2 numbers higher, knit 1 row.

6. Cast off using back stitch method.
(Refer to pages 16 ~ 17).

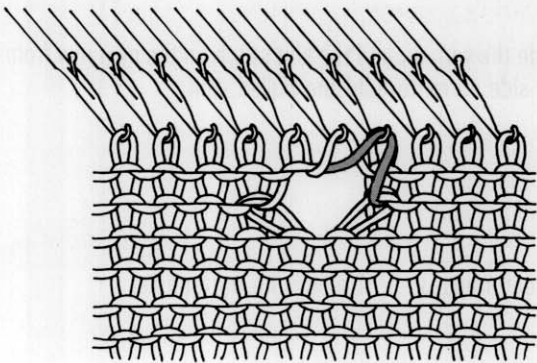
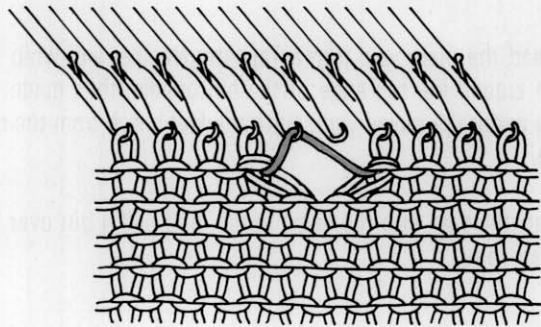
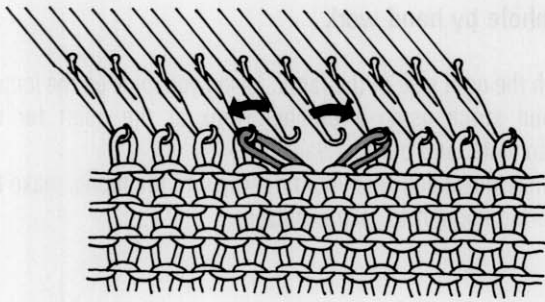

Buttonhole by transferring stitches

Double stitch eyelet

1. Transfer 2 stitches onto their adjacent needles respectively, as shown.
Leave the empty needles in B position.
Knit 1 row.
2. Remove the hooked yarn from the right side needle.
Knit 1 row.
3. Pick up the yarn crossing above and place it onto the needle as shown.
Continue to knit up to the next buttonhole.

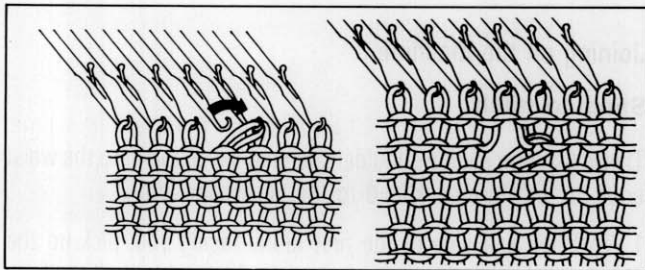

Single stitch eyelet

Place 1 stitch onto its adjacent needle. Leave the empty needle in B position. Continue to knit.

When making buttonholes on a double border, adjust the number of rows or stitches in between the inside buttonholes and outside buttonholes so that they correspond when the border is folded.

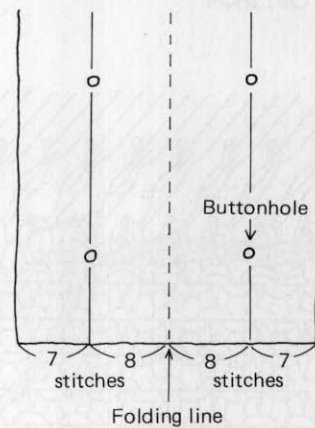
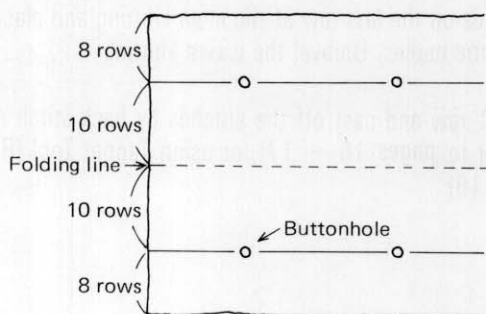

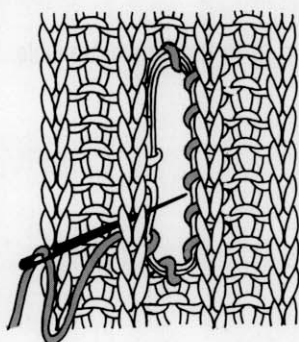
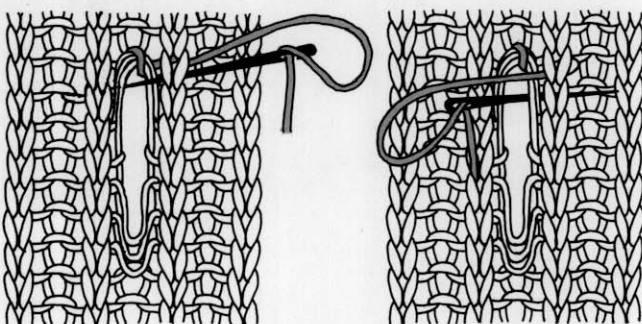
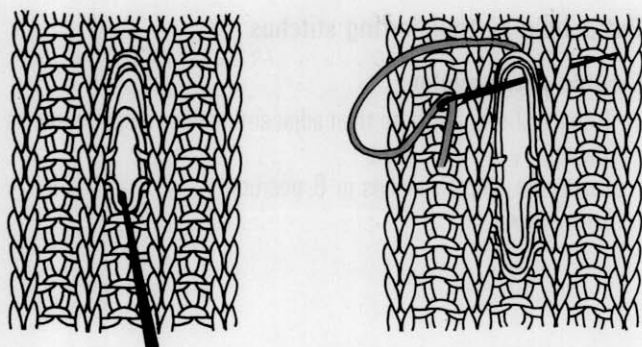

Buttonhole by hand work

1. With the right side of the fabric facing you, pick up the loop of a purl stitch using a Crochet Hook at the point for the buttonhole, and pull the yarn.
By inserting a pencil or your fingertip into the fabric, make the hole big enough to take a button.
2. Thread the main yarn into a Tapestry Needle, and wrap the yarn around the top edge of the buttonhole, then guide the yarn under the pulled yarns, into the knit stitch from the rear side.
3. Insert the yarn into the same stitch, and pull it out over the pulled yarns.
4. Guide the yarn around the knit stitch on the next row from the rear side so as to hold the pulled yarn.
5. Repeat steps 3 — 4 along the buttonhole.

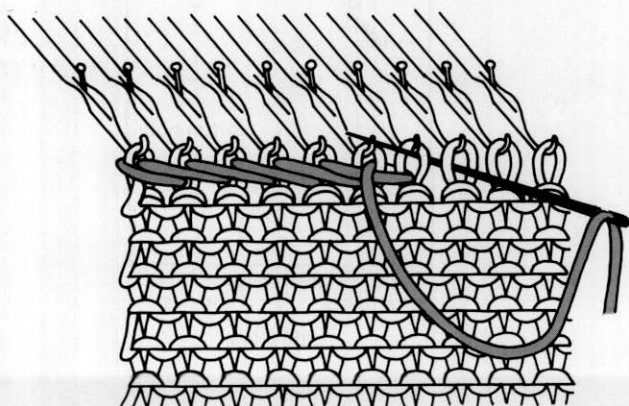
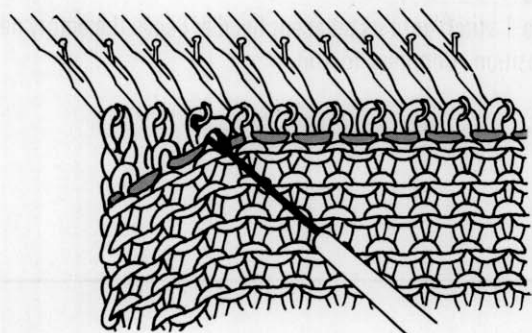

Joining on the machine

Stitch to stitch

This is used for joining shoulders, joining a waistband to the waist edge, or joining a neckband to the neck edge, etc.

1. With the knit side of the first fabric facing you, pick up the stitches on the last row of the main knitting and place them onto the needles. Unravel the waste knitting.
2. With the purl side of the second fabric facing you, pick up the stitches on the last row of the main knitting and place them onto the needles. Unravel the waste knitting.
3. Knit 1 row and cast off the stitches by back stitch method (Refer to pages 16 ~ 17), or using Tappet Tool (Refer to page 18).

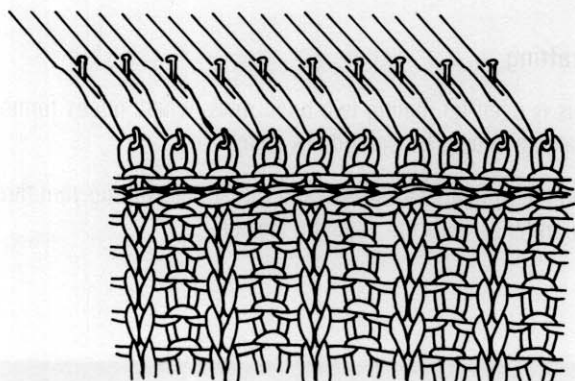
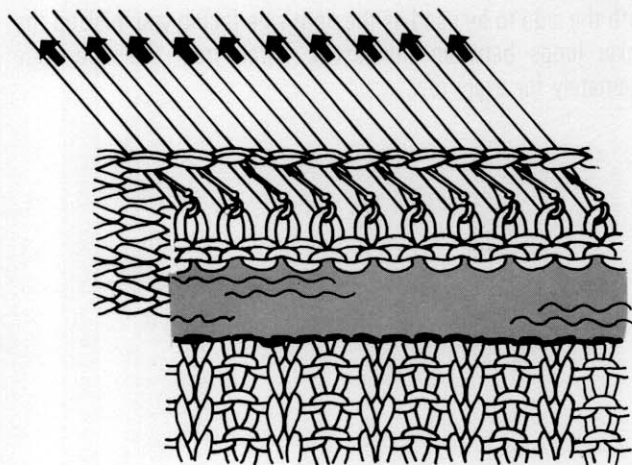
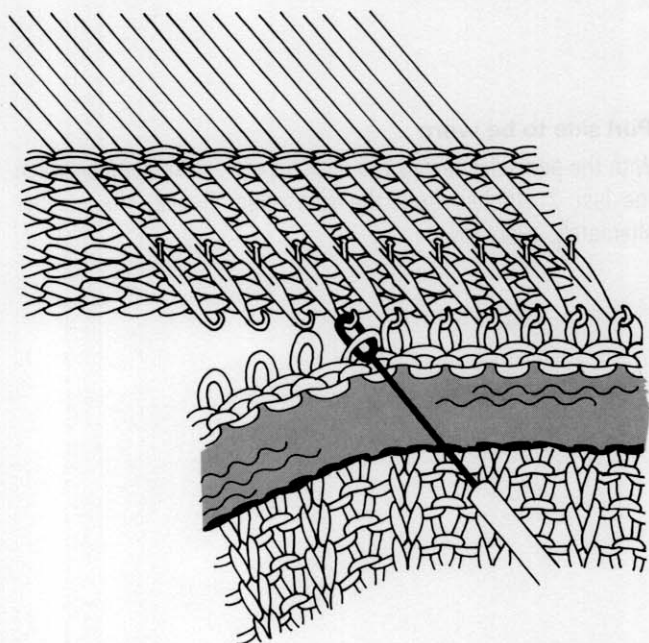
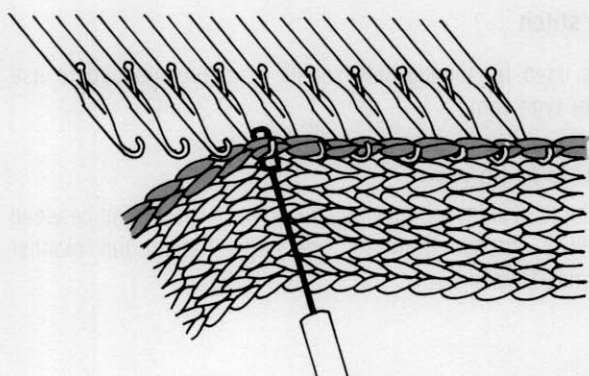

Open stitches to side edge

This is used for joining borders to the front centre edge of a cardigan, neckband to the neck edge, etc.

1. With the knit side of the first fabric facing you, pick up the stitches on the side edge, omitting a stitch at appropriate intervals, and place them onto the needles.
2. Push up the needles to D position. With the wrong side of the second fabric facing you, pick up the stitches on the last row of the main knitting, and place them onto the same needles.

3. Push back the needles to B position.
4. The stitches behind the latches will slip off of the needles. Unravel the waste knitting.

5. Knit 1 row and cast off the stitches by back stitch method (Refer to pages 16 ~ 17), or using Tappet Tool (Refer to page 18).

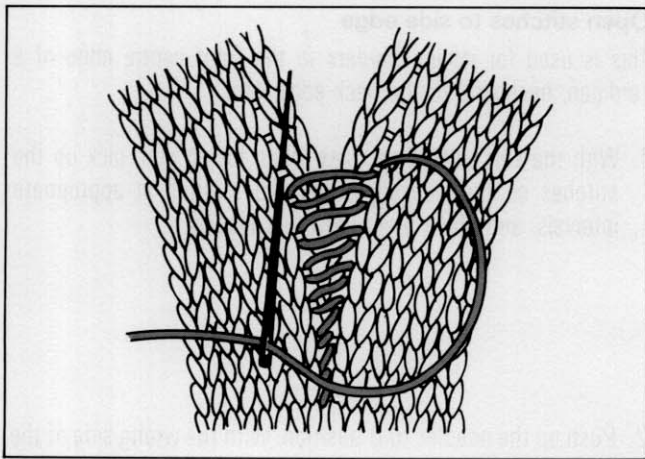

Blind stitch

This is used for joining side seams. It is recommended to use medium type yarn.

Knit side to be worn.

With the right sides facing you, pick up each sinker loop between the last 2 stitches from the side edge. Repeat this manner alternately for every row.

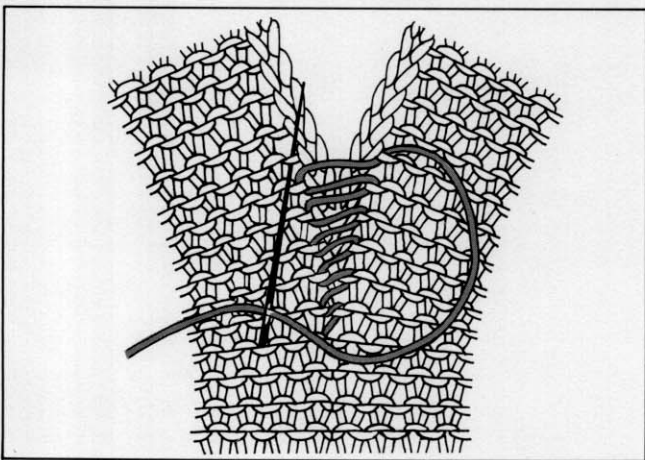

Purl side to be worn

With the purl sides facing you, pick up each sinker loop between the last 2 stitches from the side edge. Repeat the manner alternately, every row.

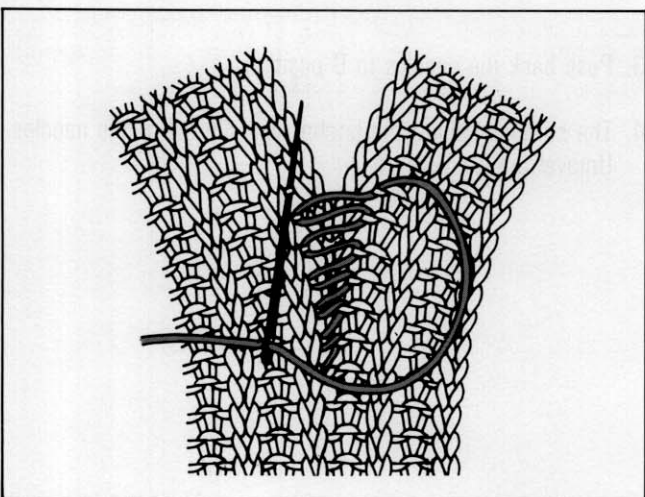

K1.P1. Rib

With the side to be used as the right side facing you, pick up the sinker loops between the last 2 stitches from the side edge alternately for every row.

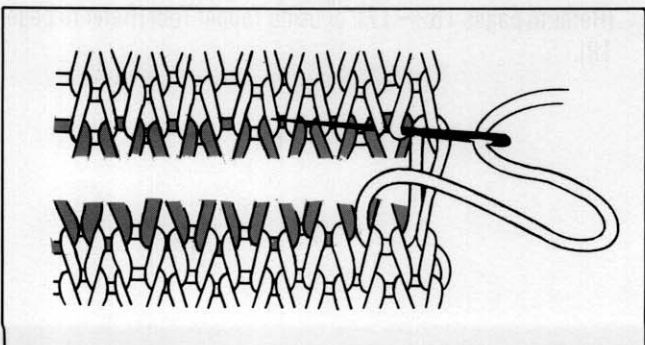

Grafting

This is used for joining two open rows, where ridges formed by seaming should be soft to the touch.

Align both fabrics as shown and thread the knitting yarn through the stitches with the Tapestry Needle.

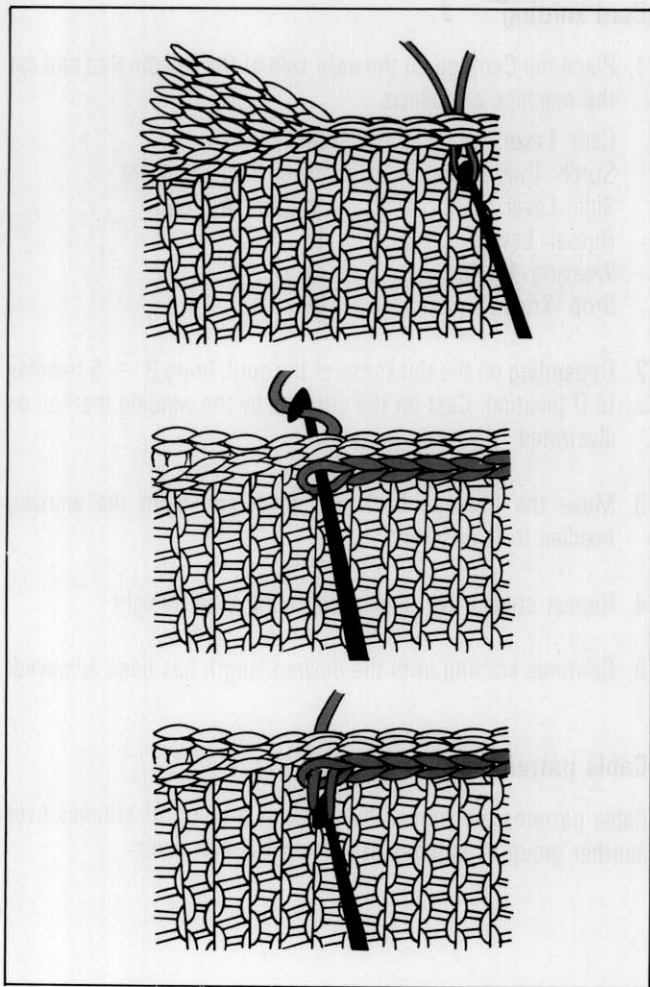

Slip stitch

This is used for setting in the sleeves or joining side seams.

1. Place the fabric to be joined with the right sides facing each other. Insert the Crochet Hook into each sinker loop between the last 2 stitches from the side edge and catch the yarn, pull it through.

2. Insert the Crochet Hook into the next loop and catch the yarn.

3. Pull back the Crochet Hook.

Repeat steps 2 — 3.

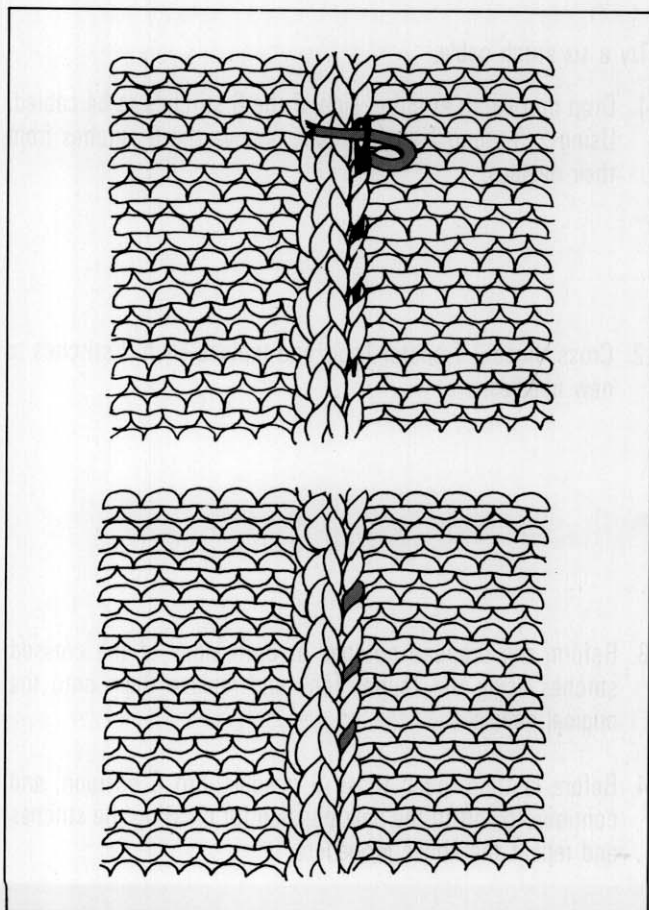

Sew in yarn ends

Oversew the yarn ends into the seam.

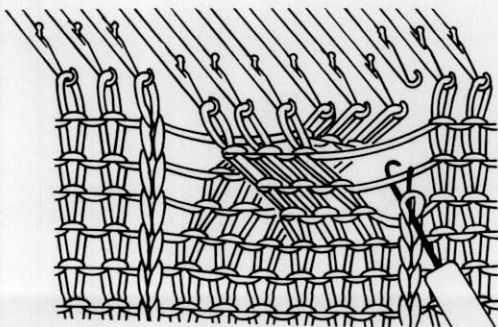
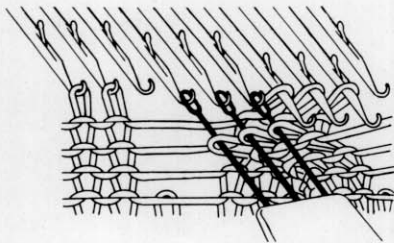
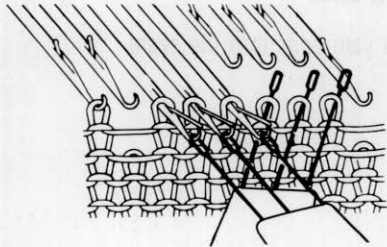
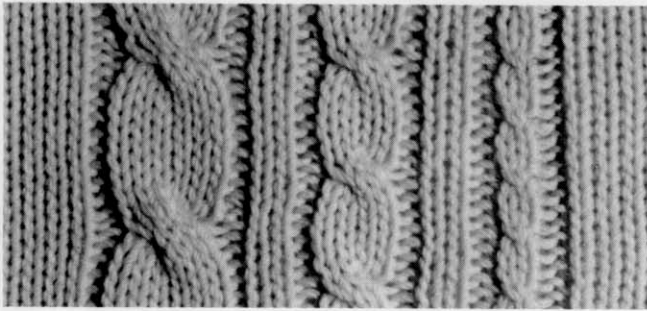
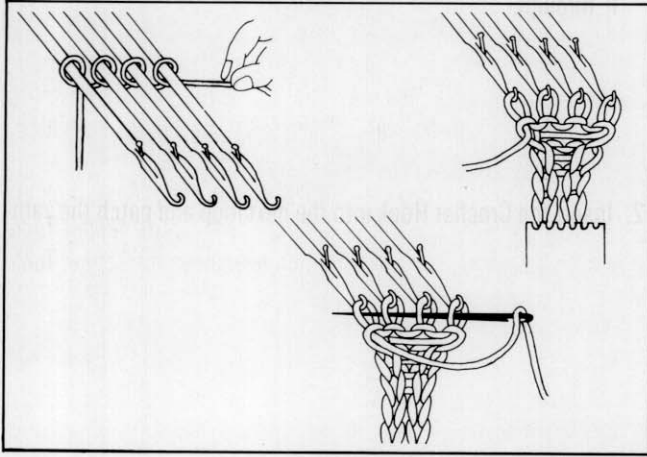
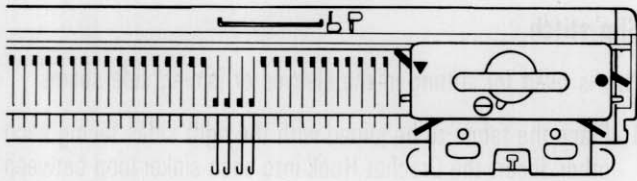

Cord knitting

1. Place the Carriage on the right side of the Needle Bed and set the machine as follows.

- Cam Lever.....⊖
- Stitch Dial.....lower than Stockinet
- Side Lever.....▼ (left) ● (right)
- Russel Levers.....||
- Weaving Knobs.....○
- Stop Knob.....●

2. Depending on the thickness of the cord, bring 3 — 5 needles to D position. Cast-on the stitches by the winding method as illustrated.

3. Move the Carriage back and forth and push the working needles to D position.

4. Repeat step 3 five times, then hang Claw Weight.

5. Continue knitting until the desired length has been achieved.

Cable pattern

Cable patterns are formed by crossing a group of stitches over another group of stitches using two Transfer Tools.

Try a six stitch cable.

1. Drop one stitch at either side of the 6 stitches to be cabled. Using 2 3-prong Transfer Tools, remove the 6 stitches from their needles.

2. Cross those 2 Transfer Tools and replace each 3 stitches to new needles.

3. Reform the dropped stitches at both sides of the crossed stitches using the Tappet Tool, and replace them onto the original needle.

4. Before knitting, push those 6 needles into C position, and continue to knit to the next position for crossing the stitches and repeat the above procedure.

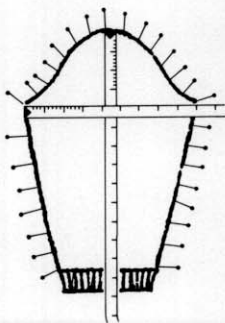
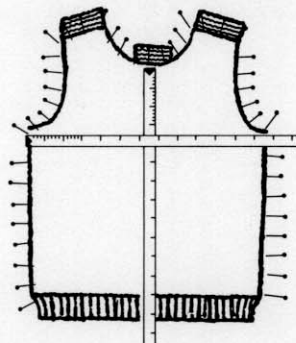
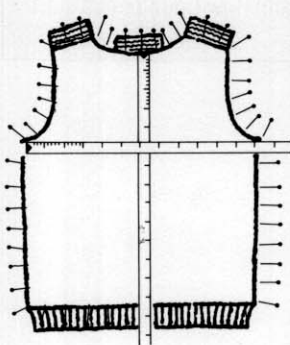
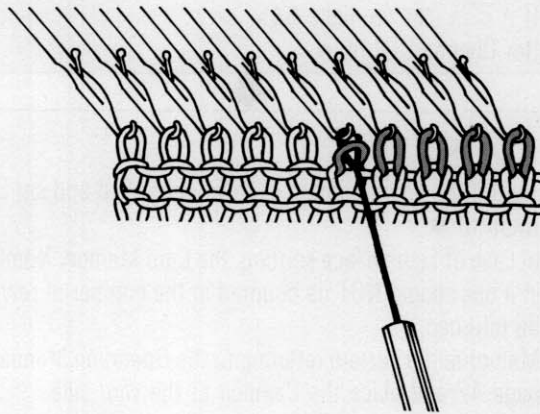
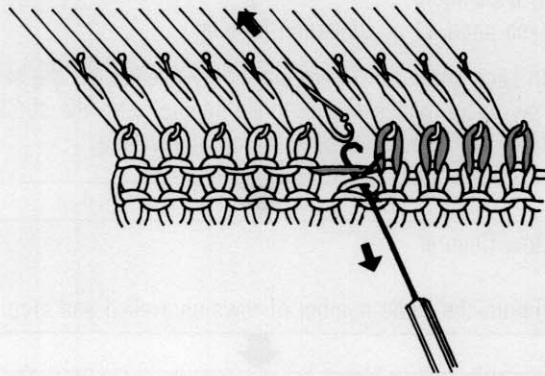
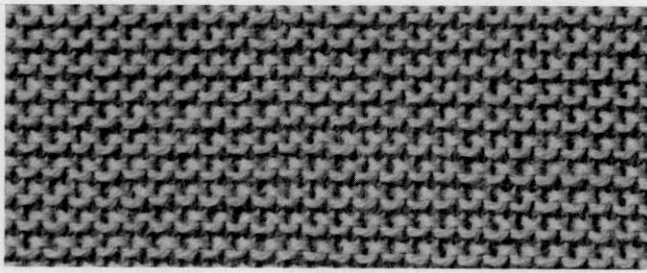

Garter stitch

Garter stitch is used for laps, collars, border, etc.

Knit stockinet purling the stitches every other row.

1. Set the Stitch Dial 2 numbers lower than for Stockinet knitting.
Knit 2 rows stockinet.

2. Insert the Tappet Tool into the stitch below that which is hooked on the needle, and push the needle to D position.

3. Push the needle back to B position, allowing the stitch to come undone. Catch the loop in the hook of the Tappet Tool, and pull the loop through the stitch already on the Tappet Tool.

4. Place the newly formed stitch back onto the needle.

Repeat steps 2 — 4 for all stitches on the row.

5. Knit 2 rows of stockinet and re-form the stitches on the second row in the same manner as done in steps 2 — 4.

Blocking and pressing

After knitting the pieces of your garment, you must lay them flat and pin them out to their correct shape and size.

1. Pin out a piece with its wrong side facing up on an ironing board at the widest point, afterwards pinning it to its correct length.

2. Pin all around the edges, spacing the pins about 2 — 3cm. apart. (Place the pins inside the ribbed edge.)

3. Press them lightly with a steam iron or over a damp cloth.

4. Leave the pieces to dry before removing the pins.

IF MISTAKES OCCUR DURING KNITTING

Stockinet knitting

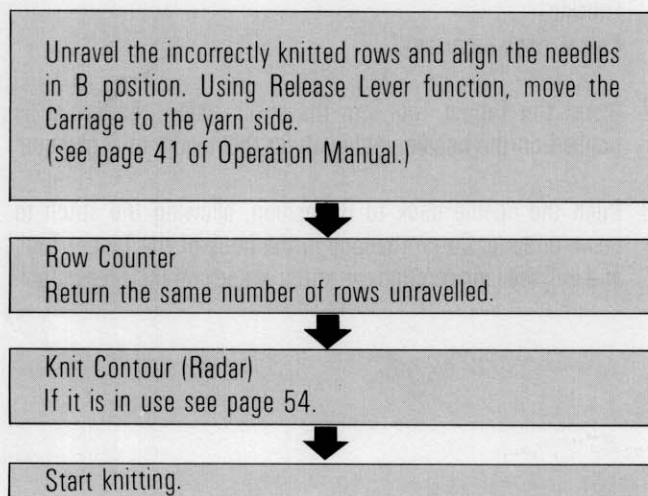

Vertical expansion

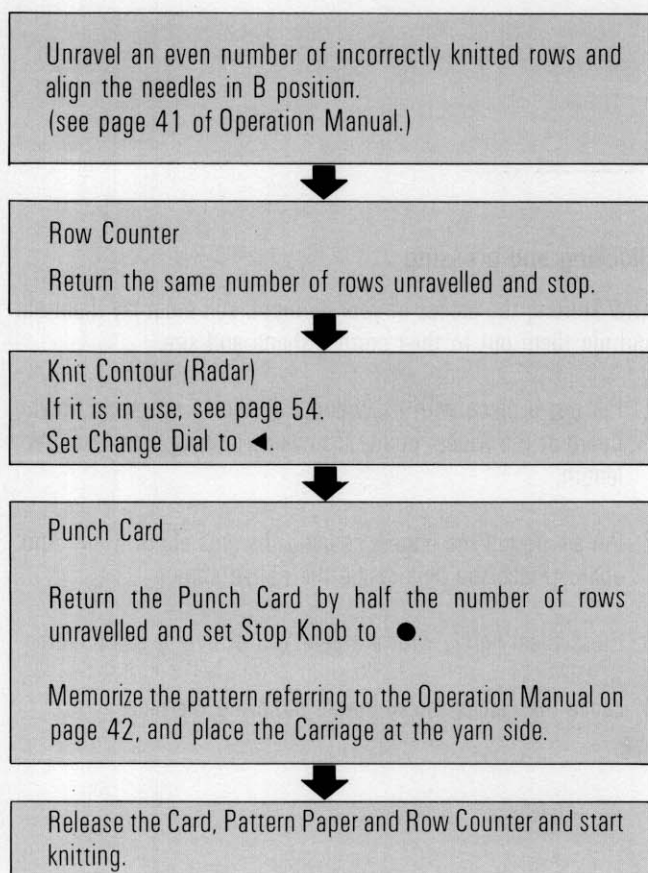

Pattern Knitting

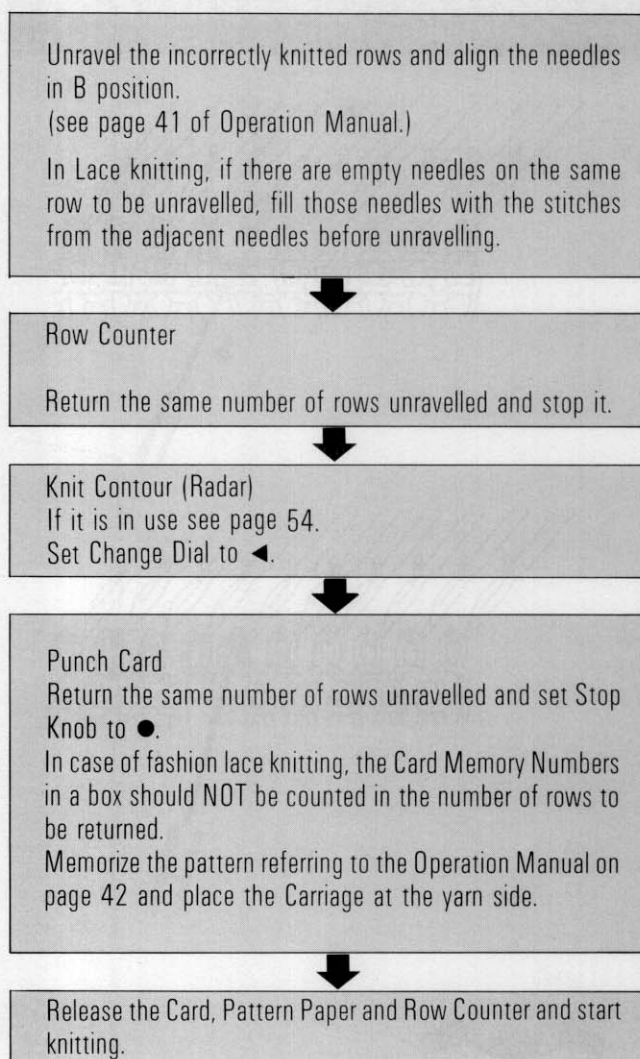

KNITTING WITHOUT USING THE KNIT CONTOUR

The instructions below explain how to knit a lady's pullover. This is an example based on the size, and the tension gauge as shown below.

Measurements of finished garment:

Bust	94cm.
Length	59cm.
Back width	36cm.
Sleeve Length	56cm.

Material needed:

4-ply (medium) yarn 400gs.

Tension Gauge:

32 stitches by 44 rows to 10cm. sq. measured over stockinet with Stitch Dial at ⑥.

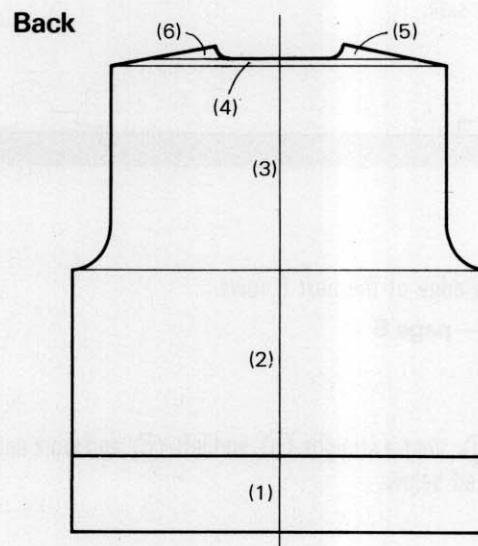

(1) welt

— Arrange 150 needles and knit welt by K1.P1. Rib or Mock Rib.

K1.P1. Rib — pages 9 ~ 10

On step 3, knit 4 rows starting from the right side, and on step 6, knit 24 rows.

If you have Ribbing Attachment...

Swing Indicator.....5
 Half Pitch Lever.....P
 Stitch Dial.....⑥
 Cast-on with main yarn for K1.P1. Rib.

Stitch Dial at ③ — ④, knit 24 rows and have the Carriage at right side.

Transfer all the ribber stitches onto the corresponding knitter needles using Double Eye Transfer Tool. (150 stitches on the knitter.)

Drop the Ribber to its lower position and exchange the Ribber Arm for the Knitter Arm.

Mock Rib — page 11

on step 3, knit 48 rows.

(2) straight up to the armhole

— Row Counter 000, Stitch Dial at ⑥, knit 140 rows without shaping. Carriage at right side.

(3) shape armhole

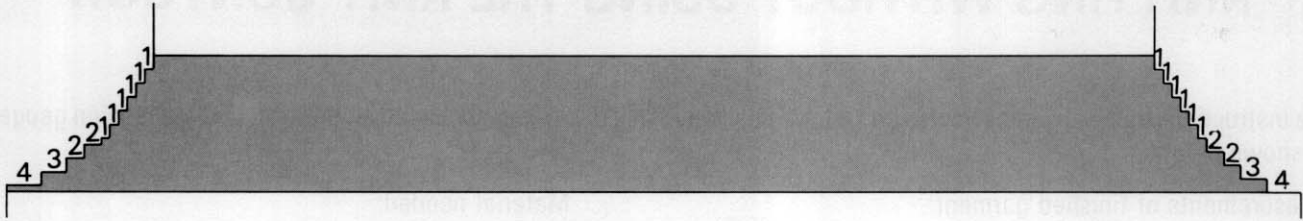

- Decrease 4 stitches at the beginning of the next 2 rows, 3 stitches at the beginning of next 2 rows, and 2 stitches at the beginning of next 4 rows.

Decreasing multiple stitches — page 16 of the Operation Manual.

- Decrease 1 stitch at both ends of the next and every following alternate rows, 6 times in all till Row Counter shows 159.

Decreasing 1 stitch — page 16 of the Operation Manual.

- Knit 62 rows without shaping.
Row Counter at 221 and the Carriage at left side.

(4) shape shoulders by partial knitting

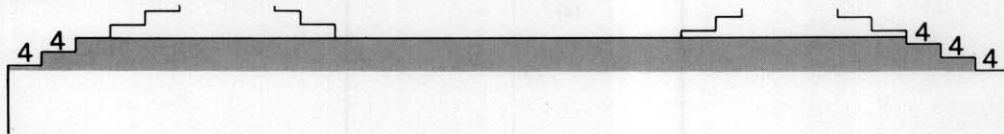

- Set the Russel Levers to **I**.
- Decrease 4 stitches by partial knitting at the edge of the next 5 rows.

Partial knitting by decreasing stitches — page 5

(5) shape neck edge and right shoulder

- At the neck edge, divide into three section, right (a), centre straight (b) and left (c) and work each section separately to shape the neck edge and shoulder at the same time, as instructed below.

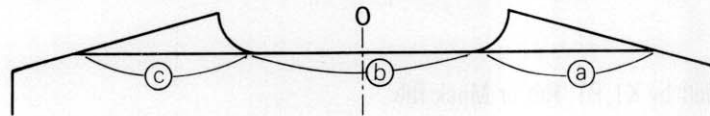

- Hold 70 stitches on sections (b) and (c).

Holding stitches using Ravel Cord — page 14

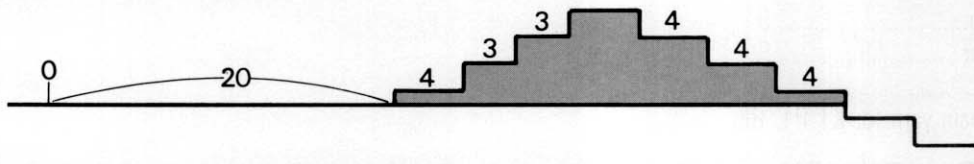

- Knit 1 row and decrease 4 stitches at the beginning of the next row and 4 stitches by partial knitting at the end of the row.

Decreasing multiple stitches — page 16 of the Operation Manual

Partial knitting by decreasing stitches — page 5

- Knit 1 row and decrease 3 stitches at the beginning of the next row and 4 stitches by partial knitting at the end the row. Repeat the manner once more.

- Knit 1 row, Row Counter at 233.

- Break the yarn leaving the end 10cm. and unthread the yarn.

- Push back the needles for the right shoulder to C position.

- With waste yarn, knit several rows and remove the section from the machine.

- Push the empty needles back to A position.

- Push 40 needles on section (b) to B position replacing the stitches in the needle hooks.
- Put a yarn mark at the centre (0) on the fabric.

Put yarn mark — page 16

- Remove the section on waste knitting and push the empty needles back to A position.

(6) shape neck edge and left shoulder

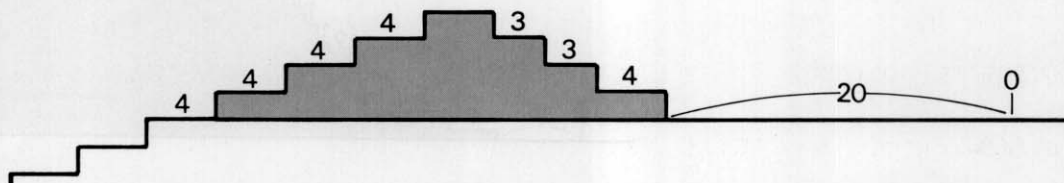

- Have the Carriage on the right side.
- Push 30 needles on section (c) to B position replacing the stitches on the needle hooks.
- Reset the Row Counter to 226.
- Knit 2 rows.
- Decrease 4 stitches at the beginning of the next row and 4 stitches by partial knitting at the end of the row.
- Knit 1 row and decrease 3 stitches at the beginning of the next row and 4 stitches by partial knitting at the end of the row. Repeat the manner once more.
- Knit 1 row.
- Break the yarn leaving the end six times the width of the shoulder, and unthread the yarn.
- Set the Russel Levers to II, knit several rows of waste knitting and remove the fabric from the machine.

Front

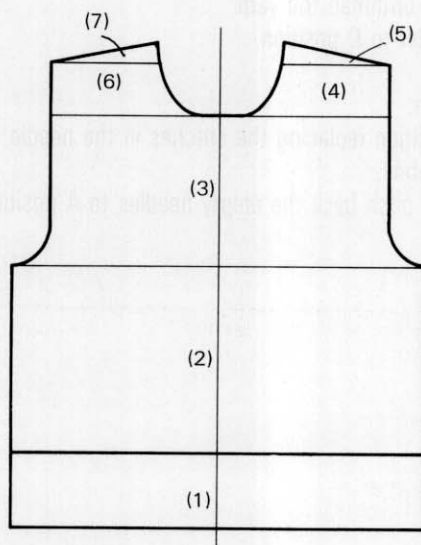

(1) — (2) knit up to armhole

- Knit in the same manner up to armhole as done for back. Row Counter at 140.

(3) shape armhole

- Shape armhole in the same way as for back till Row Counter at 159.
- Knit 33 rows without shaping. Carriage at right side and Row Counter shows at 192.

(4) shape front neck edge of right section.

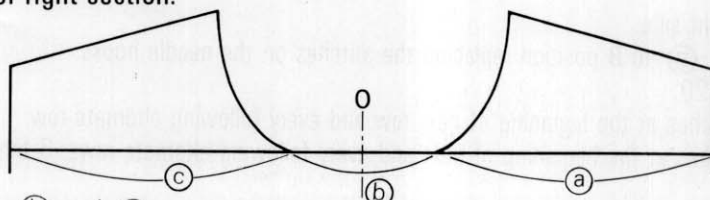

- Hold 65 stitches on section (b) and (c).

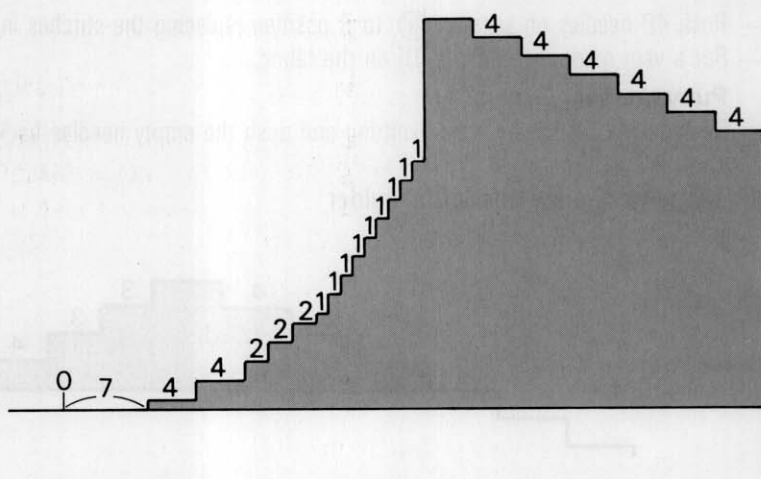

- Knit 1 row, decrease 4 stitches at the beginning of next row and every following alternate row.
- Knit 1 row, decrease 2 stitches at the beginning of next and every following alternate rows, 3 times in all.
- Decrease 1 stitch at the beginning of the next and every following alternate row, 9 times in all.
- Knit 2 rows.
Carriage at the right side and Row Counter at 220.

(5) shape right shoulder by partial knitting.

- Set Russel Levers to **I**.
- Decrease 4 stitch at the end of the next and every following alternate rows, 6 times in all.
- Knit 1 row.
Carriage at left side and Row Counter at 233.
- Break the yarn leaving the end 10cm. and unthread the yarn.
- Push back the needles for the right shoulder to C position.
- Remove the section on waste knitting.
- Push back the empty needles to A position.
- Push 14 needles on section **(D)** to B position replacing the stitches in the needle hooks.
- Put a yarn mark at the centre(0) on the fabric.
- Remove the section on waste knitting and push back the empty needles to A position.

(6) shape front neck edge of left section.

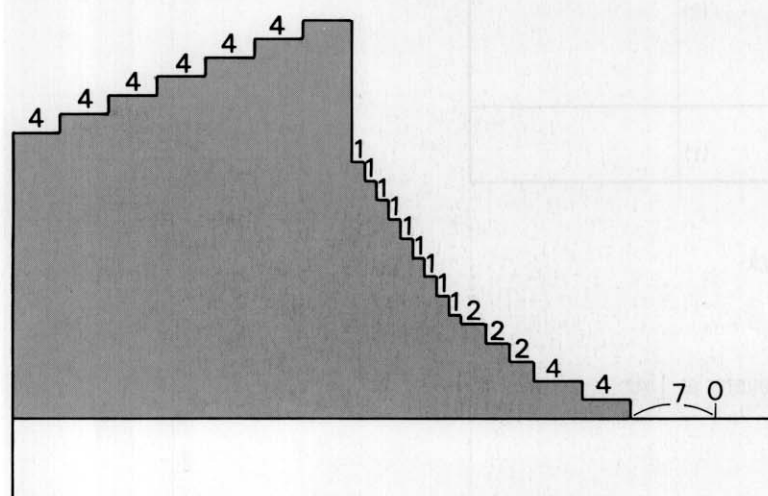

- Have the Carriage on the right side.
- Push 51 needles on section **(C)** to B position replacing the stitches on the needle hooks.
- Reset the Row Counter to 220.
- Knit 2 rows, decrease 4 stitches at the beginning of next row and every following alternate row.
- Knit 1 row, decrease 2 stitches at the beginning of next and every following alternate rows, 3 times in all.

- Decrease 1 stitch at the beginning of next and every following alternate rows, 9 times in all.
- Knit 2 rows.
- Carriage at the right side and Row Counter at 222.

(7) shape left shoulder by partial knitting

- Decrease 4 stitches at the end of the next and every following alternate rows, 6 times in all.
- Knit 1 row.
- Carriage at right side and Row Counter at 234.
- Break the yarn leaving the end six times the width of the shoulder, and unthread the yarn.
- Set the Russel Levers to **II**, knit several rows of waste knitting and remove the fabric from the machine.

Sleeves (both alike)

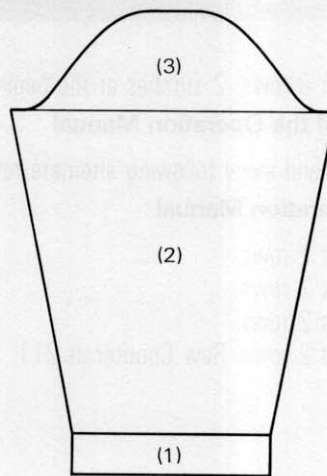

(1) knit cuff

- Arrange 68 needles and knit in the same way as for the waistband.

(2) shape underarm

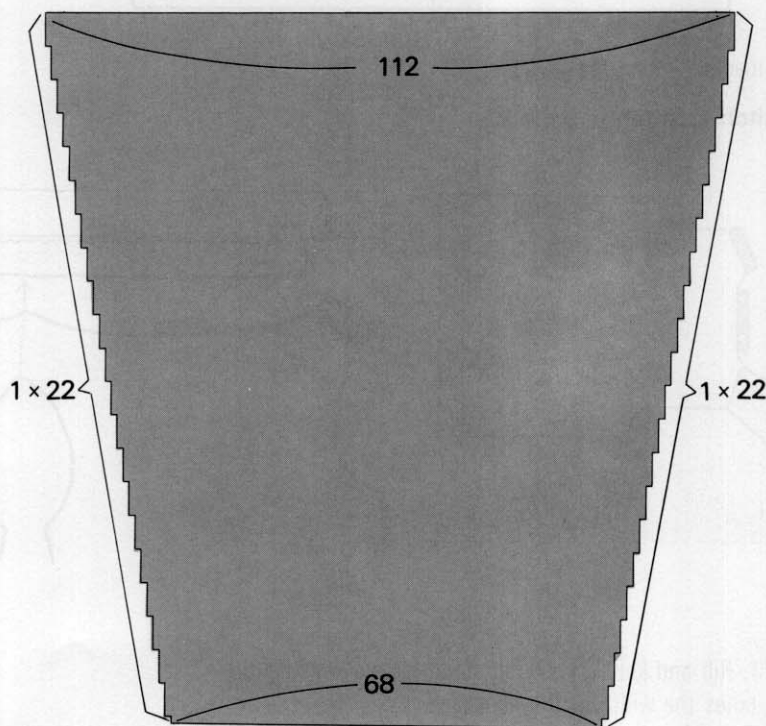

- Row Counter 000.
- Stitch Dial **6**, increase 1 stitch at both ends of the next and every following 7th row, 22 times in all, until the Row Counter shows 148.

Fully fashioned increase — page 4

Making up

— Join the left shoulder on the machine, using the yarn end.

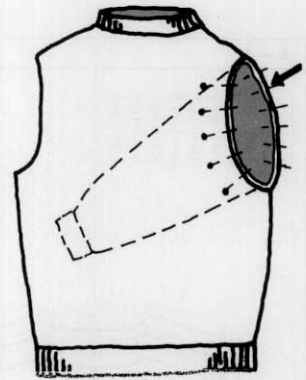
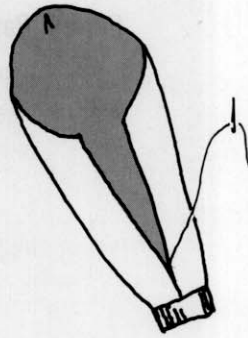
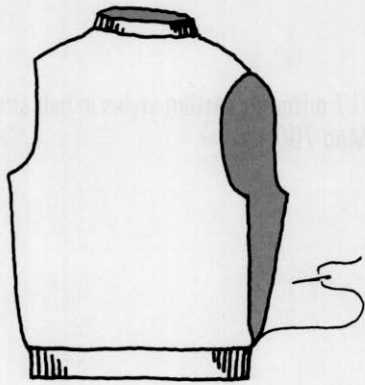

— Join the side, neckband and sleeve seams.

Blind stitch — page 23

— Turn the garment to the wrong side and slip the sleeves into the armhole, with the right side facing each other. Pin them as illustrated and work slip stitch along the edges.

Slip stitch — page 24

— Sew in yarn ends on the wrong side.

Sew in yarn end — page 24

— Give final press.

SELECTING A PATTERN PAPER

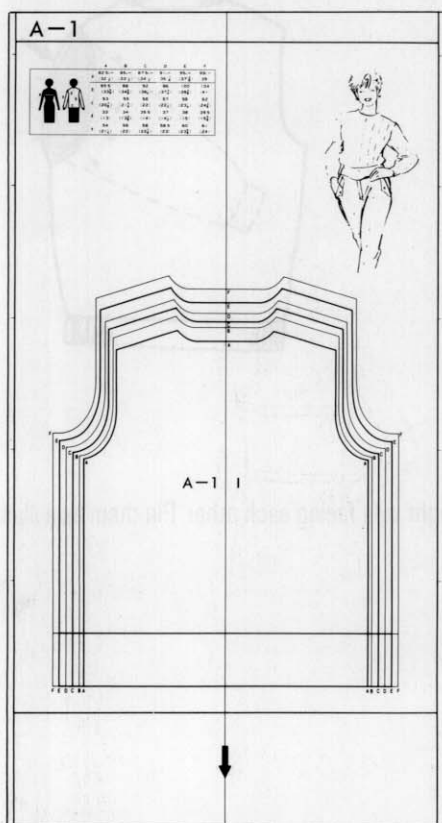

Pattern Paper Set

20 Pattern Papers with 17 different pattern styles in half size are supplied free with the Mod.700 Knitter.

Selecting a pattern style

As a first step to knitting a garment, select a pattern style.

The table below shows the selection.

	Pattern style	Pattern No.	Page No.
Lady's	Pullover	A — 1	1, 2, 3
	Raglan Sleeve Pullover	A — 2	4, 5, 6
	Cardigan	A — 3	7, 8, 9
	French Sleeve Pullover	A — 4	10, 11
	Skirt	A — 5	12
	Slacks	A — 6	13, 14, 15, 16
Man's	Pullover	B — 1	17, 18, 19
	Raglan Sleeve Pullover	B — 2	20, 21, 22
	Saddle Shoulder Cardigan	B — 3	23, 24, 25
	Vest	B — 4	26, 27
*	Girl's Cardigan	C — 1	28, 29, 30
	Boy's Raglan Sleeve Cardigan	C — 2	31, 32, 33
*	Child's Cardigan	C — 3	34, 35
	Dress	C — 4	36, 37
Baby's	Coat	C — 5	38
	Leggings	C — 6	39
	Pants	C — 7	40

**Using these patterns, you can also knit a pullover.*

Selecting a pattern size

Each pattern style is drawn full pattern in half size with 1 — 6 sizes which are lettered A, B, C, D, E and F from the smaller to larger sizes.

Measurement Table shown below as an example gives for each pattern style, and is consists of two sections.

One section (shaded line) shows body measurement and other shows finished measurements of the garment, allowing for ease.

	A	B	C	D	E	F
a	82.5cm (32 ¹ / ₂)	85cm (33 ¹ / ₂)	87.5cm (34 ¹ / ₂)	91cm (35 ⁷ / ₈)	95cm (37 ³ / ₈)	99cm (39")
b	85.5 (33 ⁵ / ₈)	88 (34 ⁵ / ₈)	92 (36 ¹ / ₄)	96 (37 ³ / ₄)	100 (39 ³ / ₈)	104 (41)
c	53 (20 ⁷ / ₈)	55 (21 ⁵ / ₈)	56 (22)	57 (22 ¹ / ₂)	59 (23 ¹ / ₄)	62 (24 ³ / ₈)
d	33 (13)	34 (13 ³ / ₈)	35.5 (14)	37 (14 ¹ / ₂)	38 (15)	39.5 (15 ⁵ / ₈)
e	54 (21 ¹ / ₄)	56 (22)	58 (22 ⁵ / ₈)	58.5 (23)	60 (23 ⁵ / ₈)	61 (24)

Where to take measurements

- ① Bust
Over the fullest part of your bust and around back.
- ② Waist
Around the natural waist curve line.
- ③ Hip
Over the highest part of buttocks.
- ④ Back width
From shoulder bone to shoulder bone.
- ⑤ Length
From the first vertebra to the desired length.
- ⑥ Sleeve length
From shoulder bone to wrist.

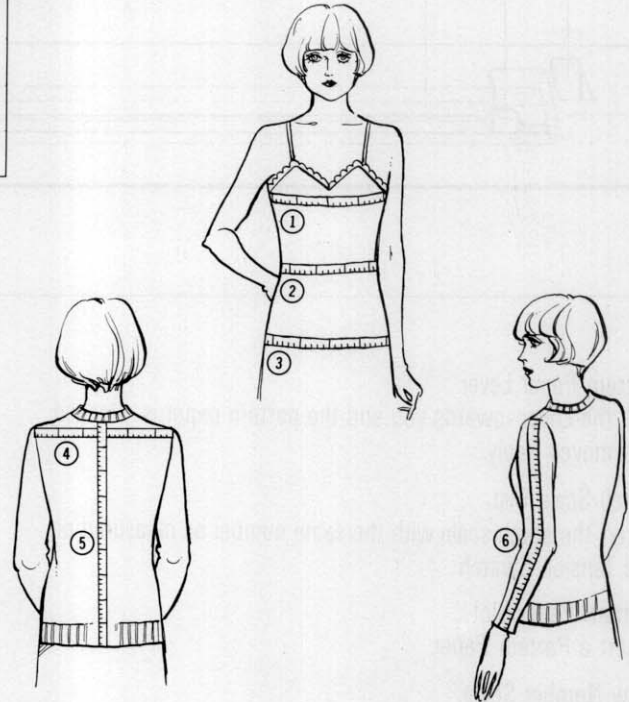

To select your size, take your body measurement at the position indicated by the black figure in Table, and select the size nearest to your requirements.

Example: If your bust measurement is 85cm.(33"1/2), select size B.

Take the measurement of the other parts of your body as listed opposite and check them against the selected pattern size. The pattern measurements include ease.

	A	B	C	D	E	F
a	82.5cm (32 ¹ / ₂)	85cm (33 ¹ / ₂)	87.5cm (34 ¹ / ₂)	91cm (35 ⁷ / ₈)	95cm (37 ³ / ₈)	99cm (39")
b	85.5 (33 ⁵ / ₈)	88 (34 ⁵ / ₈)	92 (36 ¹ / ₄)	96 (37 ³ / ₄)	100 (39 ³ / ₈)	104 (41)
c	53 (20 ⁷ / ₈)	55 (21 ⁵ / ₈)	56 (22)	57 (22 ¹ / ₂)	59 (23 ¹ / ₄)	62 (24 ³ / ₈)
d	33 (13)	34 (13 ³ / ₈)	35.5 (14)	37 (14 ¹ / ₂)	38 (15)	39.5 (15 ⁵ / ₈)
e	54 (21 ¹ / ₄)	56 (22)	58 (22 ⁵ / ₈)	58.5 (23)	60 (23 ⁵ / ₈)	61 (24)

If the body measurements are notably different from the pattern measurements, adjust as shown.

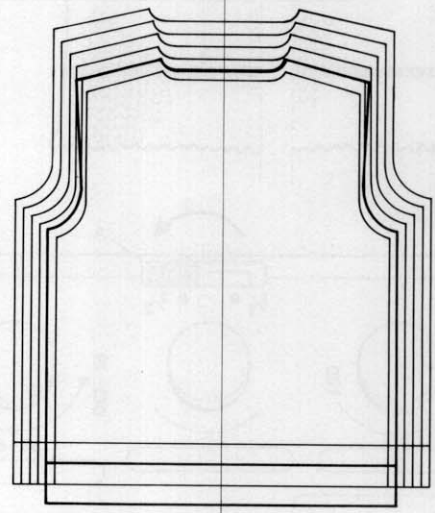

SETTING UP THE KNIT CONTOUR

The Knit Contour tells you where to cast-on/cast off and the number of stitches to be increased/decreased while knitting a garment.

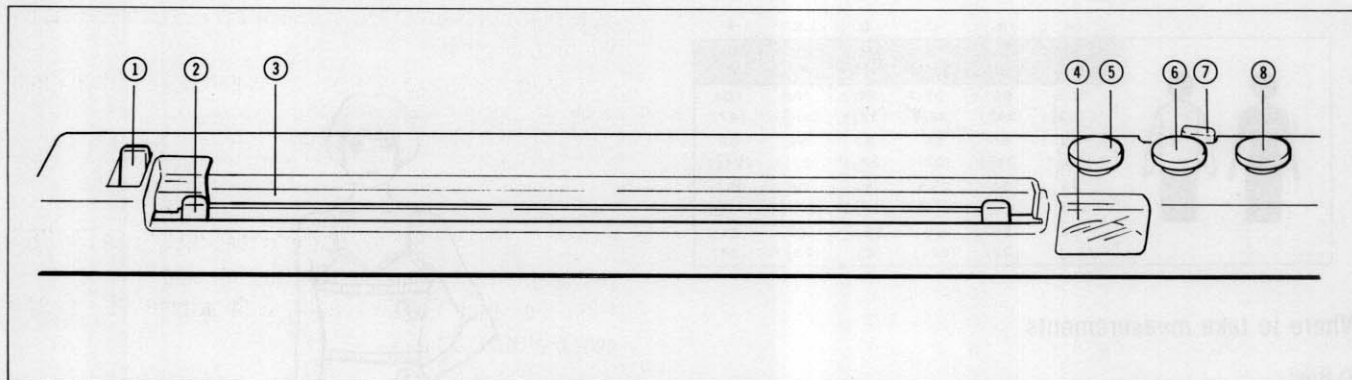

- ① Pattern Paper Lever
Pull the Lever towards you and the pattern paper is released and moves freely.
- ② Stitch Scale Clip.
Insert the stitch scale with the same number as measured on the Tension Switch.
- ③ Pattern Paper Slot.
Insert a Pattern Paper.
- ④ Row Number Scale.
Indicates the number of rows measured over the tension switch.

- ⑤ Row Number Dial.
Select the row number to correspond with the number of rows measured on the tension switch.
- ⑥ Feeding Dial
Move the pattern paper backwards and forwards manually with this dial.
- ⑦ Select Lever
Select the position according to the scale of the pattern.
Half scale pattern — 1/2
Full scale pattern — 1/1
- ⑧ Change Dial
Select the position of 30 — 60 or 61 — 120 according to the row reading from the tension switch. (e.g. if the row reading is 92, select 61 ~ 120.)

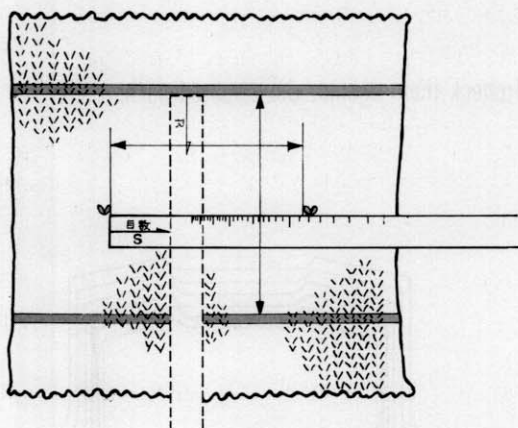

1. Take a tension gauge referring to the pages 1 — 3.

2. Referring to your pattern paper set the Select Lever "A" to either 1/1 or 1/2.
The pattern papers and stitch scales supplied with the knit contour are 1/2 size, so set the Select Lever to 1/2. (If you use 1/1 pattern, see page 53.)

If you have knitted a tension switch as instructed on page 2, set the Select Lever to 1/1.

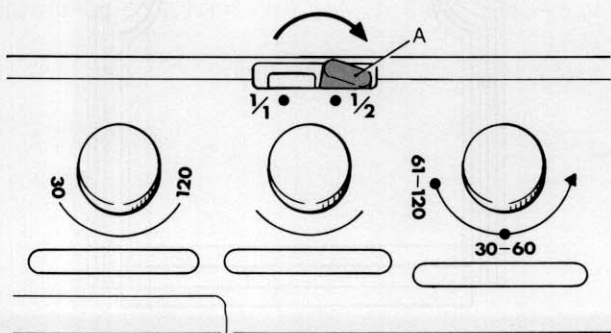

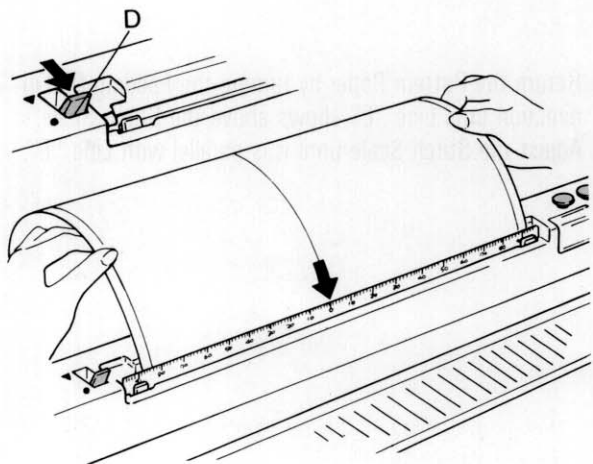
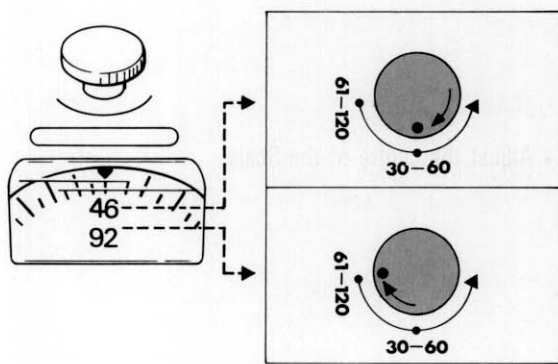
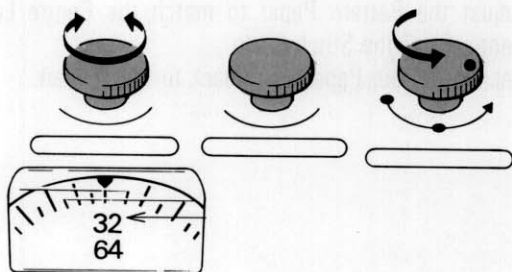
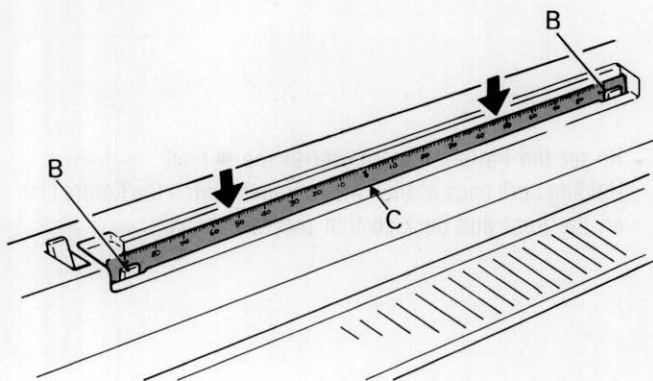
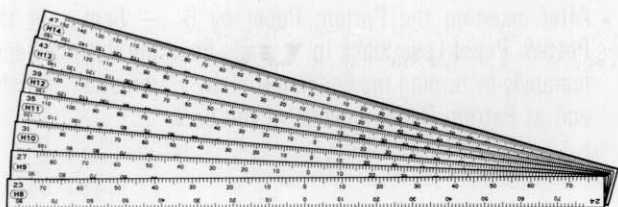

Stitch Scale

A set of 7 Stitch Scales is supplied with the machine. These Scales are numbered H8 to H14 and each of them covers four stitch sizes.

3. Select the Stitch Scale with the same number as measured on the tension square.
(e.g., if the number of stitches measured was 32, the Stitch Scale with 32 at the left should be used.)



4. Insert the selected Stitch Scale into the Stitch Scale Clip "B" so that the correct number is at the left side. Align the Stitch Scale centre (O) with ▲ mark "C" on the centre of Knit Contour.

5. Set the Row number.

Important:

Be sure to set the Change Dial to ◀ when altering the Row Number.

Turn the Row Number Dial until it shows the same number as measured on the tension switch. Align the number with the red pointer in the Row Number Window.

If the Row Number is less than the lowest limit (30 rows), select a number twice the row number read on the tension switch.

(e.g., if 23 row is read on the tension switch, select 46 on the row number scale of the attachment.) And set the Select Lever to 1/1.

6. Set the Change Dial.

*When the row number measured is less than 60, set the Change Dial to 30 — 60, and read from the top set of number in the row number window.

*When the row number is more than 60, set the Change Dial to 61 — 120, and read from the lower set of numbers in the row number window.

7. Set the Pattern Paper.

- Set the Pattern Paper Lever "D" to the ● mark. (the Pattern Paper Holder is opened.)
- Insert the selected Pattern Paper into the Pattern Paper Slot, in the arrowed direction.

*In case of difficulty inserting the Pattern Paper, remove the Stitch Scale from the Clip. Replace the stitch scale after inserting the pattern paper.

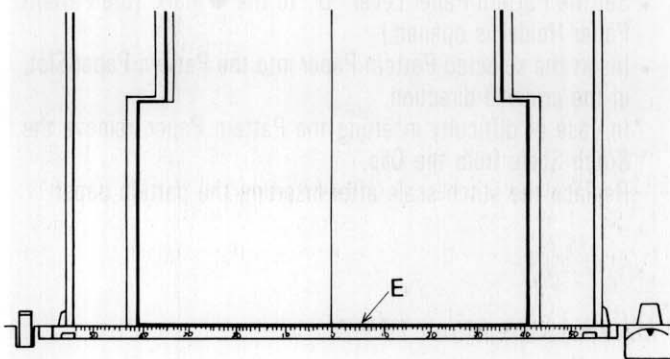
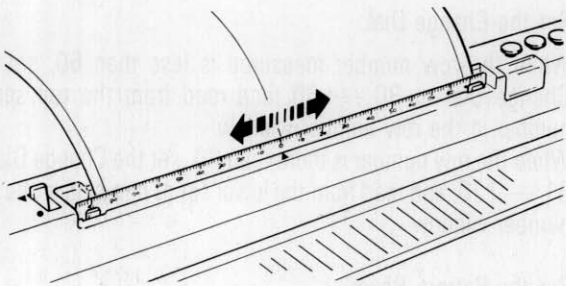
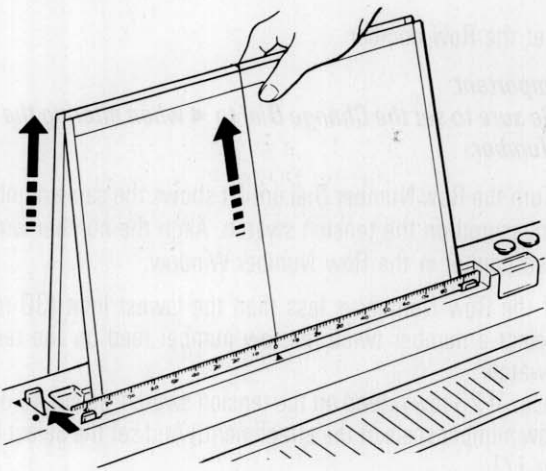
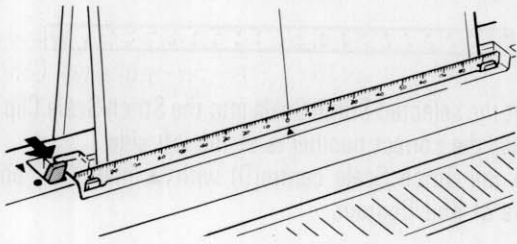
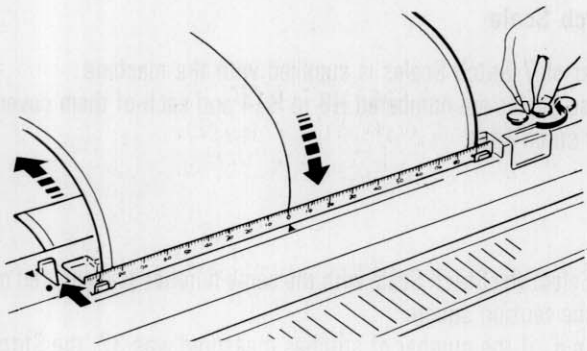

- After inserting the Pattern Paper by 5 — 6cm., set the Pattern Paper Lever back to ▼ mark. Feed the Pattern Paper manually by turning the Feeding Dial to "F" direction until the end of Pattern Paper appears at the back.

- Re-set the Pattern Paper Lever to the ● mark. Holding both ends of the Pattern Paper, match the Centre Line on the front and back so that they are straight.

- Adjust the Pattern Paper to match the Centre Line with Centre(O) of the Stitch Scale. Set the Pattern Paper Lever back to the ▼ mark.

- Adjust the centre of the Scale.

- Return the Pattern Paper by turning the Feeding Dial in "R" direction until Line "E" shows above the Stitch Scale. Adjust the Stitch Scale until it is parallel with Line "E".

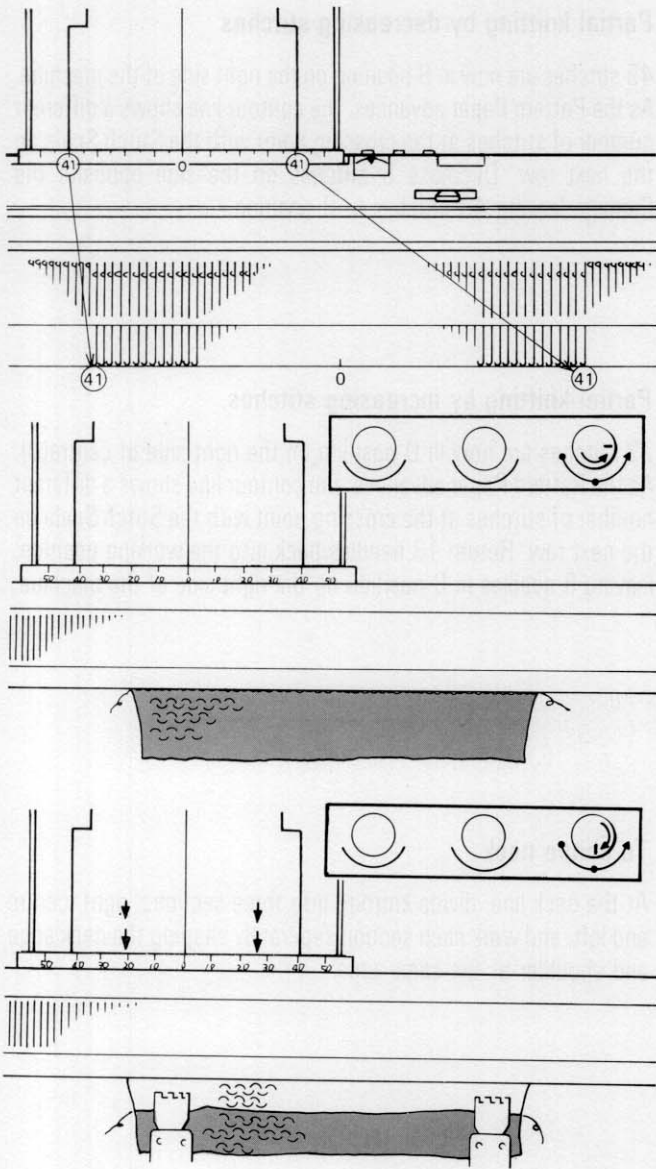

7. How to Read the Contour Line.

- Read the number of stitches shown where the contour line crosses the Stitch Scale.
(If the crossing point of the contour line comes between scales, read the larger number on the Stitch Scale.)
- Arrange the number of stitches read on the Stitch Scale on both sides of the centre(0) of the Knitter.
- Set the Change Dial to ◀ to stop the pattern paper moving. Cast-on with waste yarn and knit 1 row with Ravel Cord.

- Re-set the Change Dial, knit with main yarn. Knitting 1 row moves the Pattern Paper 1 row. Knit vertical contour line without shaping.

Basic techniques required by the contour line are shown below.

Decrease

61 stitches are now on the right side of the machine. As the pattern paper moves, the contour line shows a different number of stitches at the crossing point with the Stitch Scale. Decrease 6 stitches leaving 55 stitches on the machine.

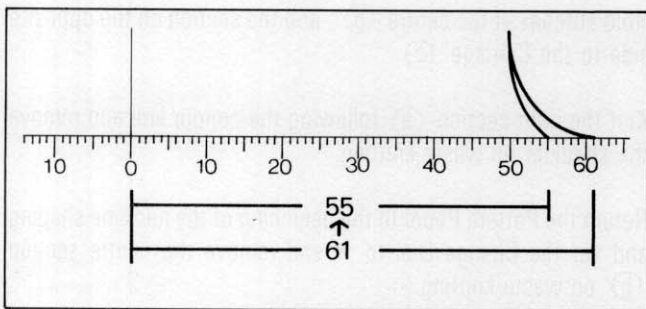

Increase

35 stitches are now on the left side of the machine. As the Pattern Paper advances, the contour line shows a different number of stitches at the crossing point with the Stitch Scale. Increase 1 stitch, making 36 stitches on the machine.

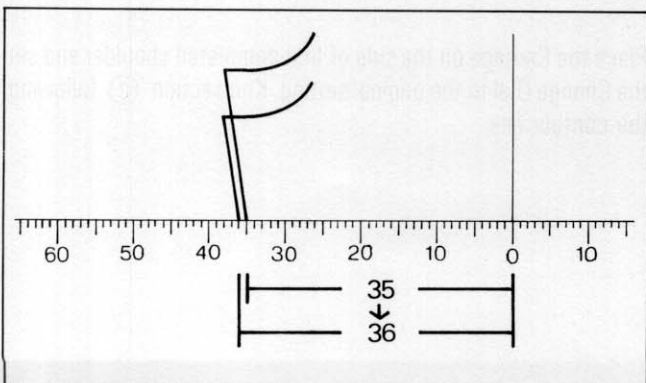

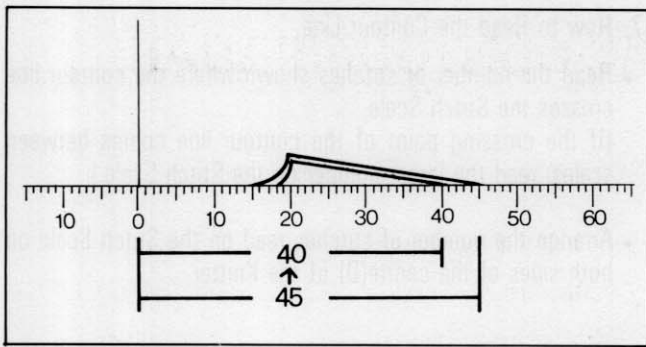

Partial knitting by decreasing stitches

45 stitches are now in B position on the right side of the machine. As the Pattern Paper advances, the contour line shows a different number of stitches at the crossing point with the Stitch Scale on the next row. Decrease 5 stitches on the side opposite the Carriage leaving 40 stitches in B position.

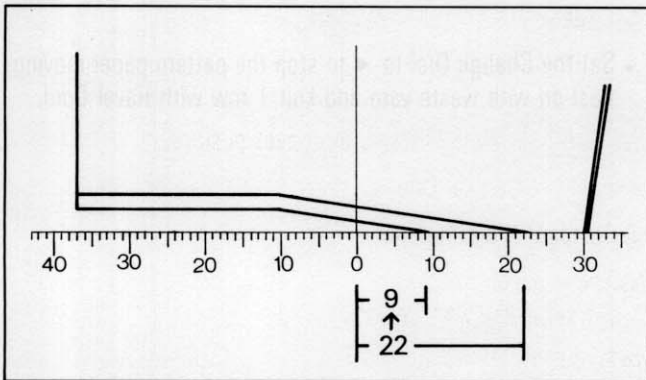

Partial knitting by increasing stitches.

22 stitches are now in D position on the right side of centre(0). As the Pattern Paper advances, the contour line shows a different number of stitches at the crossing point with the Stitch Scale on the next row. Return 13 needles back into the working position, leaving 9 needles in D position on the right side of the machine.

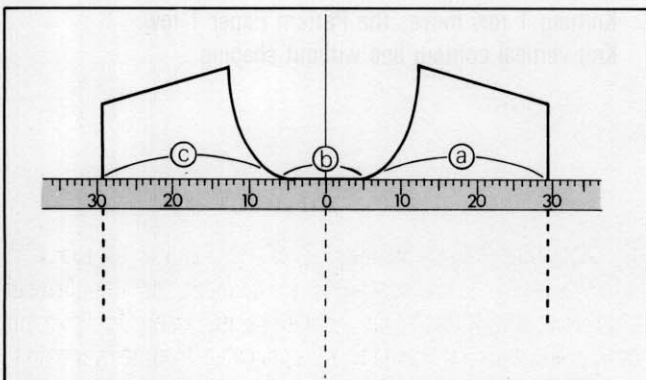

To shape neck

At the neck line, divide knitting into three sections; right, centre and left, and work each section separately shaping the neck edge and shoulder at the same time.

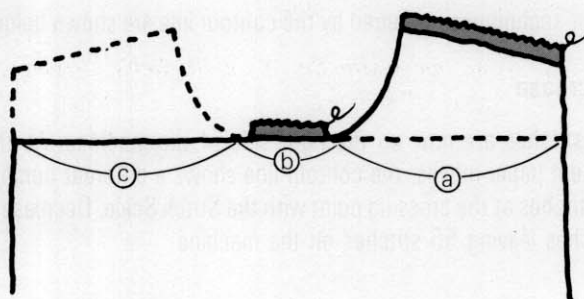

Hold stitches at the centre (b), and the section on the opposite side to the Carriage (c).

Knit the right section (a) following the contour line and remove the shoulder on waste knitting.

Return the Pattern Paper to the beginning of the neckline shaping and set the Change Dial to ◀ and remove the centre section (b) on waste knitting.

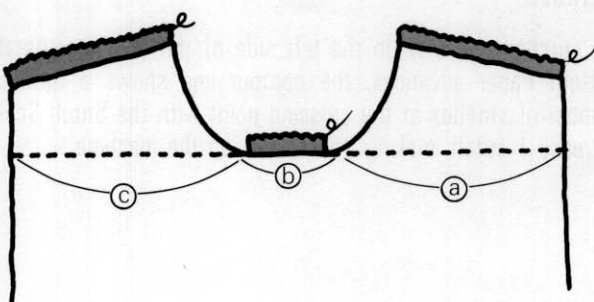

Place the Carriage on the side of first completed shoulder and set the Change Dial to the original setting. Knit section (c) following the contour line.

KNITTING USING THE KNIT CONTOUR(RADAR)

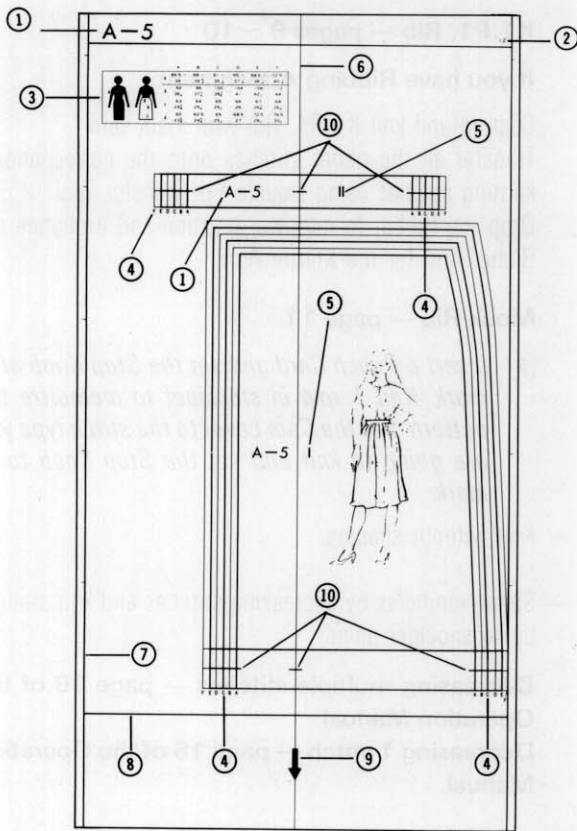

Information given on each Pattern Paper.

- ① Pattern style number
- ② Pattern Paper number
- ③ Measurement Table
- ④ Pattern size
- ⑤ Pattern piece number
- ⑥ Centre Line
(To set the Pattern Paper in correct position)
- ⑦ Standard Vertical Line
- ⑧ Standard Horizontal Line
- ⑨ Arrow mark
(To set in the Knit Contour)
- ⑩ Fold line

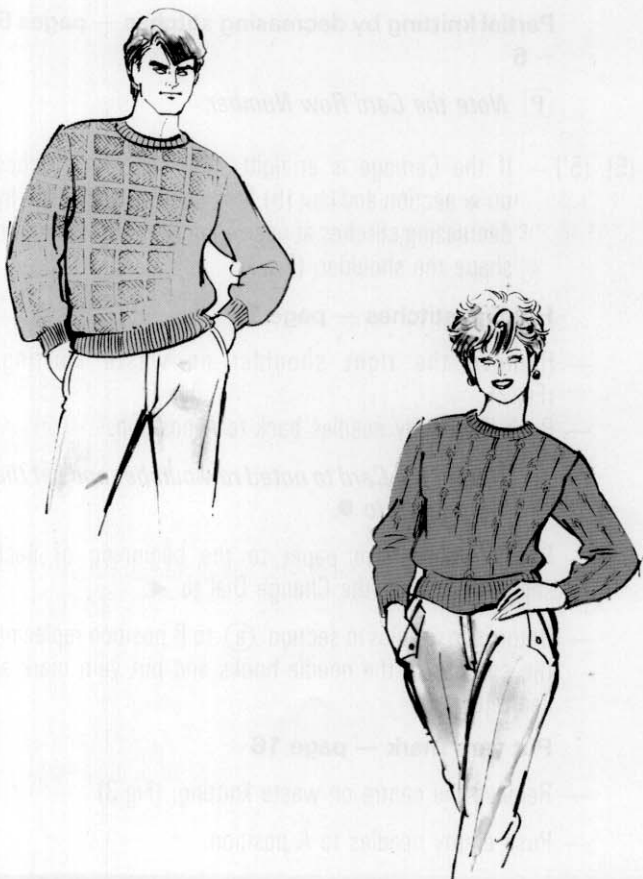

It is advisable to knit the Lady's or Man's Pullover as a first try before knitting the other types of garment, as the pullover requires most of the basic techniques necessary for garment making and these techniques are applicable to other garments.

Knit pullover following the instructions.

*The instructions given after the **P** mark should be followed when a Punch Card is in use.*

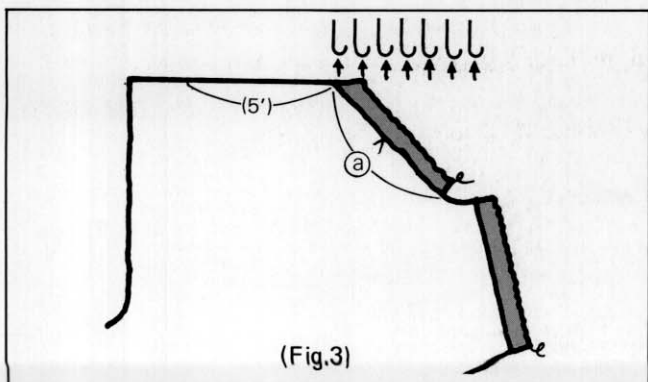
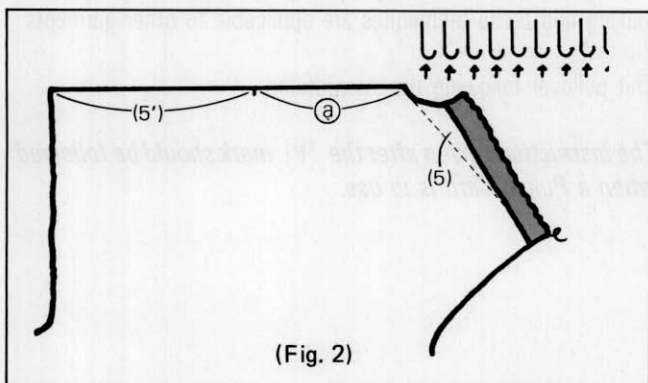
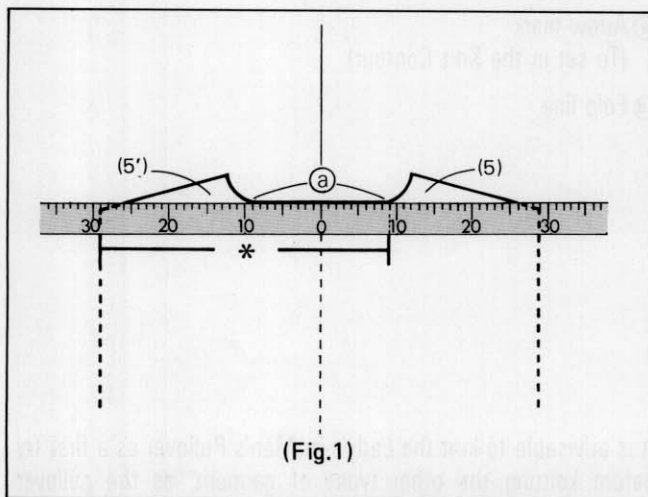
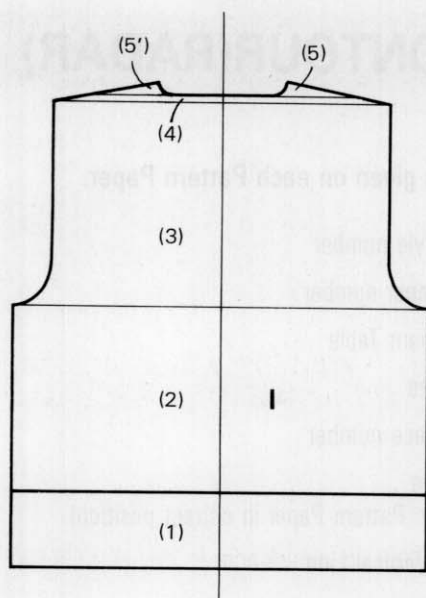

BACK

Set the pattern paper for back.

- (1) — Cast-on and knit K1.P1. Rib for welt.

K1.P1. Rib — pages 9 ~ 10

If you have Ribbing Attachment...

Cast-on and knit K1.P1. Rib with main yarn. Transfer all the ribber stitches onto the corresponding knitting needles using Double Eye Transfer Tool. Drop the Ribber to its lower position and exchange the Ribber Arm for the Knitter Arm.

Mock Rib — page 11

- P** Insert a Punch Card and set the Stop Knob at ● mark. Knit 1 row in stockinet to memorize the pattern. Set the Cam Lever to the stitch type you are going to knit and set the Stop Knob to ▼ mark.

- (2) — Knit without shaping.
 (3) — Shape armholes by decreasing stitches and knit straight up to shoulder point.

Decreasing multiple stitches — page 16 of the Operation Manual

Decreasing 1 stitch — page 16 of the Operation Manual.

- (4) — Shape shoulders decreasing by partial knitting up to neck edge.

Partial knitting by decreasing stitches — pages 5 ~ 6

- P** Note the Card Row Number.

- (5), (5') — If the Carriage is at right side, hold the stitches on * section and knit (5) first, shaping neck edge by decreasing stitches at neck edge while continuing to shape the shoulder. (Fig.1)

Holding stitches — page 14

- Remove the right shoulder on waste knitting. (Fig.2)
- Push the empty needles back to A position.

- P** Return the Card to noted row number and set the Stop Knob to ●.

- Return the pattern paper to the beginning of neck shpaping and set the Change Dial to ◀.
- Return the needles in section (a) to B position replacing the stitches in the needle hooks and put yarn mark at centre(0).

Put yarn mark — page 16

- Remove the centre on waste knitting. (Fig.3)
- Push empty needles to A position.

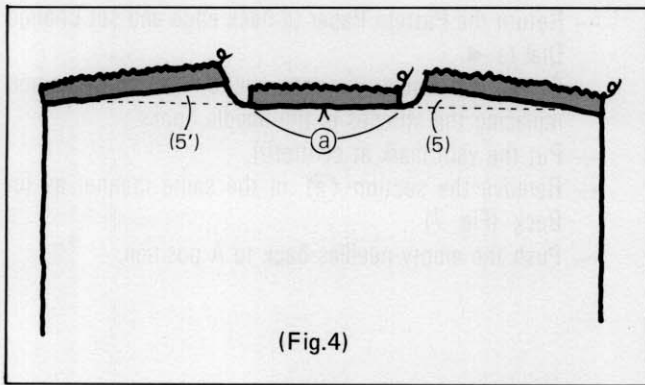

- Move the carriage to the right side of the knitting.
- P** *Set the Stop Knob to ▼ and Cam Lever to the stitch type of main knitting.*
- Set Change Dial to the original setting.
- Knit (5') in the same way as for (5).
- Remove the left shoulder on waste knitting. (Fig. 4)
- * If the Carriage is at left side, at the beginning of the neck shaping, knit (5') first.

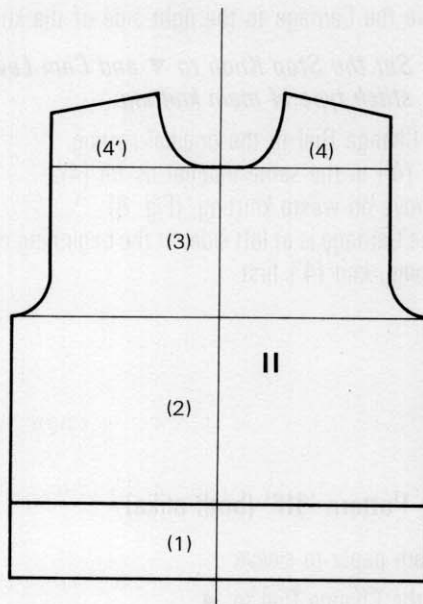

FRONT — Pattern "II"

Set the pattern paper for front.

(1) — (3) — Knit up to neck edge in the same way as for Back.

P *Note the Card Row Number.*

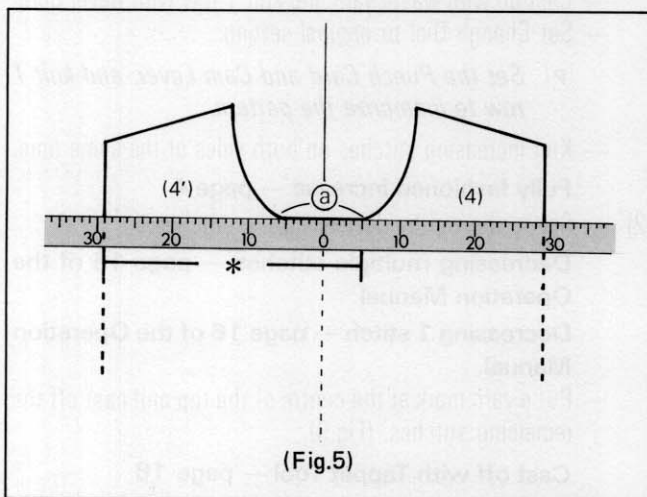

(4), (4') — If the Carriage is at right side, hold the stitches on * section and knit (4) first shaping neck edge by decreasing stitches and shaping shoulder by partial knitting. (Fig. 5)

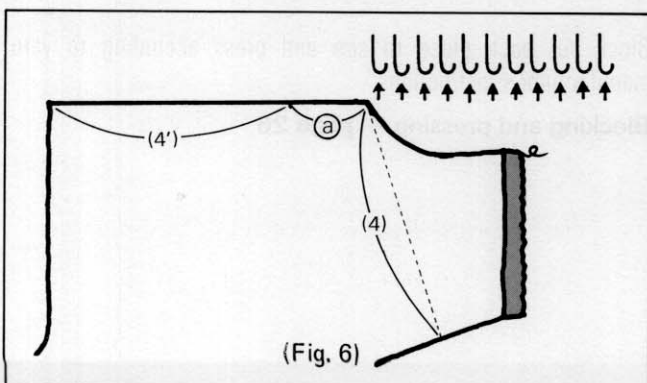

- Remove the right shoulder on waste knitting. (Fig. 6)
- Push the empty needles back to A position.
- P** *Return the Card to the noted card row number and set Stop Knob to ●.*

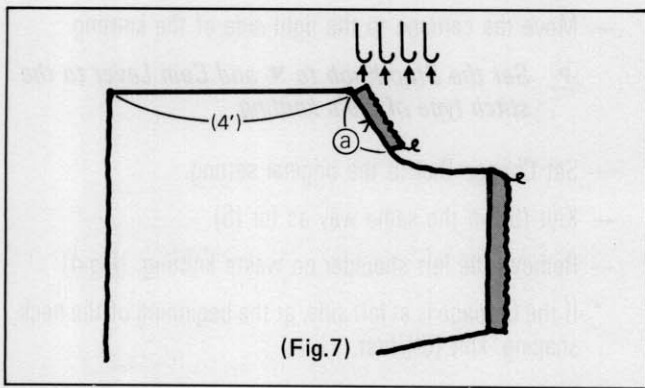

- Return the Pattern Paper to neck edge and set Change Dial to ◀.
- Return the needles in centre section (a) to B position replacing the stitches in the needle hooks.
- Put the yarn mark at centre(0).
- Remove the section (a) in the same manner as for Back. (Fig. 7)
- Push the empty needles back to A position.

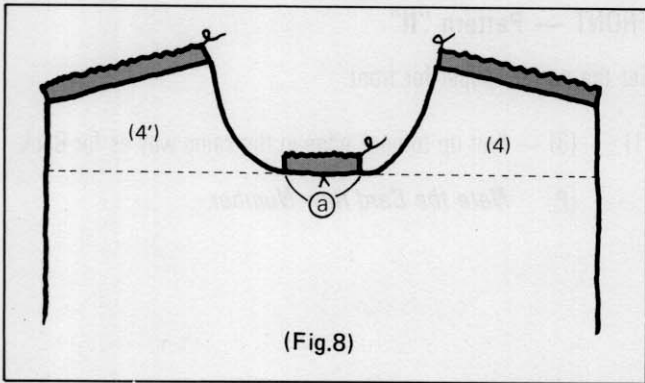

- Move the Carriage to the right side of the knitting.
- P** *Set the Stop Knob to ▼ and Cam Lever to the stitch type of main knitting.*
- Set Change Dial to the original setting.
- Knit (4') in the same manner as for (4).
- Remove on waste knitting. (Fig. 8)
- * If the Carriage is at left side, at the beginning of the neck shaping, knit (4') first.

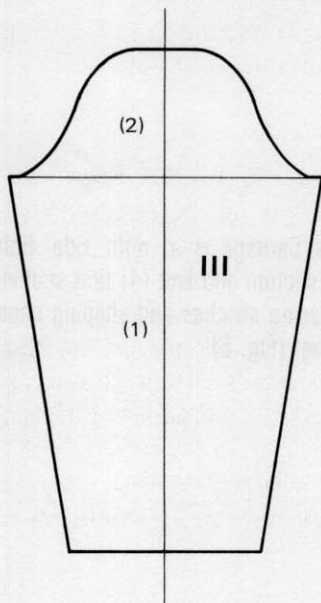

SLEEVE — Pattern "III" (both alike)

Set the pattern paper to sleeve.

- (1) — Set the Change Dial to ◀.
 - Cast-on with waste yarn and knit 1 row with Ravel Cord.
 - Set Change Dial to original setting.
 - P** *Set the Punch Card and Cam Lever, and knit 1 row to memorize the pattern.*
 - Knit increasing stitches on both sides at the same time.

Fully fashioned increase — page 4
- (2) — Shape the top by decreasing the stitches.
 - Decreasing multiple stitches — page 16 of the Operation Manual**
 - Decreasing 1 stitch — page 16 of the Operation Manual.**
 - Put a yarn mark at the centre of the top and cast off the remaining stitches. (Fig.9)
 - Cast off with Tappet Tool — page 18**

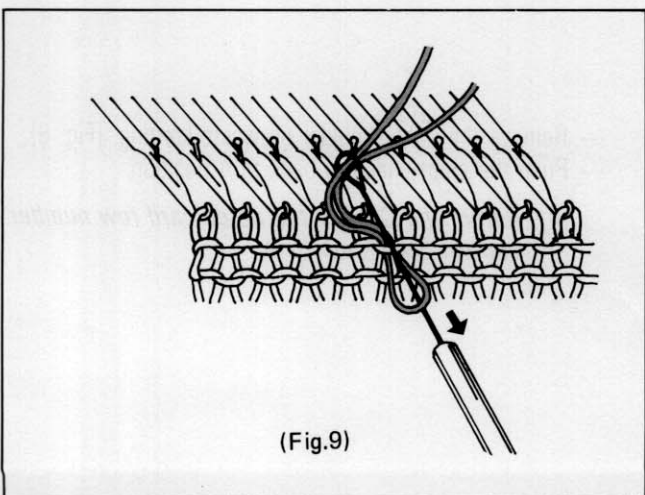

Block out each piece to size and press according to yarn manufacturer's instructions.

Blocking and pressing — page 26

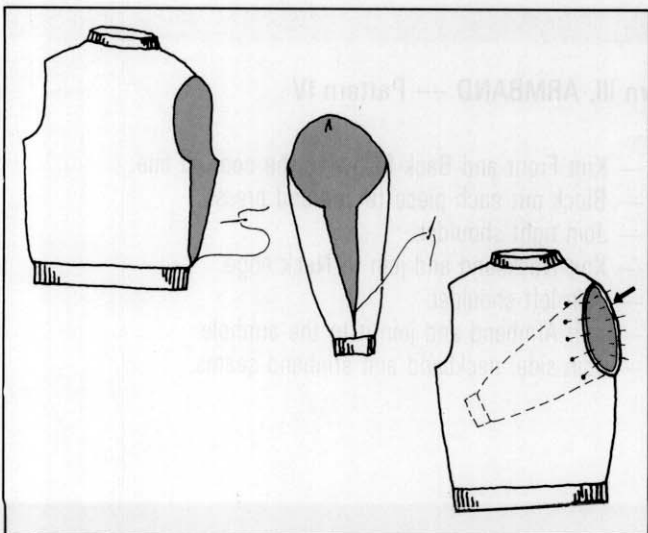
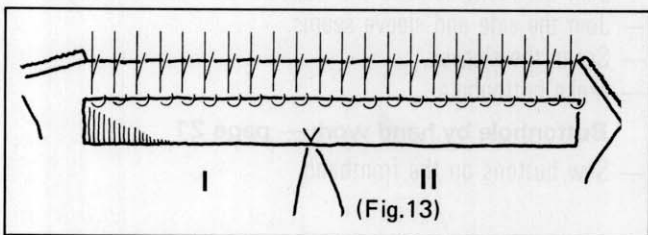
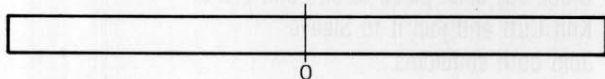
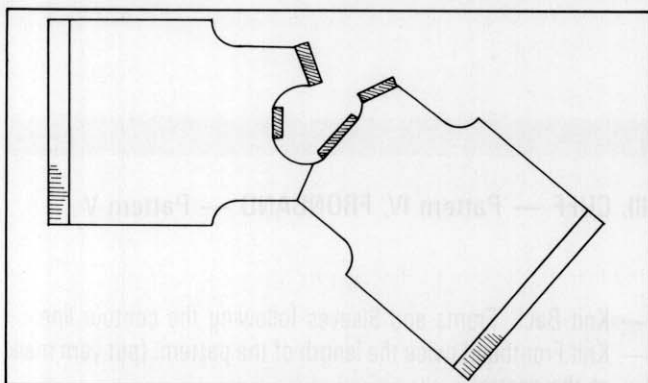
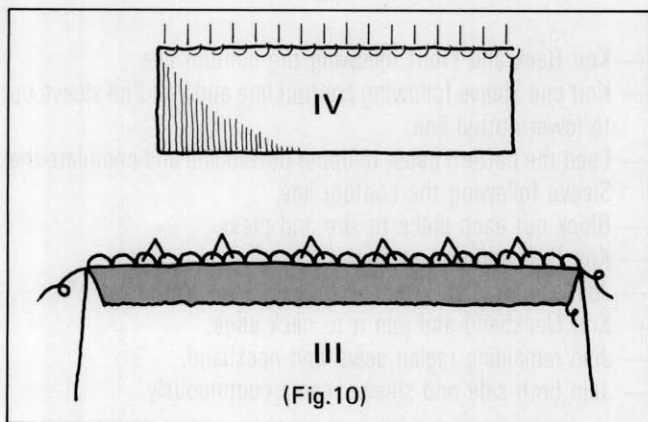
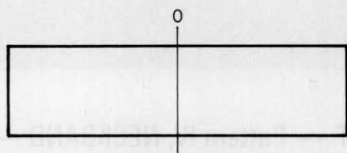

CUFF — Pattern "IV" (both alike)

Set the pattern paper for Cuff.

— Cast-on and knit K1.P1. Rib without shaping.

Join the Cuff to the Sleeve

— With Wrong side facing you, pick up the stitches on the first main row of the Sleeve, gathering sleeve stitches evenly and place them on the same needles. (Fig.10)

— Knit 1 row and cast off with back stitch method.

Joining on the machine, stitch to stitch — page 21

NECKBAND — Pattern "V"

— Join the right shoulder.

Joining on the machine, stitch to stitch — page 21

— Set the pattern paper for the Neckband.

— Knit K1.P1. Rib without shaping.

— Remove the neckband on waste knitting and leave the empty needles in B position.

Join the Neckband to the neck edge.

— Pick up the stitches from the neck edge evenly on the empty needles of Neckband with the right side facing you and place them onto the same needles.

— Push these needles to D position.

— Pick up the stitches from the last row in main knitting of Neckband and place them onto the same needle hooks.

— Push the needles from D position back to B position. The stitches behind the latches will slip off the needles.

— Cast off using back stitch method.

Joining on the machine, open stitches to side edge — page 22

MAKING UP

— Join the left shoulder the same way as for right one.

— Join side, neckband and sleeve seams.

Blind stitch — page 23

— Turn garment to the wrong side and place the sleeves into the armhole. Pin them and work slip stitch along the edge.

Slip stitch — page 24

— Sew in yarn ends on the wrong side.

Sew in yarn ends — page 24

— Give a final press.

A — 2 LADY'S RAGLAN SLEEVE PULLOVER
B — 2 MAN'S RAGLAN SLEEVE PULLOVER

BACK — Pattern I, FRONT — Pattern II, SLEEVE [L] & [R] — Pattern III, CUFF — Pattern IV, NECKBAND — Pattern V

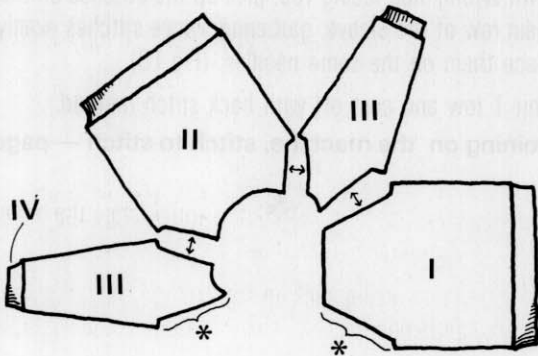

- Knit Back and Front following the contour line.
- Knit one Sleeve following contour line and knit 2nd sleeve up to lower dotted line.
- Feed the pattern paper to upper dotted line and complete the Sleeve following the contour line.
- Block out each piece to size and press.
- Knit Cuff and join to Sleeve.
- Join three raglan seams except for back left raglan (*).
- Knit Neckband and join it to neck edge.
- Join remaining raglan seam and neckband.
- Join both side and sleeve seams continuously.

A — 3 LADY'S CARDIGAN

BACK — Pattern I, FRONTS — Pattern II, SLEEVE — Pattern III, CUFF — Pattern IV, FRONBAND — Pattern V

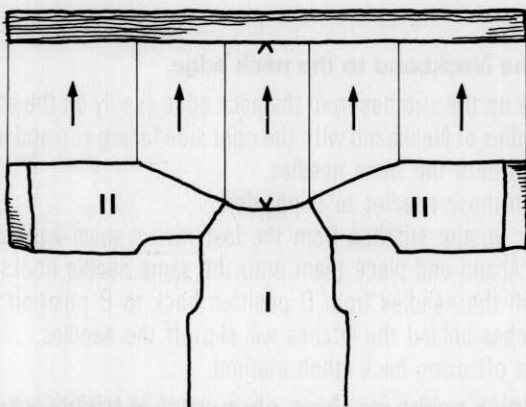

- Knit Back, Fronts and Sleeves following the contour line.
 - Knit Frontband twice the length of the pattern. (put yarn mark at the centre)
 - Block out each piece to size and press.
 - Knit Cuff and join it to Sleeve.
 - Join both shoulders.
 - Join the Front band to the front centre and neck edge.
 - Join the side and sleeve seams.
 - Set in the sleeves.
 - Make buttonhole.
- Buttonhole by hand work — page 21**
- Sew buttons on the frontband.

A — 4 LADY'S FRENCH SLEEVE PULLOVER

BACK — Pattern I, FRONT — Pattern II, NECKBAND — Pattern III, ARMBAND — Pattern IV

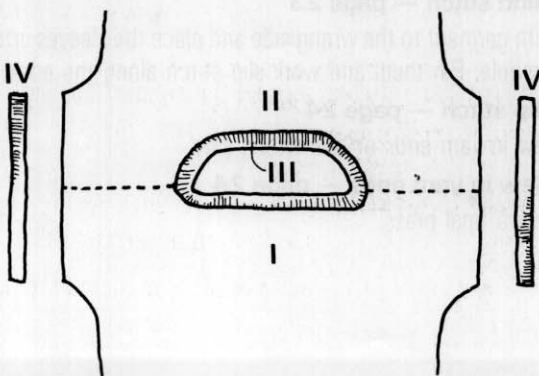

- Knit Front and Back following the contour line.
- Block out each piece to size and press.
- Join right shoulder.
- Knit Neckband and join to Neck edge.
- Join left shoulder.
- Knit Armband and join it to the armhole.
- Join side, neckband and armband seams.

A — 5 LADY'S SKIRT

PANEL — Pattern I, WAISTBAND — Pattern II

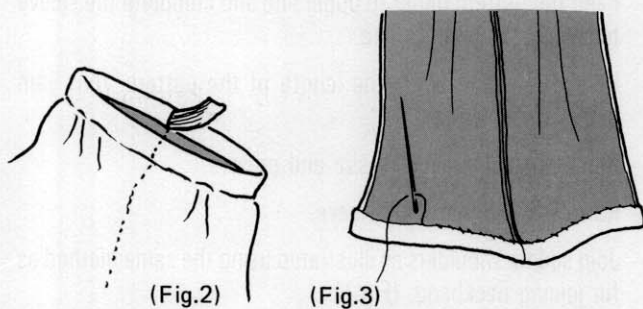
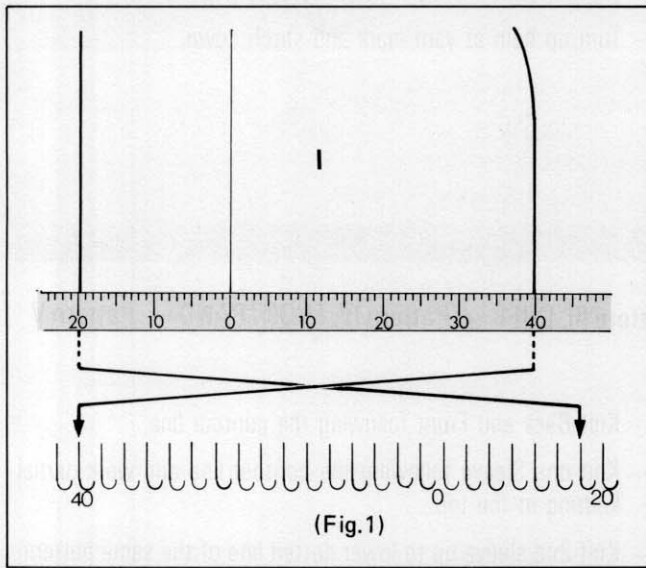

— Cast-on and knit 2 panels following contour line. (Put yarn marks at folding position.)

Cast-on by winding yarn — page 12

- Knit another 2 panels following the same manner, but reverse the shaping. (Fig. 1)
- Block out each piece to size and press.
- Join centre seams of front and back.
- Set the pattern paper for Waistband and arrange the required number of needles in B position.
- With wrong side facing, pick up stitches from last main row of 2 panels, gathering stitches evenly, and knit Waistband.
- Pick up the stitches from the first row of waistband and place on the corresponding needles.
- Knit 1 row and cast off using back stitch method or using Tappet Tool.
- Knit second half of Waistband in the same manner as for first half.
- Join side seams leaving an opening in the waistband for the elastic.
- Insert elastic through the waistband. (Fig. 2)
- Turn up hem at the yarn mark. (Fig. 3)

A — 6 LADY'S SLACKS

BACK [L] & [R] — Pattern I, FRONT [L] & [R] — Pattern II, WAISTBAND (back) — Pattern III, WAISTBAND (front) — Pattern IV

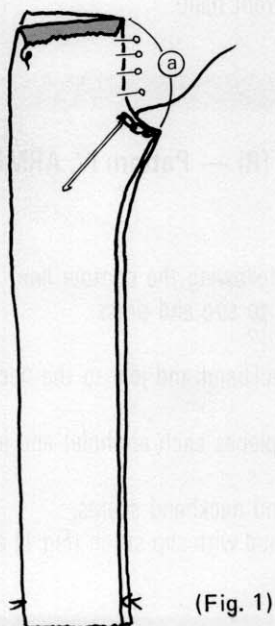

— Cast-on and knit Backs [L] & [R] and Fronts [L] & [R] following the contour line. (Place yarn marks at folding position.)

Cast-on by winding method — page 12

- Block out each piece to size and press.
- Join the centre front and back seams (a). (Fig. 1)
- Set the pattern paper for Waistband (back) and arrange required number of needles.
- With wrong side facing, pick up the stitches from the last main row of the back and place them on the needles gathering evenly.
- Knit Waistband and pick up the stitches from the first row of the waistband and place on the corresponding needles.
- Knit 1 row and cast off using back stitch method or using Tappet Tool.

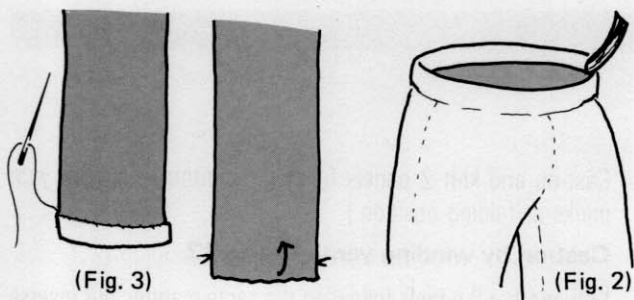

- Knit Waistband (front) in the same manner as for back.
- Join side seams leaving an opening for elastic in the waistband.
- Insert elastic through the waistband. (Fig. 2)
- Turn up hem at yarn mark and stitch down.

B — 3 MAN'S SADDLE SHOULDER CARDIGAN

BACK — Pattern I, FRONTS — Pattern II, SLEEVE [L] & [R] — Pattern III, CUFF — Pattern IV, FRONTBAND — Pattern V

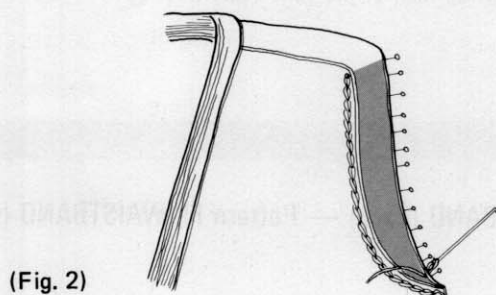
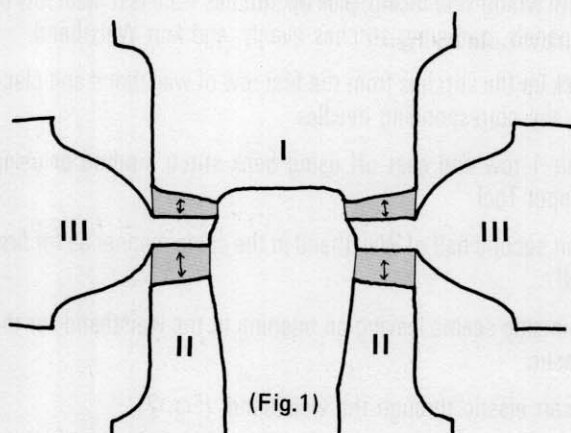

- Knit Back and Front following the contour line.
- Knit one Sleeve following the contour line and work partial knitting at the top.
- Knit 2nd sleeve up to lower dotted line of the same pattern.
- Feed the pattern paper to upper line and complete the sleeve following the contour line.
- Knit Front band twice the length of the pattern. (put yarn mark at the centre)
- Block out each piece to size and press.
- Knit Cuff and join it to Sleeve.
- Join saddle shoulders as illustrated using the same method as for joining neckband. (Fig.1)
- Join the Front band to the front centre and neck edge.
- Join the side and sleeve seams.
- Set in the sleeves. (Fig.2)
- Make buttonholes on the front band.
- Sew buttons on the front band.

Buttonhole by hand work — page 21

B — 4 MAN'S VEST

BACK — Pattern I, FRONT — Pattern II, NECKBAND [L] — Pattern III, NECKBAND [R] — Pattern IV, ARMBAND — Pattern V

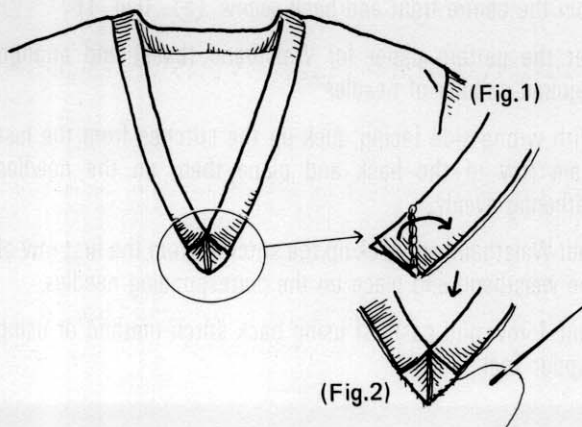

- Knit Back and Front following the contour line.
- Block out each piece to size and press.
- Join right shoulder.
- Knit left and right Neckband and join to the neck edge.
- Join left shoulder.
- Knit Armbands (two pieces each armhole) and join them to armholes.
- Join side, armband and neckband seams.
- Join centre of neckband with slip stitch (Fig.1) and stitch it down (Fig.2).

C — 1 GIRL'S CARDIGAN
C — 3 CHILD'S CARDIGAN

BACK — Pattern I, FRONTS — Pattern II, SLEEVE — Pattern III, CUFF — Pattern IV, NECKBAND — Pattern V, FRONTBAND — Pattern VI

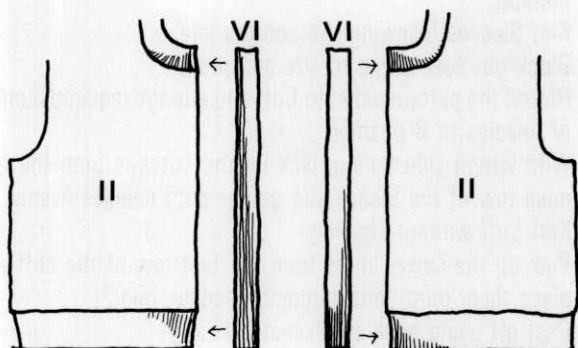

- Knit Back, Fronts and Sleeves Following the contour line.
- Knit two pieces of Front band.
- Block out each piece to size and press.
- Knit Cuff and join it to Sleeve.
- Join both shoulder.
- Knit Neckband and join to neck edge.
- Join Front bands to front edges.
- Join side and sleeve seams.
- Set in Sleeves.
- Make buttonholes on the Frontband.

Buttonhole by hand work — page 21

- Sew buttons on the frontband.

C — 2 BOY'S RAGLAN SLEEVE CARDIGAN

BACK — Pattern I, FRONTS — Pattern II, SLEEVE [L] & [R] — Pattern III, CUFF — Pattern IV, FRONTBAND — Pattern V

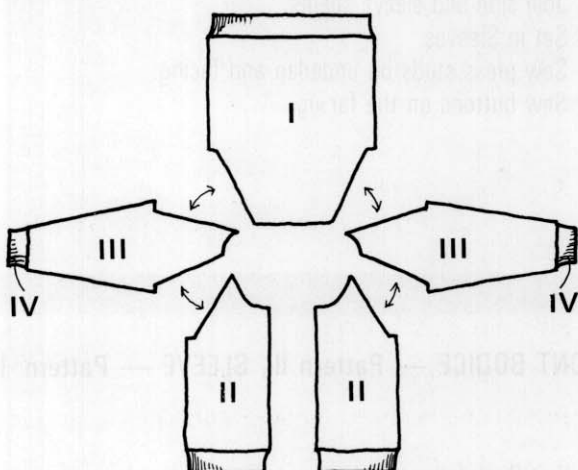

- Knit Back and Fronts following the contour line.
- Knit one Sleeve following the contour line and knit 2nd Sleeve up to lower dotted line with the same pattern.
- Feed the pattern paper to upper line and complete the Sleeve following the contour line.
- Knit Front band twice the length of the pattern. (put yarn mark at the centre.)
- Block out each piece to size and press.
- Knit Cuff and join it to the Sleeve.
- Join four raglan seams.
- Join Front band to the front and neck edge.
- Join both side and sleeve seams.
- Make buttonholes on the frontband.

Buttonhole by hand work — page 21

- Sew buttons on the frontband.

C — 4 CHILD'S DRESS

SKIRT — Pattern I, BACK BODICE — Pattern II, FRONT BODICE — Pattern III, SLEEVE — Pattern IV or IV' (puff sleeve), CUFF — Pattern V or V', NECKBAND — Pattern VI

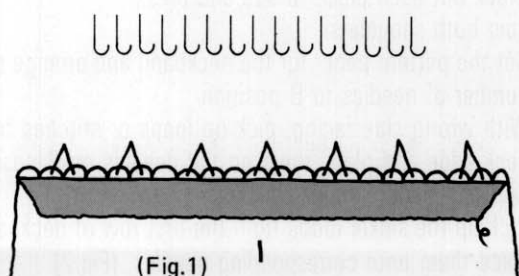

- Knit Back Skirt following the contour line with doubled hem and remove it on waste knitting.
- Set the pattern paper for Back Bodice and arrange required number of needles to B position.
- With wrong side facing, pick up the stitches from the last row of the skirt and place them on the needles gathering evenly. (Fig.1)

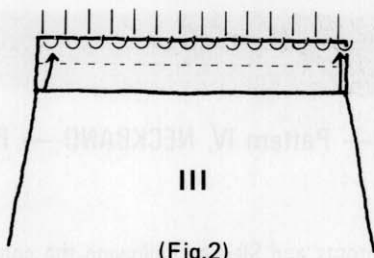

(Fig.2)

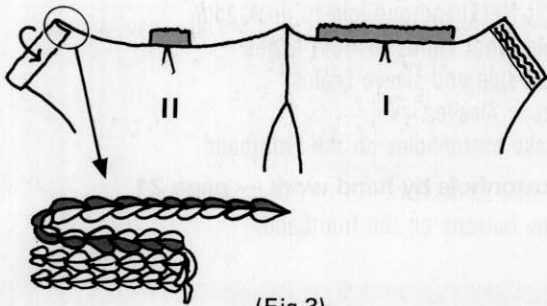
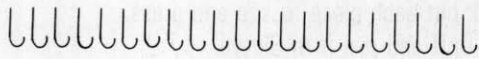

(Fig.3)

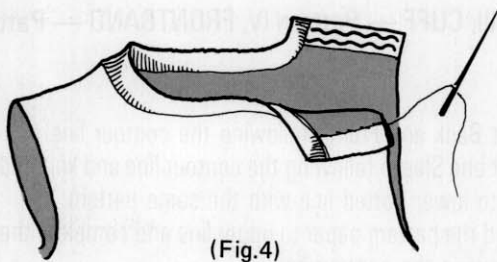

(Fig.4)

- Knit Back Bodice up to neck.
- Knit underlap in garter stitch.

Garter stitch — page 26

- Cast off using back stitch method.
- Knit Front Skirt and Bodice up to neck point.
- Knit facing in stockinet and cast off using back stitch method.
- Knit Sleeves following the contour line.
- Block out each piece to size and press.
- Return the pattern paper to Cuff and arrange required number of needles to B position.
- With wrong side facing, pick up the stitches from the first main row of the Sleeve and gather onto needles evenly.
- Knit Cuff without shaping.
- Pick up the sinker loops from the first row of the cuff and place them onto corresponding needles. (Fig.2)
- Cast off using back stitch method.
- Join the right shoulder.
- Set the pattern paper for the neckband and arrange the required number of needles in B position.
- With wrong side facing, pick up the stitches from the neck, underlap and half stitches of folded facing, and place them onto needles in B position. (Fig.3)
- Knit neckband in the same way as for cuff.
- Fold the facing inside and stitch it down. (Fig.4)
- Join side and sleeve seams.
- Set in Sleeves.
- Sew press studs on underlap and facing.
- Sew buttons on the facing.

C — 5 BABY'S COAT

FRONT & BACK — Pattern I, BACK BODICE — Pattern II, FRONT BODICE — Pattern III, SLEEVE — Pattern IV, NECKBAND — Pattern V, FRONTBAND — Pattern VI

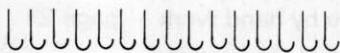

(Fig.1)

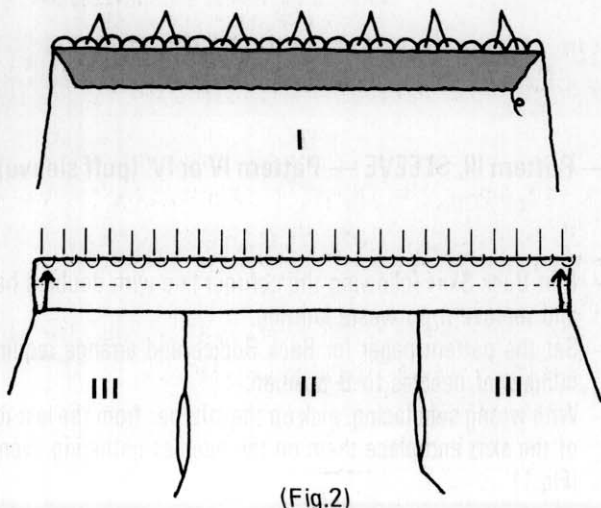

(Fig.2)

- Knit Back following contour line with picot hem and remove on waste knitting.

Picot hem — page 13

- Set the pattern paper for Back Bodice and arrange required number of needles to B position.
- With wrong side facing, pick up the stitches from the last main row of Back and gather onto needles evenly. (Fig.1)
- Knit Back Bodice.
- Knit Fronts in the same manner as for Back.
- Knit Sleeves following the contour line with picot hem.
- Block out each piece to size and press.
- Join both shoulders.
- Set the pattern paper for the neckband and arrange required number of needles to B position.
- With wrong side facing, pick up loops or stitches from the neck edge and place them on the needles on B position.
- Knit neckband without shaping.
- Pick up the sinker loops from the first row of neckband and place them onto corresponding needles. (Fig.2)

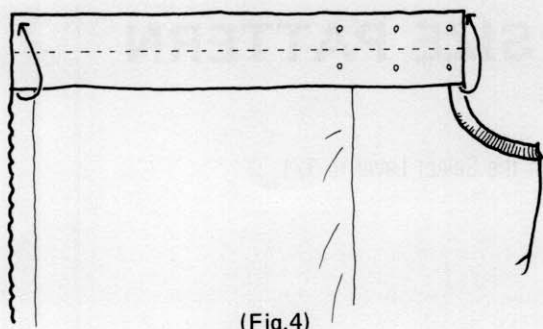

(Fig. 4)

- Cast off using back stitch method.
- Set the pattern paper for Front band and arrange required number of needles in B position.
- With wrong side facing, pick up the stitches from the front edge and place on the needles in B position.
- Knit one Frontband in the same way as for neckband making buttonholes at the marked position. (Fig.3)

Buttonholes by transferring stitches — page 20

- Knit second Front band in the same way as for the first one but marking the positions of buttonholes.
- Join side and sleeve seams.
- Set in Sleeves.
- Sew buttons on marked position on the front band.

C — 6 BABY'S LEGGINGS

FRONT & BACK

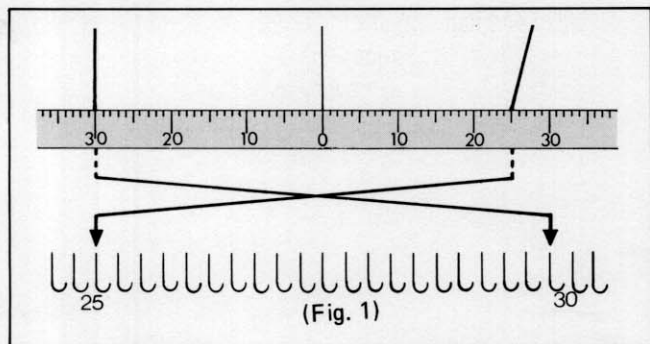

(Fig. 1)

- Knit up to the bottom of ankleband with doubled hem waistband following the contour line and remove on waste knitting.
- Knit 2nd piece in the same way as for the first one, but reverse the shaping. (Fig.1)
- Block out each pieces to size and press.
- Knit Ankleband in K1.P1. Rib and joint to Leggings.
- Join centre seams on back and front leaving an opening for elastic inside the waistband. (Fig.2)
- Insert elastic through the waistband. (Fig.3)

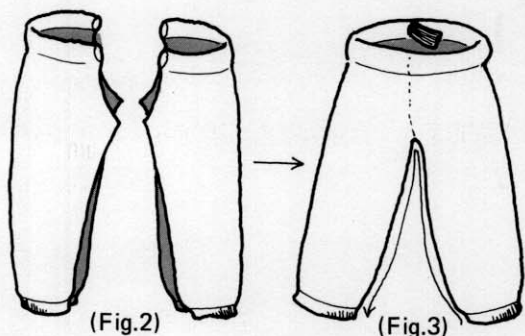

(Fig.2)

(Fig.3)

C — 7 BABY'S PANTS

BACK — Pattern I, FRONT — Pattern II, LEGBAND — Pattern III

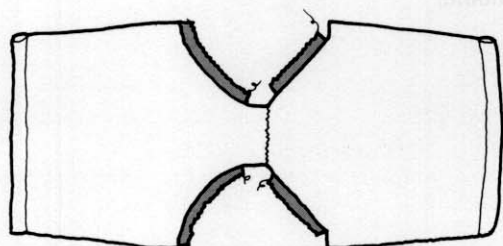

(Fig. 1)

- Knit Back and Front with doubled hem waistband, following the contour line. (Work partial knitting at leg openings) Remove on waste knittings.
 - Block out each piece to size and press.
 - Join front and back crutch using grafting method. (Fig.1)
- Grafting — page 23**
- Knit Legband in K1.P1. Rib and join to leg opening.
 - Join the side seams leaving an opening for elastic in waistband.
 - Insert elastic through waistband.

TO KNIT WITH FULL SIZE PATTERN

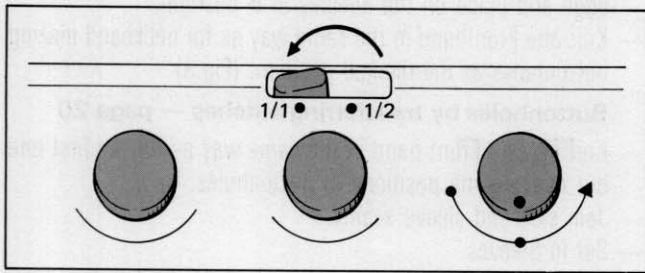

1. Set the Select Lever to 1/1.

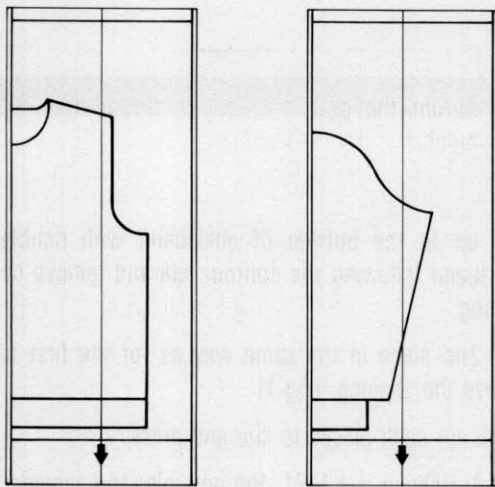

2. Since Blank Pattern Paper is 33cm., in width, draw half pattern on the pattern paper.

Use left side line as standard vertical line.

* Blank Pattern Paper is an optional accessory.

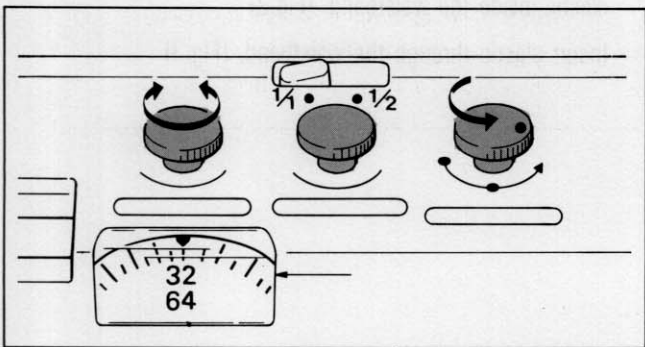

3. Set the row number in the same way as for half size pattern.

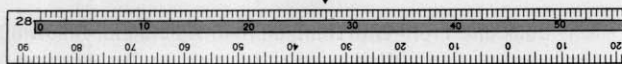
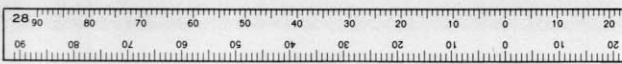

4. Stitch Scale

Since the Stitch Scales supplied are for half size pattern, re-graduate scales for full size half pattern.

An additional Stitch Scale set for full size patterns is available.



IF INCORRECTLY KNITTED

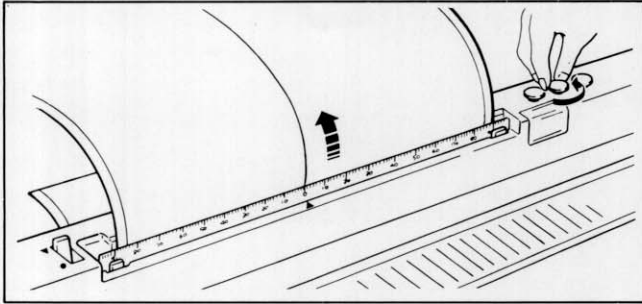

When you unravel the incorrectly knitted row, return the pattern paper by as many rows as the rows unravelled, counting clicking sounds by turning the Feeding Dial in the R direction.

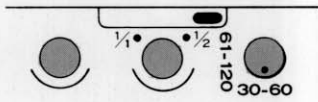
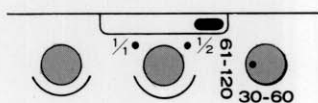
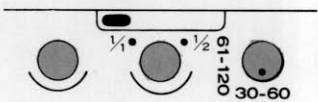
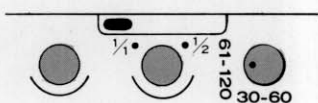
Select Lever at 1/2	Change Dial at 30—60		Return the pattern paper by the same number of rows unravelled.
	Change Dial at 61—120		Return the pattern paper by half the number of rows as are unravelled. (Unravel an even number of rows.)
Select Lever at 1/1	Change Dial at 30—60		Return the pattern paper by twice the number of rows as are unravelled.
	Change Dial at 61—120		Return the pattern paper by the same number of rows are unravelled. (Unravel an even number of rows.)

MEMO

IF INCORRECTLY KNITTED

When you observe the incorrectly knitted row, return the pattern paper to the correct page by an easy way as the two arrows and counting blocks shown by the top of the feeding box in the 4 direction.

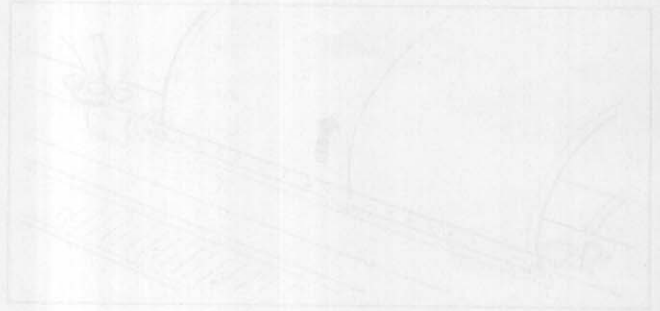

<p>Return the pattern paper by the same number of rows unknitted.</p>	<p>Change dial at 30-60</p>	<p>Select Level at 1/2</p>
<p>Return the pattern paper by half the number of rows as set unknitted (travel an even number of rows)</p>	<p>Change dial at 81-120</p>	
<p>Return the pattern paper by twice the number of rows as set unknitted.</p>	<p>Change dial at 30-60</p>	<p>Select Level at 1/1</p>
<p>Return the pattern paper by the same number of rows set unknitted (travel an even number of rows)</p>	<p>Change dial at 81-120</p>	