

**SERVICE MANUAL FOR KH-940/KH-930
ELECTROKNIT. WITH KG-88II/89II/93**

brother

CONTENTS

*KH-940/KH-930

1. PRODUCT CHARACTERISTICS	1
2-1 PRODUCT SPECIFICATIONS	1
2-2 DIFFERENT POINTS BETWEEN KH-940 AND KH-930	2
3. QUICK TROUBLESHOOTING CHART	3
4. NOTES OF CAUTION FOR CHECKING AND REPAIR	6
5. CIRCUITRY CONFIGURATION	7
5.1 Main PC Board	7
5.2 Operation PC Board	7
5.3 Left Position Sensor PC Board and Right Position Sensor PC Board	7
5.4 Encoder PC Board	7
5.5 Solenoid PC Board	8
5.6 Relationship between Needle Selector Plate, Solenoid, Needle Number, and Belt Phase Signals	8
5.7 FB100	8
5.8 Power Supply	8
6. TEST PROGRAMS	9
6.1 Test 885	9
6.2 Test 886	12
6.3 Test 888	12
6.4 Test 889	13
7. CHECKING AND REPAIR OF THE POWER SYSTEM	14
7.1 Checking the Power Cords	14
7.2 Checking the AC Power Source	14
7.3 Replacing the Fuses (F601)	14
7.4 Checking the Power Switch	14
7.5 Checking the Power Transformer	14
8. CHECKING AND REPAIR OF THE POWER SUPPLY PC BOARD	15
8.1 Checking the Fuses (F201,202)	15
8.2 Checking Output Voltage	15
9. CHECKING THE NEEDLE SELECTOR	16
9.1 Checking with the Power Switch Turned Off	16
9.2 Checking with the Power Switch Turned On	16
9.3 Checking with the Solenoid On	16
9.4 Checking the Solenoid	17
9.5 Checking Needle Selection by Test Pattern	18
10. REMOVING ELECTRICAL/ELECTRONIC PARTS AND PC BOARDS	19
10.1 Removing the Lithium Battery and the Main PC Board	19

10.2 Reassembly of the main PC board & pattern case whole unit	21
10.3 Removing the Operation PC Board	22
10.4 Reassembling the Operation PC Board and the Main PC Board	22
10.5 Removing the Encoder PC Board and the Slit Disc	23
10.6 Removing the Power Supply Board	24
10.7 Removing the Left Position Sensor PC Board	24
10.8 Removing the Right Position Sensor PC Board	25
10.9 Removing the Filter PC Board	25
10.10 Removing the Transformer	26
11. WHEN "888" BLINKS WITH THE POWER SWITCH ON (WITH KH-930) OR WHEN CREATED PATTERN DISAPPEAR WITH THE POWER SWITCH ON (WITH KH-940)	27
12. DISASSEMBLY, ASSEMBLY, AND ADJUSTMENT OF K CARRIAGE	28
12.1 Disassembling the K Carriage	28
12.2 Assembling the K Carriage	33
12.3 Functional Check of the K Carriage	39
12.4 How to Adjust the K Carriage	40
13. DISASSEMBLY, ASSEMBLY, AND ADJUSTMENT OF L CARRIAGE	41
13.1 Disassembling the L Carriage	41
13.2 Assembling the L Carriage	43
13.3 How to Adjust the L Carriage	47
14. DISASSEMBLY AND ASSEMBLY OF THE MAIN BODY	49
14.1 Disassembling the Main Body	49
14.2 Assembling the Main Body	51
14.3 How to adjust the needle bed comb	55
15. ADJUSTMENT AND CHECK OF THE NEEDLE SELECTOR MECHANISM	56
15.1 Adjusting the Card Reader Guide Plate	56
15.2 Adjusting the Rotary Cam Position	56
15.3 Checking the Needle Selector Mechanism	57
*KG-88II/89II/93	
1. KG-88II/89II/93 product characteristics and points different from KG-88/89	58
2. Product specifications	58
3. Differences between KG-88II/89II/93 and KG-88/89 in the disassembly and mounting of the G carriage	58
4. Differences between KG-88II/89II/93 and KG-88/89 in the sensor	59
5. Troubleshooting	59

1. **The application of electronics to a pattern knitting device, and automatic needle selection through the internalization of pattern data utilizing a microcomputer.**
2. **Patterns stored in memory may be altered in a variety of ways:**
 - ① The orientation of the pattern may be changed.
 - ② The pattern may be expanded to two times horizontally as well as vertically, and up to four times by expanding the pattern two times in both directions simultaneously.
 - ③ The pattern may be knitted face to face/back to back.
 - ④ KHC and KRC patterns may be knitted by merely switching the pattern variation key.
3. **Large sized patterns may be knitted.**
KH-940: 200 Stitches × 998 Rows & 200 Stitches × 274 Rows
KH-930: 200 Stitches × 68 Rows
4. **Original patterns may be knitted through key input.**
5. **Patterns stored in memory are not erased when the power is turned off.**
6. **Original pattern data may be stored or called up with external memory devices. (FB100KM).**
7. **Intarsia and thread lace may be knitted with K carriage.**

Pitch, number of needles	4.5 mm, 200 needles
Weight	15.6 kg
Size	L 1129 mm x W 216 mm x H 97 mm
Color	White
Needle bed material	Tempered steel can be installed
Knit reader	KL116 may be used.
KR-KHC-KRC usage	KR850, 830, KHC820, KRC830/900 T carriages may be used (KA-8300)
Auto carriages	KG93 may be used
External memory devices	FB100KM may be used
Pattern programming device	KH-940: PPD-110 may be used KH-930: PPD-110 & PPD-100 may be used
Pattern knitting function	Additional thread lace, intarsia with KH-910
Pattern needle device	Automatic needle selection by internal microcomputer
Voltage-power requirements	115, 220, 230, 240V / 25 W

<Accessories>

- Pattern book
- Design sheet

2-2 DIFFERENT POINTS BETWEEN KH-940 AND KH-930

Item	Model	KH-940	KH-930
1. Memory capacity for the original pattern		Max. : 254,400 stitches (about 50 pages on the Design sheet.)	Max. : 13,600 stitches (about 3 pages on the Design sheet.)
2. The track numbers when using FBI00KM		Max. : 2 tracks (The capacity of one track: 254,400 sts..)	Max. : 40 tracks (The capacity of one track: 13,600 sts..)
3. TEST PROGRAMS		KH-940 has TEST 885, 888, and 889. (It does not have 886 & 887.) (a) It has only the error digit "E3" at step 2 of TEST 885. (b) TEST 888 requires about 35 seconds for completion. (c) The all lamps (LEDs) on the operation panel light on while step 1 of TEST 889 is running.	KH-930 has TEST 885, 886, 888, and 889. (a) It has the error digits "E3" ~ "E6" at step 2 of TEST 885. (b) TEST 888 requires 2 ~ 3 seconds for completion. (c) The all lamps (LEDs) on the operation panel blink simultaneously while step 1 of TEST 889 is running.
4. When the lithium battery is consumed up or the created pattern data in the memory (RAM) is damaged.		The data in the memory (RAM) is cleared automatically without blinking of "888".	"888" blinks on the memo display.

* OTHERS

- (a) KH-940 can be used with the pattern disk "STITCH WORLD EXTRAS".
- (b) The 940 can load the pattern from the disk for KH-930 or KH-930M (= the disk which has the data of KH-930 or KH-930M).
But, it can not erase or enter the pattern on the disk for KH-930 or KH-930M (in this case, error message "0" appears in the display of operation panel).
- (c) The data can be transferred from PPD-100 (either mode setting is OK) to KH-940.
But, the data can not be transferred from KH-940 to PPD-100 (in this case, error message "0" appears in the display of operation panel).

3. QUICK TROUBLESHOOTING CHART

	Trouble	Origin	Remedy	Notes
K carriage	K carriage does not move easily	1. Carriage cam sliding. Part is out of oil	1. Oil the butt of the needle and the stitch cam	
		2. Needle bed sliding. Part is out of oil	2. Oil front and rear rails of body and carriage	
		3. The sinker plate and gate peg are in contact	3. Correct sinker plate front-rear adjustment	See P. 40
		4. The sinker plate is lifting the knitting needle	4. Correct vertical adjustment of sinker plate	See P. 40
		5. The gage is too tight	5. Loosen knitting gage	
		6. Poor horizontal adjustment of rotary cam. (Rotary cam is positioned too much to the left.)	6. Correct horizontal adjustment of rotary cam	See P. 56
Knitting	Floating stitches. Stitches get tucked.	1. Too much gap between sinker plate and gate peg	1. Correct front-rear adjustment of sinker plate	See P. 40
		2. Too much gap between sinker plate and needle	2. Correct vertical adjustment of sinker plate	See P. 40
		3. Needle latch not functioning properly	3. Change needle	
		4. The gage is too tight	4. Loosen knitting gage	
	Stitches irregular (uneven) Lateral stripe is produced occasionally	1. Uneven speed in carriage operation	1. Make carriage operation speed constant.	
		2. Poor yarn feed	2. Loosen spring tension of the yarn tension disk	
	Knitting gage of the right needle bed and that of the left is different	1. Attachment of needle bed comb uneven left to right	1. Adjust the needle bed comb position even left to right.	See P. 55
	The carriage gets stuck while knitting	1. The needle bed is damaged	1. Repair needle bed	
2. The butt of the needle is damaged		2. Replace needle		
When the change knob is set to <KCI>, end needle selection is not possible	1. End needle selection cam problem (function is heavy, worn)	1. Replace end needle selection cam	See P. 32, P. 33	
When change knob is set to <KCI>, the end needle is always selected	1. Separation cam is bad (function is heavy, worn)	1. Replace the separation cam and separation cam screw		
L carriage	The L carriage gets stuck midway and will not move	1. The gage is too tight	1. Loosen knitting gage	
		2. The L carriage was operated with pulling it up.	2. Operate carriage correctly	
		3. The spring plate is damaged	3. Replace spring plate	See P. 46
	Comb teeth catch stitches	1. The gage is too loose	1. Tighten knitting gage	
		2. Yarn feeds poorly	2. Use wax on yarn tension wax stand	
		3. Speed of operation is too fast	3. Operate in proper speed	
		4. Gate peg bent	4. Adjust the gate peg	

	Trouble	Origin	Remedy	Notes
L carriage	Stitches are dropped	1. Poor latch needle operation	1. Replace the needle	
		2. Gate peg bent	2. Adjust gate peg	
		3. Needle transfer plate position improper	3. Correct right-left adjustment of needle transfer plate	See P. 47
		4. Main cam improperly positioned	4. Correct front-rear adjustment of Main cam	See P. 43
		5. Spring plate position improper	5. Correct horizontal adjustment of spring plate	See P. 47
		6. Sinker plate bent	6. Correct bend in sinker plate	See P. 48
	End needle is selected	1. End needle selection change cam for L is not properly set	1. Set end needle selection change cam for L properly	
		2. End needle selection cam is bad	2. Replace end needle selection cam	
Needle selection	Wrong needle is selected	1. Encoder sensor P.C. board problem	1. Check encoder sensor P.C.B. by TEST 885	See P. 9
		2. Right/Left position sensor problem	2. Check Right/Left position sensor P.C.B. by TEST 885	See P. 9
		3. Main P.C. board problem	3. Replace the Main P.C. board when all other possibilities have been checked and no problem discovered	See P. 16
		4. Needle selector mechanism problem	4. Check needle selection mechanism and needle selector solenoid	See P. 16
		5. Carriage problem	5. Check carriage	See P. 39
		6. Power problem	6. Check power supply system	See P. 14
		7. Operation problem	7. Operate correctly	
	The same needle does not come out	1. The butt or shank of needle bent	1. Replace needle	
		2. Left-right measurement problem between rotary cam lever and rotary cam	2. Correct right-left adjustment of rotary cam (needle selection mechanism)	See P. 56
	Unnecessary needles come out at 8 cycles	1. There is grease between the needle selector plates.	1. Wipe grease off needle selector plate	
		2. The N.S.P. operation lever is squeezed between the operation lever presser and the rotary cam holder body N.S.P. operation lever does not move easily.	2. Replace needle selector unit	See P. 50, P. 51
		3. Needle bent or broken	3. Replace knitting needle	
		4. Hook of needle selector plate spring is making contact with other needle selector plates	4. Correct to hook the needle selector spring	
Knitting needle not selected at 8 cycles	1. The butt or shank of needle bent	1. Replace knitting needle		
	2. Holes in needle bed worn and enlarged	2. Replace needle bed		

Trouble		Origin	Remedy	Notes
Needle selection	No needle selection in 16th cycle	1. The rotary cam lever remains at lower position.	1. Lubricate the card reader guide plate	
		2. The position of card reader guide plate is too much to the left.	2. Correct horizontal adjustment of card reader guide plate	See P. 56
		3. Rotary cam is out of adjustment horizontally. Needle selector plate travel is too short (Rotary cam is positioned too much to the right.)	3. Correct horizontal adjustment of rotary cam	See P. 56
		4. Needle selector solenoid remains power on.	4. Check needle selector solenoid	P. 16, P. 17
	Unnecessary needles come out at 16th cycles	1. The rotary cam lever remains at upper position	1. Lubricate the card reader guide plate	
		2. Rotary cam is out of adjustment horizontally. Needle selector plate travel is too large (Rotary cam is positioned too much to the left.)	2. Correct horizontal adjustment of card reader guide plate	See P. 56
		3. Needle selector solenoid remains power off.	3. Check needle selector solenoid	P. 16, P. 17
	Needle selection position is off by 8 stitches	1. The position sensor is out of adjustment	1. Correct voltage adjustment of position sensor and mounting position	See P. 9
		2. Connection between belt and carriage connecting plate at carriage forward travel opening (especially that of the L carriage) is bad	2. Replace the connecting plate. Replace the belt pulley brake (Friction plate spring)	See P. 32, P. 33
		3. Belt connecting hole is damaged	3. Replace the belt	See P. 54
		4. Carriage and belt sensor circuitry system is bad	4. Replace the encoder PC board or replace the main PC board	P. 19, P. 23
		5. Slit disc is damaged	5. Replace the slit disc	See P. 23
6. K carriage and L carriage judgment circuits are bad		6. Replace the left position sensor PC board, the encoder PC board, the main PC board, in that order *Check and replace the K carriage and L carriage sensor magnets		

4. NOTES OF CAUTION FOR CHECKING AND REPAIR

In order to avoid secondary damage, please pay attention to the following points:

- (1) When assembling or disassembling the machine, always ensure that the power cord is unplugged from the socket.
- (2) Be sure not to pull the plug by the cord when disconnecting it from the socket.
- (3) Tighten nuts and screws down securely.
- (4) Be sure not to lose any nuts, screws, or washers, and ensure not to leave any of them in the machine during assembly. These can be the cause of shorts in the electrical circuitry.
- (5) Do not damage the cords or PC boards with the soldering iron.
- (6) The electrical parts used in the machine can be damaged by static electricity. Therefore, be sure to handle PC boards by the edges and to refrain from allowing your hands to come into direct contact with parts.
- (7) When transporting PC boards, it is best to wrap them in aluminum foil or in an anti static electricity bag. When transporting the main PC board assembly, always ensure that the lithium battery has been removed. Never wrap the assembly with the lithium battery still attached. Polyethylene and styrene can cause static electricity and should not be used for wrapping.
- (8) After the completion of assembly or disassembly, check to ensure that all connectors are properly connected and that the equipment operates normally.
- (9) The main power should be the same as the rating of the machine.
- (10) Ensure that the positive and negative terminals of the lithium battery are not shorted.

2. CIRCUITRY CONFIGURATION



Fig. 2-1. Main PC Board

Fig. 2-2. Operation PC Board

Fig. 2-3. Left Position Sensor PC Board and Right Position Sensor PC Board

Fig. 2-4. Position Sensor PC Board and Right Position Sensor PC Board

Fig. 2-5. Left Position Sensor PC Board and Right Position Sensor PC Board

Fig. 2-6. Position Sensor PC Board and Right Position Sensor PC Board

The diagram shows the electrical connections between the various components. The power input is connected to the main PC board, which contains the transformer, rectifier, and regulator. The regulator provides a stable voltage to the microcontroller. The microcontroller is connected to the motor driver, which controls the motor. The position sensors provide feedback to the microcontroller. The lithium battery is used as a backup power source for the microcontroller. The diagram also shows the connections for the operation PC board, which is used to control the machine's operation. The position sensor boards are used to detect the machine's position and provide feedback to the microcontroller.

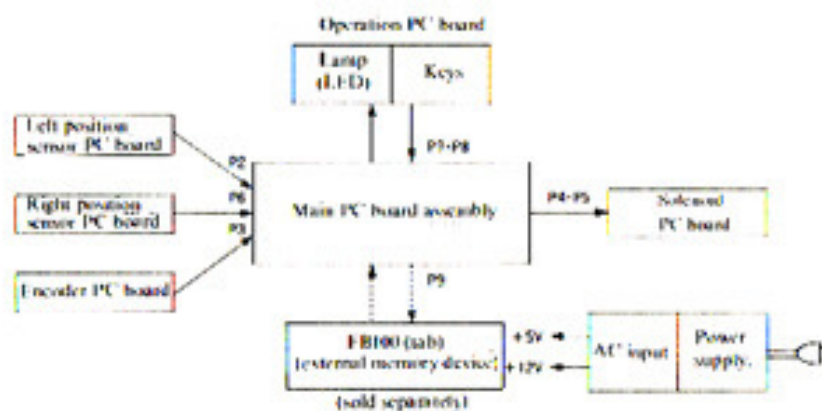

Figure 5-1

2) Fig. 5-1 shows the circuitry configuration of the KH-930.

5.1 Main PC Board

The main PC board is the main control portion of the equipment. It is comprised of the computer, memory, and control parts, etc.

5.2 Operation PC Board

The operation PC board is the key PC board, made up of the lamps (LED) and keys. It is connected to the main PC board by a flat cable (P7, P8).

5.3 Left Position Sensor PC Board and Right Position Sensor PC Board

The left and right position sensor PC boards are what send out the carriage position signal. It is connected to the main PC board by a connector (S2, S6).

The position sensor signal (pin 3 of S2, S6) is normally DC 1.6 - 1.8V, but when the K carriage sensor magnet approaches the position sensor, it becomes DC 3.5V or more, and less than DC 0.7V when the L carriage approaches. When G carriage sensor magnet approaches, it begins at DC 0.7V and thereafter immediately changes to DC 3.2V or more. It is by these changes in voltage that the computer is able to judge which carriage has passed by (refer to Fig. 5-2).

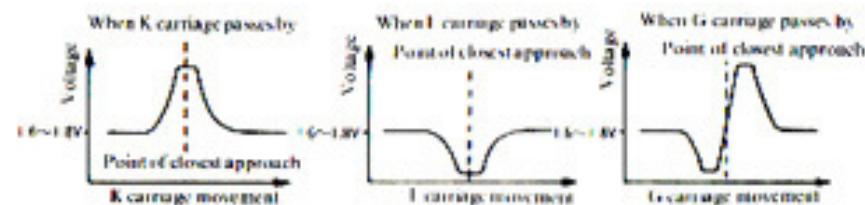

Figure 5-2

5.4 Encoder PC Board

The encoder PC board emits signals required in the detection of the direction and amount of carriage movement and in solenoid selection. It is connected to the main PC board by a connector (S3).

The V1 (Pin 4 of S3), V2 (Pin 3 of S3), and BP (Pin 5 of S3) signals are configured as shown in figure 5-3 below:

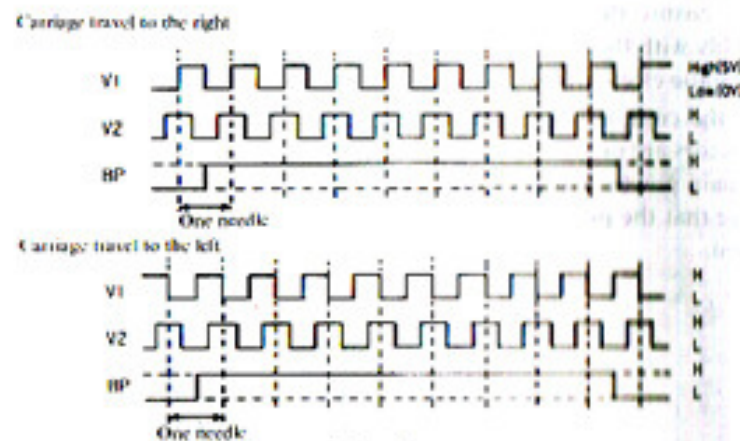

Figure 5-3

The amount and direction of movement of the carriage are detected via the V1 and V2 signals, and the type of engagement between the belt and the carriage is detected via the BP signal (Belt phase signal). There are two types of engagement, discriminated between by sensing whether the BP signal is high or low when the carriage passes the position sensor.

5.5 Solenoid PC Board

The solenoid PC board is a PC board which is acted upon by the needle selector device. It is connected to the main PC board assembly by a connector (S4, S5). There are 16 needle selector solenoids, with numbers on them, counted sequentially from left to right. There are 8 needle selector plates, the relationship to the rotary cam of which is given in figure 5-4 below.



Figure 5-4

5.6 Relationship between Needle Selector Plate, Solenoid, Needle Number, and Belt Phase Signals

Needle selector plate	Solenoid	Yellow needle numbers (left)								Green needle numbers (right)						
		0	8	100	84	68	52	36	20	4	13	29	45	61	77	93
1	0	8	100	84	68	52	36	20	4		13	29	45	61	77	93
2	1	9	99	83	67	51	35	19	3		14	30	46	62	78	94
3	2	A	98	82	66	50	34	18	2		15	31	47	63	79	95
4	3	B	97	81	65	49	33	17	1		16	32	48	64	80	96
5	4	C	96	80	64	48	32	16		1	17	33	49	65	81	97
6	5	D	95	79	63	47	31	15		2	18	34	50	66	82	98
7	6	E	94	78	62	46	30	14		3	19	35	51	67	83	99
8	7	F	93	77	61	45	29	13		4	20	36	52	68	84	100
1	8	0	92	76	60	44	28	12		5	21	37	53	69	85	
2	9	1	91	75	59	43	27	11		6	22	38	54	70	86	
3	A	2	90	74	58	42	26	10		7	23	39	55	71	87	
4	B	3	89	73	57	41	25	9		8	24	40	56	72	88	
5	C	4	88	72	56	40	24	8		9	25	41	57	73	89	
6	D	5	87	71	55	39	23	7		10	26	42	58	74	90	
7	E	6	86	70	54	38	22	6		11	27	43	59	75	91	
8	F	7	85	69	53	37	21	5		12	28	44	60	76	92	
BP signal	1.	H	K carriage left turn mark													
	H	1.	K carriage right turn mark													
	H	1.	L carriage left turn mark													
	H	1.	L carriage right turn mark													

5.7 FBI00KM (external memory device-sold separately)

The FBI00KM is a 3.5 inch floppy disc drive unit which stores the patterns made by the PPD110/100 or KH940/930. It has an 80 kilo byte capacity. It is connected to the Main PC board connector (P9) by an Interface cable for FBI00/KH.

5.8 Power

Very generally, the components of the power system may be divided into the AC cord, the power switch, the filter PC board, the power transformer, and the power PC board. Input power passes through the AC cord and the power switch and goes to the filter PC board where line noise is filtered out. It is next reduced in voltage by the transformer, separated and delivered to two circuits. These are finally transformed by the power PC board into DC 5V and DC 12V currents.

The DC 12V current is supplied only to the interface circuits FBI00 of the solenoids and buzzers, all other electrical requirements being met with the DC 5V current.

6. TEST PROGRAMS

6.1 Test 885 Needle Position Detect Circuit Test

- **Step 1** — Display right or left position signal voltage. The computer will report that it has detected either the K, L, or G sensor magnet.

■ Test procedure

- (1) Turn the power switch on.
- (2) Turn the display off by pushing the **CE** key.
- (3) Input the digits **[8][8][5]** and push the **STEP** key.

The voltage of the left position signal will be indicated in the display (for example, **[1][7][6]** indicates 1.76V). A yellow lamp will light, indicating that the left side is being checked. When there is no carriage sensor magnet in front of the sensor, a voltage of 1.76V or 1.92V will be indicated. At this point, if the VR on the left position sensor PC board is turned, the voltage displayed in the display will also change.

*Note:

In the event that the voltage displayed in the display does not fall between 1.76V and 1.92V, adjust via the VR on the left position sensor PC board. This adjustment should be done as follows: first, turn the VR slowly until 1.92V is displayed, then turn it slowly to the left until 1.76V is displayed and stop.

*When there is a problem

When adjustment cannot be effected, replace the position sensor PC board and attempt the above adjustment again.

- (4) Place the K carriage sensor magnet in front of the sensor (with the change knob on <KC(II)>). At this time, the voltage indicated in the display should be 3.36V or over. When voltage is 3.04V or over and the computer detects the K carriage (N), a "1" will be displayed in the memo display.
- (5) With the K carriage sensor magnet in front of the sensor, turn the change knob to <N.L> (plain stitch). Ensure that the voltage is below 2.72V. The memo display will not turn off even if the indicated voltage drops below 3.04V. If the direction of carriage movement changes from right to left (when the yellow lamp is on), it will turn off.

- (6) Place the L carriage sensor magnet in front of the sensor. 0V should be indicated. When voltage drops over 0.80V or lower and the computer detects the L carriage (S), the memo display will indicate a "2."
- (7) Pass the G carriage sensor magnet across the outside of the sensor.

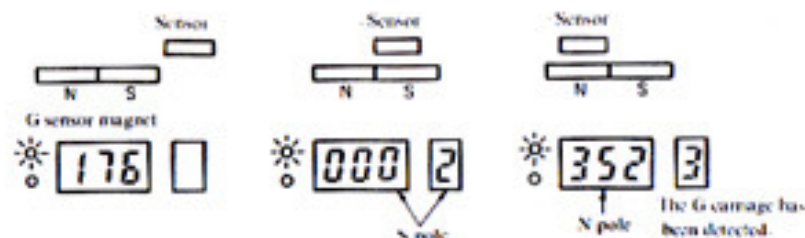

When detecting the N pole magnet within 3 needles after detecting the S pole magnet, a 3 is displayed, indicating detection of the G carriage.

- (8) Push the **GREEN** key. The voltage of the right position sensor signal will be displayed. The green lamp will light indicating that the right side is being checked.
- (9) Using the sequence given in (4)-(7) above, check the conditions of the K carriage, the L carriage, and the G carriage on the left.

*Note:

To recheck the left side, pushing the **YELLOW** key will put the equipment in the condition given in (3) above.

When there is no problem by performing the checks given above. Push the **STEP** key, and the voltage display on the display well as the YELLOW, GREEN, and START lamps will be turned off. Then, the step 2 test will begin.

*When there is a problem

By performing the checks given above, check the mounting position of the position sensor PC board horizontally and vertically to see that each have the proper voltages. If they do not, replace the position sensor PC board.

If voltage goes down during the K carriage check or up during the L carriage check, replace the carriage sensor magnet. If there is some abnormality during the G carriage check, check the G carriage sensor magnet. In the event that the magnet is properly mounted, replace the G magnet holder. If there is no problem with the indicated voltage, but nothing is displayed in the memo display, perform the step 2 check (refer to figure 6-1).

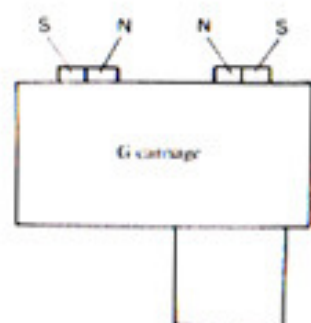

Figure 6-1

*The magnet with the white mark (N) is on the inside.

• **Step 2** — This is to check to see whether, of the needle position detect circuit signals, the V_1 , V_2 , BP, and iRQ (count edge) signals have been properly sent to the computer.

(10) Move the carriage forward and backward one time (20 needles or more). If a problem is noted during step 2, an "E" will be displayed in the memo display, and an error digit in the display. When there is an error digit in the display, the step will proceed no further.

If the **[STEP]** key is pressed, the step 2 test will be repeated.

Error digit

*In case of KH940

KH940 has error digit "E3" only in this step.

E3: the V_1 , V_2 signals or iRQ signal are not sent correctly to the Main P.C. board assembly when the carriage is moving.

*In case of KH930

KH930 has error digits "E3" ~ "E6" in this step.

E3: the V_1 , V_2 signals are sent to the main P.C. board assembly correctly, but iRQ signal is not sent when the carriage moves to the left.

E4: the V_1 , V_2 signals are sent to the main P.C. board assembly correctly, but iRQ signal is not sent when the carriage moves to the right.

E5: the V_1 , V_2 signals are sent to the main P.C. board assembly correctly, but iRQ signal is not sent when the carriage is moving in either direction.

E6: the iRQ signal is sent when V_2 is LOW.

***When "E3" (In case of KH940) or "E3" ~ "E6" are indicated in the display (In case of KH930).**

After the step 2 is completed, if the error digit ("E3" or "E3" ~ "E6") is indicated in the display, replace the Main P.C. Board assembly, then perform the check again starting with step 1.

When other than "E3" (KH940)/"E3" ~ "E6" (KH930)

The condition of the V_1 , V_2 or BP signals will be indicated in a 3 digit display.

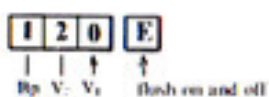

0: proper condition.

1: The signal remains High

2: The signal remains Low

***When there is a problem (the condition of V_1 , V_2 , or BP signals is indicated in the displays.)**

After the check is completed, if the condition of V_1 , V_2 , or BP signals is indicated in the displays, replace the encoder PC board, then perform the check again starting with step 1.

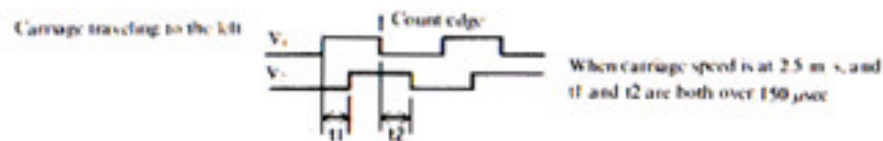
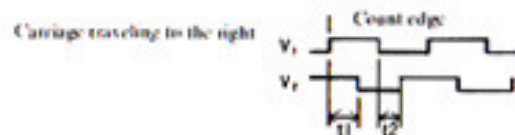

If no problems are noted in step 2, a buzzer will sound, and the READY lamp will light.

***When there is a problem**

After the check is completed, if the READY lamp does not light, or if an error digit is not indicated, replace the encoder PC board. After replacement perform the check again starting with step one.

(11) Press the **[STEP]** key.

Move the carriage from the outside of the left turn mark toward the center.
The step 3 test will begin.

• **Step 3** —Mounting position tests for the left and right position sensor PC boards

When the K carriage passes the left turn mark, and when the L carriage passes the right turn mark, during the time from the belt phase signal reversing to the first V_1 count edge in the right or left position signal, the V_1 count edge should be one or more.

① K left turn mark

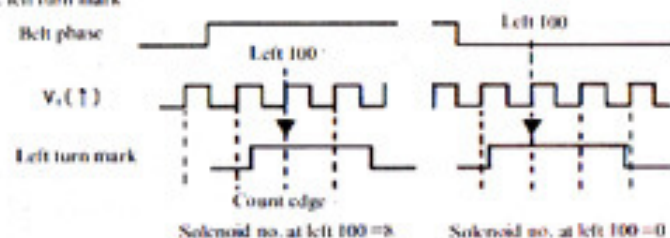

② L right turn mark

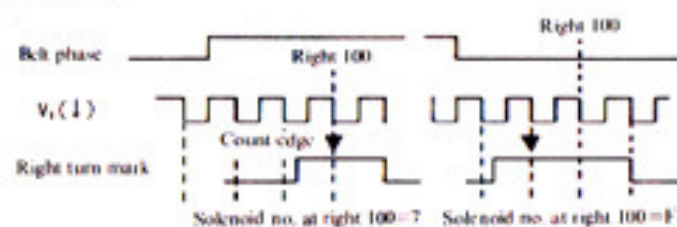

When the L carriage passes the left turn mark, and when the K carriage passes the right turn mark V_1 count edge should be one or more during the time from the first V_1 count edge in the right or left position signal to the belt phase signal reversing.

③ L left turn mark

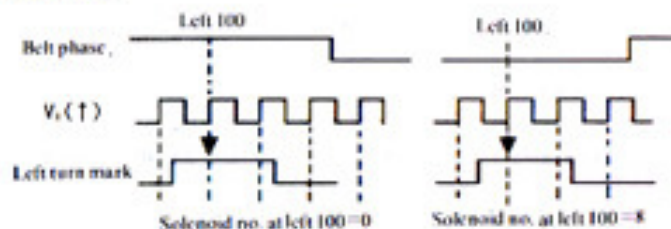

④ K right turn mark

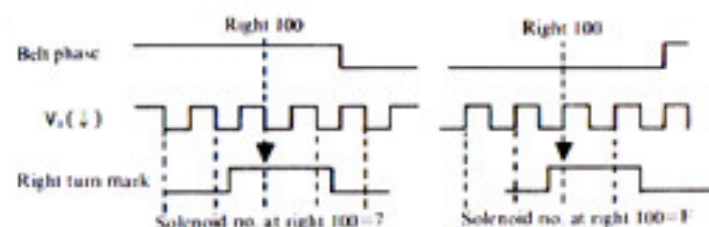

If there is no problem, the READY lamp will go on, and the carriage type and belt phase signal level will be displayed in two digits. In the memo display, the digit for the count edge will be indicated.

First digit: Belt phase signal	Display
When H	1
When L	0
Second digit: Carriage type	Display
K carriage	1
L carriage	2
G carriage	3

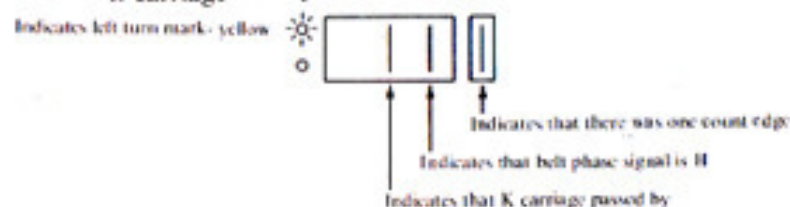

	Memo display carriage	Turn mark	Count edge
①	K	Left	1 ~ 2
②	L	Right	1 ~ 2
③	L	Left	2 ~ 3
④	K	Right	2 ~ 3

When there is a problem within step 3, an "E" will be displayed in the memo display, and also the carriage type and belt phase signal level will be displayed in the display.

***When there is a problem**

When an error is registered, check the position sensor PC board via the items as given in chart 1. The standard position for the magnet sensors are at the 100th needle to the left and to the right. After checking these items, repeat the checks from step 1.

Chart 1

Item \ Error	Left position sensor	Right position sensor
When there is an error with the K carriage	Leans toward the inside	Leans toward the outside
When there is an error with the L carriage	Leans toward the outside	Leans toward the inside

When the READY lamp lights, or when an "E" is displayed, press the step key so that you can repeat the step 3 test. The 885 test is finished by turning the power switch off. With the STEP key, when the belt phase signals ①, ②, ③, and ④ of step 3 are H or L, altogether, a total of 8 checks are performed.

6.2 Test 886 Needle Number Indication

***Only KH930 has this test program, KH940 does not have this one.**

■ Test procedure

- ① Put the carriage out beyond the turn mark and turn the power switch on.
- ② Turn the display off by pushing the [CE] key.
- ③ Input the digits [8][8][6] and push the [STEP] key.
- ④ When the carriage sensor magnet passes the turn mark, the indication will start.

The position of the carriage sensor magnet (the magnet on the direction of travel for the G carriage) will be indicated by its needle number (the number of the needle position indicator). It is normal for the actual sensor magnet position to differ from that indicated by one needle to the left or right. The computer does not discriminate. The solenoid being controlled by the computer will also be indicated by a digit or a letter, 0-F, according to the needle then being indicated on the memo display. The solenoid will be indicated, from the left, by 0, 1, 2, 3, 4, 5, 6, 7, 8, 9, A, B, C, D, E, and F.

*When there is a problem

Perform test program "885."

6.3 Test 888 Memory Test

The computer will test the memory. The execution of this test will clear the memory of the entirety of its contents.

■ Test procedure

- ① Turn the power switch on and turn the display off by pushing the [CE] key.
- ② Input the digits [8][8][8] and push the [STEP] key.
55 (HEX) will be written into all memory fields and a check will be performed to ensure that 55 has been written. Then, AA (HEX) will be written, and a check performed to see that AA has been written into all fields. When these checks are passed, a 0 is written into all fields of the memory and the READY lamp lights. If the checks are not passed, an "E" will indicate in the memo display. Pushing the [STEP] button repeats this test.

*Note

The check requires about 35 seconds for completion on KH940.

Also, it requires 2 ~ 3 seconds for completion on KH930.

Be sure not to turn the power switch off before it is completed.

*If there is a problem

If an error is registered on the display, replace the main PC board.

6.4 Test 889 Display Key Test

• Step 1 — Indicator lamps all blink.

- ① Turn the power switch on.
- ② Push the **CE** key, turning the display off.
- ③ ***In case of KH940**

Input the digits **889**, and push the **STEP** key. In the display and in the memo display window **888** and **8**, and the remaining lamps (LEDs) will all light on.

***In case of KH930**

Input the digits **889**, and push the **STEP** key. In the display and memo display window **888** and **8**, and the remaining lamps (LEDs) will all begin to blink on and off simultaneously.

- ④ Press the **STEP** key. The display and the lamps will all go off, and the step 2 test is ready. Check to ensure that the keys are functioning properly.
- ⑤ If a key is pushed, the number for that key should be displayed in the display. The numbers for each of the keys is given in chart 2.

***If there is a problem**

In the event that there is a problem, first check to ensure that the cords connected to the connectors P7 and P8 on the soldered side of the main PC board are properly joined. If they have been connected properly, then there is a problem in either the main PC board or in the operation PC board. Replace the main PC board and repeat the "889" test program. If the same problem reoccurs, that will indicate that there is a problem in the operation PC board, so replace it. In this event, the former main PC board should be normal.

When the L carriage passes the left turn mark, and when the R carriage passes the right turn mark, V_c count edge should be one or more during the time from the last V_c count edge in the right or left position - signal to the bell phase signal (V_c count).



Chart 2

Indication	Key	Indication	Key	Indication	Key
0	0	14	Green	28	◀
1	1	15	△	29	SELECTOR 2
2	2	16	▽	30	VARIATION 1
3	3	17	M key	31	VARIATION 2
4	4	18	C	32	VARIATION 5
5	5	19	SELECTOR 1	33	VARIATION 3
6	6	20	INPUT	34	VARIATION 4
7	7	21	CHECK	35	VARIATION 6
8	8	22	(((((36	VARIATION 7
9	9	23	MEMO	37	R
10	STEP	24	nothing	38	S
11	CR	25	□	39	START
12	CE	26	■		
13	Yellow	27	▶		

When there is a problem, first check to ensure that the cords connected to the connectors P7 and P8 on the soldered side of the main PC board are properly joined. If they have been connected properly, then there is a problem in either the main PC board or in the operation PC board. Replace the main PC board and repeat the "889" test program. If the same problem reoccurs, that will indicate that there is a problem in the operation PC board, so replace it. In this event, the former main PC board should be normal.

When an error is required, check the position sensor (S₁) and the S₂ sensor. When the S₁ sensor is not in the correct position, the magnet sensor on the left or right of the bell, and the magnet sensor on the right or left of the bell.

7. CHECKING AND REPAIR OF THE POWER SYSTEM

7.1 Checking the Power Cords

Ensure that there are no broken wires. Set the tester for Ω range $\lceil X \rceil$ and connect the cords to both terminals. If resistance is 0Ω , then there is no break.

7.2 Checking the AC Power Source

- ① Remove the operation panel and disconnect connector S10 from the power supply PC board.
- ② Connect the power cord and turn the power switch on.
- ③ The voltage between S10 pins 1 and 2 (the orange cord) should be about 12.5VAC, and the voltage between pins 3 and 4 (the red cord) should be about 10.5VAC.
- ④ If checks in item ③ above should reveal the voltage of either the orange or red cords to be zero, yet show no abnormalities anywhere else, it will indicate a problem in the power transformer, and the transformer should be replaced. When voltage in both the orange and red cords are 0V, the fuse in the filter PC board might be blown, or there may be a break in one of the wires, the power switch may be defective, or the power transformer may be bad.

7.3 Replacing the Fuses (F601)

Measure the resistance of both of the terminals of the filter PC board fuse (F601). If resistance is 0Ω , it is normal. If resistance measured is $\infty \Omega$, the fuse is blown and should be replaced. The capacity of the fuse is different according to the rated voltage.

Replace the fuse by referring to the indication on the filter PC board.

110 115V 1A Fuse ($\phi 5.20 \times 20$)

220 240V 0.5A Fuse ($\phi 5.20 \times 20$)

7.4 Checking the Power Switch

Measure the resistance between the pin of the AC inlet connected to power switch and the BR1 on the filter PC board. Turn the switch on and then off. Check to ensure that when the switch is on, resistance is 0Ω , and when the switch is off, it is $\infty \Omega$ (infinity).

7.5 Checking the Power Transformer

Measure the resistance between BR3 and BL3 on the filter PC board. If it registers about 10Ω , it is normal (refer to figure 7-1).

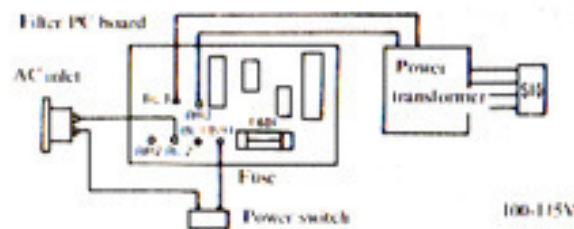
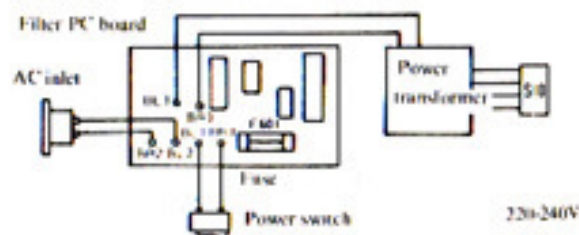

Figure 7-1



8. CHECKING AND REPAIR OF THE POWER SUPPLY PC BOARD

8.1 Checking the Fuses (F201, F202)

Measure the resistance of both of the terminals on fuses F201 and F202. If resistance is $0\ \Omega$, they are normal. If resistance is $\infty\ \Omega$, the fuse is blown and should be replaced. Fuse F201 is a 2A, and F202 a 5A, glass tube fuse ($\phi 5.2 \times 20$).

8.2 Checking Output Voltage

- ① Disconnect connector S1 from the main PC board.
- ② Check the voltage between pins 1 and 2 (pin 2 is the ground). If voltage is DC 12V ~ DC 15V or more, it is normal. If it is not normal, replace the power supply PC board. If it is 0V, check F202.
- ③ Check the voltage between pins 3 and 4 (pin 3 is the ground). If it is between DC 4.75 and 5.25V, it is normal. If it is not normal, replace the power supply PC board. If it is 0V, check F201.
- ④ Check the voltage between pins 3 and 5 (pin 3 is the ground). If it is more than DC 10V, it is normal. If it is not normal, replace the power supply PC board (refer to figure 8-1).

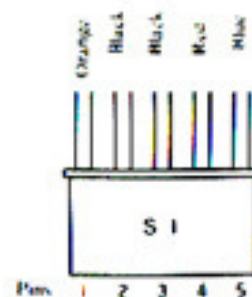

Figure 8-1

9. CHECKING THE NEEDLE SELECTOR

9.1 Checking with the Power Switch Turned Off

- ① Set the K carriage change knob to <KC(H)>, and put all of the needles in position B.
- ② Turn the power switch off, and move the K carriage to check all, the needles should be selected to position D.

***Note:**

The above check should be performed with the carriage traveling right, left, and at high speed and at low speed.

***If there is a problem**

Then it will be in the needle selector mechanism of the main body or in the carriage needle selector mechanism.

9.2 Checking with the Power Switch Turned On

- ① Set the K carriage change knob to <KC(H)>, and put all of the needles in position B.
- ② Turn the power switch on, and push the [MEMO] key. The [MEMO] key lamp should light.

***Note:**

If the [MEMO] key lamp does not light when the [MEMO] key is pushed, turn the pattern number lamp on after turning the selector (I) key on by pushing the [STEP] key. Input pattern number 100 (or any of the others from 1-555 or 881-884), push the [STEP] key twice, and push the [MEMO] key once again when the READY lamp comes on.

- ③ Select needles after the K carriage has passed the turn mark from the outside. At this point, the needles should all be selected to position B.

***Note:**

The above check should be performed with the carriage traveling right, left, and at high speed and at low speed.

***If there is a problem**

If there are needles selected to position D, perform the check given in 9.3.

9.3 Checking with the Solenoid On

- ① Remove the two operation panel screws. While holding up the left side of the panel and sliding the panel toward the left, remove it from the main body with connectors on.
(*Place the removed panel on the rear of the main body case.)
- ② Remove the three cord cover screws and the cord cover.
- ③ Set the K carriage needle change knob to <KC(H)>, and put all the needles in position A.
- ④ Turn the power switch on, and push the [MEMO] key (as in 9.2 ②).
- ⑤ Move the K carriage past the turn mark from the outside, and then move it from right to left. The armatures should all remain in the down position.



Picture 9-1

The fourth armature from the right is out of position.

***If a problem is found in the 9.2 check**

If a problem is found during the 9.2 check but the 9.3 check produced none, it will indicate a problem in either the needle selector mechanism of the main body or in the carriage needle selector mechanism (refer to 15 on P.51 and 12.3 on P.36.).

***If a problem is found in the 9.3 check**

It will indicate a problem in the electrical circuitry. Check this with the test program given in chapter 6 (885, 888). If this does not produce the answer, perform the check in 9.4 (the example shown in the picture is a solenoid no. "C" problem).

9.4 Checking the Solenoid

- ① Turn the power switch off, and disconnect connectors S4 and S5 (P4 and P5 on the main PC board).

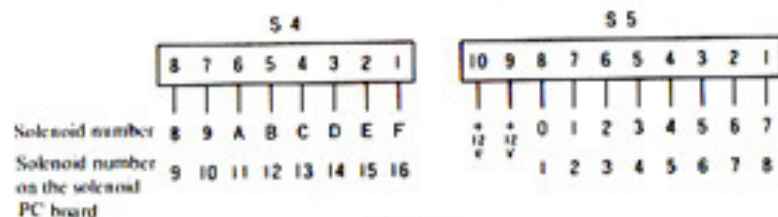

Figure 9-2

- ② Check the resistance between pin 9 or 10 of the S5 connector and the pin of the connector which corresponds to the unenergised armature. (Refer to figure 9-2. In picture 9-1, there is a problem in pin 10 of S5 or pin 9 and pin 4 of S4). Resistance should be within 140 - 150 Ω . If it is not, there is a problem, which may be found with the check given below. If no problem is found in the resistance values, perform the check given in 9.5.
- ③ Disconnect the needle selector solenoid unit (refer to on P.45 item 11). Check the resistance values of the places which correspond to the solenoids on the solenoid PC board which were found to be bad. The resistance value of the solenoid coil should be between 140 - 150 Ω , the resistance value of the solenoid signal cord should be 0, and the resistance value of the metal portion of the main body and the solenoid should be $\infty\Omega$ (refer to figure 9-3).

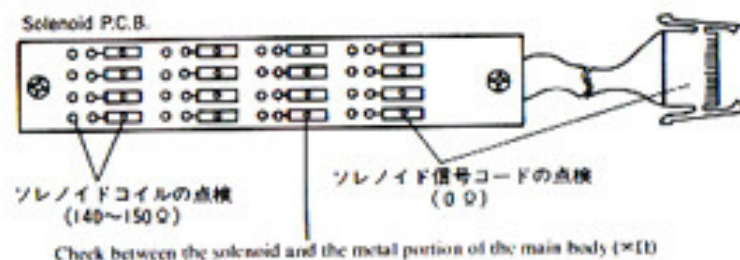

Figure 9-3

*If there is a problem

If a problem is found in a check between the solenoid coil and the solenoid chassis, replace the solenoid. If a problem is found when checking the solenoid signal cord, replace the solenoid signal cord.

9.5 Checking Needle Selection by Test Pattern

Pattern numbers 1 through 555 are internalized, but other than that, there are also 881 through 884 which are test patterns. The pattern for each of these is given in figure 9-4. The test is performed according to the following procedure.

- ① Put a sufficient number of needles in position B.
- ② Turn the power switch on and push the selector (1) key.
- ③ Push the STEP key, and then the CE key. Then, enter the digits 881-884, and push the STEP key twice. The READY lamp should light.
- ④ Turn the variation (4) (double length) switch on, and set the K carriage change knob on <KC(II)>.
- ⑤ Select needles after passing the K carriage from the outside of the turn mark. The needle selection should change after every other pass.

⑤ Test patterns



881. 1x1 alternative needle selection



882. 5x5 alternative needle selection

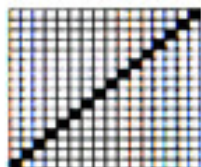

883. 1-16 needle selection



884. 1-5-5 needle selection

Figure 9-4

10. REMOVING ELECTRICAL/ELECTRONIC PARTS AND PC BOARDS

10.1 Removing the lithium battery and the Main P.C. Board

1. Removing the Pattern case whole unit (refer to 14.1).
2. Disconnect all 6 of the connectors and remove the 6 screws. (Refer to picture 10-1)

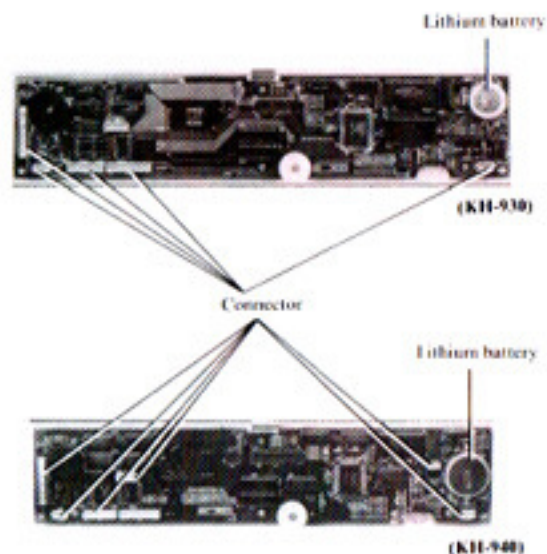

3. Raise the main P.C. board and remove the cable protection sheet. (Refer to picture 10-2)

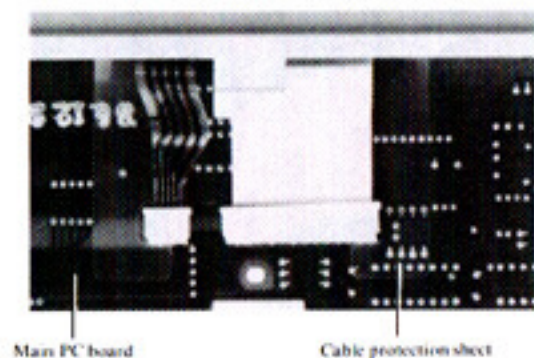

4. Release the connector locks connect for the flat cable and disconnect the flat cables (refer to Fig. 10-3). Then remove the main P.C. board from the pattern case whole unit.

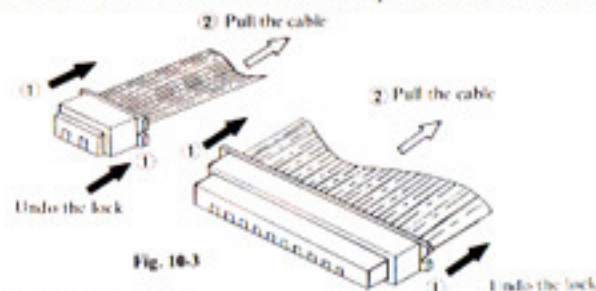

5. Replace the lithium battery

*In case of KH-940

- (a). Dissolve the solder on the + terminal side of the battery sufficiently with a solder iron. And pull up the + terminal side of the battery with your hand while the solder is in a liquid (refer to figure 10-4).

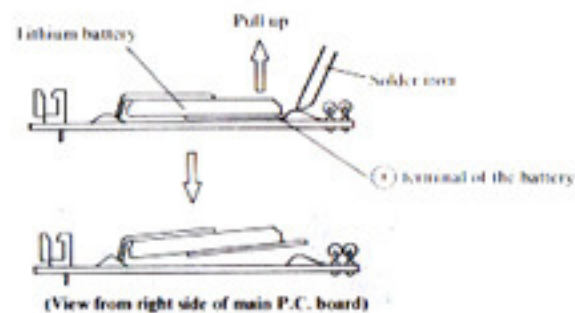

- (b). Dissolve the solder on the - terminal of the battery with a solder iron. And pull up the battery with your hand while the solder is in a liquid (refer to figure 10-5).

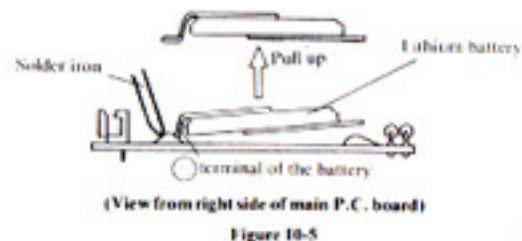

- (c). After that, remove the solder on the both patterns for soldering battery with the solder wick (for sponging up a solder), or the soldapullt (to remove a solder). (Refer to figure 10-6)

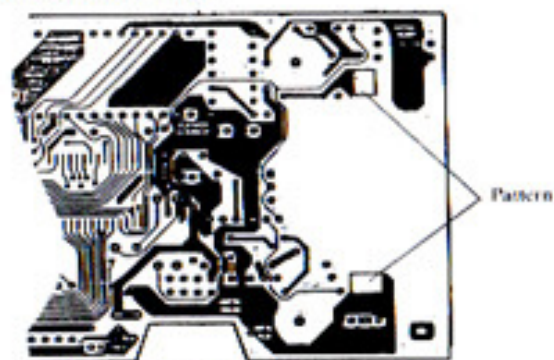
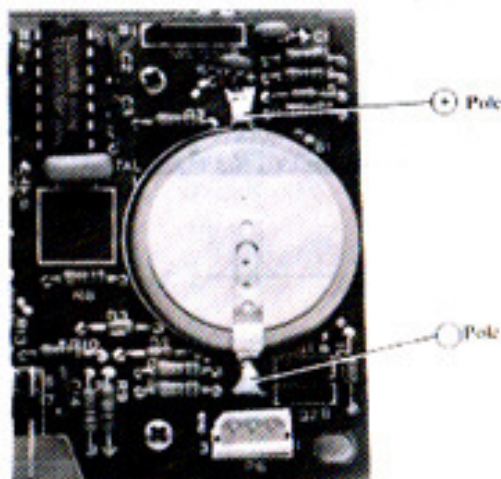

Figure 10-6

- (d). Put the new battery on the Pattern of the Main P.C. board and solder it.

*** CAUTION 1**

Please, watch the pole of the battery when you solder it (refer to picture 10-7).



Picture 10-7

***CAUTION 2**

Please, try to run TEST PROGRAM "888" in order to clear the memory (RAM) after assembling the pattern case whole unit.

***In case of KH-930**

- (a). Dissolve the solder on the + terminal side of the battery sufficiently with a solder iron. And pull up the + terminal side of battery with your hand while the solder is in a liquid (refer to figure 10-8).

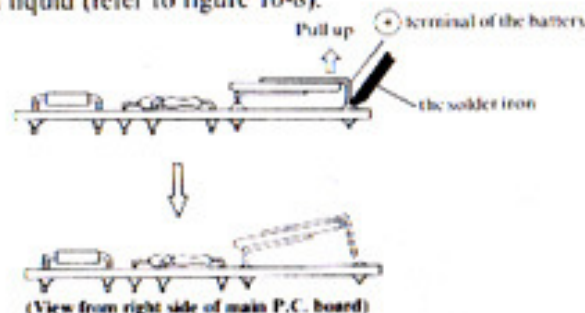

Figure 10-8

- (b). Turn over the main P.C. board and dissolve the solder on the - terminal of the battery with solder iron (refer to figure 10-9). Then pull down the battery with your hand while the solder is in a liquid.

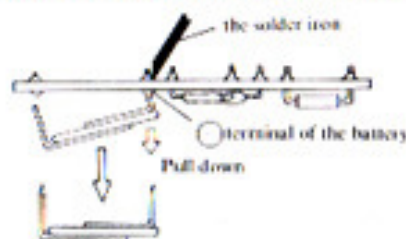
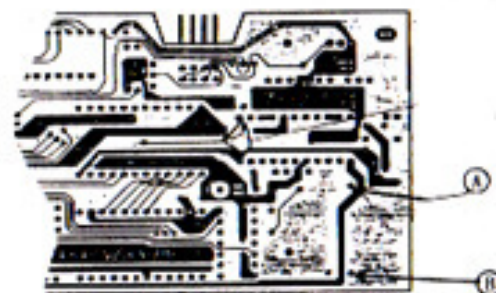

Figure 10-9

- (c). After that, remove the solder in the hole (A) and (B) in figure 10-10 with the solder wick (for sponging up a solder), or the soldapullt (to Remove a solder).



(View from reverse side of main P.C. board)

Figure 10-10

(d). Put the new battery into hole (C) and (D) in figure 10-11) and solder it.

***CAUTION 1**

Please, watch the pole of battery when you solder it (refer to figure 10-12).

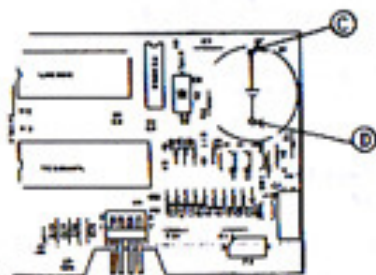

Figure 10-11



(View from right side of main P.C. board)

Figure 10-12

***CAUTION 2**

Please, turn on the power switch after replace the battery and the pattern case whole unit to the machine.

At this point, maybe "888" will blink in the display or without the blinking but the KH-930 does not accept the Key operation.

But in this case, that does not mean the trouble.

If, "888" blinks, take the way as item 11.1 (WHEN "888" BEGINS TO BLINK WITH POWER SWITCH ON) on page 27.

If, KH-930 does not accept the Key operation, wait until READY lamp light on (about 30 seconds to 60 seconds).

Then perform the TEST PROGRAM "888" in order to clear the memory (RAM).

10.2 Reassembly of the main P.C. board & the pattern case whole unit

- Undo the lock on the main P.C. board flat cable connector (P7, P8). (Refer to Figure 10-13)
- Next, connect the cables in to the connectors, and lock the connectors. (Refer to Figure 10-14)

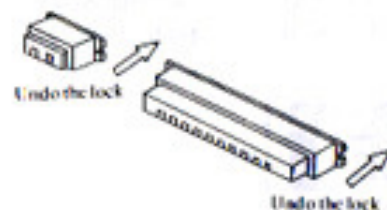

Figure 10-13

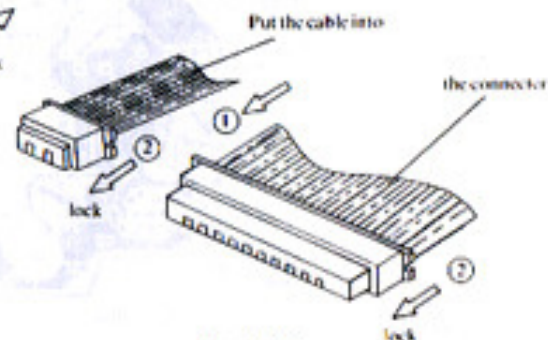

Figure 10-14

- Mount the cable protection sheet, after that assemble the main P.C. board to the operation panel and tighten the 6 tapping screws.

***CAUTION**

Please, be cautions to ensure that the volume dial for the Buzzer and connector for FBI00KM (P9) fit through their respective openings in the operation panel face.

- Connect all 6 of the connectors of the main P.C. board and mount the pattern case whole unit to the machine.

10.3 Removing the Operation PC Board

- ① Remove the Main P.C. Board from the pattern case whole unit.
- ② Remove the six operation PC board screws (refer to picture 10-15).
- ③ Push the shaft parts of operation PC board and remove the operation PC board from the operation panel (refer to picture 10-16).

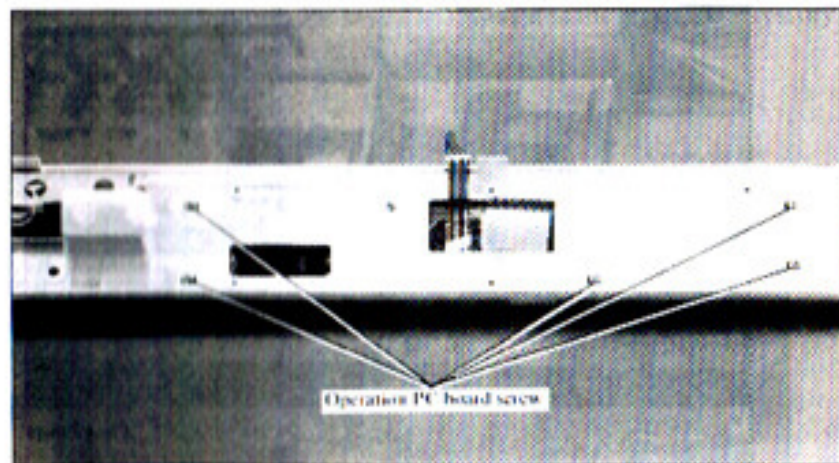

Picture 10-15



Picture 10-16

10.4 Reassembly of the Operation PC Board and the Main PC Board

1. Mounting the operation PC board (refer to figure 10-17)
 - ① With the operation PC board turned upside down, place the display window (filter) into the opening in the operation PC board
 - ② Next, place the operation panel over the operation PC board and put the screws in and tighten them (put the cable through the opening in the operation panel).

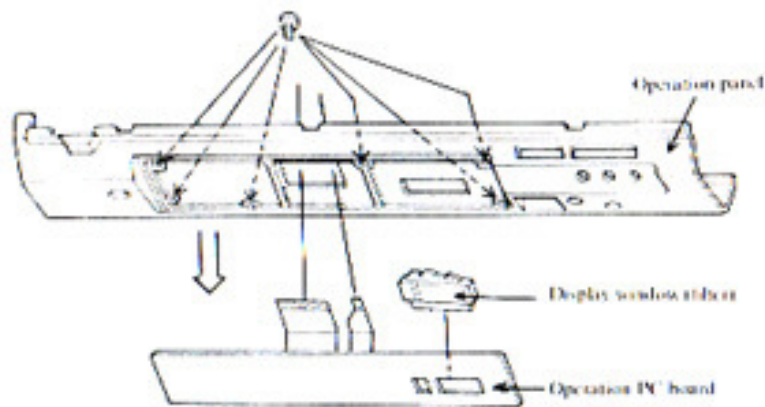

Figure 10-17

2. Reassembly of the main PC board
 - ① Undo the lock on the main PC board flat cable connector (P7, P8).
 - ② Next, plug the cable into the connector, and lock the connector.
 - ③ After mounting the cord protection sheet, assemble the main PC board to the operation panel and tighten the 6 tapping screws.

Note:

Be cautious to ensure that the volume (VRI) and the external memory device (FB100KM) connector (P9) fit through their respective openings in the operation panel face.

10.5 Removing the Encoder PC Board and the Slit Disc

- ① Remove the encoder PC board holder plate screws (refer to picture 10-18)
- ② Raise the encoder PC board straight up.
- ③ Remove both of the screws on each of the encoder PC boards.
- ④ Remove the two encoder PC boards from the encoder PC board holder plate.
- ⑤ Pull the needles near the slit disc toward you, and pulling the slit disc out toward the left, remove it from the rotary cam shaft (refer to picture 10-19).

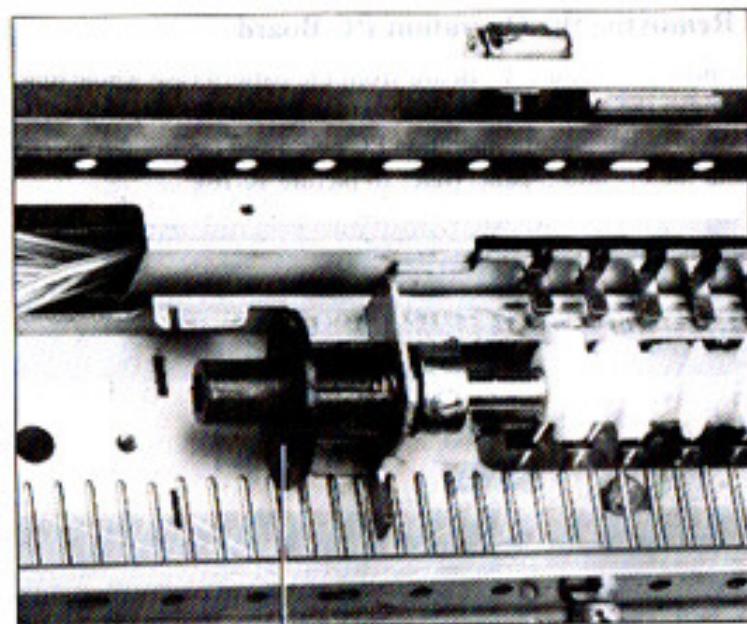
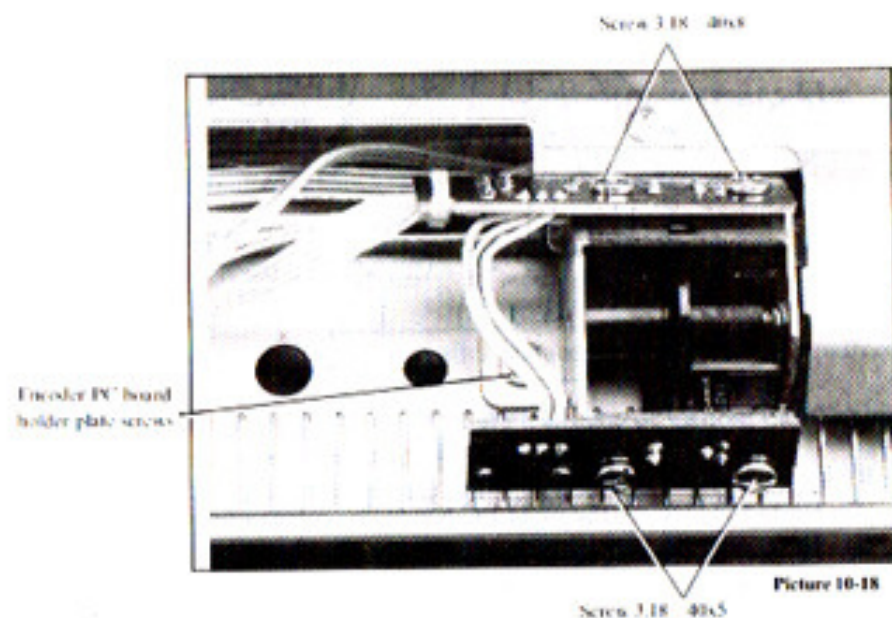

10.6 Removing the Power Supply PC Board

- ① Remove the operation panel and the accessory box (refer to 14.1 and 14.2).
- ② Cut the binder that holds the signal wires by stay center B.
- ③ Remove connector S10 from the power supply PC board.
- ④ Remove the two screws from the heat sinker of the power supply PC board (refer to picture 10-20).
- ⑤ Remove the power supply PC board by sliding it to the left of the accessory box setting plate.

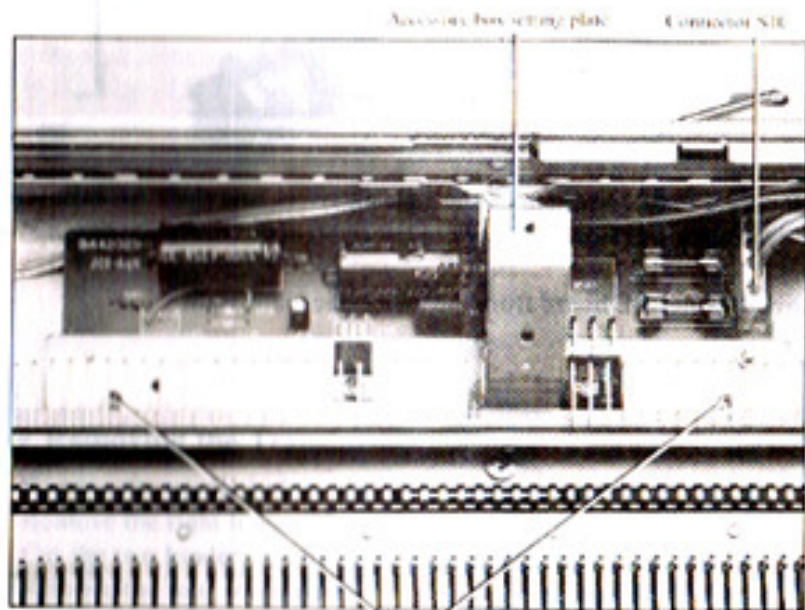

Power supply PC board screws

Picture 10-20

10.7 Removing the Left Position Sensor PC Board

- ① Cut the binder that holds the signal wires by stay center B.
- ② Remove the left position sensor PC board screws (refer to picture 10-21).

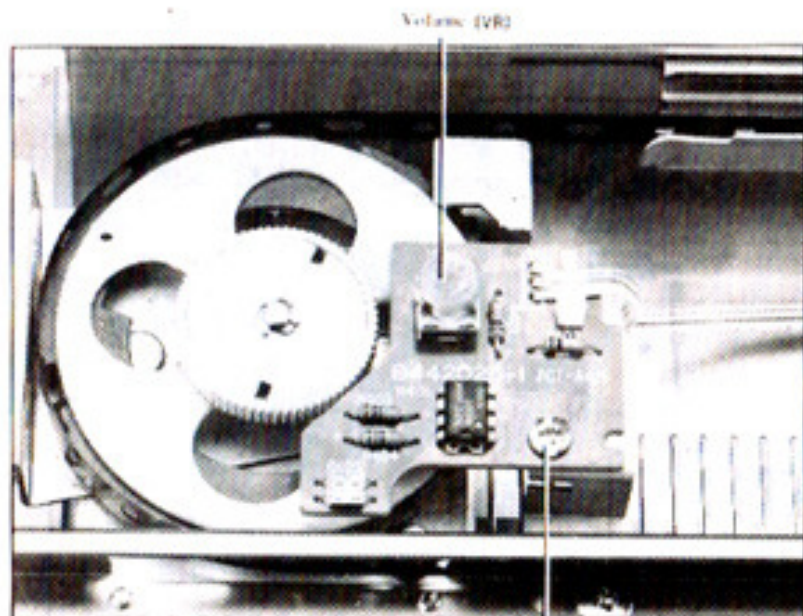

Left position sensor PC board screws

Picture 10-21

10.8 Removing the Right Position Sensor PC Board

- ① Remove the right position sensor PC board screws.
- ② Take the right position sensor PC board off toward you (refer to picture 10-22).

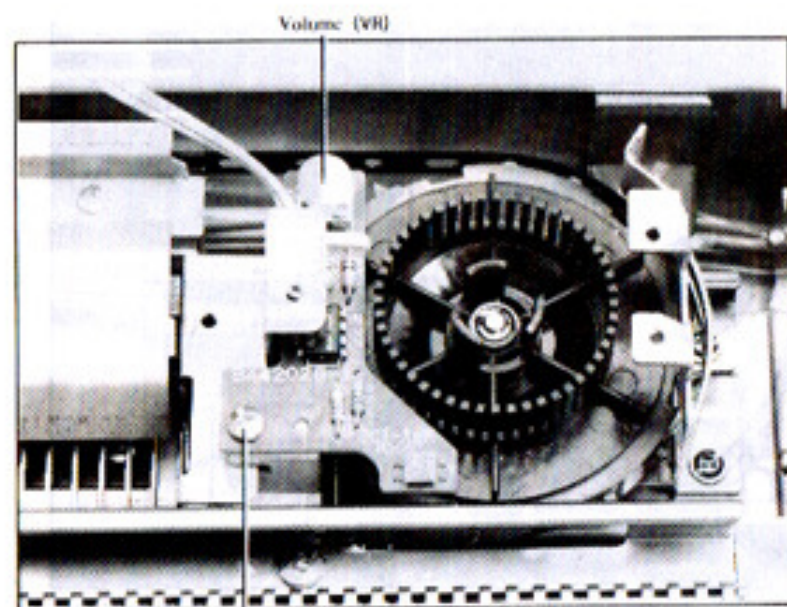

Right position sensor PC board screws

Picture 10-22

10.9 Removing the Filter PC Board

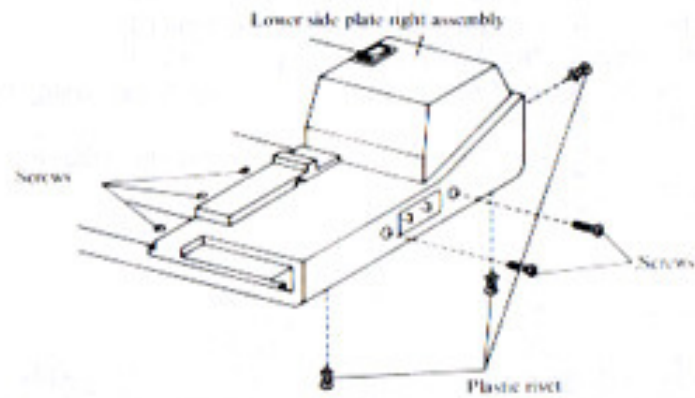

Figure 10-23

- ① Remove the 3 needle bed screws, the 3 plastic rivets, and the 2 AC inlet screws.
- ② Slide the right lower side plate toward the right, and remove the power switch from it.
- ③ Remove the filter PC board from the lower side plate, right.

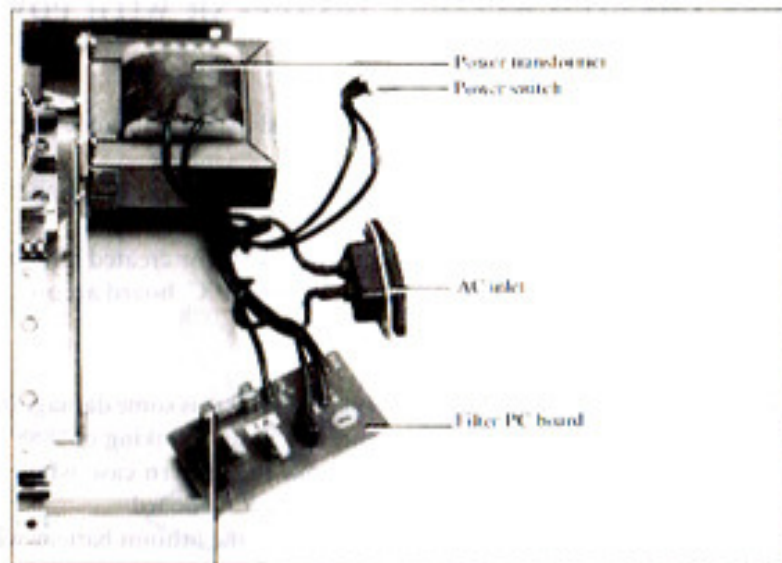

FIGURE 10-11

Picture 10-12

10.10 Removing the Transformer

- ① Remove the needle bed from the main body case (refer to chapter 14.1 on P. 49).
- ② Remove the right lower side plate.
- ③ Cut the two binders holding the transformer cord.
- ④ Remove the four transformer screws.

11. WHEN "888" BLINKS WITH THE POWER SWITCH ON (WITH KH-930) OR WHEN CREATED PATTERN DISAPPEAR WITH THE POWER SWITCH ON (WITH KH-940)

11.1 WHEN "888" BLINKS WITH THE POWER SWITCH ON

(* This happens only when using KH-930)

The READY lamp does not light up and "888" blinks on display when power switch is turned on.

In this case, The lithium battery is consumed up (the voltage is dropped less than DC 2.5V).

Or, there is something damage in memory (RAM) for created pattern.

So that, check both the lithium battery and the main P.C. board according to following steps.

- (a). At first, push the "STEP" key and the "INPUT" key simultaneously, and check the blinking "888" disappears.
At this point, the created data of the memory (RAM) will have been completely cleared.
- (b). Turn power switch off and take out pattern case whole unit without disconnecting the connectors on the main P.C. board.
Then measure the the voltage between terminals of the lithium battery with a circuit tester (refer to figure 11-1).

*CAUTION

Please, do not mistake the pole of battery when you measure the voltage with the Tester.

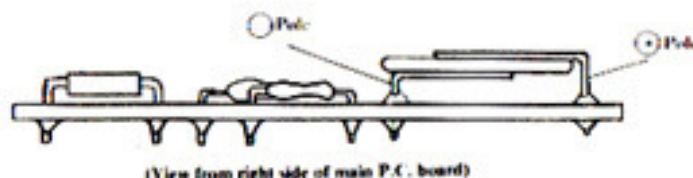

Figure 11-1

- (c). If, the voltage of battery is less than DC 2.5 (V), the battery is out of order.
So replace the battery according to item 10.1 (on page 20).
If the voltage of the battery is DC 2.5 (V) or more, the battery is normal.
Then, try the TEST PROGRAM "888" for checking the memory (RAM) circuit of created pattern (refer to item 6.3 on page 12).
If, "E" (an error) is indicated in the memo display, there is problem on the memory circuit so replace the main P.C. board.
If, "E" is not indicated in the TEST PROGRAM "888", there is no problem on the main P.C. board.

11.2 WHEN CREATED PATTERN DISAPPEAR WITH POWER SWITCH ON

(* This happens only when using KH-940)

"E" blinks in the memo display and the created pattern disappears when entering created pattern.

In this case, The lithium battery is consumed up (the voltage is dropped less than DC 2.5V).

Or, there is something damage in the memory (RAM) for created pattern.

So that, check both the lithium battery and the main P.C. board according to following steps.

*NOTE

In case of KH-940, if the battery is consumed up, or, there is some damage in the memory (RAM) which is cleared automatically without blinking of "888".

- (a). At first, turn off the power switch and take out the pattern case whole unit without disconnecting the connectors on the main P.C. board.
Then measure the DC voltage between terminals of the lithium battery with a circuit tester (refer to picture 11-2).

*CAUTION

Please, do not mistake the pole of battery when you measure the voltage with the Tester.

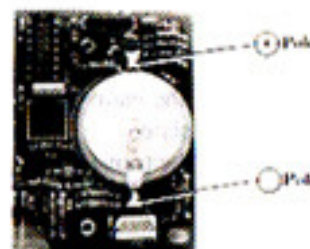

Picture 11-2

- (b). If, the voltage of battery is less than DC 2.5 (V), the battery is out of order.
So replace the battery according to item 10.1 (on page 19).
If the voltage of the battery is DC 2.5 (V) or more, the battery is normal.
Then, try the TEST PROGRAM "888" for checking the memory (RAM) circuit of created pattern (refer to item 6.3 on page 12).
If "E" (an error) is indicated in the memo display, there is problem on the memory circuit so replace the main P.C. board.
If "E" is not indicated in the TEST PROGRAM "888", there is no problem.

12. DISASSEMBLY, ASSEMBLY, AND ADJUSTMENT OF K CARRIAGE

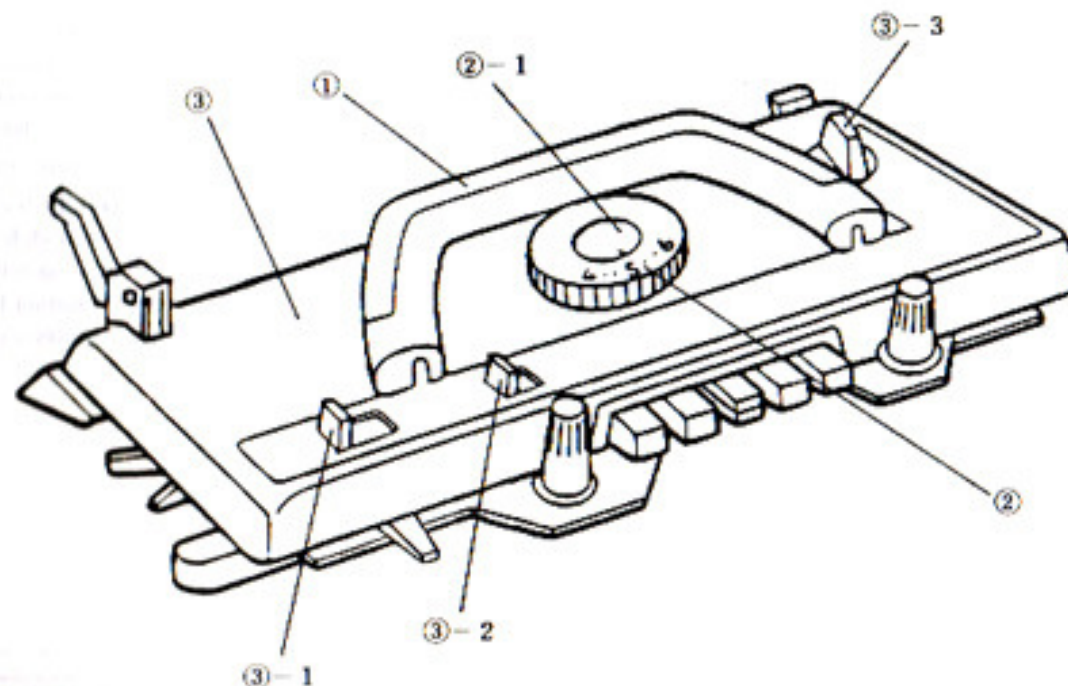

Part Nomenclature

- ① Carriage handle
- ② Stitch dial
- ②-1 Stitch dial cap
- ③ Carriage cover
- ③-1 H.C.L. knob
- ③-2 Plain lever knob
- ③-3 Change knob

12.1 Disassembling the K carriage

1. Removing the carriage handle

- 1.1 Keep the handle down and remove the two right and left handle screws. Then the handle can be taken off the carriage.

2. Removing the stitch dial

- 2.1 Pull off the stitch dial cap upward.

- 2.2 Remove the fastening screw and pull off the stitch dial upward.

3. Removing the carriage cover

- 3.1 Loosen, from the back of the carriage, and remove the two right and left carriage cover clamp screws (tapping screws).
- 3.2 Pull off the carriage cover upward. Then the H.C.L. knob, the plain lever knob and the change knob will come off.

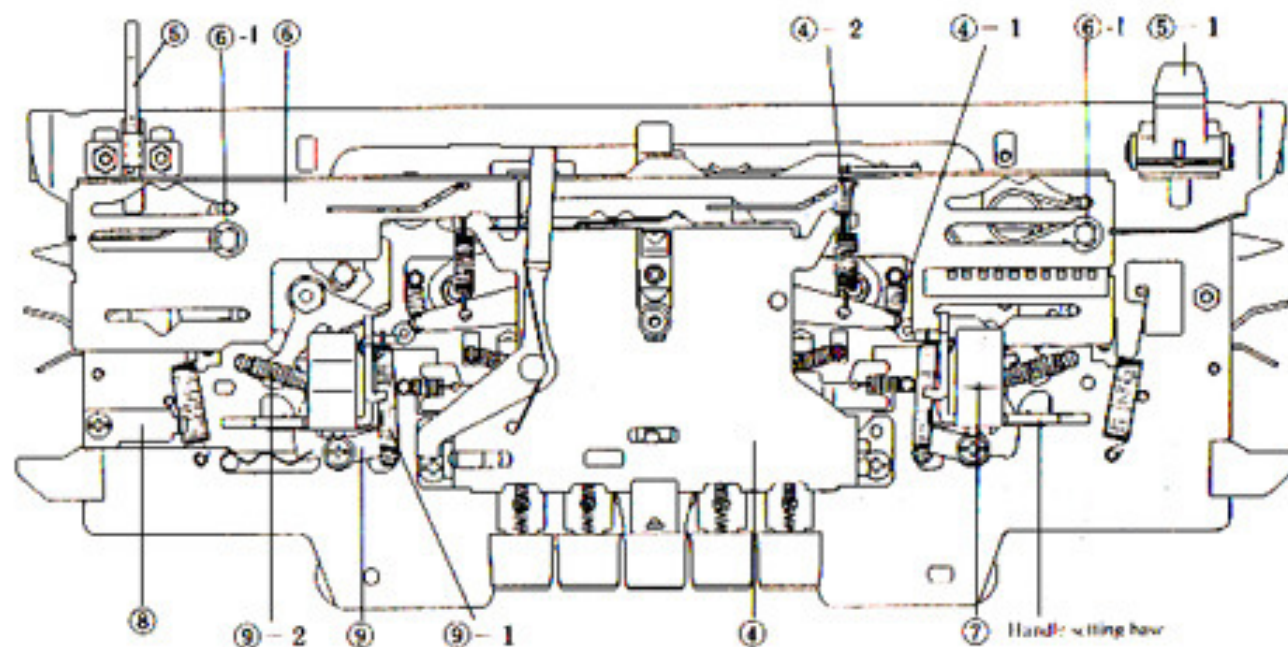

Part nomenclature

- ④ Cam button unit
- ④-1 Raising cam switch spring
- ④-2 Shift spring for K carriage sensor
- ⑤ Knit reader tripper
- ⑤-1 Row counter tripper
- ⑥ Upper slide plate
- ⑥-1 Snap ring
- ⑦ Handle lock spring
- ⑧ Front slide plate spring
- ⑨ Intarsia lever
- ⑨-1 Intarsia lever spring
- ⑨-2 Intarsia spring

4. Removing the cam button unit

- 4.1 Remove the raising cam switch spring from the cam button unit side.
- 4.2 Remove the shift spring for K carriage sensor from the K carriage sensor magnet.
- 4.3 Remove the two screws from the cam button unit, raise the cam button unit and separate the hammer in the screw section from the carriage plate, and pull it out toward you.

5. Removing the knit reader tripper and the row counter tripper

- 5.1 Remove the two screws from the knit reader tripper and the row counter tripper from the rear of the carriage.

6. Removing the upper slide plate

- 6.1 Remove the snap ring from the change knob shaft and the left side shaft.
- 6.2 Remove upper slide plate by lifting the left and right ends up at the same time.

7. Removing the handle lock spring

- 7.1 Remove the left and right handle lock spring screws from the handle setting base crimped onto the carriage plate.

8. Removing the front slide plate spring

- 8.1 Remove the front slide plate spring screws and take off the front slide plate spring.

9. Removing the intarsia lever

- 9.1 Remove the intarsia lever spring (remove the spring from the intarsia lever side).
- 9.2 Remove the intarsia spring.
- 9.3 Remove the right and left intarsia lever screws and the lever collar at the same time.
- 9.4 Turn over the intarsia lever then remove it from the gap between the handle setting base and the carriage plate.

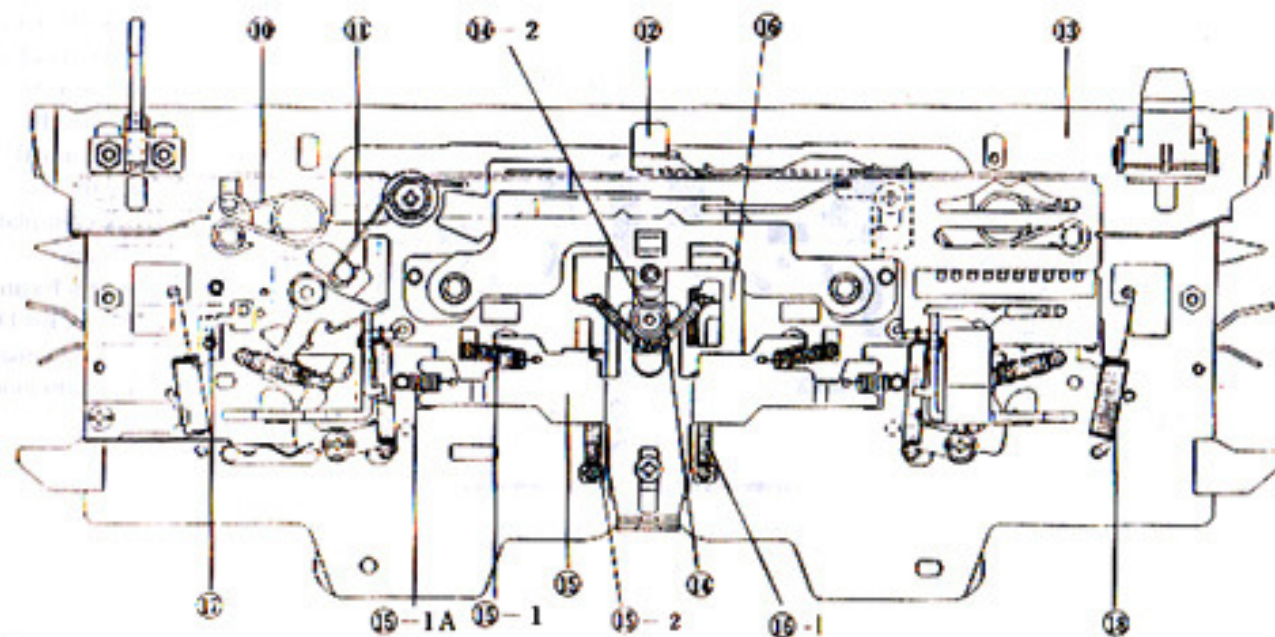

Part nomenclature

- ⑩ Connecting plate spring
- ⑪ Needle selection change spring
- ⑫ K carriage sensor magnet
- ⑬ Rear plate
- ⑭ Tuck cam spring
- ⑭-2 Tuck cam spring collar
- ⑮ Change plate A
- ⑮-1 MC cam spring
- ⑮-1A MC cam spring
- ⑮-2 Change plate A spring
- ⑯ Change plate B
- ⑯-1 Change plate B spring
- ⑰ End needle selection cam
- ⑱ Valve cam F spring

10. Removing the connecting plate spring

10.1 Lift and pull off left and right connecting plate springs.

11. Removing the needle selection change spring

11.1 Remove right and left needle selection change springs

12. Removing the K carriage sensor magnet

12.1 Take out the shaft for K carriage sensor magnet and remove the K carriage sensor magnet

13. Removing the carriage rear plate

13.1 Raise the carriage rear plate as it is and remove it.

14. Removing the tuck cam spring and presser ring collar

14.1 Remove the hooks on the two ends of the tuck cam spring from the tuck cam spring hook catches.

14.2 Remove the tuck cam spring collar from the stitch dial shaft.

15. Removing change plate A

15.1 Remove the four left and right MC cam springs and the four left and

right MC cam springs A from the cam side.

15.2 Remove the change plate A spring (black) from the carriage front foot side.

15.3 Remove the change plate guide collar and lift change plate A up and out.

16. Removing change plate B

16.1 Remove change plate B spring from the carriage front foot side.

16.2 Remove change plate B spring and lift change plate B up and out (as well as the stitch cam collar).

17. Removing the end needle selection spring

17.1 Remove the end needle selection spring from the pin crimping to the carriage plate.

18. Removing valve cam F spring

18.1 Remove valve cam F spring from valve cam F and the front slide plate set screw.

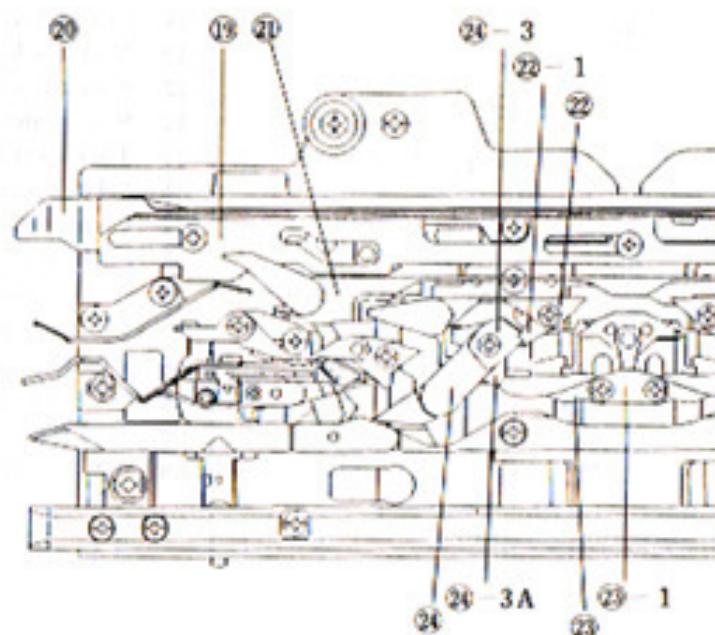

Carriage front side

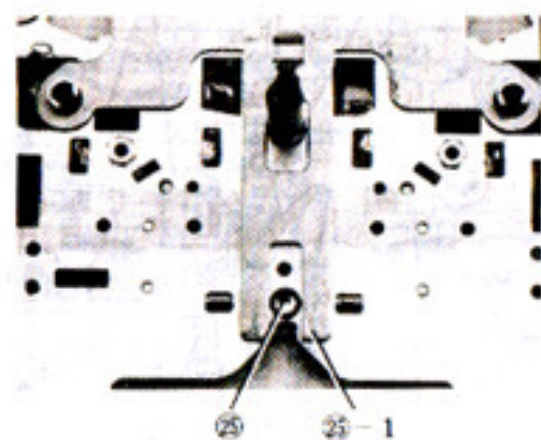

Part nomenclature

- 19 Front slide plate
- 20 Carriage front foot
- 21 Guide cam A
- 22 Guide cam B
- 22-1 Valve cam B
- 23 Tuck cam
- 23-1 Tuck cam plate
- 24 Stitch cam
- 24-3 Sub stitch cam
- 24-3A Valve cam D
- 25 Stitch cam collar
- 25-1 Stitch cam guide plate

***Carriage rear**

19. Removing the front slide plate

19.1 Remove the two set screws on the left and right and the one in the center of the front slide plate, and lift the front slide plate up and off.

20. Removing the carriage front foot

20.1 Remove the two carriage front foot clamp screws and then the foot itself.

21. Removing guide cam A

21.1 Remove the two left and right guide cam A clamp screws and then the cam itself (slide cam as well).

22. Removing guide cam B and valve cam B

22.1 Remove the left guide cam B screw as well as the left valve cam B screw and remove the left guide cam B (as well as the left valve cam B, the left valve cam B spring, and valve cam B shaft). Remove the right guide cam B in a similar way (as well as the slide cam guide).

23. Removing the tuck cam

23.1 Remove the tuck cam plate screws and remove the tuck cam plate and the tuck cam (as well as the washer and the tuck cam shaft).

24. Removing the stitch cam

24.1 Remove the snap ring on the left and right stitch cam shaft from the front side of the carriage.

24.2 Remove the nut from the sub stitch cam from the front side of the carriage.

24.3 Remove the left stitch cam clamp screw, and the left sub stitch cam, the left stitch cam, the left valve cam D, the left valve cam D spring, the sub stitch cam shaft, and the left MC cam will all come off.

24.4 Remove the right stitch cam in a similar way.

25. Removing the stitch cam guide plate

25.1 When the snap ring E7 on the left and right of the stitch cam shaft and the left and right raising cam guides are removed, the stitch cam collar and the stitch cam guide plate will come off.

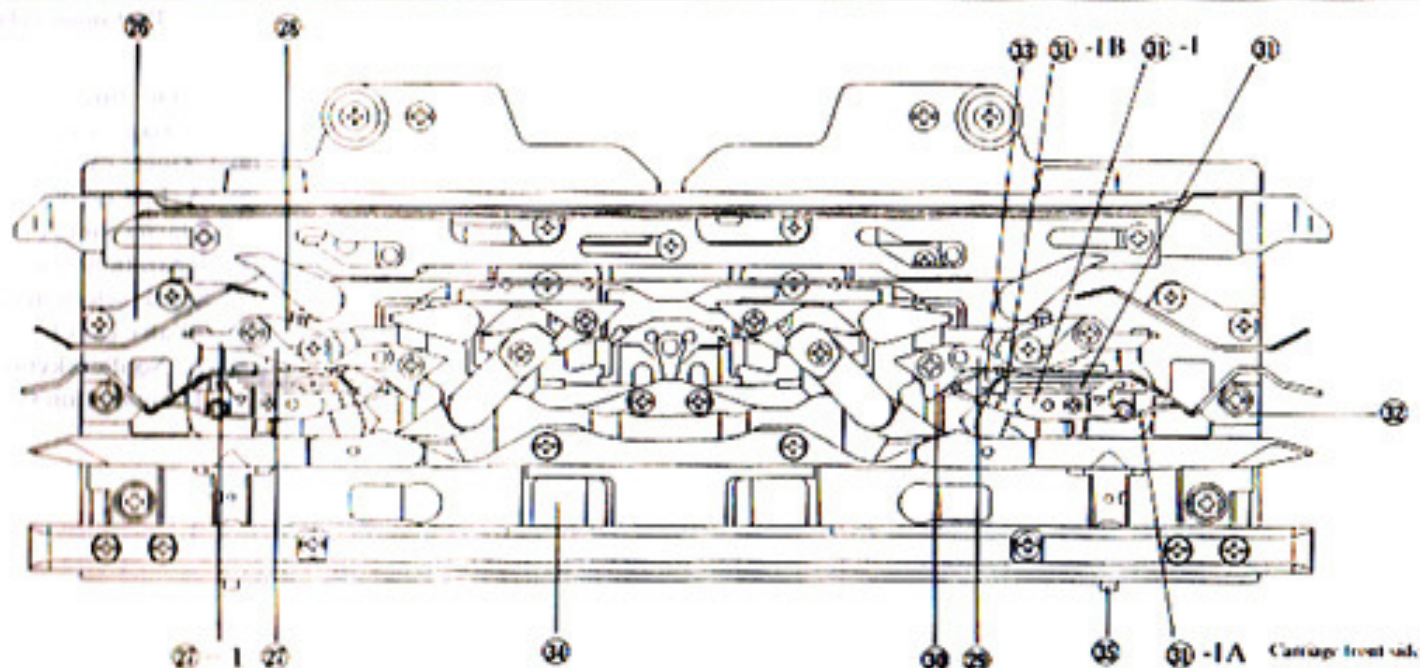

Part nomenclature

- 26 Guide cam F
- 27 Intarsia cam B
- 27-1 Intarsia cam B plate
- 28 Sub selection cam
- 29 Valve cam G
- 30 Cam plate
- 31 Needle selection cam
- 31-1 Guide cam G
- 31-1A Valve cam F
- 31-1B Needle selection change cam
- 32 Separation cam
- 33 Intarsia cam A
- 34 Carriage rear foot
- 35 Connecting plate

26. Removing guide cam F

26.1 Remove the left and right guide cam F clamp screws, and the left and right guide cam F will come off.

27. Removing the intarsia cam B and intarsia cam B plate

27.1 Remove the left and right intarsia cam B plate clamp screws, and the left and right intarsia cam B plate, left and right intarsia cam B, left and right intarsia cam B springs, and intarsia cam B shaft will come off.

28. Removing the sub selection cam

28.1 Remove the left and right sub selection cam screws, and the left and right parts of the sub selection cam will come off.

29. Removing valve cam G

29.1 Remove the left and right valve cam G shaft, snap ring E2, and plain washer 3.5 from the front side of the carriage.

29.2 Remove the left and right valve cam G on the back side of the carriage from the valve cam G spring left and right spring catches, and lift valve cam G up and off.

30. Removing the cam plate

30.1 Remove the cam plate screws and take the cam plate off (the valve cam G spring will also come off).

31. Removing the needle selection cam

31.1 Remove the guide cam G screws, and guide cam G, valve cam F, the needle selection change cam, and the needle selection cam will come off.

32. Removing the separation cam

32.1 Remove the nuts of the screws on the separation cam from the front side of the carriage.

32.2 Remove the separation cam screws, and the separation cam will come off.

33. Removing the intarsia cam A

33.1 Loosen both the intarsia cam A nuts from the front side of the carriage and the needle selection cam shaft from the rear side of the carriage and remove them.

33.2 Remove the intarsia cam A forward from the carriage plate hole.

34. Removing the carriage rear foot

34.1 Remove the six carriage rear foot screws, and the carriage rear foot will come off.

34.2 Remove the end needle selection cam, guide cam C, and the guide cam C spring.

35. Removing the connecting plate

35.1 Pull off the connecting plate by lifting it by its right and left parts near the front foot.

Part nomenclature

- ① Connecting plate
- ② Carriage rear foot
- ②-1 Guide cam C
- ②-1A End needle selection cam
- ③ Intarsia cam A
- ④ Separation cam
- ⑤ Needle selection cam
- ⑤-1 Valve cam F
- ⑤-1A Needle selection change cam
- ⑤-1B Guide cam G

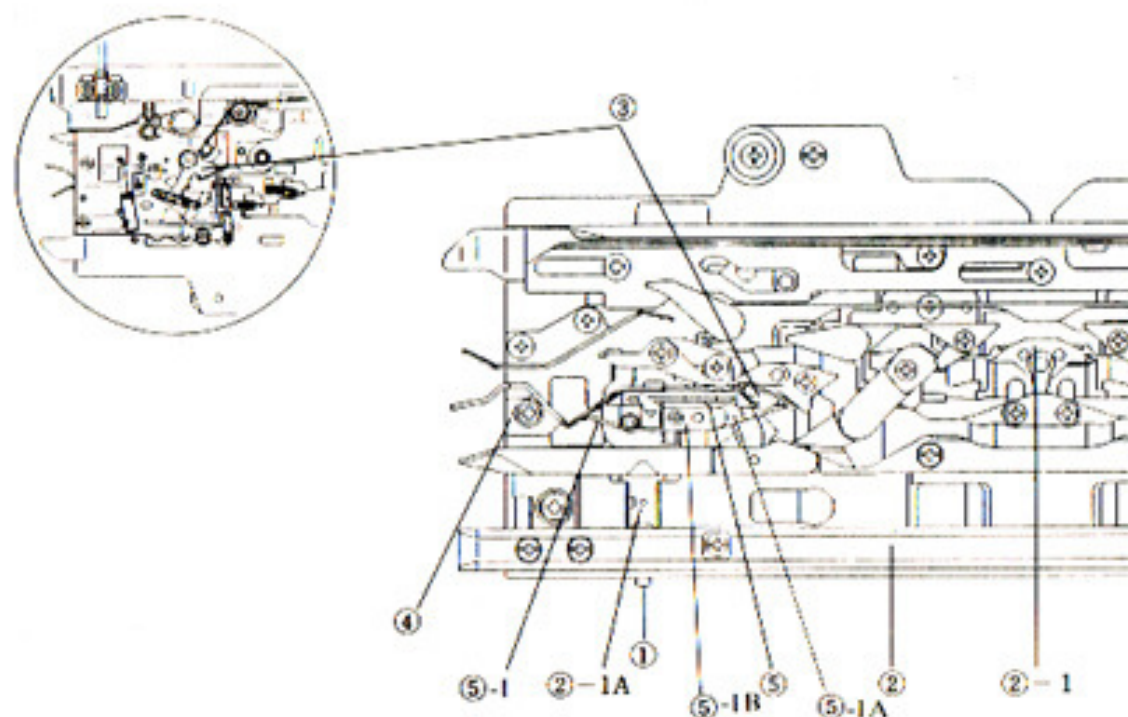

12.2 Assembling the K carriage

1. Mounting the connecting plate

1.1 Fit the left and right connecting plate into the carriage plate.

2. Mounting the carriage rear foot

2.1 Place the guide cam C spring on guide cam C and place guide cam C in the center of the carriage. After mounting the left and right end needle selection cam, mount the carriage rear foot and tighten the screws.

3. Mounting the intarsia cam A

3.1 Place the needle selection cam shaft in from the rear side of the carriage then place the left and right intarsia cam A in from the front side of the carriage. Secure the needle selection cam shaft and tighten the intarsia cam A nuts.

4. Mounting the separation cam

4.1 Mount the left and right separation cam with the screws (stud screws) and tighten the nuts on from the front side of the carriage.

5. Mounting the needle selection cam

5.1 Mount the valve cam F and the needle selection change cam and check the positioning of the needle selection cam. When this has been mounted, tighten the screws onto both this and guide cam G.

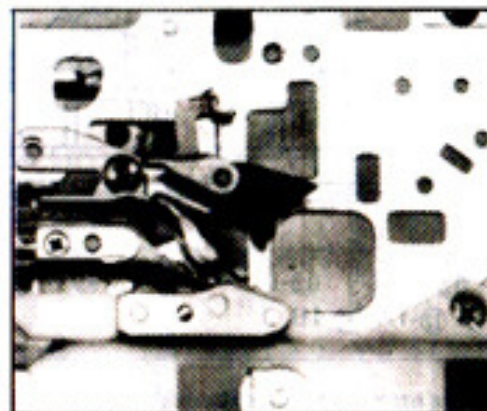
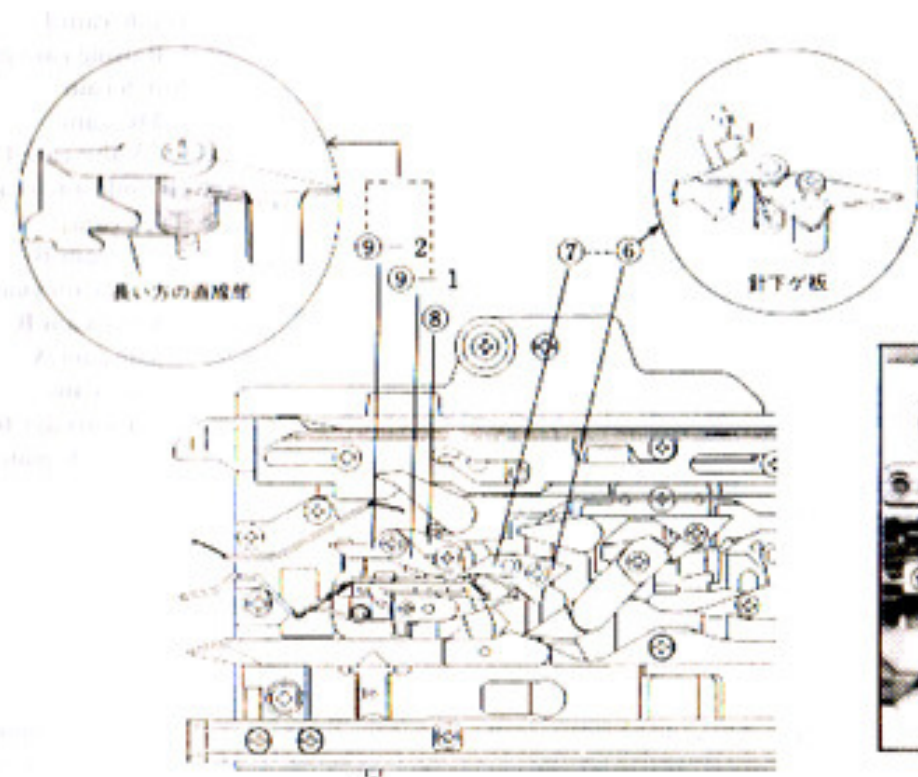

Part nomenclature

- ⑥ Cam plate
- ⑦ Valve cam G
- ⑧ Sub selection cam
- ⑨-1 Intarsia cam B
- ⑨-2 Intarsia cam B plate

6. Mounting the cam plate

- 6.1 Fit left and right valve cam G springs to the valve cam G shaft crimped onto the rear of the carriage.
- 6.2 Check the directional orientation of the cam plate and assemble it to the shaft, then tighten the cam plate screws.

7. Mounting valve cam G

- 7.1 Fit the valve cam G screw while holding the valve cam G spring over the cam plate.
- 7.2 Put the washer in from the front of the carriage and secure it with the snap ring E2.

8. Mounting the sub selection cam

- 8.1 Push the sub selection cam onto the selection cam side. When this is done, put only one screw in (looking from directly above the rear of the carriage, sub selection cam tip should always be hidden by the intarsia cam A).

9. Mounting the intarsia cam B and the intarsia cam B plate

- 9.1 Pass the intarsia cam B shaft through the intarsia cam B spring and the intarsia cam B.
- 9.2 Place the shaft on the sub selection cam and tighten it and the intarsia cam B plate with screws (in such a way that the longer of the intarsia cam B spring stems is against the intarsia cam B plate).

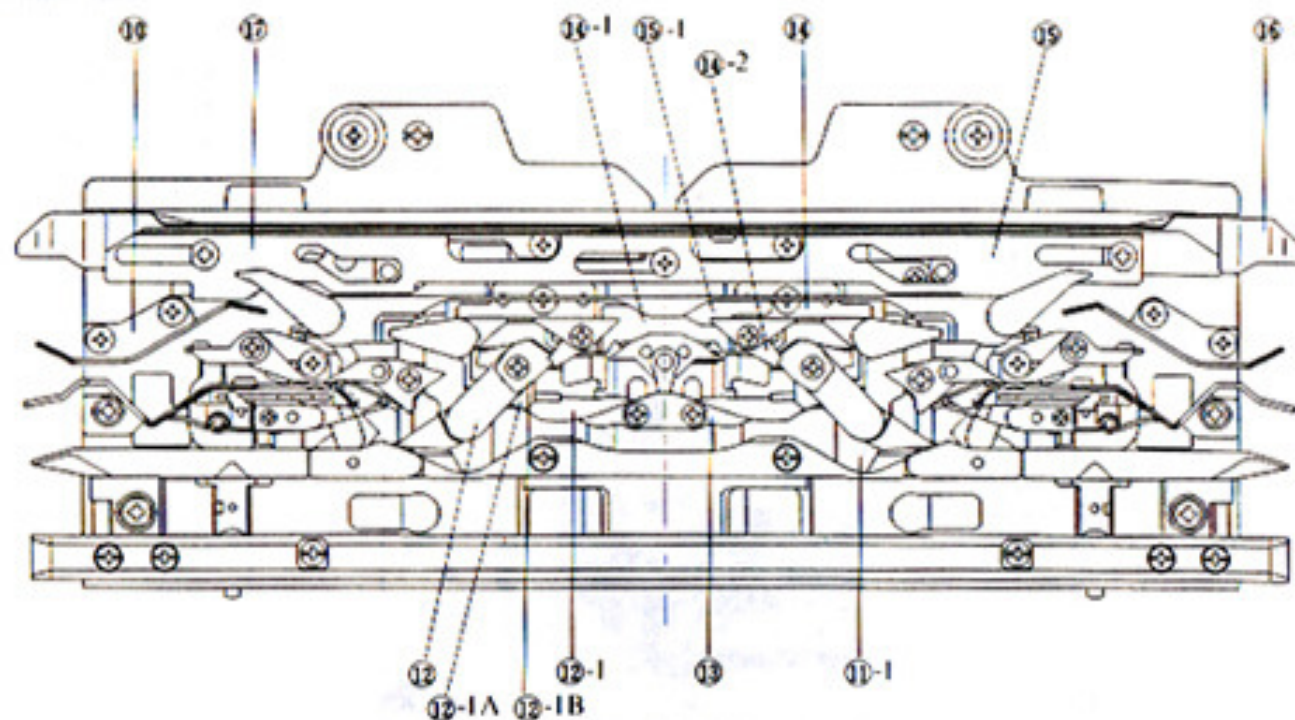

Part nomenclature

- ⑩ Guide cam F
- ⑩-1 Raising cam guide
- ⑪ Stitch cam
- ⑪-1 MC cam
- ⑪-1A Valve cam D
- ⑪-1B Sub stitch cam
- ⑫ Tuck cam
- ⑬ Guide cam B
- ⑬-1 Slide cam guide
- ⑬-2 Valve cam B
- ⑭ Guide cam A
- ⑭-1 Slide cam
- ⑮ Front carriage foot
- ⑯ Front slide plate

10. Mounting guide cam F

10.1 Mount and tighten the two screws of guide cam F.

11. Mounting the stitch cam guide plate

11.1 Mount the stitch cam guide plate from the front side of the carriage. Pass the stitch cam guide plate shaft through the right and left raising cam guide from the rear side of the carriage. Fasten it down with snap ring E7. *Ensure that the tip of the raising cam guide enters the carriage plate and is secured.

12. Mounting the stitch cam

12.1 Fit the MC cam, the sub stitch cam shaft, the valve cam D spring, valve cam D, the stitch cam, and the sub stitch cam, in that order, to the carriage plate and tighten it all down with a screw. Ensure that valve cam D functions with its spring.

13. Mounting the tuck cam

13.1 Fit the tuck cam shaft, the left and right tuck cam, the tuck cam washer, and the tuck cam plate, in that order, to the top of guide cam C and tighten it all down with a screw.

14. Mounting guide cam B and valve cam B

14.1 Insert the slide guide into the carriage plate.

14.2 Fit the valve cam B spring, the valve cam B shaft, valve cam B, and guide cam B, in that order, onto the top of the slide cam guide and tighten the valve cam B screw.

14.3 Tighten the screws on the right and left guide cam B. Valve cam B is on the inside of the sub stitch cam and should function with the spring spring.

15. Mounting guide cam A

15.1 Fit the slide cam to the slide cam guide.

15.2 Tighten the two screws on the right and left of guide cam A (such that the cam slides easily).

16. Mounting the front carriage foot

16.1 Tighten the front carriage foot on with the two screws.

17. Mounting the front slide plate

17.1 Put the front slide plate on top of the front carriage foot and tighten it on with 2 screws on the right and left and one screw in the middle.

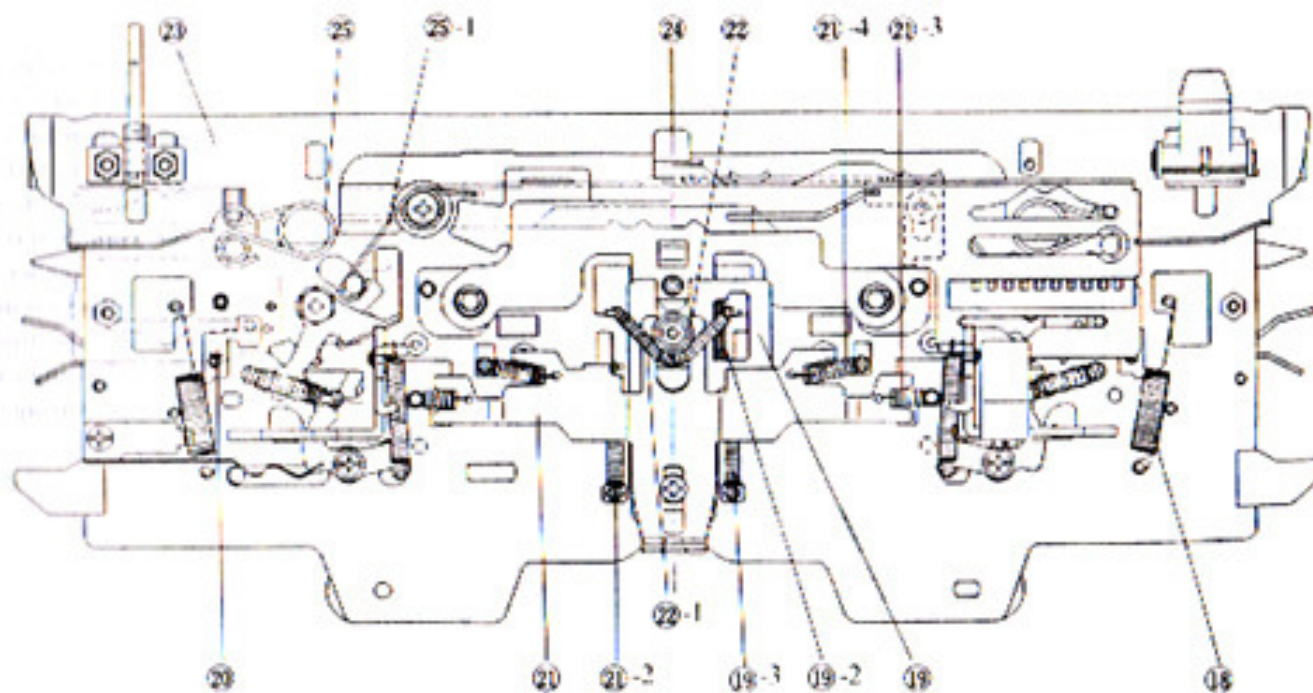

Part Nomenclature

- 18 Valve cam F spring
- 19 Change plate B
- 19-2 Change plate spring
- 19-3 Change plate B spring
- 20 End needle selection cam spring
- 21 Change plate A
- 21-2 Change plate A spring
- 21-3 MC cam spring
- 21-4 MC cam spring A
- 22 Tuck cam collar
- 22-1 Tuck cam spring
- 23 Carriage rear plate
- 24 K carriage sensor magnet
- 25 Connecting plate spring
- 25-1 Needle selection change spring

18. Mounting the valve cam F spring

18.1 Hook the valve cam F spring to the screw protruding from the carriage front foot and valve cam F.

19. Mounting change plate B

19.1 Put the stitch cam plate collar on the stitch cam plate groove.

19.2 While inserting the change plate spring, mount the dial shaft to change plate B.

19.3 Hook the change plate B spring to the carriage front foot.

20. Mounting the end needle selection cam spring

20.1 Hook the end needle selection cam spring over the end needle selection cam.

21. Mounting change plate A

21.1 Fit change plate A to the dial shaft and tighten the change plate guide collar in such a way that it passes through the stitch cam plate collar.

21.2 Hook the change plate A spring to the carriage front foot.

21.3 Hook the left and right MC cam spring and the left and right MC cam spring A onto their respective pins.

22. Mounting the tuck cam spring

22.1 Mount the tuck cam spring collar from the top of the dial shaft.

22.2 Hook the tuck cam spring onto the tuck cam. Hook it on in such a way that at the side with the change plate B spring, the opening part of hook of the tuck cam spring should be downside.

23. Mounting the carriage rear plate

23.1 Set the carriage rear plate.

24. Mounting the K carriage sensor magnet

24.1 Mount the K carriage sensor magnet with the K carriage sensor magnet shaft.

25. Mounting the connecting plate spring and needle selection change spring

25.1 Hook the connecting plate spring to the connecting plate calking pin and the change knob shaft.

25.2 Place the U shaped needle selection change spring over the needle selection change cam calking pin and over the K carriage sensor magnet shaft.

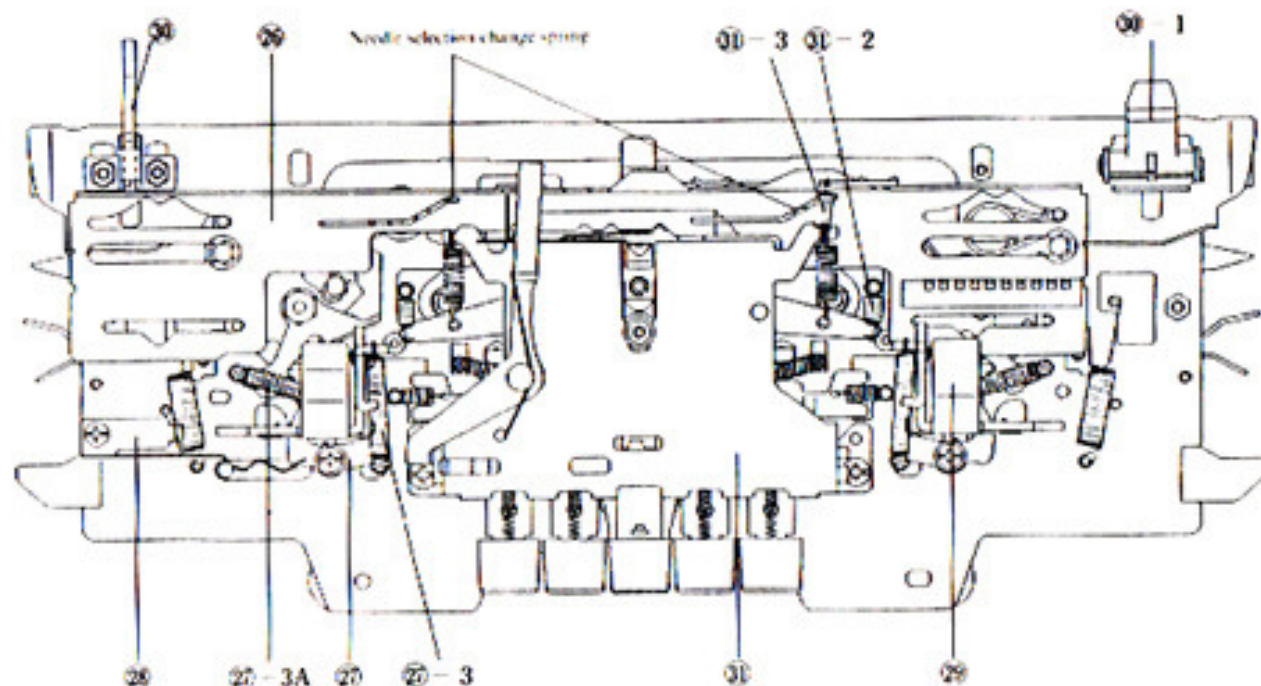

Part nomenclature

- ⑳ Upper slide plate
- ㉑ Intarsia lever
- ㉑-3 Intarsia lever spring
- ㉑-3A Intarsia cam A spring
- ㉒ Front slide plate spring
- ㉓ Handle screw
- ㉔ Knit reader tripper
- ㉔-1 Row counter tripper
- ㉕ Cam button unit
- ㉕-2 Raising cam switch spring
- ㉕-3 K carriage sensor shift spring

26. Mounting the upper slide plate

- 26.1 Mount the upper slide plate and then insert the carriage plate calking pin, the change knob shaft, the left and right connecting plate calking pins, the left and right separation cam calking pins and left and right needle selection change spring into the long hole on the upper slide plate.
- 26.2 Fix the upper slide plate onto the carriage plate calking pin and the change knob shaft with a snap ring.

27. Mounting the intarsia lever

- 27.1 Turn over the intarsia lever insert it into the gap between the handle setting base and the carriage plate (perform this operation opposite of the disassembly sequence).
- 27.2 Tighten the intarsia lever collar and intarsia lever A screws, in that order.
- 27.3 Mount the intarsia lever spring and intarsia cam A spring.

28. Mounting the front slide plate spring

- 28.1 Tighten the front slide plate spring screws in such a way that there is pressure on the front slide plate pin.

29. Mounting the handle screws

- 29.1 Tighten the handle spring screws onto the handle setting base.

30. Mounting the knit reader tripper and row counter tripper

- 30.1 Place the knit reader tripper on the left and the row counter tripper on the right and tighten each of them from the rear side of the carriage with two screws.

31. Mounting the cam button unit

- 31.1 Mount the cam button unit to the stitch dial shaft and tighten the left and right sides with screws.
- 31.2 Hook the raising cam change spring to the raising cam calking pin.
- 31.3 Mount the K carriage sensor shift spring to the K carriage sensor magnet.

Part nomenclature

- ③② Carriage cover
- ③②-1 H.C.L. knob
- ③②-2 Plain lever knob
- ③②-3 Change knob
- ③③ Stitch dial
- ③③-2 Stitch dial cap
- ③④ Carriage handle

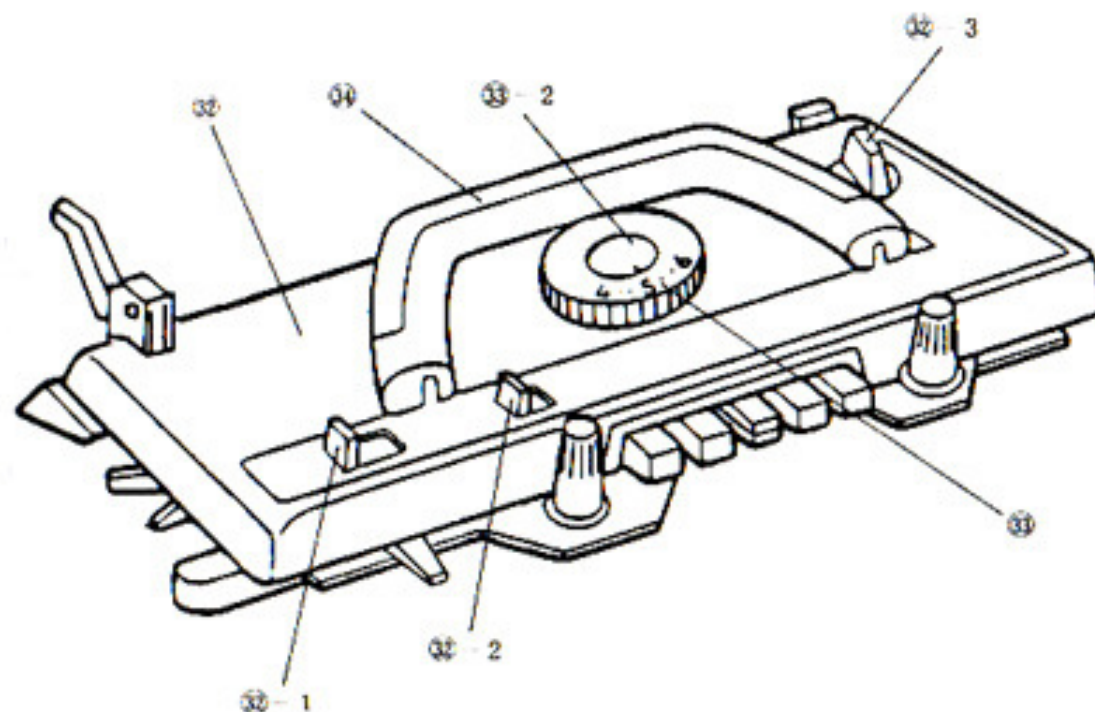

32. Mounting the carriage cover

- 32.1 Place the H.C.L. knob over the H.C.L. knob shaft.
- 32.2 Place the plain lever knob over the cam button unit.
- 32.3 Place the change knob over the change knob shaft (pay attention to the position).
- 32.4 Mount the carriage cover and tighten it down with screws (tapping screws) from the rear of the carriage.

33. Mounting the stitch dial

- 33.1 Fit the stitch dial on the shaft and tighten the screws in such a way that the notch in the stitch dial presser cap comes in front.
- 33.2 Bring the mark of the stitch dial presser cap to the notch in the knob retainer and put the cap in position. Align the line mark such that it is directly over the digits on the dial.

34. Mounting the carriage handle

- 34.1 Placing the handle in the down position, tighten it down on the left and right with screws.

12.3 Functional Check of the K Carriage

1. Functioning of the change knob

1.1 Switch the change knob from <N.I.> to <KC(I)> to <KC(II)> to <CR>, ensuring that each operates smoothly and that the left and right connecting plates, sensor magnets, left and right separation cams, left and right needle selection change cams, and the carriage rear plate make the switch properly.

2. Functioning of the MC cam

2.1 Without pushing the cam button, push the tips of the left and right MC cam up as far as they will go, and then help them down slowly with your fingers, ensuring that the left and right MC cam are returned properly to their original positions by the pressure of the spring.

2.2 Without pushing the cam button, check to ensure that the left and right tips of the MC cam are in proper contact with the tuck cam plate.

3. Functioning of the raising cam

3.1 Push the tips of the left and right raising cam as far as they will go setting the knitting dial scale (0 - 5 - 10) and, helping them down slowly with your fingers, ensure that the left and right raising cams are returned properly to their original positions by the pressure of the spring.

4. Functioning of the needle selection change cam

4.1 With the change knob in the <KC(II)> or <KC(I)> position, push the tips of the left and right needle selection change cam up as far as they will go, and, helping them down slowly with your fingers, they ensure that the left and right needle selection change cams are returned properly to its original positions by the pressure of the spring.

6. Functioning of the separation cam

5.1 With the change knob in the <KC(II)> position, ensure that the left and right separation cam are separated from the selection cam by the pressure of the spring.

5.2 With the change knob in the <KC(I)> position, ensure that the left and right separation cam are moved toward the needle selection cam and are within 0.5 mm of it.

6. Functioning of the tuck cam

6.1 With the left and right tuck cam buttons pushed, push the left and right tips of the tuck cam up as far as they will go, and, helping them down slowly with your fingers, ensure that the left and right tuck cam are returned properly to their original positions by the pressure of the spring.

6.2 Put the cam button in the <N> position, and, with the tips of the left and right tuck cam pushed all the way down, ensure that the left and right tuck cam are returned properly to their original positions by the pressure of the spring.

7. Functioning of the intarsia cam B

7.1 Push the tip of the intarsia cam B up and slowly let it down with your fingers. Ensure that the pressure of the spring properly makes the tip of the intarsia cam B contact the side face of the sub selection cam as it comes down.

8. Functioning of the intarsia lever

8.1 Ensure that the tip of the intarsia cam A properly contacts the carriage rear foot when the H.C.I. knob is put on the <I> position.

8.2 Push the tip of the intarsia cam A up with your fingers and let it down again slowly. Ensure that the tip of the intarsia cam A is returned properly to its original position by the pressure of the spring as it comes down.

9. Functioning of each of the valve cams

9.1 Rotate the tip of each of the valve cams with your fingers. Ensure that when you return them slowly with your fingers, the tip of each of the valve cams is properly returned by the pressure of the spring to its original position.

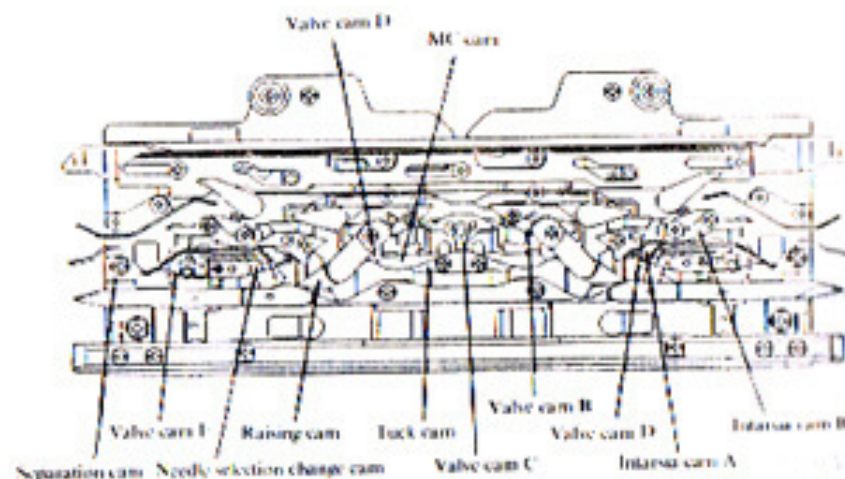

Figure 12-1

10. Functioning of the cam button unit

- 10.1 Switch the cam button from <TUCK> left and right, <MC>, <L>, and <PART> left and right, ensuring that the cam button unit operates smoothly and that left and right tuck cams, left and right MC cams, left and right MC change cams, guide cam C, and left and right raising cams switch properly.
- 10.2 With any one of the cam buttons pushed down, switch the change knob over from <KC(I)> or <KC(II)> to <N.I.>, ensuring that the cam button returns automatically.
- 10.3 With the sinker plate installed to the carriage, press the <I> button, ensuring that the yarn presser brush on the sinker plate switches properly.

11. Functioning of the H.C.I. knob

- 11.1 Switch the H.C.I. knob to <N> and <H>, ensuring that operation is smooth and that left and right change cams properly make the switch.
- 11.2 Ensure that the H.C.I. knob, when switched from <N> to <H>, stops at the <H> position properly.
- 11.3 While pushing the H.C.I. button, from the <H> position, ensure that the switch to <I> is made smoothly.
- 11.4 Ensure that the tip of the intarsia cam A makes proper contact with the carriage rear foot, and that valve cam G jumps up properly when switching over from <N> and <H> to <I>.
- 11.5 Ensure that when switching from <I> to <N> and <H>, the tip of the intarsia cam A properly contacts the cam plate, and that the tip of valve cam G contacts the sub selection cam.

12. Functioning of the plain lever knob

- 12.1 Push the <TUCK> left and right, <MC>, <L>, and <PART> left and right cam buttons, ensuring that when the plain lever knob is switched, operation is smooth and that the cam button returns properly to its original position.

12.4 How to Adjust the K carriage

1. Front and rear adjustment of the sinker plate

- 1.1 Mounting dimensions of the sinker plate The proper distance of the sinker plate from the rear carriage foot is 118.5 mm. If this distance is out of specification, adjust it by loosening the six screws to the left or right of the sinker plate.
- 1.2 Mounting dimensions of the yarn feeder The yarn feeder should be 120.5 mm from the rear carriage foot.

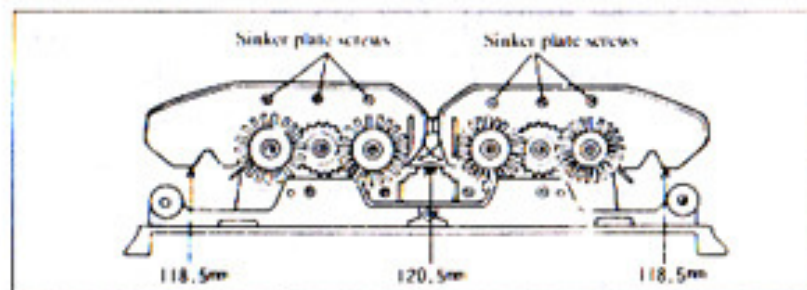

Figure 12-2

2. Vertical adjustment of the sinker plate

- 2.1 Place the carriage over the needle bed and put the H.C.I. knob on <H>.
- 2.2 Extend about five knitting needles to position E from three different places on the left, center, and right of the needle bed.
- 2.3 Bend the sinker plate to adjust it to make the gap between it and the knitting needle stem to within 0.5 mm.

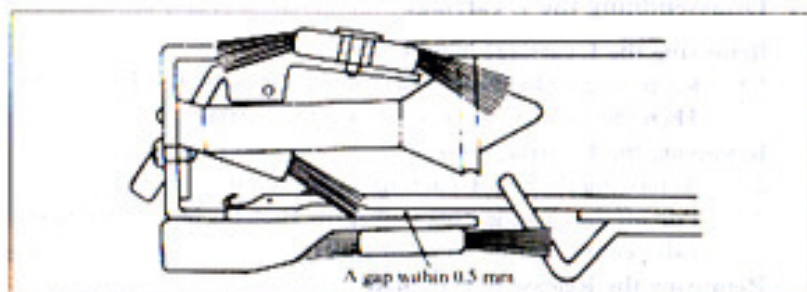
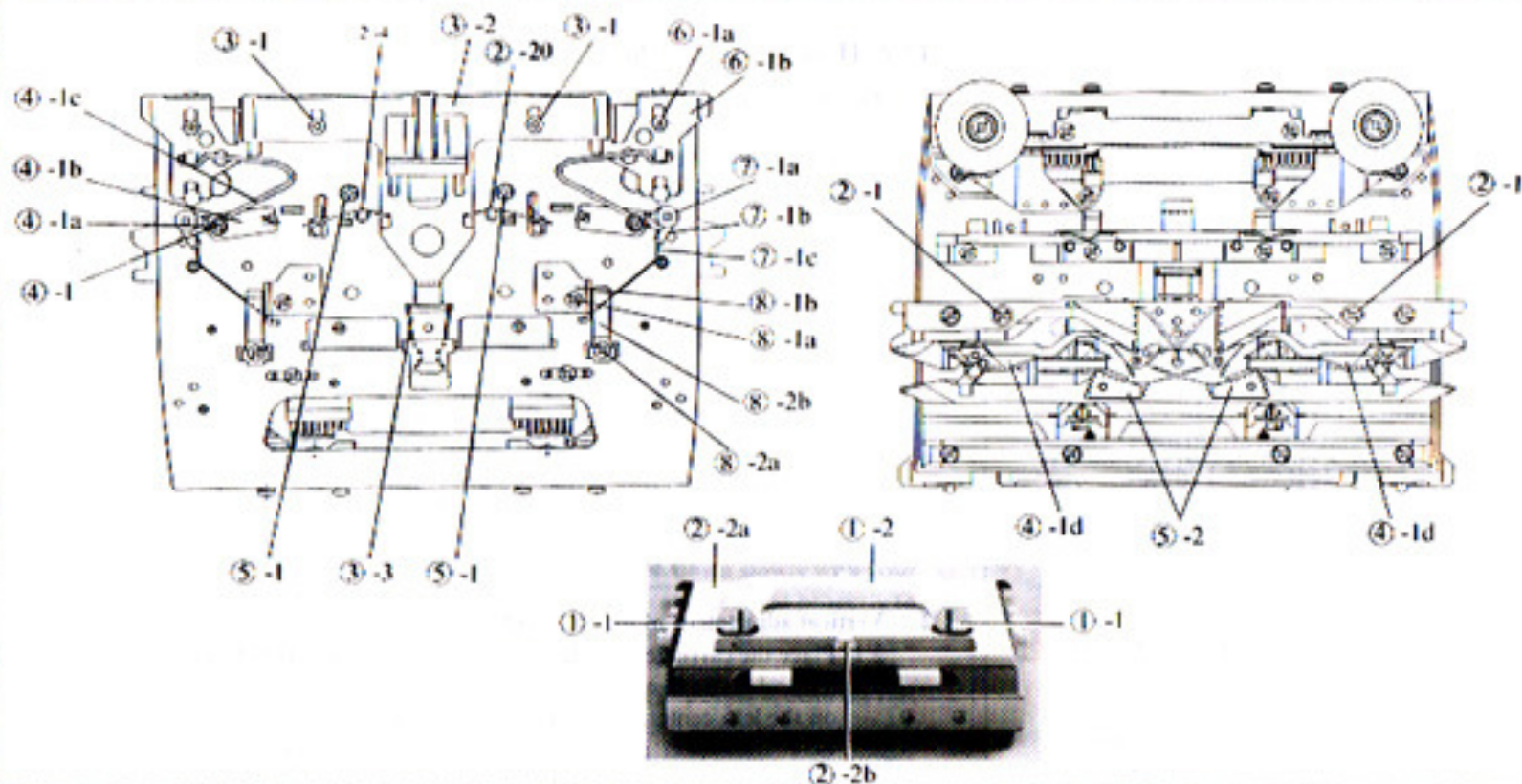

Figure 12-3

13. DISASSEMBLY, ASSEMBLY, AND ADJUSTMENT OF THE L CARRIAGE



Name of parts

- ①-1a Screw
- ①-1b L carriage handle
- ②-1 Screw 3.18 — 40 × 4
- ②-2a L carriage cover
- ②-2b Lace selecting knob
- ②-2c Valve cam C spring
- ③-1 Stud nut
- ③-2 Release button plate
- ③-3 Change lever spring
- ④-1 L separation cam plate screw
- ④-1a Washer 3.3
- ④-1b Separation cam plate
- ④-1c Connecting plate spring
- ④-1d Separation cam
- ⑤-1 + - Screw 3.18 × 12
- ⑤-2 End needle separation cam
- ⑥-1a Stud nut
- ⑥-1b Connecting plate
- ⑦-1a Lever shaft (Stud screw)
- ⑦-1b Valve cam C
- ⑦-1c Valve cam C spring
- ⑧-1a Screw 3.57 40 × 5
- ⑧-1b L handle setting base
- ⑧-2a Screw 3.57 40 × 4
- ⑧-2b L handle spring

13.1 Disassembling the L carriage

1. Removing the L carriage handle

- 1.1 Keep the handle down and remove the right and left screws. Then the handle can be taken off the carriage.

2. Removing the L carriage cover

- 2.1 Removing the two L carriage cover screw.
- 2.2 Pull off the carriage cover upward. Then the lace selecting knob and the valve cam C spring will come off.

3. Removing the Release button plate

- 3.1 Remove the right and left stud nuts for release button plate.
- 3.2 Lift the release button plate and pull it out toward you.
- 3.3 Remove the change lever spring.

4. Removing the separation cam

- 4.1 Remove the separation cam plate screws from the front of L carriage, and the connecting plate spring, the separation cam plate, screws, washer, and the separation cam will all come off.

- 4.2 Remove the right and left in the same manner.

5. Removing the end needle separation cam

- 5.1 Removing the end needle separation cam screws (+ - screw 3.18 × 12) the front side of the L carriage.
- 5.2 Remove the left and right end needle separation cams.

6. Removing the connecting plate

- 6.1 Remove the left and right stud nuts for connecting plate and detach the left and right connecting plates.

7. Removing valve cam C

- 7.1 Take off the lever shaft (stud screw) and remove the valve cam C and the valve cam C spring.

8. Removing the L handle setting base and the L handle spring

- 8.1 Remove the right and left L handle setting base screws and remove the L handle setting bases.
- 8.2 Remove the right and left handle spring screws and remove L handle springs.

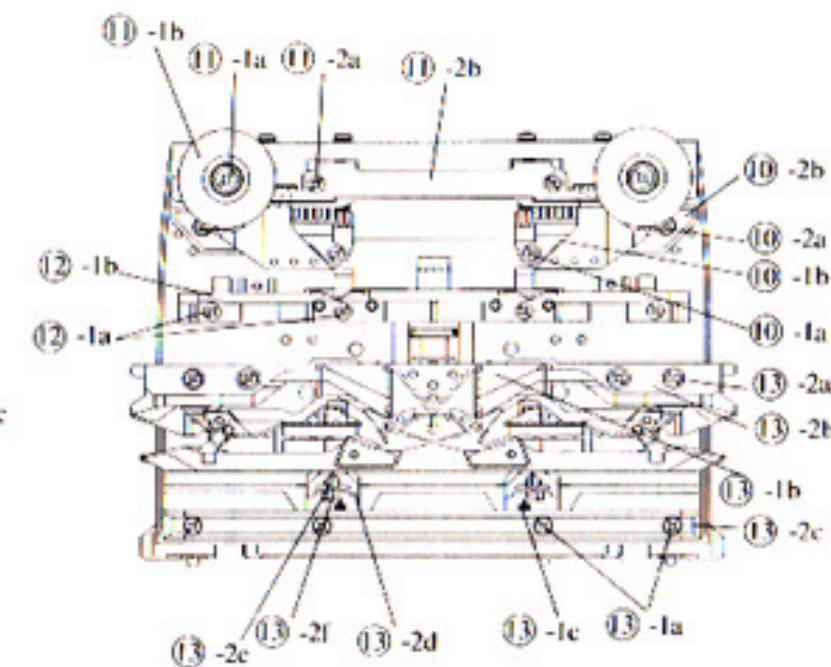
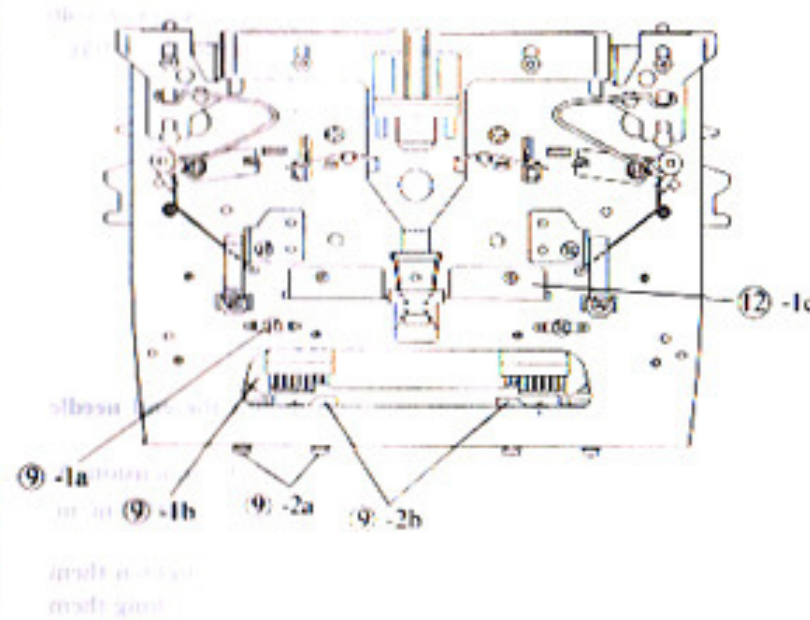

Name of parts	
9-1a	Screw 3.18 — 40 × 4
9-1b	Spring plate
9-2a	Screw 3.18 — 40 × 5
9-2b	Needle transfer plate
10-1a	Screw 3.18 — 40 × 5
10-1b	Yarn presser brush
10-2a	Flat screw
10-2b	Magnet
11-1a	Rubber wheel screw
11-1b	Rubber wheel
11-2a	Screw 3.18 — 40 × 4
11-2b	Cam plate
12-1a	Screw 3.18 — 40 × 8
12-1b	L front foot
12-1c	L front foot holder
13-1a	Screw 3.18 — 40 × 7
13-1b	Rear foot
13-1c	End needle selection spring
13-2a	Screw 3.18 — 40 × 8
13-2b	Main cam
13-2c	Lace selecting cam
13-2d	End needle selection cam
13-2e	End needle selection change cam
13-2f	End needle selection plate

- 9. Removing the spring plate and the needle transfer plate**
***Note:** Do not remove the spring plate and the needle transfer plate except replacing them.
- 9.1 Remove the spring plate screws and remove the left and right spring plates.
- 9.2 Remove the needle transfer plate screws and remove the left and right needle transfer plates.
- 10. Removing the yarn presser brush and magnet**
- 10.1 Remove the yarn presser brush screws from the rear of L carriage and remove the left and right yarn presser brushes.
- 10.2 Remove the magnet screws from the rear of the L carriage and remove the left and right magnets.
- 11. Removing the cam plate**
***Note:** Do not remove the cam plate except replacing it.

- 11.1 Remove the rubber wheel screws and remove the left and right rubber wheels (there is spring washer under the screws).
- 11.2 Remove the cam plate screws and remove the cam plate.
- 12. Removing the front foot**
- 12.1 Remove the four front foot screws from the rear of the L carriage and remove the L carriage front foot and the L front holder.
- 13. Removing the Main cam and rear foot**
***Note:** Do not remove the Main cam except replacing it.
- 13.1 Remove the four screws from the rear foot and remove the rear foot and the left and right end needle selection spring for L will come off.
- 13.2 Remove the two screws from the front two sides of main cam, with the reinforcing plate B and two valve cam B to the Main cam, remove the Main cam. At the same time, the lace selecting cam, the end needle selection cams, the end needle selection change cams, and the end needle selection plates will come off.

13.2 Assembling the L carriage

1. Mount the Main cam

- 1.1 Mount the end needle selection cam (right and left), the end needle selection change cam (right and left), the end needle selection plate (right and left) and the lace selection cam to the Main cam.
(Refer to Fig. 13-1).

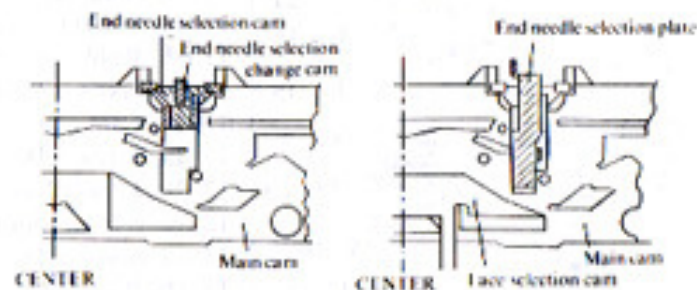

Fig. 13-1

- 1.2 Mount the Main cam to the L carriage plate, on which the above parts are mounted (refer to Fig. 13-2).
After that, tighten the Main cam lightly with two screws 3.18 — 40 × 8 (right and left), while pushing Main cam toward "arrow" direction (refer to Fig. 13-3).

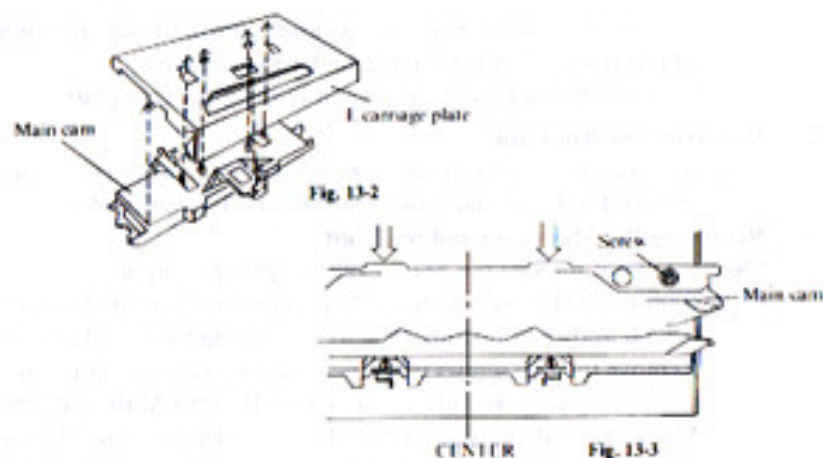

Fig. 13-2

Fig. 13-3

2. Mount the Rear foot

- 2.1 Mount the end needle selection cam springs (right and left).
(Refer to Fig. 13-4)
- 2.2 Mount the rear foot to the Main cam and tighten the four screws (3.18 — 40 × 7), while pushing it toward the "arrow" direction (Refer to Fig. 13-5).

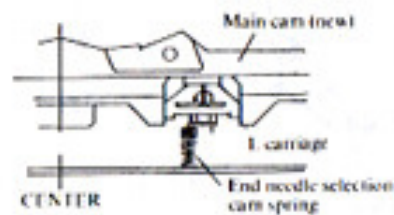

Fig. 13-4

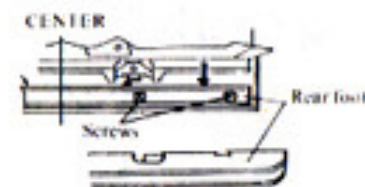
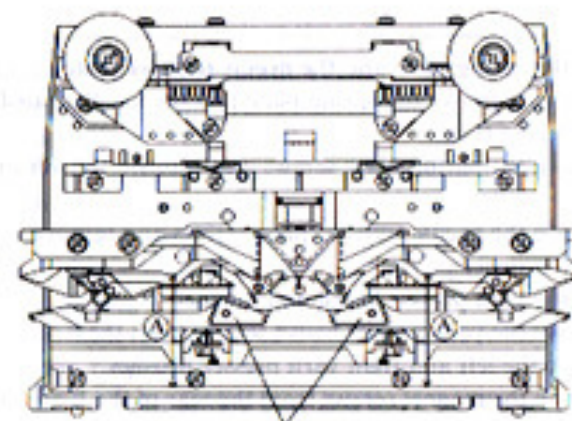

Fig. 13-5

3. Adjust the mounting dimension the Main cam and mount the end needle separation cam

- 3.1 After Mounted the Rear foot and the Main cam, adjust the dimension (A) in Fig. 13-6 (between Both inner faces of cam) within 45.2 m/±0.1 m/ m, and tighten the two screws of the Main cam.
- 3.2 Mount the end needle separation cam (right and left) and tighten them from front side with screws (3.18 × 12 with washer), while pushing them toward "arrow" direction (Refer to Fig. 13-6).



End needle separation cam
* Dimension (A) : 45.2±0.1 m/ m

Fig. 13-6

*** Other way to adjust the mounting dimension of the Main cam**

If you made the adjustment tool as shown in Fig. 13-7, you can adjust dimension (A) easily.

At first, place the adjustment tool between the Rear foot and the Main cam, then tighten the Main cam with two screws, while pushing it toward the "arrow" direction (Refer to Fig. 13-7).

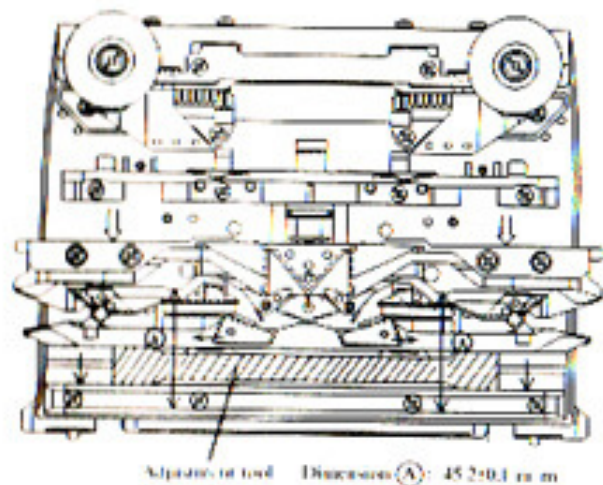
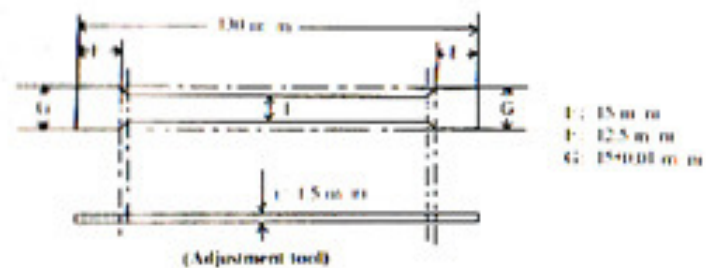
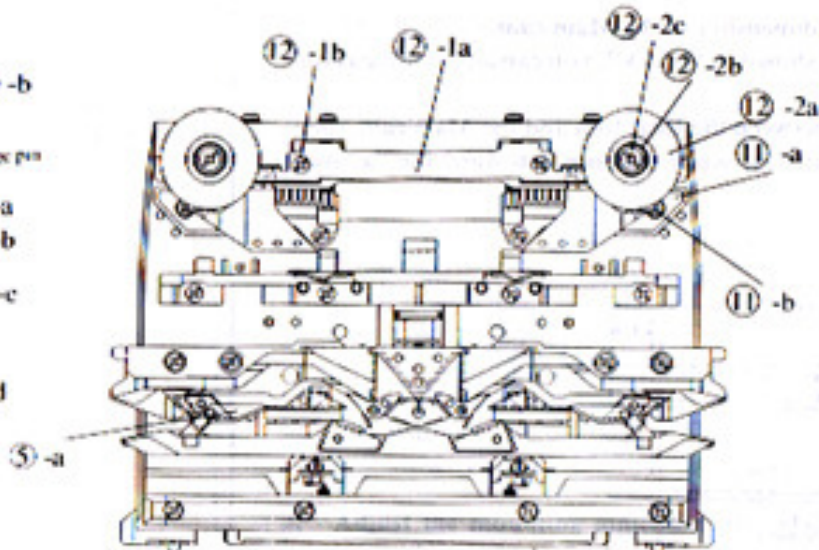
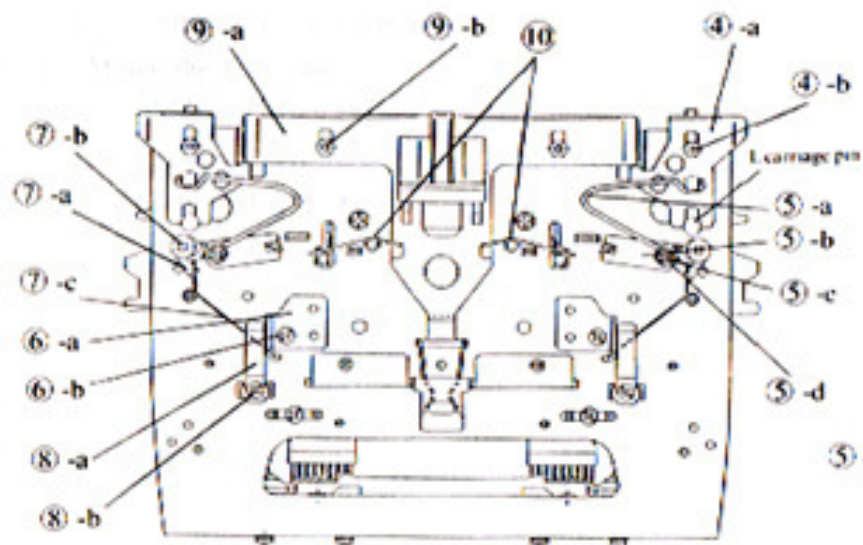

Fig. 13-7



Name of parts

- ④-a Connecting plate
- ④-b Stud nut
- ⑤-a Separation cam
- ⑤-b Separation cam plate
- ⑤-c Connecting plate spring
- ⑤-d Washer 3.3
- ⑤-e Screw 3.18 — 40 × 7
- ⑥-a L. handle setting base
- ⑥-b Screw 3.57 — 40 × 5
- ⑦-a Valve cam C
- ⑦-b Lever shaft (stud screw)
- ⑦-c Valve cam C spring
- ⑧-a L. handle spring
- ⑧-b Screw 3.57 — 40 × 4
- ⑨-a Release button plate
- ⑨-b Stud nut
- ⑩ Change lever spring
- ⑪-a Magnet
- ⑪-b Screw (flat head screw)
- ⑫-1a Cam plate
- ⑫-1b Screw 3.18 — 40 × 4
- ⑫-2a Rubber wheel
- ⑫-2b Spring washer
- ⑫-2c Stud screw

4. Mounting the Connecting plate

Push the right side connecting plate onto the L. carriage plate pin and tighten it with the stud nut.

* Mount both the right and left sides in the same manner.

5. Mounting the Separation cam

Mount the right side separation cam to the carriage plate from rear side of the carriage plate, and mount the separation cam plate, connecting plate spring and washer, then tighten them with screw (3.18 - 40 × 7).

After that, hook the connecting plate spring on the connecting plate.

* Mount both the right and left sides in the same manner.

6. Mounting the Handle setting base

Mount the right and left handle setting bases, respectively, with their screws (3.57 — 40 × 5).

7. Mounting the Valve cam C

Mount the valve cam C with the lever shaft (stud screw), and mount the valve cam C spring. The short stem of the valve cam C spring goes in the valve cam

C hole, and long side hooks onto the handle setting base.

* Mount both the right and left sides in the same manner.

8. Mounting the L. handle spring

Mount the L. handle spring left and right with screws (3.57 — 40 × 4).

9. Mounting the Release button plate

Mount the release button plate to carriage, and tighten it with stud nut at two points.

10. Mounting the Change lever spring

Mount the change lever spring onto carriage plate.

11. Mounting the Magnet

Mount the left and right parts of the magnet with screws (flat head screw).

12. Mounting the Rubber wheel and the cam plate

12.1 Push the cam plate lightly toward the front foot and tighten it with screws (3.18 — 40 × 4).

12.2 Mount the right and left parts of the rubber wheel and spring washer with screws (stud screws).

How to adjust

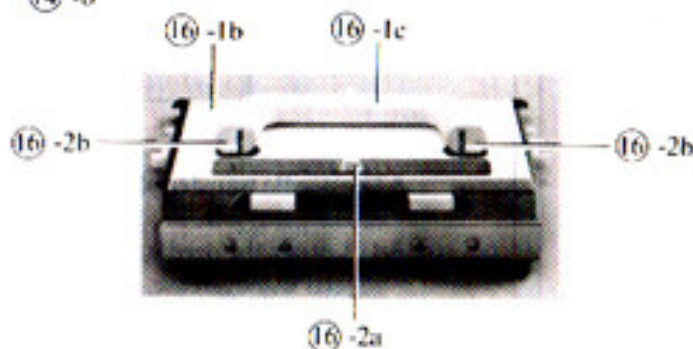
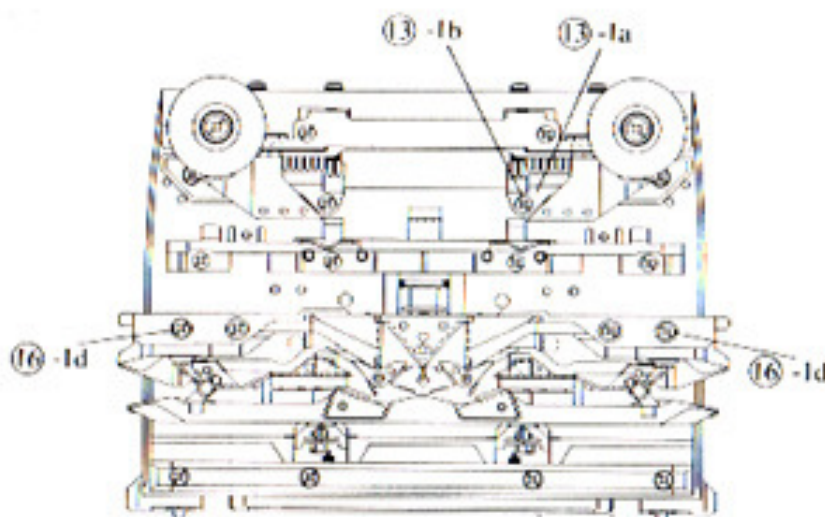
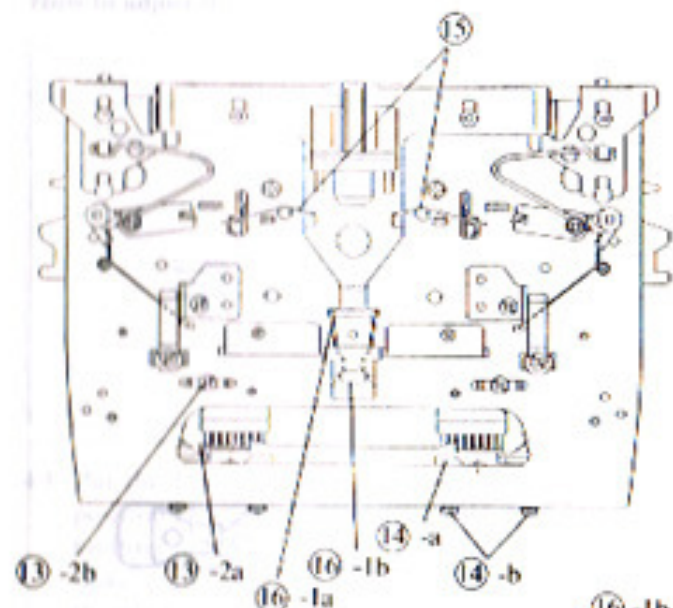

Name of parts

- 13-1a Yarn presser brush
- 13-1b Screw 3.18 — 40 × 4
- 13-2a Spring plate
- 13-2b 3.18 — 40 × 4
- 14-a Needle transfer plate
- 14-b Screw with washer
- 15 End needle selection change spring
- 16-1a Change lever spring
- 16-1b Lace selecting knob
- 16-1c L carriage cover
- 16-1d Screw 3.18 40 × 4
- 16-2a L carriage handle
- 16-2b Screw

13. Mounting the Yarn presser brush and the spring plate

- 13.1 Mount the yarn presser brush right and left screws (3.18 — 40 × 4).
- 13.2 After lightly tightening the screws on the spring plate right and left, and adjusting the horizontal position of them (refer to page 47), and tighten the screws.

14. Mounting the Needle transfer plate

Lightly tighten the screws (screw with washer) on the needle transfer plate, adjust the right and left sides (refer to page 47), and tighten them.

15. Mounting the End needle selection change spring

Place the right and left end needle selection change spring.

16. Mounting the L carriage cover and the L carriage handle

- 16.1 Place the change lever spring and the lace selecting knob and mount the L carriage cover, then tighten it with two screws (3.18 - 40 × 4).
- 16.2 Place the L carriage handle on the handle setting base and mount the handle screws.

13.3 How to Adjust the L Carriage

1. Adjusting the horizontal position of the spring plate

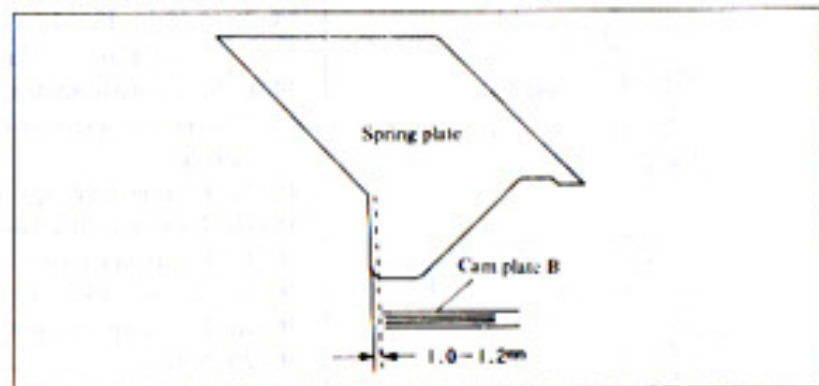

Figure 13-8

- 1.1 Remove the L carriage cover and loosen the left and right plate spring screws.
- 1.2 Secure the spring plate to a position within 1.0 - 1.2 mm from the face of cam plate B and tighten it with screws.

2. Adjusting the vertical position of the spring plate

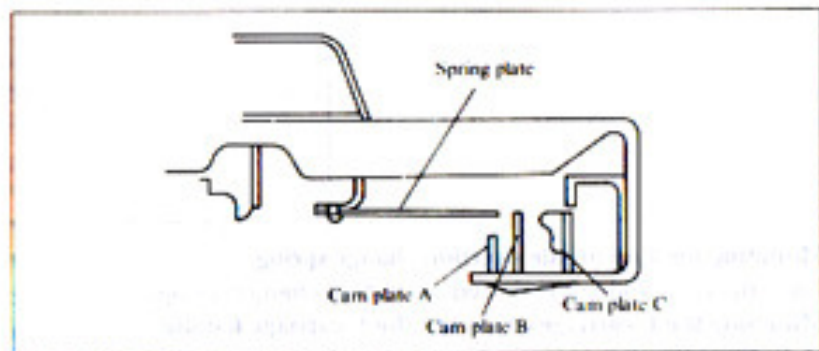

Figure 13-9

- 2.1 Prepare cam plate B by placing the tip of the spring plate at the same height as cam plate B.
- 2.2 Be sure not to bend any part of the spring when making the adjustment with pincers or pliers.

3. Adjusting the position of the needle transfer plate

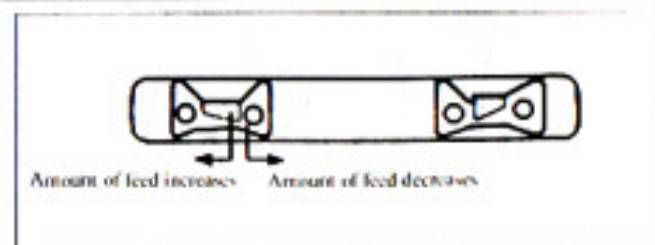
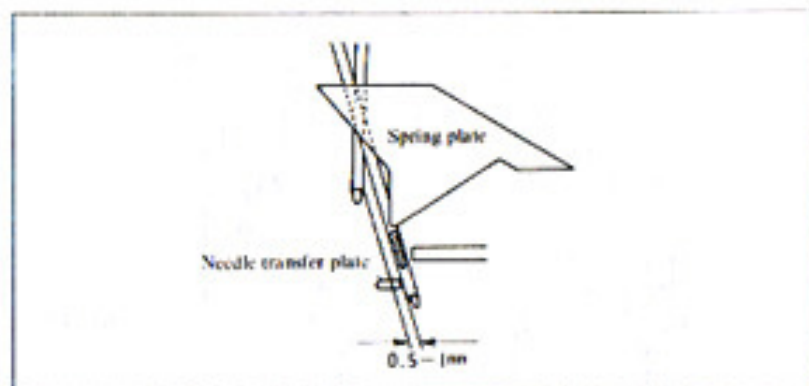

Figure 13-10

- * The needle transfer plate is secured by the needle transfer plate screws on the sinker plate side.
- 3.1 Loosen the needle transfer plate screws. When the tab is moved inward the feed will decrease, and when it is moved outward the feed will increase.
- 3.2 Adjust so that the gap between the two intersecting needles is 0.5 - 1.0 mm at the point at which they separate from the feed tab.

4. How to adjust the sinker plate bend

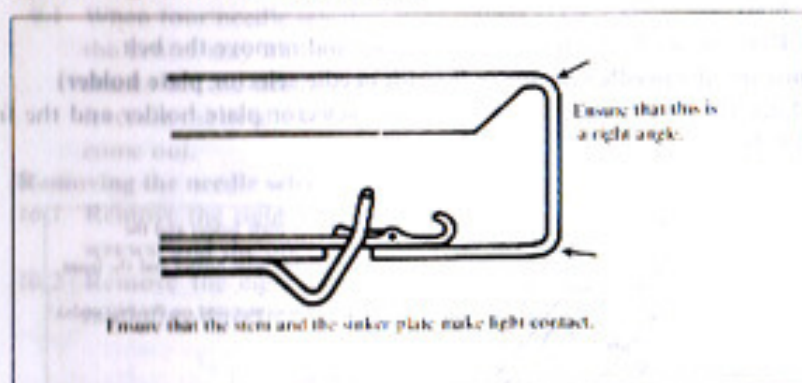

Figure 13-11

- 4.1 Put the L carriage over the needle bed, extend the knitting needles to position D, and check the gap between the L carriage sinker plate and the knitting needle stems. If the needles have been brought higher than the sinker plate, or if there is a gap, assume that the sinker plate is bent. Correct the bend in such a way that there is light contact made between the stems and the sinker plate.

14. DISASSEMBLY AND ASSEMBLY OF THE MAIN BODY

14.1 Disassembling the Main Body

1. Removing the panel

* Removal sequence: first, the pattern case whole unit is removed, and then the accessory box assembly.

1.1 Removing the pattern case whole unit

Remove the two screws, and then, while lifting the left side of the panel, slide it to the left and remove it from the right of the lower side plate, turning it over and then upside down toward the rear of the main body.

* There are six connectors joined to the main PC board on the rear of the pattern case whole unit which make it difficult to raise the operation panel. Be sure to exercise sufficient caution when raising the pattern case whole unit so as not to damage these connectors.

1.2 Disconnect the six connectors from the main PC board at the rear of the pattern case whole unit.

2. Removing the accessory box assembly

2.1 Remove the two screws (one of them is inside the accessory box), then, while raising the right side of the assembly, slide it toward the right and remove it from the left of the lower side plate.

3. Removing the left belt cover

3.1 Remove the two screws on the left side of the belt cover and remove the belt cover by bringing it toward you, turning it upside down.

4. Removing the main body

4.1 Remove the power PC board connectors.

4.2 Remove the two screws from the yarn tension stand.

4.3 Remove two screws each from both the left and right of the needle bed.

4.4 Remove one screw from both the left and right of the front needle bed.

4.5 Remove two main body screws each from both the left and right of the rear of the main body, and then remove the table clamp setting plate.

4.6 Raise the right side of the needle bed gently and slide it toward the right, removing it from the bottom of the case.

5. Removing the power PC board, the left position sensor PC board and the right position sensor PC board

5.1 Cut the binder from the yarn tension stand.

5.2 Take the screws from each of the PC boards and remove them.

6. Removing the cord cover

6.1 Remove the three screws from the cord cover and remove the cord cover.

7. Removing the belt

7.1 Loosen the pulley adjusting plate screws (Ref. No. C-60) on the pulley holder plate on the left side of the main body.

7.2 Turn the pulley to move the belt joint before you to the center of the main body.

7.3 Remove the belt screws from the hole and remove the belt.

8. Removing the needle selector unit (with needle selector plate holder)

<Check the distance between the needle selector plate holder and the front needle bed>

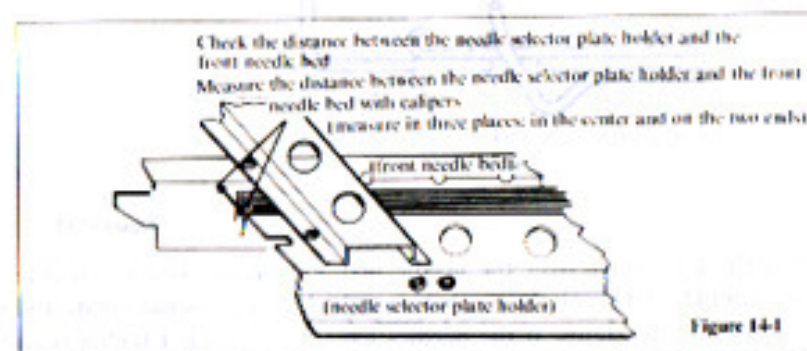

Take the measurements given the figure above and write them down, following the same measurements again during reassembly.

Note:

1. Do not remove the 10 screws on the needle selector holder or the 5 screws on the needle selector unit unless the needle selector unit is being disassembled.
2. When adjusting the mounting measurements of the gate peg, the stay need not be removed.
3. In the repair of the main body rotary cam lever and N.S.P. operation levers, the source of the problem may be discovered by removing the needle selector solenoid, the rotary cam lever holder, and the cam lever spring presser plate.
- 8.1 When the yarn tension support, lower holder plate, yarn tension stand and the 18 screws with washers on the two gate peg right and center stays are removed, the needle selector unit and needle selector plate holder will come off as a single assembled unit.

9. Removing the needle selector plate holder from the needle selector unit

9.1 When four needle selector plate holder screws are removed, two from the center stay and two from the right stay, the needle selector unit comes off the needle selector plate holder. The 16 NSP operation levers in the needle selector plate holder and the needle selector unit also come out.

10. Removing the needle selector plate holder

10.1 Remove the right lower holder plate, the two operation lever presser screws, and the operation lever presser.

10.2 Remove the right needle selector plate springs. (Make sure of the mounting direction and position of the springs before removing them.)

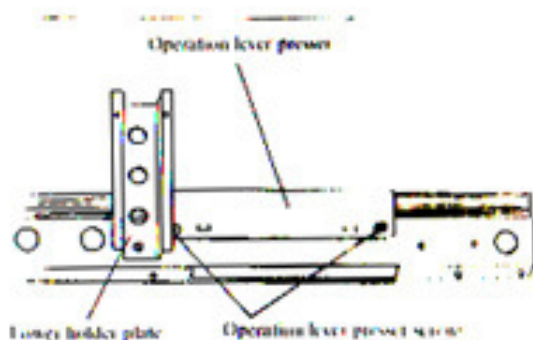

Figure 14-2

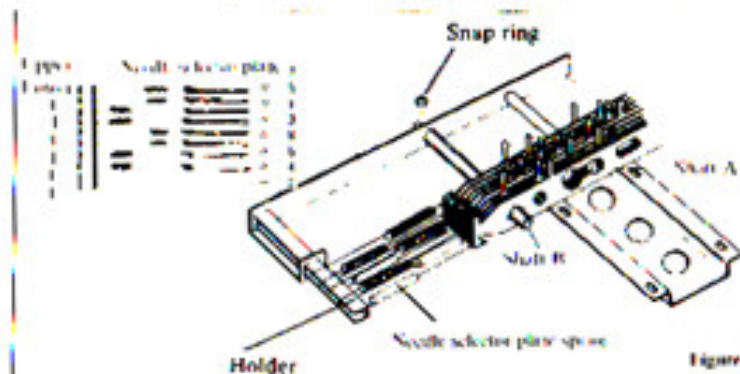

Figure 14-3

10.3 Remove the needle selector plate shaft B (angled) snap ring 2.5 from the rear side of the needle selector plate holder and pull the needle selector plate shaft out toward you.

10.4 Sliding each of the 8 needle selector plates toward the right, one by one, take them off the 6 grooves on shaft A.

11. Disassembly of the needle selector unit

11.1 Remove the screw from the encoder board holder plate and remove the encoder board holder plate.

11.2 Remove the 4 screws from the encoder PC board and remove the encoder PC board.

11.3 Take out the slit disc.

11.4 Removing the needle selection solenoid unit.

When the two screws on the right of the belt cover are removed, the needle selection solenoid unit will come off.



Figure 14-4

11.5 Removing the rotary encoder

(1) Remove the encoder board holder after removing the two screws and washers.

(2) Take the snap ring and washer from the rotary encoder shaft and remove the rotary encoder.

Note:

The washer on the rear of the rotary encoder has grease on it so be cautious that it is not lost when it comes off.

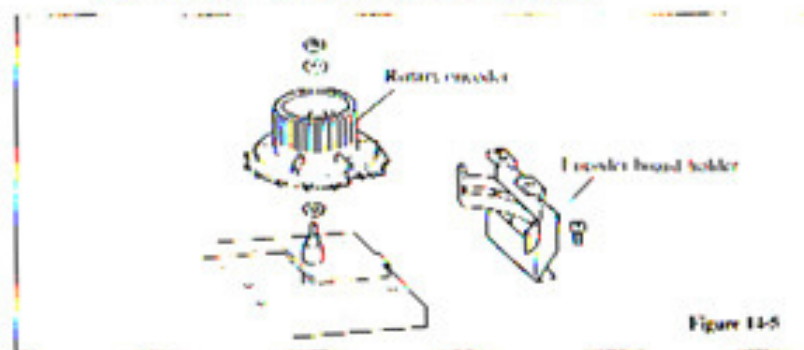
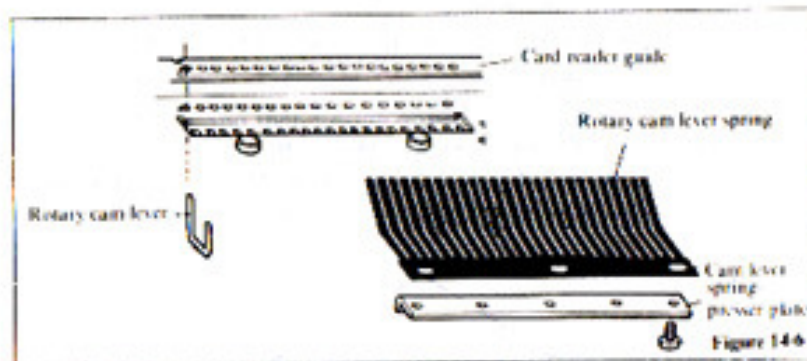

Figure 14-5

11.6 Removing the rotary cam lever

- (1) When the five cam lever spring presser plate screws are taken off, the cam lever spring presser plate and rotary cam lever spring come off and the 16 rotary cam lever may be taken out.



11.7 Removing the rotary cam

- (1) Take out the bevel gear spring pin and the slit disc spring pin.
- (2) Loosen the right and left rotary cam adjuster collar screws.
- (3) Take out the rotary cam holder (left) screws and then the rotary cam holder.
- (4) When the rotary cam is pulled toward the left and out of the rotary cam holder (right), the bevel gear and spacer will come out.

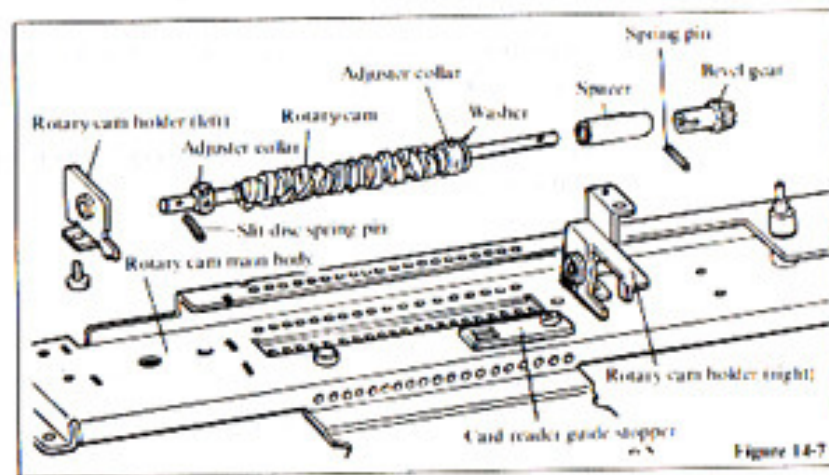

14.2 Assembling the Main Body

1. Mounting the needle selector unit

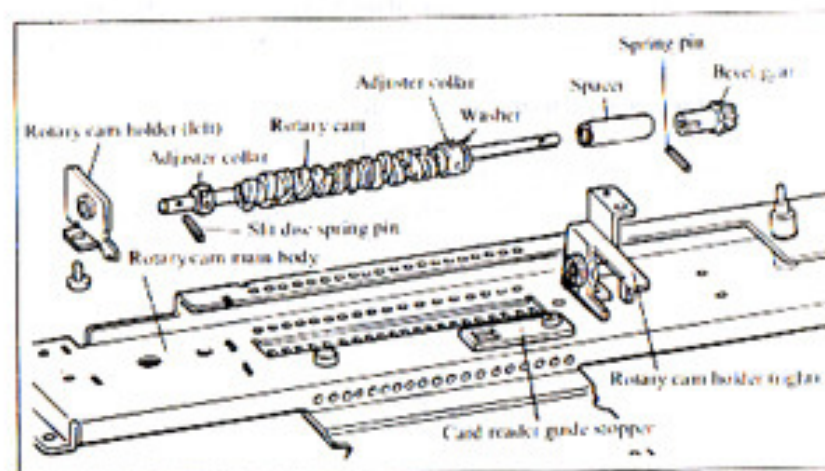

1.1 Mounting the rotary cam

- (1) Place the adjuster collars onto both ends of the rotary cam.
- (2) Place the washers onto the side of the rotary cam with the bevel gear spring pin hole, pass it over the rotary cam holder (right), place the spacer on, knock the bevel gear spring pin into its hole, and put the bevel gear on.

(3) Insert the rotary cam holder (left) onto the other side of the rotary cam and install it to the main body.

(4) Knock the slit disc spring pin into place.

Note:

Do not put the slit disc spring pin in so that it is even on both sides (the short side should be about 2 mm.)

(5) Lightly oil the resin part of the rotary cam, the metal part of the bearing of the rotary cam holder right and left, and the teeth of the bevel gear with a soap based grease (Epinoch #1).

1.2 Mounting the rotary cam lever

(1) Apply grease (Epinoch #1) to the card reader guide stopper hole on the rotary cam main body.

(2) Insert the long side of the rotary cam lever into the guide hole of the main body, and insert the short side into the guide hole on the rotary cam lever.



(3) Apply grease to parts which come in contact with the rotary cam lever and cam lever spring and install the cam lever spring and the cam lever spring pressure plate. Install the cam lever spring pressure plate such that the side with the bend is toward the rotary cam lever.

1.3 Mounting the rotary encoder

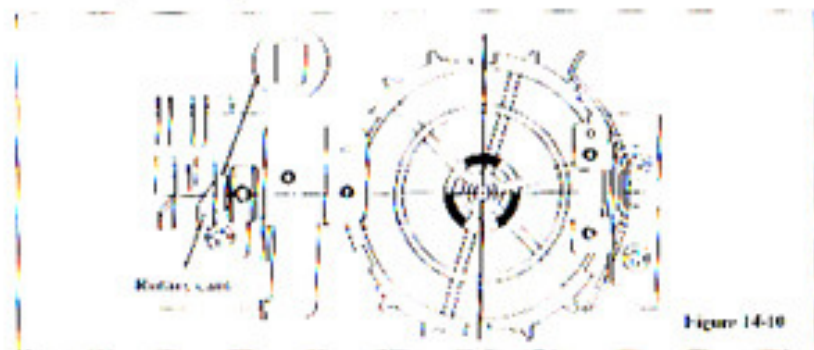

(1) Turn the rotary cam until the flat part of rotary cam's right end is straight down, as shown in the figure (14-10).

(2) Put the washer on the rotary encoder and place the rotary encoder such that its relationship to the rotary cam is as shown in Figure 14-10.

(3) Put the washer on and secure it with a snap ring.

(4) Mount the encoder board holder.

Note:

Apply grease (Epinoch #1) to the teeth of both the bevel gear and the rotary encoder.

1.4 Mounting the needle selector unit

(1) Place the needle selection solenoid armature on the tip of the rotary cam lever and install the right belt cover and the two installation screws.

2. Mounting the needle selector plate holder

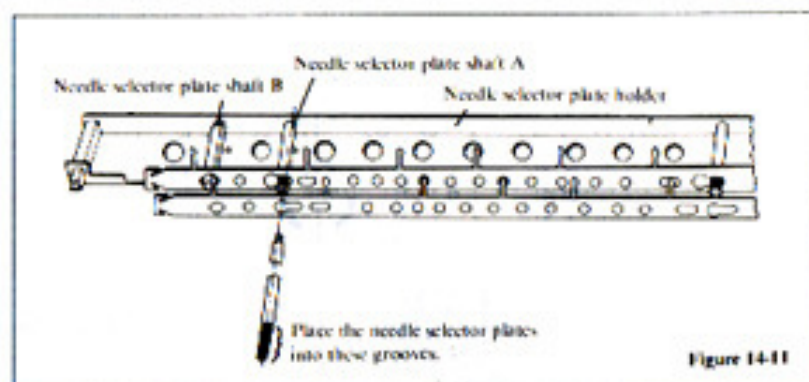

2.1 The needle selector plate holder should be mounted in the following sequence:

(1) Fit needle selector plate number 7 into the six grooves in needle selector plate shaft A of the needle selector plate holder, and, sliding it toward the left, push it in (refer to figures 9-24).

* The grooves in needle selector plate shaft A go, from the needle selector plate holder side, in the following sequence: 7, 5, 1, 3, 8, 6, 4, and 2. Exercise sufficient caution in this regard when pushing the needle selector plates into the needle selector plate holder.

* Also be cautious to ensure that the plates are not bent so far that they break when being inserted.

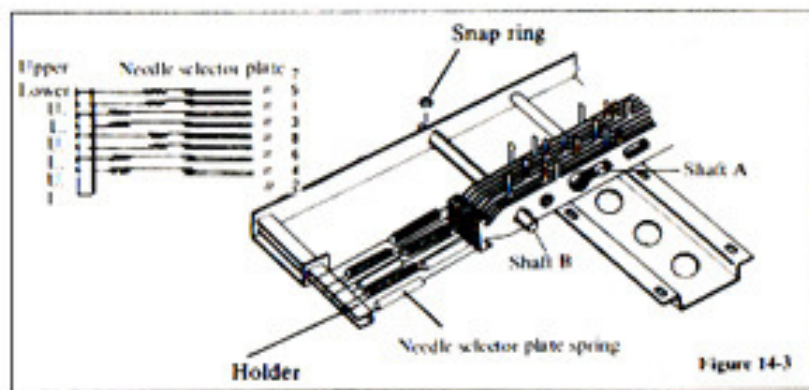

(2) Next hook the needle selector plate spring onto needle selector plate 7 and the needle selector plate holder spring hook.

* The needle selector plate spring should be hooked as follows: 5, 3, 6, and 2, from the needle selector plate holder side, should be hooked to the spring hook on the lower side of the needle selector plate. The remaining plates, 7, 1, 8, and 4 should be hooked on the spring hook on the upper side of the needle selector plate.

* The springs should be hooked alternately to the top and bottom of the plates.

(3) Next place needle selector plate 5 to the needle selector plate holder in the sequence given in 1) and 2) above. Similarly, place the remaining needle selector plates, 1, 3, 8, 6, 4, and 2 to the needle selector plate holder, in that sequence (refer to figure 9-25).

(4) After placing the needle selector plates, insert needle selector plate shaft B (angled) and secure it with a snap ring 2.5 (refer to figure 9-25).

3. Mounting the needle selector unit and the needle selector plate holder to the main body

3.1 Mount the needle selector plate holder and the needle selector unit to the center and right stays. The mounting holes in the center and right needle selector plate holder stays and in the needle selector unit are oblong horizontal holes, so use the center of the hole and tighten only lightly.

3.2 Put the 16 N.S.P. operation levers through the holes in the needle selector plate and into the left side of the rotary cam lever and mount the N.S.P. operation lever presser.

4. Mounting the needle selector unit and the needle selector plate holder to the main body

4.1 Place the needle selector plate shaft B of the needle selector plate holder into the angled hole in the main body.

4.2 Put one screw into each of the oblong, vertical holders in the main body for the installation of the center and right stays, tightening it only lightly.

4.3 Adjust the center of the rotary encoder so that it has the same relationship as in the above figure and tighten the center and right stays.

4.4 Install the yarn tension support, table clamp setting plate, and yarn take-up stand in such a way that the main body and the needle selector plate holder will be set in parallel with each other.

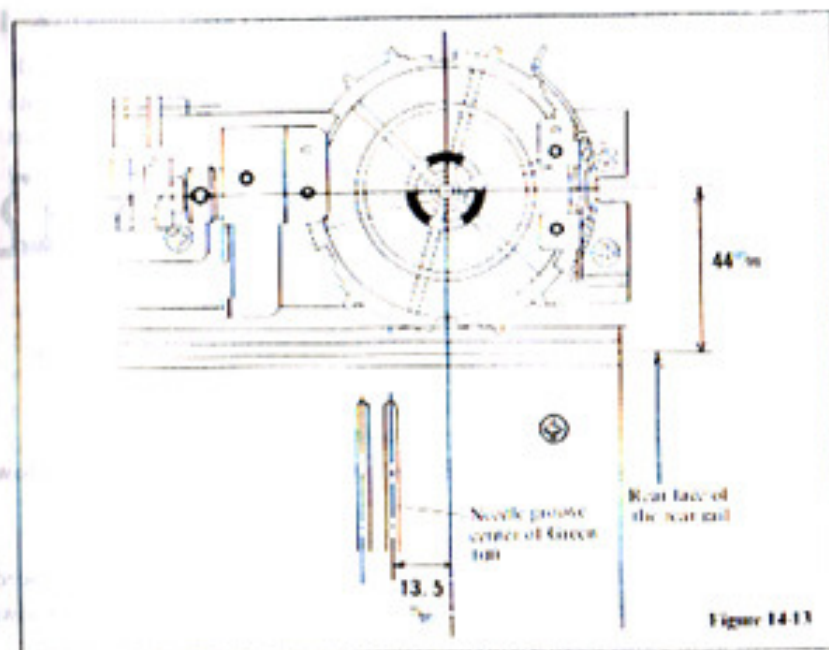

5. Mounting the belt

- 5.1 Take the belt connecting pin such that it is on the inside and place it on the belt cover (right) groove, fitting onto the rotary encoder as shown in the figure 14-14.
- 5.2 Turn the rotary encoder pulley by the rib and pull out the rear rail side. When turning the rotary encoder, be certain not to turn it by the comb.
- 5.3 On the left side, similarly, place the belt so that the long hole in it is matched to the notch in the pulley and pull out to the rear rail side.
- 5.4 Pull both ends of the belt together so that the connector pins link with the joint hole in the other.
- 5.5 Adjust the pulley adjusting plate. (Ref. No. C-60) With the pulley pushed toward the right, adjust it so that it can move 0.3 to 0.6 mm and tighten the screws.

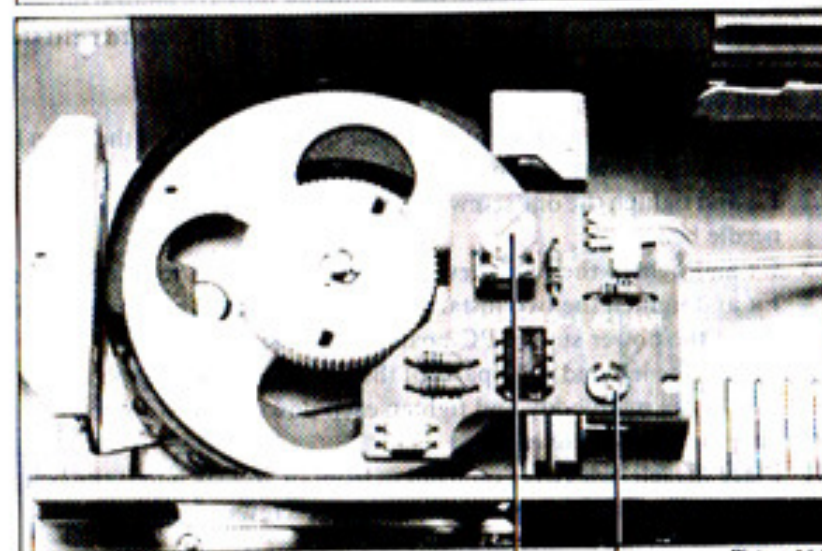
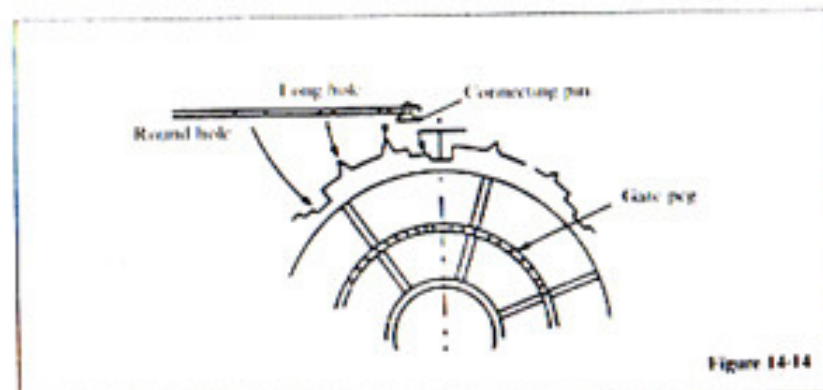

VR Left position sensor board

6. Mounting the encoder PC board

- 6.1 Fit the encoder PC board to the encoder board holder plate and tighten it up with the four screws.
- 6.2 Place the slit disc onto the rotary cam shaft (ensure that it is placed on so that the slit disc goes on properly).
- 6.3 Place the encoder board holder plate and secure it with one screw.
- 6.4 Place the board cord cover and secure it with three screws.

7. Mounting the power supply PC board, the left position sensor board and the right position sensor PC board.

- 7.1 Tighten each of the PC boards down with screws.
- 7.2 Gather the cords of the left position sensor PC board and the power supply PC board together in the hole under the yarn tension holder and secure them with a binder (the left position sensor PC board cord should pass under each of the stays).

8. The main body housing

- 8.1 Place the needle selector plate holder on the left side of the main body over the left lower side plate and put the main body under the case.
- 8.2 Fit and tighten the one screw on each the left and right front portions of needle bed.
- 8.3 Fit and tighten the two screws on each the left and right needle beds.
- 8.4 Fit and tighten the two installation screws on the yarn tension stand.
- 8.5 Insert the power supply PC board connectors.
- 8.6 Mount the left and right parts of the table clamp setting plate from the rear of the main body and tighten each down with two screws.

9. Mounting the left belt cover

- 9.1 Place the left belt cover on from in front of you such that the belt goes inside of it and tighten it down with two screws.

10. Mounting the accessory box assembly

- 10.1 Insert the left part of accessory box into the left lower side plate.
- 10.2 Tighten the two (one goes inside the accessory box) screws (the cord for the left position sensor PC board should pass through the rear of the case).

11. Mounting the pattern case whole unit

- 11.1 Insert each of the connectors to the main PC board, rear of the pattern case whole unit (in six places).
- 11.2 Insert the right part of pattern case whole unit into the lower side plate right.
- 11.3 Fit and tighten the two installation screws.

14.3 How to adjust the needle bed comb (Ref. No. B-2 In Parts catalogue)

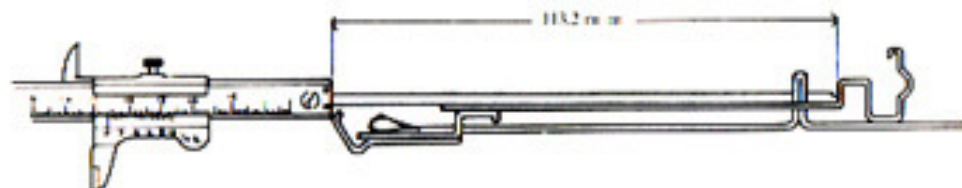

Figure 14-16

1. Take out the machine body from the lower case assembly (see p. 49).
2. Loosen 9 clamping screw for needle bed comb on stay right, center, and lower holder plate.
3. Loosen 12 clamping nuts on the back side of combs with a wrench.
4. Put out three needles each at both ends and in the central part of the needle bed and determine a position of combs so as to let needles come to midway between both combs. (Bilateral adjustment)
5. Set fitting measurement of combs at 113.2 mm at both ends and in the central part of the machine body and fasten with clamping nuts. (longitudinal adjustment)

* Note

In this case, keep it in mind that if such nuts are tightened too hard, screw will be twisted off.

Adjust measurement of fitting combs by use of a sliding calipers and fasten with clamping nuts (refer to Fig. 14-16).

15. ADJUSTMENT AND CHECK OF THE NEEDLE SELECTOR MECHANISM

15.1 Adjusting the Card Reader Guide Plate

- (1) Remove the pattern case whole unit and the remove the cord cover. The pattern case whole unit should be placed, with connectors still joined, to the rear of the main body.
- (2) Connect the power cord.
- (3) Turn the switch on and the MEMO key on.
- (4) Align all of the knitting needles to position A, set the K carriage change knob to KC(I) or KC(II). When the K carriage is operated, needle selector solenoids are all energized to be attracted.
- (5) Loosen the screws on the card reader guide stopper. Then, after sliding the card reader guide stopper over to the right, slide it very lightly back to the left, and tighten the screws such that the right window of the card reader guide plate lightly touches the contact.

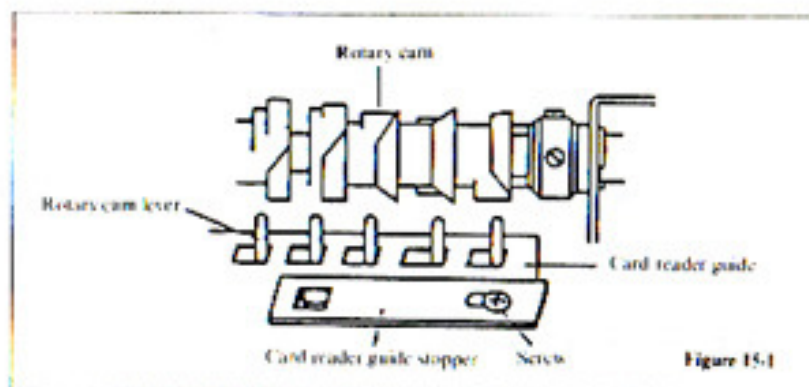

15.2 Adjusting the Rotary Cam Position

- (1) After the completion of the card reader guide plate adjustment, loosen the four stop screws on the rotary cam adjuster collar and the rotary cam presser collar.
- (2) With a feeler gauge make a 0.2 - 0.6 mm (TYP 0.3 mm) gap between the rotary cam and the rotary cam adjuster collar. Then, holding the rotary cam to the right with a flat head screw driver, tighten the screw (if no feeler gauge is available, approximate the distance visually).

- (3) Make a 0.2 mm gap between the rotary cam presser collar and the left rotary cam holder and tighten the screws. Tighten the four screws each twice to make sure that they are tight.
- (4) Place all the knitting needles at position B.
- (5) Turn the power switch off, turn the K carriage change knob to <KC(II)> and check all needles are selected to position D when the carriage is moved slowly and when it is moved quickly.

* The movement of the K carriage is unusually sluggish when there is no gap in the rotary cam pressure collar or when the gap in the rotary cam adjuster collar is too great.

* When there are needles which do not come out to position D, make the gap in the rotary cam adjuster collar greater.

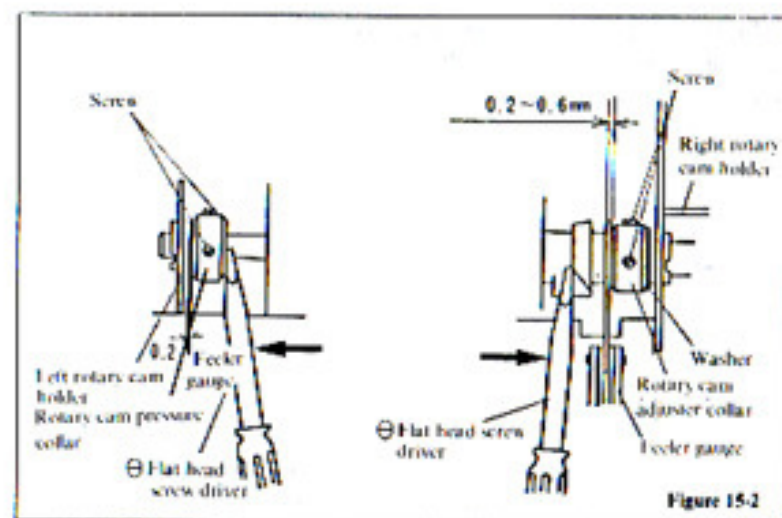

15.3 Checking the Needle Selector Mechanism

1. The objectives of check sequence 1

First of all, in order to determine whether the cause of the error in needle selection is in the needle selection mechanism (the mechanical portion), or in the electronic portion, move the carriage with the power turned off.

When the power is turned off, the solenoids are also all off, all of the rotary cam levers are on the rotary cams, and the knitting needles should all be selected to position D. The reason for turning the change knob to the KC(H) position at this time is that, as the K carriage separation cam is separated from the needle selection cam, because precision is required of the needle selector plate as it grasps and releases the knitting needles, it is especially easy for errors in needle selection to occur when operating at low speed.

With this test, the carriage needle selection mechanism, the rubbing surfaces of the needle selection solenoid armature, the rotary cam, the rotary cam levers, the N.S.P. operation levers, and the needle selector plate may be checked.

2. When the test determines that not all of the needles come out to position D, but that some remain in position B.

(1) When there is no regularity (e.g., 8 pitches, 16 pitches, etc.) in the needles remaining in position B

- The knitting needles are bent.
- The belt has not been properly mounted to the rotary encoder.
- The rotary cam has not been properly mounted to the rotary encoder.
- The card reader guide plate or the rotary cam position are out of adjustment.

(2) When the needles remaining the position B show regularity (8 pitches or $8 \times n$ pitches)

- The needle selector plate is not moving because the rotary cam levers and N.S.P. operation levers have not been mounted properly.
- The rotary cam lever is getting caught on the card reader guide and, slipping, do not move. *Apply grease.
- The needle selector solenoid armature and the solenoid yoke are getting caught, and, slipping, do not move.

- The armature spring of the needle selector solenoid is bent or has come loose.

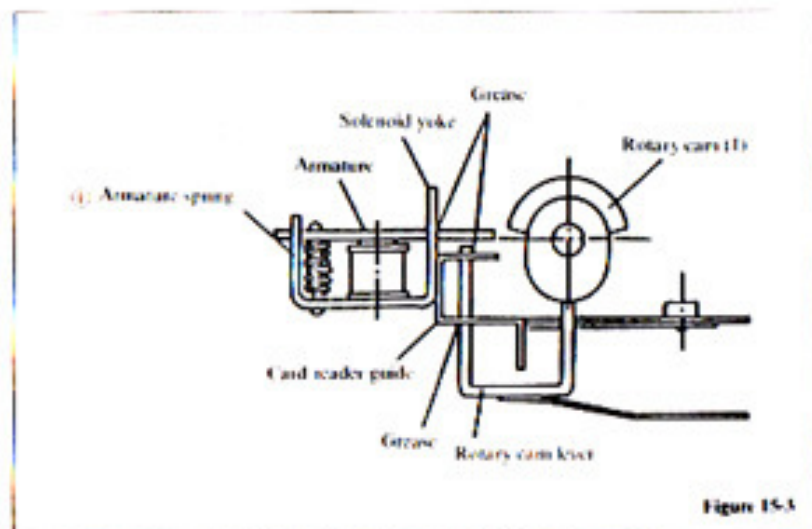

- The N.S.P. operation lever stay is interfering with needle selector plate number 2.
- The needle selector plate springs are loose or are interfering with one another.

3. When carriage operation is much heavy

- The carriage will not move
The carriage will not move when the rotary cam lever has come loose from the face of the rotary cam. When too much pressure is applied to the rotary cam lever, it will bend. After checking to ensure that the rotary cam lever has not become bent, adjust the positions of the card reader guide plate and the rotary cam.
- Carriage operation is not smooth
The rotary cam presser collar is making contact with the metal portion of the left rotary cam holder bearing. The gap between the rotary cam and the rotary cam adjuster collar is too wide.

*KG-88II/89II/93

1. KG-88II/89II/93 product characteristics and points different from KG-88/89

- 1) The same basic functions are shared between KG-88II and KG-88 and between KG-89II and KG-89. However, the following functions in items 2) and 3) are added to KG-88II and 89II.
- 2) The 'c' wrap method (cast-on) is possible.
- 3) The carriage stops automatically when tangled yarn passes through the yarn tension unit.
- 4) KG-93 has been developed for KH-940/930 and shares the above functions with KG-88II and 89II.

2. Product specifications

- 1) The basic color of the cover upper and lower assemblies has been changed from pearl white to white.
- 2) G carriage and knitting machine combinations

KG \ KH	860	881	890 891	892 893	910M	930 940	836
88II	Yes	Yes	No	No	*Yes	No	Yes
89II	No	No	Yes	Yes	No	No	No
93	No	No	No	No	No	Yes	No

Note

1. All of KG can not be used with KH models older than KH-860.
2. *: Additional parts (487341001) are required.
3. Parts for No. 487341001 include Row counter triper B (412417001), Knit-leader triper B (412416001) and Magnet holder assembly (412785001).

3. Differences between KG-88II/89II/93 and KG-88/89 in the disassembly and mounting of G carriage

- 1) In KG-88II 89II 93, the change lever for casting-on is mounted to the G carriage upper plate with the lever spring and the snap ring 4.

* In the event that the G carriage upper plate is removed, mount it again in the following manner.

Place the holes of the G carriage upper plate to the respective pins on the carriage plate. At the same time, mount the change lever for casting-on in such a way that it will be engaged with the G carriage feeding lever at the right side.



2) Selector knob

The mounting position of the selector knob is the same as that of KG-88/89. Put the turn knob to the automatic stop (←→) position of the G carriage upper plate, and place the knob on the plate. Also, put the selector knob to the 'c' wrap method and casting-off position, and place it onto the plate.



(Selector Knob)

4. Differences between KG-88II/89II/93 and KG-88/89 in the sensor

The detecting lever and its spring are added to KG-88II/89II/93.

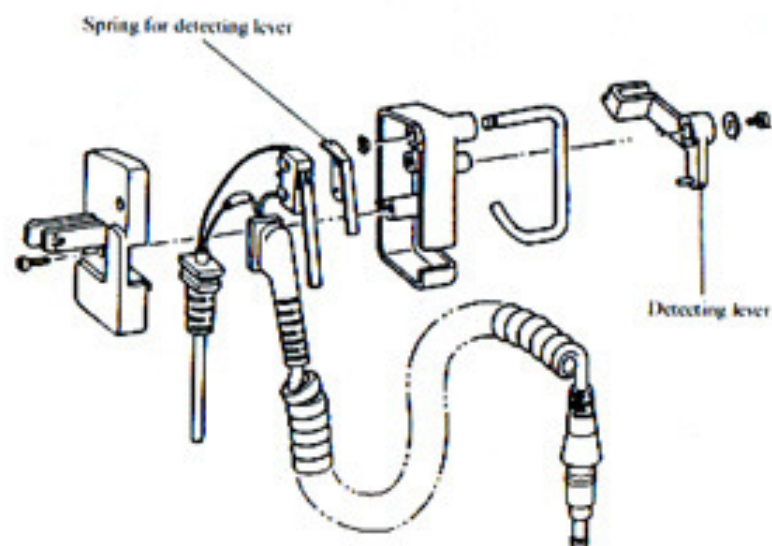

5. Troubleshooting

- 1) 'E' wrapping cannot be done.
cause The latch stopper brush is damaged.
remedy Replace the latch stopper brush.
- 2) Yarn feed is abnormal during 'e' wrapping.
cause The change lever spring for casting-on is weak.
remedy Replace the change lever spring for casting-on.
- 3) After 'e' wrapping, stitches in the next row are dropped.
*Refer to KG-88II/89II/93 operation manual and reset the cast-on comb.