

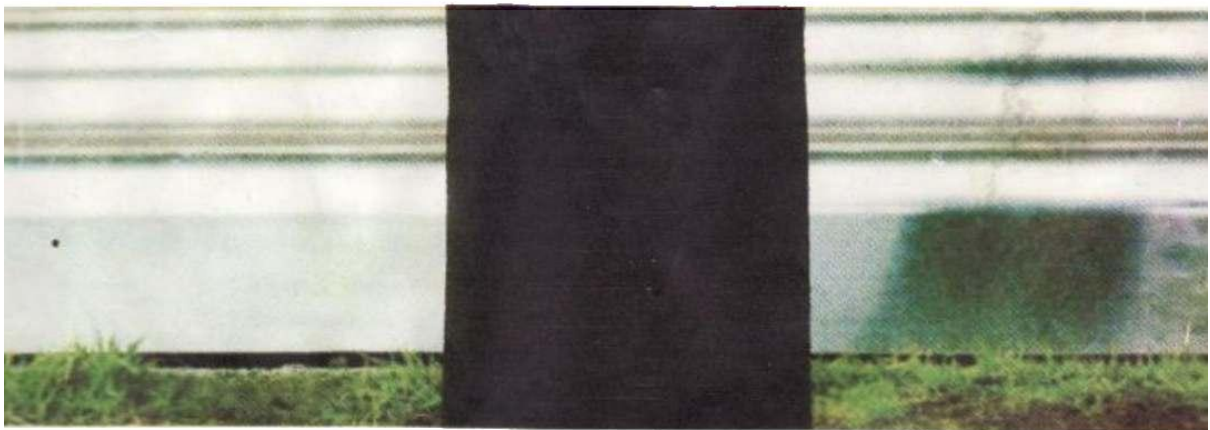

INSTRUCTION BOOK



MEMO-MATIC* KNITTING MACHINE BY **SINGER**

MODEL KE-2400

TABLE OF CONTENTS

NAME OF PARTS	1
ACCESSORIES	2
SETTING UP THE MACHINE.....	3
BEFORE KNITTING	6
1. Row counter	6
2. Row counter lever	6
3. Position of knitting needles.....	6
4. Stitch tension knob	6
5. Operation dials	7
6. Returning levers	7
7. Needle selection lever	8
8. Card feed dial	8
9. Pattern switch	8
10. Card feed switch	8
11. Accessories tray	8
12. Needle selection indicator window	8
HOW TO KNIT PLAIN KNITTING	9
1. Preperation of knitting	9
2. Casting on	10
3. Waste knitting	12
HOW TO KNIT PATTERN	13
1. Memory card	13
2. Relation between memory card and needle	13
3. How to set memory card	13
4. Preperation for pattern knitting	14
5. Pattern knitting	15
* Tow color pattern	15
* Slip stitch pattern	16
* Colored slip Stitch pattern	16
* Tuck pattern	17
* Color tuck pattern	17
* Weaving pattern	17
* Lace pattern	18
INCREASING AND DECREASING NUMBER OF STITCHES.....	20
1. Increasing one stitch	20
2. Decreasing one stitch	20
3. Increasing more than two stitches	21
4. Decreasing more than two stitches.....	21

VITAL POINTS TO REMEMBER IN KNITTING	22
1. Horizontal shaping	22
1) Shaped hem	22
2) Horizontal shaping for a bust dart	22
3) Shaping required at one side edge of work only	23
4) Horizontal shaping of lace knitting	23
2. Rib knitting	24
3. Garter stitch knitting	25
4. Cable or rope knitting	25
5. Cord or tube knitting	26
6. Casting off shoulders together	26
7. Grafting plain knitting	27
WHAT TO DO IN CASE OF DIFFICULTIES	28
1. Carriage jams halfway across row	28
1) Plain knitting	28
2) Pattern knitting	28
2. Correcting a mistake	29
1) Plain knitting	29
2) Pattern knitting	29
3. How to unravel a row of stitches	29
4. When a stitch slips down one row	30
5. When a stitch slips down a number of rows	30
6. When knitting needles are damaged	31
HOW TO USE CREATIVE PUNCH CARD	32
1. For the use when making patterns included in "Pattern Book 24 Vol. 1"	32
2. For the use when making your own pattern	32
CARE AND MAINTENANCE OF THE MACHINE	33
HOW TO STOW THE MACHINE AWAY	33
BASIC PATTERNS (42 different patterns)	35
CHART OF APPLICABLE PATTERN	42

NAME OF PARTS

Case Cover

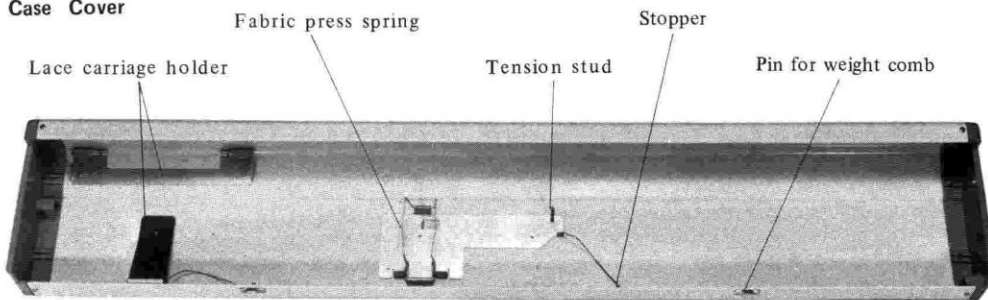

Machine body

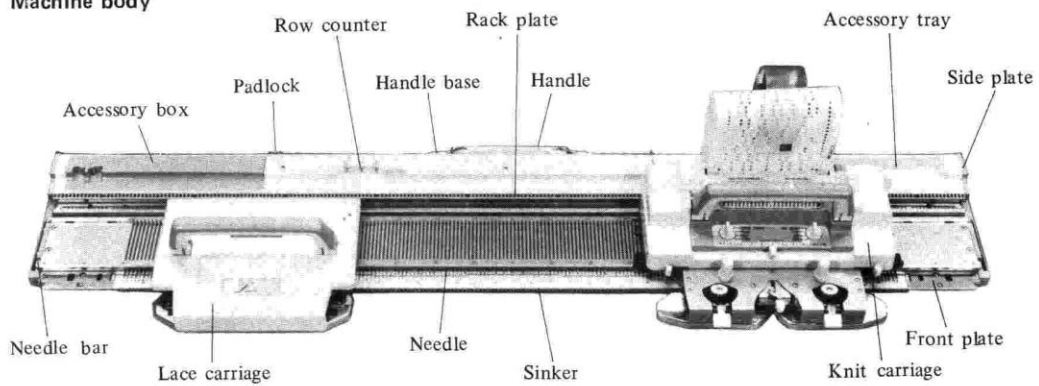

Knit carriage

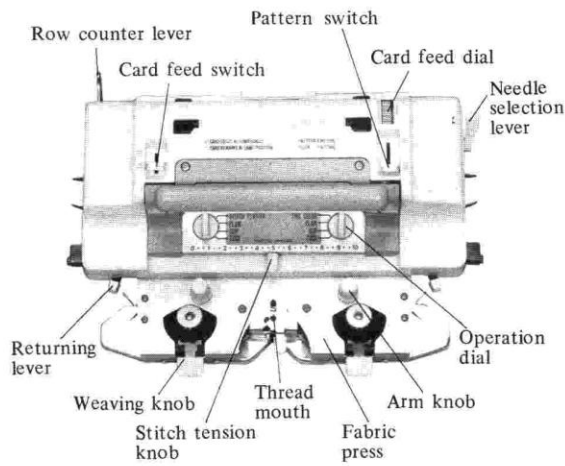

Lace carriage

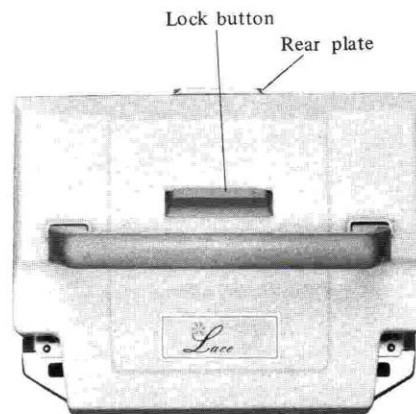

Needle

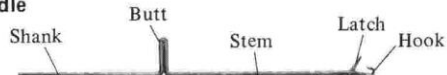

ACCESSORIES

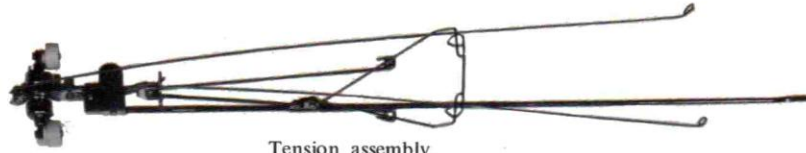

Tension assembly



Weight comb

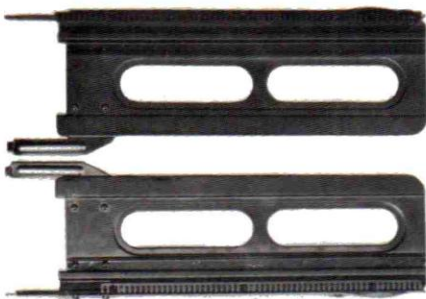

Extension rail

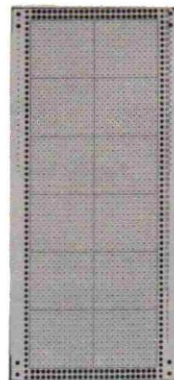

Creative punch card

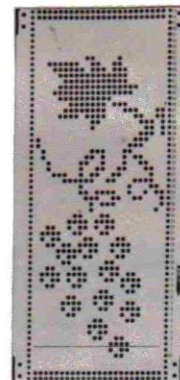

Memory card



Creative punch



Weights (Small)



Hand brush

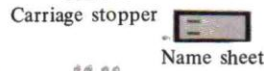

Carriage stopper



Removable cord

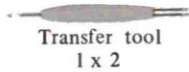

Transfer tool
1 x 2



Weights (C)

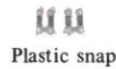

Plastic snap



Name sheet

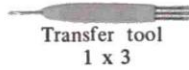

Transfer tool
1 x 3

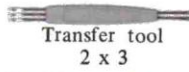

Transfer tool
2 x 3

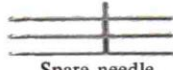

Spare needle



Oil

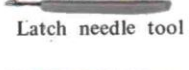

Latch needle tool

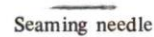

Seaming needle

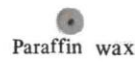

Paraffin wax



Card support



Crochet hook



Hook (B)



Carriage clamp

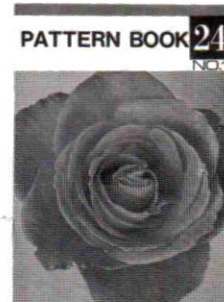

Pattern Book 24



Needle pusher
(1 x 3, Flat)



Needle pusher
(1x1, 2x1)

SETTING UP THE MACHINE

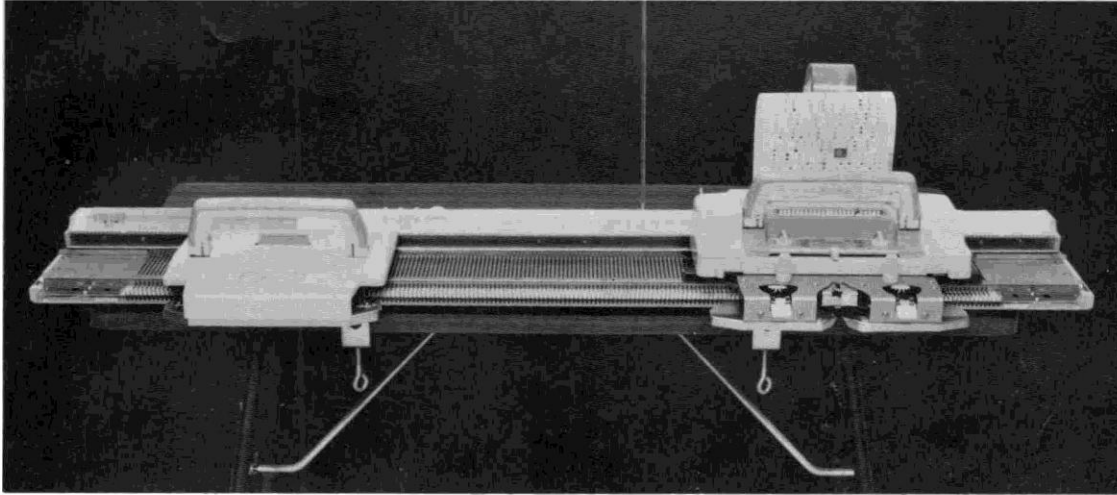

1. Pull out left and right clamps.

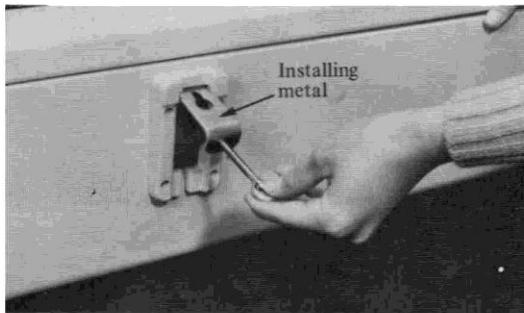

2. Place the knitting machine on the table with the handle on the far side and fix the machine on the table by tightening the clamps.

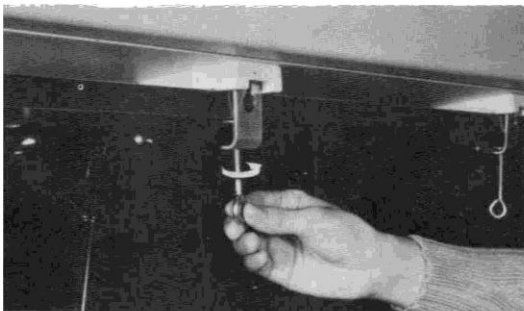

3. Remove left and right padlocks.

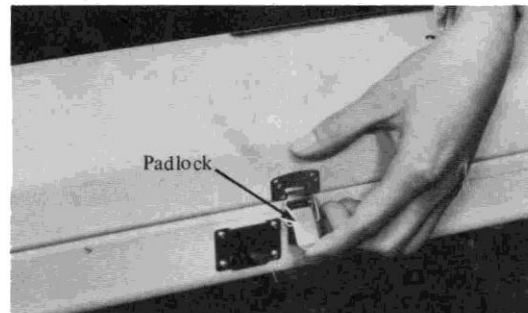

4. Lift up the case cover a little and pull it off.

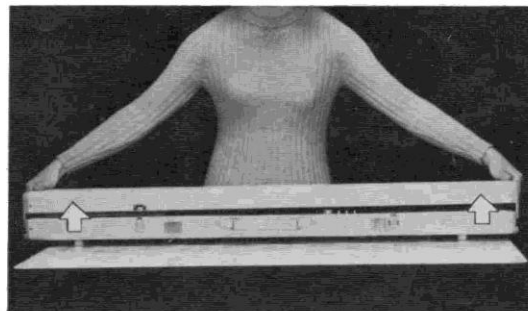

5. Raise the handle until it clicks into place.

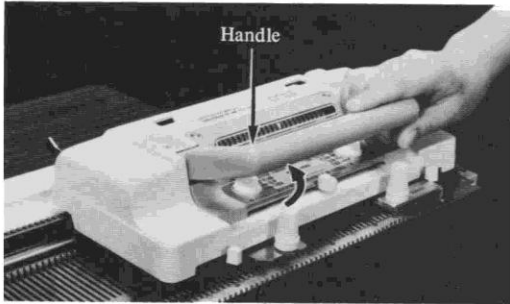

8. Remove the fabric press from the case cover.

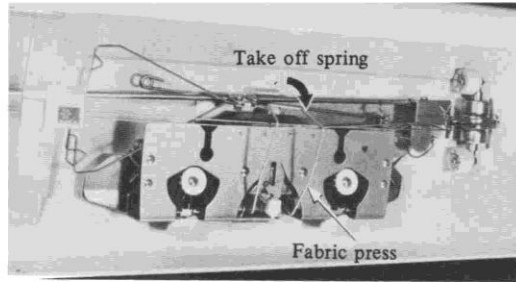

6. To lower the handle press the lock knob on the left side of handle, and push handle towards you.

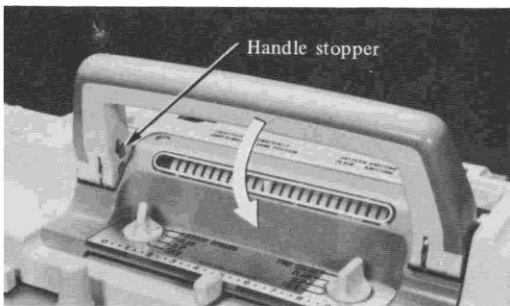

9. Loosen the other arm knob, insert the fabric press firmly and tighten both knobs.

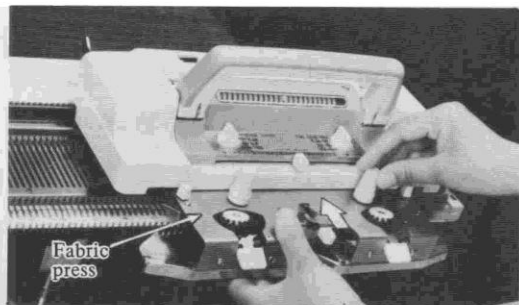

7. Loosen the arm knob and remove the carriage clamp.

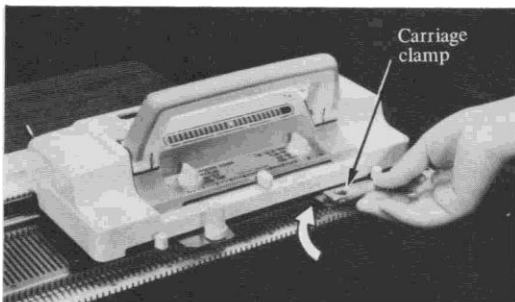

10. Remove lace carriage from the case cover by pushing the button in the direction of the arrow.

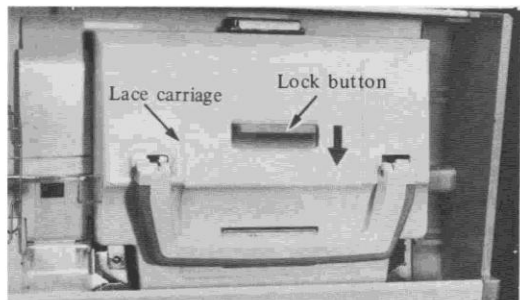

11. Remove the tension assembly from the case cover.

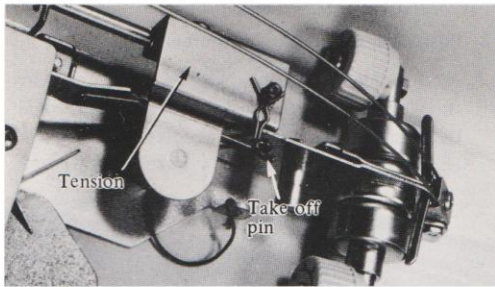

12. Pull out the tension spring from yarn guide A and lift it up turning fully. At the same time, open yarn guide A.

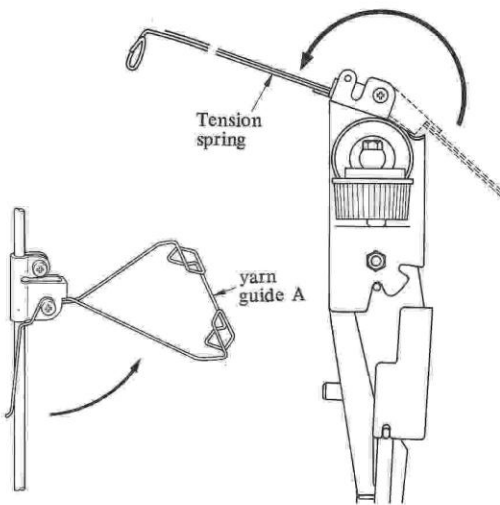

13. Set up the tension assembly as follows:
 A) Lift the tension assembly a little and take the pin off the groove.
 B) Turn and raise up the tension assembly as it is.

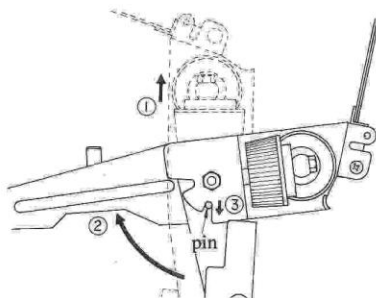

14. Insert the tension bar into the handle base.

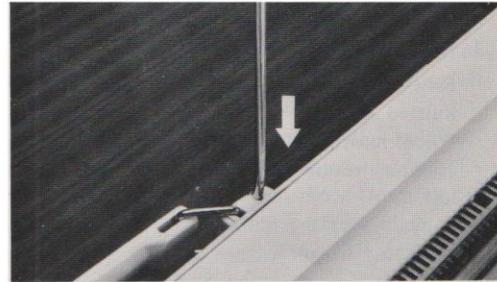

15. Insert the carriage stoppers into right and left side plates. When using the extension rails, carriage stoppers are not required.

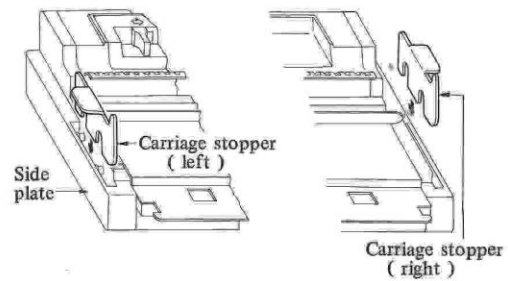

BEFORE KNITTING

1. Row counter

Row counter shows the number of rows knitted.

When returning to 000 or resetting the row counter, rotate the knobs either to right or left.

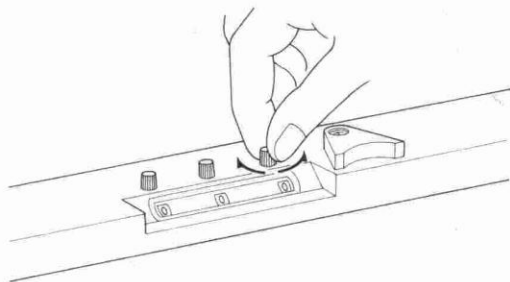

2. Row counter lever

- 1) Pull out the row counter lever pressing it down a little.



- 2) Move the carriage to left and right gently and check that the row counter lever connects with the driving plate.



3. Positions of knitting needles.

- A: Needles at rest. (Non-working position).
- B: Working position (for stocking stitch).
- D: Position of selected needles.
- F: Holding position.

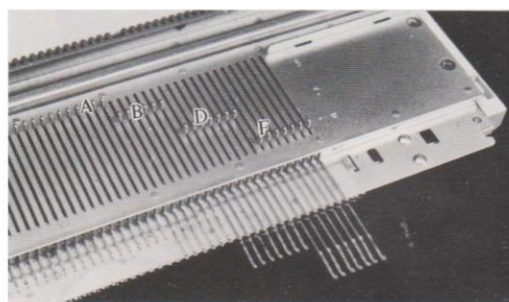

4. Stitch tension knob

- 1) The stitch tension (or gauge) is adjusted according to the thickness of the knitting yarn and the stitch size required. The higher numbers make a larger stitch size (looser fabric), and the lower numbers make a smaller stitch size (tighter fabric).

Note: The left-hand operation dial must be set to "STITCH TENSION" position when moving the tension knob.

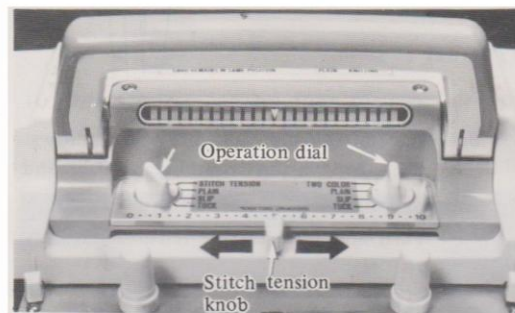

- 2) There are 2 graduations between each tension number, these are referred to as degrees. Tension numbers suggested in pattern instructions are written thus: T8, T8.1 (1 degree looser), T7.2 (1 degree tighter than T8).

Type of yarn	Stitches per 10 cms (4") in plain knitting	Suitable tension numbers
Very fine	45 - 37	0 - 3
Fine	39 - 32	3 - 6
Medium	34 - 28	5 - 8
Thick (D.K. or Sport Yarn) using every needle	31 - 27	8 - 10
Thick (D.K. or Sport Yarn) using alternate needle *	27 - 21	4 - 7

* Not suitable for pattern knitting unless special cards are used.

5. Operation dials

Adjust these dials for each of the various types of knitting as indicated on the panel.

* Left hand dial:

STITCH TENSION: Dial must be in this position when moving stitch tension knob.

PLAIN: Will produce stocking stitch on all needles when carriage is moved from right to left.

SLIP: Selected needles knit normally, remaining needles do not move (forming slip stitch pattern) when carriage is moved from right to left.

TUCK: Selected needles knit normally, remaining needles only come forward enough to catch a loop of yarn when carriage is moved from right to left.

* Right hand dial:

TWO COLOR: Selected needles knit yarn in thread mouth B, remaining needles knit yarn in thread mouth A. Use when

left hand dial set on plain knitting.

PLAIN: Will produce stocking stitch on all needles when carriage is moved from left to right.

SLIP: Selected needles knit normally, remaining needles do not move (forming slip stitch pattern) when carriage is moved from left to right.

TUCK: Selected needles knit normally, remaining needles only come forward enough to catch a loop of yarn when carriage is moved from left to right.



6. Returning lever

I: Normal knitting. Also used to bring needles from F position back to B position.

II: Use when some needles are holding stitches in F position - for shaping horizontal darts or for working one part of garment at a time.

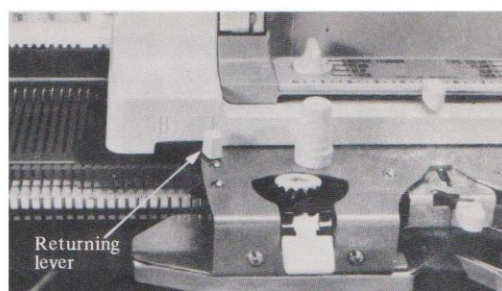

7. Needle selection lever

Back position (away from operator):
Needle selection does not operate, plain knitting is worked.

Forward position (nearest to operator):
Needle selection operates for pattern knitting.



8. Card feed dial

For inserting punched card and feeding or reversing card manually.
(To move this dial manually, pattern switch must be on "≡" position).



9. Pattern switch

- : Pattern knitting
- ≡ : Plain knitting



10. Card feed switch

- : Card feeds automatically
- ◐ : Card remains in same position

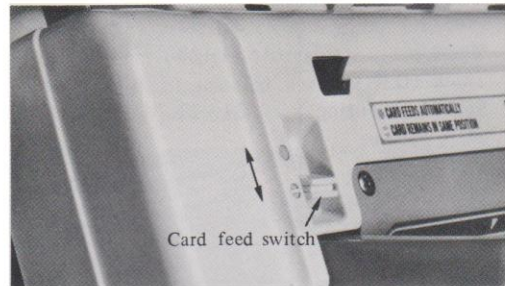

11. Accessory tray

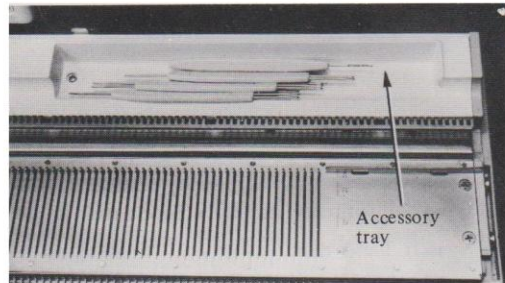

12. Needle selection indicator window

In this window, 24 small plates indicate needle selection position. Needles corresponding to plates which are pushed back are selected on previous row.

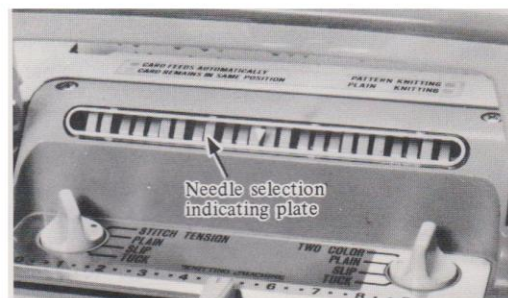

HOW TO KNIT PLAIN KNITTING

1. Preparation of knitting

1) Preparation of knitting yarn.

Yarn should be wound on a wool-winder* and the thread drawn from the center of the ball.

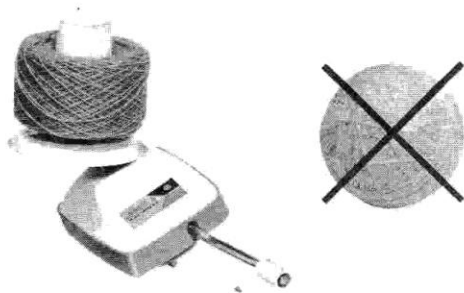

2) Stand yarn at back of machine.

- A) Take the yarn up through the yarn guide A.
- B) Insert the yarn between the rear yarn guide and tension disc.
- C) Take the yarn through the tension disc to the yarn guide B.
- D) Slip the yarn through the end of tension spring and down under the yarn clip to hold it until required.

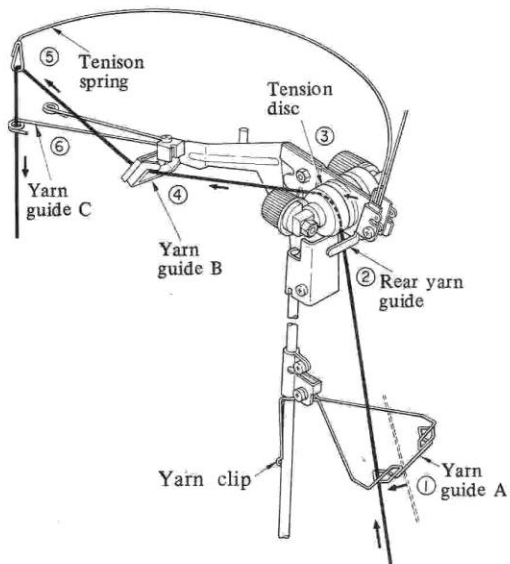

3) Adjust yarn tension control dial.

Yarn	Graduation
Extremely fine	5 - 6
Medium fine	3 - 4
Normal thickness	1 - 2

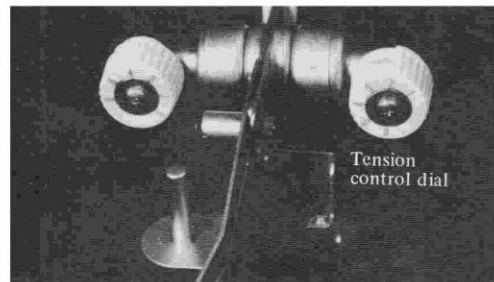

- 4) Turn the left operation dial to "STITCH TENSION" and move stitch tension knob to 2 whole numbers larger than required for plain knitting. (See paragraph 4 on page 6)

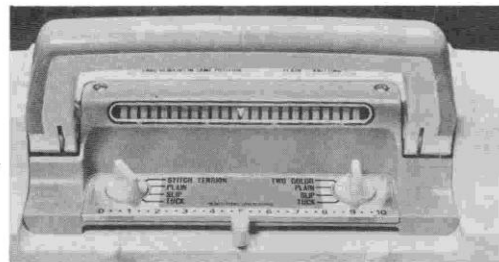

- 5) Set right and left operation dials to "PLAIN": Pattern switch on "≡" and Card feed switch on "●".



- 6) Put the needle selection lever to the back position.



- 7) Returning levers on "I".

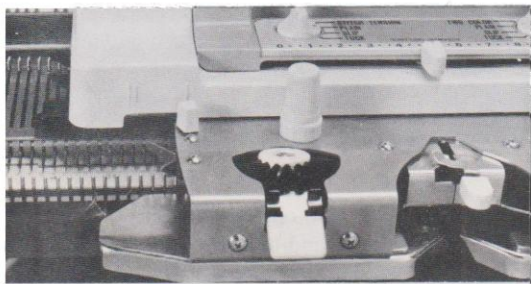

- 8) Bring out 60 needles to "B" position (30 needles each side of center "0").

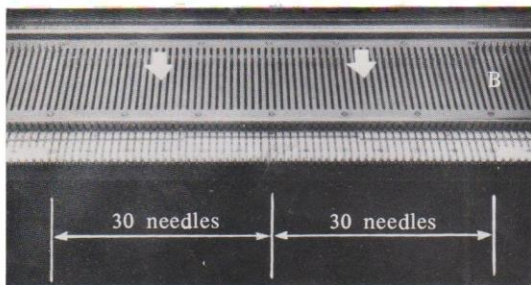

- 9) Arrange needles evenly in "B" position by taking the carriage slowly across and back finishing with carriage at right hand side of needle bed.

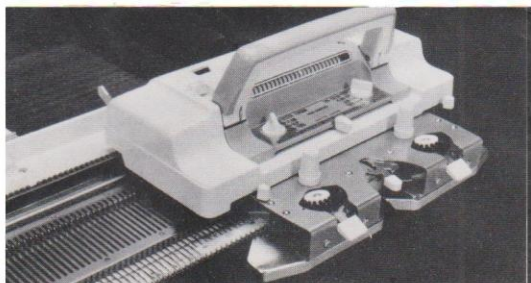

2. Casting on

- 1) Remove the yarn from the yarn clip.

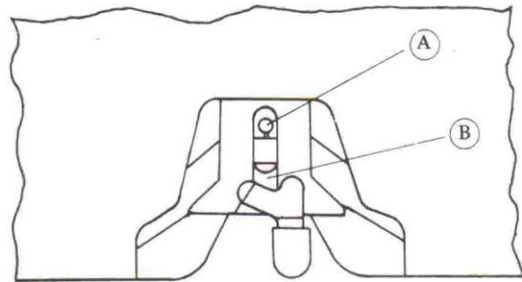

- 2) Push thread presser knob to left and slide knitting yarn into thread mouth A. Push thread presser knob back to right.

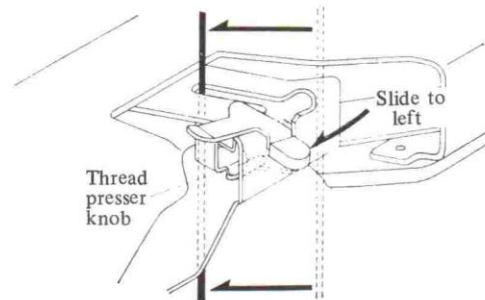

- 3) Take carriage slowly to left holding the end of yarn down with the left hand.

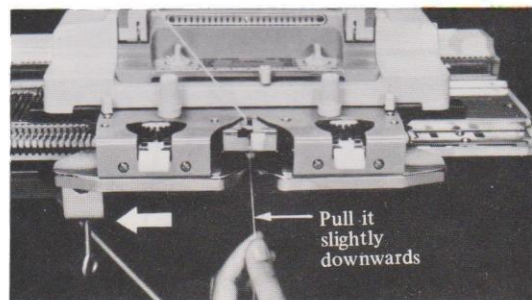

- 4) Leave carriage about 10 cms (4 ins) past the end needle at the left. Hold the end needle back to ensure that the yarn is not pulled tight on this needle.

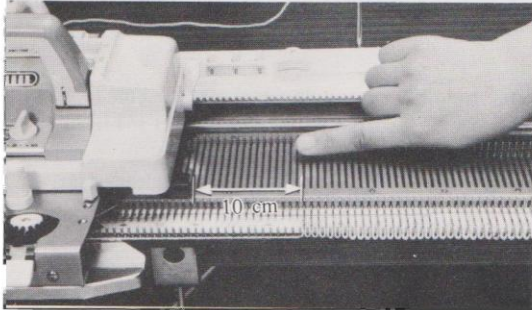

- 5) Take length of removable cord and lay it between needle hooks and sinkers.

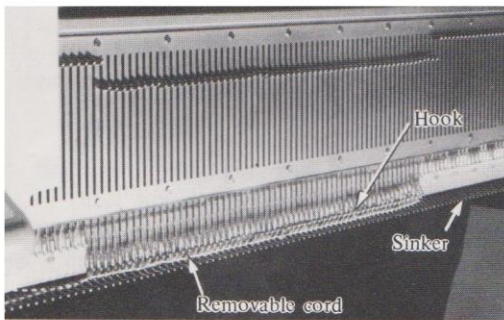

- 6) Holding both ends of the cord down firmly with the right hand knit one row. Read paragraph 8 before knitting this row.

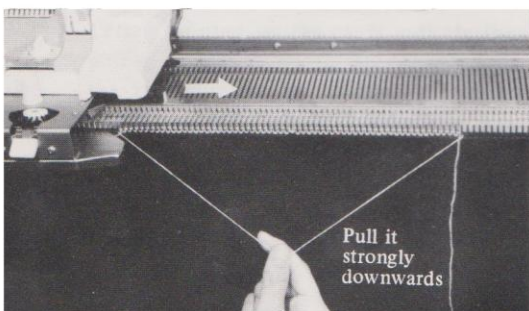

- 7) With left hand operation dial on "STITCH TENSION" move the stitch tension knob to the number suitable for the yarn thickness (see paragraph 4 on page 6). Reset operation dial on "PLAIN".

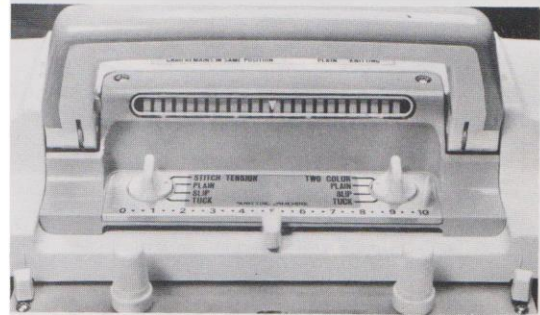

- 8) Move carriage until carriage has completely cleared the last needle - the sound changes when this has happened. Do not push carriage back in other direction until row has been completed or carriage will jam. Continue knitting for a few more rows.



- 9) After knitting about 10 rows, pull out the removable cord. Now cut short the end of yarn under the knitting so that the knitting will not unravel through this thread being pulled accidentally.

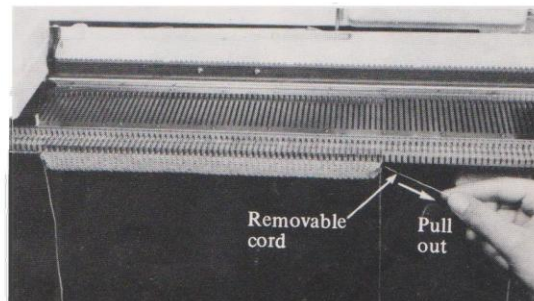

3. Waste knitting

- 1) Insert removable cord in thread mouth A instead of knitting yarn and knit one row.



- 2) Remove removable cord from thread mouth A and insert yarn for main knitting. Start knitting again.
- 3) First 10 rows are waste knitting for the purpose of casting on.
One row knitted with removable cord is to distinguish main knitting from waste knitting.
After knitting is completed pull out removable cord.

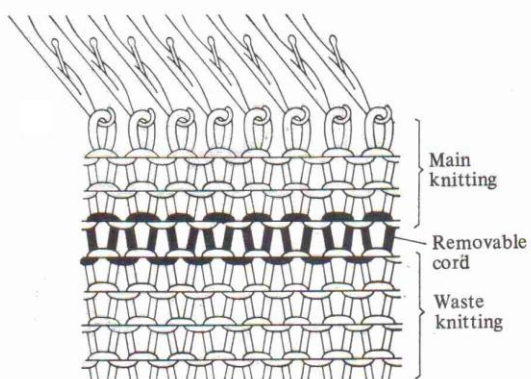

HOW TO KNIT PATTERNS

1. Memory card

For two-color knitting, slip stitch patterns, tuck patterns, weaving patterns and lace patterns use one of the memory cards.

List at end of this book shows which card can be used for the various stitch patterns.

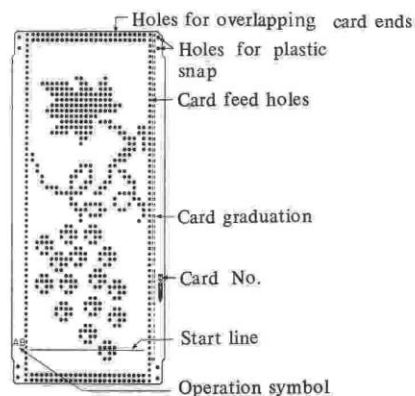

* Holes for overlapping card ends:

These holes must be matched together when one end of the card overlaps the other and are held by plastic snap so that the card can turn continuously.

* Card feed holes:

These are the guide holes to move the memory card.

* Start line:

Set this line just level with card entry.

* Operation symbols (A, B, C, D, E, F):

Letters printed on the cards indicate the points at which colors are changed in the two-color patterns. The first letter shows the yarn in thread mouth A, the second letter the yarn in thread mouth B; eg AB= color A in thread mouth A, color B in thread mouth B. AC shows that the yarn in thread mouth B must be changed to color C.

* $\leftarrow \rightarrow$: Move the lace carriage from right to left or left to right.

2. Relation between memory card and needle

Patterns of memory card appears at every 24 stitches on the line under needles. Center of pattern is indicated by the mark "▼".

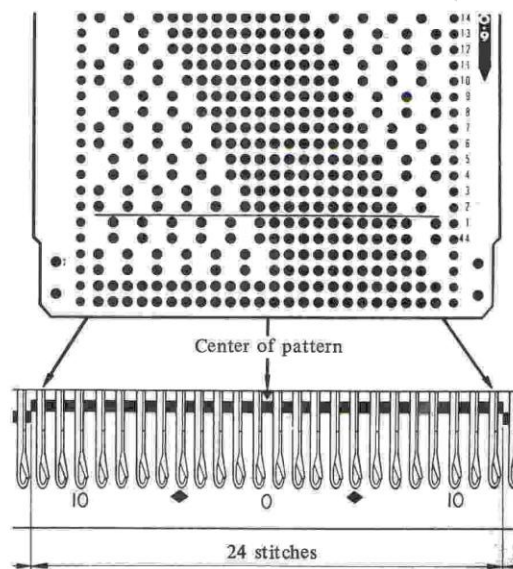

3. How to set memory card

1) Insert the card support **firmly** in the groove at the back of the carriage cover. If inserted loosely, it causes card feeding miss.

Note: Keep the cover of support opened.



2) Set pattern switch to "≡".

- 3) Insert memory card into slot. Take care that card is inserted correctly so that card remains level during operation. Marks "▲" on edge of slot show position where card feed holes should be.

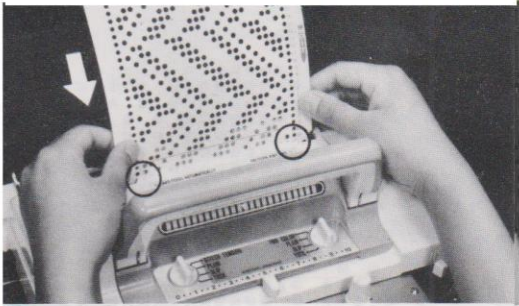

- 4) Rotate card feed dial towards you so that number "30" on card shows above entrance to slot.

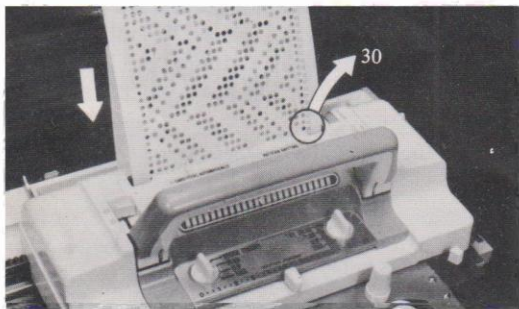

- 5) Overlap the card ends with the side nearest to you on top of the other end. Match the pairs of holes at each end and secure with a plastic snap each side.



- 6) Turn card feed dial so that the start line comes level with entry to slot. Number "1" on card is now shown in the starting position.

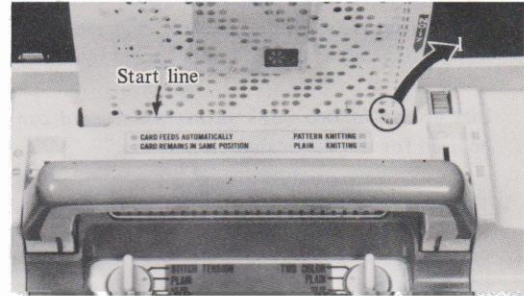

- 7) Close cover of card support.

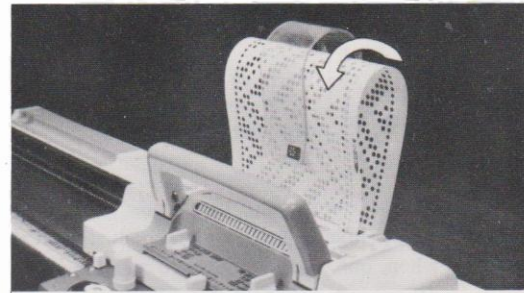

4. Preparation for pattern knitting

- 1) Knit 8 to 10 rows of waste knitting.
- 2) Knit one row with removable cord.



3) Set memory card at starting position.

Note: To feed card by hand, set pattern switch on "≡".

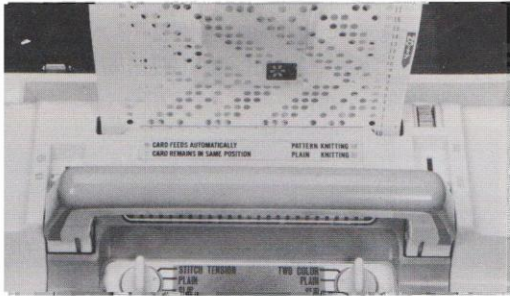

4) Change to main yarn and set carriage as follows:

Card feed switch: "●"

Pattern switch: "■"

Needle selection lever: "PATTERN"

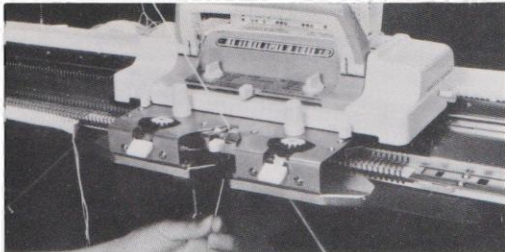

5) Knit one row slowly.

Needles are now selected according to the punched holes of the first row of the memory card. (If this row is a plain row no needles will be selected).

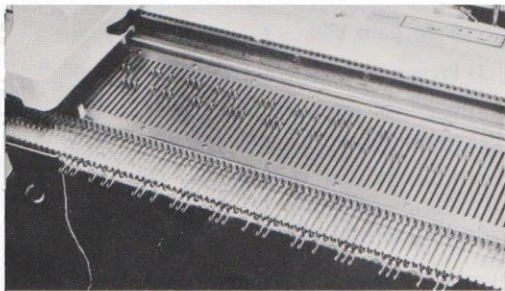

6) Set card feed switch to "●".

7) Set operation dial to the pattern you have chosen.

5. Pattern knitting

* Two color pattern

1) Take memory card No. 1.

2) Prepare yarn for main color and 2 contrast colors.

3) Prepare for pattern knitting as indicated in previous section up to and including (6).

4) Set stitch tension according to the yarn being used. Set left operation dial on "PLAIN" and right dial on "TWO COLOR".

5) Knit two rows with main yarn in thread mouth "A". As the second of these rows is knitted the needles which will be knitted in contrast color on the following row are brought forward to D position.

The card has moved down and now shows "3" at right and at the left the indication "AB" shows that color A will be in thread mouth "A" and color B in thread mouth "B".

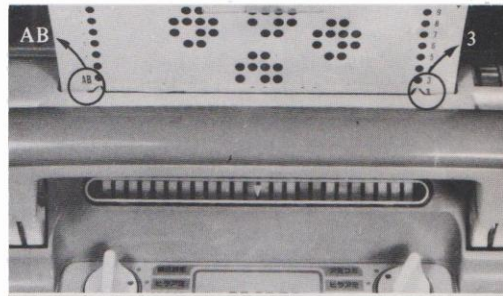

6) Thread the contrast color yarn through the other tension arm and down through thread mouth B.

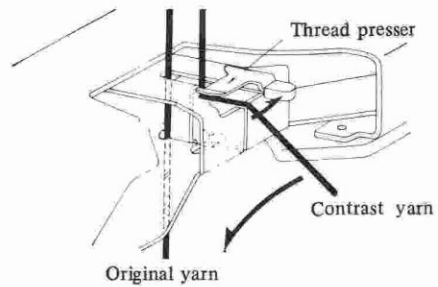

7) Set tension 2 degrees looser.

8) Holding the end of the contrast yarn until the first row is knitted now knit until number "28" on memory card shows above entrance to slot.

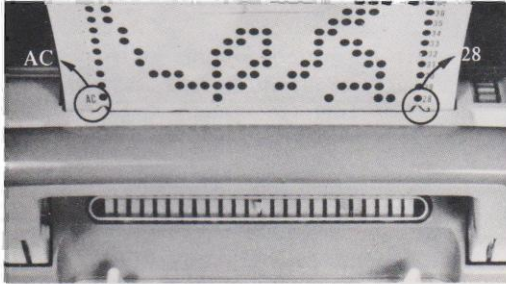

9) When number "28" shows at right, "AC" shows at left. This indicates that color "C" should now be used in thread mouth B. Continue knitting until "55" shows at right and "A" shows at left. Now continue knitting with color A only and stitch tension as for first 2 rows.

Note: It is not always necessary to change the stitch tension for rows of plain knitting which are worked between sections of two-color knitting. Experience will show when this is required, but generally two-color knitting is tighter in width (more stitches to the inch), and looser in length (fewer rows to the inch) than for plain knitting.

* Slip stitch pattern

- 1) Use card No. 17 and prepare for pattern knitting as before.
- 2) Set the stitch tension at 2 degrees looser than for same yarn in plain knitting.
- 3) Set the left and right operation dials to "SLIP".

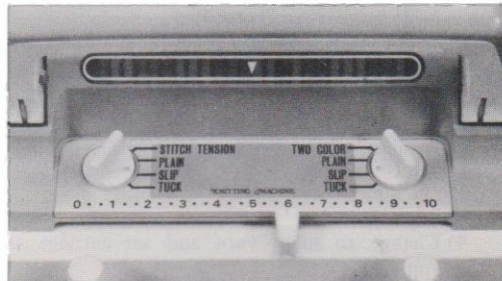

Note: To ensure a firm straight edge always ensure that the needle at each end of work is brought out to D position before knitting the row.

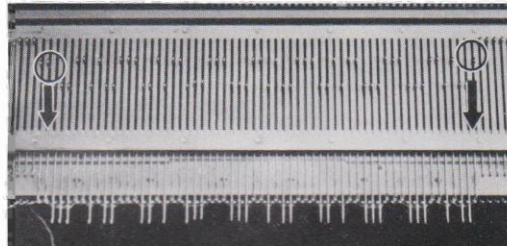

* Colored slip stitch pattern

- 1) Use card No. 9.
- 2) Prepare two different color yarns. Thread color A through thread mouth A leaving color B in yarn clip.
- 3) Prepare for pattern knitting as before.
- 4) Set the left and right operation dials to "SLIP".
- 5) Knit 2 rows then remove color A and replace with color B. Knit 2 rows. Repeat these 4 rows.

For slip stitch pattern, hung weights at both ends of material under knitting.
(See paragraph 11 on page 19).
If weights become so low after knitting proceeded, hung weights upper again.

* Tuck pattern

- 1) Use card No. 15 and prepare for pattern knitting as before up to and including paragraph (6) on page 15.
- 2) Set the stitch tension at 1 or 2 degrees tighter than for same yarn in plain knitting.
- 3) Set the left and right operation dials to "TUCK".

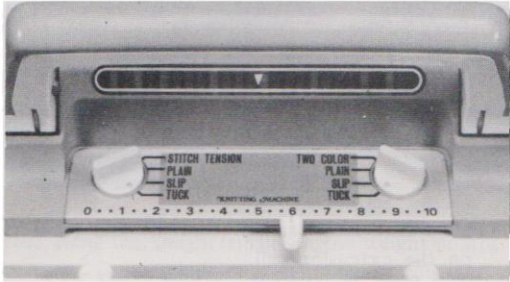

Note: To ensure a firm straight edge always ensure that the needle at each end of work is brought out to D position before knitting the row.

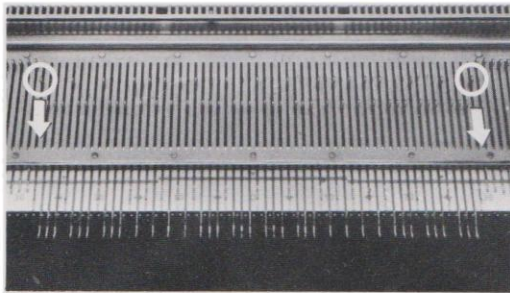

* Color tuck pattern

- 1) Use card No. 8.
- 2) Prepare two different color yarns. Thread color A through thread mouth A leaving color B in yarn clip.
- 3) Prepare for pattern knitting as before.
- 4) Set the left and right operation dials to "TUCK".
- 5) Knit 2 rows then remove color A and replace with color B. Knit 2 rows. Repeat these 4 rows.

For tuck stitch, hung weights at both ends of material under knitting.
(See paragraph 11 on page 19).
If weights become so low after knitting proceeded, hung weights upper again.

* Weaving pattern

- 1) Use Card No. 13.
- 2) Prepare the main knitting yarn (medium/fine) and weaving yarn (much thicker).
- 3) Prepare for pattern knitting as before with main yarn in thread mouth A and weaving yarn in yarn clip.
- 4) Set the stitch tension according to the yarn being used for the main knitting.
- 5) Set the left and right operation dials to "PLAIN".
- 6) Push the weaving knobs upwards.

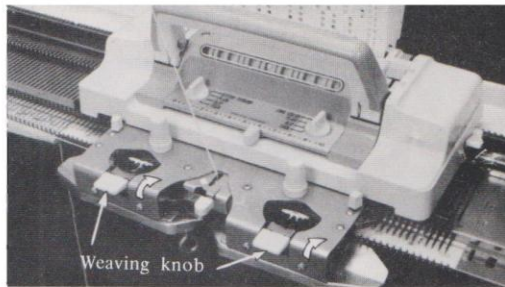

- 7) Bring out the needle nearest the carriage to D position.

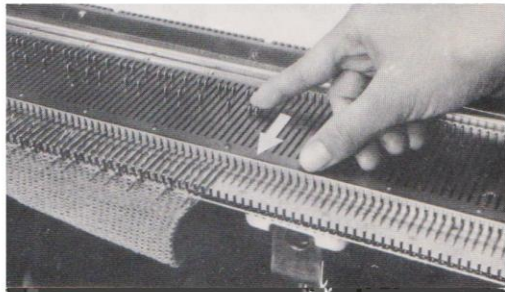

Note: Repeat this operation on every row to keep the edge straight.

- 8) Take the weaving yarn from the yarn clip and holding it as illustrated close to the sinkers, knit one row.

The weaving yarn slips into the weaving guide.

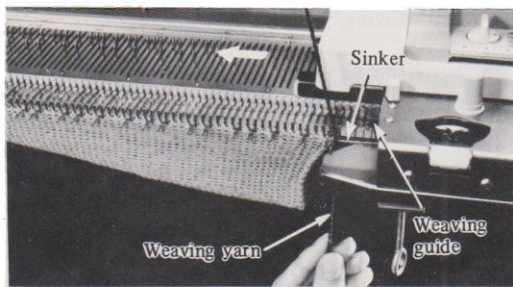

- 9) Remove the weaving yarn from the guide and take it to the other side. Move the carriage and again the weaving yarn slips into the weaving guide.

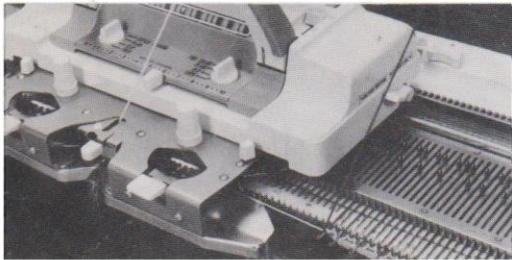

- 10) Always remember to bring the needle nearest to the carriage to D position at beginning of each row.

* Lace pattern

- 1) Remove the carriage stopper from the left and right side plates and attach extension rails.

Hold the extension rail slantwise and insert tip of bent parts to the hole in the front plate. At the same time insert the tip of other side under the pin. Fix the extension rail by pressing down.

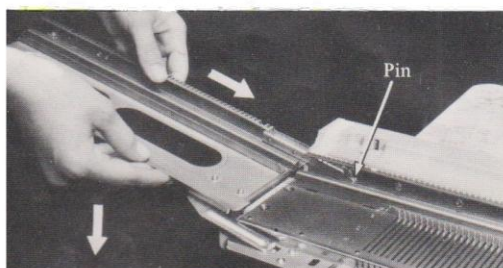

- 2) Pull up lace carriage handle.

- 3) Pull the lock button of lace carriage towards you and put the rear plate into the guide rail.

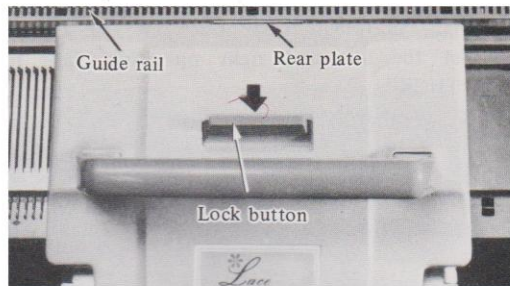

- 4) Move the lace carriage to right and leave it on the extension rail.

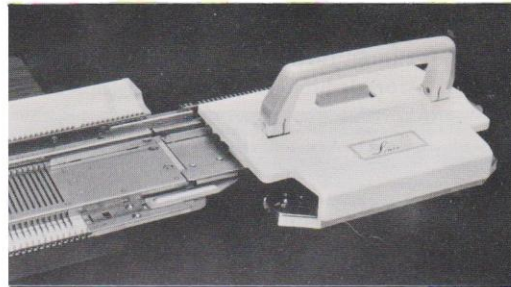

- 5) Adjust the stitch tension according to the yarn to be used remembering that thick yarn are not suitable for lace knitting.

- 6) Set the left and right operation dials to "PLAIN".

- 7) For using yarn which is not smooth, put paraffin wax in the shaft.



8) Using waste yarn knit a few rows ending with carriage at left.

9) Pull out the wire from the weight comb, then insert the comb up through the knitted material and thread the wire through again.

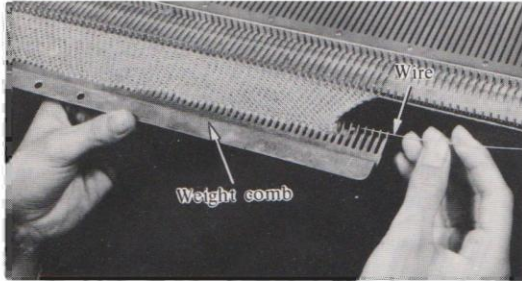

10) Hang the weight (small) on the weight combs.
Note: Place weight centrally to keep balance even.

11) Hang the weight (C) at each side of knitted cloth about 3 or 4 cms (1 or 2 ins) below the sinkers.

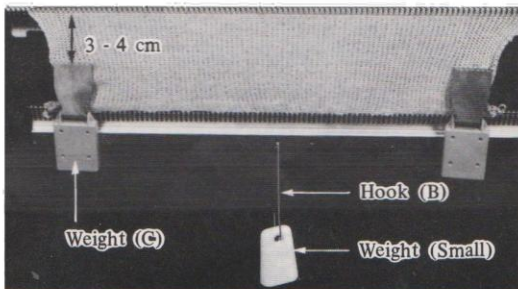

12) Use card No. 18 and prepare for the pattern knitting up to and including paragraph (6).

Note: Move carriage from left to right for paragraph (5) of preparation of pattern knitting.

13) Knit 1 row (from right to left). Number "2" now shows at right of card and "←" shows at left.



14) If the needles at either end of knitting are selected, return them to B position.

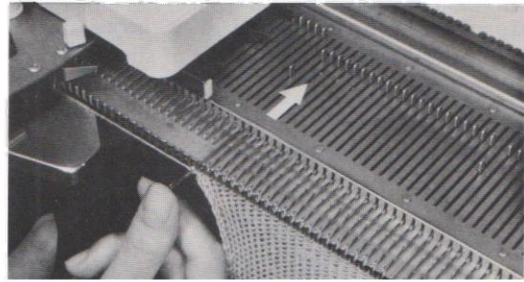

15) Move the lace carriage from right to left (as indicated by "←" on card). You will see that the stitches which were on the selected needles have been transferred to an adjacent needles.

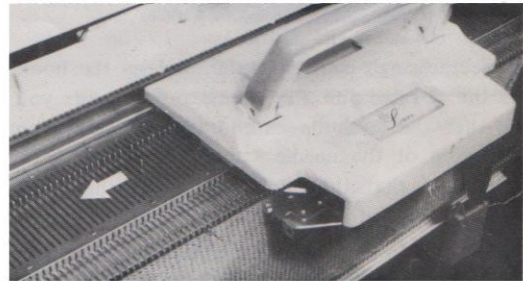

16) Move the lace carriage back to the right and leave it on the extension rail.

17) Knit 2 rows with the knit carriage ending with carriage at left. The needles will be selected as before. Operate the lace carriage in direction of arrow mark as before.

18) When the direction of arrow mark changes, push the knit carriage onto the extension rail, remove the lace carriage and place it at other end of needle bed, then move it in the direction of the arrow mark.

When moving the lace carriage, make sure that the rear plate is correctly placed on the guide rail.

Note: To remove the lace carriage, pull the lock button towards you.

19) As the knitting progresses re-hang the weights from time to time.

INCREASING AND DECREASING NUMBER OF STITCHES

To shape knitted material it is necessary to decrease or increase the number of stitches being knitted.

Note: Before starting this lesson, please practice transferring stitches.



Place the single-ended transfer tool on the hook of the needle, pull the needle out towards you so that the latch opens and the stitch lays on the stem of the needle. Push the needle back firmly so that the latch closes and the stitch slides onto the transfer tool. Holding transfer tool so that stitch slides down towards handle now remove tool from needle.

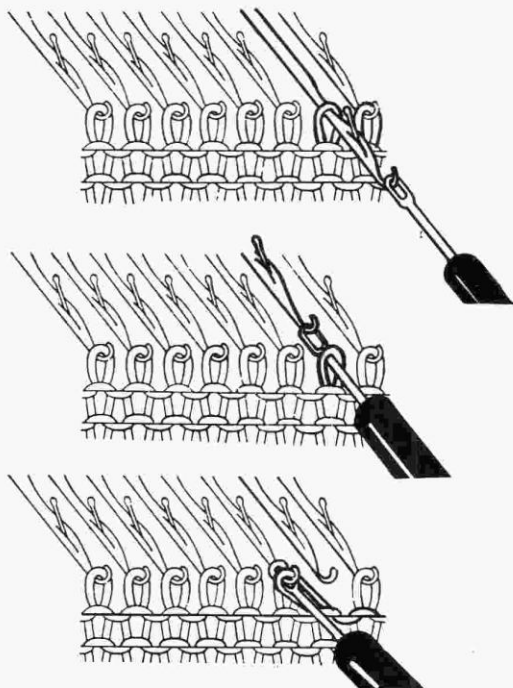

1. Increasing one stitch

- 1) Bring 1 needle up from A to B position on the side where the increase is required.
- 2) Using the transfer tool transfer the edge stitch onto the empty needle.
- 3) Lift the loop below the stitch on the 3rd needle and place it onto the empty needle.

* Knit 2 or 3 rows and practice the increase by repeating these steps.

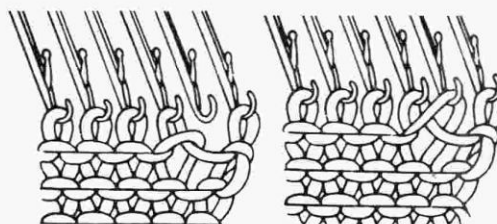

2. Decreasing one stitch

- 1) Using the transfer tool transfer the end stitch onto the 2nd needle.

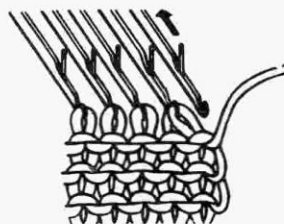

- 2) For a fully fashioned edge use the 2 or 3-stitch transfer tool to move the end 2 or 3 stitches 1 needle in.
- 3) Return empty needle to A position.

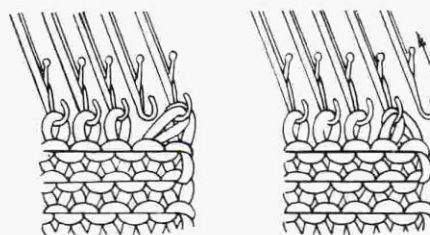

3. Increasing more than two stitches (casting on by hand)

- 1) Leave the carriage on the side where the stitches are to be cast on. Bring out to F position the required number of needles.
- 2) Wind the yarn round each needle as illustrated.

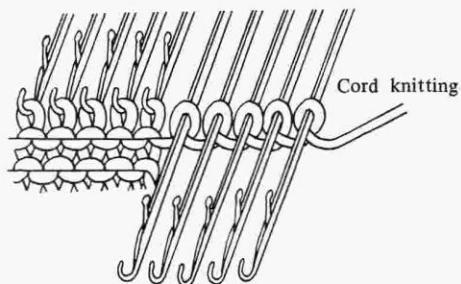

- 3) Set returning levers on "I" and knit one row.
- 4) Push the needles with new stitches forward to F position once more and knit one row.

4. Decreasing more than two stitches

*** First Method (Simple casting off)**

This is always done on the same side as the carriage.

- 1) Bring the end needle forward so that the stitch slips behind the latch. Take the yarn over the needle in front of the latch and pull the needle back to B position thus knitting the stitch.

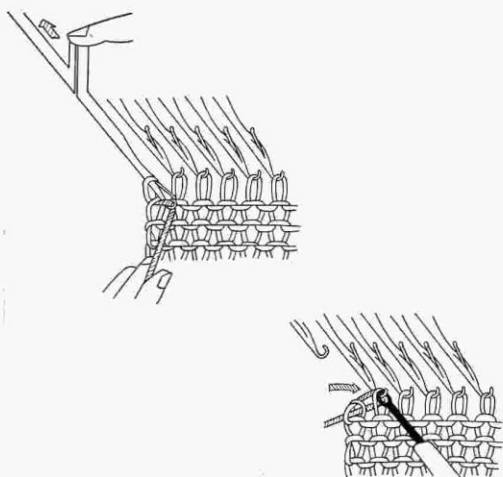

- 2)* Using the single-stitch transfer tool transfer this stitch onto the second needle and push the empty needle back to A position. Bring the needle forward so that both stitches are behind the latch, take the yarn over the needle and pull the needle back thus knitting the two stitches together, repeat from * until required number of stitches are cast off.

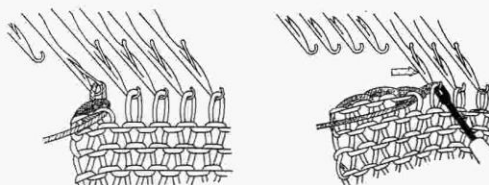

*** Second Method (Chain casting off)**

- 1) If all stitches across the row are to be cast off, knit one row at very loose tension. If only a few stitches are to be cast off, knit these through loosely by hand.
- 2) Starting at side away from end of yarn hold the work down firmly with the left hand and using the latch needle tool slip the first stitch onto the tool and off the needle.
- 3) *Push the tool forward so that the stitch lays behind the latch, keeping it in this position take the stitch off of the next needle and pull it through the stitch on the tool; repeat from * replacing the empty needles in A position as required.

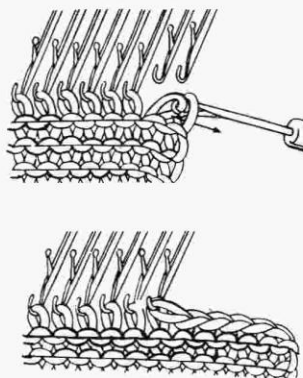

VITAL POINTS TO REMEMBER IN KNITTING

1. Horizontal shaping

Horizontal shaping is used wherever more rows are required at one side or other of the work or at the center, for example, in the case of bust darts, shaped hems or shoulder shapings. There are two main methods of working depending on the final shape required, for example, a shaped hem at the bottom of a skirt requires the curve to be lower at the center whereas a bust dart requires the curve to be higher at the center and shoulder shapings which are worked in much the same way as a bust dart require the slope to be higher at the neck edge of the shaping.



- 1) Shaped hems (or any shaping where the curve slopes up towards the side edges).

Note: The example is given over a small number of stitches to enable you to practice this form of shaping without wasting a lot of yarn. The principle is the same regardless of the number of stitches being used.

- a. Using the main yarn cast on 30 stitches by hand and knit ten rows for the hem.
- b. Set left and right returning levers on "II" position.
- c. Push 12 needles at side furthest from carriage into F position and knit one row. Only the needles in B position will have knitted, the yarn will lay across the stems of the needles in F position.

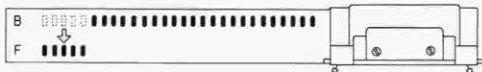

- d. Take the yarn under the inside needle in F position.

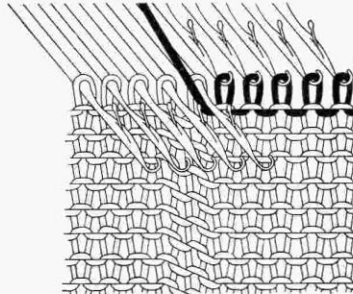

- e. Repeat steps c and d.
- f. Bring four needles nearest to carriage on opposite side back to D position and knit one row. Bring the yarn under the inside needle in F position.

Note: If this is not done on every row a hole will be made.

- g. Repeat the last step until all needles are in B position.
Set left and right returning levers to "I" position and continue knitting. After the knitting of the skirt is completed and the side seams have been sewn together, you will see that the rows knitted for the hem curve round with the shaping to form a neat edge which can be folded up and slip stitched in place.

- 2) Horizontal shaping for a bust dart (or any shaping where the curve is required to slope downwards towards the side edges).

- a. Cast on 40 stitches and knit a few rows.
- b. Set left and right returning levers on "II" position.
- c. Push four needles at side opposite to carriage to F position and knit one row. Take the yarn underneath the inside needle in F position.
- d. Repeat step c, five times more.

- e. Push needles at side opposite to carriage back to D position and knit 1 row.
- f. Push both returning levers to "I" and knit one row. All the needles are back in B position. Continue knitting as required.

3) Shaping required at one side edge of work only (for example, where the shaped hem is required on the front of a jacket or coat which has been shaped on both sides at the back):

- a. Cast on 15 stitches by hand and knit 10 rows in stocking stitch.
- b. Push 12 needles at side furthest from carriage into F position. Take yarn under inside needle in F position and knit two rows.
- c. Push 4 needles back to D position and knit 2 rows. Take yarn under inside needle in F position. Repeat last operation twice more. All needles now returned to B position.
- d. For shaping of bust dart or shoulder on one side of work only, cast on 20 stitches and knit a few rows. Push 4 needles at side opposite to carriage into F position and knit two rows. Take yarn round nearest inside needle in F position. Repeat the last operation twice more. Push returning levers back to "I" position and continue knitting on all needles.

4) Horizontal shaping of lace knitting.

Lace knitting can be shaped horizontally by making use of the slip stitch mechanism to knit the rows between the operation of the lace carriage.

- a. Set left and right operation dials to "SLIP".
- b. Bring out all B position needles to F position.

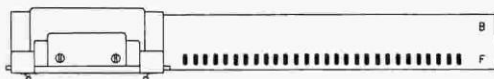

- c. Knit one row, thus leaving needles in B position and D position ready for operation of lace carriage.

Note: If next row is a plain row all needles will be in B position.

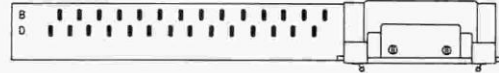

- d. If any of the needles which should not be knitted on the next row have been selected, take them back to B position.

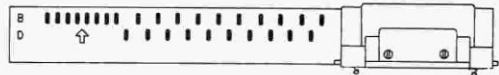

- e. Move the lace carriage according to the arrow on the memory card.

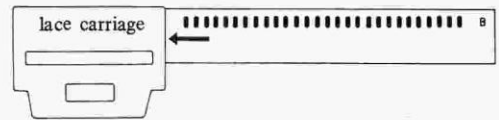

- f. Bring all the needles which are to be knitted to F position.
- g. Repeat steps b-f until shaping is completed after which set both operation dials at "PLAIN" and continue lace knitting as normally.

Note: At the case unknit parts is increased at carriage side, arrange yarn as follows:

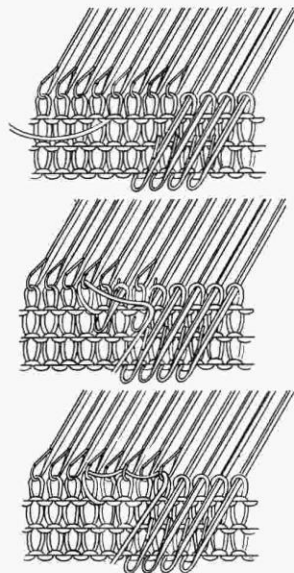

2. Rib knitting

1) Rib knitting.

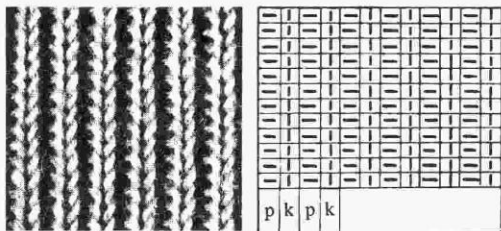

Knitting code

- a. Cast on by hand and knit as many rows as required in stocking stitch but using a stitch tension one or two numbers tighter than for normal stocking stitch.
- b. Place the latch needle tool into the third stitch from the end on the cast-on row.
- c. Slip the third stitch from the end off the machine needle and allow it to run down until it is caught on the hook of the latch needle tool.

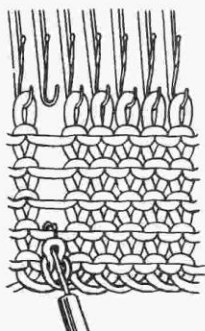

- d. Push the latch needle tool forward so that the stitch lays behind the latch.
 - e. Catch the horizontal thread above the stitch into the hook and pull the tool backwards. The latch will close and you can draw the thread on the hook through the stitch thus making a new stitch.
- Repeat steps d. and e. to the top of the work.

- f. Transfer the knitting stitch to the empty needle on the machine.

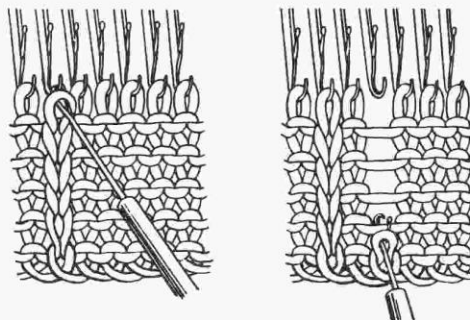

- g. Miss the next stitch then repeat from step b. on next and every alternate stitch.
- h. Continue in this way on every alternate stitch across the work. This has now formed 1 x 1 ribbing.

2) Finish of rib knitting.

If you wish to form a hand finish to rib knitting which will be as elastic as the ribbing itself, follow the instructions below.

- a. Cut yarn leaving a length 2.5 times the width of the knitting.
- b. Bring all needles to F position.
- c. Holding the knitting down so that stitches cannot drop transfer stitches onto a knitting needle as illustrated.

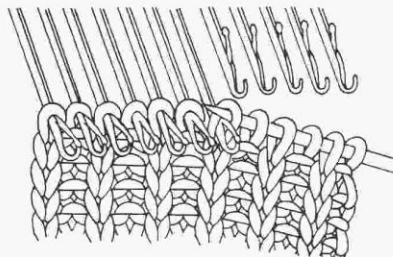

- d. Close the edge of the rib as illustrated using end of yarn threaded in seaming needle.

- a. Use 2 transfer tools with 3 needles each. Slip 3 of the stitches to be crossed onto each needle taking care to hold the needle upwards so that the stitches do not slip off.

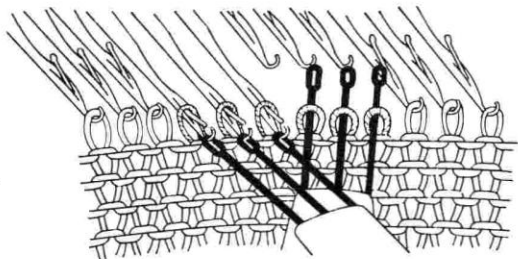

- b. Cross the needles over and slip the stitches from the left onto the 3 right hand needles.

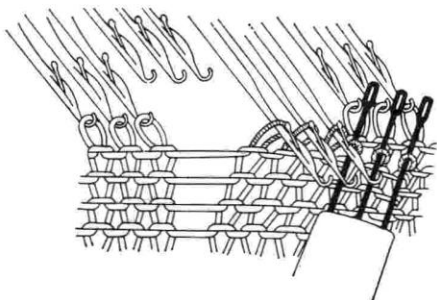

- c. Slip remaining stitches onto the other 3 needles.

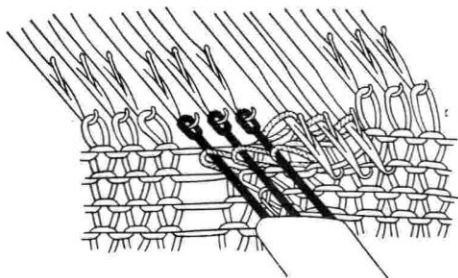

- d. Knit 9 rows.
- e. Repeat steps a. to d.

5. Cord or tube knitting

- a. Depending on the size of the cord, bring 3 or 4 needles to "F" position and cast on by hand.
- b. Set the right hand operation dial "SLIP".
- c. Set the stitch tension 2 degrees tighter than normal.
- d. Take the carriage across and back pulling the knitting down at first.

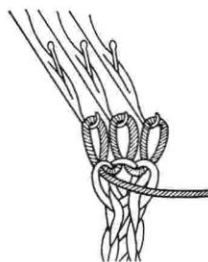
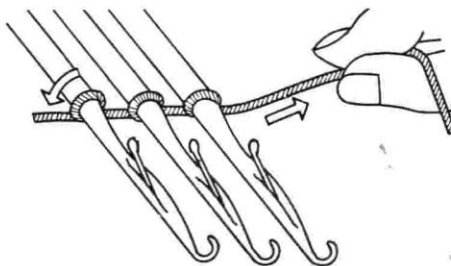

6. Casting off shoulder together

- a. Shape shoulder according to horizontal shaping instructions. Knit a few rows in waste yarn and slip work off machine.
- b. Knit second part of body in the same way and cut yarn at end leaving two and a half times the knitting width of yarn. Slip first part of body back onto machine with right side of work facing.
- c. Slip second part of body back onto same needles but with wrong side of work facing.
- d. Thread seaming needle with end of yarn and sew stitches together as illustrated.

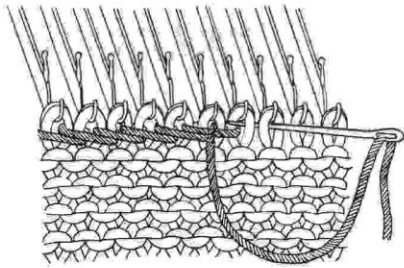
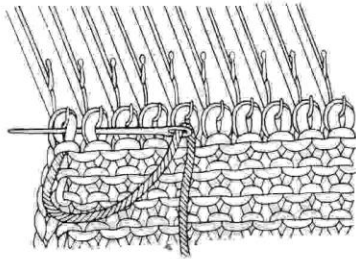
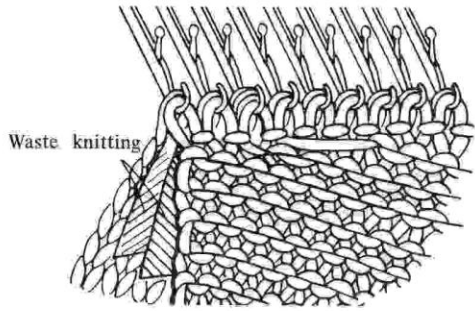

7. Grafting plain knitting

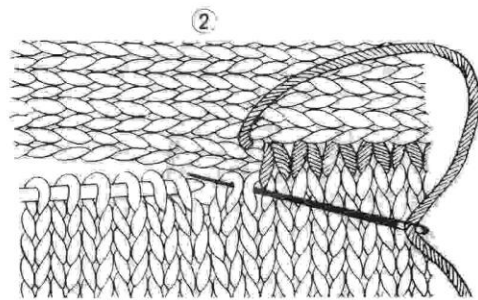
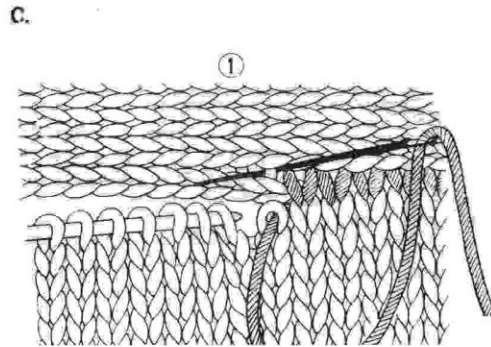
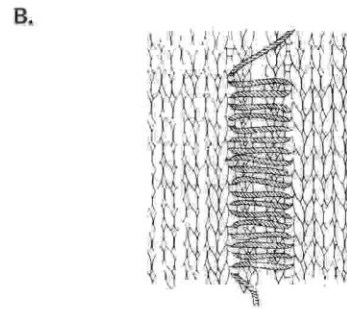
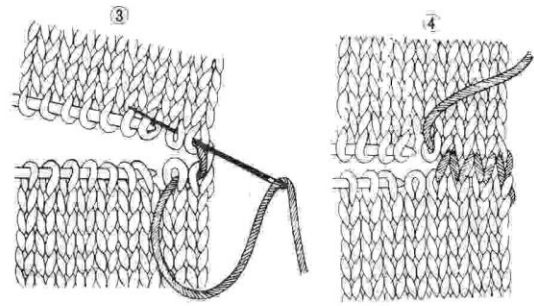
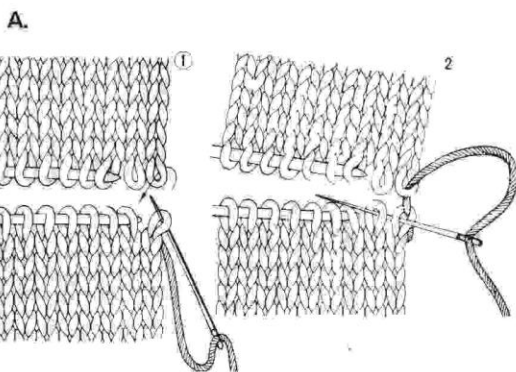

WHAT TO DO IN CASE OF DIFFICULTIES

1. Carriage jams halfway across row

1) Plain knitting.

a. Take off fabric press.

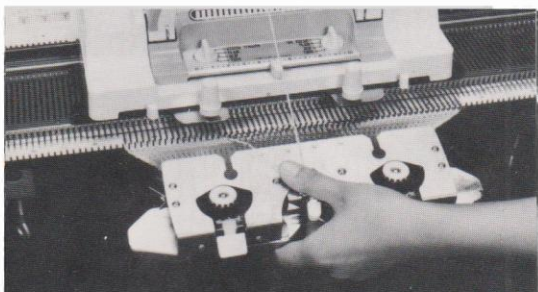

b. Push in row counter lever.

c. Lift up carriage at front and slide it back to starting position.

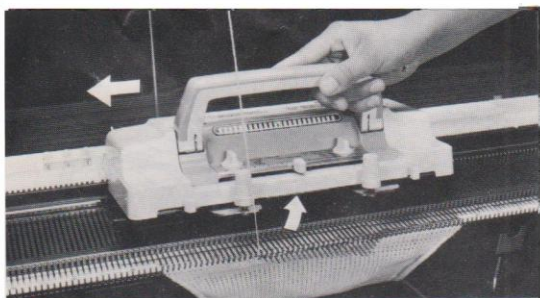

d. Reset fabric press.

e. Take yarn out of thread mouth.

f. Unravel row knitted halfway, and any additional rows if there is a mistake in the work.

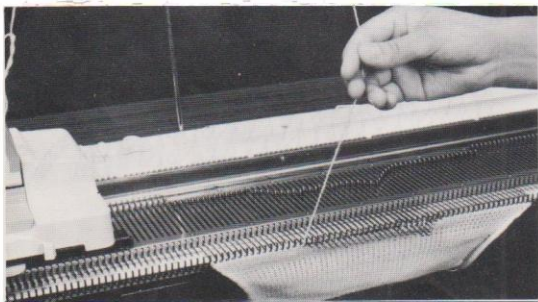

g. If row counter had moved, turn it back for the number of rows unravelled.

h. Pull out row counter lever.

i. Replace yarn in thread mouth.

2) Pattern knitting.

a. Take off fabric press.

b. Push in row counter lever.

c. Lift up carriage at front and slide it back to starting position.

d. Replace fabric press.

e. Take yarn out of thread mouth.

f. Unravel the row knitted halfway then unravel one more row so that the yarn is at side opposite to carriage.

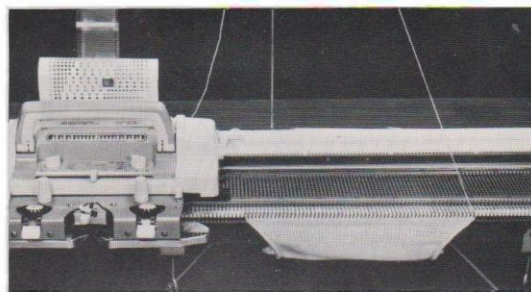

g. Set pattern switch to "≡" and turn memory card back 4 rows.

Reset pattern switch on "■".

h. Set operation dial on "SLIP".

i. Take carriage across to the side where yarn is attached.

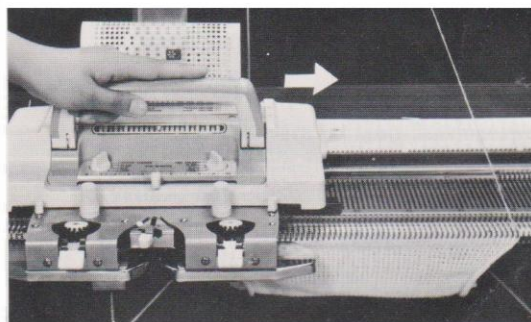

j. Replace yarn in thread mouth.

k. Reset row counter according to number of rows unravelled and reset operation dials on type of stitch being knitted.

2. Correcting a mistake

1) Plain knitting.

- a. Take yarn out of thread mouth.
- b. Unravel rows back to place where you wish to start again.

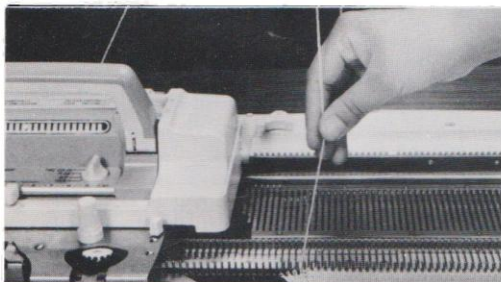

- c. Arrange needles in "B" position.
- d. If yarn is at the opposite side of carriage after unravelling rows, push row counter lever in, set operation dials on "SLIP" and move carriage to the side where yarn is attached.

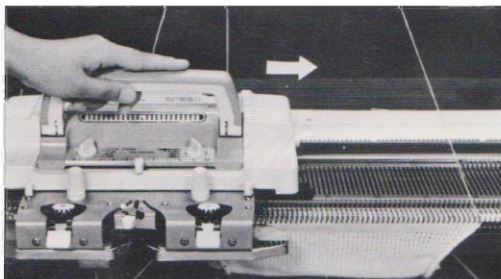

- e. Reset operation dials "PLAIN" and pull out row counter lever.
- f. Reverse row counter for number of rows unravelled. Replace yarn in thread mouth.

2) Pattern knitting

- a. Take yarn out of thread mouth.
- b. Unravel rows back to place where you wish to start again, finishing with yarn at side opposite carriage. (It may be necessary to unravel one more row for this purpose).

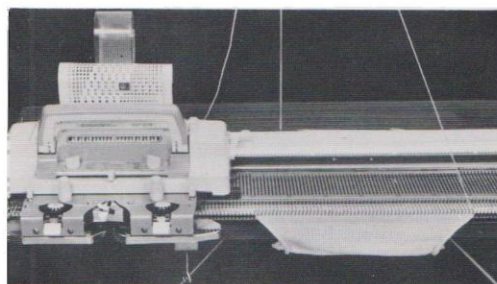

- c. Arrange needles in "B" position.
- d. Set pattern switch on "≡" and turn memory card back the number of rows unravelled plus one. (Eg if 4 rows unravelled turn card back 5 rows). Reset pattern switch on "■".
- e. Set operation dial on "SLIP".
- f. Push in row counter lever and move carriage to the side where yarn is attached.
- g. Set operation dial on to type of stitch. Pull out row counter lever
- h. Reverse row counter for number of rows unravelled. Replace yarn into thread mouth and reset operation dial on type of stitch being knitted.

3. How to unravel a row of stitches

- 1) Pull the yarn firmly so that the stitches of the previous row are lifted up onto the needles. Keep replacing a few stitches at a time in this way by pulling and moving the yarn backwards and forwards until the row is unravelled.
- 2) Take the carriage across without knitting (both operation dials to "SLIP").
- 3) Correct row counter and re-thread yarn.
- 4) Pull the yarn from behind the tension assembly to ensure that it does not become slack.

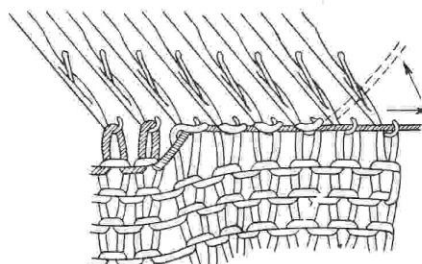

4. When a stitch slips down one row

- 1) Lift the dropped stitch and the yarn of row above onto the empty needle.

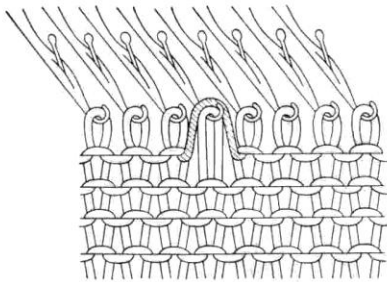

- 2) Hold the yarn of the row above with the single transfer tool, push the needle forward so that the stitch lays behind the latch. Drop the yarn down in front of the latch.

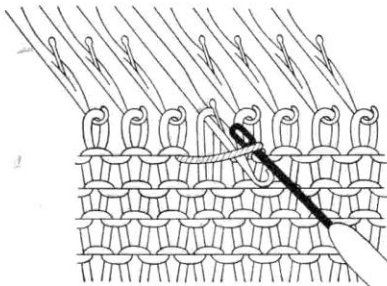

- 3) Pull the needle back to "B" position thus re-knitting the stitch.

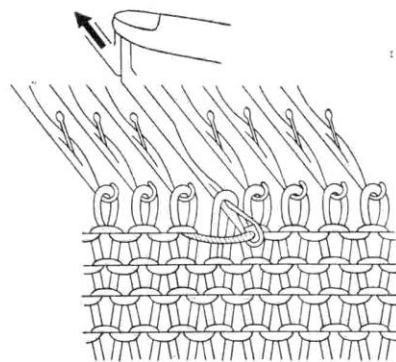

5. When a stitch slips down a number of rows

- 1) Hold the latch needle tool at the back of the work and push it through one row below the dropped stitch. Press down lightly so that the stitch is on the hook.

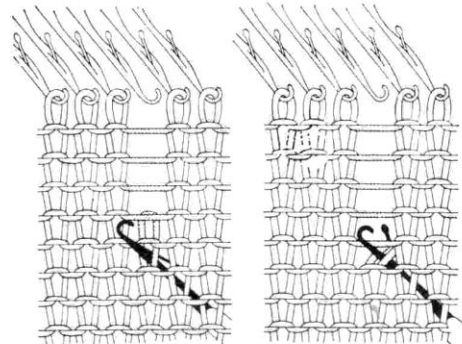

- 2) Push the latch needle tool forward so that the stitch lays behind the latch.
- 3) Catch the yarn of the row above into the hook and pull the needle back drawing the stitch through.
- 4) Repeat 2) and 3) until all the rows are knitted up.
- 5) Replace last stitch on needle.

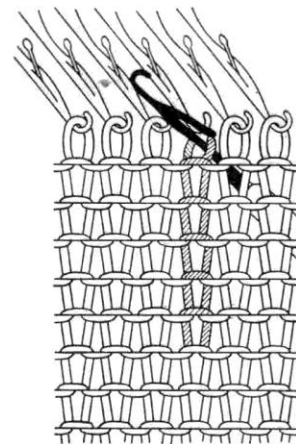

6. When knitting needles are damaged

- 1) Push needle bar with handle of the latch needle tool.

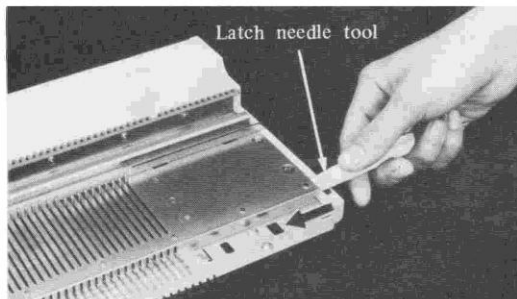

- 2) Catch the needle bar at the end of groove plate and pull it until the other end is just past the needle to be replaced.

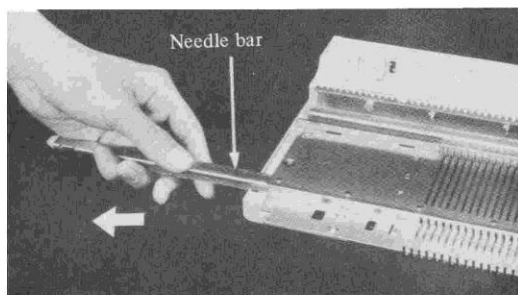

- 3) Push the needle to "F" position, then press the hook end downwards and the shank end will come up. Pull the shank end up and back until it is out of the plate.

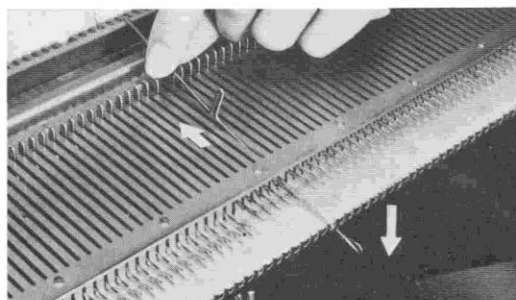

- 4) Insert new needle in the reverse order.

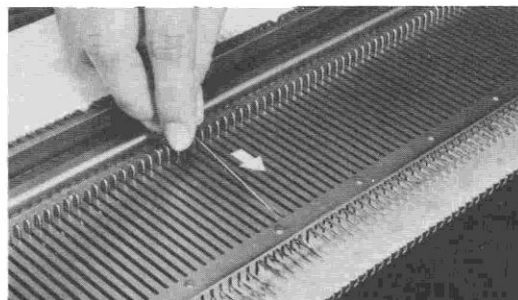

- 5) When the new needles is in place push the needle bar back as before at the same time keeping it in place by pressing forward on some of the needle butts.

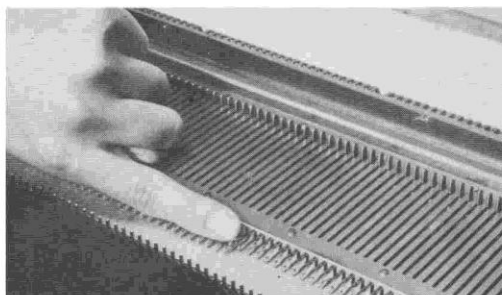

HOW TO USE CREATIVE PUNCH CARD

1. For the use when making patterns included in PATTERN BOOK 24 Vol. 1

- 1) Select the pattern of your choice from "PATTERN BOOK 24 Vol. 1".
- 2) Mark places on memory card where to punch hole.

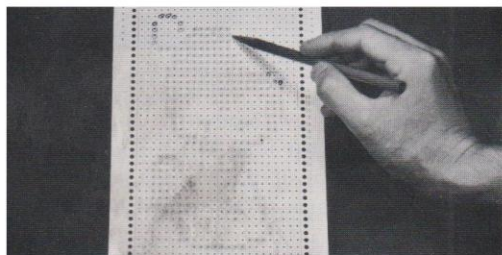

- 3) Punch holes. Mark "A" "AB" thus indicating yarn color changes if required, on memory card.

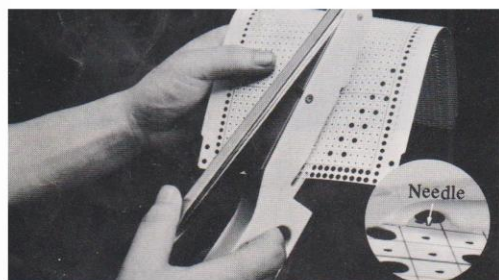

- 4) For a pattern of less than 60 rows, cut memory card as illustration.

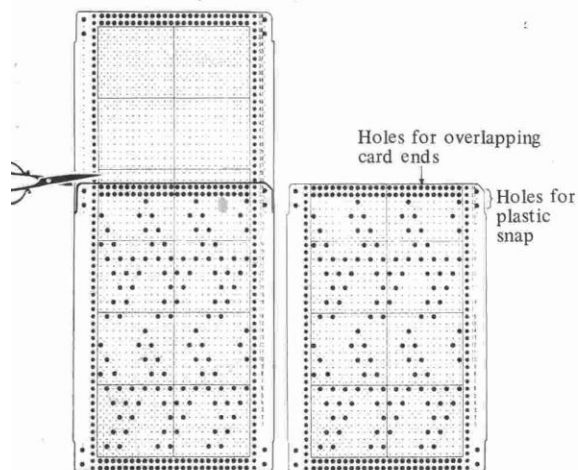

2. For the use when making your own pattern.

- 1) Design pattern on section paper.

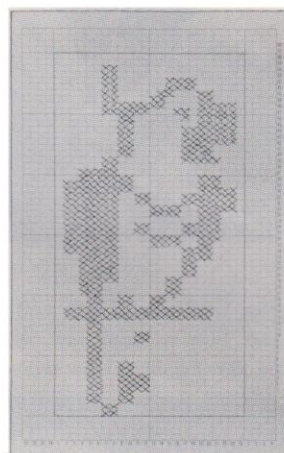

- 2) Relation between holes and knitting is as follows.

	PUNCHED HOLES	UNPUNCHED
TWO COLOR	Needle knits yarn in thread mouth B	Needle knits yarn in thread mouth A
SLIP	Needle knit normally	Needle does not move yarn lays across front of work
TUCK	Needle knits normally	Needle comes forward enough to catch new loop of yarn still holding old stitch
WEAVING	Weaving yarn lays over needle	Weaving yarn lays under needle
LACE	Stitch transferred	

- 3) Mark on memory card where hole is required, then continue in same way as for making patterns in Pattern Book 24.

CARE AND MAINTENANCE OF THE MACHINE

The machine must always be kept clean and oiled to ensure satisfactory use.

- 1) Use hand brush from the accessory box to remove dust and loose fibres.



- 2) Apply oil lightly to butts of needles.

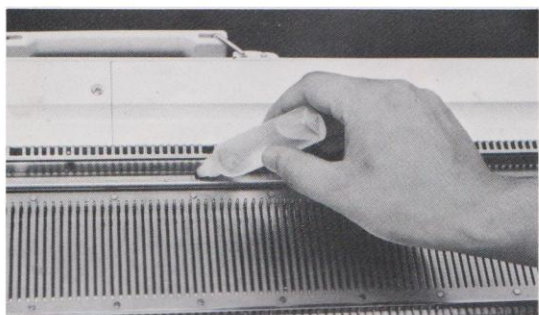

- 3) Apply oil to the underside of the carriage wipe away all dirt and apply oil to the dotted line shown in picture.

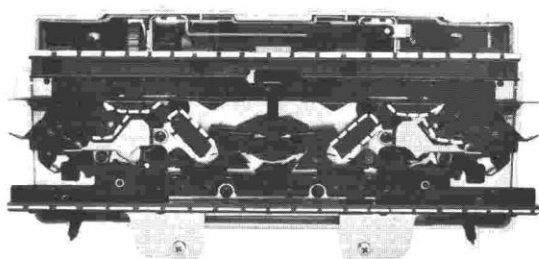

HOW TO STOW THE MACHINE AWAY

1. Take the card and the card support off of the carriage. Collapse the handle by pushing it down towards you. Unscrew arms knobs and remove fabric press.
2. Take the tension assembly and the extension rails or carriage stoppers off the main body. (To remove extension rails push up and pull outwards).
3. Place carriage on main body at right hand side of needle bed. Place carriage clamp at right on needle bed and connect it to arm knob screw. Tighten arm knobs.

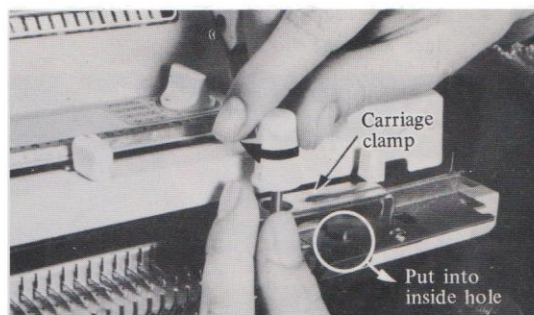

4. Loosen clamps and remove main body from table. Collapse clamps.
5. Stow the following parts away in case cover.

- 1) Tension assembly.
- 2) Card support (Beside lace carriage).

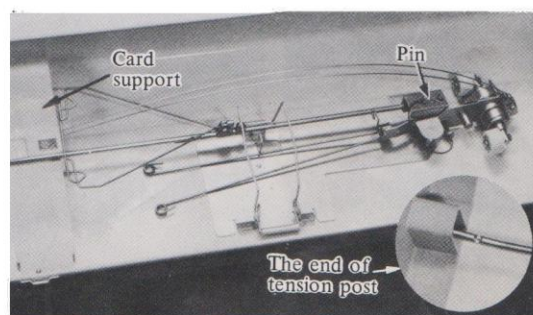

- 3) Fabric press.
Secure this with spring in lid.

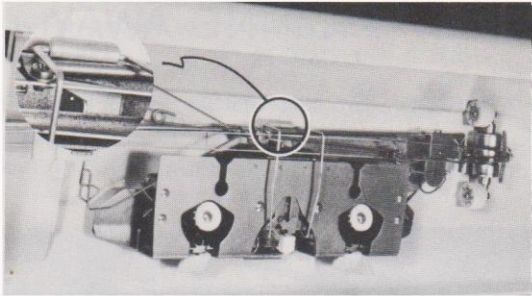

- 4) Lace carriage.
a. Place in the holder located in the case cover.
b. Press lace carriage down slightly at the same time pulling lock button.
c. Release lock button so that it clips into lace carriage holder.

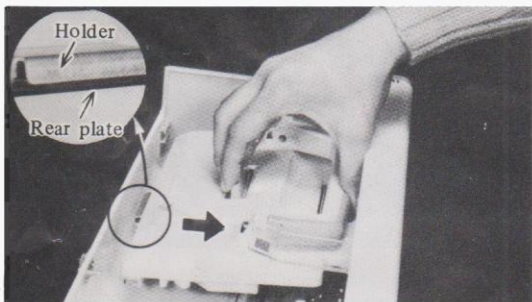

6. Set weight comb as shown in picture so that lug comes through hole. Secure this with spring clip as shown.

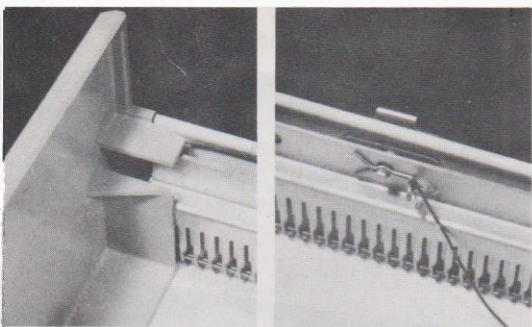

7. Replace following parts in accessory box.
a. Weight (C)
b. Oil

- c. Paraffin wax
d. Hooks (B)
f. Latch needle tool
g. Transfer tools
h. Seaming needle
i. Carriage stopper
j. Hand brush
k. Crochet hook
l. Plastic snap
m. Spare needles

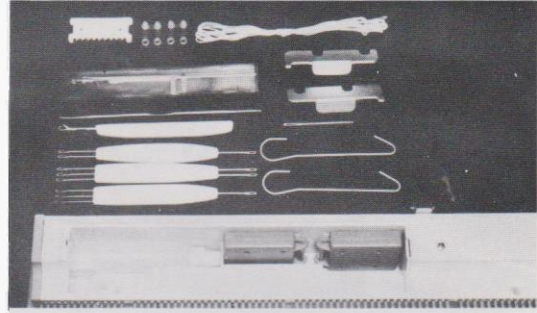

8. Holding both ends of case cover, cover machine body and fix with padlock.

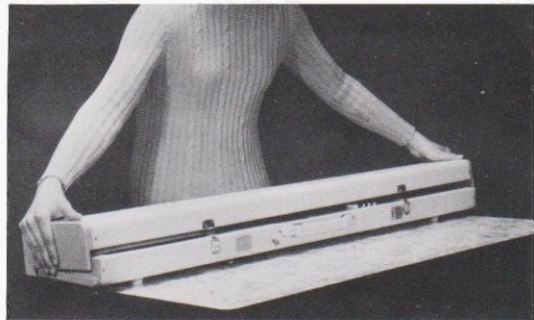

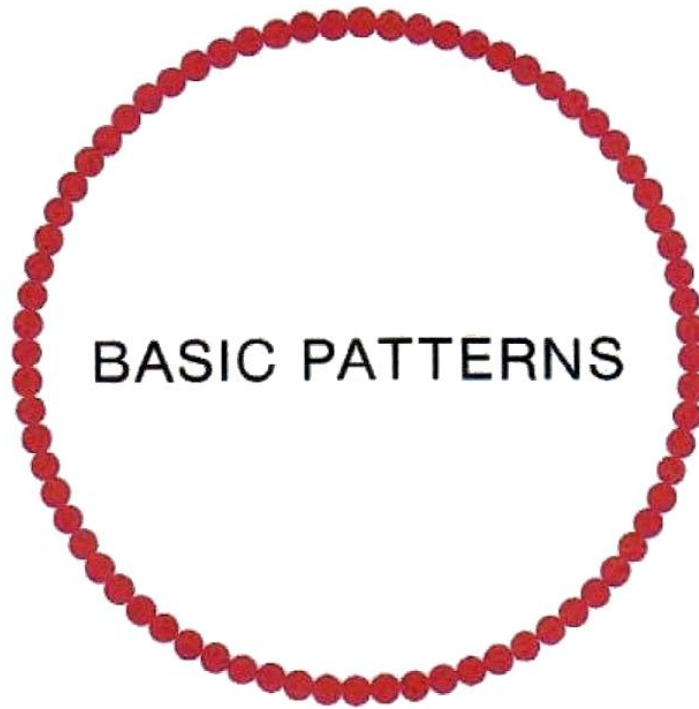

Two color patterns.....17 kinds
Slip stitch patterns 9 kinds
Tuck patterns 7 kinds
Weaving patterns..... 6 kinds
Lace patterns 3 kinds

TWO COLOR PATTERN



CARD
No 4

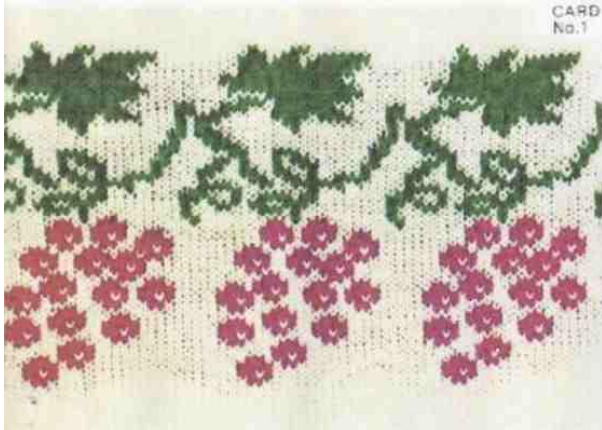

CARD
No.1



CARD
No 5

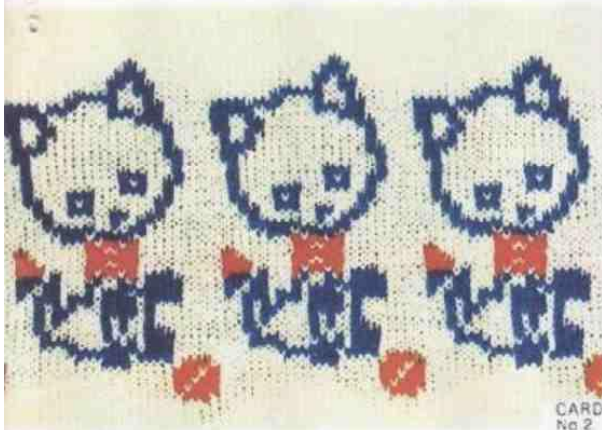

CARD
No 2

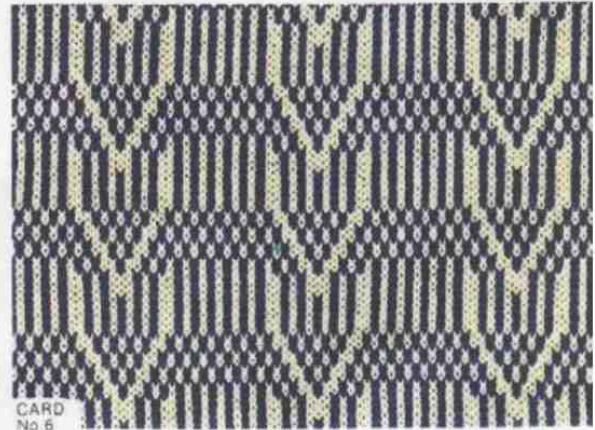

CARD
No 6

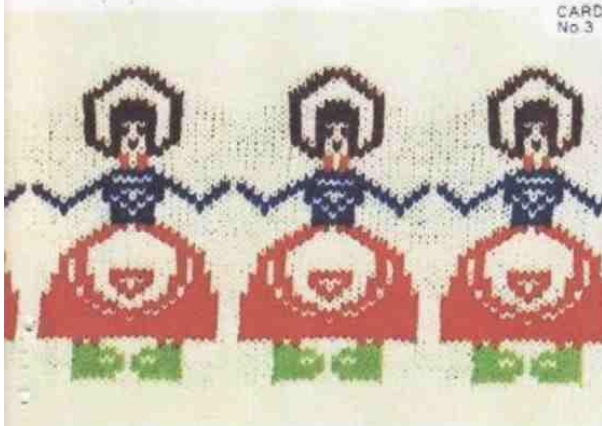

CARD
No.3



CARD
No 7

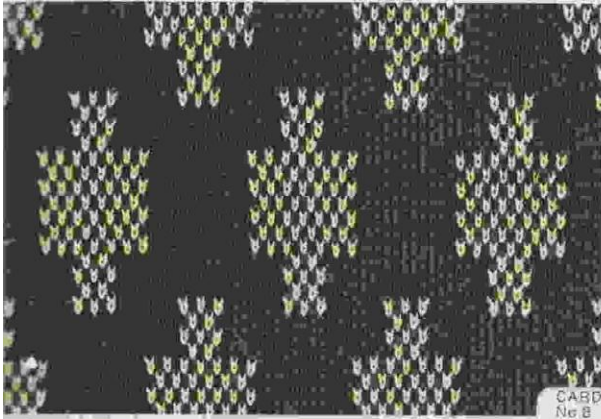

CARD
No. 8



CARD
No. 12

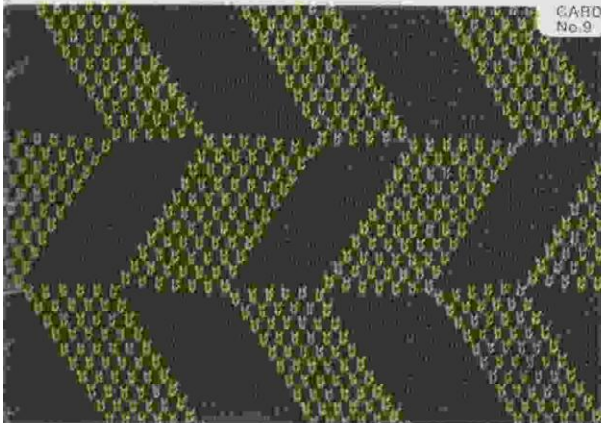

CARD
No. 9

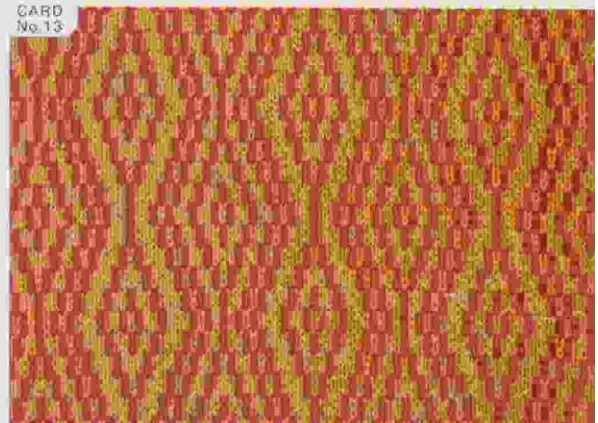

CARD
No. 13



CARD
No. 10



CARD
No. 14

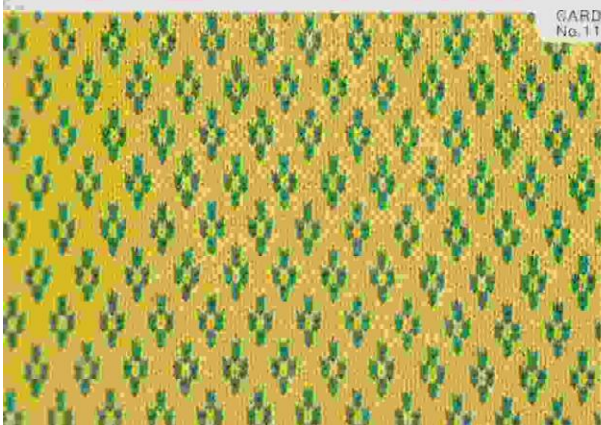

CARD
No. 11



CARD
No. 15



CARD
No.16
CARD
No.17



CARD
No.9
CARD
No.8



SLIP STITCH
PATTERN

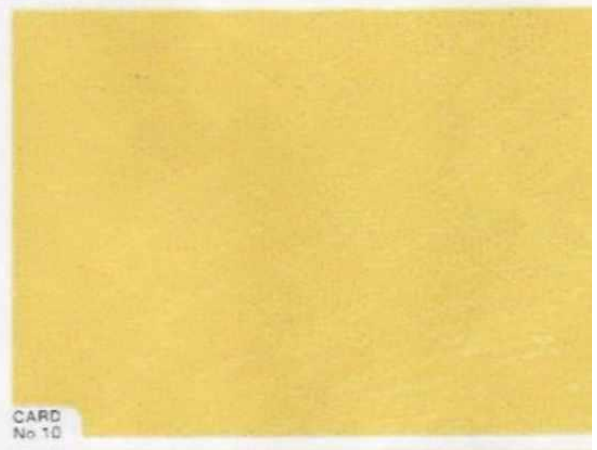

CARD
No.10
CARD
No.12



CARD
No.17

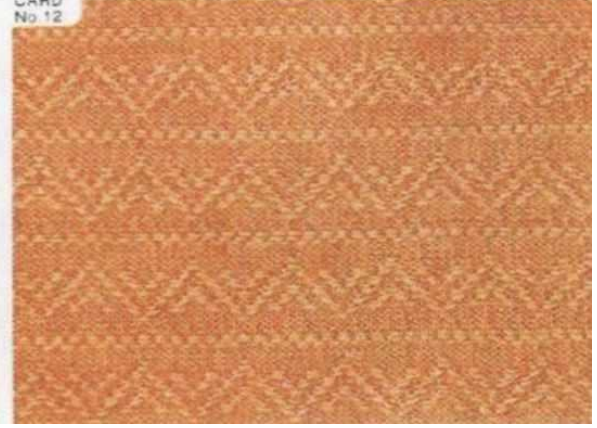

TUCK PATTERN



CARD No 5

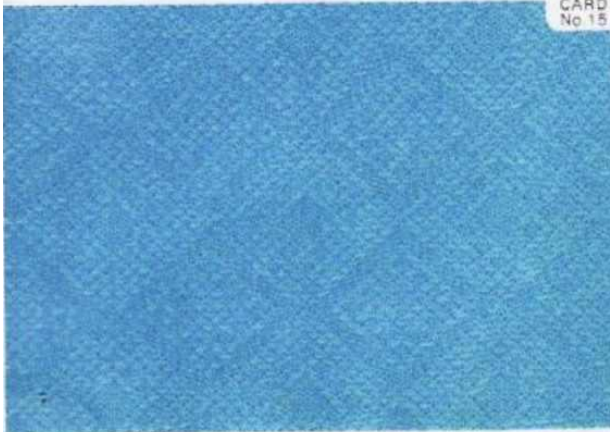

CARD No 15

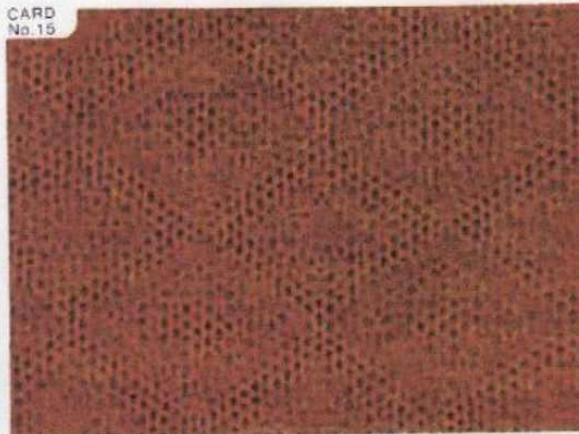

CARD No 15



CARD No 14

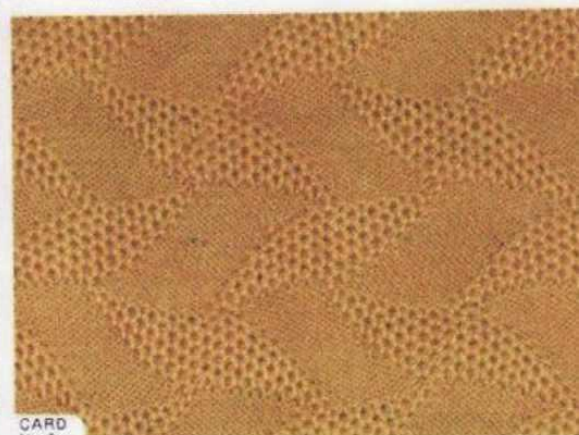

CARD No 9



CARD No 11

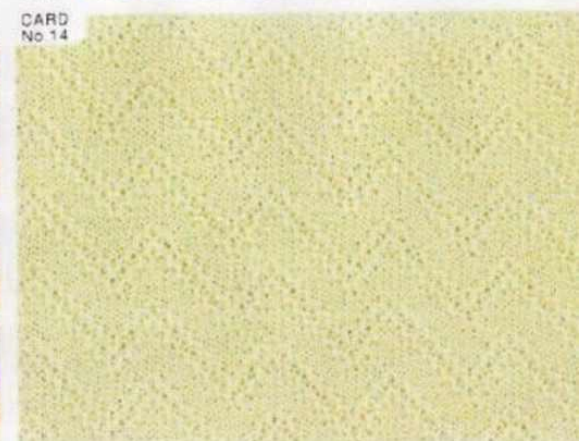

CARD No 14

WEAVING PATTERN

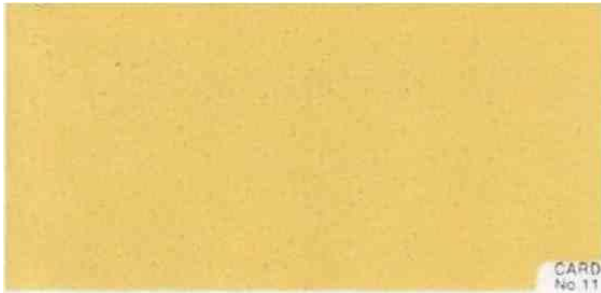

CARD
No. 11



CARD
No. 10

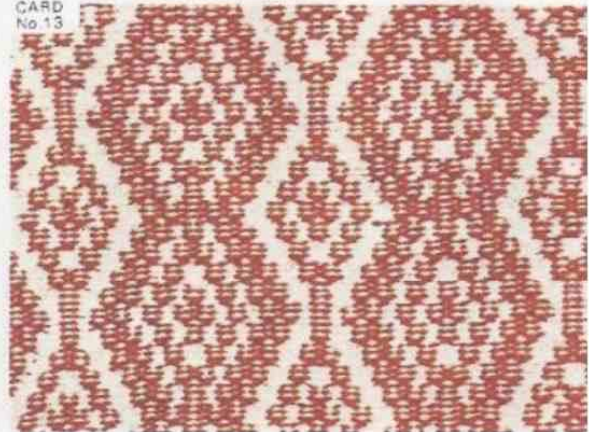

CARD
No. 13

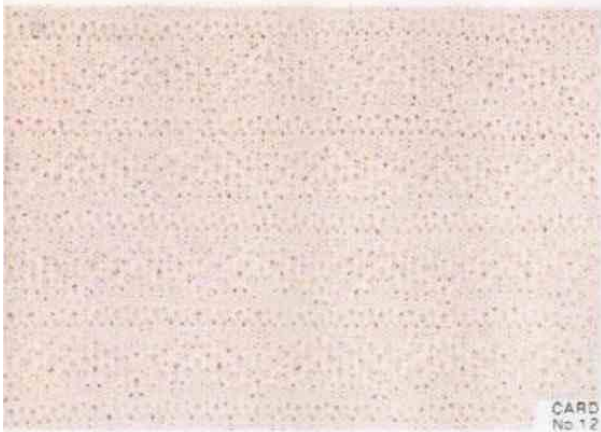

CARD
No. 12

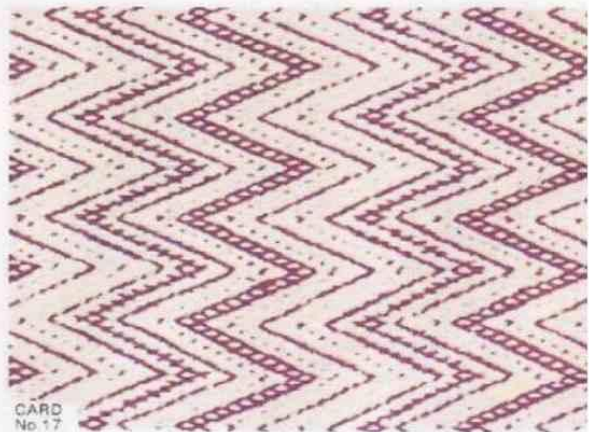

CARD
No. 17



CARD
No. 8

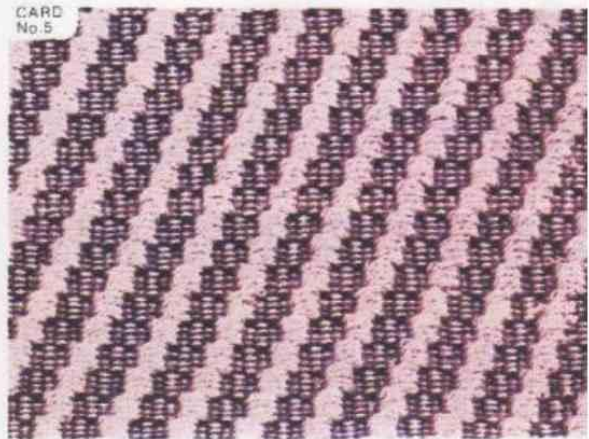

CARD
No. 5

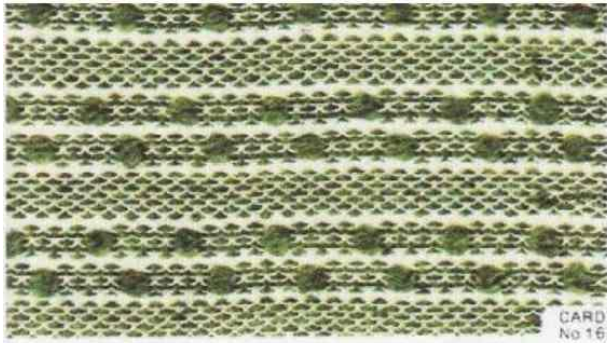

CARD
No 16



CARD
No 7

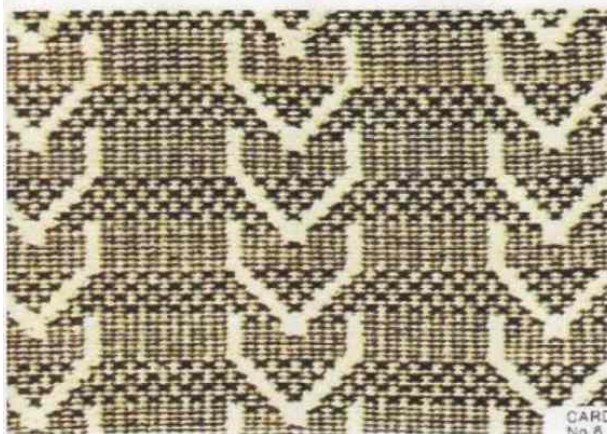

CARD
No 6

LACE PATTERN

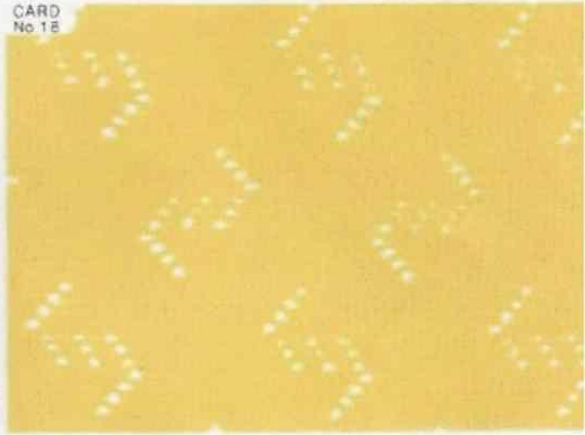

CARD
No 18

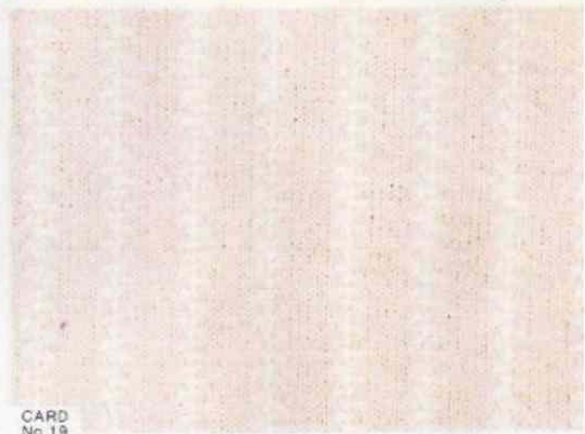

CARD
No 19



CARD
No 20

CHART OF APPLICABLE PATTERN

Pattern Card No.	Two color pattern	Slip stitch pattern	Tuck pattern	Weaving pattern	Lace pattern
1	0				
2	0				
3	0				
4	0				
5	0	0		0	
6	0			0	
7	0			0	
8	0	0	0		
9	0	0	0		
10	0	0	0		
11	0	0	0		
* 12	0	0	0		
13	0			0	
14	0	0	0		
15	0	0	0		
* 16	0			0	
17	0	0		0	
18					0
19					0
20					0

* : Please care that during the knitting there are plain knitting some times.

THE SINGER COMPANY (U.K.) LIMITED

CONSUMER PRODUCTS DIVISION, 255 HIGH STREET, GUILDFORD, SURREY.

*A trade mark of THE SINGER COMPANY.

5000576N
Printed in Japan