



CHUNKY KNITTER
INSTRUCTION BOOK
MOD.150

Congratulations on your purchase of this Chunky Knitter.

This machine has been designed to knit wide variety of bulky yarns for making fashionable garment with great ease of operation.

Various stitch samples are presented in this book, but by adding a touch of creativity fancy stitch patterns are discretion of you.

Read this in-depth instruction book, and enjoy knitting.

CONTENTS

	Page
MACHINE AND ACCESSORIES.....	1
SETTING UP THE MACHINE.....	3
NEEDLE BED AND CARRIAGE.....	5
YARN PREPARATION.....	8
THREADING THE YARN.....	9
YARN AND STITCH DIAL.....	10
CAST-ON AND KNITTING.....	11
PATTERN KNITTING.....	18
Tuck Stitch.....	19
Tuck Stitch in colours.....	22
Slip Stitch.....	24
Slip Stitch in colours.....	25
Knit-in (Fair Isle).....	27
Intarsia Pattern.....	29
Plating.....	32
TAKING A TENSION GAUGE.....	33
HOW TO ATTACH KNIT CONTOUR ATTACHMENT.....	36
HOW TO KNIT A GARMENT.....	37
KNITTING TECHNIQUES.....	
Fully fashioned decrease.....	42
Fully fashioned increase.....	42
Partial knitting by decreasing stitches.....	43
Partial knitting by increasing stitches.....	44
K1, P1, Rib.....	45
Picot Hem.....	48
Holding stitches.....	50
Put the yarn mark.....	52
Buttonhole.....	53
Openwork.....	53
Cable Pattern.....	54
Garter Stitch.....	54
Joining on the machine.....	55
Blind Stitch.....	58
Grafting.....	58
Slip Stitch.....	59
Sew in Yarn Ends.....	59
Cord knitting.....	60
Braid.....	60
HELPFUL HINTS.....	
To replace a dropped stitch.....	61
If a dropped stitch has run down for several rows.....	62
To unravel knitted fabric on the machine.....	63
If the Carriage has jammed.....	64
To replace a damaged needle.....	64
MAINTENANCE.....	66
REPACKING THE KNITTER.....	66

MACHINE AND ACCESSORIES

Machine

Place the Knitter on a table with the Carrying Handle away from you.

Unfasten the Latches "A".

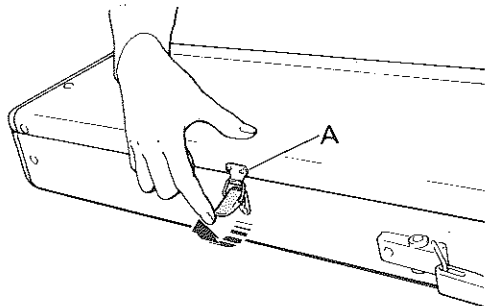

Lift the Top Cover "B" slightly, pull it towards you and remove it from the knitter.

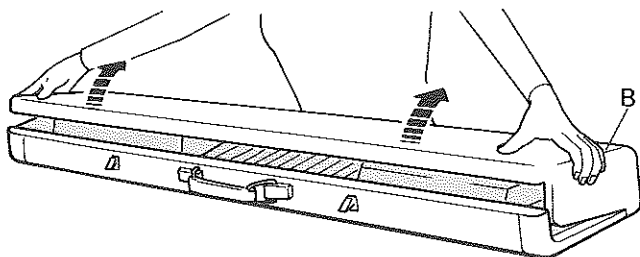

Place the Top Cover as shown below.

Release the wire spring "C" from holding bracket "D" located inside the Top Cover.

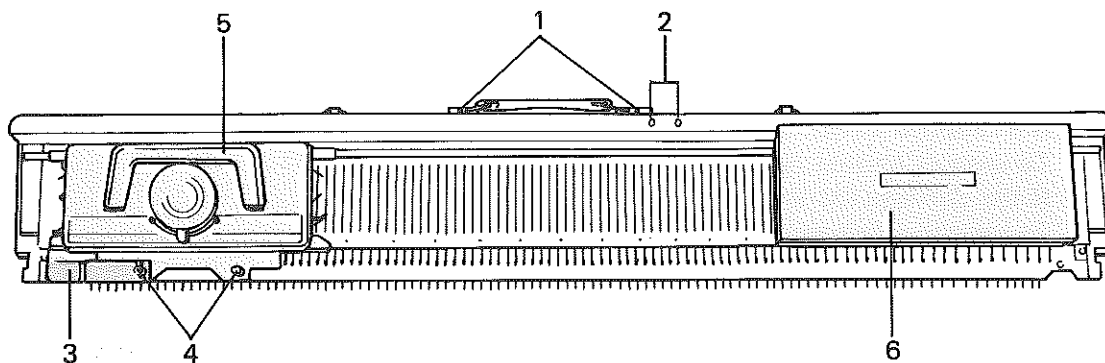
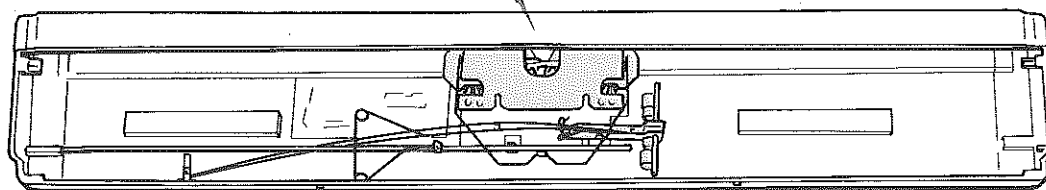
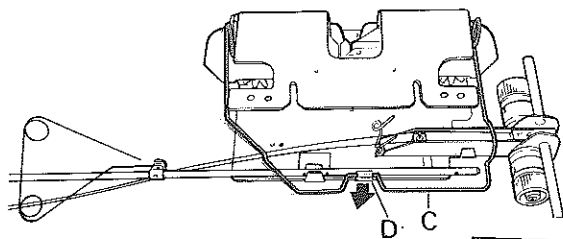

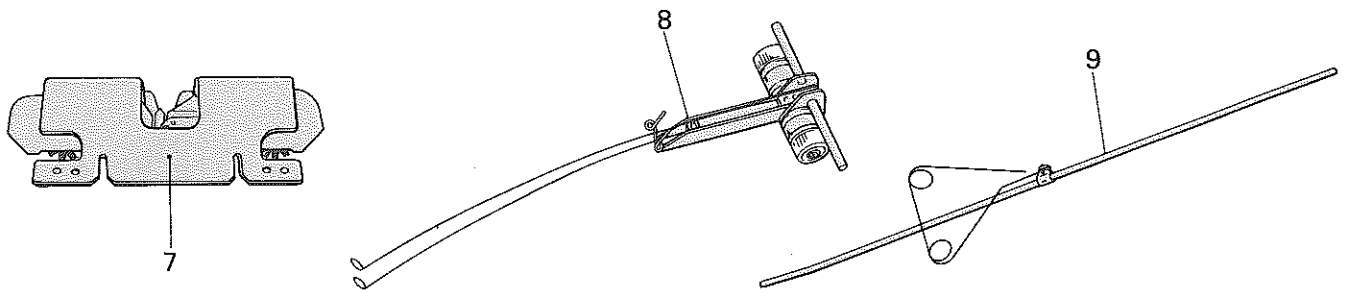

1. Bracket Socket
2. Row Counter Securing Studs
3. Carriage Fastener

4. Arm Nuts
5. Carriage Handle
6. Accessory Box

7. Arm
8. Auto Tension
9. Yarn Rod

Accessories

Take out the Accessory Box, and open it to find the following accessories are packed.

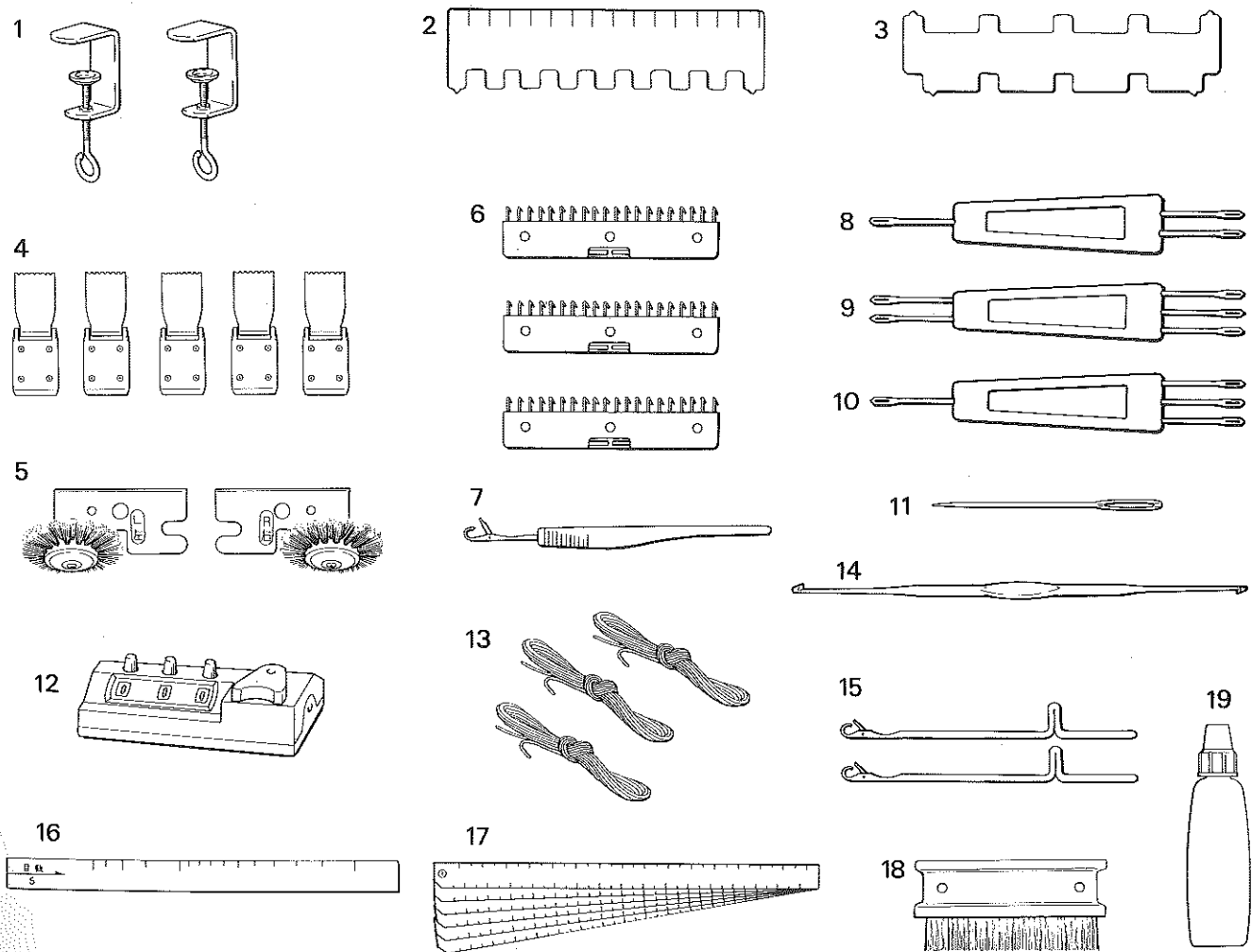

1. Clamp (2)
2. Needle Pusher (1/1-0)
3. Needle Pusher (1/3-3/1)
4. Claw Weight (5)
5. Tuck Brush (left & right)
6. Comb Weight (3)
7. Tappet Tool

8. Transfer Tool (1 x 2)
9. Transfer Tool (2 x 3)
10. Transfer Tool (1 x 3)
11. Tapestry Needle
12. Row Counter
13. Ravel Cord (3)
14. Crochet Hook

15. Spare Needle (2)
16. Gauge Scale
17. Stitch Scale (6)
18. Cleaning Brush
19. Oil

SETTING UP THE MACHINE

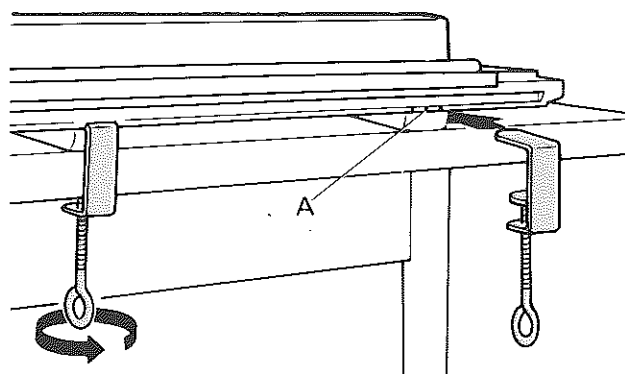

Insert the Clamps into the slots "A" at the bottom of Needle Bed.

Fasten the Clamps by turning screws in the arrowed direction.

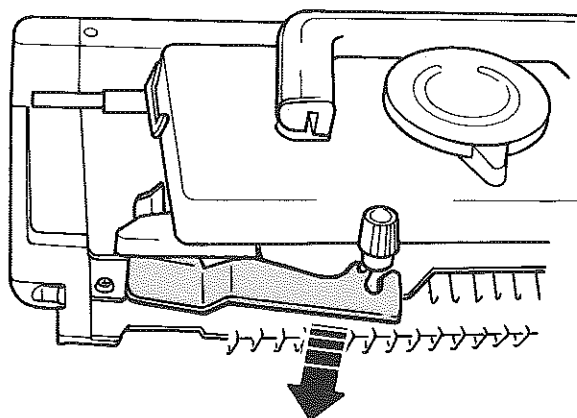

Loosen both Arm Nuts by turning them in the arrowed direction.

Remove the Carriage Fastener.

Do not lose the Carriage Fastener as this is used for securing the Carriage to the Needle Bed while the Knitter is not in use.

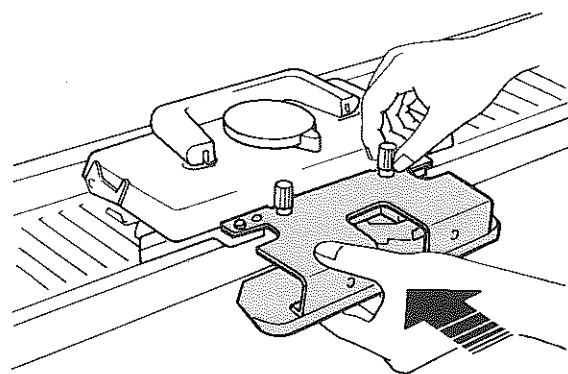

Remove the Arm from the Top Cover and insert it under the two Arm Nut screws.

Push the Arm as far as it goes and tighten the Arm Nuts firmly by turning them in the arrowed direction.

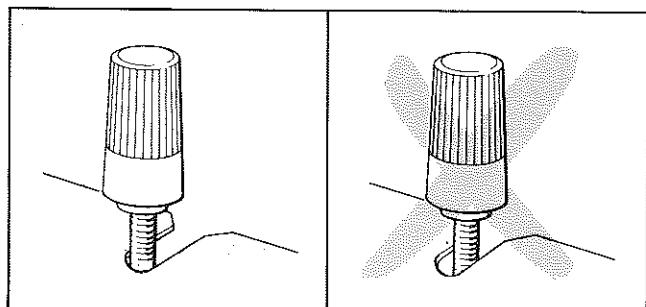

Ensure that the Arm Nuts fit correctly into the cut-out of the Arm.

Raise the Carriage Handle.

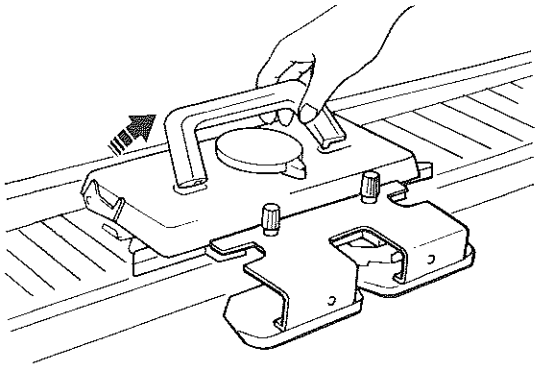

Attach the Row Counter by fitting the slots of the Counter "B" to the Studs "C" on top of the machine.

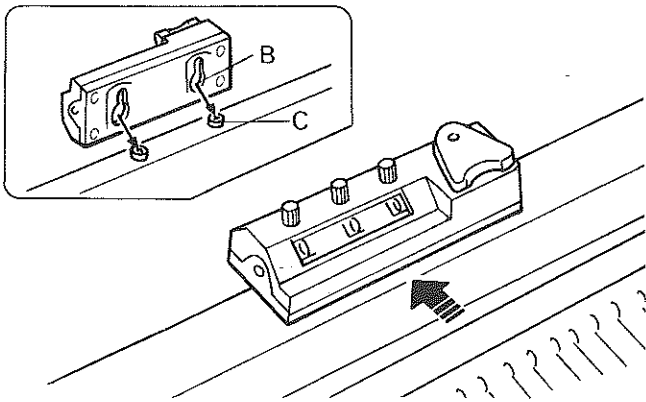

Remove the Auto Tension and Yarn Rod from the inside of the Top Cover.

Insert the short bent end of the Yarn Rod "D" into the right side of Handle Bracket Socket.

Turn the Tension Spring "E" until they snap into position.

Fit the Auto Tension on top of the Yarn Rod.

Raise the Tension Guide "F".

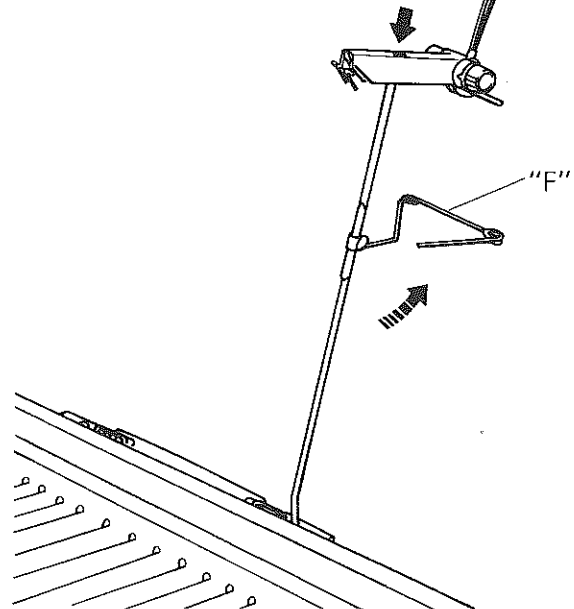
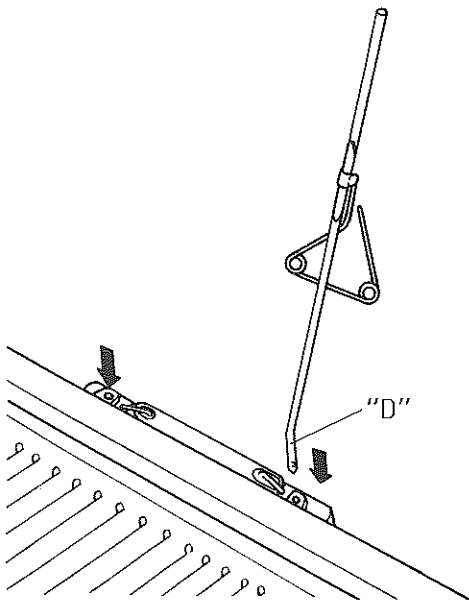
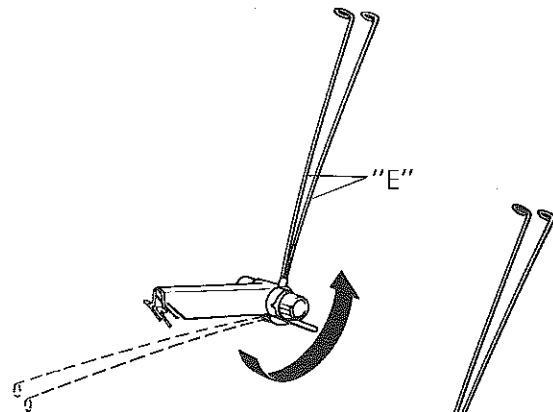

NEEDLE BED AND CARRIAGE

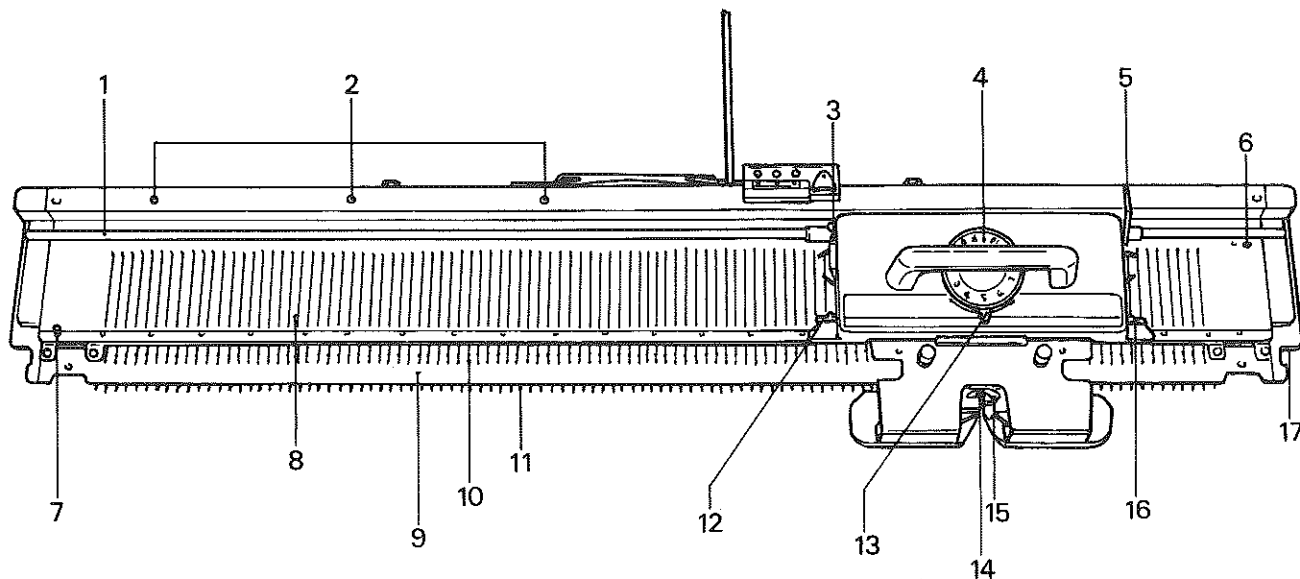

- | | | |
|--|-------------------------|--------------------------|
| 1. Rail | 6. Carriage Stopper Pin | 12. Russel Lever (left) |
| 2. Knit Contour (Option)
Securing Studs | 7. Carriage Stopper Pin | 13. Cam Lever |
| 3. KC Lever | 8. Needle Bed | 14. Main Yarn Feeder |
| 4. Stitch Dial | 9. Vinyl Tape | 15. Plating Yarn Feeder |
| 5. RC Lever | 10. Latch Needle | 16. Russel Lever (right) |
| | 11. Sinker Post | 17. Yarn Holder |

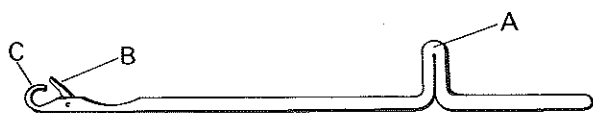

Latch Needle

- A - butt
- B - latch
- C - hook

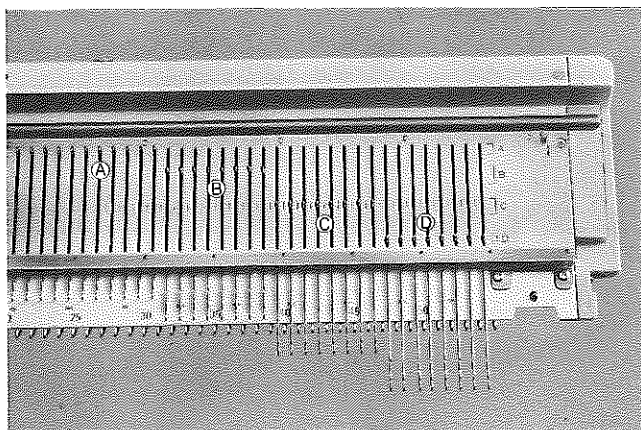

Needle positions

On both left and right ends of the Needle Bed, the letters A, B, C and D associated with brackets "J" are engraved.

To operate the needles, align their butts within the brackets.

- A - Needles do not knit.
- B - Needles knit stockinet and stitch pattern.
- C - Needles knit stockinet only.
- D - Needles do not knit when Russel Levers are set at —. Needles are knitted back to B position when Russel Levers are set at =.

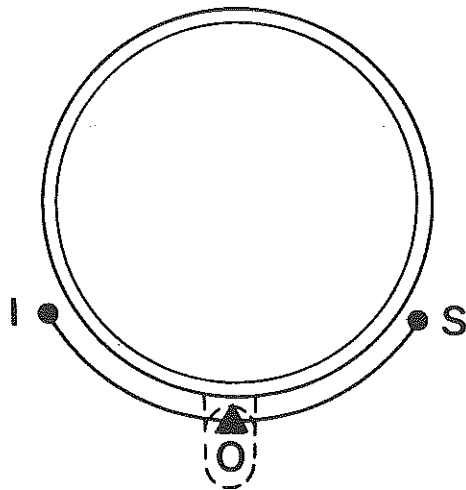

Cam Lever

Operated to select a stitch type.

Setting positions

Three setting positions are marked as shown opposite, and each position is selected by setting the knob of the Cam Lever on selected mark.

O – STOCKINET, PLATING, TUCK STITCH

S – SLIP STITCH, KNIT-IN (FAIR ISLE)

I – INTARSIA PATTERN

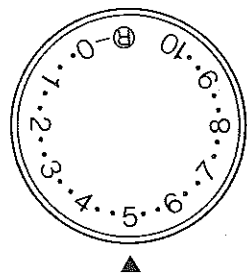

Stitch Dial

Operated to regulate the size of stitches by setting its number to the ▲ mark at the front of the Stitch Dial.

If the same type of yarn is used, the higher the number of Stitch Dial is selected, the larger the stitch size is knitted (the fabric is loose), and the lower the number, the smaller the stitch size (the fabric is tight).

Ⓡ is selected when the Ribber SR-150 is attached.

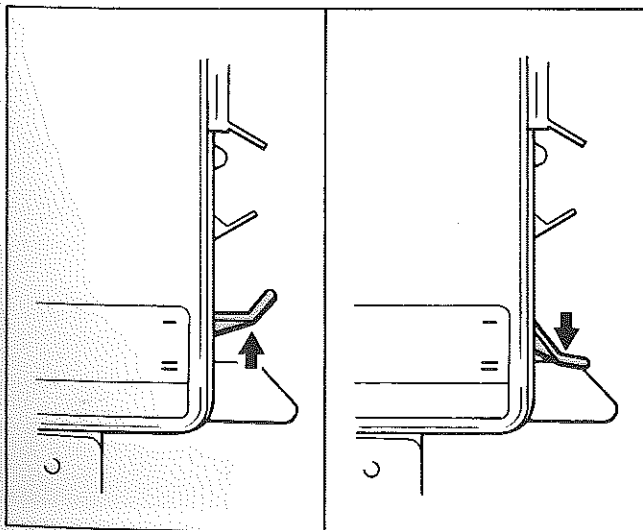
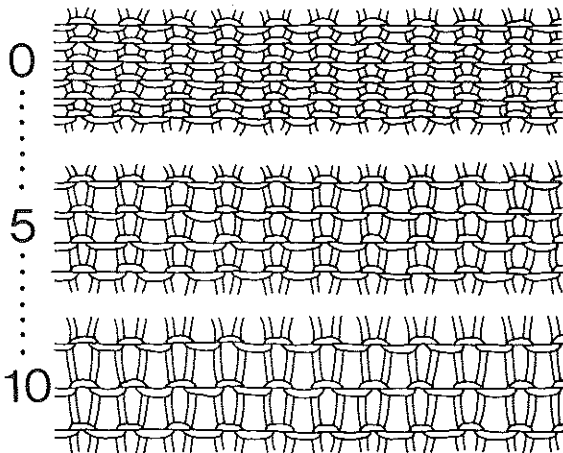

Russel Levers

Control needles in D position.

— — Do not knit the needles in D position.

≡ — Knit the needles in D position.

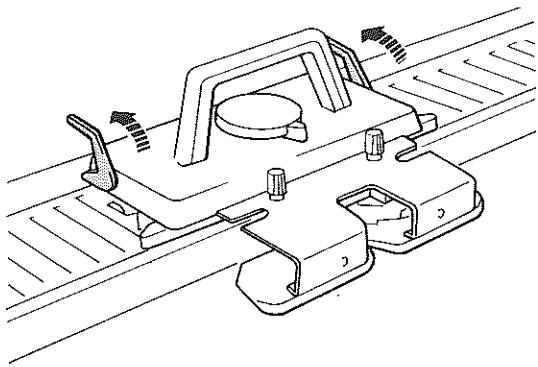

Feeding Levers

The feeding lever at the right side of the Carriage is designated as **RC Lever** and activates the Row Counter, and the Knit Contour Attachment (option) if it is in use.

The feeding lever at the left side of the Carriage is designated as **KR Lever** and feeds the Pattern Paper if the Knit Contour Attachment (option) is in use.

(Note: When the Knit Contour is in use, raise either of the RC Lever or KC Lever, or both of them depending of the tension gauge, refer to page 36.)

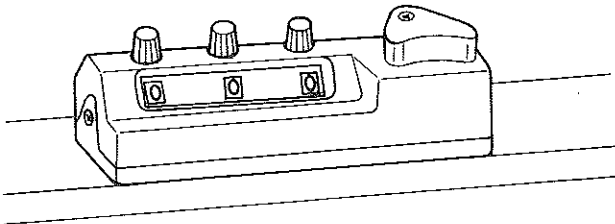

To operate the Row Counter

Raise the RC Lever at the right side of the Carriage.

To stop the Row Counter, lay down the RC Lever.

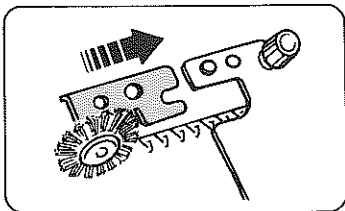

Tuck Brush

Attach the right Tuck Brush at the right side of the Arm and the left Tuck Brush at the left side of the Arm as shown.

Depending on the type of yarn, if the stitches tend to become loose on the needles, it is advised to attach the Tuck Brushes for knitting other than the tuck stitches, but never in Intarsia Patterns.

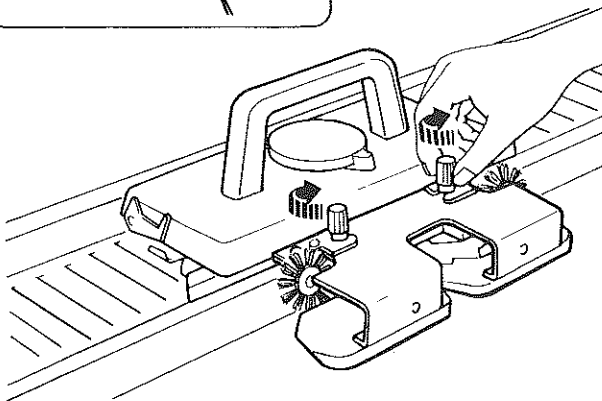

To remove the Carriage from the needle bed.

(with Arm on)

Move the Carriage to the either end of the needle bed, and push it off while lifting the front of the Carriage Arm to clear the Stopper Pin.

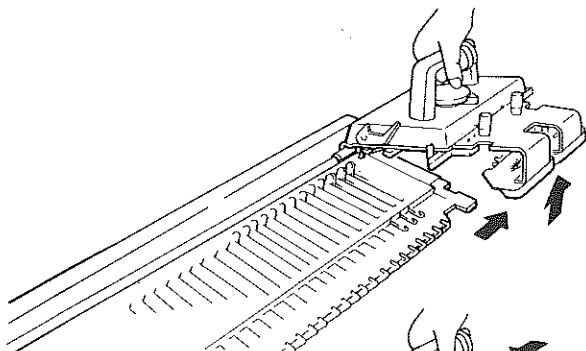

To set the Carriage on the needle bed.

(with Arm on)

Fit the Carriage pipe to the needle bed rail, and push in while holding the front of the Arm to clear the Stopper Pin.

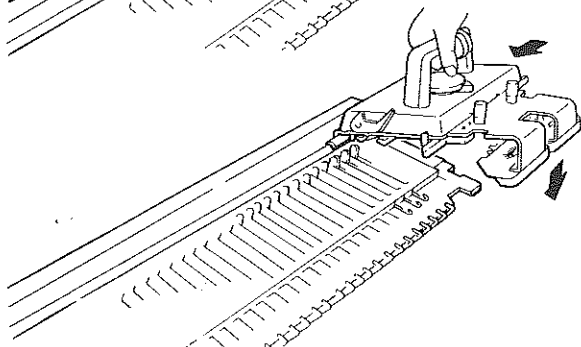

YARN PREPARATION

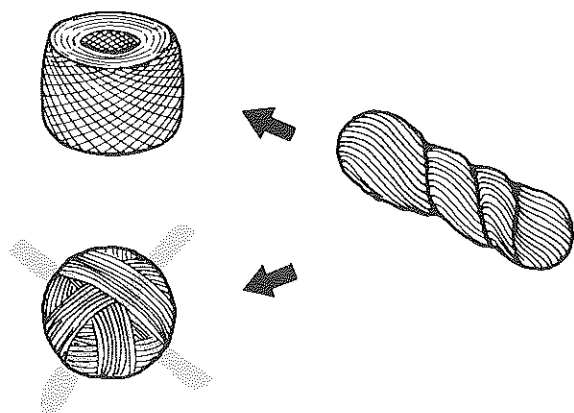

Your machine is designed to knit wide variety of bulky yarns, but it is recommended to use extra thick yarn for the first practice of knitting. (see page 10)

Correct preparation of yarns before you start knitting is very important. This extra care will make knitting more enjoyable, easier and the quality of your garment much better.

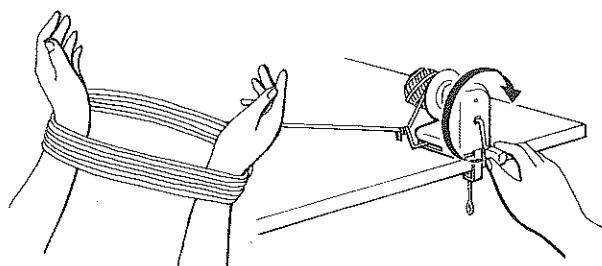

It is impossible to knit from a hank of yarn or hand wound ball.

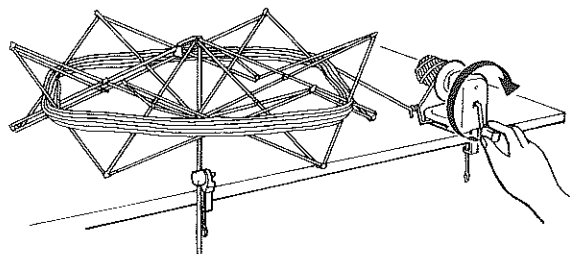

You must open the hank of yarn and replace it on your arms (or on an optional Skein Holder) to wind it into a ball, suitable for machine knitting.

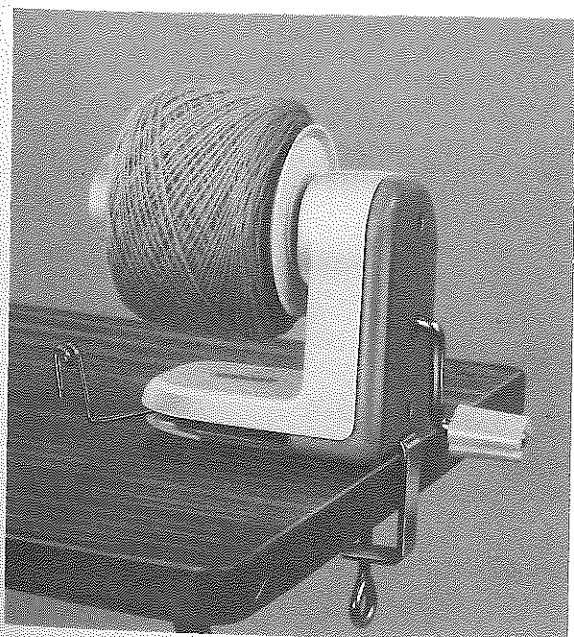

For winding yarn, use of an optional Yarn Ball Winder is recommended.

When yarn is rewound, ensure that the yarn end comes out freely without lifting the ball.

If the yarn ball has been wound too tight for the yarn to come out freely, unwind the ball into a basket orderly.

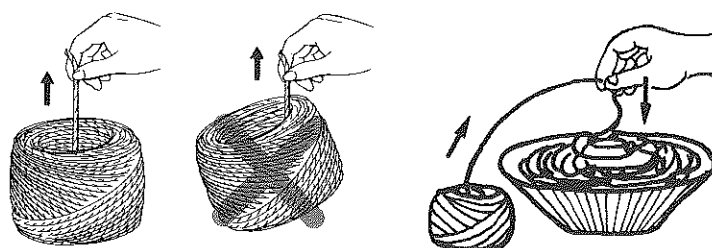

THREADING THE YARN

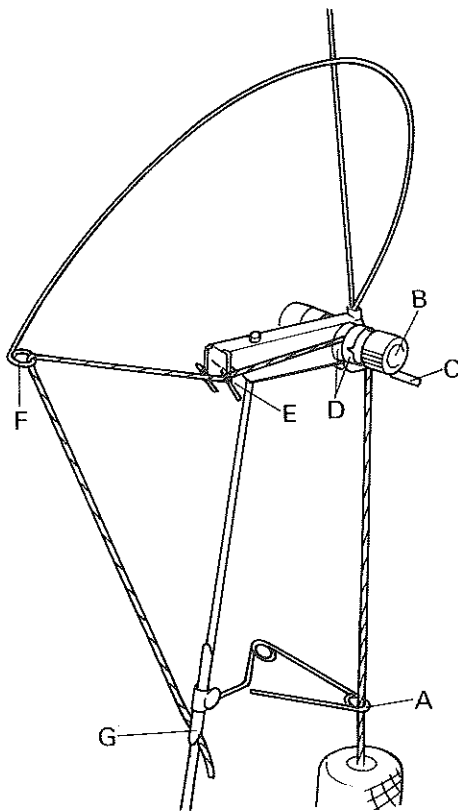

For Practice, prepare extra thick yarn.

Thread the right side of Auto Tension as follows:—

- ① through right Tension guide eyelet "A",
- ② between Tension Dial "B" and Guide Bar "C",
- ③ between two Tension Discs "D",
- ④ through right Yarn Guide eyelet "E",
- ⑤ through right Tension Spring eyelet "F".

Pull the yarn end and hook it in the Yarn Clip "G".

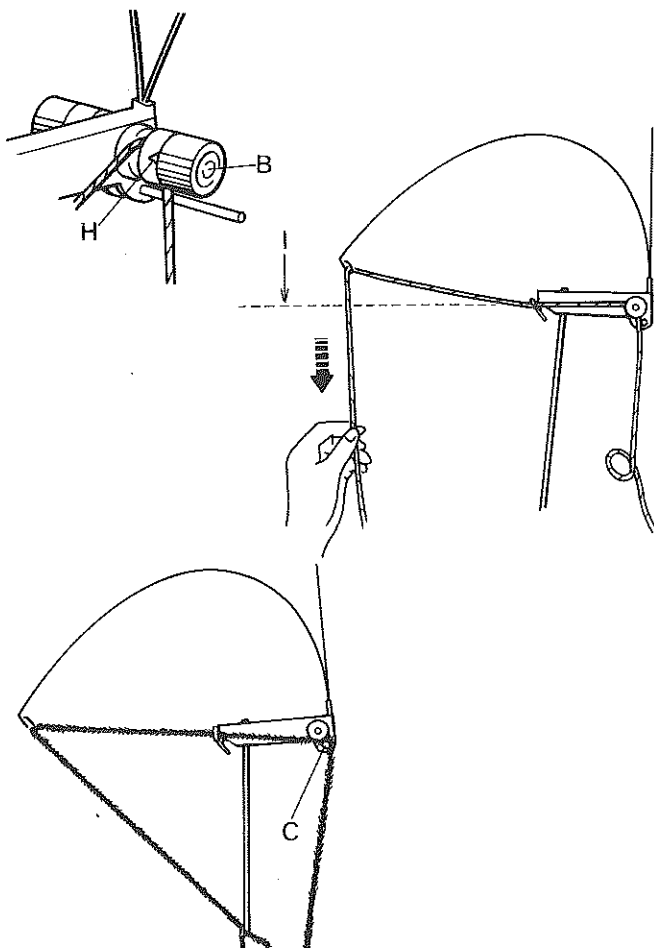

Adjusting Tension Dial

Adjust the Tension Dial according to type of yarn by turning the Tension Dial "B" until a required number corresponds to the < shape cut-out "H" checking following points.

1. Yarn comes out freely from the yarn ball.
2. Distance between the Tension Spring and the horizontal line "I" — 10–20cm. must be maintained.

If you use heavy weight slub yarn, place it on the Guide Bar "C" only.

It is advisable to pull out a certain length of the yarn from the yarn ball before casting on.

YARN AND STITCH DIAL

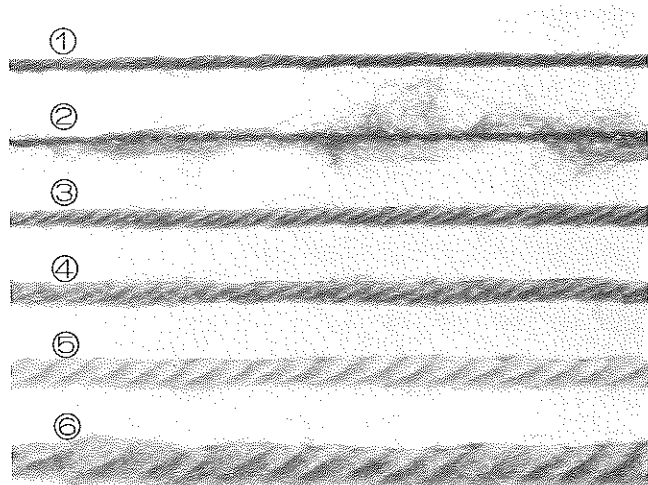

To obtain suitable stitch size, or suitable tension for a garment, set the Stitch Dial Number according to the thickness of the yarn, referring to the photograph of yarns in actual size and the table opposite.

TYPE OF YARN	STITCH DIAL
① Medium thick	1 – 2
② Mohair	3 – 4
③ Very thick	5 – 6
④ Extra thick	6 – 8
⑤ Super extra thick	8 – 10
⑥ Super extra thick (every second needle)	6 – 7

The thicker the yarn, the higher the Stitch Dial Number must be selected, and the thinner the yarn, the lower the Stitch Dial Number.

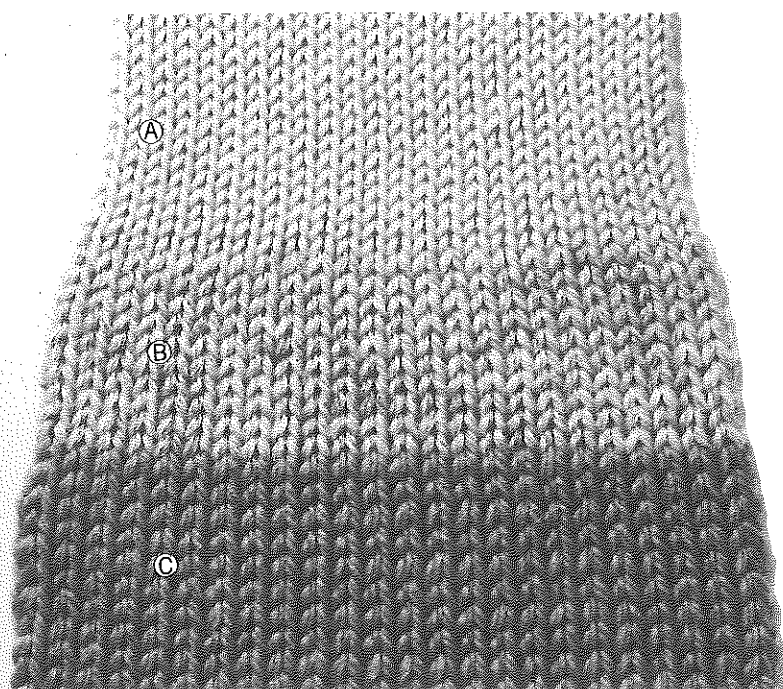

A – Stitch Dial at 1 with medium thick yarn.

B – Stitch Dial at 5 with very thick yarn.

C – Stitch Dial at 9 with super extra thick yarn.

CAST-ON AND KNITTING

Cast-on (1)

1. Push up the required number of needles from A position to D position.

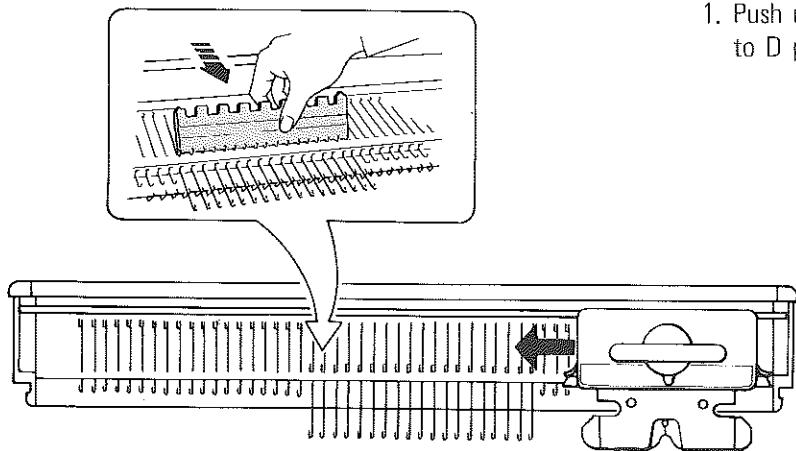

2. Set the Carriage as follows:—

Cam Lever 0
 Russel Levers = (both)

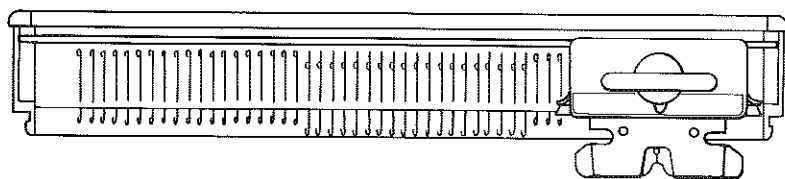

3. Slowly move the Carriage across the Needle Bed until it has passed all the needles in D position. The needles align in B position. Slide back the Carriage to the right side of the needle bed.

4. Set the Stitch Dial referring to the table on page 10.

5. Remove the yarn end from the Yarn Clip and slip it into the Yarn Feeder.

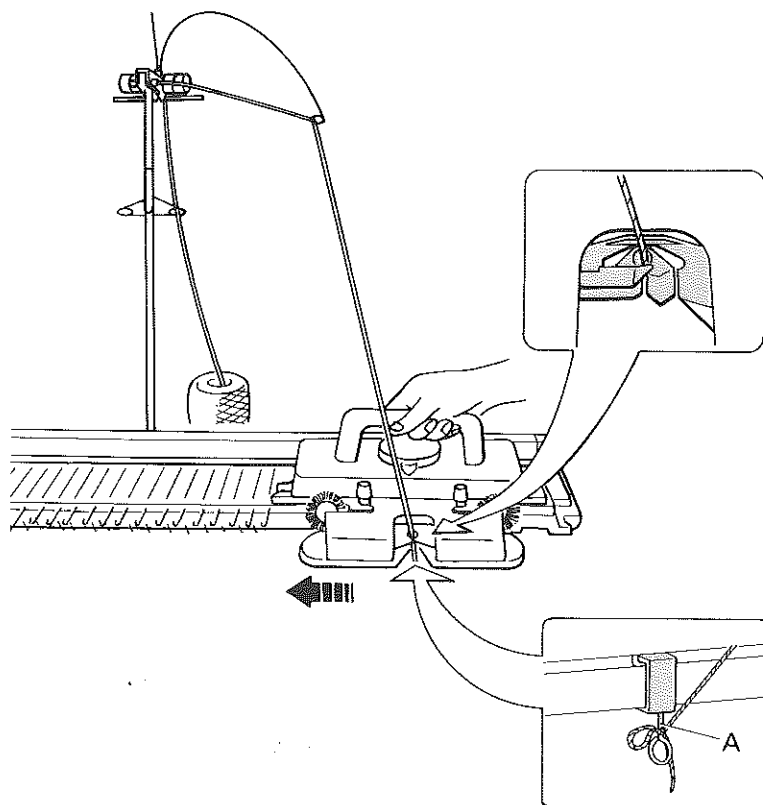

6. Tie the yarn end to the Clamp Screw Grip "A", slowly move the Carriage from right to left until it has passed all the needles in B position. Be sure to pass the Carriage over the last knitting needle by about 2–3cm.

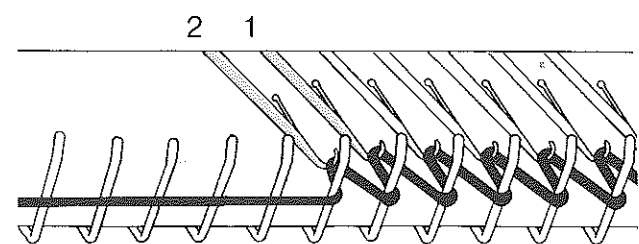

4. The yarn is hooked on the needles and sinker Post alternately.

Toward the end of the course, the needles are apt to be pulled forward by the yarn.

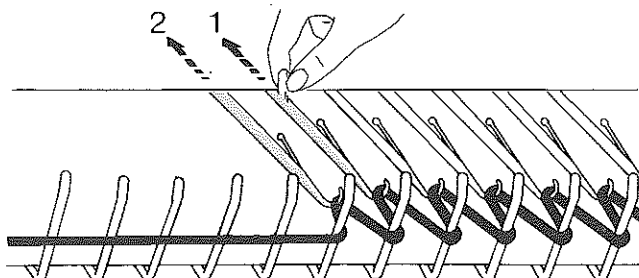

If the needles have been pulled up by the yarn, pull the yarn down from the Yarn Feeder and push back the needles by hand as shown.

(Hint) Toward the end of the first course, pull down the yarn above the Yarn Feeder by hand, the tension on the yarn is reduced and the needles will not be pulled forward.

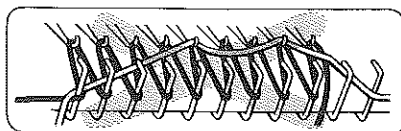
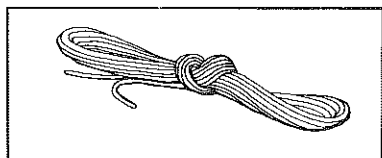

5. Take up the Ravel Cord from the Accessory Box, and untie a bundle of the cord. Make sure that there is no knot on the cord.

Hold an end of the Ravel Cord "B" in the clip "C" at the right end of the needle bed as shown.

Lay the Ravel Cord across the yarn loops between needle hooks "D" and sinker posts "E". Pull the Ravel Cord with the left hand.

Ensure that the Ravel Cord lies correctly across the loops and will not entangle with needles hooks.

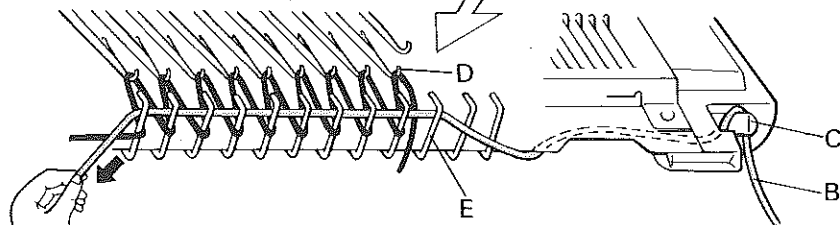

6. While pulling down the other end of the Ravel Cord, move the Carriage to the right side.

Then continue to knit 5 – 6 rows.

7. Release the end of the Ravel Cord from the clip and pull it out toward the other end.

Cast-on has been finished.

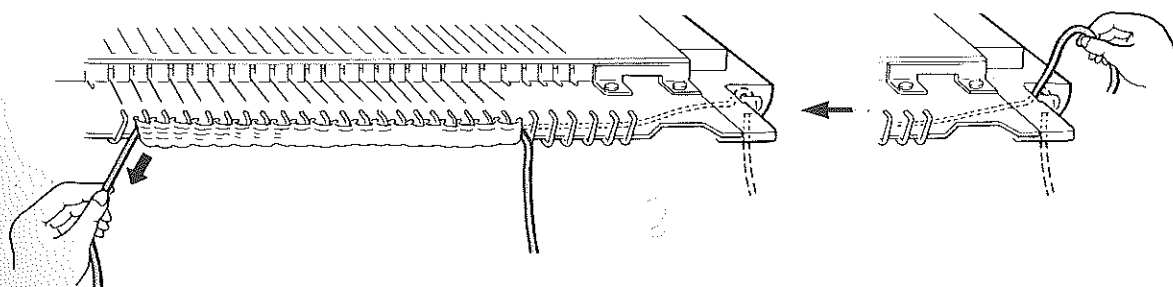
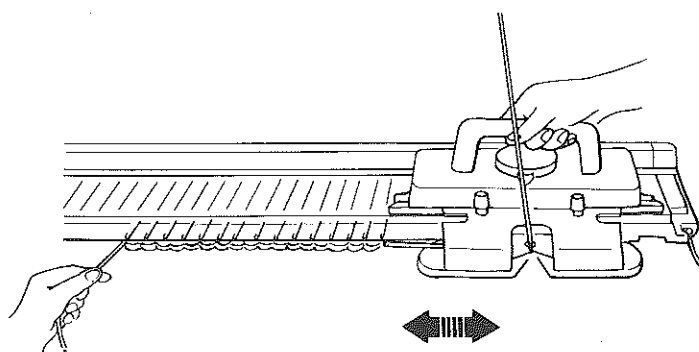

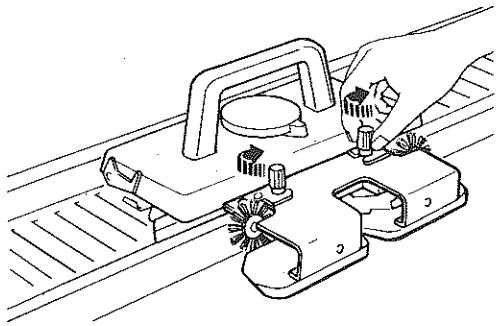

Cast-on (2)

1. Attach the Tuck Brushes referring to page 7.

2. Align required number of needles in B position.

3. Push up every 2nd needles in B position to D position using Needle Pusher (1/1-0).

4. Set the Carriage as follows:—
 Cam Lever..... S
 Russel Levers..... =

5. Set the Stitch Dial referring to page 10.

Remove the yarn from the Yarn Clip and slip it into the Main Yarn Feeder.

Tie the yarn end to the Clamp Screw Grip "A".

Slowly move the Carriage and knit 1 row.

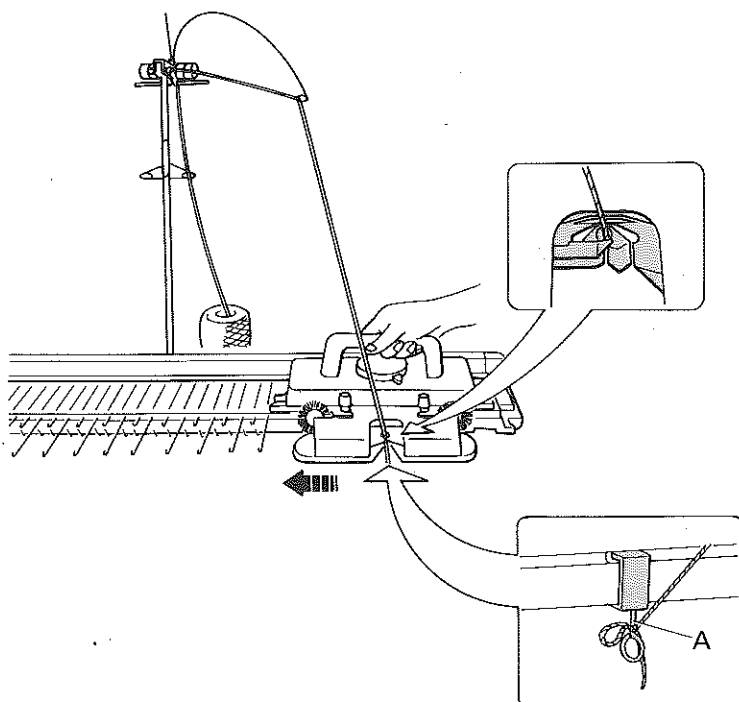
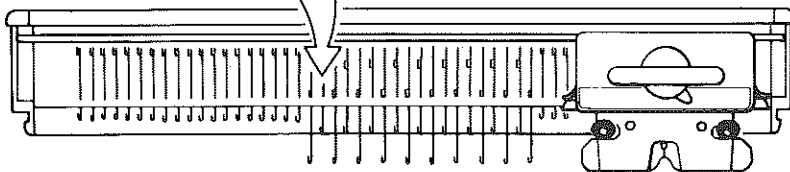
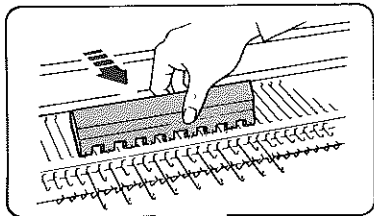
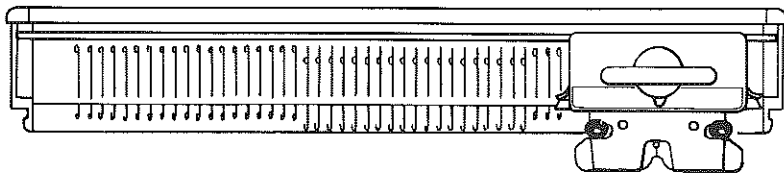

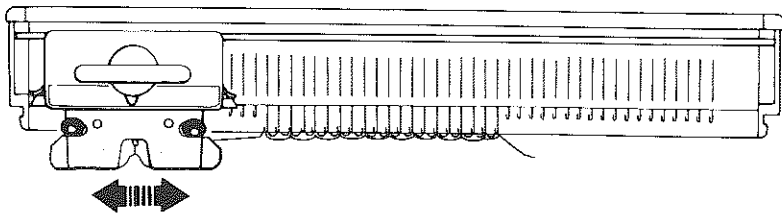

6. Be sure to pass the Carriage over the end knitting needle by about 2–3cm.

Set the Cam Lever to "0" and Continue to knit 2 – 3 rows.

The Cast-on was completed.

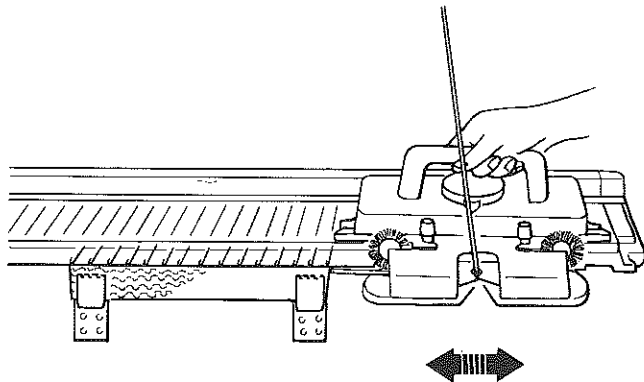

Stockinet

To continue knitting in stockinet after the cast-on, set the Carriage as follows:–

- Cam Lever 0
- Russel Levers = (both)
- Stitch Dial..... refer to page 10

Hook the Claw Weights on the fabric, near both side edges.

Attach the Tuck Brushes at both sides of the Arm.

Set the main yarn into Main Yarn Feeder.

Be sure to pass the Carriage over the last knitting needle by about 2–3cm. and the Carriage must be moved at an even speed.

Rehang the Claw Weights every 15 – 20 rows of knitting.

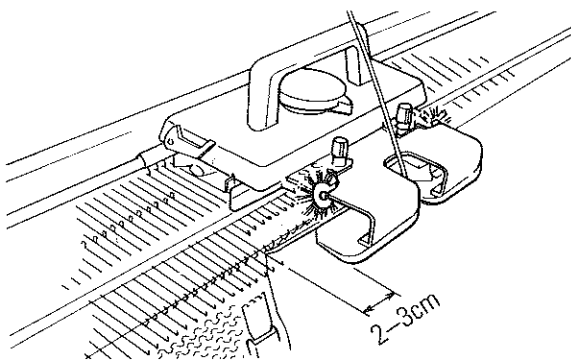

When you knit a garment

- ① Cast-on with a contrast waste yarn and knit 5 – 6 rows.
- ② Knit 1 row with Ravel Cord.
- ③ Knit the garment with main yarn.

After the garment is finished, pull out the Ravel Cord.

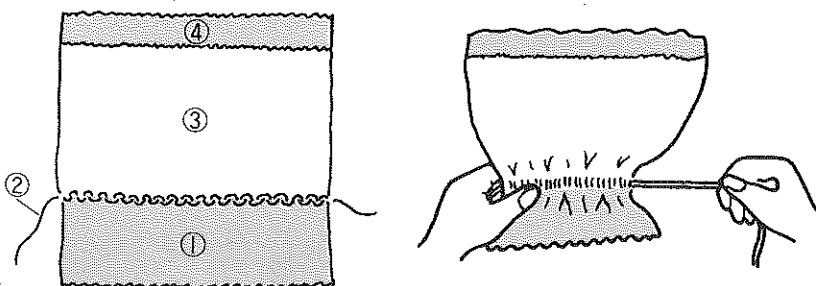

- ④ After the main knitting has been finished, exchange the yarn for the contrast waste yarn and knit 5 – 6 rows.

Take out the yarn from the Yarn Feeder and move the Carriage across the fabric, the fabric will be released from the needles.

To knit the Ravel Cord, set it in the Main Yarn Feeder, and hold the cord lightly between the thumb and forefinger.

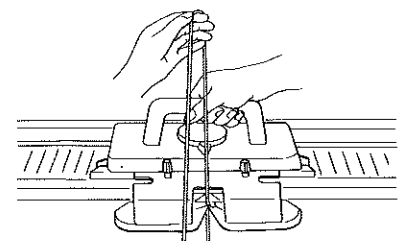

Move the Carriage very slowly.

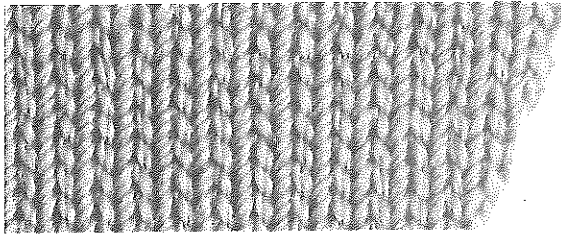

INCREASING 1 STITCH

You can only increase 1 stitch at a time on the Carriage side.

Push 1 needle on the Carriage side from A to B position.

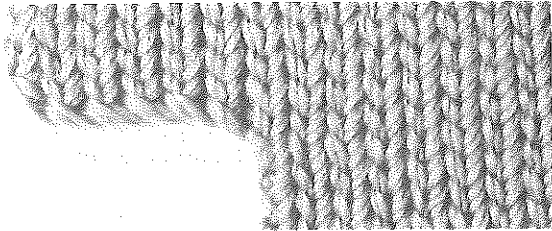
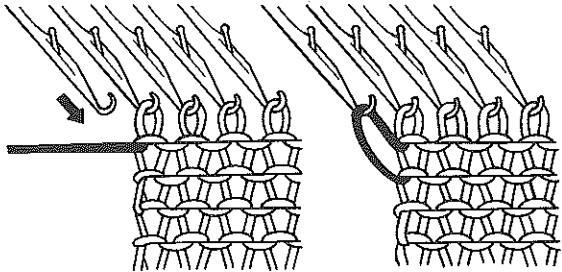

INCREASING MULTIPLE STITCHES

You can only increase on the Carriage side.

When the Carriage is at right side.

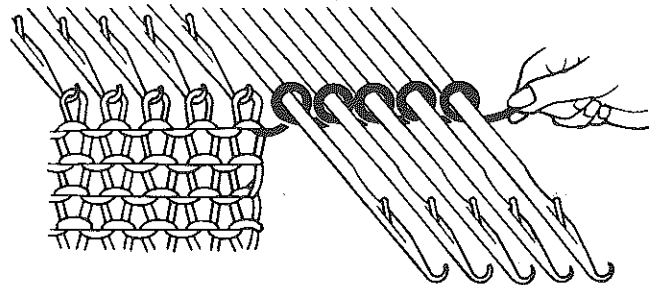
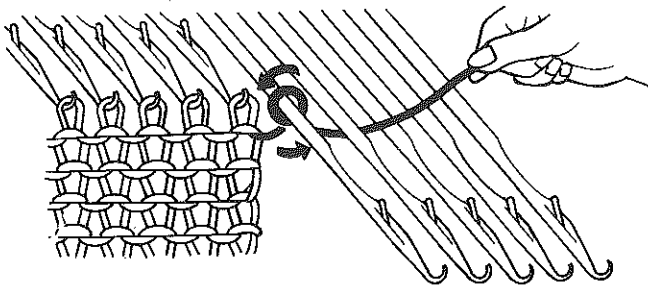

1. Push the required number of needles from A to D position.
Pull some yarn from the Yarn Feeder and wind it loosely around the empty needles in the anti-clockwise direction.

2. Push loops against sinker posts, eliminate slack yarn, and continue knitting.

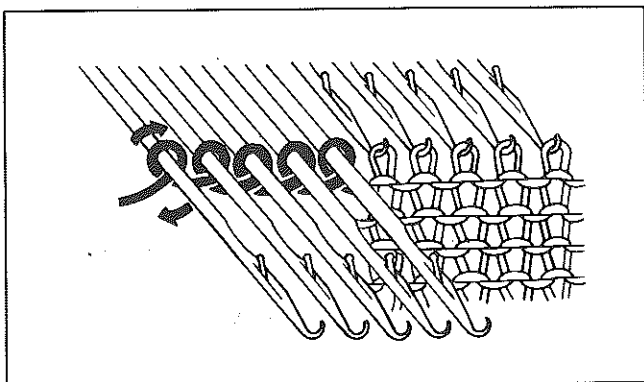

When the Carriage is at the left side, wind yarn around the needles in the clockwise direction.

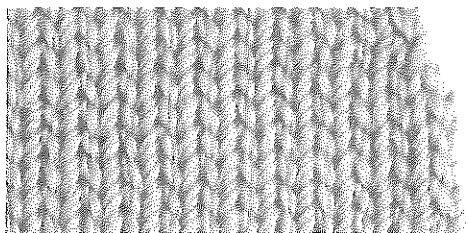

DECREASING 1 STITCH

You can decrease 1 stitch at both sides of the row.

Using the Transfer Tool, transfer the end stitch onto its adjacent needle.

Push back the empty needle to A position.

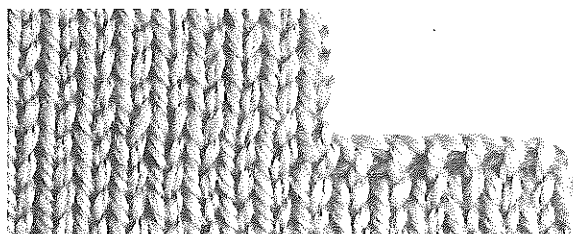
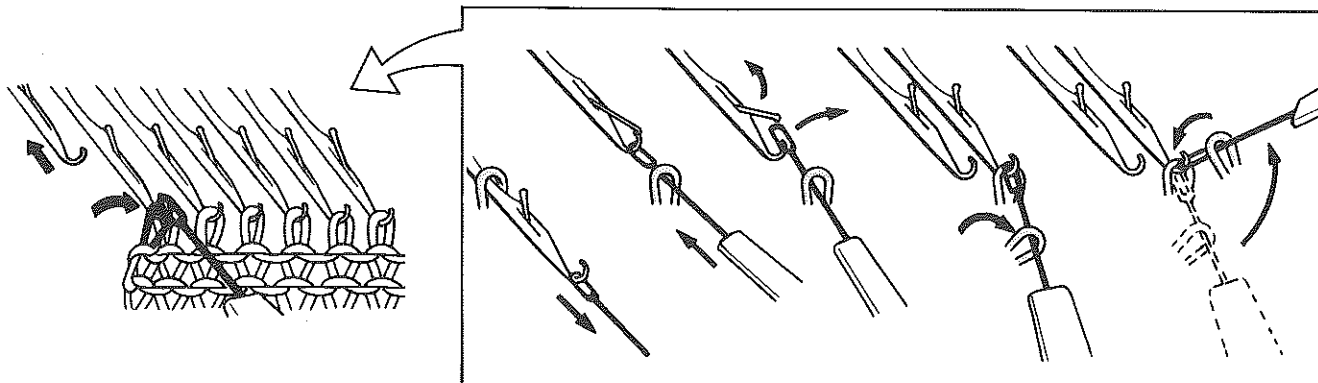

DECREASING MULTIPLE STITCHES

You can only decrease on the Carriage side.

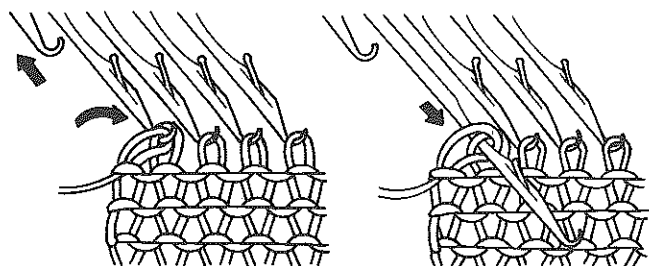

1. On the Carriage side, hold the fabric towards the Knitter. Transfer the end stitch to the adjacent needle. Push the empty needle to A position.

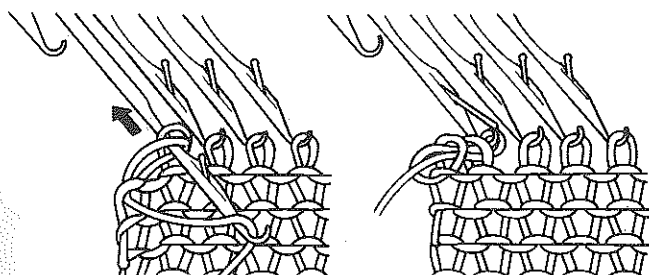

2. Push the second needle to D position until both stitches are behind the latch.

3. Lay yarn from right to left on the open hook of the needle.

4. Hold yarn slightly down and push the needle back to B position.

The two stitches slip off the needle.

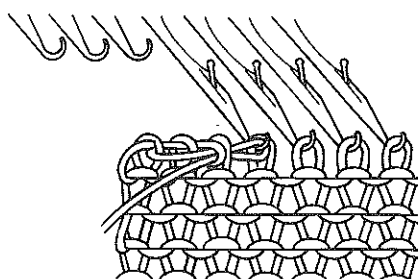

5. Continue the same procedure until the required number of stitches have been decreased.

Place the last decreased stitch onto its adjacent needle.

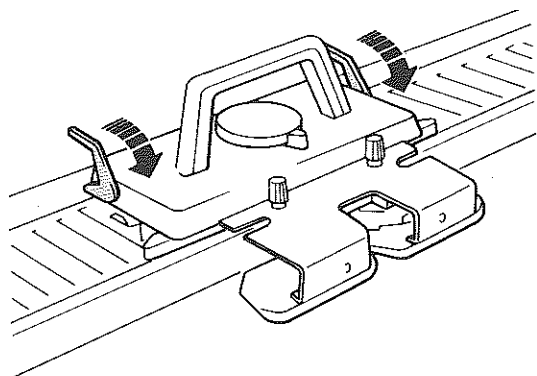

Passing the Carriage without knitting

- Turn the Feeding Levers toward you to stop the Row Counter and Knit Contour.

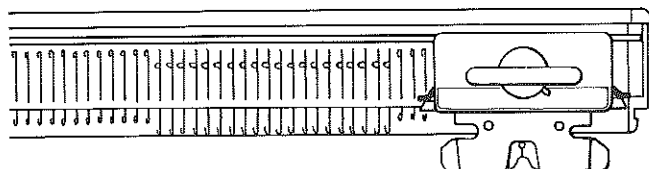

In case of the needles aligning in B position.

- Set the Cam Lever to "S" and move the Carriage.

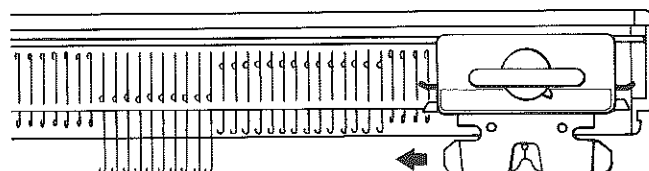

In case of the needles aligning in B and D position.

- Set the Cam Lever to "S" and Russel Levers to —, and move the Carriage.

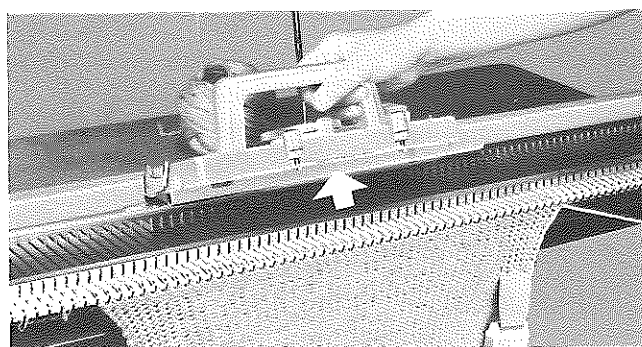

In any needle position, remove the Arm and move the Carriage while lifting its front.

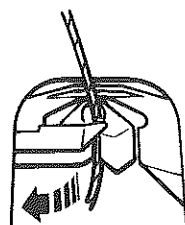

Removing the fabric from the machine

- Remove the yarn from Yarn Feeder.
- Break the yarn and hook its end onto the Yarn Clip.
- Remove weights from the fabric.
- Set Cam Lever to "O" and move Carriage across the fabric.

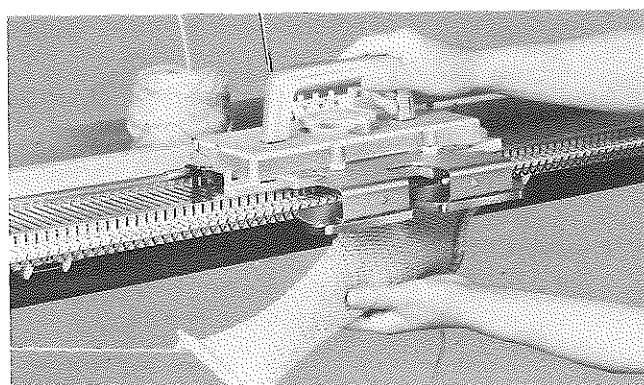

The fabric comes off of the needles.

PATTERN KNITTING

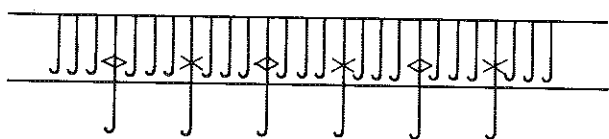
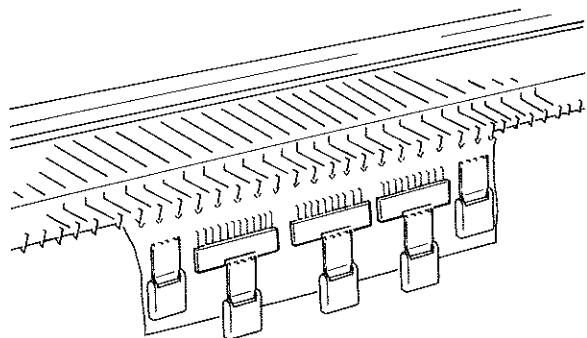
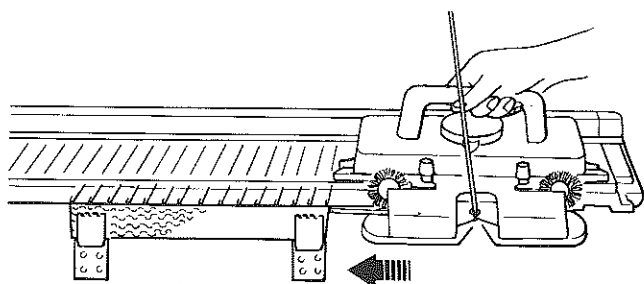

	①	②	③	④	⑤	⑥	⑦
6					=		→
5	■						→
4	■						→
3	■						→
2	■						→
1	◇	×	-	0	-	A	←

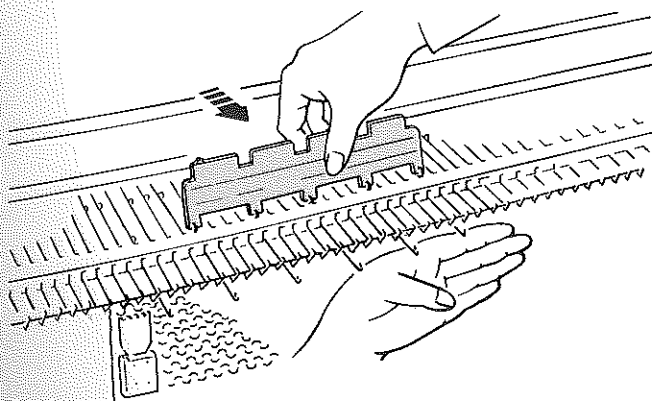

Getting to know about Pattern Knitting

* Before you start pattern knitting, knit 5 – 6 rows of Stockinet with main yarn or waste yarn.

* Start the Pattern Knitting from right side of the Needle Bed and move the Carriage at an even speed.

* It is recommended to hang the Claw Weight on the fabric if the stitches tend to become loose on the needles.

On the front edge of the needle bed, ◇ and × are marked alternately to help you select needles easily in relation to the Pattern Chart.

Pattern Chart

Follow the Pattern Chart from the bottom line.

Each column of the Chart indicates needle selection, Carriage settings, and knitting direction as detailed below.

- ① Knitting Order
- ② Needle position
 -needles in B position, or aligned back in B position from D position.
 -needles in D position.
- ③ Russel Lever (left)
- ④ Cam Lever
- ⑤ Russel Lever (right)
- ⑥ Main Yarn Feeder ("A" and "B" stand for different yarns)
- ⑦ Knitting Direction

* When you push the needles to D position, hold the fabric against the sinker post by hand.

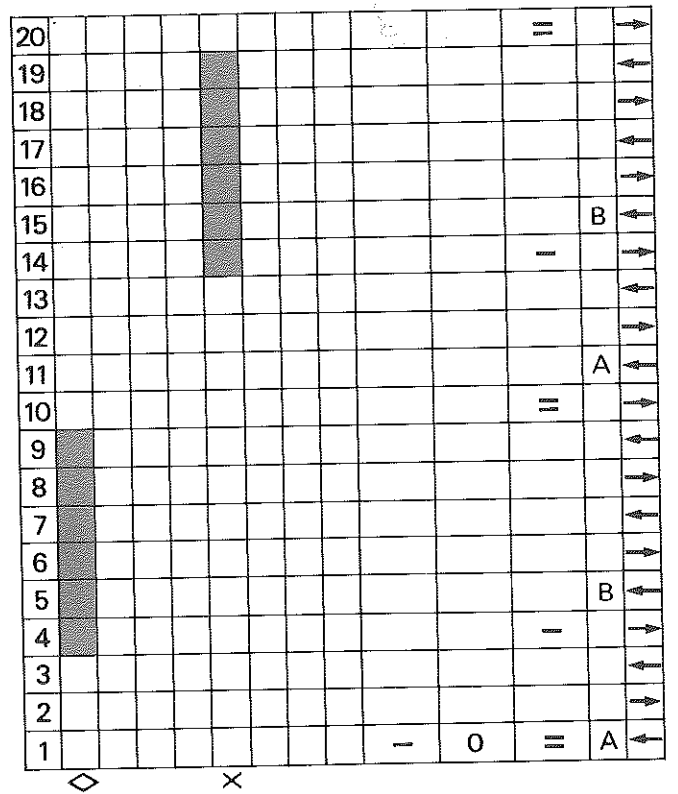
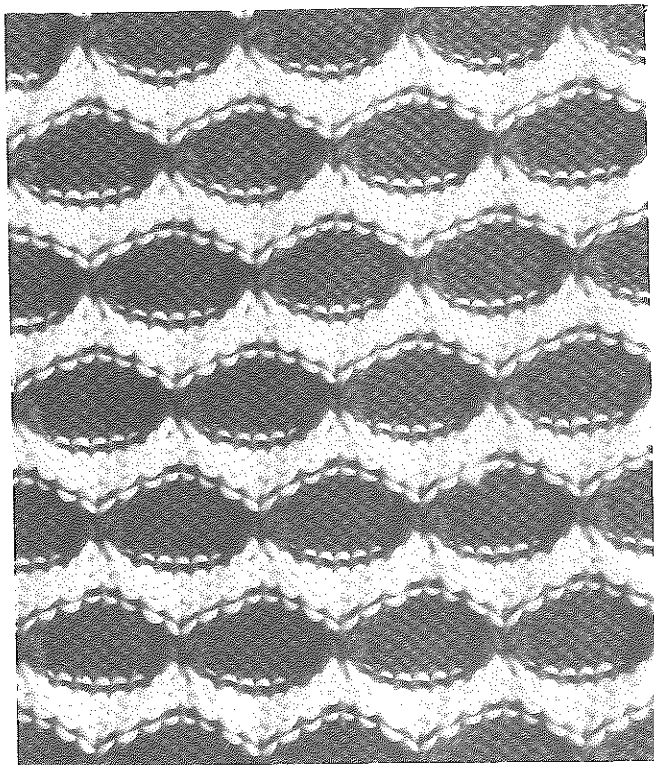
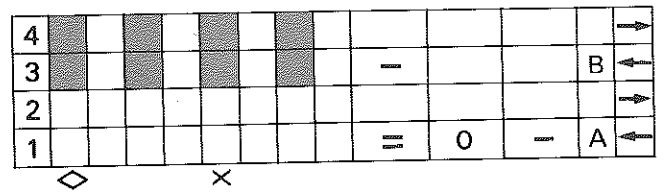
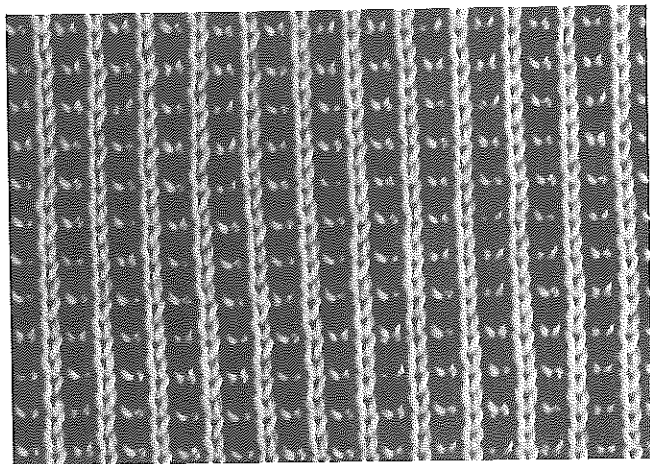
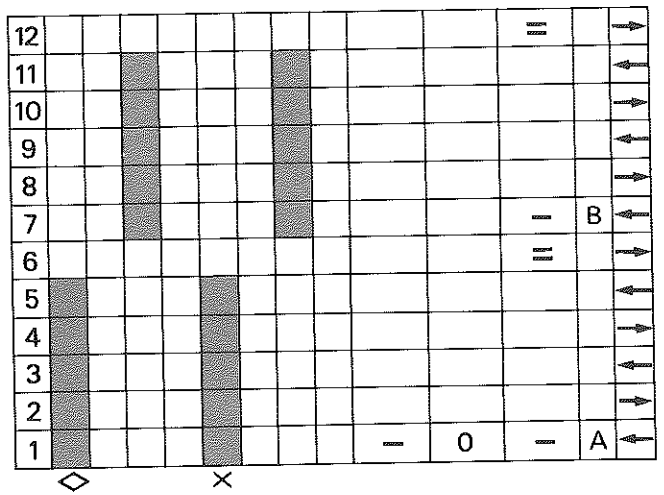
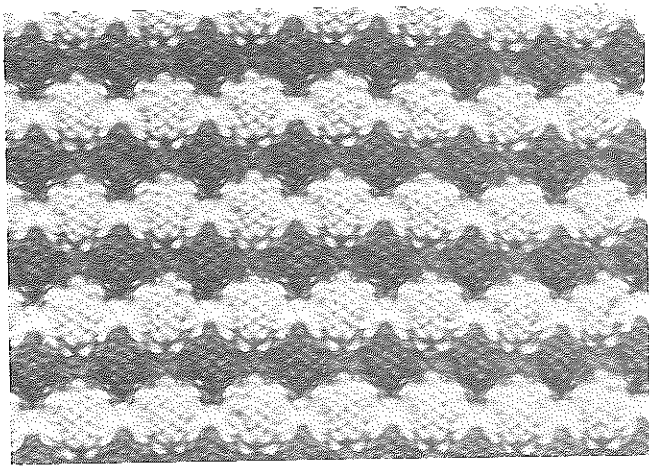

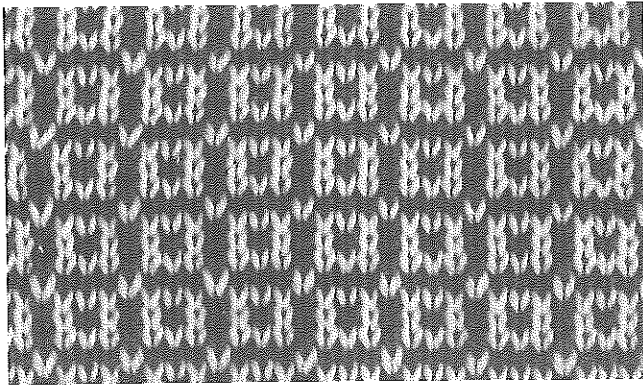

Knit-in (Fair Isle)

Prepare two different colour of yarns A and B, and knit the yarns alternately.

Thread the yarn A into the right Auto Tension and the yarn B into the left Auto Tension.

Knit the pattern following the Pattern Chart.

8																				A	→				
7																					←				
6																					B	→			
5																						←			
4																						A	→		
3																							←		
2																							B	→	
1																								A	←

◇ × = S =

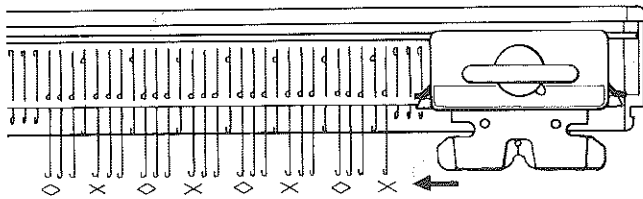

Order 1

- Set the Carriage as follows:–
 Cam Lever.....S
 Russel Levers.....= (both)
- Push up the needles from B to D position using 3/1 Needle Pusher.
- Thread the yarn A into the Main Yarn Feeder and knit 1 row.
- Remove the yarn from the Yarn Feeder and guide it under the Needle Bed to the right yarn rest at the right end of the Needle Bed.

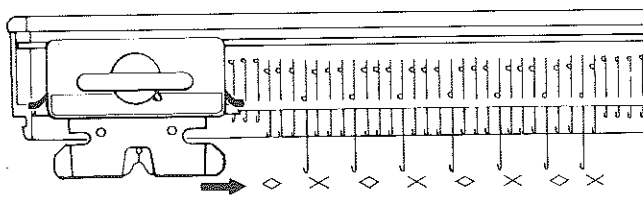

Order 2

- Referring to the Pattern Chart, push up the needles from B to D position using 1/3 Needle Pusher.
- Thread the yarn B into the Main Yarn Feeder and knit 1 row.

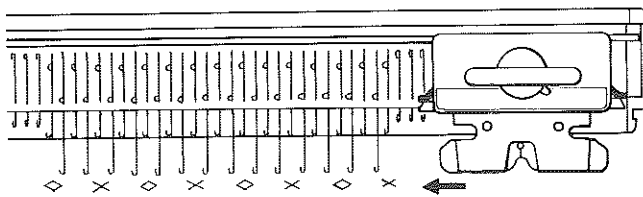

Order 3

- Referring to the Pattern Chart, push up the Needles from B to D position using 1/1 Needle Pusher and knit 1 row.
- Remove the yarn from the Yarn Feeder and guide it under the Needle Bed to the left yarn rest at the left end of the Needle Bed.

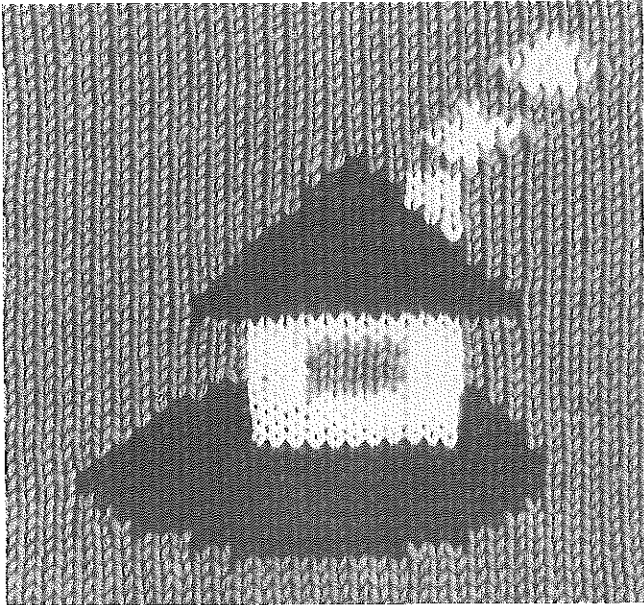





Intarsia Pattern

A practical method for knitting geometric or pictorial patterns without floats on the back of the fabric.

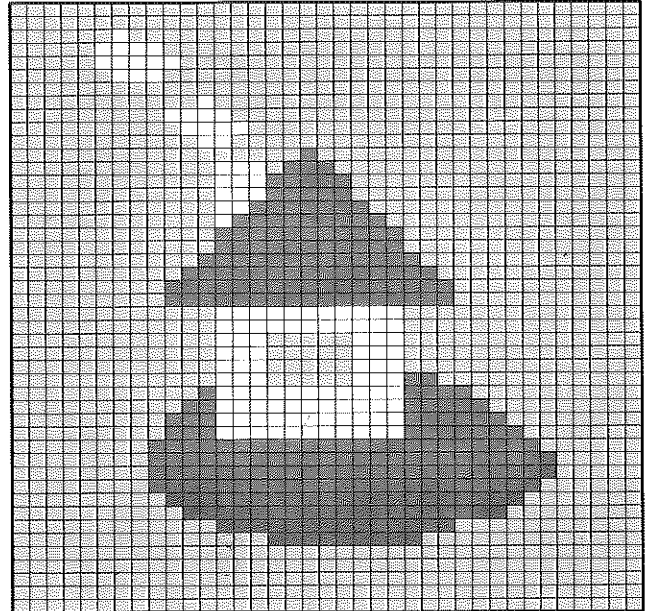
* If you own the Knit Contour Attachment, (option), it is recommended to draw a intarsia pattern on the Knit Contour Pattern Paper, and which will help you select needles on every row of knitting.

* As the wrong side is facing while you knit, draw patterns in reverse.



-  yarn A (background yarn)
-  yarn B (contrast yarn)
-  yarn C (contrast yarn)

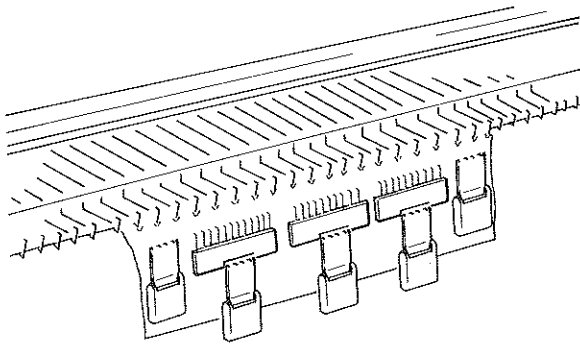

For practice knit following the Pattern Chart. It is necessary to prepare each colour of yarn would into each separate ball before starting to knit.

Prepare 3 balls of yarn A, 2 balls of yarn B and C.

- Cast-on 37 stitches with waste yarn and knit 10 rows ending at left.
- Hang Comb Weight and Claw Weights and remove the Tuck Brushes from the Arm.

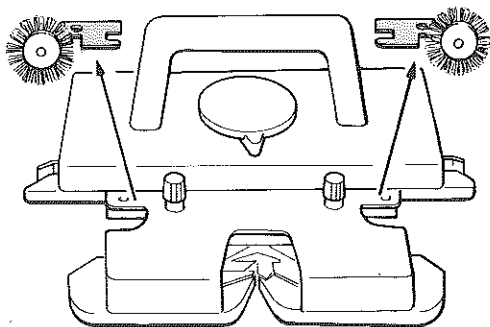

IMPORTANT

Be sure to remove the Tuck Brushes from the Arm before setting the Cam Lever to "I".

- Knit 5 rows with yarn A.
- Remove the yarn from the Yarn Feeder and Auto Tension, and place the yarn balls on the floor.

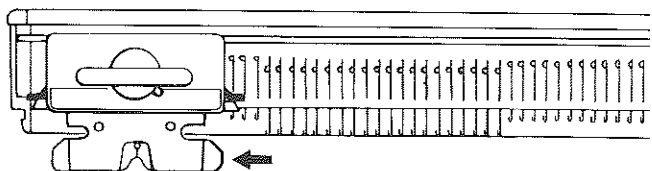

- Set the Cam Lever to "S" and move the Carriage to the left.

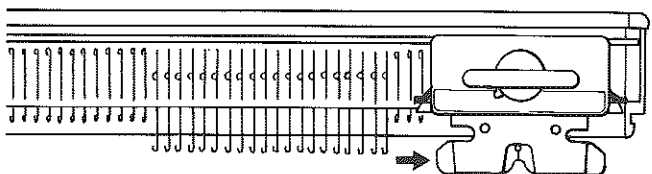

- Set the Cam Lever to "I" and move the Carriage to the right.
(The needles will be aligned in C position.)

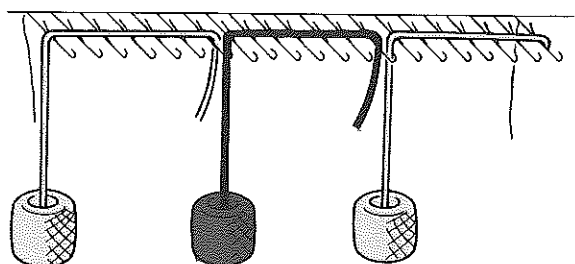

- Following the Pattern Chart, lay yarns A and B on the opened hooks starting from the Carriage side.

Be sure to open latches of the needles before laying yarn.

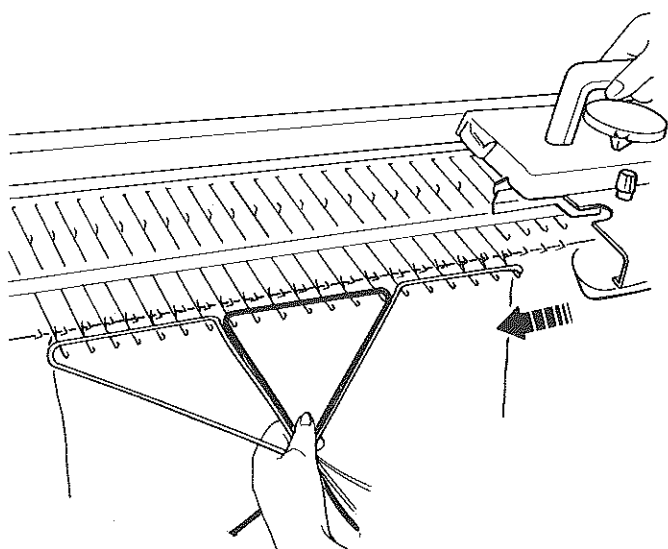
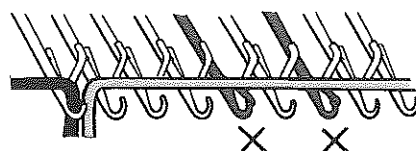

- Holding down the yarns gently only to take up slack from the yarns, and move the Carriage slowly across the needles to knit the first row.

The needles align in C position.

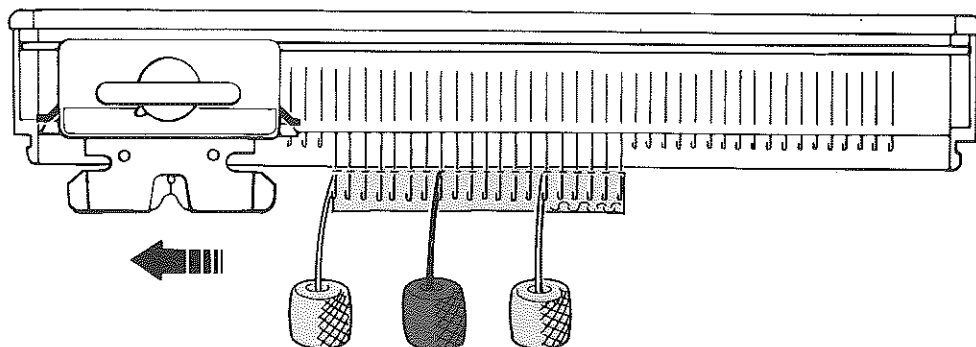

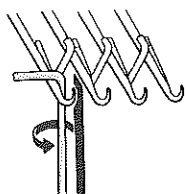
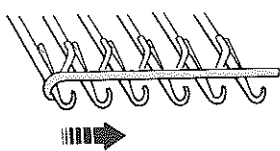

– Lay yarns on the needle hooks starting from the Carriage side.

To avoid separation of stitches at the edge of each colour yarn, cross yarns as illustrated.

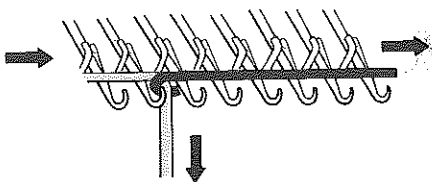
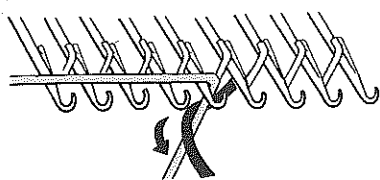

– Holding the yarns gently only to take up slack from the yarns, and move the Carriage slowly across the needles to knit the second row.

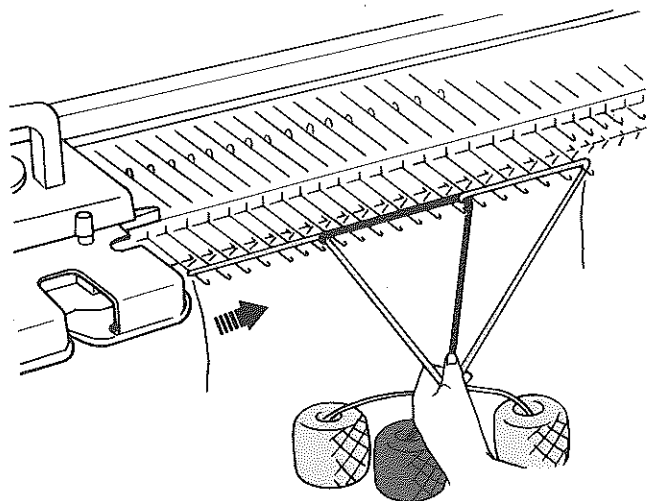

– Following the Pattern Chart, continue knitting by laying the yarns on the needle hooks as done for the first and second rows.

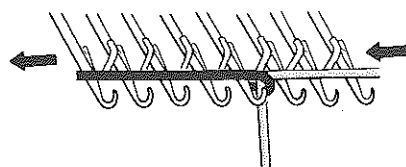

– To knit only 1 or 2 stitches in one colour, lay the yarn on those needles and push them by hand back to B position.

– Continue to knit by laying the yarns on the needle hooks omitting the needles knitted by hand.

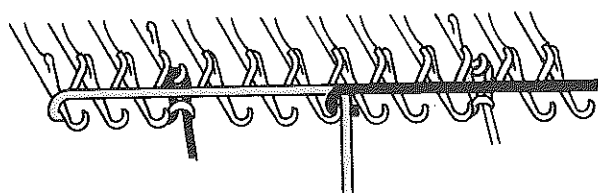

How to knit Stockinet

– Lay the main yarn "A" on hooks of the needles in C position before moving the Carriage.

– Move the Carriage, knitting a row.

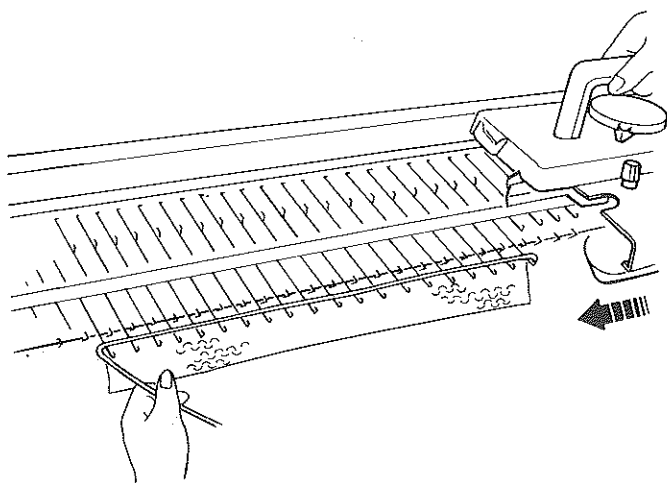

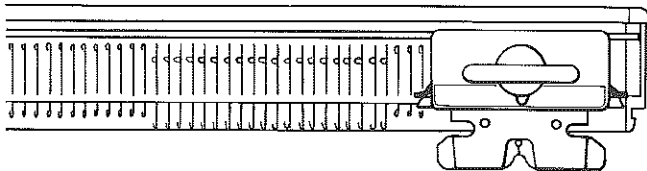
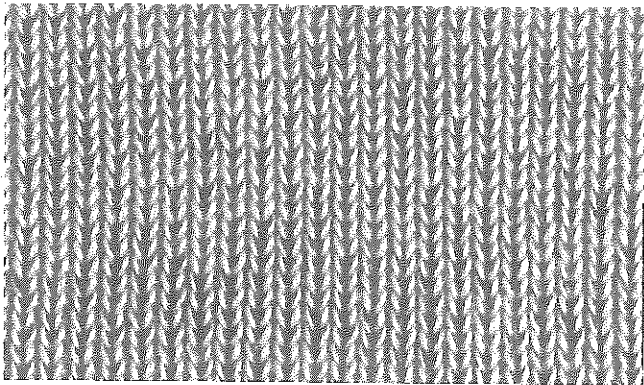

Plating

Two different colour yarns are knitted together. One yarn appears on one side while the second yarn appears on the other side of the fabric.

Since two yarns are knitted together, use thinner yarns than those for the other patterns, and Stitch Dial must be set at the number which totals the stitch dial number for each type of yarn used.

– Cast-on with waste yarn or either of two yarns.

– Set the Carriage as for the Stockinet.

Cam Lever..... 0

Russel Levers = (both)

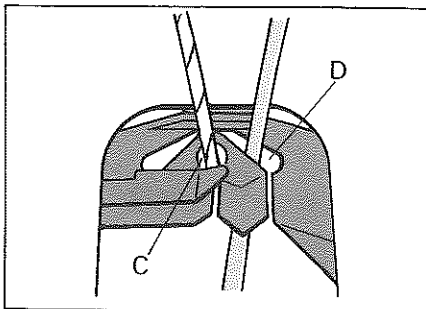
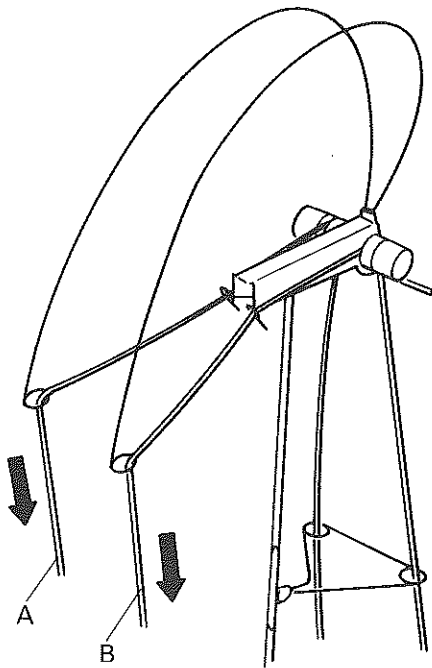

– Thread the main yarn "A" into the left side Auto Tension and the plating yarn "B" into the right one.

– Set the main yarn into the Main Yarn Feeder C and plating yarn into the Plating Yarn Feeder D.

– Knit in the same manner as done for stockinet.

Main yarn appears on knit side and plating yarn appears on purl side.

TAKING A TENSION GAUGE

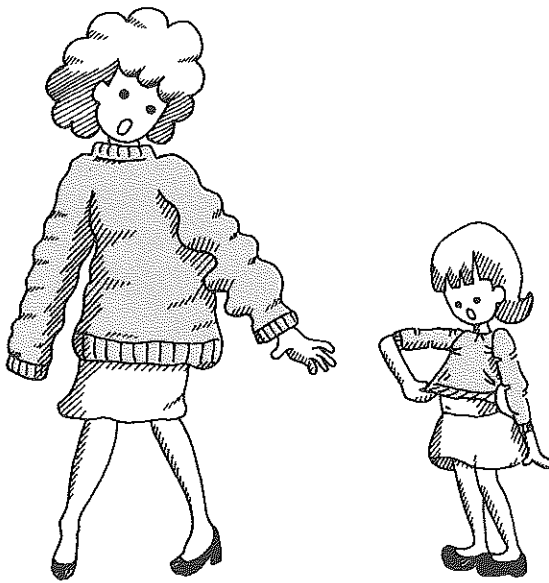

Tension Gauge

In order to knit a garment correctly to desired size, a tension gauge is very important to know how many rows and stitches are required in selected stitch type and stitch dial.

Tension Swatch

The tension swatch is knitted with the same yarn and in the same stitch type as to be used for the garment.

The procedure below to knit the tension swatch is pre-determined for calculating the tension gauge using the Gauge Scale.

It is recommended to try knitting by changing Stitch Dial settings till you obtain suitable stitch dial number for the yarn and stitch type.

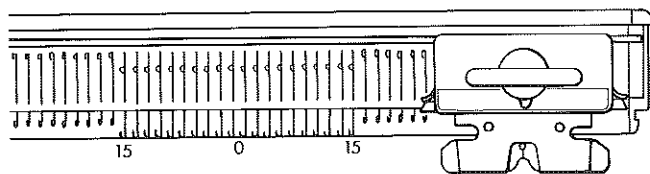

- (1) Arrange 15 needles on both sides of the centre(0), 30 needles in total for cast-on.

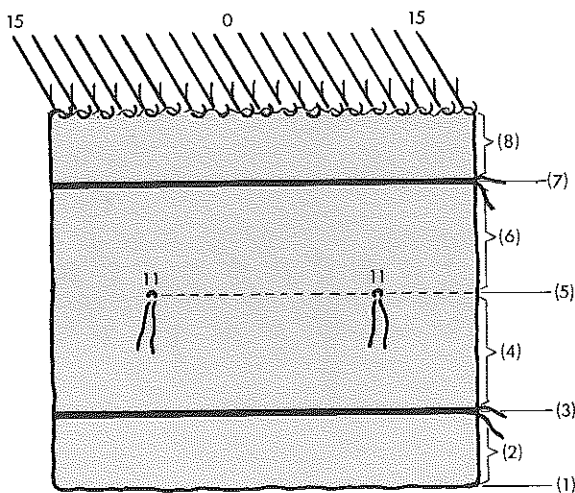

- (2) Cast-on with main yarn and knit 10 rows continuously in selected stitch type with suitable Stitch Dial.

- (3) Exchange the main yarn in the Yarn Feeder for the contrast yarn, and knit two rows in stockinet.

- (4) Cut the contrast yarn and rethread the main yarn, and knit 15 rows in selected stitch type with suitable Stitch Dial.

- (5) Push up both 11th needles from the centre(0) to D position and place a piece of contrast yarn on each of those needle hook. Then push those needles back toward B position by hand.

- (6) Knit another 15 rows.

- (7) Thread the contrast yarn and knit 2 rows in Stockinet.

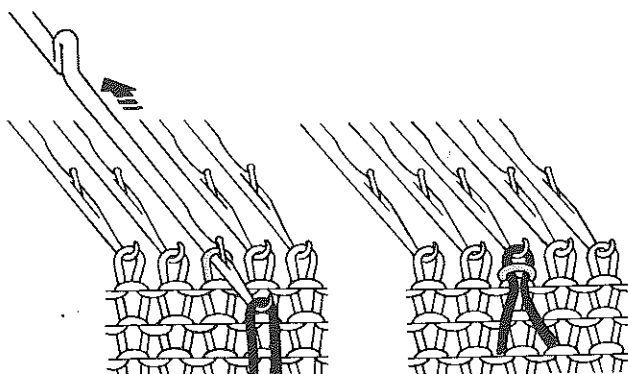

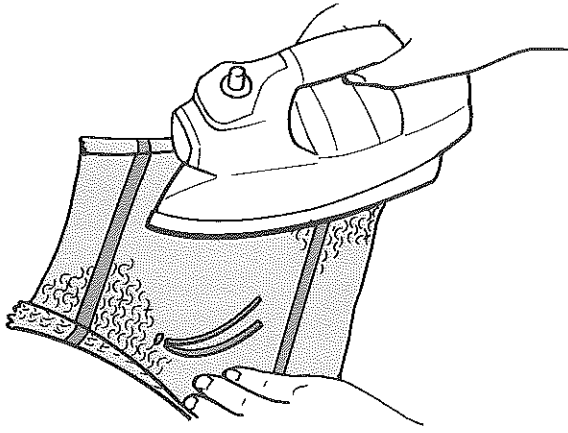

(8) With main yarn, knit 10 rows in selected stitch type with suitable Stitch Dial.

Remove the yarn from the Yarn Feeder and remove the swatch from the machine by moving the Carriage once.

TAKE NOTE OF THE STITCH DIAL NUMBER.

(9) Allow several hours for the swatch to return to its natural condition. Press the swatch lightly with a steam Iron, or with an ordinary iron over a damp cloth.

In case of every other needle selection

When you knit a garment using every other needles, count the number of needles for knitting a tension swatch by omitting the non-knitting needles, and also put yarn marks at the position marked by arrows as shown below.

Needle arrangement

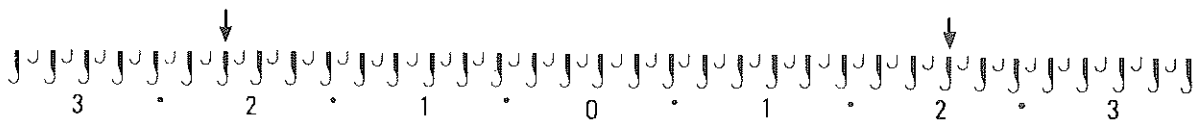

Yarn mark

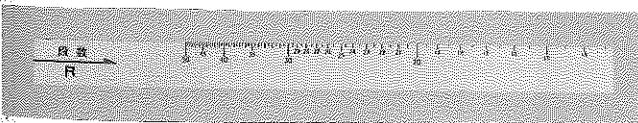
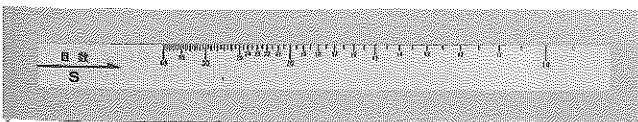
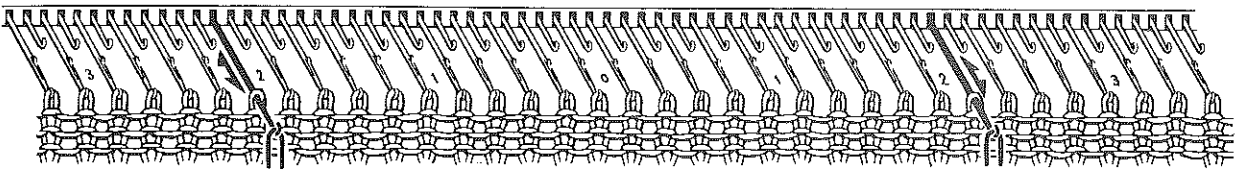

Gauge Scale

This scale is so designed as to measure the length of 30 rows and the width of 20 stitches of the tension swatch, and designate them as so many stitches and rows per 10cm.

The scale is two sided. The side "S" is used for measuring stitches and the side "R" is for rows.

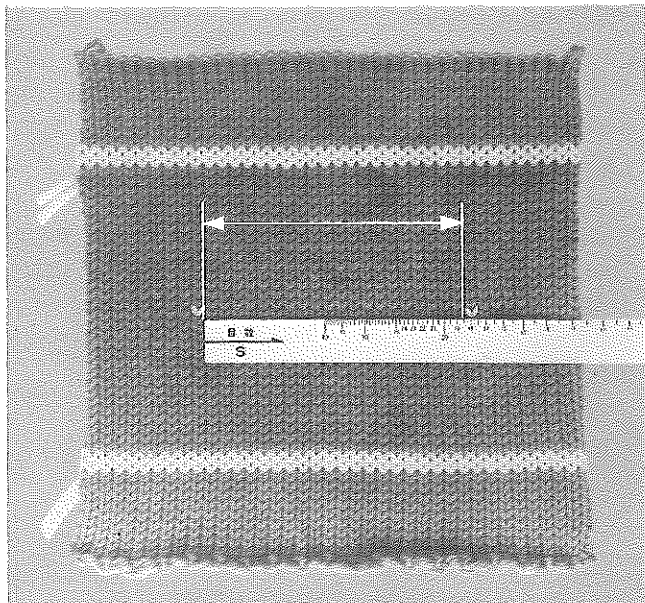

How to measure the tension swatch

Stitch (Horizontal)

Place the Gauge Scale, with the "S" side up, onto the tension swatch so as the left end of the Scale is touching the inside of the stitch in a contrast yarn. Measure to the point of the other contrast stitch and the number which corresponds with this stitch. The Scale should be read from the side indicated by the arrow, i.e. from the left side.

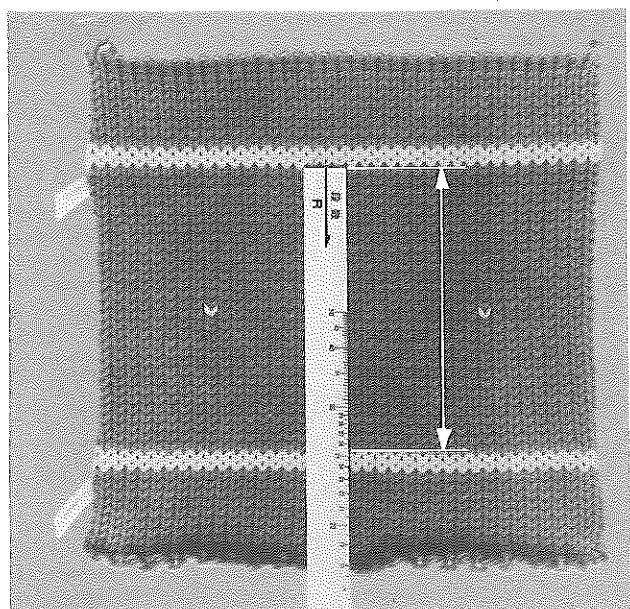

Row (Vertical)

Place the Gauge Scale, with the "R" side up, onto the tension swatch so as it covers the length in between the rows knitted in a contrast yarn. Measure this length and the number indicated on the Scale. The Scale should be read from the side indicated by the arrow.

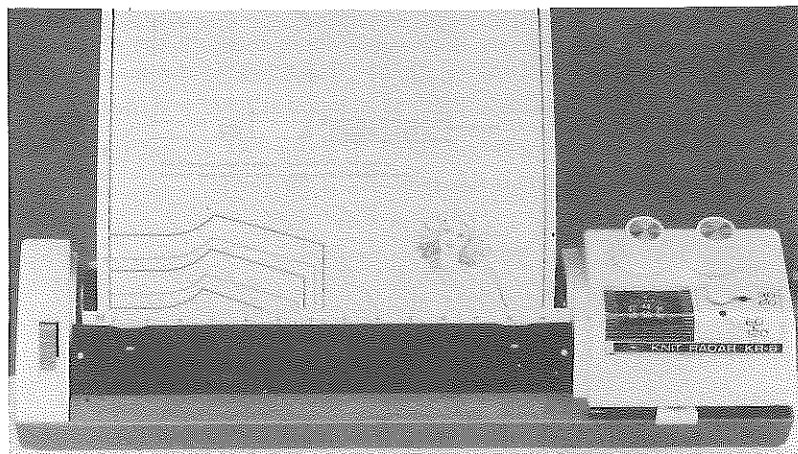

KNIT CONTOUR ATTACHMENT (OPTION)

The Knit Contour Attachment optionally available helps you counting stitches and rows for shaping garment. 19 different pre-printed pattern styles come with the attachment.

For use of this attachment with this machine, refer to the page to follow.

HOW TO ATTACH KNIT CONTOUR ATTACHMENT

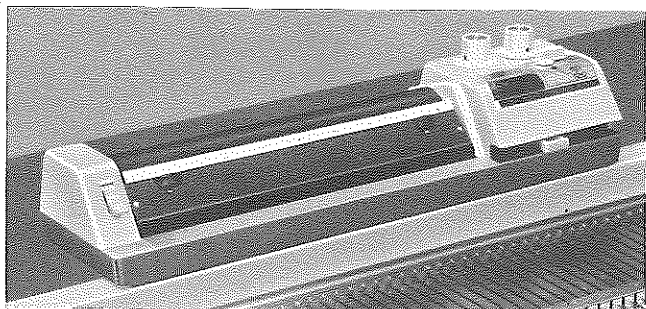

If you own the Knit Contour Attachment, attach it on the machine and set it for operation as follows:—

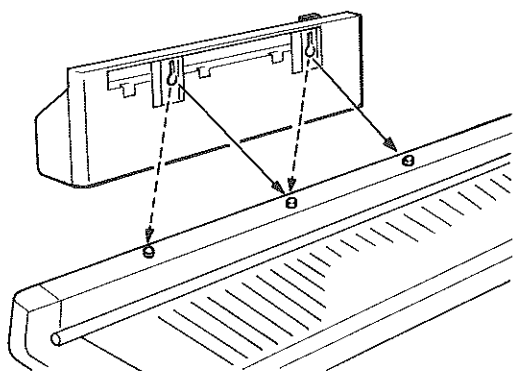

Fit the slots at the underside of the Knit Contour Attachment to the two of those three fixing pins on the case of the needle bed.

If the tension swatch has been knitted in the manner as described in this book, use the Gauge Scale of blue colour for measuring the tension gauge.

If the tension swatch has been knitted as described in the instruction book for the Knit Contour Attachment, use the Gauge Scale of green colour which comes with the attachment.

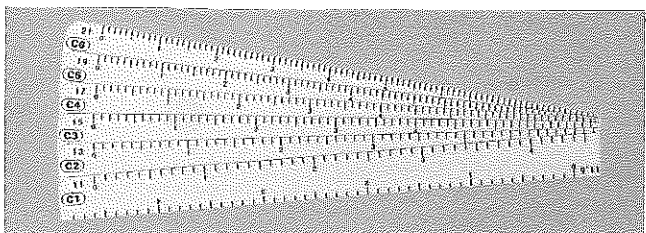

Stitch Scale

Select a stitch scale with the number equal to the number read on the blue Gauge Scale, and set it in the Knit Contour Attachment.

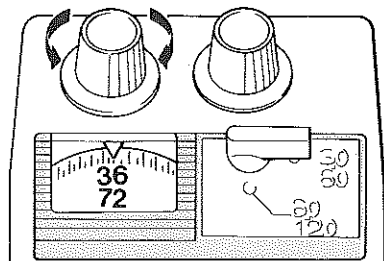

Row Number

If the tension gauge is less than the lowest limit, 30 rows, select a number twice the row number read on the Gauge Scale.

(Example: If 18 rows is read on the Gauge Scale, select 36 on the row number scale of the Knit Contour Attachment)

Raise both feeding levers at both sides of the Carriage.

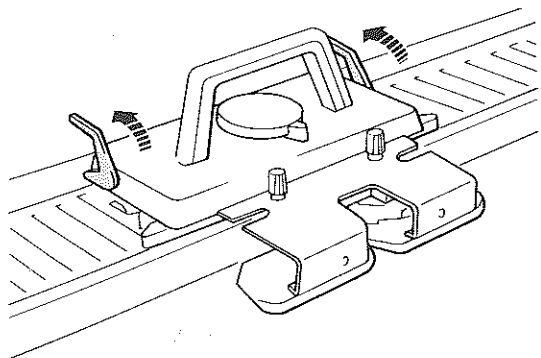

Note: If the tension gauge is no less than 30 rows, select the same number on the Row Number Scale and lay down the KC Lever (left feeding lever) in knitting.

HOW TO KNIT A GARMENT — Lady's pullover —

The instruction below explains how to knit a garment without using the Knit Contour.
A pullover is taken as an example based on the size and the tension gauge as shown below.

Measurements of finished garment

Bust 96cm.
Length..... 59cm.
Back Width 37cm.
Sleeve Length..... 56cm.

Material needed: Extra thick yarn..... 500gs.

Tension Gauge: 16 stitches by 22 rows to 10cm. sq. measured over Stockinet with the Stitch Dial at 5.

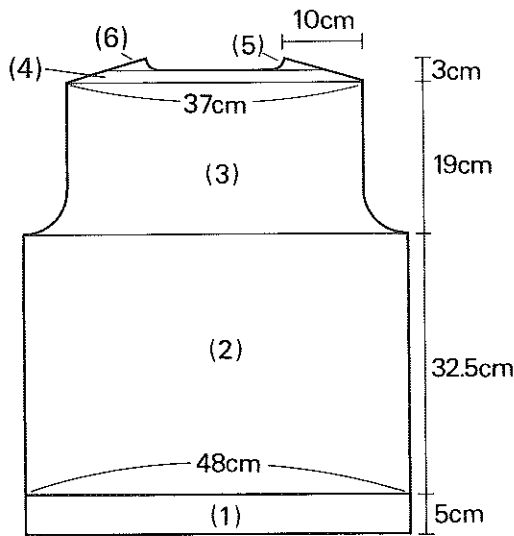

Back

(1) To knit waistband

- Arrange 80 needles and knit waistband by K1.P1. Rib.
(K1.P1. Rib. — page 45: on step 3, knit 4 rows starting from the right side, and on step 6, set the Row Counter to 000, turn the right Feeding Lever and knit 12 rows.)

(2) To knit straight up to the armhole

- Stitch Dial 5, knit 72 rows without shaping. (Row Counter at 84) Carriage at the right side.

(3) To shape armhole

- Decrease 5 stitches at the beginning of next 2 rows and 2 stitches of next 2 rows.
(Decreasing multiple stitches — page 16)
- Decrease 1 stitch at both ends of next and following alternate rows, 3 times in all till the Row Counter shows 94.
(Decreasing 1 stitch — page 16)
- Knit 20 rows without shaping. (Row Counter at 114) Carriage at right side.

(4) To shape shoulder by partial knitting

- Set the Russel Levers to —, push up 4 needles on the left side to D position and knit 1 row.
- Push up 4 needles on the other side to D position and knit 1 row.
(Partial knitting by decreasing stitches — page 43.)

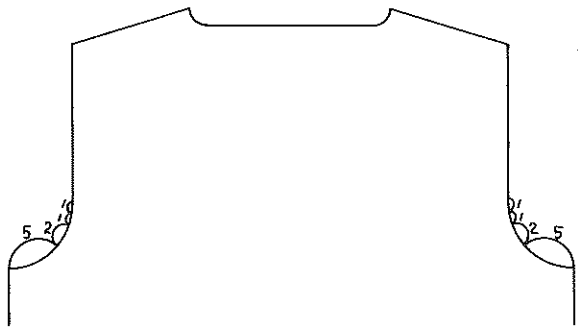

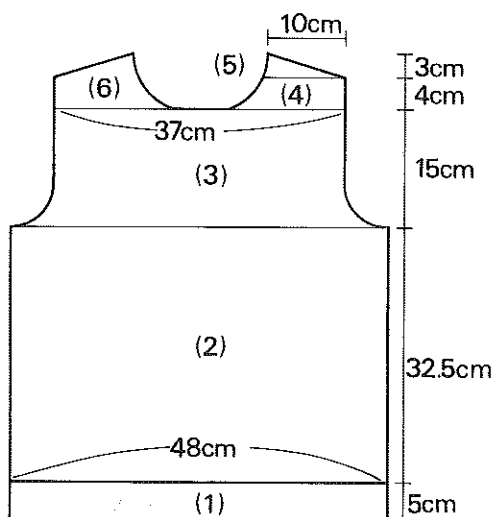
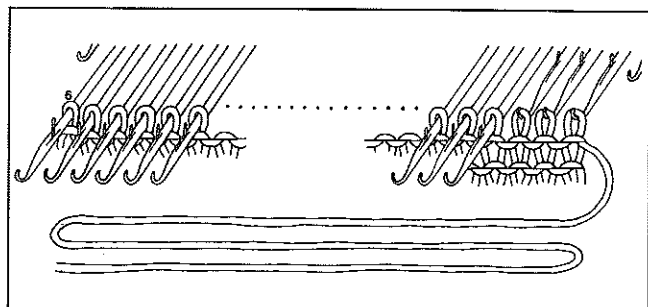
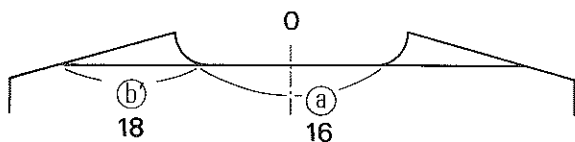
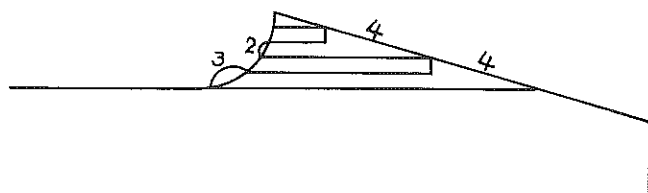
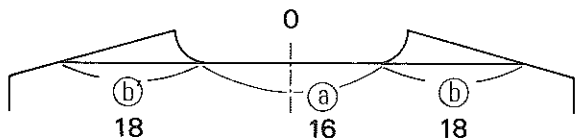

(5) To shape neck edge and right shoulder

At the neck line, divide into three sections, right (b), centre straight (a), and left (b), and work each section separately to shape the neck edge and shoulder at the same time, as instructed below.

- Push up 34 needles on section (a) and (b) to D position. *(Holding stitches on D position – page 50)*
- Knit 1 row and Decrease 3 stitches at the neck edge. *(Decreasing multiple stitches – page 16)*
- Decrease 4 stitches on the shoulder side by partial knitting. *(Partial knitting by decreasing stitches – page 43)*
- Knit 1 row and decrease 2 stitches at neck side.
- Decrease 4 stitches by partial knitting.
- Knit 1 row. (The Carriage at left side and Row Counter at 121)
- Break the yarn leaving the end 10cm. and unthread the yarn.
- Push back the needles for the right shoulder to C position.
- With waste yarn, knit several rows and remove the section from the machine.
- Push back the empty needles to A position.
- Push 16 needles on section (a) back to C position.
- Put a yarn mark at the centre(0) of the Needle Bed. *(Put yarn mark – page 52)*
- Remove the section on waste knitting and push back the empty needles to A position.

(6) To shape neck edge and left shoulder

- Push back the needles of section (b) to C position.
- Have the Carriage on the left side of the fabric, and work section (b) as done for the section (b) but in a reverse shaping.
- Break the yarn leaving the end three times the width of the shoulder, and unthread the yarn.

Front

(1) – (3) To knit up to the neckline

- Knit in the same manner up to the neckline as done for the back will the Row Counter shows 94.
- Knit 10 rows without shaping Carriage at the right side. (Row Counter 104)

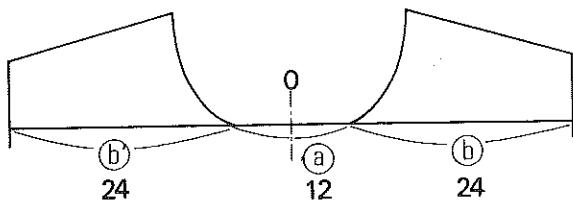

(4) To shape front neckline of right section

- Set the Russel Lever to —.
- Push up 36 needles on section (a) and (b) to D position.

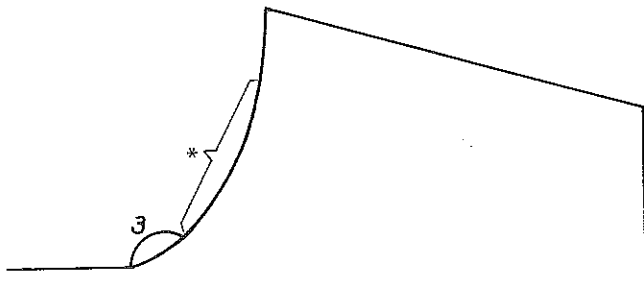

- Knit 1 row and decrease 3 stitches at the neck edge and knit 1 row.
- Decrease 1 stitch at the beginning of the next and every following alternate rows, 4 times in all (*). (Row Counter at 114)

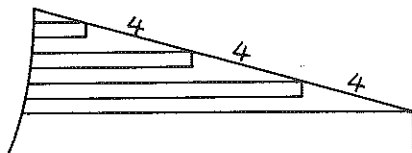

(5) To shape right shoulder

- Work partial knitting by decreasing stitch in the same manner as done for back.
- Push back the needles for the right shoulder to C position.
- Remove the section on waste knitting.
- Break the yarn leaving the end three times the width of the shoulder and unthread the yarn.

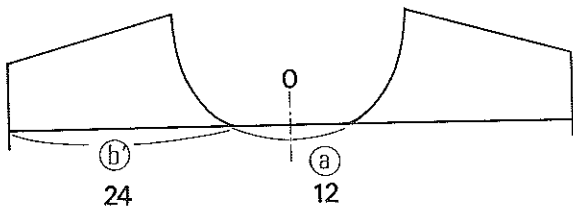

(6) To shape neck edge and left shoulder

- Push back 12 needles on section (a) to C position.
- Put a yarn mark at the centre(0) and remove the section on waste knitting.
- Work section (b) in the same manner as done for the section (b) but in a reverse shaping.
- Break the yarn leaving the end 10cm.

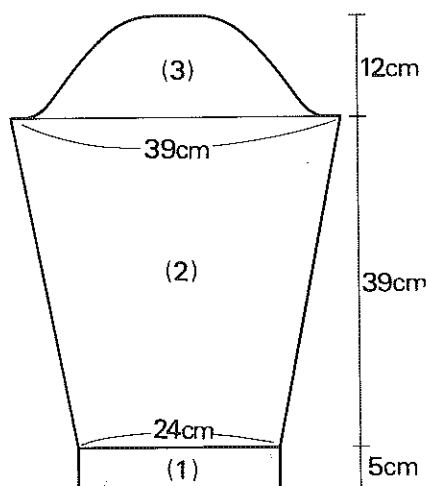

Sleeves (both alike)

(1) To knit cuff

- Arrange 40 needles and knit in the same manner as done for the waistband.

(2) To shape underarm

- Stitch Dial 5, increase 1 stitch at both ends of the next and every following 6th row, 5 times and 7th row 7 times in all until the Row Counter shows 97. 64 stitches remain on the Knitter.

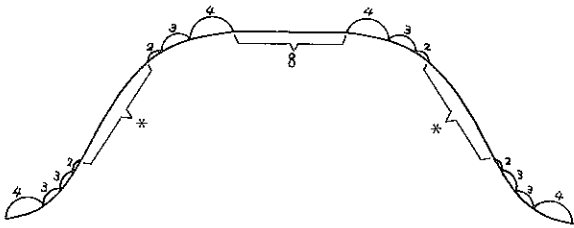

(3) To shape sleeve top

- Decrease 4 stitches at the beginning of the next 2 rows, 3 stitches of the next 4 rows, and 2 stitches of the next 2 rows.
- Decrease 1 stitch at both ends on the next row and every following alternate row, 7 times in all (*).
- Decrease 2 stitches at the beginning of the next 2 rows.
- Decrease 3 stitches of the next 2 rows.
- Decrease 4 stitches of the next 2 rows. (Row Counter at 125)
- Put a yarn mark at the centre(0) and cast off the remaining 8 stitches by using back stitch method.
(Joining on the machine, step 6 – page 56)



Neckband

- Arrange 68 needles for K1.P1. Rib and knit 7 rows as done for the waistband.
- Remove the neckband on waste knitting.
- Break the yarn leaving the end three times the width of the neckband and unthread the yarn.

Blocking and pressing

After knitting the pieces of your garment, you must lay them flat and pin them out to their correct shape and size.

- Pin out a piece with its wrong side facing up on an ironing board at the widest point, afterwards pinning it to its correct length.
- Pin all around the edges, spacing the pins about 2–3cm. apart. (Place the pins inside the ribbed edge.)
- Press them lightly with a steam iron or over a damp cloth.
- Leave the pieces to dry before removing the pins.

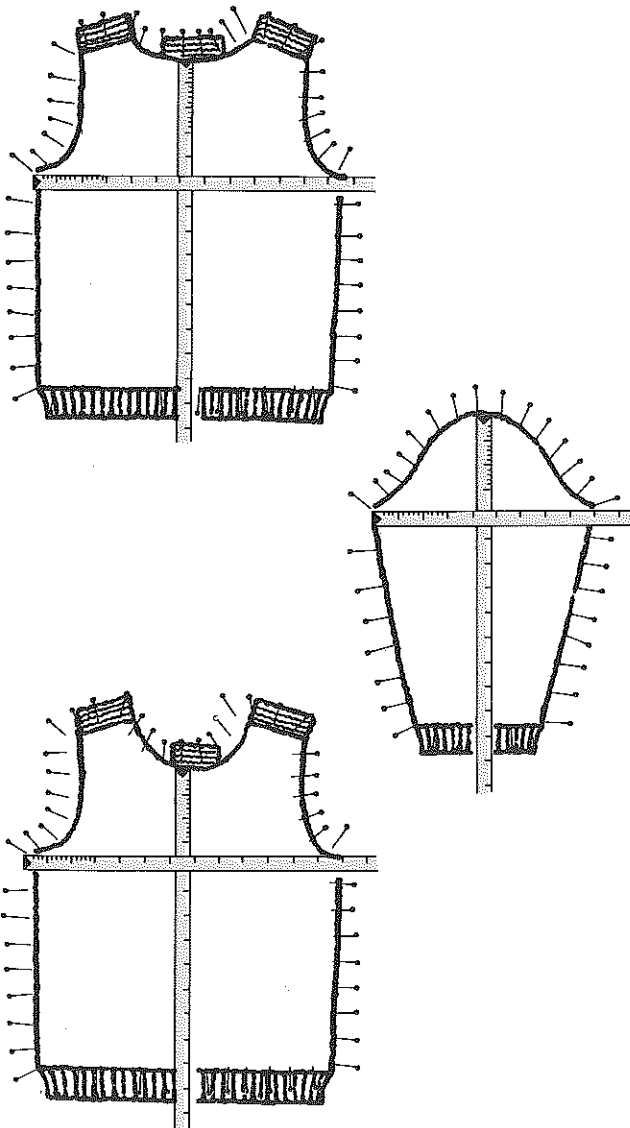

Making up

- Join the right shoulder on the machine using the yarn end.

*(Joining on the machine, stitch to stitch – page 55.)
(Replace the back shoulder on the needles first.)*

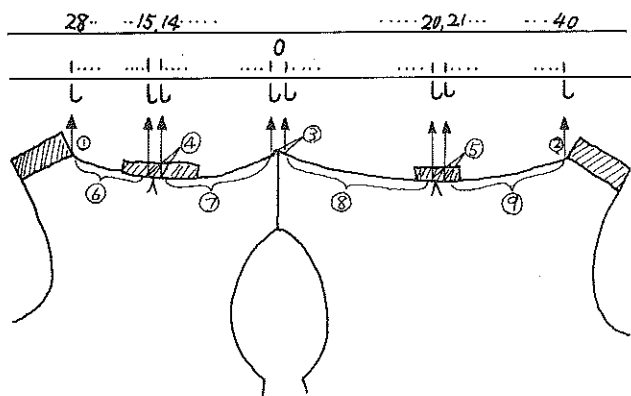
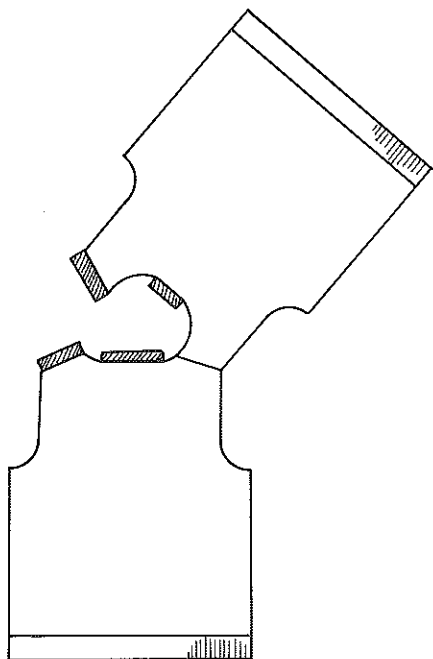

- Join the neck edge and neckband on the machine.

(Joining on the machine, open stitch to side edge – page 57.)

- Arrange 40 needles on right side of centre (0) for the front neck edge and 28 needles on left side for the back.

• With right side facing, hang neck edge in the order as illustrated.

• With wrong side facing, hang the neckband.

- Pick up and finish off the left shoulder to correspond with the right shoulder.

- Join the side, neckband and sleeve seams.
(Blind stitch – page 58)

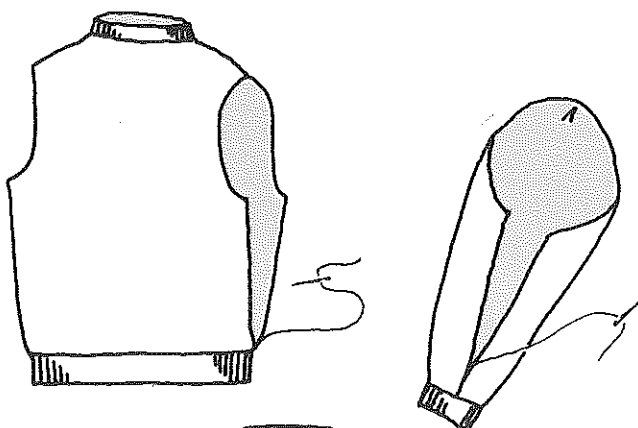

- Turn the garment to the wrong side and slip the sleeves into the armhole. Pin them as illustrated and work slip stitch along the edges.
(Slip stitch – page 59)

- Sew in yarn ends on the wrong side.
(Sew in yarn end – page 59)

- Give final press.

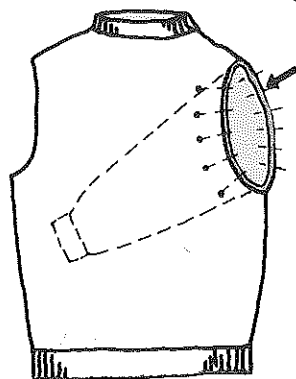

KNITTING TECHNIQUES

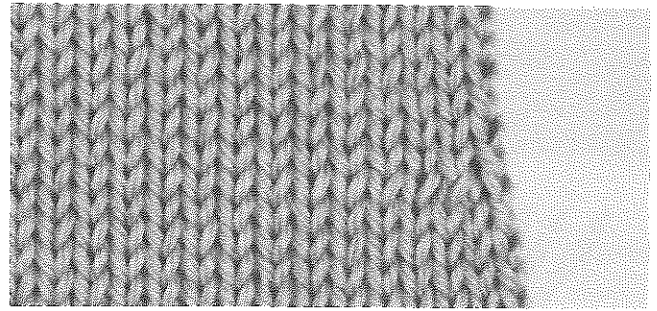
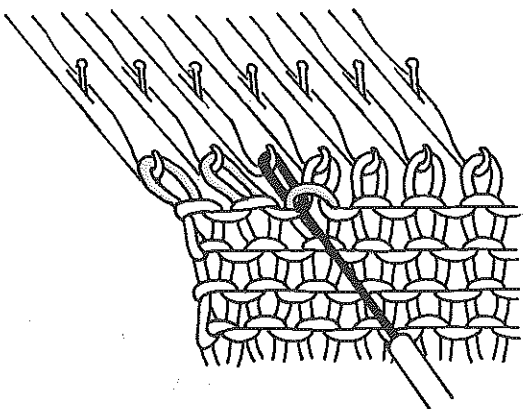
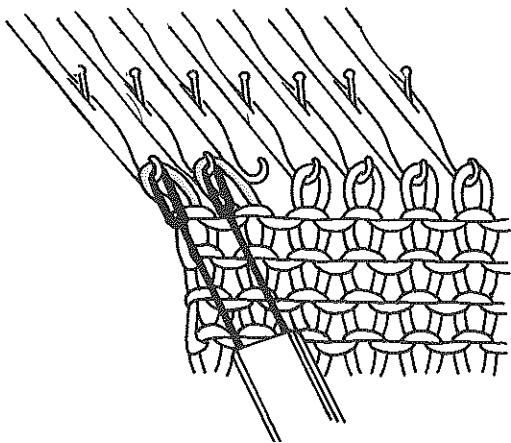
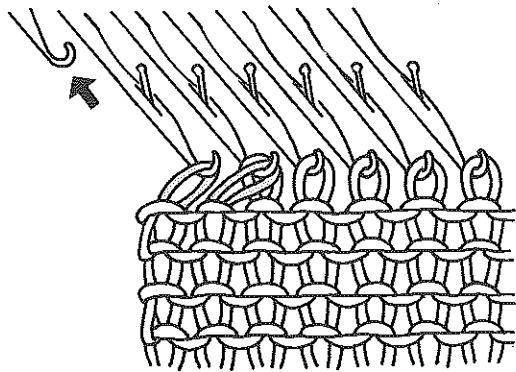
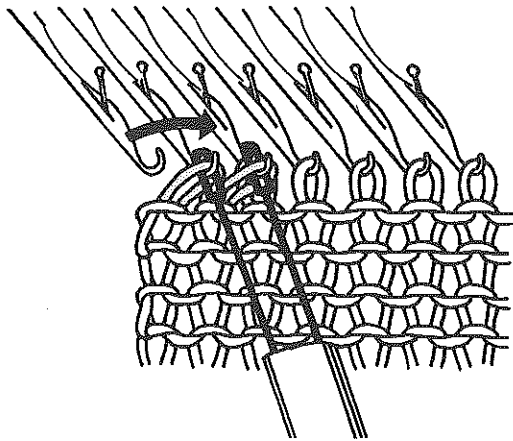

Fully fashioned decrease

1. With two prong Transfer Tool, transfer the two end stitches onto one needle inside.
In case of every other needle selection, use three prong Transfer Tool.
2. Push the end empty needle back to A position.
Continue to knit.

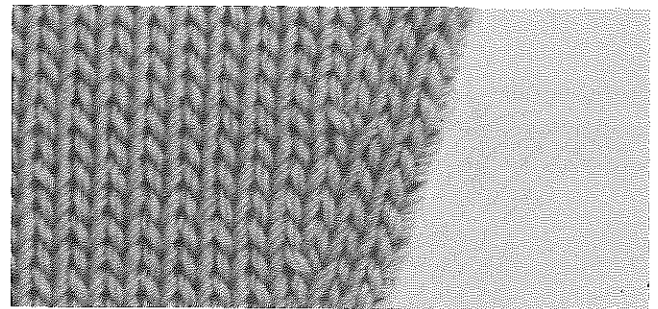

Fully fashioned increase

1. Adjacent to the end stitch push an empty needle up into B position. With 2 prong Transfer Tool, transfer the two end stitches one needle out.
In case of every other needle selection, use three prong Transfer Tool.
2. Pick up the loop below the third stitch and place it onto the empty needle as shown.
Continue to knit.

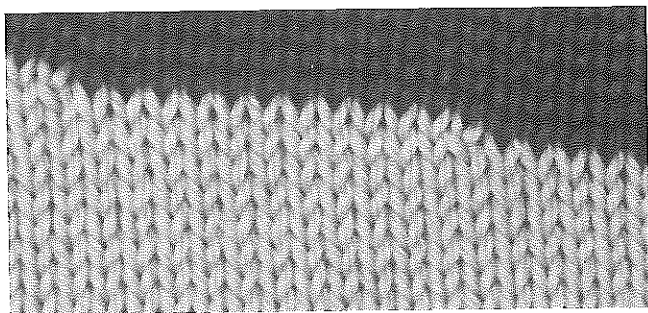

PARTIAL KNITTING is a practical method for shaping a gentle slope, such as a shoulder, bust darts and so on.

Partial knitting by decreasing stitches.

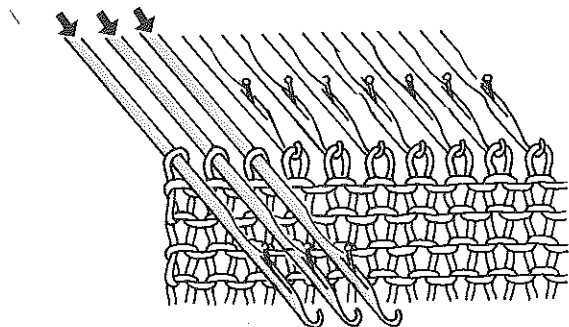

1. Push up the needles to be decreased to D position on the opposite side of the Carriage.

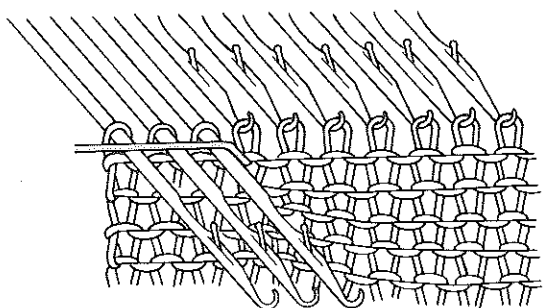

2. Knit 1 row.

The needles in B position knit the yarn. The needles in D position remain inactive and the yarn passes over them.

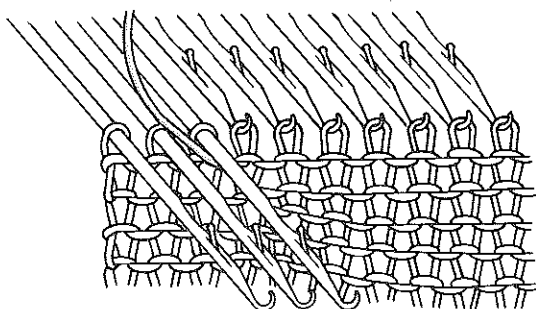

3. To prevent a hole from being formed in the fabric pass the yarn under the first inside needle in D position and over the other needles.

(If partial knitting is required on both sides, apply step 1 before knitting the next row.)

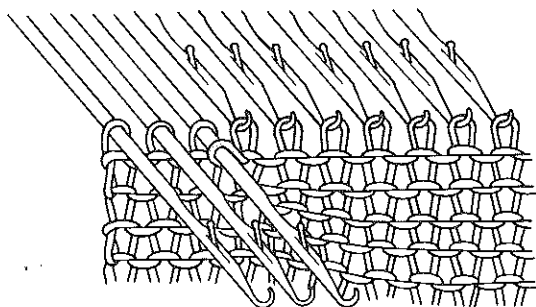

4. Knit 1 row by moving the Carriage back. This completes the first operation of partial knitting.
(If partial knitting is required on both sides, apply step 3.)

Repeat steps 1 – 3.

When the partial knitting is completed, push back the needles in D position to C position and continue to knit.

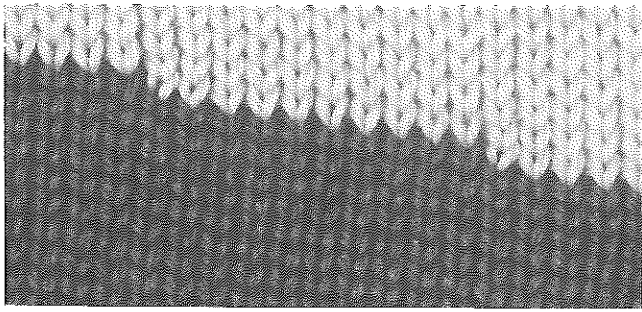

Partial knitting by increasing stitches

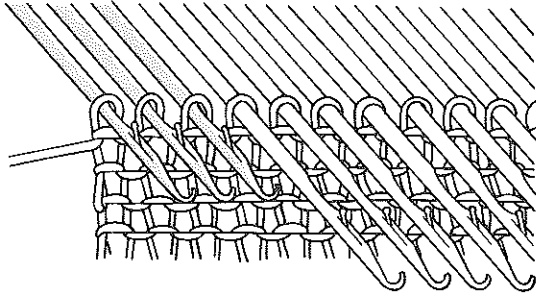

1. Push up all working needles to D position.
2. On the Carriage side, push the needles to be increased back to C position.

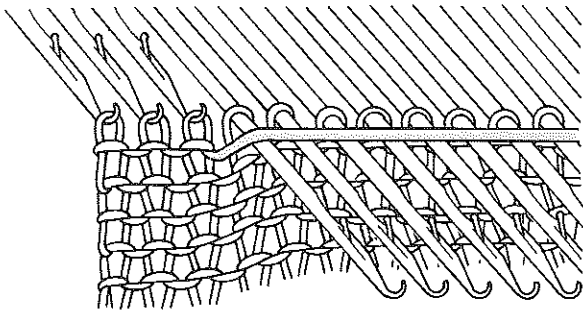

3. Knit 1 row.

The needles in C position knit the yarn. The needles in D position remain inactive and the yarn passes over them.

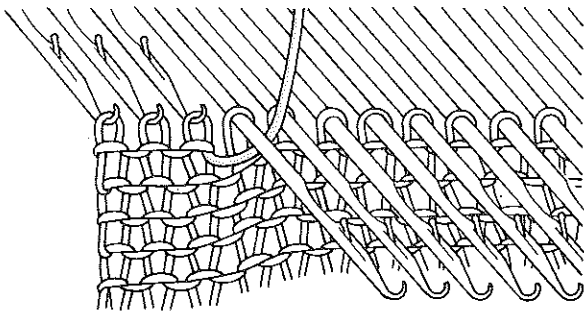

4. To prevent a hole from being formed in the fabric, pass the yarn under the first inside needle in D position and over the other needles.

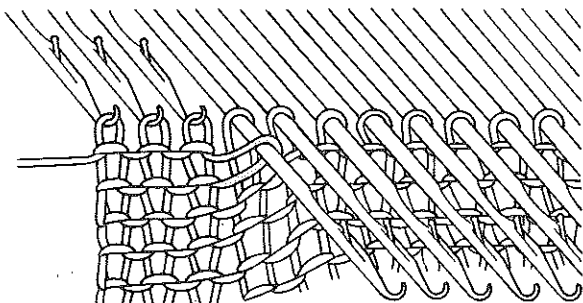

5. Knit 1 row by moving the Carriage back.

Repeat steps 2 – 5.

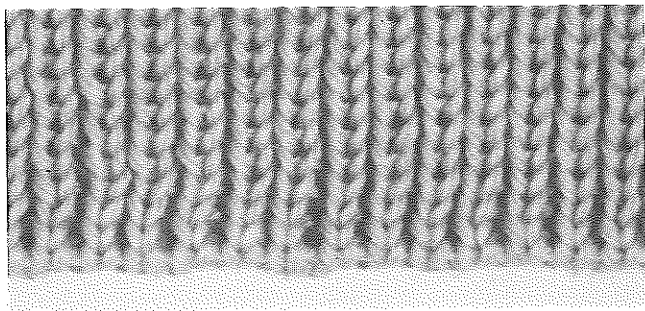

K1. P1. Rib

1. Push up the required number of needles to B position and push back every other needle to A position starting from the third needle from the left side.

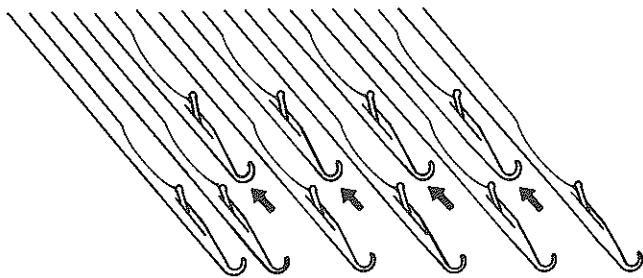

2. Cast-on and knit several rows of waste knitting. Hang Claw Weights on both sides of the fabric. Knit 1 row with Ravel Cord "A".

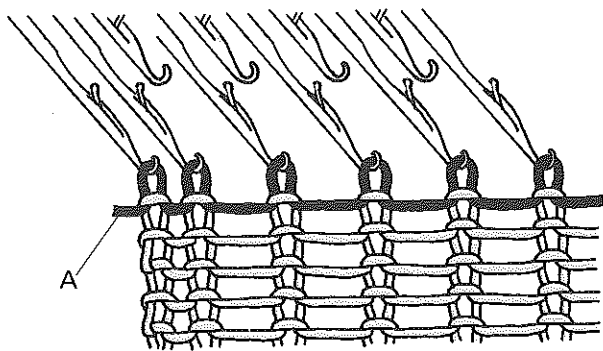

3. Thread the main yarn and knit 4 rows with Stitch Dial at 0.

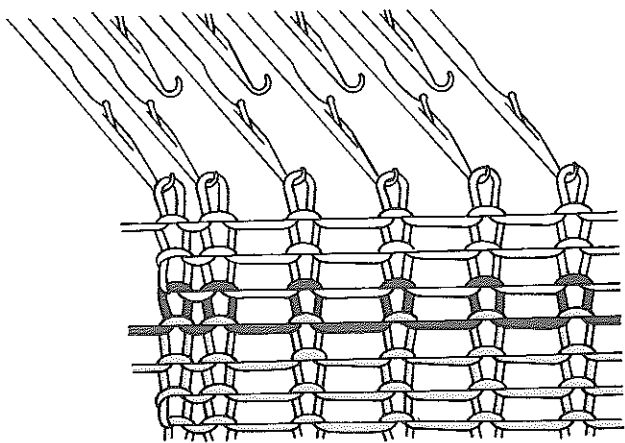

4. Insert the Transfer Tool into the left end sinker loop "B" on the first row of the main knitting.

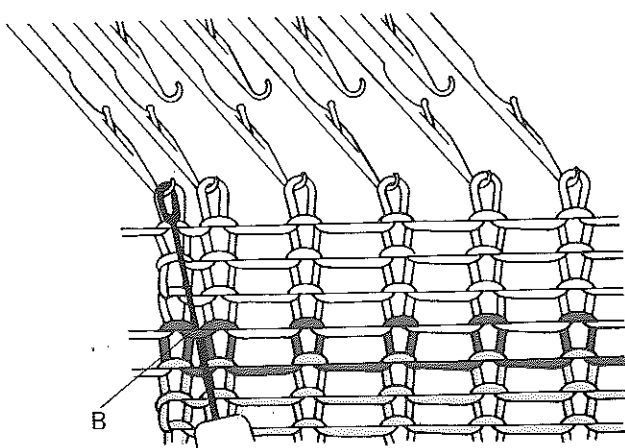

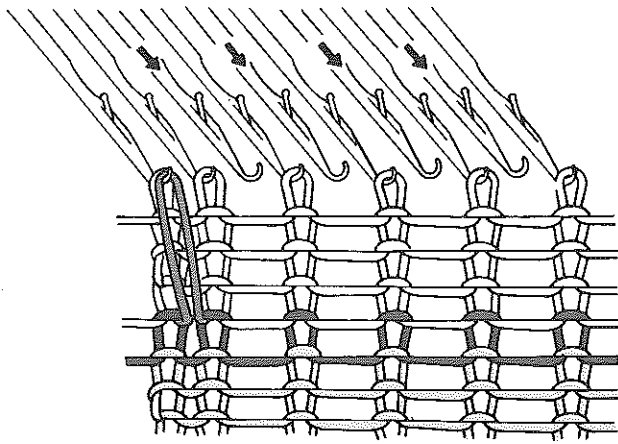

- Place the loop onto the end needle. Push those needles that were pushed back to A position in step 1, to B position.

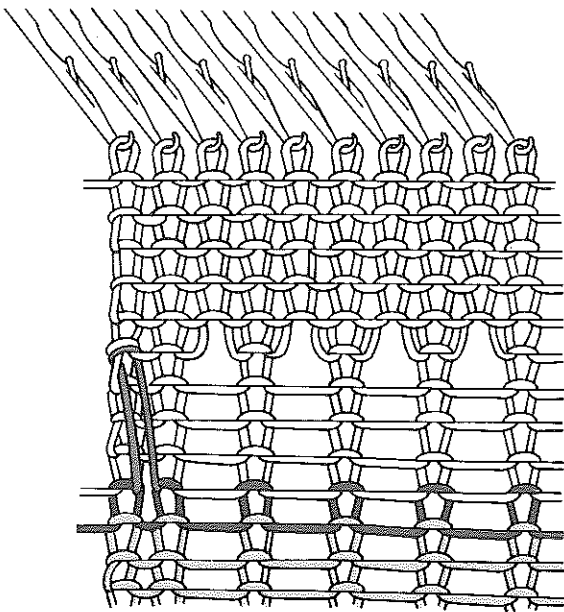

- Knit the length required for ribbing with the Stitch Dial 2 number lower than that for Stockinet knitting.

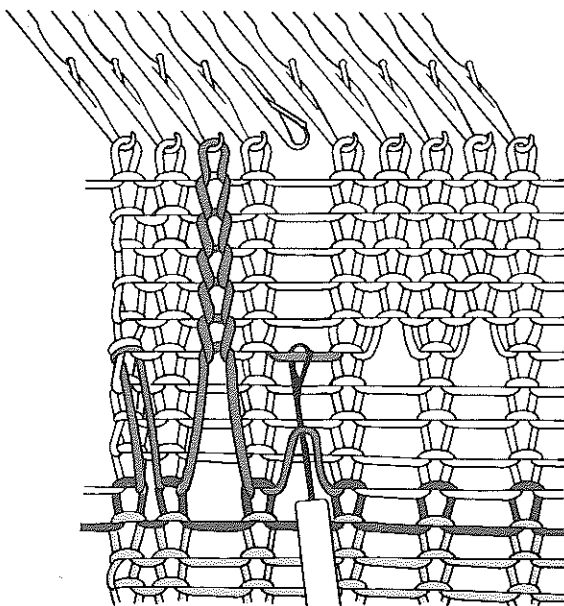

- Insert the Tappet Tool into the loop of the first row of main knitting and unravel the stitches as shown. Skip over the next 3 rows and hook the yarn on 5th row crossing above into the hook of the Tappet Tool.

8. Pull the Tappet Tool towards you. The first stitch will slip off of the Tappet Tool forming a new stitch.

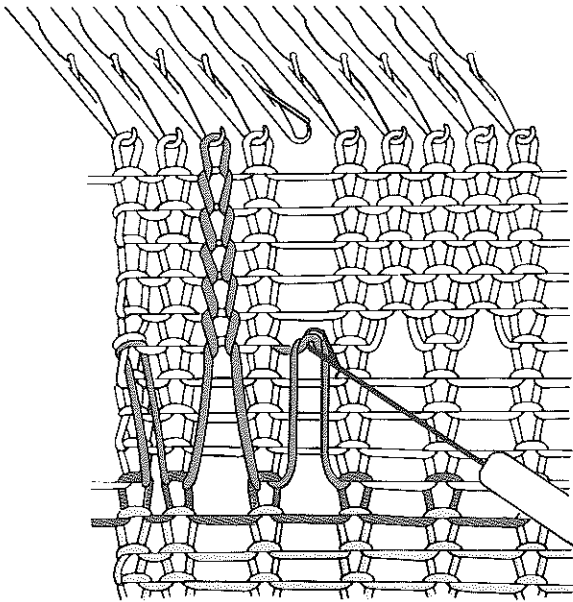

9. Hook the yarn on the next row crossing above and pull the Tappet Tool towards you.

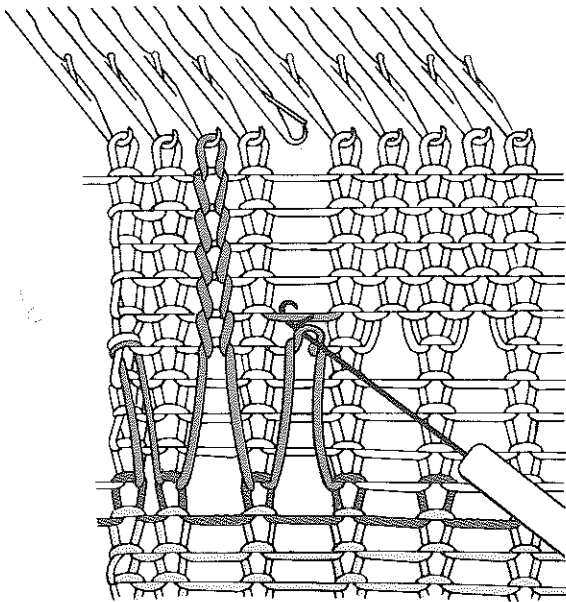

10. Repeat step 9 for every other stitch forming K1.P1. Rib.
Place the last stitch back onto its needle.

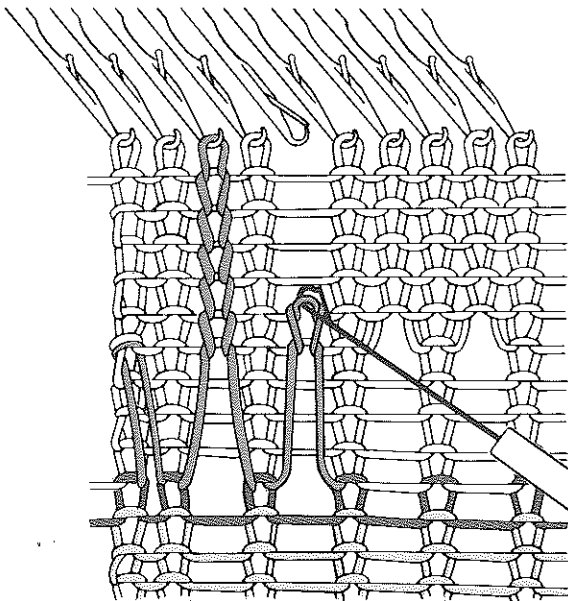

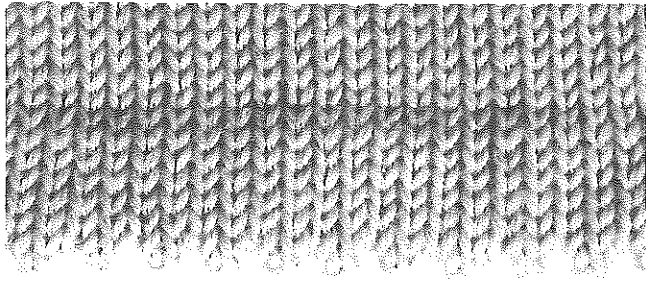

Picot Hem

1. Arrange required number of needles in B position and push back every other needles to A position.

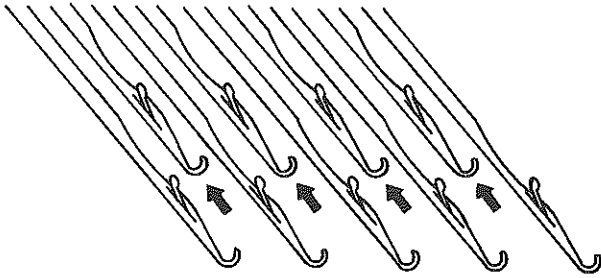

2. Cast-on and knit several rows of waste knitting, then knit 1 row with the Ravel Cord "A".

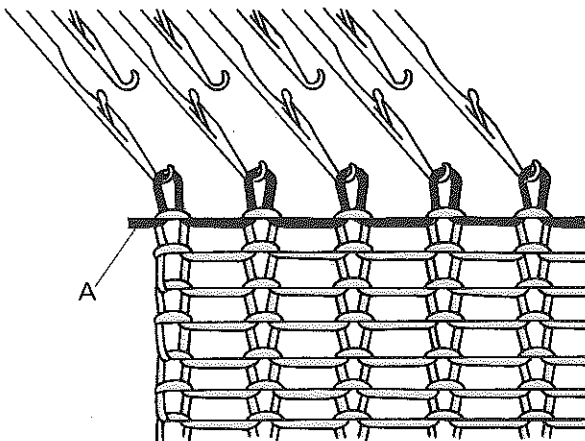

3. Set the Stitch Dial 2 full number lower and knit with the main yarn 2 rows fewer than required for the length of hem.

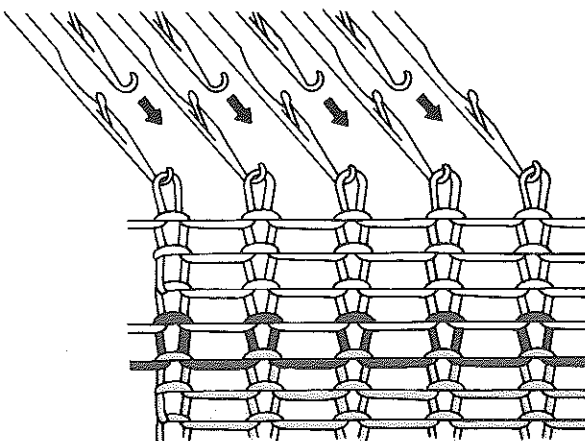

4. Push those needles that were pushed back to A position in step 1, to B position.

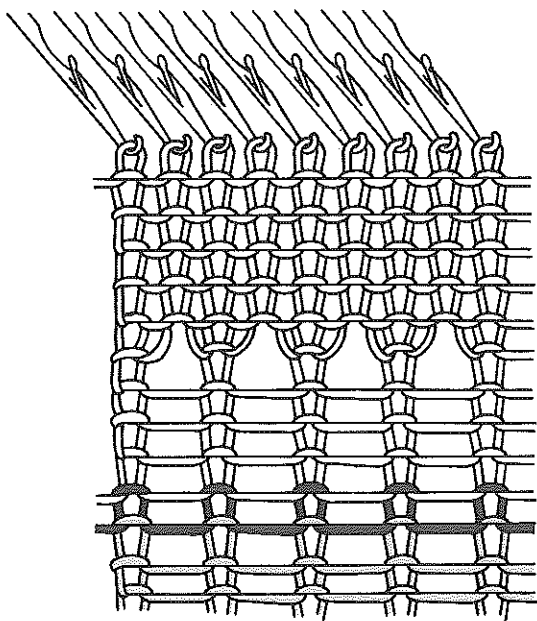

5. Reset the Stitch Dial to that originally used for stockinet knitting and knit required number of rows for the length of the hem.

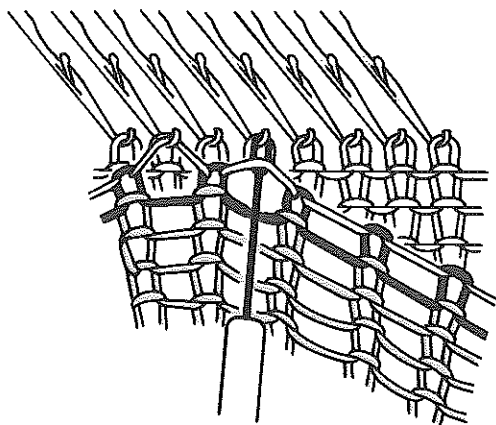

6. Place the sinker loops on the first row of the main knitting onto their corresponding needles. Pull out the Ravel Cord to remove the waste knitting.

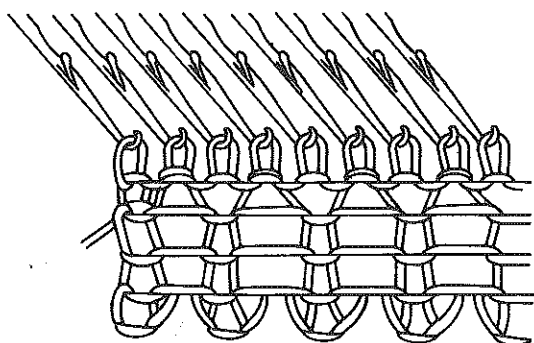

7. Set the Stitch Dial 1 full number higher than the number originally used. Push up the needles in B position to D position and knit 1 row.
8. Reset the Stitch Dial to the original number and continue to knit.

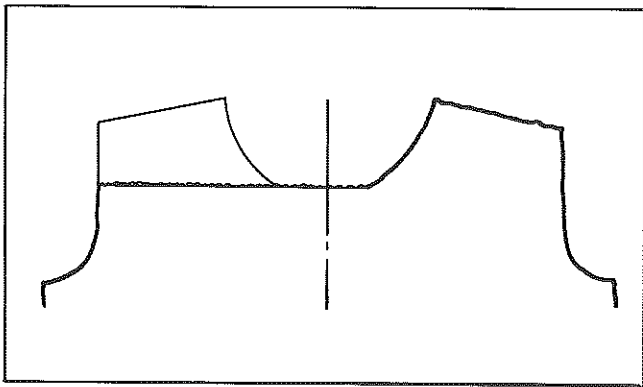

Holding stitches

If it is necessary to shape a garment partly, following methods are practical to hold the stitches for later shaping or work.

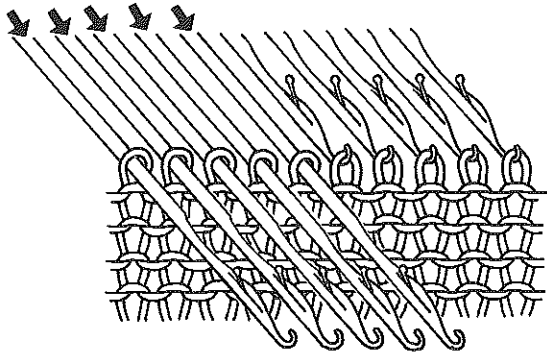

Needles in D position

1. Push up the needles for the section to be held, to D position.

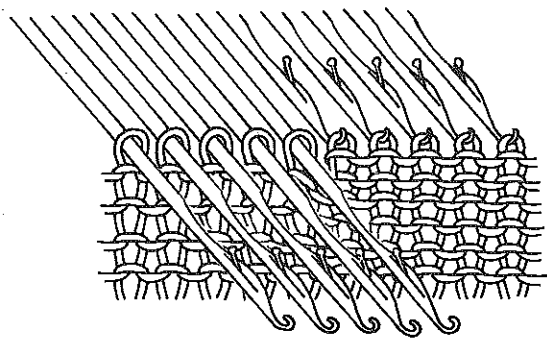

2. Set the Russel Lever to — position and continue to knit.

To knit again for the stitches which have been in holding position, push the needles back to C position, and continue to knit.

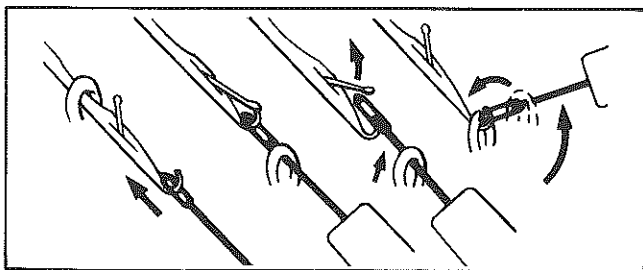

- * When pattern knitting is in progress, push the needles which have been in holding position back to B position using a Transfer Tool, replacing their stitches correctly back in their hooks.

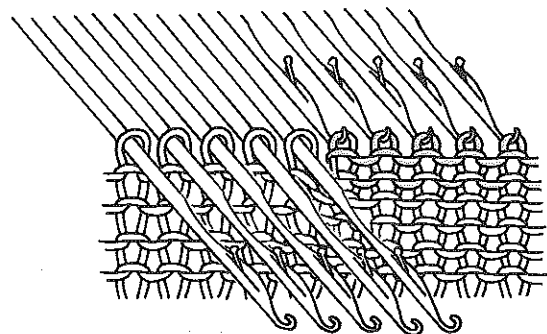

To release a part of fabric on waste knitting

Set the Cam Lever to "0" position and the Russel Levers to — position.

1. Leaving the needles for the stitches to be released on waste knitting in B position, push up the other needles to D position.

Set a contrast yarn for waste knitting into the Yarn Feeder and knit several rows.

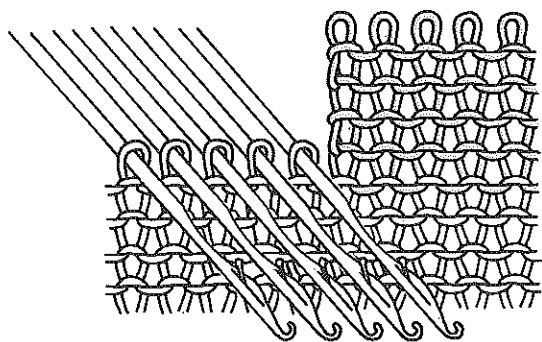

2. Remove the section on the waste knitting from the machine.

Reset the Carriage to original setting and continue to knit.

*To continue to knit in pattern stitch for the stitches held on the needles in D position, refer to the Pattern Chart, push back the selected needles to B position using a Transfer Tool.

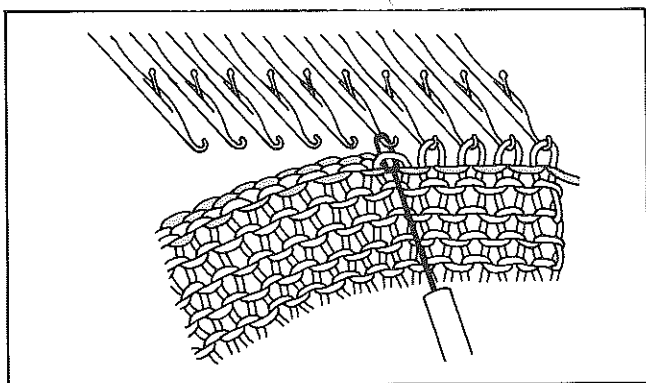

When re-knitting the stitches held on waste knitting, pick up the stitches on the 1st row of the main knitting and place them onto the corresponding needles.

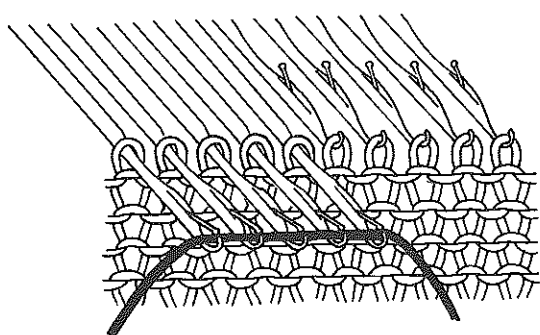

To hold the stitches on the needles in A position

1. Push up the needles for the section to be held, to D position, and lay the Ravel Cord across the hooks.

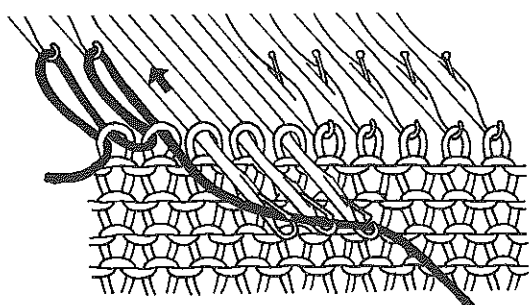

2. Starting from the end needle, knit the Ravel Cord needle by needle and back to A position by hand.

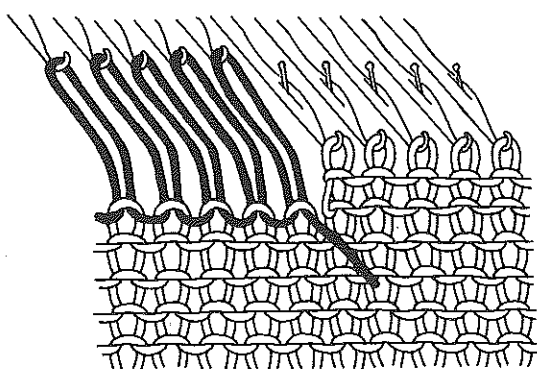

3. Continue to knit.

Before knitting each row, make sure that the needles are correctly placed in A position. (If not, push them back into A position properly.)

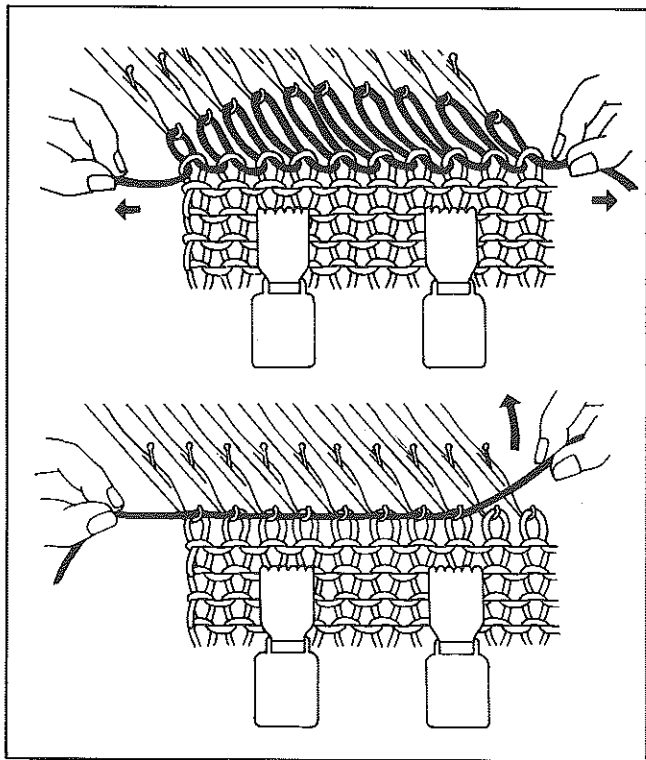

To bring the needles back into B position, pull both ends of the Ravel Cord by hands.

Note: Before pulling the Ravel Cord, hang the Claw Weights on the fabric.

When the needles are brought to B position, hold the left ends of the Ravel Cord and pull the other end in an upward motion.

The stitches are replaced in the hooks.

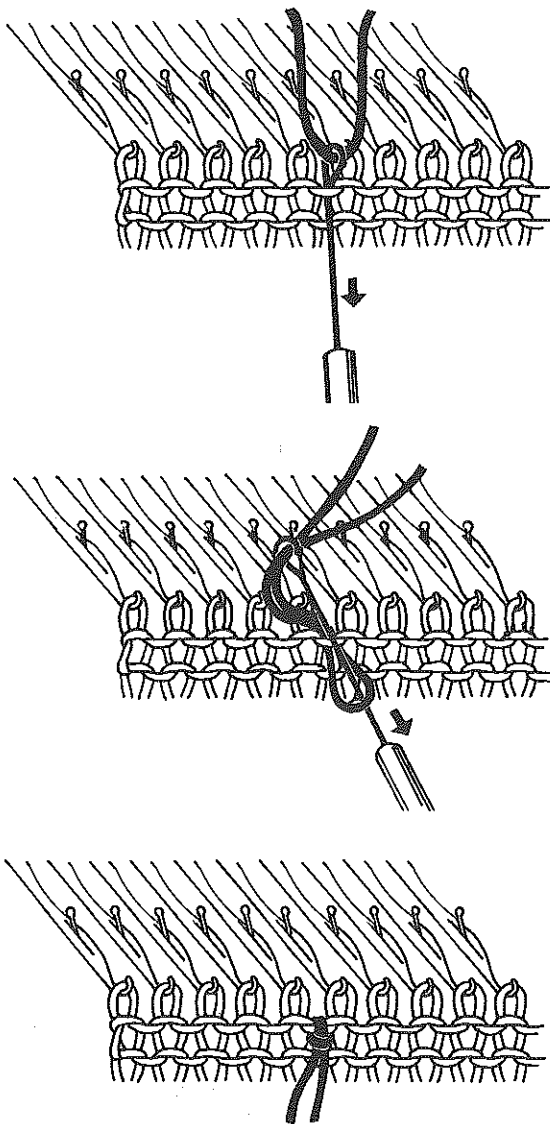

Put the yarn mark

Insert the Tappet Tool into the sinker loop that is to be marked and by taking a piece of waste yarn, form a loop on the Tappet Tool. Pull the Tappet Tool through the sinker loop.

Catch both ends of the waste yarn and pull out the Tappet Tool through the loop.

Buttonhole

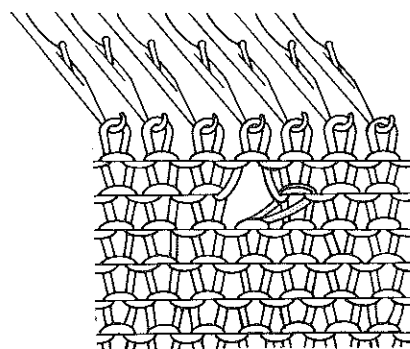
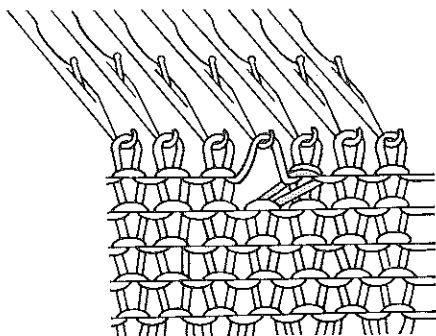
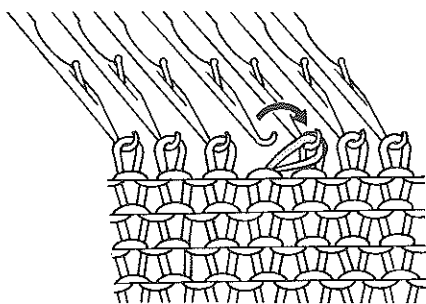

1. Place 1 stitch onto its adjacent stitch.

2. Knit 1 row so that a hole is formed.

3. Continue to knit.

K1.P1. Rib

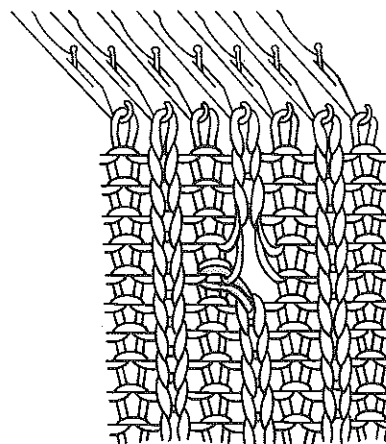
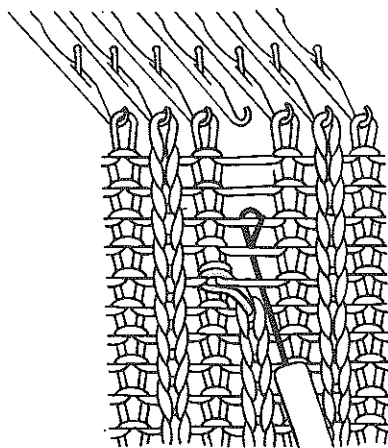
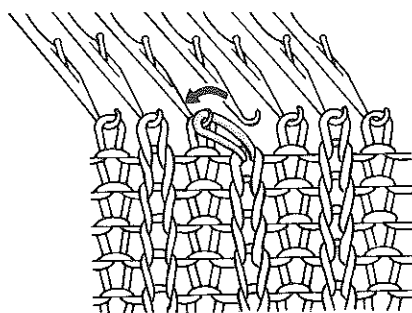

1. Place 1 stitch onto its adjacent stitch.

2. With the empty needle in B position, continue to knit. Insert the Tappet Tool behind the first two rows and hook the third row.

3. Form new stitches as shown.

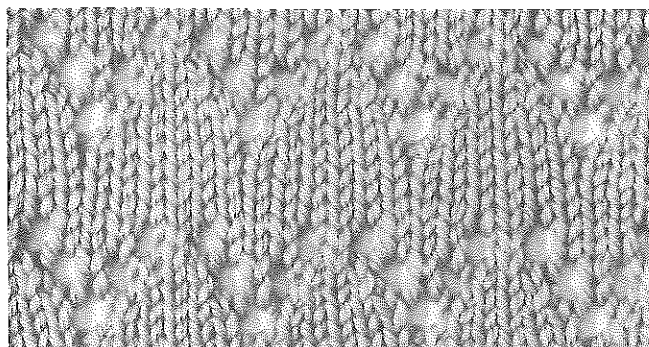

Openwork

* This pattern is worked by transferring the stitches using a Transfer Tool.

1. Knit two rows in stockinet. Put the eye of a Transfer Tool in the hook of the needle making a hole.
2. Push the needle back to A position. The stitch will be transferred onto the Transfer Tool.
3. Put the eye of the Transfer Tool onto the adjacent needle and transfer the stitch.

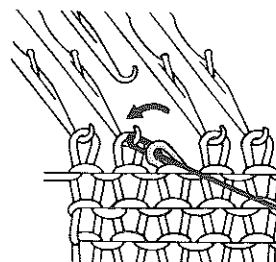
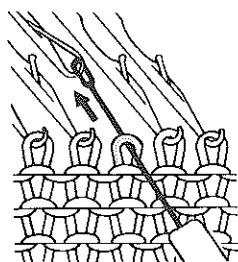
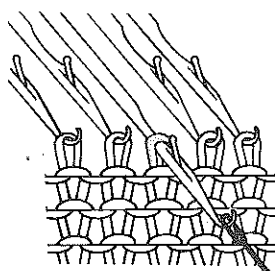

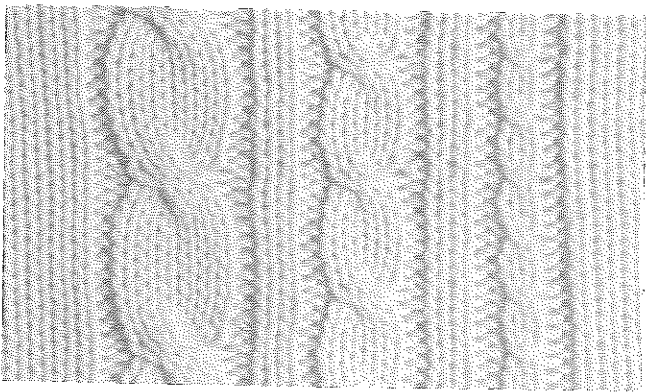

Cable Pattern

Cable pattern is formed by crossing a group of stitches over another group of stitches using two Transfer Tools.

Try a cable of 6 knit stitches.

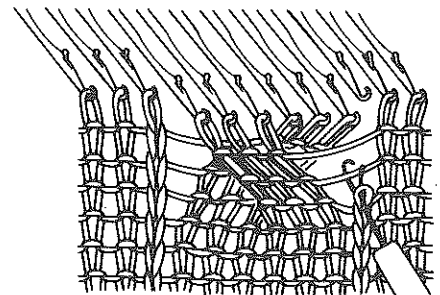
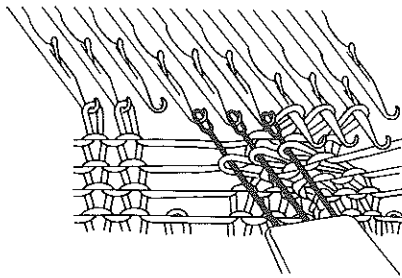
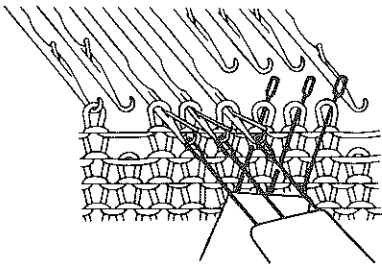

1. Drop one stitch at each outside of those 6 stitches. Using a 3-prong Transfer Tool, pick up 3 stitches next to the first 3 stitches as shown.
2. Cross those two Transfer Tools and replace each three stitches to new needles.
3. Reform the dropped stitches at both side of the crossed stitches using the Tappet Tool, and replace them onto the original needle.
4. Before knitting, push those 6 needles into C position, and continue to knit to the next position for crossing the stitches.
5. Repeat the above procedure.

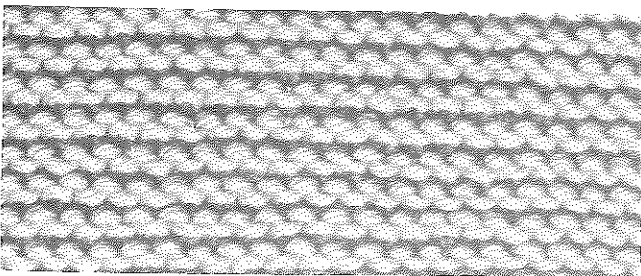

Garter Stitch

Garter stitch is used for laps, collars, borders, etc.

Knit the pattern purling the stitches every other row.

1. Set the Stitch Dial 2 number lower than that for Stockinet knitting. Knit 2 rows in stockinet.

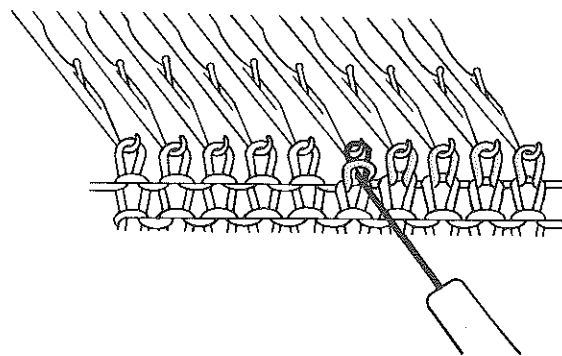
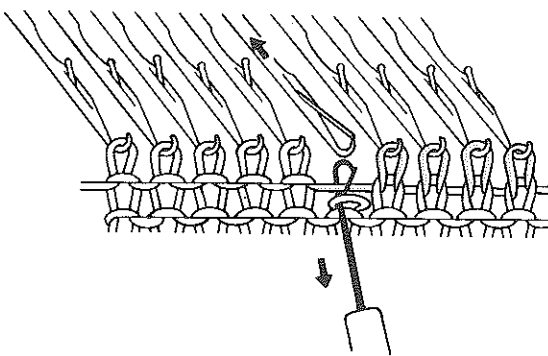

2. Insert the Tappet Tool into the stitch below that which is hooked on the needle, and push up the needle to D position.
3. Push the needle back to B position and pull the Tappet Tool in the arrowed direction forming a purl stitch.
4. Place the newly formed stitch back onto the needle. Repeat steps 2 – 4 for all stitches on the row.
5. Knit 2 rows of stockinet and re-form the stitches on the second row in the same manner as done in steps 2 – 4.

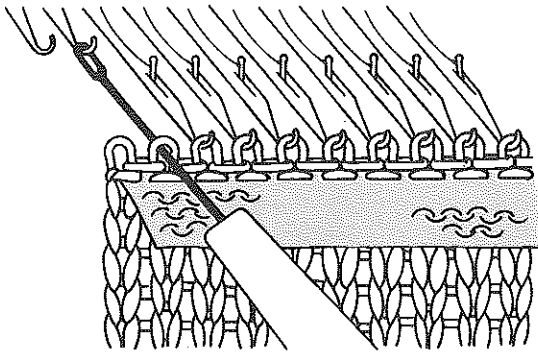

Joining on the Machine

Stitch to Stitch

This is used for joining shoulders, etc.

1. With the right side of the first fabric to be joined facing you, pick up the stitches on the last row of the main knitting and place them onto the needles.

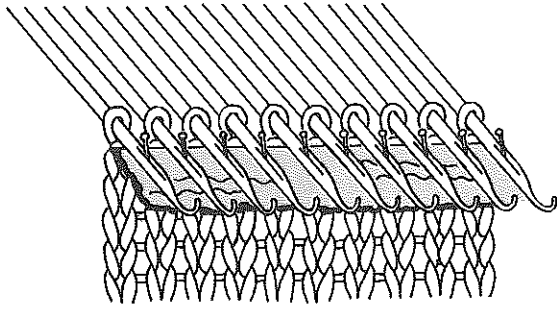

2. Push the needles to D position and bring the stitches of the fabric behind the latches.

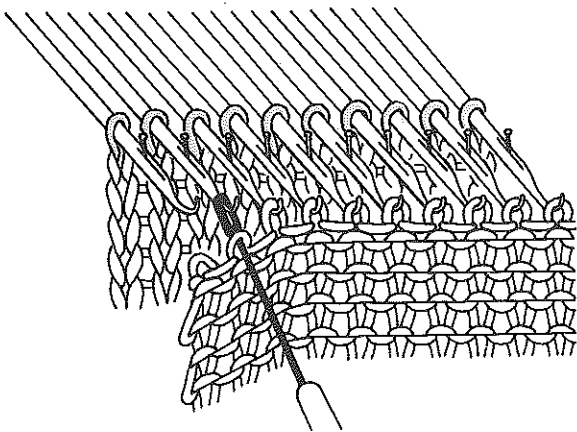

3. Place the stitches on the first row of the main knitting of the second fabric onto the needles with its wrong side facing you.

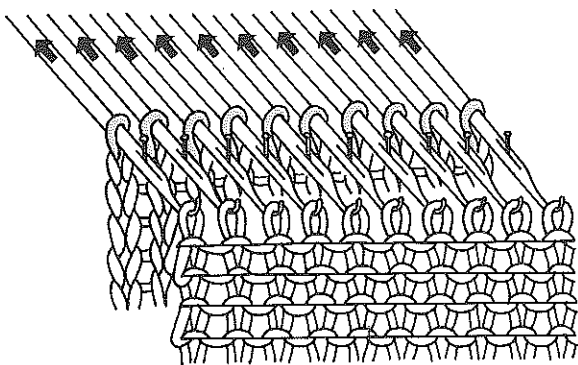

4. Unravel the waste knitting of both fabrics.

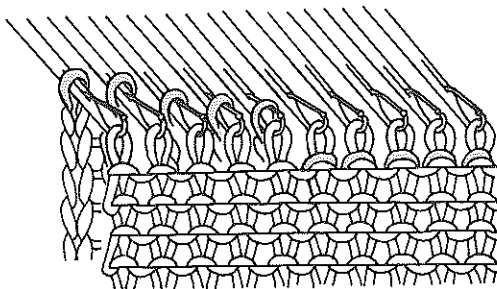

5. Push the needles towards B position. The rear stitches will slip off of the needles and interloop with the front stitches.

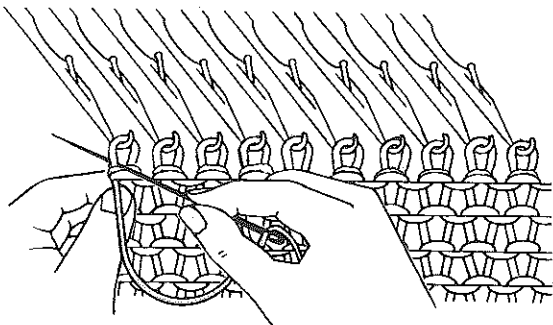
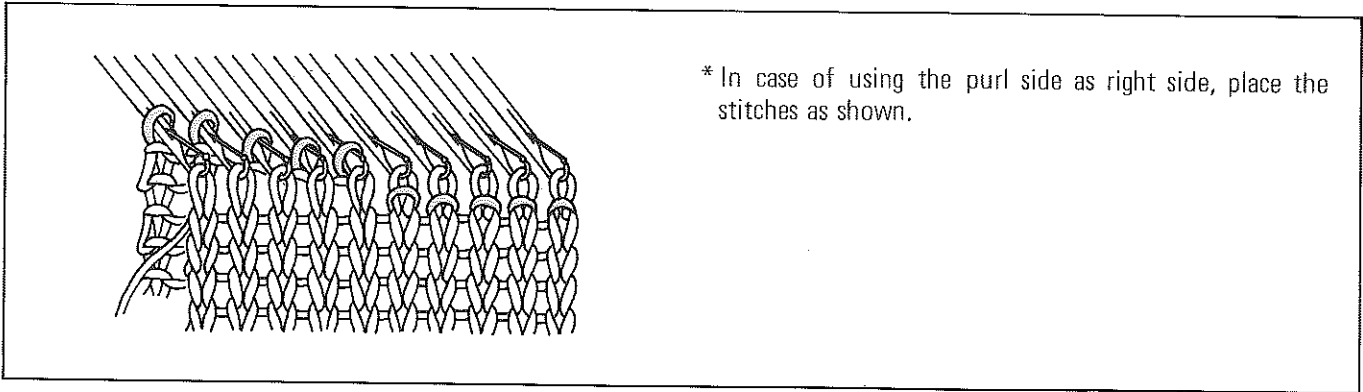

6. Cast off the stitches by using the Back Stitch Method.
- (1) Thread the Tapestry Needle and insert it into the first stitch and pull the yarn.

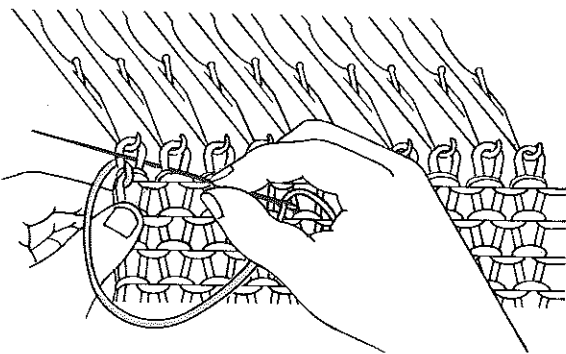

- (2) Insert the Tapestry Needle through the second stitch and pull out from the first stitch.

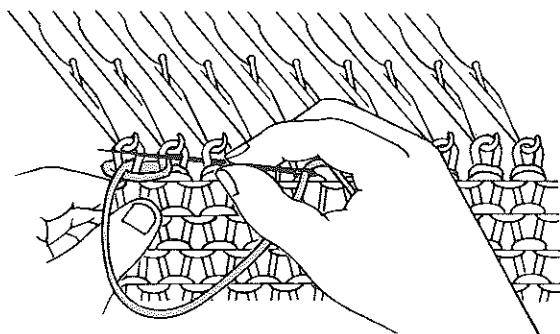

- (3) Insert the Tapestry Needle through the third stitch and pull out from the second stitch.

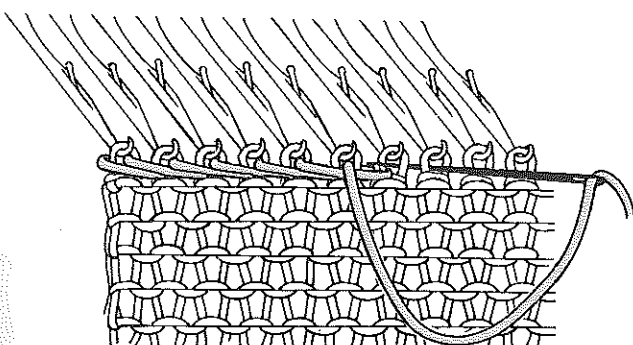

- (4) Repeat steps (2) – (3).
Close the last stitch by inserting the yarn and guiding it out the stitch.

Open Stitch to Side Edge

This is used for joining the border to the front open edge of a cardigan, etc.

1. With the knit side of the first fabric facing you pick up the stitches on the side edge, omitting a stitch at appropriate intervals, and place them onto the needles.

2. Push up the needles to D position. With the purl side of the second fabric facing you, pick up the stitches on the last row of the main knitting, and place them onto the same needles.

3. Push back the needles to B position.

4. The stitches behind the latches will slip off of the needles. Unravel the waste knitting.

5. Cast off the stitches using the Back Stitch method. (Refer to Page 56, step 6.)

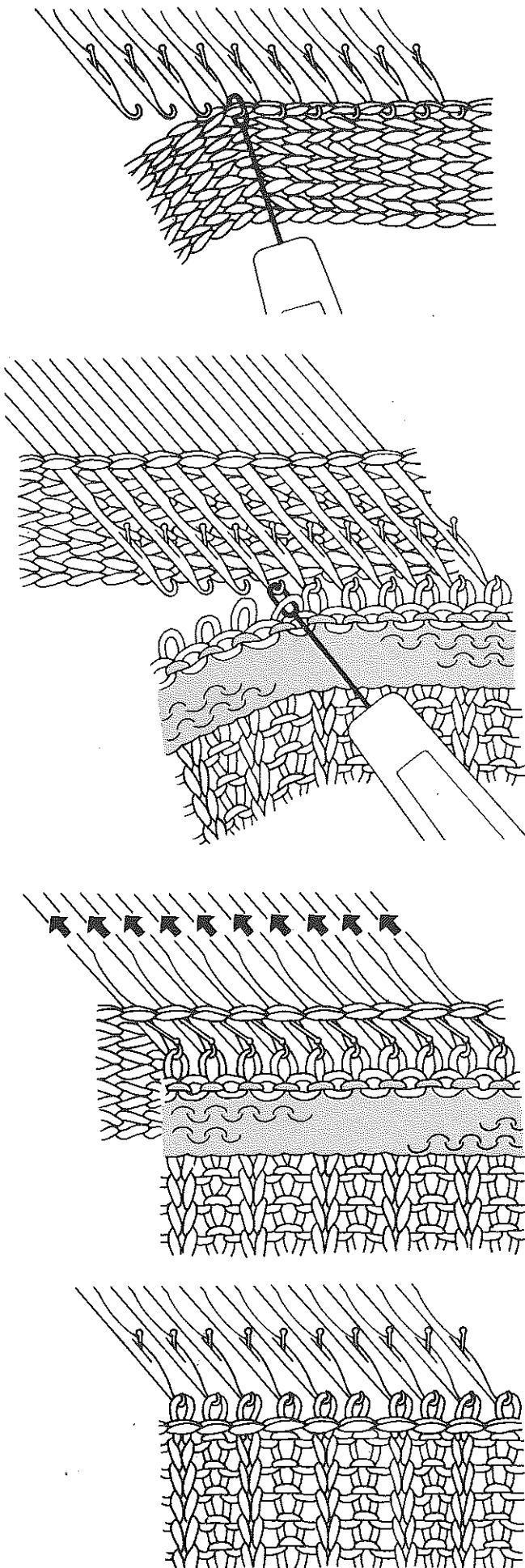

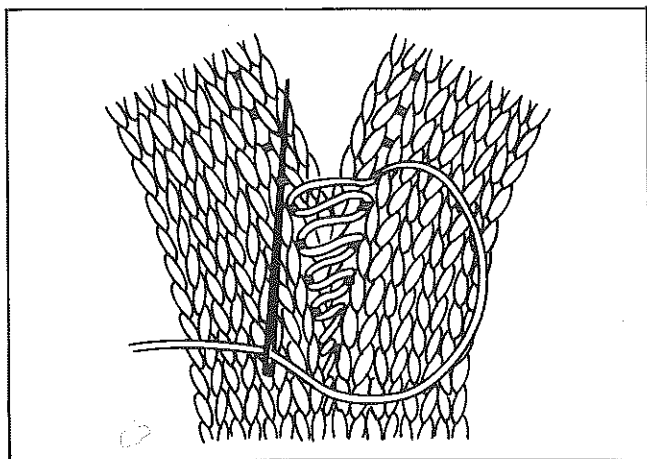

Blind Stitch

This is used for joining side seams.
It is recommended to use medium type yarn.

Knit side to be worn.

With the right sides facing you, pick up each sinker loop between the last 2 stitches from the side edge.
Repeat this manner alternately for every row.

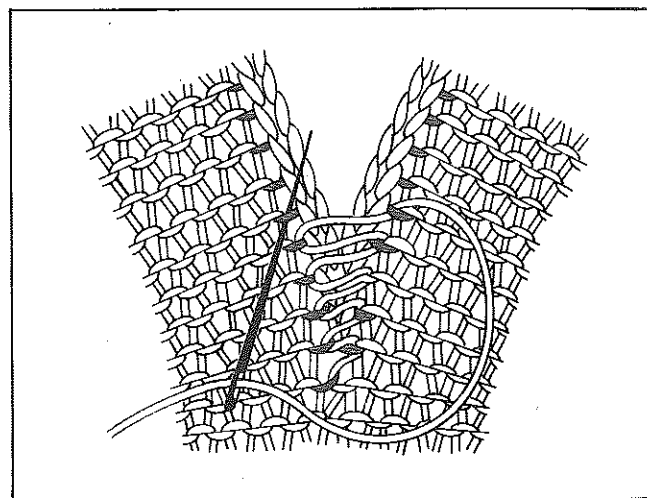

Purl side to be worn.

With the purl sides facing you, pick up each sinker loop between the last 2 stitches from the side edge.
Repeat this manner alternately, every row.

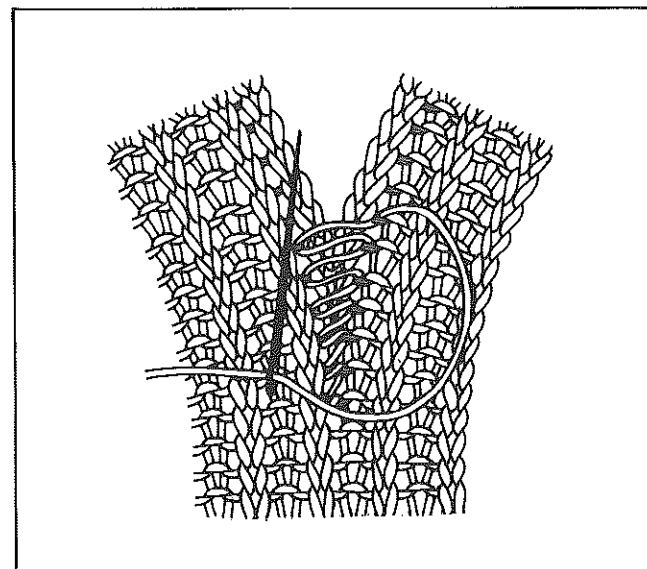

K1.P1. Rib

With the side to be used as the right side facing you, pick up the sinker loops between the last 2 stitches from the side edge alternately for every row.

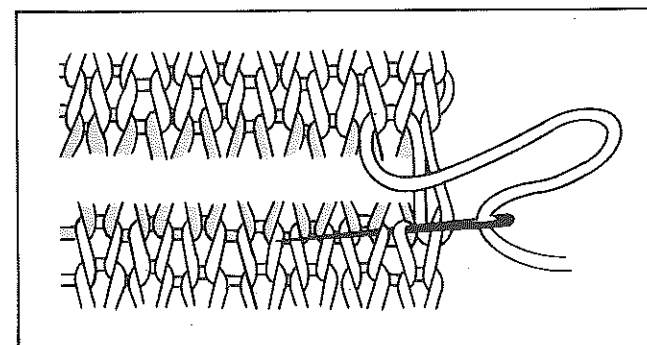

Grafting

This is used for joining two open rows, where ridges formed by seaming should be soft to the touch.

Align both fabrics as shown and thread the knitting yarn through the stitches with the Tapestry Needle.

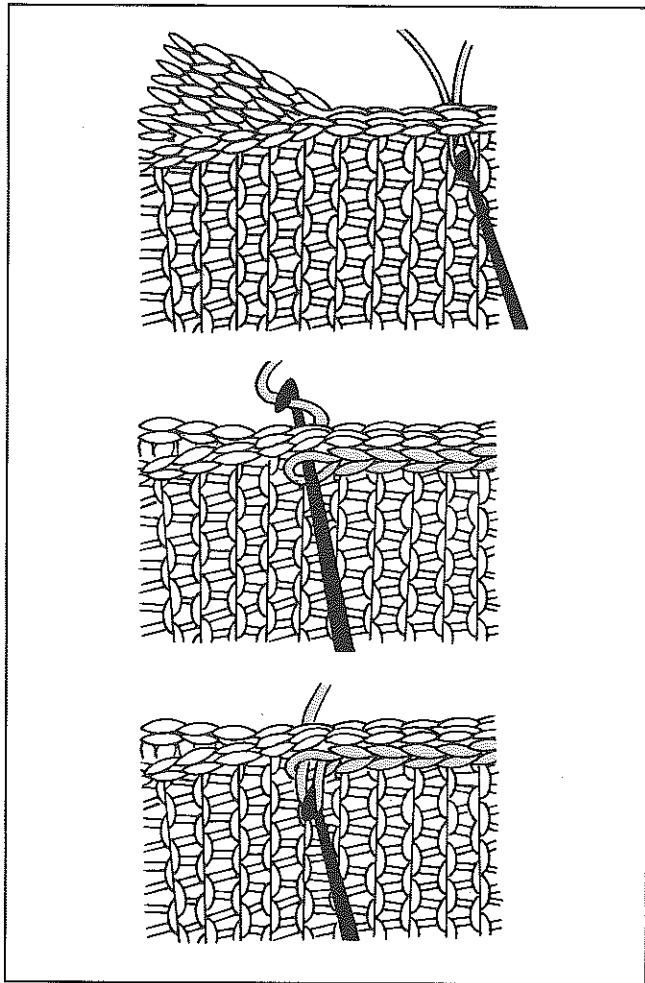

Slip Stitch

Place the fabric to be joined with the right side.

This is used for setting in the sleeves or joining side seams.

1. Place the fabric to be joined with the right sides facing each other. Insert the Crochet Hook into each sinker loop between the last 2 stitches from the side edge and catch the yarn, pull back it.

2. Insert the Crochet Hook into the next loop and catch the yarn.

3. Pull back the Crochet Hook.

Repeat steps 2 – 3.

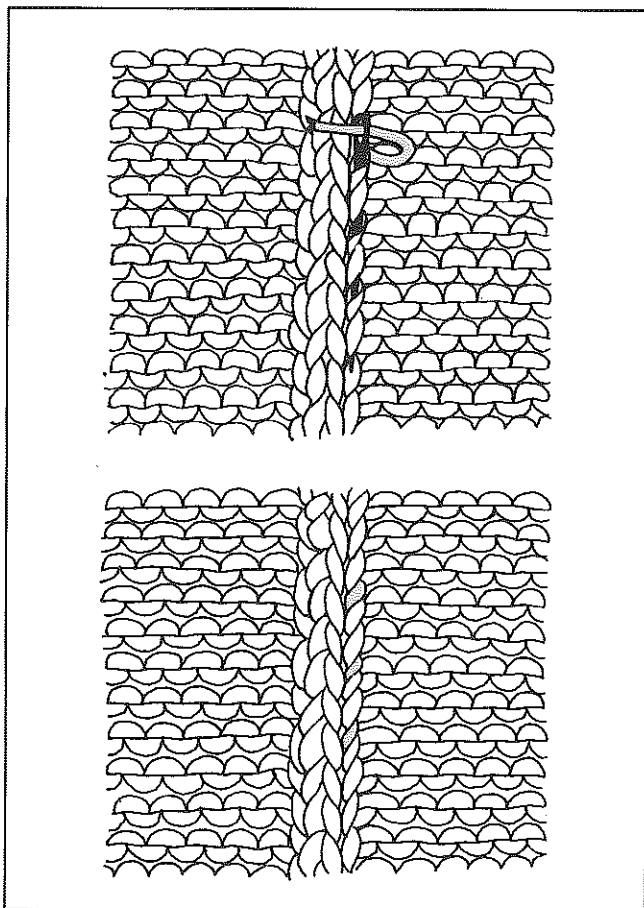

Sew in Yarn Ends

Thrust the tapestry Needle into the seamed ridge and thread the yarn end through the eyelet of the Tapestry Needle, and sew in the yarn end into the ridge.

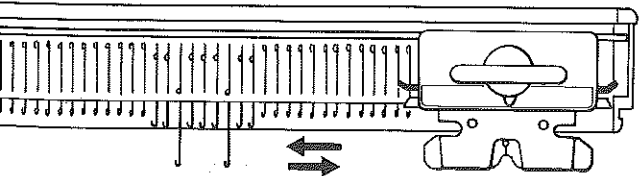
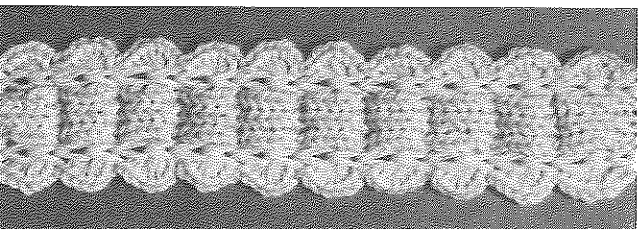
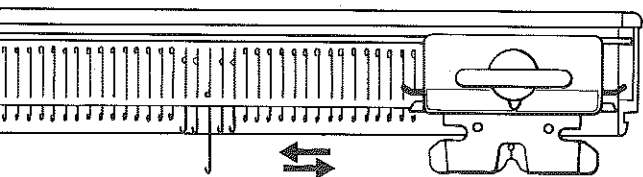
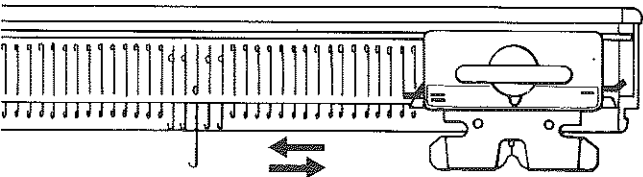
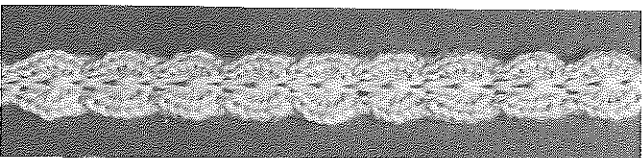
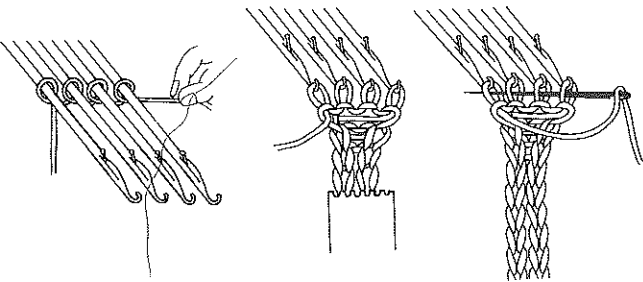
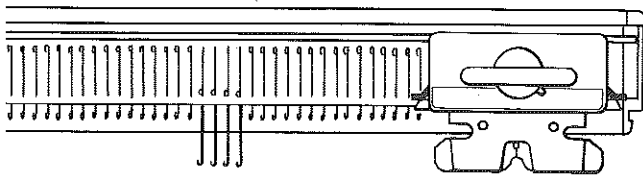
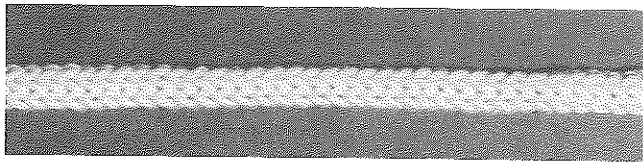

Cord knitting

1. According to the thickness of the cord you desire, push 3 – 5 needles into D position.
2. Set the Carriage as follows:—
 Cam Lever..... S
 Russel Levers = (both)
 Cast-on the stitch by winding method as illustrated.
3. Knit 2 rows.
 (The Carriage knit the first row and pass the second row without knitting.)
4. Push up the needles to D position passing above the floating yarn.
 Repeat steps 3 – 4.
 After knitting several rows, hang a Claw Weights on the cord and continue knitting until the desired length has been knitted.
5. Cut the yarn leaving 10cm. and cast off the stitches with a Tapestry needle as shown.

Braid

These braids are knitted in tuck stitch.
 Use medium thick yarn.

Using 5 stitches

1. Cast-on 5 stitches and knit 5 rows of Stockinet leaving the Carriage at right.
 Hang a Claw Weight and attach the Tuck Brushes.
2. Set the Carriage as follows:—
 Cam Lever..... 0
 Russel Levers — (both)
3. Push up the centre of 5 needles to D position and knit 6 rows.
4. Set the left Russel Lever at =, knit 2 rows.
5. Reset the left Russel Lever to —.

Repeat steps 3 – 5.

Using 9 stitches

Cast-on 9 stitches and knit in the same manner as instructed in using 5 stitches. But push up third needles from both sides and knit 6 or 8 rows in step 3.

HELPFUL HINTS

To replace a dropped stitch

1. Insert a prong of Transfer Tool into the dropped stitch.

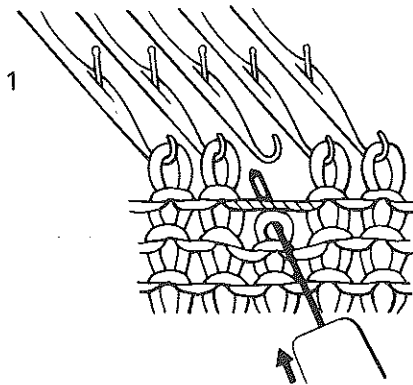

2. Replace the stitch onto the empty needle together with the bar above the stitch.

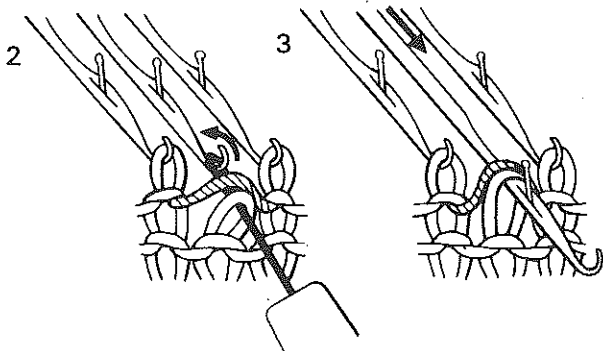

3. Push forward the needle till both stitches move behind the latch.

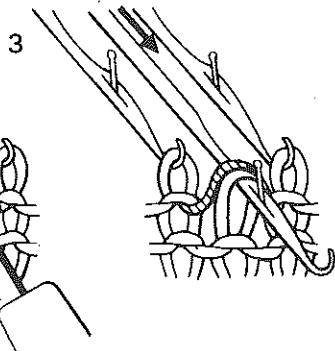

4. Lift up the bar using the Transfer Tool and bring it over the latch.

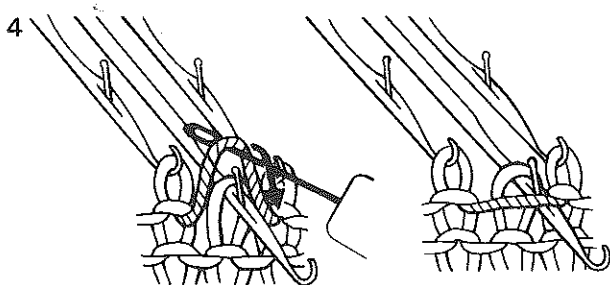

5. Push back the needle till the stitch behind the latch slips off of the needle.

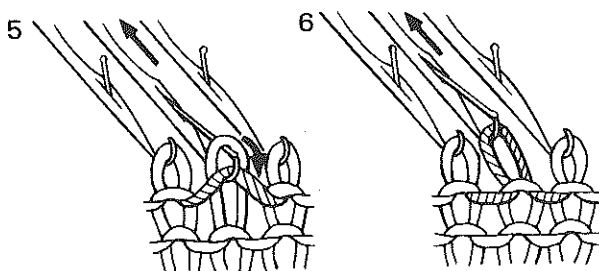

6. Push the needles toward A position to correct the size of stitch.

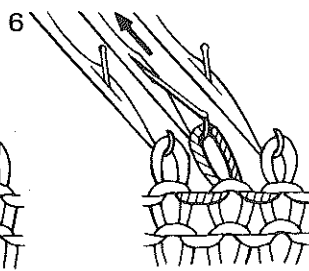

7. Align the needle correctly in B position.

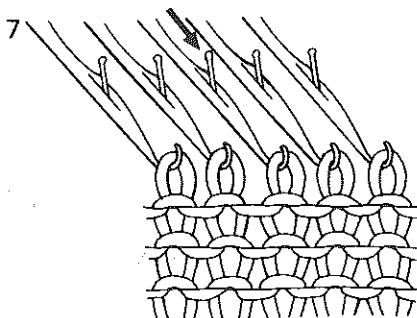

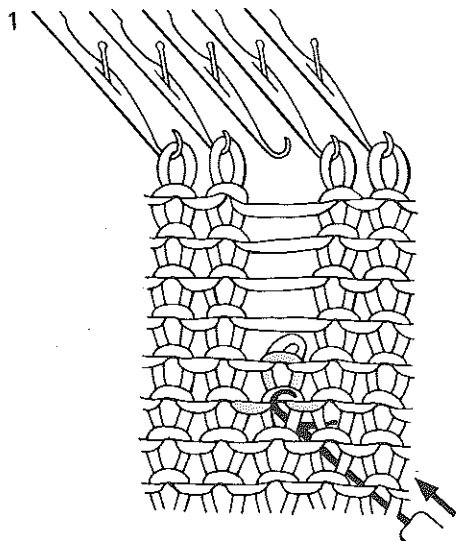

If a dropped stitch has run down for several rows...

1. Insert the Tappet Tool into the stitch at a few rows down the dropped stitch from the rear side.

Let the stitch run down to the Tappet Tool.

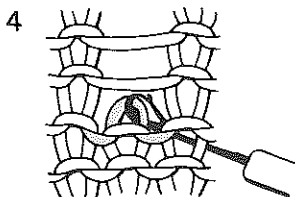
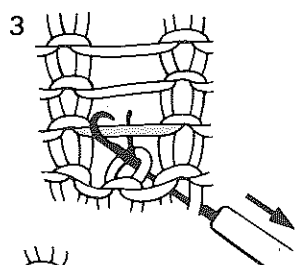
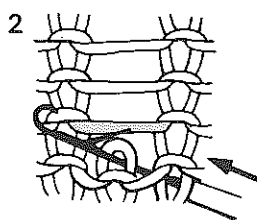

2. Push forward the Tool till the stitch moves over the latch of the Tool.

3. Pulling the Tool backward, catch the bar crossing above.

4. The stitch behind the latch slips off of the Tool and interloop with the bar in the hook.

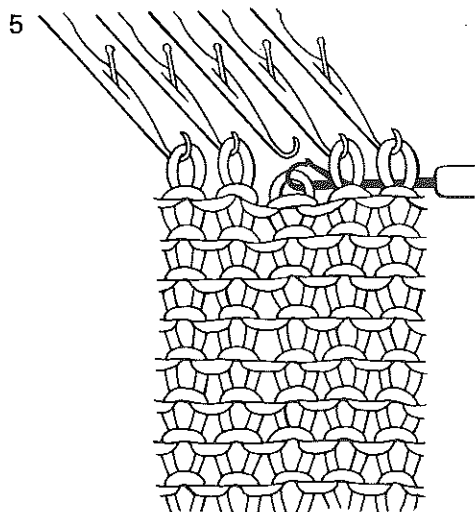

5. Repeat the above steps up to the top stitch.

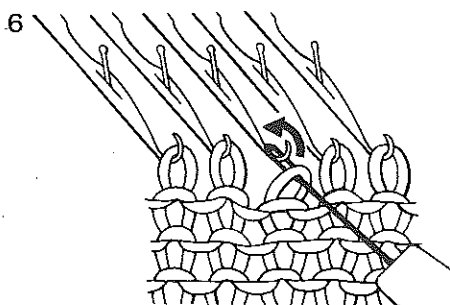

6. Take the top stitch onto the Transfer Tool on the front side, and fill the empty needle with it.

If one or more stitches have dropped or when in pattern knitting, it would be rather easier to unravel the rows than to repair the stitches.

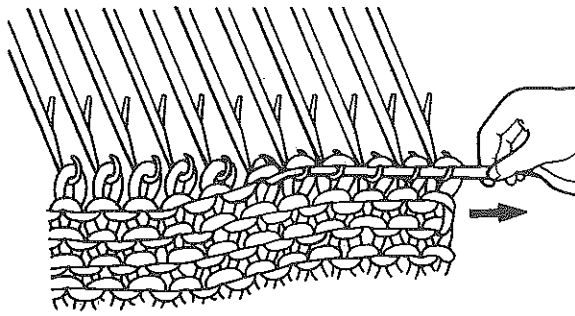

To unravel knitted fabric on the machine

1. Holding the fabric downwards, pull the yarn out, and the row gets tight.

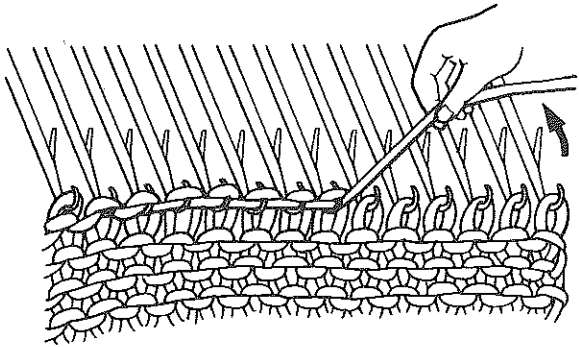

2. Lift the yarn upwards and very slightly backwards, the stitches of the previous row will slide off the yarn and back into the needle hook.

If the fabric has been shaped in decrease or partial knitting.

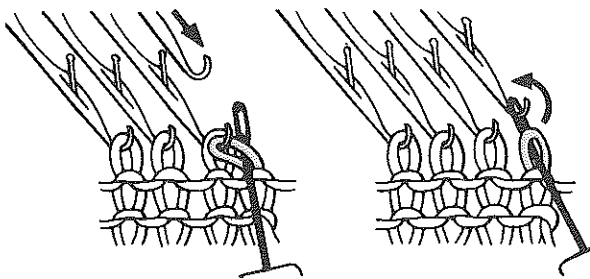

Fabric with decreased edge.

On the row of decrease, the end needle has two stitches, place one stitch back to its original needle.

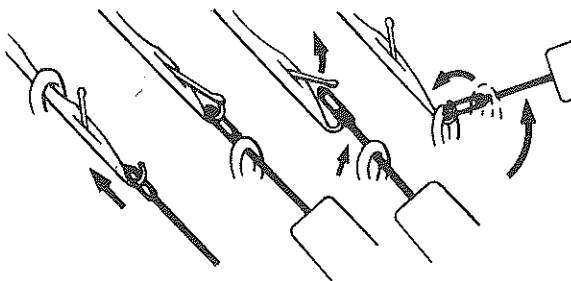

In the course of partial knitting.

Push the needles, pushed out to D position in the course of partial knitting, back to B position using a Transfer Tool.

3. To continue knitting, pull the unravelled yarn back towards the yarn ball at the back of the Tension Rod, pass the Carriage over to the side of the yarn end, adjust the Row Counter, and replace the yarn in the Yarn Feeder.

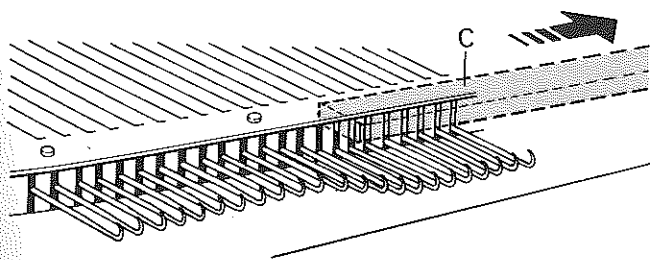
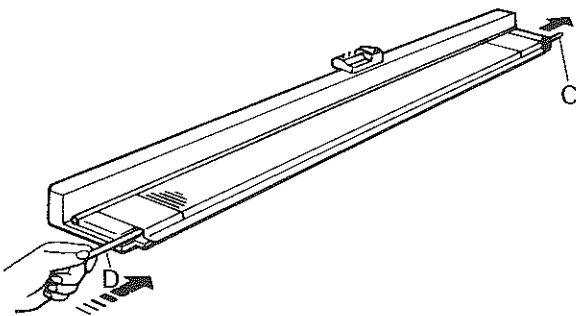
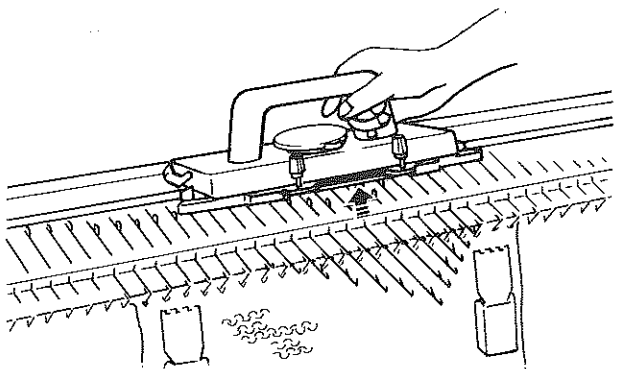
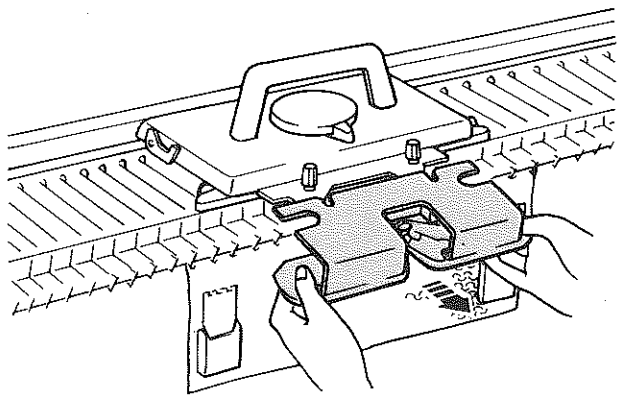

If the Carriage has jammed...

In the middle of the row, do not push the Carriage by force, proceed as follows to release the Carriage from jamming.

1. Lay down the RC Lever.
2. Remove the yarn from the Yarn Feeder.
3. Loosen both Arm Nuts and remove the Arm from the Carriage.
4. Move the Carriage in its proceeding direction while lifting the front of the Carriage until it clears off the working needles.
5. Pick up dropped stitch, if any. (Refer to page 61 – 62 for correcting stitches.)
Push back the needles in C or D position to B position replacing the stitches into its needle hooks using Transfer Tool.
Unravel the incomplete row, and pass the Carriage to the side of the yarn end. (Refer to page 63 for unravelling the row.)
6. Attach the Arm and Tuck Brushes if it has been in use. Readjust the Row Counter and raise the RC Lever.
7. Replace the yarn into the Yarn Feeder and continue to knit.

To replace a damaged needle

A needle with a damaged latch or a bent needle will cause incorrect knitting or dropped stitches.

The needle latch "A" must move smoothly and lie flat over the hook "B".

1. At each side of the needle Bed, you can see the Needle Retainer "C".

If the damaged needle is at the left half of Needle Bed, place the Carriage at right side and using a pencil "D" push the Needle Retainer at its left plastic end.

The Needle Retainer is then pushed out of the Needle Bed at the right end and you can pull it out of Needle Bed until the damaged needle lies free.

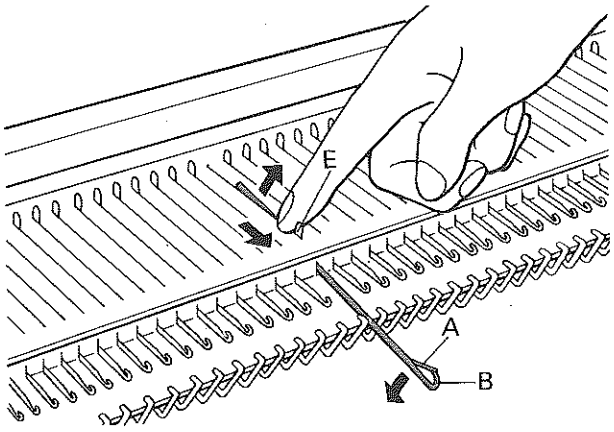

2. Push the damaged needle to D position by pressing its butt "E". Close the latch "A" and press the hook "B" down. The shank "F" will then come out of the needle groove.

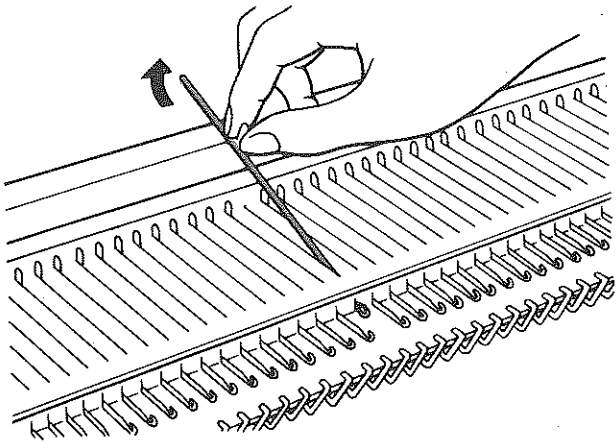

3. Lift up the needle by holding the shank and pull it to remove from the Needle Bed.

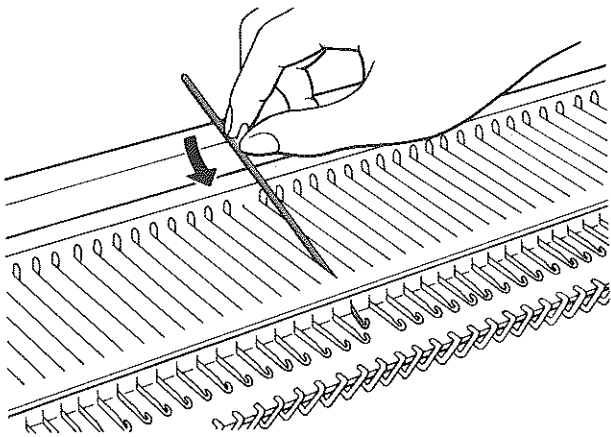

4. To replace a new needle, open its latch and slide it into Needle Bed slit until the hook comes out of the front opening of the Needle Bed.

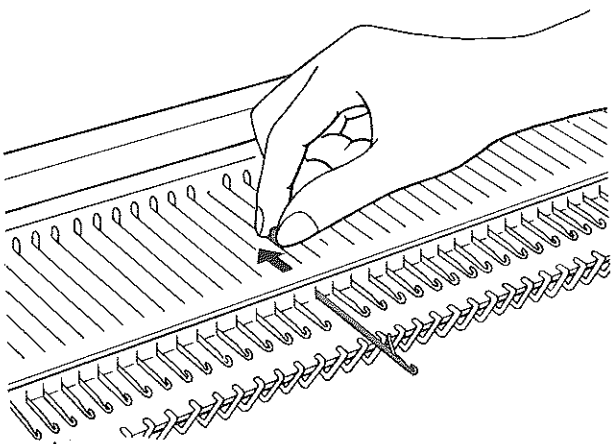

5. Push the needle back to A position by holding the butt.

6. Push the Needle Retainer back into the Needle Bed.

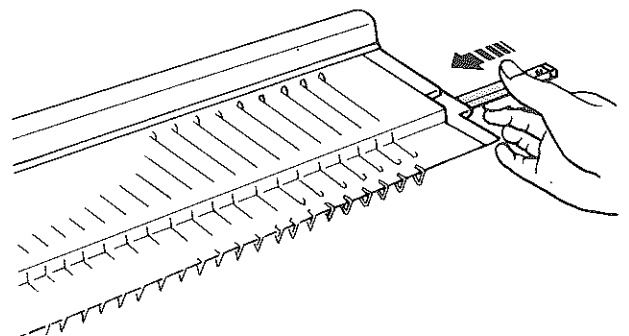

MAINTENANCE

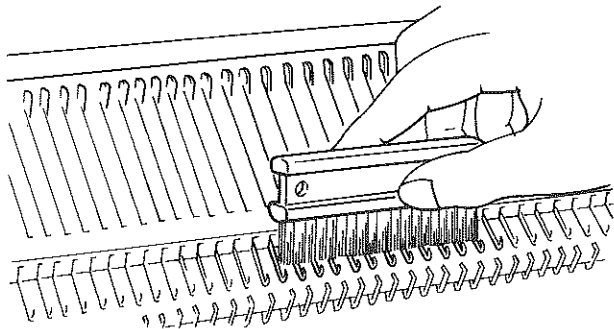

To clean your Knitter, remove the Carriage from the Needle Bed.

NEEDLE BED

Remove all lints using the Cleaning Brush.

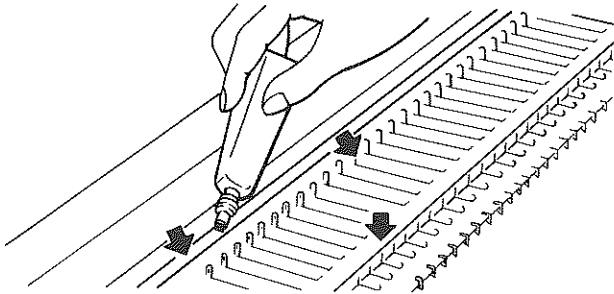

Apply oil along the rail and front guide of the Needle Bed.

With an oil soft cloth, wipe needle butts.

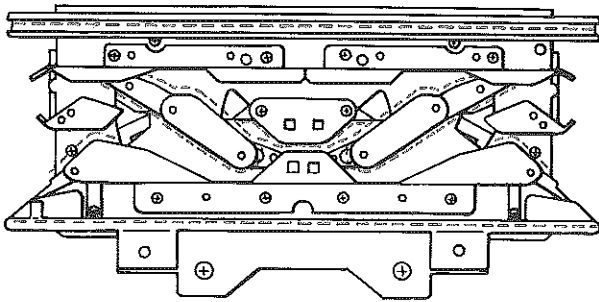

CARRIAGE

Turn over the Carriage and brush off all fluff and oil the side of all the metal parts and slider and Carriage pipe.

Wipe the places indicated by the dotted line in the diagram with a piece of oil cloth.

REPACKING THE KNITTER

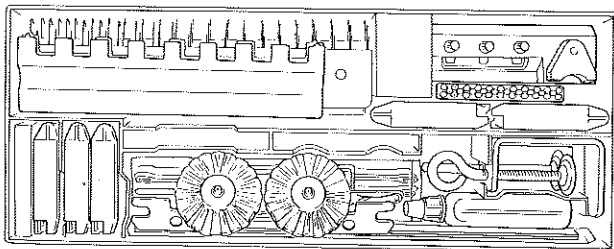

Replace the Accessories in the Accessory Box.

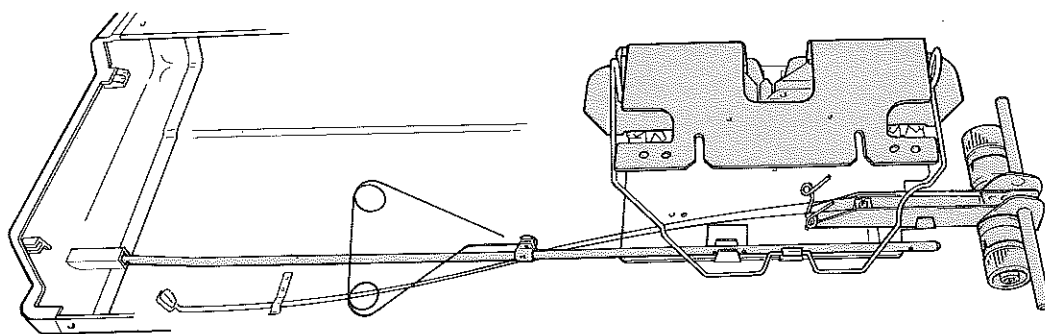

Remove the Auto Tension and Arm from the Knitter and pack them inside the Top Cover.

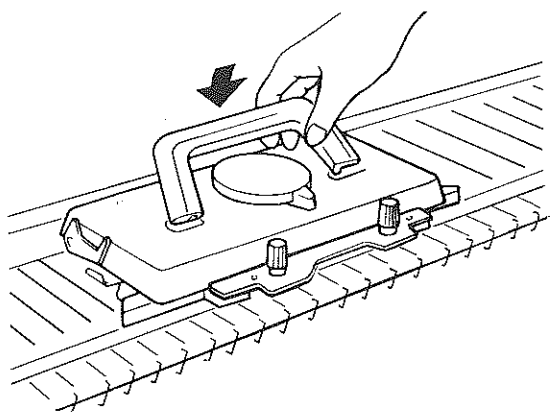

Lay the Carriage Handle down.

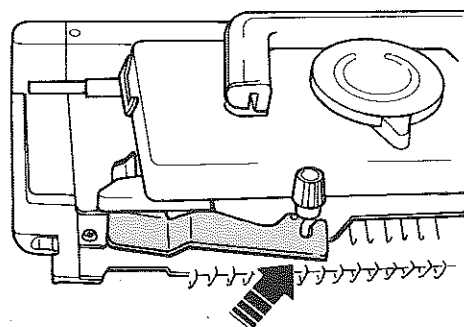

Secure the Carriage to the Needle Bed with the Carriage Fastener.

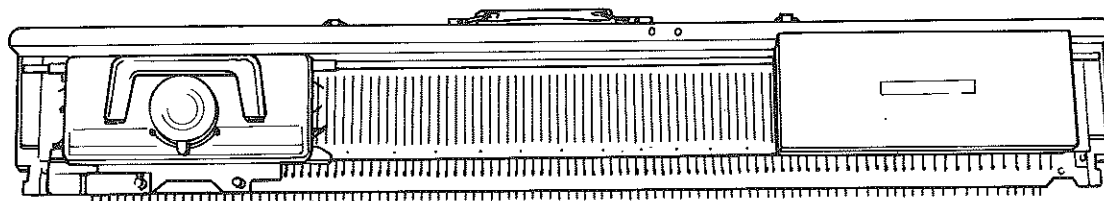

Place the Accessory Box on the right end of the Needle Bed.

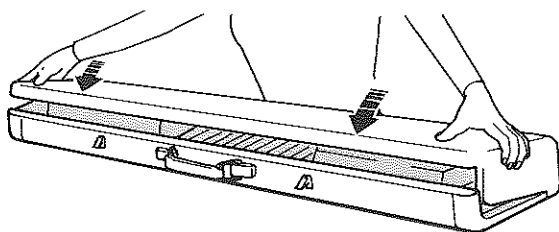

Place the Top Cover onto the Needle Bed.

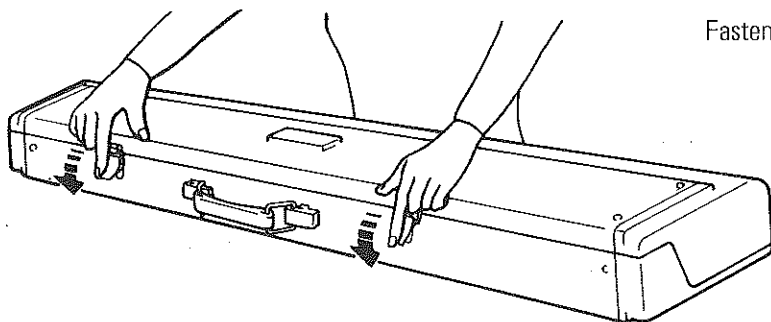

Fasten the latches.

TO STORE THE MACHINE

Keep the machine away from.

1. Too much moisture.
2. Abnormal change of temperature.
3. Salt or chemicals.

