

Service Manual for Modified KH-910

Electroknit



brother[®]

INDEX

*REMARKS

- I Modification point of new main P.C. board
- II Before trouble shooting
- III Test program
- IV Checking procedure for finding cause of wrong needle selection
- V How to adjust the carriage
- VI Needle selection mechanism (Mechanical part)
- VII Checking the power supply system
- IIIX Checking the needle position detect circuit
- IX Checking the needle selector solenoid
- X Checking and adjustment of the card reader

I MODIFICATION POINT OF NEW MAIN PC BOARD

*REMARKS

KH-910 has two types of main PC board assembly, one is the current type (410866001) and the other one is the modified type (412814001).

The checking methods of the machine is different according to the type of it, therefore, check and find that whether the type of it is current or modified before checking.

HOW TO CHECK AND FIND THE TYPE OF MAIN PC BOARD ASSEMBLY

1. When the pattern case whole unit is mounted on the machine.

- Give the input of 880 and push the M key when the READY lamp lights.
If the number "880" appears in the display, it is current type of the main PC board assembly.
If the different number appears in the display, it is modified type of the main PC board assembly.

2. When the pattern case whole unit is not mounted on the machine

- Check the wrong side of the main PC board assembly.
If it installs some new parts of the main PC board, it is modified type of the main PC board assembly.
If you find the soldering side of main PC board assembly, it is current type of the main PC board assembly.

1. Pattern position key lamp

Computer requires selection of pattern position key (yellow or green key) when this lamp is lit.

This lamp also will be lit when moving the G carriage from the outside of the turn mark and into the machine.

When both ready lamp and pattern position key lamp are lit, computer makes needle selection for the G carriage.

2. Card feed timing

In case of the K or L carriage, it must pass the center of the needle bed (Needle No. green I).

A card is fed when the K or L carriage turns after passing the center. For G carriage, it is not necessary to pass the center. A card is fed when the G carriage turns after moving 34 needles in same direction.

3. Pattern selector

There are three different positions and they are as follows:

UPPER : position for the pattern A (A motifs)

MIDDLE : position for the pattern A + B (A & B motifs)

LOWER : position for the full needle pattern (All over pattern)

(Current)

When setting the pattern selector to the lower position from upper or middle position and back it to the original position, all the programming of the pattern A or A + B is changed to the full needle pattern.

(It means, computer fixes the F.N. position and the pattern width of pattern according to the full needle pattern automatically.)

(Modified)

Three different pattern programming (A, A + B, or full needle pattern) is memorized by computer respectively. It means, the pattern programming is not changed even if the position of pattern selector is changed.

4. Changing the pattern variation switches and/or the programming while pattern knitting

(Current)

- 1) Fill in the corresponding L window which is the changing position (row) of pattern variation switches and/or the programming.
- 2) Knit until the reference mark at the L window comes to the card inlet.
- 3) Reset the pattern variation switches and/or the programming.
- 4) Enter the row number of the reference mark at the L window and push "CF" key. And continue to knit.

(Modified)

- 1) Fill in the corresponding L window which is the changing position (row) of pattern variation switches and/or the programming.
- 2) Knit until the reference mark at the L window comes to the card inlet.
- 3) Reset the pattern variation switches and/or the programming and continue to knit.

REMARKS:

In case of using the reflection switch, and knitting the pattern from top to bottom, even if the reflection switch is released while pattern knitting, computer makes the selection according to the reflection switch until its pattern comes to the last (bottom) row.

5. Memory retention

(Current)

Built-in batteries keep the memory even if the power switch is turned off. When the batteries expire, the number "888" appears on and off in the display.

(Modified)

The condenser keeps the memory for about three weeks after the power switch is turned off. It is not necessary to install the batteries. For the safety sake, it is advisable to check the memory when the power switch is turned on.

6. "CF" key

(Current)

The "CF" key can be operated only one time without pushing the numeral keys after the ready lamp is on or after pushing the "RR" key.

(Modified)

The "CF" key can be operated only one time after pushing "RR" key while

the ready lamp is lit.

If the "CF" key is pushed repeatedly, the error lamp will be lit.

7. "CR" key

After entering the figure and pushing the "CR" key, you must select the needles by operating the carriage

If you push the "CR" key again without making the needle selection...

(Current)

The pattern card does not feed to the correct position.

(Modified)

The error lamp is lit.

8. While the pattern selector pilot lamp is lit

(Current)

Computer does not accept any entries except for "M" key.

(Modified)

Computer will accept following entries, and add the following new functions.

* Enter 999 and push "M" key.

- 1) You can change the F.N. position of full needle pattern. Set the pattern selector at the lower position and push "M" key repeatedly.

The step lamp for the F.N. position will be lit.

You can change the F.N. position of full needle pattern while this step lamp is lit.

- 2) You can change the function of reflection switch to "Upside-down".

* Enter 990 and push "M" key.

All the changing of the function is back to the normal condition.

9. While the ready lamp is lit

(Current)

Computer will not accept the "M" key after pushing the numeral key.

(Modified)

You can check the machine with the test program by entering the test No. and push "M" key.

* Refer to the item "Test program".

II BEFORE TROUBLE-SHOOTING

10. The needle selection condition

- 1) When operating the K carriage without passing it to the turn mark.
(Current)
Computer makes wrong needle selection and the pattern card is not fed correctly.
(Modified)
The pattern card is not fed and the mark sensor does not move. All the needles are selected to position B.
- 2) If the pattern card is stained by oil or not written with the specified marker or pencil, the mark sensor can not read it.
(Current)
Computer makes wrong needle selection.
(Modified)
All the needles are selected to position B.
- 3) In case of operating the carriage when the row number of the L window at the card inlet is beyond the dimension of the selected pattern.
(Current)
The pattern card is fed and computer makes the needle selection according to the reading information of the mark sensor.
(This means, you can not get the proper needle selection.)
(Modified)
The pattern card is not fed and the mark sensor does not move. All the needles are selected to position B.
- 4) In case of operating the carriage while the ready lamp is not lit.
(Current)
The pattern card is fed when turning the direction of carriage but the needle selection will not be changed.
(Some needle selection appears repeatedly.)
(Modified)
The pattern card is not fed and the mark sensor does not move. The needle selection does not change.

Try to find out the cause of trouble by asking questions on the following items.

1. Kind of the pattern knitting and the pattern card No. selected. If any card drawn by hand is used, receive it together with the machine to check if the drawing is made correctly.
2. Check the fabric of wrong needle selection to judge the cause on the knit fabric.
3. Make sure that the input procedure of the operation panel is correct.
 - * Is the first needle position input correct?
 - * Is the set line fitted correctly?
4. Check the following items to make sure that the operation procedure is correct.
 - * Is the turn mark " | C " or " | " passed over?
 - * Has the carriages passed the center of the machine?

Since the electronic knitting machine is subjected to wrong needle selection rather often by mis-operation due to inexperienced handling, check the following points.

Needle selection error by defective pattern card

- 1) Pattern column of the pattern card is stained.
 - * Stained by oil or hands or not written with the specified marker or pencil.
 - * Error drawing is not erased completely.
- 2) Drawing on pattern card is error.
 - * Drawn out of the checkers.
 - * Not drawn in even tone.
 - * Drawing on erased part is error.
- 3) The pattern card is creased by folding.

Needle selection error by mis-operation

- 1) The set line of the pattern card is not fitted to the card inlet.
- 2) The pattern card is not advanced correctly.
 - * The carriage has not passed the machine center at each row.
 - * The ERROR lamp is on or flashing.
 - * Pushing of the CF key is neglected.
 - * The READY lamp is not on.

- 3) Wrong needle selection or all the needles are not at B position and not selected to D position.
- The carriage failed to go past the turn mark at successive knitting after power off for suspension.
 - The carriage failed to go past the turn mark when the change knob is turned to "N.L." in the middle of the pattern knitting, then pattern knitting is continued again.
 - The CF key is not pushed.
 - When the pattern selector is changed, the number in L window at the card inlet is not included in the range of the programed upper and lower by the pattern select.

HOW TO CHECK DEFECTIVE POINT OF PATTERN CARD AND CORRECTION

If the pattern card seems defective, remember the needle number of wrong selection. Aline the needles at B position, then push the "CR" key. (ERROR lamp flashes on and off.)

Depress both "PART" buttons of the carriage and set the change knob to the "KC (II)" for needle selection.

Then move the carriage for checking the needle selection.

If the error is found, check the pattern column of the number indicated in L window of the pattern card at the card inlet or preceding row and re-write.

Note : Even for lace pattern, check by selecting with K carriage. If L carriage is used for needle selection while keeping the ERROR lamp flashing, the pattern is deflected by 8 needles to the left or right.

BE SURE TO MOVE THE CARRIAGE THROUGH THE LEFT OR RIGHT TURN MARK AT ANY ONE OF THE FOLLOWING CONDITIONS

1. When the power is cut off in the middle of knitting operation, the computer fails to know the previous carriage position even if the power is turned to on again. It is necessary to inform the carriage position by moving the carriage through the turn mark.

2. When the change knob is switched to "CR" or to "N.L." in the middle of pattern knitting (When plain knitting is inserted in the middle of the pattern knitting then the change knob is turned to "KC (I)" or "KC (II)" to continue pattern knitting again), not knowing that the carriage once went off the belt, the computer judges the carriage position differently from the actual position for needle selection. It is necessary, therefore, to move the carriage through the turn mark to inform the correct carriage position.

THE "CF" OR "RR" KEY DOES NOT FUNCTION

The "CF" key and the "RR" key can be pushed only once alternatively. When the power is turned off and pattern card is returned by the card feed dial and not by the RR key, the next card inserted and fitted to the set line is not advanced even when the CF key is pushed, and the ERROR lamp lights.

When the CF key is pushed after designating the row to start knitting, the pattern card stops at a position different from the designated position because the card is sent from the position memorized previously to the designated row.

When the pattern card is taken out and pattern knitting is performed with a new card, therefore, be sure to push the RR key before taking out the old card.

III TEST PROGRAM

With the modified main PC board assembly, it is possible to check whether or not the card reader, needle position detect circuit, pattern variation switches, and needle selectors etc. are working normally by the computer.

* Before checking by the computer, make sure that the power supply, the keys and the lamps on the operation panel are free from any abnormal condition.

TEST PROGRAM START

- * Move the carriage out of the turn mark. If a card is necessary for the test, fit the set line of the card to the card inlet.
- * Make sure that the READY lamp is on, then push the M key after input of the test number 880 ~ 889. The test starts.
- * At the end of the test program or before starting another test program, turn off the power switch.
- * Once a test is made by a test program in the middle of pattern knitting, knitting of the same pattern can not be continued. (Except for test No. 880)

TEST NUMBERS

- 880 : Indicates the content of card position memory.
- 881 : Card read test is performed by pattern card No. 1.
- 882 : Card read test is performed by the test pattern card.
- 883 : Card is advanced by each row from row No. 1 to No. 150.
- 884 : The mark sensor is operated in succession.
- 885 : The needle position detect circuit is checked.
- 886 : The position of carriage sensor magnet is indicated.
- 887 : Needle selection test is carried out with four kinds of needle selection test patterns without using the card.
- 888 : Memory test.
- 889 : The pattern selector and the pattern variation switches test.

Test 880 — Indication of card position memory

The content of the card position memory should always be in conformity with the number of L window of the card inlet.

These always coincide so long as the card set line is set correctly, when the power switch is turned to off after pushing the CF key, the card feed dial is not turned, or the card feed mechanism is free from any abnormal condition.

- * Knitting of the same pattern can be continued after this test is made in the middle of a pattern knitting.
- * Pattern knitting is not possible while showing the content of the card position memory.

Test 881 — Card read test by pattern card No. 1

Four stitches from stitch No. 1 to 4 of the row number 1, 2, 137, and 138 of the pattern card No. 1 are read two ways of each row so as to check for correct reading.

Card feed sequence:

Set line → 1 → 2 → 137 → 138 → 150 → 138 → 137 → 2 → 1 → Set line

If the reading is acceptable, the card returns to the set line and the READY lamp lights.

At a read error, the card stops at the row, the ERROR lamp turns on, and the error No. is indicated.

At a stop by error, push the M key, then reading starts again from the row. When the RR key is pushed at a stop by error, the card returns to the set line.

Re-start is possible by the M key.

Error No.

1. The mark sensor does not run or fails to read even one stitch of the card.
2. The mark sensor can not read up to 60 stitches.
3. Read data is not correct.

* When the ERROR lamp lights and the error No. is indicated, check and adjust by referring to following item.

Error No. 1:

Push the M key to continue the test after removing the needle selector panel and check the movement of the mark sensor.

If the mark sensor does not move, check the mark sensor drive mechanism and drive circuit by referring to "CHECK AND ADJUSTMENT OF THE CARD READER" — *The mark sensor does not move.

When the mark sensor can move, there is any defect on the mark sensor.

Check and adjust the voltage of the check pin (CH501) by referring to "CHECK AND ADJUSTMENT OF THE CARD READER" — *Adjustment of the mark sensor.

Error No. 2:

Check the pattern card and the card guide A.

- * The pattern card is stained by oil.
- * The pattern card is creased by folding.
- * The specular surface of the card guide A is stained by oil.

If there is no defect on the pattern card and the card guide A, there is poor adjustment of the mark sensor, check and adjust the voltage of the check pin (CH501) by referring the "CHECK AND ADJUSTMENT OF THE CARD READER" — *Adjustment of the mark sensor.

Error No.3:

Check the voltage of the check pin (CH501) when the mark sensor reads the black part of the pattern card.

If it is not less than 1.0 V, check again the voltage of the check pin (CH501) when the mark sensor read the special card for checking. If there is no defect on the level of the mark sensor, check and adjust the position of a card to the mark sensor by referring to "CHECK AND ADJUSTMENT OF THE CARD READER" — *Adjustment of the card position.

Test 882 — Card read test by test pattern card

The operation is the same as that of test 881.

The test pattern card is used in place of the pattern No. 1 card. The reading is judged by one going and return of the 60 stitches from stitch No. 1 to No. 60 of the row No. 53 — 60, and 91 — 98 of the test pattern card.

Test 883 — Card feed test

There is no judgement by the computer for this test.

A card is advanced from No. 1 to 150 by each row in two ways.

- * The test stops when the M key is pushed in the middle, and starts again from the position when the M key is pushed again.
- * If the RR key is pushed while the test is suspended, the card returns to the set line.
- * Re-start is possible by pushing the M key.

Test 884 — Mark sensor continuous operation

This test is not for judgement of the read data. If reading of 60 stitches fails, however, the operation is stopped as an error. This is used to adjust reading level by means of a synchro-score or to test the mark sensor drive system.

- * Turn off the power switch, set the card so that the row of the card to be measured comes to the center of the window of the card guide A, then turn on the power switch.
- After input of 884, push the M key, then the mark sensor starts to reciprocate.
- * Stop and re-start are repeated at every push of the M key.
- * At an error, the test is suspended, the error lamp lights, and the error No. is indicated. The test starts again when the M key is pushed.

Error No.

- 1 : Same as error No. 1 of test No. 1
- 2 : Same as error No. 2 of test No. 1

Test 885 — Needle position detect circuit test

The needle position detect circuit is tested at three steps.

- Step 1 : No output of the right and left position signal shall be made when there is no sensor magnet of the carriage in front of the right and left turn marks.
- Step 2 : The phase difference between encoder signal V1 and V2 shall be more than 100 μ s.

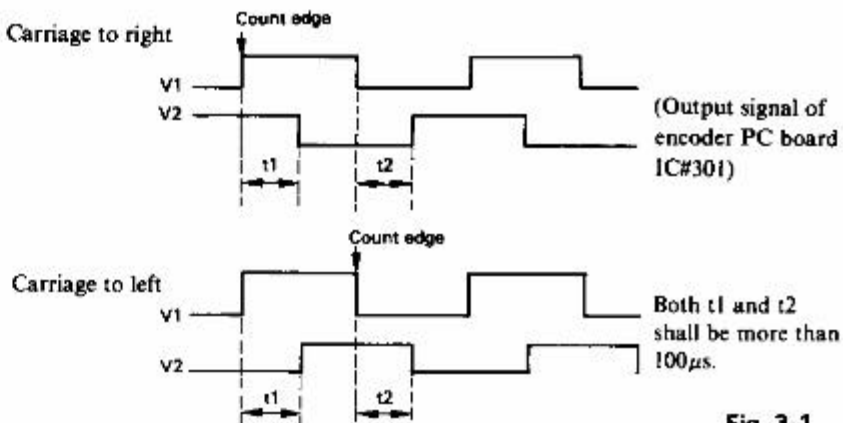

Fig. 3-1

Step 3 : Belt phase signal margin test.

When the carriage goes past the turn mark, the kind of the carriage and the level of the belt phase signal at that time are detected.

The belt phase signal shall have another count edge during the time from the initial V1 count edge in the right or left position signal to the belt phase signal reversing.

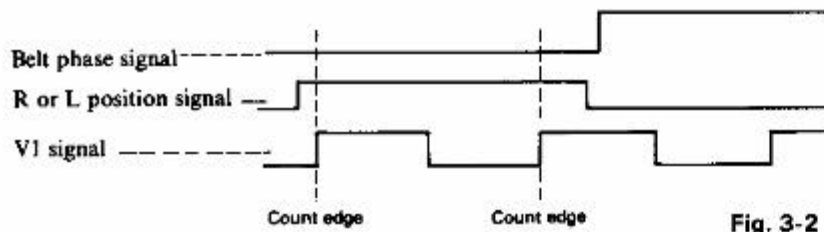

Fig. 3-2

Test procedure:

- 1) Move the sensor magnet of the carriage out of the turn mark, then turn on the power switch.
- 2) Push the M key after input of 885.

The READY lamp lights if no output of the right or left position signal is given at the test of step 1.

If the R and/or L position signal output is given, the ERROR lamp lights and the error No. is indicated.

The error No. indication is in two digits, the 1st digit shows the information of the right turn mark, and the 2nd digit indicates the information of the left turn mark.

1st digit (Right side)	2nd digit (Left side)
0 : No signal	Off : No signal
1 : K carriage signal	1 : K carriage signal
2 : L carriage signal	2 : L carriage signal

Example : If 20 is indicated;

The computer detected the left position signal for L carriage and no right position signal.

* If the error lamp lights, the test step does not advance. When the M key is pushed, the test starts again from step 1. The same is true if the error lamp lights at step 2 and 3.

- 3) When the READY lamp is turned to on, move the carriage from the outside of the turn mark to the center of the machine

(For K carriage, set the change knob to "KC (I)" or "KC (II)".)

When the test of step 2 starts, the READY lamp goes off, and step 2 is normal, the test advances automatically to step 3.

If step 2 is found abnormal, the ERROR lamp lights and the error No. is indicated.

Error No.:

4 : The phase difference between V1 and V2 is less than 100 μ s.

5 : V2 remains at L level and does not change while V1 is at H.

6 : V2 remains at H level and does not change while V1 is at H.

- 4) When the R or L position signal is checked at step 3 and the margin test of belt phase signal is cleared, the READY lamp turns to on, and the kind of carriage and the belt phase signal level at that time are indicated by a numeric character of two digits.

If it fails to pass the margin test of belt phase signal, the ERROR lamp lights and error No. 7 is indicated.

* Indication when the tests up to step 3 are cleared.

1st digit : Belt phase signal level	2nd digit : Kind of carriage
0 : L	1 : K carriage
1 : H	2 : L carriage
	3 : G carriage

Test 886 — Needle No. indication

The position of carriage sensor magnet (the outside magnet in advancing direction for G carriage) is indicated by the needle number (the number of the needle position indicator).

Under normal condition, the difference between the actual position of the sensor magnet and the indication needle number is one needle in transversal direction.

* The indication starts when the sensor magnet of the carriage goes past the turn mark.

Test 887 — Needle selection test

Needle selection test is possible with four kinds of pattern without using any card. The computer makes no judgement for accept or reject.

The test is not affected by the data programmed before the test, position of the pattern selector, and on or off of the pattern variation switches.

Needles are selected under condition of Double length at all times with the First needle position of yellow 100 and the Pattern width of yellow 100 — green 100.

- * Move the carriage out of the turn mark.
- * While the READY lamp is on, give the input of 887, and push the M key, then the test of pattern 1 starts.
- * Pushing the M key changes the pattern to 2, 3, 4 and 1 in order.

Pattern 1 : 1 x 1 alternative needle selection



Pattern 2 : 5 x 5 alternative needle selection

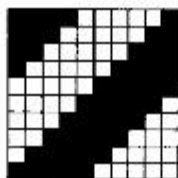

Pattern 3 : 1/16 needle selection

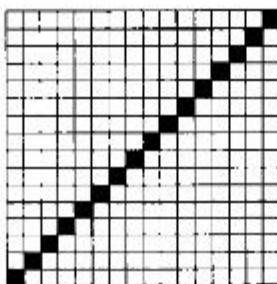

Pattern 4 : 1/5 to 5/5 needle selection



Fig. 3-3

Test 888 — Memory test

The computer tests the memory. All the contents of the memory are cleared when this test is performed.

Accordingly, 1 is written always as the content of the program memory when the power is on.

Test detail:

1 is written in the whole memory area and it is judged whether or not 1 is written. Then 0 is written (clear) and clearing of the whole area is checked. If the result is accepted, the READY lamp turns to on. If rejected, the ERROR lamp lights and the error No. is indicated.

Error No.:

- 8 : The memory includes a part which is not cleared.
- 9 : The memory includes a part into which no writing is possible.

* Re-start is possible by pushing the M key.

Test 889 — Pattern selector and pattern variation switches test

The No. of the switch turned to on is indicated.

If two or more switches are on, the one with smaller No. is indicated. The lower position of pattern selector, however, is indicated as "0" only when all the switches are turned to off (down).

- | | |
|----------------------------|-----------------------|
| 0 : Full pattern (Lower) | 1 : Pattern A reverse |
| 2 : Pattern B reverse | 3 : Double width |
| 4 : Double length | 5 : Reflection |
| 6 : Negative | 7 : KRC |
| 8 : Pattern A + B (Middle) | 9 : Pattern A (Upper) |

IV CHECKING PROCEDURE FOR FINDING CAUSE OF WRONG NEEDLE SELECTION

1. Checking of the carriage and the needle selection mechanism (Power is turned off.)

- * Aline all needles at B position, set the change knob of the K carriage to "KC (II)", then operate the machine at low-speed and high-speed.
- * After operating the K carriage, all needles alined at B position should be selected at D position.
Refer to "HOW TO ADJUST THE CARRIAGE" or "NEEDLE SELECT MECHANISM" if any defect is found.

2. Checking of the power supply system

- * After checking that the power switch is OFF, connect the power cord, and turn on the power switch.
- * a. The power pilot lamp (the green lamp at the left side of the row counter) shall be ON.
- b. The buzzer shall make a sound.
- c. The READY lamp in the pattern case is lit. (All the other lamps should be off.)
- d. The mark sensor should be returned to the left side if it is in the middle or at the right of the card reader.
- e. Turn the card feed dial for trial. Click sound of dial slip indicates normal condition. If a card is in, the card is not advanced even if the dial is turned. Refer to "CHECKING OF THE POWER SUPPLY SYSTEM" if only defect is found.

3. Checking the pattern case.

3.1 Check the display.

- * Push the "8" key three times.
- * The buzzer makes a sound and 8, 88 should be indicated in the display at every pushing of the key.

3.2 Check the CE key. (CE Clear Entry)

- * Push the CE key.
- * The buzzer should make a sound and the display should go off.

3.3 Check the numeral keys.

- * Push the numeral key in order from 1 to 2,3,....
- * The buzzer should make a sound and the number of the pushed key should be indicated in the display at every push of the key. When a three digit number is indicated in the display, the indication must be cancelled by the CE key to continue checking since no numeral key is accepted.

3.4 Check the CF key. (CF Card Feed)

- * Push the CF key.
- * The card feed dial should turn while the buzzer is sounding, then the mark sensor should go and return for one time.
Note : The CF key can not be operated repeatedly. If the CF key does not work, operate it after pushing the RR key.

3.5 Check the CR key. (CR Correction)

- * Push the CR key.
- * The buzzer should make a sound and the ERROR lamp should flash.
- * Push the CE key. The ERROR lamp will go off.

3.6 Check the RR key. (RR Return & Reset)

- * Push the RR key.
- * The card feed dial should turn in reverse way while the buzzer is sounding.

3.7 Check the M key and the step lamps. (M Memory)

- * Push the M key.
- * The READY lamp goes off and the pattern selector lamp is lit up.
- * At another push of the M key, the memorized lower number of the pattern is indicated in the display.
Make sure that the step lamps are turn to on in sequence by pushing the M key in succession.

- Also make sure that the pattern position key lamp lights when the lamp of step No. 5 is on, then push the yellow pattern position key. The yellow pattern position lamp lights at the left side of the display.
- After push the CE key, push the green pattern position key to check that the green pattern position lamp lights in the same manner.
- Push the CE key and by pushing the M key, continue checking of the step lamps to the point where the READY lamp lights.

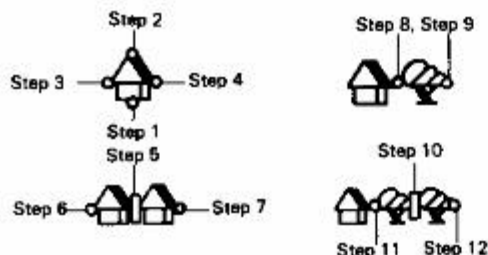

Fig. 4-1

3.8 Check the pattern variation switches.

- Set all the pattern variation switches and the pattern selector at the lower side, make sure that the READY lamp is on, give the input of 889, then push the M key.
(Refer to "TEST PROGRAM" Test No. 889.)

- Indication of "0" is given showing that the mode is FULL PATTERN.
- Check the pattern variation switches by turning up and down from the left one to the right.
- The number of the switch set up is indicated.
If two or more switches are set at up, the number of the switch set at left side is indicated.

Switch No.

1 : Pattern A reverse	2 : Pattern B reverse
3 : Double width	4 : Double length
5 : Reflection	6 : Negative
7 : KRC	8 : Pattern A + B
9 : Pattern A	0 : Full pattern

- If any defect is found while checking the above item 3.1—3.8, replace the pattern case whole unit or the main PCB. assembly with a new one.

4. Checking the needle position detect circuit

- Aline all the needles at A position, place the K carriage out of the turn mark and set the change knob to "KC (I)" or "KC (II)", then turn on the power switch.
Give the input of 886 while the READY lamp is on, then push the M key.
- The indication of the position of carriage sensor magnet (the outside magnet in advancing direction for G carriage) by the needle number (the number of the Needle position indicator) starts when the sensor magnet of the carriage goes past the turn mark.
- Under normal condition, the difference between the actual position of the sensor magnet and the indication number is 0 or 1.
If it is more than 1, the position of the position sensor board assembly is not proper.
Adjust the mounting position of it properly.
- If the difference between the actual position of the sensor magnet and the indication number is growing up while moving the carriage, check the rotary encoder and/or replace the encoder board assembly.
- If no indication appears in the display, check the right or left position sensor and/or encoder board assembly by referring to "CHECKING THE NEEDLE POSITION DETECT CIRCUIT".

5. Checking the needle selector solenoid

- Aline an adequate number of needles at B position and push the RR key.
Set the change knob to "KC (II)" and move the K carriage to the other side and bring back to the starting side.
- All the needles are alined at B position.
- If there are some needless selected at D position every 16th needles the needle selector solenoid corresponding to the needle (see Fig. 9-3) is not turned on.
Refer to "CHECKING THE NEEDLE SELECTOR SOLENOID".

6. Checking the card reader

- Turn off the power switch and attach the card guide.
Insert the pattern card No. 1, and turn the card feed dial to fit the set line of the card to the card inlet.
Turn on the power switch. (Make sure that the card inlet coincides with the set line of the card.)
Push the M key after input of 881, then the test starts.
- If nothing is wrong, the READY lamp lights and the test completes.
- If the ERROR lamp lights and 1, 2 or 3 is indicated in the display, there are some defects.
Refer to the "TEST PROGRAM" and also "CHECKING THE CARD READER".

V HOW TO ADJUST THE CARRIAGE

1) CHECKING THE FUNCTION OF THE CARRIAGE

1. Change knob function.

When the change knob is changed to each position [N.L., KC(I) or KC(II)] it should move smoothly.

The right and left connecting plates, sensor magnet, separation cams and needle selector change cams should work without fail.

2. MC cam operation.

When the end of right or left MC cam are pressed fully down and the gently lifted with your finger while keeping the MC cam button depressed all the time, the right and left MC cams should return to their original position by spring pressure.

3. MC knitting change cam operation.

The right and left parts of MC cam should shift without fail while the MC cam button is kept depressed.

4. Raising cam operation.

When the end of the right or left part of the raising cam is lifted fully with the stitch dial at 0.5 or 10 position and gently lowered with your finger, the right or left parts of the raising cams should be returned to their original position without fail by the spring pressure.

5. Needle selection change cam operation.

When the change knob is set at "KC(I)" or "KC(II)", and when the end of the right or left part of the needle selection change cam is lifted fully and then gently lowered with your finger, the cams should be returned to their original position without fail by the spring pressure.

6. Separation cam operation.

When the change knob is set at "KC(II)", the separation cam should move freely. When the change knob is set at "KC(I)", the separation cam should not move. The clearance between the separation cam and the needle selection cam must be less than 0.5 mm.

7. Tuck cam operation.

When the left and right tuck cam buttons are depressed, by gently lifting the left and right tuck cam, they should return to their original position when released. When the cam button is set to plain, the end of the tuck cam fingers can be gently moved and they should return to their original position when released.

8. Cam button unit function.

When the cam button is changed to "TUCK R & L", "MC" or "PART R & L", they should move smoothly. The tuck cam, MC cam or raising cam should work without fail.

9. Holding cam lever function.

When the holding cam lever is changed to "H" or "N", it should move smoothly.

10. Plain knitting cam function.

When the plain lever is moved to right while pressing "TUCK R & L", "MC" or "PART R & L" buttons, the lever should move smoothly and the cam buttons should return to their original position without fail.

11. Make sure that the needle butt passes smoothly through the following. (Fig. 5-1)

- 1) Between the separation cam and rear foot.
- 2) Between the tuck cam plate and guide cam C.
- 3) Between the guide cam C and slide cam.
- 4) Between the sub stitch cam and guide cam B.
- 5) Between the needle selection cam and guide cam A.
- 6) Between the needle selection cam and guide cam G.
- 7) Between the guide cam A and B.
- 8) Between the guide cam F and separation cam.

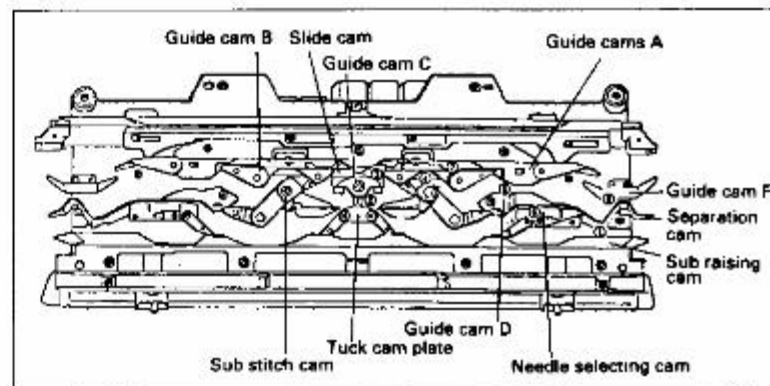

Fig. 5-1

2) HOW TO ADJUST THE CARRIAGE

1. The K carriage does not move smoothly.
 - 1-1. Carriage rail lacks oil.
Oil needle butts and stitch cams.
 - 1-2. Needle bed rail lacks oil.
Oil front and rear rails of the machine body and carriage.
 - 1-3. The sinker plate is in contact with gate pegs.
Adjust sinker plate position.
 - 1-4. The sinker plate keeps the knitting needles up.
Adjust the gap between the sinker plate and the needle.
 2. The fabric floats (stitch float)
 - 2-1. The sinker plate is in contact the gate pegs, or there is too much gap between the sinker plate and the gate pegs.
 - 2-2. The sinker plate keeps the knitting needles up, or there is too much gap between the sinker plate and the needle.
- * Position adjustment of the sinker plate. (Fig. 5-2).
1. Mounting dimensions of sinker plate.
The sinker plate should be 118.5 mm apart from the carriage rear leg. If it is not correct, loosen screws and adjust.
 2. Mounting dimensions of yarn feeder.
The yarn feeder should be 120.5 mm apart from the carriage rear leg.

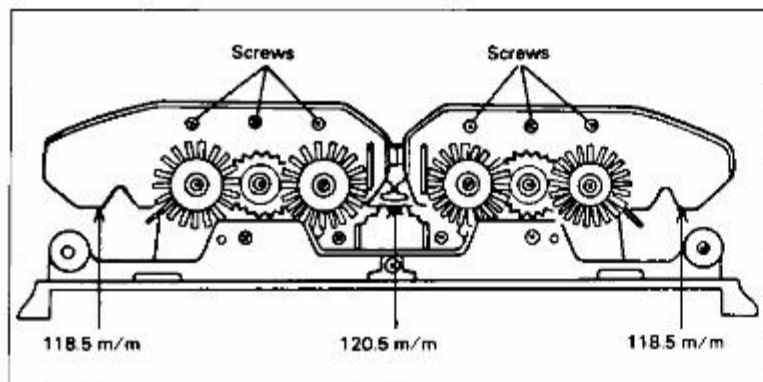

Fig. 5-2

* Vertical adjustment of the sinker plate. (Fig. 5-3).

1. Fit the carriage on the needle bed and set the holding cam lever at "H".
2. Bring about five knitting needles each to position E at the left end, center and right end of the needle bed.
3. Bend the sinker plate to adjust the gap between the knitting needle stem and the sinker plate 0.5 mm or less.

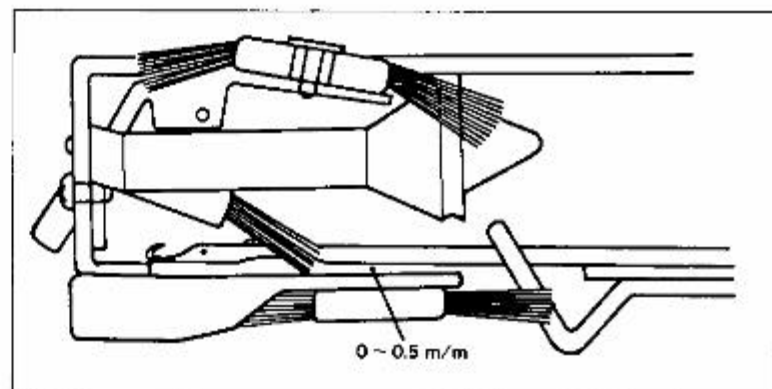

Fig. 5-3

3. A lateral stripe is produced every second row.
The right and left parts of the stitch cam are positioned differently.
- * The stripe adjusting plate is connected with the stitch cam, and the stitch cam guide plate is connected to the right and left stitch cams.
- 3-1. Loosen the stripe adjusting plate clamp screw. Use slide calipers to adjust the stripe adjusting plate so that the length (at a and a') of the right and left parts of the stitch cam are even. Then tighten the stripe adjusting plate clamp screw.
- Note : The length difference at the stitch cam (between a and a') should not exceed 0.35 mm.
- Hint : When the stitch dial is set at 5, the length at the stitch cam: 32.5 mm. (Fig. 5-4).

- 3-2. After adjustment, be sure to check it by knitting plain stitch using a medium yarn and the stitch dial set at 5.

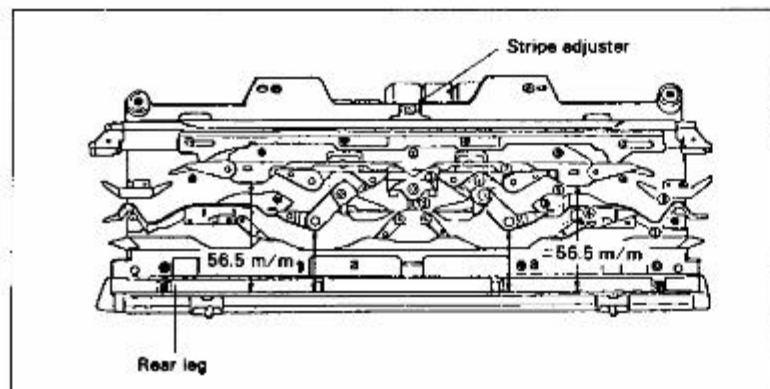

Fig. 5-4

4. The carriage does not move when needle selected B position.
The latch of the knitting needle is bent.

- 4-1. guide cam A is in wrong position.
Mounting dimensions of guide cam A.

1. Loosen the right and left guide cam A clamp screws and the plate clamp nut. Clamp again after adjusting the distance between guide cam A and the carriage rear leg to 56.6 mm. (Fig. 5-4).

Note 1 : If guide cam A is not more than 56.5 mm apart from rear leg, the gap between guide cams A and B will be too narrow for knitting needle.

Note 2 : If the distance between guide cam A and the rear leg exceeds 56.5 mm, the yarn guide might damage the latch.

5. The end needles do not come out.
Selection cam for end needle is broken.
Replace the selection cam for end needle. (Fig. 5-5).

1. Remove the carriage cover.
2. Remove the end needle selection cam spring.
3. Set the change knob to position "N.I.", and remove the guide cam G and needle selection change cam.

4. Remove the needle selection cam and separation cam.
5. Remove the valve cam F spring and valve cam F.
6. Loosen the carriage rear leg clamp screws, and pull off the selection cam for end needle.

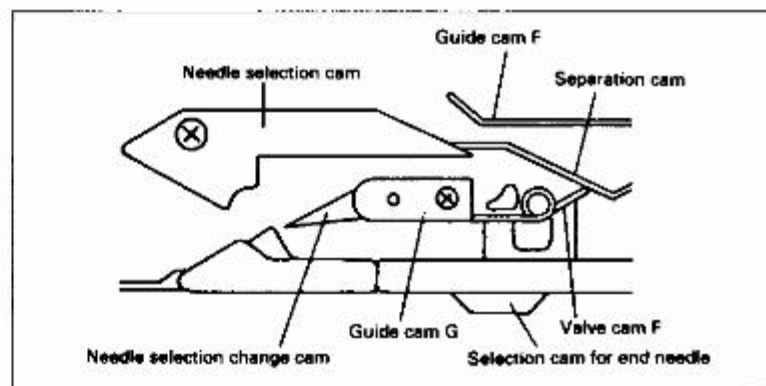

Fig. 5-5

3) HOW TO ADJUST L CARRIAGE

* Stitch drops

1. Wrong bilateral position of the leaf spring.
 - 1-1. Remove L carriage cover and loosen right and left clamping screws for the leaf spring.
 - 1-2. By referring to Fig. 5-6, place the leaf spring at a distance of 1.0-1.2 mm inward from the cross section of the plate cam B and fasten with clamping screws.
2. Wrong vertical position of the leaf spring.
 - 2-1. By referring to Fig. 5-7, adjust the tip of the leaf spring to the same level as that of the plate cam B.
 - 2-2. Although you may use a pincers or pliers in making such adjustment, be careful not to damage the leaf spring.

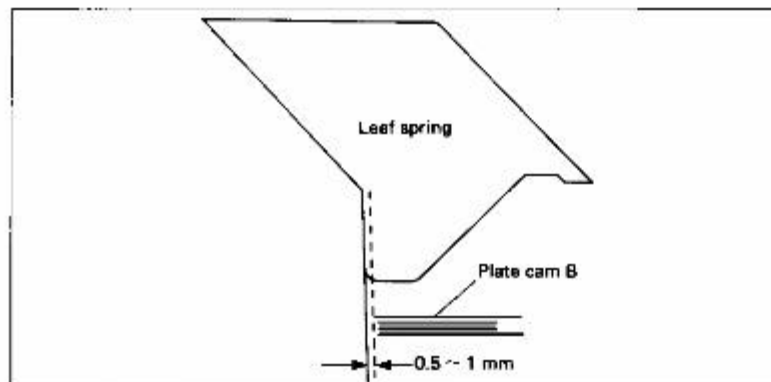

Fig. 5-6

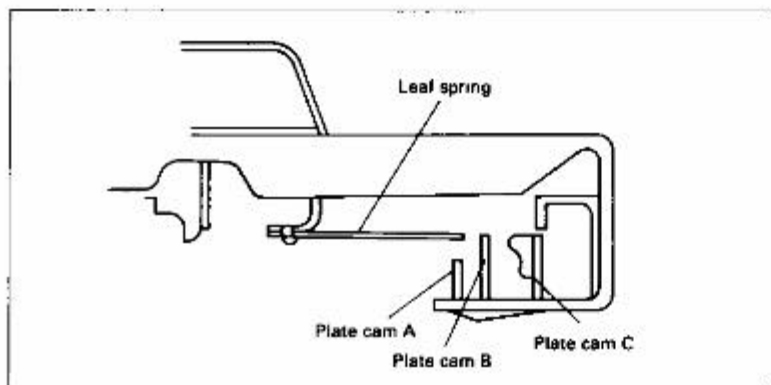

Fig. 5-7

3. Wrong position of the feed hook.

- 3-1. The feed hook is fixed with the feed hook clamping screw on the side of the sinker plate.
- 3-2. Loosen the feed hook clamping screw and move it inward and the amount of feed will get smaller but move it outward the amount of feed will get larger. (Fig. 5-8).

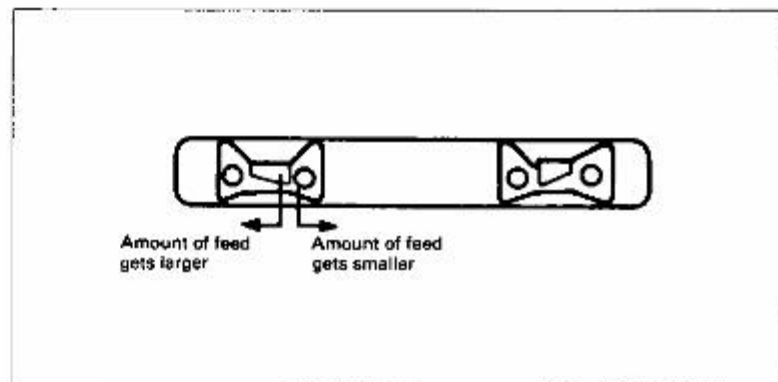

Fig. 5-8

- 3-3. By referring to Fig. 5-9, adjust the feed hook so as to have a gap of 0.2 ~ 1 mm between the crossed catch needles.

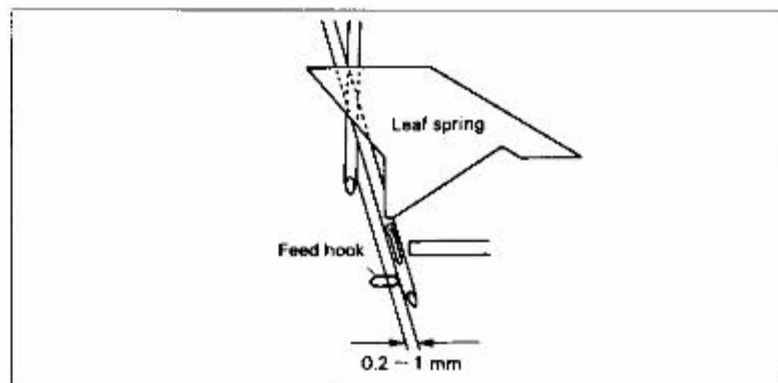

Fig. 5-9

4. When L carriage sinker plate is crooked. (Fig. 5-10).
 - 4-1. Observe the sinker plate sideward and see if it is crooked.
 - 4-2. After confirming it by visual observation, put L carriage onto the needle bed and pull out latch needles to the position D, then check the gap between the sinker plate and the stem of the latch needles. If latch needles are raised by the sinker plate (or there is a wide gap), adjust the "crooked" section.

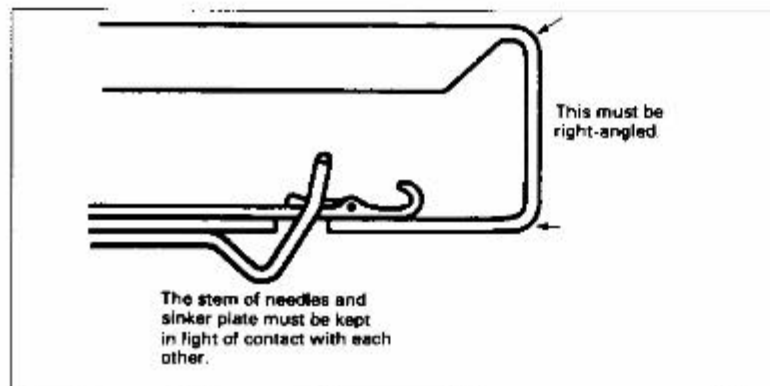

Fig. 5-10

5. When main cam is replaced.
 - 5-1. Remove right and left clamping screws for the L carriage cover and take off the cover.
 - 5-2. Remove clamping screws for separation cam and take off the separation cam.
 - 5-3. Remove clamping screws for main cam and take off the main cam.
 - 5-4. From the back side of the L carriage rear foot, measure by use of a sliding calipers to place main cam in such a way as shown in Fig. 5-11 and fasten with three clamping screws.
 - 5-5. Mount right and left separation cam and clamp with screws.

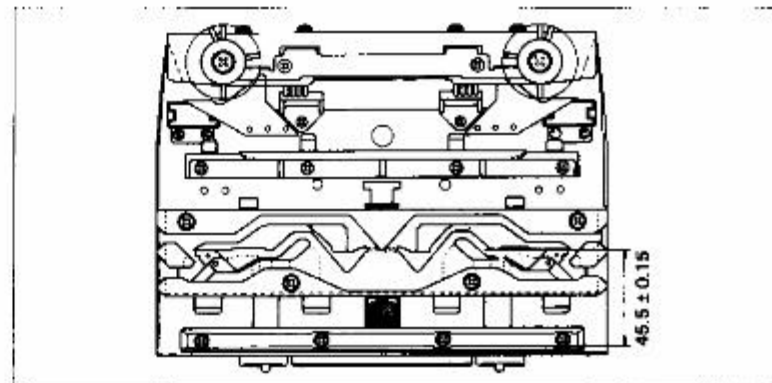

Fig. 5-11

VI NEEDLE SELECT MECHANISM (MECHANICAL PART)

Set the change knob to position "KC(II)", and move the K carriage across and back slowly and/or quickly to check the needle select mechanism.

After moving the K carriage to the other side of the machine, all the needles should be selected to position D.

1. If some needles do not come out to position D at random.
 - 1-1. Needle is bent.
Replace the needle with a new one.
 - 1-2. The timing belt and the rotary encoder assembly, the rotary encoder assembly and the rotary cam are not in the right relative position.
Adjust and re-mount them in the right relative position.
(See "Replacing the timing belt and the rotary encoder assembly").
 - 1-3. The card reader guide stopper is not mounted correctly, and the position of the rotary cam and the rotary cam lever are not correct.
Adjust the position of them.
2. If some needles do not come out to position D but are selected in eighth or sixteenth cycle.
 - 2-1. The rotary cam lever and the needle selector plate (N.S.P.) operation lever are not in the right relative position.
(Be sure to place the N.S.P. operation lever is on the left side of the rotary cam lever.)
 - 2-2. Squeezed between the rotary cam lever and the rotary cam lever guide, the rotary cam lever does not move smoothly. (Fig. 6-1)
 - 2-3. Squeezed between the armature and solenoid yoke of the needle selector solenoid, the armature does not move smoothly.
Put the specified grease on the armature sliding parts of the solenoid yoke.
 - 2-4. The spring for the armature is broken.
Replace the spring with a new one.
 - 2-5. Interfered between the operation lever presser and the N.S.P. 2.
 - 2-6. The N.S.P. spring is disconnected or interfered with the other spring.

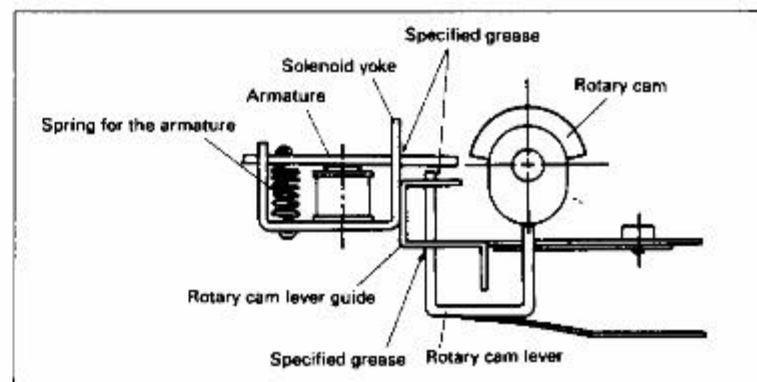

Fig. 6-1

3. K carriage movement is too heavy.
 - 3-1. When the K carriage does not move.
The rotary cam lever does not move correctly.
After making sure that the rotary cam lever is not bent, adjust the card reader guide stopper and the rotary cam position.
 - 3-2. When the K carriage is hard to push.
The clearance between the rotary cam and the rotary cam adjuster collar is too wide.
Adjust the rotary cam position.
4. Adjustment
 - 4-1. Adjustment of the rotary cam lever guide.
 1. Remove the pattern card from the card inlet and the needle selector panel assembly.
 2. Plug the power supply cord into the AC inlet and the other side of it into the wall outlet.
 3. Turn on the power switch and push RR key.
 4. Bring back all the needles to position A.
 5. Place the K carriage outside of the left turn mark " Ⓞ " and set the change knob to position "KC(I)" or "KC(II)".
 6. Move the K carriage across and back until all the needle selector solenoids are turned on and the mark sensor is on the left side.

7. Loosen the card reader guide stopper screw and slide the card reader guide stopper to left until the rotary cam levers touch softly to the right side of the window of the rotary cam lever guide. (Fig. 6-2)
8. Fasten the card reader guide stopper screw.

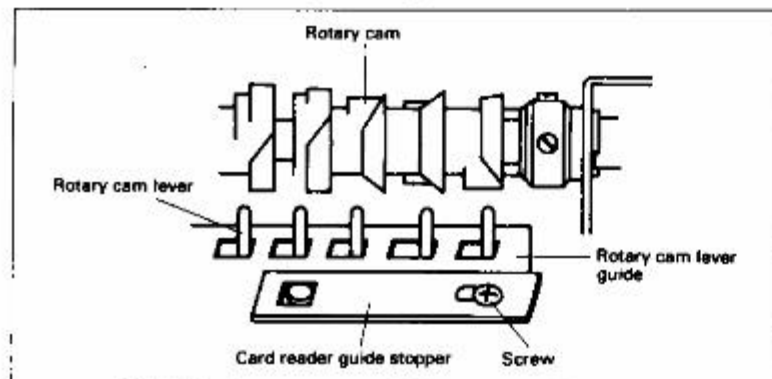

Fig. 6-2

4-2. Adjustment of the relation between the rotary cam and the rotary cam lever.

1. After adjusting the rotary cam lever guide, loosen the two rotary cam adjuster collar stopper screws. (The rotary cam slides to right.)
2. Take the clearance of 0.2—0.6 mm (TYP. 0.3 mm) between the rotary cam and the rotary cam adjuster collar, then fasten the two rotary cam adjuster collar stopper screws securely. (Fig. 6-3)

If the machine has not got a washer between the rotary cam adjuster collar and the rotary cam holder (R), the clearance must be 0.5—0.8 mm (TYP. 0.6 mm).

Note : When adjusting this item, the encoder board must be mounted.

3. After adjusting the relation between them, turn off the power switch and set the change knob to position "KC(II)".
4. Bring forward all the needles to position B.
5. Move the K carriage slowly, all the B position needles must be selected to position D.

- When the K carriage is hard to push, reduce the clearance between them to the proper spaces.
- When the needles do not come out to position D, enlarge the clearance between them to the proper spaces.

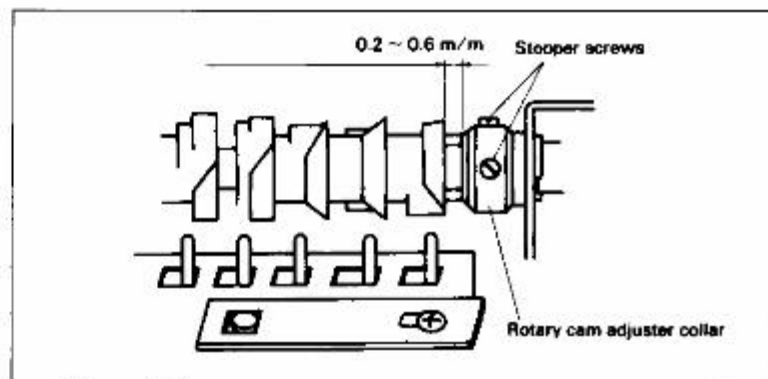

Fig. 6-3

VII CHECKING OF THE POWER SUPPLY SYSTEM

* AC section

WARNING : Testing AC section is dangerous and must be done only by qualified personnel.

Test the AC main outlet.

Use an appliances know to be working. eg. Reading lamp etc...

Test the main lead.

This should NOT be connected to supply for these tests.

Test the mains cord for continuity, if it is discontinuous, replace with a new one.

* United Kingdom and Ireland sepcification.

Test the fuse in the mains plug where fitted, and connections in the plug top.

** AC section consists of AC inlet, noise filter board, power switch and power transformer.

AC section reduces the voltage of the power supply of the wall outlet and supplies the reduced voltage to the power supply board.

AC section and the power supply board are connected to each other with connector S9.

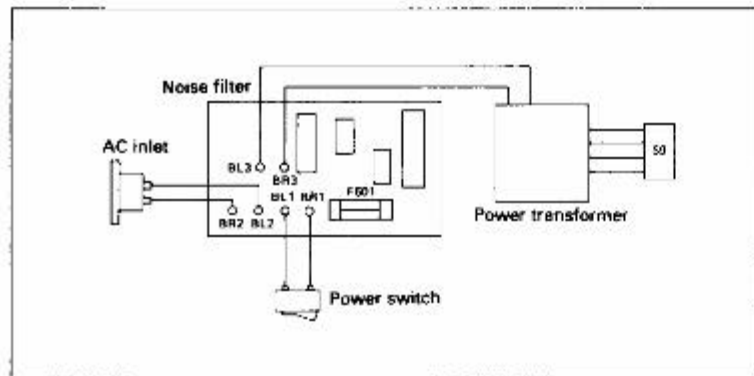

Fig. 7-1

* Checking the AC inlet. (The primary winding side of the power transformer)

- Pull out the power supply cord.
- Set the tester to the $\Omega \times 1$ range.
- Connect both terminals of the tester to both pins of the AC inlet.
- Turn on the power switch, the indicator of the tester should show 10 ohm.

CHECKING PROCEDURE OF POWER SUPPLY SYSTEM

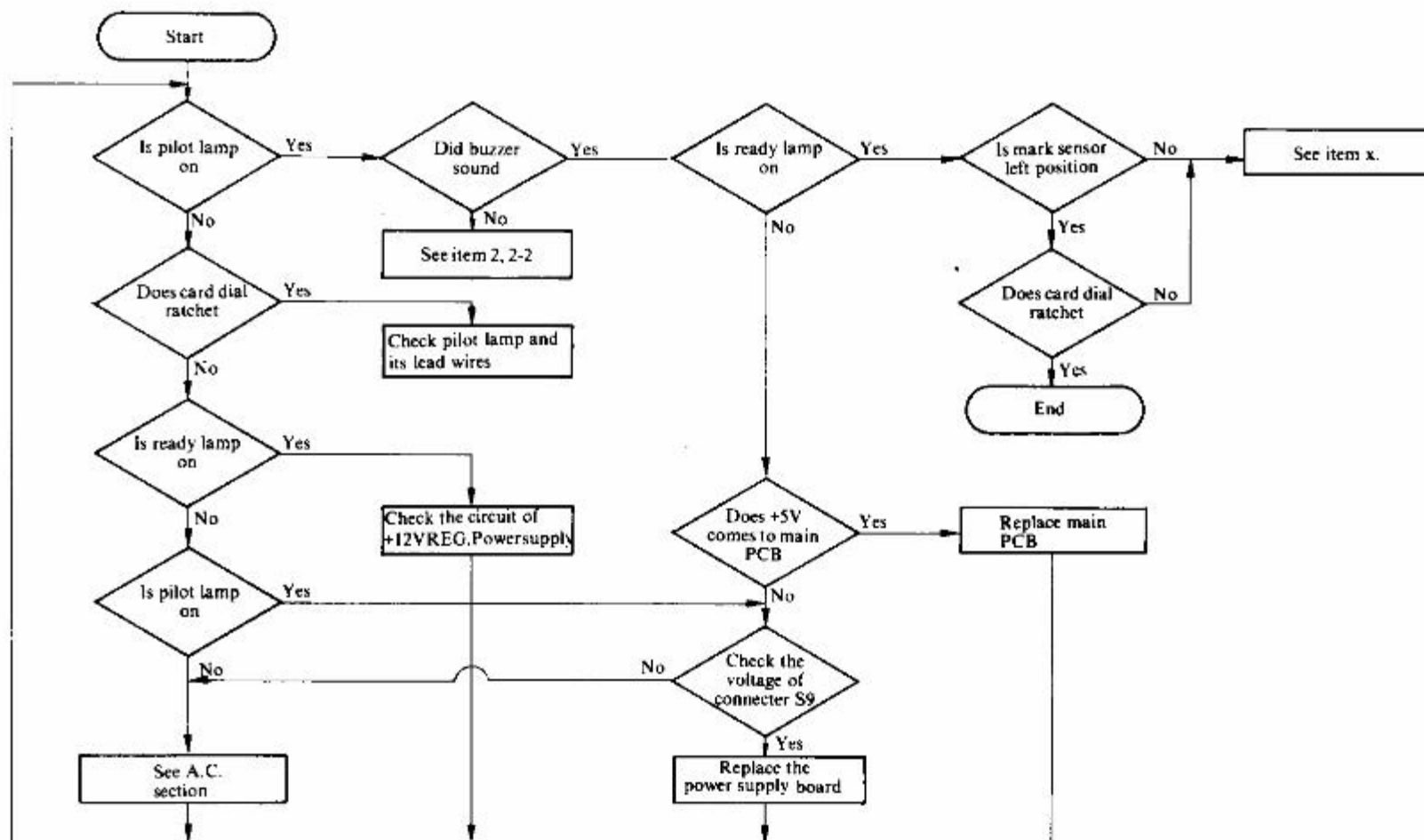

Fig. 7-2



Fig. 7-3

- * When the indicator shows 0 ohm, there is a short-circuit on the AC. input.
- * When it shows infinite (∞) ohm, the fuse (F601) is broken, the primary winding of the power transformer or the other cords on the AC. input are disconnected.

1. When the indicator shows infinite (∞) ohm:

1.1 Checking the fuse (F601).

- a. Disassemble the AC. section.
 1. Pull out the power cord from the AC. inlet.
 2. Remove the three screws for the needle bed and the three plastic rivets for the lower side plate (R) assembly.
 3. Remove the two screws for the AC. inlet.
 4. Take off the lower side plate (R) assembly.
 5. Remove the screw of the cord presser plate and take off the cord presser plate.
 6. Pull out the noise filter board.
- b. Check the fuse (F601) which is installed on the noise filter board. If it is broken, replace the fuse (F601) with a new one.
 - * After replacing the fuse, find and repair the cause of the defects. Then, turn on the power switch.

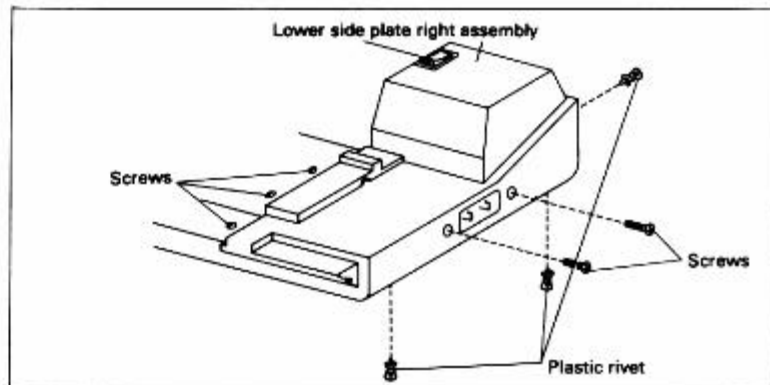

Fig. 7-4

1.2 Checking the primary winding of the power transformer.

- a. Set the tester to the $\Omega \times 1$ range.
- b. Check the resistance between both lead wires of the power transformer which is soldered at the position of BR3 and BL3 on the noise filter board.

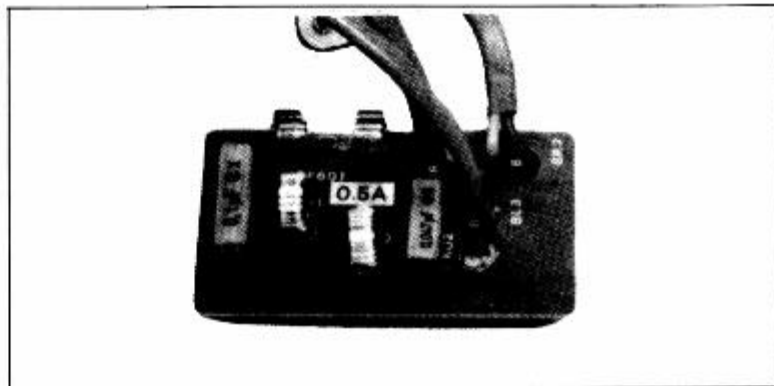

Fig. 7-5

- * If it shows 10 ohm, the primary winding of the power transformer is not disconnected.
- * If it shows infinite (∞) ohm, replace the power transformer with a new one.

1.3 Checking the noise filter board.

Check the resistance between the soldered face of BR1 and BR2.

- * If it shows 10 ohm, the noise filter board is working correctly.
- * If it shows infinite (∞) ohm, replace the noise filter board with a new one.

2. When the indicator shows 0 ohm:

2.1 Checking the primary winding of the power transformer.

- Disconnect one of the lead wires of the transformer which is soldered at the position of BR3 or BL3 on the noise filter board.
 - Check the resistance between both lead wires of the transformer by setting the tester to the $\Omega \times 1$.
- * If it shows 0 ohm, there is a short-circuit on the winding of the power transformer. Replace it with a new one.
 - * If it shows 10 ohm, it is working correctly.

2.2 Checking the noise filter board.

Checking the resistance between the soldered face of BR3 and BL3 after taking off the fuse (F601).

- * If it shows 0 ohm, replace the noise filter board with a new one.
- * If it shows infinite (∞) ohm, the noise filter board is working correctly.
- * Checking the AC. output. (The secondary winding side of the power transformer.

This transformer has two secondary windings which have the thermal fuses.

One of the secondary winding is for DC. 12V power supply, and its voltage is AC. $12.5V \pm 10\%$ at the two pins of the orange cords of the connector S9.

The other is for DC. 50 power supply, and its voltage is AC. $10.5V \pm 10\%$ at the two pins of the red cords of the connector S9.

- Pull out the connector S9 from the power supply board.
- Set the tester to the AC. 300V range, and connect the terminal of the tester to the pins of the connector S9.

- * Be careful so as not to deform the pins.

Refrain from inserting the test rod directly into S9 connector.

- Turn on the power switch after connecting the main cord to the inlet.

Check 5V power supply.

Measure the voltage between pin 3 and pin 4 of the connector S1 to check if the voltage will be $5V \pm 5\%$.

When the voltage measurement is 0V, check the fuse (F202) on the power supply board assembly.

- * If it is found burn out, replace it with a new one, and check the circuits which are worked by 5V power supply.
(See the old type service manual.)
- * If no fuse burning noticed, confirm the voltage at the two pins of red cords of the connector S9, and if no irregularity found, replace the power supply board assembly.

Check 12V regulated power supply.

The input to the 12V regulated power supply is 10 ~ 15V of the 12V power supply and the output of it is 10 ~ 12V, so that first of all, the 12V power supply should be confirmed on its correct functioning.

After that, take voltage measurement on the collector of transistor (0209) on the power supply board assembly.
(on transistor middle leg)

If the measured voltage is DC 10 ~ 12V, the 12V regulated power supply will be anticipated as functioning correctly to be fed to the pulse motor (for the card feeding) and to the power supply pilot lamp.

IX CHECKING THE NEEDLE POSITION DETECT CIRCUIT

1. Needle position detect circuit outline

The computer required to know the connecting relations between the carriage and the belt, and also to know the current position where the carriage is located, in order to discern when and which needle selector solenoid will be switched.

For that reason, this machine has left and right position sensors, rotary encoder, reader sensor of rotary encoder, belt phase detecting sensor and sensor magnet on each of the carriage.

1-1. The left and right position sensors

Each sensors are located at the left and right turn mark positions.

When the sensor magnet of the carriage comes onto the position sensor, it will be detected and discerned whichever N or S pole.

If it is detected by the left position sensor, the carriage position counter will be set 1, and if the right position sensor finds it, the carriage position counter will be 200. When N pole is detected, it is discerned as K carriage, and in case of S pole detection it will be L carriage, and if S pole is subsequently followed by N pole, G carriage will be discerned.

1-2. The rotary encoder

There are 48 pieces of comb teeth on the periphery and 3 teeth on the center for the belt phase signal, equipped on the rotary encoder.

The rotation of the rotary encoder will be once every 48 needle movement.

1-3. The reader sensor of the rotary encoder.

The function of this device is to read the number of comb tooth movement of the 48 teeth, and the sensor is composed of two sets of photo sensor in one body construction, the relative locations of the two sensors being a half of tooth breadth distance separated each other.

The signal issued from the above sensor is named VIDEO signal, and the one issued from a photo sensor is to be V1 signal and the other is to be V2 signal.

The computer can discern the displacement distance of the carriage by V1 signal, and the direction of the carriage movement by means of relations between the two video signals V1 and V2.

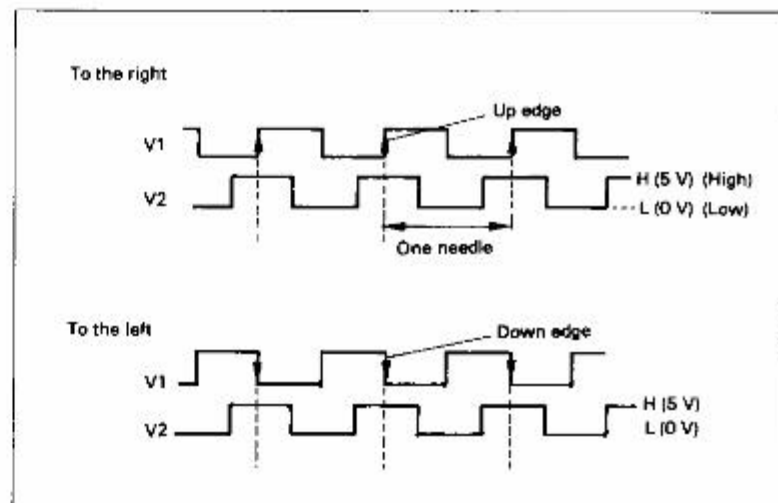

Fig. 8-1

When V1 signal rising up at V2 signal being located on H level, the computer will discern the carriage moving direction as right ward, and find out the left position sensor signal.

If the signal is H, the computer reset the carriage position counter on 1, and also determines the solenoid number to be controlled by means of investigating of the belt phase signal.

If the left position sensor signal is L, the carriage position counter and the solenoid number will be increased by 1.

In the like manner, when V1 signal coming down at a moment of V2 on H, the carriage moving direction will be discerned as left ward, so that the right position sensor signal will be investigated, and if it is on H, the carriage position counter will be reset on 200, the belt phase signal being investigated to determine the solenoid number, if the right position sensor signal is on L, the carriage position counter and solenoid number will be decreased by 1.

2. Under the checking procedure 4, in case of the difference between the carriage position and the indication number is more than 1.

It shows that the left or right position sensor is not correct.

2-1. Output voltages issued from the left and right position sensors

The left and right position sensors are magnetic sensors, the output of the left position sensor being so adjusted as to be $1.6V \pm 0.05$ in voltage signal when the carriage sensor magnet is not located in front of the sensor and the output of the right position sensor should be 1.80 ± 0.05 . And also both sensors being so adjusted as to be increased gradually as the N pole of the sensor magnet coming nearer to the front of the sensor up to over 2.75V, where the position signal will be issued, and to be decreased as the S pole approaches up to lower than 0.65V, where the position signal will be issued.

2-2. The right position sensor adjustment

- 1) Take away the carriage magnet from the sensor front, the needle selector panel being removed.
- 2) The power switch being on, check the voltage on check pin CH301 on the encoder board assembly, if the measurement shows $1.8V \pm 0.05$, it will be correct.

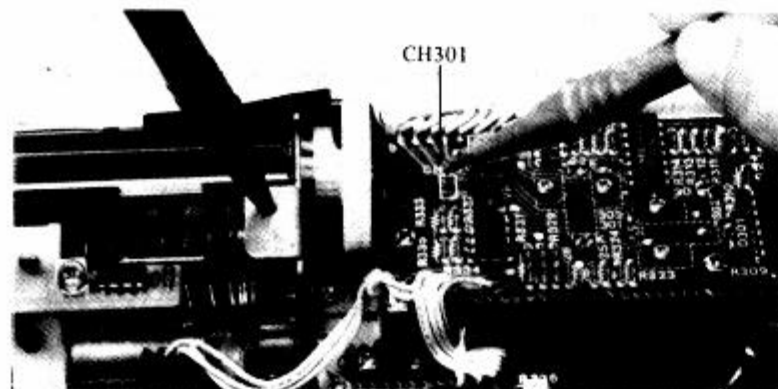

Fig. 8-2

- 3) If the measurement shows incorrect voltage, turn VR301 to adjust the voltage on 1.8V.
 - If it is not available to adjust the voltage on 1.8V, replace the encoder board assembly.

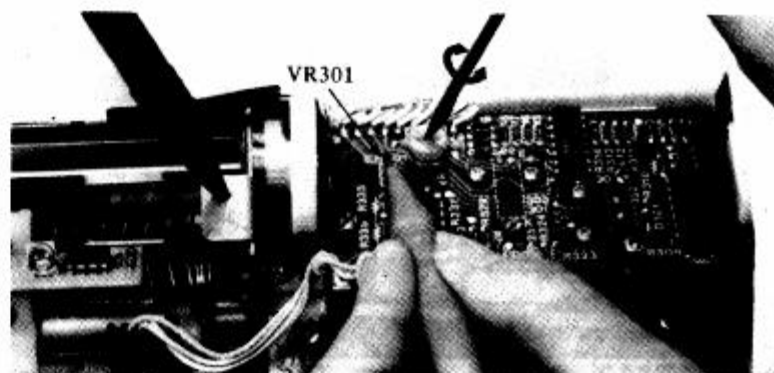

Fig. 8-3

- 4) Place the L carriage magnet in front of the sensor, and check the voltage on CH301, it should be 0.4V or less; confirm the voltage should be 3.4V or more, when the magnet approaches in front of the sensor, where the change knob turned on Mark KCI or KCII on K carriage; and the voltage should be 2.6V or less, when the knob turned on Mark N.L.; if the above voltages are not obtained, there must be some irregularities such as incorrect locations of sensor magnets on K carriage or L carriage, unsuitable alignment of the sensor board assembly high or low, forward or backward, etc.

2-3. The left position sensor adjustment

Left position sensor adjustment

- 1) Take away the carriage sensor magnet from the sensor front, removing the needle selector panel, row counter panel and the operation panel, where the connectors being not disconnected from the operation panel, the panel will be placed on the rear side of the machine body without the board touching carelessly on the metal part.

- 2) Power switch on, then check the voltage on the check pin CH401 of the left position sensor board assembly if the measurement shows a voltage in a range of $1.6V \pm 0.05$, there must be no problems.

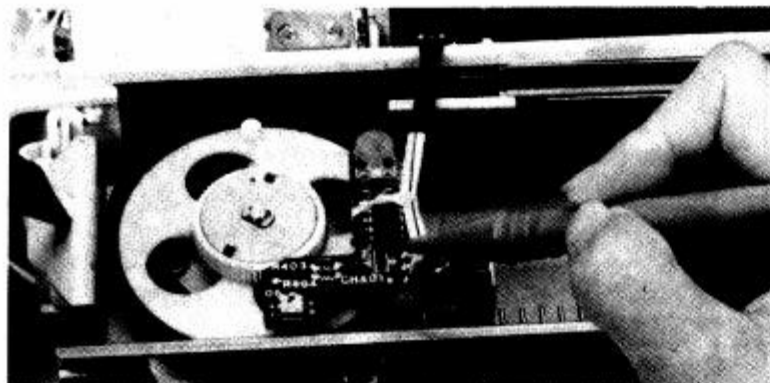

Fig. 8-4

- 3) If the voltage measurement is not correct, turn VR401 and adjust the voltage on $1.6V \pm 0.05$.
- * If it is not available to adjust the voltage on $1.6V$, replace the left position sensor board assembly.
- 4) Place the L carriage magnet in front of the sensor, and check the voltage on CH401, it should be $0.4V$ or less; confirm the voltage should be $3.4V$ or more, when the magnet approaches in front of the sensor, where the change knob turned on mark KCI. KCII on the K carriage; and voltage should be $2.6V$ or less, when the knob turned on mark N.L.; if the above voltages are not obtained, there must be some irregularities such as incorrect locations of sensor magnets on K or L carriages, unsuitable alignment of the sensor board assembly high or low, forward or backward, etc.

2-4. Mounting left and right position sensor.

Both left and right position sensor board must be mounted in parallel with the rear rail of machine bed.

It can not output correctly for G-carriage if the position sensor board is leaning and it is far from the sensor magnet of carriage.

Left position sensor can be adjusted with the setting hole of the sensor board by moving it to right or left.

In case of KH-910 Slide the left position sensor board to the left and mount it securely.

In case of modified KH-910 Slide the left position sensor board to the right and mount it securely.

If it does not mount correctly, needle selection will be slidden for eight needles to right or left.

3. In case the carriage position does not indicated in the display by checking procedure No. 4.

If the sensor magnet of carriage is mounted correctly, there are some defects on the position sensor signal or encoder signal V1/V2.

Check the needle position detect circuit by referring to the test programm 885.

3-1. When the error lamp is lit up and the digits appears in the display after entering 885 and push M key.

It shows some output of right/left position signal are made when there is no magnet sensor of carriage in front of left/right turn mark.

The first digit (right) shows the informations of the right turn mark, and second digit (left) indicates the informations of the left turn mark.

FIRST DIGIT (RIGHT)

- 0 : No signal
- 1 : K carriage signal
- 2 : L carriage signal

SECOND DIGIT (LEFT)

- OFF : No signal
- 1 : K carriage signal
- 2 : L carriage signal

The computer detect errors and display the errors as the digit.

(EXAMPLE)

ERROR NUMBER (DIGIT)

- 1 : Right turn mark signal for K carriage
- 2 : Right turn mark signal for L carriage
- 10 : Left turn mark signal for K carriage
- 20 : Left turn mark signal for L carriage
- 11 : Right and left turn mark signal for K carriage
- 22 : Right and left turn mark signal for L carriage
- 12 : Left turn mark signal for K carriage and right turn mark signal for L carriage
- 21 : Right turn mark signal for K carriage and left turn mark signal for L carriage

- 3-2. If the error lamp is lit up when passing the carriage to the turn mark.
- 1) If the number 4, 5 or 6 is displayed, there are some defects on the rotary encoder gear or encoder P.C.B.
If there is no defects on the rotary encoder gear, replace the encoder P.C.B. with the new one.
 - 2) If the number 7 is displayed.
Right or left position sensor is not mounted correctly.

- 3-3. If the ready lamp is lit up when passing the carriage to the turn mark.
Two digits will be indicated in the display.
First digit (right) shows the condition of B.P. signal and second digit (left) indicates the type of carriage.

B.P. SIGNAL (1ST DIGIT)	TYPE OF CARRIAGE (2ND DIGIT)
0 : "L" range	1 : K carriage
1 : "H" range	2 : L carriage
	3 : G carriage

If the indication of the display does not correspond to the carriage, check the face of magnet sensor of carriage and it must be as follows:

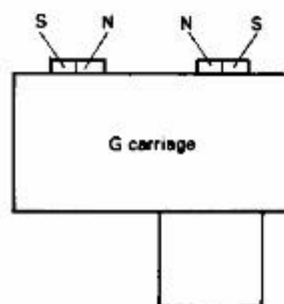

K carriage "N"
L carriage "S"
G carriage "refer to the diagram."

If there is no defects, check it again after sliding the carriage for eight needles to the right or left. (Slide the connecting plate of carriage to the next hole of the timing belt.)
If the second digit (left) is changed (0 → 1, 1 → 0), it is working correctly.
If it does not change, replace the encoder P.C.B. with the new one.
It is cause of the wrong needle selection. (Needle selection slides for eight needles to the right or left.)

IX CHECKING THE NEEDLE SELECTOR SOLENOID

1. Needle selector solenoid outline

The needle selector solenoid functions to control the rotary cam lever and the rotary cam, in that energized solenoid will make the rotary cam lever remove from the rotary cam, and the needle placed on position B, and the solenoid not energized will make the rotary cam lever or and rotary cam coupled together, to drive the needle selector plate to select the plain needle on position D.

The pulling force of the solenoid is 260g or more, when the movable pie (armature) and the iron core are in contact, and is about 709, when the above two are separated with 0.5 mm gap; on the other hand, the rotary cam lever is held by flat spring, the lifting force of which is about 120g; consequently the needle selector solenoid itself will not be able to remove the rotary cam lever from the rotary cam, so that the rotary cam lever can maintain its position under the condition that the rotary cam depressing the rotary cam lever, the armature is able to contact the iron core.

The relations between the armature and rotary cam lever are shown on the diagram given below:

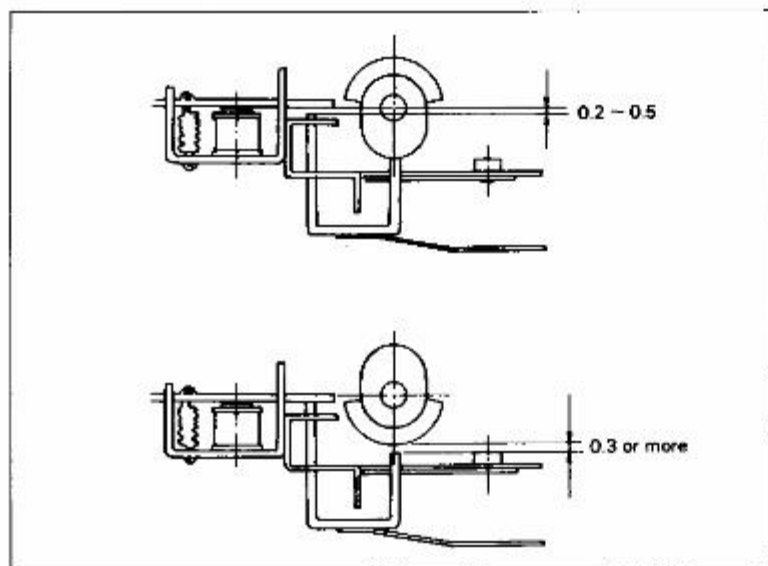

Fig. 9-1

2. Relations concerning: Needle selector solenoid (Rotary cam), Needle selector plate, Belt phase, and Needle number

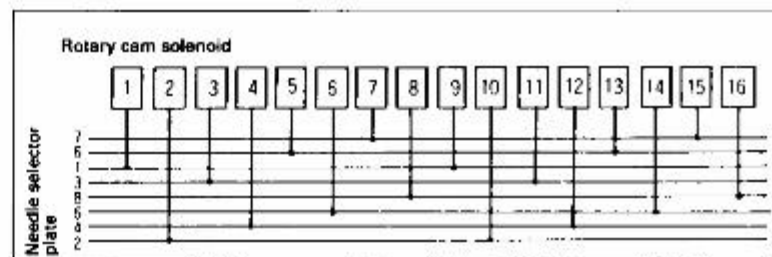

Fig. 9-2

2-1. Belt phase

There are laterally elongated holes and circular holes provided on the belt, the former being placed by the carriage connecting hock, the pitch of which is eight plain needle length.

The rotary cam will rotate one round per every 16 pitch displacement of the carriage, in which the N.S.P. will complete two return trips of itself. Taking an example of N.S.P. 1, it is driven by rotary cams 1 and 9, which are located 180° phase angle separated on their cam positions, so that after cam 1 completes one cycle drive of the N.S.P., subsequently cam 9 will repeat another cycle drive of the N.S.P.

Associated with the fact that the pitch of the laterally elongated holes is 8 pitch, the cam which is ready to drive the N.S.P. may be either No. 1 or No. 9 regarding the coupling position of the carriage and belt, even if the carriage is located of at the same position against the needle bed.

Resultingly in order for the computer to control the needle selector solenoid drive, it is required to know the relative relations between the belt and carriage, so that it is so arranged as to generate the necessary signal by means of the rotary encoder function, and this signal is referred to as Belt phase signal.

The computer will determine for each of the plain needles the number of needle selector solenoid by checking the belt phase signal received when the carriage comes on the left position sensor (◯) or on the right position sensor (◻).

2-2. Needle selector plate, Rotary cam and Needle number

Belt phase																	
L	H	K carriage at left position															
H	L	K carriage at right position															
H	L	L carriage at left position															
H	L	L carriage at right position															
N.S.P.	Sol.	Yellow needle no.								Green needle no.							
1	1 9	100	84	68	52	36	20	4	13	29	45	61	77	93			
2	2 10	99	83	67	51	35	19	3	14	30	46	62	78	94			
3	3 11	98	82	66	50	34	18	2	15	31	47	63	79	95			
4	4 12	97	81	65	49	33	17	1	16	32	48	64	80	96			
5	5 13	96	80	64	48	32	16	1	17	33	49	65	81	97			
6	6 14	95	79	63	47	31	15	2	18	34	50	66	82	98			
7	7 15	94	78	62	46	30	14	3	19	35	51	67	83	99			
8	8 16	93	77	61	45	29	13	4	20	36	52	68	84	100			
1	9 1	92	76	60	44	28	12	5	21	37	53	69	85				
2	10 2	91	75	59	43	27	11	6	22	38	54	70	86				
3	11 3	90	74	58	42	26	10	7	23	39	55	71	87				
4	12 4	89	73	57	41	25	9	8	24	40	56	72	88				
5	13 5	88	72	56	40	24	8	9	25	41	57	73	89				
6	14 6	87	71	55	39	23	7	10	26	42	58	74	90				
7	15 7	86	70	54	38	22	6	11	27	43	59	75	91				
8	16 8	85	69	53	37	21	5	12	28	44	60	76	92				

*N.S.P. = Needle selector plate
*Sol. = Needle selector solenoid

Fig. 9-3

3. Checking the needle selector solenoid

In case where there are some needles selected on position D under the checking procedure 5.1.

3-1. Removing the Needle Selector Panel, and find out the Needle Selector Solenoid armatures in functioning by means of driving the carriages:

There should be 16 pieces of armatures noticed in the space between the pattern card outlet on the card reader unit and the case; the connectors on the needle selector solenoid are S2 and S3, in that pin 9 and pin 10 on S2 are energized by 120 power supply line, each of other pins corresponds each of the solenoids respectively.

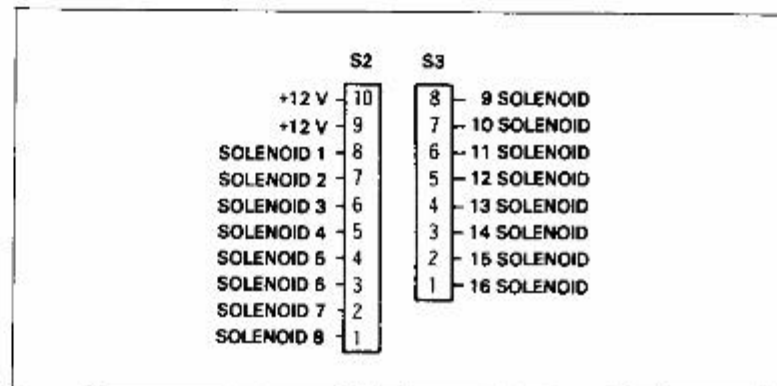

Fig. 9-4

Take a resistance measurement between pin 10 or pin 9 on connector S2 and one of the pins which are under functioning.

Take a resistance measurement between pin 10 or pin 9 on connector S2 and one of the pins which are under functioning, and check the result:

If the measurement shows the resistance value of 140 ~ 150Ω, it has no problems; and if the solenoid side is normal and some malfunctionings found, there should be some irregularities on the control circuit, so that the main PC board assembly should be replaced.

3-2. In case some irregularity anticipated in the checking of connectors S1 and S2

There must be some defects such as breaking of the solenoid signal cord, or poor soldering, and breaking of solenoid cord, or poor soldering, so that the needle bed should be removed from the carrying case lower assembly; the solenoid board is found on the rear side of the bottom of the card reader unit, referring to the illustration given below, check the resistance on the solenoid coil, and lead wire, to find out breaking of wire or poor soldering, etc.

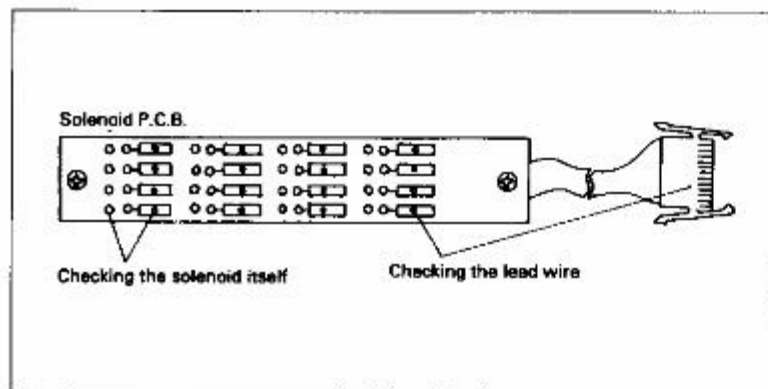
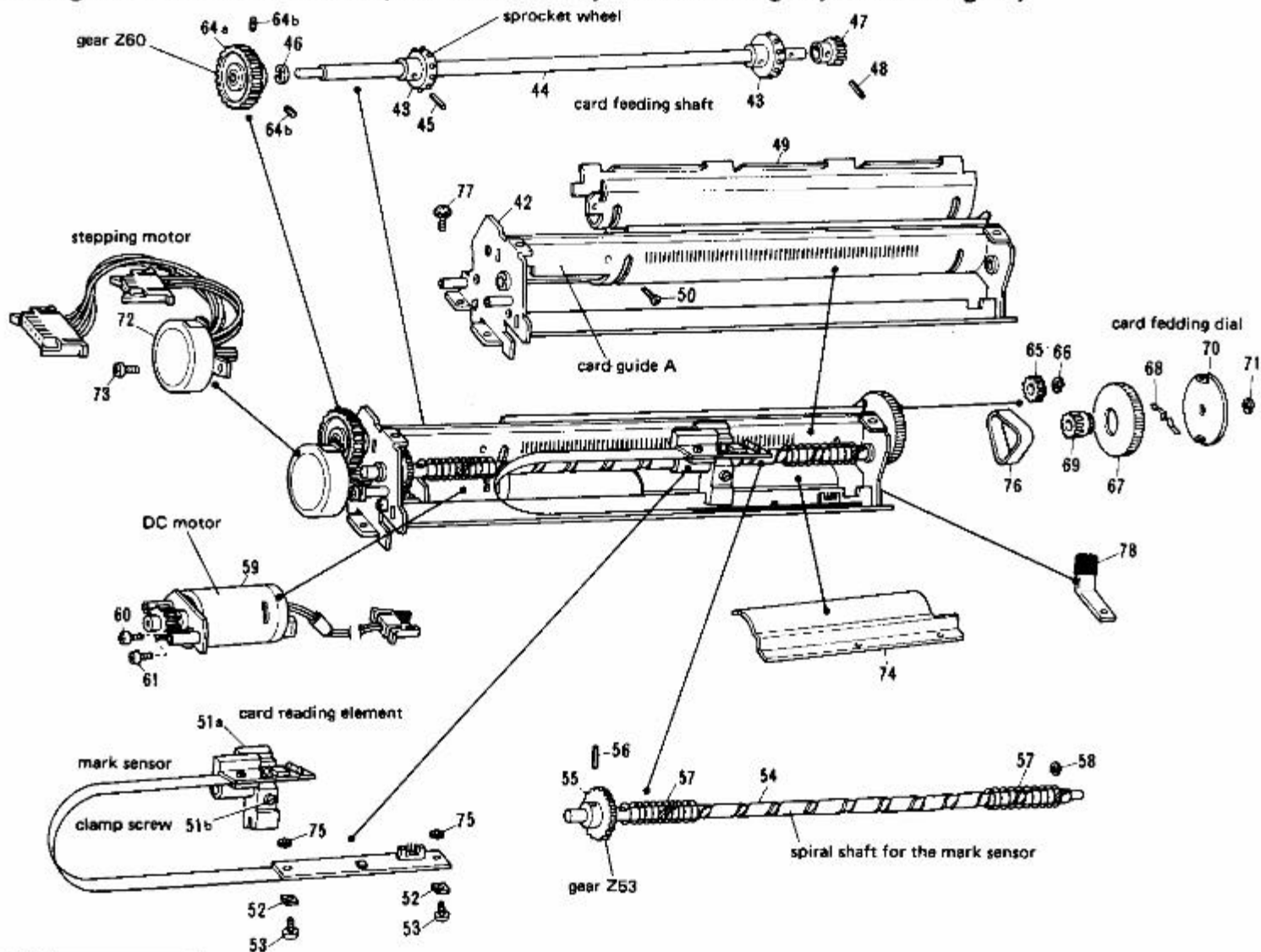

Fig. 9-5

X CHECK AND ADJUSTMENT OF THE CARD READER

1) Exploded diagram for the card reader (Please order the parts according to parts catalogue.)



2) Card reader unit outline

2-1. Card Feeding

The pattern cards will be fed by the pulse motor; the pulse motor is driven by a particular speed of rotation responding to the number of pulses of the input signal;

In this particular case, the pulse motor currently applied is so constructed that it rotates with a speed of rotation in which one round will complete every 24 pulses received of the input signal; and in addition accessories such as the pulse motor gear, Z60 gear, and card feeding sprocket are so arranged as for the pulse motor to feed one line of the pattern cards by a rotation corresponding to 4 input signal pulses.

Resultingly one round of the pulse motor can feed 6 lines of the Pattern Card, the stopping position being specified. If the power supply being cut off, it is attempted to transmit the Card's by means of manual rotation of the pulse motor by turning the card feeding dial, the motor will take a stopping position different from 6 locations specified as stopping positions, however when the power supply is ON, the pulse motor will rack the nearest position among those specified by automatically resumed rotation, the above is the reason why cards tend to move a little bit, when the power switch is turned on.

The pulse motor in current use is a four phase pulse motor having four coils, and the motor will be driven by energizing these four coils subsequently one by one. The lead wires are coloured in brown, red, orange, and yellow respectively responding to coil 1, coil 2, coil 3, and coil 4; other 2 black wires are 12 V power supply lines.

A excitation type in that motor driving force is obtained by a rotating magnetic field which is obtained by energizing two coils among the four invariably, and by changing the combination of the two coils, is referred to as two excitation type.

In this case, while the pulse motor stops, coil 3 and coil 4 are energized, and the four coils will be energized sequentially along with input pulses as shown below:

stop	(1 pulse)	(2 pulse)	(3 pulse)	(4 pulse)	stop,
3.4	---4.1	---1.2	---2.3	---3.4	

and one revolution will be completed to feed one line of the pattern card.

2-2. Card Reading

The pattern card will be read in by means of ultra red reflection type sensor, in that the sensor is driven from left to right or right to left along with the direction of rotation, whether normal or reversed, of the DC motor, to sense the line of pattern to be read in.

The sensor will take reading once every cycle of the carriage turn, and even if no card feeding is available in the case of the double length switch of KRC switch being provided, it will read twice on the line for reading in.

The reflection type sensor consists of an ultra red light emission diode (LED) and photo transistor, the relative position is in such a way as LED being placed under, and the photo transistor on the top; the ultra red ray emitted from LED will pass through every layer of surface of the card guide A (metal surface), white surface of card, and black surface of card, being reflected from every layer into photo transistor.

The black part of the card is printed in an ink easily absorbing ultra red ray so that the ray emitted into the transistor is rather weak, besides the above an attached marker for special uses for the blank card is also the one which the Ultra red ray effectively, excepting those, the usual ink or pencils, sign pens or magic ink can not absorb Ultra Red Rays at all. Through the white part of the card, ultra red ray will partially be reflected on the surface, and the remaining will penetrate the card, proceeding to the card guide plate internal (reflector), then reflected on the card guide plate surface, again penetrates through the card to reach the photo transistor, the amount of the reflected ray returning to the photo transistor is smaller than those coming from the card guide A, but larger than that returning from the black part.

The photo transistor output varies depending upon the amount of ray received there on, and the output will be amplified through amplifier. The IC provided on the sensor board is an amplifier, the amplification factor of which is adjustable by means of variable resistor VR501.

When card reading is undertaken, the amplifier output voltage, i.e., the voltage of check pin CH501 will be so adjusted as to maintain the voltage 2.0 ~ 3.0V.

Operating upon the surface status of the card or reflector, the reflection coefficient will differ, so that a specially prepared card is used for the

purpose of level adjustment; in that any kind of card can be applied for the reading without spoiling the output voltage on the white part of the card, (referred to as white level) which is to be maintained at 2.0~3.0V; the output voltage (referred to as clock level) reflecting from the card guide A is 3.4V or more, and the output voltage (black level) from the black part reflection of the card is less than 0.6V in the case of usual printed card.

The output of amplifier will be separated into clock signal and data signal, by means of a comparator and other circuitries. so that the computer will pick up the down edge (transferring from H level to L level) of the clock signal to take in data signal, counting the clock signal up to 60 in the number, then the reading out will be stopped.

If the card guide is adhered by oil or dust etc., and the output voltage is lowered than the level of 3.3V, it will evolve excess issuance of the clock signal in amount of 1, so that the data read out henceforth will be shifted 1 column. If the card gets dirty, the white level is lowered than 1.4V, (converted into black) or higher than 3.3V (no clock avails), or if the black level gets higher than 1.4V, it will originate the misreading.

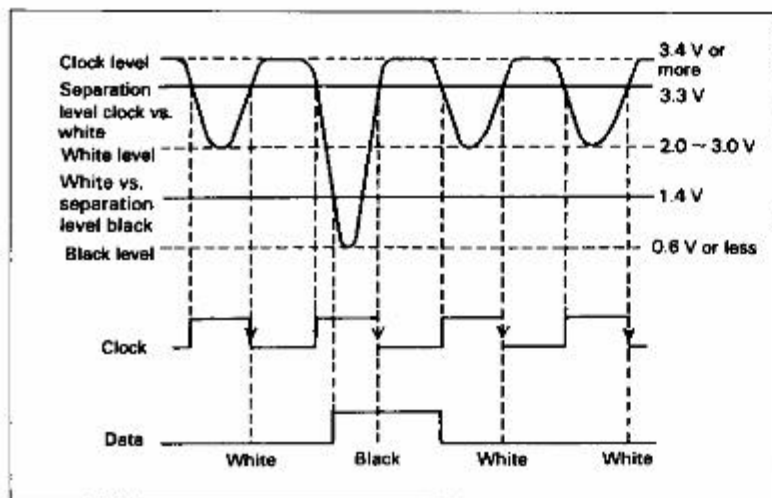

Fig. 10-1

3) When the ERROR lamp lights and the error No. is indicated in the Test 881.

3-1. When the error No. 1 is indicated

If the mark sensor does not move or it can not read even one stitch, ERROR No. 1 will be indicated.

• Push the M key to continue the test after removing the needle selector panel and check the movement of the mark sensor.

If the mark sensor does not move, refer to the "Checking the mark sensor drive".

• When the mark sensor can move, there is any defect on the mark sensor the encoder board assembly, the main P.C. board assembly or miscontact between the connector S5 and P5.

1) Check of the mark sensor

Take a voltage measurement on check pin CH501.

Turn the gear 253 on the spiral shaft for the mark sensor and check the voltages of white, black and clock levels, if the measurement shows white level: 2.0 ~ 3.0V, black level: 1.00 or less and clock level: 3.4V or more, the card reading is correct.

If there are some difects, adjust the VR501. (Refer to "6.3 Adjustment after the mark sensor replaced")

If it is not able to adjust VR501, replace the mark sensor.

2) In case that the mark sensor is correct.

Check the connection between the connector S10 and its soldering joint on the encoder board assembly, and also between the connector S5 and its soldering joint.

If there is no disconnection, replace the pattern case whole unit and check the card reader unit by Test 881 again.

After that checking, if the error lamp lights, replace the encoder board assembly.

3-2. When the error No. 2 is indicated

It means that the mark sensor can not read up to 60 stitches on the pattern card.

If the card gets dirty and/or if the card guide A is adhered by oil or dust etc., the mark sensor can not read up to 60 stitches, so replace the card and wipe out oil on surface of the card guide by cloth with alcohol.

3-3. When the error No. 3 is indicated.

Four stitches from stitch No. 1 to 4 of the row number 1, 2, 137 and 138 of the pattern card No. 1 are memorized into memory by the computer, so that the computer can compare the memorize data and read data, and if the read data is wrong, the error No. 3 is indicated.

Causes

- 1) The card is not fed, then the mark sensor read the lower position of the card.
Refer to "Checking the card feeding"
- 2) The set line is not fitted in the card inlet, then the mark sensor read another row.
Check the set line on the card inlet, if it is fitted in the card inlet, it means that vertical position of the sensor is not proper.
Adjust the sensor position by referring to "6.3 Adjustment after the mark sensor is replaced."
- 3) Adjustment at the level of the sensor is not proper.
Adjust VR501 by referring to 6.3 Adjustment after the mark sensor replaced."

4) Checking the card feed

4-1. Checking the card feeding mechanism

When turning on the power switch, the card dial does not move the card feeding shaft because it has an overload clutch mechanism.
Turn off the power switch and feed the pattern card by turning the card feeding dial.
If the card feeding dial ratchets there are some defects on the card feeding mechanism.
The encoder cords are fouling the card feeding dial or the gear Z60.
The gear for the stepping motor and the gear Z60 are engaged too tight. (Fig. 10-2)

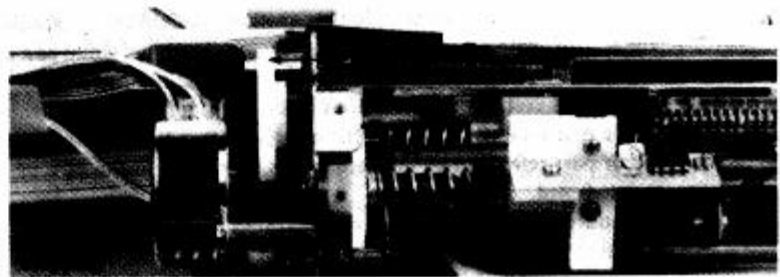

Fig. 10-2

Adjust the engagement of both gears by moving the gear Z60 to right and left.

Take the smallest play between both of them and the card feeding shaft must move smoothly.

4-2. Checking the stepping motor

The coils of the stepping motor are connected to the connector S4 as show in the figure. (Fig. 10-3)

Set the teter to the $\Omega \times 1$ range and check the resistance of each coils as following condition.

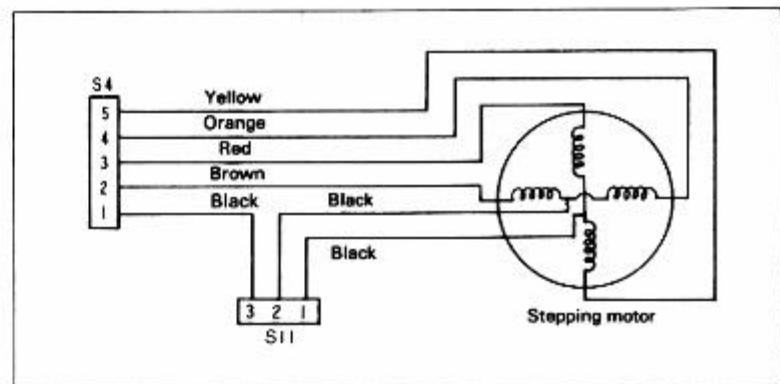

Fig. 10-3

S11 No. 1 pin — S4 No. 3 pin/No. 5 pin.

S11 No. 2 pin — S4 No. 2 pin/No. 4 pin.

The indicator of the tester shows 50Ω — 70Ω .

If the stepping motor is working correctly, there are some defects on the control circuit.

Replace the pattern case whole unit or the main P.C.B. assembly with a new one.

5) Checking the mark sensor drive

5-1. In the case, where an inspection under no power supply found heavy turning of gear Z53 which drove the spiral shaft for mark sensor.

- (1) Skid resistance between the sensor frame and spiral shaft is higher depending upon the oil shortage on the spiral shaft.
- (2) Oil on the spiral shaft is solidified by means of dust or dirt, etc.
- (3) The sensor clamp screw is loosened, and stranded over the spiral shaft slot.
- (4) Excess tightening of the clamp screw causes contact on the shaft slot base.
- (5) Poor gear coupling evolved by tilting of DC motor fixing shaft or incorrect mounting of the DC motor on the fixing shaft.
- (6) The mark sensor contacts on the surface of the card guide A.
- (7) Coupling of the sensor frame and sensor guide plate is too tight.

The above cited statuses may be taken in mind.

5-2. DC motor rotation is not available.

- (1) Check on fuse, F201 mounted on the power supply board assembly: if fuse blown out is found, replace it with glass tube fuse: 0.8A, $\phi 5.2 \times 20$ (410337001)

* Inspection after the fuse replaced

1. Set the circuit tester on the resistance measurement range ($\Omega \times 1$), and connect the red testing rod on the machine body metallic port;
2. Place the black testing rod on the grip of fuse F201, then confirm the measurement does not indicate 0Ω ;

3. Place the black testing rod on the center of the three legs of each of four transistors Q201, Q202, Q203 and Q204 which are mounted on the heat sink plate in front of F201, and check the resistance between the two testing rod; if it is confirmed wheresoever exists no zero Ω measurement, there is no problem, and if any zero Ω is found on some of the transistors, the power supply board assembly should be replaced.

4. Remove connector S8 from power supply board assembly and the black test rod is connected on either Pin 1 or Pin 2, if the resistance measurement indicates 0Ω , first check if any part, e.g., the lead wires of the capacitor mounted on the DC motor terminal contacts other metal part.

In the case no irregularity being observed in the above, there should be some troubles inside the motor, so that the DC motor should be replaced.

- (2) Check the DC motor.

Take resistance measurements on P1, and P2 of connector S8, if the measurement indicates $15 \sim 20\Omega$, the DC motor should have no irregularities.

- (3) Check the DC motor control signal.

Remove connector S6 from the main P.C. board assembly and power switch should be 'ON'.

(Notice)

When power supply is to be ON, it should be duly confirmed beforehand that there are no contact existing between the main P.C. board assembly and other metal parts such as the case hanger, knit reader support etc; and also during the following inspection the main P.C. board assembly should be handled with due care not to contact with any other metal part because short circuit between the main P.C. board assembly and other metal parts often evolves computer or other I.C.s mounted on the main P.C. board assembly break down.

Measure the voltage on pins 6, 7, and 8 on connector P6 of the main P.C. board assembly.

If it is confirmed that the voltage on Pin 6: 5V, Pin 7: 0V, and Pin 8: 5V, they are in normal conditions.

(Reference)

- When mark sensor is stopping at left side:

The voltage on Pin 6: 5V; Pin 7: 0V; Pin 8: 5V

- When mark sensor is stopping at right side:

The voltage on Pin 6: 0V; Pin 7: 5V; Pin 8: 5V

- When mark sensor is running on the way from left to right:

The voltage on Pin 6: 0V; Pin 7: 5V; Pin 8: 0V

- When mark sensor is running on the way from right to left:

The voltage on Pin 6: 5V; Pin 7: 0V; Pin 8: 0V

When power switch is on, the computer will output the signal to run the mark sensor from right to left for 200 m/s, and subsequently it will issue the signal to stop the mark sensor at left side.

- (4) If there are no irregularity observed both on the DC motor and control signal on the main P.C. board assembly, there should be some trouble on the DC motor drive circuit on the power supply board assembly to hinder the DC motor running, so that the power supply board assembly should be replaced.

6) Card reader adjustment

6-1. As explained in the article 2.2 'Card reading', the mark sensor will pick up and read three kinds of reflecting rays to discern the white, black and clock.

When adjustment of amplification factor (VR501 adjustment) of the amplifier on the mark sensor is not correct, or the locations of the card and sensor are not in conformity with each other so that the sensor will pick up to read the portion bridging over the two lines of the card, the white or black level against the card is not to be the suited level, resulting a misreading of the card.

To amend this irregularity, taking the voltage measurement on check pin CH501, turn the gear Z53 on the spiral shaft and check the voltages of white and black levels; if the measurement shows white level: 2.0 ~ 3.0V, and black level: 1.0V or less, the card reading will be correct.

In this case, however, imparities between the card and sensor on their relative positions back and forth and up and down are unavoidable stranks to the idlings of the sensor holder and card feeding etc., and consequently after the level adjustment or level confirmation is

completed, rectification of the relative movement between the card and sensor should be conducted duly by means of pattern variation switch "double length" and "reflection", where resultingly the relative movement between the card and sensor should be so rectified that it should be confirmed that correct reading is invariably maintained whichever direction the sensor moves rightward or leftward on the card feed from up to down or down to up, where the reading runs invariably tracing the same line on the same card.

6-2. The way to fit the card portion after the pulse motor is removed or exchanged

- (1) The card reader being placed on the machine body, the connectors once removed will be connected to each of the places respectively, (S4, S11, S8 and S10)
- (2) Remove Fuse F201 on the power supply board assembly, the DC motor being kept unmovable.

(Notice)

Fuse (F201) should be invariably removed, when DC motor is kept unmovable for the test, because energizing the DC motor drive circuit on the power supply board assembly connector S8 being removed, after causes the circuit break down.

- (3) Loosen the stopper screw on the gear Z60.
- (4) Insert the pattern card No. 1, and feed the cards by card feed dial operation up to the extent where the card set line will meet the bottom of the card guide A window.
- (5) Connect the power supply cord, and let the power switch be ON, gear Z53 on the spiral shaft for mark sensor being turned to transfer the sensor to the left side of the card guide, and let the sensor read out on the metal surface of the left side of card guide A.
- (6) Check the voltage on check pin (CH501) by means of the circuit tester; the level on the reflector surface of the card guide should be 3.4V or more.

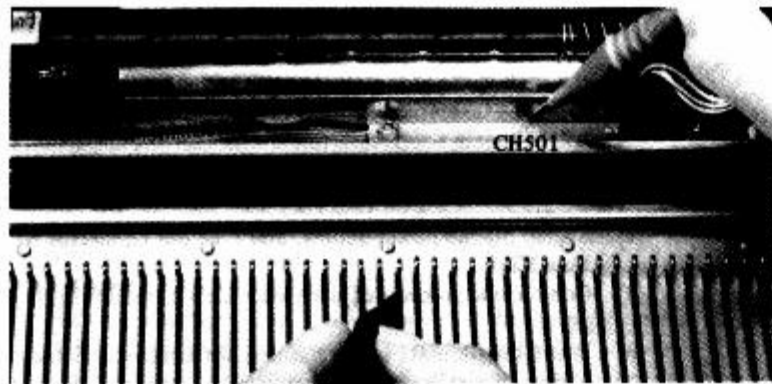

Fig. 10-4

- (7) Turn gear Z53 to this side slowly with invariably checking the tester indication, and find out the position where the tester indication will be the minimum (1.7 ~ 3.0V); at that time, the sensor should be reading on the center of the first reading window.
- (8) Holding the mark sensor position unmoved, turn the card feeding dial to this side slowly and find out the position where the tester indicates the minimum voltage (0.5 ~ 1.0V); at the position gear Z60 should be fixed by fixing screw, where the tester indication should invariably be checked to maintain the minimum voltage position without slipping out, i.e., the minimum voltage will be obtained where the lower line of the first column of pattern card will mostly meet the bottom edge of the card A window, in that the mark sensor will read out the first black mark on the second line.

6-3. Adjustment after the mark sensor replaced

- (1) Insert the special card for level checking into the card guide, and place the card frame and the reading window in conformity with each other.
- (2) Referring to article 6.2 item (7), put the sensor at the center of the card guide A window, where the window is not necessarily No. 1 window.

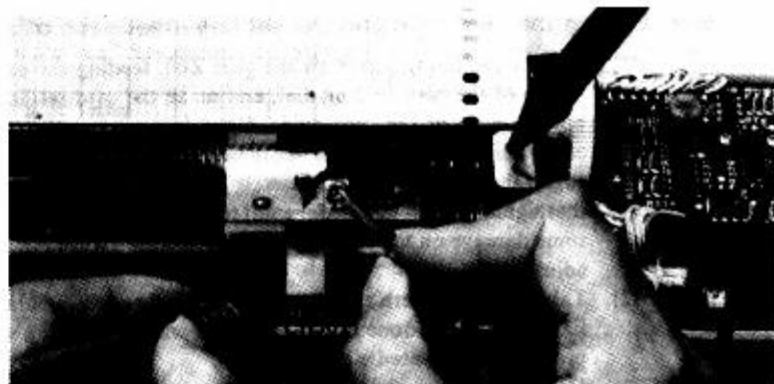

Fig. 10-5

If output of CH501 does not change, for the sake of unfinished adjustment on VR501 which is the trimmer for sensor adjustment, turn the VR501 counterclockwise a little to let the CH501 be changeable.

- (3) After the mark sensor being placed on the center of the reading window, adjust VR501 so as to meet the value specified on the special card, then fix the screw lock.

(Notice)

The screw should be fixed on a position separated from the trimmer resistor face and its sliding contact as far as possible, and care should be paid for the screw lock not to touch with the sliding contact, which evolves poor contact of the trimmer.

- (4) Applying the pattern card No. 1, check the columns on the card and the sensor reading stance are in a correct relation, referring to article 6.1; if they are not in the correct relation, adjust the position of the card, referring to article 6.2.

6-4. Letting the card inlet and the set line meet each other

- (1) Loosen the fixing screw on the gear Z60, feeding the card by means of the card feeding dial, and make the card set line and bottom edge of the card guide A window meet each other in conformity, (so as for the set line to be seen on the window bottom edge); then tighten the fixing screw on gear Z60 temporarily, in that tightening should be done not too tightly, avoiding to incur some damage on the spiral shaft or difficulties evolved in minor adjustment.
- (2) Take out the pattern card, and set the needle selector panel; the fixing should be done invariably by means of the fixing screws provided on the needle selector panel.
On a status, where the panel is just put on the place without fixing by screw, it is not feasible to conduct minor adjustment on the set line, because the panel is unstable in the unfixed stance.
- (3) Insert the card into the card inlet, making the power switch ON, and check the relation between the set line and the card inlet being correct.
 - The gap between the set line bottom edge and the card inlet should be 0.2 or less.
 - The gap between the set line top edge and the card inlet should be 0.1 or more for qualification; the thickness of the set line is 0.3 ~ 0.4; if the set line position is unsuitable, find out the direction and extent of shifting the card required (i.e., upward or downward movement of the card), in comparison with the set line thickness.
- (4) Keeping the power switch on, remove the needle selector panel, where the card feeding gear Z60 being turned to this side, remove the card set line to the bottom edge of the card guide A window to investigate the mutual relation between the set line and the window bottom edge, and to discern how to adjust the position properly.

- (5) Loosen the fixing screw on gear Z60, shift the card by turning the card feeding dial to set it properly in the relation, the set line vs. the reading window; after the rectification fix the fixing screw on gear Z60. In this rectification the relation, the card inlet vs. set line will be kept in a correct status, in which further inspection should be undertaken so as to set the center of the column just meet with the mark sensor position.
- (6) Switch off the power supply, and take out connector S11 and Fuse F201.
- (7) Conduct the procedures given in article 6.2, items (4), (5), (6) and (7).
- (8) Watch out the mark sensor position not to move, and find out the position where its circuit tester indication getting minimum (0.5 ~ 1.0V) by means of slowly turning the card feeding dial to this side, where the relation, the card guide A window bottom edge vs. the columns on the card should be checked.
- (9) Switch off the power supply and insert connector S11 into the power supply board assembly, then the power switch being turned ON. Where, if no change is observed onto the relative position between the card guide A window bottom edge and the columns on the card, it should be in a correct relation.
- (10) If the card moves upward when the power switch on, the mark sensor should be moved upward to the same amount required to meet the card center.
In the case where the card moves downward, the sensor should be removed downward as the same way.
- (11) Checking the relative position, the top face of the sensor frame vs. the mark sensor case top face, loosen its sensor case fixing screw, and adjust the height of the mark sensor.