

INSTRUCTIONS

MODEL SK-312 CARDMATIC



Studio

AUTOMATIC HOME KNITTER

Congratulations on Your Purchase
of the New

STUDIO AUTOMATIC HOME KNITTER
MODEL SK-312 CARDMATIC

Before you start to knit on your "MODEL SK-312 CARDMATIC" STUDIO AUTOMATIC HOME KNITTER we recommend you carefully read this Instruction Book. By using these easy to follow directions you will be able to take full advantage of the excellent performance of your machine. The beautiful creations on this machine are limited only by the imagination of the operator.

NAMES AND FUNCTIONS OF COMPONENT PARTS

CARRIAGE

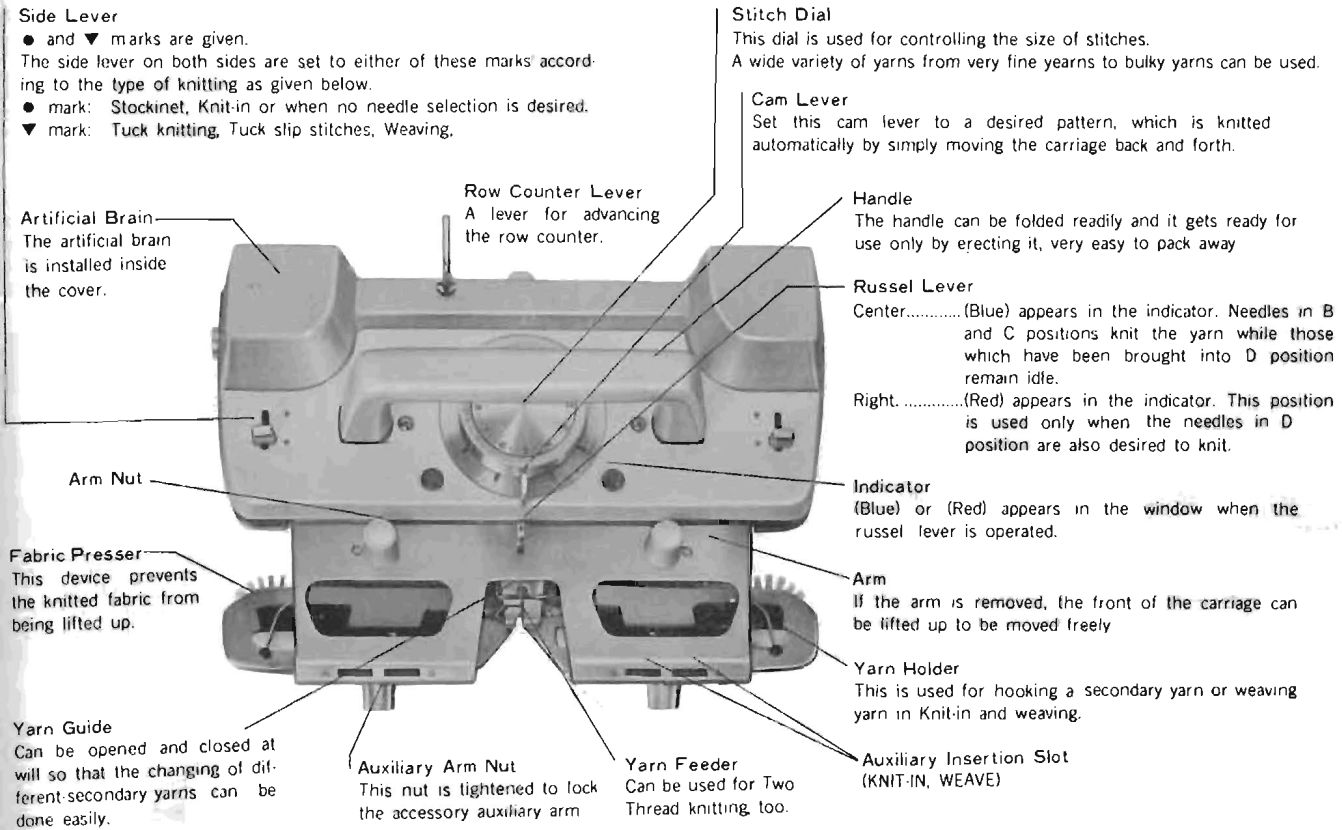

all it

MAIN BODY OF KNITTING MACHINE

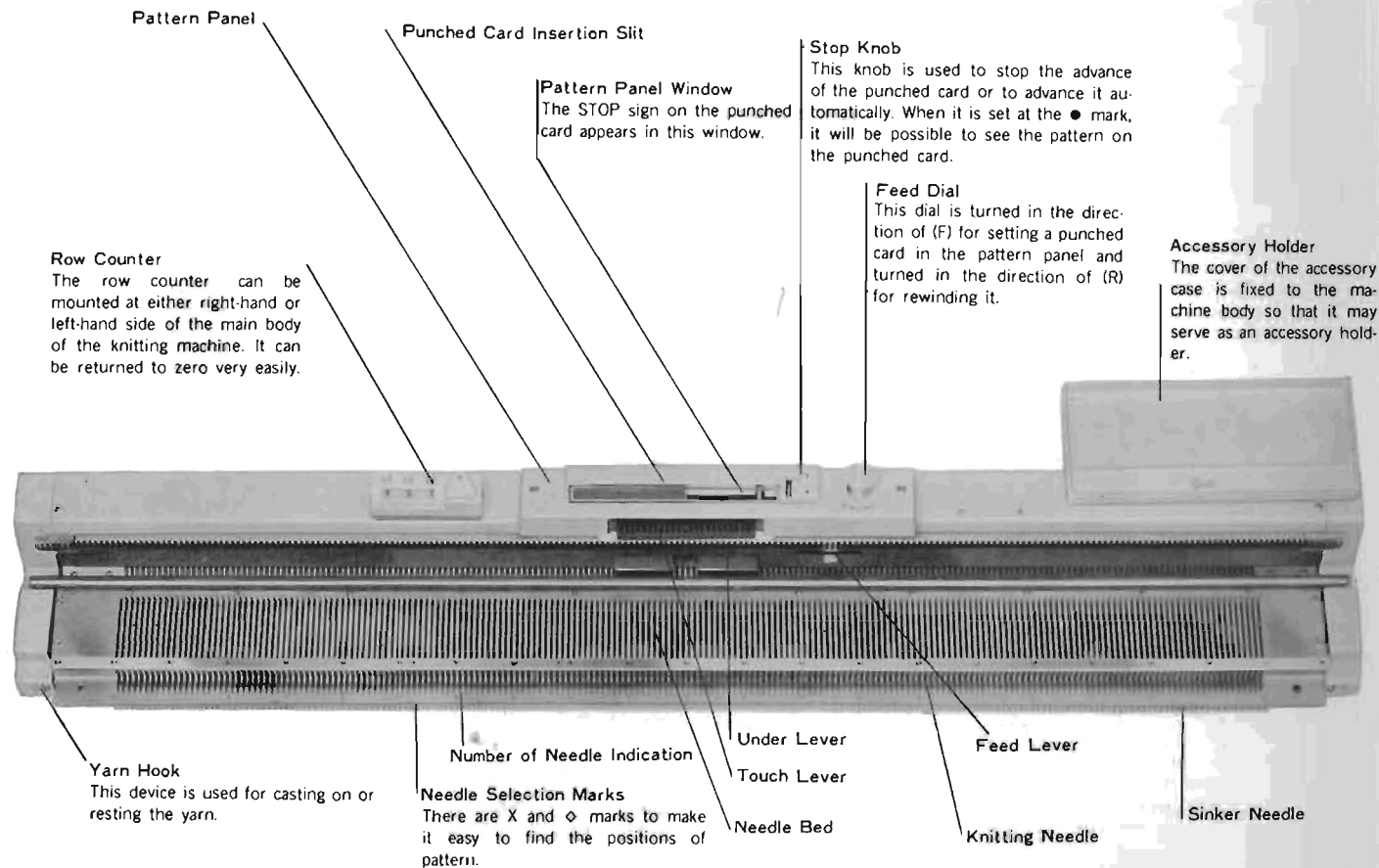

1. ASSEMBLING PROCEDURES

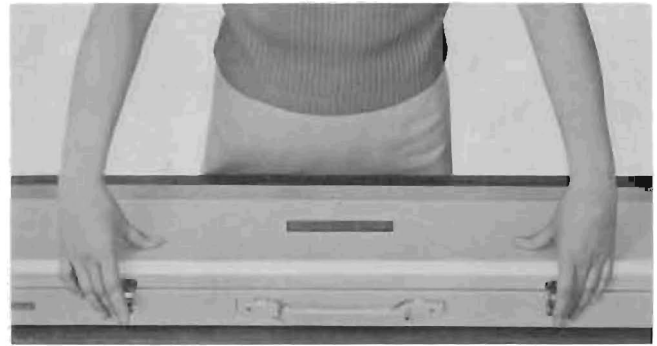
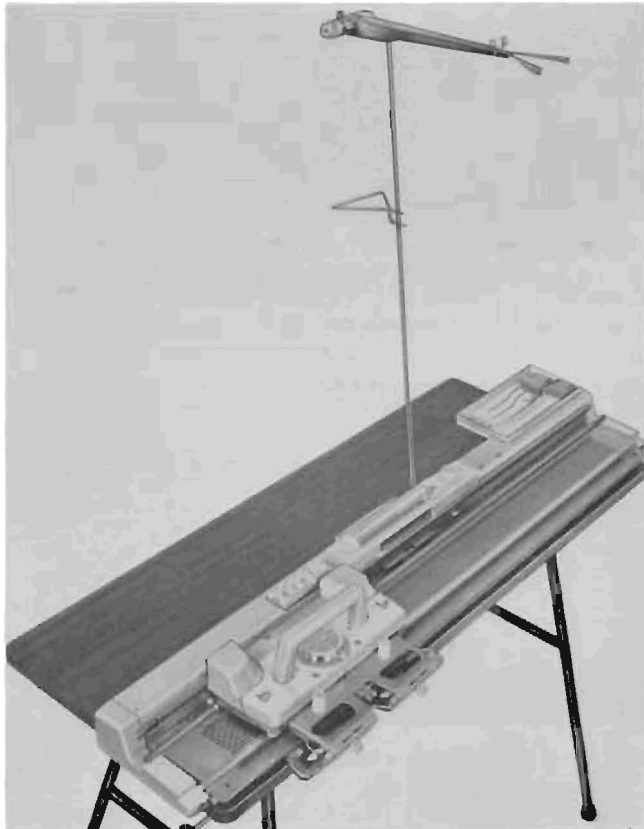

(1) Unfasten the latches.

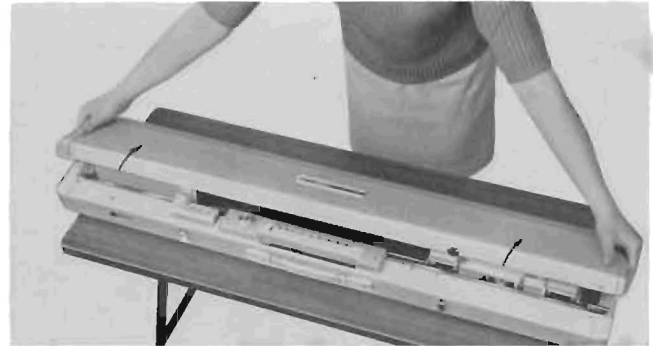

(2) To remove the cover, open it a little and pull it towards you.

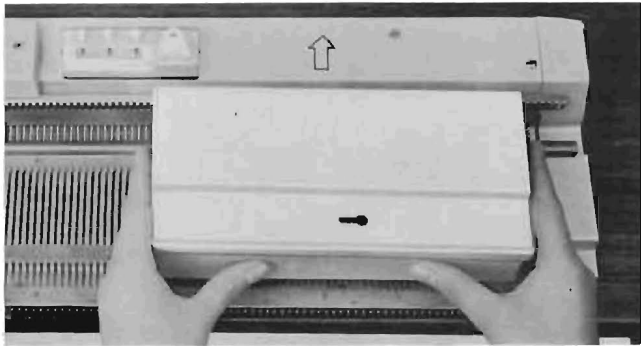

(3) Remove the accessory box.

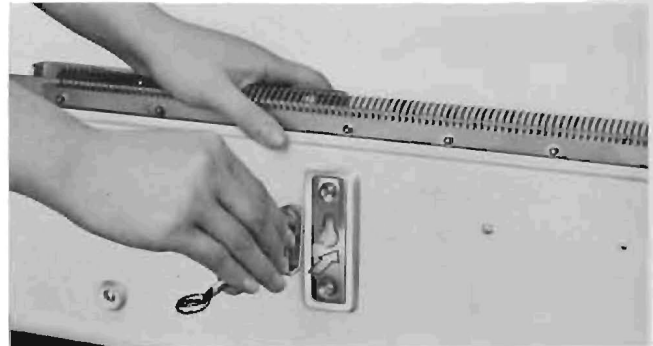
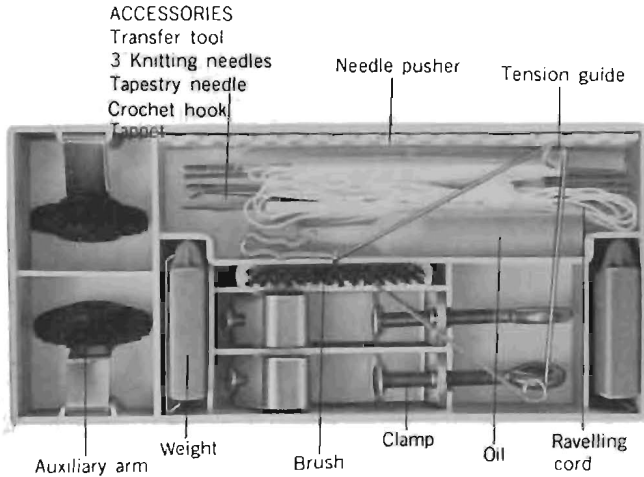

(4) Remove the clamps from the accessory box and insert the head of clamp screw in the center of the clamp receiving hole on the bottom of the machine.

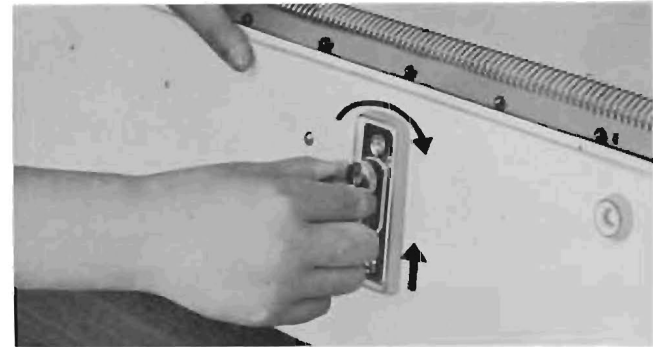

(5) Slide the clamp upward and tighten it firmly by turning it to the right.

Copyright © 1980 by Singer Sewing Company, Inc. All rights reserved. Printed in the U.S.A.

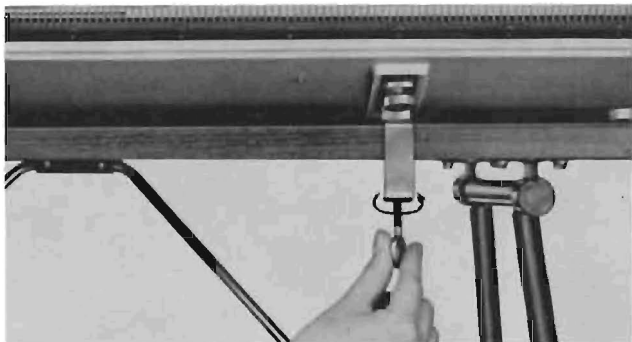

- (6) After both clamps have been fixed firmly in position, fasten the clamp screws to clamp the machine securely to a table on which it is set. Rubber feet are provided on the underside of the machine case so that it may be held steady on the table without using the clamps. However, it is advisable to use the clamps when knitting heavy yarn.

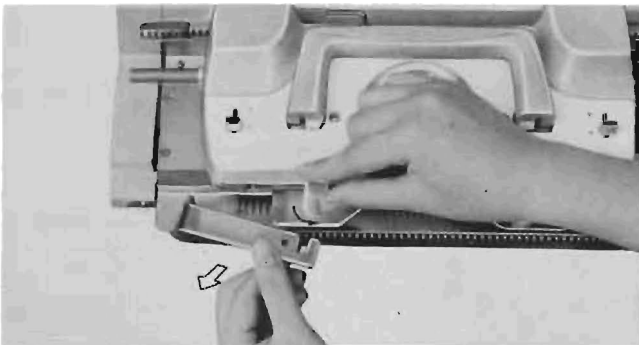

- (7) Loosen the left arm nut and remove the carriage fastener.

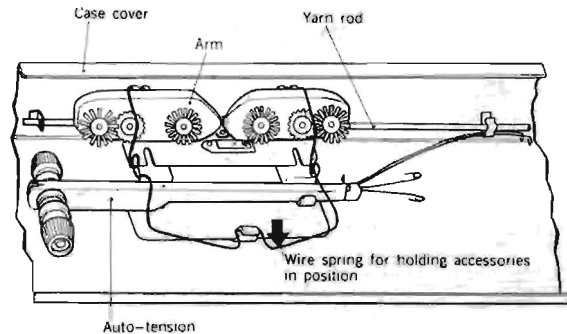

- (8) Release the wire spring which holds the accessories in position inside the case cover and remove the carriage arm.

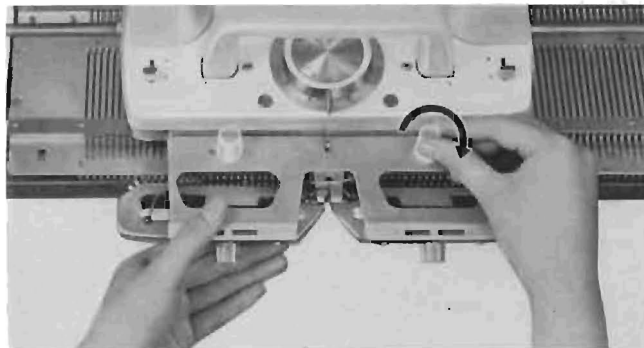

- (9) Loosen the nuts on the carriage arm and push in the arm as far as it goes and tighten the nuts firmly.

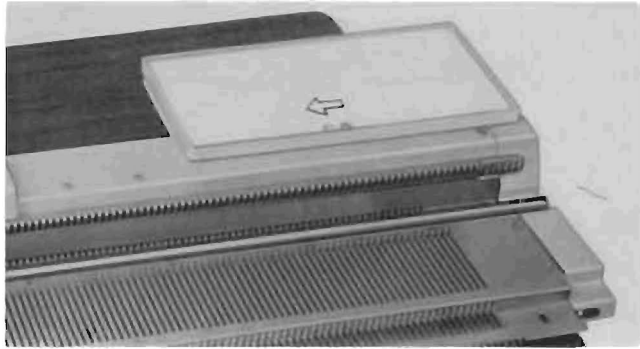

- (10) Install the cover of accessory case onto the pin at the right end of the machine so that it may serve as an accessory holder.

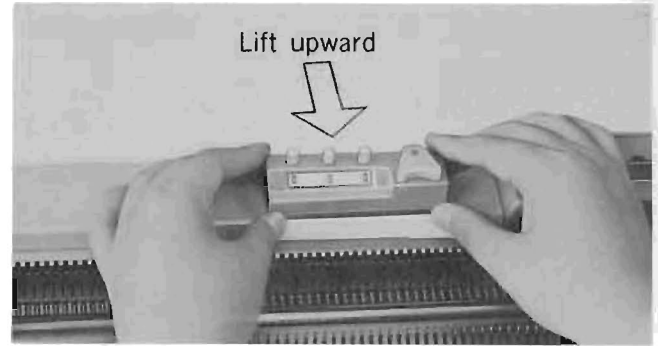

- (11) The row counter can be installed on either right or left side of the pattern panel for your convenience.

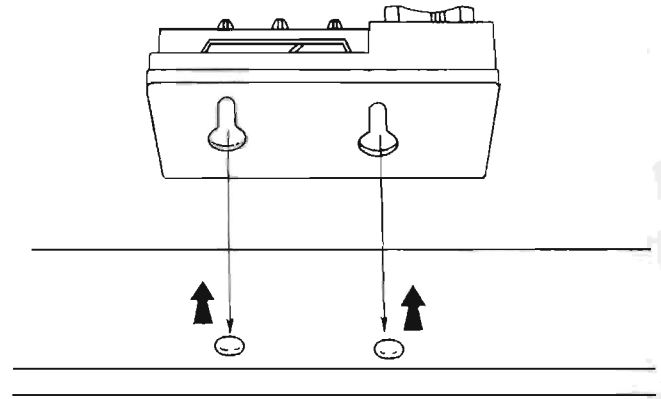

(12) Install the auto-tension in the order indicated in the diagram.

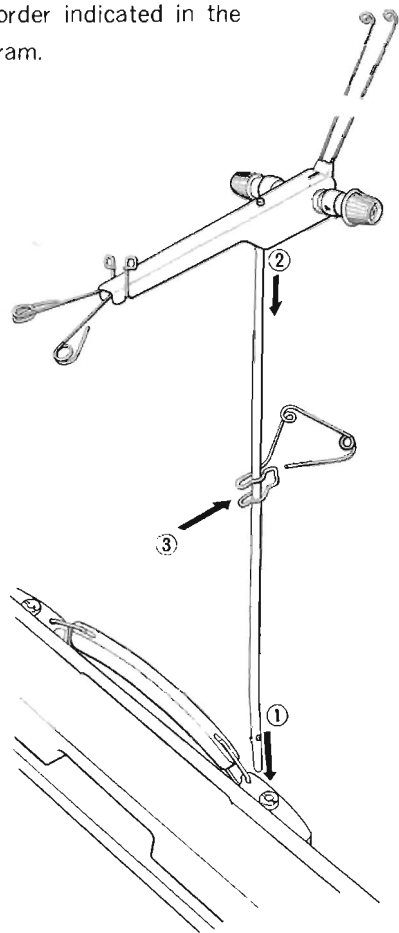

The yarn tension spring must be turned until it comes to a stop making a clicking sound.

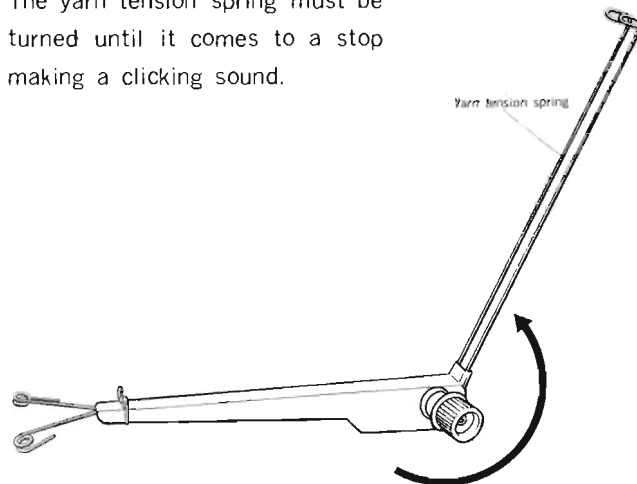

The auto-tension rod can be installed on either side of the handle on the case.

By using an additional set of auto-tension (sold individually), you can knit four different yarns at the same time.

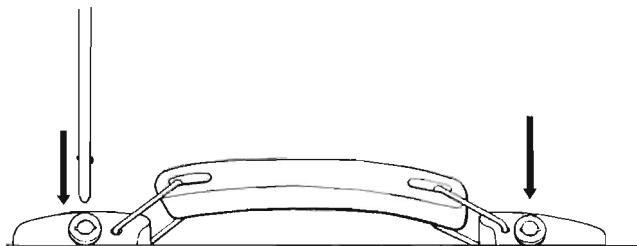

2. PREPARATION FOR KNITTING

(1) Prepare a yarn for knitting.

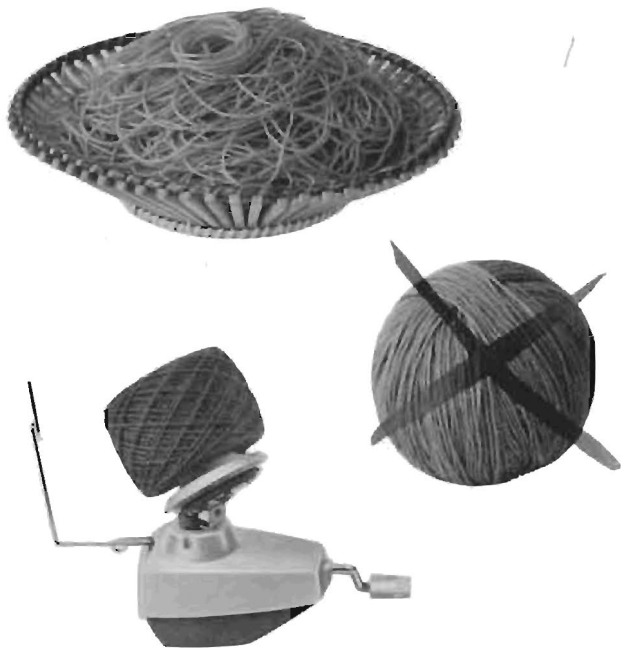

Note: The yarn must be placed well behind the machine so that it may not touch the carriage. If the yarn hangs loosely over the machine, it might get entangled in the "artificial brain". Care is needed to prevent this.

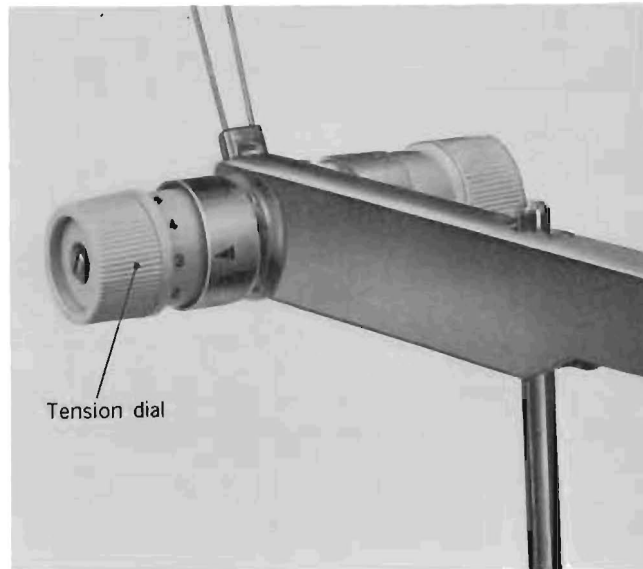

(2) Turn the tension dial to set the numerals to the ▼ mark according to the size of a yarn to be knitted.

Yarn	Numeral
Thin yarns	5~4
Medium yarns	3
Thick yarns	2~1

(3) Thread the yarn through the auto-tension as shown in the figure.

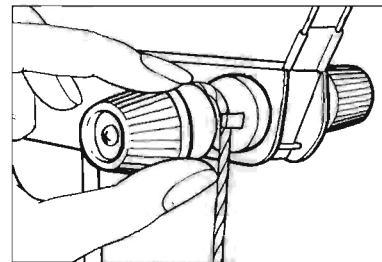
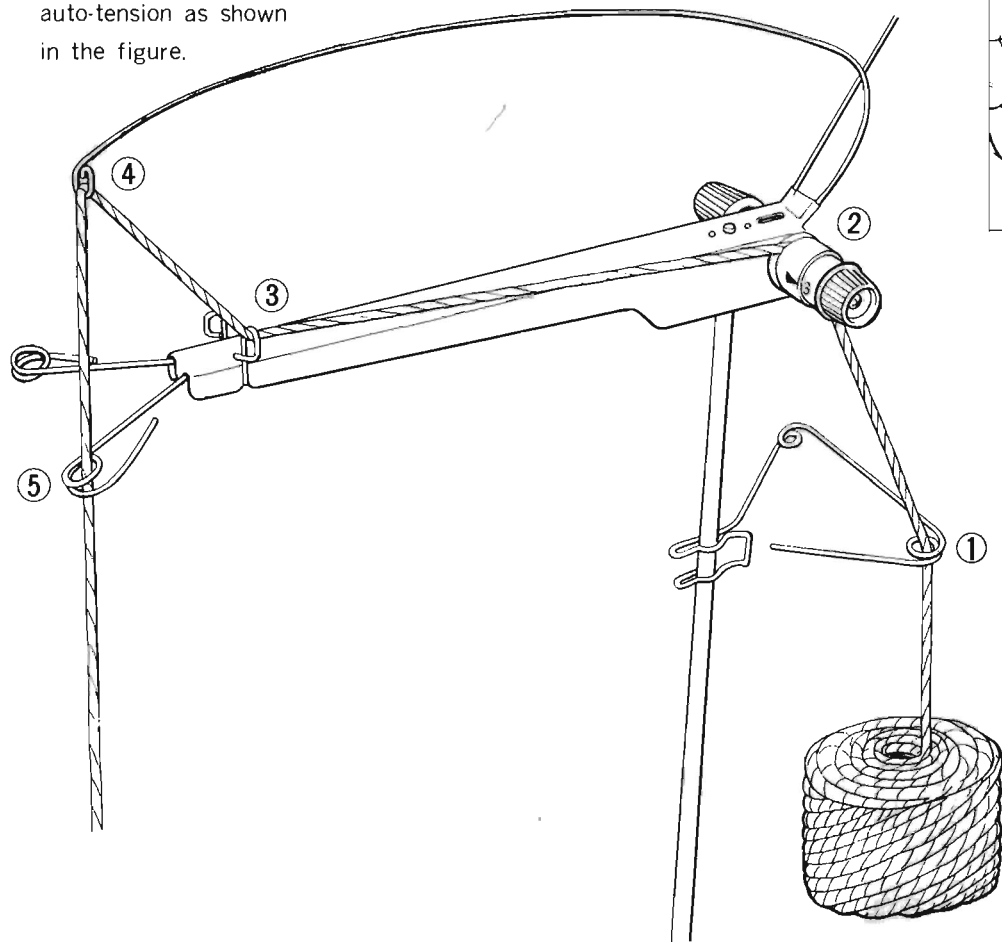

* Make sure the yarn passes inside the pin.

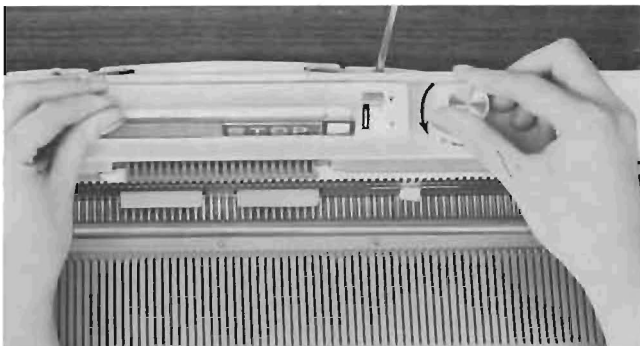

(4) Set the stockinet card in place.

- * Set the stop knob to the ▼ mark and insert the stockinet card into the pattern panel.
- * Turn the feed dial until STOP appears in the window on the pattern panel.

Note: * This card is used to facilitate the smooth movement of the carriage in knitting stockinet. It is not needed in pattern knitting or in knitting several rows of stockinet.

Copyright © 2000 by Leisure Arts, Inc. All rights reserved. No part of this publication may be reproduced without the written permission of Leisure Arts, Inc.

Move the stop knob full to the ● mark. (Do not stop it halfway)

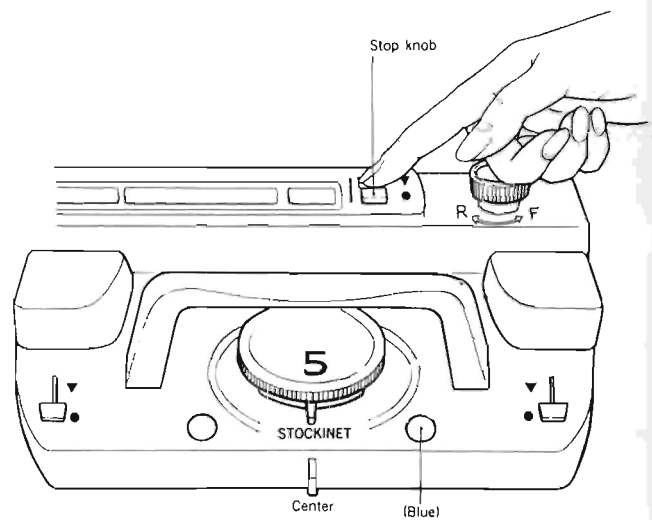

(5) Set the stop knob and the carriage as follows.

- Stop knob ● mark
- Cam lever Stockinet
- Stitch dial 5
- Side lever ● mark
- Russel lever Center (Blue)

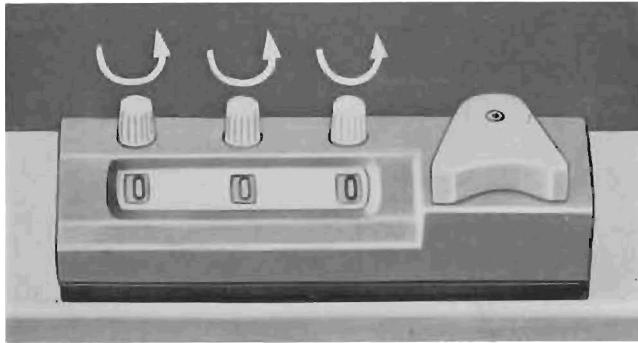

Adjusting the Row Counter

The row counter can be adjusted by turning the knobs on top in either direction.

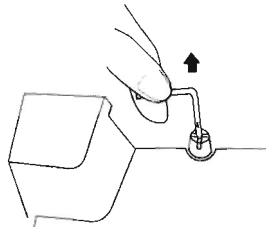

(6) Lift the row counter lever upward.

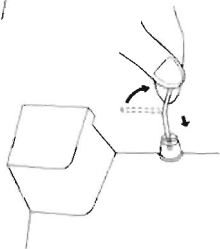

(7) Turn the lever.
(Keep the lever turned inside when the row counter is not used.)

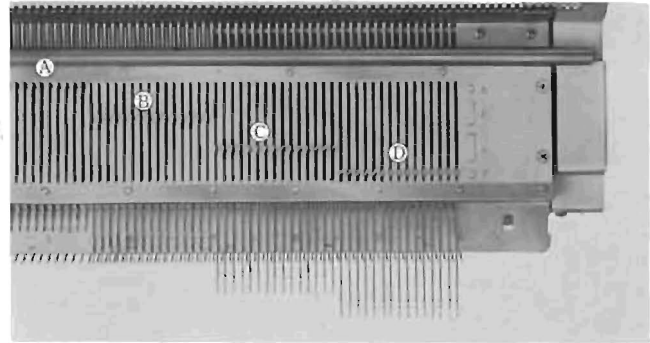

(8) Each end of the needle bed is marked with A, B, C and D, each accompanied with a mark (□), which indicate the positions of the latch needle.

A Position Inoperative

B Position Normal stockinet knitting

C Position Knit-in patterns and Partial knitting
(increasing stitches)

D Position Partial Knitting or selection of
needles by hand.

Latch needle

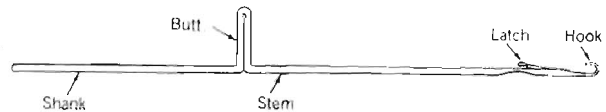

3 CASTING ON AND STOCKINET KNITTING

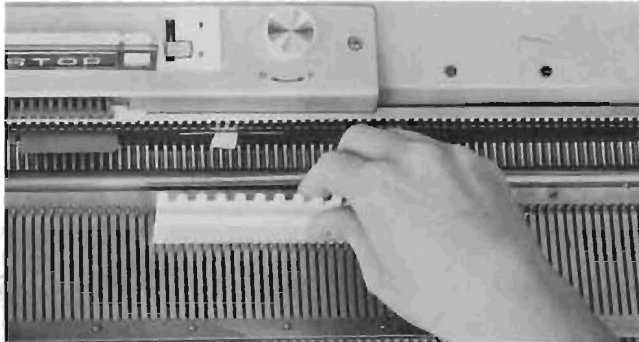

- (1) Select a required number of latch needles to B position, using the flat edge of the needle pusher.

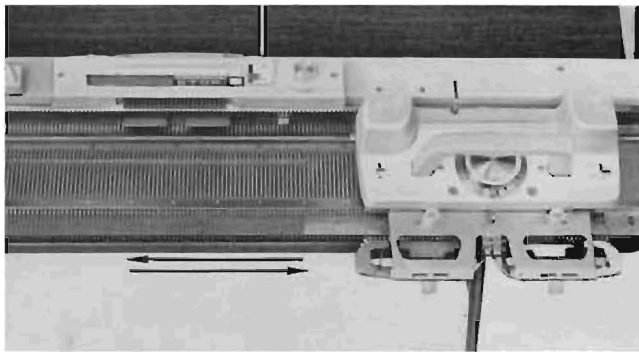

- (2) Move the carriage slowly from side to side to line up the needles in B position, and after that move the carriage to the right side.

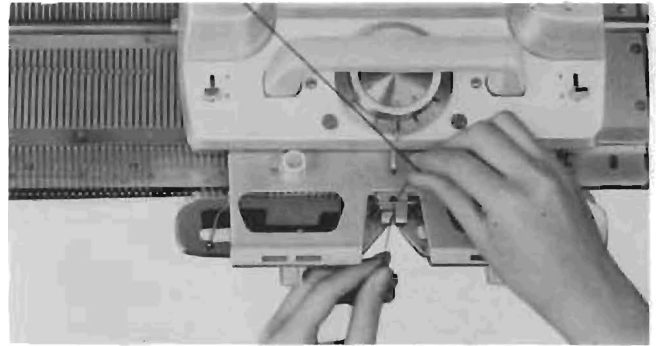

- (3) Pass the yarn through the yarn feeder hole.
(Let it come down 3 or 4 inches below the hole and hold it with one hand or anchor it with a clothes pin.)

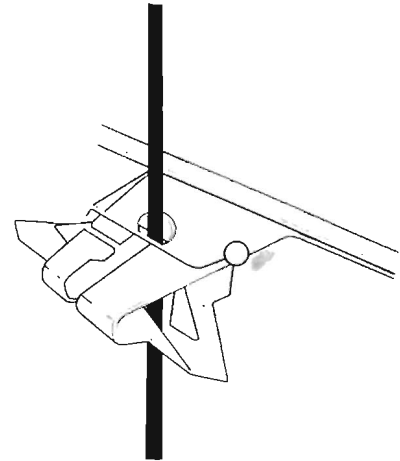

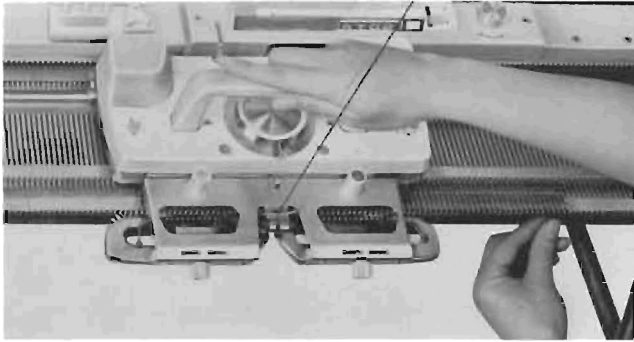

- (4) Move the carriage slowly to the left and the yarn will be hooked by latch needles and sinker needles alternately.

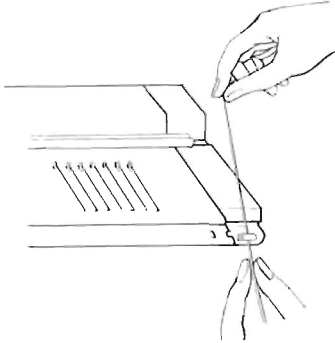

- (5) Insert the ravelling cord in the right yarn hook which is located at the end of the machine. (There is a yarn hook at both ends of the machine.)

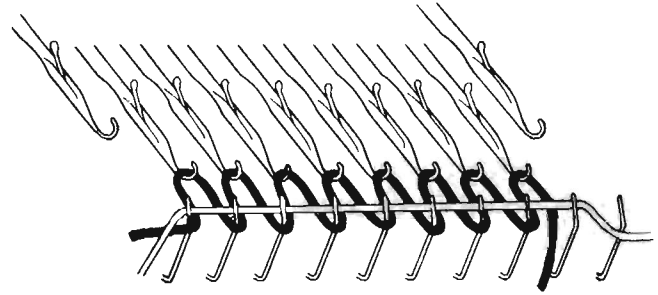

- (6) Pass the ravelling cord over the knitting yarn which is hooked by latch needles and sinker needles.
- (7) With your left hand pull the ravelling cord tight so that yarn will lay straight and come between the sinker needles and the needle bed.

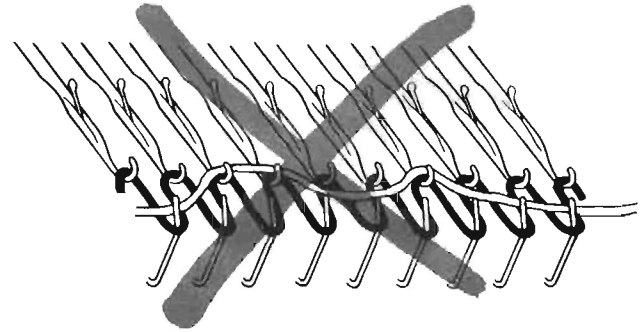

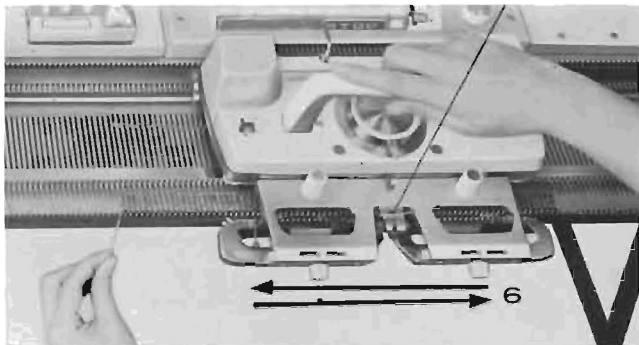

- (8) Keep the ravelling cord tight with the left hand and slowly move the carriage backward and forward to knit six rows. (The carriage must be on the left side of the needle bed at the end of this procedure if a pattern is to be knitted.)

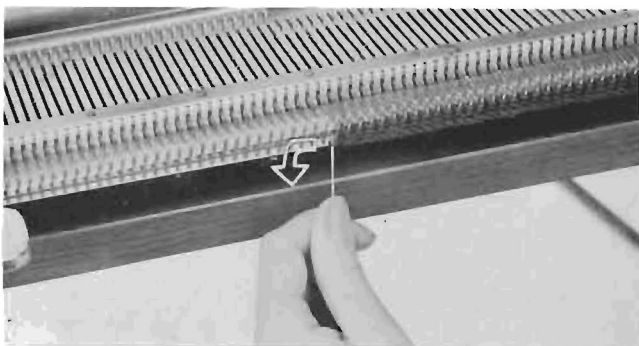

- (9) Remove the ravelling cord from the yarn hook and pull it out from direction hooked. Now the casting on procedure has been completed.

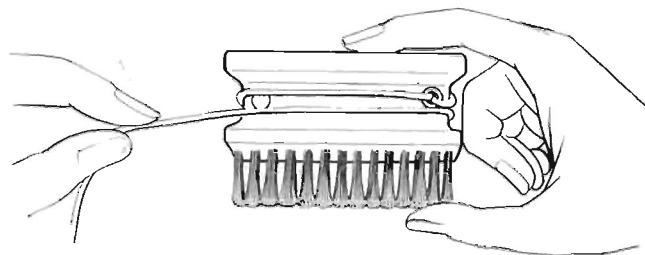

- * Care must be taken not to make a knot in the raveling cord.
- * Tie an end of the raveling cord to the accessory brush (passing it through a hole in the handle of the brush) and wind it round the brush when it is not in use.

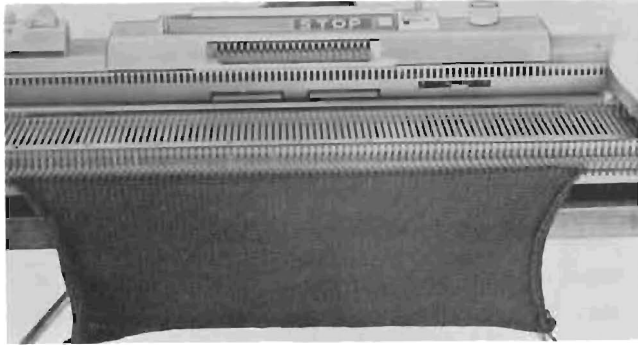

(10) Set the row counter to zero (0) and turn the row counter lever to the operating position. (Refer to Adjusting the Row Counter on Page 9.)

(11) Move the carriage back and forth for stockinet knitting. THE CARRIAGE SHOULD BE MOVED AT AN EVEN RATE.

(Note) When the carriage has jammed and its movement is prevented, do not try to move it by force. In this case, follow the instructions given on page 34 and repair the knitting.

Note: The carriage must be returned after passing the end needle by 1 to 2 inches. Avoid returning the carriage in the middle of the bed.

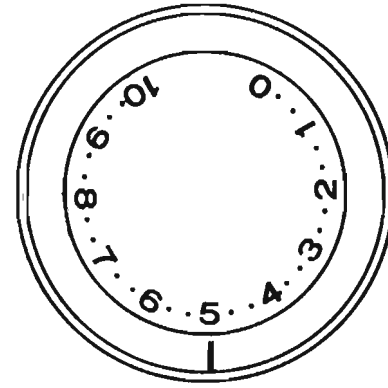

(12) The stitch dial is used to determine the size of stitches according to the thickness of the yarn used. The numerals on the dial are so arranged that the higher the numeral, the larger the stitch, and the lower the numeral the smaller the stitch.

Size of yarn	Range of gauge	Standard gauge
Thin	0 ~ 3	2
Medium	3 ~ 6	5
Thick	6 ~ 9	8
Very thick	9 ~ 10	10

4. PATTERNED KNITTINGS

How to Read the Punched Card

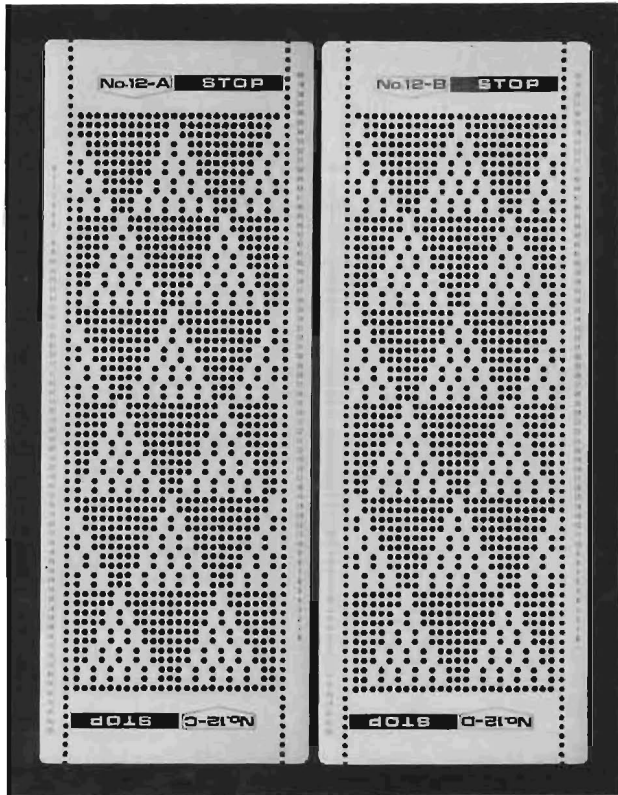

- * The twenty punched cards (each representing a different pattern) that come with the knitting machine have serial numbers from No.1 through No.20 and alphabetical markings A, B, C and D respectively, for example, No.12 A.

These markings help you in selecting the right punched card for a pattern you have picked up from the pattern book.

- * When using a punched card, set the card in the pattern panel with the identification markings facing upward.

How to Use the Card Markings A, B, C and D

- * A direction is basic pattern. By changing the direction, the pattern also changes its direction as shown in the figures below.

A Direction



C Direction

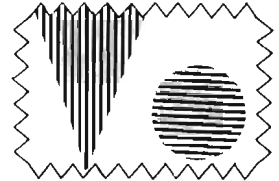

B Direction

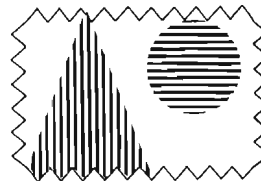

D Direction

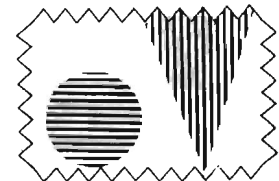

STOP

The STOP sign appearing in the window on the pattern panel indicates the end of the card. Stop the knitting operation and rewind the card back to the ■ mark.

When the knitting operation is finished by using the card only once, knit a row in the ■ mark position to complete the pattern. If the knitting is to be continued further, start again from the ■ mark.



PATTERN ROWS INDICATED ON THE CARD

On the right-hand side of each punched card there are numbers indicating the number of rows of the pattern, and they appear in the pattern panel window at each row.

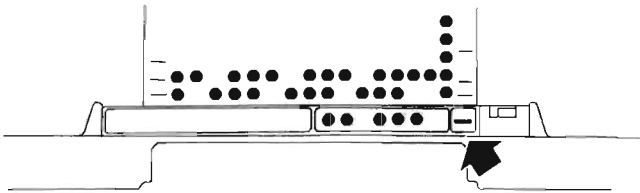

■ MARK

The ■ mark that precedes the 0 mark indicates the position where the punched card is to be set.

When the card is used repeatedly, it must be set back to this position before continuing the knitting operation.

PATTERN BOOK

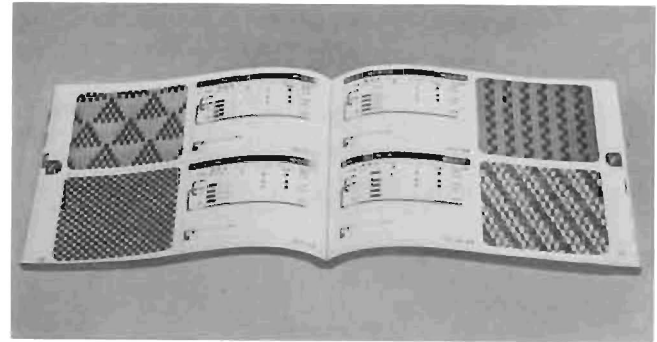

For knitting a pattern, choose the desired pattern from the pattern book and operate the machine according to the instructions given in the operating table.

HOW TO READ THE OPERATION TABLE

The number of rows which appear in the pattern panel window. Operate the machine in the order indicated by these numbers.

Whether you use only one color or two or more colors in your knitting work, use each yarn according to the given instructions.

Set the cam lever to a position indicated in this line.

Set the Russel lever of the carriage to a position indicated in this line.

Set the side lever to a position indicated in this column

This is a preparatory stage before starting the pattern knitting. A row that is knit in this position is not counted in the number of rows. After completing the preparatory knitting of a row, proceed to the 0 mark, following the thick arrow mark

Return to this column when the punched card is used again. The last row in the card is knitted in this position.

The card advances to this column after completion of the preparatory knitting at the bar mark on the top. Here begins the pattern knitting operation.

This sign indicates the ending of the punched card. The card must be rewound back to the bar mark indicated by the arrow mark.

This symbol is used to signify the omission of repeated operations

Set the stop lever to prescribed position.

This column shows the direction in which the carriage is to be moved and the number of rows to be knitted.

Select the needles to knit and the needles to rest beginning at the zero (0) mark in the center of the needle bed. The circle dot (o) indicates the needles to be pushed back to the A position and the bar mark (|) the needles to be used

CARD		No.	○ — A	○ ○	KNITTING < 1 >
PAT. RS.	YARN	CAM LEV.	RUSSEL LEV.	SIDE LEV. (BOTH)	D. (RS.)
—	■	⊙ STOCKINET	(Blue)	▼	↔
—	■	SLIP	(Blue)	▼	→
0	■	SLIP	(Blue)	▼	←
1	■	"	"	"	→
2	■	"	"	"	←
3	■	"	"	"	→
4	■	"	"	"	←
42	■	"	"	"	↔ (39)
STOP					
SET STOP KNOB TO ▼ MARK. < NEEDLE SELECTING >					

ONE PATTERN - 24 STITCHES AND 44 ROWS.



Preparation for Knitting a Pattern

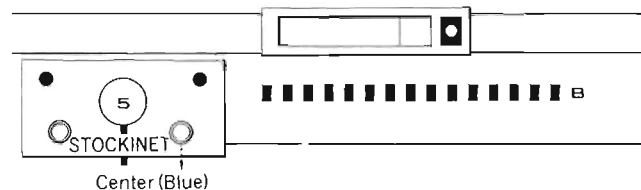
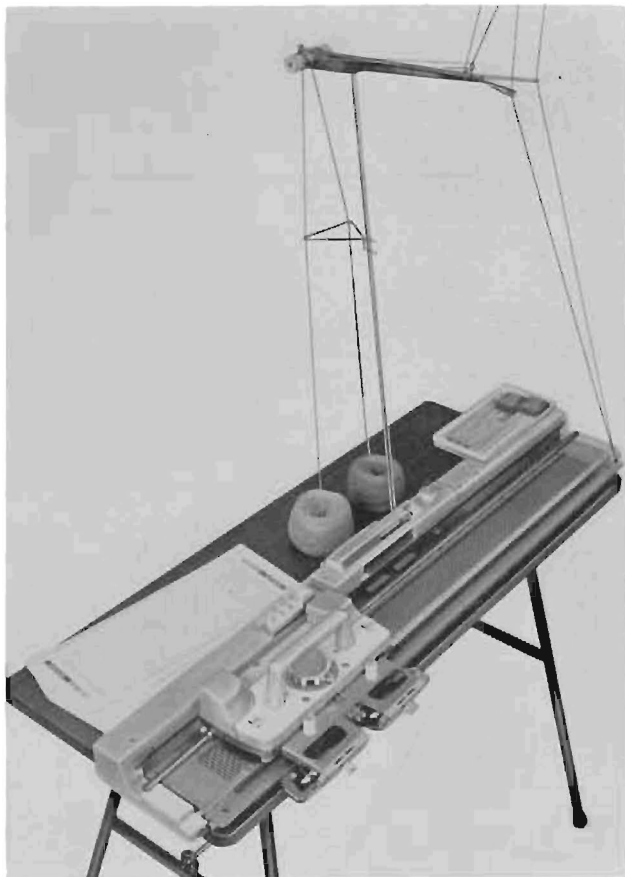

- (1) Before practicing the pattern knitting, knit 7 rows or so of stockinet and then move the carriage to the left side of the needle bed.

CAUTION

- * Be careful not to pull the carriage out of the rail on the needle bed. (If you have accidentally pulled the carriage out of the rail, refer to the information given on page 39)
- * When you operate the carriage, move it in either direction until it passes the pattern panel.
- * Move the carriage at an even rate.

CARD No. 12--A TUCK KNITTING < I >					
PAT. RS.	YARN	CAM LEV.	RUSSEL LEV.	SIDE LEV. (BOTH)	D. (RS.)
—	■	⊙ STOCKINET	(Blue)	▼	↔
0	■	TUCK	(Blue)	▼	↔
1	■	TUCK	(Blue)	▼	↔
58	■	"	"	"	↔ (59)
STOP					
 SET STOP KNOB TO ▼ MARK.					

ONE PATTERN—12 STITCHES AND 20 ROWS

Page 4 in the pattern book

To learn how to do the pattern knitting, carefully study the operation table. In this case, it is advisable to use a medium yarn.

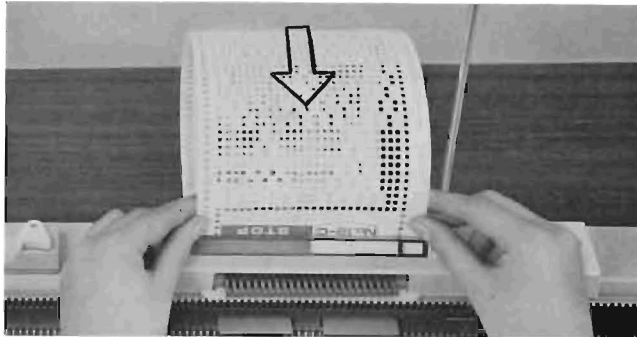

(1) Select No.12-A punched card and insert it through the slit in the pattern panel.

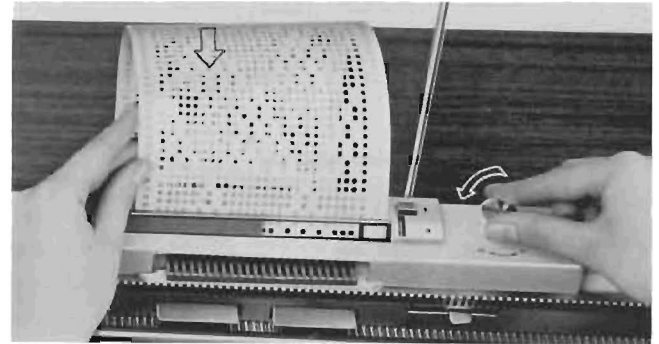

(2) Turn the feed dial in the direction of F until the ■ mark appears in the pattern panel window.

Note: *

- * When inserting the punched card, be sure that it is not crooked or folded.
- * When the stop knob is set to the solid dot ● mark, the punched card will not move. Do not use force to try to move by pulling. When you want to turn the feed dial, set the stop lever to the ▼ mark.

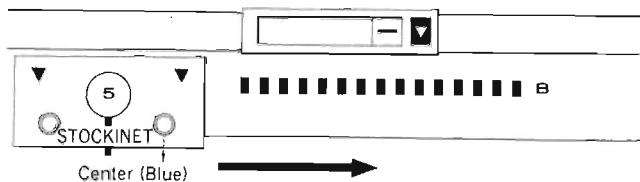

(3) Set each of the regulating parts of the carriage, following the upper **-** mark (as indicated by the arrow) in the operation table. Knit a row by moving the carriage in the direction indicated by the arrow.

(Note) This is a preparatory row before the beginning of pattern knitting and is not counted in the number of rows for the pattern knitting. When the pattern is knitted repeatedly, do not return to this column but to the **-** mark indicated by the red arrow.

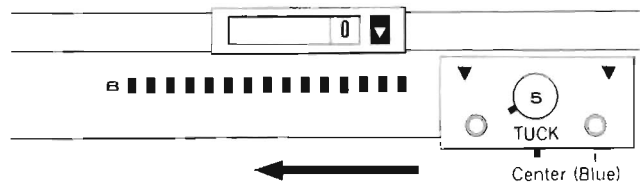

(4) One row has been knitted and the card is set at 0. Reset all regulating parts according to the instructions in the 0 column in the operation table. Set the row counter to 0. Pattern knitting begins.

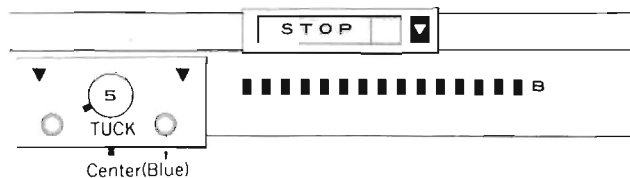

(5) Knit 59 rows by moving the carriage to and fro as indicated by the arrows until the STOP sign appears in the pattern panel window.

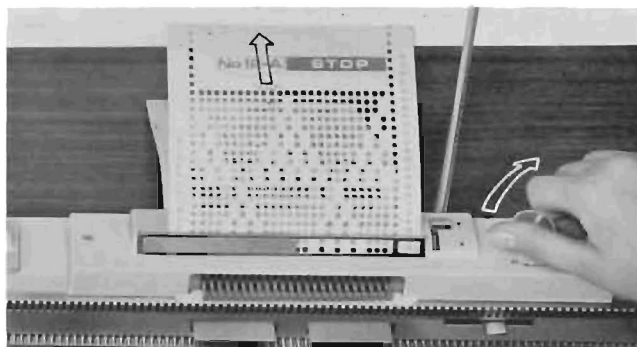

(6) Turn the feed dial in the direction of R to return the card to the **-** mark. (The operation table shifts from STOP to the **-** mark indicated by the red arrow)

(7) Knit one row, following instructions in the **-** mark column.

(8) Repeat the process of advancing from 0 to STOP and back to the **-** mark indicated by the red arrow for continuous design.

TUCK SLIP STITCHES

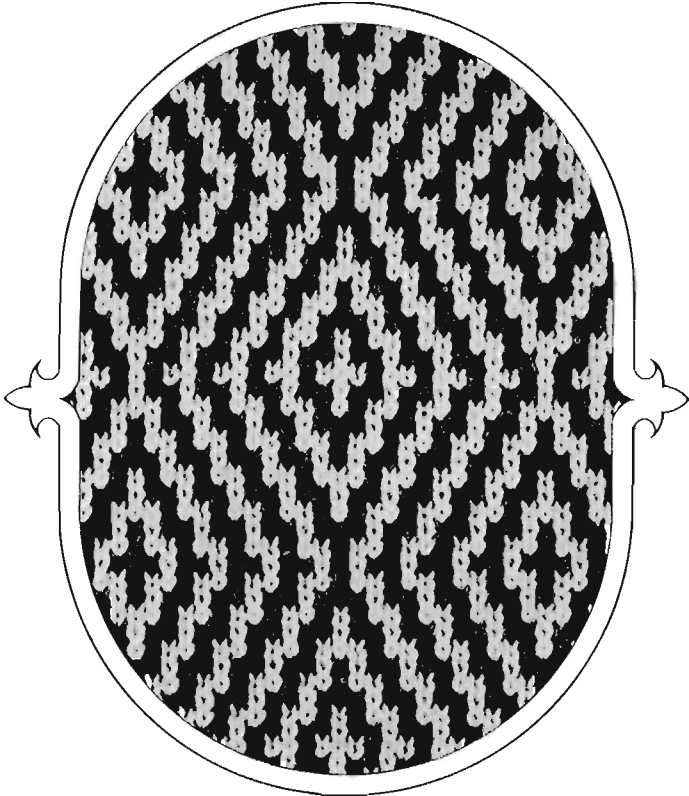

* Pattern Knitting Using Two Different Colored Yarns

* Pattern Knitting Using Two Different Colored Yarns

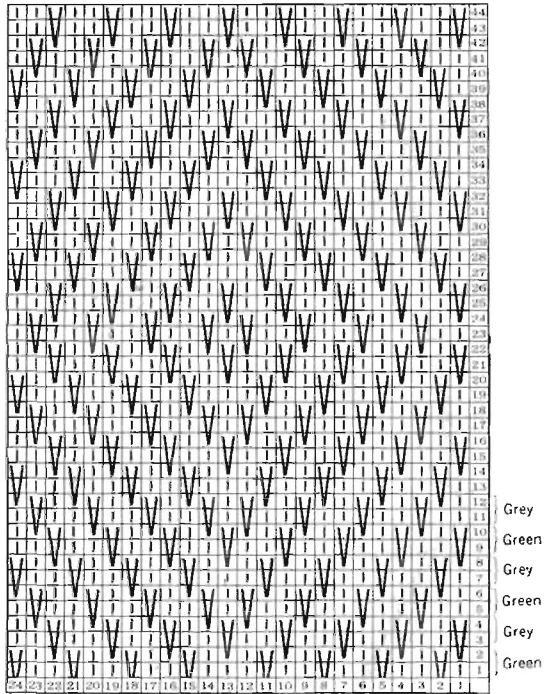

- Slip stitch
A loop in the lowest row is Pulled up with
yarn lying behind it.
- Knit stitch
Face loop of stocknet.

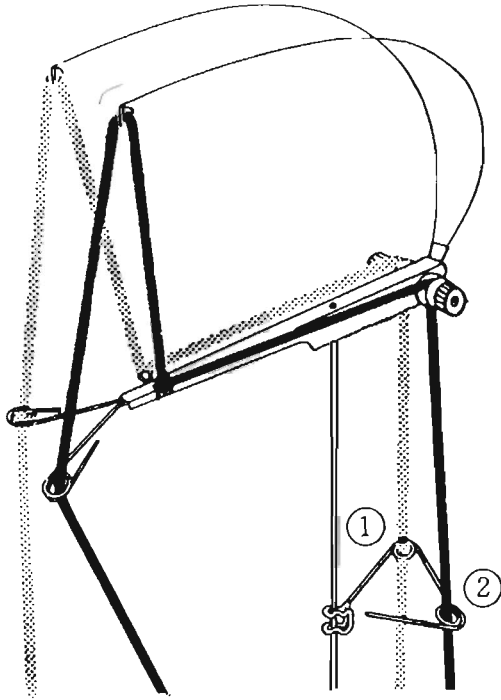

- * Thread the yarns through the auto-tension and hold them by inserting the ends in the yarn hook.
- * The yarns must be passed through the loops of the tension guide as shown in the above figure.

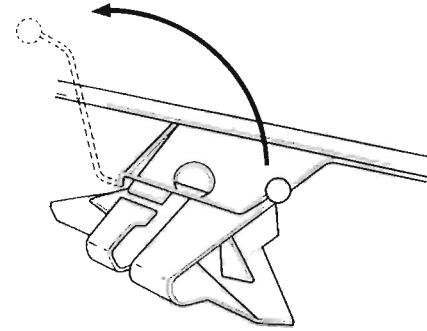

- * When two yarns are used, the knitting operation will be easier if the yarn guide is kept open.

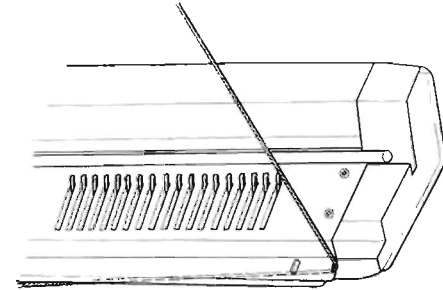

- * Rest the yarn not used in the yarn hook until the * mark appears to signal you to change the yarn. Be careful that the two yarns are not entangled each other.

CARD No. 18-A TUCK SLIP STITCHES<1>					
PAT. RS.	YARN	CAM LEV.	RUSSEL LEV.	SIDE LEV. (BOTH)	D. (RS.)
—	■	⊙ STOCKINET	(Blue)	▼	→
0	■	SLIP	(Blue)	▼	→
1	■	SLIP	(Blue)	▼	←
2	■	*	*	*	→
3	■	*	*	*	←
4	*	*	*	*	→
42	*	*	*	*	← (39)
STOP					

 SET STOP KNOB TO ▼ MARK.
 • Charge color every second row.

ONE PATTERN—24 STITCHES AND 4 ROWS

Page 21 in the pattern book.

- (1) Insert Punched Card No.18-A through the Punched Card Insertion Slit.

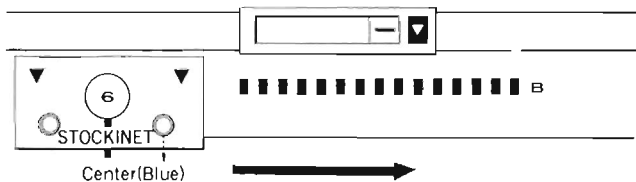

- (2) Set the card at the — mark and knit one row using grey yarn in the direction of the arrow. (This is a preparatory step before starting pattern knitting.)

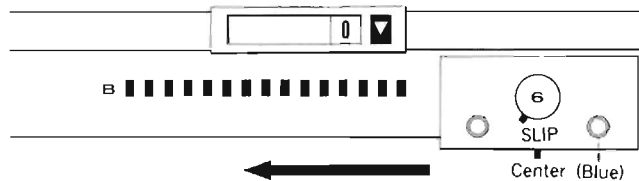

- (3) Set the carriage according to the instructions for the 0 row given in the operation table.
- (4) Switch to green yarn and knit two rows (at 0 and 1).
- (5) Switch back to grey yarn and knit two rows (at 2 and 3).
- (6) From the * mark on, continue knitting the pattern, switching from one yarn to the other, until the STOP sign appears.
- (7) Turn the feed dial to return the card back to the — mark indicated by red arrow.
- (8) Knit one row, following the instructions for the — mark row indicated by the red arrow.
- (9) Repeat the instructions from 0 to STOP and back to the — mark.

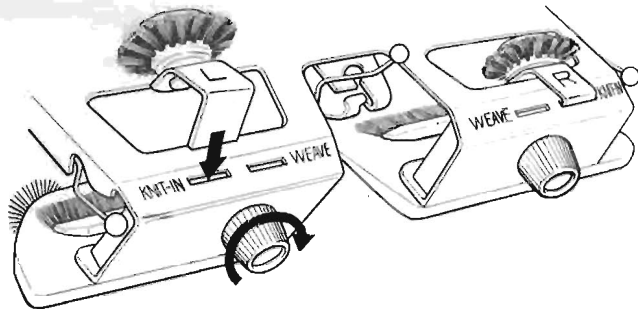

(1) On both sides of carriage arm install the auxiliary arms in the slots (KNIT-IN), push them in as far as possible, and tighten firmly.

(2) Thread the two different colored yarns through the auto-tension.

* Insert the contrasting yarn into the yarn hook and pass the other yarn through the yarn feeder.

CARD No. 15 A		KNIT - IN <2>			
PAT. RS.	YARN 2nd MAIN	CAM LEV. KNIT-IN 1	RUSSEL LEV. (Blue)	SIDE LEV. (BOTH)	D. (RS.)
0	■ □	●	●	●	→
46	■ □	●	●	●	← (47)
STOP					
SET STOP KNOB TO ▼ MARK.					

ONE PATTERN - 24 STITCHES AND 48 ROWS

Page 33 in the pattern book

(3) In the knit-in operation, the knitting needles always come out to the C position. (The stitch never goes beyond the latch.)

Cam lever

Knit-in 1 ... Knitting needles line up in the C position after knitting stockinet irrespective of the pattern instructed by the punched card inserted in pattern panel.

Knit-in 2 ... Cam lever must be set to 2 before starting pattern knitting. Latch needles line up in the C position while knitting the instructed pattern.

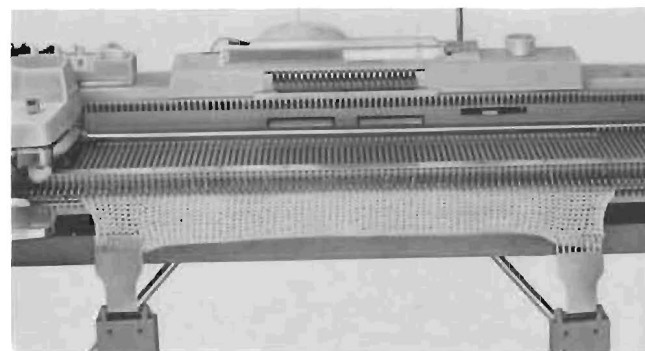

(4) In the beginning, knit several rows of stockinet and stop the carriage on the left side of the needle bed. Attach the accessory weights to both ends of the knitted piece.

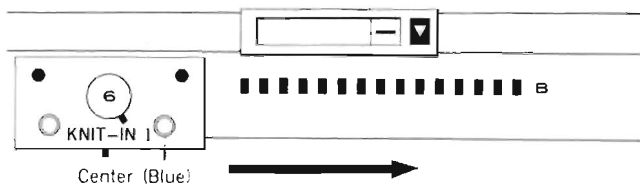

- (1) Insert the punched card No.15-A in the pattern panel. Set the carriage, following instructions for the upper \blacksquare mark.
- (2) Knit one row in the direction of the arrow with the yarn coming through the yarn feeder. One row of stockinet stitches has been knitted and the needles line up in the C position.

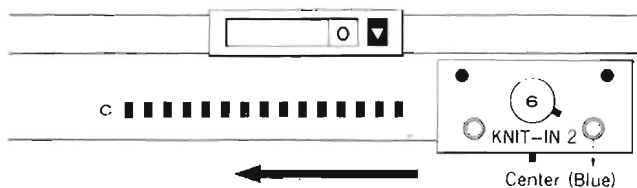

- (3) Set the carriage, following the instructions for the 0 mark.

(4) Now you are ready to start pattern knitting.

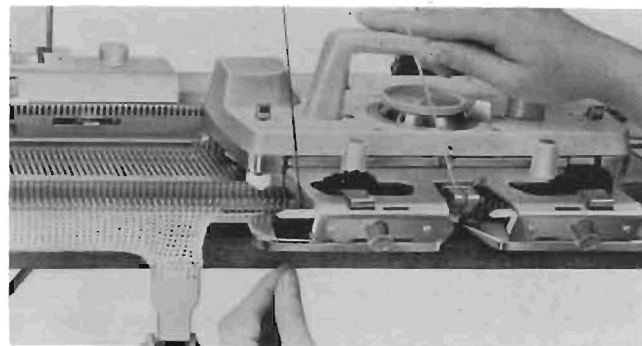

- * Remove the contrasting yarn from the yarn hook on which it has been rested, and hook it on the yarn holder on the arm on the side to which the carriage is to be moved.
- (5) Knit one row, which is the first row of pattern knitted with the two yarns at one time. The latch needles line up in the C position.
 - (6) Change the contrasting yarn to the yarn holder on the other arm in the direction in which the carriage is moved to knit the second row.
 - (7) Continue knitting, changing the contrasting yarn from one arm to the other, until the STOP sign appears.
 - (8) Return the card from STOP to the \blacksquare mark, turning the feed dial.
 - (9) Knit one row, following instructions for the \blacksquare mark indicated by a red arrow.
 - (10) Repeat the instructions from 0 to STOP and back to the \blacksquare mark (pointed by a red arrow).
- * The weights holding the knitted piece downward must be moved upward as the knitting operation progresses.

2 Correcting Pattern Stitches

- (1) Rip out as many rows as needed to repair knitted piece. (In the case of knit-in, undo the fabric after the needles have been lined up in the B position.)
- (2) Turn the punched card and the row counter back by the number of unravelled rows.

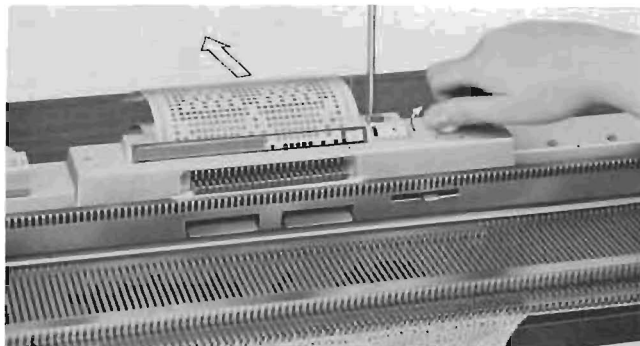

- (3) If the stop knob and the carriage are set as instructed below, the carriage will be moved across the needle bed without knitting and memorize the pattern to be knitted when the carriage is moved next.

When Knitting Yarn Is in the Opposite Side of Carriage

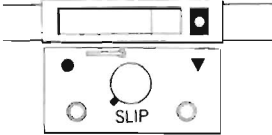
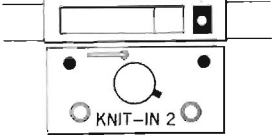
Pattern knitting other than knit-in	Knit-in
<p>(1) Stop knob.....(●) Cam lever.....Slip Side lever.....(●) in the direction of carriage movement Row counter lever.....Turned aside</p>	<p>(1) Stop knob.....(●) Cam lever.....Knit-in 2 Side lever.....(●) on both sides Row counter lever.....Turned aside</p>
	
<p>Set the carr. lever as shown above and return carriage to the side of yarn.</p>	<p>Set cam lever as above and return carriage to the side of yarn (needles will be back in C position).</p>
<p>(2) Reset stop knob to ▼ and carriage controls to their former positions and knit on.</p>	<p>(2) Set stop knob to ▼, turn row counter lever crosswise and knit on.</p>

Knitting Yarn Is on the Same Side of Carriage

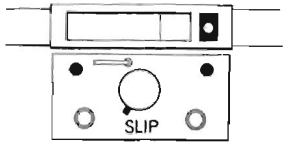
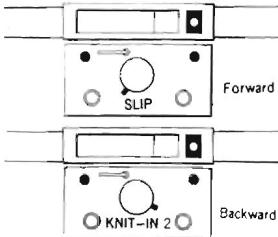
Pattern knitting other than knit-in	Knit-in
<p>(1) Stop knob.....(●) Cam lever.....Slip Side lever.....(●) on both sides Row counter lever..... Turned aside</p>  <p>Set the cam lever as above and move the carriage back and forth.</p> <p>(2) Set stop knob to ▼ and reset carriage controls to their former positions and knit on.</p>	<p>(1) Stop knob.....(●) Cam lever..... Forward (Slip) Backward (Knit-in 2) Side lever.....(●) on both sides Row counter lever..... Turned aside</p>  <p>Set the cam lever as above and move the carriage back and forth.</p> <p>Forward { Carriage moves without knitting. Backward { Carriage moves without knitting and needles come out in C position.</p> <p>(2) Set stop knob to ▼ and turn side lever crosswise and knit on.</p>

Note: * Be sure that the stop knob is reset to ▼ mark before you resume knitting.

* If you operate the machine to knit a pattern with the stop knob remaining at ● mark, the punched card will not be advanced. In this case, follow the same procedure instructed on page 35 (In Knit-in).

(3) Knitting Beyond "STOP" Sign on Punched Card

- Rip the excessive rows one by one while turning back the row counter each time a row is undone. Continue this procedure until the final number mark of the punched card appears in the pattern panel window.

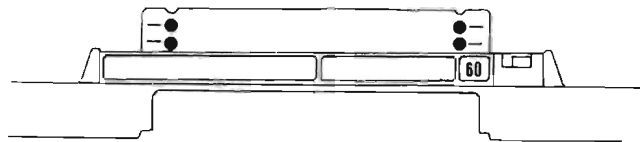

- Number mark on card 0
 Stop knob ● mark
 Cam lever Slip
 Side lever ● mark on both sides
 Row counter lever Turned inside

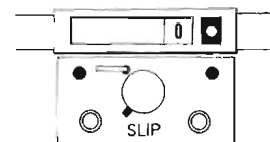

After following the above instructions to have the machine memorize the desired pattern correctly, set the side lever to ▼ mark, reset carriage controls to their former positions and start knitting again.

(Refer to "Correcting Pattern Stitches" on page 37.)

- (2) Attach the accessory weights to both ends of the knitted piece.
- (3) Set the carriage, following the instructions in the operation table.

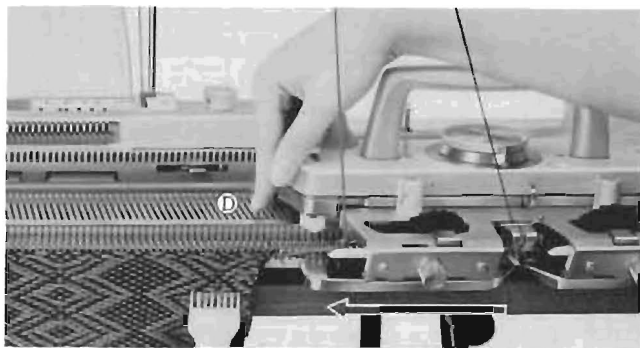

- (4) To prevent the knitted pattern from being shaped wrong bring one end needle to the D position on the carriage side and hook the threading yarn onto the yarn holder on the arm in the direction in which the carriage is to be moved.
- (5) Knit one row, moving the carriage in the direction indicated by an arrow.
- (6) Bring a needle on the side of the carriage to the D position and change the threading yarn to the yarn holder on the arm in the direction in which the carriage is to be moved and continue knitting.

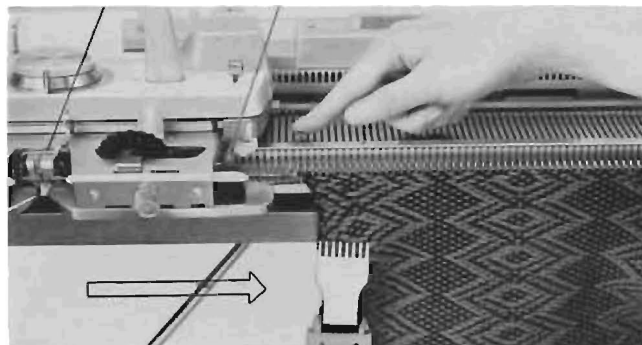

- (7) Move the carriage from left to right.
- (8) Continue knitting, changing the threading yarn from one arm to the other as the carriage changes its direction of movement, and pulling end needles to the D position, until the STOP sign appears in the pattern panel window.
- (9) Return the card from STOP back to the ■ mark.
- (10) Knit one row, following the instructions in the ■ mark line indicated by a red arrow.
- (11) Continue knitting, repeating the process of proceeding from 0 to STOP and back to the ■ mark indicated by a red arrow.

Note : * Set the Russel lever to the right (red) for operating the needles pulled to the D position at the end of the knitted fabric.
 * The tension dial must be adjusted as follows for the threading yarn.

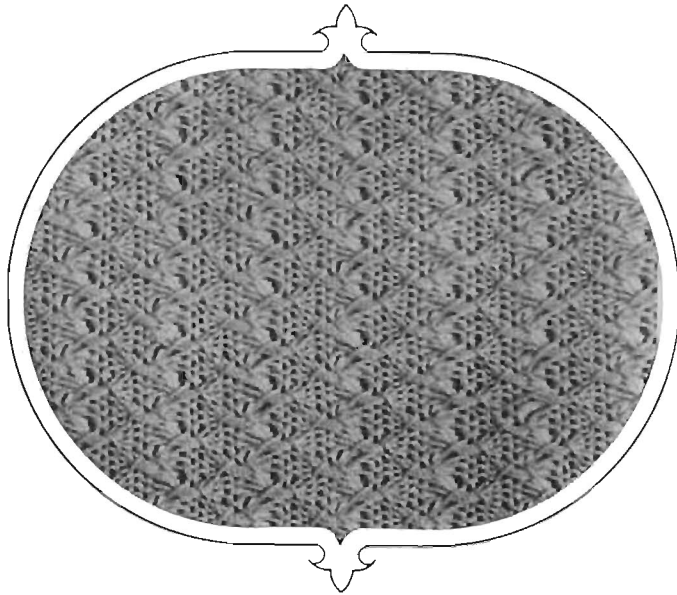

Medium yarn	} 4~5
Thick yarn	

LACE KNITTING



* Lacy patterns are openwork, the designs knitted with thin cotton thread, summer yarns or very thin woolen yarn and the like. By using the techniques of resting needles and tucking stitch, delicate, ornamental fabric can be knitted very easily.

-	-	-	-	-	-	-	-	-	-	-	-	-	-	-	-	-	-	-	-	-	24	
-	-	-	-	-	-	-	-	-	-	-	-	-	-	-	-	-	-	-	-	-	-	23
-	-	-	-	-	-	-	-	-	-	-	-	-	-	-	-	-	-	-	-	-	-	22
-	-	-	-	-	-	-	-	-	-	-	-	-	-	-	-	-	-	-	-	-	-	21
-	-	-	-	-	-	-	-	-	-	-	-	-	-	-	-	-	-	-	-	-	-	20
-	-	-	-	-	-	-	-	-	-	-	-	-	-	-	-	-	-	-	-	-	-	19
-	-	-	-	-	-	-	-	-	-	-	-	-	-	-	-	-	-	-	-	-	-	18
-	-	-	-	-	-	-	-	-	-	-	-	-	-	-	-	-	-	-	-	-	-	17
-	-	-	-	-	-	-	-	-	-	-	-	-	-	-	-	-	-	-	-	-	-	15
-	-	-	-	-	-	-	-	-	-	-	-	-	-	-	-	-	-	-	-	-	-	14
-	-	-	-	-	-	-	-	-	-	-	-	-	-	-	-	-	-	-	-	-	-	13
-	-	-	-	-	-	-	-	-	-	-	-	-	-	-	-	-	-	-	-	-	-	12
-	-	-	-	-	-	-	-	-	-	-	-	-	-	-	-	-	-	-	-	-	-	11
-	-	-	-	-	-	-	-	-	-	-	-	-	-	-	-	-	-	-	-	-	-	10
-	-	-	-	-	-	-	-	-	-	-	-	-	-	-	-	-	-	-	-	-	-	9
-	-	-	-	-	-	-	-	-	-	-	-	-	-	-	-	-	-	-	-	-	-	8
-	-	-	-	-	-	-	-	-	-	-	-	-	-	-	-	-	-	-	-	-	-	7
-	-	-	-	-	-	-	-	-	-	-	-	-	-	-	-	-	-	-	-	-	-	6
-	-	-	-	-	-	-	-	-	-	-	-	-	-	-	-	-	-	-	-	-	-	5
-	-	-	-	-	-	-	-	-	-	-	-	-	-	-	-	-	-	-	-	-	-	4
-	-	-	-	-	-	-	-	-	-	-	-	-	-	-	-	-	-	-	-	-	-	3
-	-	-	-	-	-	-	-	-	-	-	-	-	-	-	-	-	-	-	-	-	-	2
-	-	○	-	○	-	○	-	○	-	○	-	○	-	○	-	○	-	○	-	○	-	1
20	19	18	17	16	15	14	13	12	11	10	9	8	7	6	5	4	3	2	1			

CARD No. 3 - A LACE KNITTING < >					
PAT. RS.	YARN	CAM LEV.	RUSSEL LEV.	SIDE LEV. (BOTH)	D. (RS.)
—	■	⊙	STOCKINET (Blue)	▼	↔
0	■	TUCK	(Blue)	▼	↔
54	■	TUCK	(Blue)	▼	↔ (SS)
STOP					
 SET STOP KNOB TO ▼ MARK. (NEEDLE SELECTING) 					

ONE PATTERN - 4 STITCHES AND 8 ROWS

Page 55 in the pattern book.

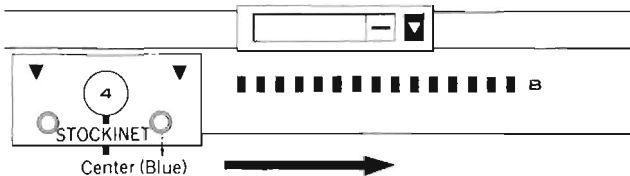

- (1) Insert the punched card No.3-A in the pattern panel and knit one row of stockinet, moving the carriage in the direction indicated by an arrow, following the instructions in the — mark line in the operation table.

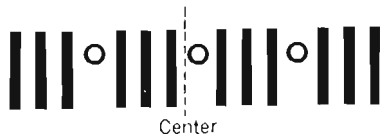

- (2) Beginning at center of machine bring the needles to A and B positions as shown in the needle resting diagram in the operation table and decrease the A

position needles (non-knitting) on to the needles left in B position. Push the needles that are now free back to A position.

Note: If design is knitted for bonding yardage, select the needles according to the operation table before casting on and ■ mark is knit. This eliminates the need for the decreasing procedure.

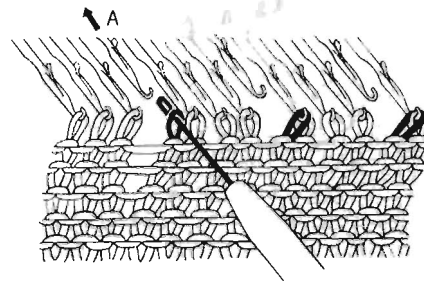

- (3) After completion of the above (2) procedure, set the carriage, following the instructions in the operation table.

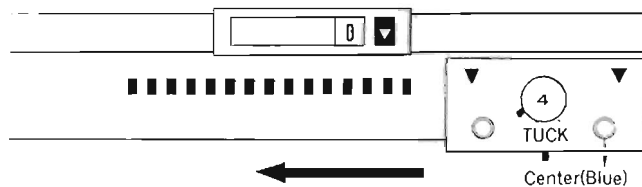

- (4) Continue knitting from 0 to STOP and return the card back to the — mark.
 (5) Knit one row, following the instructions in the line of the ■ mark indicated by a red arrow.
 (6) Continue knitting, repeating the process of proceeding from 0 to STOP and back to the — mark (indicated by a red arrow).

TWO THREAD KNITTING

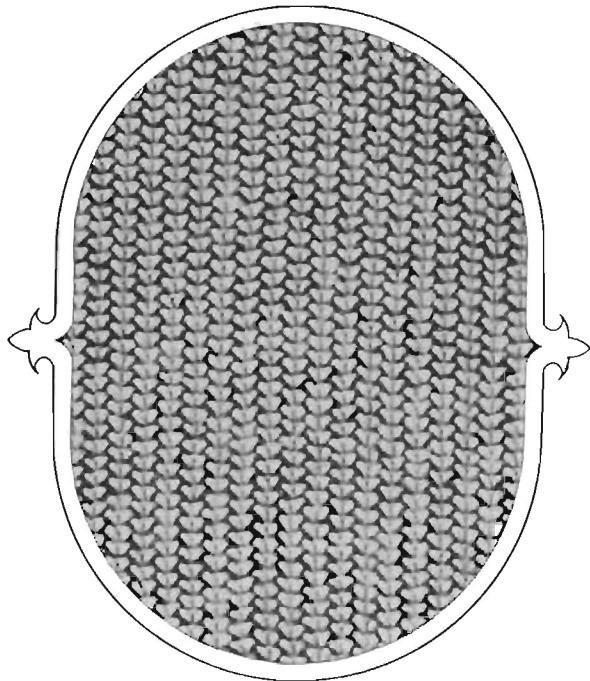

* The added yarn forms on the wrong side of fabric, giving lined look and shows through just enough to produce a tweed effect.

1. The diagram shows the sequence of stitches for the two-thread knitting pattern. The pattern is a 2x2 rib, where every second row and every second column are purl stitches, and all other stitches are knit stitches.

16	15	14	13	12	11	10	9	8	7	6	5	4	3	2	1	24
																23
																22
																21
																20
																19
																18
																17
																16
																15
																14
																13
																12
																11
																10
																9
																8
																7
																6
																5
																4
																3
																2
																1

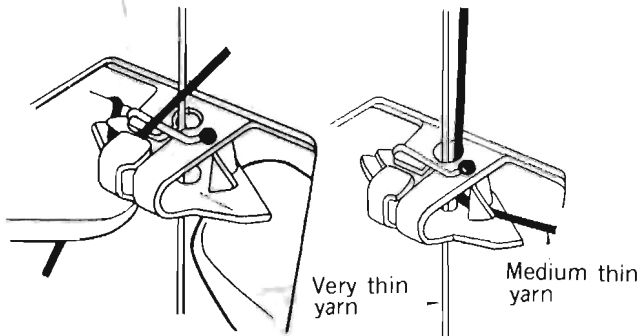

- (1) Thread the main yarn through the yarn feeder and the stranding yarn (lining) through the adding yarn feeder.

The stranding yarn must be passed through the adding yarn feeder from its left side.

* Old ravelling yarn can be used for the stranding yarn.

CARD No. 1 - A TWO THREAD KNITTING <1>					
PAT. RS.	YARN	CAM LEV.	RUSSEL LEV.	SIDE LEV. (BOTH)	D. (RS.)
	2 nd MAIN	STOCKINET	(Blue)	▼	→
		TUCK	(Blue)	▼	→
0		TUCK	(Blue)	▼	→
58		*	*	*	← (59)
STOP	→				

SET STOP KNOB TO ▼ MARK.

ONE PATTERN - 2 STITCHES AND 2 ROWS

Page 62 in the pattern book.

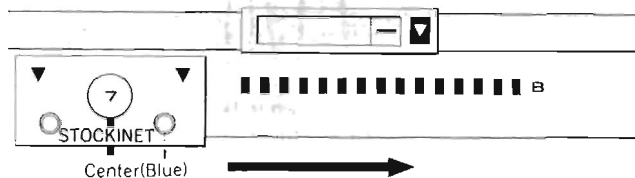

- (2) Insert the punched card No.1-A in the pattern panel and knit one row, following the instructions in the upper — mark line in the operation table. The adding yarn will knit stockinet with the main yarn.
- (3) Set the carriage cam, following the instructions in the operation table and continue knitting until the STOP sign appears in the pattern panel window, and return the card to the — mark.
- (4) Knit one row, following the instructions in the line of the — mark indicated by a red arrow and continue knitting, repeating the process of proceeding from 0 to STOP and back to the — mark indicated by a red arrow.

Note: Thin woolen yarn is recommendable for the adding yarn, since two yarns are knitted at one time.

For example, Medium yarn and very thin yarn.

Thin yarn and very thin yarn.

* Fabric with an interesting look can be knitted by using two different colored thin yarns or fancy yarn.

IF WRONG STITCHES ARE KNITTED

This knitting machine is so designed that the "artificial brain" reads the intended pattern from a punched card and memorizes it. When the carriage is moved, the machine will knit the pattern that has been memorized by the "brain" in the direction in which the carriage moves and at the same time the other "brain" at the rear memorizes the pattern to be knitted next. Even a person who uses this machine for the first time will be able to knit an elaborate pattern very easily.

- * If something wrong took place during the knitting operation, correct it by following the procedures recommended below.

(1) If the Carriage Jammed While Knitting

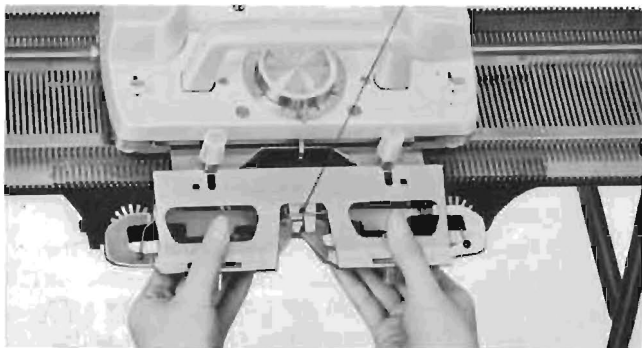

- (1) Loosen the arm nuts and remove the arm from the carriage.

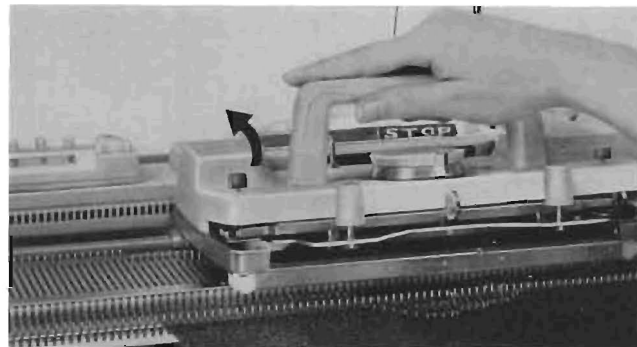

- (2) Lift the front edge of the carriage as shown in the figure. Advance the carriage, holding it in that position. Replace the arm and continue knitting.

- * The needles with the loops which have been pushed behind the latches must be pushed back to the B position, using the accessory transfer tool.

(2) How to Correct Incorrect Knitting

(1) In Stockinet

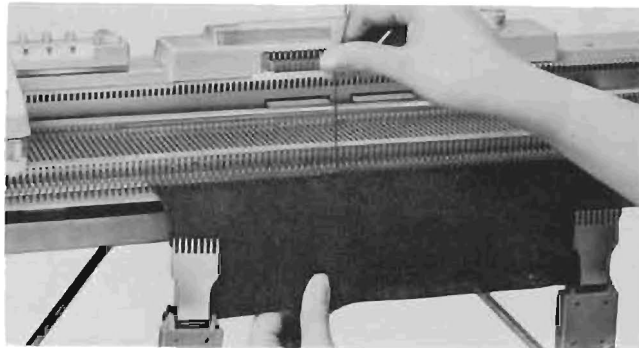

- * Attach the weights to the knitted fabric so that it may be pressed tightly onto the needles. With the left hand pull the fabric downward, unravel all the stitches to be repaired.

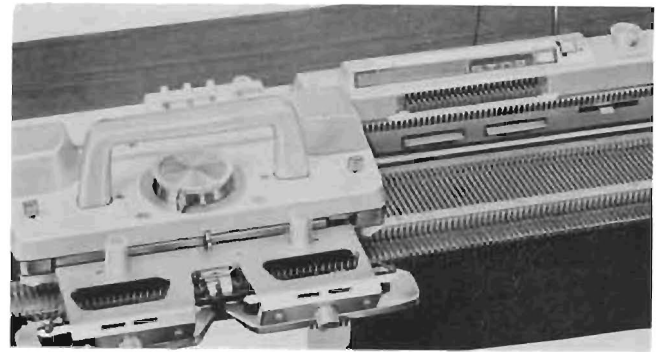

- * If the carriage is on the opposite side of the yarn after ripping rows, set the following controls as instructed.

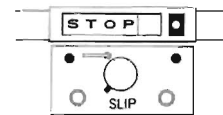

- Cam lever..... Slip
- Side lever..... ● mark on both sides
- Row counter lever... To the side

- * Turn the row counter back by the number of unravelled rows. Set the cam lever back to stockinet and continue knitting.

(2) In Pattern Knitting

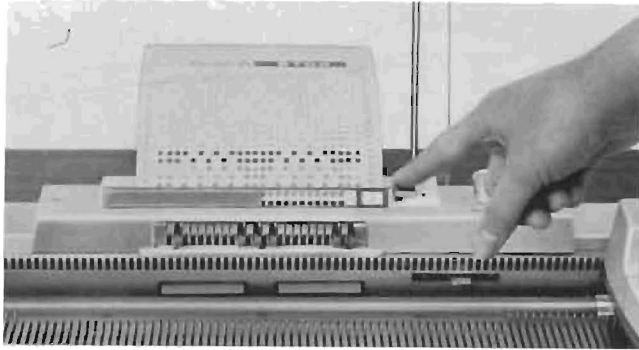

1. First, the relationship between the punched card and the touch lever must be understood.

* Set the stop knob to the solid circle ● mark and the pattern of the punched card will be indicated by the touch lever. The pattern will be knitted by moving the carriage.

Perforated area of card Touch lever rises

Unperforated area of card Touch lever lowers

* If you want to check the pattern in the last row that has just been knitted, turn the card back by one row and set the stop knob to the solid circle ● mark and the pattern you want to check will be indicated by the touch levers.

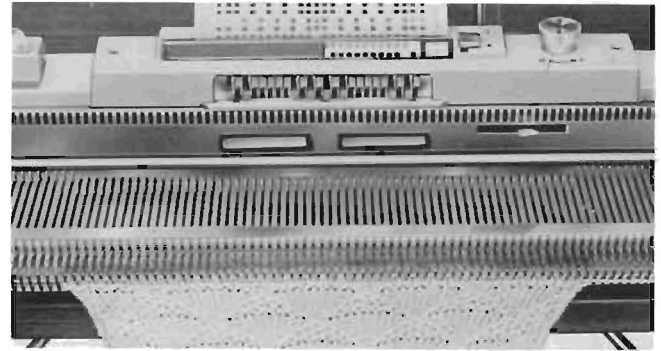

Note: If the stop knob is set to the solid circle ● mark, the feed dial will not move.

WEAVING

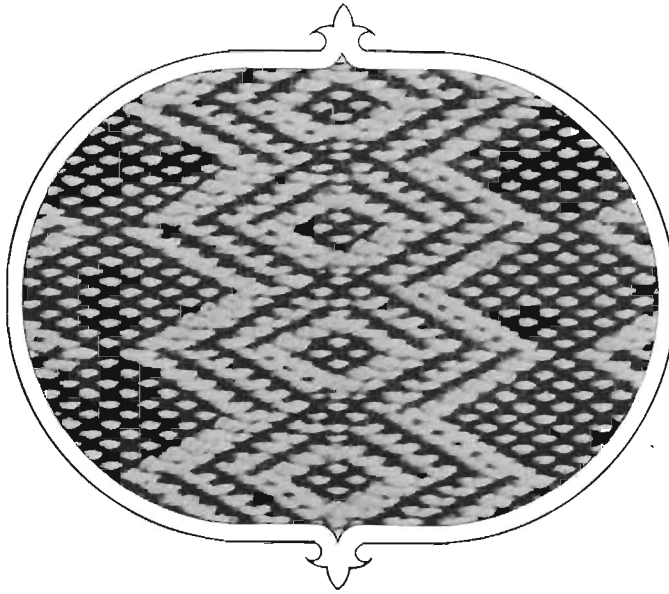

* This is a method in which a different colored yarn or a thicker yarn is knitted into the fabric, bringing the pattern to the wrong side of the material to give it a weaving effect. In this case, a medium yarn is used for the main yarn and a thick yarn for threading.

																							24	
																								23
																								22
																								21
																								20
																								19
																								18
																								17
																								16
																								15
																								14
																								13
																								12
																								11
																								10
																								9
																								8
																								7
																								6
																								5
																								4
																								3
																								2
																								1
24	23	22	21	20	19	18	17	16	15	14	13	12	11	10	9	8	7	6	5	4	3	2	1	



Weaving stitch
Stitches knitted by thread-
ing another yarn through
the fabric.

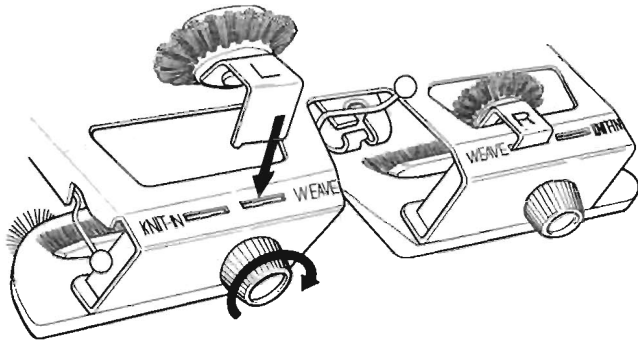

* Install the right auxiliary arm into the right-side auxiliary arm slot (WEAVE) and the left auxiliary arm into the left-side slot and tighten the auxiliary arm nut.

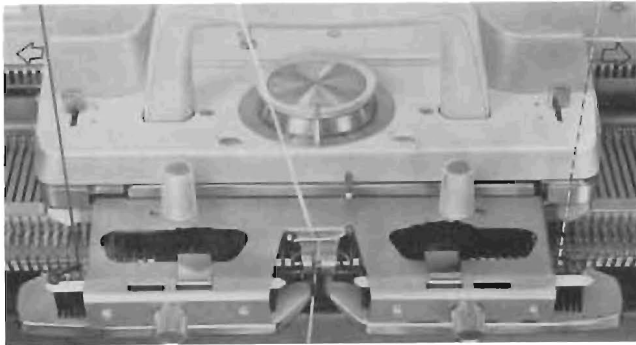

* Thread the main yarn through the yarn feeder and change the threading yarn to the yarn holder on the arm in the direction in which the carriage is to be moved in the same way as in the knit-in pattern.

CARD		No. 14--A		WEAVING <1>	
PAT. RS.	YARN	CAM LEV.	RUSSEL LEV.	SIDE LEV. (BOTH)	D. (RS.)
-	2nd MAIN	Ⓛ	STOCKINET (Blue)	▼	→
0		STOCKINET	(Red)	▼	→
58		"	"	▼	→
STOP					

ONE PATTERN - 24 STITCHES AND 12 ROWS

Page 43 in the pattern book

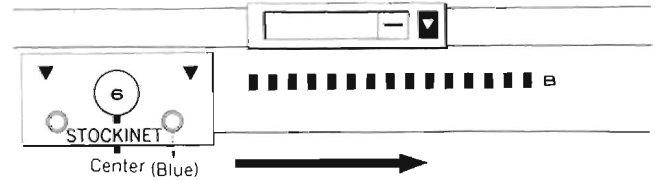

(1) Insert the punched card No.14-A in the pattern panel and set the carriage, following instructions in the upper — mark line. Knit one row with the main yarn coming from the yarn feeder. (This is a row of stockinet before starting pattern knitting)

(4) When Carriage Is Accidentally Pulled off The Rail in the Middle of Pattern Knitting

If the carriage is pulled off the rail in the middle of pattern knitting, the pattern will be dislocated. To make correction, follow the instructions given below.

- Stop knob ● mark
- Cam lever Slip
- Side lever ● mark on both sides
- Row counter lever Turned inside

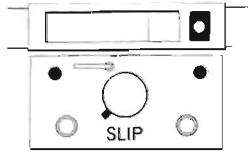

1. After making the above adjustments, move the carriage back and forth.
2. Reset the them to their former positions and knit.

(5) The Needle Selection Marks on the Needle Bed

The needle bed has the × mark and ◇ mark in addition to the numbers that indicate the number of needles.

- × mark... Indicates the center position of the punched card.
- ◇ mark... Indicates the breadth of the pattern on the punched card (24 stitches), 12 stitches on either side of the × mark.

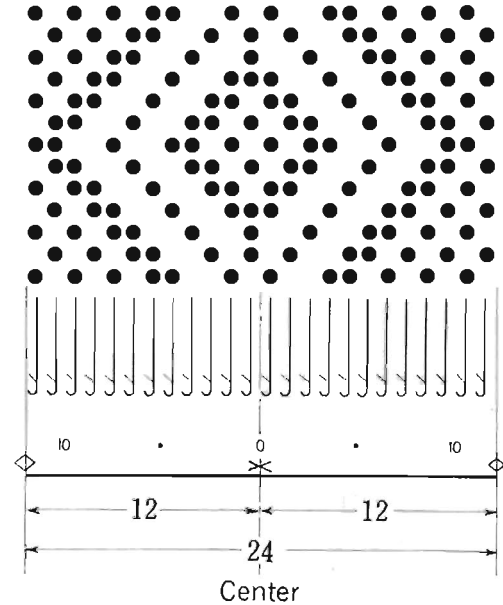



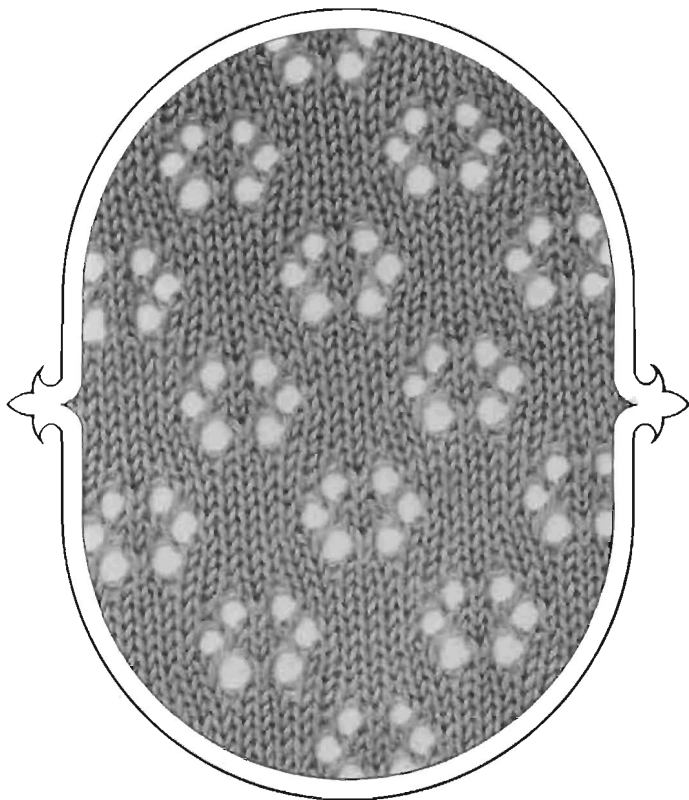

PATTERN KNITTING WITHOUT USING A PUNCHED CARD



LACE KNITTING







																16
																15
			○	↑	○								○	↑		14
		↙	○			○	↘				↙	○				13
																12
				○	↑	○								○	↑	11
																10
																9
																8
																7
↑	○						○	↑	○							6
		○	↘			↙	○			○	↘					5
																4
↑	○							○	↑	○						3
																2
																1
16	15	14	13	12	11	10	9	8	7	6	5	4	3	2	1	

- 

Knit Stitch
Face loop of stockinet
- 

Empty stitch
Hole made by transferring the stitch to the next needle
- 

Two stitches knitted together
Left stitch transferred to right needle
- 

Two stitches knitted together
Right stitch transferred to left needle
- 

Three stitches knitted together
Center stitch on top of left and right stitches

© 1994 by the author. All rights reserved. No part of this publication may be reproduced, stored in a retrieval system, or transmitted, in any form or by any means, electronic, mechanical, photocopying, recording, or by any information storage and retrieval system, without the prior written permission of the author.

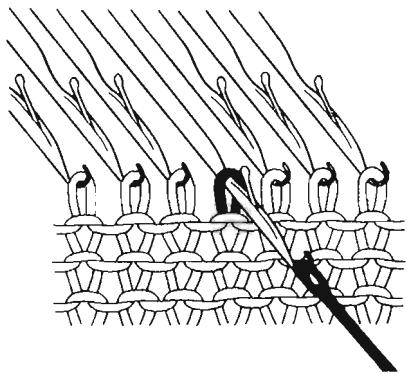

- (1) Knit two rows of stockinet. Use the accessory transfer tool to pull the needle in the position marked with 0 in the pattern chart out to the D position.

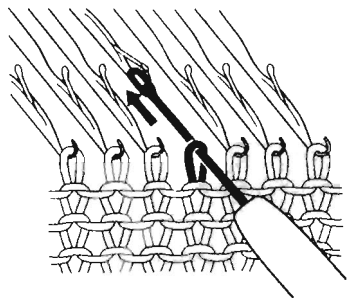

- (2) Push the needle back to its former position and the stitch will slide over the latch onto the transfer tool.

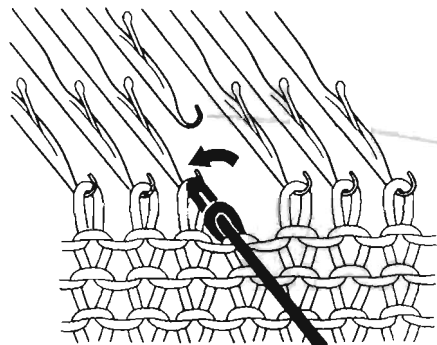

- (3) Transfer the stitch on the tool onto the adjacent needle, following the instructions on the chart.

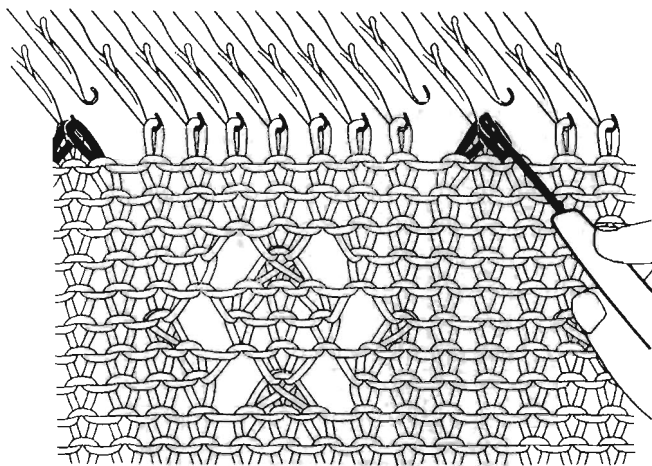

- (4) Repeat the procedures 1 through 3, knitting two rows between each decrease and pulling empty needles back to the B position to knit again.

PATTERN KNITTING WITHOUT USING A PUNCHED CARD

CABLE PATTERN

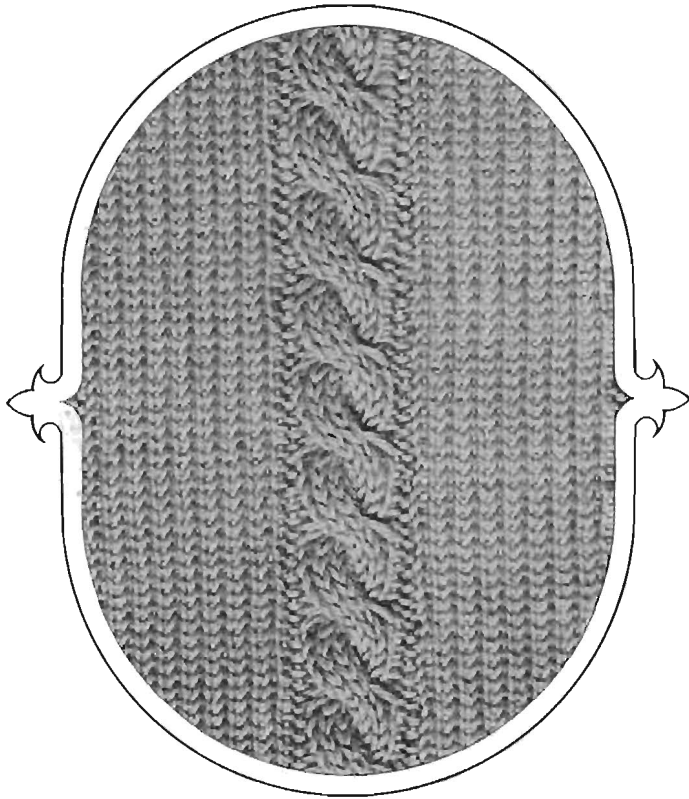

																	14
																	13
																	12
																	11
																	10
																	9
																	8
																	7
																	6
																	5
																	4
																	3
																	2
																	1
16	15	14	13	12	11	10	9	8	7	6	5	4	3	2	1		

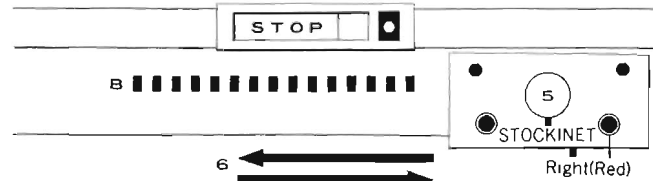
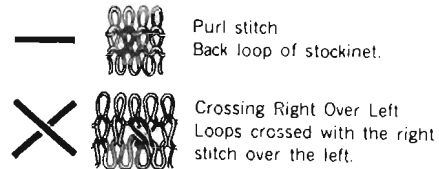

- (1) Set the carriage to stockinet and knit 6 rows.
(More rows can be knitted according to the size of the yarn used.)

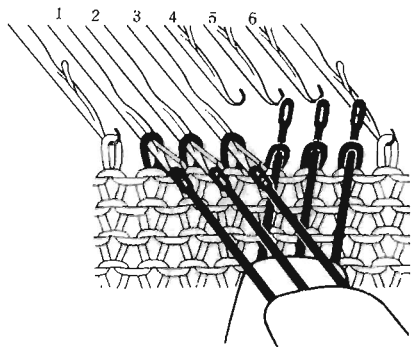

- (2) Use two three-eye transfer tools, Take three stitches off the needles on one transfer tool and the adjacent three stitches onto the other in the same manner.

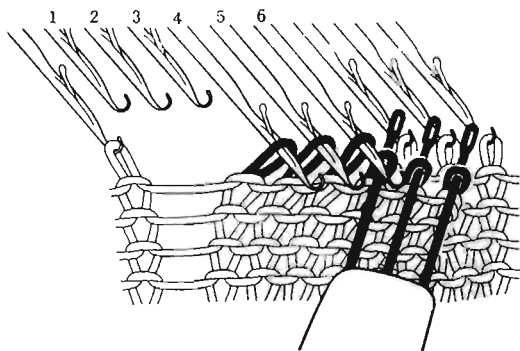

- (3) Move the left-hand group of three stitches to right and the righthand group to left so that they cross each other.

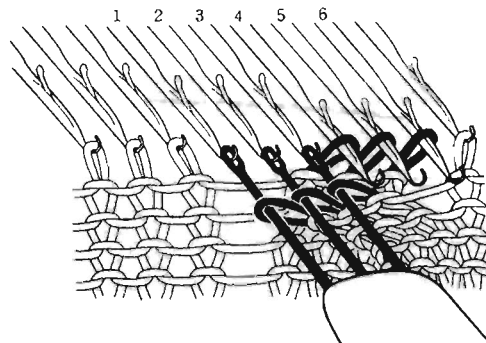

- (4) Hook the stitches onto the empty needles.

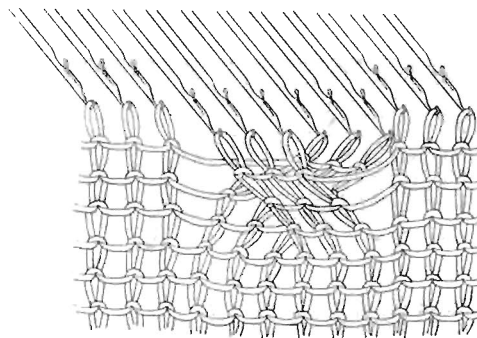

- (5) Pull the six needles to the D position with Russel lever to red, and knit six rows.

- (6) Repeat the above procedures, crossing in the same direction each time. Rib stitches on each side of the knitted "rope" approximately every 15th row.

* Refer to purling stitches (ribbing) in the following section.

RIBBING

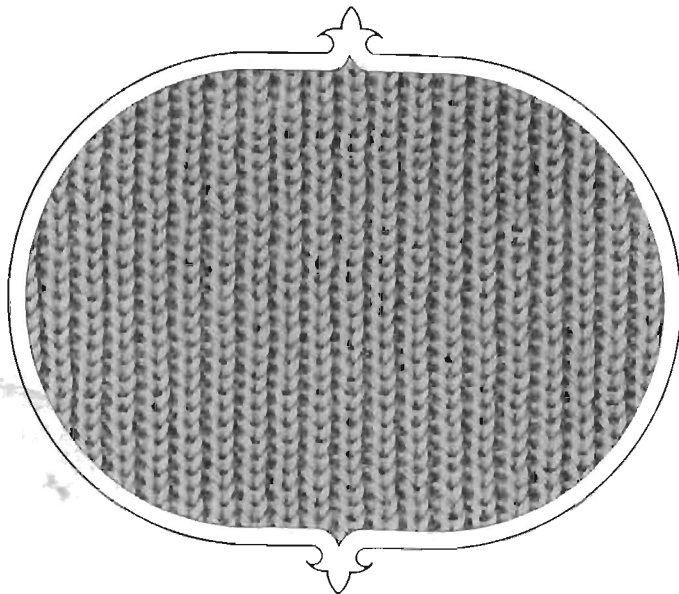

—		—		—		—		—		—		—		—		—		—		12
—		—		—		—		—		—		—		—		—		—		11
—		—		—		—		—		—		—		—		—		—		10
—		—		—		—		—		—		—		—		—		—		9
—		—		—		—		—		—		—		—		—		—		8
—		—		—		—		—		—		—		—		—		—		7
—		—		—		—		—		—		—		—		—		—		6
—		—		—		—		—		—		—		—		—		—		5
—		—		—		—		—		—		—		—		—		—		4
—		—		—		—		—		—		—		—		—		—		3
—		—		—		—		—		—		—		—		—		—		2
—		—		—		—		—		—		—		—		—		—		1
12	11	10	9	8	7	6	5	4	3	2	1									

(1) Set the stitch dial one number lower than for stockinet.

Note: If the yarn used is very thin, set the dial two numbers lower.

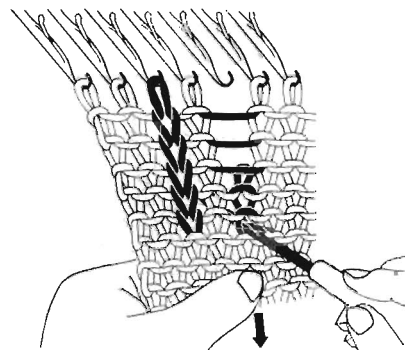

(2) Knit stockinet for the desired amount of ribbing. Insert the latch of tappet through the loop that begins the ribbing and drop the stitch from the third latch needle by pulling to the D position and then pushing back to the B position. Use tool or finger to release the dropped stitches.

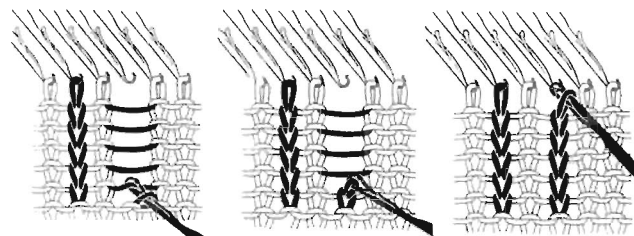

(3) Repeat the operations shown in the above figures and transfer the last stitch onto the latch needle.

GARTER STITCHES

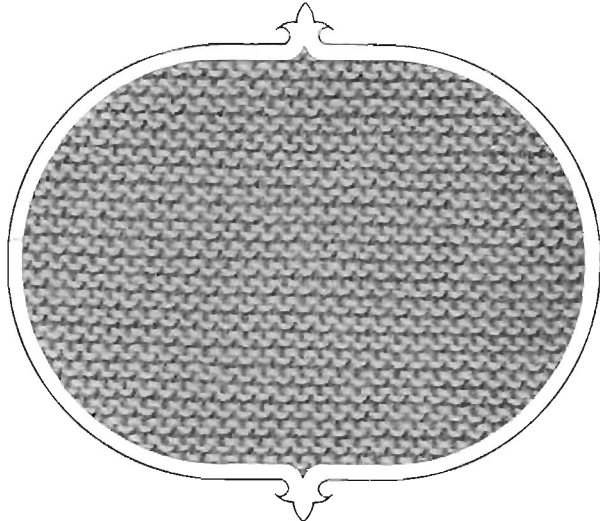

-	-	-	-	-	-	-	-	-	-	-	-	12
												11
-	-	-	-	-	-	-	-	-	-	-	-	10
												9
-	-	-	-	-	-	-	-	-	-	-	-	8
												7
-	-	-	-	-	-	-	-	-	-	-	-	6
												5
-	-	-	-	-	-	-	-	-	-	-	-	4
												3
-	-	-	-	-	-	-	-	-	-	-	-	2
												1
12	11	10	9	8	7	6	5	4	3	2	1	

- (1) Set the stitch dial one number lower than for stockinet knitting.
- (2) Knit two rows.

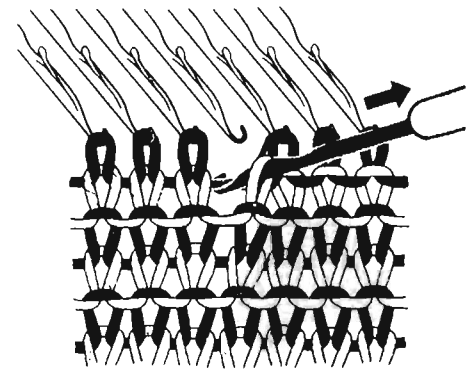

- (3) Open the latches of all needles and purl (rib) all the stitches of the second row with the tappet.
- Note: The garter bar is a hand tool to transfer all stitches at once without the use of the tappet. The use of this tool makes the operation much easier and speedier.

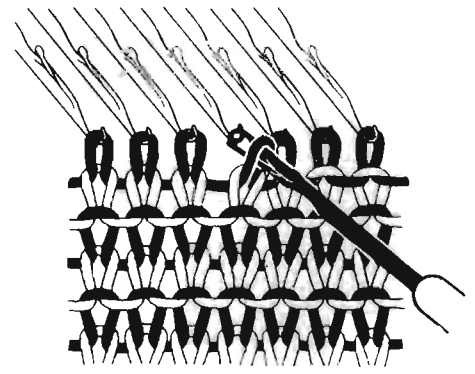

- (4) Repeat the procedures (2) and (3).

PATTERN KNITTING WITHOUT USING A PUNCHED CARD

GROUND DESIGN WITH FACE LOOPS AND SOLID PATTERN

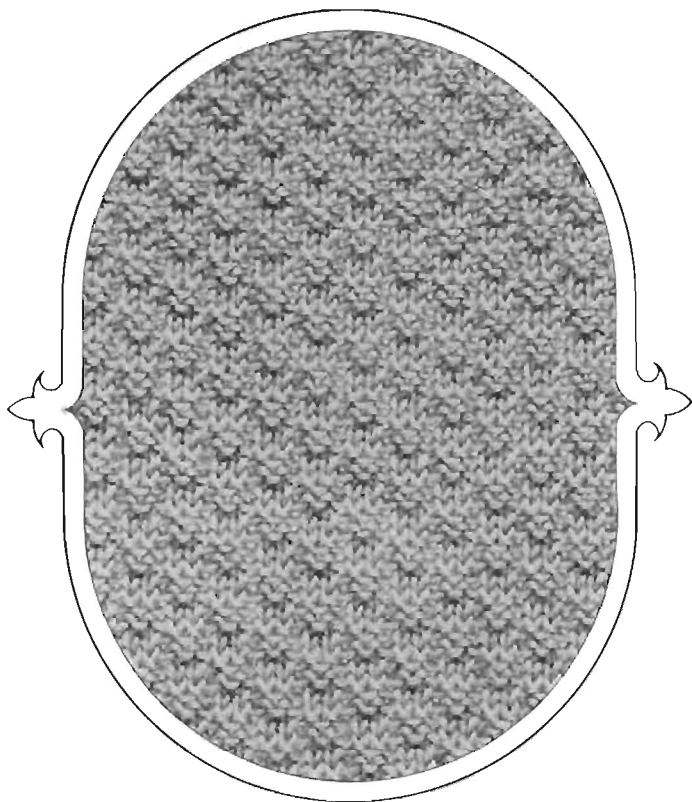

		-	-			-	-			-	-	12
		-	-			-	-			-	-	11
-	-			-	-			-	-			10
-	-			-	-			-	-			9
		-	-			-	-			-	-	8
		-	-			-	-			-	-	7
-	-			-	-			-	-			6
-	-			-	-			-	-			5
		-	-			-	-			-	-	4
		-	-			-	-			-	-	3
-	-			-	-			-	-			2
-	-			-	-			-	-			1
12	11	10	9	8	7	6	5	4	3	2	1	

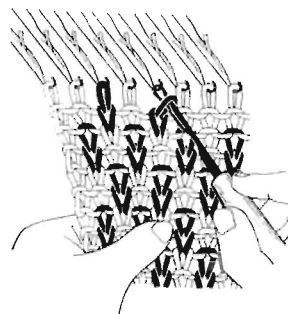

- (1) Knit two rows.
- (2) Refer to the pattern chart, drop the stitches marked (■), and purl them with the tappet.
- (3) Repeat the procedures (1) and (2).

CORDING

* This method is used for knitting the cords for a cape, a hood or belt.

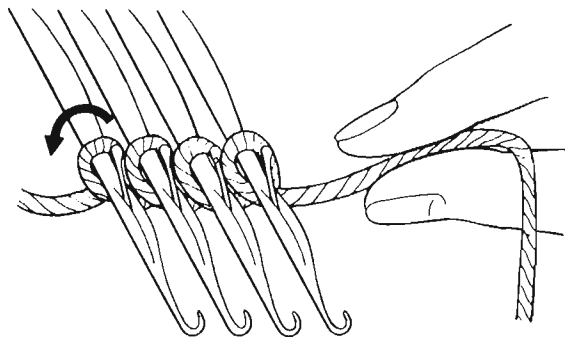

(1) Pull to D position 3 to 5 needles depending on thickness of the cord to be made. Form stitches by making loops around the needles as shown in the above figure.

(2) Set the stop knob and the carriage controls as instructed below.

Stop knob ● mark (stockinet card should not be used)

Cam lever Slip

stitch dial 1 ◦ 2 (medium yarn)

Side lever..... Forward = ▼ mark
Backward = ● mark

Russel lever Red (Right)

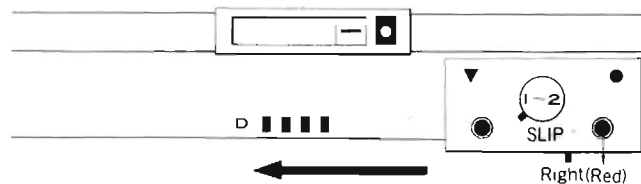

(3) Knit a row, moving the carriage back and forth. Next, bring the needles out to the D position, holding the knitted cord in fingers.

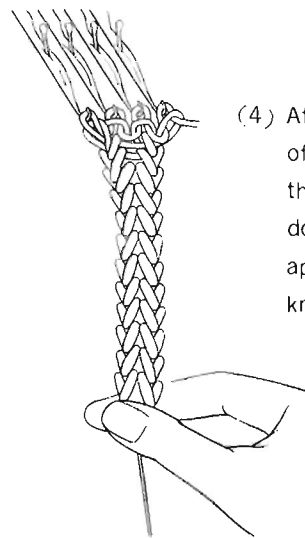

(4) After repeating the procedure of (3) about five times, move the carriage while a gentle downward pressure is being applied on the tail of the knitted cord.

5. METHOD OF PARTIAL KNITTING

* Knitted fabric is shaped not by cutting as in the case of woven materials but by partially decreasing or increasing the stitches to narrow or broaden the fabric.

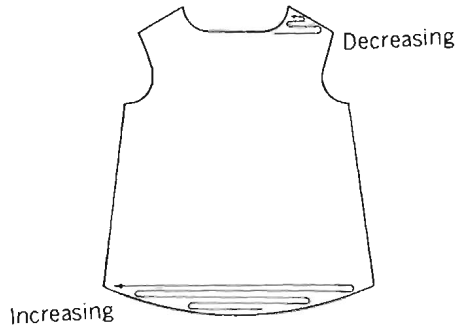

Note: * For partial knitting, the Russel lever must be set to CENTER (Blue). Be sure that the lever is set correctly because if you knit with the lever remaining at RIGHT (Red) the needles rested in the D position will be knitted in.

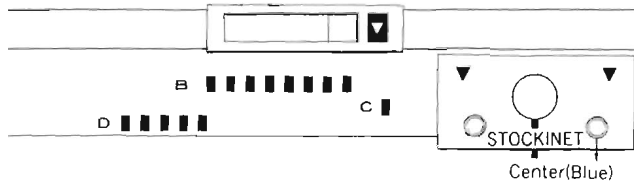

- * For thread knitting, the end latch needle is brought to the D position. For partial knitting, however, it must be pulled to the C position.
- * Cam lever and side levers must be set correctly in the positions specified for the types of pattern to be knitted.

* Decreasing Stitches

In both stockinet and pattern knitting, set the cam lever and side levers as required by the type of knitting and the needles that are to be rested to drop stitches must be brought to the D position. Continue knitting, following the instructions given below.

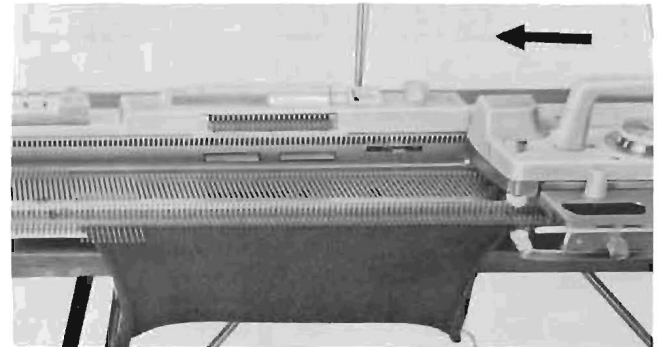

- (1) Bring the needles on the opposite side of the carriage, which are not used, to the D position and operate the carriage to knit one row.
(The needles in the B position knits the yarn. The needles in the D position remain idle and the yarn passes over them.)

brought
ever, it

ectly in
n to be

m lever
ing and
is must
follow

e car-
n and

The
yarn

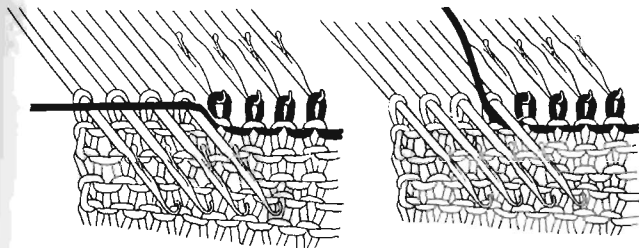

- (2) To prevent a hole from being formed in the fabric, pass the yarn under the first resting needle and then over the other needles.

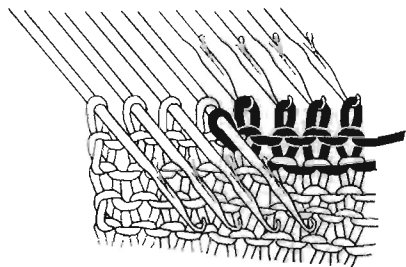

- (3) Knit one row by moving carriage backward.

This completes the first operation for partial knitting.

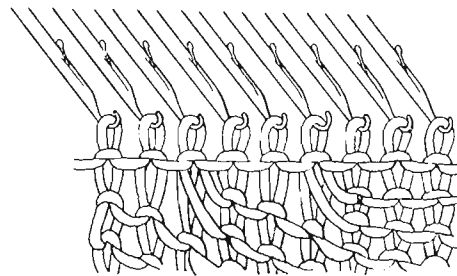
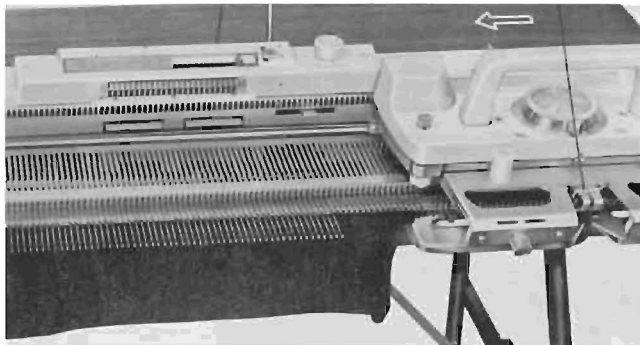

- (4) Repeat the procedures (2) and (3), bringing an increasing number of needles to the D position.

After completion of partial knitting, set the Russel lever to right (red) and knit one row. All the needles in both B and D positions have worked and they are all lined up in the B position.

* Increasing Stitches

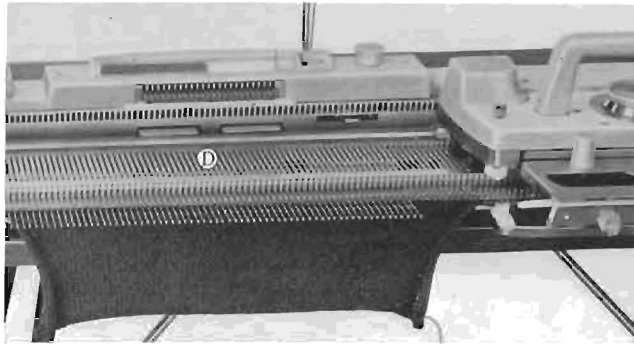

Knit returning a desired number of needles, which have been rested in the D position, to the position where they can be operated.

There are two methods, as explained below, for bringing the needles back to operation.

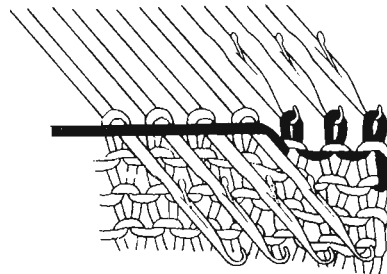

(1) In Stockinet and Knit-in

(1) Bring the first latch needle on the side of the carriage to the B position and other needles to the D position. Knit one row.

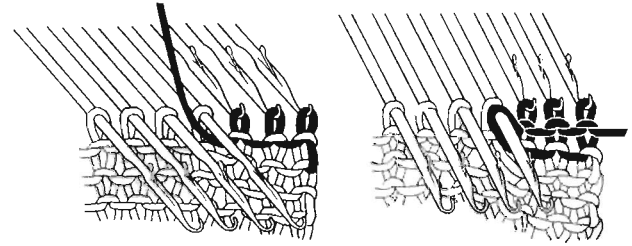

(2) To prevent a hole from being formed in the fabric, pass the yarn under the first resting needle and then over other needles.

(3) Knit one row.

This completes the first operation for partial knitting.

(4) Push a desired number of the needles, which have been rested in the D position, back to the C position and knit three rows.

(When the needles are pushed back to the B position, be sure that they are correctly positioned within the range marked by the sign \uparrow .)

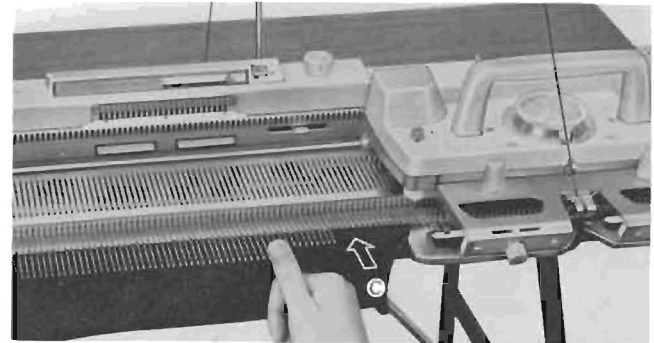

(5) Repeat the procedures (2) through (4) for a desired number of rows.

(2) In Tuck knitting, Tuck slip stitches and weaving.

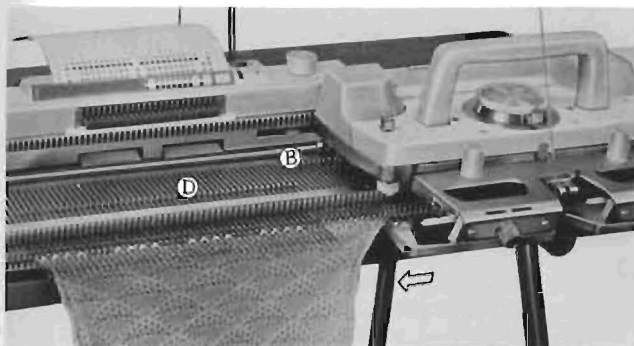

The number of needles brought to the D position is increased gradually while knitting. For plain knitting, the needles are pushed back to the B position, using the transfer tool.

(The same method for Tuck knitting can be used for Lace knitting and Two thread knitting.)

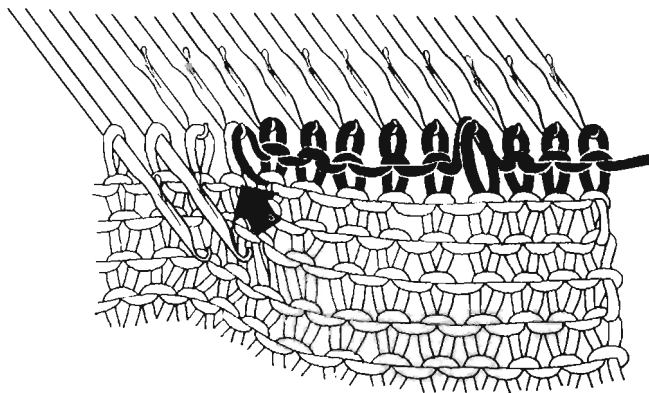
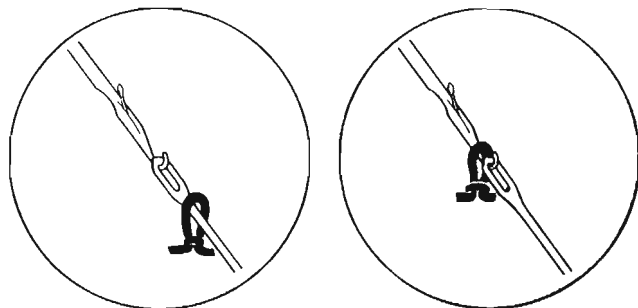

6. CORRECTION OF TROUBLES

* Replacement of Broken Needle

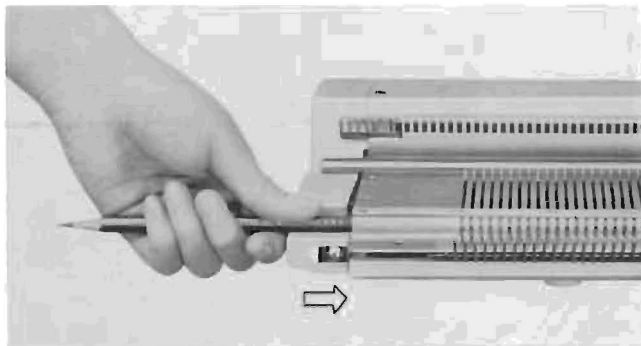

(1) Push the needle retainer under the needle bed out in either direction, using a pencil or screw driver.

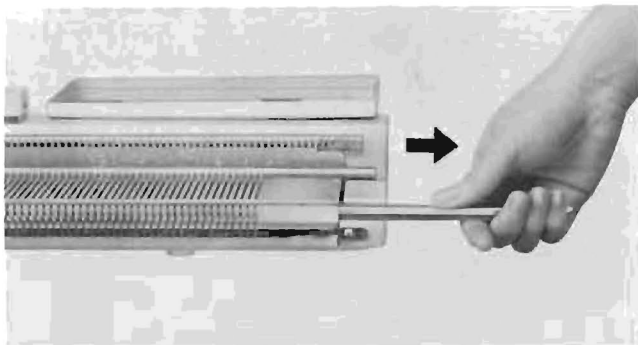

(2) Pull the needle retainer out until it is clear from the needle to be replaced.

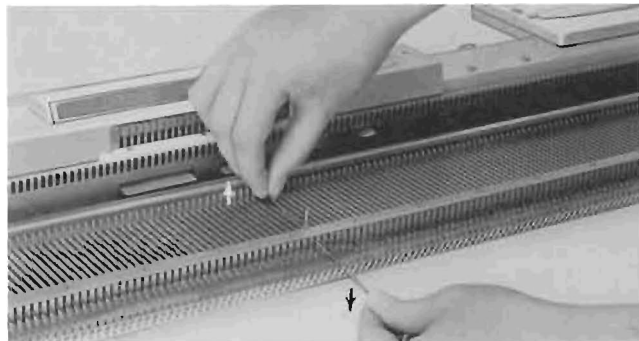

(3) Pull the damaged needle to the D position. Push the latch downward and the shank will come out of the needle bed. Pull the needle off the needle bed, lifting the shank upward.

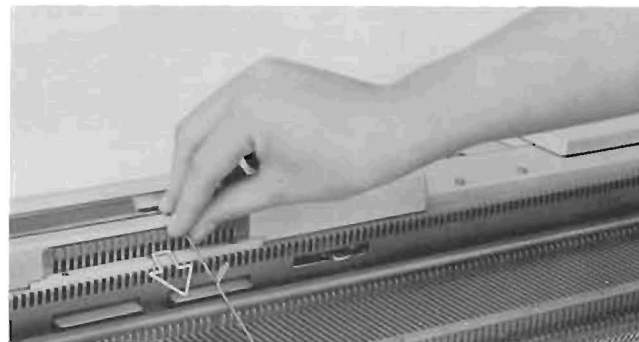

(4) To install a new needle in the needle bed, hold the butt in fingers and slip the needle in, latch end first, reversing the order in (3). And push the needle retainer back into its former position.

* The Yarn Getting Loose or Entangled at the End of Fabric

* Loose Yarn

Check to see that the yarn is correctly threaded through the auto-tension.

* Entangled Yarn

If the yarn get stuck in any part of the machine, it will impair the properly operation of the machine.

The yarn must be placed clear of the machine while it is operated to prevent such a mishap.

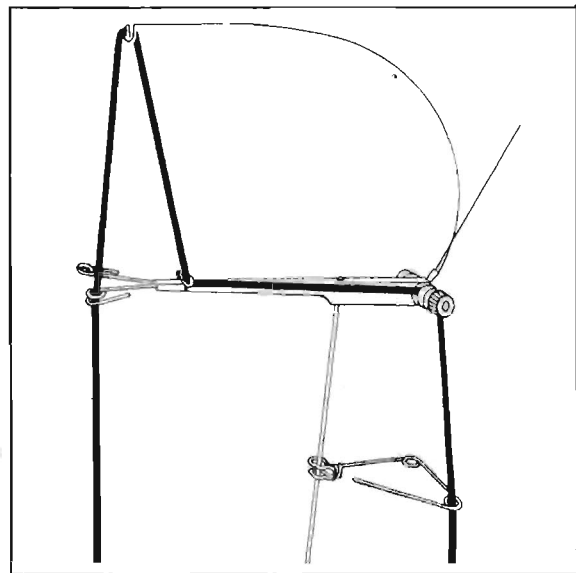

* The Yarn Getting Entangled in the "Artificial Brain"

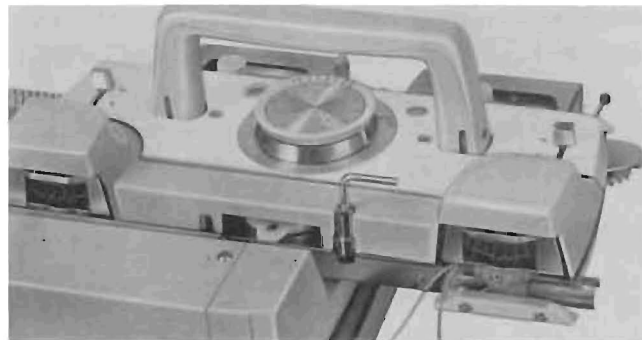

(1) When the yarn has gotten entangled on the gear wheel of the "artificial brain", shift the carriage to the side of the machine as shown in the above figure.

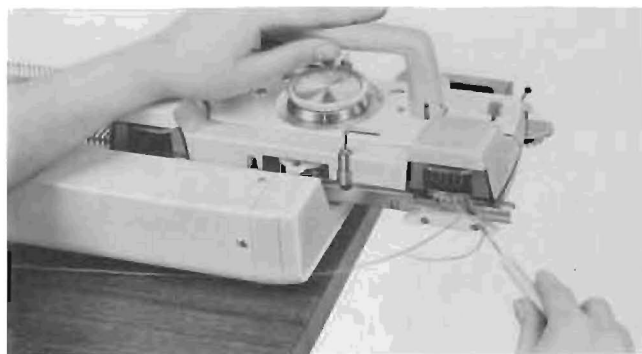

(2) Carefully disentangle the yarn, using the tappet.

7. MAINTENANCE INSTRUCTIONS

Any kind of machine needs proper cleaning and lubrication, if it is to have a long usable life. Make sure that this knitting machine is always kept clean and well lubricated if you want to use it in good working condition for a long time.

Lubrication

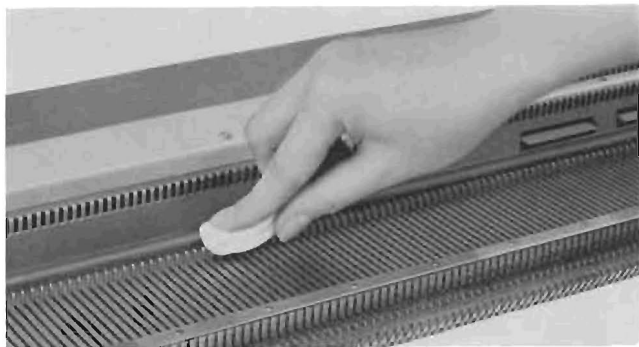

(1) Wipe the butts of the needles with a piece of oiled cloth.

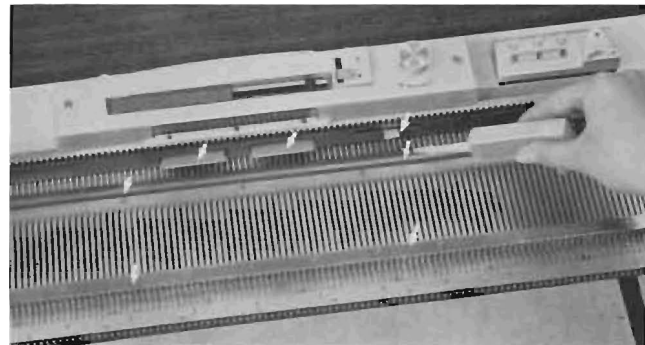

(2) Apply the lubricant drop by drop to the places marked with arrows. Move the carriage back and forth several times and the oil will spread all over the needle bed.

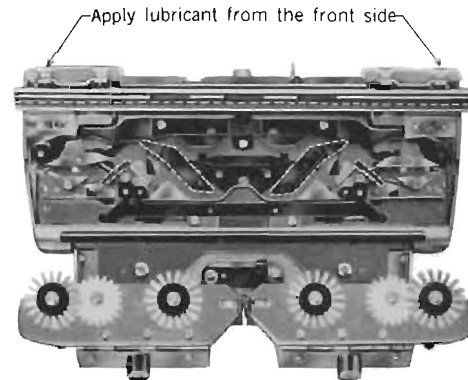

(3) Wipe the place indicated by a dotted line with a piece of oiled cloth.

* After-Operation Maintenance Services

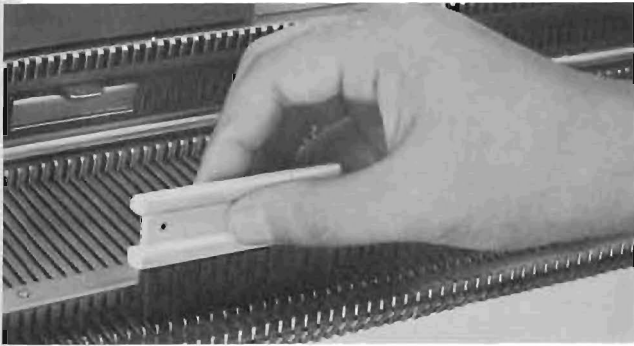

- (1) Use the accessory brush to remove tiny fragments of woolen yarn from all parts of the machine.
- (2) Carefully wipe all the metal parts with an oiled cloth to remove dust and dirt.

* Cleaning of the Case

The case can be made clean by wiping with a piece of cloth saturated with synthetic detergent.

* Storage

After being carefully cleaned, store the machine in a dry place.

Method for Detaching the Knitting Machine Body From the Case

- (1) Turn the machine upside down and remove the two screws located between the rubber feet on the backside of the case.

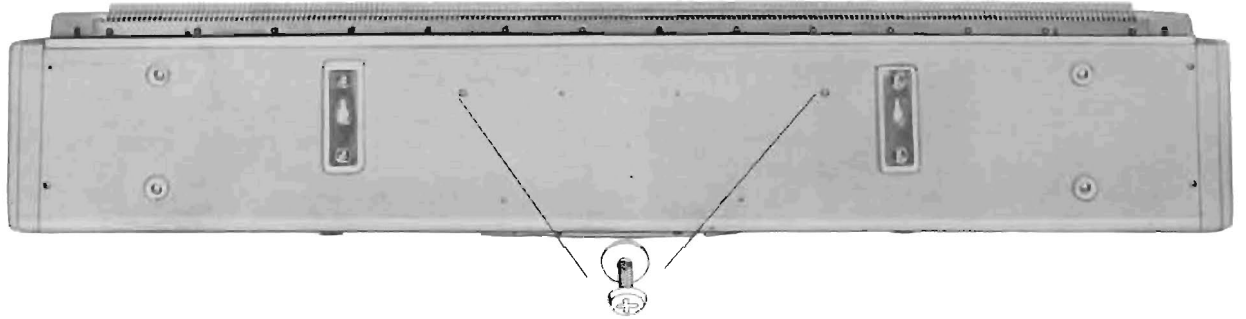

- (2) Remove the four screws holding down the needle bed and the needle bed will readily come off the case.

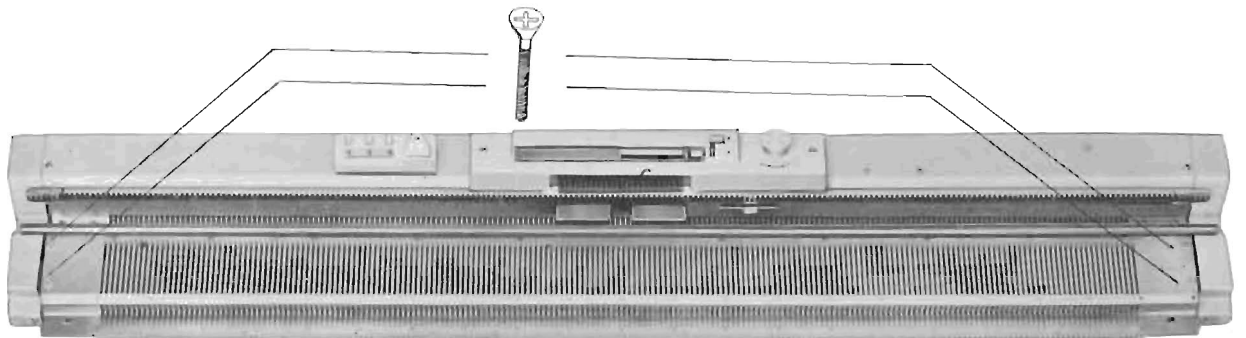

8. HOW TO PACK THE MACHINE AWAY

- (1) Remove the punched card from the pattern panel while turning the feed dial.
 - * Special care is needed not to fold or tear the card.
- (2) Replace all the accessories in the accessory box in an orderly manner as they were originally packed.
 - * The auxiliary arm brushes must be be placed in the correct position so that they may not be damaged.

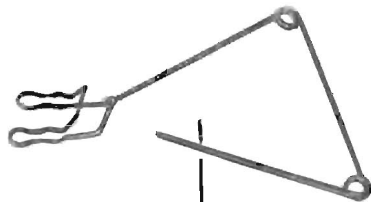
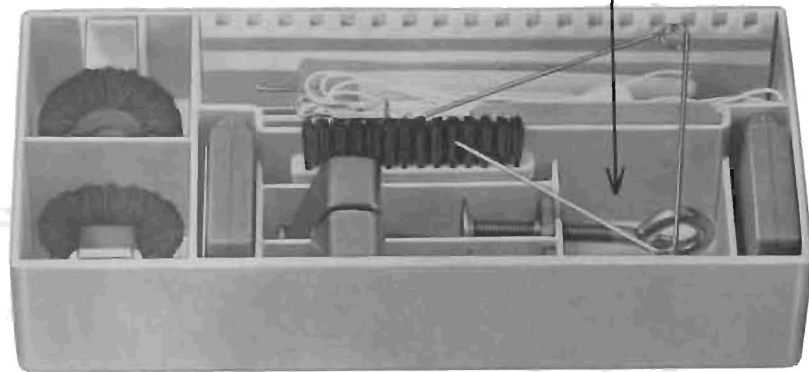
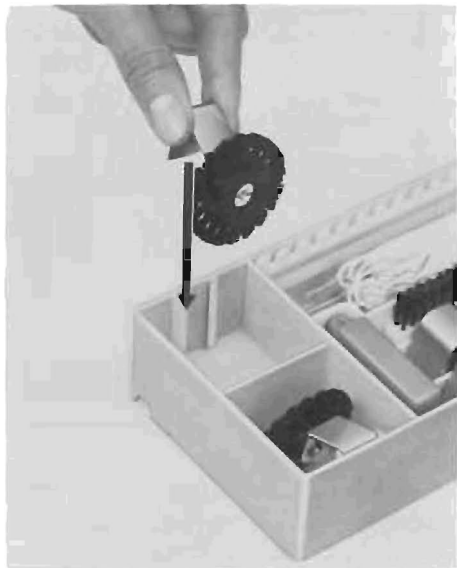

(3) Arms, auto-tension and yarn rod must be placed in the inside of the cover in the order of (1), (2), (3), (4), (5) and (6) as shown in the figure.

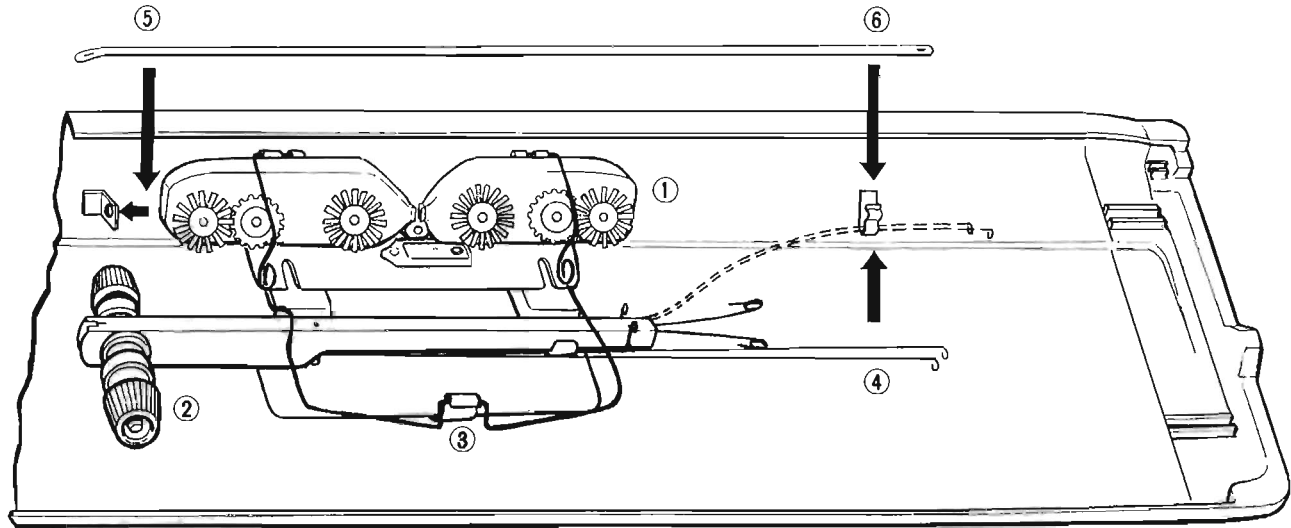

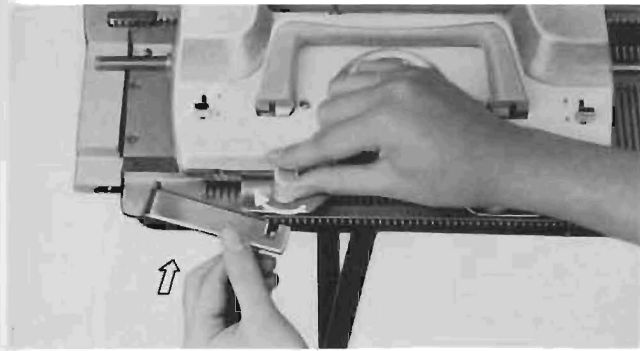

(4) Replace the carriage fastener to lock the carriage securely and fold the handle of the carriage.

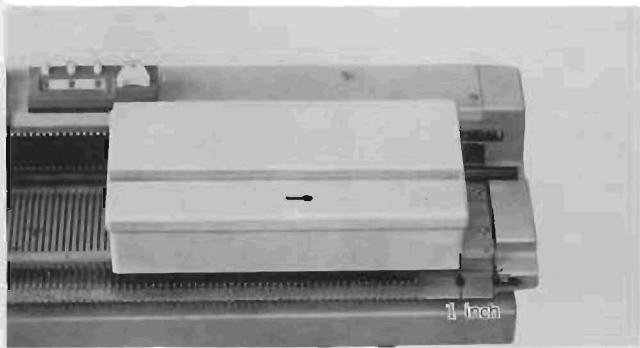

(5) Place the accessory box on the needle bed so that it may be about one inch clear of the right end of the needle bed.

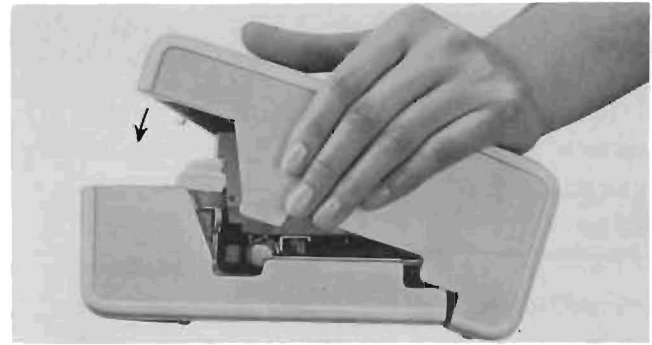

(6) Replace the cover.



(7) Fasten the latches.

SERIES OF PUNCHED CARDS FOR SALE SEPARATELY

To give you a broader selection of punched cards to choose from there has been eleven series placed on sale. Each series contains ten punched cards.

Series are classified into those of solid pattern, colored pattern, etc., respectively representing the series. Besides these representative patterns, each series includes other types of knitting too.

- Series No. 21 Solid pattern
- Series No. 22 Colored pattern
- Series No. 23 Lace knitting
- Series No. 24 Knit-in, large pattern
- Series No. 25 Knit-in, large pattern
- Series No. 26 Knit-in, large pattern
- Series No. 27 Knit-in, small pattern
- Series No. 28 Weaving, large pattern
- Series No. 29 Weaving, small pattern
- Series No. 30 Knit-in, special pattern
- Series No. 31 Knit-in, special pattern



— MEMO —

— MEMO —

— MEMO —

— MEMO —

ACC

R

N

Transfe

Spa

Tap

Cro

ACCESSORIES



Yarn rod



Auto tension

Ravelling Cord



Needle pusher



Transfer tools 1-2



2-3



1-3



Tappet



Weights



Auxiliary arms



Spare needles (3)



Tapestry needle



Crochet hook



Tension guide



Oil



Carriage fastener



Brush



Stockinet card



Clamps



Accessory Holder



Accessory case

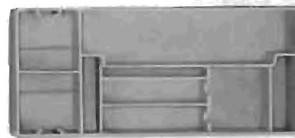

Punched card

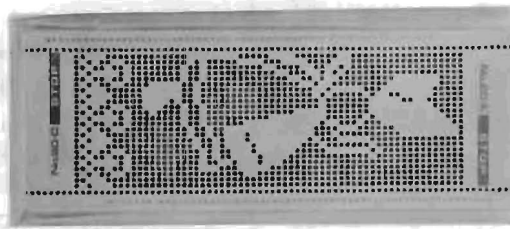

Pattern book



CONTENTS

1. Assembling procedures	1	Pattern knitting without using a punched card	40
2. Preparations for knitting	6	Lace knitting	40
3. Casting on and stockinet knitting	10	Cable pattern	42
4. Patterned knittings	14	Ribbing	44
How to read the punched card	14	Garter stitches	45
PATTERN BOOK	15	Ground design with face loops and solid pattern ...	46
How to read the operation table	16	Cording	47
Preparations for Knitting a Pattern	17	5. Method of partial knitting	48
Tuck knitting	18	Decreasing stitches	48
Tuck slip stitches	21	Increasing stitches	50
Knit-in	24	6. Correction of troubles	52
Weaving	27	Replacement of Broken needle	52
Lace knitting	30	The yarn getting loose	
Two thread knitting	32	or entangled at the end of fabric	53
If wrong stitches are knitted	34	The yarn getting	
(1) When the carriage		Entangled in the "artificial brain"	53
failed to move while knitting	34	7. Maintenance instructions	54
(2) How to correct incorrect knitting	35	* Lubrication	54
1. In stockinet	35	* After-Operation Maintenance Services	55
2. In pattern knitting	36	* Cleaning of the case	55
(3) Knitting Beyond		* Storage	55
STOP sign on the punched card	38	* Method for detaching	
(4) When Carriage is accidentally pulled off		the knitting machine body from the case	56
the rail in the middle of a pattern knitting... ..	39	8. How to pack the machine away	57
(5) The needle selection mark on the needle bed ..	39		