

# SERVICE MANUAL FOR KE-100



**brother**<sup>®</sup>

# 1. SPECIFICATIONS

## CONTENTS

1. SPECIFICATIONS .....	1
2. QUICK TROUBLE SHOOTING CHART .....	2
3. NOTES FOR CHECK AND REPAIR .....	4
4. CIRCUITRY CONFIGURATION .....	5
5. DISASSEMBLING FOR EASY CHECKING .....	7
6. REMOVING THE MOTOR HEAD .....	8
7. DISASSEMBLING THE MOTOR HEAD .....	9
8. ASSEMBLING THE MOTOR HEAD .....	15
9. REMOVING THE AC POWER CORD .....	23
10. REMOVING THE SHUTTLE ASSEMBLY .....	24
11. HOW TO REPLACE THE DRIVING BELT .....	25
12. DISASSEMBLING AND ASSEMBLING THE SHUTTLE BASE ..	26
13. MOUNTING THE SHUTTLE BASE AND THE MOTOR HEAD ..	26
14. ADJUSTING THE TENTION OF DRIVING BELT .....	28
15. CHECKING THE FUNCTION OF THE ROW COUNTER .....	29
16. CHECKING THE ELECTRONIC PARTS .....	30

Operation range	30-124 cm
Operation speed	H: 28 courses/min. (180 stitches) (50Hz) L: 20 courses/min. (180 stitches) (50Hz)
Torque;	10 kg
Function	Operation range control (1st-200sts)
	Operation speed control (High/Low)
	Operation mode control (Continuous/Intermittent)
	Preset row conter (0000-9999) Max: 10000 rows
Others	Overload stopping system Yarn run out sensor, Knot sensor
Motor	Output 100W Power consumption 200W
Electricity	100V/60Hz, 117V/60Hz, 220V/50Hz, 240V/50Hz
Weight	17 kg (including the stand)

## 2. TROUBLE SHOOTING

Trouble	Cause	Repair	Notes
1. The Direction indicator lamp never light on and can not start the Motor by pushing the S/S switch	1. The plug of AC power cord is not inserted into the power suply socket correctly.	1. Connect the plug firmly.	
	2. Poor connection of the connector P1, CN1, or CN6.	2. Connect P1, CN1, CN6 firmly.	
	3. Disconnection of Ac power cord.	3. Replace the AC power cord.	
	4. Poor connection or broken of the AC power switch.	4. Replace the AC power cord.	
	5. Blown of the fuse. (F1 and/or F2)	5. Replace the fuse.	
	6. Troubles on the Main P.C.B..	6. Replace the Main P.C.B..	
2. Both of the direction indicator lamps are flashing and you can not start the Motor by pushign the S/S switch:	1. Poor connection of the connector P2 or CN2.	1. Connect P2 or CN2 firmly.	
	2. Disconnection of the stator windings of motor.	2. Replace the Motor.	
	3. Trouble on the Main P.C.B..	3. Replace the Main P.C.B..	
3. The motor never run by pushing the S/S switch though the direction indicator lamp lights correctly.	1. Troubles on the S/S switch of the control switch P.C.B..	1. Replace the control switch P.C.B..	
	2. Troubles on the Main P.C.B..	2. Replace the Main P.C.B..	
4. The motor (Shuttle) runs only in the one direction.	1. Troubles on the Main P.C.B..	1. Replace the Main P.C.B..	
5. The motor stops as if the motor is in the over load condition though the motor is in non load condition.	1. Poor connection of the connector P2.	1. Connect P2 firmly.	
	2. Disconnection of the stator windings of the motor.	2. Replace the Motor.	
	3. Troubles on the encorder P.C.B..	3. Replace the Encorder P.C.B..	
	4. Troubles on the Main P.C.B..	4. Replace the Main P.C.B..	
6. Though the Operation mode switch is set on the continuous mode and the number on the Row counter is not ZERO (0), the Motor stops on every row and the L and R lamps light alternately.	1. Troubles on the Main P.C.B..	1. Replace the Main P.C.B..	
	2. Broken of the Row counter switch.	2. Replace the Row counter.	
7. The motor (shuttle) runs only in the one direction regardless of the setting position of Operation knob.	1. Poor connection of the connectors CN7, CN8R and CN9L.	1. Connect every connector firmly.	
	2. Troubles on the Main P.C.B..	2. Replace the Main P.C.B..	
	3. Troubles on the left range sensor P.C.B. (not turns from the left to the right) or Right range sensor P.C.B. (not turn from the right to the left).	3. Replace the Right or Left range sensor P.C.B..	
	4. Troubles on the Control switch P.C.B..	4. Replace the Control switch P.C.B..	
8. The direction indicator lamp(s) never light on though the motor runs in order.	1. Broken of the Lamp (LED).	1. Replace the Control switch P.C.B..	
	2. Troubles on the Main P.C.B..	2. Replace the Main P.C.B..	
9. When the Power switch is turned on, both Direction indicator lamps light simultaneously.	1. Troubles on the Main P.C.B..	1. Replace the Main P.C.B..	

Trouble	Cause	Repair	Notes
10. When turning on the Power switch, the left direction indicator lamp flashes on and off and the motor does not run by the S/S switch.	1. The Speed change knob is not shifted correctly.	1. Reset the speed change knob.	
	2. The dropped Yarn sensor and/or the leaped up yarn sensor prevent the motor running.	2. Set the Yarn sensor lever and/or the Yarn knot sensor plate to the normal position.	
	3. The Jam sensor is under the sensible conditions.	3. Check up the Jam sensor.	
	4. Troubles on the Main P.C.B..	4. Replace the Main P.C.B..	
11. The Direction indicator lamp for the direction that the shuttle is going to flashes on and off and the motor does not run by the S/S switch.	1. The yarn sensor and/or the Jam sensor is under the sensible conditions.	1. Check up the Yarn sensor and the Jam sensor.	
	2. The speed change knob is not shifted correctly.	2. Reset the Speed change knob.	
	3. Troubles on the Main P.C.B..	3. Replace the Main P.C.B..	
12. The shuttle moves only one row though the operation mode selector knob is set on the continuous operating position.	1. Broken of the operation mode selector switch.	1. Replace the Control switch P.C.B.. ✕	
	2. Poor connection of the connector CN6. (In this case the direction indicator lamps do not light.)	2. Connect CN6 firmly.	
	3. Troubles on the Main P.C.B..	3. Replace the Main P.C.B..	
13. The turning position of the Shuttle fluctuates in the continuous operation mode.	1. Troubles on the Main P.C.B..	1. Replace the Main P.C.B..	
14. The motor never stop even if the number on the Row counter comes to zero (0).	1. Poor connection of the connector CN4.	1. Connect CN4 firmly.	
	2. Broken of the Row counter switch.	2. Replace the Row counter.	
	3. Troubles on the Main P.C.B..		
15. The Row counter never work.	1. The position of the Sensor belt and the Row counter operation lever are not right.	1. Correct the positions of the Sensor belt and the Row counter.	
	2. Broken of the Row counter.	2. Replace the Row counter.	

### 3. NOTES FOR CHECK AND REPAIR

#### 3.1 Caution in Check and Repair

In order to avoid secondary damage, please pay attention to the following points.

- (1) While assembling/disassembling the machine, AC plug must be pulled off the socket.
- (2) Do not disconnect the plug by pulling the cord.
- (3) Tighten screws and nuts securely.
- (4) Do not lose any parts. Sometimes the parts (screw, nut, washer) lost and left inside of the cover cause short circuit.
- (5) The electrical parts are weak at static electricity. Be careful not to touch these electrical parts directly and hold P.C. boards at their edges.
- (6) Please wrap the P.C.B.s with aluminium foil or anti-static electricity bag for the transportation.
- (7) After the completion of assembling, check to ensure that all connectors are properly connected and that the equipment operate normally.

#### 3.2 Two Types of Motor Drive Unit

There are 2 types of motor drive unit namely L (long) type and S (short) type.

L-type..... all round type

S-type..... It can not use with KH-260 for Its short rail.

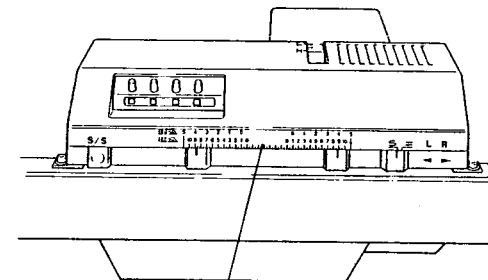

**\*How to distinguish between both types**

(1) Operation range indicator



(2) Difference between L and S types

Ref. No.	Description	Parts code		Difference
		L	S	
A-1	Head frame with shaft	414671001	415149001	Strain relief/cord bush
A-63	Motor head upper cover			Operation range indicator
B-15	Driving belt	414757000	414872000	Length of the belt
B-25	Rail frame with name plate	415061001	415062001	Length
B-47	Belt cover	415007000	415008000	Length
B-49a	Knitting machine setting bar	487435001	487436001	Length Disk for Table clamp.

## 4. CIRCUITRY CONFIGURATION

### 4.1 KE-100 Block Diagram

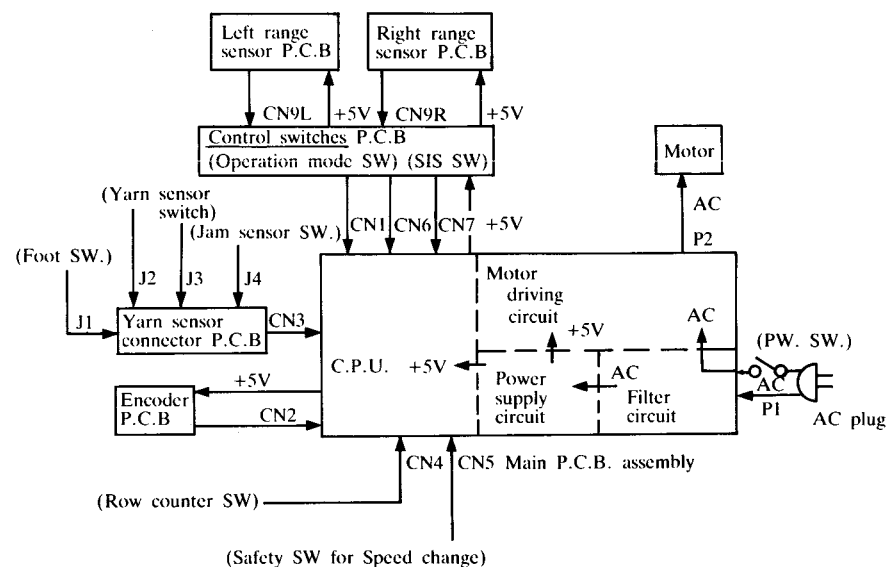

Fig. 1-1

### \*Important parts and their location

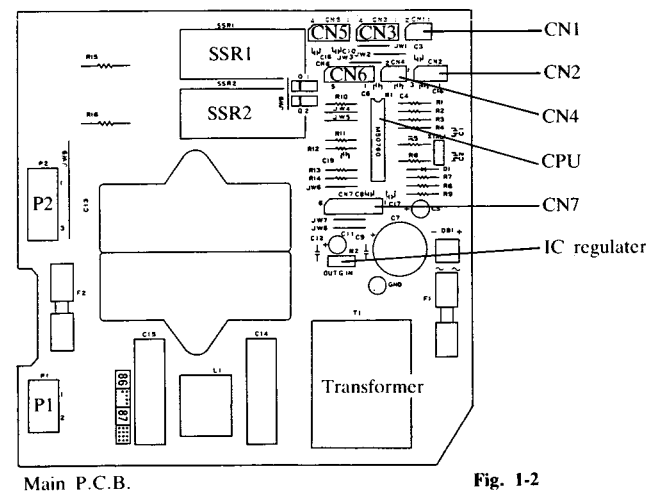
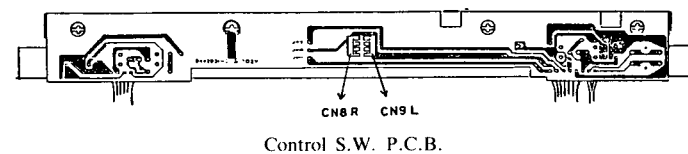

Fig. 1-2

Address	Pins	Connection
CN1	2	Start/Stop SW of the control panel
CN2	3	Encoder P.C.B.
CN3	4	Yarn sensor connector P.C.B.
CN4	2	Row counter SW
CN5	4	Safety SW for speed change
CN6	5	Mode SW and LED of the control panel
CN7	6	left/right range sensor P.C.B. (from the control panel)
P1	2	AC source
P2	3	Motor

#### **4.2 Main P.C. Board**

The Main P.C. Board is composed of the Filter circuit, Power supply circuit, Motor driving circuit and C.P.U. (4 bits-micro computer).

(1) Power supply circuit

The AC power which is input through the AC cord and the Power switch will be filtered by the Filter circuit to cut out the line-noises, and it is supplied to the motor and the transformer. Then the voltage of AC power should be decreased to about AC+9V by the Transformer. This is finally rectified and stabilized into DC+5V, then supplied to the Main P.C.B. and the other P.C.B..

(2) Motor driving circuit

The motor is driven and controled by the SSR (Solid state relay) No. 1 and No. 2. While the shuttle is travelling to the right, the SSR 1 is ON and the SSR 2 is OFF and vice versa.

(3) CPU

This is a 4-bits CMOS micro computer, and worked by +5V DC power. The CPU controls both of the SSRs and the Direction indicators (LED) by judging the signals from the various switches and the sensors according to the program.

#### **4.3 Encorder P.C.B.**

The Encorder P.C.B. sends the signal to the CPU to make the CPU recognize the revolution speed of the Motor. And it is connected with the Main P.C.B. by the connector CN2.

#### **4.4 Yarn Sensor Connector P.C.B.**

There are 4 jacks (Foot switch, Yarn sensor switches and Jam sensor switch) on the P.C.B. and connected with the Main P.C.B. with the connector CN3.

#### **4.5 Control Switches P.C.B.**

This is composed of the Operation mode change switch, S/S (start/stop) switch and the Direction indicator lamps. It is connected with the Main P.C.B. by the connectors CN1 and CN6.

#### **4.6 Left/Right Range Sensor P.C.B.**

These sensor P.C.Bs recognize the turning point of the shuttle. The operation range will be fixed by these 2 P.C.Bs. They are connected with the Main P.C.B. through the control switches P.C.B. by the connectors CN9L, CN9R and CN7.

#### **4.7 Switches**

(1) Yarn sensor switch

This is provided with the Yarn sensor assembly. The Yarn sensor detects the troubles such as Yarn-cut, yarn-run-out and yarn-knot on the yarn tension unit and if some troubles happened, send the signal to the CPU to stop the motor.

(2) Jam sensor switch

When the carriage jams (over load), the coupler release the carriage to keep the machine away from the damage. And the lever turned into vertical position at the reverse side of the coupler comes in contact with the Jam sensor switch to stop the motor.

(3) Row counter switch

Since the Row counter for KE-100 is a subtraction counter, after knitting the number of row previously set (the counter number comes to ZERO), the Row counter switch is turned on so that the signal will be sent to the CPU to stop the motor.

(4) Safety switch for speed changer

The changing of operation speed is done by the gears and not by the changing of the revolution speed of the motor. There is no clutch in the gear box, therefore it is necessary to prevent the gear-crush by stopping the motor in case the user tries to change the operation speed without stopping the motor. The safety switch detects the movement of the speed change lever and if the user tries to change the operation speed without stopping the motor, the safety switch works and sends the signal to the CPU to stop the motor.

## 5. DISASSEMBLING FOR EASY CHECKING

\*Before disassembling, never fail to take away the AC cord plug from the plug socket.

### 5.1 Removing the Motor Head Cover

- (1) Set the speed change knob on H position.
- (2) Loosen the ten screws (Round head with washer 3×8, 10 pcs.) so that the screw head is 1 mm from the cover. (Refer to Fig. 2)

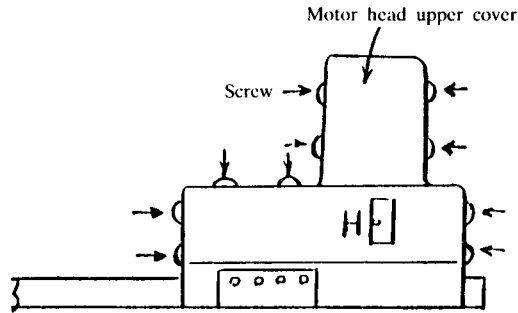

Fig. 2

- (3) Pull the Motor head lower cover under the motor to take it away.
- (4) Pull the cover upward to take it away. (Refer to Fig. 3)

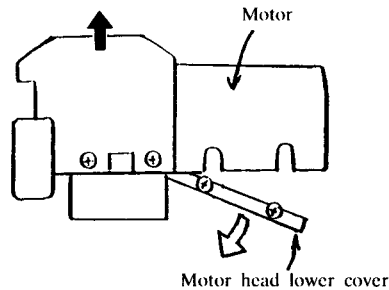

Fig. 3

\*You can check and repair following points after removing the motor head cover.

- A. Row counter
- B. P.C. board
- C. Switches and sensors

### 5.2 Mounting the Motor Head Cover

- (1) Make sure that the connectors are joined and that the Cord clips hold the cord.
- (2) Set the Speed change knob on H position.
- (3) Loosen the ten screws fixing the covers enough.
- (4) Put the power switch in the Head frame securely.
- (5) Put the Motor head upper cover on the Motor and push down it so that all the screws are in the recess of the screw groove. Then tighten the screws. (Refer to Fig. 4).

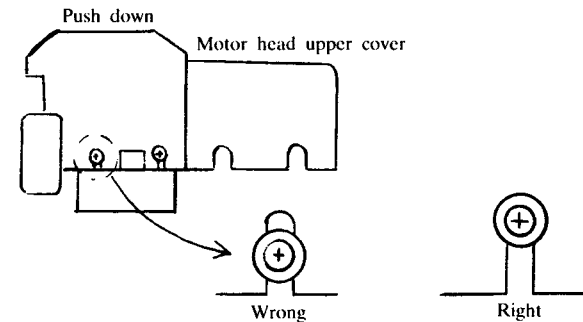

Fig. 4

- (6) Hook the Lower cover on the Head frame and push the lower cover into the Head cover. Then tighten the 4 screws with supporting the under cover. (Refer to Fig. 5)

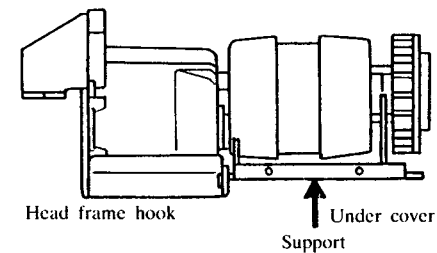

Fig. 5



## 6. REMOVING THE MOTOR HEAD

- (1) Loosen the bolt on the bottom face of the right-side (Motor-side) of the rail. (Refer to Fig. 6)

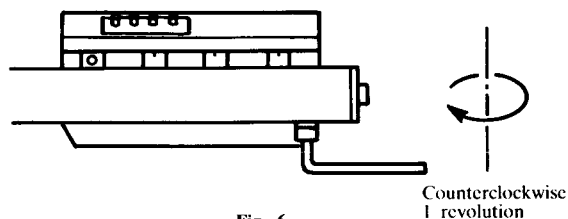

Fig. 6

- (2) Tighten the bolt on the right end of the rail until you feel heavy with the bar wrench (after you turn it about two round). (Refer to Fig. 7)

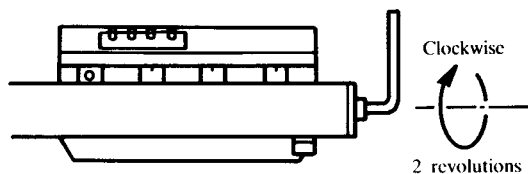

Fig. 7

- (3) Tighten the bolt which you loosen in step (1).

**\*Note:**

By the operation (1)-(3), the pulley is fixed to get easy re-assembling.

- (4) Remove the bolt (5×8) and washer for the Belt cover.
- (5) Pull out the Belt cover to the opposite direction of the Motor head.
- (6) Take the Jam sensor (Motor stop sensor), Yarn sensors and plug of Foot switch out of the Motor head.
- (7) Remove the three bolts (5×8) Fixing the Motor head to the Rail. (Refer to Fig. 9)

**\*Support the Motor head with your hand so that it doesn't fall.**

- (8) While supporting the motor head with your hand, pull it out the rail.

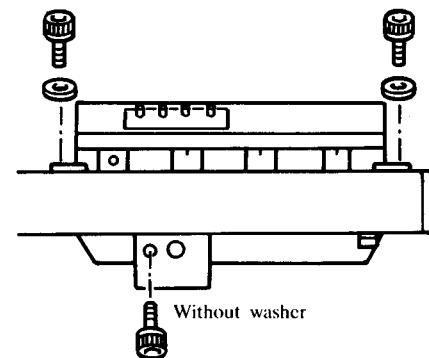

Fig. 9

## 7. DISASSEMBLING THE MOTOR HEAD

### 7.1 Removing the Motor Cover

Refer to 5-1 (on p.7).

### 7.2 Removing the Control Panel

- (1) Unfasten the Control switches P.C.B. cords from the Cord clip and disconnect the connector No. CN1, CN6 and CN7 from Main P.C.B.. (Refer to Fig. 10)

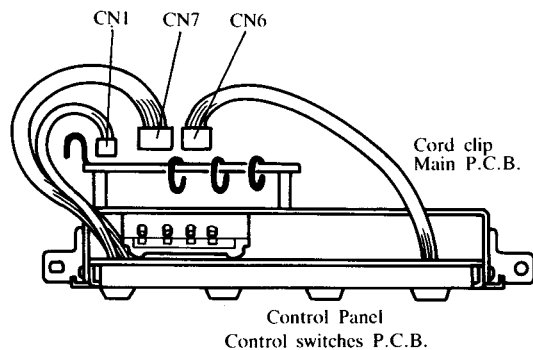

Fig. 10

- (2) Remove the 2 screws (+- screw 3×8) of the Control panel. (A in Fig. 11)

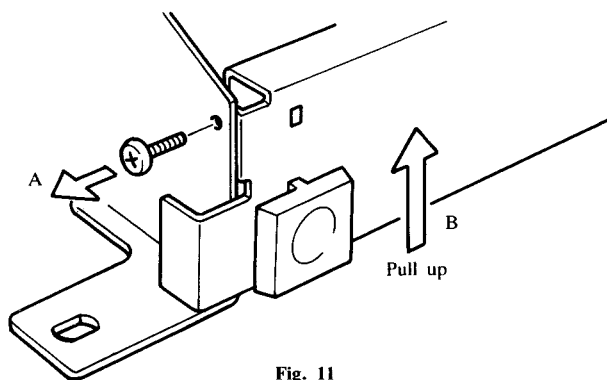

Fig. 11

- (3) Pull up the Control panel to remove it.
- (4) Disconnect the Right and Left range sensor connector from the Control switch P.C.B.. (Refer to Fig. 12)

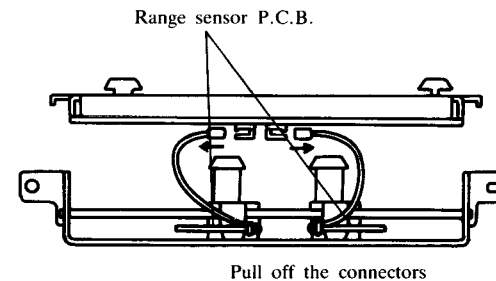

Fig. 12

### 7.3 Removing the Gear Box

- (1) Disconnect the Motor (P2, 3 pins) and Encorder P.C.B. (CN2, 3 pins) connectors from the Main P.C.B.. (Refer to Fig. 13)

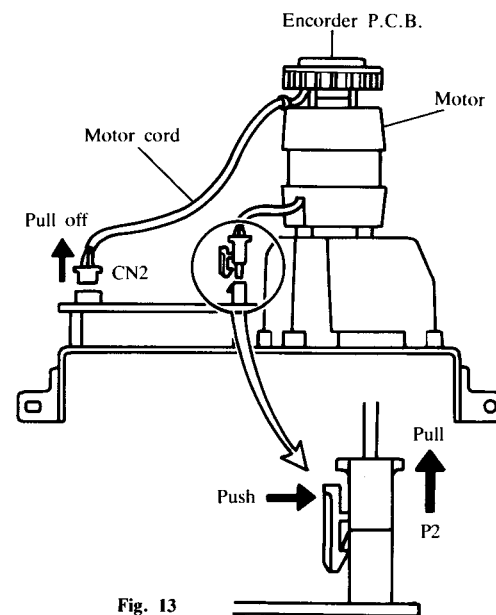
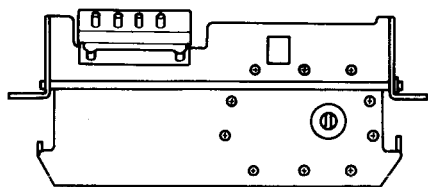

Fig. 13

- (2) Remove the ten screws (Round head 4×16) fixing the gear box on the head frame. (Refer to Fig. 14)



Tapping screw (Black)

Fig. 14

- (3) Set the speed change knob on H and then remove the gear box as shown in Fig. 15.

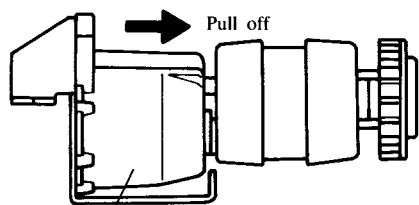

Gear box

Fig. 15

#### 7.4 Removing the Gears

- (1) Lift the Speed change knob up to separate it from the gear and pull the knob to the direction of the arrow indicated in Fig. 16 to remove the knob. (Speed change knob spring is also removed.)

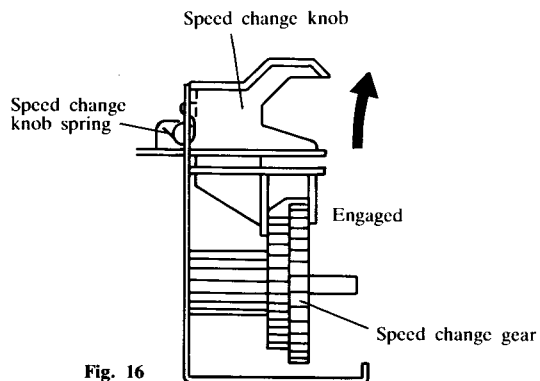

Fig. 16

- (2) Pull out both speed change gear and Driving shaft (with gear) simultaneously. The Ball bearing A is remained in the Head frame and the Ball bearing B will be in the gear box or on the Driving shaft. (Refer to Fig. 17)

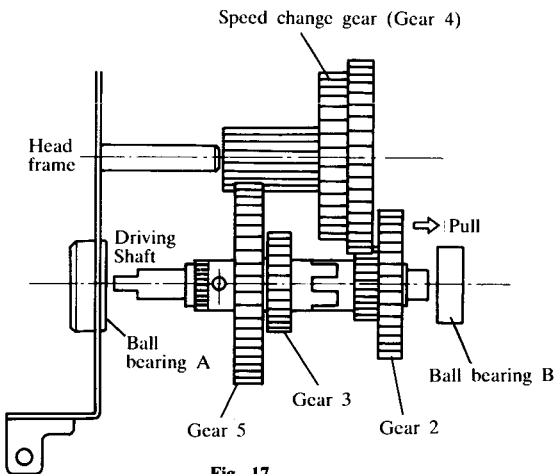

Fig. 17

#### 7.5 Disassembling the Gears

- (1) Remove the Snap ring (E9), then the Gear 2 and the Gear 3 will come off the Driving shaft. (Refer to Fig. 18)

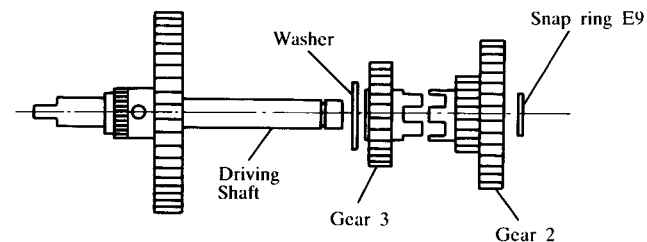

Fig. 18

- (2) Take out the Spring pin (AW4) by using the stick (diameter is about 3.0–3.8 m/m) and the hammer. The Gear 5 will come off the Driving shaft. (Refer to Fig. 19)

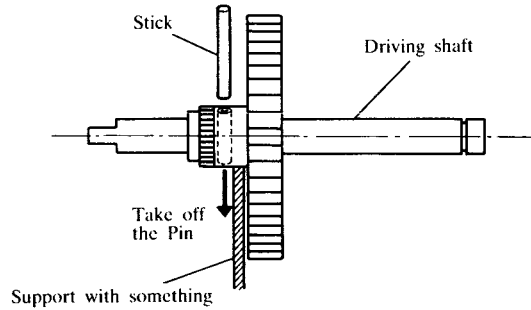

Fig. 19

### 7.6 Removing the Motor Assembly

- (1) Remove the three screws which are inside of the Gear box. The gear box comes off. (Refer to Fig. 20)

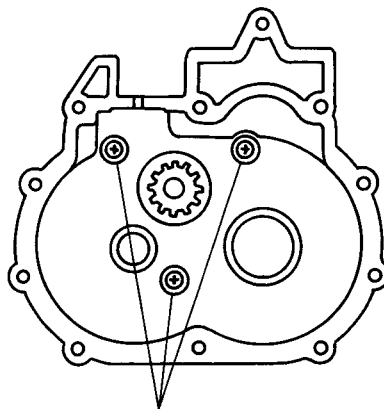

Fig. 20

- (2) Take out the Spring pin (AW 2.5) by using the stick ( $\phi = 2.0$  m/m) and the hammer. The Gear 1 will come off. (Refer to A in Fig. 21)
- (3) Take out the Spring pin for the Fan in the same way as the step (2). (Refer to B in Fig. 21)

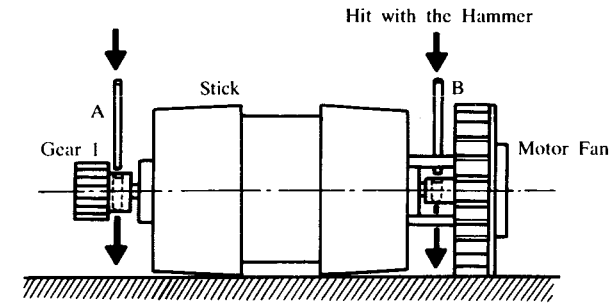

Fig. 21

- (4) Unfasten the encorder code from the code clip on the motor and remove the three screws so as to remove the Encorder P.C.B..  
**\*Please do not disassemble the motor.**

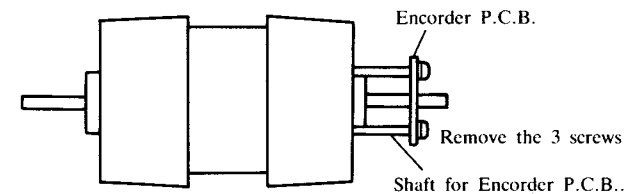

Fig. 22

## 7.7 Removing the Row Counter

- (1) Disconnect the Row counter connector CN4 from the Main P.C.B. (Refer to A in Fig. 23)

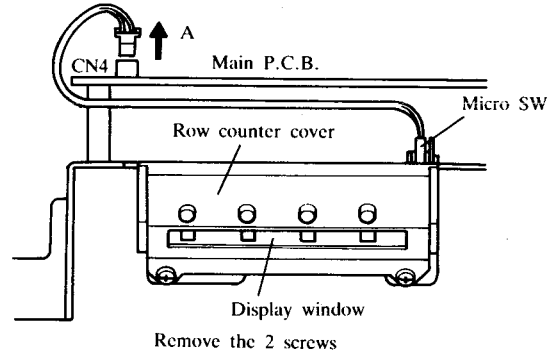

Fig. 23

- (2) Remove the two screws (Round head 3×6) the row counter will come off together with the Display window.

### \*Note

While taking out the Row counter, do not push Strongly on the both side face of it to avoid it broken down. (Refer to Fig. 24)

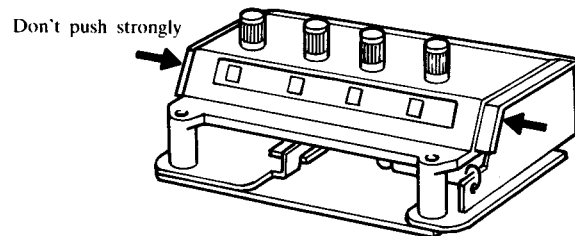

Fig. 24

## 7.8 Removing the Operation Range Knob

- (1) Remove the snap ring E6 on the right side of Head frame. (Refer to A in Fig. 25)

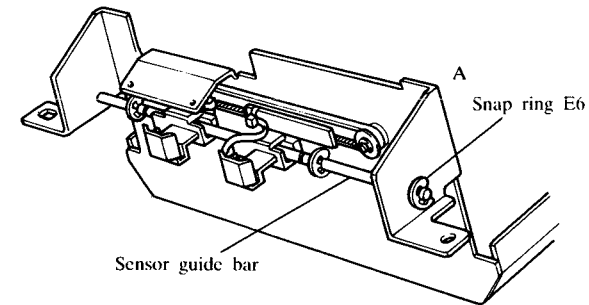

Fig. 25

- (2) Move the Sensor guide bar to the left so that the right end of the sensor guide bar comes off the frame. Then pull the Sensor guide bar out. (Refer to Fig. 26)

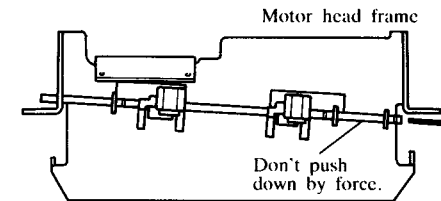

Fig. 26

- (3) Remove the Snap ring E6 on the left side of the bar and take out the Operation range knob. (Refer to Fig. 27)

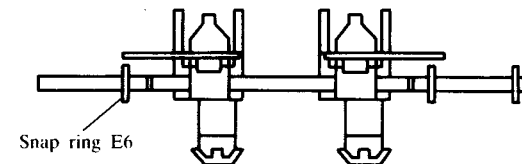

Fig. 27

### 7.9 Removing the Sensor Belt.

The Sensor belt is stretched by the spring. Push the Shaft of Idle pulley which is on the reverse side against the spring, then the Sensor belt will become loose, remove the sensor belt from the idle pulley. (Refer to Fig. 28)

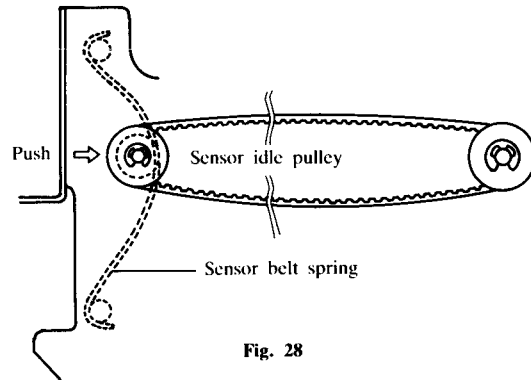

Fig. 28

### 7.10 Removing the Magnet for the sensor.

While taking the Sensor belt off the Sensor magnet holder, make the Sensor magnet holder upside-down. The magnet will come out. (Refer to Fig. 29)

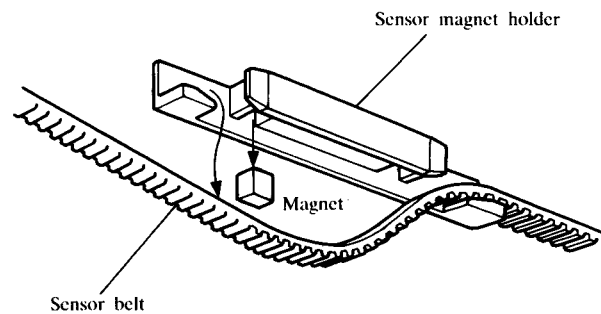

Fig. 29

### 7.11 Removing the Main P.C.B.

- (1) Disconnect all connectors on the Main P.C.B..
- (2) Remove the four screws (Round head 3×8), the Main P.C.B. will come off. (Refer to Fig. 30)

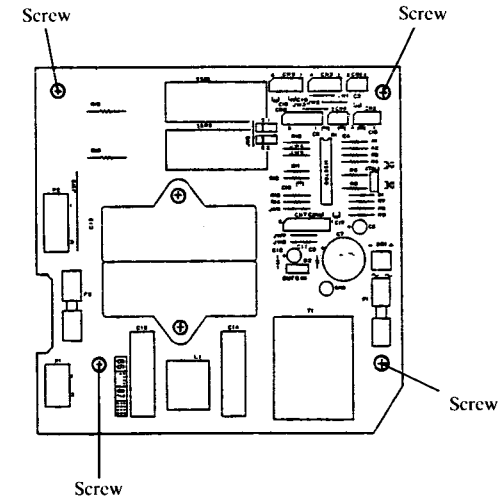

Fig. 30

### 7.12 Removing the Yarn Sensor Connector P.C.B.

Remove the four nuts and pull the P.C.B. out. (Refer to Fig. 31)

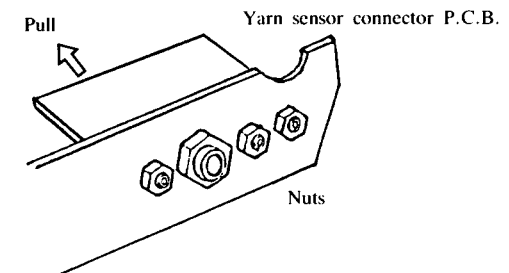

Fig. 31

### 7.13 Removing the Row counter tripper

This work can not be done if the Main P.C.B. has been fixed.

- (1) Remove the Row counter operating spring. (Refer to A in Fig. 32)
- (2) Remove the Snap ring E3 for the Tripper then pull the Row counter tripper. (Refer to B in Fig. 32)

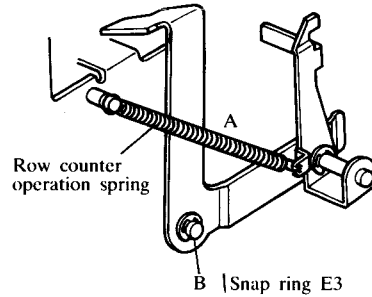

Fig. 32

### 7.14 Removing the Sensor Idle Pulley

- (1) Remove the Sensor belt tension spring from the Shaft for sensor idle pulley and the Head frame base. (Refer to Fig. 33)
- (2) Pull off the Shaft of sensor idle pulley, then remove the Snap ring E3. The Idle pulley will come off.

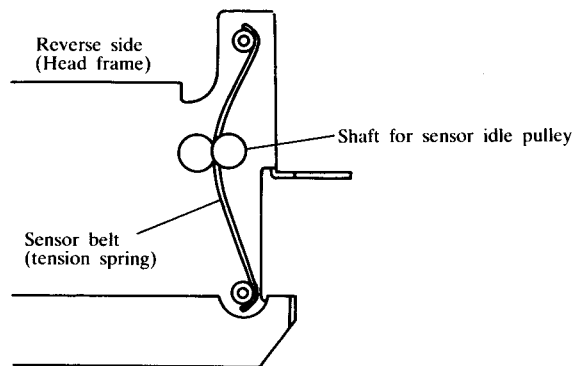

Fig. 33

### 7.15 Removing the Sensor Driving Pulley

- (1) Remove the Snap ring E3 and the washer fixing the Sensor driving pulley. (Refer to Fig. 34)

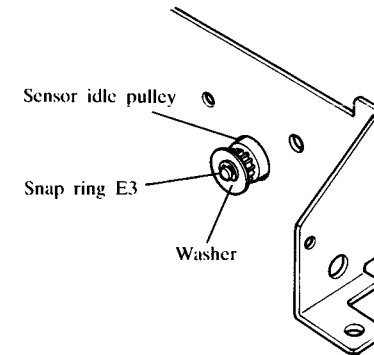

Fig. 34

- (2) Remove the Snap ring E3 for the Gear 6 and remove the Gear 6 which are inside of the Head frame. (Refer to A in Fig. 35)
- (3) Remove the two screws (3×5), then the Bracket and the Sensor driving pulley (gear) will come off. (Refer to B in Fig. 35)

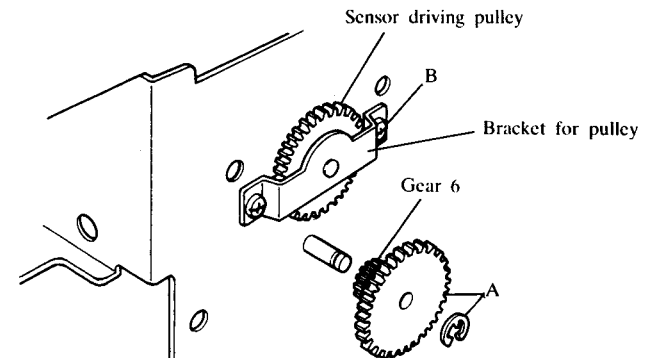

Fig. 35

## 8. ASSEMBLING THE MOTOR HEAD

### Note:

In case of putting Spring pin (Sensor magnet holder Stopper)  
There are two types of the Motor Drive Unit namely the S-type (only for 4.5 m/m needle pitch machine) and the L-type (all round type Since the motor head frame is a common part for both types, if you need to replace it, make sure that the Spring pins for the sensor Magnet holder stopper are set on the correct position. The inside holes are for S-type and the outside holes are for the L-type. (Refer to Fig. 36-1).

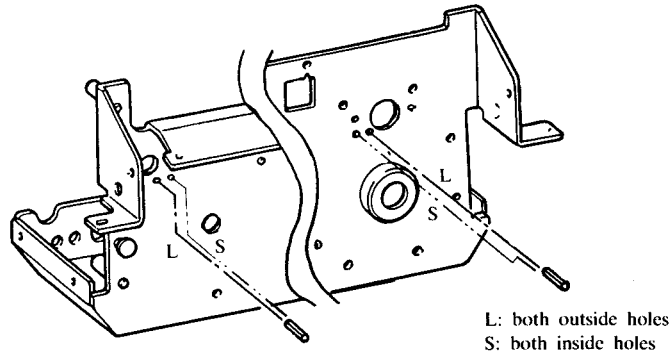

Fig. 36-1

To put the pin, if you use the N.S.P. operation lever (408098001, this is the part for the punch card knitting machine), it can be more easily. Set the N.S.P. operation lever on the pin and hit with the hammer lightly until the pin comes out about 0-0.5 m/m of reverse side. (Refer to Fig. 36-2)

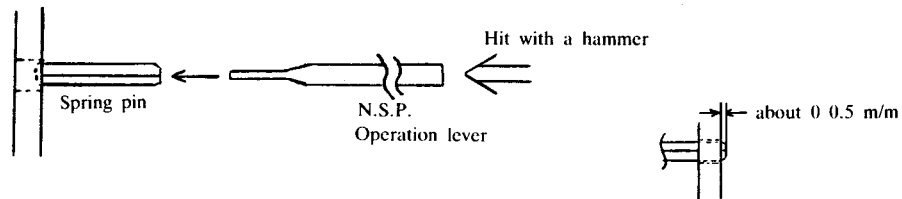

Fig. 36-2

### 8.1 Mounting the Sensor Driving Pulley (Gear)

- (1) Mount the Sensor driving pulley and the Bracket to the Frame and fix them by the two screws (3×5). (Refer to B in Fig. 36-3)

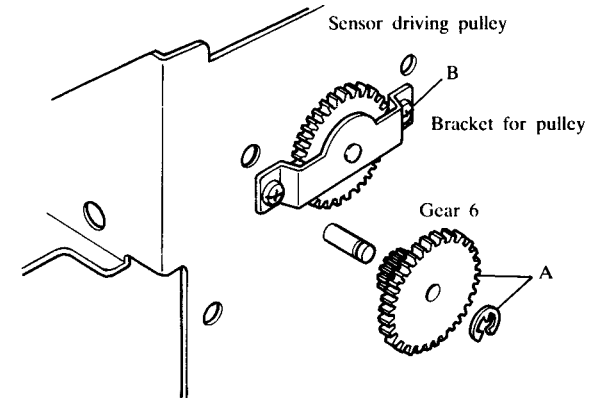

Fig. 36-3

- (2) Put the Washer and the snap ring E3 on the shaft for the pulley from the front side. (Refer to Fig. 37)

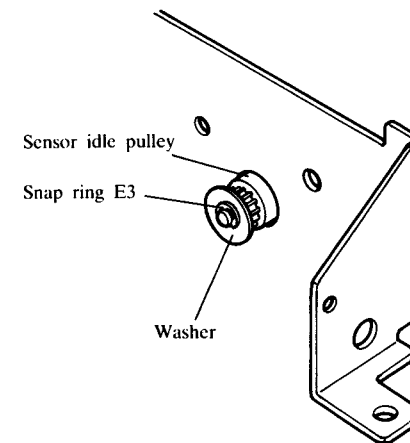

Fig. 37



- (3) Please ensure that the Ball bearing for the driving shaft is in the right place in the Head frame, then mount the Gear 6 and put the Snap ring E3 on the shaft. (Refer to A in Fig. 36-3)

**Note:**

If you have replaced the gear and/or pulley, put some grease on the shaft.

- (4) Mount the Sensor idel pulley to the shaft and put the Snap ring E3. Then insert it into the fixed place from the front side of the frame and hook the Sensor belt tension spring to the shaft from the inside. (Refer to Fig. 38)

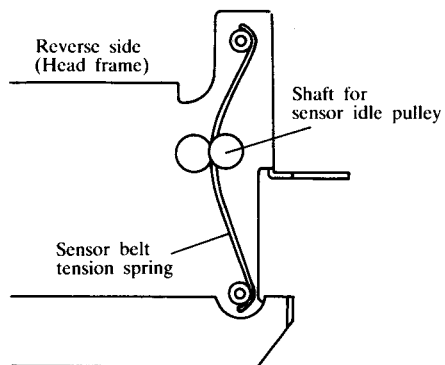

Fig. 38

**8.2 Mounting the Row Counter Tripper**

- (1) Mount the Row counter tripper to the shaft and put the Snap ring E3. (Refer to Fig. 39)
- (2) Hook the Row counter operation spring to the pin on the frame and the Row counter operation lever. (Refer to Fig. 39)

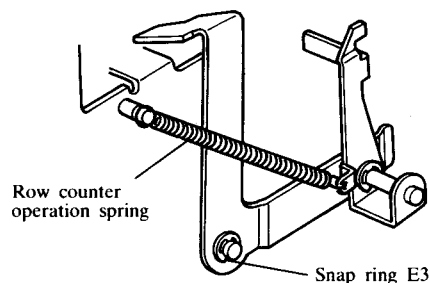

Fig. 39

**8.3 Mounting the Yarn Sensor Connector P.C.B.**

Insert the sockets into the holes on the frame, then fasten them by the nuts (Refer to Fig. 40)

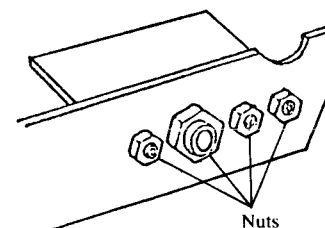

Fig. 40

**8.4 Mounting the Magnet for Sensor**

Put the Magnet in the right box of the Magnet holder. Make sure that the dot-marked face of the Magnet should be against the Head frame. (Refer to Fig. 41)

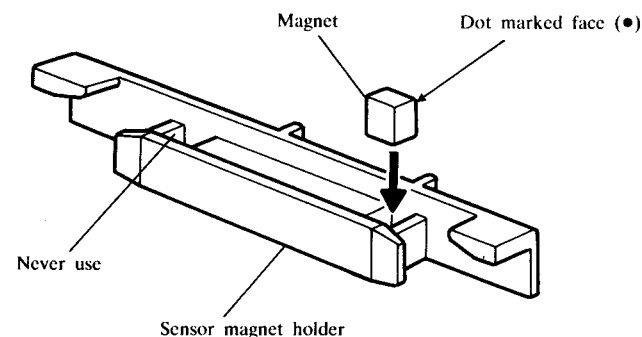

Fig. 41

### 8.5 Mounting the Sensor Magnet Holder and the Sensor Belt to the Head Frame

Sensor belt to the Head frame

- (1) While being the notches of the Belt inside, put the Magnet holder on the Belt. (Refer to Fig. 42)

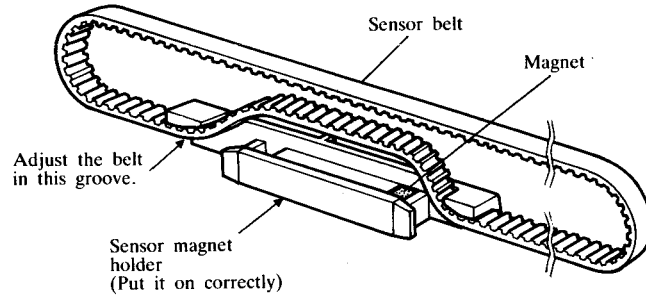

Fig. 42

- (2) Push the sensor belt spring to the direction of the sensor driving pulley and set the belt to the driving pulley and the idle pulley.

**\*Note:**

The sensor belt should be under the Sensor belt presser and the Row counter operation lever should engage the notch of the belt. (Refer to Fig. 43)

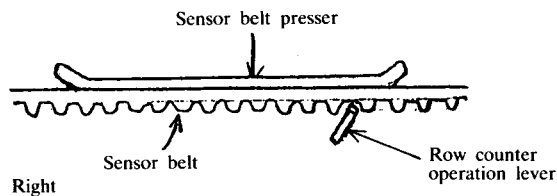

Fig. 43-1

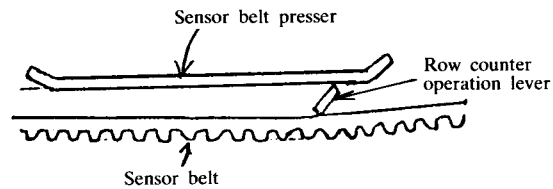

Fig. 43-2

### 8.6 Mounting the Right/Left Range Sensor P.C.B. for the Operation Range Knob

If you replace the right/left range sensor P.C.B., fix the P.C.B. on the knob with the rubber-base or silicon-base glue. (Refer to Fig. 44)

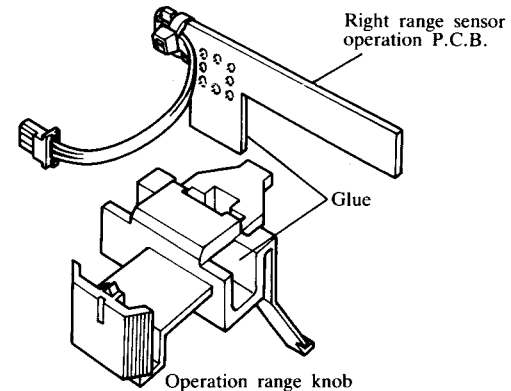

Fig. 44

### 8.7 Mounting the Operation Range Knob

- (1) Put the right side operation range knob at first, then put the left side operation range knob on the sensor guide bar, and snap the snap rings E6 on the grooves A and C on the shaft. (Refer to Fig. 45-1)

**Note:**

The grooves B are for the short-type Motor Drivt unit.

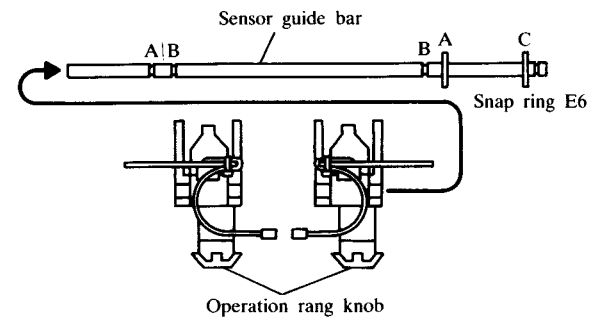

Fig. 45-1

- (2) Pass the left end of the Sensor guide bar through the hole for it on the left side of the frame far enough, then return to the right to pass the right end of the bar through the hole for it. Then put the snap ring E6 on to the bar. (Refer to Fig. 45-2)

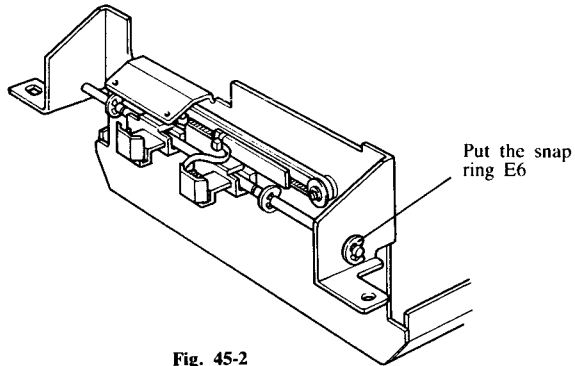

Fig. 45-2

**\*Note:**

- (1) The top (A) of the knob should be located between the belt. (Refer to Fig. 46)
- (2) Insert the left end of the sensor guide bar into the left-side-hole of the head frame, then the right end into the right-side-hole. And slide the bar to the right as much as you can.
- (3) Snap the snap ring E6 on the right end groove of the sensor guide bar to fix it.

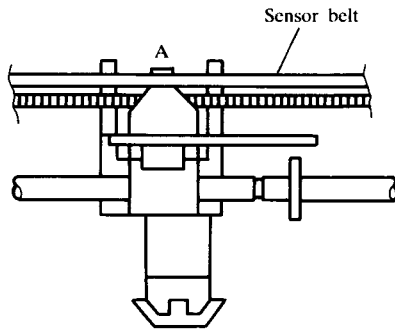

Fig. 46

### 8.8 Mounting the Row Counter Assembly

- (1) Set the Row counter assembly and the Display window, then insert the screws into the holes on both side of the Row counter assembly.
- (2) By moving the Sensor belt, place the Row counter tripper to the right end. Adjust the position of the row counter and fix it with screws. (Refer to Fig. 47)

**\*Do not move the row counter tripper by force.**

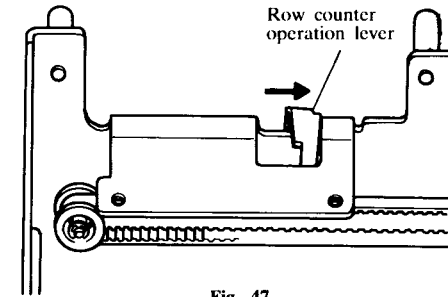

Fig. 47

### 8.9 Mounting the Motor Assembly

#### 8.9.1 Mounting the encorder P.C.B.

Set the Encorder P.C.B. to the Motor as illustrated in the Fig. 48 and fix it by three screws (3×6).

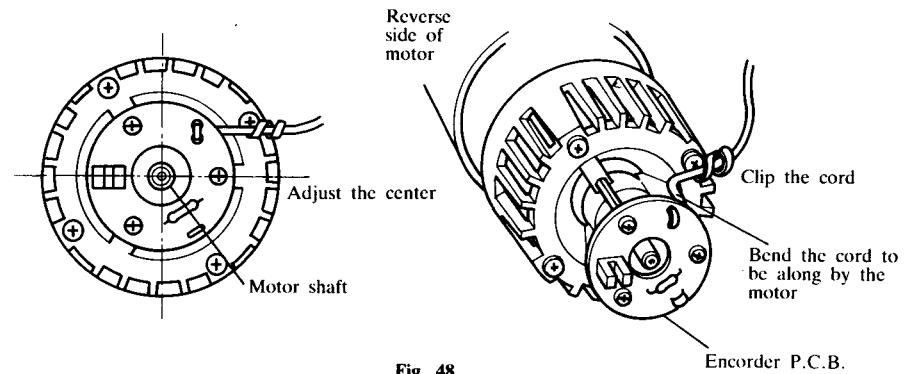
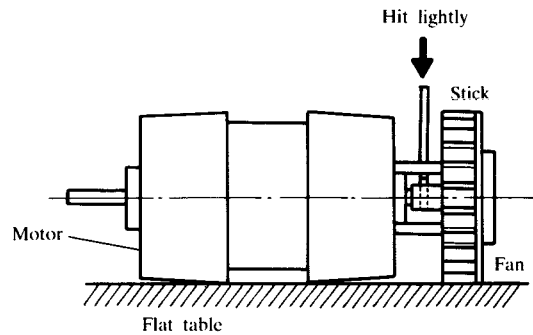

Fig. 48

### 8.9.2 Mounting the motor fan and the Gear

- (1) Adjust the hole for the Spring pin ( $\phi 2.5 \times 16$ ) of the fan and of the shaft, and push the spring pin into the hole. Then hit the pin lightly by using the stick and the hammer. (Refer to Fig. 49)



\*Put into the pin so that both end of the pin come to equal length. Pin. 49

Fig. 49

- (2) Mount the gear 1 to the shaft in the same way as above (1) (Refer to Fig. 50)

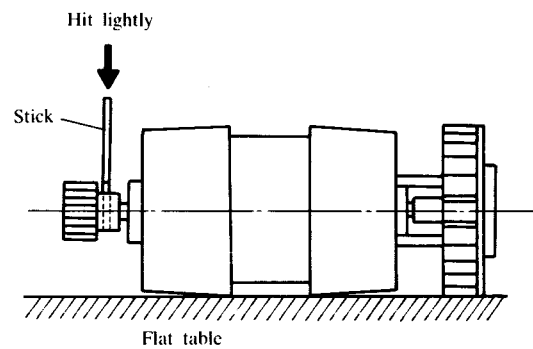

Fig. 50

#### Note:

- (1) Take care not to break the gear and the fan.
- (2) If the spring pin could not be inserted into the hole, never hit it strongly. Fit the hole carefully and try again.

### 8.10 Mounting the Motor and the Gear Box

- (1) Set the cord of the motor and the Gear box as illustrated in Fig. 51.
- (2) Mount the gear box to the motor with the three screws ( $4 \times 25$ ) (Refer to Fig. 52)

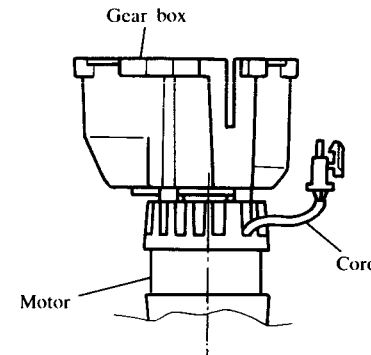

Fig. 51

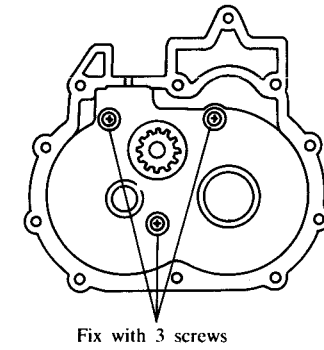

Fig. 52

### 8.11 Mounting the Gear

- (1) Put the Gear 5 on the driving shaft and fix them with the spring pin. (AW4) (Refer to Fig. 53)

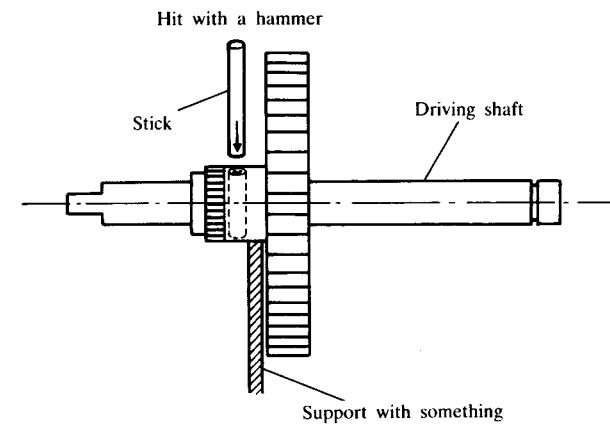

Fig. 53

(2) Put the washer ( $\phi 12$ ), Gear 3 and the Gear 2 on the driving shaft. (Refer to Fig. 54).

\*When you install the gears, put some grease which is adhered to the inside wall of the Gear box to the washer and Gears.

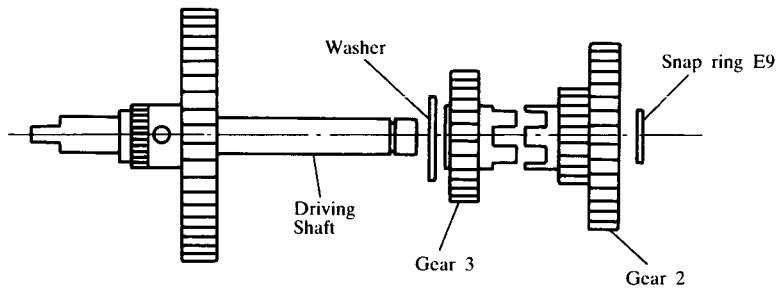

Fig. 54

(3) Put some grease on the shaft for speed change gear. With gearing the gear 4 with the gear 5 and the gear 2, install them to the shaft and the Ball bearing A simultaneously. (Refer to Fig. 55)

(4) Put the Ball bearing B to the end of the driving shaft.

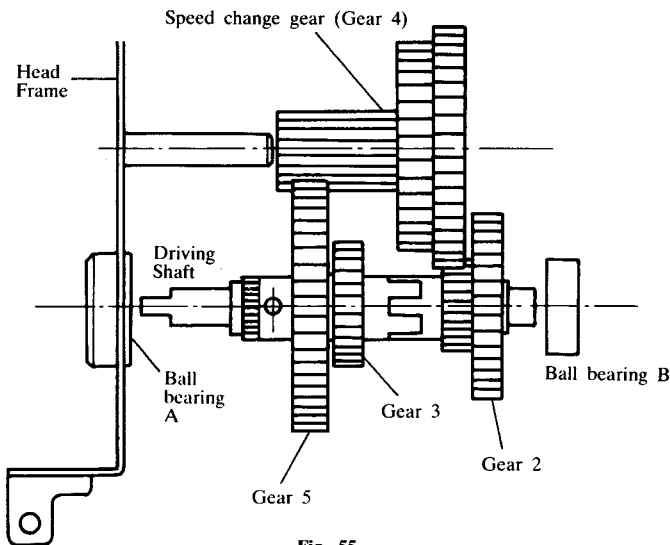

Fig. 55

## 8.12 Mounting the Speed Change Knob

Place the speed change knob on the speed change gear (Gear 4), then move it to the head frame side. (Refer to Fig. 56)

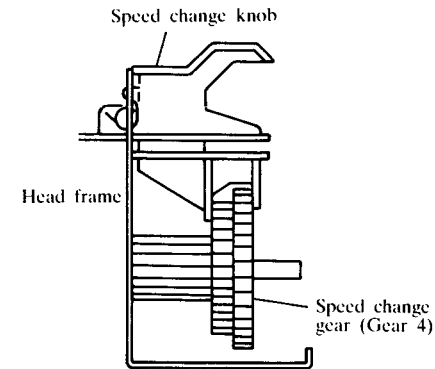

Fig. 56

## 8.13 Mounting the Gear Box and the Motor Complete

(1) Set the speed change knob in the guide groove of the gear cover and put the gear cover on the head frame. (Refer to Fig. 57)

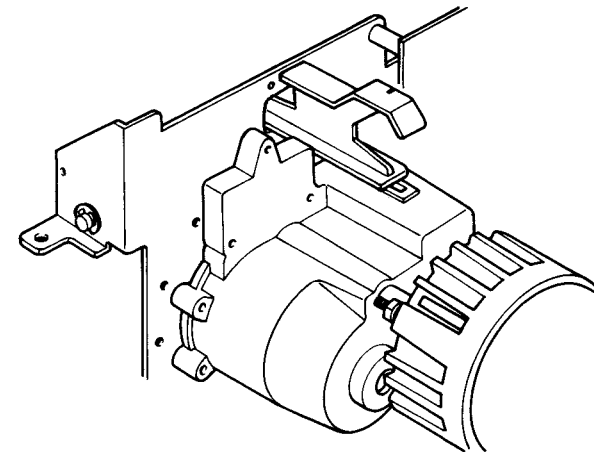

Fig. 57

- (2) Fix the gear cover by the ten tapping screws (2×14).

**\*Note:**

At first, fasten the two screws on the A position temporarily, then the other screws. After all screws are fastened temporarily, tighten them from A to the others. (Refer to Fig. 58)

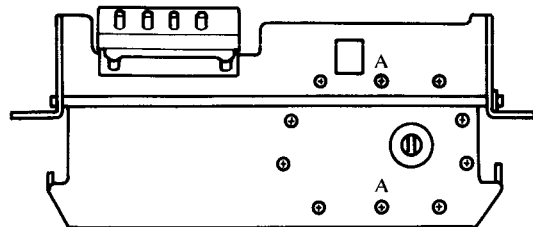

Fig. 58

### 8.14 Mounting the Speed Change Knob Spring

Set the Speed change knob at the rear end and hook the part B of the spring on the hole of the frame. Then insert the part A into the hole of the knob. (Refer to Fig. 59)

**\*Note:**

If you would replace or mount again the Micro switch, please set it like "u", not "n". (Refer to Fig. 60)

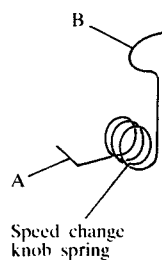

Fig. 59

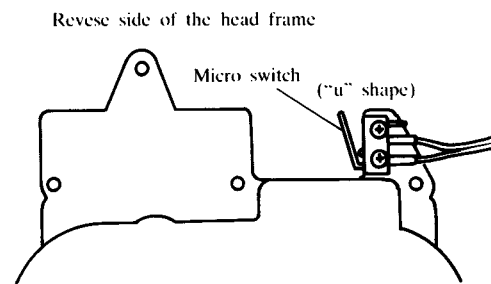

Fig. 60

### 8.15 Assembling the Control Panel

- (1) Put the S/S switch key and the Operation mode selector knob on the control panel. (Refer to Fig. 61)

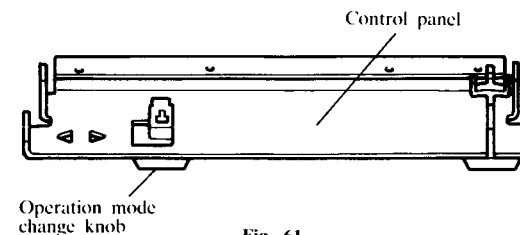

Fig. 61

- (2) Put the control SW P.C.B. assembly to the control panel by adjusting the two direction indicator lamps and the lever of mode selector switch to the holes on the panel and knob. (Refer to Fig. 62)

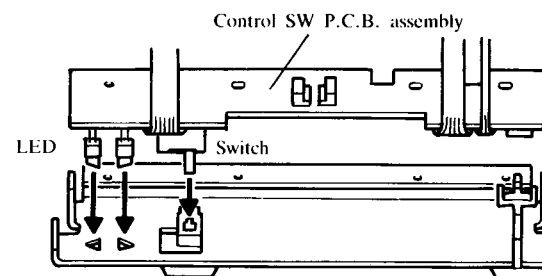

Fig. 62

- (3) Fix them with the four screws (3×8), at the same time, put the cord clip. (Refer to Fig. 63)

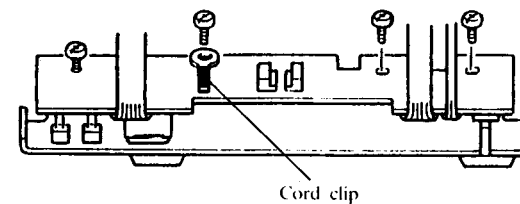

Fig. 63

## 8.16 Mounting the Control Panel

- (1) Place the S/S switch on the left side and connect the connectors for the Left/Right range sensors with the plugs on the Control SW P.C.B. respectively. (Refer to Fig. 64)

**\*Note:**

You have to connect these connectors firmly otherwise the Shuttle would not turn at the turning position.

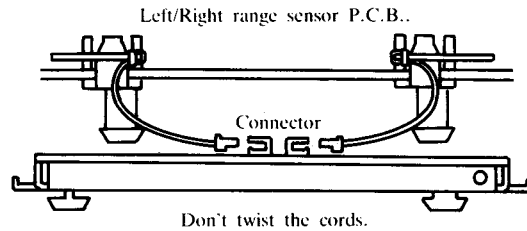

Fig. 64

- (2) Another end of each cord connected with the Control S.W. P.C.B. should be inside of the Head frame and the cords should be along by the Row counter. (Refer to Fig. 65)

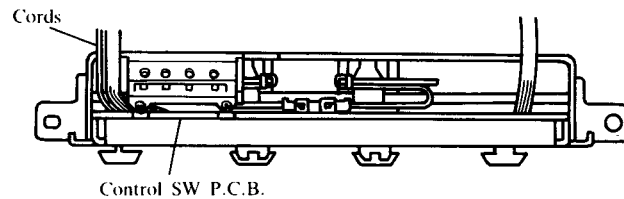

Fig. 65

- (3) Fix the control panel with the two screws. (3×8)
- (4) Bend cord clip to clip the cord on the right side. (Refer to Fig. 66)

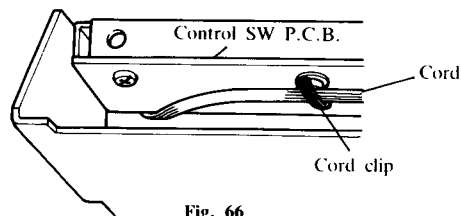

Fig. 66

## 8.17 Mounting the Main P.C.B.

- (1) Mount the Main P.C.B. to the Head frame with four screws.
- (2) Connect each connector with the plugs on the Main P.C.B.. (Refer to Fig. 68)

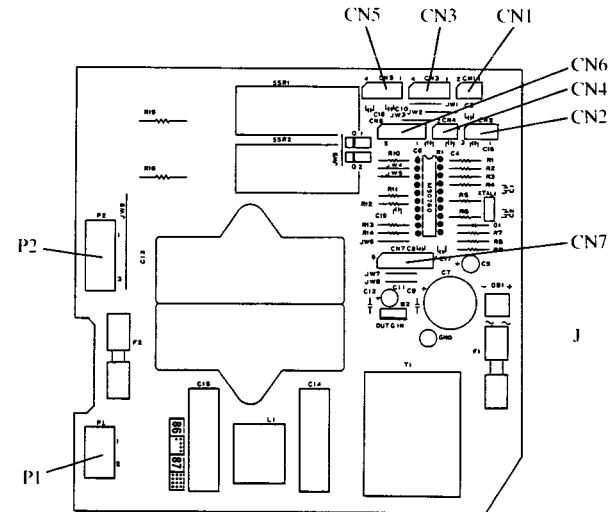

Fig. 68

## 9. REMOVING THE AC POWER CORD

**\*Note:**

- (1) Never connect the connector CN1 as CN4 and AN3 as CN5 nor vice versa because they are very similar connectors to each other.
- (2) Connect each connector with the right plug firmly.

Address	Pins	Connection
CN1	2	Start/Stop SW of the control panel
CN2	3	Encoder P.C.B.
CN3	4	Yarn sensor connector P.C.B.
CN4	2	Row counter SW
CN5	4	Safety SW for speed change
CN6	5	Mode SW and LED of the control panel
CN7	6	left/right range sensor P.C.B. (from the control panel)
P1	2	AC source
P2	3	Motor

- (3) Bundle the cords and clip them with the cord crip on the Main P.C.B..

**\*Note:**

- (1) Make sure that the cord for Encoder P.C.B. never touch the Fan.
- (2) by moving the operation range knob to the right and left, check if the right and left operation range sensor cords move freely. (Never entangle each other.)

### 8.18 Mounting the Motor Head Cover

Refer to the item 5.2 on page 7.

### 9.1 Removing the AC Power Cord

#### 9.1.1. Mold type

Disconnect the connector P1 from the main P.C.B. and take out the Power SW and the strain relief of AC power cord. (See Fig. 69)

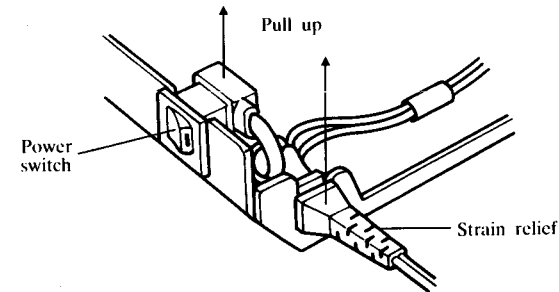

Fig. 69

#### 9.1.2 Cord-bush type

- (1) Remove the earth terminal which is on the bottom of the Head frame by removing the screw and washer. (See Fig. 70-1)

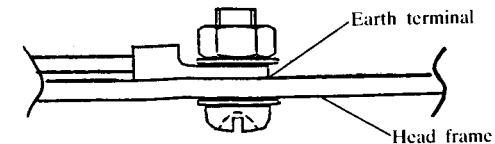

Fig. 70-1

- (2) Disconnect the connector P1 from the Main P.C.B. and take out the Power SW.
- (3) By using the pliers, pull the cord-bush out. (See Fig. 70-2)

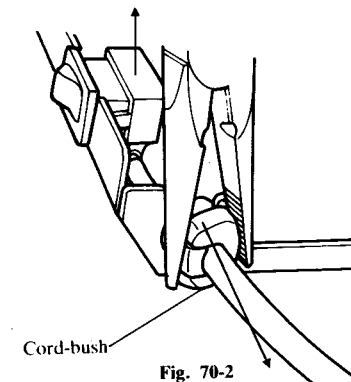

Fig. 70-2



## 10. REMOVING THE SHUTTLE ASSEMBLY

### 9.2 Mounting the AC Power Cord

#### 9.2.1 Mold type (See Fig. 71)

Connect the connector P1 with the Main P.C.B., push in the Power SW and the strain relief.

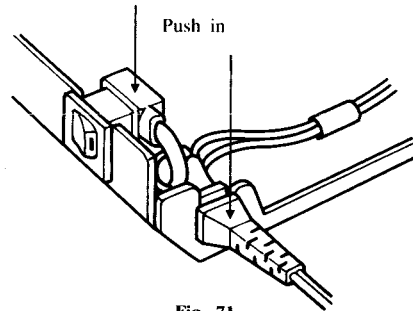

Fig. 71

#### 9.2.2 Cord-bush type (See Fig. 72-1)

(1) Set the bush on the AC power cord and while holding the bush with the pliers, put it on the Head frame.

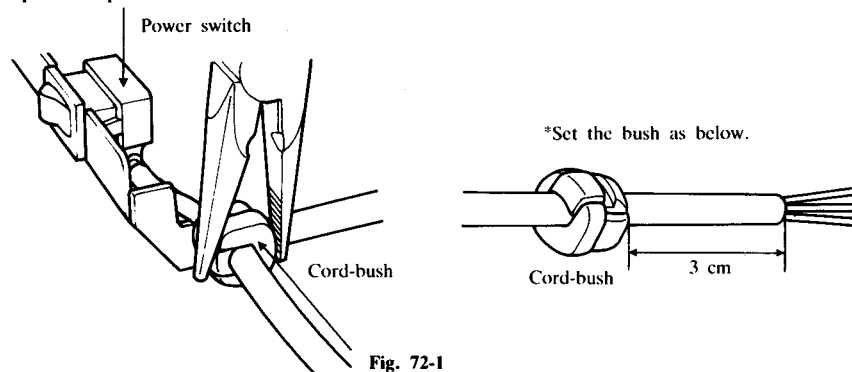

Fig. 72-1

(2) Connect the connector P1 with the main P.C.B. and push in the Power switch.

(3) Fix the Earth terminal to the Head frame. (Refer to Fig. 72-2)

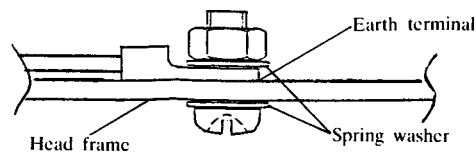

Fig. 72-2

To remove the Shuttle assembly, the motor head should be removed in advance.

- (1) Remove the bolt (5×8) and washer which is on the bottom side of the rail at the right end. (Refer to Fig. 73)
- (2) Remove the bolt (5×25), Washer and the Right end cover for the rail. (Refer to Fig. 73)

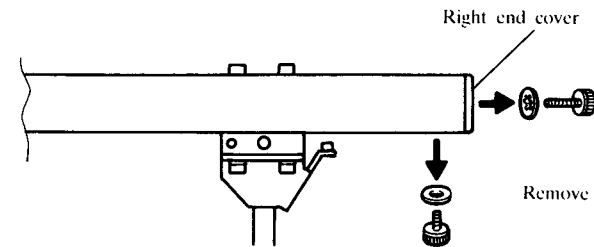

Fig. 73

- (3) Pull the Left end cover so that the idle pulley will come out. (Refer to Fig. 74)

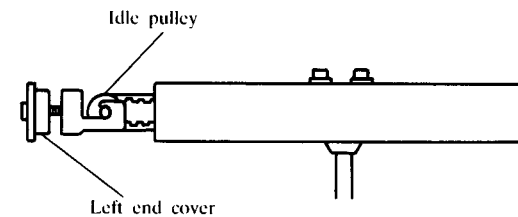

Fig. 74

## 11. HOW TO REPLACE THE DRIVING BELT

- (4) Loosen the bolt for left end cover and remove the idle pulley from the driving belt. (Refer to Fig. 75)

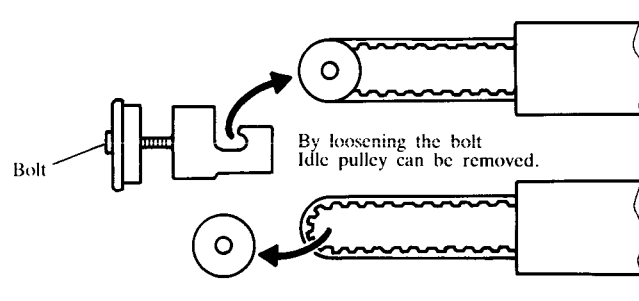

Fig. 75

- (5) Pull the holder for the driving pulley out. Then the shuttle and the driving belt will come out. (Refer to Fig. 76)

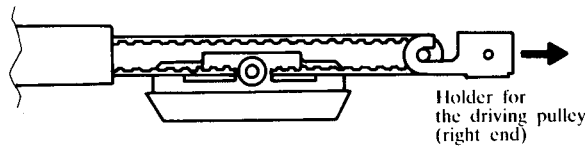

Fig. 76

### 11.1 Removing the Driving Belt

- (1) Take out the driving belt. (Refer to item 10)
- (2) Remove the bolts (5×30) and washers for the belt clamp, then pull out the Driving belt. (Refer to Fig. 77)

### 11.2 Mounting the Driving Belt

- (1) Fit the racks of the belt to the groove of the clamp, then fix them with the bolts and the washers. (Refer to Fig. 77)

**\*Note:**

- (1) The belt should not protrude beyond the clamp.
- (2) Do not twist the belt.

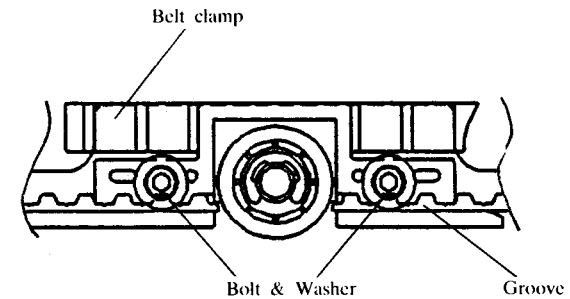

Fig. 77

## 12. DISASSEMBLING AND ASSEMBLING THE SHUTTLE BASE

### 12.1 Disassembling the Shuttle Base (See Fig. 79-1)

- (1) Loosen the two screws (3×8) for the Shuttle cover and remove the cover.
- (2) Remove the screw (3×8) and put off the shuttle spring.
- (3) Remove the three Snap rings E8 and the six washers, then the Rollers will come off.

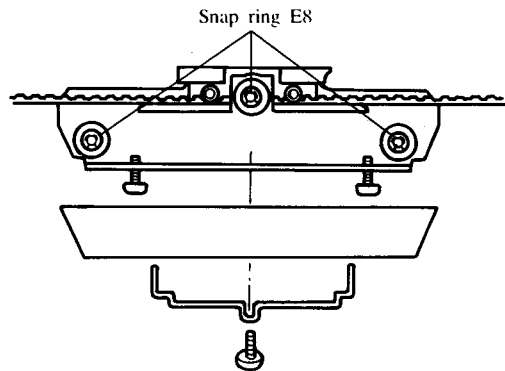

Fig. 79-1

### 12.2 Assembling Shuttle Base (See Fig. 79-2)

- (1) Put the washer, the roller and another washer on the each 3 shafts for roller, then put the Snap ring E8 to the shaft.
- (2) Set the Shuttle spring by the screw.
- (3) Set the Shuttle cover on the base and fasten it with the two screws.

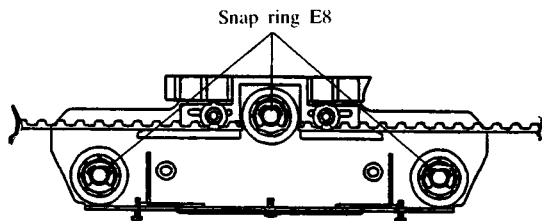

Fig. 79-2

## 13. MOUNTING THE SHUTTLE BASE AND THE MOTOR HEAD

### 13.1 Mounting the Shuttle Base to the Rail

- (1) Put the Driving belt into the Rail and set the Shuttle base to the Rail. (The shuttle cover is facing towards you) (Refer to Fig. 80)

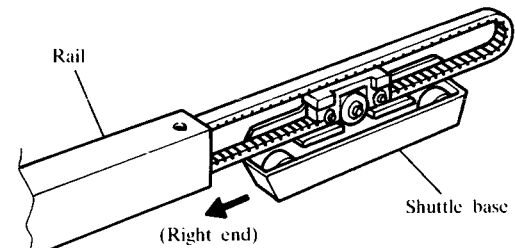

Fig. 80

- (2) Set the Driving pulley to the Driving belt, then set the pulley in the holder. (Refer to Fig. 81)

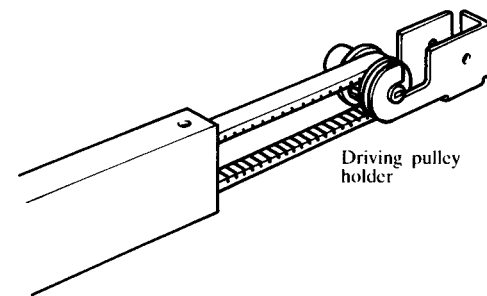
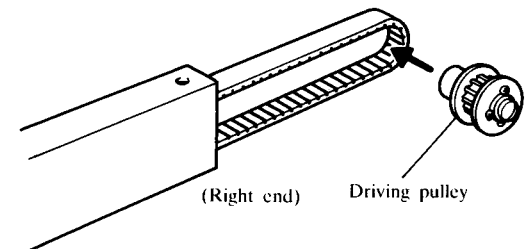

Fig. 81

- (3) Pull the Driving belt from another end. (The Driving pulley and the Holder get into the rail.) Set the Idle pulley and the holder. (Refer to Fig. 82)

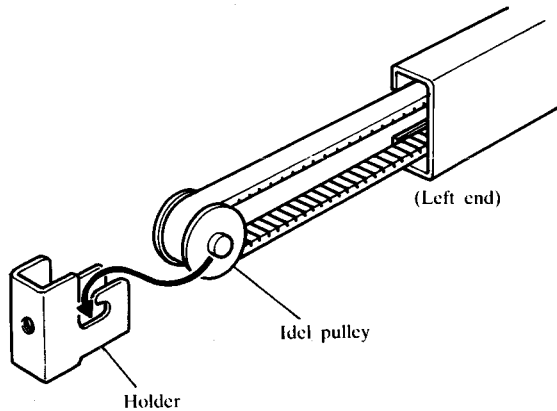

Fig. 82

- (4) Place the Driving pulley and the Holder which are inside of the rail at the right end and fix with the bolt (5×8) with the washer. (Refer to Fig. 83)

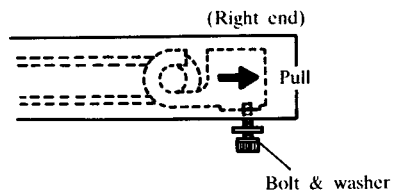

Fig. 83

- (5) Mount the right and left cover with the bolt (5×25) with the washer (Fasten temporarily) (Refer to Fig. 84)

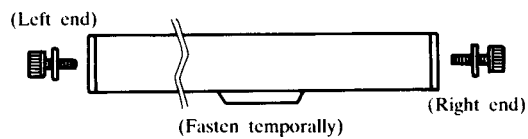

Fig. 84

### 13.2 Mounting The Motor Head

- (1) Insert the driving shaft into the hole of driving pulley with adjusting the position and fasten with three bolts. (Refer to Fig. 85, 86)

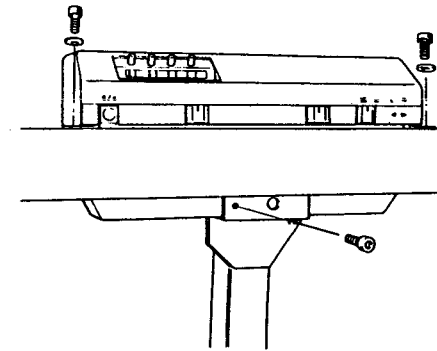

Fig. 85

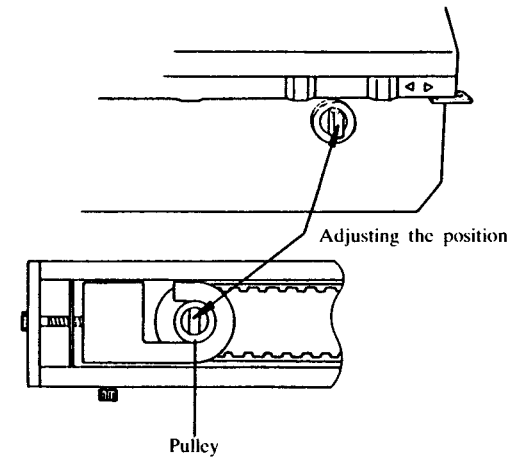
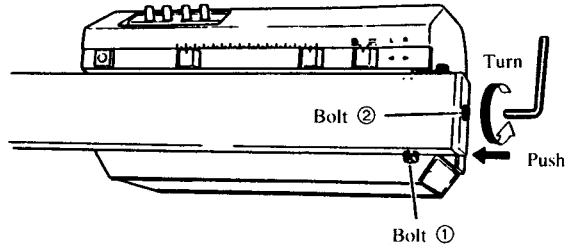

Fig. 86

## 14. ADJUSTING THE TENSION OF DRIVING BELT

### 14.1 Loosen the Safety Lock for Transportation

- (1) Loosen the bolt ① by turning it by 2 or 3 revolutions. Then while pushing the end cover (right side) to the left not to remove it from the rail, turn the bolt ② counterclockwise by 3 revolutions.
- (2) Push both right end cover and bolt ②, and fasten the bolt ① by the wrench.
- (3) Turn the bolt ② clockwise by 2 revolutions.



### 14.2 Adjust the Tension of Driving Belt (Refer to Fig. 88)

- (1) Place the shuttle at the center of rail. Loosen the bolt on the opposite side of the motor head by the wrench until the belt touches the upper part of the shuttle.
- (2) Then turn the bolt clockwise by 3.5 revolutions.

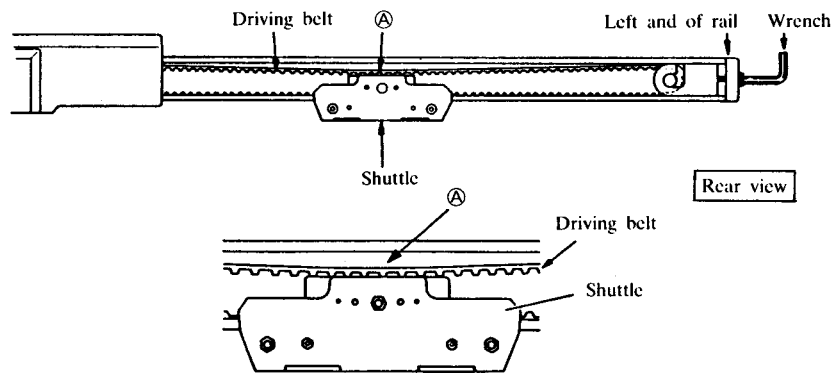

### 14.3 In case the Adjustment of the Tension of the Belt Is Difficult.

In the item 14-2, during the adjustment, if you feel heavy to turn the bolt before you turn it by 3.5 revolutions, or if after adjusting the tension, the shuttle does not move smoothly. This is caused by the extended driving belt after long use.

In this case, shorten the belt according to the following instructions.

- (1) With referring to the illustrations item 6 on page 8 remove the motor from the rail.
- (2) Remove the driving belt from the shuttle. (Refer to the items 10 and 11)
- (3) Cut off the one rack of the belt with sharp knife. (Refer to Fig. 88-2)
- (4) Mount the belt to the shuttle and assemble motor and the rail. Then adjust the tension of the belt with referring to the instructions item 12-2 and 14-2.

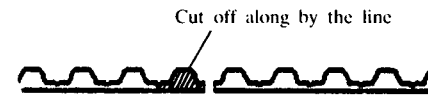

# 15. CHECKING THE FUNCTION OF THE ROW COUNTER

\*Make sure that the main power switch is turned off.

## 15.1 Checking the Function of the Row Counter

- (1) Remove the motor head cover.
- (2) Remove the row counter.
- (3) Push the Operation stud to the direction of arrow indicated in the Fig. 89. If the number is decreased by the action of stud on each time, the function of row counter is in order.

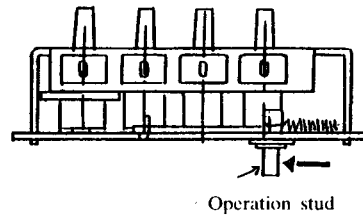

Fig. 89

## 15.2 Checking the Operation of the Row Counting Mechanism

- (1) Check up the location of the Feeding latch. (Refer to Fig. 90)
- (2) If it is in the wrong location. Remove the Control panel and correct it by using the screw driver from under between the head frame and the rail.
- (3) Move the shuttle so as to place the Row counter operation lever on the right end.
- (4) Set the Row counter assembly, the sub cover and the row counter cover to the head frame, then fasten them with the screw (3×16).
- (5) Check up the operation of the Row counter. If you move the Shuttle to the right and the left about 30 cm, the number will be decreased by the movement of the shuttle.

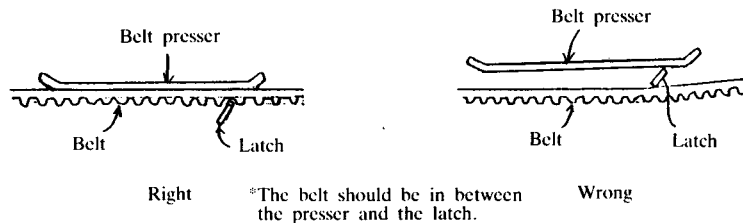

Fig. 90-1

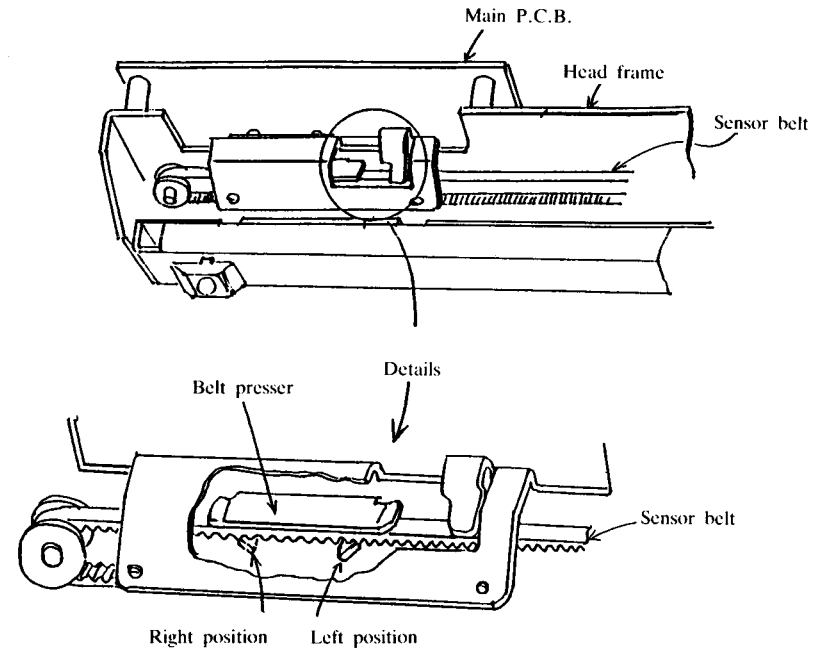

Fig. 90-2

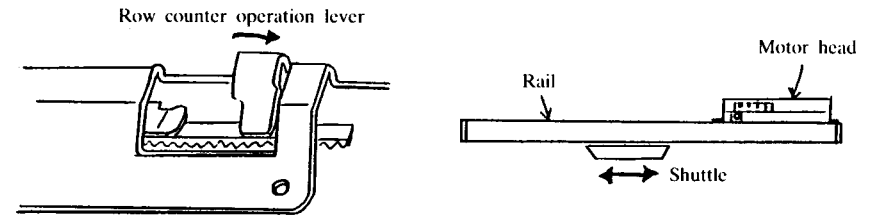

Fig. 92

Fig. 91

# 16. CHECKING THE ELECTRONIC PARTS

## 16.1 Checking the Power Supply

Check each items according to below flow chart.

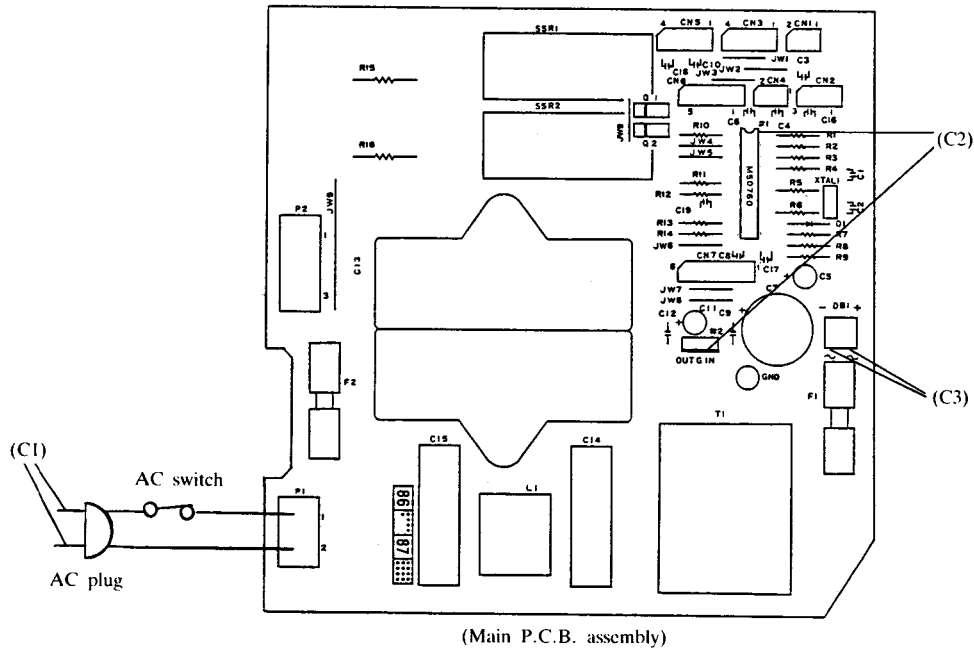
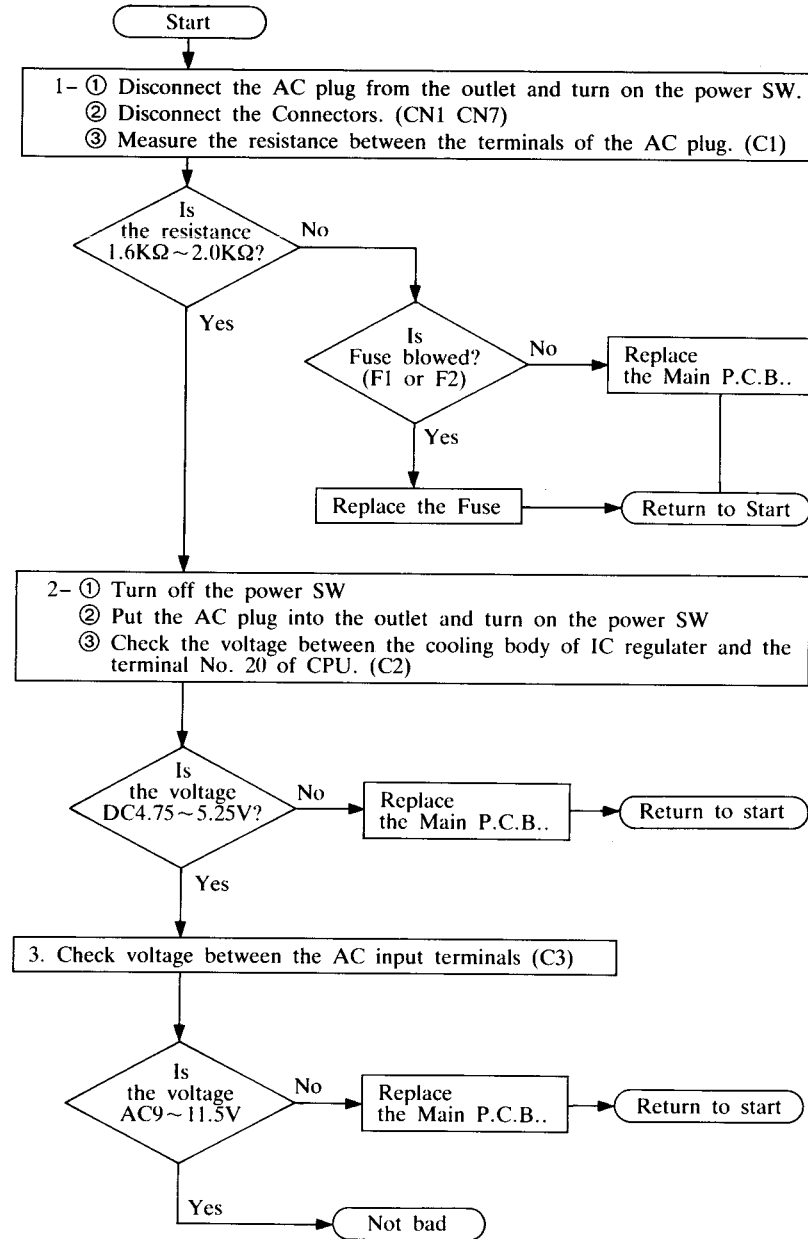

Fig. 93



## 16.2 Checking the Stator Windings of the Motor

\*In case the motor does not run or runs in unusual speed, check each resistance according to the following table and if there are any defects, please replace the motor. (Check with a electric tester.)

Checking point	110V	120V	220V	230V/240V
Between "C" & Black	8-11Ω	10-15Ω	40-60Ω	30-52Ω
Between "C" & Blue	8-11Ω	10-15Ω	40-60Ω	30-52Ω
Between Black & Blue	16-22Ω	20-30Ω	80-120Ω	30-52Ω

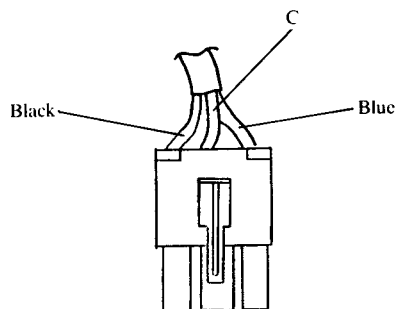

C..... Brown 110V  
Gray 120V  
Yellow 220V  
Red 240V

Line C's color is different between each voltage.



### 16.3 Checking the Yarn Sensor Function

(In case that Yarn sensor dose not work properly)

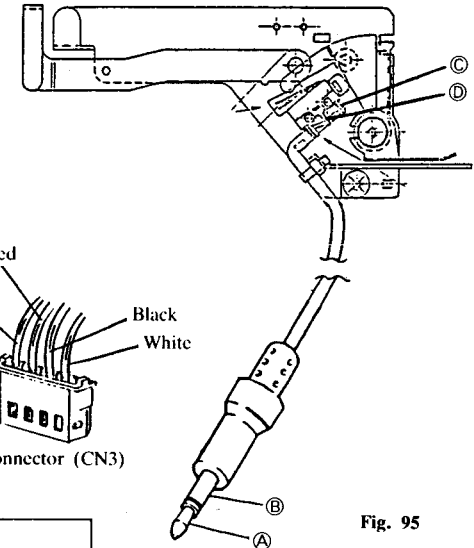
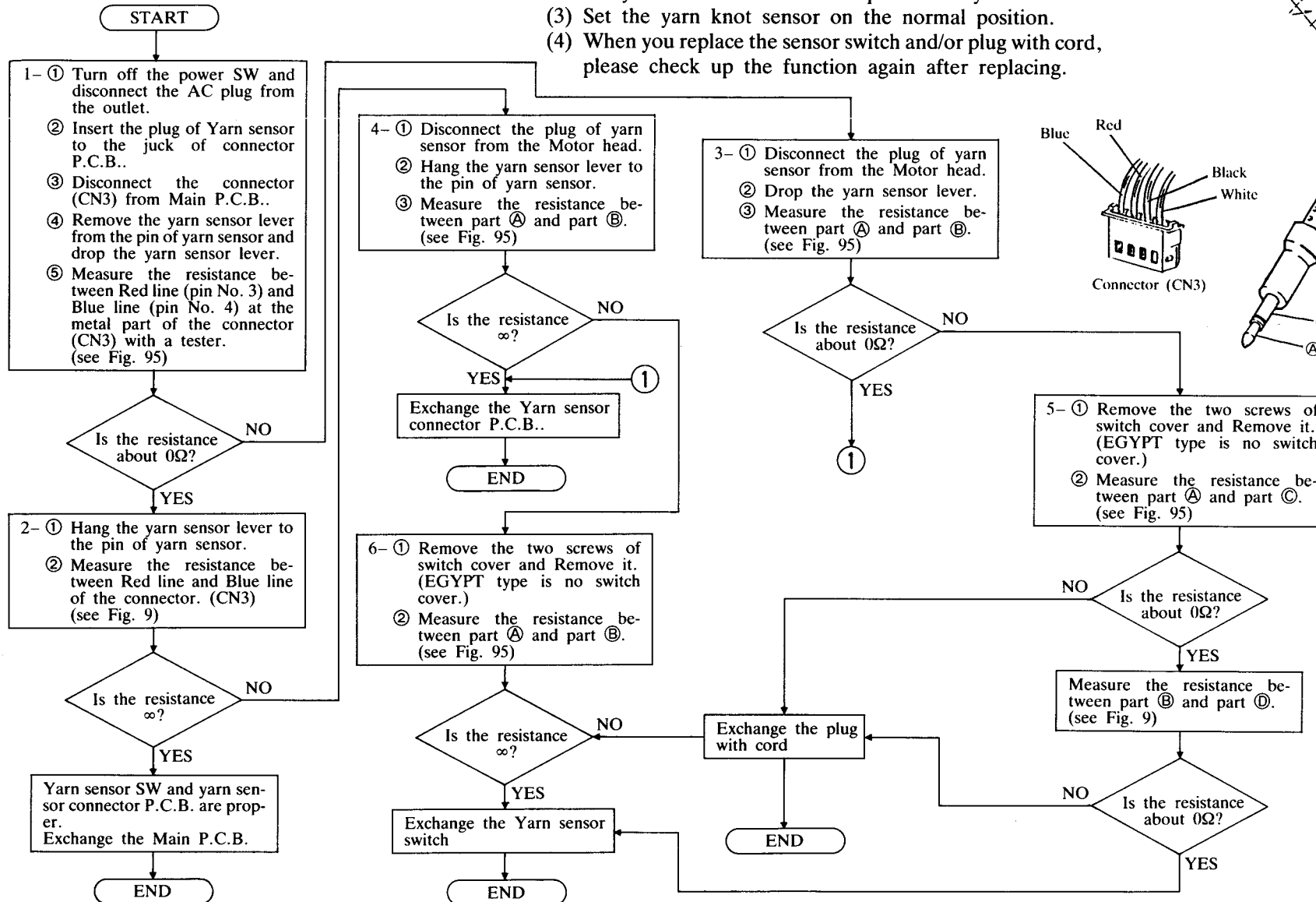

Fig. 95

- (1) Insert the troubled plug to the jack of the connector.
- (2) Remove the yarn from the Yarn tension unit, and hang the yarn sensor lever on the pin of the yarn sensor.
- (3) Set the yarn knot sensor on the normal position.
- (4) When you replace the sensor switch and/or plug with cord, please check up the function again after replacing.

## 16.4 Checking up the Jam Sensor Assembly and Its Correction

\*The function of the Jam sensor

While knitting, if the knitting carriage jams by the tangled yarn and so forth, the coupler releases the carriage to keep the machine away from the damage and the Shuttle (Motor) will be stopped by the Jam sensor.

The Jam sensor is a kind of switch, when the Part ① is forced to come in contact with the part ② by the lever on the reverse side of the coupler, the pulse to stop the motor immediately will be made and sent to the C.P.U.. (Refer to Fig. 96)

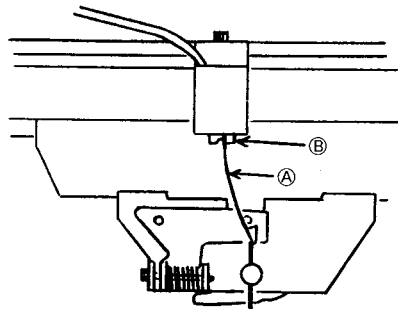

Fig. 96

### 16.4.1 Incase the Jam sensor works even by the vibration of the motor.

- (1) The Jam sensor is too sensitive, since the clearance between the part ① and ② is too narrow. The best condition is as following illustrations. (Refer to Fig. 98, 99)

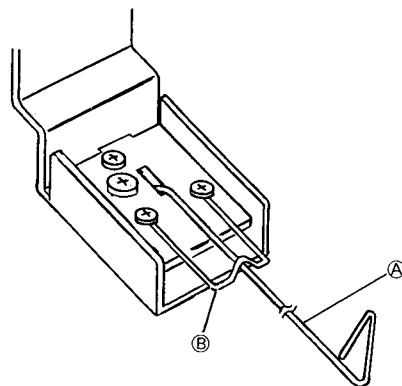
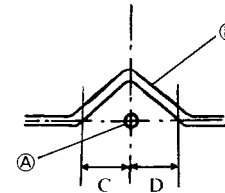

Fig. 97

Part ①: Jam sensor  
Part ②: Jam sensor contactor



$C \doteq D$

Fig. 98

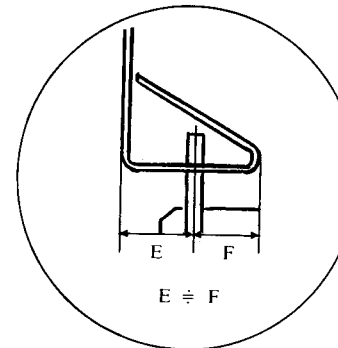

$E \doteq F$

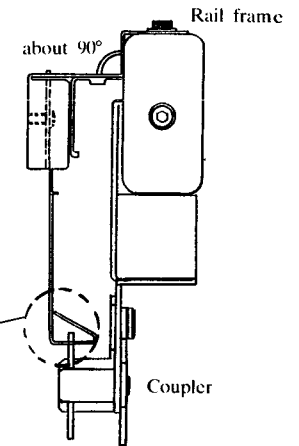

Relative parts for the Jam sensor.

Fig. 99

### (2) Wrong conditions

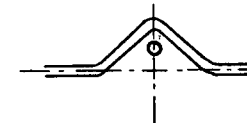

Part ① is bent inside.

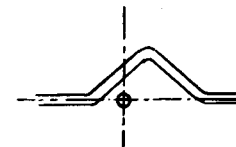

Part ① is bent to right or left.

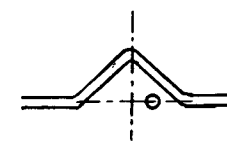

Part ② is bent to right or left.

(3) Corrections

Please make necessary corrections after removing the part ① and part ② from the Jam sensor base. To remove above parts, remove the screw ① and collar, then take out the Jam sensor supporter. And then remove three each of the screws ② and the nut so that the part ① and ② come off. Correct the bent position by using the pliers.

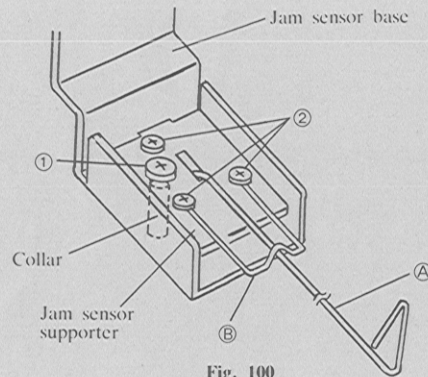
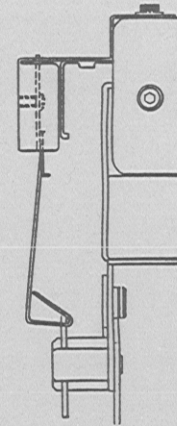
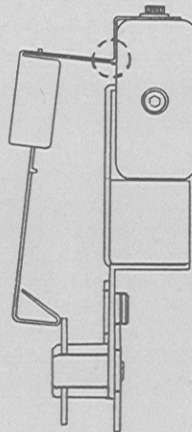

Fig. 100

16.4.2 In case the Jam sensor never work

- (1) The Jam sensor is too dull, since the clearance between the part ① and ② is too wide and/or the part ① is bent and is off its correct position.
- (2) Wrong conditions

Jam sensor base is bent, so the part ① never touch the lever.



Part ① is bent

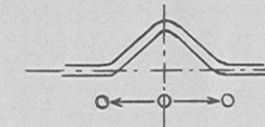
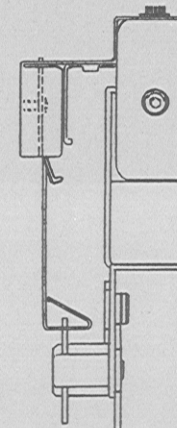

Part ② is bent

(3) Corrections

Remove the Part ① and part ② (refer to the item 16-4-1) and correct them with pliers.