

english

# PASSAP<sup>®</sup> duomatic 80



# The Instruction Book

---

## **DUOMATIC 80** **is made up of two parts:**

### **I. Basic knitting operations**

This first part contains all the explanations you will need to knit garments.

To help you find what you are looking for quickly, each page has a black edge across the top with the key word imprinted on it.

### **II. How to knit garments**

This second part explains how to knit a sweater and a skirt to fit a 3-year old, plus other attractive items. If you follow the instructions, you will very quickly grasp the basic principles, allowing you to take full advantage of all the possibilities offered by the DUOMATIC 80.

# List of contents

## All you need to know about

- 4 The machine
- 8 The lock
- 12 The needles, the pushers
- 14 Threading the yarn

## How to knit garments

- 18 **1st test piece: The basic stitch patterns knitted on both beds, increasing and decreasing.**  
As used for kitchen or fireplace mitt.  
Suggestion = slippers
- 25 **2nd test piece: Knitting a border, knitting in stocking stitch, increasing and decreasing in stocking stitch.**  
As used for sweater back for a child.
- 28 **3rd test piece: Round neck knitted in stocking stitch.**  
As used for sweater front for a child.
- 30 **4th test piece: Graduations (short rows).**  
As used for child's skirt.
- 32 **5th test piece: Tubular and half tubular knitting.**  
As used for child's hat.
- 33 **6th test piece: Fancy stitch patterns.**  
As used for children's bag.

# Basic knitting operations

## 37 Basic stitch patterns

Stocking stitch – Knit/Knit – 1:1 rib – 2:2 rib – Fisherman's rib – Half Fisherman's rib – Tubular – Half tubular – Long stitch.

## 40 Transfer of stitches

One stitch to the adjacent needle – from rib to stocking stitch – using dekkercomb.

## 42 Casting on

Double-bed: With racking – tubular – tubular for 1:1 rib – tubular for 2:2 rib.

Single-bed: Simple cast-on – with pushers – tubular closed – tubular open – half tubular.

## 47 Casting off

Double-bed: By transferring the stitches – without transfer of stitches.  
Single-bed: By using the green tool – by hand.

## 50 Increasing

One stitch at the edge – one to three stitches in from the edge – one stitch at the centre – double-bed: several stitches at the same time – single-bed: several stitches at the same time – several stitches with a contrasting piece of knitting.

## 53 Decreasing

One stitch at the edge – one to three stitches in from the edge – one stitch at the centre – several stitches in single-bed knitting – several stitches in double-bed knitting.

## 55 Graduations (short rows)

Decreasing from the right – decreasing from the left – increasing from the left – increasing from the right – bust darts – knitting on the same row in two colours diagonally – intarsia.

## 60 Necklines

Vertical slit – V-neck – Round neck.

## 62 Buttonhole

## 63 Fancy stitch patterns

---

## 74 Socks

## 75 Sweater

---

## 80 Making up

Pinning out to size and pressing – seams.

## 82 Calculation of garments

Test square – calculating the stitches and rows – calculating increases and decreases.

## 86 Technical hints

Jammed lock – dropped stitches – loops at the edges – too tight or unknitted edge stitches – pushers in wrong position – replacing a needle – damaged yarn.

How to clean the machine.

# The machine

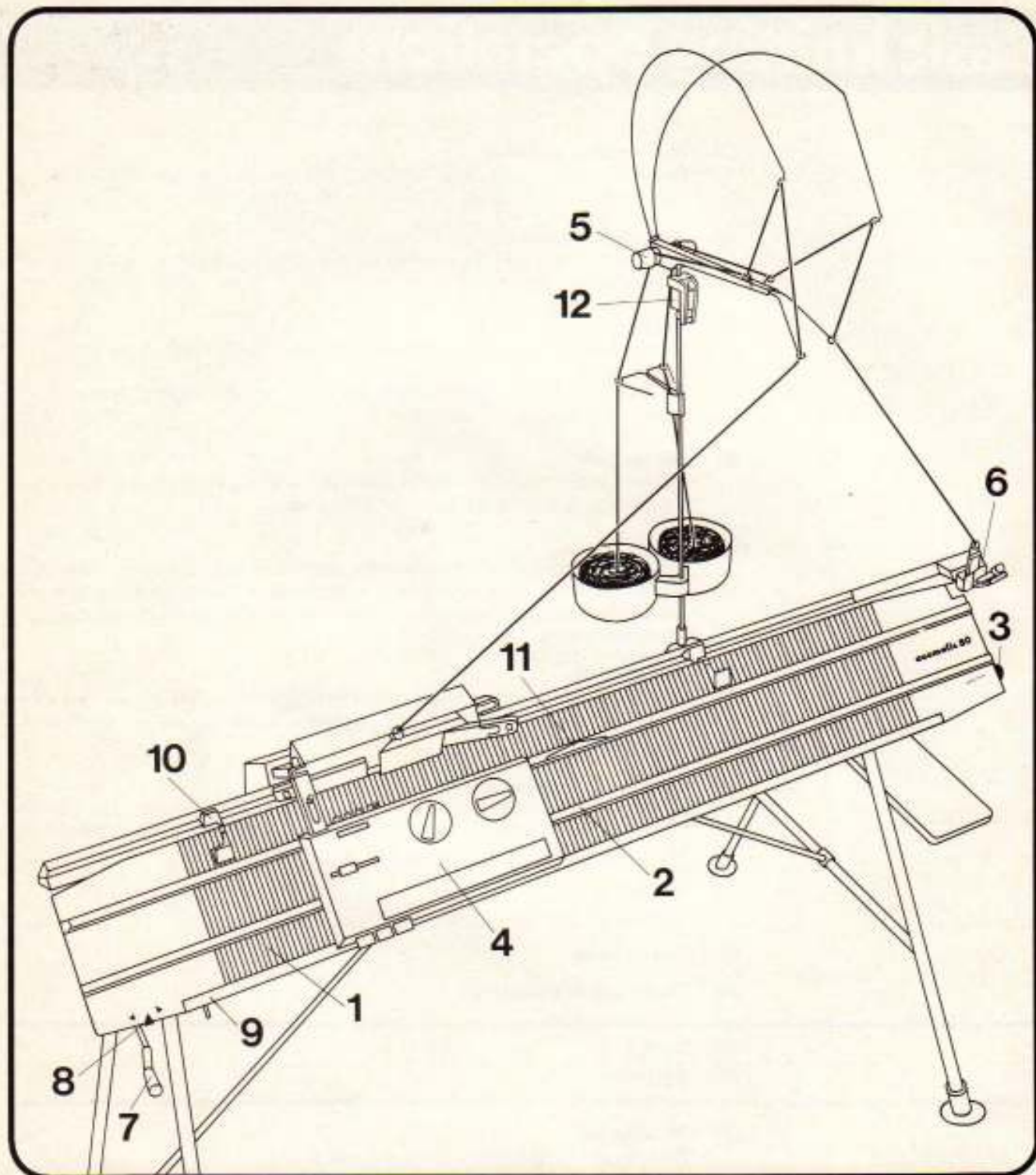

Here the most important parts of the machine:

## 1 The needle beds

Front and back bed each having 179 needles.

## 2 The needle scale

Starting from the centre all needles are numbered to facilitate counting of the stitches.

## 3 The knob for lowering front bed

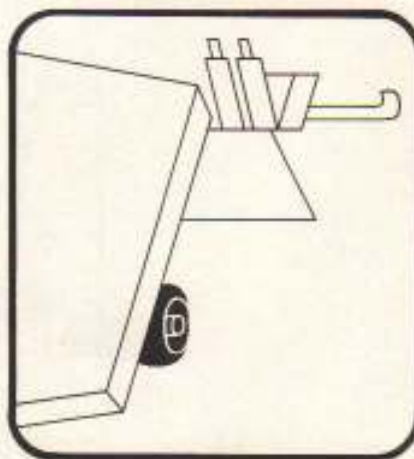

It is situated at the right underneath the front bed.

**To lower the front bed**, pull the knob to the right.

**To return the beds to their normal position**, push the front bed up and the knob to the left simultaneously.

## 4 The locks

They are the most important parts on the machine. Their functions are explained on pages 8 to 11.

## 5 The yarn guides

Threading and setting these are explained on pages 14 and 15.

## 6 The colour changer

It changes the yarns automatically. Its use is explained on page 16.

## 7 The racking handle

It serves to move the back bed sideways in relation to the front bed – in either direction.

**The racking handle has two positions in knitting: up or down.**

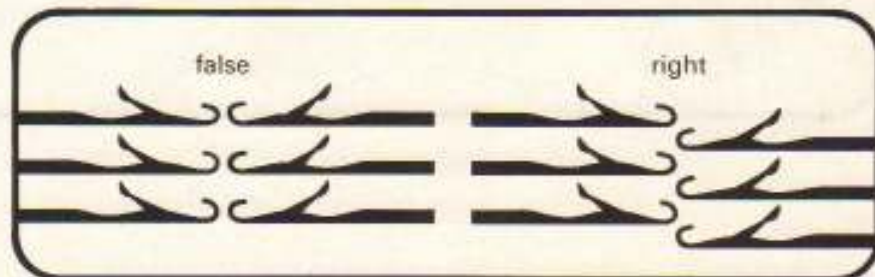

**Important Note:** When the racking handle is in the "up" position, working needles must face empty channels.

# The machine

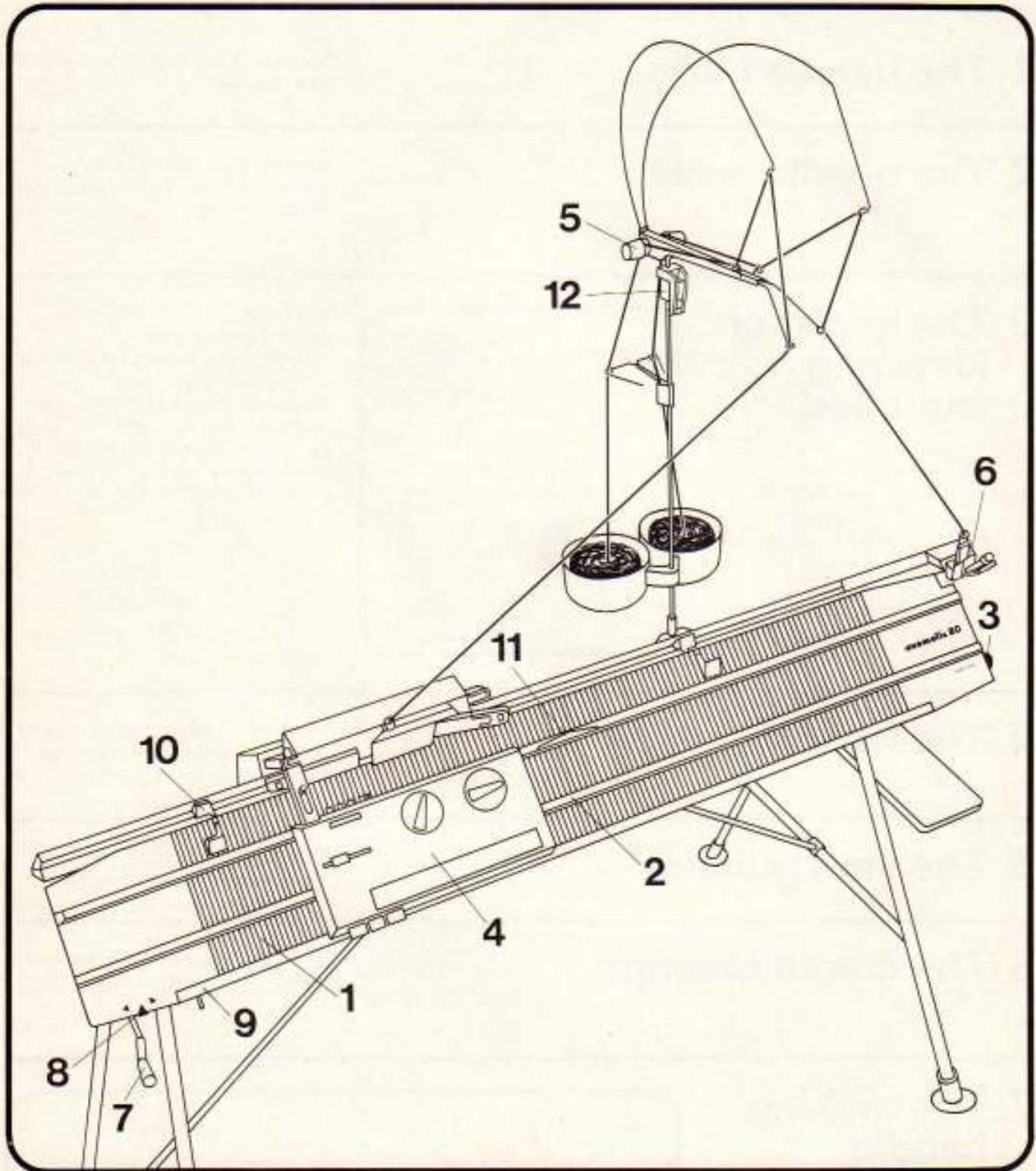

## 8 The racking indicator

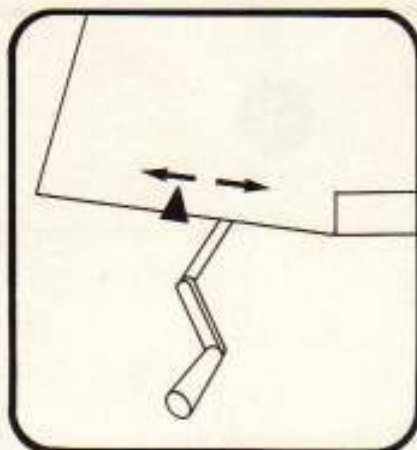

The metal indicator, situated at the bottom on the left of the front bed, indicates the direction of the last racking movement.

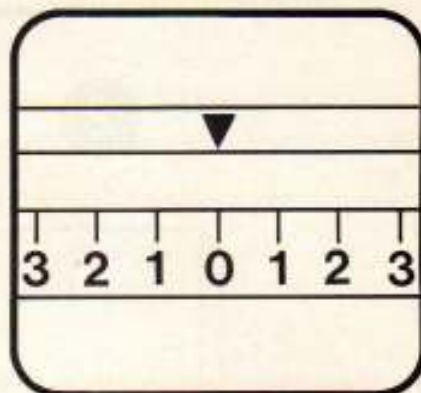

At the top on the left of the front bed, there is a scale which indicates the number of rackings that are possible in either direction. The normal position is in the middle.

## 9 The blocking rail

Its use is fully explained on page 13.

## 10 The four edge springs

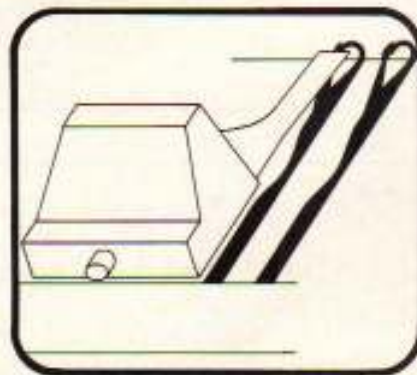

Two on each bed:  
They must always be placed on the edge needles in Working Position, their **latches closed**.

## 11 The trip cam for the row counter

It operates the row counter each time the lock moves across it. Its normal position is at the centre of the knitting. Its position is adjustable.

## 12 The clip for the guide sheet

It serves to hold the guide sheet, or any other notes during knitting.



# The lock

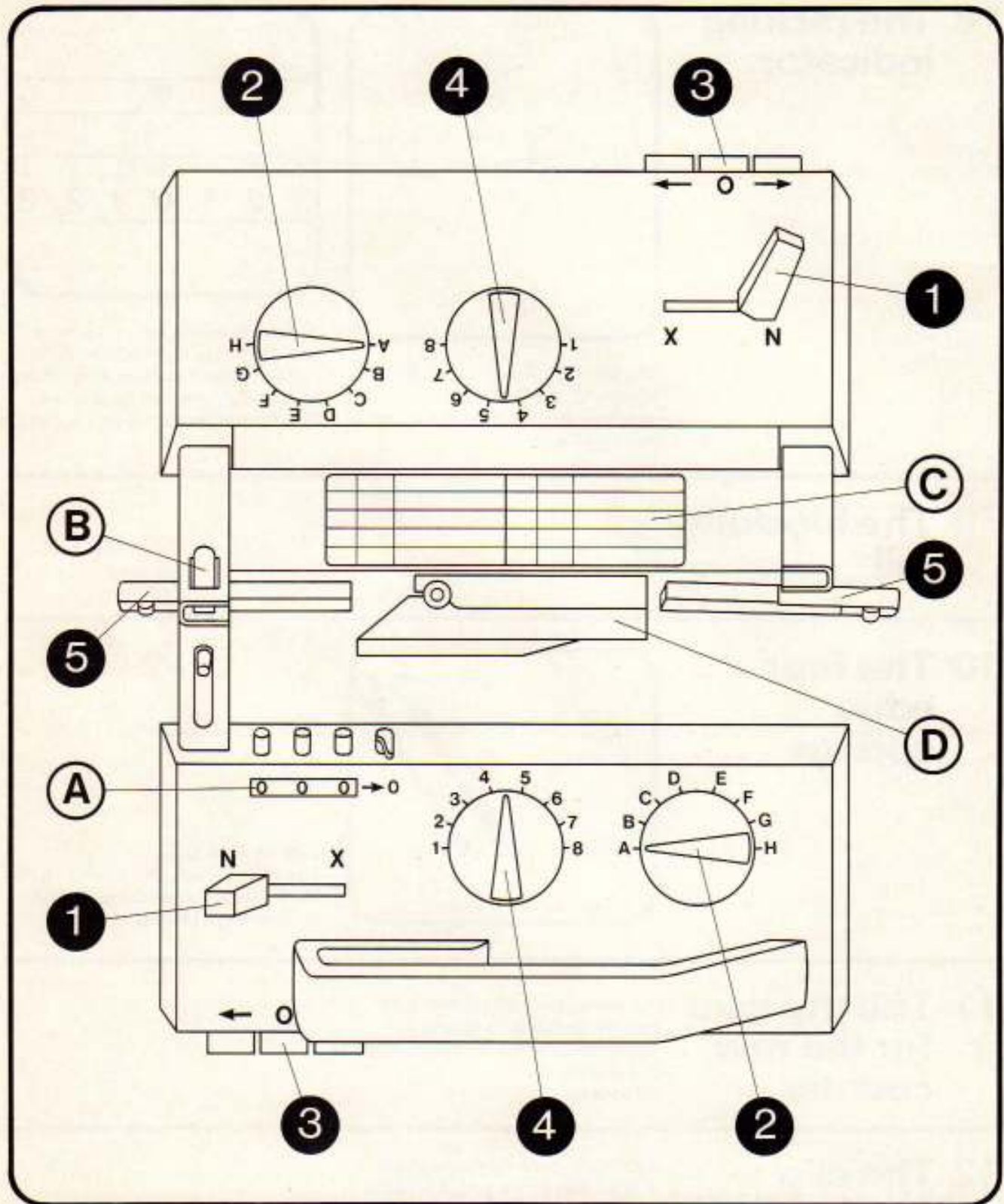

The most important parts of the locks are:

## 1 The N-X lever

**Position N:** The machine knits normal knitting, i.e. rib – stocking stitch.

In this position the pattern selector dial does not work, regardless of its setting.

**Position X:** Used in conjunction with pattern selector dial to create patterns in knitting.

Abbreviations:

**Lock**  $\frac{N}{N}$  = back lock, N-X lever on N  
 $\frac{N}{N}$  = front lock, N-X lever on N

## 2 The pattern selector dial

It is used to knit various patterns and only works when the N-X lever is set at X.

To turn the pattern selector dial, N-X lever must be on N.

Abbreviations:

**Lock**  $\frac{CX}{N}$  =  $\frac{\text{back lock, pattern selector dial C}}{\text{N-X lever on X}}$   
 $\frac{N}{N}$  = front lock, N-X lever on N

## 3 The arrow keys

According to instructions press down either the right or the left arrow key, or both together.

To release the arrow keys, press key O.

Abbreviations: back lock, pattern selector dial B  
 N-X lever on X

**Lock**  $\frac{BX \leftrightarrow}{BX \leftarrow}$  =  $\frac{\text{left and right arrow keys}}{\text{front lock, pattern selector dial B}} \frac{\text{N-X lever on X}}{\text{left arrow key}}$

## 4 The stitch size regulator

The setting of the stitch size regulator depends on the type of yarn and the pattern used.

Approximate settings (for ordinary but not fancy yarns) are given in the table opposite.

Material	Length metres per 100 g	Stitch size		
		Stocking stitch	K / K	1:1 rib
Sports yarn	310–320 m	5 $\frac{3}{4}$ –6 $\frac{1}{4}$	4 $\frac{1}{2}$ –4 $\frac{3}{4}$	3 $\frac{1}{2}$ –4
Medium wool	430–440 m	4 $\frac{3}{4}$ –5 $\frac{1}{4}$	3 $\frac{3}{4}$ –3 $\frac{1}{2}$	2 $\frac{1}{2}$ –3
Industrial yarn	800 m	3 $\frac{3}{4}$ –4 $\frac{1}{4}$	1 $\frac{3}{4}$ –2	

## 5 The strippers

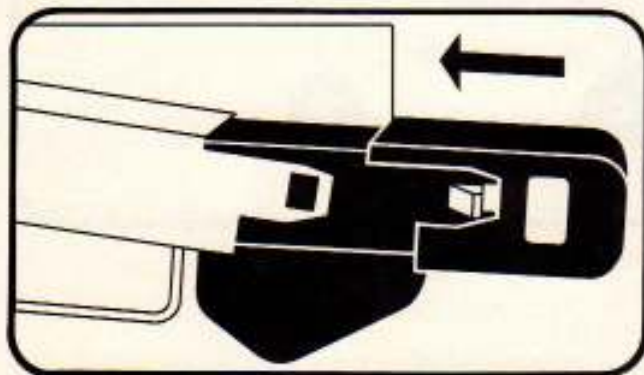

During knitting there must always be two identical strippers in their respective holders.

Insert the strippers, in the direction of the lock, into their respective holders until the small latch clicks into place. To remove the strippers, depress the small key, and pull out.

**Orange strippers for double-bed knitting.**

**Black strippers for single-bed, tubular and half tubular knitting.**

Also for special patterns see instructions.

# The lock

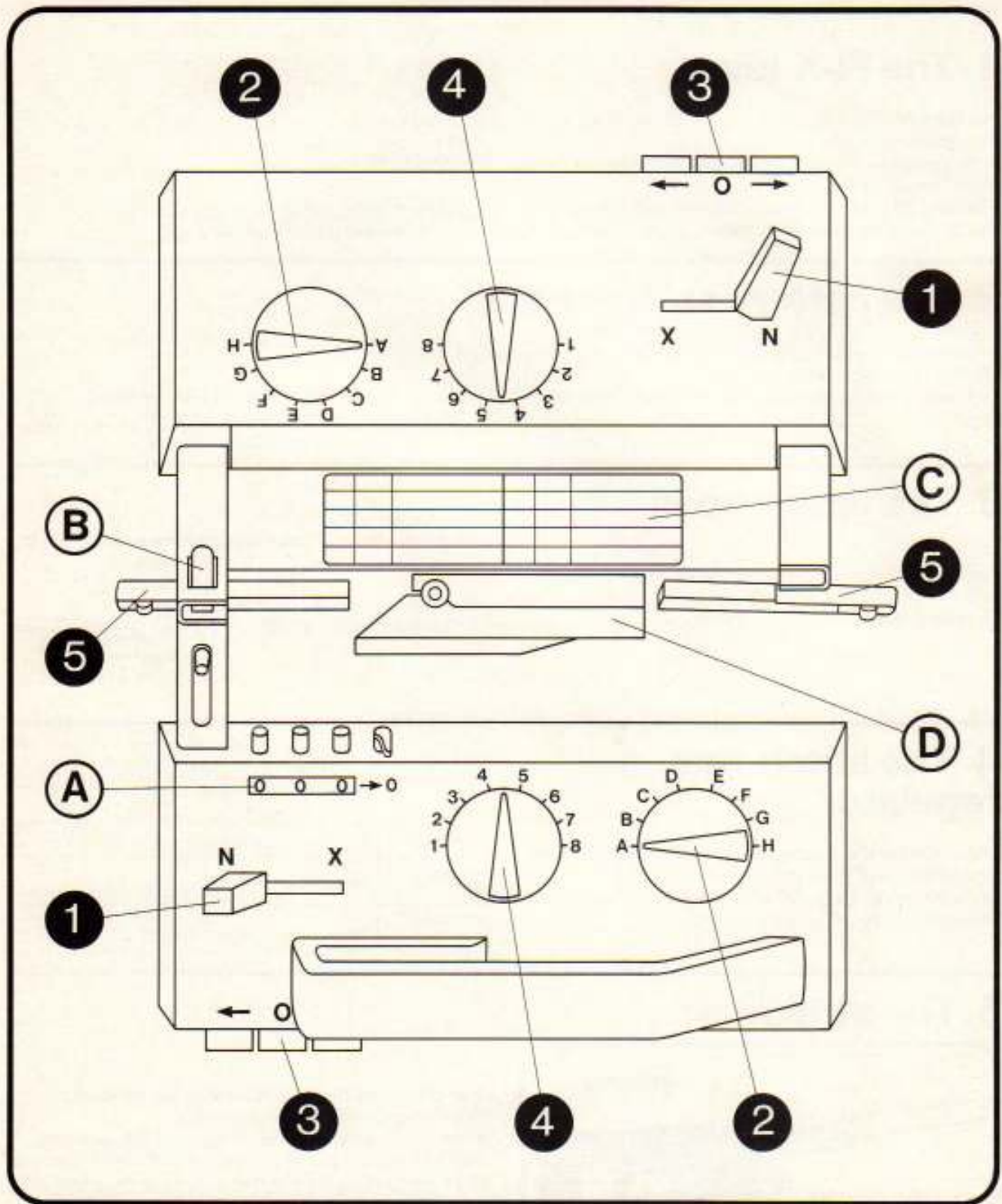

## A The row counter

Each figure on the row counter can be set individually with the aid of the corresponding knob. By pulling the small lever by the side of the three knobs to the right, all the figures can be returned to zero at the same time.

**Always remember to put back the row counter to zero before you start knitting.**

## B The connecting bolt

Push the bolt down to separate the two locks. Push the bolt up to join the two locks.

## C The diagram

Place the adhesive diagram which has been provided as a memory-help on the top of the lock.

## D The jaws for the feeding eyelets

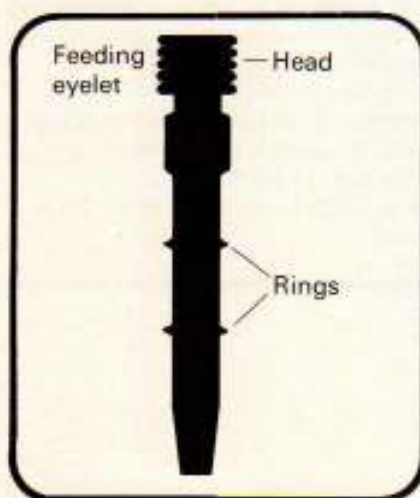

The colour changer automatically brings the feeding eyelet into the correct position in the scissor-like jaws.

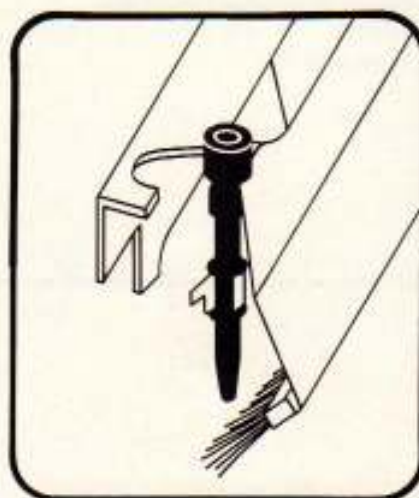

If the feeding eyelet has to be put in manually, open the jaws and insert the feeding eyelet in such a way that the jaws will securely hold it between the two rings.

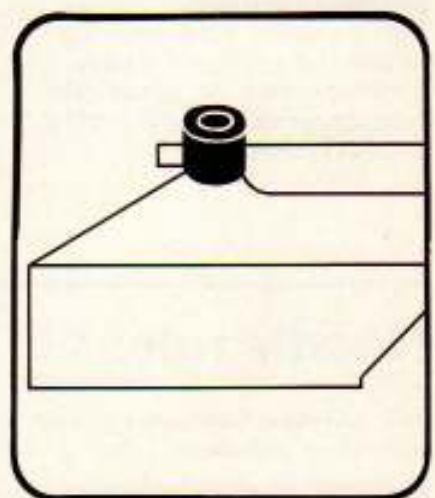

**Important: Once the jaw is shut, only the head of the feeding eyelet should be visible. If this is not the case, start again.**

# The needles and pushers

## The Needle

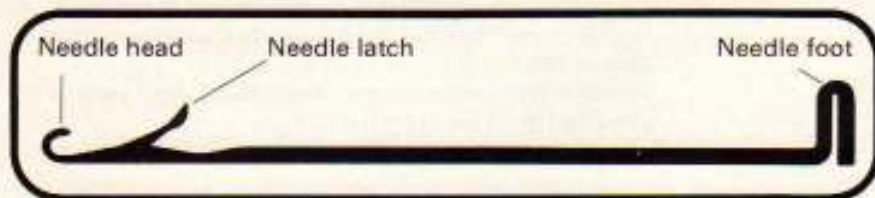

The needles have two positions

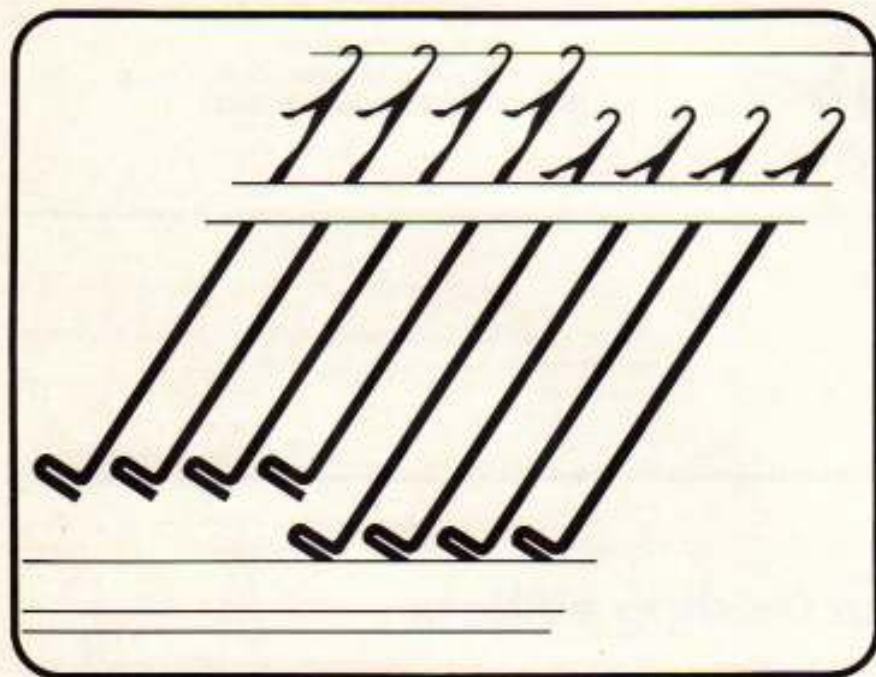

### Working Position:

Here the feet of the needles are approx. 1,5 cm ( $\frac{5}{8}$  inch) away from the needle rail. The needle heads must be level with the top edge of the beds.

### Out of Working Position:

Here the feet of the needles touch the needle rail.

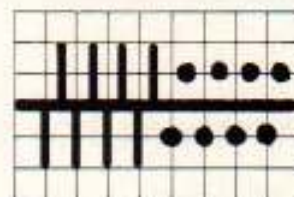

### An example of needle positions:

Vertical lines above the horizontal line = needles are in Working Position on back bed.

Vertical lines below the horizontal line = needles are in Working Position on front bed.

• = needles out of Working Position.

## Needle rule:

This rule **must** be observed when knitting on both beds.

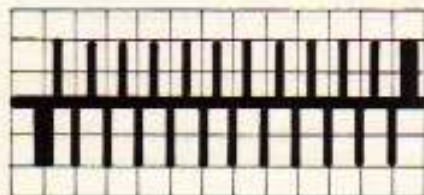

Last needle at right = on back bed

Last needle at left = on front bed

# The needles and pushers

## The Pusher



The pushers have three positions

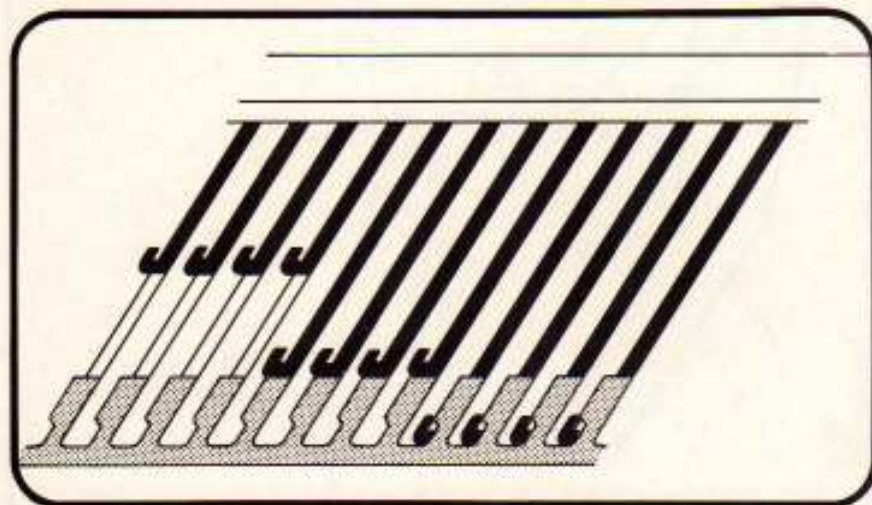

**Working Position:**  
The feet of the pushers are approx. 1,5 cm ( $\frac{5}{8}$  inch) away from the blocking rail.

**Rest Position:**  
The feet of the pushers touch the blocking rail.

**Out of Working Position = In the blocking rail:**  
The feet of the pushers are inside the blocking rail.

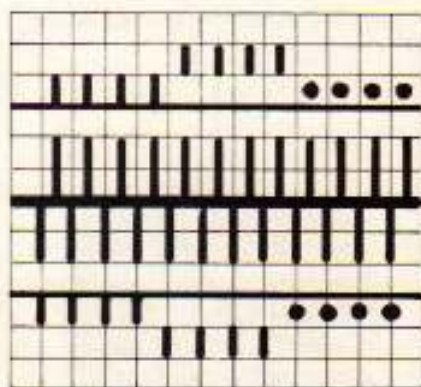

**An example of pusher positions:**  
In this example the position of the pushers is shown behind the two fine horizontal lines. Short vertical strokes touching this horizontal line = pushers in Working Position. Short vertical strokes one square removed from this horizontal line = pushers in Rest Position. • = pushers out of work = in the blocking rail.

## Moving the pushers in and out of the blocking rail

Each blocking rail has a button on its left side. Push the button of the blocking rail on the front bed to the right, and hold it there.

Now the pushers can either be moved in or out of the rail. On releasing the button the rail will close automatically. The button of the blocking rail on the back bed must be pushed to the left.



**Important: If a pusher gets caught in the upper half of the blocking rail, it will not close properly, and this will produce faults in the knitting.**

# Threading the yarn

## Waxing and winding the yarn

It is most important for the yarn to be waxed and wound properly. When winding the yarn, let it run over the enclosed piece of paraffin wax.

To obtain a correct ball, be careful not to hold the yarn too tightly.



Always knit with the end of yarn coming from the centre of the ball. If the yarn does not flow **freely** and **smoothly**, the ball has been wound too tightly, and must be wound again.

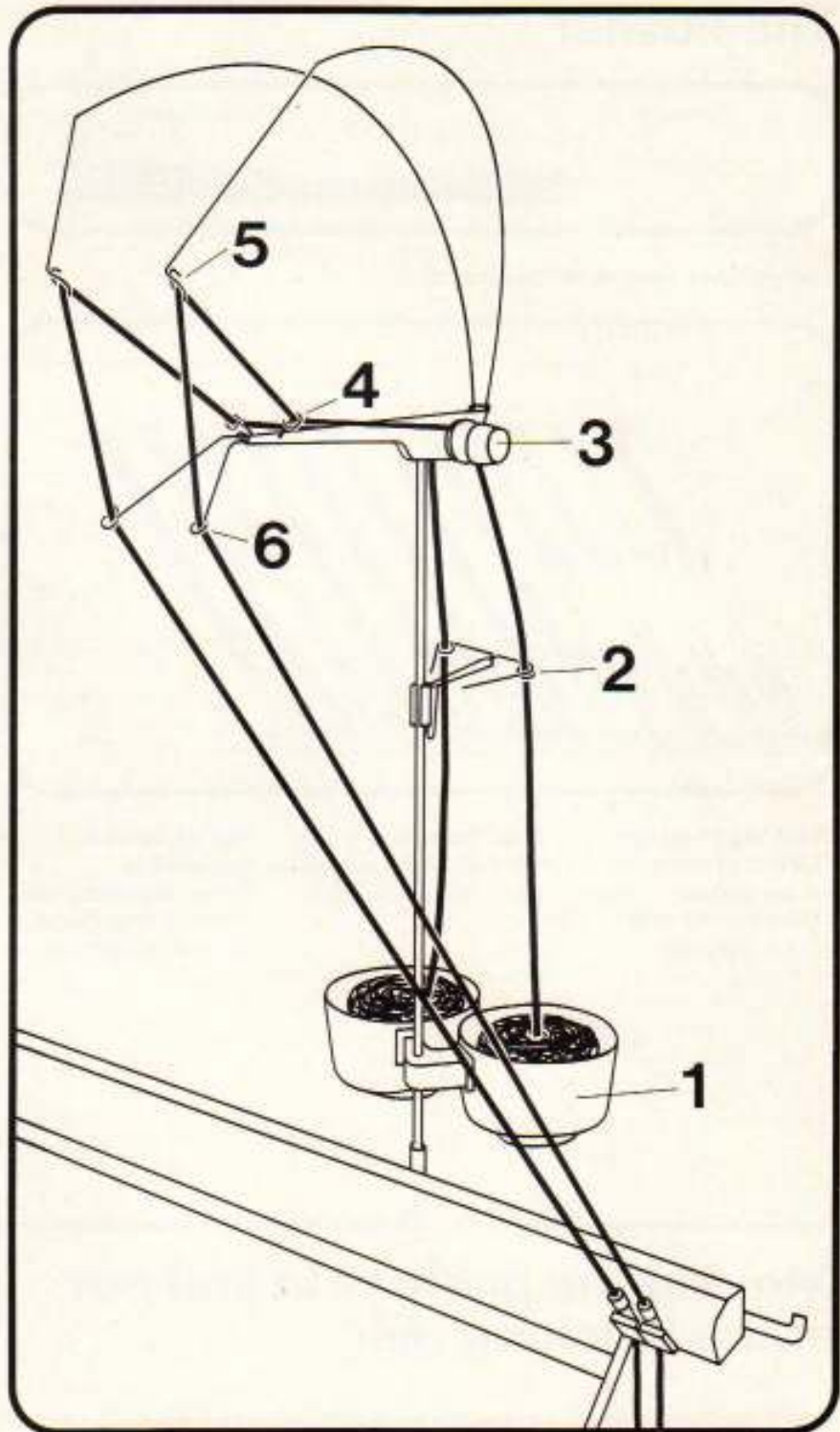

## Threading the yarn guide

- **Place each ball of yarn in its yarn holder 1.**  
Pick up the loose end of yarn coming from the centre of the ball, and insert it into one end of the double end bodkin.
- **Guide yarn through eyelet 2.**
- **Then take it between the two tension discs 3** by pulling the outer disc away slightly.

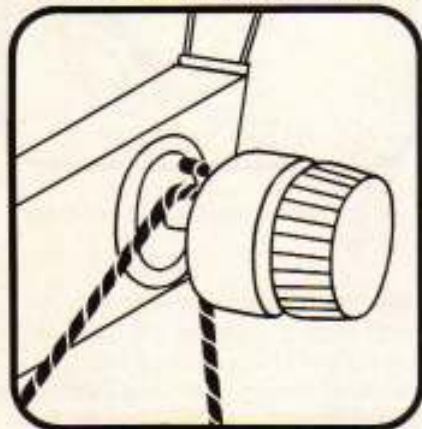

Take great care that the yarn is under the small protruding pin.

- **Guide yarn through eyelet 4**
- **Through eyelet 5**
- **Through eyelet 6**

**The tension discs** are numbered from 1 to 7. Normally, they are set at  $3\frac{1}{2}$  which suits most yarns. The above setting should only ever be altered for very thick or very fine yarns.

### General rule:

**If loops appear at the edge of the knitting, increase the setting on the tension discs to a higher number.**

**If the edge stitches are either too tight, or even not knitted, lower the setting on the tension discs.**

## Threading the feeding eyelets

**Important: The yarn of the right yarn guide goes into the right feeding eyelet, and the yarn of the left yarn guide goes into the left feeding eyelet.**

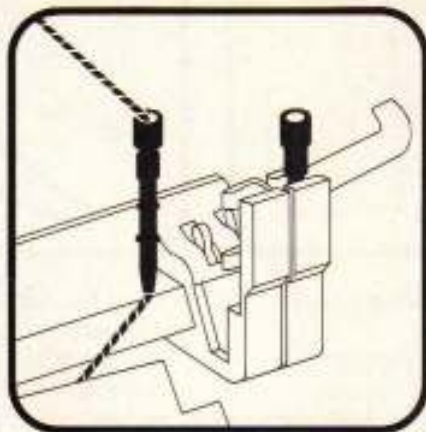

- **Pull the lever of the colour changer twice to the right.**  
Both feeding eyelets are now up.
- **Take the left feeding eyelet out of its holder** by pressing it to the left.
- **Thread it, and hold the yarn end.**
- **Put the feeding eyelet back into its holder.**

**Note: The two rings of the feeding eyelet must be between the two clips of the holder.**

- **Pass the yarn end between the two beds, and insert it in the slot on the right hand side of the front bed.**
- **Press down the holder of the left feeding eyelet.**

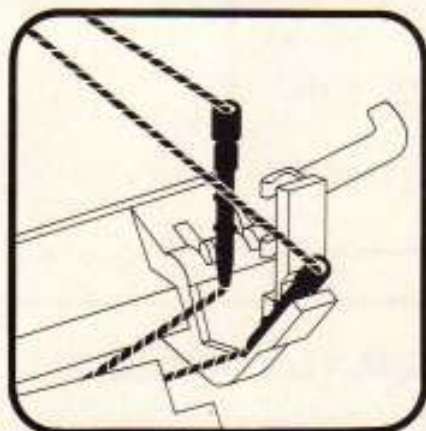

Now the right feeding eyelet can be threaded in the same way.



# Threading the yarn

## Moving the feeding eyelet into the jaws on the lock

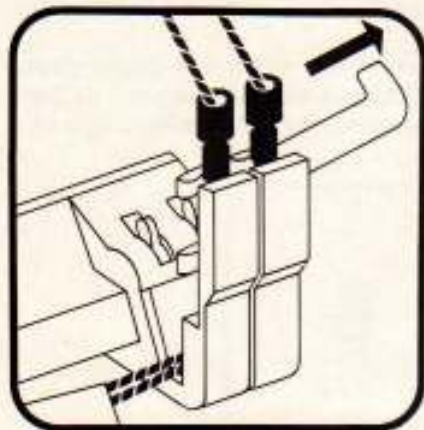

- Pull the colour changer lever twice to the right. Both feeding eyelets are up.



- Press the feeding eyelet, which you want to use first, down.
- Pull the lever of the colour changer once to the right.

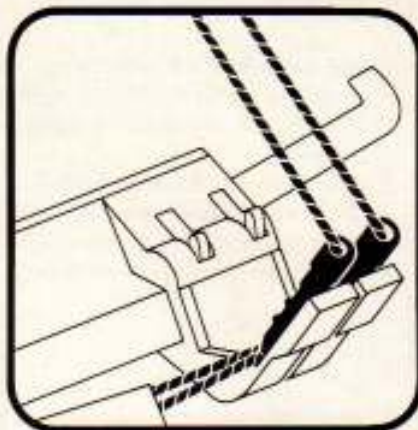

- Press down the second feeding eyelet.

Now you can move the lock to the right until it operates the lever of the colour changer, and the required feeding eyelet is automatically brought into the jaws on the lock.

## Automatic colour change

Move the lock to the right until it operates the lever. If you do not want to change colour, do not take the lock right to the end.

**Important:** Never take the lock right to the end on the right if a holder with a feeding eyelet or both holders are up. In this case put the feeding eyelets back into their respective holders by hand, and start again. Never move the lock when an empty feeding eyelet is in the jaws.

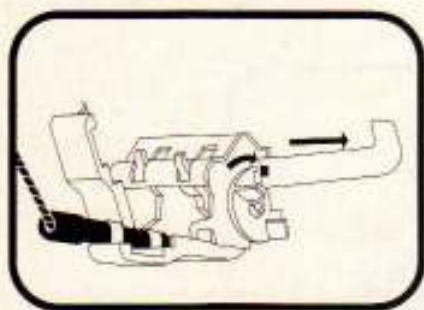

## Putting the two-colour changer out of action

- Bring the feeding eyelet with which you are going to work into the lock.
- Pull the lever of the colour changer to the right once.
- Press down both feeding eyelet holders.
- Pull the lever to the right and turn the locking disc towards the back.

## Empty lock (to release stitches)

In order to release your knitting without casting off, push the lock to the end on the right side, lower the holder with the feeding eyelet, and push the lock across the knitting without any feeding eyelets.



# How to knit garments



The following knitting course has been so designed that, while you are knitting the garments pictured here, you will easily acquire the techniques necessary to knit the designs of your own choice later on.

**Note:** For optimum results, we suggest you follow the course in the sequence in which it is written. We start with easy-to-do pieces, and build on those skills thereafter.

All the garments have been worked in a medium yarn.

(100 g = 430 m)



# 1st test piece = basic stitch patterns on both beds, increasing and decreasing



If you use the recommended yarn and follow our instructions, this first test piece will make a handy kitchen or fireplace mitt.

## Set the machine:

– On front and back bed put 22 needles into **Working Position** (p. 12).

Use the red pattern ruler.

Start from the centre of the bed (11 stitches to the right of the centre, 11 stitches to the left of the centre). Use the needle scale as a guide.

Observe the needle rule:

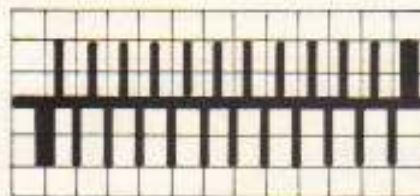

**Last needle at right = on back bed**  
**Last needle at left = on front bed**

– **Place the edge springs** (p. 7)

On the last needle at left and at right, front and back bed, **always on the closed latch.**

– **Racking handle down** (p. 5)

– **Orange strippers** (p. 9)

## How to set the lock:

Lock at right hand side.

– **Lock**  $\frac{N}{N}$

On front and back lock move N-X lever to N.

– **Stitch size**  $3\frac{3}{4}$

Stitch size on front and back lock  $3\frac{3}{4}$ .  
(If necessary adjust stitch size to thickness of yarn).

– **Row counter on zero**

Pull the lever to the right.

– **Bring the feeding eyelet into the lock** (p. 16)

The lock is now set correctly to start knitting.  
Cast on in the following ways:

## Cast-on with racking

- Racking handle one complete turn to the left
- Knit one row, move lock to the left
- Racking handle one complete turn to the right
- Knit one row, move lock to the right

This is your cast-on.

---

## Section A = Knit / Knit = K / K

- Lock at right
  - The setting on the lock remains unchanged
  - Row counter on zero  
Use even and regular movements to move the lock across the needles. Do not move the lock more than 10 cm (4 inches) beyond the edge of the knitting.
  - Knit 30 rows, i. e. until the row counter shows 30.
- 

## Section B = Fisherman's rib

- Lock at right
  - Lock  $\frac{EX}{EX}$   
On front and back lock move pattern selector dial to E, and N-X lever to X
  - Change colour  
= move the lock to the right until it operates the lever.
  - Row counter on zero
  - Knit 80 rows
- 

## Section C = Long stitch

- Lock at right
- Lock  $\frac{N}{CX}$   
On front lock move N-X lever to N  
Turn pattern selector dial to C, and return N-X lever to X  
On back lock move N-X lever to N
- Change colour
- Row counter on zero
- Knit 30 rows

## Section D = decreasing stitches in Knit / Knit

### – Lock $\frac{N}{N}$

i. e. on front and back lock N-X lever on N

### – Change colour

### – Row counter on zero

### – On each side –5x2+2.R

i. e. at each end of the knitting decrease five times two stitches every two rows.

As the stitches on both beds are counted in double-bed knitting, decreasing two stitches means: one stitch on the back and one stitch on the front bed.

### – Decrease the first stitch at right on the front bed

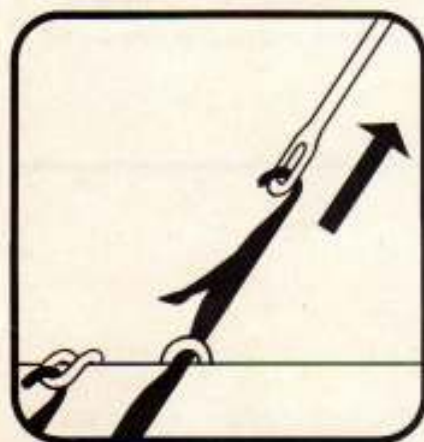

Insert the eyelet of the orange tool into the needle head which holds the first stitch. Pull the needle upwards until the stitch lies behind the open latch.



Push the needle downwards until the stitch slips over the closed latch onto the orange tool.

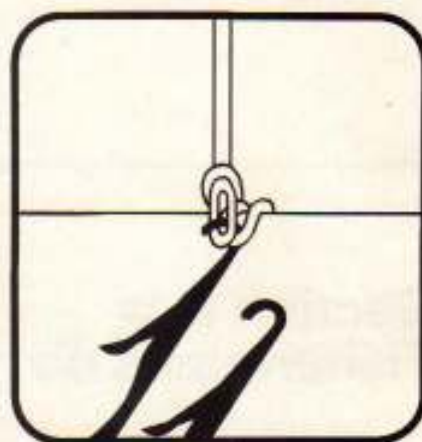

Unhook the orange tool, and place the stitch into the adjacent needle head by tilting the tool forward. Empty needle out of work = push it down until its foot touches the rail.

### – Proceed in the same way for the other edge stitches

i. e. at right on back bed, at left on front and back bed.

Now two stitches have been decreased at each end.

### – Knit two rows

### – Repeat the decreases four times more every two rows.

The row counter now reads 10.

## Section E = increasing stitches in Knit / Knit

- Lock remains unchanged
- Row counter on zero  
Do not change colour
- At each end +5x2+2.R  
i.e. at each end of the knitting increase five times  
two stitches every two rows.
- Increase the first stitch at right on the front and  
back bed  
The lock is on the right of the knitting



At the right  
edge of the  
knitting put  
one needle into  
Working Position  
on front  
and back bed.

- Knit one row
- At the left edge put one needle into Working  
Position on the front and back bed
- Knit one row  
Repeat the increases four times more every two  
rows.  
The row counter now reads 10.

---

## Section F = Long Stitch

- Lock  $\frac{CX}{N}$
- Change colour
- Row counter on zero
- Knit 30 rows





## Section G = half fisherman's rib

- Lock  $\frac{EX}{N}$
- Change colour
- Row counter on zero
- Knit 40 rows  
Reverse the setting on the lock.
- Lock  $\frac{N}{EX}$
- Knit 40 rows  
= the row counter now reads 80

## Section H = Knit/Knit = K/K

- Lock  $\frac{N}{N}$
- Change colour
- Row counter on zero
- Knit 30 rows

## Casting off

- Transfer all the stitches on the back bed to the needles of the front bed



Insert the eyelet of the double end bodkin into the needle head of the first needle in work at the right on the back bed, pull the needle upwards until the stitch lies behind the open latch.

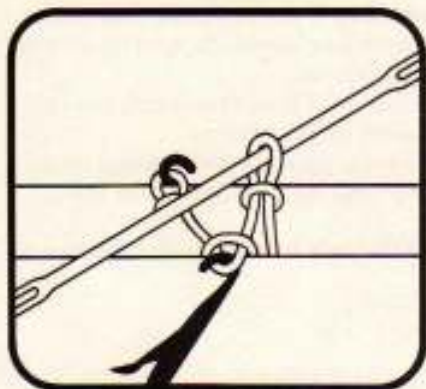

Push the needle down until the stitch slips over the closed latch onto the double end bodkin. Unhook the double end bodkin, making the stitch slide near the other end.

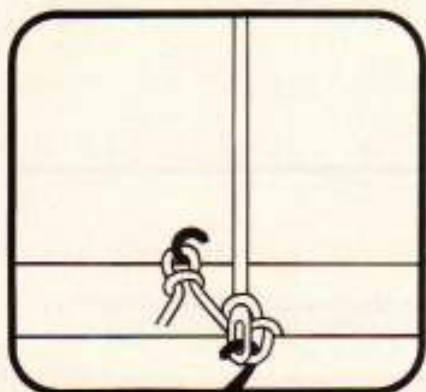

Insert the eyelet nearest you into the needle head of the needle facing it on the front bed. Tilt the double end bodkin forward in order to slip the stitch into the needle head. Leave the empty needles on the back bed in Working Position.

Repeat, until all the stitches of the back bed have been transferred to the needles of the front bed.

– **On the back lock increase the stitch size by one number**

– **Knit one row** (lock at left)

– **Lower front bed**

i.e. pull the knob which is on the right, under the front bed.

Now, with the aid of the orange tool, push the knitting towards the back bed thereby lengthening the front bed stitches as much as possible.

– **Crochet off the stitches of front bed needles, using yellow tool.**

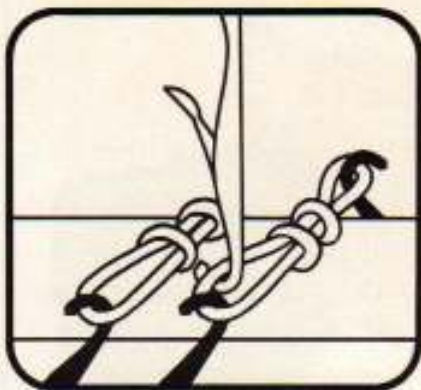

Insert the tool with its latch open into the first stitch at right on front bed.



Insert the tool from above into the second stitch on front bed in such a way that the first stitch slips behind the latch. Note: Under no circumstances must the second stitch slip behind the latch as well.

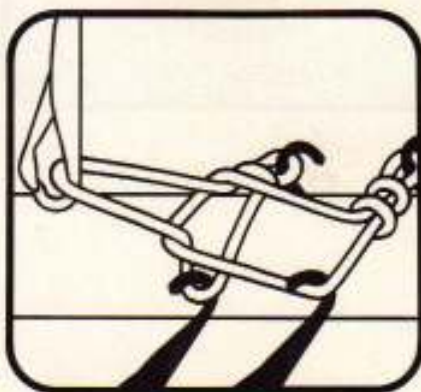

Pull second stitch through first stitch until the first stitch closes the latch, and slips over the second stitch.

You have again a single stitch in the latch needle; now repeat to end.

Ignore stitches on back bed.

Finally, break off yarn, and pull it through the last stitch.





– **To remove the knitting from the machine** push the needles of the back bed upwards, and let all the loops slip behind the latches. Pull the needles down until their feet touch the rail; you have now released your knitting. You can pull the knitting up between the two beds, and forward, to take it off the needles at the front.

With two side seams this will make a useful kitchen or fireplace mitt.



#### An idea

You are now ready to apply what you have learnt so far, by quickly knitting yourself a pair of slippers.

#### Slippers:

Cast on with racking 120 stitches (60 stitches on the front bed, 60 stitches on the back bed), (p. 19)

Then:

– Lock  $\frac{N}{N}$ , stitch size 3<sup>3</sup>/<sub>4</sub>, colour 1

Knit six rows

– Lock  $\frac{EX}{EX}$ , colour 2

Knit 56 rows

– Lock  $\frac{N}{N}$ , colour 1

Knit six rows

– **Cast off**, (pages 22, 23)

Fold the knitting in a circle, sew the cast-on edges together, and your slippers are ready for wear.



## 2nd test piece = knitting welts, knitting stocking stitch, increasing and decreasing in stocking stitch

Back of sweater with kimono sleeves, to fit a 3-year old child 98 cm (38½ inches) tall.  
We will knit the sweater front in the next section.

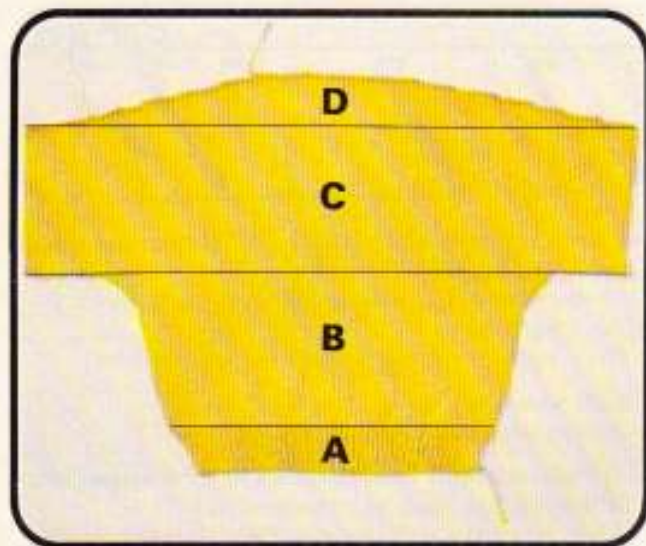

### Setting the machine:

- **94 needles in 1:1 division in Working Position**  
i.e. on front bed every alternate needle in Working Position,  
a total of 47  
on back bed every alternate needle in Working Position,  
a total of 47

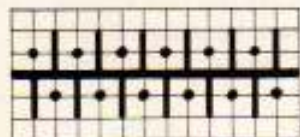

- **Racking handle up**  
The needles must be arranged in such a way that every needle in work faces a needle which is out of work, as shown on the diagram.  
Observe needle rule.
- **Place the edge springs onto the edge needles,**  
latches closed.
- **Orange strippers**
- **Row counter on zero**
- **Bring the first feeding eyelet into the jaw on the lock**

### Tubular cast-on

This type of cast-on is always used for borders and welts.

- **Lock  $\frac{N}{N}$**
- **Stitch size 1½**  
Knit one row
- **Lock  $\frac{CX}{CX}$**
- **Stitch size 2¾**  
Knit two rows
- **Lock  $\frac{N}{N}$**
- **Stitch size 3¾**  
Knit one row

Your cast-on is now completed.

### Section A

- 1:1 rib
- **Lock unchanged**
- **Row counter on zero**
- **Knit 12 rows**

### Transferring stitches from rib to stocking stitch

On front bed bring the needles which are out of work into Working Position.  
Transfer the stitches from the back bed to the empty needles of the front bed, as explained for test piece 1 (pages 22, 23).  
When there are no stitches left on the needles of the back bed, check that all the empty needles are out of Working Position.

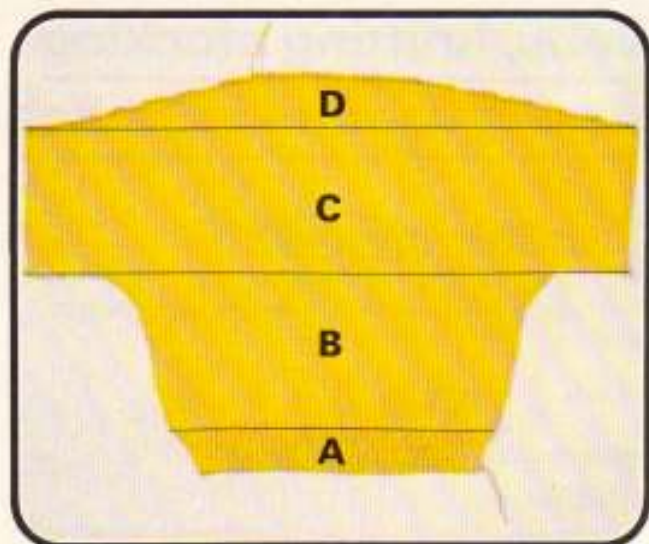

## Section B = increasing in stocking stitch

- Black strippers
  - Lock  $\frac{GX}{N}$
  - Stitch size  $5\frac{1}{4}$
  - Row counter on zero
  - At each end  $+3 \times 1 \cdot 10. R$   
i. e. at each end of the knitting increase three times one stitch every tenth row, as follows:
  - Knit ten rows  
Lock at right
  - At the right edge put one empty needle into Working Position
  - Knit one row
  - At the left edge put one empty needle into Working Position  
Continue knitting  
Repeat the increases when the row counter reads 20 and 30.  
Knit a total of 36 rows.
- Now increase as follows:
- At each end  $+6 \times 1 \cdot 2. R$   
i. e. at each end increase six times one stitch every second row.  
At the end the row counter reads 48.

## Section C = increasing several stitches

- Row counter on zero  
Lock at right
- At each end  $+18$  as follows:

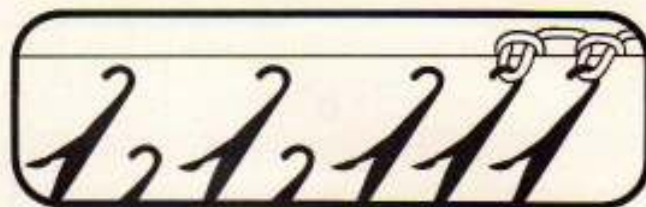

- At left end put nine needles in 1:1 division into Working Position  
i. e. the first empty needle out from the edge in Working Position.  
Then, every other needle in Working Position.
- Knit one row  
Lock at left
- At right end put nine needles in 1:1 division into Working Position, as described above.
- At left tauten the yarn by pulling it slightly to the left.



- At left bring the second half of the needles into Working Position (9 needles), in such a way that the last needle at left remains empty.
- Important: When increasing several stitches at the same time, make sure that the last empty needle is always brought into Working Position on the side where the lock is.**
- Knit one row
  - At right tauten the yarn and put nine needles into Working Position, as described above for left side.  
Check that every needle at left holds a stitch. If several needles are without a stitch, then put every alternate empty needle out of work, and only put these needles back into Working Position after you have knitted one row.
  - Knit one row  
Check that every needle at right holds a stitch. If not, proceed as described above.  
You have now increased 18 stitches at each end.
  - Knit 48 rows

## Section D = decreasing several stitches at each end = shoulder shaping

### – Row counter on zero

Lock at right

### – 6 × 9 • 2. R at each end

i.e. decrease nine stitches, 6 times, every 2 rows.

### – At right decrease nine stitches as follows:

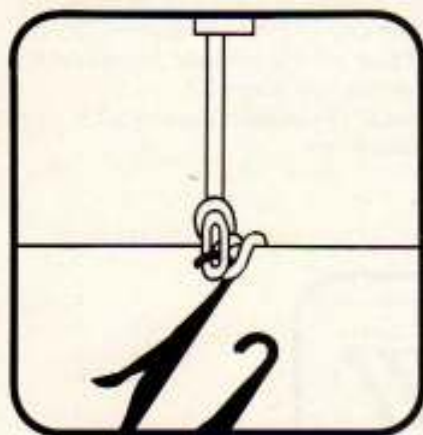

Transfer the first stitch at right onto the second needle.



Pull this needle upwards until the two stitches slip behind the open latch. Wind the yarn you have been knitting with twice round the needle, so that it once lies behind the latch and once in front of it.



Pull the needle down until the two stitches slide over the closed latch. Pull the new stitch to make it bigger than the adjacent ones, thus giving a loose cast-off.

Now transfer the new stitch onto the adjacent needle, and continue as above.

### – Cast off nine stitches in all

Transfer the last of the nine stitches on to the adjacent needle.

### – All empty needles out of Working Position

### – Knit one row

### – Proceed in the same way for the left side

### – Knit one row

Repeat the decreases five times more at left and right.

The row counter now reads 12.

You have decreased six times nine stitches at each end, leaving 40 stitches on the needles.

---

## Casting off stitches

Proceed as for decreasing stitches. At the end break off the yarn, and pull it through the last stitch.

Leaving the yarn in its feeding eyelet, pass it between the two beds, and fix it in the slot at the side.

## 3rd test piece = round neck in stocking stitch

If you wish to knit a front part to go with the back you have just completed, repeat sections A and B of the second test piece. In section C, having increased 18 stitches at each end, knit only 36 rows in stocking stitch.

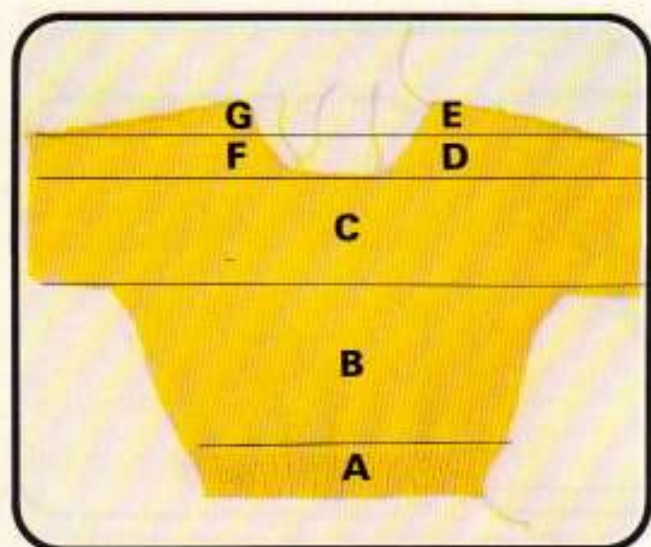

### Section D = dividing the work for the neck shaping

For the centre part of the neck **cast off 18 stitches at the centre of the knitting** as follows:

Transfer the 9th stitch at right of centre to its adjacent needle at left. Take a length of the yarn approx. 30 cm (12 inches) long, and cast off the stitches as explained for decreasing several stitches, page 27.

Finally, pull the two ends of the yarn downwards between the two needle beds.



– To the right of the cast-off stitches put for every needle in Working Position one pusher into Working Position.

Pull the blocking rail to the right, and hold it by the button on the left. Put the required number of pushers into Working Position.



**Important:** Take care that no pusher remains wedged in the blocking rail, as this would prevent it from closing properly.

– **Lock BX**

With this setting only the needles with corresponding pushers in Working Position will knit.

– **Row counter on zero.**

– **At left –6 × 1 • 2. R**

Knit two rows

At left transfer the end stitch of the right half to the adjacent needle at right.

Empty needle and corresponding pusher out of Working Position.

Repeat five times.

Now the row counter reads 12.

## Section E = shoulder shaping

Basically, you can proceed as for the second test piece. But, since the pushers are already in Working Position, you can use these to shape the shoulder. At the same time continue shaping the neck at left.

– **Row counter on zero**

Lock unchanged

– **At left –5 × 1 • 2. R.**

– **At right ▲ – 6 × 9 • 2. R ▲**

The sign ▲ indicates that six times nine stitches are decreased every alternate row using graduations, as follows:

– **Lock at right**

– **At left neck edge decrease one stitch**

Empty needle and corresponding pusher out of Working Position.

– **Knit one row = lock at left**

– **At right put nine pushers into Rest Position**

– **Knit one row**

Continue in the same way, i. e.

with lock at right = at left decrease one stitch;

with lock at left = at right put nine pushers into Rest Position.

– **Knit nine rows = lock at left**

At right bring all the pushers corresponding to needles holding a stitch into Working Position.

– **Knit one row**

– **Cast off** as for the second test piece.

Finally, break off yarn, put it between the two beds and fix it in the slot at the side.

## Section F = second shoulder

– **Lock N**

– **Row counter on zero**

– **Knit one row**

– **At right neck edge decrease one stitch**

– **Knit 11 rows**, decreasing one stitch at right hand side every alternate row.

## Section G = 2nd shoulder shaping

In order to proceed in the same manner as for the right shoulder, bring for each needle in Working Position one pusher into Working Position.

– **Lock BX**

– **Lock at right = at left put nine pushers into Rest Position. Knit one row**

– **Lock at left = at right decrease one stitch**

– **Repeat until six decreases and graduated rows are completed as right hand shoulder.**

– **Cast off**

You have now completed the front part of a sweater with round neck. Press the test pieces (page 80), and join the side and shoulder seams, leaving an opening of approx. 4 cm (1½ inches) on each shoulder. Work one row of single crochet round the neck opening, and crochet a cord at each end to be used as bows at the neck.



## 4th test piece = graduations (short rows)

Child's skirt: to fit child 98 cm (38½ inches) tall. The beginning of the knitting will be joined into a seam later on. You will achieve a much better effect if you begin with a few rows in contrast yarn, which will be unravelled again when making up the seam.

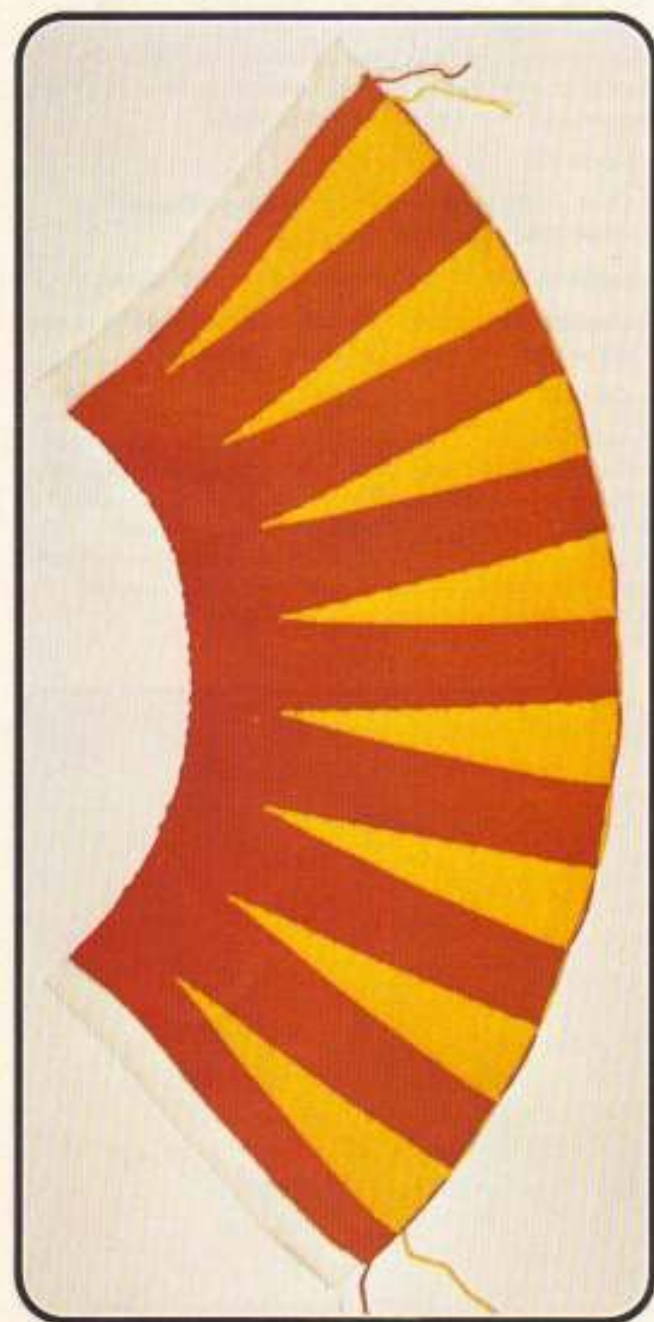

### Cast-on in stocking stitch with contrast yarn



On front bed over a width of 90 needles bring every alternate needle into Working Position, i. e. 45 needles

- Lock  $\frac{GX}{N}$
- Black strippers
- Stitch size 1
- Knit one row



- Second half of needles in Working Position
- Stitch size 5¼
- Knit one row

You have now completed the cast-on.



On the back bed put into Working Position the five needles opposite the last five needles at right on the front bed.

- Lock at back CX
- Racking handle down
- Stitch size at back 3¾

The setting on the back lock will remain unchanged for the whole of the skirt.

Now this will automatically knit a hem for your skirt.

Change the contrast yarn for the main yarn after about ten rows.

- Row counter on zero
- Knit ten rows

## Graduations

- Row counter on zero
- Change colour
- Front lock BX
- For each needle in Working Position put one pusher into Working Position on front bed
- At left put the first 20 pushers into Rest Position
- From the left ▲–13×5•2.R▲ as follows:
- Knit two rows  
Starting from the left bring the first five pushers into Rest Position. Knit 26 rows, and every time the lock is at right bring at left five more pushers into Rest Position.

## Knitting stocking stitch

- Change colour
- Row counter on zero
- Front lock N
- All pushers in Rest Position
- Knit 26 rows

To make your test piece into a child's skirt, repeat the graduations seven times more, as well as the 26 rows in stocking stitch, but on the eighth time knit only 16 rows of stocking stitch. Change colour, and knit a further 10 rows with contrast yarn. These 10 rows will be unraveled when you are joining the seam.

Finally, release the stitches as explained on page 16.

For blocking and pressing see page 80.

For grafting together the side seams see page 81.





## 5th test piece = knitting tubular and half tubular

Child's hat. Of all the basic stitch patterns only knitting tubular and half tubular now remain to be learned.



## Tubular, open cast-on

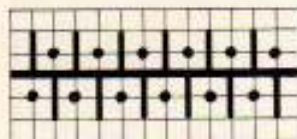

On both beds over a width of 50 needles put every alternate needle into Working Position in such a way, that every needle in Working Position faces a needle out of Working Position.

**Important: Do not follow the needle rule, i. e. last needle at left = on back bed last needle at right = on front bed**

- Racking handle up
- Black strippers
- Lock  $\frac{CX}{CX}$
- Stitch size 1
- Knit two rows

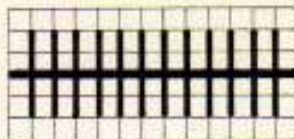

- On front and back bed put the second half of the needles into Working Position.

- **Stitch size 5¼**

Knit two rows slowly and carefully.

Continue knitting until the row counter reads 50.

As you are knitting tubular, i. e. from right to left on the front bed, and from left to right on the back bed, you will in fact only have knitted 25 rows, although your row counter will be showing 50.

To avoid any misunderstandings, we always say in such a case: **knit RC 50** (RC = Row Counter).

## Half tubular

- Row counter on zero

- Lock  $\frac{BX}{BX}$  →

The arrow pointing right means press the right arrow keys on the two locks.

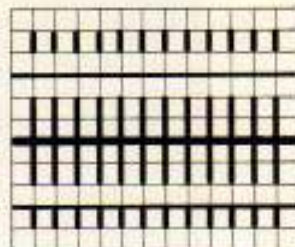

- **For every needle in work at back and front, remove corresponding pusher from blocking rail.**

Arrange them acc. to the diagram, i. e. on front bed in Working Position, on back bed in Rest Position. The knitted piece is open on the right side and closed on the left side.

With this method you can knit pieces in stocking stitch twice the width of the machine.

- **Knit RC 200**

- **Cast off** as explained on page 27.

All you have to do now to complete the hat, is to carefully draw up the loose length of yarn on the cast-on edge and to fasten it off securely.

## 6th test piece = fancy stitches

### Children's bag

To become familiar with the automatic pattern device of your DUOMATIC 80, we will now try out some of our most attractive fancy stitches. This test piece can be made into a bag.

We have only chosen a few examples. A larger selection is shown on page 64, as well as in our stitch pattern books.



## Tubular cast-on

with all needles

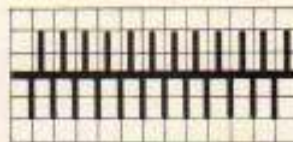

- 100 needles in Working Position  
(50 on back bed, 50 on front bed)

Observe needle rule

- Racking handle down

- Orange strippers

- One row stitch size 1,

lock  $\frac{N}{N}$

- Two rows stitch size 3½,

lock  $\frac{CX}{CX}$

- One row stitch size 4½,

lock  $\frac{N}{N}$

### 1. Overknit

A fabric with a texture particularly suitable for garments which must keep their shape, for example, skirts and coats.

### Handle down, orange strippers

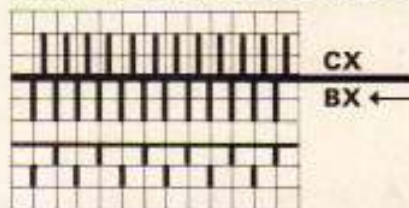

Arrange needles and pushers acc. to diagram.

Knit 40 rows

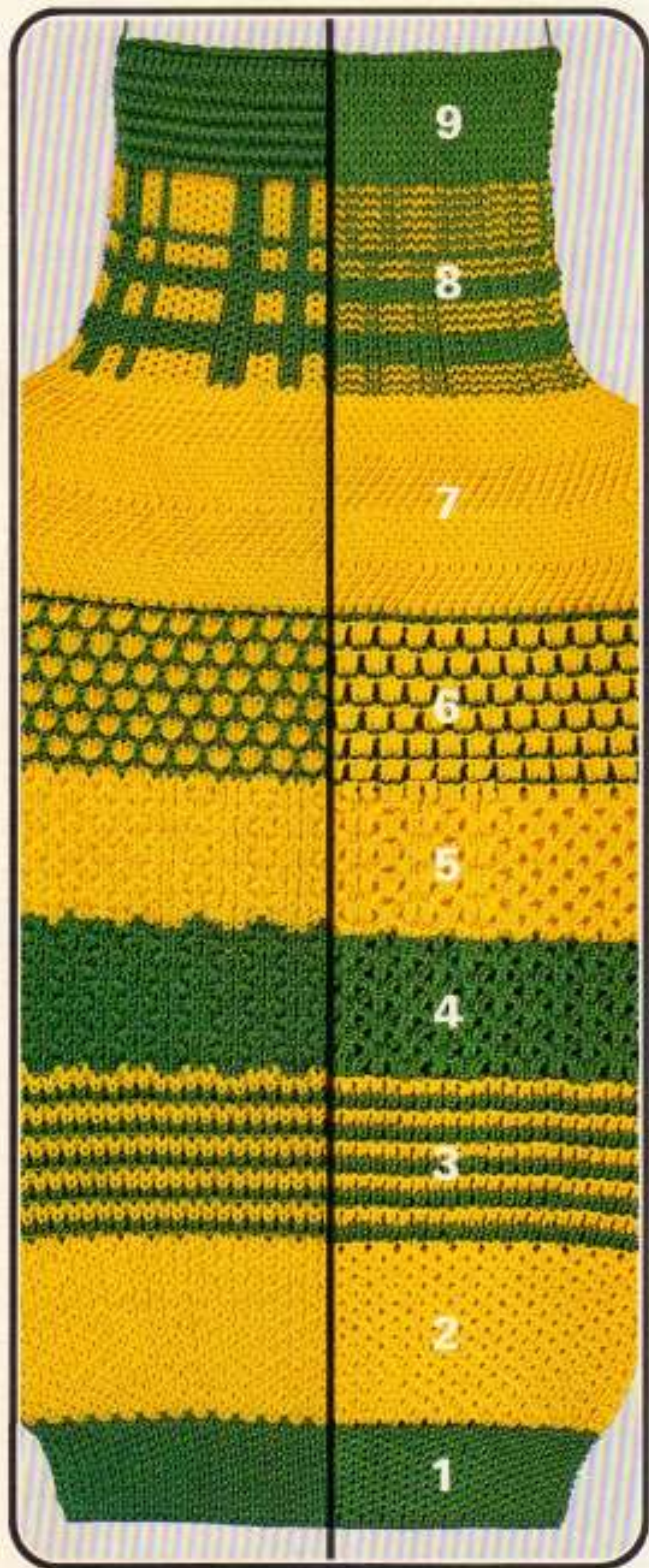

**2. Honeycomb pattern (simple)**

Recommended for sports wear.

Handle down, orange strippers

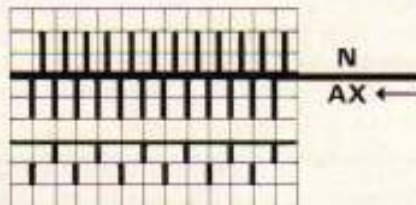

Needle and pusher arrangement unchanged from pattern 1.  
Change colour.

**Knit 40 rows**

**3. Raised pattern**

Handle down, orange strippers

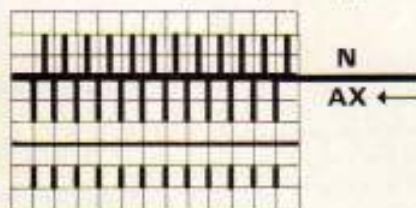

Change pusher arrangement acc. to diagram.

**Knit 42 rows, changing colour every fourth row.**

**4. Honeycomb pattern (double)**

Handle down, orange strippers

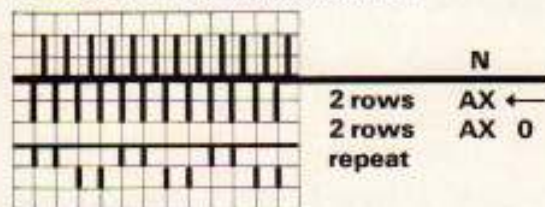

Knit 2 rows with left arrow key at front  
Knit 2 rows with centre key (0) at front

**Knit a total of 40 rows**

### 5. An Arran effect

By proceeding in the same manner as for pattern 4, you can knit several fancy stitches on the same row simultaneously.

#### Handle down, orange strippers

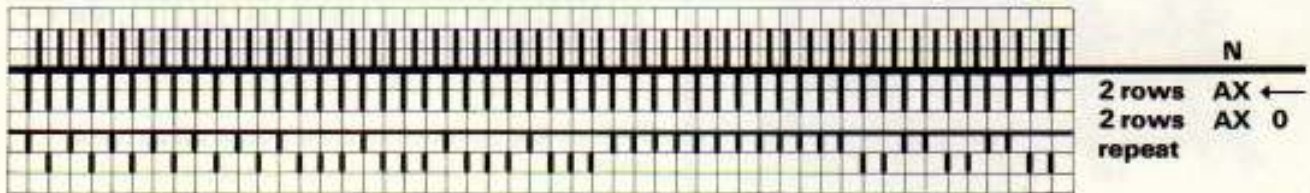

Arrange pushers acc. to diagram  
Change colour

**Knit 40 rows**

### 6. Reversible pattern in two colours

Either side of this pattern can be used.

#### Handle down, orange strippers

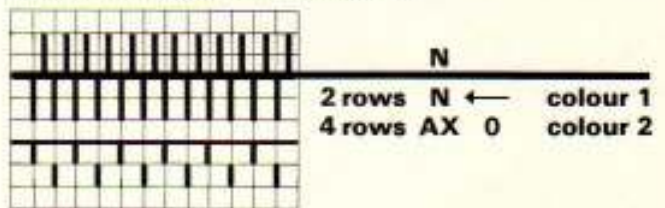

Repeat the first 6 rows

**Knit a total of 38 rows**

### 7. Racking pattern

#### Handle down, orange strippers

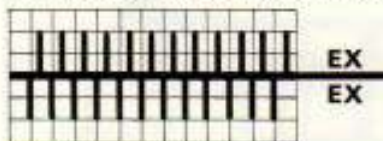

Pushers in Rest Position

Rack one full turn to the left

Knit one row

Rack one full turn to the right

Knit one row

Repeat the first two rows six times more = 14 rows

Knit one row without racking

Repeat the first fifteen rows three time more.



## 8. Fairisle without loops on the reverse side

Handle down, orange strippers

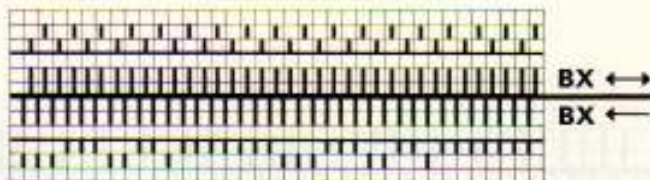

On front and back bed arrange pushers acc. to diagram.

Change colour as follows:

- |         |  |               |
|---------|--|---------------|
| 3 times |  | 2 rows green  |
|         |  | 2 rows yellow |
|         |  | 12 rows green |
| 3 times |  | 2 rows green  |
|         |  | 2 rows yellow |
|         |  | 8 rows green  |
| twice   |  | 2 rows green  |
|         |  | 2 rows yellow |
|         |  | 4 rows green  |
| 6 times |  | 2 rows green  |
|         |  | 2 rows yellow |

### Knit RC 80

**Important:** Remember that when your row counter shows 4 rows, only 2 rows have actually been knitted, since you are first knitting the stitches of the one colour, and then those of the other colour.



## 9. Tuck pattern

Handle down, black strippers

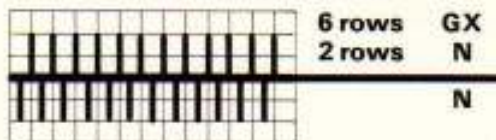

### Insert black strippers

Repeat the first 8 rows five times

### Knit 48 rows

**Cast off**, as described for 1st test piece, pages 22, 23.

By joining the sides, you can make your test piece into an amusing hand bag for children.

To wear it as a shoulder bag, simply knit three straps (tubular) over six needles, measuring approx. 1 metre (39 inches), and plait them as shown in the picture.

# Basic stitch patterns

## Stocking stitch, single-bed

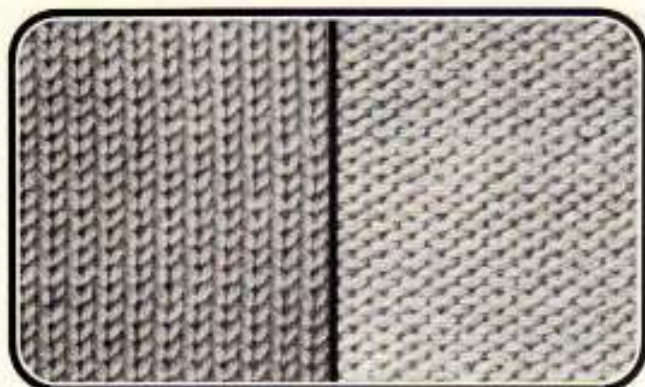

Right side

Reverse side

### Black strippers



Knitted on all needles on one bed.  
Stocking stitch has a right side and a reverse side.

## Knit/Knit = K/K, double-bed



### Orange strippers, handle down

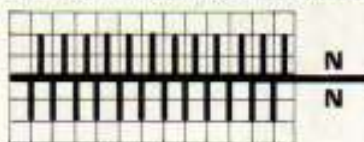

Knitted on all needles on both beds. Knit/Knit looks the same on both sides. Not recommended for borders on stocking stitch garments.

## 1:1 rib, double-bed

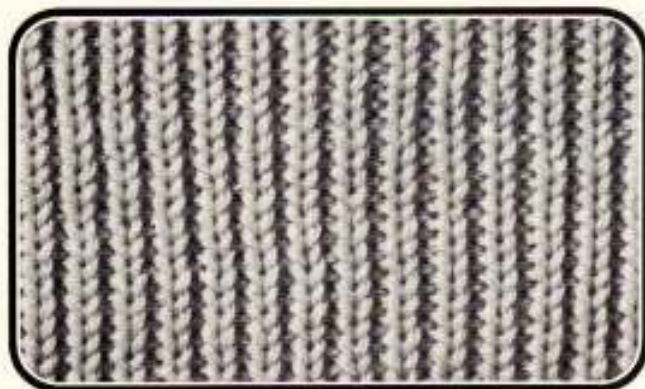

### Orange strippers, handle up

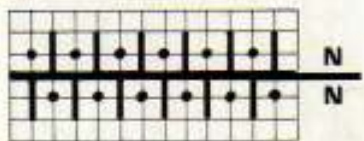

Knitted on every alternate needle on both beds.  
1:1 rib looks the same on both sides, but is slightly more elastic than K/K and, therefore, more suitable for borders on sweaters.

# Basic stitch patterns

## 2:2 rib, double-bed

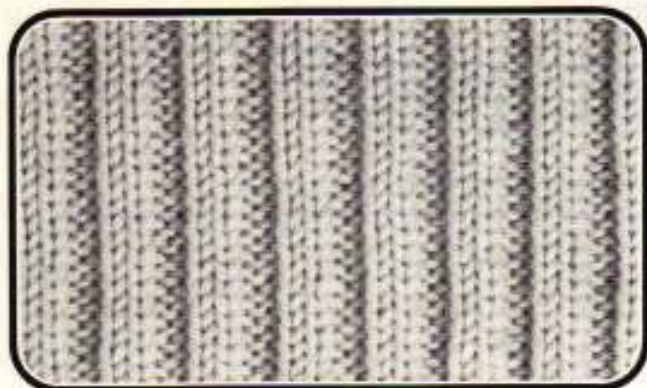

### Orange strippers, handle down

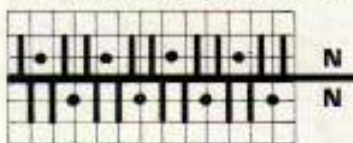

For 2:2 rib every 3rd needle on front and back bed remains out of work. The knitting looks the same on both sides. It is very elastic and, therefore, particularly suitable for borders.

## Fisherman's rib, double-bed



### Orange strippers, handle down

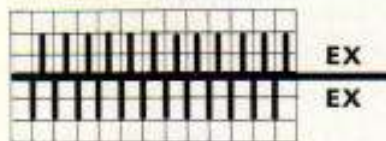

Knitted with all needles on both beds. Fisherman's rib looks the same on both sides.

## Half Fisherman's rib, double-bed

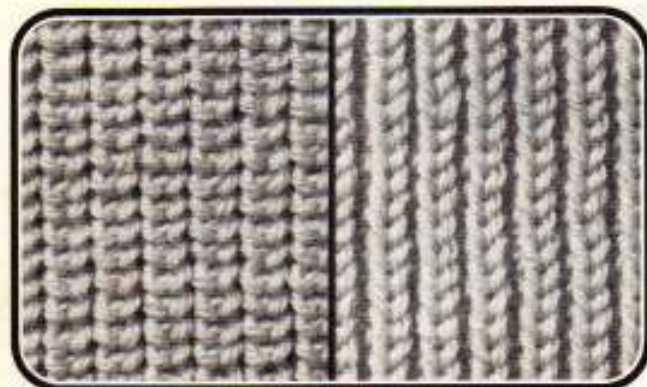

### Orange strippers, handle down

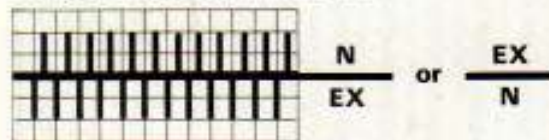

On the side where the lock is set at N, you get a pearl pattern; the other side looks like fisherman's rib.

# Basic stitch patterns

## Tubular



### Black strippers, handle up

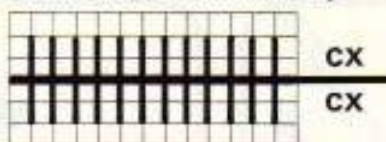

On front bed knit from right to left, on back bed from left to right.

## Half tubular, open at right

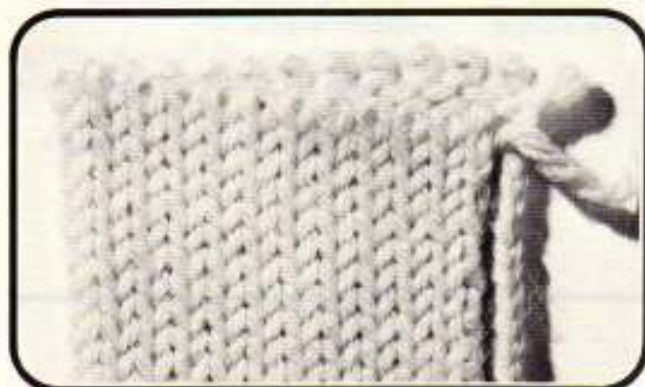

### Black strippers, handle up

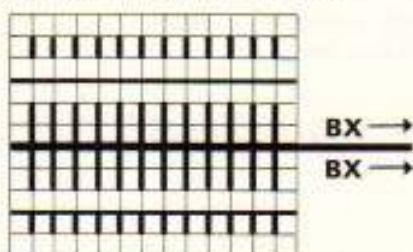

Needle and pusher arrangement acc. to diagram.

Half tubular knitting is open at right, thereby giving the possibility of obtaining a stocking stitch piece of knitting twice the width of the machine, which can be very useful for dresses and skirts.

For half tubular open at left, the two left arrow keys must be used; otherwise proceed as described above.

## Long stitch, double-bed

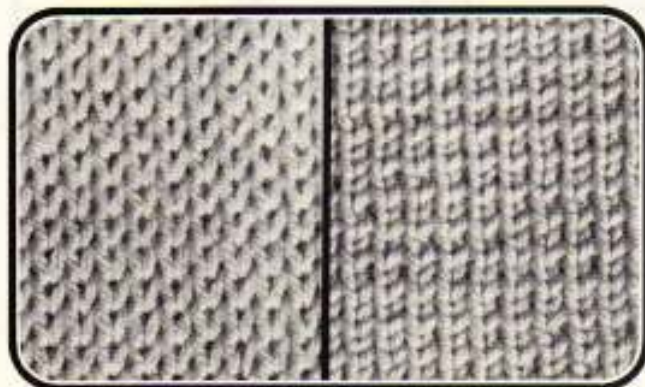

### Orange strippers, handle down

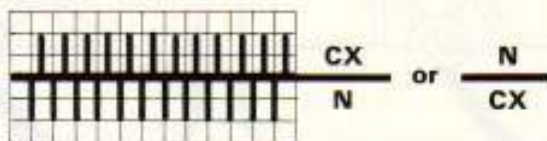

Long stitch is knitted with all needles on both beds. On the side where the lock is set at CX, the stitch becomes longer. This stitch is particularly suitable for garments which must keep their shape well.



# Transfer of stitches

## Transferring one stitch onto adjacent needle



Insert the eyelet of the orange tool into the needle head which holds the stitch to be transferred. Pull the needle upwards until the stitch lies behind the open latch.



Push the needle downwards until the stitch slips over the closed latch onto the shaft of the orange tool.

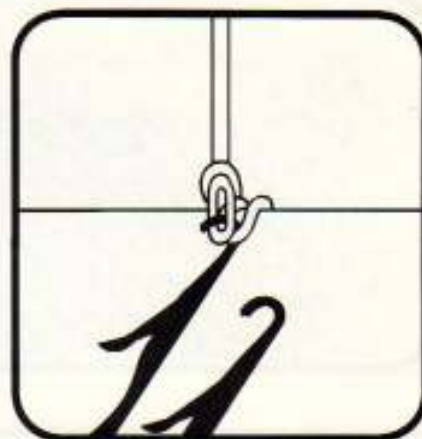

Unhook the orange tool and insert it onto the needle head of the adjacent needle. Tilt the orange tool forward until the stitch slips onto the new needle head. Put the empty needle out of work.

## Transferring stitches from rib to stocking stitch

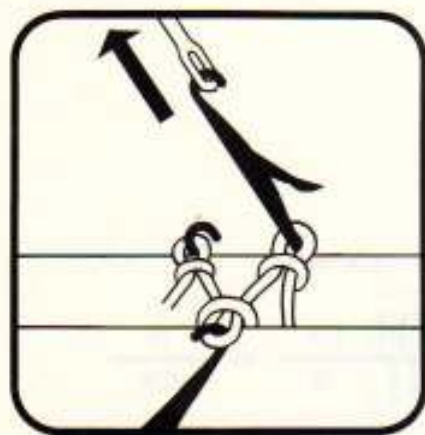

Insert one eyelet of the double end bodkin into the needle holding the stitch to be transferred. Pull the needle upwards until the stitch is behind the open latch.

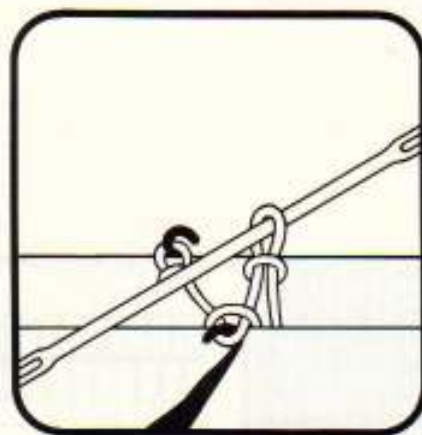

Push the needle downwards again until the stitch slips over the closed latch onto the double end bodkin. Unhook the bodkin, making the stitch slide to the other end.

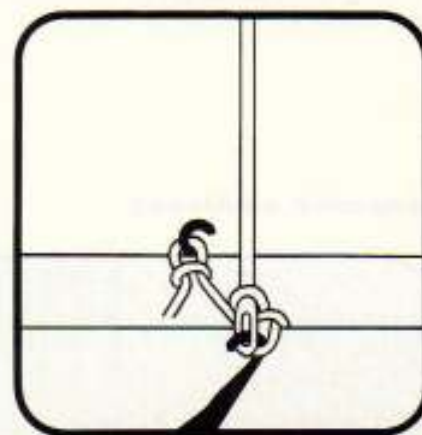

Insert the eyelet into the corresponding needle head on the front bed. Tilt the bodkin forward until the stitch slips onto the needle head. Empty needle at back out of work.

# Transfer of stitches

## Transferring stitches with the deckercomb



Remove rail from deckercomb. Insert eyelets into required number of needle heads, taking care to take hold of every single needle head. Pull needles upwards until the stitches are behind the open latches.

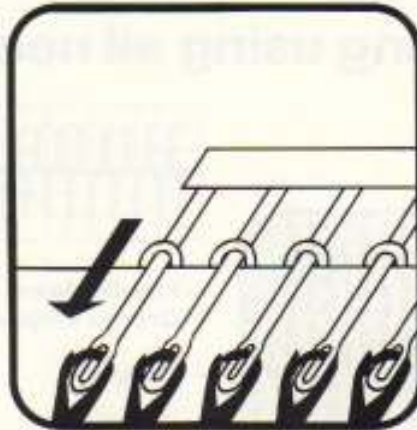

Push the needles downwards until the stitches slip over the closed latches onto the deckercomb. Unhook the deckercomb, and replace the decker rail if you do not immediately want to transfer the stitches.

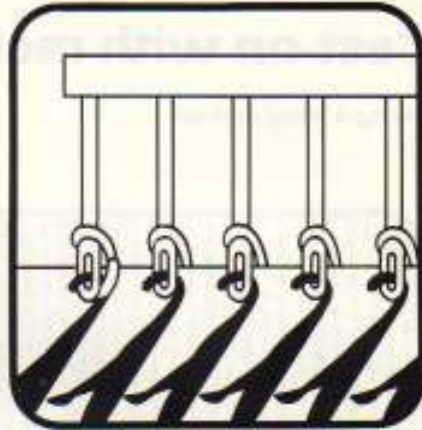

When inserting the eyelets into the new needle heads, be careful to take hold of all the heads. Now tilt deckercomb forward while slightly pulling down the knitting. Empty needles out of work.

# Cast on

## Double-bed

### Cast-on with racking using all needles

Giving a loose cast-on.

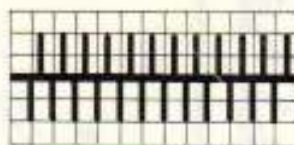

– All needles back and front in Working Position  
Observe needle rule

- Handle down
- Orange strippers
- Lock  $\frac{N}{N}$
- Same stitch size as for main knitting
- Racking handle one full turn to the left
- Knit 1 row
- Racking handle one full turn to the right
- Knit 1 row
- continue knitting.

---

## Tubular cast-on using all needles

This gives an excellent cast-on, ideal for borders.

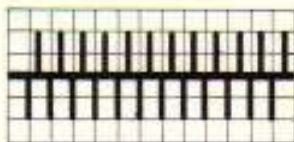

– All needles back and front in Working Position  
Observe needle rule

- Handle down
- Orange strippers
- Lock  $\frac{N}{N}$
- Stitch size  $1\frac{1}{2}$
- Knit 1 row
- Lock  $\frac{CX}{CX}$
- Set stitch size to approx.  $\frac{3}{4}$  of the stitch size used for the main knitting.
- Knit 2 rows
- Lock  $\frac{N}{N}$
- Stitch size as for main knitting
- Knit 1 row
- continue knitting.

## Tubular cast-on for 1:1 rib

For 1:1 rib we recommend the tubular cast-on.

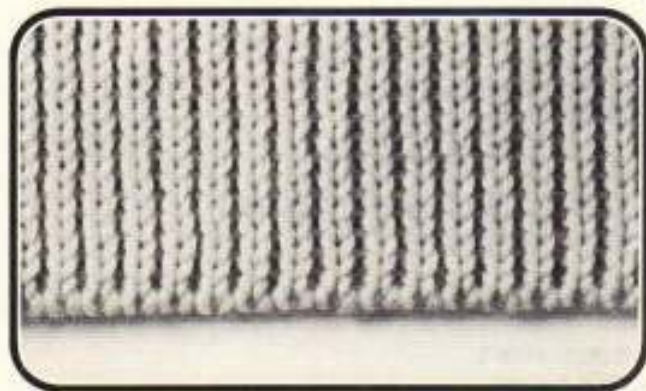

– Arrange needles acc. to diagram.  
Observe needle rule

- Handle up
- Orange strippers
- Lock  $\frac{N}{N}$
- Stitch size  $1\frac{1}{2}$
- Knit 1 row
- Lock  $\frac{CX}{CX}$
- Set stitch size to approx.  $\frac{3}{4}$  of the stitch size used for the main knitting.
- Knit 2 rows
- Lock  $\frac{N}{N}$
- Stitch size as for main knitting
- Knit 1 row  
continue knitting.

## Tubular cast-on for 2:2 rib

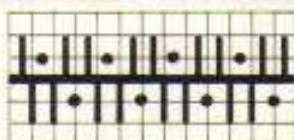

– Arrange needles acc. to diagram  
Observe needle rule

- Handle down
- Orange strippers
- Lock  $\frac{N}{N}$
- Stitch size  $1\frac{1}{2}$
- Handle one full turn to the left acc. to diagram
- Knit 1 row
- Lock  $\frac{CX}{CX}$
- Stitch size as for main knitting
- Knit 2 rows
- Handle one full turn to the right
- Lock  $\frac{N}{N}$
- Knit 1 row  
continue knitting.

## Single-bed

### Stocking stitch, simple cast-on

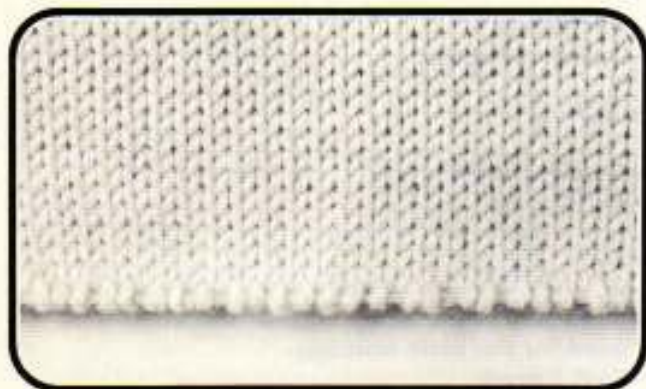

- Arrange needles acc. to diagram
  - Black strippers
  - Lock  $\frac{GX}{N}$
  - Stitch size 1
  - Knit 1 row
  - Put second half of the needles into Working Position.
  - Stitch size as for main knitting
  - Knit 1 row
- continue knitting.

### Cast-on in stocking stitch with pushers

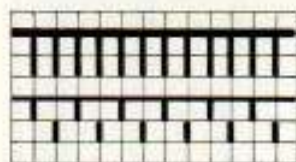
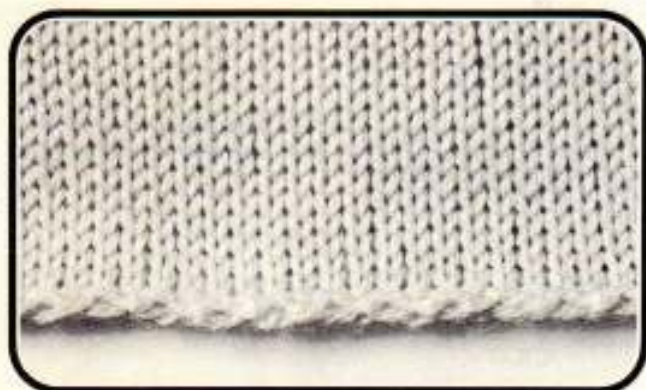

- Arrange needles and pushers acc. to diagram
  - Black strippers
  - Lock  $\frac{GX}{BX \leftrightarrow}$
  - Stitch size 1 number lower than for main knitting
  - Knit 4 rows
  - Stitch size as for main knitting
  - Lock  $\frac{GX}{N}$
- continue knitting.

## Tubular, closed cast-on

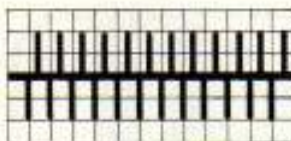
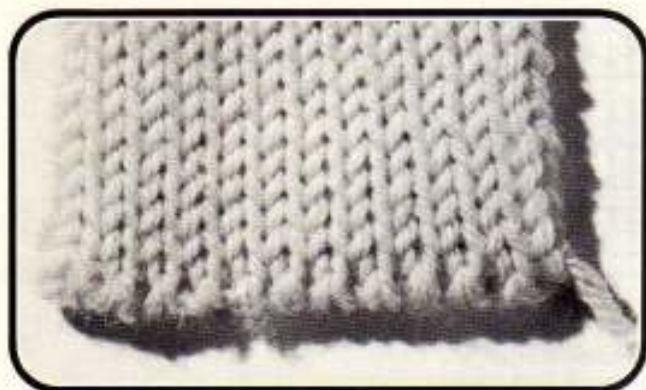

- Arrange needles acc. to diagram
- Handle down
- Black strippers
- Lock  $\frac{N}{N}$
- Stitch size  $2\frac{1}{2}$
- Knit 1 row
- Lock  $\frac{CX}{CX}$
- Set stitch size to approx.  $\frac{3}{4}$  of the stitch size used for the main knitting.
- Knit 2 rows
- Stitch size as for main knitting  
continue knitting tubular.

## Tubular, open cast-on

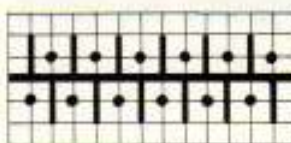

- Arrange needles acc. to diagram  
Division contrary to needle rule.
- Handle up
- Black strippers
- Lock  $\frac{CX}{CX}$
- Stitch size 1
- Knit 2 rows
- Put second half of needles into Working Position
- Stitch size as for main knitting  
continue knitting.

# Casting on

## Half tubular, open at right

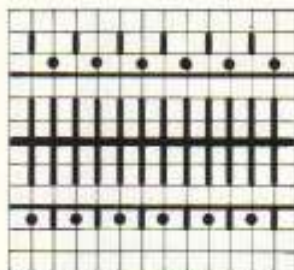
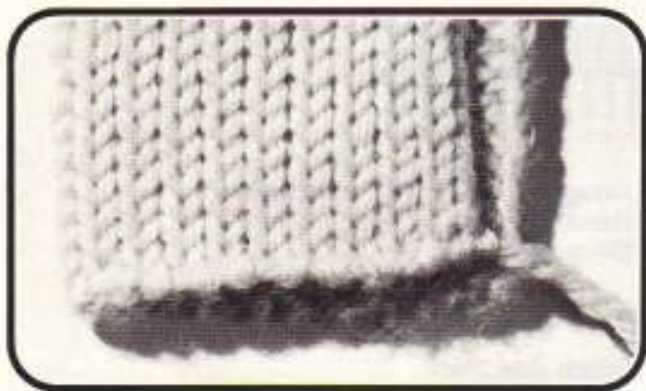

- Arrange needles and pushers acc. to diagram
- Handle up
- Black strippers
- Lock  $\frac{BX \rightarrow}{BX \rightarrow}$
- Stitch size 1
- Knit 2 rows
- Take second half of pushers out of blocking rail, and align them with the others (at front Rest Position, at back Working Position).
- Set stitch size to approx.  $\frac{3}{4}$  of the stitch size used for the main knitting.
- Knit 2 rows
- Stitch size as for main knitting  
continue knitting.

## Half tubular, open at left

Use same procedure as for "open at right", but with left arrow keys.

## Double-bed

### Casting off by transferring the stitches



This method results in a very neat finish, and can be used for all double-bed knitting.

- **Transfer all stitches from back to front bed**  
For ribbing it may be necessary to put empty needles into Working Position on the front bed in order to place the stitches from the back bed on them.
- **At back increase stitch size by 1 number.**  
(At back all needles in Working Position.)
- **Knit 1 row**
- **Lower front bed**  
Push the knitting towards the back bed to lengthen the stitches on the needles of the front bed.
- **Using the yellow tool crochet off the stitches which are on the needles of the front bed.**



Insert the open latch needle into the first stitch at right.



Then insert the yellow tool into the second stitch, moving it downwards until the first stitch slips behind the open latch.

**Important:** The second stitch must on no account slip behind the latch.



Now pull the yellow tool upwards until the first stitch slips over the closed latch.

Continue as described above by inserting the yellow tool into the following stitch.

**Finally break off yarn and pull it through the last stitch.**

For certain yarns which are not as elastic, for example cotton or rayon, or if a particularly loose cast-off is required, it may be necessary to increase the stitch size on the back bed by more than one number.



## Casting off without transfer of stitches

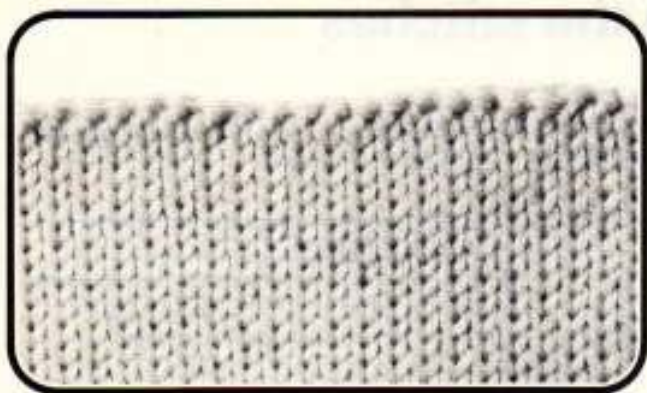

- Increase the stitch size up to double the size used for the main knitting.
- Knit the last row
- Lower front bed
- Using the yellow tool crochet off the stitches in zig-zag fashion as follows:



With the open latch needle pick up the last stitch at right back bed, then insert the yellow tool into the first stitch on front bed, moving downwards until the first stitch slips behind the latch. Pull yellow tool upwards until the first stitch slips over the closed latch. Now you have only one stitch on the needle, continue as described above by inserting the yellow tool into the next stitch on the back bed. Finally, break off yarn and draw it through the last stitch.

## Single-bed

### Casting off with the yellow tool



- For each needle in Working Position on front bed, put one needle into Working Position on back bed.
- Handle down
- Lock at back N
- Stitch size at back 1
- Knit 1 row
- Lower front bed
- With the yellow tool crochet off the stitches on the needles of the front bed, as described on page 47.

## Casting off by hand

This will result in a somewhat tighter edge than the one described above.

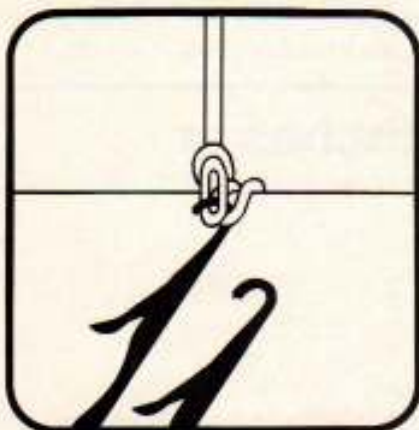

- Place the first stitch at right onto the adjacent needle at left.
- Pull this needle upwards until the two stitches slip behind the latch.



- Wind the yarn which was used for knitting twice round the needle in such a way that the thread once lies at the front and once at the back of the latch.



- Push the needle downwards until the two stitches slip over the closed latch and the yarn to form a new stitch.
- Continue pulling the needle downwards to make the new stitch slightly larger than the adjacent stitches. The more you enlarge the new stitch, the looser the cast-off.

Now place the new stitch onto the adjacent needle at left, and continue as already described.

- Put the empty needles out of work.

## Increasing one stitch at the edge of the knitting



– On the side where the lock is bring one empty needle into Working Position.

Continue knitting.

**For double-bed knitting** proceed in the same way, bringing one empty needle on back bed and one empty needle on front bed into Working Position. This equals an increase of two stitches.

## Fashion increasing – one to three stitches in from the edge of the knitting

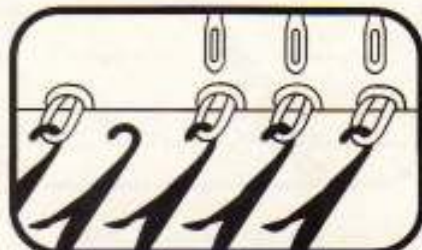

– At the edge of the knitting bring one empty needle into Working Position.

– Using the triple decker tool move the three end stitches one needle out.



– Place the purl stitch loop of the adjacent stitch at left onto the empty needle acc. to illustration.

Continue knitting.

This increase may be worked on the side where the lock is, as well as on the opposite side.

The procedure remains the same.

## Increasing one stitch at the centre of the knitting



- **Mark the needle from which you want to start your increases** (e. g. the 20th needle).

Mark the needle as follows:

If you knit without pushers (e. g. in stocking stitch), put one pusher into Rest Position under the needle serving as a marker. If you knit a pattern using pushers, mark the appropriate pusher foot with a drop of nail varnish.

- **At the edge of the knitting put one needle into Working Position.**
  - **Place all the stitches between the marked needle and the edge onto the dekercomb, and move them one needle out.**
  - **Onto the now empty needle place the loop of the adjacent stitch.**
- With this method you move one additional stitch out, every increase. These increases are used for example for bust darts.

## Increasing several stitches at the same time in double-bed knitting

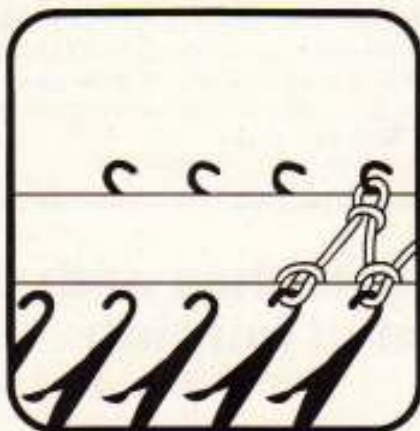

- **On the side opposite the lock bring the required number of needles into Working Position at back and front.**
- Continue knitting.

This method is suitable only for 1:1 rib or K/K knitting or any other needle division which ensures that after a knitted row the yarn will extend in zig-zag fashion between the two beds.

If the lock is set other than to N, leave the last two needles to be brought into Working Position on the lock side, after having knitted the first row.

## Increasing several stitches at the same time in single-bed knitting

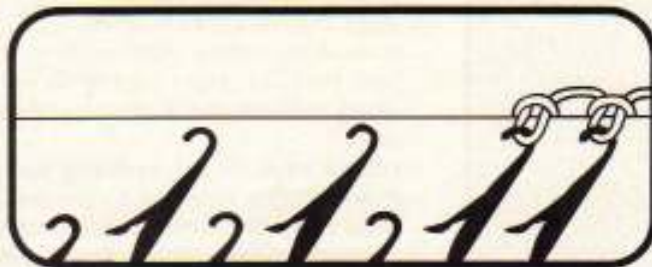

- On the side opposite the lock bring every alternate needle into Working Position (= half the required needles)
- Knit one row



- On the side where the lock is, push up the second half of the needles.

**Note:** From the very beginning make sure that the edge needle is being pushed up into Working Position together with the second group of needles, i. e. for an even number, begin with the first needle out from the edge, for an odd number start with the second needle out.

- Knit one row

## Increasing several stitches with the aid of a contrasting piece of knitting

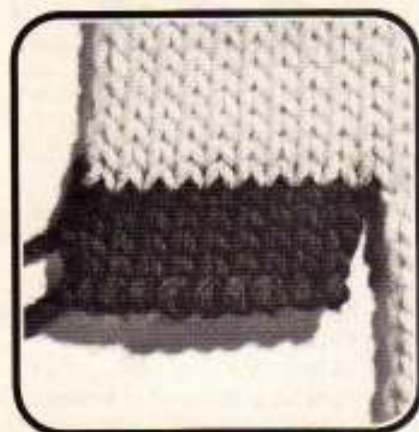

This method is recommended for edges which have to form a very neat seam (e. g. in kimono sleeves).

- **Take a contrasting piece of knitting** you no longer need, like an old test square, and unravel a few rows.
- **Using the orange tool, place as many loose stitches from the old test square as you want to increase onto the needles of the machine.**

Continue knitting.

This procedure is possible only on the side opposite the lock.

When making up the garment, unravel the rows of contrasting material, and join the loose stitches.

## Decreasing one stitch at the edge of the knitting



- Using the orange tool, transfer the edge stitch onto the adjacent needle.
- Put empty needle out of work.  
Continue knitting.

This procedure is possible on the side where the lock is as well as on the opposite side.

- For double-bed knitting proceed in the same way by transferring the edge stitch to the needle next to it on the front and back bed simultaneously.

## Decreasing one to three stitches in from the edge of the knitting



- Take the last three stitches onto the triple decker tool, and move them one needle in (i. e. so that there are two stitches on the third needle).
- Put the empty needle out of work.  
Continue knitting.  
This procedure is possible on the side where the lock is as well as on the opposite side.

## Decreasing one stitch at the centre in single-bed knitting



- Using the deckercomb, move the required number of stitches one needle in.
- Put empty needle out of work.

For these decreases always move the same number of stitches in.

This procedure is possible on the side where the lock is as well as on the opposite side.

Use this method of decreasing for skirts, as it gives a far better shape than using side decreases.

# Decreasing

## Decreasing several stitches in single-bed knitting

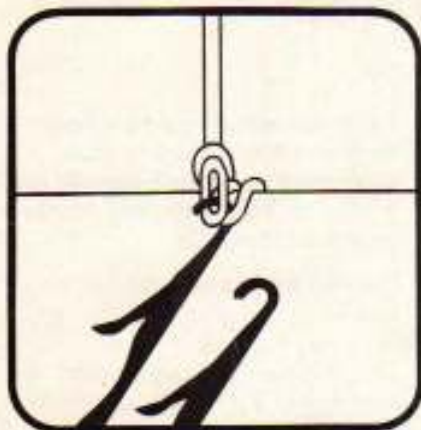
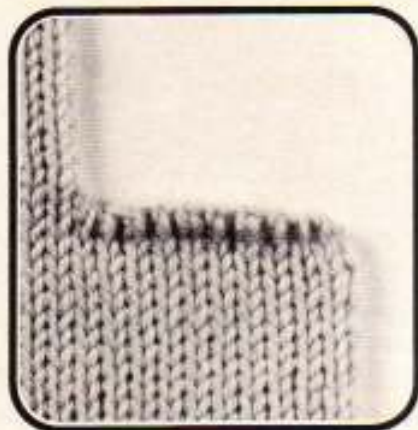

- **Transfer the first stitch on the side where the lock is onto the adjacent needle.**
- **Pull this needle upwards** until both stitches lie behind the latch.



- **Wind the yarn with which you are knitting twice round the needle**, so that it once lies at the back and once at the front of the latch.



- **Pull the needle downwards** until the original stitch and the yarn slip over the closed latch to form a new stitch.
- **Place the newly formed stitch onto the next needle**, and continue in the same way. Put the empty needle out of work. This procedure is possible only on the side where the lock is.

---

## Decreasing several stitches in double-bed knitting

- **On the side where the lock is, and using the double end bodkin, transfer the required number of stitches from the back bed to the corresponding needles on the front bed.** Continue as given for decreasing in single-bed knitting.

Graduations (short rows) are always worked with the lock on BX and using pushers. The rule is: With BX, only the needles with pushers in Working Position will knit.

This rule can be applied in different ways:

## Decreasing from the right with graduations

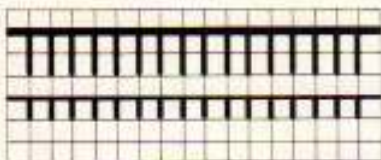

- For every needle in Working Position, bring the corresponding pusher into Working Position.
- Lock BX
- Knit one row (lock at left)

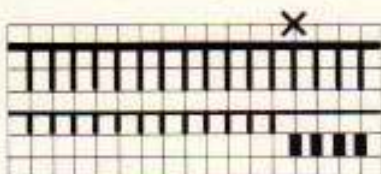

- At right put the first group of pushers into Rest Position.

The number of pushers required in Rest Position depends on the desired shape of the graduation (in our illustration there are four pushers).

- Knit two rows

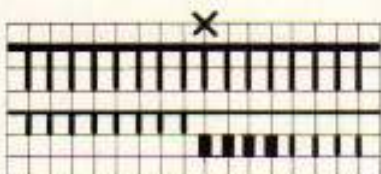

- At right put the next group of pushers into Rest Position, etc.

End with lock at left.

- Put all pushers into Rest Position
- Lock N

Continue knitting.  
Now all needles are knitting.

## Decreasing from the left with graduations

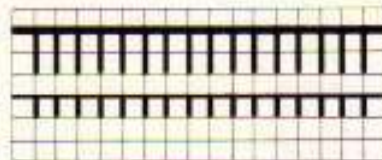
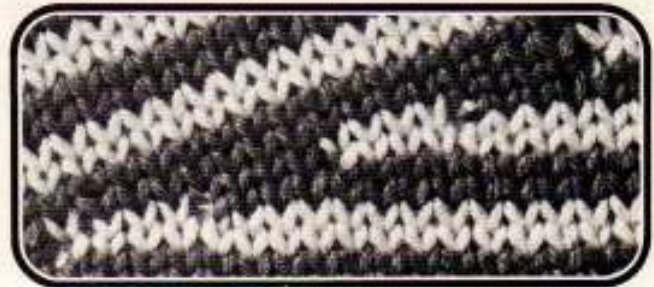

- For each needle in Working Position put the corresponding pusher into Working Position.
- Lock BX (lock at right)



- At left put the first group of pushers into Rest Position.

- Knit two rows.

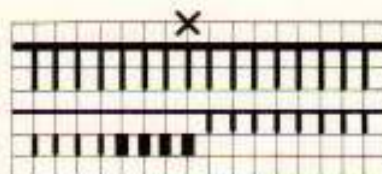

- At left put the next group of pushers into Rest Position, etc.

End with lock at right

- Put all pushers into Rest Position.
- Lock N

Continue knitting.  
Now all needles are knitting.



# Graduations

## Increasing from the left with graduations



– **Knit one row.** Lock at left.

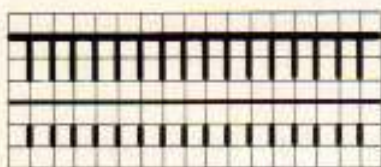

– For every needle in Working Position put the corresponding pusher into Rest Position.



– At left put the first group of pushers into Working Position.

– Knit two rows

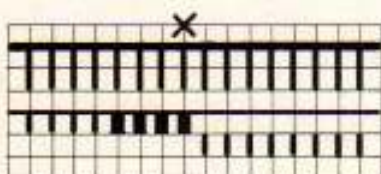

– Put the next group of pushers into Working Position, etc.

– Finally, put all pushers into Rest Position.

– **Lock N**  
Continue knitting.

## Increasing from the right with graduations



Lock at right



– For every needle in Working Position put the corresponding pusher into Rest Position.



– At right put the first group of pushers into Working Position.

– Knit two rows



– Put the next group of pushers into Working Position, etc.

– Finally, put all pushers into Rest Position.

– **Lock N**  
Continue knitting.

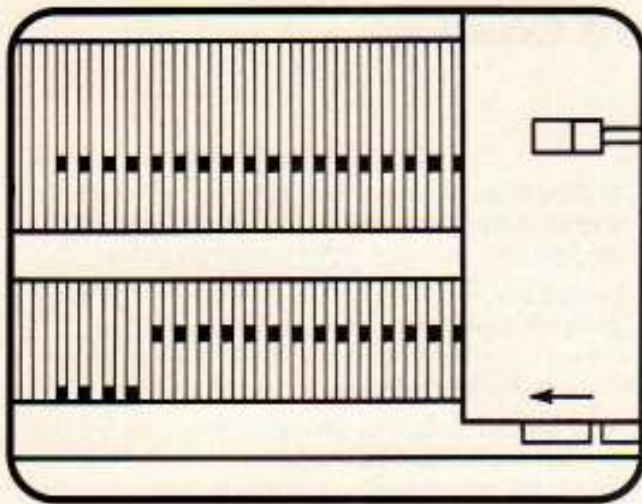

## Basic rule:

Always change the position of more than one pusher at the same time on the side opposite the lock.

## Abbreviation

Increasing or decreasing with graduations is always indicated by a  $\blacktriangle$ , for example  $\blacktriangle -8 \times 4 \bullet 2. R \blacktriangle$ , i.e. with graduations, decrease eight times four stitches every alternate row.

**If you wish to prevent small holes forming** along the graduations, proceed as follows: On the side where the lock is, wind the yarn round the needle which corresponds to the pusher last brought into Rest Position on the side opposite the lock. (Needles marked with a cross on our diagrams.)

## Bust darts = Decreasing with graduations from both ends

- Lock BX
- For every needle in Working Position put the corresponding pusher into Working Position.  
Lock at right
- At left put the first group of pushers into Rest Position.
- Knit one row
- At right put the first group of pushers into Rest Position.
- Knit one row, etc.  
End with the lock at right.
- At left put all pushers into Working Position.
- Knit one row
- At right put all pushers into Working Position.
- Knit one row
- Lock N  
Finally, put all pushers into Rest Position.  
Continue knitting.

## Knitting on same row in two colours diagonally

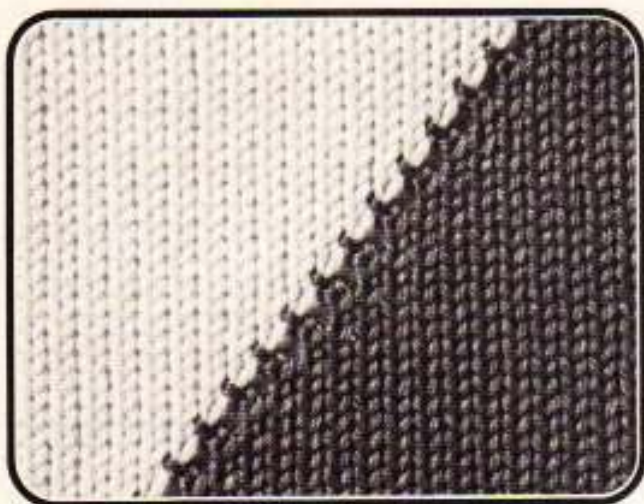

– Thread the colour for the right half of the knitting into the left feeding eyelet, the colour for the left half into the right feeding eyelet.

– Lock BX ←

Press left arrow key.

For each needle in Working Position take one pusher out of the blocking rail.

– First pusher at left in Working Position, all other pushers in Rest Position.

– Left feeding eyelet into the lock  
Knit two rows

– Change colour  
Knit two rows

– Second pusher at left in Working Position.

– Change colour  
Knit two rows

– Change colour  
Knit two rows

Continue in this way, i. e. changing colours every alternate row, at left putting an additional pusher into Working Position after every fourth row.

If you want to change the direction of the line separating the colours, then, on every fourth row put the last pusher of the left half into Rest Position.

It is possible to change the position of several pushers at the same time. The line dividing the colours will then be less pronounced.

## Intarsia

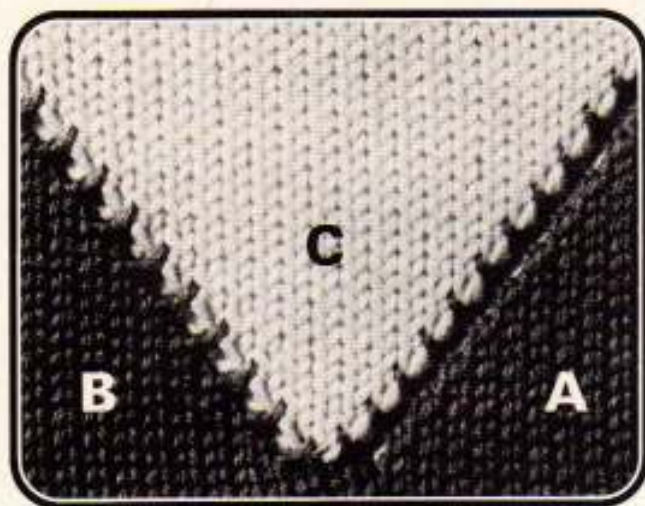

Start with a few rows in stocking stitch in one colour.

– **Lock BX**

For each needle in Working Position take a pusher out of the blocking rail.

**Section A**

– **Put right half of pushers into Working Position.**

– **Knit one row**

Lock at left

– **Of the pushers in Working Position, bring the last one at left into Rest Position.**

– **Knit two rows**

Continue as follows: Each time the lock is on the **left** side, bring the last pusher at **left** into Rest Position, until no pusher remains in Working Position. Break off yarn.

**Section B**

Lock at right, continue knitting with colour 1.

– **Put left half of pushers into Working Position.**

– **Knit two rows**

Lock at right

– **Of the pushers in Working Position bring the last one at right into Rest Position.**

– **Knit two rows.**

Continue as follows: Each time the lock is on the **right** side, bring the last pusher at **right** into Rest Position, until no pusher remains in Working Position.

Break off yarn.

**Section C**

– **Change colour**

Lock at right

– **Bring the first pusher at right of centre into Working Position.**

– **Knit one row**

– **Bring the first pusher at left of centre into Working Position.**

– **Knit one row**

Continue as follows: Each time the lock is on the **right** side, put an additional pusher into Working Position at **right**.

Proceed in the same way on the left side. Finally, when all pushers are in Working Position:

– **Set lock at N**

Put pushers into Rest Position.

Continue knitting.

# Necklines

To divide the stitches as required for shaping necklines, it is necessary to use the strippers and the BX-setting on the lock. There are three possible methods:

1. By knitting both halves at the same time.
2. By knitting first one half and then the other half, using pushers.
3. By placing the stitches of the second half onto deckercombs, while knitting the first half.

## 1. Knitting both halves of the neckline at the same time

This method is only advisable for vertical slits or pointed necklines worked in stocking stitch.

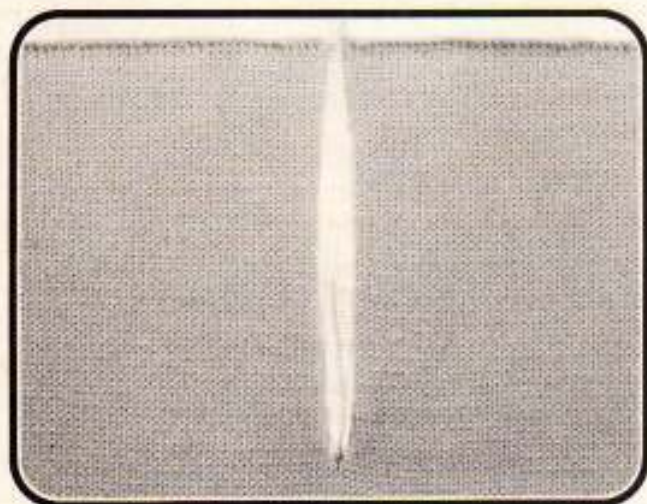

### Example: Vertical slit

- Lock BX ←
- Yarn for **right** half in the **left** feeding eyelet
- Yarn for **left** half in the **right** feeding eyelet
- Put pushers for right half into Rest Position
- Put pushers for left half into Working Position
- Left feeding eyelet into the lock
- Knit two rows  
(2 rows of the right half are being knitted)
- Change feeding eyelet
- Knit two rows  
(2 rows of the left half are being knitted)

**Note:** Don't forget that the row counter will be showing twice the number of rows than have actually been knitted, for you have knitted two rows of the first half, and then two rows of the second half. If you want to knit a pointed neckline (V-neck), decrease along the appropriate edges.

## 2. Knitting first one half, then the other half, using pushers

This method is suitable only for stocking stitch or fairisle work. However, it can be used for every type of neckline.

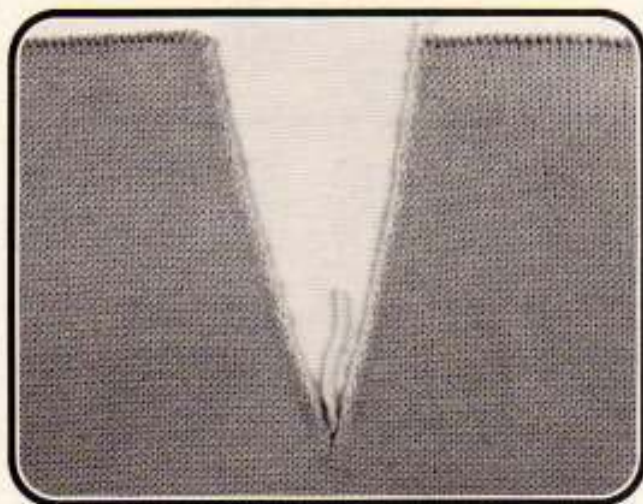

### Example: V-neck

- For the right half of the work put pushers into Working Position.
- Lock BX
- Knit the first half, decreasing at left for neck opening.  
Put the empty needles and pushers into Rest Position. (Our example –1•4. R)  
(Remember to shape the armhole at right at the same time)  
Cast off stitches.  
Break off yarn.
- Put the pushers for the right half into blocking rail.
- To knit the left half set lock to N.  
Knit the left half with reversed shapings, i. e. by decreasing on the right side for neck opening.  
Cast off.

## 3. Placing the stitches of the second half onto deckercombs, while knitting the first half

This is the simplest method when knitting patterns, as well as being suitable for all types of necklines.

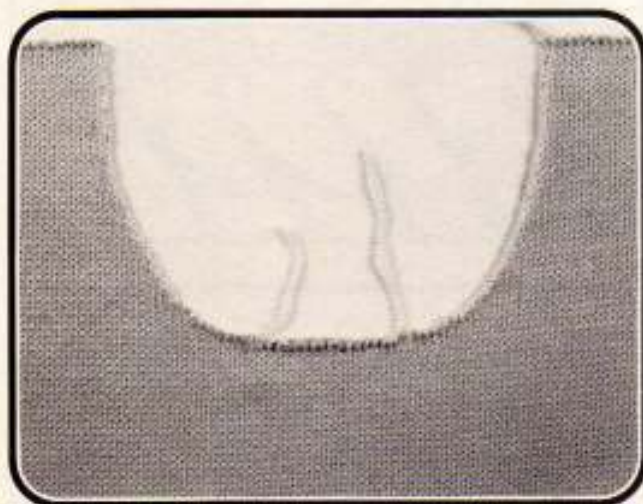

### Example: Round neck

- For the centre of the neck cast off the centre stitches as follows:  
(our example, 20 stitches)  
Take a length of yarn as used for the main knitting.  
Cast off the necessary number of stitches, as explained on page 49 for casting off by hand in stocking stitch.  
Finally, pull down the two ends of the yarn between the needle beds so they will be out of the way.
- Place the stitches at the left of the cast-off section onto deckercombs.  
Place decker rail over deckercomb.
- At right continue knitting.  
(If you have been knitting in pattern, make a note of where you are.)  
Decrease at left.  
(our example –5, –4, –3, –2×1•2. R)  
Knit the required number of rows (42)  
Cast off.
- Transfer the stitches back from the deckercombs to the needles of the machine.  
Knit the left side with reversed shapings, i. e. by decreasing at right.  
When you have finished, cast off.

# Buttonhole

## Buttonhole in double-bed knitting

In the majority of cases it is advisable to work buttonhole bands in double-bed knitting, like K/K or Long stitch.

Our buttonhole is 8 stitches across.

– Transfer 4 stitches from front to back bed.

– Knit these stitches together with those on the needles of the back bed.

This means, push up the needle until the first stitch slides behind the open latch, **but not the second one.**

Now pull the needle down until the first stitch slides over the closed latch. Only one stitch now remains in the needle head.

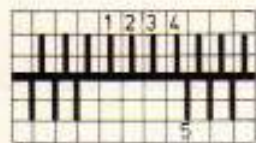

– Transfer stitch no 2 to needle no 1, and knit the two stitches together, as above.

– Now return the stitch to needle no 2.

– Transfer stitch no 3 to needle no 2, knit the two stitches together, and so forth.

– Finally, transfer the last stitch of the buttonhole to needle no 5 on the front bed.

– Leave all empty needles in Working Position.

– Knit one row.

– Twist zig-zag thread on the 8 needles.

Continue knitting.

There is no need to further neaten this buttonhole.

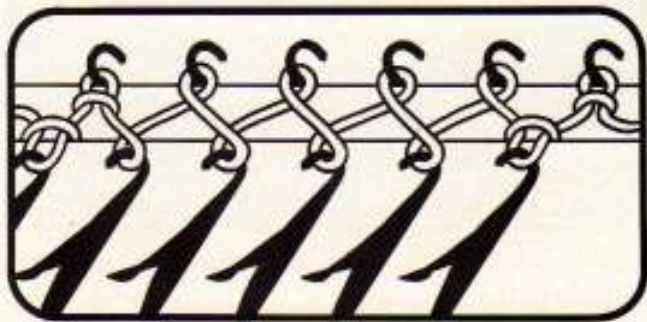
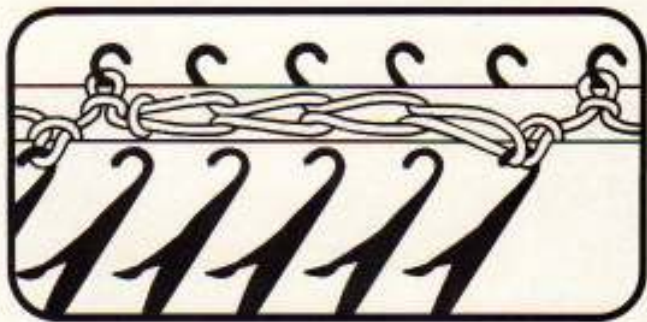
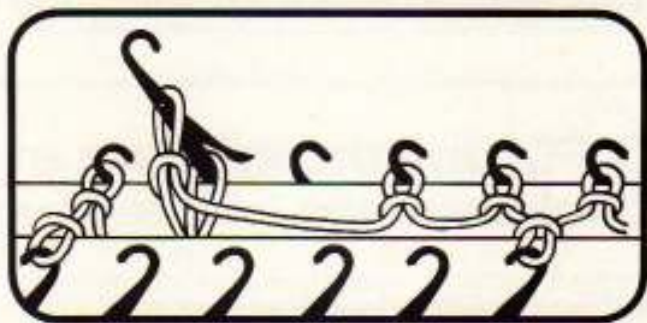
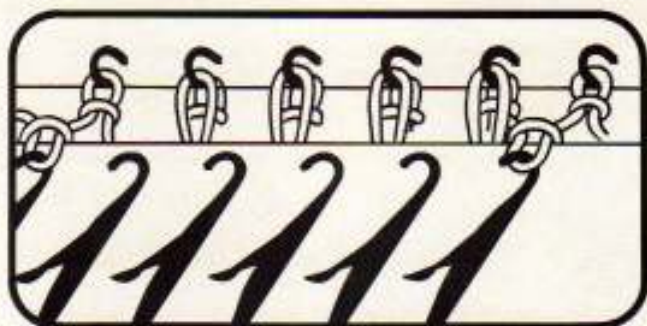

# Fancy stitch patterns

The different settings of the pattern selector dial make it possible to knit a great variety of patterns.

This page gives the various settings of the pattern selector dial.

The following pages show an extensive selection of fancy stitches using these settings.

<b>AX</b>	With pushers in Working Position = knits normally	With pushers in Rest Position = forms loops	
<b>BX</b>	With Pushers in Working Position = knits normally	With pushers in Rest Position = does not knit	
<b>CX</b>	Knits without pushers	Knits tubular, stocking stitch.	From right to left: knits on front bed  From left to right: knits on back bed
<b>DX</b>	With pushers in Working Position = knits tubular, stocking stitch	With pushers in Rest Position = tubular, with loops	From right to left: knits on front bed  From left to right: knits on back bed
<b>EX</b>	Knits without pushers	Knits Fisherman's rib	Both locks EX = Fisherman's rib  One lock EX, the other lock N = Half Fisherman's rib
<b>FX</b>	With pushers in Working Position = knits normally	With pushers in Rest Position = knits Fisherman's rib	
<b>GX</b>	Free move i. e. needles do not knit		
<b>HX</b>	With pushers in Working Position = knits tubular, stocking stitch	With pushers in Rest Position = does not knit	

The above information is also set out in abbreviated form on the diagram on the lock.



# Fancy stitch patterns

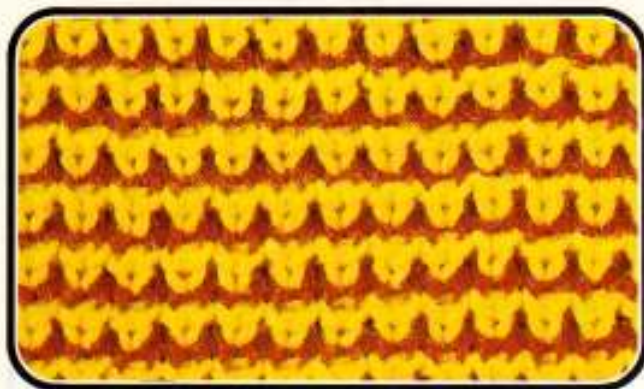

Handle down, orange strippers

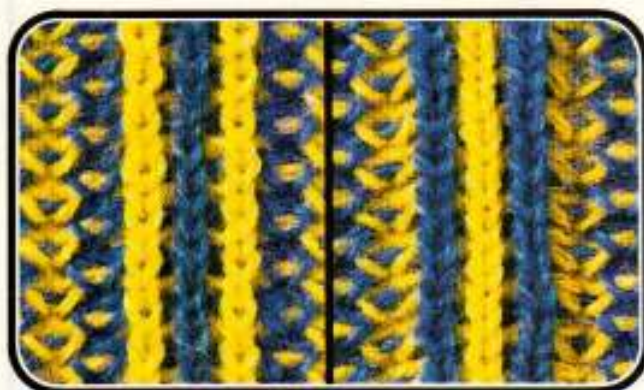
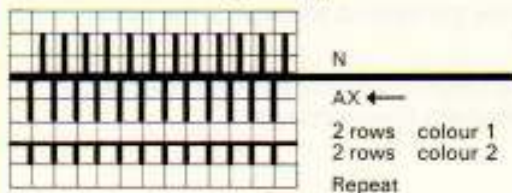

Handle up, black strippers

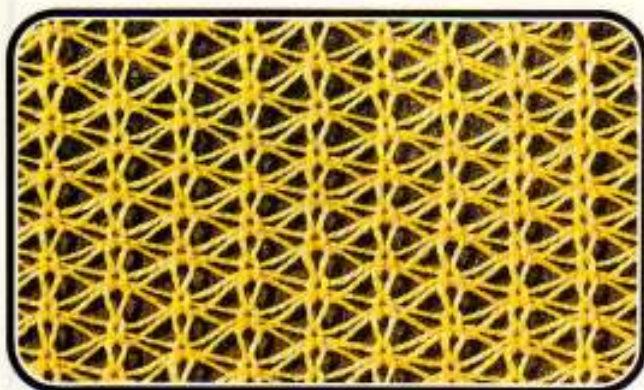
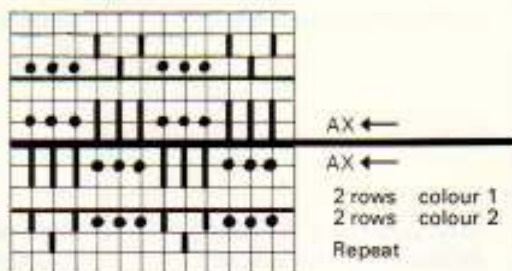

Handle down, black strippers

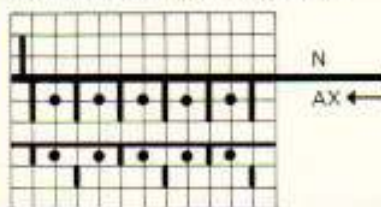

For a really good, neat edge bring an additional needle into Working Position at left on back bed.

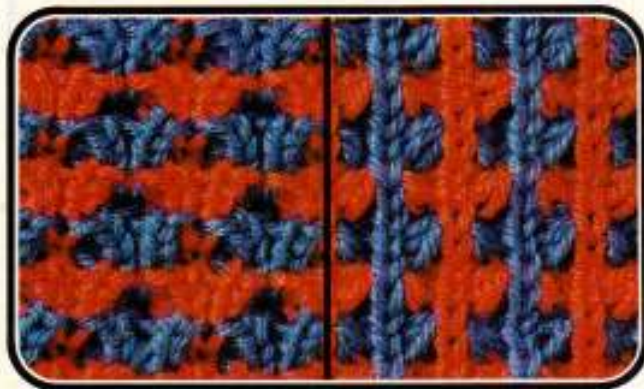

Handle up, orange strippers

Contrary to the needle rule, last needle at right and **left** on back bed

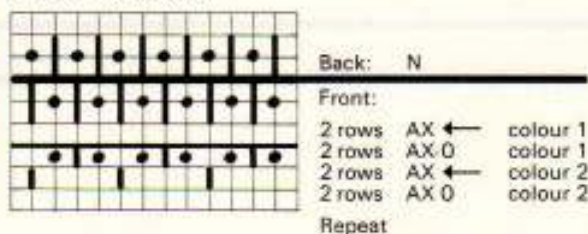

# Fancy stitch patterns



## Arran effect

Handle up, orange strippers

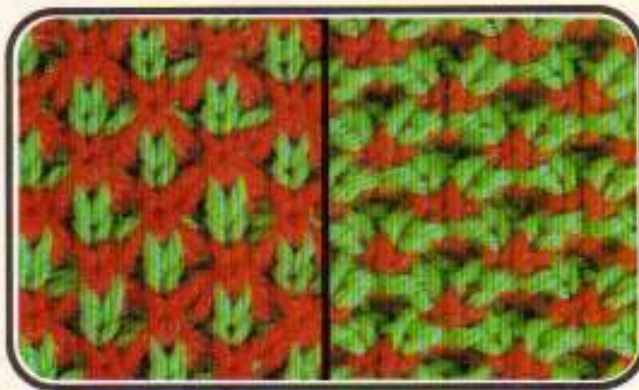
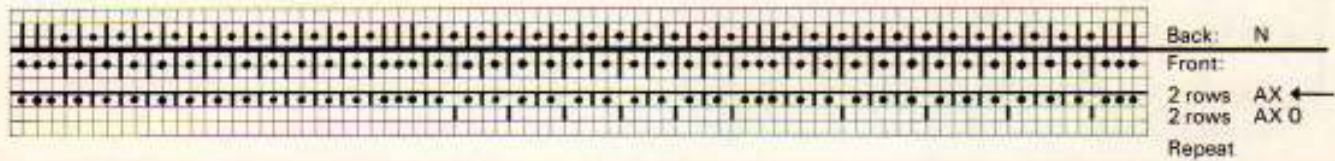

Handle up, orange strippers

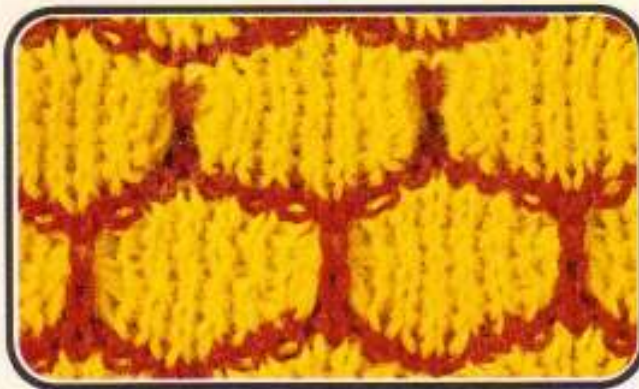
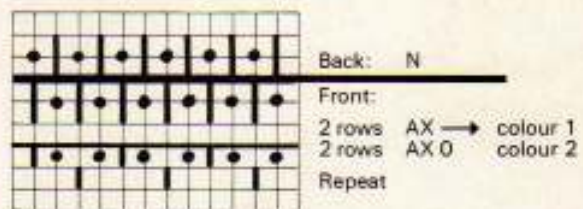

Handle down, orange strippers

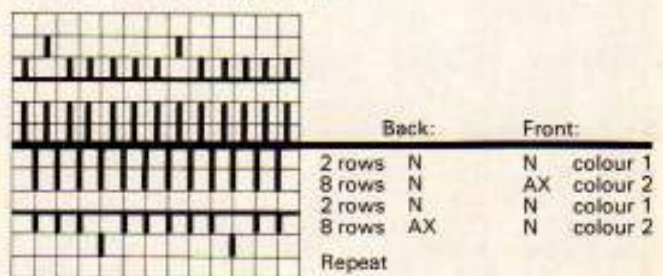

# Fancy stitch patterns



Handle down, orange strippers

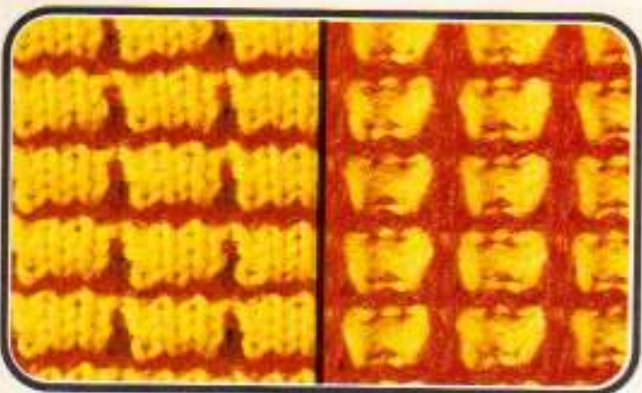
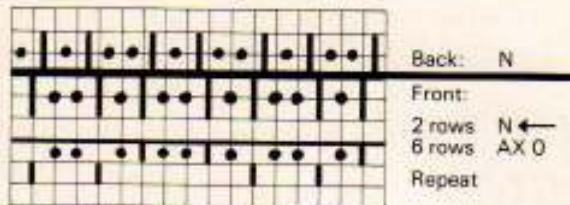

Handle down, orange strippers

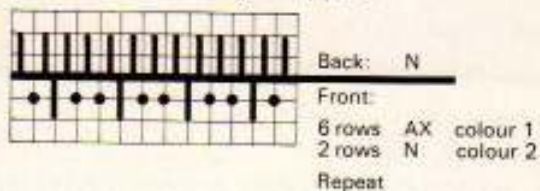

Handle down, black strippers

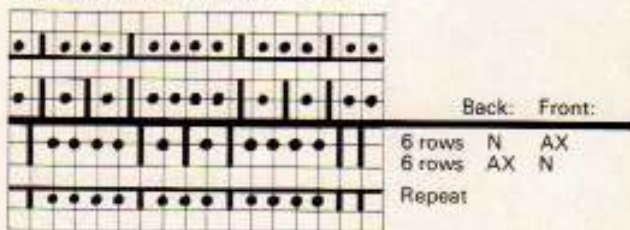

Handle down, black strippers

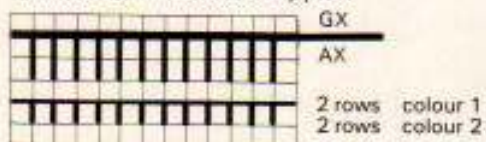

**Diagram:** (jac card 3)

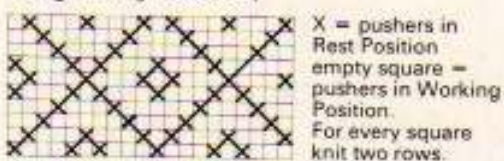

# Fancy stitch patterns

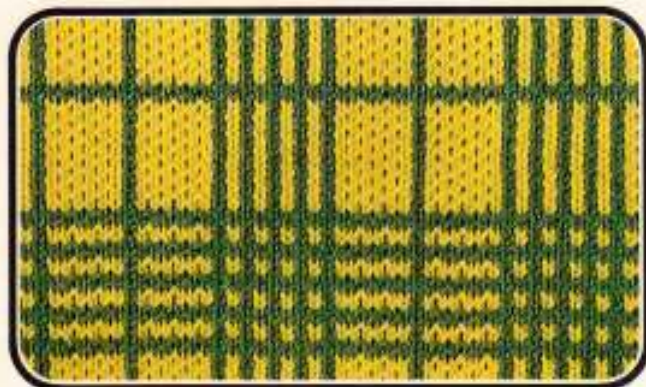

## Fairisle

Handle down, orange strippers

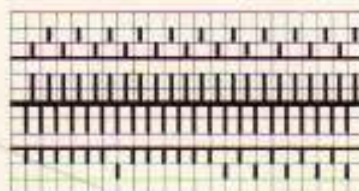

BX ↔  
BX ←

7 times | 2 rows colour 1  
          | 2 rows colour 2  
          | 4 rows colour 1  
7 times | 2 rows colour 1  
          | 2 rows colour 2  
          | 6 rows colour 1  
4 times | 2 rows colour 2  
          | 4 rows colour 1  
Repeat



## Fairisle

Handle down, orange strippers

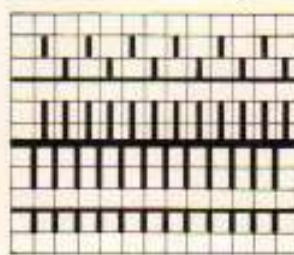

BX ↔  
BX ←

Arrange pushers  
acc. to diagram  
2 rows trimming colour  
2 rows main colour  
Repeat

Diagram: (jac card 46)

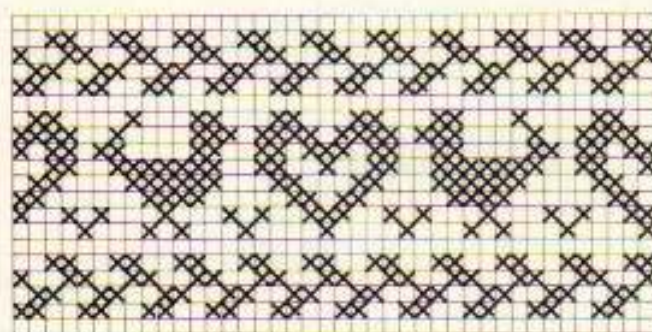

X = trimming colour = pushers in Rest Position  
empty square = main colour = pushers in Working Position  
1 square = 1 stitch = 2 rows = RC 4

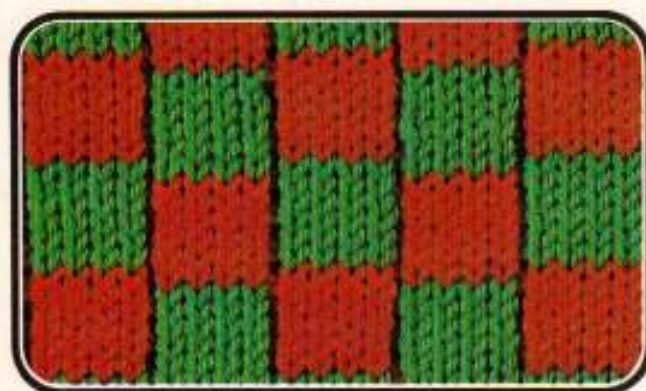

## Fairisle, reversible

Handle up, black strippers

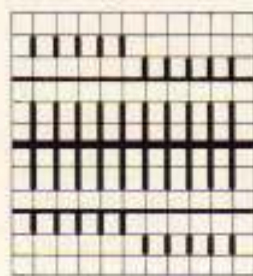

Back: Front:

11 rows BX ← BX ←  
1 row BX → BX →

2 rows colour 1  
2 rows colour 2  
Repeat

# Fancy stitch patterns



Handle down, black strippers

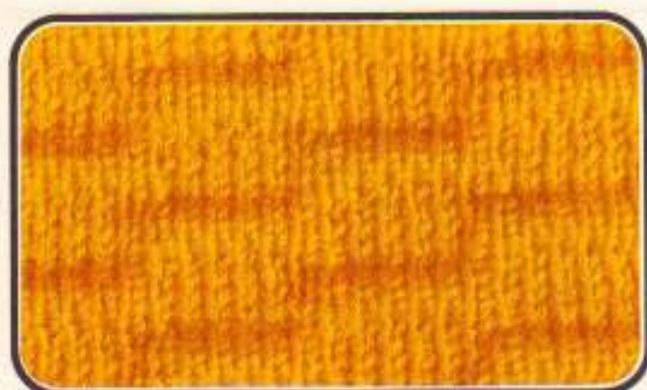
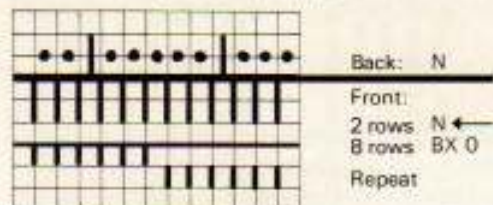

Handle down, black strippers

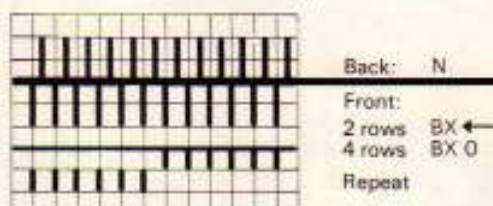

## Carpet stitch

Handle down, black strippers

Stitch size at front two to three numbers smaller than at back.

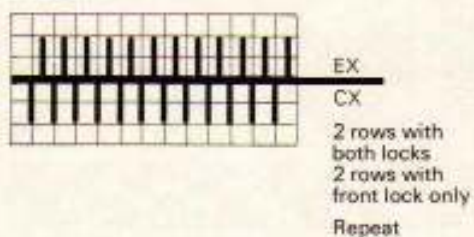

## Fancy tubular

Handle up, black strippers

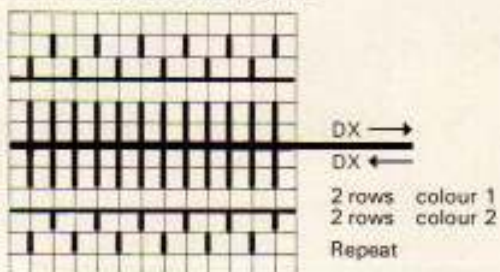

# Fancy stitch patterns



## Fancy tubular

Handle up, black strippers

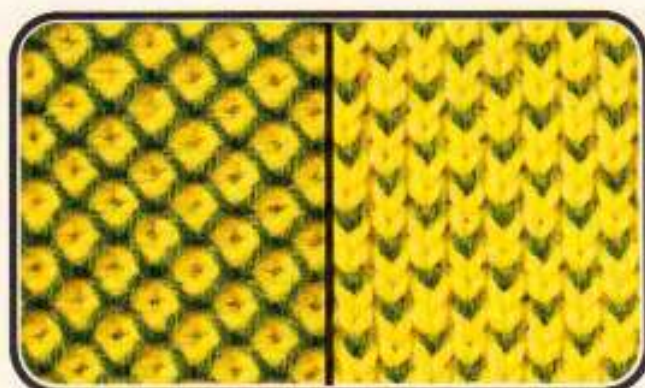
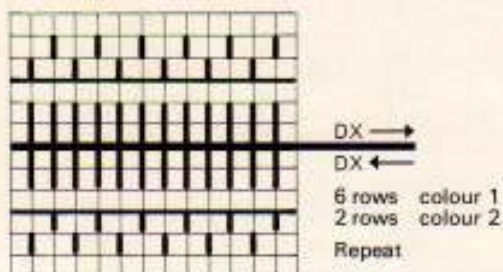

## Fancy tubular

Handle up, black strippers

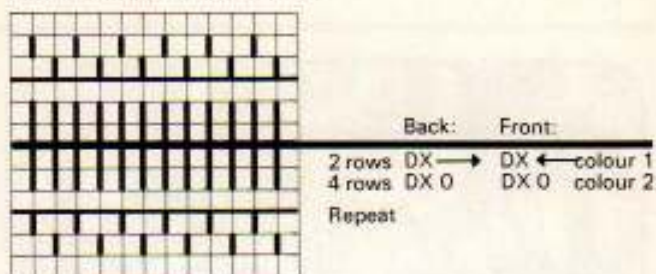

Handle down, orange strippers

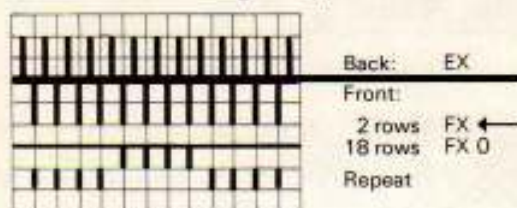

Handle down, orange strippers

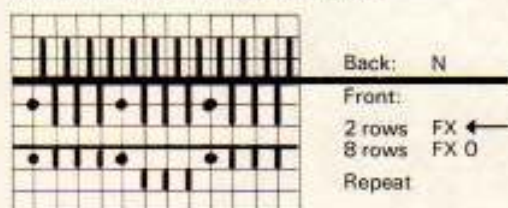

# Fancy stitch patterns

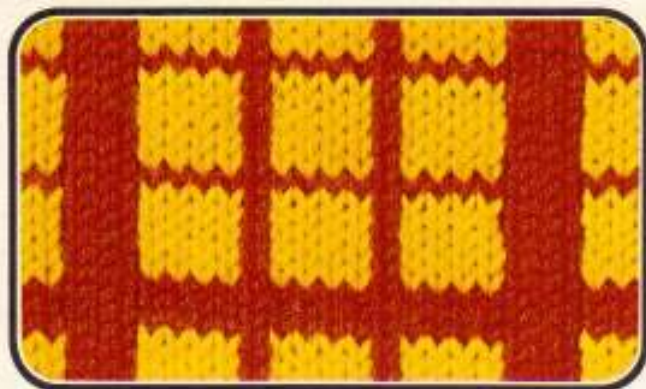

## Fairisle, tubular

Handle up, black strippers

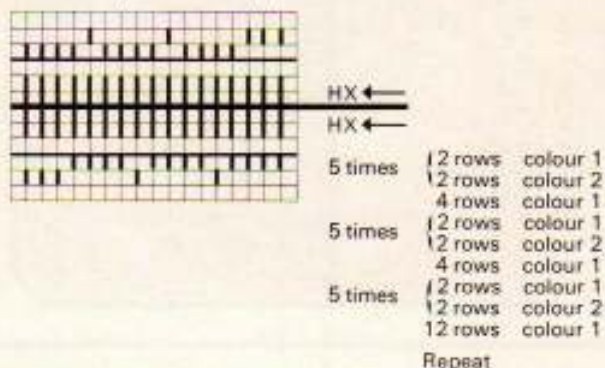

**Note:** If more than two rows are knitted with the same colour, then, every time the lock is on the right, the yarn has to be inserted into the needle head of the end needle at right back.



## Fairisle, tubular

Handle up, black strippers

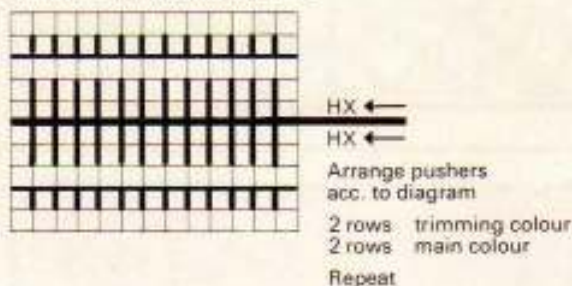

**Diagram:** (jac card 29)

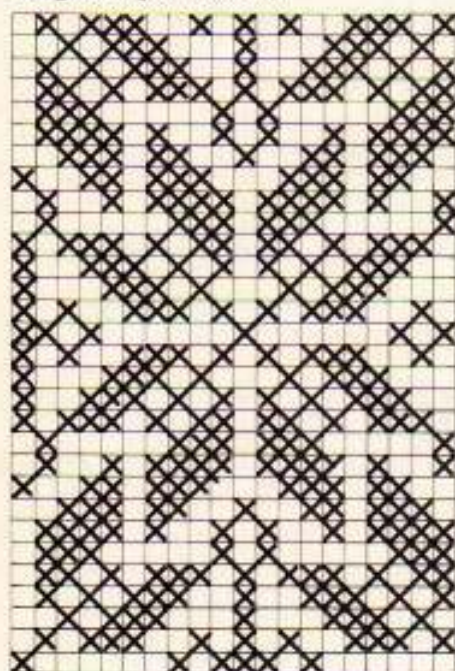

X = trimming colour = pushers in Rest Position  
 empty square = main colour = pushers in Working Position  
 1 square = 1 stitch =  
 1 row = RC 4.

**Note:** Arrange the pushers in such a way that each colour is being knitted by one of the two edge needles at left.  
 If this is not the case, then, every time the lock is on the left, insert the yarn into the needle head of the end needle at left front.

# Fancy stitch patterns

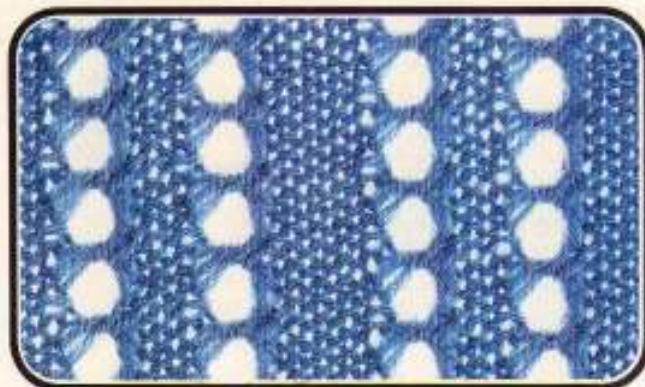

## Pattern with U 70 lock

Handle down, black strippers

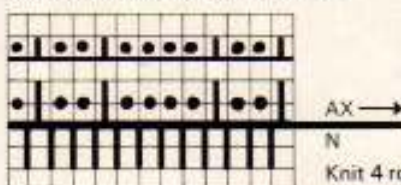

Knit 4 rows

Transfer stitches from back bed to front with U 70 lock.

Repeat

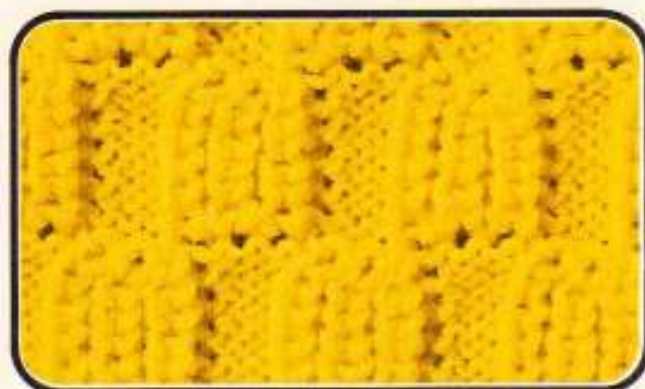

## Pattern with U 70 lock

Handle down, black strippers

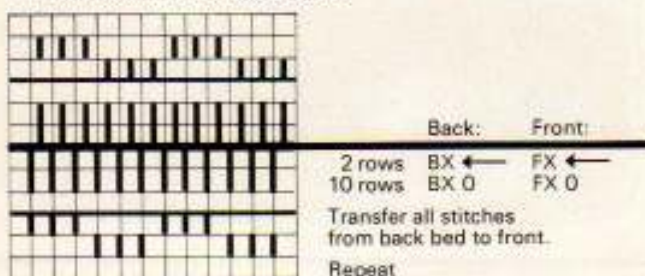

Transfer all stitches from back bed to front.

Repeat



## Pattern with U 70 lock

Handle down, black strippers



5 times | Needles at back in Working Position acc. to diagram. Knit 2 rows

Transfer all stitches from back bed to front.

5 times | Needles at back in Working Position acc. to diagram. Knit 2 rows.

Transfer all stitches from back bed to front.

Repeat.

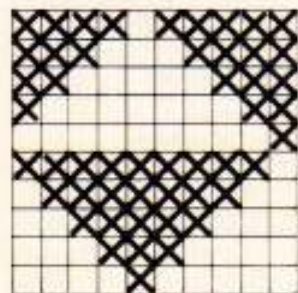

X = needle at back in Working Position

1 square =  
1 needle =  
2 rows



# Fancy stitch patterns

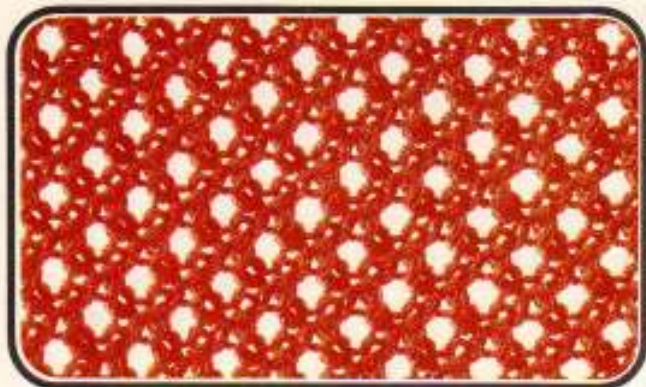

## Pattern with U 70 lock

Handle down, orange strippers

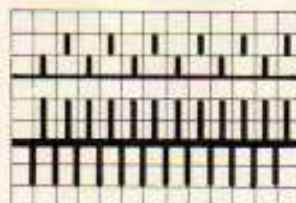

BX ←

N

Knit 2 rows.

Transfer all stitches from back bed to front.

Repeat



Before you start, rack back bed to the extreme right.

Handle down, black strippers

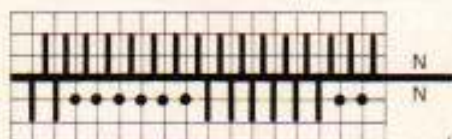

N

N

6 times

Knit 2 rows.  
Racking handle one full turn to the left.

6 times

Knit 2 rows.  
Racking handle one full turn to the right.

Repeat

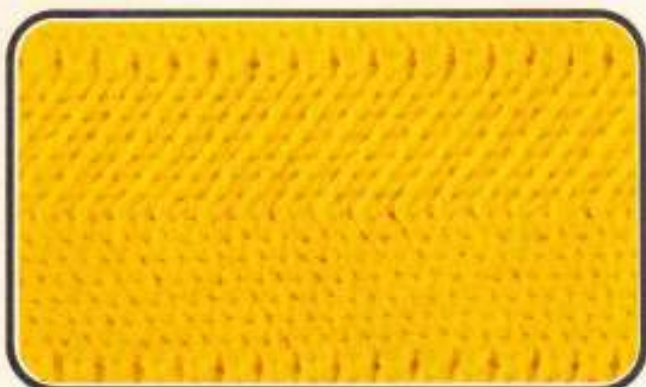

Handle down, orange strippers

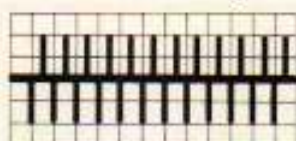

EX

EX

7 times

Racking handle one full turn to the left.  
Knit 1 row.  
Racking handle one full turn to the right.  
Knit 1 row.  
Knit 1 row without racking.

Repeat

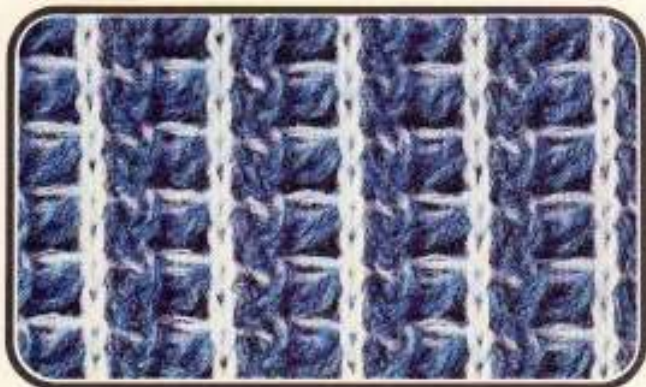

Handle down, orange strippers

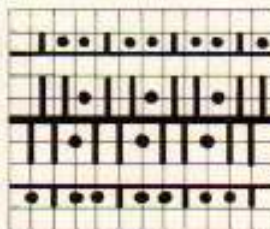

Back and front:

4 rows AX colour 1  
Racking handle one full turn to the left.

2 rows N colour 2  
Racking handle one full turn to the right.

Repeat

# Fancy stitch pattern



Handle down, black strippers  
Stitch size at back three numbers higher than at front

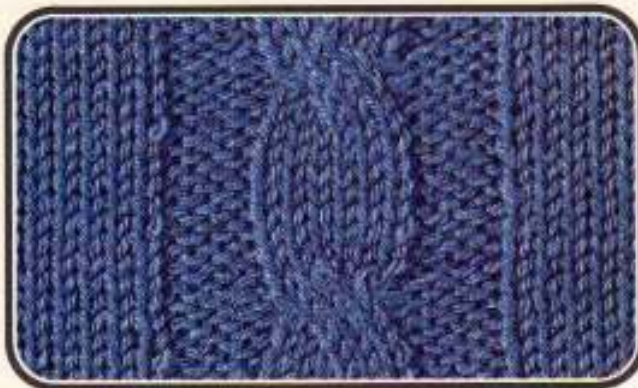
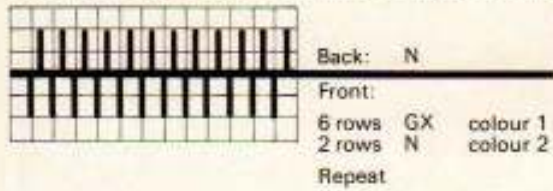

## Cable

Handle down, black strippers

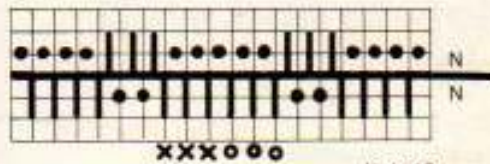

Knit 12 rows.  
Place stitches XXX onto the  
needles OOO, and stitches OOO  
onto the needles XXX.

Repeat



## Fringes

Handle down, orange strippers



Knit 2 rows.  
Racking handle one  
full turn to the left.

Knit 2 rows.  
Racking handle one  
full turn to the right.

Repeat



## Socks

If you follow our instructions carefully, and use the same yarn as for your test pieces on page 17, you will get socks fitting shoe sizes 38 to 39 (5 to 6).

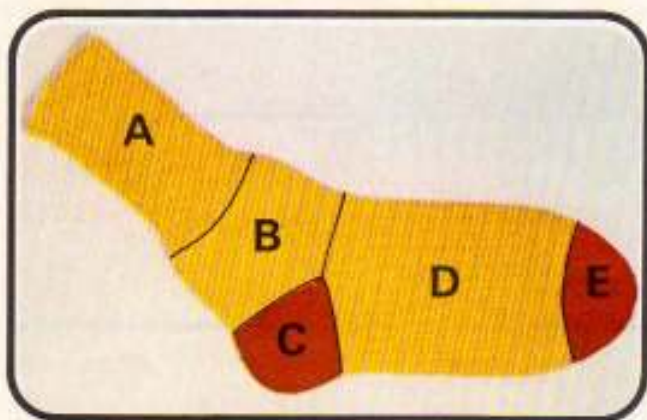

### A = cast-on and welt in 1:1 rib

**60 needles** (30 on back bed, 30 on front bed) in **1:1 division in Working Position**

**Tubular cast-on** (page 43)

**Handle up. Orange strippers**

Lock  $\frac{N}{N}$

**Stitch size on front and back lock 3 $\frac{3}{4}$**

**Knit 48 rows in 1:1 rib**

**Transfer stitches for tubular stocking stitch:**

1. Unravel the 15 end stitches at right. Fasten the yarn under the edge spring to stop it from interfering with the work.
2. Transfer all stitches from front bed to the needles on back bed (at back also put the empty needles, which are between the needles holding stitches, into Working Position).
3. At each end transfer 15 stitches to the front bed, in such a way that one can continue knitting tubular, as follows:

At right place 15 stitches onto deckercomb. Close the deckercomb with its protection rail. Turn the deckercomb as you would turn the page of a book. Transfer stitches to front needles.

At left transfer 15 stitches to front bed in the same way. Now the stitches have been transferred for tubular knitting, i.e. there are 30 stitches on each bed, with the knitting yarn on the right.

### Section B

**Row counter at zero**

Lock  $\frac{CX}{CX}$

**Stitch size on front and back bed 5 $\frac{1}{4}$**

**Black strippers**

**Knit RC 52**

## Section C, Heel

**Row counter at zero**

**At each side  $\blacktriangle-9 \times 1 \bullet 2, R \blacktriangle$**

The heel is knitted on the front bed only, as follows:

Lock  $\frac{GX}{BX}$

**On front bed 30 pushers in Working Position**

Lock at right

**At right put first pusher into Rest Position**

**Knit one row**

Lock at left

**At left put first pusher into Rest Position**

**Knit one row**

Continue knitting, always putting one pusher into Rest Position on the lock side, until there are nine pushers in Rest Position on each side. At the centre 12 needles remain in Working Position.

**At each side  $\blacktriangle+9 \times 1 \bullet 2, R \blacktriangle$**

**Note:** When you are putting the 9th pusher at left into Rest Position, you must at the same time return the 9th pusher at right to Working Position.

**Knit one row**

At left put the 9th pusher into Working Position, and so forth, i.e. continue putting the pushers on the opposite side of the lock into Working Position until all pushers are in Working Position.

**Note:** When you are putting the last pusher at left into Working Position (lock at right) you already have to prepare the lock for

## Section D

**Row counter at zero**

Lock  $\frac{CX}{CX}$

**Knit RC 120**

## Section E, Toe

**Row counter at zero**

**At each side  $-6 \times 1 \bullet RC 4$**

i.e. at each end on front and back bed move the two end stitches one needle in.

Knit RC 4

Repeat 5 times = RC 24

**At each side  $-7 \times 1 \bullet RC 2$**

i.e. decrease as above, but only knitting RC 2 between each decrease.

Repeat 6 times = RC 14

Finally, there remain four stitches on each bed.

**Break off yarn, thread end through the eight remaining stitches, and draw up tightly.**

# Sweater

Below you will find all the instructions which are needed to knit a classic sweater in stocking stitch, either with a turtle neck or with a round neck. Use yarn of medium thickness (length 430 m per 100 g / 135 yds per 1 oz). If you want to be sure that the results correspond with the given measurements, knit a test square first (page 82), and compare it with our **test square: 100 stitches = 32 cm (12½ inches), 100 rows = 24 cm (9½ inches)**. If your test square does not correspond with the above measurements, adjust the setting of the stitch size regulator until the correct measurements are obtained.



**Measurements:** Take your own measurements and compare them with our chart in order to find your own size. (10 cm = approx. 4 inches)

	36	38	40	42	44
To fit chest/bust	84cm	88cm	92cm	96cm	100cm
Length of sweater	59cm	61cm	62cm	63cm	64cm
Length of sweater sleeves	59cm	61cm	61,5cm	62cm	62cm

**Material:** from 300 to 400 grams (11 to 14 ozs)

On the following pages you will find in the left hand column of our charts all the instructions concerning working methods. On the right you will find the number of stitches and rows for the various sizes, against which you can check your own work, as well as the number of stitches which must remain on the needles at the end of every section.

# The back

The diagram opposite gives the measurements for a size 38, for the other sizes consult the chart below.

**Abbreviations:** st = stitch,  
R = row. St.S = stitch size,  
K = knit.  
+ 7 × 1 • 18. R = increase seven times one stitch every 18 rows.

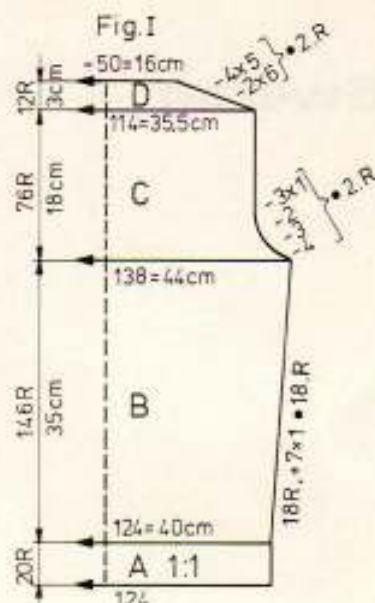
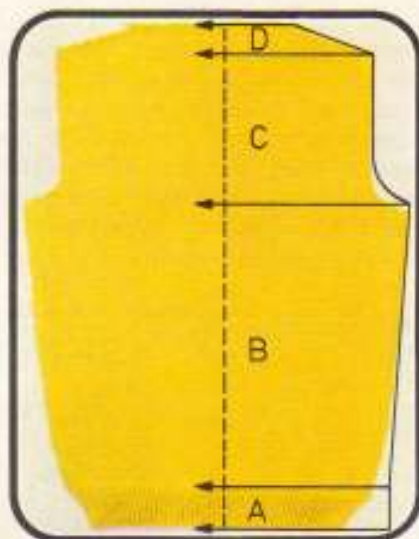

Size	36	38	40	42	44
A = tubular cast-on in 1:1 rib (p. 43) orange strippers Lock $\frac{N}{N}$ St. S $3\frac{1}{2}$	118 sts K 20 R	124 sts K 20 R	130 sts K 20 R	136 sts K 20 R	142 sts K 20 R
End of section A	118 sts = 38 cm	124 sts = 40 cm	130 sts = 41.5 cm	136 sts = 43.5 cm	142 sts = 45.5 cm
B = for stocking stitch transfer all sts to front (p. 40) black strippers Lock $\frac{GX}{N}$ St. S 5 Increase at each end (p. 50), knit stocking st.	+ 7 × 1 • 18. R 142 R = 34 cm	+ 7 × 1 • 18. R 146 R = 35 cm	+ 7 × 1 • 20. R 150 R = 36 cm	+ 7 × 1 • 20. R 150 R = 36 cm	+ 7 × 1 • 20. R 154 R = 37 cm
End of section B	132 sts = 42 cm	138 sts = 44 cm	144 sts = 46 cm	150 sts = 48 cm	156 sts = 50 cm
C = decrease at each end for armholes, knit stocking stitch.	$\begin{array}{l} -4 \\ -3 \\ -2 \\ -3 \times 1 \end{array} \cdot 2. R$ K 72 R = 17 cm	$\begin{array}{l} -4 \\ -3 \\ -2 \\ -3 \times 1 \end{array} \cdot 2. R$ K 76 R = 18 cm	$\begin{array}{l} -4 \\ -3 \\ -2 \\ -5 \times 1 \end{array} \cdot 2. R$ K 76 R = 18 cm	$\begin{array}{l} -4 \\ -3 \\ -2 \times 2 \\ -5 \times 1 \end{array} \cdot 2. R$ K 80 R = 19 cm	$\begin{array}{l} -5 \\ -4 \\ -3 \\ -2 \\ -4 \times 1 \end{array} \cdot 2. R$ K 80 R = 19 cm
End of section C	108 sts = 34.5 cm	114 sts = 35.5 cm	116 sts = 37 cm	118 sts = 37.5 cm	120 sts = 38 cm
D = decrease at each end to shape shoulder, (p. 54)	$-6 \times 5 \cdot 2. R$ K 12 R = 3 cm	$\begin{array}{l} -2 \times 6 \\ -4 \times 5 \end{array} \cdot 2. R$ K 12 R = 3 cm	$\begin{array}{l} -3 \times 6 \\ -3 \times 5 \end{array} \cdot 2. R$ K 12 R = 3 cm	$\begin{array}{l} -3 \times 6 \\ -3 \times 5 \end{array} \cdot 2. R$ K 12 R = 3 cm	$\begin{array}{l} -4 \times 6 \\ -2 \times 5 \end{array} \cdot 2. R$ K 12 R = 3 cm
End of section D, cast off	-48 sts = 15.5 cm	-50 sts = 16 cm	-50 sts = 16 cm	-52 sts = 16 cm	-52 sts = 16 cm

# The front

The diagram opposite gives the measurements for a size 38, for the other sizes consult the chart below.

**Abbreviations:** st = stitch,  
R = row, St. S = stitch size,  
K = knit.  
+7×1•18.R = increase seven times one stitch every 18 rows.

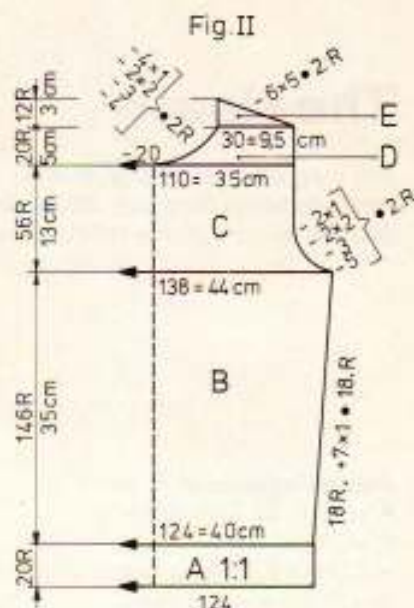
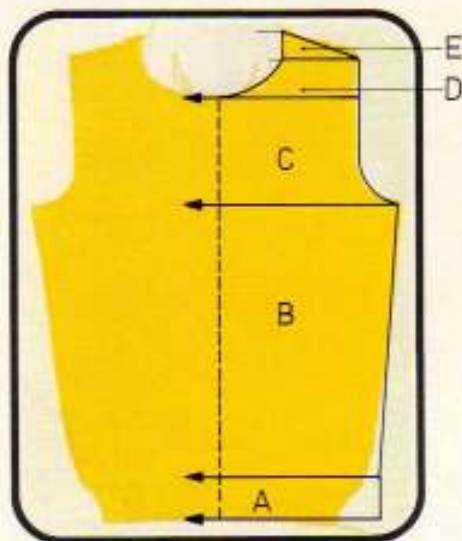

Size	36	38	40	42	44
A + B = knit as for back	118 sts	124 sts	130 sts	136 sts	142 sts
End of section B	132 sts = 42 cm	138 sts = 44 cm	144 sts = 46 cm	150 sts = 48 cm	156 sts = 50 cm
C = decrease at each end for armholes, knit stocking stitch.	$\begin{array}{l} -5 \\ -3 \\ -2 \times 2 \\ -2 \times 1 \end{array} \cdot 2.R$ K 50 R = 12 cm	$\begin{array}{l} -5 \\ -3 \\ -2 \times 2 \\ -2 \times 1 \end{array} \cdot 2.R$ K 54 R = 13 cm	$\begin{array}{l} -5 \\ -4 \\ -3 \\ -2 \\ -2 \times 1 \end{array} \cdot 2.R$ K 54 R = 13 cm	$\begin{array}{l} -5 \\ -4 \\ -3 \\ -2 \times 2 \\ -2 \times 1 \end{array} \cdot 2.R$ K 58 R = 14 cm	$\begin{array}{l} -6 \\ -4 \\ -3 \\ -2 \times 2 \\ -3 \times 1 \end{array} \cdot 2.R$ K 58 R = 14 cm
End of section C	104 sts = 33 cm	110 sts = 35 cm	112 sts = 36 cm	114 sts = 36.5 cm	116 sts = 37 cm
<b>1st shoulder</b> D = cast off centre sts. Divide work. Lock $\frac{GX}{BX}$ For right half pushers in Working Position. Decrease at left for neck, at right knit straight, knit stocking stitch.	$\begin{array}{l} -18 \text{ sts} \\ 43 \text{ pushers} \\ -4 \\ -3 \\ -2 \times 2 \\ -4 \times 1 \end{array} \cdot 2.R$ K 20 R = 5 cm	$\begin{array}{l} -20 \text{ sts} \\ 44 \text{ pushers} \\ -4 \\ -3 \\ -2 \times 2 \\ -4 \times 1 \end{array} \cdot 2.R$ K 20 R = 5 cm	$\begin{array}{l} -20 \text{ sts} \\ 46 \text{ pushers} \\ -4 \\ -3 \\ -2 \times 2 \\ -3 \times 1 \end{array} \cdot 2.R$ K 20 R = 5 cm	$\begin{array}{l} -22 \text{ sts} \\ 46 \text{ pushers} \\ -4 \\ -3 \\ -2 \times 2 \\ -2 \times 1 \end{array} \cdot 2.R$ K 20 R = 5 cm	$\begin{array}{l} -22 \text{ sts} \\ 47 \text{ pushers} \\ -4 \\ -3 \\ -2 \times 2 \\ -2 \times 1 \end{array} \cdot 2.R$ K 20 R = 5 cm
End of section D	28 sts = 9 cm	30 sts = 9.5 cm	32 sts = 10 cm	33 sts = 10.5 cm	34 sts = 11 cm
E = knit straight at left, decrease at right to shape shoulder, knit stocking stitch.	$\begin{array}{l} -2 \times 4 \\ -4 \times 5 \end{array} \cdot 2.R$ K 12 R = 3 cm	$-6 \times 5 \cdot 2.R$ K 12 R = 3 cm	$\begin{array}{l} -2 \times 4 \\ -4 \times 6 \end{array} \cdot 2.R$ K 12 R = 3 cm	$\begin{array}{l} -3 \times 5 \\ -3 \times 6 \end{array} \cdot 2.R$ K 12 R = 3 cm	$\begin{array}{l} -2 \times 5 \\ -4 \times 6 \end{array} \cdot 2.R$ K 12 R = 3 cm
<b>2nd shoulder</b> D + E = knit with reversed shapings					

# The sleeve

The diagram opposite gives the measurements for a size 38, for the other sizes consult the chart below.

**Abbreviations:** st = stitch,  
R = row, St. S = stitch size,  
K = knit.  
+22×1•8 R = increase 22 times  
one stitch every 8 rows.

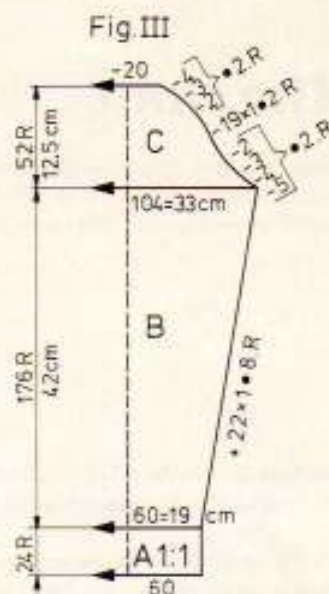
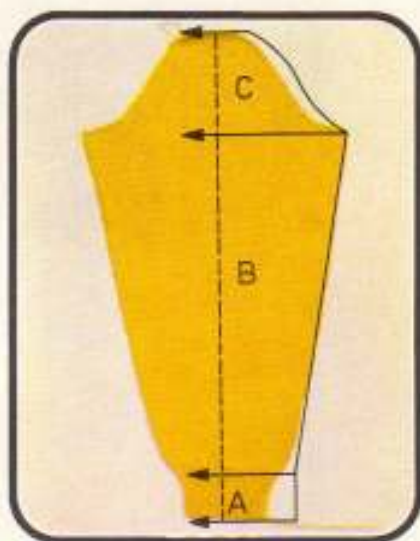

Size	36	38	40	42	44
A = tubular cast-on in 1:1 rib (p. 43) orange strippers Lock $\frac{N}{N}$ St. S $3\frac{1}{2}$	56 sts K 24 R	60 sts K 24 R	60 sts K 24 R	62 sts K 24 R	64 sts K 24 R
End of section A	56 sts = 18 cm	60 sts = 19 cm	60 sts = 19 cm	62 sts = 20 cm	64 sts = 20,5 cm
B = for stocking stitch transfer all sts to front (p. 40) black strippers Lock $\frac{GX}{N}$ St. S 5 Increase at each end (p. 50), knit st. st.	+21×1•8 R 168 R = 40 cm	+22×1•8 R 176 R = 42 cm	+22×1•8 R 176 R = 42 cm	+22×1•8 R 180 R = 43 cm	+22×1•8 R 180 R = 44 cm
End of section B	98 sts = 31 cm	104 sts = 33 cm	104 sts = 33 cm	106 sts = 34 cm	108 sts = 34,5 cm
C = decrease at each end to shape sleeve head (p. 54)	-5   -4   • 2 R -3   • 2 R -2   -18×1•2 R -2   -3   • 2 R -4   K 50 R = 12 cm	-5   -4   • 2 R -3   • 2 R -2   -19×1•2 R -2   • 2 R -3   • 2 R -4   K 52 R = 12,5 cm	-5   -4   • 2 R -3   • 2 R -2   -19×1•2 R -2   • 2 R -3   • 2 R -4   K 52 R = 12,5 cm	-5   -4   • 2 R -3   • 2 R -2   -20×1•2 R -2   • 2 R -3   • 2 R -4   K 54 R = 13 cm	-5   -4   • 2 R -3   • 2 R -2   -21×1•2 R -2   • 2 R -3   • 2 R -4   K 56 R = 13,5 cm
End of section C, cast off	-16 sts = 5 cm	-20 sts = 6,5 cm	-20 sts = 6,5 cm	-20 sts = 6,5 cm	-20 sts = 6,5 cm

# The neckband



**Abbreviations:** st = stitch,  
R = row, St. S = stitch size,  
K = knit.

Size	36	38	40	42	44
Tubular cast-on in 1:1 rib (p. 43) Lock $\frac{N}{N}$ St. S $3\frac{1}{2}$ Knit in 1:1 rib	146 sts = 44 cm K 6 R	150 sts = 45 cm K 6 R	154 sts = 46 cm K 6 R	158 sts = 47 cm K 6 R	162 sts = 48 cm K 6 R
Transfer all sts to front, St. S 5, knit stocking stitch.	K 2 R	K 2 R	K 2 R	K 2 R	K 2 R
A few rows with contrast yarn, release sts (p. 16)					
<b>Turtle neck:</b> Knit as for neckband, but knit 84 rows					

When you have finished, press the parts (page 80), and join them (page 81). Sew the side seams with mattress stitch, the shoulder seams from the inside with back stitch. Set in the sleeves in the same way. Attach the neckband or turtle neckband from the outside st by st with back stitch to the neck, unravelling contrast yarn as you go.



## Blocking and pressing

Before making up a garment, almost all fabrics made of wool, as well as some synthetics, have to be pressed.

**Exceptions for wool:** Raised patterns must never be pressed.

**For synthetic yarns:** Always press the test square first and check the result. See also the chapter on test squares, page 82.

### Pinning out to size

Before pressing, each part should be pinned out to size on an ironing board.

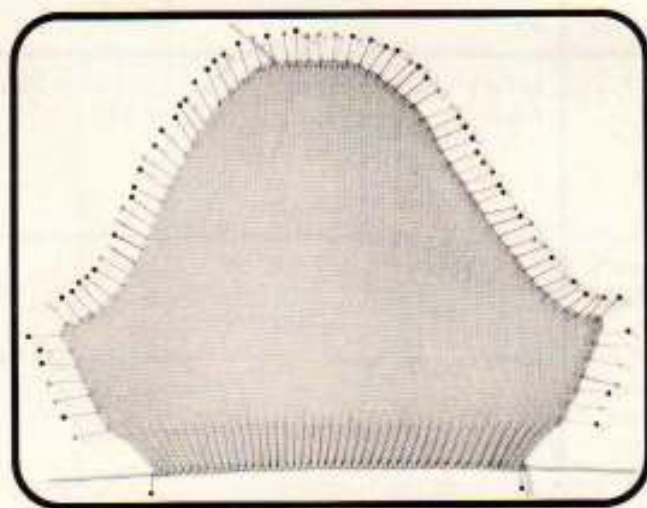

Proceed as follows: Check the measurements on your diagram. Transfer these, with the aid of a tape measure, to the ironing board, marking the corners with pins. In the case of a straight edge use, say, your finger nail to mark the straight line on the ironing board. Pin the two corners first, then place the next pin into the centre of the line and so forth. Doing it this way prevents you from pulling the fabric out of shape. Leave approx. 1 cm ( $\frac{1}{2}$  inch) between pins.

### Pressing

Place a damp cloth over the pinned-out parts, and press very lightly with a hot iron. (Never use pressure). Wait for the pieces to dry completely, before removing them from the ironing board.

### Pressing welts and borders

In order to retain their elasticity welts and borders must be pressed in the following manner:

Insert a fine knitting needle into the tubular rows of the cast-on, and hold it in position by pinning the ends of the needle to the ironing board. Now pull the welt or border lengthwise and hold it while you press it.

## Seams

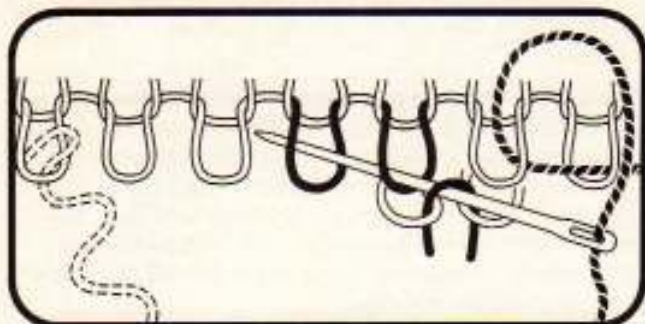

### **Making a hem**

Stitch by stitch sew open row of stitches, always picking up two stitches at a time and unravelling the contrast yarn stitch by stitch.

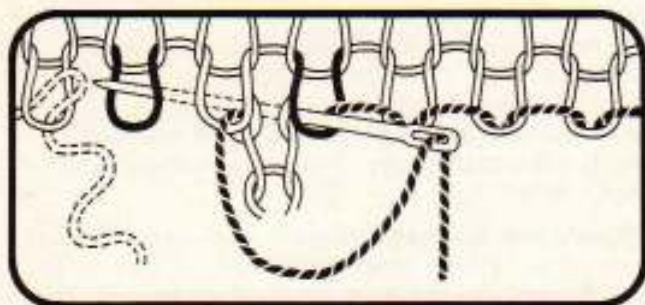

### **Back stitching, stitch by stitch**

Enter into the open stitch at right of the stitch sewn last and emerge from the open stitch at left of it, unravelling contrast yarn stitch by stitch.

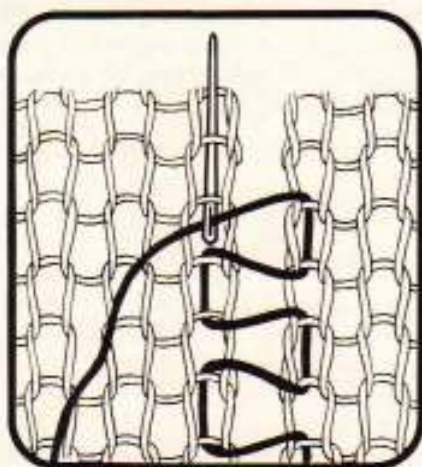

### **The mattress stitch on the right side of the fabric**

For inconspicuous side seams.  
Sewn on the right side of the knitting.

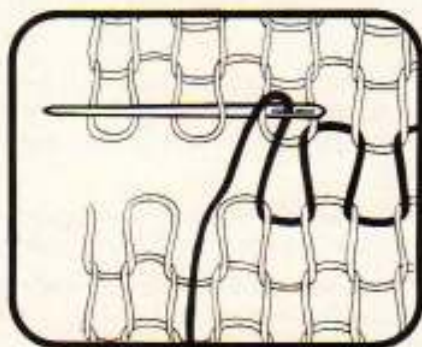

### **The graft stitch**

With right side of the knitting facing you, form the missing row of stitches.

# Calculation of garments

## Making a test square

To knit your own designs, it is absolutely vital that you make a test square first, for only thus can you work out the number of stitches and rows you will have to knit.

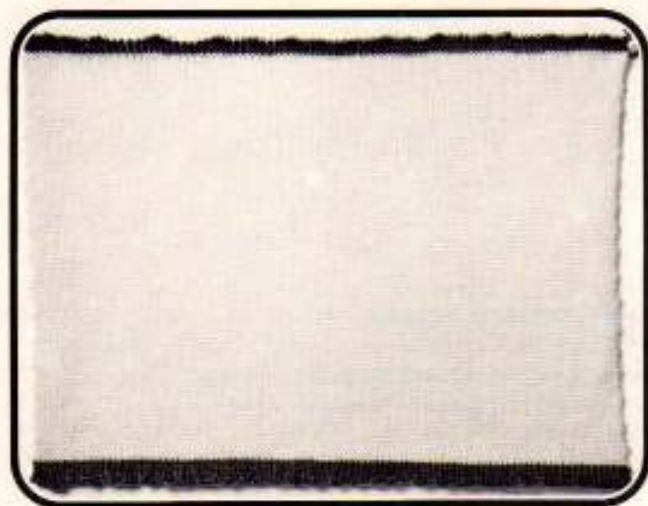

**A test square** is always knitted in the yarn, the pattern, the stitch size, and the yarn tension you will be using for your garment.

Knit **100 rows with 100 stitches**, for only a test square of this size will ensure the accuracy of your calculations.

**Remember to always count all the stitches actually knitted;** in double-bed knitting, therefore, those on the back bed also. Equally, for patterns where all the needles are not used, the empty ones are not counted. If you are knitting with every alternate needle, knit with 50 stitches only. Then, when you are doing your calculations, you simply double the measurements for the stitches.

**Casting on and off always with contrast yarn.**

After casting on knit approx. 6 to 10 rows in contrast yarn, before changing to your main yarn. Then, before you release your knitting, change back to contrast yarn. Knit 10 to 12 rows and release.

**In the case of materials which need pressing under a damp cloth,** press your test square first, and then measure it.

**When using synthetic yarns** it is advisable to measure the test square before pressing it, in order to see how the material reacts. If you liked the texture of the fabric better before pressing it, then use the measurements you took before pressing. Otherwise, measure the test square again after pressing it, as the measurements may well have altered. It is always a good thing to let the test square rest for 24 hours before measuring it.

## Calculating the stitches and rows

To do this, use the four charts on the next two pages.

In the **top horizontal row** look up the measurement which you have obtained from your test square. The vertical column directly underneath is for your calculations.

In the **vertical column** on each side, look up the measurement you need for your pattern.

Use the same method for calculating the stitches and rows. The simplest way is to first calculate the number of stitches, and then the rows.

# Calculation of garments

## An example

Say the 100 stitches of your test square measure 36 cm (14 $\frac{1}{4}$  inches).

Look up the 36 cm (14 $\frac{1}{4}$ " ) in the top horizontal row of your chart, and mark the column underneath. Now, you want to find out how many stitches have to be cast on for a sleeve measuring 29 cm (11 $\frac{1}{2}$  inches) at the wrist. Look in the vertical column at the extreme left or right for the 20 cm (8"). Move

across from there, and you will arrive at number 56 in the previously marked vertical column, i.e. 20 cm = 56 stitches.

Do the same for the remaining 9 cm (3 $\frac{1}{2}$  inches), and you get 9 cm = 25 stitches.

Now add up 56 and 25 = 81, and you will know that you have to cast on 81 stitches for a sleeve which must be 29 cm wide.

For test squares measuring 30 to 39.5 cm

cm	30	30,5	31	31,5	32	32,5	33	33,5	34	34,5	35	35,5	36	36,5	37	37,5	38	38,5	39	39,5	cm	
0,5	1-2	1-2	1-2	1-2	1-2	1-2	1-2	1-2	1-2	1-2	1-2	1-2	1-2	1-2	1-2	1-2	1-2	1-2	1-2	1-2	1-2	0,5
1	3-4	3-4	3-4	3-4	3	3	3	3	2-3	2-3	2-3	2-3	2-3	2-3	2-3	2-3	2-3	2-3	2-3	2-3	2-3	1
2	7	7	6	6	6	6	6	6	6	6	6	6	6	5	5	5	5	5	5	5	5	2
3	10	10	10	10	9	9	9	9	9	9	8	8	8	8	8	8	8	8	8	8	8	3
4	13	13	13	13	13	12	12	12	12	12	11	11	11	11	11	11	11	10	10	10	10	4
5	17	16	16	16	16	15	15	15	15	14	14	14	14	14	14	13	13	13	13	13	13	5
6	20	20	19	19	19	18	18	18	18	17	17	17	17	16	16	16	16	16	15	15	15	6
7	23	23	23	22	22	22	21	21	21	20	20	20	19	19	19	19	18	18	18	18	18	7
8	27	26	26	25	25	25	24	24	24	23	23	23	22	22	22	21	21	21	21	20	20	8
9	30	30	29	29	28	28	27	27	26	26	26	25	25	25	24	24	24	23	23	23	23	9
10	33	33	32	32	31	31	30	30	29	29	29	28	28	27	27	27	26	26	26	25	25	10
20	67	66	65	64	63	62	61	60	59	58	57	56	56	55	54	53	53	52	51	51	51	20
30	100	98	97	95	94	92	91	90	88	87	86	85	83	82	81	80	79	78	77	76	76	30
40	133	131	129	127	125	123	121	119	118	116	114	113	111	110	108	107	105	104	103	101	101	40
50	167	164	161	159	156	154	151	149	147	145	143	141	139	137	135	133	132	130	128	127	127	50
60	200	197	194	191	188	185	181	179	176	174	171	169	167	164	162	160	158	156	154	152	152	60
70	233	230	226	222	219	215	212	209	206	203	200	197	194	192	189	187	184	182	179	177	177	70
80	267	262	258	254	250	246	242	239	235	232	229	225	222	219	216	213	211	208	205	203	203	80
90	300	295	290	286	281	277	273	269	265	261	257	254	250	247	243	240	237	234	231	228	228	90

## How to calculate increases and decreases

Now, using an example, let us try and work out how to increase and decrease.

Your measurements show that your sleeves have to measure 29 cm (11 $\frac{1}{2}$  inches) at the wrists, and 38 cm (15 inches) below the shoulders. You have therefore worked out:

**29 cm = 81 stitches**

**38 cm = 105 stitches**

The length of the sleeves from wrists to below shoulders is

**44 cm = 152 rows**

Accordingly, when knitting 152 rows you will have to increase 24 stitches, namely 12 stitches on each side of the sleeves. Result:

**152 rows : 12 = 12, leaving 8**

This means you have to increase 1 stitch every 12th row on each side.

**+ 12 x 1 = 12. R**

Knit 4 rows first before you start to increase.

It would be a good idea to draw up a short list on which to note down the number showing on the row counter when it is time for you to increase.

Like this:

4  
16  
28  
40  
52  
64  
76  
88  
100 etc.

Now you are sure to know where to continue, should you get interrupted at any time. A quick glance at your row counter and your list will tell you exactly when to increase.

# Calculation of garments

For test squares measuring 10 to 19,5 cm

cm	10	10,5	11	11,5	12	12,5	13	13,5	14	14,5	15	15,5	16	16,5	17	17,5	18	18,5	19	19,5	cm
0,5	5	4-5	4-5	4-5	4-5	4	3-4	3-4	3-4	3-4	3-4	3-4	3	3	3	2-3	2-3	2-3	2-3	2-3	0,5
1	10	10	9	8-9	8	8	7-8	7-8	7	7	6-7	6-7	6-7	6	6	5-6	5-6	5-6	5-6	5	1
2	20	19	18	17	16	16	15	15	14	14	13	13	13	12	12	11	11	11	11	10	2
3	30	29	27	26	25	24	23	22	21	21	20	19	19	18	18	17	17	16	16	15	3
4	40	38	36	35	33	32	31	30	28	28	27	26	25	24	24	23	22	22	21	21	4
5	50	48	45	43	42	40	38	37	36	34	33	32	31	30	29	29	28	27	26	26	5
6	60	57	55	52	50	48	46	44	43	41	40	39	38	36	35	34	33	32	32	31	6
7	70	67	64	61	58	56	54	52	50	48	47	45	44	42	41	40	39	38	37	36	7
8	80	76	73	70	67	64	62	59	57	55	53	52	50	48	47	46	44	43	42	41	8
9	90	86	82	78	75	72	69	67	64	62	60	58	56	55	53	51	50	49	47	46	9
10	100	95	91	87	83	80	77	74	71	69	67	65	63	61	59	57	56	54	53	51	10
20	200	190	182	174	167	160	154	148	143	138	133	129	125	121	118	114	111	108	105	103	20
30	300	286	273	261	250	240	231	222	214	207	200	194	188	182	176	171	167	162	158	154	30
40				348	333	320	308	296	285	276	267	258	250	242	235	229	222	216	211	205	40
50									357	345	333	323	313	303	294	286	278	270	263	256	50
60															353	343	333	324	316	308	60
70																				358	70
80																					80
90																					90

For test squares measuring 20 to 29,5 cm

cm	20	20,5	21	21,5	22	22,5	23	23,5	24	24,5	25	25,5	26	26,5	27	27,5	28	28,5	29	29,5	cm
0,5	2-3	2-3	2-3	2-3	2-3	2	2	2	2	2	2	1-2	1-2	1-2	1-2	1-2	1-2	1-2	1-2	1-2	0,5
1	5	4-5	4-5	4-5	4-5	4-5	4-5	4-5	4	4	4	4	3-4	3-4	3-4	3-4	3-4	3-4	3-4	3-4	1
2	10	10	10	9	9	9	9	9	8	8	8	8	8	8	7	7	7	7	7	7	2
3	15	15	14	14	14	13	13	13	13	12	12	12	12	11	11	11	11	11	10	10	3
4	20	20	19	19	18	18	17	17	17	16	16	16	15	15	15	15	14	14	14	14	4
5	25	24	24	23	23	22	22	21	21	20	20	20	19	19	19	18	18	18	17	17	5
6	30	29	29	28	27	27	26	26	25	24	24	24	23	23	22	22	21	21	21	20	6
7	35	34	33	33	32	31	30	30	29	29	28	27	27	26	26	25	25	25	24	24	7
8	40	39	38	37	36	36	35	34	33	33	32	31	31	30	30	29	29	28	28	27	8
9	45	44	43	42	41	40	39	38	38	37	36	35	35	34	33	33	32	32	31	31	9
10	50	49	48	47	45	44	43	43	42	41	40	39	38	38	37	36	36	35	34	34	10
20	100	98	95	93	91	89	87	85	83	82	80	78	77	75	74	73	71	70	69	68	20
30	150	146	143	140	136	133	130	128	125	122	120	118	115	113	111	109	107	105	103	102	30
40	200	195	190	186	182	178	174	170	167	163	160	157	154	151	148	145	143	140	138	136	40
50	250	244	238	233	227	222	217	213	208	204	200	196	192	189	185	182	179	175	172	169	50
60	300	293	286	279	273	267	261	255	250	245	240	235	231	226	222	218	214	211	207	203	60
70	350	341	333	326	318	311	304	298	292	286	280	274	269	264	259	255	250	246	241	237	70
80						356	348	340	333	327	320	313	308	302	296	291	286	281	276	271	80
90												353	346	340	333	327	321	316	310	305	90

# Calculation of garments

For test squares measuring 30 to 39,5 cm

cm	30	30,5	31	31,5	32	32,5	33	33,5	34	34,5	35	35,5	36	36,5	37	37,5	38	38,5	39	39,5	cm
0,5	1-2	1-2	1-2	1-2	1-2	1-2	1-2	1-2	1-2	1-2	1-2	1-2	1-2	1-2	1-2	1-2	1-2	1-2	1-2	1-2	0,5
1	3-4	3-4	3-4	3-4	3	3	3	3	2-3	2-3	2-3	2-3	2-3	2-3	2-3	2-3	2-3	2-3	2-3	2-3	1
2	7	7	6	6	6	6	6	6	6	6	6	6	6	5	5	5	5	5	5	5	2
3	10	10	10	10	9	9	9	9	9	9	9	8	8	8	8	8	8	8	8	8	3
4	13	13	13	13	13	12	12	12	12	12	11	11	11	11	11	11	11	10	10	10	4
5	17	16	16	16	16	15	15	15	15	14	14	14	14	14	14	13	13	13	13	13	5
6	20	20	19	19	19	18	18	18	18	17	17	17	17	16	16	16	16	16	15	15	6
7	23	23	23	22	22	22	21	21	21	20	20	20	19	19	19	19	18	18	18	18	7
8	27	26	26	25	25	25	24	24	24	23	23	23	22	22	22	21	21	21	21	20	8
9	30	30	29	29	28	28	27	27	26	26	26	25	25	25	24	24	24	23	23	23	9
10	33	33	32	32	31	31	30	30	29	29	29	28	28	27	27	27	26	26	26	25	10
20	67	66	65	64	63	62	61	60	59	58	57	56	56	55	54	53	53	52	51	51	20
30	100	98	97	95	94	92	91	90	88	87	86	85	83	82	81	80	79	78	77	76	30
40	133	131	129	127	125	123	121	119	118	116	114	113	111	110	108	107	105	104	103	101	40
50	167	164	161	159	156	154	151	149	147	145	143	141	139	137	135	133	132	130	128	127	50
60	200	197	194	191	188	185	181	179	176	174	171	169	167	164	162	160	158	156	154	152	60
70	233	230	226	222	219	215	212	209	206	203	200	197	194	192	189	187	184	182	179	177	70
80	267	262	258	254	250	246	242	239	235	232	229	225	222	219	216	213	211	208	205	203	80
90	300	295	290	286	281	277	273	269	265	261	257	254	250	247	243	240	237	234	231	228	90

For test squares measuring 40 to 50 cm

cm	40	40,5	41	41,5	42	42,5	43	43,5	44	44,5	45	45,5	46	46,5	47	47,5	48	48,5	49	49,5	50	cm
0,5	1-2	1-2	1-2	1-2	1-2	1-2	1-2	1-2	1-2	1-2	1	1	1	1	1	1	1	1	1	1	0,5	
1	2-3	2-3	2-3	2-3	2-3	2-3	2-3	2-3	2-3	2-3	2	2	2	2	2	2	2	2	2	2	1	
2	5	5	5	5	5	5	5	5	5	4	4	4	4	4	4	4	4	4	4	4	2	
3	8	7	7	7	7	7	7	7	7	7	7	7	6	6	6	6	6	6	6	6	3	
4	10	10	10	10	10	9	9	9	9	9	9	9	9	9	8	8	8	8	8	8	4	
5	13	12	12	12	12	12	11	11	11	11	11	11	11	11	11	10	10	10	10	10	5	
6	15	15	15	14	14	14	14	14	14	13	13	13	13	13	13	12	12	12	12	12	6	
7	18	17	17	17	17	16	16	16	16	16	15	15	15	15	15	15	14	14	14	14	7	
8	20	20	20	19	19	19	19	18	18	18	18	18	17	17	17	17	16	16	16	16	8	
9	23	22	22	22	21	21	21	21	20	20	20	20	20	19	19	19	19	18	18	18	9	
10	25	25	25	24	24	24	23	23	23	22	22	22	22	22	21	21	21	20	20	20	10	
20	50	49	49	48	48	47	47	46	45	45	44	44	43	43	43	42	42	41	41	40	20	
30	75	74	73	72	71	71	70	69	68	67	67	66	65	65	64	63	62	62	61	61	30	
40	100	99	98	96	95	94	93	92	91	90	89	88	87	86	85	84	83	82	81	80	40	
50	125	123	122	121	119	118	116	115	114	112	111	110	109	108	106	105	104	103	102	101	50	
60	150	148	146	145	143	141	140	138	136	135	133	132	130	129	128	126	125	124	122	121	60	
70	175	173	171	169	167	165	163	161	159	157	156	154	152	151	149	147	146	144	143	141	70	
80	200	198	195	193	190	188	186	184	181	180	178	176	174	172	170	168	167	165	163	162	80	
90	225	222	220	217	214	212	209	207	205	202	200	198	196	194	192	189	187	186	184	182	90	

## Useful technical hints

### Jammed lock

Free move; Lock  $\frac{GX}{GX}$

Remove the strippers and feeding eyelet.  
Carefully free the lock.  
Remember to check the number on the row counter if you unravel a few rows of the knitting.

The jamming of the lock may be caused by:

- an incorrect setting of the lock
- use of the wrong strippers
- the absence of strippers
- an uneven flow of the yarn.

### Dropped stitches

Since the DUOMATIC 80 works without weights, any dropped stitches will not run, and are best crocheted up with the aid of a crochet hook once the work is finished.

Dropped stitches may be due to:

- an overlarge stitch size
- a damaged latch needle.

### Loops forming at the edges

These may occur if the setting is too low on the yarn brake.

If so, increase the setting to a higher number.

### Too tight or unknitted edge stitches

These may be due to the yarn brake setting being too high. If so, decrease the setting to a lower number.

### Pushers in wrong position

- A pusher may have become stuck in the upper part of the blocking rail.
- The pushers may be clogged by dust interfering with their free movement. In this case they simply need a good clean, page 87.
- The lock has not been taken far enough past the end of the knitting (approx. 10 cm / 4").

### Replacing a needle

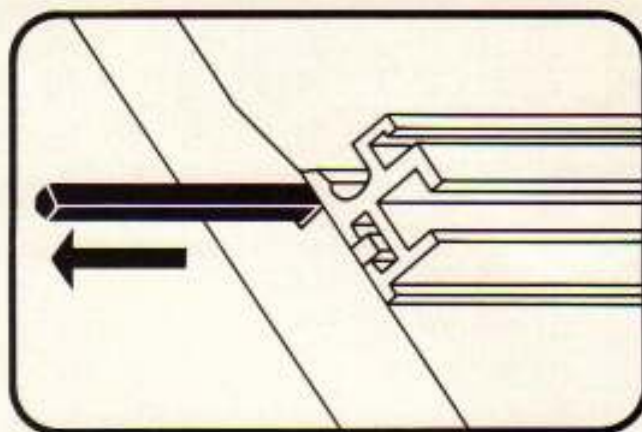

- Pull out the needle rail, which is situated below the upper rail, until the defective needle is cleared. To grip the needle rail properly, push it from the one side until it projects sufficiently from the other side. On the back bed, however, the needle rail can only be pushed out after removing the two-colour changer first.
- If either the needle head or the latch are damaged, **they must first be broken off with a pair of flat pliers to avoid any damage to the retaining spring.**

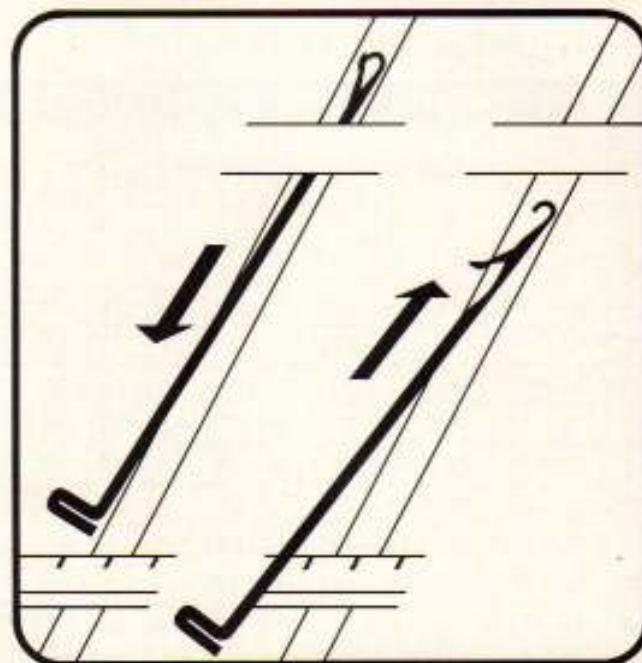

- Now hold the needle by its foot and remove it from the needle channel. But unless you have removed the head of the needle, it is absolutely essential **to close the latch.**
- Insert the new needle, **with its latch open**, from below, into the needle channel.
- Finally, return the needle rail to its proper place.

## Damaged yarn

This may be due to a damaged black stripper blade. See illustration on how to replace it.

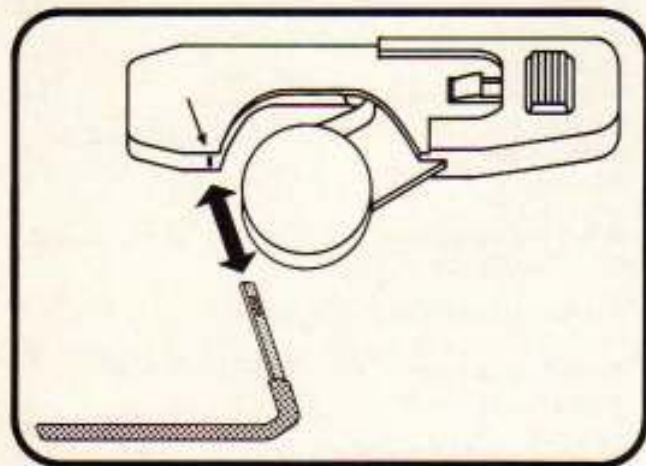

## How to clean the DUOMATIC 80

Clean and oil the machine only after having removed the knitting.

A machine not in use should never be left uncovered. Always protect it against dust with the cover.

### Cleaning

Every time a garment is finished, or daily if the machine is in constant use, proceed as follows:

1. With a soft, dry cloth wipe off all surplus oil, or oil which has become black, from the lock and needle bed.
2. With a dry brush remove remaining yarn fluff from the needle bed and the interior of the lock.
3. Carefully wipe inside rails of needle bed with a cloth. Dust and oil accumulating may cause heavy movement of the lock.

Occasionally, and should the machine seem to be unduly stiff in operation (heavily accumulated with oil and fluff), additional cleaning should be carried out as follows:

### Cleaning procedure

Clean lock parts and lock guides as well as needles in the needle channels with a brush and then rub lightly with cloth, moistened with cleaning solution.

### Cleaning solution

We suggest you contact our nearest dealer for the correct solution. If this is not possible, use a mixture of 95% (approx. 1 pint) surgical spirit to 5% (approx. 1 fluid ounce) Bellodor oil.

Never use methylated spirit on its own, as it has a drying effect and might lead to rust.

**For deeper cleaning**, clean lock guides and cams with brush and cleaning solution, afterwards rub parts with cloth moistened with cleaning solution.

Remove needles from bed and rinse in cleaning solution. Then rub them with cloth dipped in cleaning solution.

Rub rails with dry cloth and then clean with brush dipped in cleaning solution.

Clean needle channels with moistened brush. With dry brush remove dust from striking comb.

Then clean with dry brush. Rub machine with dry cloth.

Reinsert needles in the bed.

### Special note:

Never use petrol / gasoline on the plastic parts of your machine. Use soapy water instead. Never rub over the letters on lock and front plate with wet cloth or brush.

### Oiling after having cleaned the machine

#### 1. Lock

Spread 3 to 4 drops of Bellodor oil on and around each of the guiding rails. Oil lock parts along which the needles slide, with brush or oily cloth.

#### 2. Guide rails

Put 2 to 3 drops of Bellodor oil on the middle part of each guide rail.

#### 3. Needles and pushers

Put needles and pushers into Working Position, then, with a brush or oily cloth lightly rub all needle and pusher feet. Move locks over machine 4–5 times.

### Special note:

Only use Bellodor oil. Other qualities of oil may contain ingredients harmful to the plastic parts of the machine.



# Alphabetical Index

	Page		Page
<b>Abbreviations</b> . . . . .	57, 76	<b>Mattress stitch</b> . . . . .	81
<b>Arrow keys</b> . . . . .	9	<b>Necklines</b> . . . . .	60, 61
<b>Basic stitch patterns</b> . . . . .	37–39	<b>Needles</b> . . . . .	12
<b>Blocking rail</b> . . . . .	13	<b>Needle beds</b> . . . . .	5
<b>Borders</b> . . . . .	37, 38	<b>Needle positions</b> . . . . .	12
<b>Bust darts</b> . . . . .	57	<b>Needles, replacing</b> . . . . .	86
<b>Buttonhole</b> . . . . .	62	<b>Needle rule</b> . . . . .	12
<b>Cable</b> . . . . .	73	<b>Needle scale</b> . . . . .	5
<b>Calculation of garments</b> . . . . .	82–85	<b>N-X lever</b> . . . . .	9
<b>Carpet stitch</b> . . . . .	68	<b>Oiling the machine</b> . . . . .	87
<b>Casting off, double-bed</b> . . . . .	47, 48	<b>One: One rib</b> . . . . .	37
<b>Casting off, single-bed</b> . . . . .	48, 49	<b>Pattern selector dial</b> . . . . .	9
<b>Casting on</b> . . . . .	42–46	<b>Pinning out to size</b> . . . . .	80
<b>Cleaning solution</b> . . . . .	87	<b>Position of needles</b> . . . . .	12
<b>Cleaning the DUOMATIC 80</b> . . . . .	87	<b>Position of pushers</b> . . . . .	13
<b>Colour changer, automatic</b> . . . . .	5, 16	<b>Pressing</b> . . . . .	80
<b>Connecting the locks</b> . . . . .	11	<b>Pushers</b> . . . . .	13
<b>Decreasing, one stitch</b> . . . . .	53	<b>Pushers in wrong position</b> . . . . .	86
<b>Decreasing, several stitches</b> . . . . .	54	<b>Racking</b> . . . . .	5, 7
<b>Diagram</b> . . . . .	11	<b>Racking handle</b> . . . . .	5
<b>Dropped stitches</b> . . . . .	86	<b>Racking indicator</b> . . . . .	7
<b>Edge loops</b> . . . . .	15, 86	<b>Releasing stitches</b> . . . . .	16
<b>Edge springs</b> . . . . .	7	<b>Replacing a needle</b> . . . . .	86
<b>Edge stitches</b> . . . . .	15, 86	<b>Row counter</b> . . . . .	7, 11
<b>Fairisle</b> . . . . .	67	<b>Seams</b> . . . . .	81
<b>Fairisle, reversible</b> . . . . .	67	<b>Slippers</b> . . . . .	24
<b>Fairisle, tubular</b> . . . . .	70	<b>Slit, vertical</b> . . . . .	60
<b>Fancy stitch patterns</b> . . . . .	63–73	<b>Socks</b> . . . . .	74
<b>Fancy tubular</b> . . . . .	68, 69	<b>Stitch by stitch, back stitching</b> . . . . .	81
<b>Feeding eyelet</b> . . . . .	11, 15, 16	<b>Stitch, edge</b> . . . . .	15, 86
<b>Fisherman's rib</b> . . . . .	38	<b>Stitch, release</b> . . . . .	16
<b>Free move</b> . . . . .	86	<b>Stitch size</b> . . . . .	9
<b>Fringes</b> . . . . .	73	<b>Stitch size regulator</b> . . . . .	9
<b>Graduations (short rows)</b> . . . . .	55–57	<b>Stocking stitch</b> . . . . .	37
<b>Graft stitch</b> . . . . .	81	<b>Strippers</b> . . . . .	9
<b>Half Fisherman's rib</b> . . . . .	38	<b>Stripper, black, replacing stripper blade</b> . . . . .	87
<b>Half tubular</b> . . . . .	39	<b>Sweater</b> . . . . .	75–79
<b>Hem</b> . . . . .	81	<b>Tension disc</b> . . . . .	15
<b>How to knit garments</b> . . . . .	17	<b>Test square</b> . . . . .	82
<b>Increasing, one stitch</b> . . . . .	50, 51	<b>Threading the yarn</b> . . . . .	14–16
<b>Increasing, several stitches</b> . . . . .	51, 52	<b>Transfer of stitches</b> . . . . .	40, 41
<b>Intarsia</b> . . . . .	59	<b>Trip cam for row counter</b> . . . . .	7
<b>Jaws for feeding eyelet</b> . . . . .	11, 16	<b>Tubular</b> . . . . .	39
<b>Knit / Knit</b> . . . . .	37	<b>Tubular fairisle</b> . . . . .	70
<b>Knitting course</b> . . . . .	17	<b>Tubular, fancy</b> . . . . .	68, 69
<b>Knob for lowering front bed</b> . . . . .	5	<b>Two colours knitted on same row</b> . . . . .	58
<b>Lock</b> . . . . .	8–11	<b>Two:Two rib</b> . . . . .	38
<b>Lock, empty, to release stitches</b> . . . . .	16	<b>U 70, pattern with</b> . . . . .	71
<b>Long stitch</b> . . . . .	39	<b>Waxing the yarn</b> . . . . .	14
<b>Loops at the edge</b> . . . . .	15, 86	<b>Winding the yarn</b> . . . . .	14
<b>Lowering the front bed</b> . . . . .	5	<b>Yarn guide</b> . . . . .	14, 15
		<b>Yarn, damaged</b> . . . . .	87

# PASSAP<sup>®</sup> duomatic 80



**PASSAP<sup>®</sup>**

MADAG Maschinen- und Apparatebau Dietikon AG  
CH-8953 DIETIKON/Schweiz-Suisse-Suiza-Switzerland

33.253.91 englisch

