

Service Manual for

brother

MODEL KH-260



INDEX

TABLE FOR TROUBLE SHOOTING	1
CONSTRUCTION AND OPERATION OF KNITTING MACHINE	3
KH-260 NEEDLE SELECTING MECHANISM	5
DISASSEMBLING THE CARRIAGE	10
ASSEMBLING THE CARRIAGE	16
CHECKING THE CARRIAGE FUNCTIONS	22
HOW TO ADJUST THE CARRIAGE	24
DISASSEMBLING THE MACHINE BODY	28
ASSEMBLING THE MACHINE BODY	34
CHECKING THE MACHINE BODY	41
HOW TO ADJUST THE MACHINE BODY	42

SPECIFICATIONS

Pitch of stitches	9 mm
No. of needles	114 needles
No. of selected needles	24 needles
Needle selection	punch card
Patterning function	Fair-isle pattern, Thread-lace pattern, Skip pattern, Tuck pattern, Weaving pattern, Plating Yarn knitting, Plating Tuck pattern
Patterning variation	Double length, Single motif
End needle selection mechanism	automatic
Knit leader	available optionally (KL-116)
Weight	15.6 kg

TABLE FOR TROUBLE SHOOTING

Trouble		Cause	Remedy	Note
Carriage	Does not move easily.	<ol style="list-style-type: none"> Sliding part of carriage cam is out of oil. Sliding part of needle bed is out of oil. Sinker plate is in contact with gate pegs. Gauge is too tight. 	<ol style="list-style-type: none"> Oil needle butt and stitch cam. Oil front and rear rails of body and carriage. Adjust sinker plate position. Loosen knitting gauge. 	See Instruction Manual.
Knitting	Floating stitches. Stitches get tucked.	<ol style="list-style-type: none"> Too much gap between sinker plate and comb teeth. Poor operation of needle latch. Too fine gauge. 	<ol style="list-style-type: none"> Adjust sinker plate position. Replace needle. Widen gauge. 	See Instruction Manual.
	Lateral stripes are produced here and there; not knitted neatly.	<ol style="list-style-type: none"> Variation of carriage operating speed. Poor yarn supply. 	<ol style="list-style-type: none"> Operate carriage at constant speed. Lessen tension spring pressure. 	See Instruction Manual.
	Knitted differently on right and left sides.	<ol style="list-style-type: none"> Gate pegs installed differently. 	<ol style="list-style-type: none"> Install right and left gate pegs in the same way. 	
	Carriage sticks midway.	<ol style="list-style-type: none"> Needle bed is damaged. Plain needle is bent and needle butt is damaged. Guide cam A is installed wrongly. 	<ol style="list-style-type: none"> Repair needle bed. Replace needle. Adjust guide cam position. 	
Machine Body	Material knitted longer than the dimension specified by drawing.	<ol style="list-style-type: none"> Poor measurement with knitting gauge. Wrong measures against mistakes made in the middle of operation. 	<ol style="list-style-type: none"> Measure properly with the gauge. Take proper measures with knit-leader sheet. 	See Instruction Manual.
	The same needle does not come out.	<ol style="list-style-type: none"> Plain needle is bent. Card reader and rotary cam are not in the right relative position. 	<ol style="list-style-type: none"> Replace needle. Adjust the rotary cam position. 	
	Unnecessary needle comes out every six cycles.	<ol style="list-style-type: none"> Grease sticks between needle selector plates. N.S.P. operation lever does not move easily as squeezed between operation lever presser and card reader guide. Operation lever presser presses needle selector plate. Needle bend or breakage. 	<ol style="list-style-type: none"> Wipe away the grease. Replace the needle selection unit. Adjust operation lever presser position. Replace needle. 	

CONSTRUCTION AND OPERATION OF KNITTING MACHINE

To know about a knitting machine, it is necessary to understand the principle of operation through knowledge about the mechanism and function of each part.

If you understand the principle, you can easily find particular cause of trouble, if occurred, to carry out repair work. You can also give explanation and understanding of the knitting machine to customers.

CARRIAGE:

1. Stitch cam and raising cam

1.1 Stitch cam

The stitch cam moves the plain needles back and forth, thus making stitches.

1.2 Raising cam

The raising cam changes the route of the plain needles at B position.

2. Cam button

The cam button is used for pattern knitting. By the selection among six position, the cam is changed to alter the route of plain needles; tuck (right or left), MC, thread-lace, and skip (right or left).

3. Holding cam lever (H.C.L.)

The holding cam lever changes the route of plain needles at E position.

4. Tension dial

The tension dial changes the position of the stitch cam back and forth for making stitches rough and fine.

5. Change knob

The change knob has four positions of (N) "plain stitch," (KC) "pattern stitch," (SM) "single motif," and (CR) "carriage release." It functions as follows:

5.1 Plain stitch "(N) position"

The plain knitting is performed with this position set. Needle selection is not performed even if punch cards are set.

5.2 Pattern stitch "(KC) position"

When the change knob is set to this position, the pattern knitting is performed with punch cards, needle are selected corresponding to the punched holes on the card.

5.3 Single motif "(SM) position"

Twenty-four needles having the single-motif cam are selected with the cam when set to this position.

5.4 Carriage release "(CR) position"

The carriage can be released for removal from the machine body when set to this position.

6. Selection cam

When the change knob is set to (KC) "pattern stitch" position, the needle selection change cam is lowered, thus letting the plain needles at B and D positions through the selection cams to press the plain needles.

7. Tuck cam

The tuck cams are used to reduce the length of upward thrust of the needles at B position and hook the next yarn without pulling off the latches or with the stitches of the previous row hooked.

8. Separation cam

Some plain needles pressed by the selection cams are caught and hooked by the needle selector plates (needles lowered down into the needle bed) and some are not (needles raised upward) while the needle selector plates move according to the punch cards. These needles, lowered or raised, are separated to B or D position by the height of the separation cams.

9. Yarn feeder

There are three types of yarn feeder; main yarn feeder, yarn feeder B (for fair-isle pattern), and plating yarn feeder. The main yarn feeder guides and supply the yarn to the hooks of plain needles which are raised by the stitch cams, or raised by the MC stitch cams in the case of yarn feeder B. And it also protects the needles latches.

10. Sinker plate

The sinker plates prevent knitted material from coming up as caught by the plain needles which are raised by the cams.

MACHINE BODY

1. Needle bed

The needle bed guides the back and forth movement of the needle and determines the pitch of stitches.

2. Gate peg

The gate peg form the sinker loops of stitches and also make the stitches even.

3. Plain needle

The plain needles are moved back and forth by the carriage cams to form needle loops.

4. Belt

When the carriage is moved to select needles with the card, the belt turns to drive the needle selecting mechanism and also synchronizes the timing of the needle selecting mechanism to the carriage movement.

5. Needle selector plate

The needle selector plates holder assembly consist of six needle selector plates of the same design as set off by one pitch. The needle selector plate which corresponds to the holes on the punch card is moved to the right and its hooks catch the shunks of the plain needles.

6. Clutch wheel

The clutch wheel operates the needle selector mechanism and feeds the punch card by one pitch.

7. Rotary cam

The rotary cam has lobes spaced and shifted by $\frac{1}{4}$ pitch around its circumference. It pushes the card readers, which correspond to the punched holes, to the left by utilizing rotary movement transmitted with the belt.

8. Card feeding cam

The card feeding cam is turned half by the rotary movement transmitted by the belt and the clutch wheel, so that the card feeding lever roller ascends over the cam lobe to move the card feeding lever up and down.

9. Card reader release cam

When the card reader release cam is turned half by the rotary movement transmitted by the belt and the clutch wheel, the card reader release plate roller ascends over the cam lobe to push down the card readers.

KH-260 NEEDLE SELECTING MECHANISM

★ The needle selecting mechanism of the model KH-260 is explained as follows. When the needle is moved downward by the needle selection cam of the carriage, the card reader which corresponds to the punched hole is moved up and then pressed to the left by the turn of the rotary cam. And the N.S.P. operation lever, as interlocked with the card reader, is moved to shift the needle selector plate to the right. Then the hook of the needle selector plate catches the needle shank to keep the plain needle down. While kept in this condition, the plain needle is selected to D position by the separation cam of the carriage.

With regard to the plain needle which corresponds to the unpunched position of the card, the card reader is not moved up and the needle selector plate is not moved, either. Therefore the plain needle returns soon, even if pressed down by the selection cam, to push itself back to B position by the separation cam.

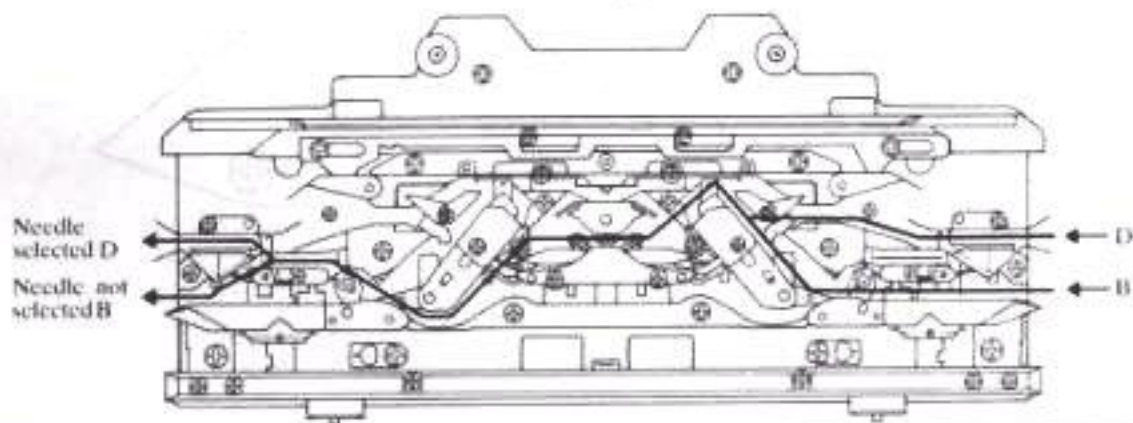
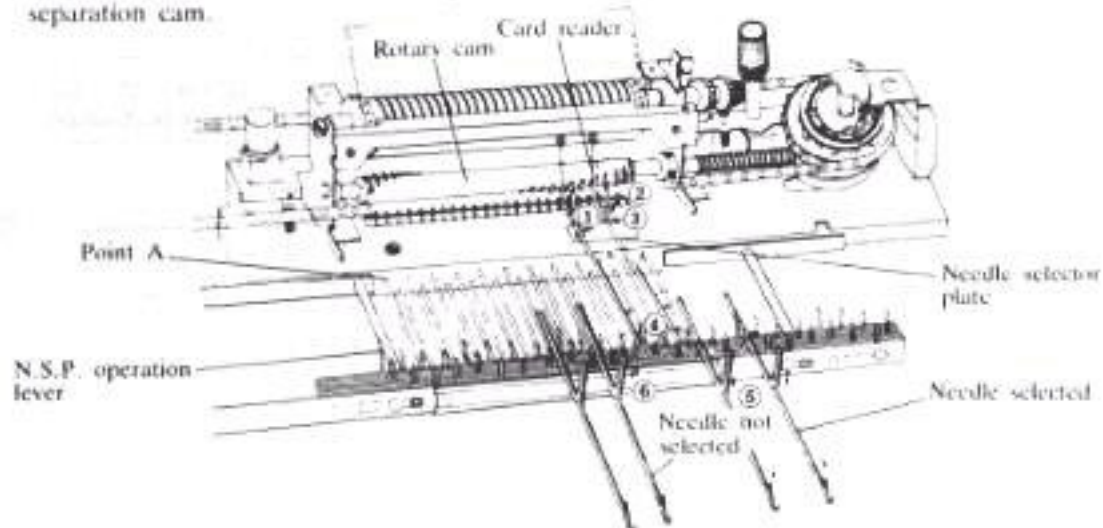

(Machine Body)

- ① The card reader, which corresponds to the punched hole, is raised up by the spring.
- ② The card reader is pressed to the left by the rotary cam.
- ③ The N.S.P. operation lever is moved to the left as pushed by the card reader.
- ④ The N.S.P. operation lever on the needle selector plate side pivots upon A point to the right.
- ⑤ The needle selector plate of that position is moved to the right until it catches the needle shank, thus keeping the needle down.
- ⑥ The needle selector plate, which corresponds to the unpunched position of the card, is not moved. Therefore the plain needle, even if lowered, returns up soon.

(Carriage)

Because the plain needle corresponding to the punched hole is lowered down by the needle selector plate, it passes the separation cam to carry out the needle selection to D position. Because the needle corresponding to the unpunched position returns soon, even if moved down, it functions at A point of the separation cam to move back to B position.

1. Single motif mechanism

① (Before the carriage goes through the S.M. cam)

Because the pin stays still before it comes up to the S.M. cam, the S.M. cam change lever does not function, so that the needle selection change cam does not move upward. Therefore the plain needles do not pass the selection cam and no needle selection is performed.

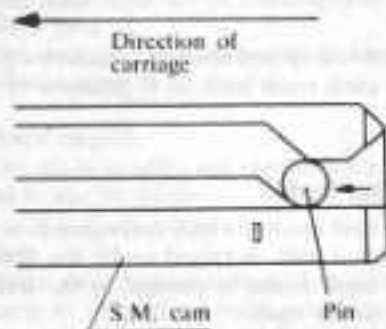

② (While passing the S.M. cam) (Single motif needle selection)

When the pin comes over the lobe of the S.M. cam, the needle selection change cam is forced upward by the S.M. cam change lever which interlocks with the S.M. cam. As a result, the plain needles pass the selection cam to carry out the needle selection according to the design specified by the punch card.

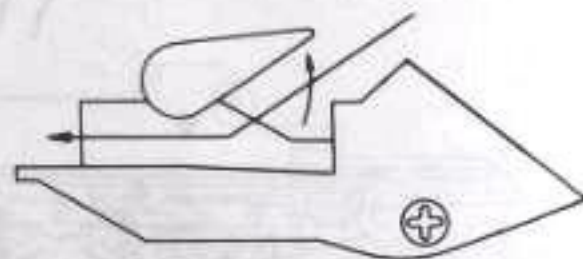
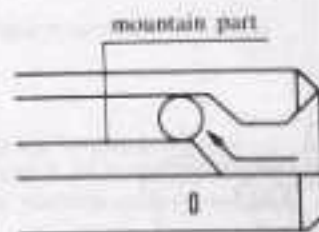

2. End needle selection mechanism

(1) Entry side

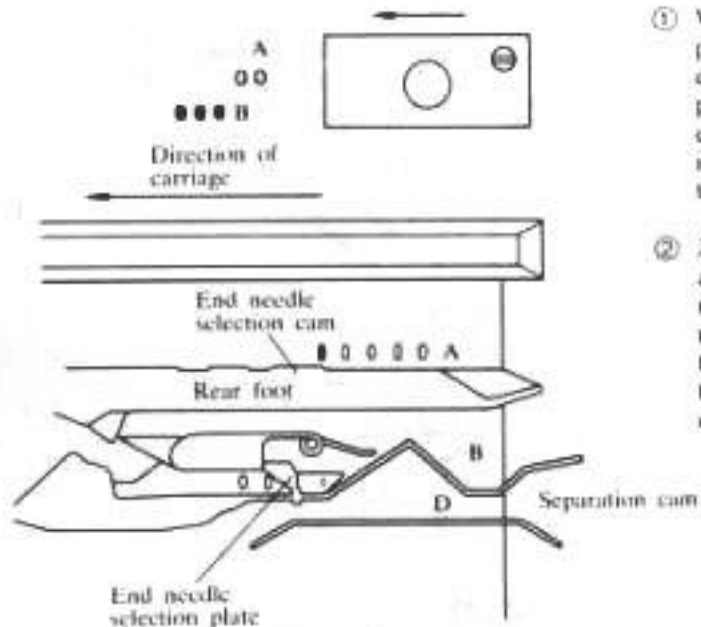

① While the carriage passes the plain needles at A position, the end needle selection cam is pressed down by the butt of each plain needle to keep the interlocked end needle selection plate pushed forward.

② Just before the last plain needle at A position comes off the end needle selection cam, the end needle at B position is let over the separation cam then fed to the route of D position by the end needle selection plate.

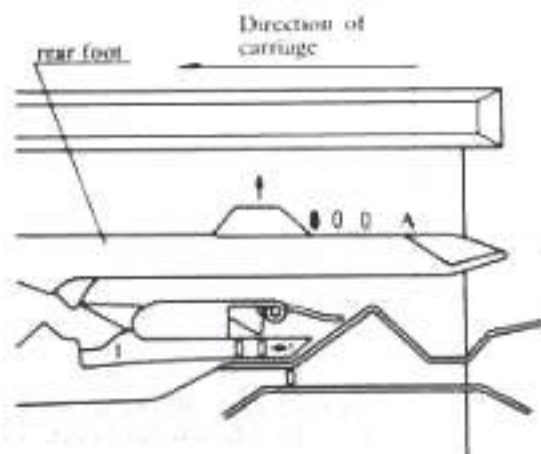

③ When the last plain needle at A position actually comes off the end needle selection cam, the end needle selection cam returns upward and the end needle selection plate also returns to its home position. Therefore the needles after the second one at B position take the normal-way to carry out the needle selection according to the design specified by the punch card.

(1) Exit side

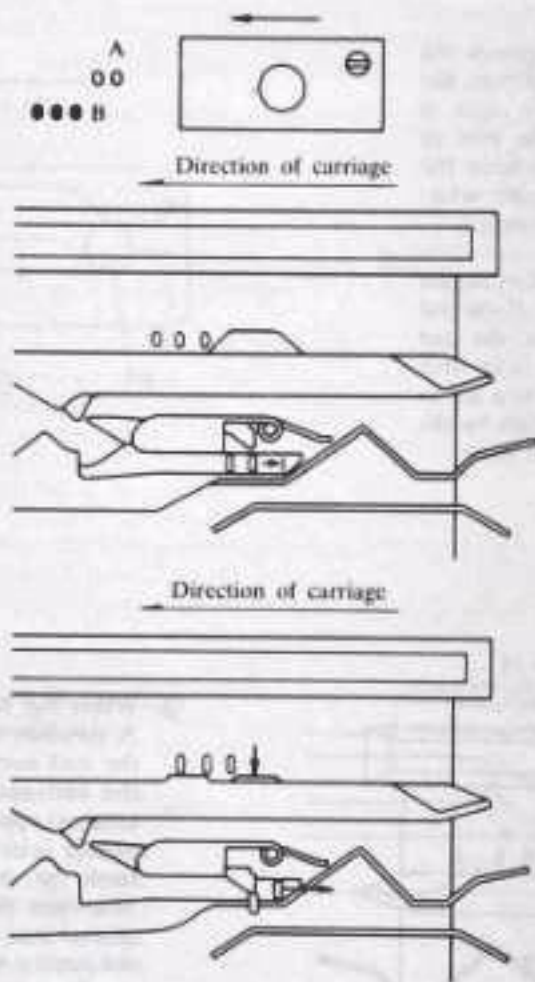

① While the carriage passes the needles at B or D position, the end needle selection cam is kept upward and the plain needles take the normal way.

② When the first needle at A position is caught and pushed by the end needle selection cam, the end needle at B position is let over the separation cam and fed to D route by the interlocked end needle selection plate.

(Note) This automatic end needle selection is carried out automatically when the change knob is set to (KC) "pattern stitch" position. Therefore, when you knit open stitch patterns, it is necessary to release the end needle selection mechanism by switching end needle selection switch cam to select no end needles at "A" position.

3. Cam button auto reset mechanism

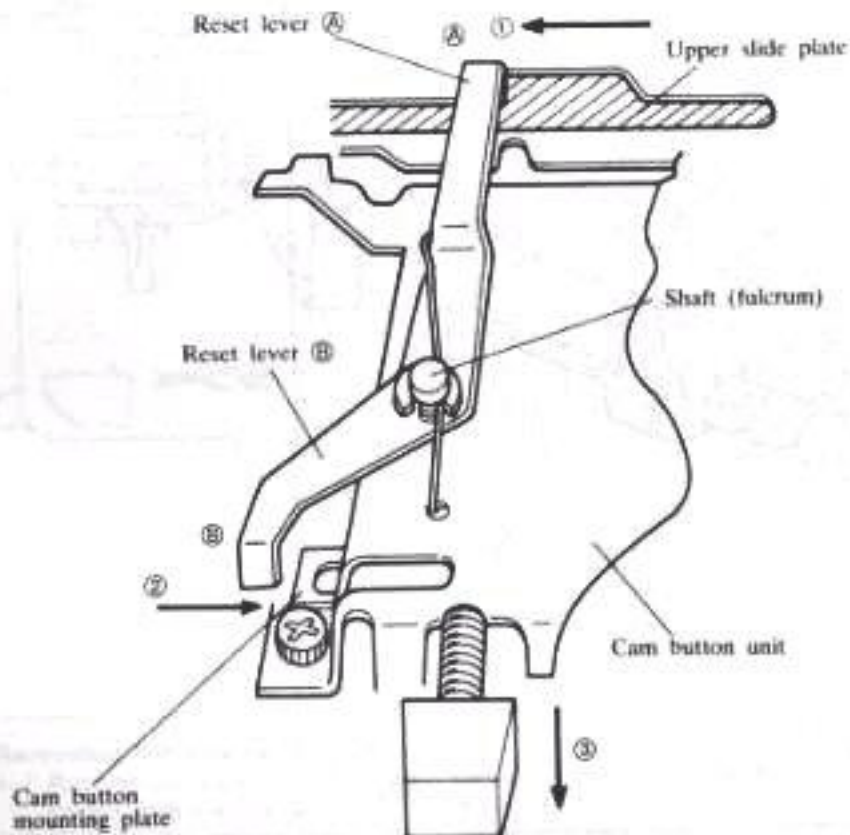

When the change knob is set to (NL) "plain stitch" position from (KC) "pattern stitch" or (SM) "single motif" position;

- ① The Reset lever ① is moved to the left by the upper slide plate
- ② The Reset lever ② pivots to the right upon the shaft to push the cam button mounting plate
- ③ The locked cam button is released and returned automatically.

DISASSEMBLING THE CARRIAGE

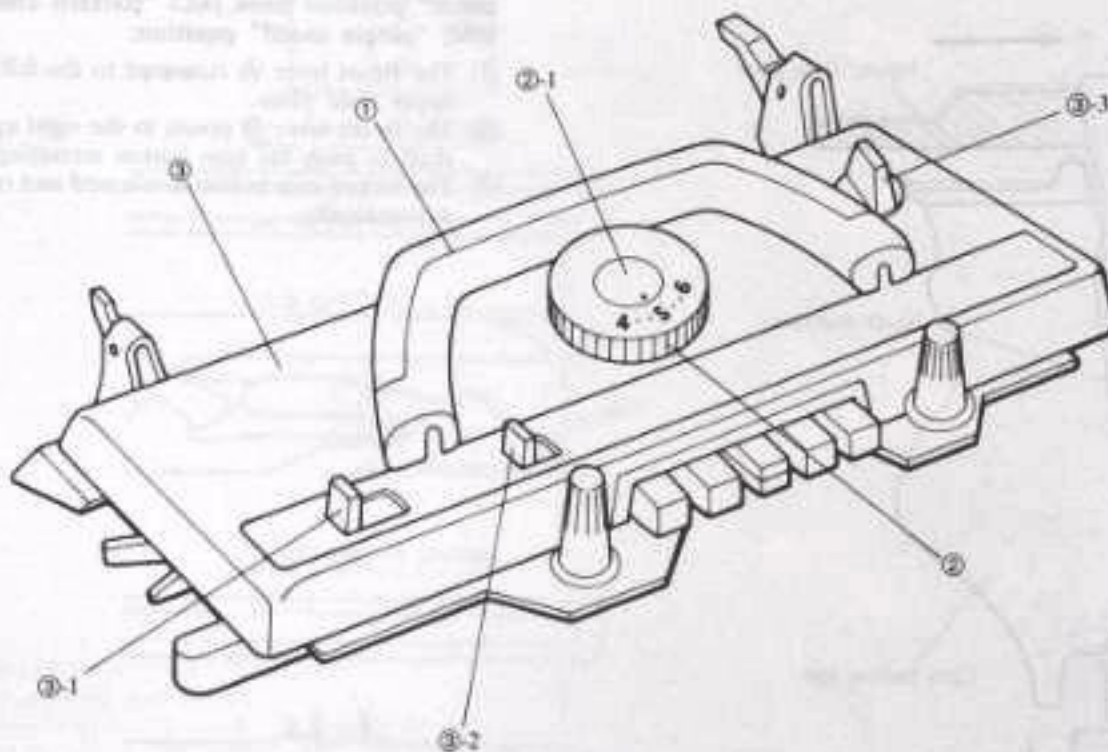

Names of Parts

- ① Handle
- ② Stitch dial
- ②-1 Stitch dial cap
- ③ Carriage cover
- ③-1 H.L.C. knob
- ③-2 Plain lever knob
- ③-3 Change knob

(Fig. 1)

1. Removing the carriage handle

- 1.1 Remove both handle screws on right and left sides while keeping the handle down. Then the handle can be taken off the carriage.

2. Removing the stitch dial

- 2.1 Pull off the stitch dial cap upward.
- 2.2 Remove the fastening screw and pull off the stitch dial upward.

3. Removing the carriage cover

- 3.1 Loosen and remove both right and left carriage cover clamp screws from the bottom of the carriage. (See Fig. 4)
- 3.2 Remove carriage cover upward. Then the H.C.L. knob, the plain lever knob and the change knob, will come off.

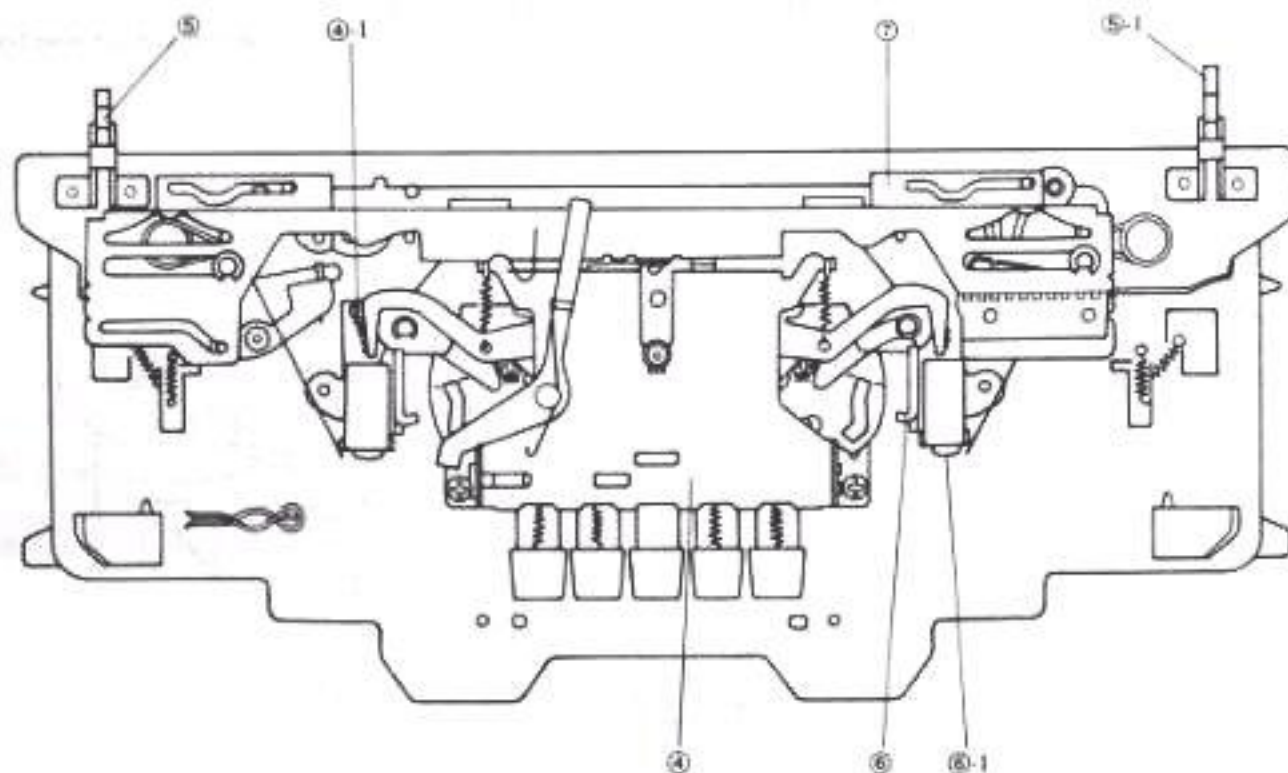

(Fig. 2)

Names of Parts

- ④ Cam button unit
- ④-1 Raising cam change spring
- ⑤ Knit leader tripper
- ⑤-1 Row counter tripper
- ⑥ Handle setting base
- ⑥-1 \times -screw 3.57 x 4
(For handle lock spring)
- ⑦ Upper slide plate assembly

4. Removing the cam button unit

- 4.1 Remove the right and left raising cam change springs from the raising cam calking pins with the work books.
- 4.2 Remove two screws which clamp the cam button unit.
- 4.3 Remove the cam button unit by pulling it forward and lifting it up.

5. Removing the knit leader tripper and the row counter tripper

- 5.1 Remove each two screws clamping the knit leader tripper and the row counter tripper from the bottom of the carriage.

6. Removing the handle setting base

- 6.1 Loosen the right and left screws to remove both handle lock springs.
- 6.2 Remove screws on both sides to detach the handle setting base.

7. Removing the upper slide plate

- 7.1 Remove the snap rings for the change knob shaft and the carriage calking shaft which is located on the left side with a slotted screwdriver.
- 7.2 Remove the upper slide plate by lifting up its both sides simultaneously.

8. Removing the S.M. cam change crank

- 8.1 Pull up and remove the right and left S.M. cam change cranks.
- 8.2 Remove the right and left needle selection change lever springs from the carriage rear plate.

9. Removing the connecting plate spring

- 9.1 Pull up and remove the right and left connecting plate spring.

10. Removing the rear plate

- 10.1 Pull up and remove the rear plate.

11. Removing the tuck cam operating plate

- 11.1 Remove two tuck cam springs from calking pins.
- 11.2 Pull up and remove the presser ring and the right and left tuck cam operating plates.

12. Removing the change plate A and B

- 12.1 Remove the right and left MC cam springs from the pin.
- 12.2 Remove the change plate spring from the change plate.
- 12.3 Remove the change plate A spring from the change plate.
- 12.4 Remove the change plate B spring.
- 12.5 Remove the nut of change plate guide collar with a 6 m/m box driver to detach the change plate guide collar.
- 12.6 Pull up and remove the change plate A and B.

13. Removing the push-up change plate

- 13.1 Remove the screws of push-up change plates, right and left, and also the collars placed under them.
- 13.2 Pull up and remove both push-up change plates.

14. Removing the cam change plate

- 14.1 Remove the valve cam E springs from the carriage calking pin and the valve cam E.
- 14.2 Remove the right and left cam change plates by loosening and removing their nuts.

15. Removing the valve cam F spring

- 15.1 Remove both valve cam F springs from the selection guide for right and left end needles.

16. Removing the S.M. cam lever

- 16.1 Remove both nuts from the S.M. cam levers with a 8 m/m box drivers.
- 16.2 Then S.M. cam levers come off.

Names of Parts

- ⑧ S.M. cam change crank
- ⑧-2 Needle selection change lever spring
- ⑨ Connecting plate spring
- ⑩ Rear plate
- ⑪ Tuck cam operating plate
- ⑫ Change plate A (upper)/ Change plate B (lower)
- ⑫-2 Change plate spring
- ⑫-3 Change plate A spring
- ⑫-4 Change plate B spring
- ⑬ Push-up change plate
- ⑬-1 Push-up change plate clamp screw & collar
- ⑭ Can change plate
- ⑭-1 Valve cam E spring
- ⑭-2 End needle selection cam spring
- ⑮ Valve cam F spring
- ⑯ S.M. cam lever

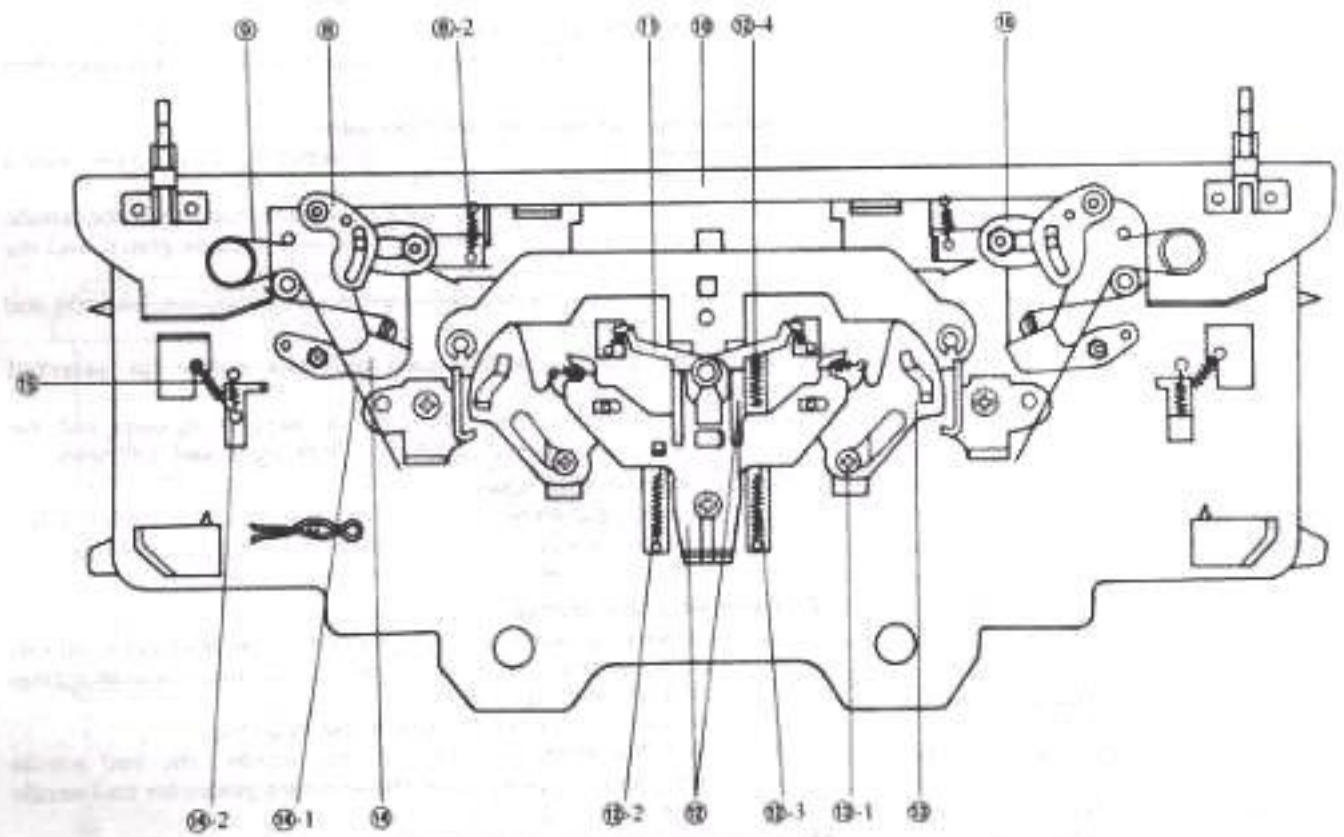

(Fig. 3)

17. Removing the front slide plate

- 17.1 Remove the right and left screws to pull up and remove the front slide plate, then the holding cam springs come off the front side.
(Be sure to set the H.C.L. knob to H position when pulling up the plate.)

18. Removing the carriage front leg

- 18.1 Remove two screws to detach the carriage front leg.

19. Removing the guide cam A

- 19.1 Remove the right and left screws to detach the guide cam A, and the slide cam comes off.

20. Removing the slide guide cam assembly.

- 20.1 Remove the slide guide cam assembly by loosening two clamp screws.

21. Removing the push-up cam

- 21.1 Remove the right and left screws, which clamp the push-up cam, from the front side of carriage.
21.2 Then the push-up cams and the push-up cam holder plates come off.

22. Removing the MC guide cam

- 22.1 Remove both screws on right and left sides, then the MC guide cams, the MC guide change cams, and the shafts come off.

23. Removing the thread-lace change plate

- 23.1 Remove two screws of the fastening plate for thread-lace change plate.
23.2 Loosen two screws of the rear foot.
23.3 Pull up and remove the thread-lace change plate.

24. Removing the stitch cam

- 24.1 Remove the right and left snap rings of the stitch cam shafts from the front side of the carriage.
24.2 Remove both nuts of sub stitch cams from the front side of the carriage with a box driver.
24.3 Remove the screw of the stitch cam (left), then the sub stitch cam (left), the stitch cam (left), the valve cam D (left), the valve cam D spring (left), the sub stitch cam shaft (collar), and the screw itself come off.
24.4 Remove the right stitch cam in the same way.

25. Removing the valve cam A

- 25.1 Remove both right and left valve cam As by removing the screws on the each sides.

26. Removing the MC cam

- 26.1 Remove both right and left MC cams by removing the screws on the each sides.

27. Removing the stitch cam guide plate

- 27.1 Remove the snap rings and the washers from the shaft to detach the stitch cam guide plate.

28. Removing the guide cam F

- 28.1 Remove both right and left guide cam Fs by detaching their screws.

29. Removing the needle selection cam

- 29.1 Remove the guide cam Gs by detaching their screws with a small Phillips screwdriver.
29.2 Remove the screws of needle selection cam, then the needle selection cams, the needle selection cam guide plates, and the needle selection change cams come off.
29.3 And remove the needle selection change spacers (collars) and the valve cam Fs.

30. Removing the separation cam and the buffer for selected needle

- 30.1 Remove the screws to detach the separation cams and the buffers for selected needle on both right and left sides.

31. Removing the tuck cam

- 31.1 Remove the screws of tuck cam on both right and left sides, then the tuck cam plate, the right and left tuck cams, the tuck cam spring, and the tuck cam shafts come off.

32. Removing the carriage rear foot

- 32.1 Remove the selection guides for end needle from the front side of the carriage and remove the end needle selection springs from the carriage plate.
32.2 Remove six screws to detach the rear foot.
32.3 And the selection cams for end needle, the end needle selection cam springs, and the selection guides for end needle come off.

33. Removing the connecting plate

- 33.1 Remove both right and left connecting plates by pulling up the front foot side.

34. Removing the needle selection change plate

- 34.1 Remove the clamp screws of needle selection change plates
34.2 Remove the shafts for needle selection change cam.
(See Parts Catalogue, part no. 155 on page 3.)

Names of Parts

- ① Front side plate
- ② Front foot
- ③ Guide cam A
- ④ Slide guide cam
- ⑤ Push-up cam
- ⑥ MC guide cam
- ⑦ Thread-lace change plate
- ⑧-1 Fastening plate for thread-lace change plate
- ⑧ Stich cam
- ⑨ Valve cam A
- ⑩ MC cam
- ⑪ Washer
- ⑫ Guide cam F
- ⑬ Needle selection cam guide plate (upper)
- ⑭ Needle selection cam (lower)
- ⑮-1 Guide cam G
- ⑮-2 Valve cam F
- ⑯ Separation cam
- ⑰ Tuck cam
- ⑱ Rear foot
- ⑲ Connecting plate
- ⑳ Needle selection change plate clamp screw

(Fig. 4)

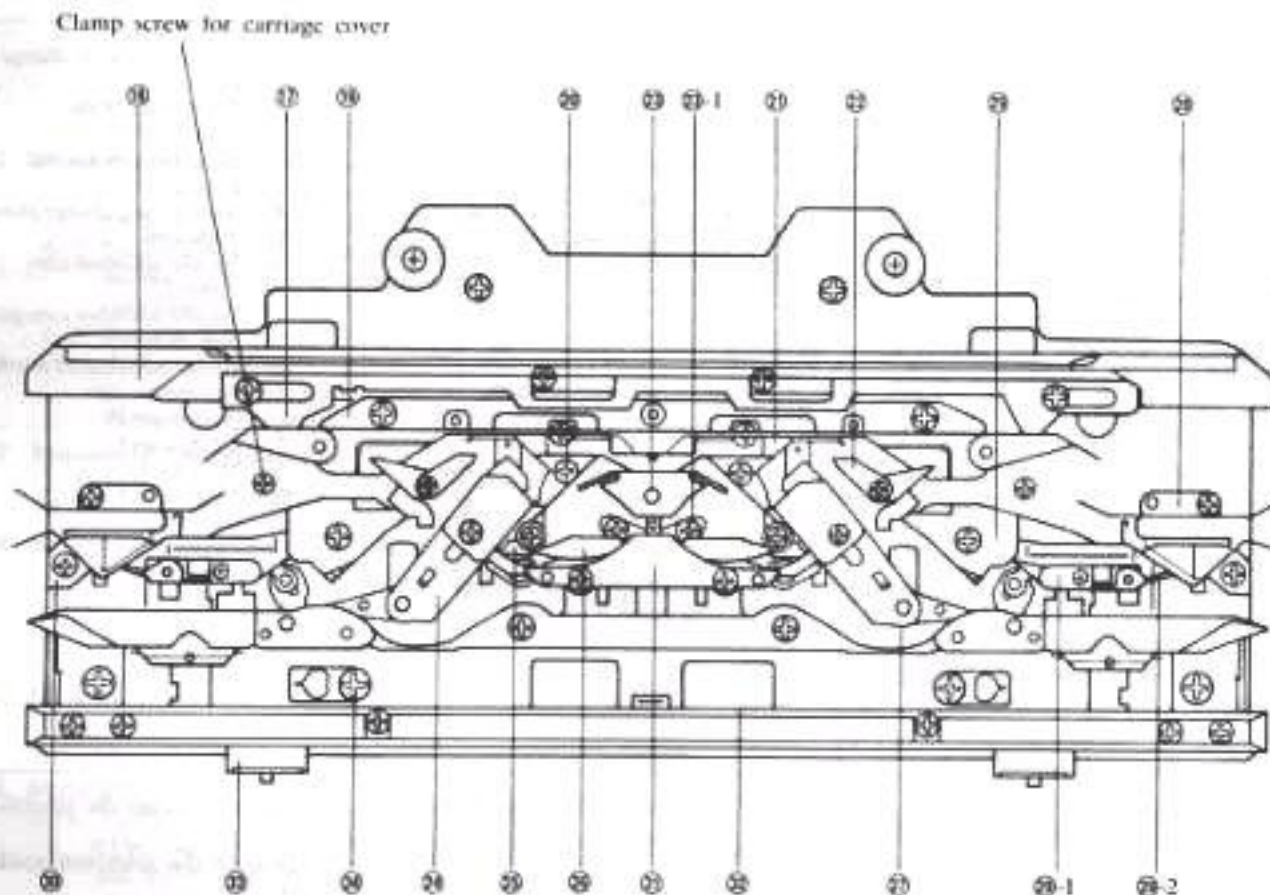

ASSEMBLING THE CARRIAGE

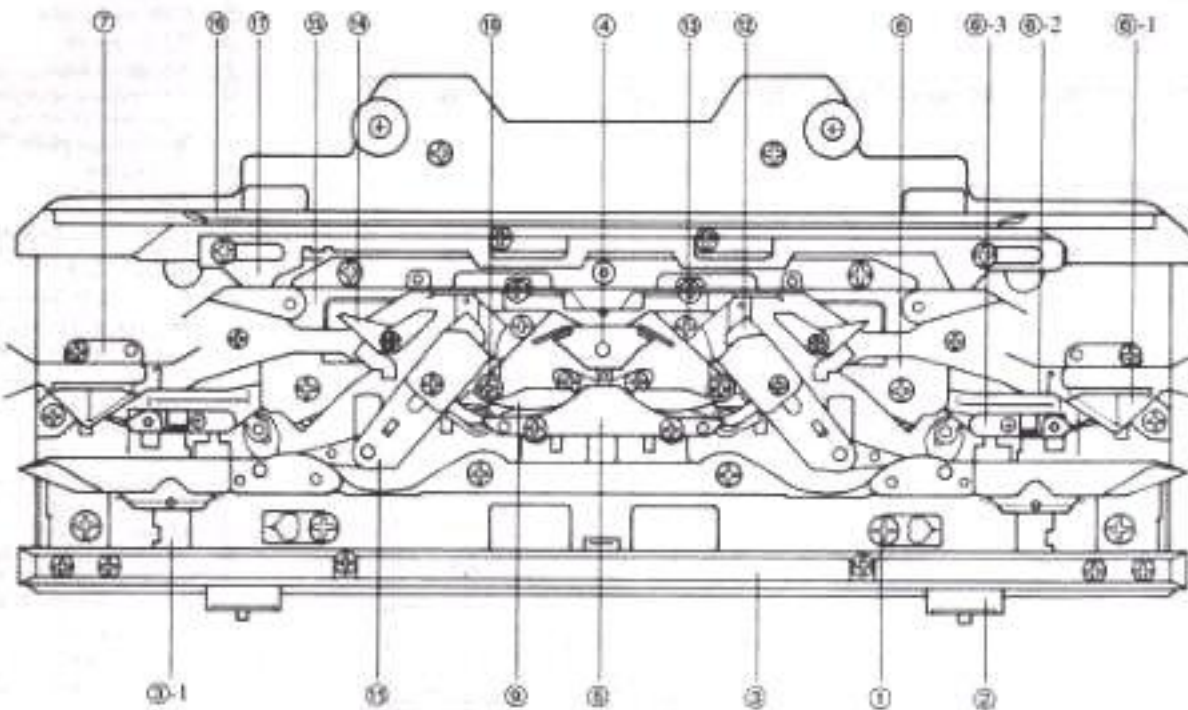

Names of Parts

- ① Needle selection change plate
- ② Connecting plate
- ③ Rear foot
- ④-1 Selection cam for end needle
- ④ Thread-lace change plate
- ⑤ Tuck cam
- ⑥ Needle selection cam (lower)
- ⑥-1 Needle selection cam guide plate (upper)
- ⑥-2 Buffer for selected needle
- ⑥-3 Separation cam
- ⑦ Guide cam G
- ⑧ Guide cam F
- ⑨ MC cam
- ⑩ Valve cam A
- ⑪ Stitch cam
- ⑫ Push-up cam
- ⑬ Side guide cam
- ⑭ MC guide cam
- ⑮ Guide cam A
- ⑯ Front foot
- ⑰ Front side plate

(Fig. 5)

1. Mounting the needle selection change plate

1.1 Mount the needle selection change plates and clamp them with screws.

2. Mounting the connecting plate

2.1 Fit the connecting plates on the carriage plate.
(Take care not to confuse the right connecting plate with the left one.)

3. Mounting the rear foot

3.1 Mount both right and left selection guides for end needle onto the carriage plate. Clamp the rear foot with screws after putting the

right and left selection cams for end needle, end needle selection switch cams, and spring onto it.

3.2 Hook the end needle selection springs over the selection guides for end needle and the carriage plate.

4. Mounting the thread-lace change plate

4.1 Put the thread-lace change plate between the carriage plate and the rear foot.

4.2 Clamp the fastening plate for thread-lace change plate with screws.

(Be sure to check the thread-lace change plate moves smoothly.)

5. Mounting the tuck cam

- 5.1 Let the right and left screws through holes of the tuck cam plate and put the right and left tuck cams, shafts for tuck cams and the tuck cam spring; take care of the proper direction of the tuck cam spring. Then clamp the tuck cam assembly onto the carriage plate with screws.
(These tuck cams should be kept open, and should be returned to their home position by the spring pressure when they are pressed and released.)

6. Mounting the needle selection cam and the separation cam

- 6.1 Fit both buffers for selected needle into the square holes of the carriage plate.
- 6.2 Put each separation cam and needle selection cam together and mount each needle selection cam guide plate onto needle selection cams. Fix them respectively with screws.
- 6.3 Put the valve cam Fs, the needle selection change spacers (collars), the needle selection change cams, and the guide cam Gs in this order. Then assemble them with screws and a small Phillips screwdriver.

7. Mounting the guide cam F

- 7.1 Mount the left guide cam F and fix it with a screw.
- 7.2 Mount the right guide cam F in the same way.

8. Mounting the stitch cam guide plate

- 8.1 Mount the stitch cam guide plate from the front side of the carriage. Then put washers to the right and left shafts of the stitch cam guide plate from the bottom side of the carriage and fix them with snap rings.

9. Mounting the MC cam

- 9.1 Tighten the screws of MC cams.
(Be sure to check these MC cams move lightly.)

10. Mounting the valve cam A

- 10.1 Tighten the screws of valve cam As.
(The valve cam A should be moved lightly by the pressure of the valve cam D spring.)

11. Mounting the stitch cam

- 11.1 Mount the left sub stitch cam shaft (collar), valve cam D spring, valve cam D, stitch cam, and sub stitch cam in this order onto the carriage plate. Assemble them with a screw and fix them with a nut from the front side of the carriage.
(Be sure to set the valve cam D spring properly so that its straight end may be placed over the bent part of the valve cam D and its curved end over the valve cam A.)

- 11.2 Assemble and mount the right stitch cam in the same way.
- 11.3 Put the snap rings to the stitch cam shafts to fix them from the front side of the carriage
(Be sure to check the valve cam D and the stitch cam moves lightly and the valve cam D is returned to its home position by the spring pressure.)

12. Mounting the push-up cam

- 12.1 Put the push-up cam holder plates to the sliding grooves of each push-up cam. Then mount the right and left push-up cams.
- 12.2 Put both push-up cam slide plates from the front side of the carriage and fix them with screws.
(Be sure to check the push-up cams move lightly.)

13. Mounting the slide guide cam

- 13.1 Mount the slide guide cam and fix it with two screws.

14. Mounting the MC guide cam

- 14.1 Mount the shafts (collars), the MC guide change cams, the MC guide cams onto the carriage in this order and fix them with screws.
(Be sure to check the MC guide change cam moves lightly.)

15. Mounting the guide cam A

- 15.1 Mount the guide cam A and fix it with screws on its both sides while putting the slide cam into the floated part of the slide guide cam.
(Mounting dimension from rear foot is 71 mm; See How to Adjust the Carriage mentioned in this manual.)

16. Mounting the front foot

- 16.1 Tighten the two screws in the middle of the carriage front foot.

17. Mounting the front slide plate

- 17.1 Mount the front slide plate onto the front foot and fix them with both right and left stud screws of the front foot.
(Be sure to check the slide plate moves lightly and the change cams move down when the slide plate is slid to the H (Holding) position.)

18. Mounting the cam change plate

- 18.1 Mount and fix the cam change plate with nuts.
- 18.2 Hook the valve cam E springs over the carriage calking pin and the valve cam E.

19. Mounting the valve cam F spring

- 19.1 Hook the valve cam F spring over the selection guide for end needle and the valve cam F on each side.

20. Mounting the S.M. cam lever

- 20.1 Put the pin of each S.M. cam lever into the hole of needle selection change plates attached on the bottom of carriage plate. And clamp them with nuts (8 m/m).

21. Mounting the push-up change plate

- 21.1 Put the screws of push-up cam slide plates and the shafts of MC guide cams into the holes of push-up change plates. Attach the collars and fix them with screws.

22. Mounting the change plate A and B

- 22.1 Mount the change plate B and the change plate A in this order. Then put the screw (change plate guide collar) and fix them with the nut (6 m/m).
- 22.2 Hook the change plate spring to the left.
- 22.3 Hook the change plate A spring to the right.
- 22.4 Attach the change plate B spring between the change plate B and the thread-lace change plate.

23. Mounting the tuck cam operating plate

- 23.1 Put the tuck cam operating plate right, first onto the shaft of the stitch dial then put the tuck cam operating plate left and the collar over them.
- 23.2 Hook both right and left tuck cam springs over the calking pins of the tuck cams.

24. Mounting the rear plate

- 24.1 Mount the carriage rear plate and hook the change lever springs.

25. Mounting the connecting plate spring

- 25.1 Hook the right and left connecting plate springs over the calking pins of connecting plate and the shafts of change knob.

26. Mounting the S.M. cam change crank

- 26.1 Put the S.M. cam change cranks to the calking shafts on the carriage plate and to the pins of S.M. cam lever.

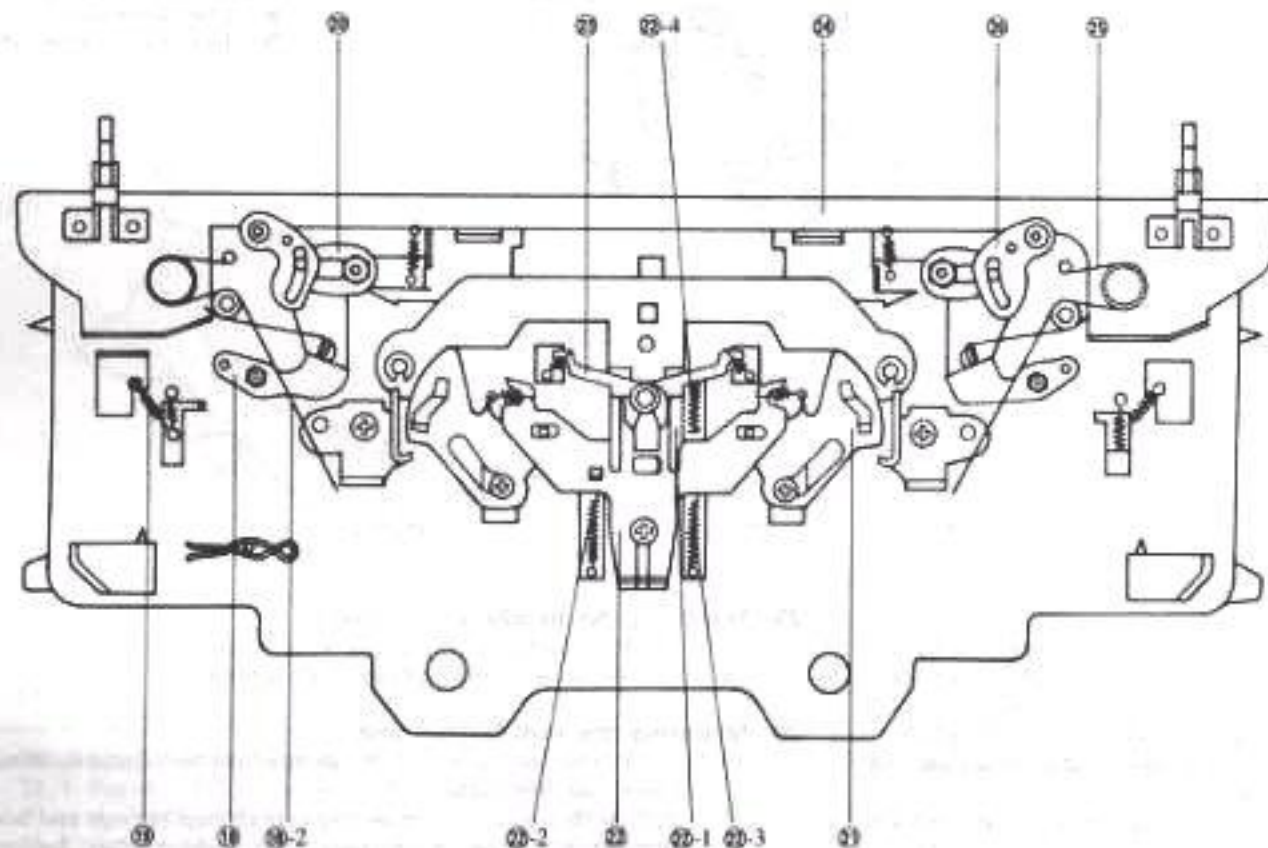

Names of Parts

- 00 Cam change plate
- 00-2 Valve cam E spring
- 00 Valve cam F spring
- 00 S.M. cam lever
- 01 Push-up change plate
- 02 Change plate A
- 02-1 Change plate B
- 02-2 Change plate spring
- 02-3 Change plate A spring
- 02-4 Change plate B spring
- 03 Tuck cam operating plate
- 04 Rear plate
- 05 Connecting plate spring
- 06 S.M. cam change crank

(Fig. 6)

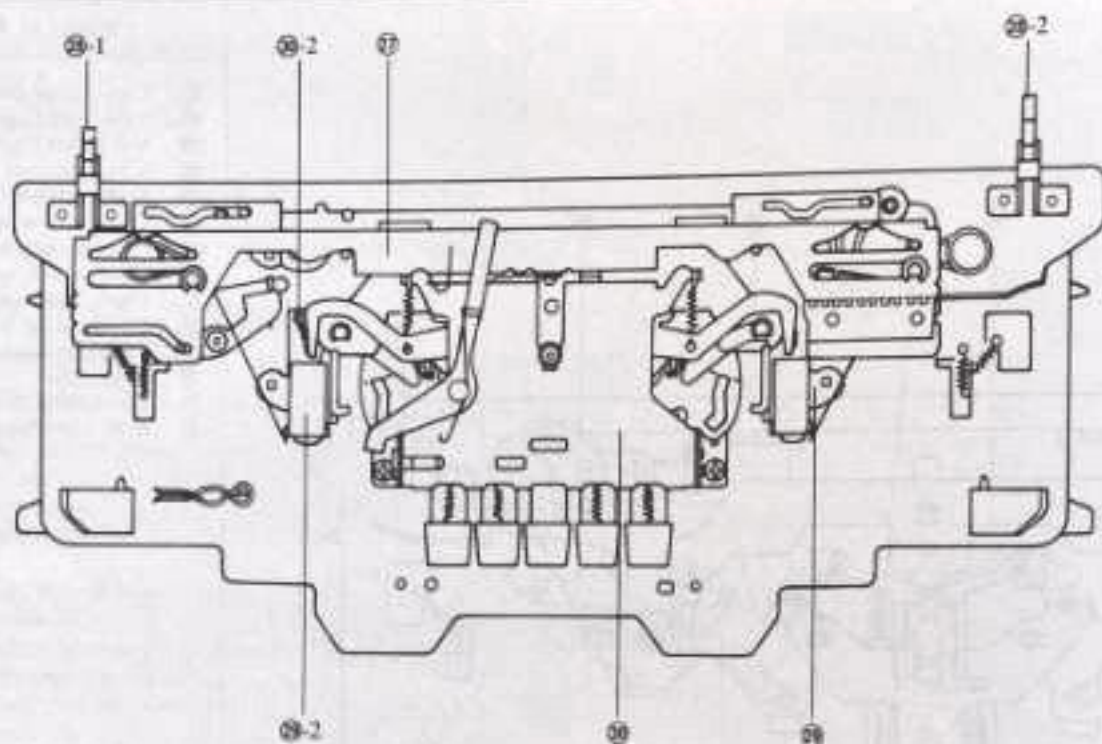

Names of Parts

- 27 Upper slide plate
- 28-1 Knit-leader tripper
- 28-2 Row counter tripper
- 29 Handle setting base
- 29-2 Handle lock spring
- 30 Cam button unit
- 30-2 Raising cam change spring

(Fig. 7)

27. Mounting the upper slide plate

- 27.1 Mount the upper slide plate so that the calking pins of the carriage plate, the connecting plate pins, the cam change plate pins, and the pins of S. M. cam change crank, on both right and left sides, come into eight slots of the upper slide plate. (Be sure to check the pins of needle selection lever are located before the upper slide plate.)
- 27.2 Fix the upper slide plate with snap rings on both right and left carriage calking pins.

28. Mounting the knit-leader tripper and the row counter tripper

- 28.1 Put the knit-leader tripper on the left side and fix it with two screws from the carriage bottom.
- 28.2 Put the row counter tripper on the right side and fix it in the same way.

29. Mounting the handle setting base

- 29.1 Fix the handle setting bases with screws.
- 29.2 Fix the handle lock springs with screws.

30. Mounting the cam button unit

- 30.1 Fit the cam button unit to the shaft of stitch dial and fix it with screws on both sides.
- 30.2 Pull up the right and left raising cam change springs and hook them over the cam calking pins while pushing "Part" buttons right and left. (Be sure to check the cams surely change when the buttons TUCK (R/L), MC, L, PART (R/L), are pushed.)

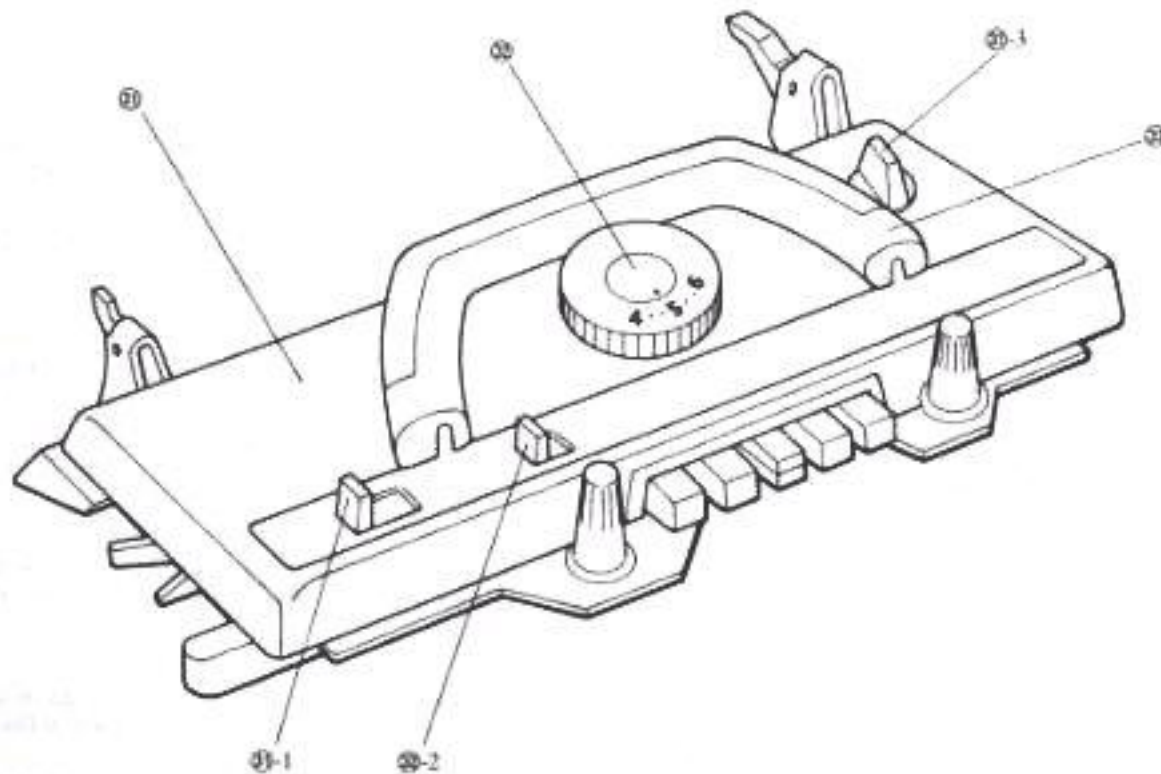

Names of Parts

- ① Carriage cover
- ①-1 H.C.L. knob
- ② Plain lever knob
- ③ Change knob
- ④ Stitch dial cap
- ⑤ Carriage handle

(Fig. 8)

31. Mounting the carriage cover

- 31.1 Put the H.C.L. spring to the shaft of H.C.L. knob and mount the H.C.L. knob over them.
- 31.2 Fit the plain lever knob to the cam button unit.
- 31.3 Mount the change knob onto the knob shaft.
Note: The mark should come right above the number on the stitch dial.
- 31.4 Mount the carriage cover and fix it with screws on the bottom.

32. Mounting the stitch dial

- 32.1 Mount the stitch dial onto the shaft. Fix it with the screw while keeping the cut of stitch dial presser just forward.
- 32.2 Then mount the stitch dial cap onto them while aligning its pointer mark to the cut of stitch dial presser.
* Be sure to check the pointer mark comes right in front of any figure on the stitch dial.

33. Mounting the carriage handle

- 33.1 Fix the handle with pin screws while keeping it down.

CHECKING THE CARRIAGE FUNCTIONS - 1 -

1. Change knob function	1.1 When the change knob is switched to each position, it should move smoothly; the right or left part of the connecting plate and the needle selection switching cam should work without fail.
2. MC cam operating	2.1 When the end of the right or left part of the MC cam is pressed fully down and then quietly lifted with your finger while keeping the MC button depressed all the time, the right and left parts of the MC cam should return to their original position under spring pressure.
3. MC knitting change cam operation	3.1 The right and left parts of the MC cam should shift without fail while the MC button is kept depressed.
4. Raising cam operation	4.1 When the end of the right or left part of the raising cam is lifted fully with the stitch dial at the 0.5 or 0 position and quietly lowered with your finger, the right or left part of the raising cam should return to its original position without fail under spring pressure.
5. Needle selection cam operation	5.1 When the needle selection cam is set at "KC" and when the end of the right or left part of the needle selection cam is fully lifted and then quietly lowered with your finger, the cam should return to its original position without fail under spring pressure.
6. Tuck cam operation	<p>6.1 When the right or left part of the cam button is depressed, and when the end of the right or left part of the cam is fully lifted and then quietly lowered with your finger, the right or left part of the tuck cam should return to its original position without fail under spring pressure.</p> <p>6.2 When the cam button is set at plain, and when the end of the right or left part of the tuck cam should return to its original position without fail under spring pressure.</p>
7. Cam button unit function	7.1 When the cam button is shifted to "TUCK right and left," "MC", "L" or "PART right and left," the button should move smoothly and the tuck cam, the MC cam, the raising cam, push-up cam, thread-face change plate and MC guide cams should shift their places without fail.
8. Holding cam lever function	8.1 When the holding cam lever is shifted to "H" or "N", it should move smoothly and the holding cam should make accurate operation without fail.
9. Plain knitting lever function	9.1 When the plain knitting lever is thrown rightward while pressing "TUCK right and left," "MC", "L" or "PART right and left" buttons, the lever should move smoothly and the cam button should return to its original position without fail.

CHECKING THE CARRIAGE FUNCTIONS - 2 -

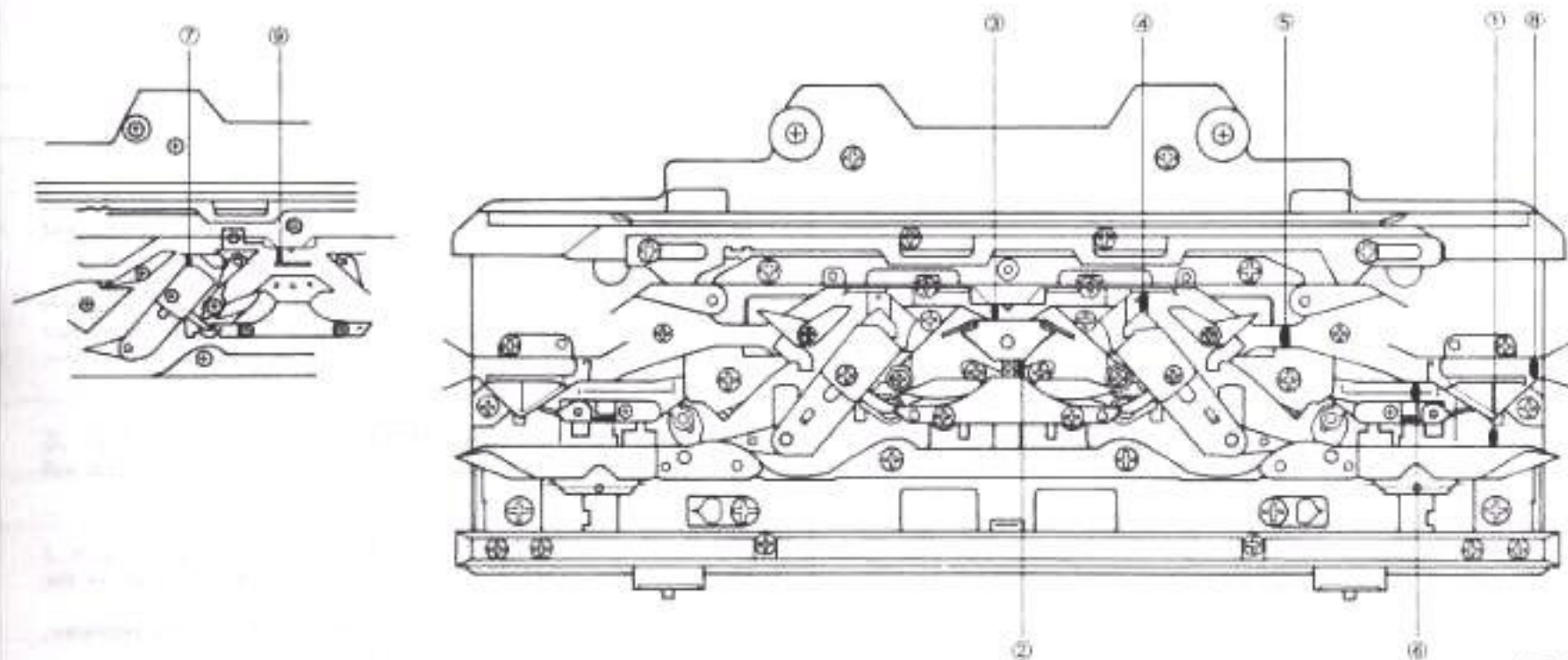

(Fig. 9)

< Check to be sure needle butts smoothly pass the following >

- ① Between the rear foot and the separation cam
- ② Between the tuck cam plate and the thread-lace change plate
- ③ Between the slide guide cam and the slide cam
- ④ Between the push-up cams
- ⑤ Between the needle selection cam and the guide cam A
- ⑥ Between the needle selection cam and the guide cam G
- ⑦ Between the push-up cam and the guide cam A
(when the "L" button is pushed)

- ⑧ Between the guide cam F and the separation cam
- ⑨ Between the slide guide cam and the thread-lace change plate
(when the "L" button is pushed)

HOW TO ADJUST THE CARRIAGE

1. The carriage does not move smoothly. The fabric floats (stitch float)

Cause

1. The sinker plates are in contact with the gate pegs.
There is too much gap between the sinker plates and the gate pegs.

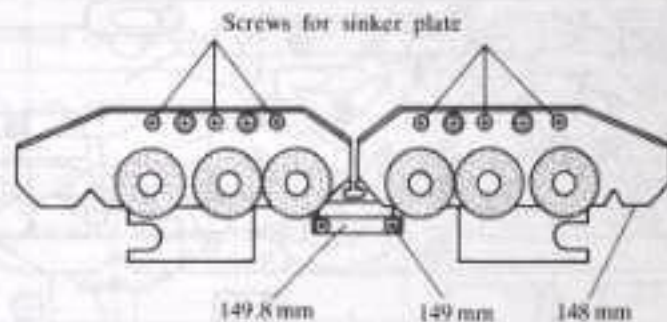

(Fig. 10)

2. The sinker plates keep up the plain needles.
There is too much gap between the sinker plates and the plain needles.

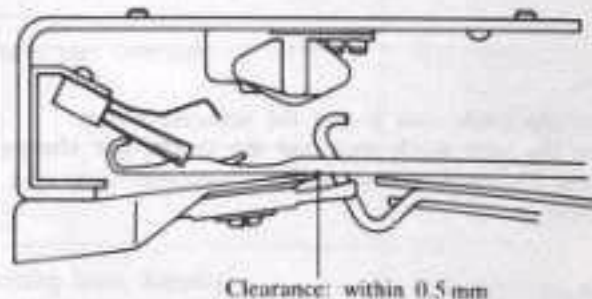

(Fig. 11)

Adjustment

(Longitudinal adjustment of sinker plate)

1. The carriage plate and the sinker plates of this model KH-290 are processed already properly; therefore there is no need to readjust them.
2. Mounting dimension of sinker plate
The standard dimensions between the carriage rear rail and the sinker plate are 149 mm on the inside and 148 mm on the outside. When necessary, loosen six screws of sinker plates on both sides for proper adjustment. (See Fig. 10.)

(Mounting dimension of yarn feeder)

1. Mount the yarn feeder so that the dimension to the carriage rear rail may be 149.8 mm.

(Vertical adjustment of sinker plate)

1. Fit the carriage to the needle bed and set the H.C.L. knob to the position H.
2. Put some five plain needles forward to the point E on three positions: right, middle and left of the needle bed.
3. Bend and adjust the sinker plates so that the clearance between the stems of plain needle and the sinker plates may not exceed 0.5 mm.

2. The carriage stops midway. The latches of plain needle become bent.

Cause

1. The guide cam A is installed wrongly.

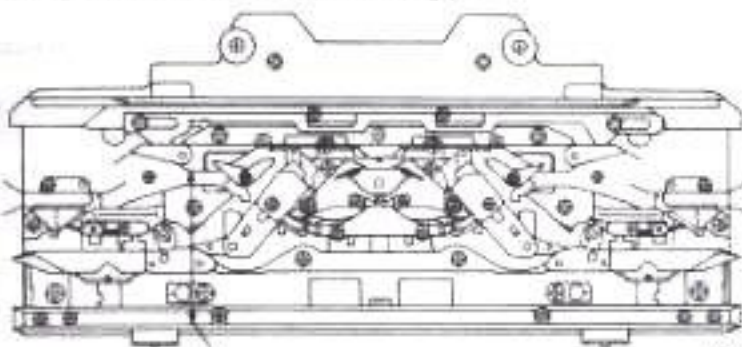

71 mm (±0.3 mm)

(Fig. 12)

Adjustment

(Mounting dimension of guide cam A)

1. Loosen the right and left screws of guide cam A and the nut of change plate. Then clamp again after adjusting the distance from the rear foot may become 71 mm.
* 1. If the mounting dimension between the guide cam A and the rear foot should not reach 71 mm, the plain needles cannot pass there, narrow clearance between the guide cam A and the needle selection cam.

3. Single motif pattern cannot be knitted: the butts get contact with the needle selection change cams.

Cause

1. Fault of needle selection change cam

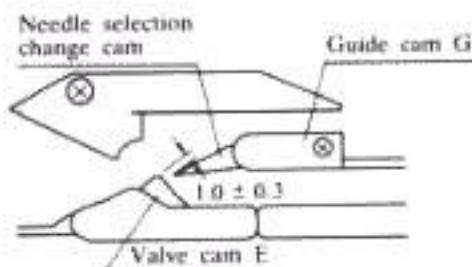

2. Wear of motif knitting cam and rear foot

(Fig. 13)

Adjustment

1. Replace the needle selection change cams.
① Set the change knob to the position "NL".
② Remove the guide cam G.
③ Remove the needle selection change cam.
2. Replace the motif knitting cam or the carriage rear foot.
(NOTE)
With regard to each of the above items 1 and 2, both top ends of needle selection change cams should be located inward from the valve cam E as shown in Fig. 13; 1.0 mm ± 0.3.

4. The end needle selection cannot be performed.

Cause

1. Fault of selection cam for end needle
Heavy operation
Wear

Adjustment

1. Replace the selection cam for end needle

- ① Remove the carriage cover.
- ② Remove the springs of valve cam F and the end needle selection springs.
- ③ Set the change knob to the "NL" position and push the button "PART right and left". Then remove the guide cam Gs, the needle selection change cams, the needle selection change spacers (collars), and the valve cam Fs.
- ④ Remove the needle selection cams, the separation cams, and the guide cam Fs.
- ⑤ Loosen and remove six screws to detach the rear foot from the carriage plate.
- ⑥ Then the selection guides for end needle and the selection cams for end needle come off.

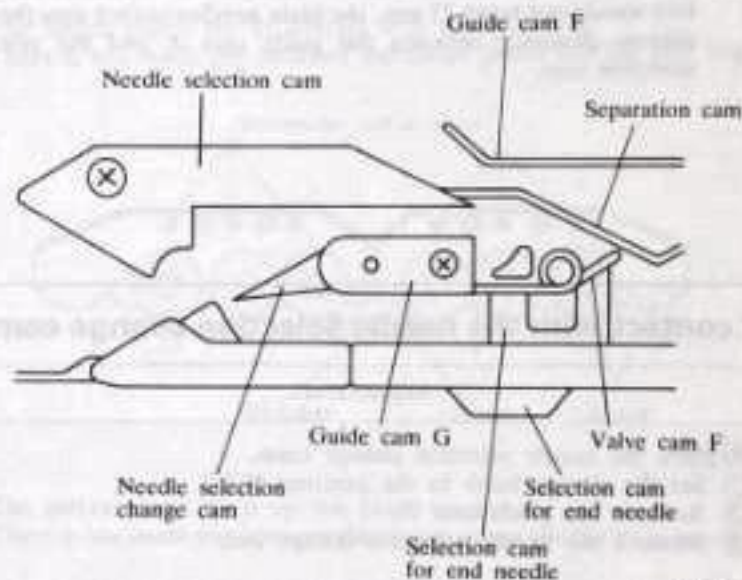

(Fig. 14)

MOUNTING DIMENSIONS OF EACH CARRIAGE CAM

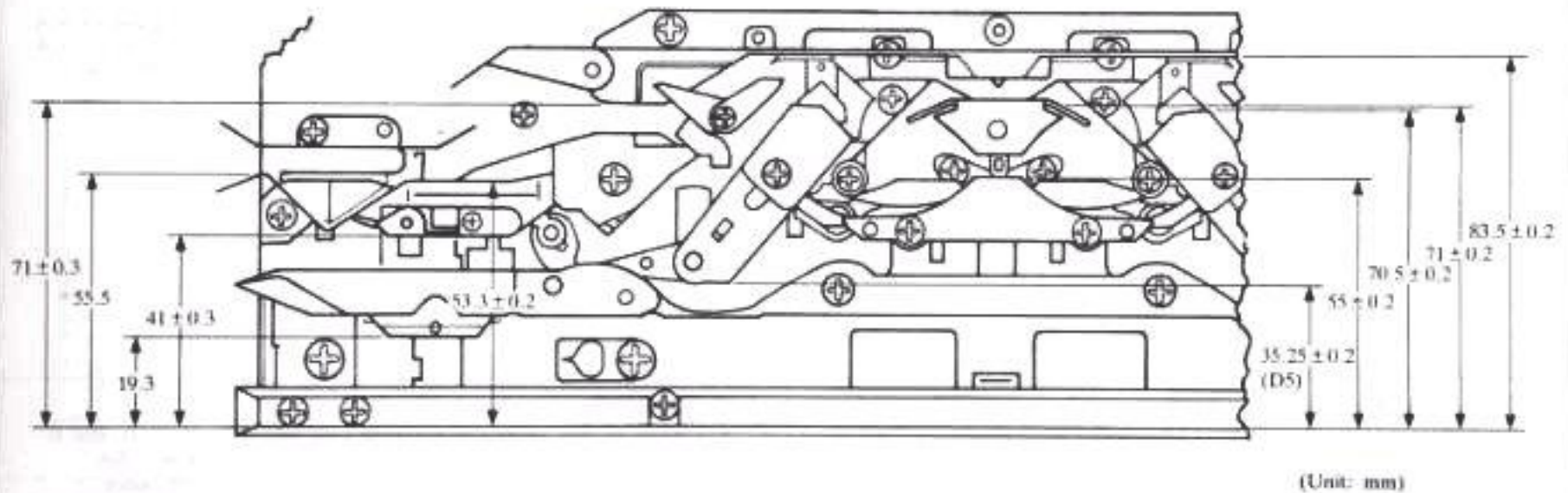

(Fig. 15)

DISASSEMBLING THE MACHINE BODY

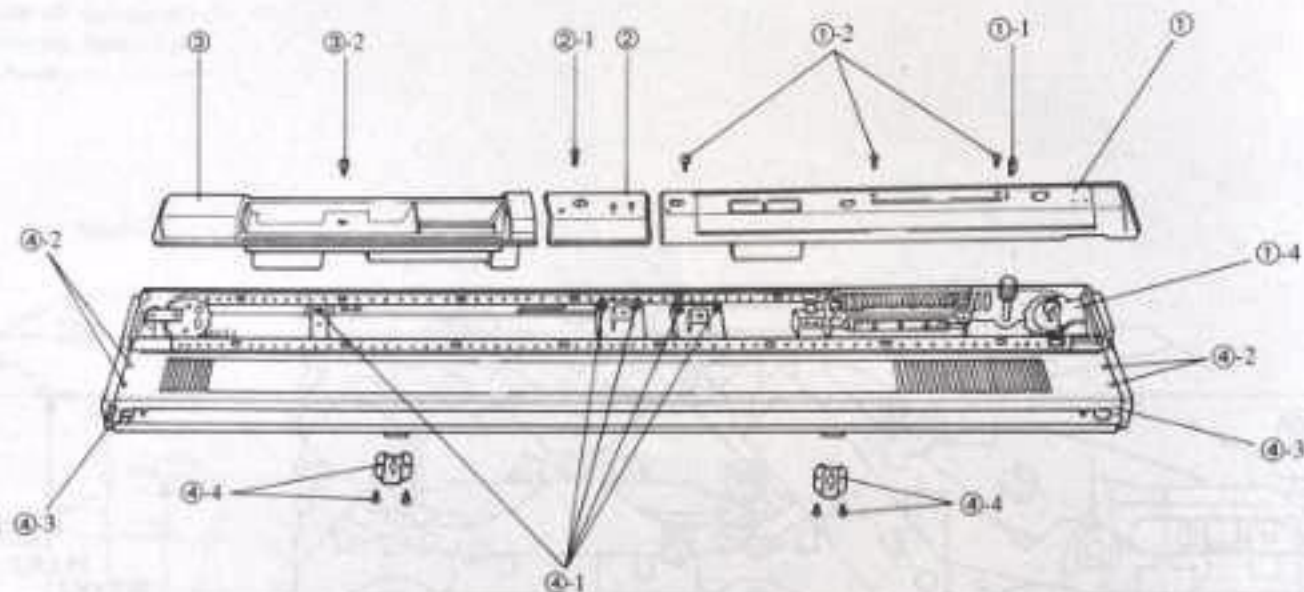

Names of Parts

- ① Panel assembly
- ①-1 Card lock lever knob
- ①-2 Screw for panel
- ①-3 Push button
- ①-4 Direction indicator plate
- ② Row counter panel
- ②-1 Screw for row counter panel
- ③ Accessories box
- ③-2 Screw for accessories box
- ④-2 Needle bed clamp screw A
- ④-3 Needle bed clamp screw B
- ④-4 Screw for table clamp setting plate

(Fig. 16)

1. Removing the panel

- 1.1 Remove the card stop lever knob with a small slotted screwdriver.
- 1.2 Remove three screws for the panel.
- 1.3 Lift up and remove the panel while sliding it to the left.
- 1.4 Remove the push button and the direction indicator plate.

2. Removing the row counter panel

- 2.1 Remove a screw to lift up and detach the row counter panel.

3. Removing the accessories box

- 3.1 Take off the accessories box cover and remove the screw.
- 3.2 Lift up and remove the box while sliding is to the right.

4. Removing the machine body

- 4.1 Remove five screws of carrying case reinforce plate A and B
- 4.2 Remove four needle bed clamp screw As on both sides.
- 4.3 Remove two needle bed clamp screw Bs on both sides
- 4.4 Remove four screws of right and left table clamp setting plates on the bottom.
- 4.5 Detach the machine body from the case.

1.1 Insert the card guide between the card roller and rotary cam from the left side, and insert the card roller shaft and rotary cam into two holes in the card feed base. Then lock the card feed bases, right and left, with card guide mounting screws.

* Clearance between the card roller and card guide should equal the total thickness 0.6 mm of three punch cards.

1.2 Insert the card roller unit into the needle selector unit. It is necessary to hook the ratchet onto the card feed stopper plate on the card feed base (right). Next, lock the card feed bases, right and left, to the rear of the needle selector unit by means of spring plate and clamp screws temporarily.

1.3 Insert the card feed knob stopper cam into the needle selector unit from underside, then fix the intermittent feeding lever, change lever and spring. Insert the card feeding knob shaft into the card feed knob stopper cam, intermittent feeding lever and change lever from top of the needle selector unit.

1.4 Insert the card feed adjusting plate into the needle selector unit, and secure the card feed lever with step screws.
Make sure that the intermittent feeding lever should go between the card feeding lever and round plate.
(Please refer to Fig. 42 on page 40.)

1.5 Insert the card feed cam and bevel gear stopper plate into the needle selector unit from the right side, and insert the clutch wheel and clutch cam A into the needle selector unit from its top. (Align the cut portion of the clutch wheel with top of the needle selector plate cam, and position the needle selector cam so that the cam lobes are on the other side and the flat portion is in a horizontal position. Then mesh the bevel gears. Refer to the figure on the right on page 27.) Next, pass the clutch cam A between the card feed cam lobes, and place the card reader return cam from the bottom side of the needle selector unit, and lock with washer and E-shaped stopper ring 2.5.

1.6 Install the clutch spring.

1.7 Insert the belt guide plate (right) into the needle selector unit from the right side, and lock with screws (with washers).

1.8 Install the card reader release spring.

1.9 Install the center stay and right stay in the positions (marked on the needle selector unit with a slotted-head screw driver when disassembled), and secure with screws (with washers).

Card feed lever adjustment

Turn clutch cam A in either direction so that the card feed cam pushes the card feed lever upward. Then push down the right side of the card feed lever until the ratchet begins to move, and lock with step screw.

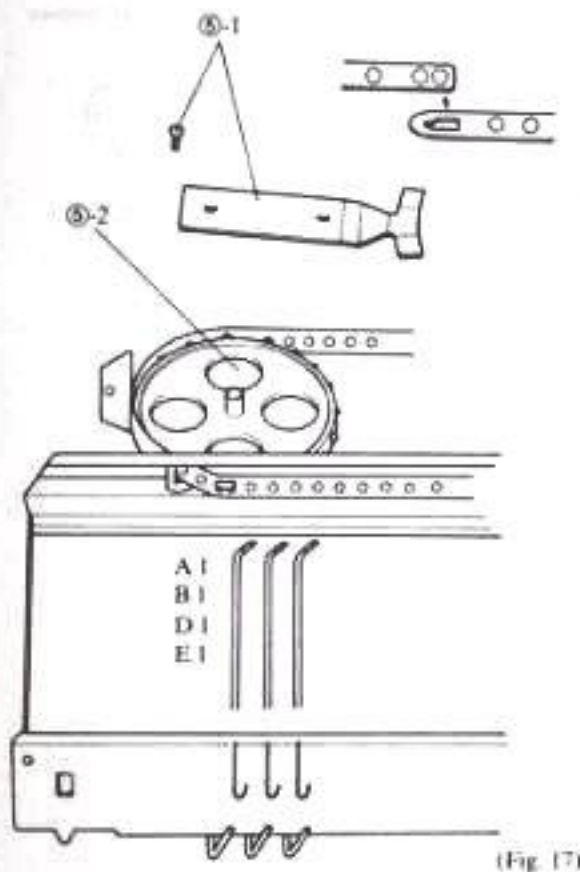

(Fig. 17)

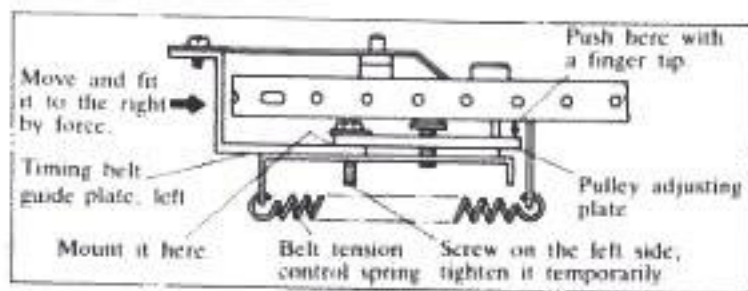

(Fig. 17-1)

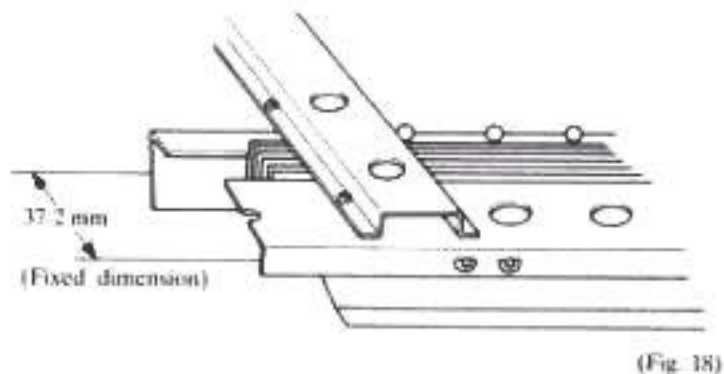

(Fig. 18)

Names of Parts

- ⑤-1 Brake spring and screw
- ⑤-2 Screw with washer for pulley adjusting plate

5. Removing the timing belt

- 5.1 Remove the screw to pull up and detach the brake spring
- 5.2 Loosen both two screws of pulley adjusting plate first. Then move and fit the timing belt guide plate, left to the right and tighten one screw of pulley adjusting plate on the left side temporarily while pushing the right end of the pulley adjusting plate with a finger tip. (Fig. 17-1)
- 5.3 Remove the timing belt by taking off its connecting pin.

(Be sure to check the dimension between the needle selector plate holder and the needle bed.)
Measure and note down the distance shown in the above figure with slide calipers. Mount them to this fixed distance in reassembling.

ASSEMBLING THE NEEDLE SELECTOR PLATE HOLDER

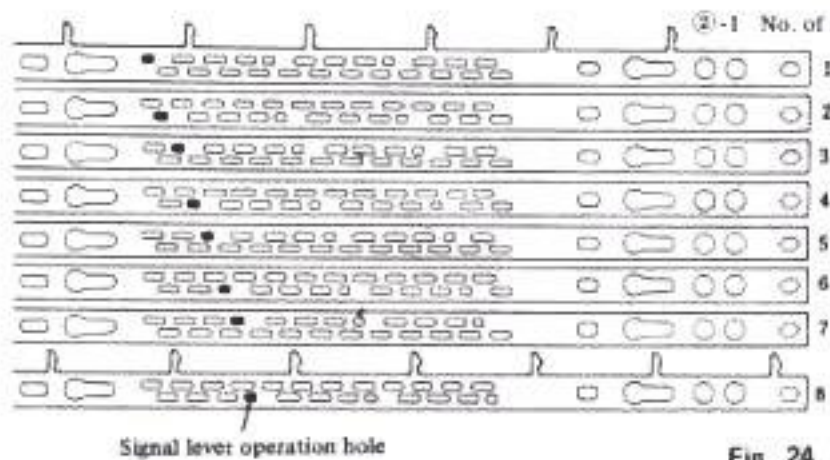

Fig. 24

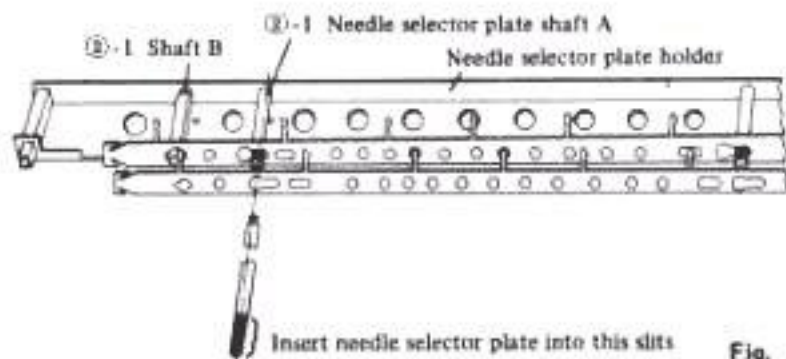
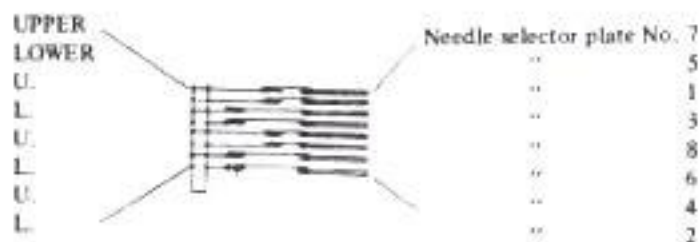

Fig. 25

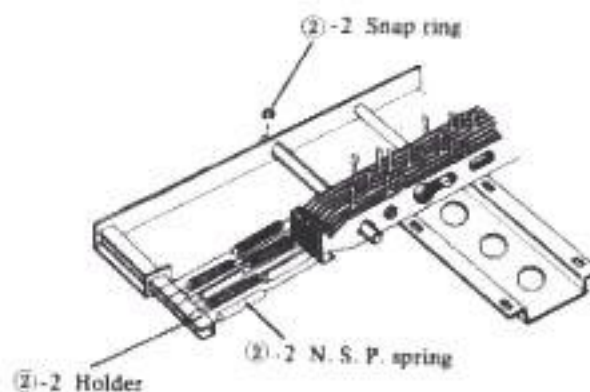
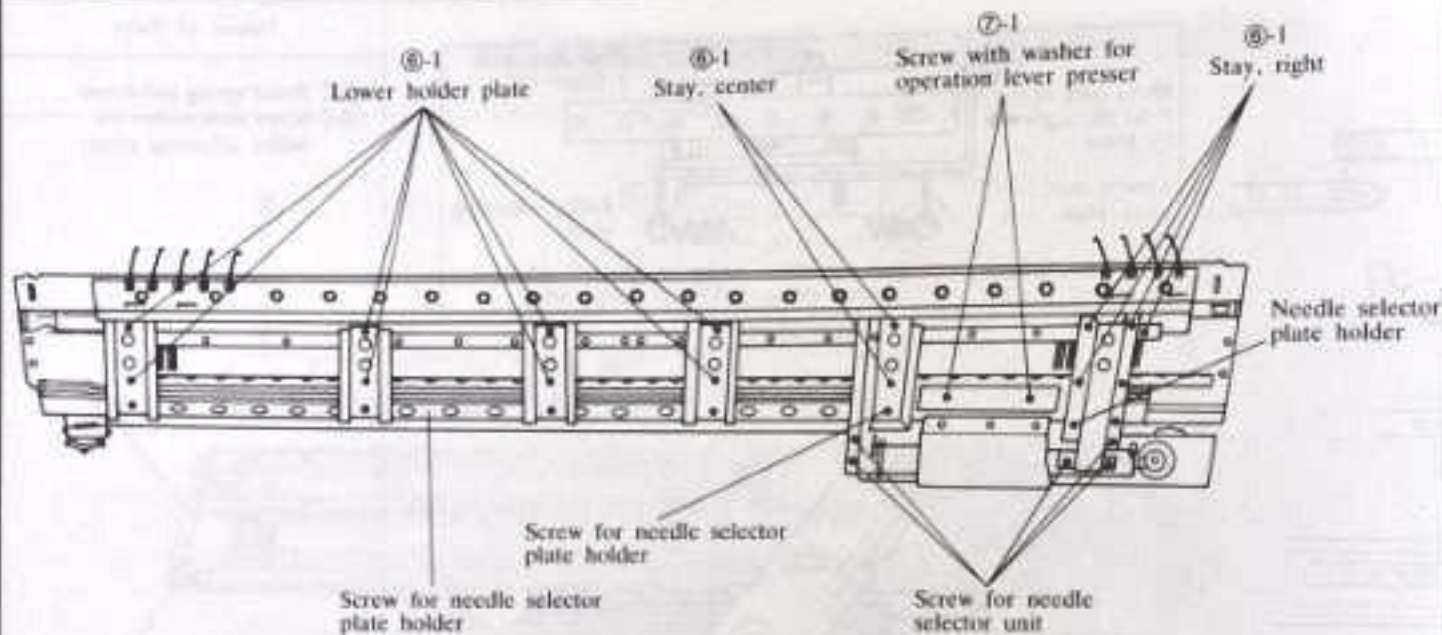

Fig. 26

2.1 Install the needle selector plates on the needle selector plate holder in the order of 7, 5, 1, 3, 8, 6, 4 and 2. Align the needle selector plates with the slits of needle selector plate shafts A (6 pieces), then insert the needle selector plate shafts B and secure with E-shaped snap ring.

2.3 Hook eight needle selector plate springs on spring hooks as illustrated above Fig. 26. Springs should be hooked on to the lower part of needle selector plates, 5, 3, 6 and 2 and on to the upper of needle selector plates, 7, 1, 8 and 4. In other words, springs are positioned up and down alternately.



(Fig. 19)

Names of Parts

①-1 Screw with washer for operation lever presser

NOTE

1. Never remove seven screws of the needle selector plate holder and five screws of the needle selector unit, shown in the above figure, except when the needle selector unit is disassembled.
2. The mounting dimension of gate pegs can be adjusted even if the stays are not removed. (See How to Adjust the Machine Body on page 42.)
3. In repairing the card readers and the operation lever, symptoms and causes can be detected easily if the card reader holder and the card reader spring presser plate are removed.

6. Removing the needle selector unit (with the needle selector plate holder)

- 6.1 Remove fourteen screws with washers provided for the stays and the lower holder plates on their gate peg side. Then the needle selector unit comes off as combined with the needle selector plate holder.

7. Removing the needle selector unit from the needle selector plate holder

- 7.1 Remove two screws to detach the operation lever presser and pull out twenty-four N.S.P. operation levers.
- 7.2 Remove one screw for the needle selector plate holder at the center stay and the two screws at the right stay, then needle selector unit comes off.

ASSEMBLING THE NEEDLE SELECTOR PLATE HOLDER IN THE BODY

Take measure of a distance between the needle bed lower plate and needle selector plate holder at three places – both ends and the central part of the holder – by use of a sliding calipers.

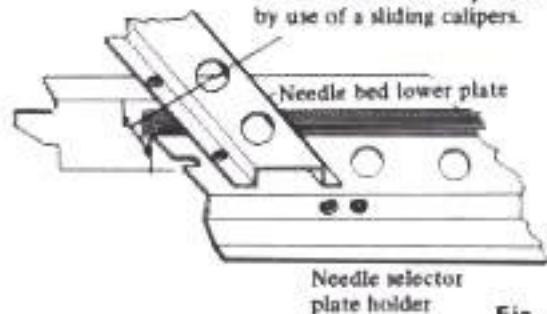

Fig. 29

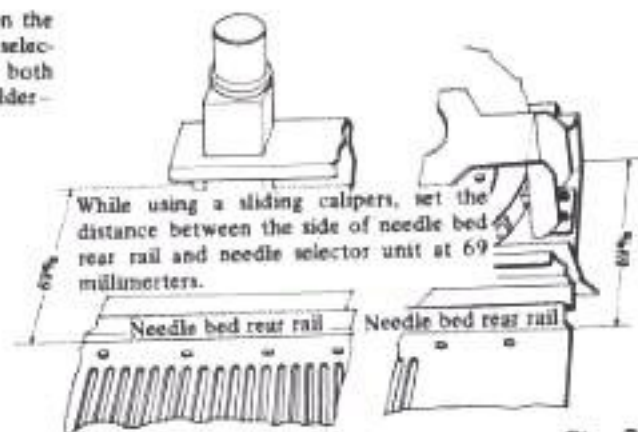
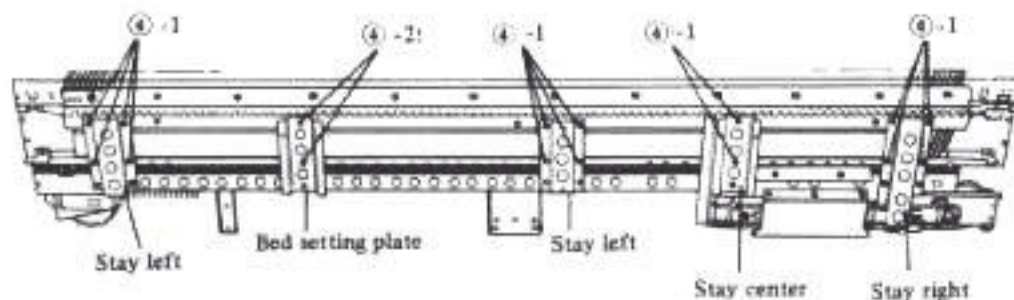

Fig. 30



Name of parts

- ④-1 Stay fitting screw
- ④-2 Machine clamp screw

4.1 Set the needle selector unit to the machine body and fasten with four clamp screws for the left, central and right stays each and two clamp screws for bed setting plate temporarily and after making adjustments mentioned below, fasten the needle selector formally.

Fitting of the needle selector plate holder

Fit the needle selector plate holder according to the measurement made with a sliding calipers as described in Figure 29.

Fitting of the needle selector unit

Fit the needle selector unit so that the distance between the unit and the side of needle bed rear rail come to 69 millimeters.

Names of Parts

- (B)-1 Needle selector plate spring
- (B)-2 Snap ring for shaft B

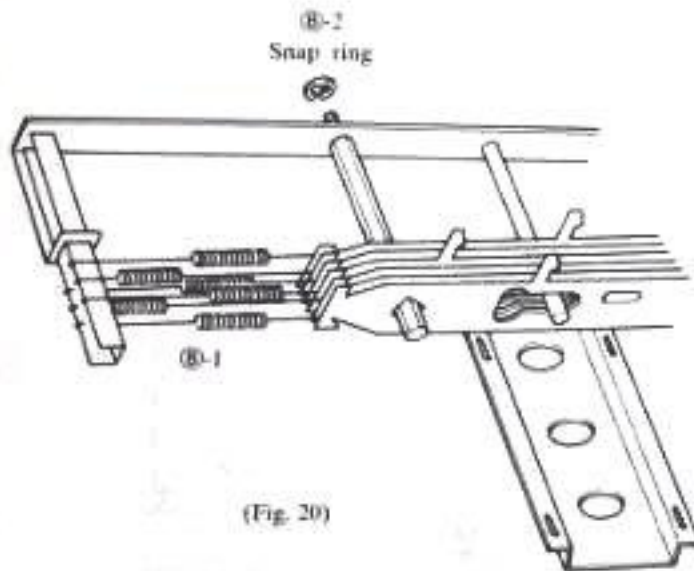

(Fig. 20)

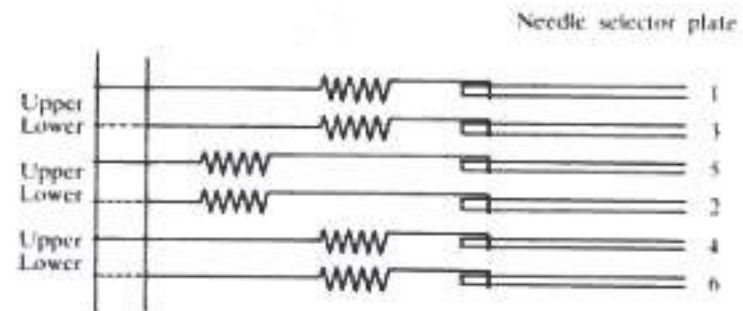

(Fig. 21)

8. Disassembling the needle selector holder

- 8.1 Remove six needle selector plate springs.
(Be sure to check the position and direction of each spring.)
- 8.2 Remove the snap ring from the square shaft B, provided on the rear of the needle selector plate holder. Then pull out the shaft for removal.

- 8.3 Remove six needle selector plates from the shaft A while sliding them one by one to the right.

ASSEMBLING THE NEEDLE SELECTOR PLATE HOLDER IN THE BODY

Take measure of a distance between the needle bed lower plate and needle selector plate holder at three places – both ends and the central part of the holder – by use of a sliding calipers.

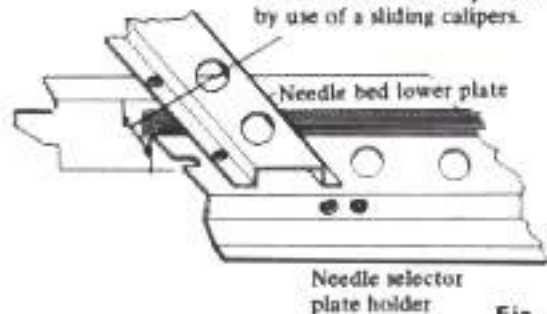

Fig. 29

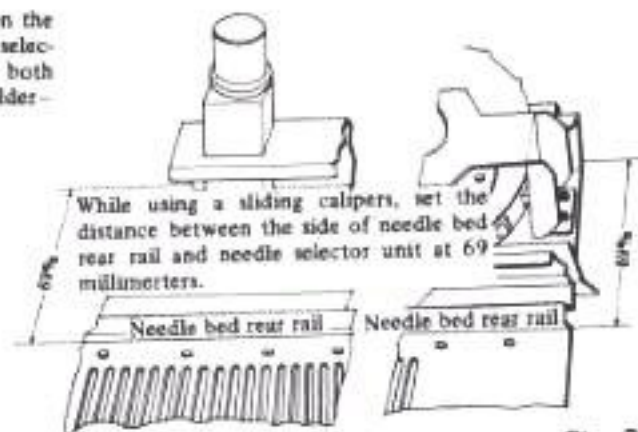
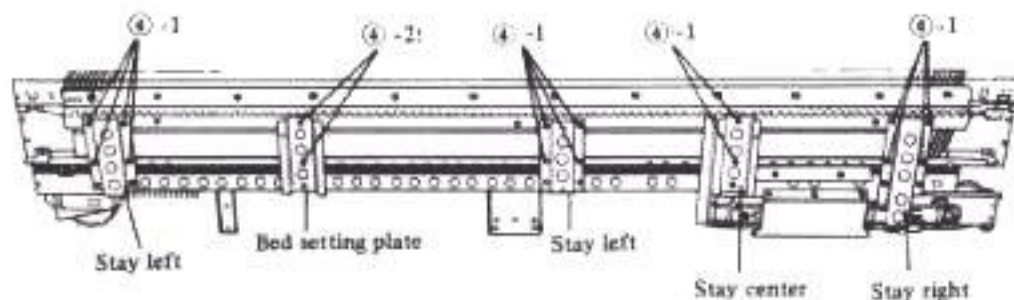

Fig. 30



- 4.1 Set the needle selector unit to the machine body and fasten with four clamp screws for the left, central and right stays each and two clamp screws for bed setting plate temporarily and after making adjustments mentioned below, fasten the needle selector formally.

Fitting of the needle selector plate holder

Fit the needle selector plate holder according to the measurement made with a sliding calipers as described in Figure 29.

Fitting of the needle selector unit

Fit the needle selector unit so that the distance between the unit and the side of needle bed rear rail come to 69 millimeters.

Name of parts	
④-1	Stay fitting screw
④-2	Machine clamp screw

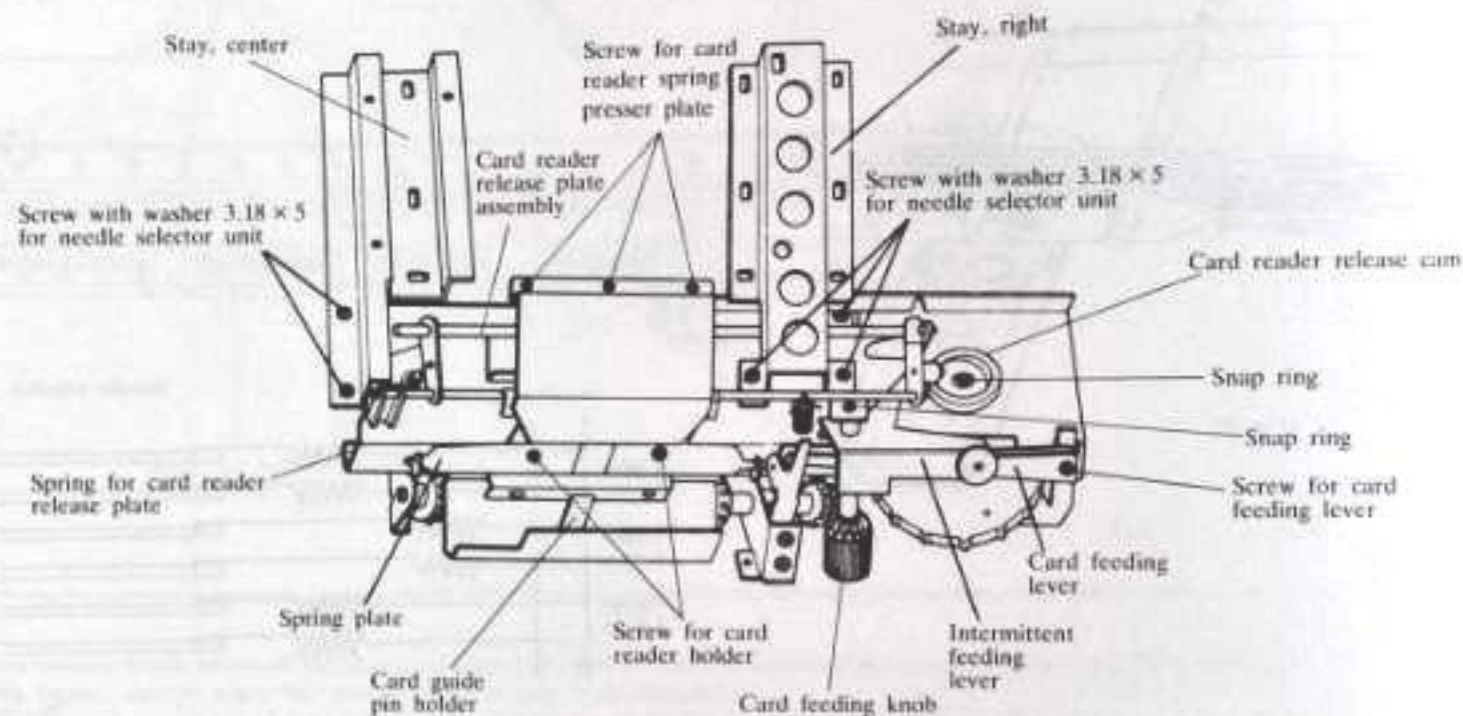

(Fig. 23)

9. Disassembling the needle selector unit

- 9.1 Remove five screws with washers which clamp the needle selector unit onto the stays, center and right to remove these stays.
* Scramble and mark the needle selector unit with a slotted screwdriver having a thin top to indicate the positions of the center and right stays before removing them. They are properly reassembled to these marks of the needle selector unit.
- 9.2 Remove three small screws for card reader spring presser plate, then the card reader spring presser plate and the card reader spring come off.

- 9.3 Remove two screws with washers for card reader holder. Pull out the right and left spring plates and the card reader holder forward to remove twenty-four card readers. Then the card guide pin holder (resin) comes off.
- 9.4 Remove two screws with washers for the right timing belt guide plate. Pull out the right timing belt guide plate in the right direction for removal. (Fig. 23)
- 9.5 Remove the clutch spring. (Fig. 23)

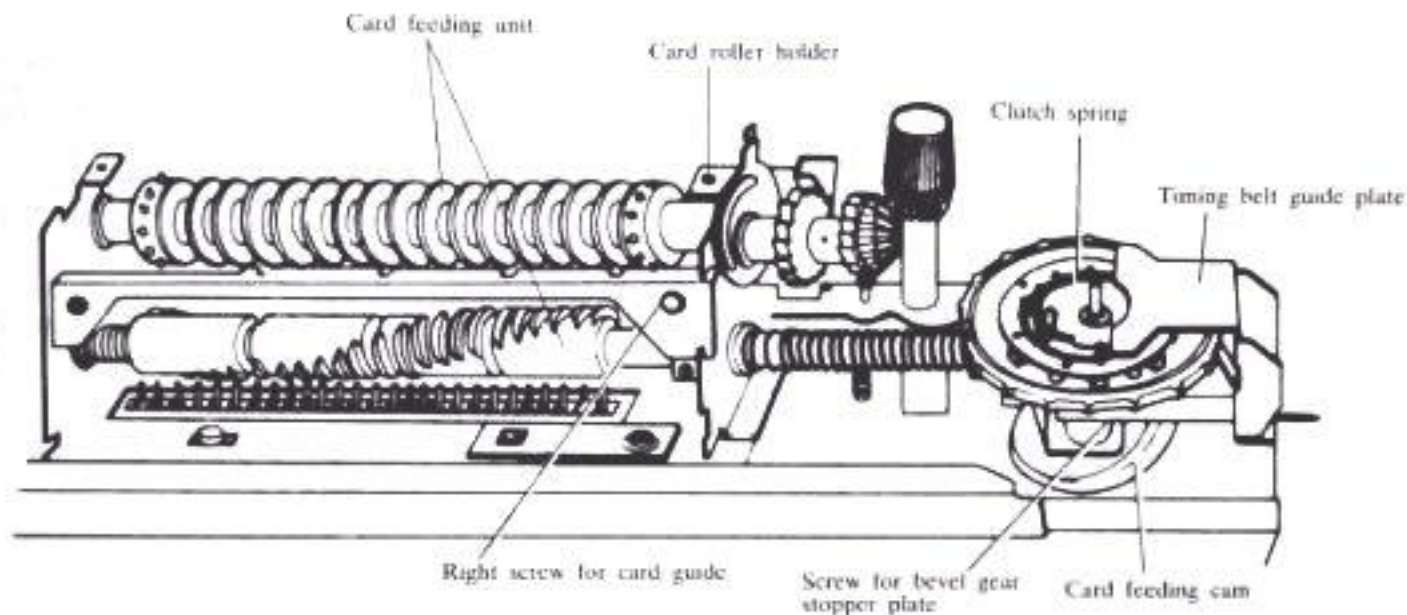

(Fig. 23)

- 9.6 Remove the snap ring attached on the lower side of the clutch shaft. Then the following parts come off; the washer, the card reader release cam, the clutch wheel, the clutch gear, the clutch collar, and the clutch cam A. (Fig. 22)
- 9.7 Remove the screw for bevel gear stopper plate.
- 9.8 Pull out and remove the card feeding unit assembly (card roller unit).
- 9.9 Remove the snap ring attached on the lower side of the card feeding knob. Then the card feeding knob assembly can be removed upward and the intermittent feeding lever, the change

- lever, and the intermittent feeding lever spring come off. Now the card feeding knob stopper cam can be removed upward. (See Fig. 52)
- 9.10 Remove the screw for the card feeding lever, then this lever comes off. And remove the card feeding adjuster plate.
- 9.11 Remove the spring for card reader release plate attached on the card reader release shaft.
- 9.12 Remove both right and left screws for card guide, then the left card roller holder and the card guide come off in the left direction.

ASSEMBLING THE MACHINE BODY

1. Assembling the needle selector unit

- 1.1 Insert the card guide between the card roller and the rotary cam from the left side and put the card roller shaft and the rotary cam shaft into the two holes of the card roller holder, left. Then assemble the card roller holders, right and left with the card guide screws.

* (The clearance between the card roller and the card guide should be 0.6 mm or equivalent to the thickness of three punch cards.)

- 1.2 Fit the card roller unit to the needle selector unit, positioned the card lock lever on ∇ (double length-position) (while hooking the ratchet onto the card feeder stopper plate of the card roller holder, right). Fix the card roller holders, right and left temporarily with the right and left spring plates and screws respectively at two places. Fit the bevel gear stopper plate to the bevel gear side and fix them with screws.
- 1.3 Insert the card feeding knob stopper cam into the needle selector unit from the bottom side and fit the intermittent feeding lever, the change lever, and the intermittent feeding lever spring. Insert the card feeding knob shaft into the card feeding knob stopper cam, the intermittent feeding lever, and the change lever. Then fix the lower side of the knob shaft with the snap ring (Fig. 25) and hook the intermittent feeding lever spring (Fig. 52 on page 47).
- 1.4 Insert the card feeding adjuster plate into the needle selector unit and clamp the card feeding lever with the screw (Fig. 49 on page 46).
(The intermittent feeding lever should be located between the card feeding lever and the round plate: Fig. 51 on page 47.)
* The card lock lever should change to three stages. (Fig. 24)
- 1.5 Insert the card feeding cam into the needle selector unit from the right side and put the clutch collar (concave part, down), the clutch gear, the clutch wheel, and the clutch cam A onto the needle selector unit: **turn the clutch wheel so that its • mark may be aligned to the flat part of the rotary cam.** (Fig. 26 & 27) Mount the card feeding cam, and put the card reader release cam from the bottom side of the needle selector unit. Finally fix them with the washer and the snap ring. (Fig. 25)
- 1.6 Hook the clutch spring

(Adjustment of card feeding lever)

Loosen the stud screw of the card feeding lever and retighten it so that the length of the appearance of the card feeding adjuster plate are equal between upper and lower side of the card feeding lever. (See the page 46.)

- 1.7 Insert the timing belt guide plate, right into the needle selector unit from the right side and fix it with the screw with washer
- 1.8 Hook the spring for card reader release plate over the shaft of the card reader release plate.
- 1.9 Position and fix the center and right stays to the needle selector unit with screws and washers by referring to the marks scratched on the needle selector unit with a slotted screwdriver when disassembling.

(Adjustment of rotary cam and clutch wheel)

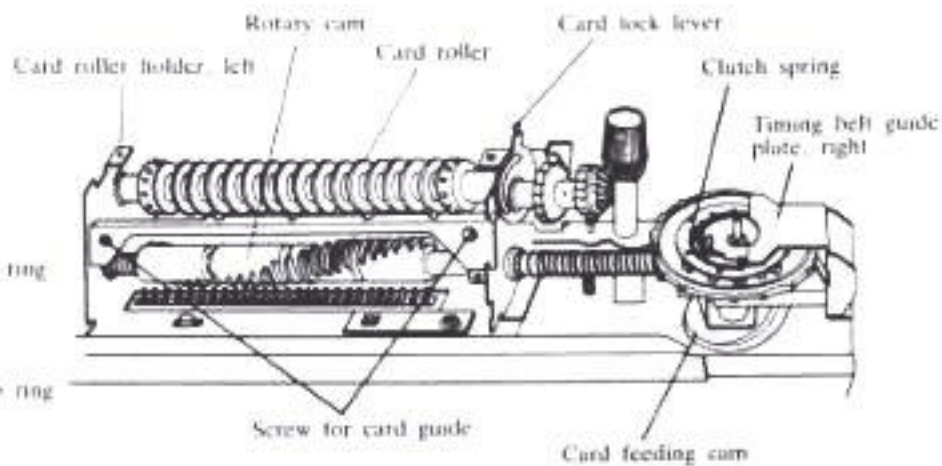
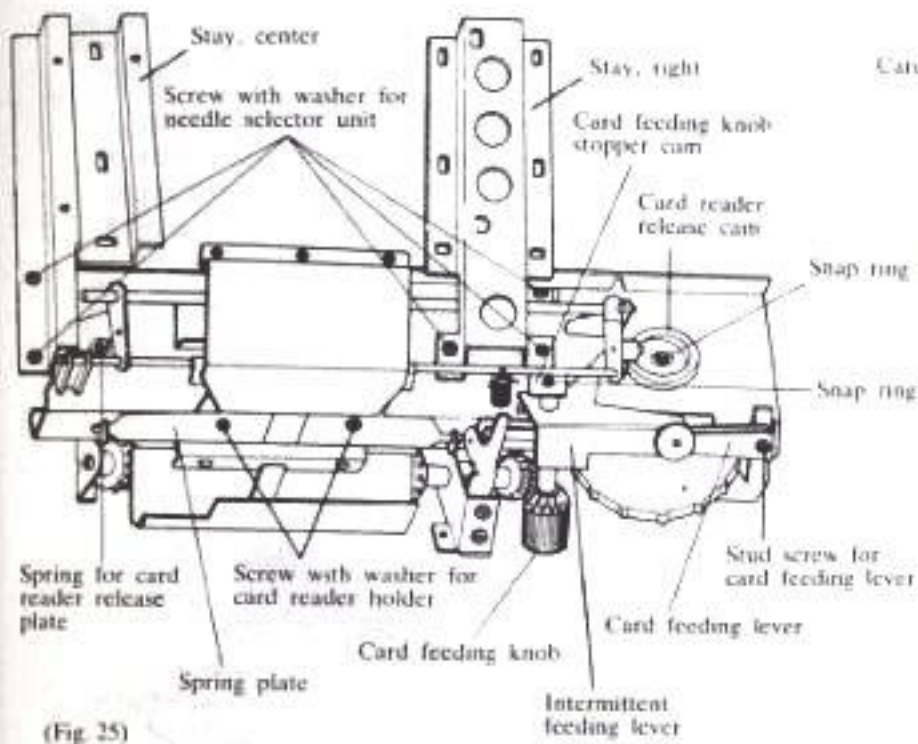

(Fig. 24)

How to adjust the Rotary cam and Clutch wheel

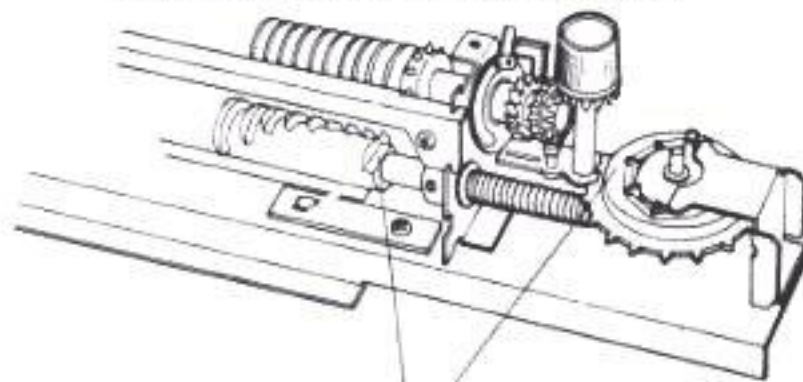

- ① Make these flat parts horizontal to each other.
- ② Turn the clutch wheel to the right and align the ● mark to the flat part of the rotary cam for assembly while keeping the clutch gear on the bottom side closely in contact with the E part.

(Fig. 26)

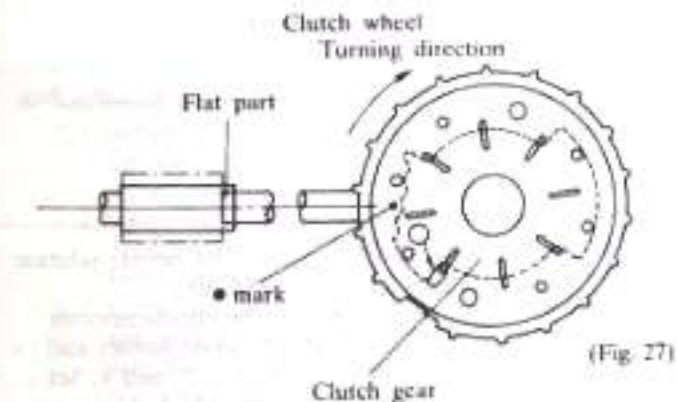

(Fig. 27)

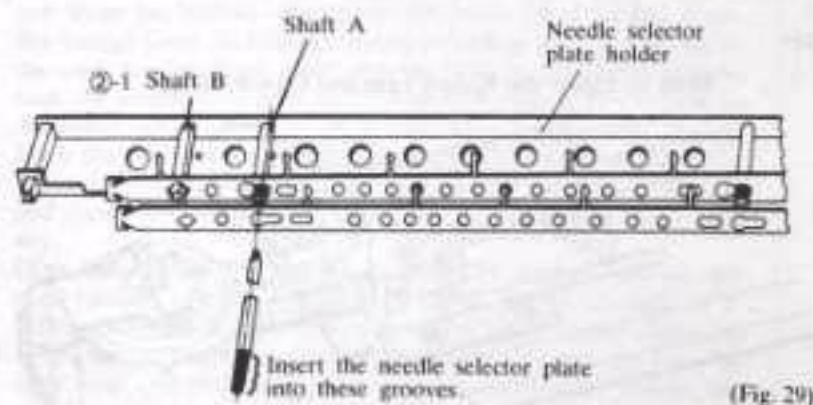
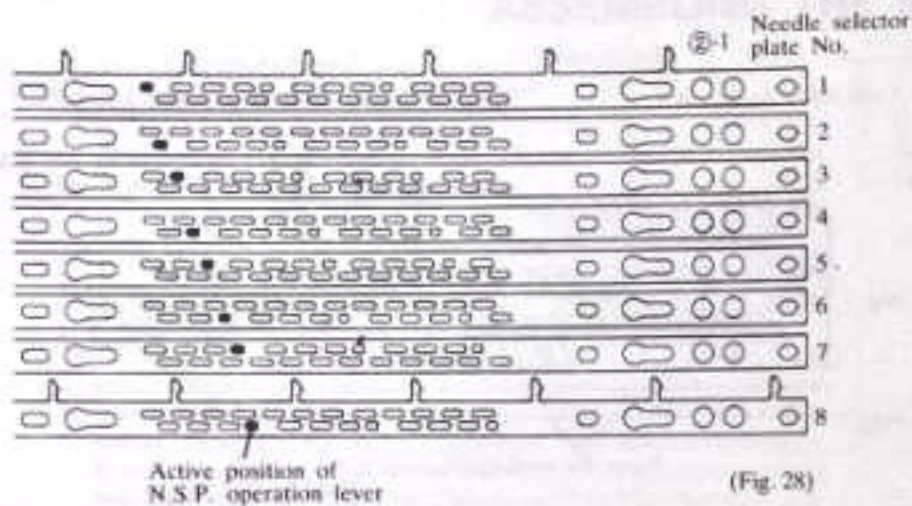

2. Assembling the needle selector plate holder

2.1 Put the needle selector plates 1, 3, 5, 2, 4, and 6 to the needle selector plate holder in this order. Fit these needle selector plates to the shaft A while setting each plate to the seven grooves of the shaft A and sliding them to the left respectively. Then insert the square shaft B and fix them with the snap ring.

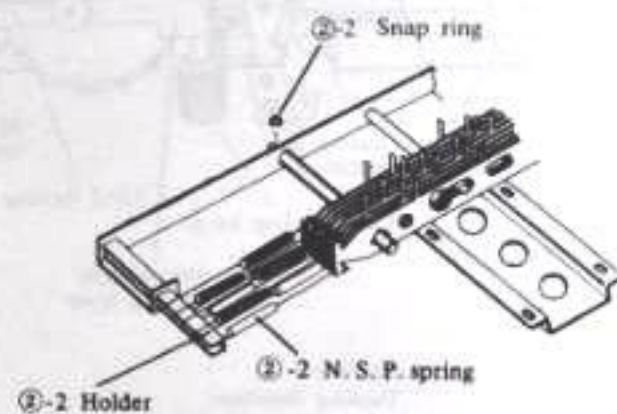
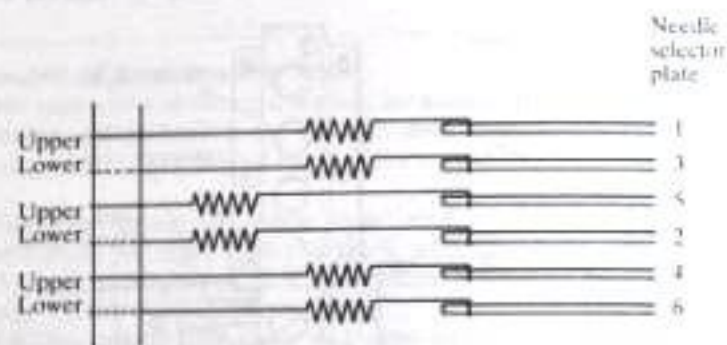

(Fig. 30)

2.2 Hook the six needle selector plate springs on the needle selector plates and the spring hook as shown in Fig. 30.
(Be sure to set the three springs lower to the needle selector plates 3, 2, and 6 from the needle selector plate holder and the other three springs upper to the plates 1, 5, and 4. Set these springs, upper and lower, alternately.)

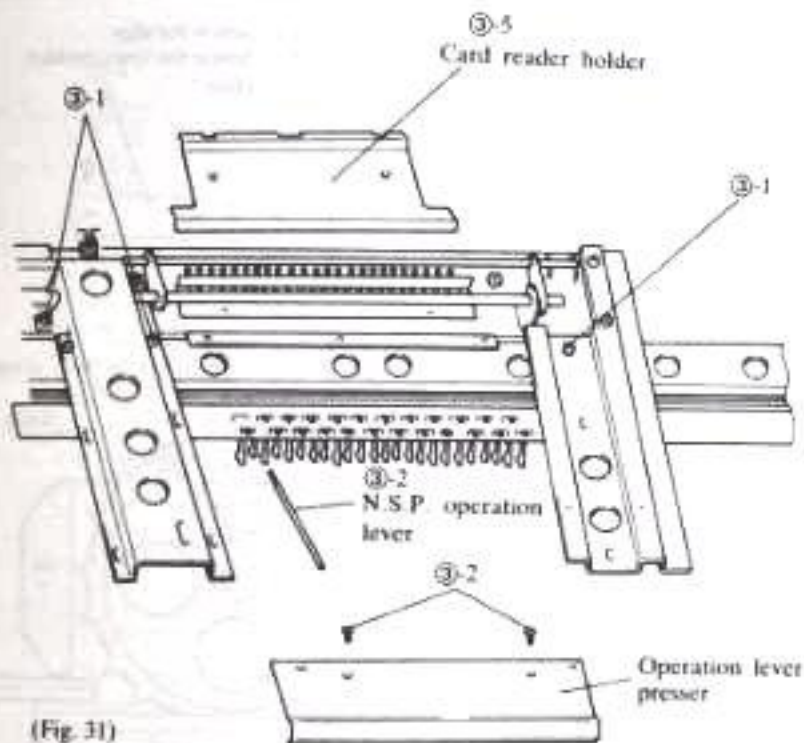

(Fig. 31)

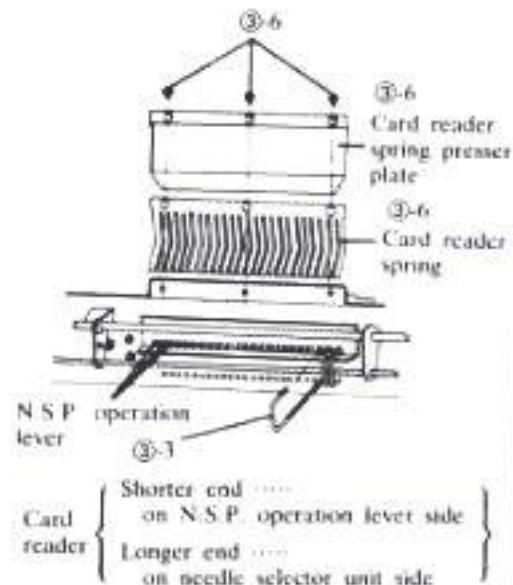

(Fig. 32)

Names of Parts

- ③-1 Screw with washer for needle selector plate holder
- ③-2 Screw for operation level presser
- ③-3 Card reader
- ③-5 Card reader holder
- ③-6 Card reader spring
- Card reader spring presser plate

3. Assembling the needle selector unit in the needle plate holder

- 3.1 Install the needle selector unit in the needle selector plate holder. Tighten the three screws for needle selector plate holder on the center and right stays.
- 3.2 Insert the twenty-four N.S.P. operation levers (thin tips) from the needle selector plate side and attach the operation level presser. Then fix them with two screws.
- 3.3 Turn the needle selector unit upside down and insert the twenty-four card readers into the needle selector unit. Check to be sure these card readers are located on the push button side of the operation levers.

- 3.4 Remove the screws which clamp the right and left spring plates temporarily to detach both spring plates.
- 3.5 Put the card guide pin holder (plastic) to the card reader holder and the spring plates to the card roller holders on both sides. And fix them with screws and washers.
- 3.6 Place the card reader spring so that the card reader is positioned under the center of each tooth of the card reader spring and hold down the spring with the card reader spring holder. Then secure with three screws.
Be sure to check the card reader spring is located properly over the twenty-four card readers.

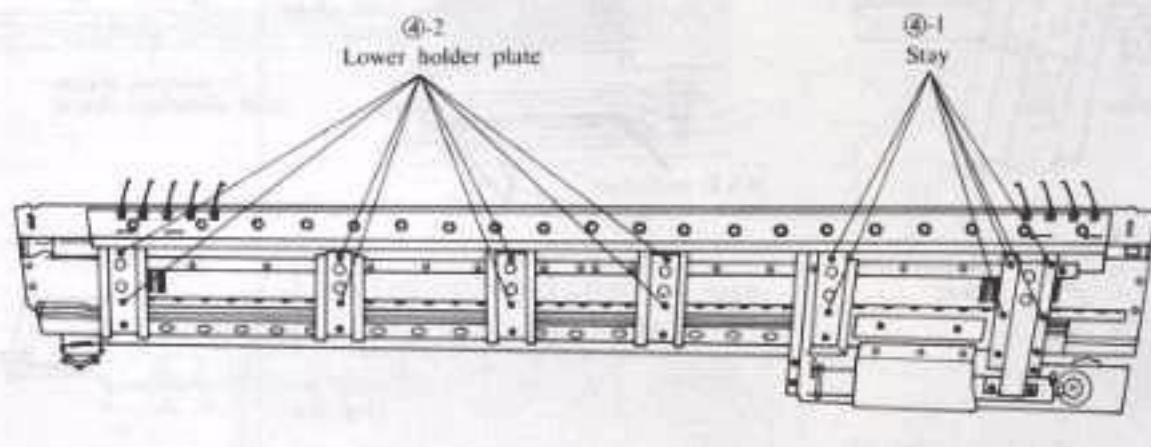
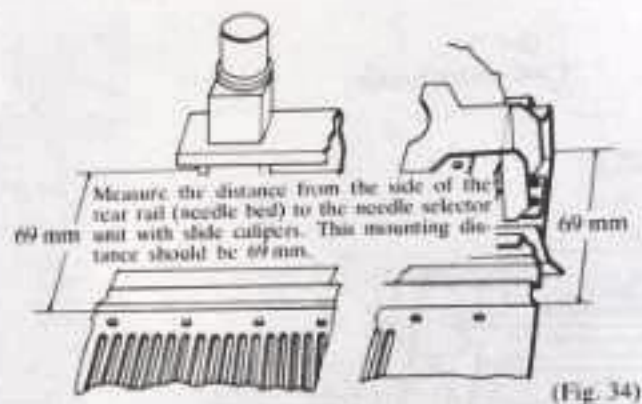
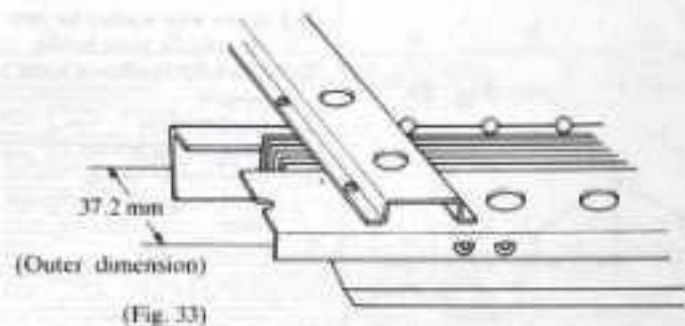

Names of Parts

- ④-1 Screw for stay
- ④-2 Screw for lower holder plate

4. Mounting the needle selector unit (with the needle selector plate holder) onto the machine body

- 4.1 Mount the needle selector unit onto the machine body and clamp them temporarily with fourteen screws on the gate peg side of the stay and the lower holder plate. And secure them after adjustment.

(Mounting dimension of needle selector plate holder)

Mount the needle selector plate holder to the dimension measured when disassembling. Fig. 33 shows the fixed dimension between the needle selector plate holder and the needle bed.

(Mounting dimension of needle selector unit)

Mount the needle selector unit to the distance of 69 mm, which is measured between the side of the rear rail (needle bed) and the needle selector unit with slide calipers.

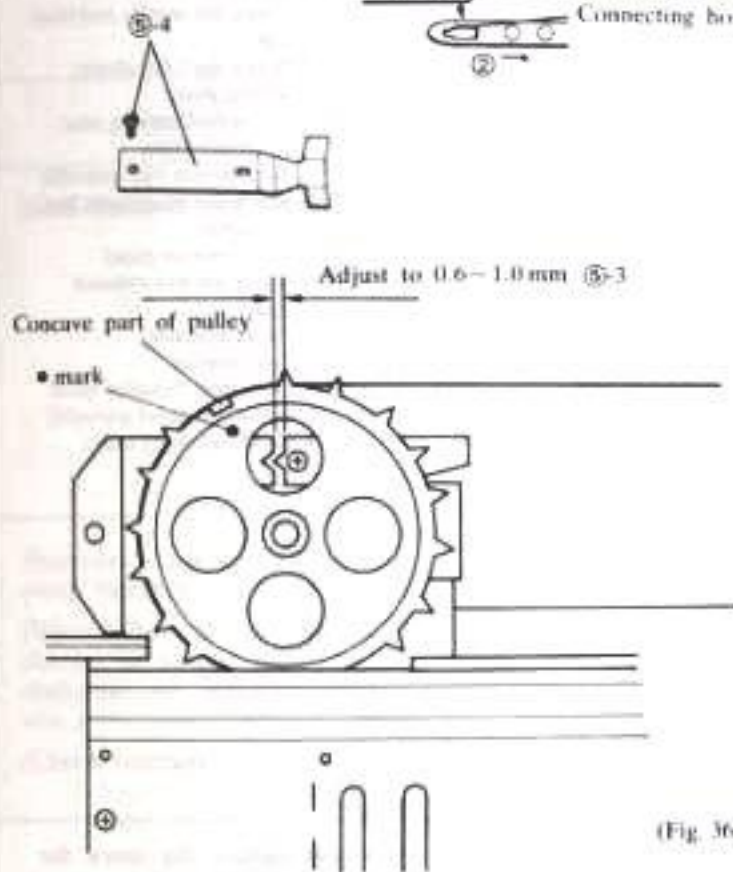
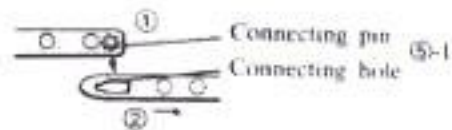

(Fig. 36)

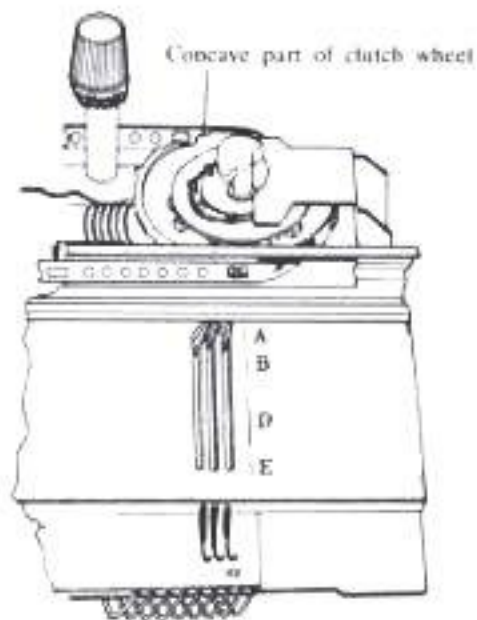

(Fig. 37)

Names of Parts

- ⑤-1 Timing belt
- ⑤-3 Screw for pulley adjusting plate
- ⑤-4 Screw for brake spring

5. Mounting the timing belt

5.1 Put the timing belt over the clutch wheel and the pulley on both sides with the belt connecting pin kept inward.

- * 1. On the pulley side, pass the belt from the front side by fitting the belt connecting pin to the shallow concave part of the pulley.

Note: Put the belt slot to the concave part indicated with the • mark on the pulley.

- * 2. On the clutch wheel side, pass the belt from the front side by fitting the belt connecting hole to the shallow concave part of the clutch wheel.

- 5.2 loosen the left screw for pulley adjusting plate, then the belt is stretched by the spring pressure.
- 5.3 Adjust the pulley adjusting plate to 0.6~1.0 mm like Fig. 36 and fix it with the screw.
- 5.4 Put the belt tension control spring to the pulley shaft and fix them with the screw

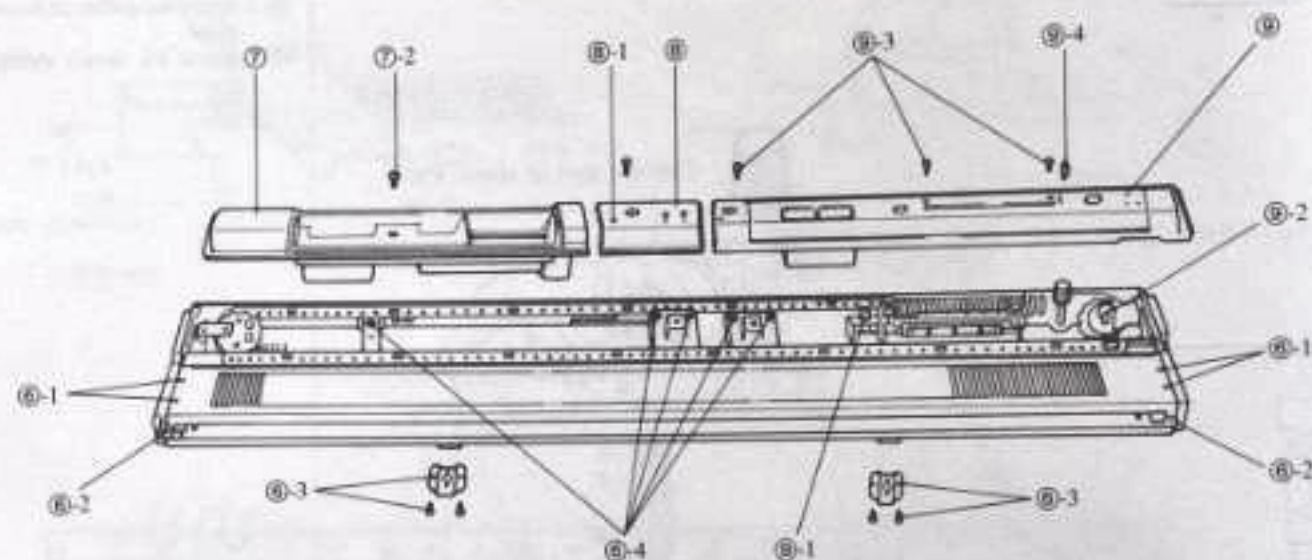

(Fig. 38)

Names of Parts

- ①-1 Screw for needle bed
- ①-2 Screw for needle bed front part
- ①-3 Screw for table clamp setting plate
- ①-4 Screw for carrying case reinforce plate
- ② Accessories box assembly
- ②-2 Screw for accessories box assembly
- ③ Row counter panel
- ③-1 Screw for row counter panel
- ④ Panel assembly
- ④-1 Push button
- ④-2 Direction indicator plate
- ④-3 Screw for panel assembly
- ④-4 Card lock lever knob

6. Mounting the machine body into the case

- 6.1 Mount the machine body into the carrying case lower assembly.
- 6.2 Tighten four screws for needle bed on both sides.
- 6.3 Tighten the screws for needle bed front part
- 6.4 Tighten five screws for carrying case reinforce plate A and B. (See Fig. 38.)
- 6.5 Fix the right and left table clamp setting plates to the case bottom respectively with two screws.
(Be sure to check the front and rear position.)

7. Mounting the accessories box panel

- 7.1 Keep the accessories box at the left side of the machine body.

- 7.2 Take off the accessories box cover and tighten the screw for accessories box.

8. Mounting the row counter panel

- 8.1 Mount the row counter panel and fix it with the screw.

9. Mounting the panel

- 9.1 Insert the push button and the direction indicator plate
- 9.2 Keep the panel at the right side of the machine body.
- 9.3 Fix the panel with three screws.
- 9.4 Put the card lock lever knob to the panel.

INSPECTION OF NEEDLE SELECTOR FUNCTIONS

Function	Standards	How to Check
<p>Hand-operated card feeding</p>	<ol style="list-style-type: none"> 1. The gear must engage when the card feeding knob is pushed down. 2. The card readers must be completely released from the card and the rotary cam when the card feeding knob is pushed down. 3. The card feeding knob turns smoothly. 4. The card roller shaft clicks and stops surely. 	<ol style="list-style-type: none"> 1. Push the card feeding knob to check the gear condition. 2. Check the card readers at the same time as the above item 1. 3. Insert the card and check the feeding condition. 4. Check the card roller at the same time as the above item 3.
<p>Automatic card feeding and clutch function (When the clutch wheel changes its turning direction, clockwise or counterclockwise.) (Clutch function)</p>	<ol style="list-style-type: none"> 1. The card readers completely come off the card roller and the rotary cam. 2. The card roller surely turns and feeds the card by means of the ratchet. 3. After the above mentioned operations, the clutch wheel gets in a condition to turn freely. 4. The clutch wheel turns smoothly. 5. When the clutch wheel turns, the clutch gear sides until it gets in contact with the stopper of the clutch wheel. 	<ol style="list-style-type: none"> 1. Turn the clutch wheel by hand to check the standards listed as the item 1 through 4. (Tactile impression and visual observation) 2. With regard to the standard item 5, be sure to check the rotary cam begins turning when the carriage changes the direction and moves about 54 mm.
<p>Switching of the card lock lever</p>	<ol style="list-style-type: none"> 1. Switching of the card lock lever is smooth. 	<ol style="list-style-type: none"> 1. Switch and check the card stop lever.
<p>Engagement of clutch wheel and rotary cam</p>	<ol style="list-style-type: none"> 1. The clutch wheel properly engages with the rotary cam. 	<ol style="list-style-type: none"> 1. Visual check

HOW TO AJUST THE MACHINE BODY

1. The knitted material is different in gauge and/or in length on its right and left sides.

1. Mounting dimensions of right and left gate pegs are uneven.
(How to measure the mounting distance of gate pegs for the model KH-200)

Cause

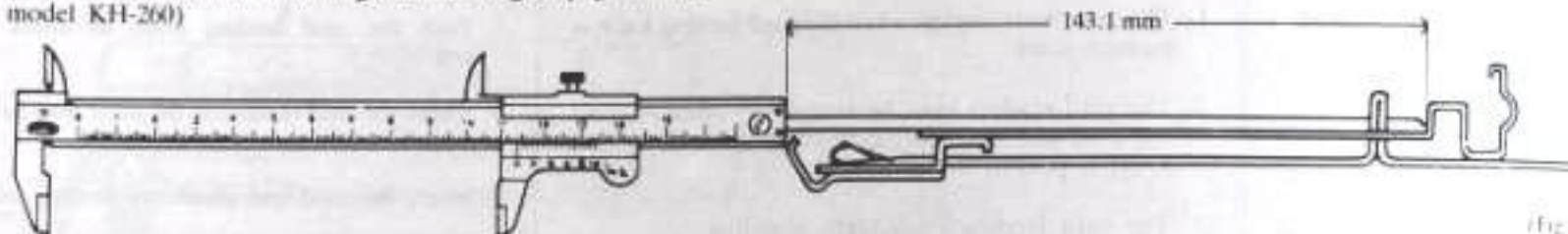

(Fig. 39)

Adjustment

1. Detach the machine body from the case. (See the page 28.)
2. Remove seven screws for stays and table clamp setting plates, provided on the gate peg side.
3. Loosen twenty nuts, attached on the bottom side of the gate peg, with a box screwdriver.
4. Pull three plain needles respectively at each three positions of the needle bed (right, center, and left). Position the gate pegs so that the plain needles may come to midway between them. (Lateral adjustment)
5. Attach and fix the gate pegs with nuts while measuring the mounting distance of 143.1 mm at three positions of the machine body (right, center, and left). (Longitudinal adjustment)

(Measure and adjust the mounting distance of the gate peg with slide calipers before tightening nuts. Use slide calipers as if measuring the depth shown in Fig. 39.)

6. With regard to the mounting distance of the gate peg for old models, measure and adjust it, referring to the following table.
7. After adjustment, carry out the plain knitting with thick yarn thirty rows as setting the stitch dial to ⑤, 114 stitches. And measure the length of knitted material at the 39th stitch on each right and left side. Check the difference in knitting length on each side does not exceed 3 mm.

(Apply a load of 1 kg evenly to the knitted material. The load of 1 kg suitably corresponds to four claw weights on the cast-on comb long.)

(Reference) How to measure the mounting distance of gate pegs for old models.

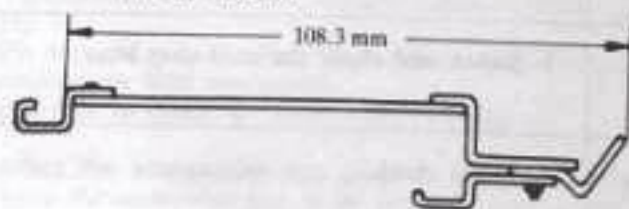

(Fig. 40)

Model	Mounting distance of gate peg	How to measure
KH-585 ~ KH-601-801	108.3 mm	Fig. 40
KH-110, 120	107.4 mm	Fig. 40
KH-811 ~ KH-821	114.35 mm	Fig. 39
KH-831 ~ KH-891	113.2 mm	Fig. 39
KH-230	140.8 mm	Fig. 40
KH-280	126.9 mm	Fig. 39

2. The plain needles fall into the needle bed.

1. The needle retaining spring is broken.

Cause

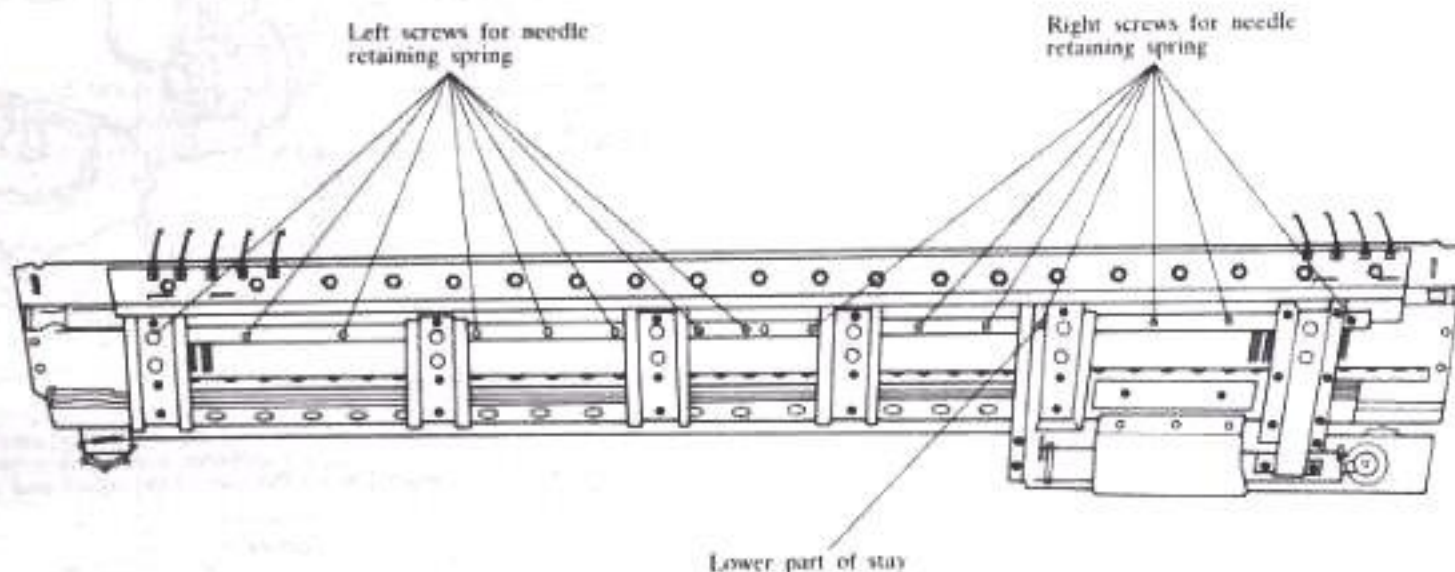

(Fig. 41)

Adjustment

(Removing the needle retaining spring)

1. Detach the machine body from the case. (See the page 28.)
2. Pull out the needle presser bar.
3. Remove left eight screws for needle retaining spring provided near the gate peg, then the left needle retaining spring can be pulled out. Remove the right eight screws, then the right one can be removed. (And remove the screws attached under the center stay and the lower holder plates.)
5. Then the needle retaining spring reinforce plate comes off.

(Mounting the needle retaining spring)

1. Attach the needle retaining spring and the needle retaining spring reinforce plate to the gate pegs and fix the needle retaining spring to the gate pegs with sixteen screws.
2. Bring the plain needles back to the B position.
3. Put the needle presser bar
4. Attach the machine body to the case. (See the page 40.)

3. The right needle selection is not carried out.

(Cause 1)

The timing belt, the clutch wheel, and the pulley are mounted incorrectly.

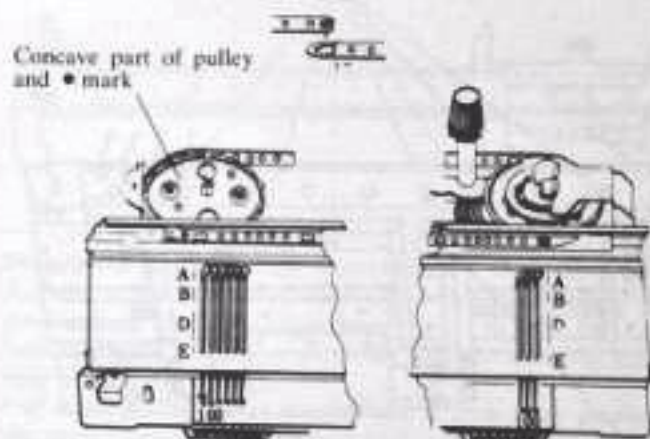

(Adjustment)

Attach the timing belt so that its connecting part may be positioned to the concave part marked with a black point of the pulley and the clutch wheel. (See the page 39.)

(Cause 2)

The rotary cam and the clutch wheel are mounted incorrectly.

(Relative position of clutch wheel and rotary cam)

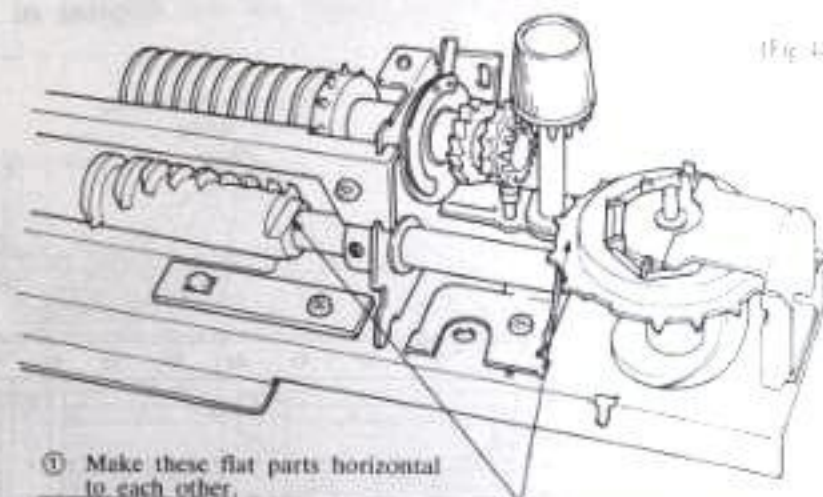

- ① Make these flat parts horizontal to each other.
- ② Turn the clutch wheel clockwise until the clutch gear, provided on its bottom, gets contact with the E position. Under this condition, make the • mark correspond to the flat part of the rotary cam to assemble them.

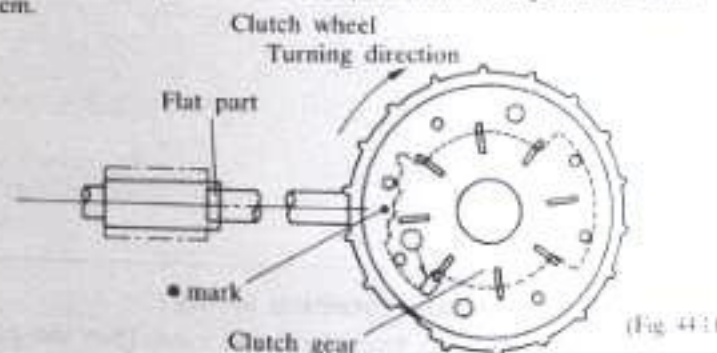

(Adjustment)

- 2.1 Remove the timing belt and the timing belt guide plate, right.
- 2.2 Remove the card reader release cam from the bottom of the clutch wheel.
- 2.3 Turn the clutch wheel clockwise and adjust it to the flat part of the rotary cam while lifting it up slightly.

(Cause 3)

The card reader guide is mounted incorrectly.

(Adjustment)

- 3.1 Set an blank card.
- 3.2 Loosen the screw and move the card reader guide stopper gradually to the left until it resists. Then tighten the screw.

(Check)

1. Take off the card. When the card feeding knob is pushed and released, the card readers should come up.
2. Check each card readers with a thin bar; there should be no play for them.

(Cause 4)

The rotary cam and the card readers are mounted incorrectly.

(Adjustment) Adjustment of rotary cam adjuster collar

- 4.1 Loosen two screws for the rotary cam adjuster collar. (Then the rotary cam moves to the right.)
- 4.2 With no punch card set, lower the card readers fully down by means of pushing down the card feeding knob.
- 4.3 Raise the card readers gradually by means of releasing the card feeding knob. (Pull the timing belt for the rotation of the rotary cam.)
- 4.4 Move the rotary cam to the left so that the tip of a card reader on the left side may locate on the right end of the convex part of the rotary cam as shown in Fig. 46. Then tighten two screws of the rotary cam adjuster collar. (Push the rotary cam adjuster collar fully to the right. See Fig. 47.)

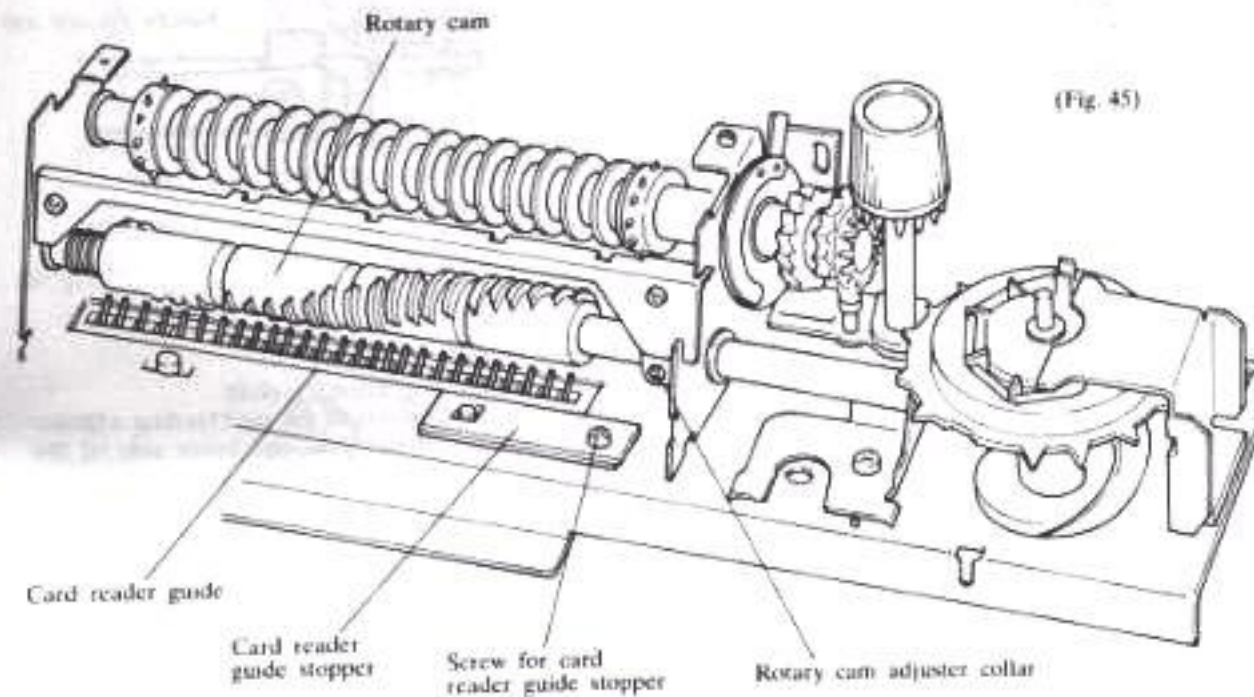

(Fig. 45)

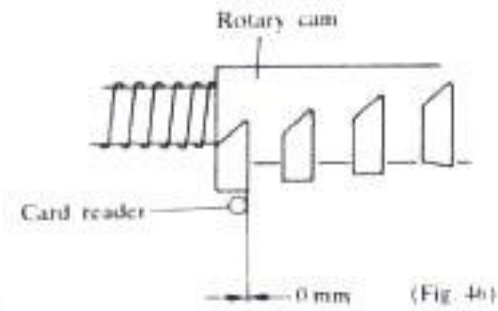

(Fig. 46)

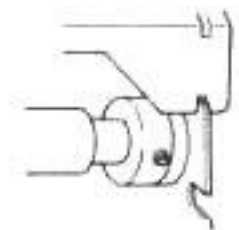

(Fig. 47)

(Cause 5)

The needle selector unit is mounted incorrectly.

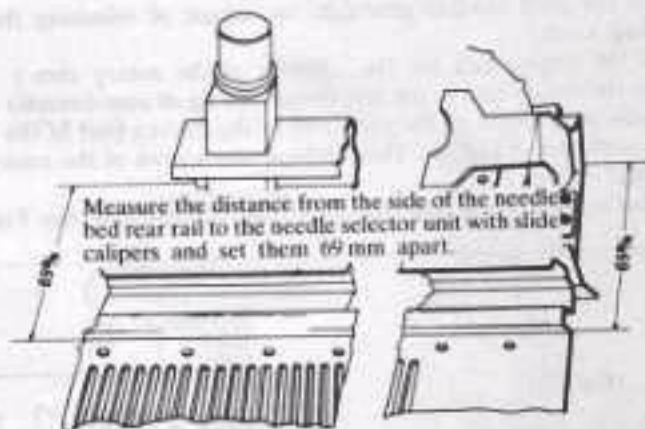

(Fig. 48)

(Adjustment) Adjustment of needle selector unit position

- 5.1 Detach the machine body from the case. (See the page 28.)
- 5.2 Loosen two screws at the center stay, one screw for needle selector plate holder, and two screws for needle selector unit.
- 5.3 Loosen four screws at the right stay, two screws for needle selector plate holder, and three screws for needle selector unit.
- 5.4 Adjust the mounting distances of the needle selector unit and the needle selector plate holder. (See the page 38.)
- 5.5 Tighten each screw after adjustment.

(Cause 6)

The card is not fed correctly.

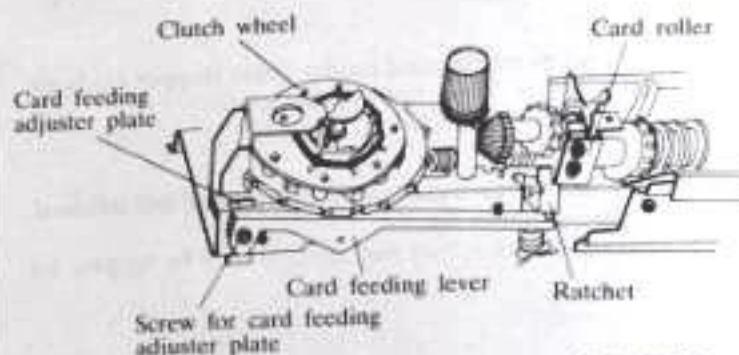

(Fig. 49)

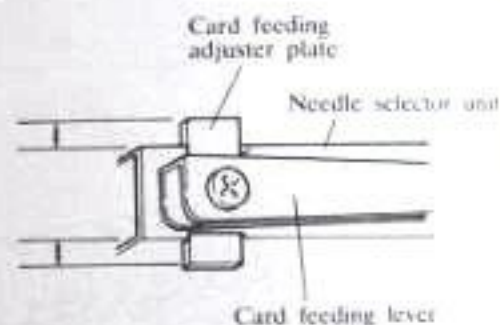

(Fig. 50)

(Adjustment) Adjustment of card feeding lever

- 6.1 Loosen the screw for card feeding adjuster plate.
- 6.2 Fasten the screw so that the appearances of the card feeding adjuster plate are equal length between upper side and lower side of the needle selector unit.

(Check)

1. When the clutch wheel is turned by hand, the card roller should turn smoothly.
2. Set a punch card and change the change knob to the "MC" position. When the carriage is operated with these settings, the card should be fed by one pitch surely.

7. The card is not fed when the card lock lever changed to "▽" (Regular position) from "∇" (Double length position).

(Cause 7)

The intermittent feeding lever does not work smoothly.

(Adjustment)

Provide a slight clearance to the needle selector unit so that the intermittent feeding lever may work smoothly.

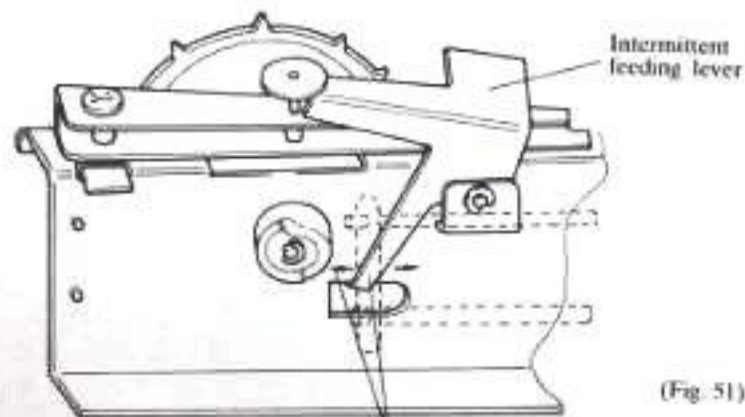

(Fig. 51)

The intermittent feeding lever should not get contact with the needle selector unit; it should work smoothly.

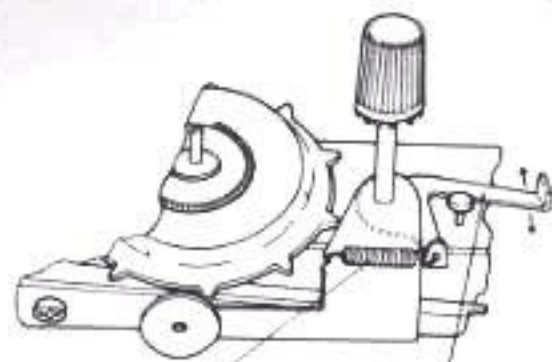

Intermittent feeding lever spring

The change lever should work smoothly. (Fig. 52)

(Cause 8)

The incorrect needle selection with the same needle is carried out because of the bent needle shank.

(Adjustment)

Replace the bad needles.

(Cause 9)

(Adjustment) Lateral adjustment of needle selector plate holder

- 9.1 Detach the machine body from the case. (See the page 28.)
- 9.2 Loosen two screws at the center stay.
- 9.3 Loosen four screws at the right stay.
- 9.4 Loosen four screws for needle selector plate holder attached at the lower holder plates.
- 9.5 Adjust the lateral position of the needle selector unit with the needle selector plate holder.
 - Unnecessary needles come out.
Put the shaft B of the needle selector plate holder into the square hole provided on the left side of the needle bed lower plate. Then tighten each screw while pushing the needle selector plate holder fully to the left.
 - Check the mounting dimension of the separation cam
..... See the page 27.
 - No needle selection is carried out.
Put the shaft B of the needle selector plate holder into the square hole provided on the left side of the needle bed lower plate. Then tighten each screw while pushing the needle selector plate holder fully to the right.
 - Check the mounting dimension of the separation cam
..... See the page 27.

