

SERVICE MANUAL FOR KH-270 ELECTROKNIT.

brother®

CONTENTS

1. PRODUCT CHARACTERISTICS	1	8. CHECKING THE A.C. ADAPTER	14
2. PRODUCT SPECIFICATIONS	1	9. REMOVING ELECTRICAL/ELECTRONIC PARTS AND PC BOARDS	15
3. QUICK TROUBLESHOOTING CHART	2	9.1 Removing the Battery and Control P.C. Board	15
4. NOTES OF CAUTION FOR CHECKING AND REPAIR	4	9.2 Removing the Main P.C. Board	15
5. CIRCUITRY CONFIGURATION	5	10. WHEN CREATED PATTERN DISAPPEAR WITH POWER SWITCH ON	16
5.1 Control PC Board	5	11. DISASSEMBLY, ASSEMBLING, AND ADJUSTMENT OF CARRIAGE	17
5.2 Main PC Board	5	11.1 Disassembling the Carriage	17
5.3 Left Position Sensor PC Board and Right Position Sensor PC Board	5	11.2 Assembling the Carriage	23
5.4 Encoder PC Board	5	11.3 Checking the Carriage Functions —1—	29
5.5 Solenoid PC Board	5	11.4 Checking the Carriage Functions —2—	30
5.6 Relationship between Needle Selector Plate, Solenoid, and Needle Number	6	11.5 How to Adjust the Carriage	31
5.7 The relation between knitting machine & PPD Cartridge	6	11.6 Mounting Dimensions of Each Carriage Cam	34
5.8 Power	7	12. DISASSEMBLY AND ASSEMBLY OF THE MAIN BODY	35
6. TEST PROGRAMS	8	12.1 Disassembling the Main Body	35
6.1 Test 885	8	12.2 Assembling the Main Body	37
6.2 Test 888	9	12.3 How to Adjust the Needle Bed Comb	41
6.3 Test 889	10	13. ADJUSTMENT AND CHECK OF THE NEEDLE SELECTOR MECHANISM	42
7. CHECKING THE NEEDLE SELECTOR	11	13.1 Adjusting the Card Reader Guide Plate	42
7.1 Checking with the Power Switch Turned Off	11	13.2 Adjusting the Rotary Cam Position	42
7.2 Checking with the Power Switch Turned On	11	13.3 Checking the Needle Selector Mechanism	43
7.3 Checking with the Solenoid On	11		
7.4 Checking the Solenoid	12		
7.5 Checking Needle Selection by Test Pattern	13		

1. PRODUCT CHARACTERISTICS

1. **The application of electronics to a pattern knitting device, and automatic needle selection through the internalization of pattern data utilizing a microcomputer.**
2. **Patterns stored in memory may be altered in a variety of ways:**
 - ① The orientation of the pattern may be changed.
 - ② The pattern may be expanded to two times horizontally as well as vertically, and up to four times by expanding the pattern two times in both directions simultaneously.
 - ③ The pattern may be knitted face to face/back to back.
 - ④ Negative and KRC patterns may be knitted by merely switching the pattern variation key.
3. **Large sized patterns may be knitted.**
112 stitches 998 rows x 2 + 112 stitches 246 rows
4. **Original patterns may be knitted through key input.**
5. **Patterns stored in memory are not erased when the power is turned off.**
6. **Original pattern data may be stored or called up with stitch pattern cartridge III.**
7. **Thread lace may be knitted with K carriage.**

2. PRODUCT SPECIFICATIONS

Pitch, number of needles	9 mm, 114 needles
Weight	16 kg
Size	L 1,217 mm x W 241 mm x H 92 mm
Color	White
Needle bed material	Tempered steel can be installed
Knit reader	KL116 may be used
KR-KRC usage	KR260, KRC900 Intersia carriage may be used (KA-2600)
Pattern programming device	PPD-120 may be used
Pattern needle device	Automatic needle selection by internal microcomputer
Voltage-power requirements	AC adapter 7.5V1A

<Accessories>

- Pattern book
- Design sheet

3. QUICK TROUBLESHOOTING CHART

+

Trouble		Origin	Remedy	Notes
K carriage	K carriage does not move easily	1. Carriage cam sliding. Part is out of oil	1. Oil the butt of the needle and the stitch cam	
		2. Needle bed sliding. Part is out of oil	2. Oil front and rear rails of body and carriage	
		3. The sinker plate and gate peg are in contact	3. Correct sinker plate front-rear adjustment	See P.31
		4. The sinker plate is lifting the knitting needle	4. Correct vertical adjustment of sinker plate	See P.31
		5. The gage is too tight	5. Loosen knitting gage	
		6. Poor horizontal adjustment of rotary cam. (Rotary cam is positioned too much to the left.)	6. Correct horizontal adjustment of rotary cam	See P.42
Knitting	Floating stitches. Stitches get tucked.	1. Too much gap between sinker plate and gate peg	1. Correct front-rear adjustment of sinker plate	See P.31
		2. Too much gap between sinker plate and needle	2. Correct vertical adjustment of sinker plate	See P.31
		3. Needle latch not functioning properly	3. Change needle	
		4. The gage is too tight	4. Loosen knitting gage	
	Stitches irregular (uneven) Lateral stripe is produced occasionally	1. Uneven speed in carriage operation	1. Make carriage operation speed constant.	
		2. Poor yarn feed	2. Loosen spring tension of the yarn tension disk	
	Knitting gage of the right needle bed and that of the left is different	1. Attachment of needle bed comb uneven left to right	1. Adjust the needle bed comb position even left to right	See P.41
	The carriage gets stuck while knitting	1. The needle bed is damaged	1. Repair needle bed	
2. The butt of the needle is damaged		2. Replace needle		
When the change knob is set to <KC>, end needle selection is not possible	1. End needle selection cam problem (function is heavy, worn)	1. Replace end needle selection cam	See P.21, P.23	
Needle selection	Wrong needle is selected	1. Encoder sensor P.C. board problem	1. Check encoder sensor P.C.B. by TEST 885	See P.8
		2. Right/Left position sensor problem	2. Check Right/Left position sensor P.C.B. by TEST 885	See P.8
		3. Main P.C. board problem	3. Replace the Main P.C. board when all other possibilities have been checked and no problem discovered	See P.15
		4. Needle selector mechanism problem	4. Check needle selection mechanism and needle selector solenoid	See P.42
		5. Carriage problem	5. Check carriage	See P.29
		6. Power problem	6. Exchange AC adapter	
		7. Operation problem	7. Operate correctly	

Trouble		Origin	Remedy	Notes
Needle selection	The same needle does not come out	1. The butt or shank of needle bent	1. Replace needle	
		2. Left-right measurement problem between rotary cam lever and rotary cam	2. Correct right-left adjustment of rotary cam (needle selection mechanism)	See P.42
	Unnecessary needles come out at 6 cycles	1. There is grease between the needle selector plates.	1. Wipe grease off needle selector plate	
		2. The N.S.P. operation lever is squeezed between the operation lever presser and the rotary cam holder body N.S.P. operation lever does not move easily.	2. Replace needle selector unit	See P.36. P.37
		3. Needle bent or broken	3. Replace knitting needle	
		4. Hook of needle selector plate spring is making contact with other needle selector plates	4. Correct to hook the needle selector spring	
	Knitting needle not selected at 6 cycles	1. The butt or shank of needle bent	1. Replace knitting needle	
		2. Holes in needle bed worn and enlarged	2. Replace needle bed	
	No needle selection in 12th cycle	1. The rotary cam lever remains at lower position.	1. Lubricate the card reader guide plate	
		2. The position of card reader guide plate is too much to the left.	2. Correct horizontal adjustment of card reader guide plate	See P.42
		3. Rotary cam is out of adjustment horizontally. Needle selector plate travel is too short (Rotary cam is positioned too much to the right.)	3. Correct horizontal adjustment of rotary cam	See P.42
		4. Needle selector solenoid remains power on.	4. Check needle selector solenoid	P.11, 12
	Unnecessary needles come out at 12th cycles	1. The rotary cam lever remains at upper position	1. Lubricate the card reader guide plate	
		2. Rotary cam is out of adjustment horizontally, Needle selector plate travel is too large (Rotary cam is positioned too much to the left.)	2. Correct horizontal adjustment of card reader guide plate	See P.42
		3. Needle selector solenoid remains power off.	3. Check needle selector solenoid	P.11, 12
	Needle selection position is off by 12 stitches	1. The position sensor is out of adjustment	1. Correct voltage adjustment of position sensor and mounting position	See P.8
		2. Connection between belt and carriage connecting plate at carriage forward travel opening is bad	2. Replace the connecting plate. Replace the belt pulley brake (Friction plate spring)	See P.21, 23
		3. Belt connecting hole is damaged	3. Replace the belt	See P.40
4. Carriage and belt sensor circuitry system is bad		4. Replace the encoder PC board or replace the main PC board	P.15	
5. Slit disc is damaged		5. Replace the slit disc		

4. NOTES OF CAUTION FOR CHECKING AND REPAIR

In order to avoid secondary damage, please pay attention to the following points;

- (1) When assembling or disassembling the machine, always ensure that the AC adapter is unplugged from the socket.
- (2) Be sure not to pull the plug by the cord when disconnecting it from the socket.
- (3) Tighten nuts and screws down securely.
- (4) Be sure not to lose any nuts, screws, or washers, and ensure not to leave any of them in the machine during assembly. These can be the cause of shorts in the electrical circuitry.
- (5) Do not damage the cords or PC boards with the soldering iron.
- (6) The electrical parts used in the machine can be damaged by static electricity. Therefore, be sure to handle PC boards by the edges and to refrain from allowing your hands to come into direct contact with parts.
- (7) When transporting PC boards, it is best to wrap them in aluminum foil or in an anti static electricity bag. When transporting the main PC board assembly, always ensure that the lithium battery has been removed. Never wrap the assembly with the lithium battery still attached. Polyethylene and styrene can cause static electricity and should not be used for wrapping.
- (8) After the completion of assembly or disassembly, check to ensure that all connectors are properly connected and that the equipment operates normally.
- (9) The main power should be the same as the rating of the machine.
- (10) Ensure that the positive and negative terminals of the lithium battery are not shorted.
- (11) Check the exclusive adapter for knitting machine.
(If it is used different adapter, knitting machine is broken.)

5. CIRCUITRY CONFIGURATION

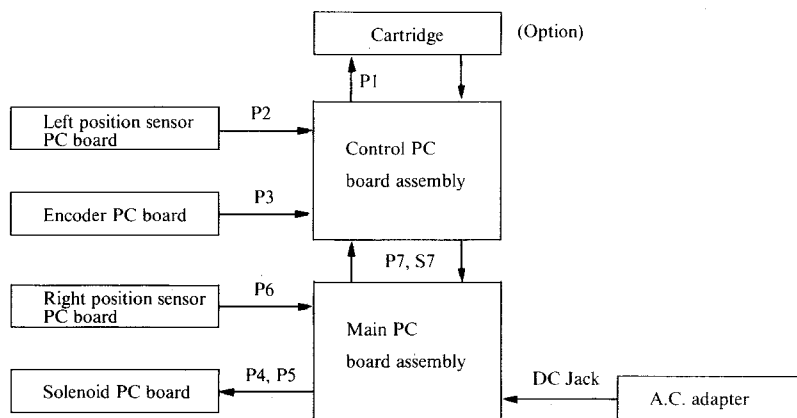

Fig. 5-1 shows the circuitry configuration of the KH-270

5.1 Control PC Board

The control PC board is the main control portion of the equipment. It is comprised of the microcomputer, memory, and voltage regulator, etc.

5.2 Main PC Board

The main PC board is the keyboard portion. It is comprised the lamp (LED and 7 segment LED), switch, and solenoid driver, etc.

5.3 Left Position Sensor PC Board and Right Position Sensor PC Board

The left and right position sensor PC board are what send out the carriage position signal. It is connected to the control PC board by a connector (P2, P6).

The position sensor signal (pin 3 of P2, P6) is normally DC 1.6 ~ 1.8V, but when the K carriage sensor magnet approaches the position sensor, it becomes DC 3.5V or more.

5.4 Encoder PC Board

The encoder PC board emits signals required in the detection of the direction and amount of carriage movement and in solenoid selection. It is connected to the control PC board by a connector (P3).

The V_1 (pin 4 of P3), V_2 (pin 3 of P3) signals are configured as shown in figure 5-2 below.

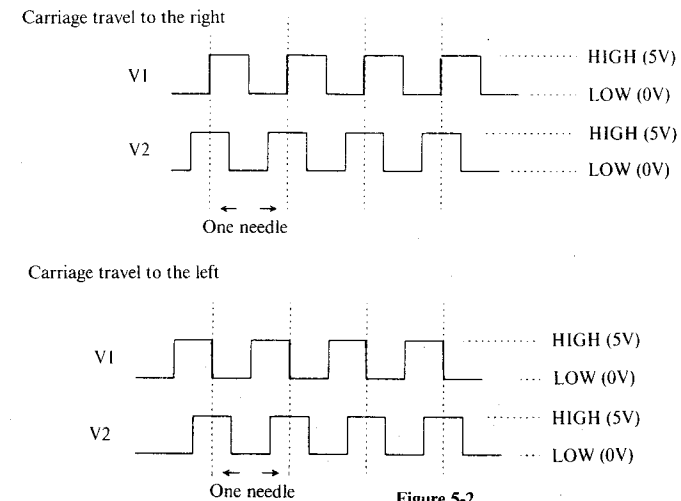

Figure 5-2

5.5 Solenoid PC Board

The solenoid PC board is a PC board which is acted upon by the needle selector device. It is connected to the control PC board assembly by a connector (P4, P5).

There are 12 needle selector solenoids, with numbers on them, counted sequentially from left to right. There are 6 needle selector plates, the relationship to the rotary cam of which is given in figure 5-3 below.

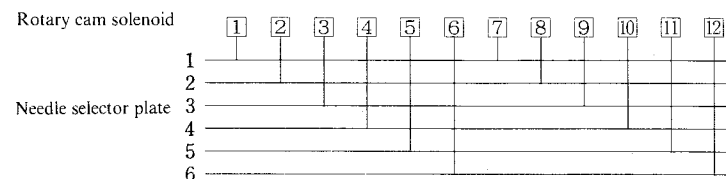

Figure 5-3

5.6 Relationship between Needle Selector Plate, Solenoid, and Needle Number

Carriage travel to the right

Needle selector plate	Solenoid	Yellow needle numbers (left)						Green needle numbers (right)				
1	1		48	36	24	12	1	13	25	37	49	
2	2		47	35	23	11	2	14	26	38	50	
3	3		46	34	22	10	3	15	27	39	51	
4	4		45	33	21	9	4	16	28	40	52	
5	5	56	44	32	20	8	5	17	29	41	53	
6	6	55	43	31	19	7	6	18	30	42	54	
1	7	54	42	30	18	6	7	19	31	43	55	
2	8	53	41	29	17	5	8	20	32	44	56	
3	9	52	40	28	16	4	9	21	33	45		
4	10	51	39	27	15	3	10	22	34	46		
5	11	50	38	26	14	2	11	23	35	47		
6	12	49	37	25	13	1	12	24	36	48		

Carriage travel to the left

Needle selector plate	Solenoid	Yellow needle numbers (left)						Green needle numbers (right)					
1	1		54	42	30	18	6		7	19	31	43	55
2	2		53	41	29	17	5		8	20	32	44	56
3	3		52	40	28	16	4		9	21	33	45	
4	4		51	39	27	15	3		10	22	34	46	
5	5		50	38	26	14	2		11	23	35	47	
6	6		49	37	25	13	1		12	24	36	48	
1	7		48	36	24	12		1	13	25	37	49	
2	8		47	35	23	11		2	14	26	38	50	
3	9		46	34	22	10		3	15	27	39	51	
4	10		45	33	21	9		4	16	28	40	52	
5	11	56	44	32	20	8		5	17	29	41	53	
6	12	55	43	31	19	7		6	18	30	42	54	

5.7 The Relation between Knitting Machine & PPD Cartridge

○ Possible × impossibility

The relation between KH270 & PRO Cartridge

Cartridge name	Stitch Pattern Cartridge II (for PPD110)		Stitch Pattern Cartridge III (for PPD120)		
	930	940	930	940/270	900
Cartridge Mode	930	940	930	940/270	900
Load Cartridge → KH270	○ (16 pages)	○ (1 page)	○ (16 pages)	○ (1 page)	○ (8 pages)
Save KH270 → Cartridge	×	○ (1 page)	×	○ (1 page)	×

The relation between KH900 & PPD Cartridge

Cartridge name	Stitch Pattern Cartridge II (for PPD110)		Stitch Pattern Cartridge III (for PPD120)		
	930	940	930	940/270	900
Cartridge Mode	930	940	930	940/270	900
Load Cartridge → KH900	×	×	×	×	○ (8 pages)
Save KH900 → Cartridge	×	×	×	×	○ (8 page)

The relation between KH940 & PPD Cartridge

Cartridge name	Stitch Pattern Cartridge II (for PPD110)		Stitch Pattern Cartridge III (for PPD120)		
	930	940	930	940/270	900
Cartridge Mode	930	940	930	940/270	900
Load PPD + Cartridge → KH940	○ (16 pages)	○ (1 page)	○ (16 pages)	○ (1 page)	○ (8 pages)
Save KH940 → PPD + Cartridge	×	○ (1 page)	×	○ (1 page)	×

Stitch Pattern Cartridge EXTRA's
(Built-in 853 patterns, Option)

KH model	KH940	KH270	KH900
Load (Cartridge → KH)	○ (32 pages) * with PPD	○ (32 pages)	○ (32 pages)
Save (KH → Cartridge)	×	×	×

* Remarks

1. KH940 can not knit mixtured patterns. (Tuck & Lace patterns/Woven-lace patterns)
2. KH270 can not knit mixtured pattern and lace patterns.

5.8 Power

The power uses exclusive adapter.

The generating power of the adapter is DC7.5V and 1A ~ 1.2A.

The generating power of the adapter which is changed into 5V by voltage regulator in the main PC board of the knitting machine, is supplied to computer, memory, and solenoid driver, etc.

Polarity of the DC plug; outside _____ (+)
 inside _____ (-)

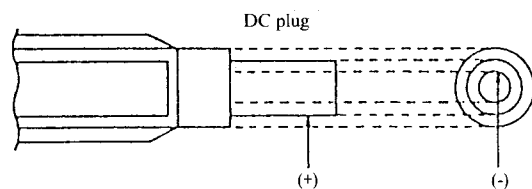

6. TEST PROGRAMS

6.1 Test 885 Needle Position Detect Circuit Test

- **Step 1** —Display right or left position signal voltage. The computer will report that it has detected either the K carriage sensor magnet.

■ Test procedure

- (1) Turn the power switch on.
- (2) Turn the display off by pushing the **CE** key.
- (3) Input the digits **8 8 5** and push the **STEP** key.
- (4) The voltage of the left position signal will be indicated in the display (for example, **1 7 6** indicates 1.76V). A yellow lamp will light, indicating that the left side is being checked. When there is no carriage sensor magnet in front of the sensor, a voltage of 1.76V or 1.92V will be indicated. At this point, if the VR on the left position sensor PC board is turned, the voltage displayed in the display will also change.

*Note:

In the event that the voltage displayed in the display does not fall between 1.76V and 1.92V, adjust via the VR on the left position sensor PC board. This adjustment should be done as follows: first, turn the VR slowly until 1.92V is displayed, then turn it slowly to the left until 1.76V is displayed and stop.

*When there is a problem

When adjustment cannot be effected, replace the position sensor PC board and attempt the above adjustment again.

- (5) Place the K carriage sensor magnet in front of the sensor (with the change knob on <KC>). At this time, the voltage indicated in the display should be 3.36V or over. When voltage is 3.04V or over and the computer detects the K carriage, a "1" will be displayed in the memo display.

If the direction of carriage movement changes (from right to left (when the yellow lamp is on), it will turn off. Check the both of sensor magnet.

- (6) Push the **GREEN** key.
The voltage of the right position sensor signal will be displayed. The green lamp will light indicating that the right side is being checked.
- (7) Using the sequence given in (4)-(5) above, check the conditions of the K carriage on the left.

*Note:

To recheck the left side, pushing the **YELLOW** key will put the equipment in the condition given in (4) above.

When there is no problem by performing the checks given above. Push the **STEP** key, and the voltage display on the display well as the YELLOW,

GREEN, and START lamps will be turned off. Then, the step 2 test will begin.

*When there is a problem

By performing the checks given above, check the mounting position of the position sensor PC board horizontally and vertically to see that each have the proper voltages. If they do not, replace the position sensor PC board.

- **Step 2** —This is to check to see whether, of the needle position detect circuit signals, the V_1 , V_2 , and iRQ (count edge) signals have been properly sent to the computer.

- (10) Move the carriage forward and backward one time (20 needles or more). If a problem is noted during step 2, an "E" will be displayed in the memo display, and an error digit in the display. When there is an error digit in the display, the step will proceed no further.

If the **STEP** key is pressed, the step 2 test will be repeated.

Error digit has error digit "E3" only in this step.

E3: the V_1 , V_2 signals or iRQ signal are not sent correctly to the Main P.C. board assembly when the carriage is moving.

When other than "E3"

The condition of the V_1 , V_2 signals will be indicated in a 3 digit display.

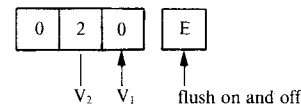

- 0: proper condition.
- 1: The signal remains High
- 2: The signal remains Low

***When there is a problem (the condition of V₁, V₂ signals is indicated in the displays.)**

After the check is completed, if the condition of V₁, V₂ signals is indicated in the displays, replace the encoder PC board, then perform the check again starting with step. 1.

Carriage traveling to the right

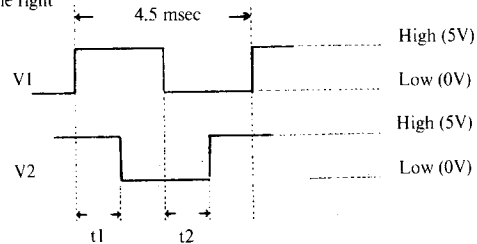

Carriage traveling to the left

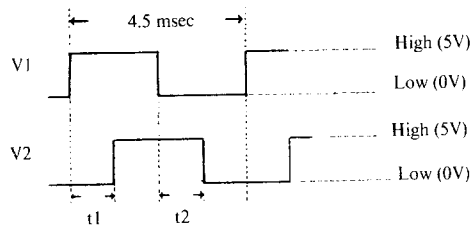

When carriage speed is at 2m/s, and t1 and t2 are both over 225 μsec.

If no problems are noted in step 2, a buzzer will sound, and the READY lamp will light.

***When there is a problem**

After the check is completed, if the READY lamp does not light, or if an error digits is not indicated, replace the encoder PC board. After replacement perform the check again starting with step one.

6.3 Test 888 Memory Test

The computer will test the memory. The execution of this test will clear the memory of the entirety of its contents.

■ Test procedure

- ① Turn the power switch on and turn the display off by pushing the **CE** key.
- ② Input the digits **8 8 8** and push the **STEP** key.
55 (HEX) will be written into all memory fields and a check will be performed to ensure that 55 has been written. Then, AA (HEX) will be written, and a check performed to see that AA has been written into all fields. When these checks are passed, a 0 is written into all fields of the memory and the READY lamp lights. If the checks are not passed, an "E" will indicate in the memo display. Pushing the **STEP** button repeats this test.

*Note

The check requires about 30 seconds for completion.

Be sure not to turn the power switch off before it is completed.

*If there is a problem

If an error is registered on the display, replace the main PC board.

6.4 Test 889 Display Key Test

- **Step 1** — Indicator lamps all blink.

- ① Turn the power switch on.
- ② Push the **CE** key, turning the display off.
- ③ Input the digits **8 8 9**, and push the **STEP** key. In the display and in the memo display window **8 8 8** and **8**, and the remaining lamps (LEDs) will all light on.
- ④ Press the **STEP** key. The display and the lamps will all go off, and the step 2 test is ready. Check to ensure that the keys are functioning properly.
- ⑤ If a key is pushed, the number for that key should be displayed in the display. The numbers for each of the keys is given in chart 2.

***If there is a problem**

There is a problem in either the main PC board or in the control PC board. Replacing the main PC board and repeat the "889" test program. If the same problem reoccurs, that will indicate that there is a problem in the control PC board, so replace it. In this event, the former main PC board should be normal.

Chart 2

Indica-tion	Key	Indica-tion	Key	Indica-tion	Key
20	0	34	Green	58	◀
21	1	35	△	59	SELECTOR 2
22	2	36	▽	90	VARIATION 1
23	3	37	M key	91	VARIATION 2
24	4	38	C	92	VARIATION 5
25	5	39	SELECTOR 1	93	VARIATION 3
26	6	50	INPUT	94	VARIATION 4
27	7	51	CHECK	95	VARIATION 6
28	8	52	(((((▶	96	VARIATION 7
29	9	53	MEMO	97	R
30	STEP			98	S
31	CR	55	□	99	START
32	CE	56	■	43	LOAD
33	Yellow	57	▶	45	SAVE

7. CHECKING THE NEEDLE SELECTOR

7.1 Checking with the Power Switch Turned Off

- ① Set the K carriage change knob to <KC>, and put all of the needles in position B.
- ② Turn the power switch off, and move the K carriage to check all, the needles should be selected to position D.

***Note:**

The above check should be performed with the carriage traveling right, left, and at high speed and at low speed.

***If there is a problem**

Then it will be in the needle selector mechanism of the main body or in the carriage needle selector mechanism.

7.2 Checking with the Power Switch Turned On

- ① Set the K carriage change knob to <KC>, and put all of the needles in position B.
- ② Turn the power switch on, and push the **MEMO** key. The **MEMO** key lamp should light.

***Note:**

If the **MEMO** key lamp does not light when the **MEMO** key is pushed, turn the pattern number lamp on after turning the selector (1) key on by pushing the **STEP** key. Input pattern number 100 (or any of the others from 1-288 or 881-884), push the **STEP** key twice, and push the **MEMO** key once again when the READY lamp comes on.

- ③ Select needles after the K carriage has passed the turn mark from the outside. At this point, the needles should all be selected to position B.

***Note:**

The above check should be performed with the carriage traveling right, left, and at high speed and at low speed.

***If there is a problem**

If there are needles selected to position D, perform the check given in 7.3.

7.3 Checking with the Solenoid On

- ① Remove the two operation panel screws. While holding up the left side of the panel and sliding the panel toward the left, remove it from the main body with connectors on.
(*Place the removed panel on the rear of the main body case.)
- ② Remove the three cord cover screws and the cord cover.
- ③ Set the K carriage needle change knob to <KC>, and put all the needles in position A.
- ④ Turn the power switch on, and push the **MEMO** key (as in 7.2 ②).
- ⑤ Move the K carriage past the turn mark from the outside, and then move it from right to left. The armatures should all remain in the down position.

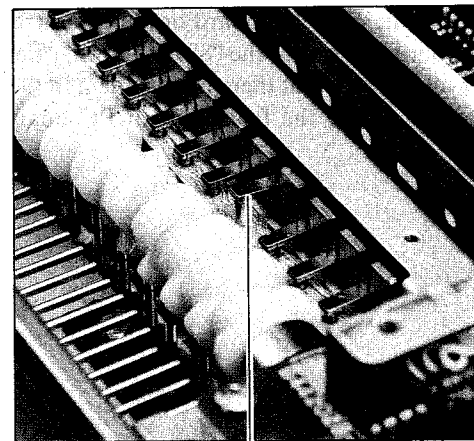

Picture 7-1

The fourth armature from the right is out of position.

***If a problem is found in the 7.2 check**

If a problem is found during the 7.2 check but the 7.3 check produced none, it will indicate a problem in either the needle selector mechanism of the main body or in the carriage needle selector mechanism (refer to 13 on P.42 and 11.3 on P.29).

***If a problem is found in the 7.3 check**

It will indicate a problem in the electrical circuitry. Check this with the test program given in chapter 6 (885, 888). If this does not produce the answer, perform the check in 7.4 (the example shown in the picture is a solenoid no. "9" problem).

7.4 Checking the Solenoid

- ① Turn the power switch off, and disconnect connectors S4 and S5 (P4 and P5 on the main PC board).

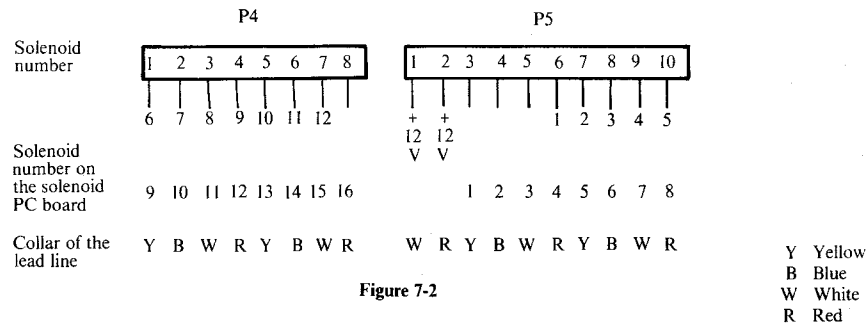

- ② Resistance should be within 100 - 123 Ω . If it is not, there is a problem, which may be found with the check given below. If no problem is found in the resistance values, perform the check given in 7.5.
- ③ Disconnect the needle selector solenoid unit. Check the resistance values of the places which correspond to the solenoids on the solenoid PC board which were found to be bad. The resistance value of the solenoid coil should be between 100 - 123 Ω , the resistance value of the solenoid signal cord should be 0, and the resistance value of the metal portion of the main body and the solenoid should be $\infty\Omega$ (refer to figure 7-3).

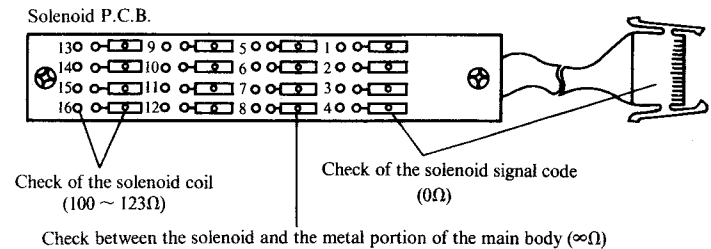

*If there is a problem

If a problem is found in a check between the solenoid coil and the solenoid chassis, replace the solenoid. If a problem is found when checking the solenoid signal cord, replace the solenoid signal cord.

7.5 Checking Needle Selection by Test Pattern

Pattern numbers 1 through 288 are internalized, but other than that, there are also 881 through 884 which are test patterns. The pattern for each of these is given in figure 7-4. The test is performed according to the following procedure.

- ① Put a sufficient number of needles in position B.
- ② Turn the power switch on and push the selector (1) key.
- ③ Push the STEP key, and then the CE key. Then, enter the digits 881-884, and push the STEP key twice. The READY lamp should light.
- ④ Turn the variation (4) (double length) switch on, and set the K carriage change knob on <KC>.
- ⑤ Select needles after passing the K carriage from the outside of the turn mark. The needle selection should change after every other pass.

○ Test patterns



881: 1x1 alternative needle selection

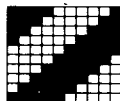

882: 5x5 alternative needle selection

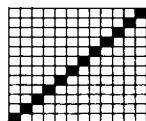

883: 1/12 needle selection



884: 1/5-5/5 needle selection

Figure 7-4

8. CHECKING THE A.C. ADAPTER

KH-270 is uses exclusive A.C. adapter.

As the D.C. output of the exclusive A.C. adapter is 9.5V ~ 14V in no resistance, follow the test procedure:

• Test Procedure

- (1) Turn off the power switch of the knitting machine. Pull out the A.C. adapter from the knitting machine and the outlet.
- (2) Check that the voltage of the outlet is within $\pm 10\%$ of the rated input voltage. (If it is less than -10% of the rated input voltage, the knitting machine can not work. If it is more than $+10\%$ of the rated input voltage, the knitting machine and the A.C. adapter may run hot and this is dangerous.)
- (3) If the voltage of the outlet is appropriate, plug the A.C. adapter into the outlet and check that the D.C. output is 9.5V ~ 14V.

Take care not to mishandle the plus and minus terminals of the tester. (and not to shortcircuit them.)

*If the D.C. output is not 9.5V ~ 14V, replace the A.C. adapter with the new one.

9. REMOVING ELECTRICAL/ELECTRONIC PARTS AND PC BOARDS

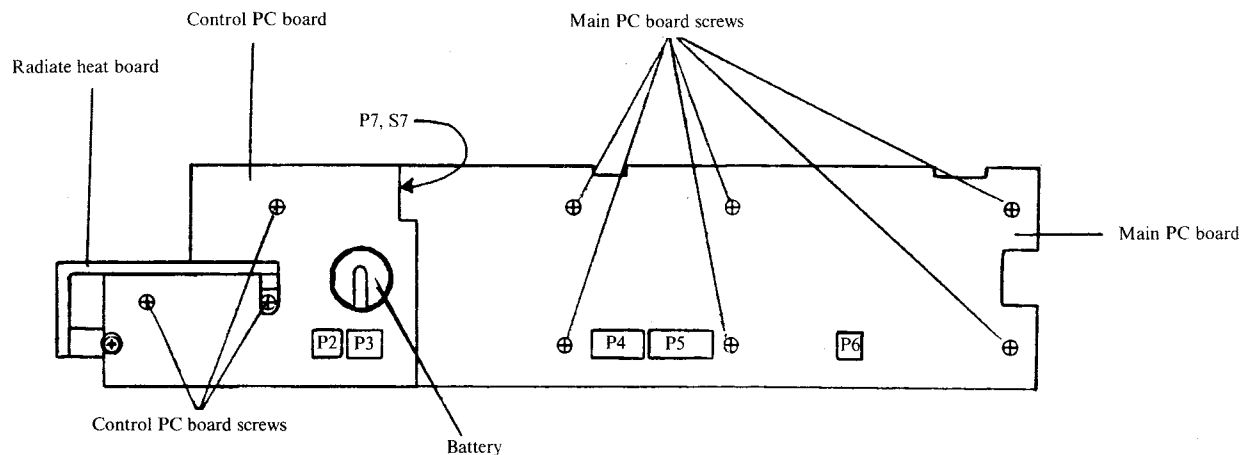

Figure 9-1

1. Removing the battery and Control P.C. Board

- ① Removing the Pattern case whole unit after removing the adapter.
- ② Disconnect all 5 of the connectors of the Control PC board and Main PC board (P2, P3, P4, P5, P6).
- ③ Removing the three screws of the Control PC board. (Figure 9-1)
- ④ Disconnect the Control PC board from the Main PC board as raise it horizontally. (Remove the P7 and S7)
- ⑤ Dissolve the solder on the lead of the battery with a solder iron, so remove the battery.

***CAUTION**

Pay attention to be hot the radiate heat board soon after power off.

On removing the Control PC board, do not give a force on the radiate heat board.

Please, try to run TEST PROGRAM "888" in order to clear the memory (RAM) after assembling the pattern case whole unit.

2. Removing the Main P.C. Board

- ① After remove the Control PC board, remove the eight screws of the Main PC board.
- ② In order to remove the screws, remove the Main PC board and Keys, so invert the pattern case whole unit.

10. WHEN CREATED PATTERN DISAPPEAR WITH POWER SWITCH ON

“E” blinks in the memo display and the created pattern disappears when entering created pattern.

In this case, the battery is consumed up (the voltage is dropped less than DC 2.5V). Or, there is something damage in the memory (SRAM) for created pattern. So that, check both the battery and the main P.C. board according to following steps.

***Note**

In case of KH-270, if the battery is consumed up, or, there is some damage in the memory (SRAM) which is cleared automatically without blinking of “888”.

And if power switch off or disconnect the cartridge while is road from cartridge, the memory is cleared automatically.

- (1) Remove the Main PC board. Then measure the DC voltage between terminals of the battery with a circuit tester.
- (2) If the voltage of battery is less than DC 2.5(V), the battery is out of order. So replace the battery.

If the voltage of the battery is DC 2.5(V) or more, the battery is normal. Then, try the TEST PROGRAM “888” for checking the memory (RAM) circuit of created pattern. If “E” is indicated in the memo display, there is problem on the memory circuit so replace the Control PC board.

11.1 DISASSEMBLING THE CARRIAGE

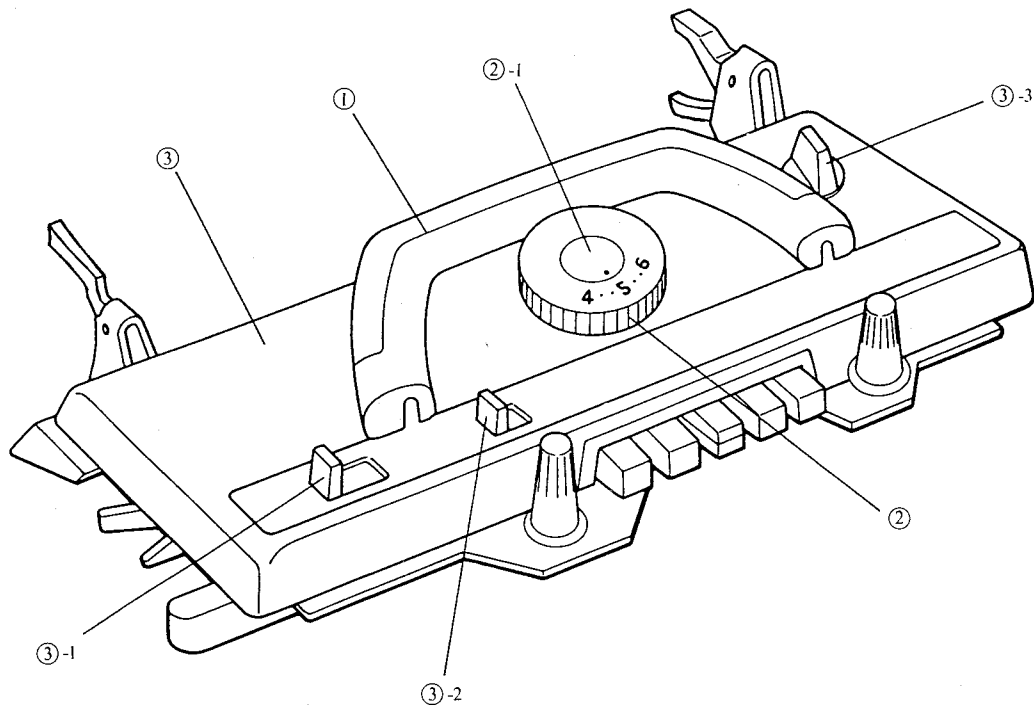

Names of Parts

- ① Handle
- ② Stitch dial
- ②-1 Stitch dial cap
- ③ Carriage cover
- ③-1 H.L.C. knob
- ③-2 Plain lever knob
- ③-3 Change knob

(Fig. 1)

1. Removing the carriage handle

1.1 Remove both handle screws on right and left sides while keeping the handle down. Then the handle can be taken off the carriage.

2. Removing the stitch dial

- 2.1 Pull off the stitch dial cap upward.
- 2.2 Remove the fastening screw and pull off the stitch dial upward.

3. Removing the carriage cover

- 3.1 Loosen and remove both right and left carriage cover clamp screws from the bottom of the carriage. (See Fig. 4)
- 3.2 Remove carriage cover upward. Then the H.C.L. knob, the plain lever knob and the change knob, will come off.

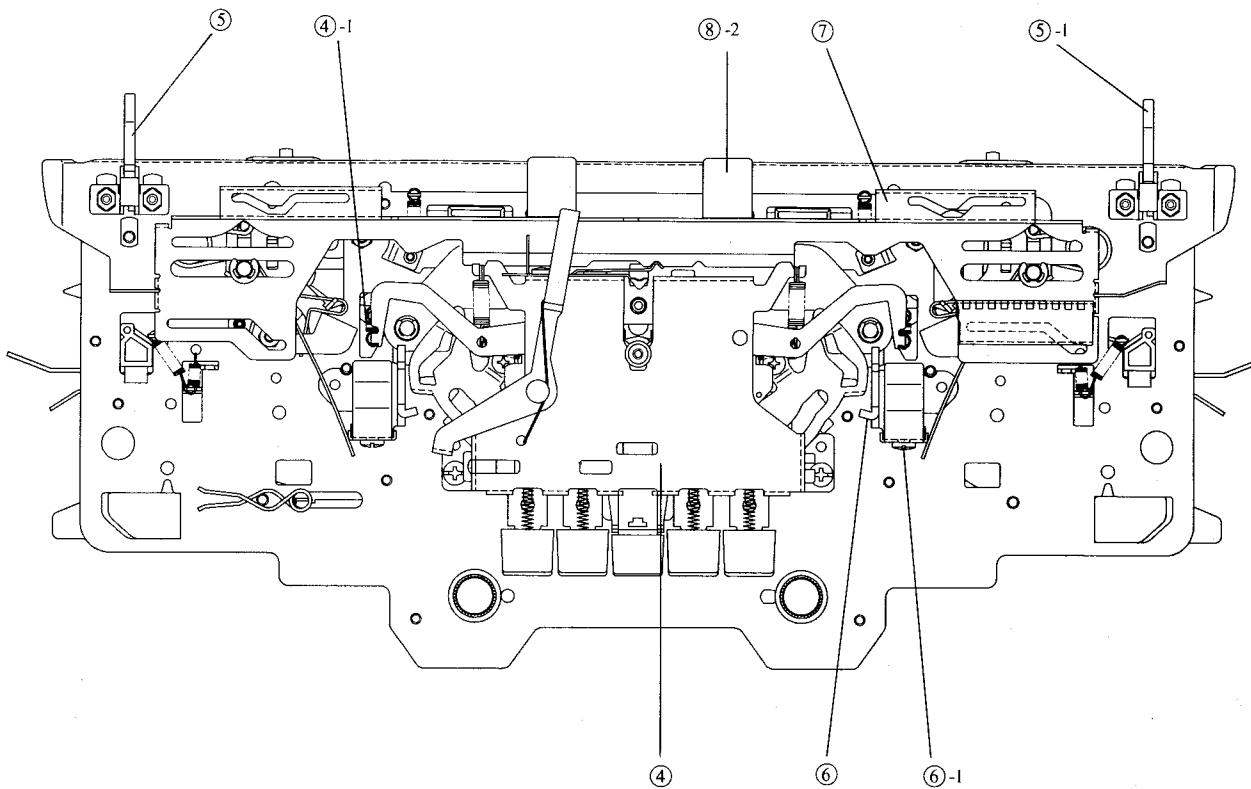

Names of Parts

- ④ Cam button unit
- ④-1 Raising cam change spring
- ⑤ Knit leader tripper
- ⑤-1 Row counter tripper
- ⑥ Handle setting base
- ⑥-1 +-screw 3.57 x 4
(For handle lock spring)
- ⑦ Upper slide plate assembly

(Fig. 2)

4. Removing the cam button unit

- 4.1 Remove the right and left raising cam change springs from the raising cam calking pins with the work hooks.
- 4.2 Remove two screws which clamp the cam button unit.
- 4.3 Remove the cam button unit by pulling it forward and lifting it up.

5. Removing the knit leader tripper and the row counter tripper

- 5.1 Remove each two screws clamping the knit leader tripper and the row counter tripper from the bottom of the carriage.

6. Removing the handle setting base

- 6.1 Loosen the right and left screws to remove both handle lock springs.
- 6.2 Remove screws on both sides to detach the handle setting base.

7. Removing the upper slide plate

- 7.1 Remove the snap rings for the change knob shaft and the carriage calking shaft which is located on the left side with a slotted screwdriver.
- 7.2 Remove the upper slide plate by lifting up its both sides simultaneously.

8. Removing the needle selection change lever spring

8.1 Remove the right and left needle selection change lever springs from the carriage rear plate.

8.2 Pull up and remove the right and left magnet holder.

9. Removing the connecting plate spring

9.1 Pull up and remove the right and left connecting plate spring.

10. Removing the rear plate

10.1 Pull up and remove the rear plate.

11. Removing the tuck cam operating plate

11.1 Remove two tuck cam springs from calking pins.

11.2 Pull up and remove the presser ring and the right and left tuck cam operating plates.

12. Removing the change plate A and B

12.1 Remove the right and left MC cam springs from the pin.

12.2 Remove the change plate spring from the change plate.

12.3 Remove the change plate A spring from the change plate.

12.4 Remove the change plate B spring.

12.5 Remove the nut of change plate guide collar with a 6 m/m box driver to detach the change plate guide collar.

12.6 Pull up and remove the change plate A and B.

13. Removing the push-up change plate

13.1 Remove the screws of push-up change plates, right and left, and also the collars placed under them.

13.2 Pull up and remove both push-up change plates.

14. Removing the cam change plate

14.1 Remove the valve cam E springs from the carriage calking pin and the valve cam E.

14.2 Remove the right and left cam change plates by loosening and removing their nuts.

15. Removing the valve cam F spring

15.1 Remove both valve cam F springs from the selection guide for right and left end needles.

16. Removing the nut

16.1 Remove both nuts from the front side of carriage.

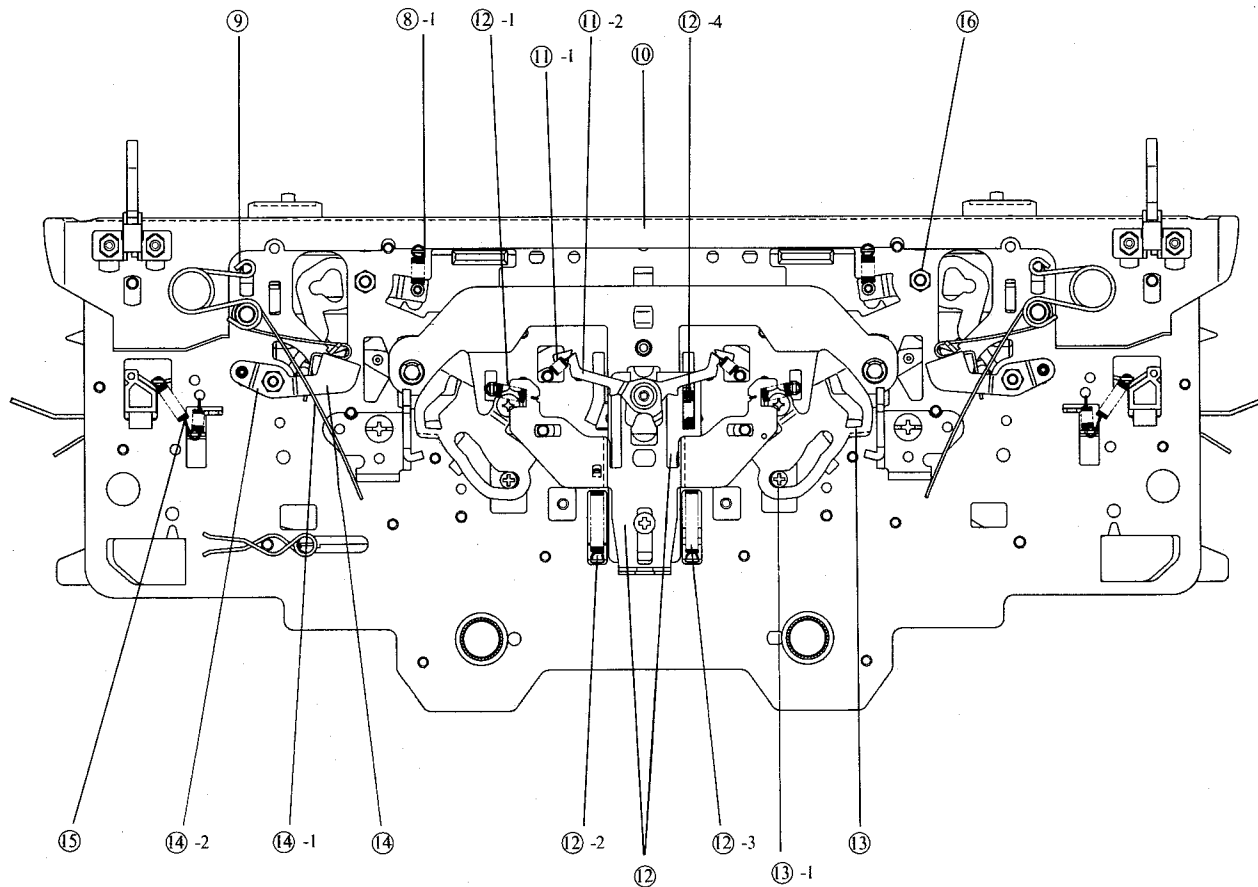

Names of Parts

- ⑧ -1 Needle selection change lever spring
- ⑨ Connecting plate spring
- ⑩ Rear plate
- ⑪ Tuck cam operating plate
- ⑪ -1
- ⑪ -2
- ⑫ Change plate A (upper)/
Change plate B (lower)
- ⑫ -2 Change plate spring
- ⑫ -3 Change plate A spring
- ⑫ -4 Change plate B spring
- ⑬ Push-up change plate
- ⑬ -1 Push-up change plate clamp screw & collar
- ⑭ Cam change plate
- ⑭ -1 Valve cam E spring
- ⑭ -2 Cam change plate
- ⑮ Valve cam F spring
- ⑯ Nut

(Fig. 3)

17. Removing the front slide plate

17.1 Remove the right and left screws to pull up and remove the front slide plate, then the holding cam springs come off the front side.
(Be sure to set the H.C.L. knob to H position when pulling up the plate.)

18. Removing the carriage front foot

18.1 Remove two screws to detach the carriage front foot.

19. Removing the guide cam A

19.1 Remove the right and left screws to detach the guide cam A, and the slide cam comes off.

20. Removing the slide guide cam assembly

20.1 Remove two nuts of the slide guide cam screw from the front side of carriage, then remove the slide guide cam assembly by loosening two clamp screws.

21. Removing the push-up cam

21.1 Remove the right and left screws, which clamp the push-up cam, from the front side of carriage.

21.2 Then the push-up cams and the push-up cam holder plates come off.
(At the same time, remove the push-up cam guide.)

22. Removing the MC guide cam

22.1 Remove both screws on right and left sides, then the MC guide cams, the MC guide change cams, and the shafts come off.

23. Removing the thread-lace change plate

23.1 Remove two screws of the fastening plate for thread-lace change plate.

23.2 Loosen two screws of the rear foot.

23.3 Pull up and remove the thread-lace change plate.

24. Removing the stitch cam

24.1 Remove the right and left snap rings of the stitch cam shafts from the front side of the carriage.

24.2 Remove both nuts of sub stitch cams from the front side of the carriage with a box driver.

24.3 Remove the screw of the stitch cam (left), then the sub stitch cam (left), the stitch cam (left), the valve cam D (left), the valve cam D spring (left), the sub stitch cam shaft (collar), and the screw itself come off.

24.4 Remove the right stitch cam in the same way.

25. Removing the valve cam A

25.1 Remove both right and left valve cam as by removing the screws on the each sides.

26. Removing the MC cam

26.1 Remove both right and left MC cams by removing the screws on the each sides.

27. Removing the stitch cam guide plate

27.1 Remove the snap rings and the washers from the shaft to detach the stitch cam guide plate.

28. Removing the guide cam F

28.1 Remove both right and left guide cam Fs by detaching their screws.

29. Removing the needle selection cam

29.1 Remove the guide cam Gs by detaching their screws with a small Phillips screwdriver.

29.2 Remove the screws of needle selection cam, then the needle selection cams, the needle selection cam guide plates, and the needle selection change cams come off.

29.3 And remove the needle selection change spacers (collars) and the valve cam Fs.

30. Removing the separation cam and the buffer for selected needle

30.1 Remove the screws to detach the separation cams and the buffers for selected needle on both right and left sides.

31. Removing the tuck cam

31.1 Remove the screws of tuck cam on both right and left sides, then the tuck cam plate, the right and left tuck cams, the tuck cam springs, and the tuck cam shafts come off.

32. Removing the carriage rear foot

32.1 Remove the selection guides for end needle from the front side of the carriage and remove the end needle selection springs from the carriage plate.

32.2 Remove six screws to detach the rear foot.

32.3 And the selection cams for end needle, the end needle selection cam springs, and the selection guides for end needle come off.

33. Removing the connecting plate

33.1 Remove both right and left connecting plates by pulling up the front foot side.

34. Removing the needle selection change plate

34.1 Remove the clamp screws of needle selection change plates.

34.2 Remove the shafts for needle selection change cam.

(See Parts Catalogue, part no. 154 on page 3.)

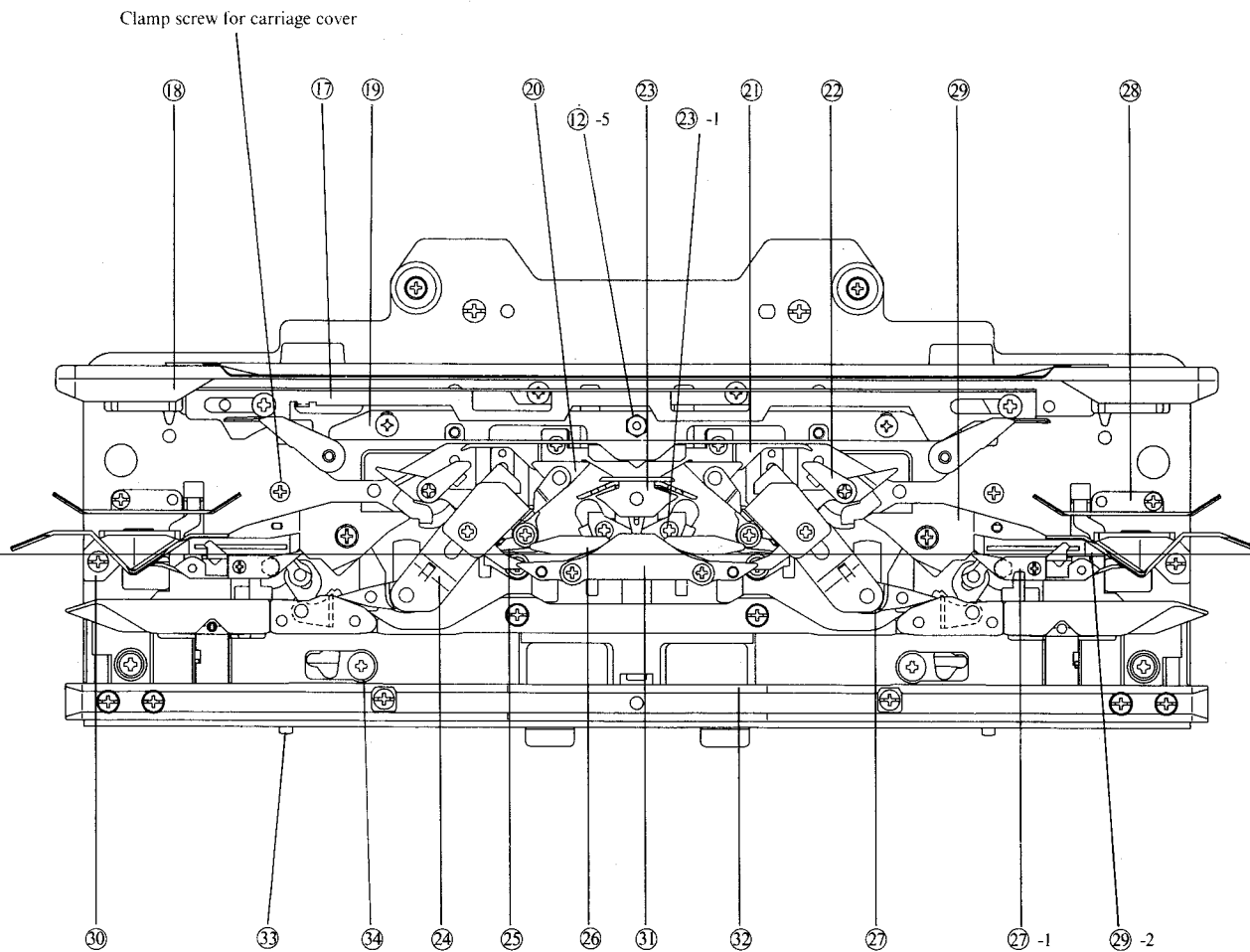

Names of Parts

- ①⑦ Front slide plate
- ①⑧ Front foot
- ①⑨ Guide cam A
- ②⑦ Slide guide cam
- ②① Push-up cam
- ②② MC guide cam
- ②③ Thread-lace change plate
- ②③ -1 Fastening plate for thread-lace change plate
- ②④ Stitch cam
- ②⑤ Valve cam A
- ②⑥ MC cam
- ②⑦ Washer
- ②⑧ Guide cam F
- ②⑨ Needle selection cam guide plate (upper)
- ②⑨ Needle selection cam (lower)
- ②⑨ -1 Guide cam G
- ②⑨ -2 Valve cam F
- ③⑦ Separation cam
- ③① Tuck cam
- ③② Rear foot
- ③③ Connecting plate
- ③④ Needle selection change plate clamp screw

(Fig. 4)

11.2 ASSEMBLING THE CARRIAGE

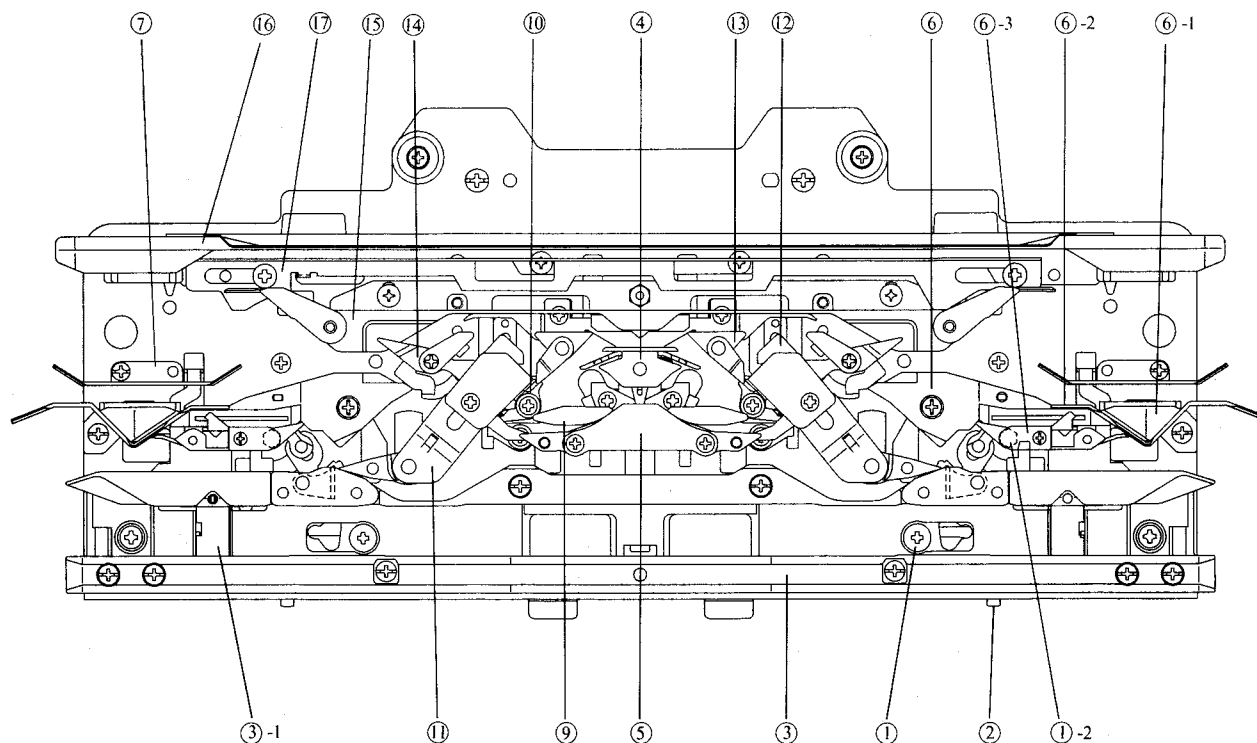

(Fig. 5)

Names of Parts

- ① Needle selection change plate
- ①-2 Shaft
- ② Connecting plate
- ③ Rear foot
- ③-1 Selection cam for end needle
- ④ Thread-lace change plate
- ⑤ Tuck cam
- ⑥ Needle selection cam (lower)
- ⑥-1 Needle selection cam guide plate (upper)
- ⑥-2 Buffer for selected needle
- ⑥-3 Separation cam
- ⑦ Guide cam G
- ⑧ Guide cam F
- ⑨ MC cam
- ⑩ Valve cam A
- ⑪ Stitch cam
- ⑫ Push-up cam
- ⑬ Slide guide cam
- ⑭ MC guide cam
- ⑮ Guide cam A
- ⑯ Front foot
- ⑰ Front slide plate

1. Mounting the needle selection change plate

- 1.1 Mount the needle selection change plates and clamp them with screws.
- 1.2 Mount the right and left shafts.

2. Mounting the connecting plate

- 2.1 Fit the connecting plates on the carriage plate.
(Take care not to confuse the right connecting plate with the left one.)

3. Mounting the rear foot

- 3.1 Mount both right and left selection guides for end needle onto the carriage plate. Clamp the rear foot with screws after putting the right

and left selection cams for end needle, end needle selection switch cams, and spring onto it.

- 3.2 Hook the end needle selection springs over the selection guides for end needle and the carriage plate.

4. Mounting the thread-lace change plate

- 4.1 Put the thread-lace change plate between the carriage plate and the rear foot.
- 4.2 Clamp the fastening plate for thread-lace change plate with screws.
(Be sure to check the thread-lace change plate moves smoothly.)

5. Mounting the tuck cam

5.1 Let the right and left screws through holes of the tuck cam plate and put the right and left tuck cams, shafts for tuck cams and the tuck cam spring; take care of the proper direction of the tuck cam spring. Then clamp the tuck cam assembly onto the carriage plate with screws.
(These tuck cams should be kept open, and should be returned to their home position by the spring pressure when they are pressed and released.)

6. Mounting the needle selection cam and the separation cam

6.1 Fit both buffers for selected needle into the square holes of the carriage plate.
6.2 Put each separation cam and needle selection cam together and mount each needle selection cam guide plate onto needle selection cams. Fix them respectively with screws.
6.3 Put the valve cam Fs, the needle selection change spacers (collars), the needle selection change cams, and the guide cam Gs in this order. Then assemble them with screws and a small Phillips screwdriver.

7. Mounting the guide cam F

7.1 Mount the left guide cam F and fix it with a screw.
7.2 Mount the right guide cam F in the same way.

8. Mounting the stitch cam guide plate

8.1 Mount the stitch cam guide plate from the front side of the carriage. Then put washers to the right and left shafts of the stitch cam guide plate from the bottom side of the carriage and fix them with snap rings.

9. Mounting the MC cam

9.1 Tighten the screws of MC cams.
(Be sure to check these MC cams move lightly.)

10. Mounting the valve cam A

10.1 Tighten the screws of valve cam As.
(The valve cam A should be moved lightly by the pressure of the valve cam D spring.)

11. Mounting the stitch cam

11.1 Mount the left sub stitch cam shaft (collar), valve cam D spring, valve cam D, stitch cam, and sub stitch cam in this order onto the carriage plate. Assemble them with a screw and fix them with a nut from the front side of the carriage.
(Be sure to set the valve cam D spring properly so that its straight end may be placed over the bent part of the valve cam D and its curved end over the valve cam A.)

11.2 Assemble and mount the right stitch cam in the same way.

11.3 Put the snap rings to the stitch cam shafts to fix them from the front side of the carriage.
(Be sure to check the valve cam D and the stitch cam moves lightly and the valve cam D is returned to its home position by the spring pressure.)

12. Mounting the push-up cam

12.1 Put the push-up cam holder plates to the sliding grooves of each push-up cam. Then mount the right and left push-up cams.
12.2 Put both push-up cam slide plates from the front side of the carriage and fix them with screws.
(Be sure to check the push-up cams move lightly.)

13. Mounting the slide guide cam

13.1 Mount the slide guide cam and fix it with two screws.
13.2 Tighten two nuts from the front side of the carriage.

14. Mounting the MC guide cam

14.1 Mount the shafts (collars), the MC guide change cams, the MC guide cams onto the carriage in this order and fix them with screws.
(Be sure to check the MC guide change cam moves lightly.)

15. Mounting the guide cam A

15.1 Mount the guide cam A and fix it with screws on its both sides while putting the slide cam into the floated part of the slide guide cam.
(Mounting dimension from rear foot is 71 mm: See How to Adjust the Carriage mentioned in this manual.)

16. Mounting the front foot

16.1 Tighten the two screws in the middle of the carriage front foot.

17. Mounting the front slide plate

17.1 Mount the front slide plate onto the front foot and fix them with both right and left stud screws of the front foot.
(Be sure to check the slide plate moves lightly and the change cams move down when the slide plate is slid to the H (Holding) position.)

18. Mounting the cam change plate

- 18.1 Mount and fix the cam change plate with nuts.
- 18.2 Hook the valve cam E springs over the carriage calking pin and the valve cam E.

19. Mounting the valve cam F spring

- 19.1 Hook the valve cam F spring over the selection guide for end needle and the valve cam F on each side.

20. Mounting the nut

- 20.1 Mount the nuts with box driver (6 m/m).

21. Mounting the push-up change plate

- 21.1 Put the screws of push-up cam slide plates and the shafts of MC guide cams into the holes of push-up change plates. Attach the collars and fix them with screws.

22. Mounting the change plate A and B

- 22.1 Mount the change plate B and the change plate A in this order. Then put the screw (change plate guide collar) and fix them with the nut (6 m/m).
- 22.2 Hook the change plate spring to the left.
- 22.3 Hook the change plate A spring to the right.
- 22.4 Attach the change plate B spring between the change plate B and the thread-lace change plate.

23. Mounting the tuck cam operating plate

- 23.1 Put the tuck cam operating plate right, first onto the shaft of the stitch dial then put the tuck cam operating plate left and the collar over them.
- 23.2 Hook both right and left tuck cam springs over the calking pins of the tuck cams.

24. Mounting the carriage rear plate

- 24.1 Mount the carriage rear plate and hook the change lever springs.

25. Mounting the connecting plate spring

- 25.1 Hook the right and left connecting plate springs over the calking pins of connecting plate and the shafts of change knob.

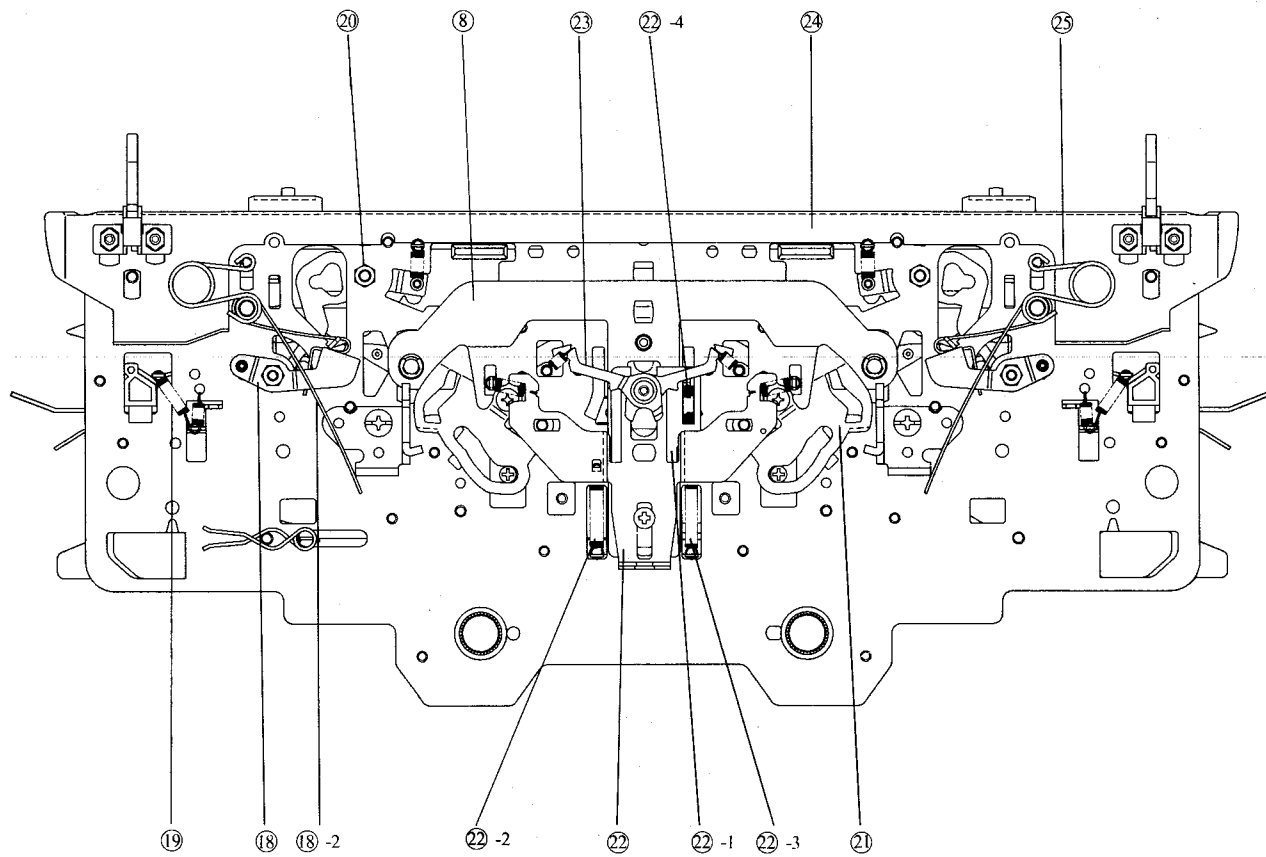

Names of Parts

- ⑧ Stitch cam guide plate
- ⑱ Cam change plate
- ⑱-2 Valve cam E spring
- ⑲ Valve cam F spring
- ⑳ Nut
- ㉑ Push-up change plate
- ㉒ Change plate A
- ㉒-1 Change plate B
- ㉒-2 Change plate spring
- ㉒-3 Change plate A spring
- ㉒-4 Change plate B spring
- ㉓ Tuck cam operating plate
- ㉔ Rear plate
- ㉕ Connecting plate spring

(Fig. 6)

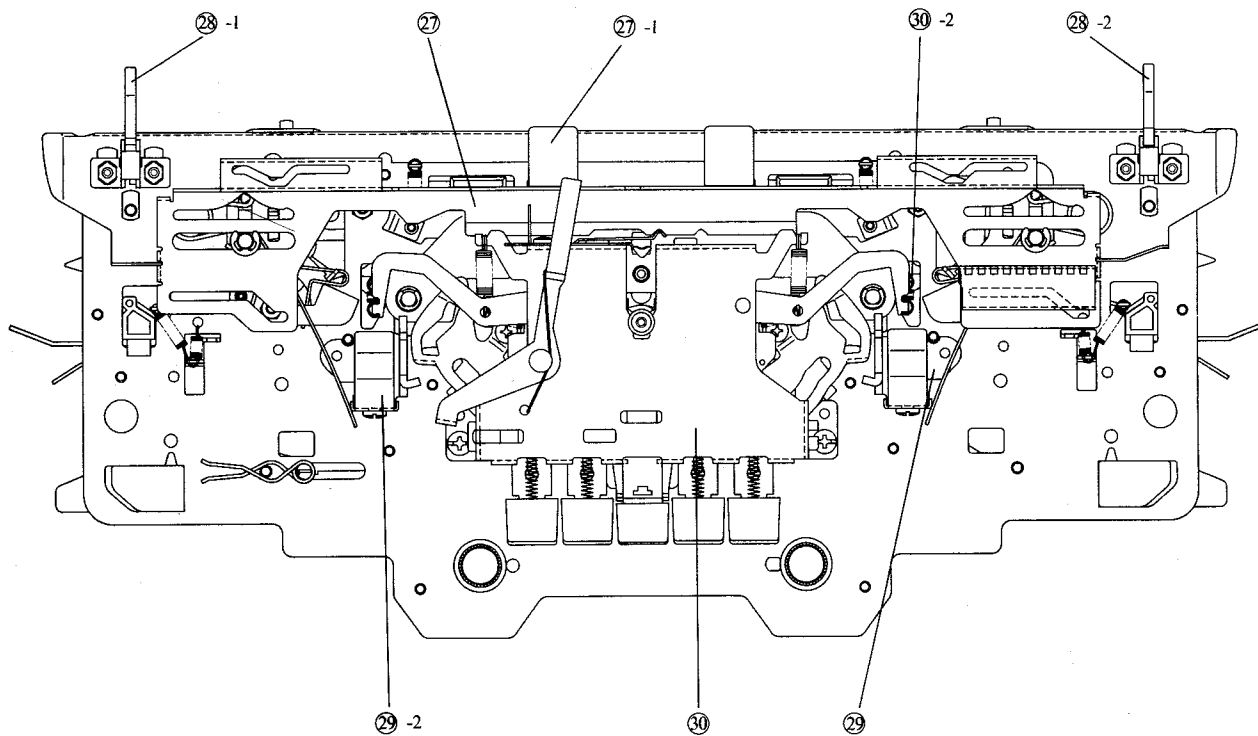

Names of Parts

- ②7 Upper slide plate
- ②7 -1 Magnet holder
- ②8 -1 Knit-leader tripper
- ②8 -2 Row counter tripper
- ②9 Handle setting base
- ②9 -2 Handle lock spring
- ③0 Cam button unit
- ③0 -2 Raising cam change spring

(Fig. 7)

27. Mounting the upper slide plate (Mounting the magnet holder)

- 27.1 Put the two magnet holders in the holes of the carriage plate.
- 27.2 Mount the upper slide plate so that the calking pins of the carriage plate, the connecting plate pins, and the cam change plate pins, on both right and left sides, come into six slots of the upper slide plate. (Be sure to check the pins of needle selection lever are located before the upper slide plate.)
- 27.3 Fix the upper slide plate with snap rings on both right and left carriage calking pins.

28. Mounting the knit-leader tripper and the row counter tripper

- 28.1 Put the knit-leader tripper on the left side and fix it with two screws from the carriage bottom.

- 28.2 Put the row counter tripper on the right side and fix it in the same way.

29. Mounting the handle setting base

- 29.1 Fix the handle setting bases with screws.
- 29.2 Fix the handle lock springs with screws.

30. Mounting the cam button unit

- 30.1 Fit the cam button unit to the shaft of stitch dial and fix it with screws on both sides.
- 30.2 Pull up the right and left raising cam change springs and hook them over the cam calking pins while pushing "Part" buttons, right and left. (Be sure to check the cams surely change when the buttons, TUCK (R/L), MC, L, PART (R/L), are pushed.)

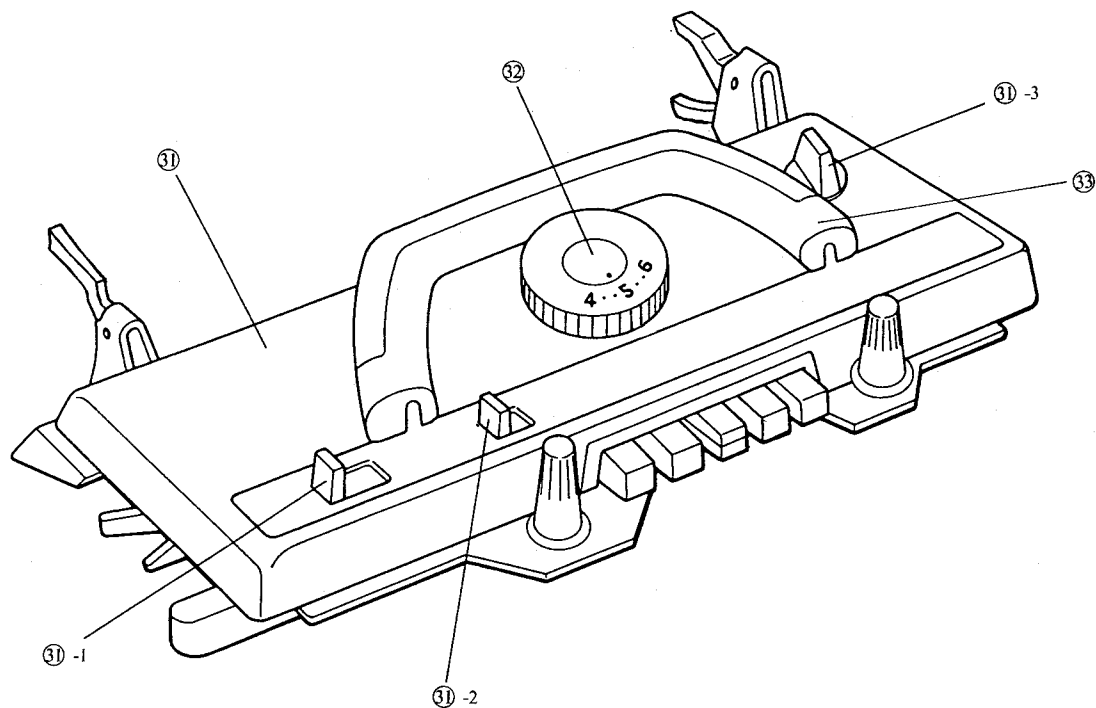

Names of Parts

- ③① Carriage cover
- ③① -1 H.C.L. knob
- ③① -2 Plain lever knob
- ③① -3 Change knob
- ③② Stitch dial cap
- ③③ Carriage handle

(Fig. 8)

31. Mounting the carriage cover

- 31.1 Put the H.C.L. spring to the shaft of H.C.L. knob and mount the H.C.L. knob over them.
- 31.2 Fit the plain lever knob to the cam button unit.
- 31.3 Mount the change knob onto the knob shaft.
Note: The mark should come right above the number on the stitch dial.
- 31.4 Mount the carriage cover and fix it with screws on the bottom.

32. Mounting the stitch dial

- 32.1 Mount the stitch dial onto the shaft. Fix it with the screw while keeping the cut of stitch dial presser just forward.
- 32.2 Then mount the stitch dial cap onto them while aligning its pointer mark to the cut of stitch dial presser.
***Be sure to check the pointer mark comes right in front of any figure on the stitch dial.**

33. Mounting the carriage handle

- 33.1 Fix the handle with pin screws while keeping it down.

11.3 CHECKING THE CARRIAGE FUNCTIONS — 1 —

1. Change knob function	1.1 When the change knob is switched to each position, it should move smoothly; the right or left part of the connecting plate and the needle selection switching cam should work without fail.
2. MC cam operating	2.1 When the end of the right or left part of the MC cam is pressed fully down and then quietly lifted with your finger while keeping the MC button depressed all the time, the right and left parts of the MC cam should return to their original position under spring pressure.
3. MC knitting change cam operation	3.1 The right and left parts of the MC cam should shift without fail while the MC button is kept depressed.
4. Raising cam operation	4.1 When the end of the right or left part of the raising cam is lifted fully with the stitch dial at the 0,5, or 10 position and quietly lowered with your finger, the right or left part of the raising cam should return to its original position without fail under spring pressure.
5. Needle selection cam operation	5.1 When the needle selection cam is set at "KC" and when the end of the right or left part of the needle selection cam is fully lifted and then quietly lowered with your finger, the cam should return to its original position without fail under spring pressure.
6. Tuck cam operation	<p>6.1 When the right or left part of the cam button is depressed, and when the end of the right or left part of the cam is fully lifted and then quietly lowered with your finger, the right or left part of the tuck cam should return to its original position without fail under spring pressure.</p> <p>6.2 When the cam button is set at plain, and when the end of the right or left part of the tuck cam should return to its original position without fail under spring pressure.</p>
7. Cam button unit function	7.1 When the cam button is shifted to "TUCK right and left," "MC", "L" or "PART right and left," the button should move smoothly and the tuck cam, the MC cam, the raising cam, push-up cam, thread-lace change plate and MC guide cams should shift their places without fail.
8. Holding cam lever function	8.1 When the holding cam lever is shifted to "H" or "N", it should move smoothly and the holding cam should make accurate operation without fail.
9. Plain knitting lever function	9.1 When the plain knitting lever is thrown rightward while pressing "TUCK right and left," "MC", "L", or "PART right and left" buttons, the lever should move smoothly and the cam button should return to its original position without fail.

11.4 CHECKING THE CARRIAGE FUNCTIONS — 2 —

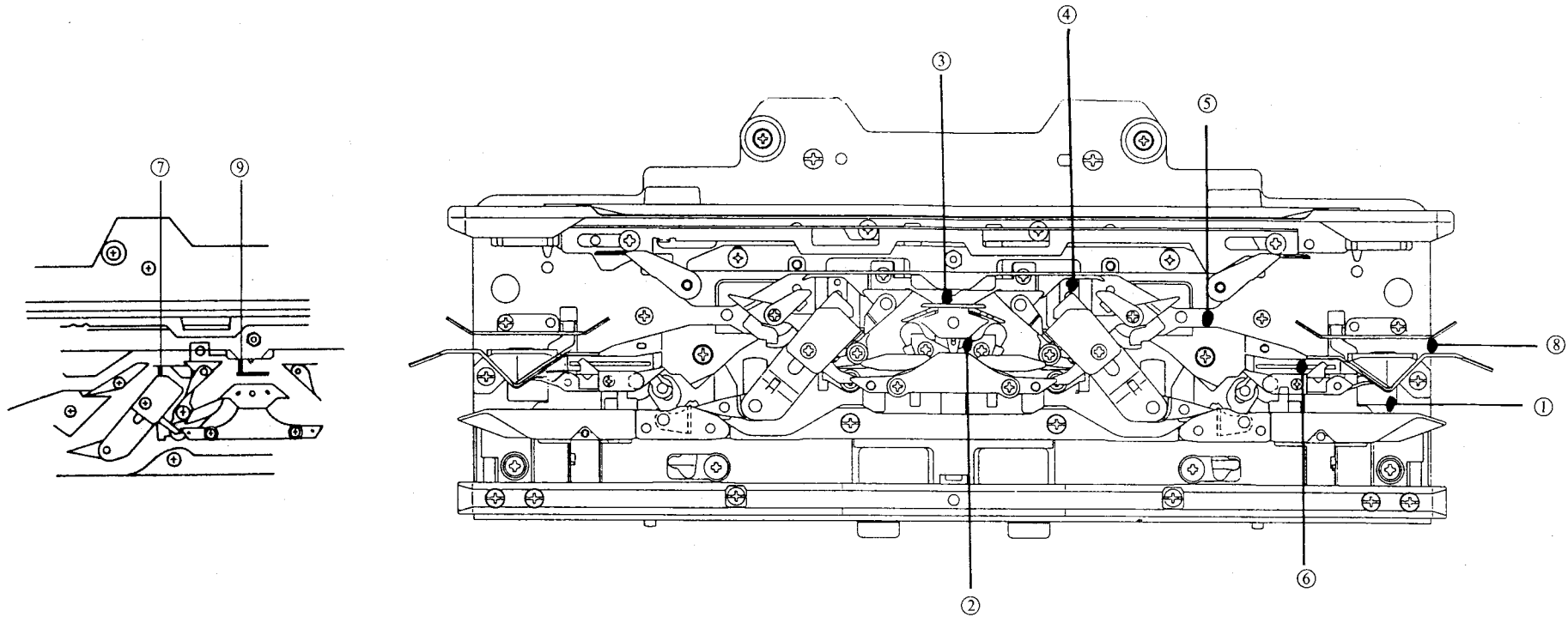

(Fig. 9)

<Check to be sure needle butts smoothly pass the following>

- ① Between the rear foot and the separation cam
- ② Between the tuck cam plate and the thread-lace change plate
- ③ Between the slide guide cam and the slide cam
- ④ Between the push-up cams
- ⑤ Between the needle selection cam and the guide cam A
- ⑥ Between the needle selection cam and the guide cam G

- ⑦ Between the push-up cam and the guide cam A
(when the "L" button is pushed)
- ⑧ Between the guide cam F and the separation cam
- ⑨ Between the slide guide cam and the thread-lace change plate
(when the "L" button is pushed)

11.5 HOW TO ADJUST THE CARRIAGE

1. The carriage does not move smoothly. The fabric floats (stitch float)

Cause

1. The sinker plates are in contact with the gate pegs.
There is too much gap between the sinker plates and the gate pegs.

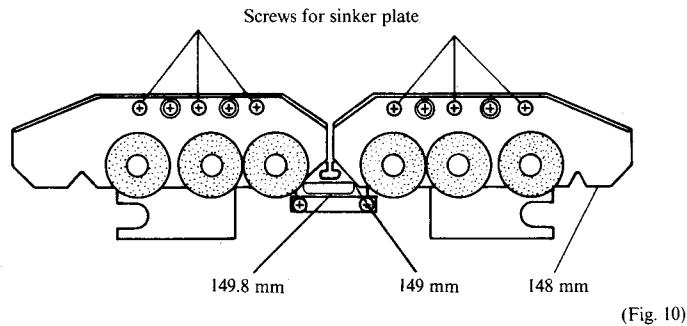

2. The sinker plates keep up the plain needles.
There is too much gap between the sinker plates and the plain needles.

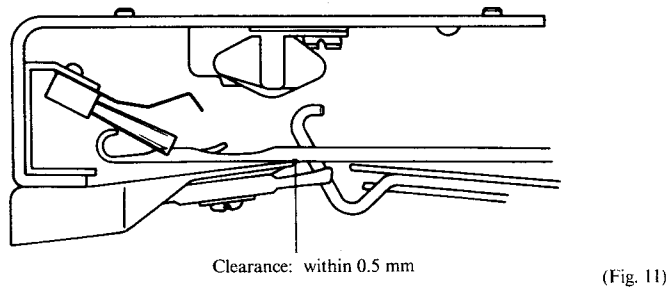

Adjustment

<Longitudinal adjustment of sinker plate>

1. The carriage plate and the sinker plates of this model KH-270 are processed already properly; therefore there is no need to readjust them.
2. Mounting dimension of sinker plate
The standard dimensions between the carriage rear rail and the sinker plate are 149 mm on the inside and 148 mm on the outside. When necessary, loosen six screws of sinker plates on both sides for proper adjustment. (See Fig. 10.)

<Mounting dimension of yarn feeder>

1. Mount the yarn feeder so that the dimension to the carriage rear rail may be 149.8 mm.

<Vertical adjustment of sinker plate>

1. Fit the carriage to the needle bed and set the H.C.L. knob to the position H.
2. Put some five plain needles forward to the point E on three positions, right, middle and left of the needle bed.
3. Bend and adjust the sinker plates so that the clearance between the stems of plain needle and the sinker plates may not exceed 0.5 mm.

2. The carriage stops midway. The latches of plain needle become bent.

Cause

1. The guide cam A is installed wrongly.

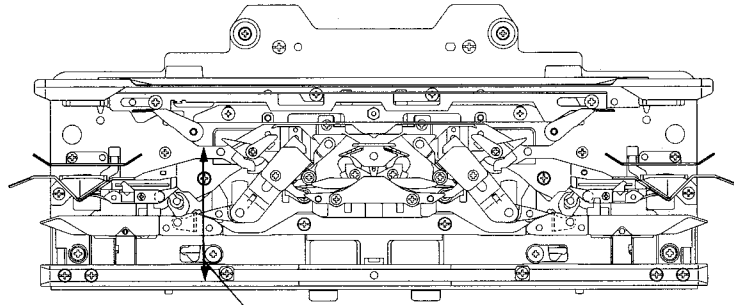

71 mm (±0.3 mm)

(Fig. 12)

Adjustment

<Mounting dimension of guide cam A>

1. Loosen the right and left screws of guide cam A and the nut of change plate. Then clamp again after adjusting the distance from the rear foot may become 71 mm.
*1. If the mounting dimension between the guide cam A and the rear foot should not reach 71 mm, the plain needles cannot pass there; narrow clearance between the guide cam A and the needle selection cam.

3. The end needle selection cannot be performed.

Cause

1. Fault of selection cam for end needle
- Heavy operation
Wear

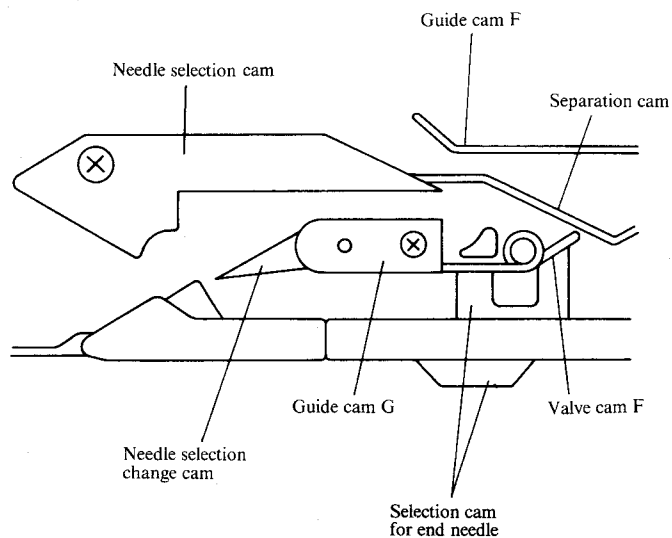

(Fig. 13)

Adjustment

1. Replace the selection cam for end needle
 - ① Remove the carriage cover.
 - ② Remove the springs of valve cam F and the end needle selection springs.
 - ③ Set the change knob to the "N" position and push the button "PART right and left". Then remove the guide cam Gs, the needle selection change cams, the needle selection change spacers (collars), and the valve cam Fs.
 - ④ Remove the needle selection cams, the separation cams, and the guide cam Fs.
 - ⑤ Loosen and remove six screws to detach the rear foot from the carriage plate.
 - ⑥ Then the selection guides for end needle and the selection cams for end needle come off.

11.6 MOUNTING DIMENSIONS OF EACH CARRIAGE CAM

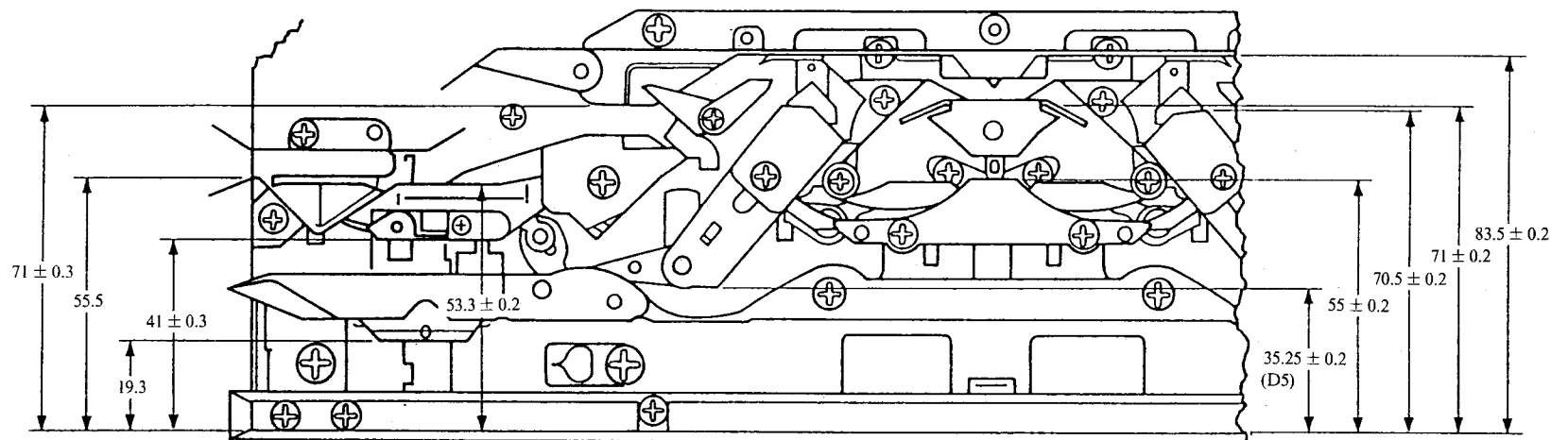

(Unit: mm)

(Fig. 14)

12. DISASSEMBLY AND ASSEMBLY OF THE MAIN BODY

12.1 Disassembling the Main Body

1. Removing the panel

* Removal sequence: first, the pattern case whole unit is removed, and then the accessory box assembly.

1.1 Removing the pattern case whole unit

Remove the two screws, and then, while lifting the left side of the panel, slide it to the left and remove it from the right of the lower side plate, turning it over and then upside down toward the rear of the main body.

* There are five connectors joined to the main PC board and the control board on the rear of the pattern case whole unit which make it difficult to raise the operation panel. Be sure to exercise sufficient caution when raising the pattern case whole unit so as not to damage these connectors.

1.2 Disconnect the five connectors from the main PC board and the control board at the rear of the pattern case whole unit.

2. Removing the accessory box assembly

2.1 Remove the two screws (one of them is inside the accessory box), then, while raising the right side of the assembly, slide it toward the right and remove it from the left of the lower side plate.

3. Removing the main body

3.1 Remove the three screws from the carrying case reinforcing plate.

3.2 Remove the two screws from the yarn tension stand.

3.3 Remove two screws each from both the left and right of the needle bed.

3.4 Remove one screw from both the left and right of the front needle bed.

3.5 Remove two main body screws each from both the left and right of the rear of the main body, and then remove the table clamp setting plate.

3.6 Raise the right side of the needle bed gently and slide it toward the right, removing it from the bottom of the case.

4. Removing the left position sensor PC board and the right position sensor PC board

4.1 Take the screws from each of the PC boards and remove them.

5. Removing the cord cover

5.1 Remove the two screws from the cord cover and remove the cord cover.

6. Removing the belt

6.1 Loosen the pulley adjusting plate screws (Ref. No. C-42) on the pulley holder plate on the left side of the main body.

6.2 Turn the pulley to move the belt joint before you to the center of the main body.

6.3 Remove the belt screws from the hole and remove the belt.

7. Removing the needle selector unit (with needle selector plate holder)

<Check the distance between the needle selector plate holder and the front needle bed>

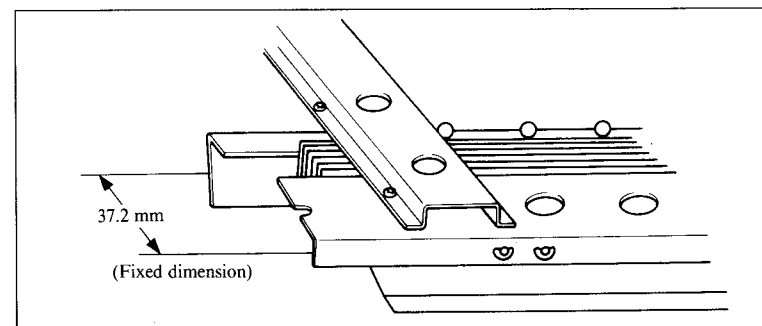

Figure 12-1

Take the measurements given the figure above and write them down, following the same measurements again during reassembly.

Note:

1. Do not remove the 5 screws on the needle selector plate holder and the 5 screws on the needle selector unit unless the needle selector unit is being disassembled.
2. When adjusting the mounting measurements of the gate peg, the stay need not be removed.
3. In the repair of the main body rotary cam lever and N.S.P. operation levers, the source of the problem may be discovered by removing the needle selector solenoid, the rotary cam lever holder, and the cam lever spring presser plate.
- 7.1 When the lower holder plate, yarn tension stand and the 16 screws with washers on the two gate peg right and center stays are removed, the needle selector unit and needle selector plate holder will come off as a single assembled unit.

8. Removing the needle selector plate holder from the needle selector unit

8.1 When three needle selector plate holder screws are removed, one from the center stay and two from the right stay, the needle selector unit comes off the needle selector plate holder. The 12 N.S.P. operation levers in the needle selector plate holder and the needle selector unit also come out.

9. Removing the needle selector plate holder

9.1 Remove the center stay, the two operation lever presser screws, and the operation lever presser.

9.2 Remove the six needle selector plate springs. (Make sure of the mounting direction and position of the springs before removing them.)

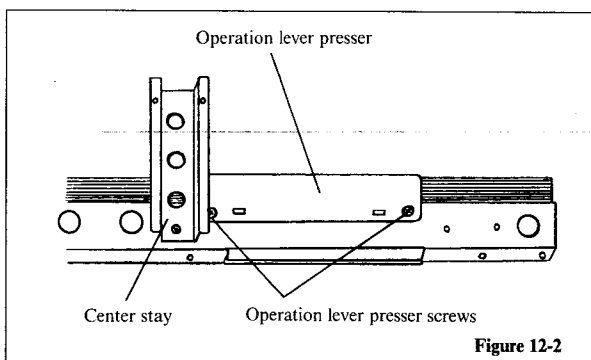

Figure 12-2

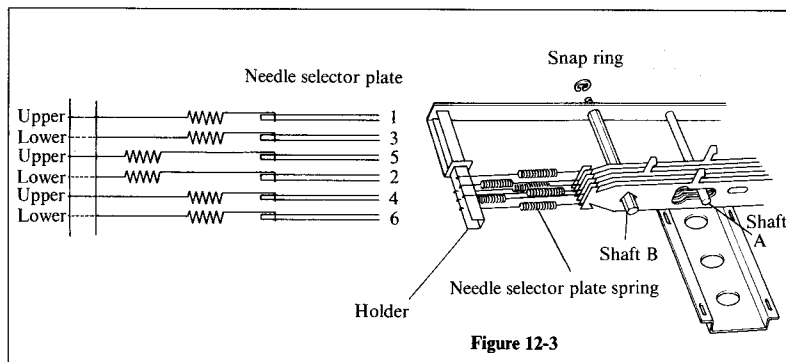

Figure 12-3

9.3 Remove the needle selector plate shaft B (angled) snap ring 2.5 from the rear side of the needle selector plate holder and pull the needle selector plate shaft out toward you.

9.4 Sliding each of the 6 needle selector plates toward the right, one by one, take them off the 7 grooves on shaft A.

10. Disassembly of the needle selector unit

10.1 Remove the 2 screws from the encoder PC board and remove the encoder PC board.

10.2 Removing the needle selection solenoid unit.

When the two screws are removed, the needle selection solenoid unit will come off.

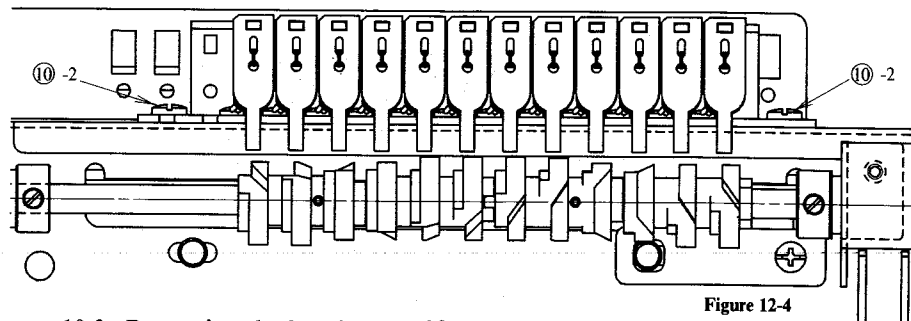

Figure 12-4

10.3 Removing the bevel gear Z32

(1) Remove the position sensor board holder plate R after removing the two screws and washers.

(2) Take the snap ring and washer from the pulley shaft R and remove the bevel gear Z32.

Note:

The washer on the rear of the bevel gear Z32 has grease on it so be cautious that it is not lost when it comes off.

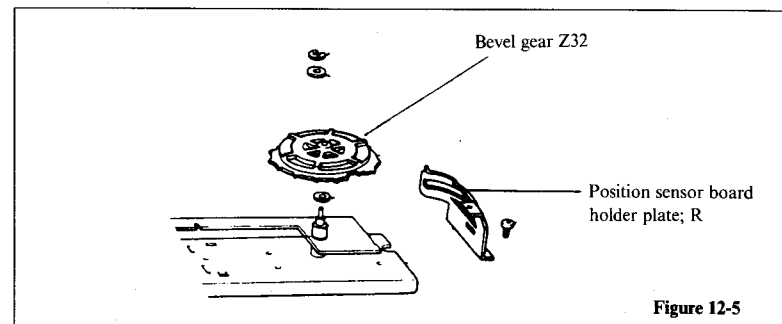
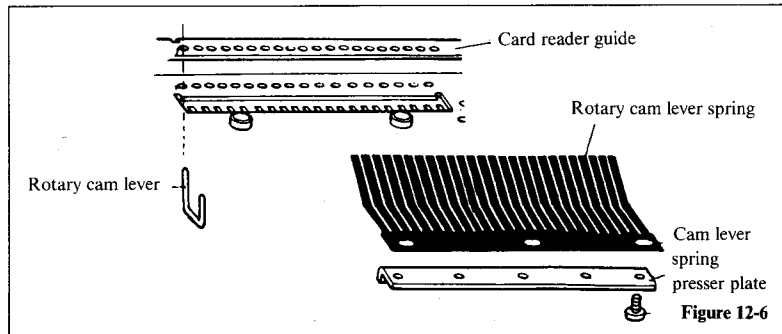

Figure 12-5

10.5 Removing the rotary cam lever

- (1) When the five cam lever spring presser plate screws are taken off, the cam lever spring presser plate and rotary cam lever spring come off and the 12 rotary cam lever may be taken out.



10.6 Removing the rotary cam

- (1) Take out the bevel gear spring pin and the slit disc spring pin.
- (2) Loosen the right and left rotary cam adjuster collar screws.
- (3) Take out the rotary cam holder (left) screws and then the rotary cam holder.
- (4) When the rotary cam is pulled toward the left and out of the rotary cam holder (right), the bevel gear and spacer will come out.
- (5) Take out the slit disc.

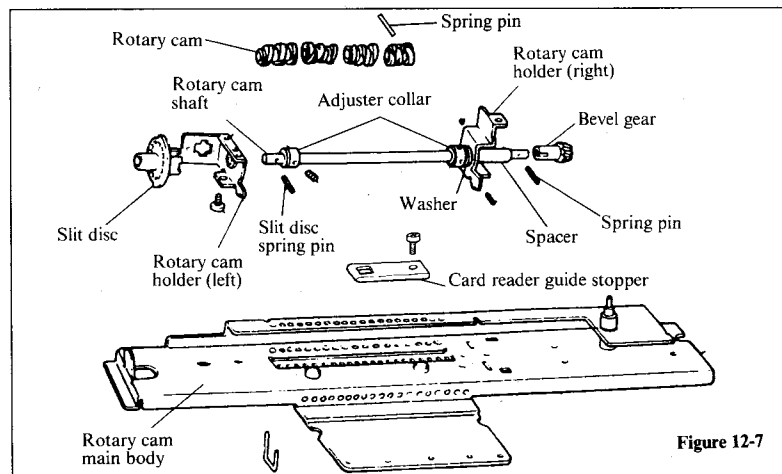

- (6) Take out the four rotary cam spring pins and pull out four rotary cams from rotary cam shaft.

12.2 Assembling the Main Body

1. Mounting the needle selector unit

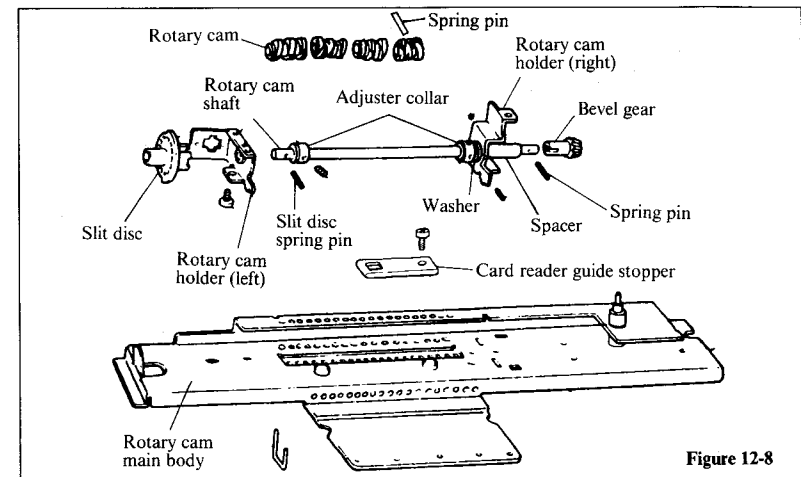

1.1 Mounting the rotary cam

- (1) Insert the rotary cam into the rotary cam shaft one by one, then join the hollow of the rotary cam to the projection of another rotary cam as shown in Figure 12-9.
- (2) Place the adjuster collars onto both ends of the rotary cam assembly.
- (3) Place the washers onto the side of the rotary cam assembly with the bevel gear spring pin hole, pass it over the rotary cam holder (right), place the spacer on, knock the bevel gear spring pin into its hole, and put the bevel gear on.

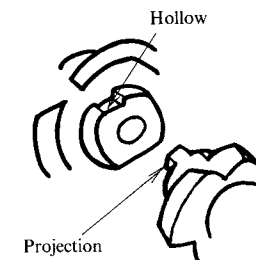

- (4) Insert the rotary cam holder (left) onto the other side of the rotary cam and insert the slit disc and install it to the main body.
- (5) Knock the slit disc spring pin into place.
- (6) Lightly oil the resin part of the rotary cam, the metal part of the bearing of the rotary cam holder right and left, and the teeth of the bevel gear with a soap based grease (Epinoch #1).

1.2 Mounting the rotary cam lever

- (1) Apply grease (Epinoch #1) to the card reader guide stopper hole on the rotary cam main body.
- (2) Insert the long side of the rotary cam lever into the guide hole of the main body, and insert the short side into the guide hole on the rotary cam lever.

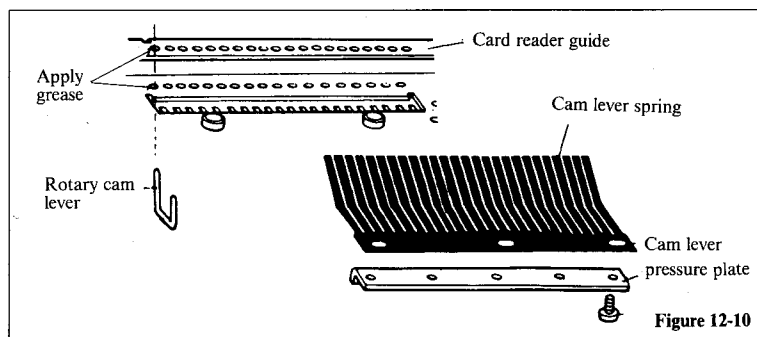

- (3) Apply grease to parts which come in contact with the rotary cam lever and cam lever spring and install the cam lever spring and the cam lever spring pressure plate. Install the cam lever spring pressure plate such that the side with the bend is toward the rotary cam lever.

1.3 Mounting the bevel gear Z32

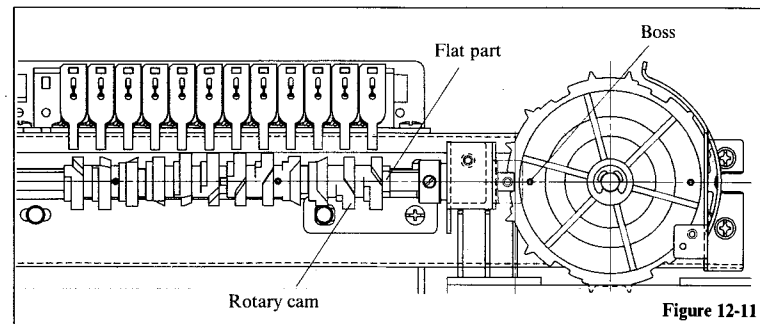

- (1) Turn the rotary cam until the flat part of the rotary cam's right end is horizontal, as shown in the figure (12-11).
- (2) Put the washer on the bevel gear Z32 and place the bevel gear Z32 such that its relationship to the rotary cam is as shown in Figure 12-11.
- (3) Put the washer on and secure it with a snap ring.
- (4) Mount the position sensor board holder plate R.

Note:

Apply grease (Epinoch #1) to the teeth of both the bevel gear and bevel gear Z32.

1.4 Mounting the needle selector unit

- (1) Place the needle selection solenoid armature on the tip of the rotary cam lever and install the two installation screws.

2. Mounting the needle selector plate holder

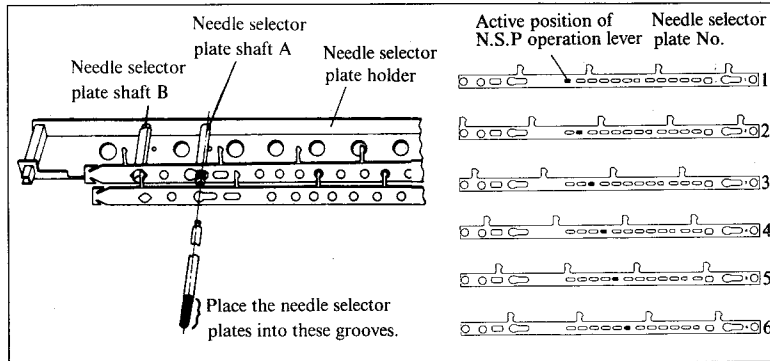

Figure 12-12

2.1 The needle selector plate holder should be mounted in the following sequence.

(1) Fit needle selector plate number 1 into the seven grooves in needle selector plate shaft A of the needle selector plate holder, and, sliding it toward the left, push it in (refer to figures 12-12).

* The grooves in needle selector plate shaft A go, from the needle selector plate holder side, in the following sequence; 1, 3, 5, 2, 4 and 6. Exercise sufficient caution in this regard when pushing the needle selector plates into the needle selector plate holder.

* Also be cautious to ensure that the plates are not bent so far that they break when being inserted.

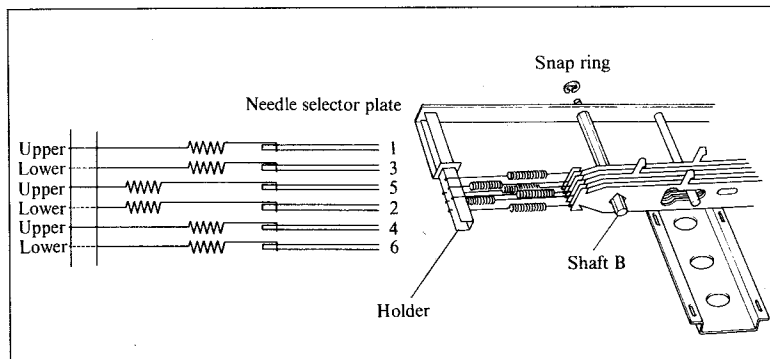

Figure 12-13

(2) Next hook the needle selector plate spring onto needle selector plate 1 and the needle selector plate holder spring hook.

* The needle selector plate spring should be hooked as follows: 3, 2, and 6, from the needle selector plate holder side, should be hooked to the spring hook on the lower side of the needle selector plate. The remaining plates, 1, 5 and 4 should be hooked on the spring hook on the upper side of the needle selector plate.

* The springs should be hooked alternately to the top and bottom of the plates.

(3) Next place needle selector plate 3 to the needle selector plate holder in the sequence given in (1) and (2) above. Similarly, place the remaining needle selector plates, 5, 2, 4 and 6 to the needle selector plate holder, in that sequence (refer to figure 12-13).

(4) After placing the needle selector plates, insert needle selector plate shaft B (angled) and secure it with a snap ring 2.5 (refer to figure 12-13).

3. Mounting the needle selector unit and the needle selector plate holder to the main body

3.1 Mount the needle selector plate holder and the needle selector unit to the center and right stays. The mounting holes in the center and right needle selector plate holder stays and in the needle selector unit are oblong horizontal holes, so use the center of the hole and tighten only lightly.

3.2 Put the 12 N.S.P. operation levers through the holes in the needle selector plate and into the left side of the rotary cam lever and mount the N.S.P. operation lever presser.

4. Mounting the needle selector unit and the needle selector plate holder to the main body

4.1 Place the needle selector plate shaft B of the needle selector plate holder into the angled hole in the main body.

4.2 Put one screw into each of the oblong, vertical holders in the main body for the installation of the center and right stays, tightening it only lightly.

4.3 Adjust the center of the bevel gear Z32 so that it has the same relationship as in the above figure 12-14 and tighten the center and right stays.

4.4 Install the table clamp setting plate, and yarn take-up stand in such a way that the main body and the needle selector plate holder will be set in parallel with each other.

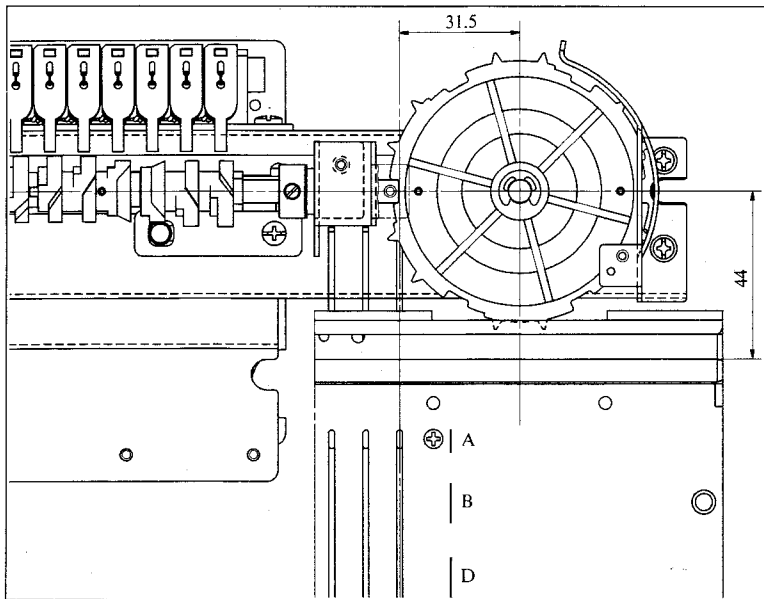

Figure 12-14

5. Mounting the belt

- 5.1 Take the belt connecting pin such that it is on the inside and place it, fitting onto the bevel gear Z32 as shown in the figure 12-15.
- 5.2 Turn the bevel gear Z32 pulley by the rib and pull out the rear rail side.
- 5.3 On the left side, similarly, place the belt so that the long hole in it is matched to the notch in the pulley and pull out to the rear rail side. (in two cases out of six)
- 5.4 Pull both ends of the belt together so that the connector pins link with the joint hole in the other.
- 5.5 Adjust the pulley adjusting plate. (Ref. No. C-46) With the pulley pushed toward the right, adjust it so that it can move 0.3 to 0.6 mm and tighten the screws.

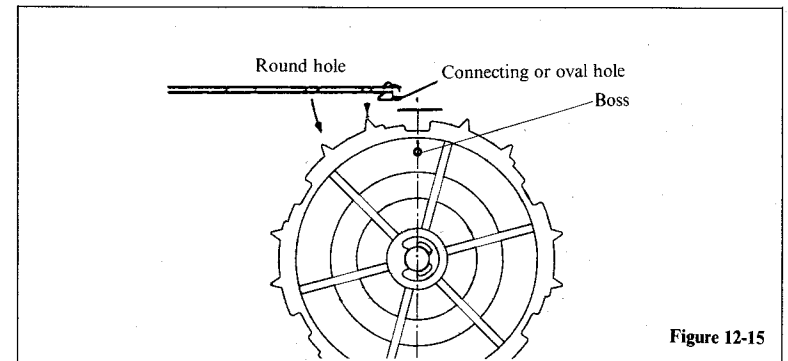

Figure 12-15

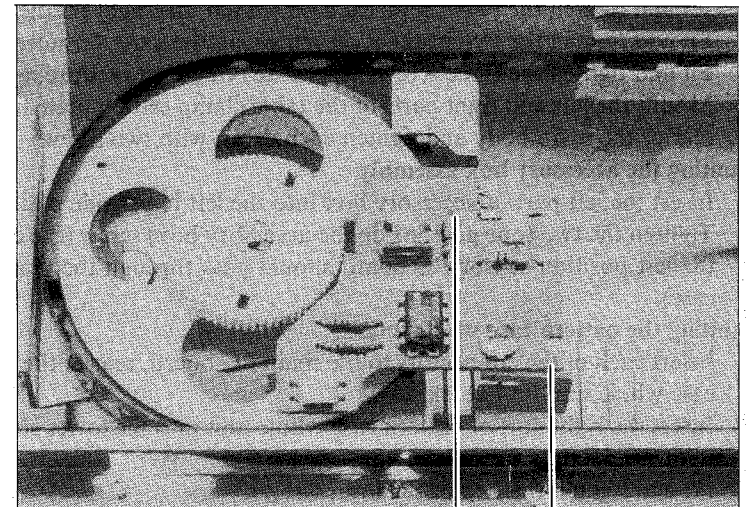

Figure 12-16

VR Left position sensor board

6. Mounting the encoder PC board

- 6.1 Fit the encoder PC board to the encoder board holder plate, rotary cam holder L and tighten it up with the two screws.
- 6.2 Place the board cord cover and secure it with two screws.

7. Mounting the left position sensor PC board and the right position sensor PC board

- 7.1 Tighten each of the PC boards down with screws.

8. The main body housing

- 8.1 Place the needle selector plate holder on the left side of the main body over the left lower side plate and put the main body under the case.
- 8.2 Fit and tighten the screw each on the left and right front portions of needle bed.
- 8.3 Fit and tighten the two screws each on the left and right needle beds.
- 8.4 Fit and tighten the two installation screws on the yarn tension stand.
- 8.5 Fit and tighten the three screws on the carrying case reinforcing plate.
- 8.6 Mount the left and right parts of the table clamp setting plate from the rear of the main body and tighten each down with two screws.

9. Mounting the accessory box assembly

- 9.1 Insert the left part of accessory box into the left lower side plate.
- 9.2 Tighten the two (one goes inside the accessory box) screw (the cord for the left position sensor PC board should pass through the rear of the case).

10. Mounting the pattern case whole unit

- 10.1 Insert each of the connectors to the main PC board, rear of the pattern case whole unit (in five places).
- 10.2 Insert the right part of pattern case whole unit into the lower side plate right.
- 10.3 Fit and tighten the two installation screws.

12.3 How to adjust the needle bed comb (Ref. No. B-4, 5, 6 In Parts catalogue)

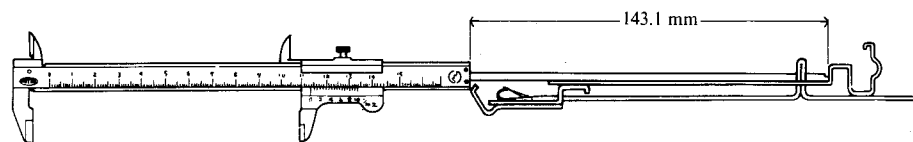

Figure 12-17

1. Take out the machine body from the lower case assembly (See p. 35).
2. Loosen 9 clamping screw for needle bed comb on stay right, center, and lower holder plate.
3. Loosen 12 clamping nuts on the back side of combs with a wrench.
4. Put out three needles each at both ends and in the central part of the needle bed and determine a position of combs so as to let needles come to midway between both combs. (Bilateral adjustment)
5. Set fitting measurement of combs at 143.1 m/m at both ends and in the central part of the machine body and fasten with clamping nuts. (longitudinal adjustment)

* Note

In this case, keep it in mind that if such nuts are tightened too hard, screw will be twisted off.

Adjust measurement of fitting combs by use of a sliding calipers and fasten with clamping nuts (refer to Fig. 12-17).

13. ADJUSTMENT AND CHECK OF THE NEEDLE SELECTOR MECHANISM

13.1 Adjusting the Card Reader Guide Plate

- (1) Remove the pattern case whole unit and the remove the cord cover. The pattern case whole unit should be placed, with connectors still joined, to the rear of the main body.
- (2) Connect the AC adapter.
- (3) Turn the switch on and the MEMO key on.
- (4) Align all of the knitting needles to position A, set the K carriage change knob to KC. When the K carriage is operated, needle selector solenoids are all energized to be attracted.
- (5) Loosen the screws on the card reader guide stopper. Then, after sliding the card reader guide stopper over to the right, slide it very lightly back to the left, and tighten the screws such that the right window of the card reader guide plate lightly touches the contact.

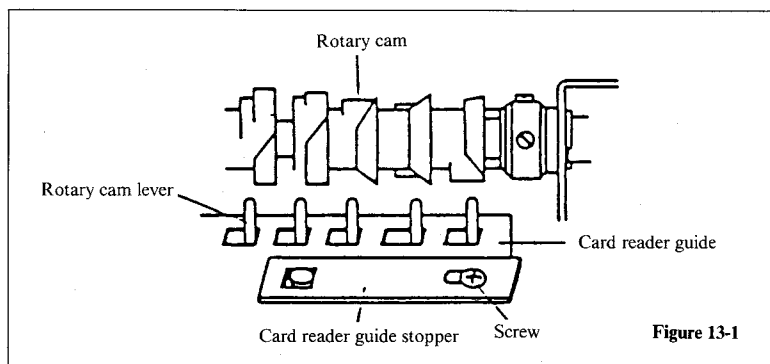

Figure 13-1

13.2 Adjusting the Rotary Cam Position

- (1) Turn the switch on and the MEMO key on.
- (2) Align all of the knitting needles to position A, set the K carriage knob to KC. When the K carriage is operated, needle selector solenoids are all energized to be attracted.
- (3) After the completion of the card reader guide plate adjustment, loosen the four stop screws on the rotary cam adjuster collar and the rotary cam presser collar.
- (4) With a feeler gauge make a 0.5 ~ 0.8 mm (TYP 0.7 mm) gap between the rotary cam and the rotary cam lever. Then, holding the rotary cam to the right with a flat head screw driver, tighten the screw (if no feeler gauge is available, approximate the distance visually.)

- (5) Make a 0.2 mm gap between the rotary cam presser collar and the left rotary cam holder and tighten the screws. Tighten the four screws each twice to make sure that they are tight.
- (6) Place all the knitting needles at position B.
- (7) Turn the power switch off, turn the K carriage change knob to <KC> and check all needles are selected to position D when the carriage is moved slowly and when it is moved quickly.

* The movement of the K carriage is unusually sluggish when there is no gap in the rotary cam pressure collar or when the gap in the rotary cam adjuster collar is too great.

* When there are needles which do not come out to position D, make the gap in the rotary cam adjuster collar greater.

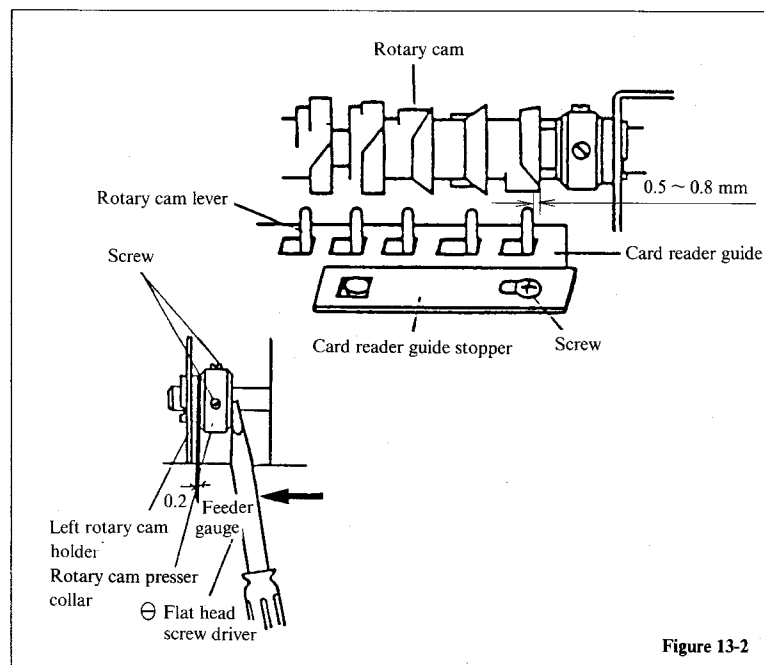

Figure 13-2

13.3 Checking the Needle Selector Mechanism

1. The objectives of check sequence 1

First of all, in order to determine whether the cause of the error in needle selection is in the needle selection mechanism (the mechanism portion), or in the electronic portions, move the carriage with the power turned off.

When the power is turned off, the solenoids are also all off, all of the rotary cam levers are on the rotary cams, and the knitting needles should all be selected to position D.

With this test, the carriage needle selection mechanism, the rubbing surfaces of the needle selection solenoid armature, the rotary cam, the rotary cam levers, the N.S.P. operation levers, and the needle selector plate may be checked.

2. When the test determines that not all of the needles come out to position D, but that some remain in position B.

- (1) When there is no regularity (e.g., 6 pitches, 12 pitches, etc.) in the needles remaining in position B
 - a. The knitting needles are bent.
 - b. The belt has not been properly mounted to the bevel gear Z32 assembly.
 - c. The rotary cam has not been properly mounted to the rotary encoder.
 - d. The card reader guide plate or the bevel gear Z32 assembly position are out of adjustment.
- (2) When the needles remaining the position B show regularity (6 pitches or $6 \times n$ pitches)
 - a. The needle selector plate is not moving because the rotary cam levers and N.S.P. operation levers have not been mounted properly.
 - b. The rotary cam lever is getting caught on the card reader guide and, slipping, do not move. Apply grease.
 - c. The needle selector solenoid armature and the solenoid yoke are getting caught, and, slipping, do not move.
 - d. The armature spring of the needle selector solenoid is bent or has come loose.

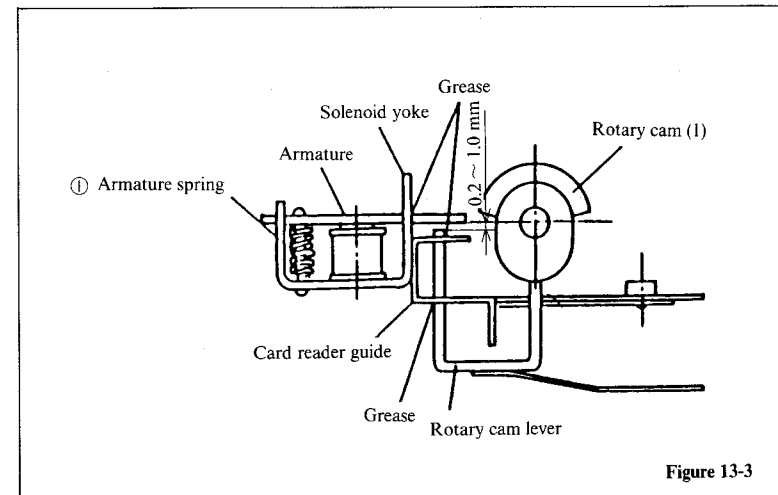

Figure 13-3

- c. The N.S.P. operation lever stay is interfering with needle selector plate number 6.
- f. The needle selector plate springs are loose or are interfering with one another.

3. When carriage operation is much heavy

- a. The carriage will not move
The carriage will not move when the rotary cam lever has come loose from the face of the rotary cam. When too much pressure is applied to the rotary cam lever, it will bend. After checking to ensure that the rotary cam lever has not become bent, adjust the positions of the card reader guide plate and the rotary cam.
- b. Carriage operation is not smooth
The rotary cam presser collar is making contact with the metal portion of the left rotary cam holder bearing. The gap between the rotary cam and the rotary cam adjuster collar is too wide.



