

Instruction manual for knitting machine

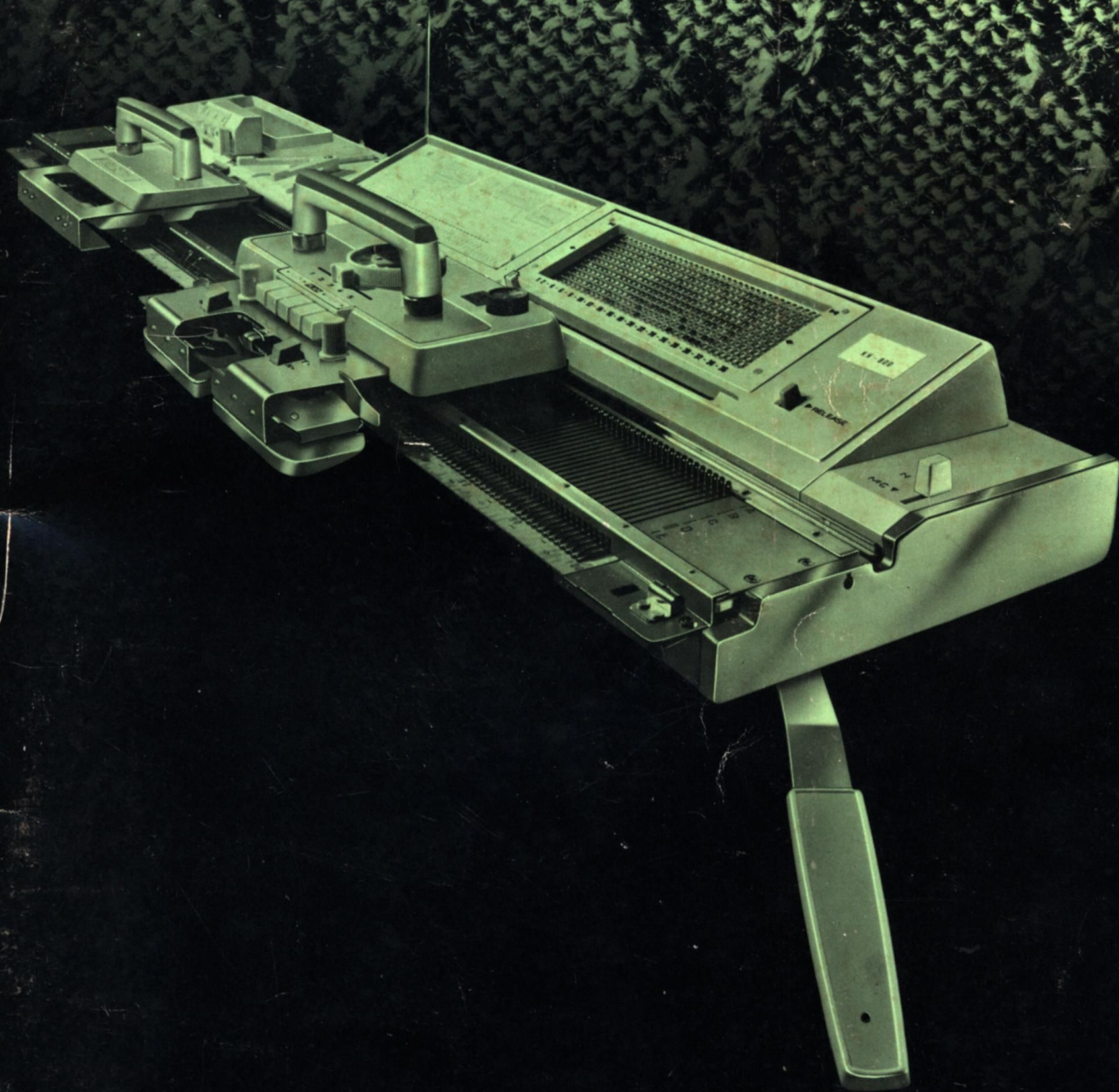

Name of parts

1

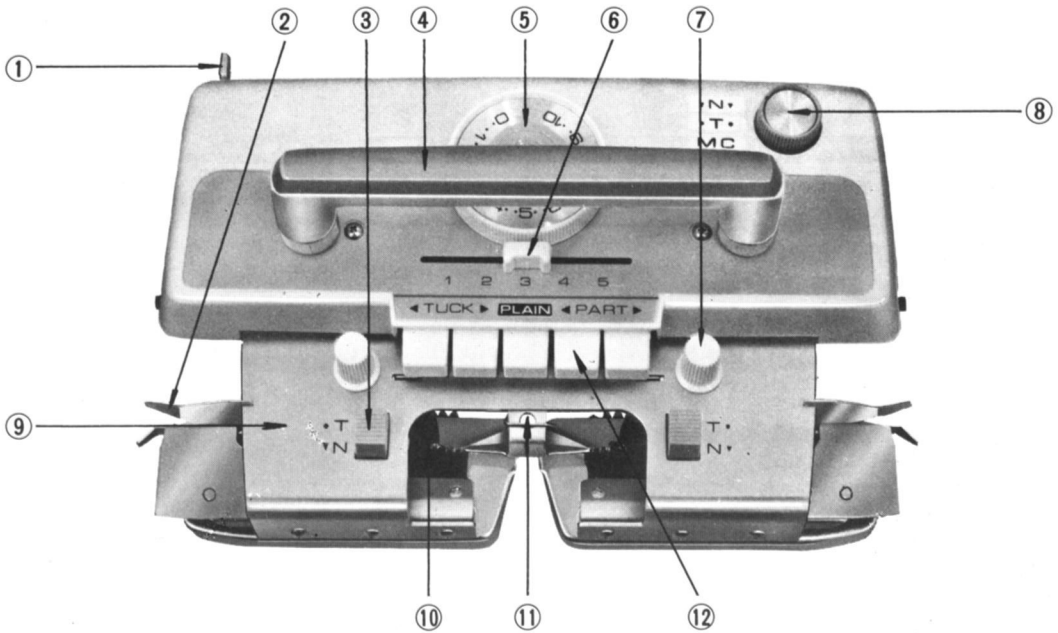

- | | |
|---------------------------------|---------------------------|
| 1. Row Counter Tripper | 7. Plastic Thumb Screw |
| 2. Laying-in Yarn Guide | 8. Change Knob |
| 3. Weaving Button | 9. Sinker Plate Arm |
| 4. Carriage Handle | 10. Weaving Pattern Brush |
| 5. Tension Dial | 11. Yarn Feeder |
| 6. Holding Cam Lever (H. C. L.) | 12. Cam Button |

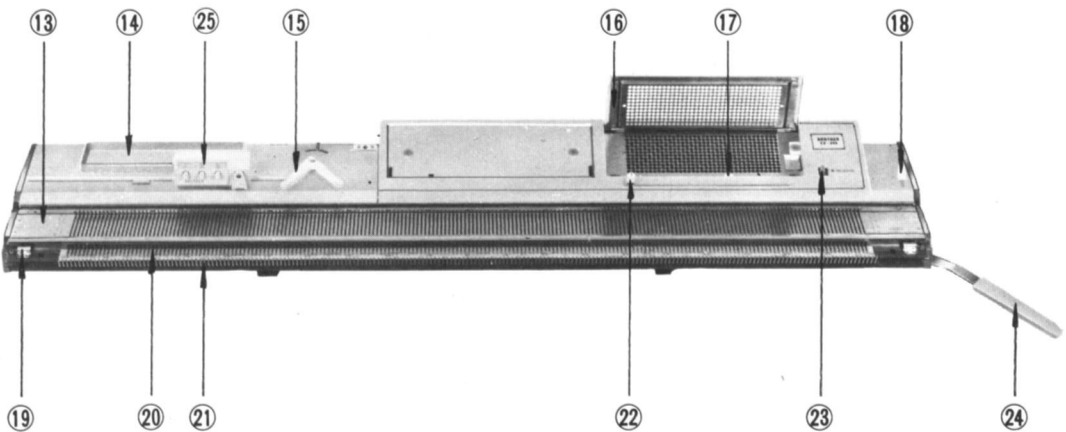

- | | |
|--|-----------------------------|
| 13. Needle Bed | 19. Extension Rail Fastener |
| 14. Accessories Storage | 20. Knitting Needles |
| 15. Feeding Lever | 21. Gate Pegs |
| 16. Card Presser | 22. Step Indicator |
| 17. Automatic Pattern Repeat Regulator | 23. Release Lever |
| 18. MC Change Lever | 24. Set-lever |
| | 25. Row counter |

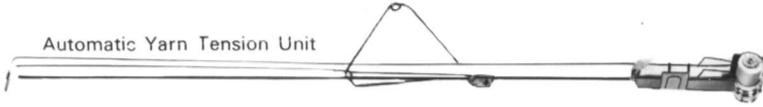

Automatic Yarn Tension Unit

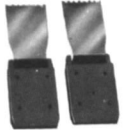

Color Weight



Extension Rail, Left

Extension Rail, Right



1/4 Needle Pusher

Cast-on Comb



Cast-on Comb, Small

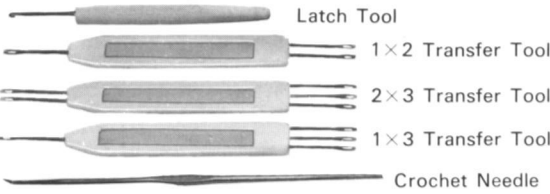

Latch Tool

1x2 Transfer Tool

2x3 Transfer Tool

1x3 Transfer Tool

Crochet Needle

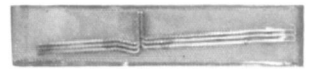

Spare Needles



Carriage Lock



Cast-on Thread

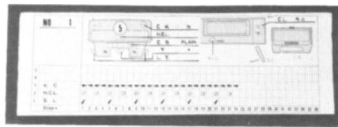

Operation Card Set



Puncher



Set Lever



Hand Brush



Table Clamps



Lubriplate



Carriage Handle

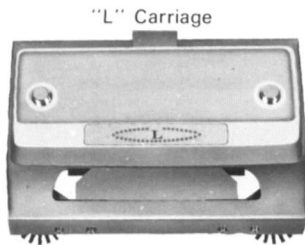

"L" Carriage

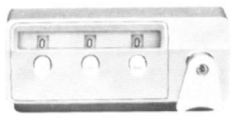

Row-Counter



Paraffin Case



Paraffin



Special Felt Pen

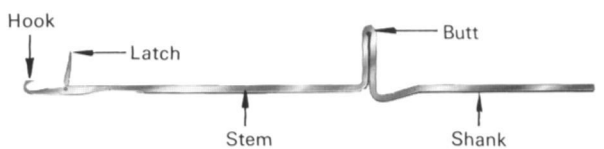

Hook

Latch

Stem

Butt

Shank

Setting up your machine

3

Place the machine on a firm table, with the carrying case handle away from you. Unlock the catches on either side of the handle. (See Fig. 1).

Lift the upper case slightly, and pull towards you to release the lid. (See Fig. 2).

Push the Release knob and open the Lid for Accessories storage. (See Fig. 3).

Take the two table clamps out of the Accessories storage. (See Fig. 4).

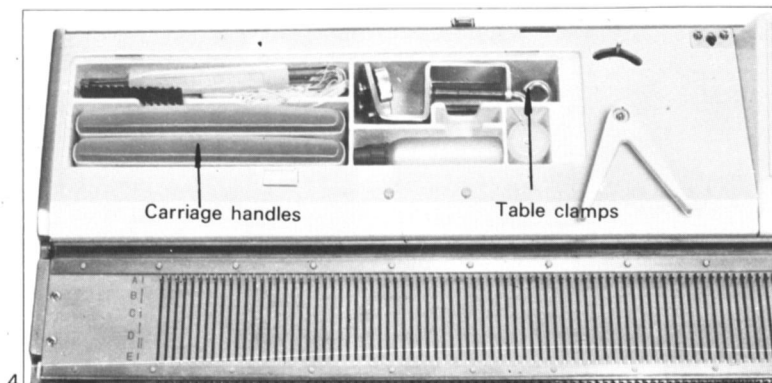
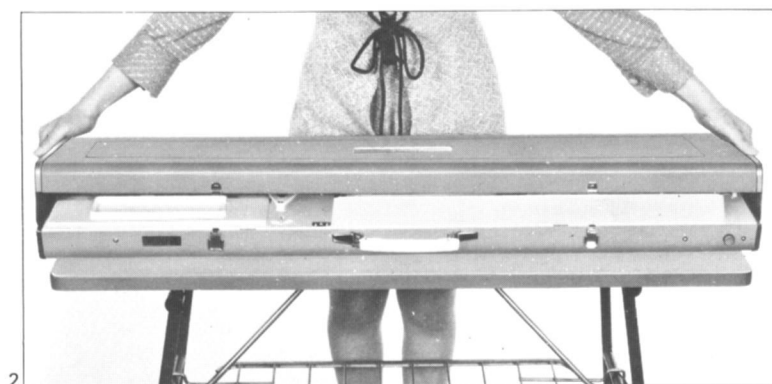
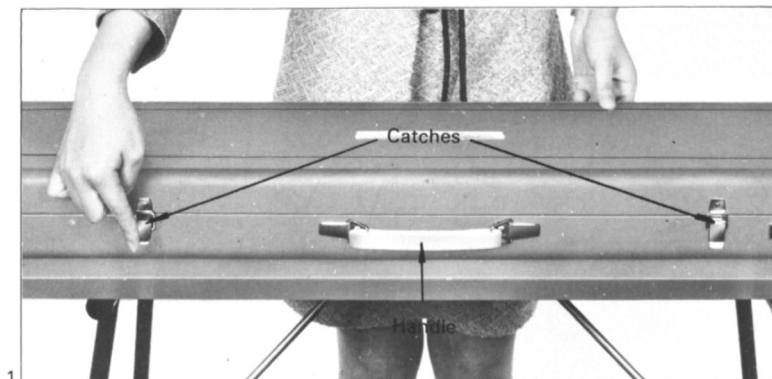

Raise the front of the machine and insert the head of the clamp into the aperture. (See Fig. 5).

Now pull the clamp upwards and turn the nut in a clockwise direction until it is secure. Fit the second clamp in the same way. (See Fig. 6).

Fasten the knitter to the table by tightening the table clamp screws. The rubber pads will prevent the table top surface from getting scratched. (See Fig. 7).

Remove the carriage lock. (See Fig. 8).

NOW YOUR MACHINE IS SECURED TO THE TABLE AND YOU ARE READY TO START FITTING THE ATTACHMENTS.

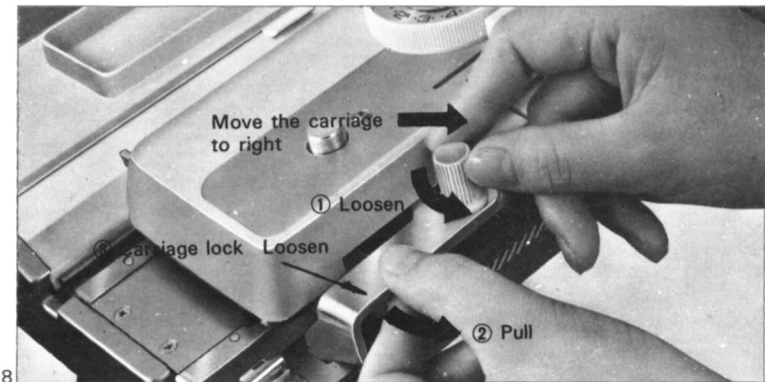
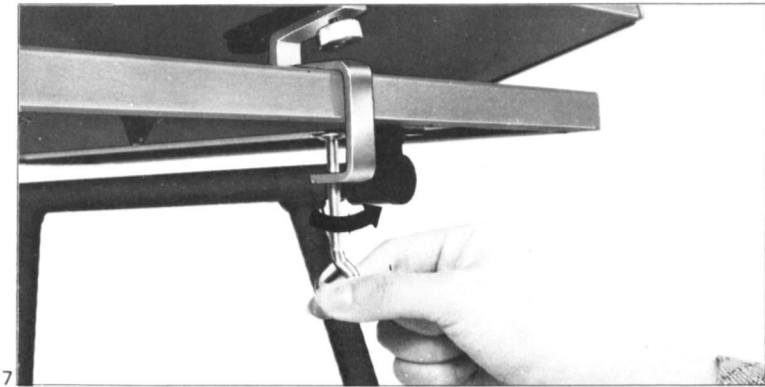
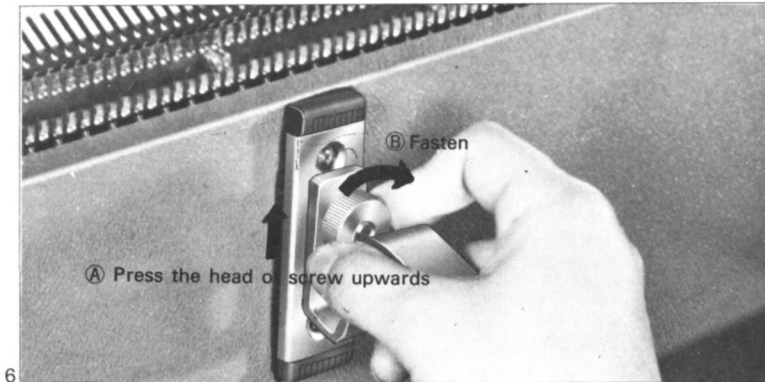
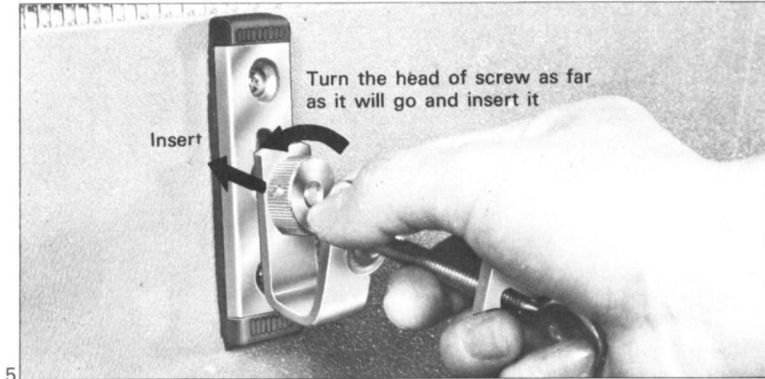

Press down the spring to release the Lacy saddle, and remove it from the carrying case. (See Fig. 9).

Press down the spring in the centre, and remove the sinker plate assembly and the Yarn Tension Unit. (See Fig. 10).

SETTING UP THE CARRIAGE

Slide the carriage to the centre of the machine. (Before doing so push back the butts of all the needles as far as they will go. Loosen the white plastic thumb screw on the carriage, and insert the sinker plate unit. Push it back as far as it will go, and tighten the thumb screws securely. Make sure that the raised metal studs line up with the holes in the sinker plate unit. (See Fig. 11).

CHECK THAT THE CARRIAGE MOVES FROM SIDE TO SIDE FREELY. (To do so all needles must be back in Position A).

Fasten the handle onto the carriage (See Fig. 12).

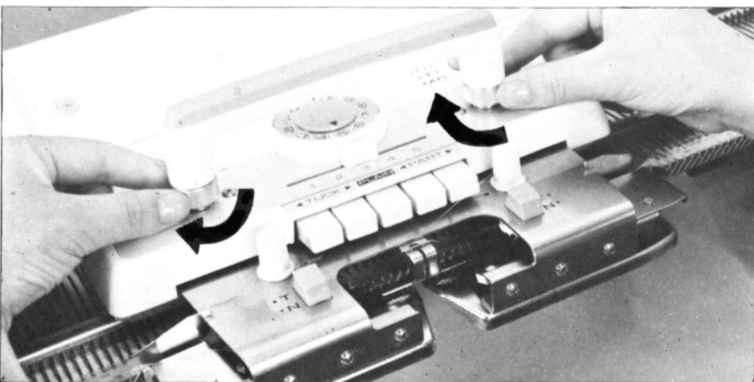
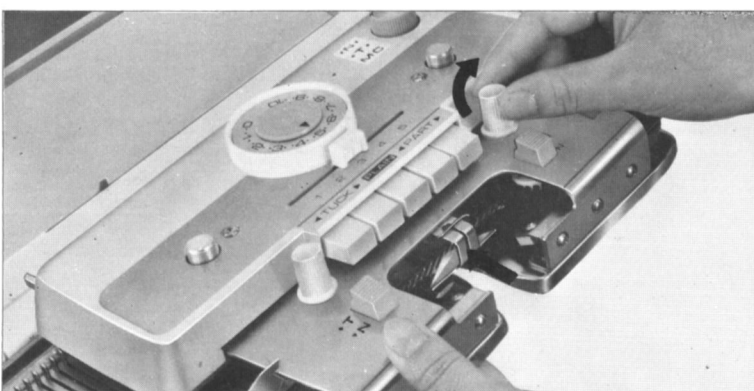
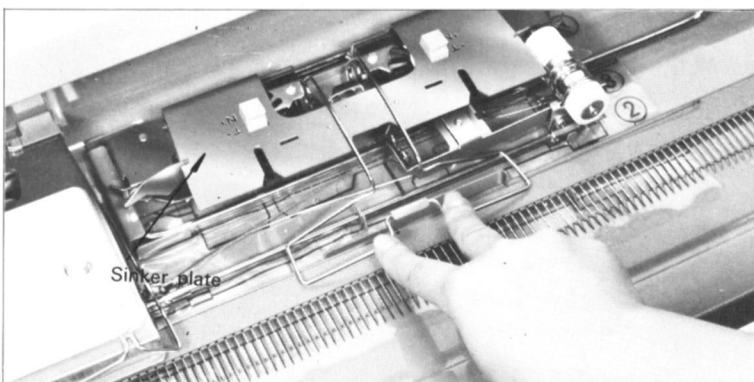
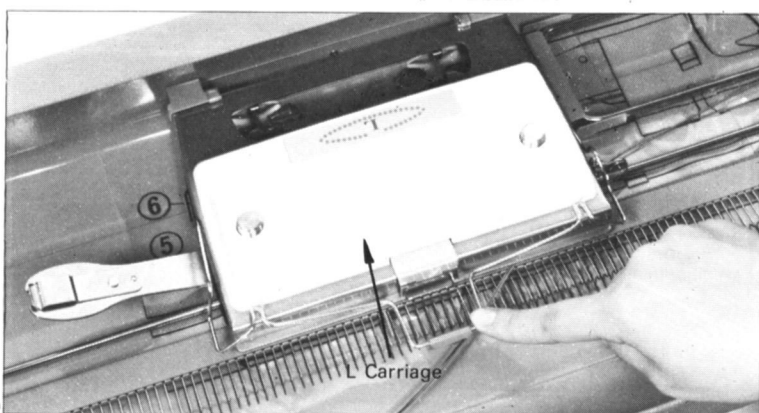

Assembling the yarn tension unit

6

As this was retained by the same spring as the sinker plate unit, it should now be free from the carrying case.

Turn the front guide arm forward in the direction of the red arrow. (See Fig. 14).

Turn back the 'take-up springs' as far as they will go. (See Fig. 15).

Raise the rear arm guide until it is perpendicular to the rod. (See Fig. 16).

Insert the end of the rod into the stand hole at the centre of the machine. The rear yarn guide should face backwards. (See Fig. 17).

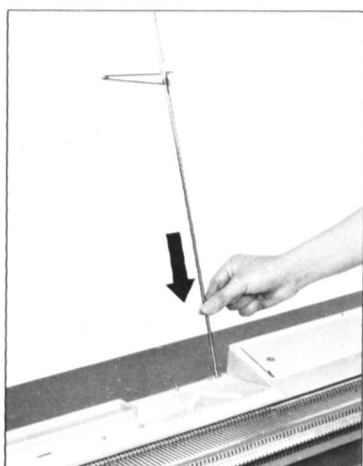
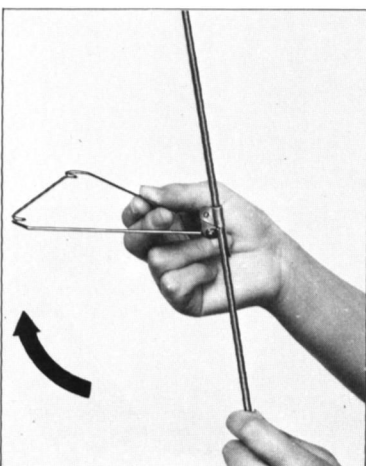
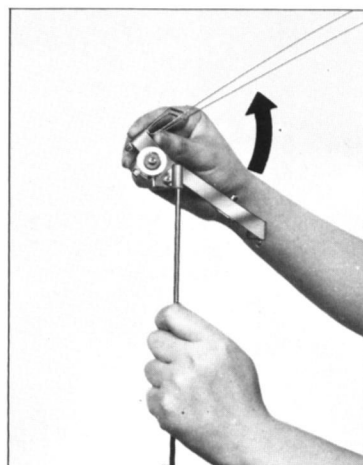
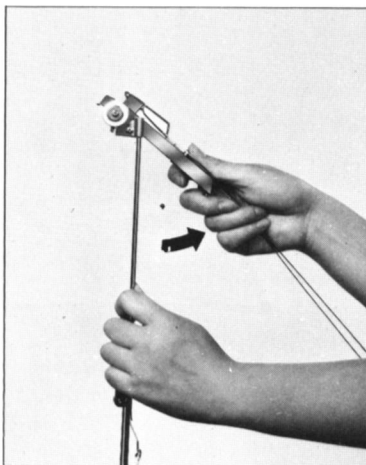
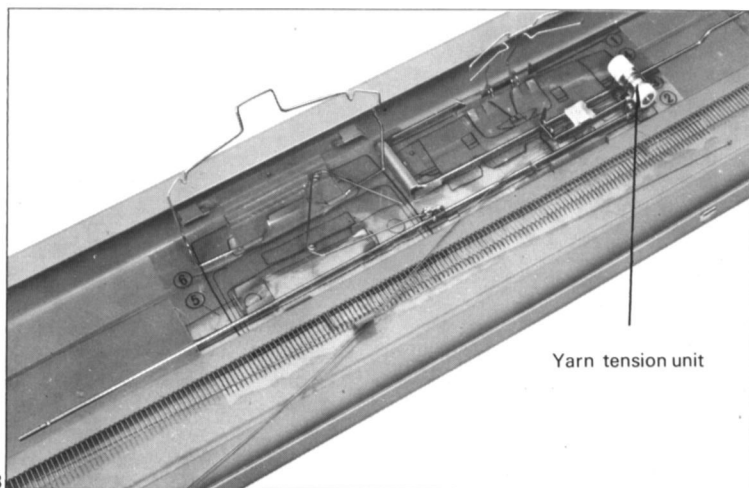

Here are a few important points to remember before you start knitting

WOOL

There are many different types of wool that can be knitted on your machine-but for the purpose of learning or practicing, it is best to use a standard 3 Ply yarn. Choose a good quality, one that can be knitted over and over again.

WINDING THE WOOL

The wool you purchase will be wound in either balls or hanks, both of which unwind slowly when knitted by hand. Machine knitting is much faster, and requires that the wool be loosely wound so that it unravels freely. You should therefore re-wind all wool into a ball, using a wool winder. This way you can also make sure that there are no knots or flaws in the wool-that you might otherwise discover too late. If you do discover any knots, try to ensure that they come at the end of a row and not in the middle of the knitting. (See Fig. 18).

WAXING THE WOOL

For thicker wools or wool of uneven texture it is recommended that you wax the wool before using. To make this easier for you we have built into the Yarn Tension Unit a special wax stand, which automatically applies a small amount of paraffin wax to the wool as it passes through the unit. Waxing will smooth the small hairs in the wool, and allow it to run through the machine easily. All traces of the wax will disappear after the garment is pressed. (See Fig. 19).

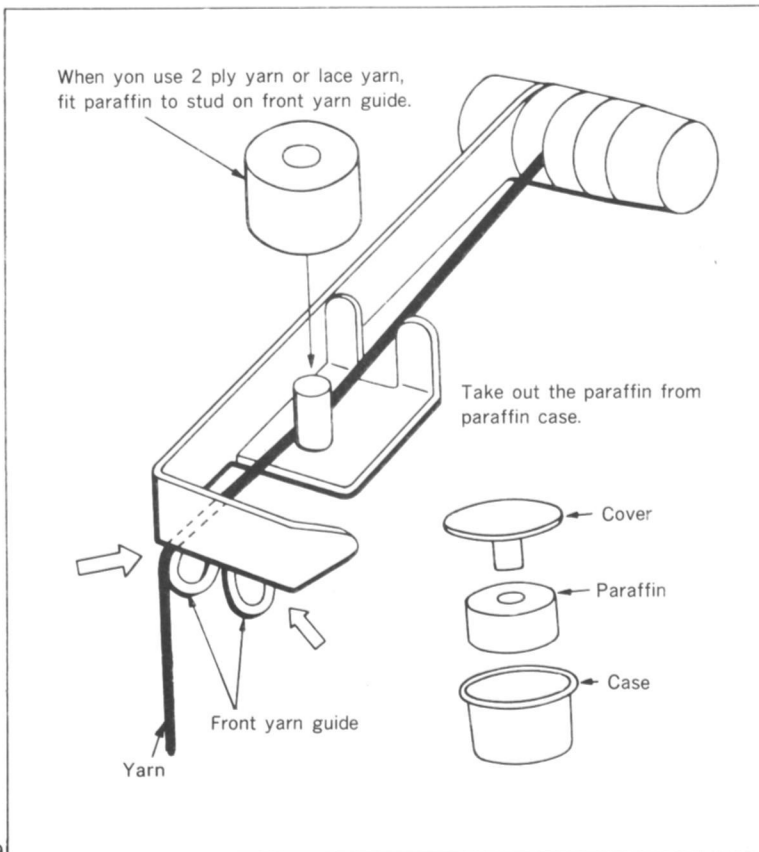
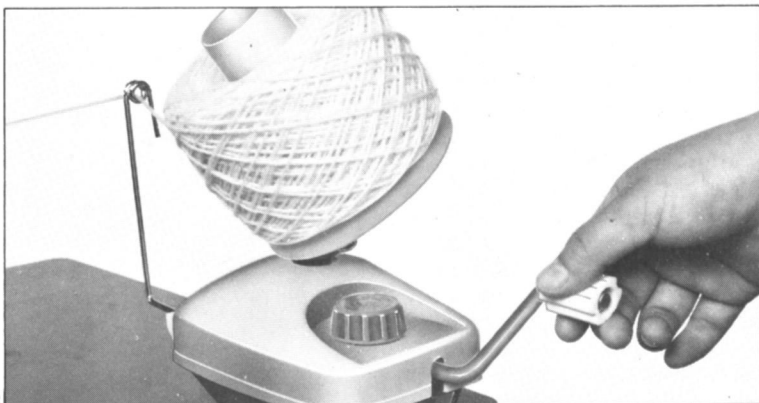

WOOL TENSION

The tension that the wool will feed into the machine at is governed by the unit at the top of the Yarn Tension Unit. The spring discs allow the wool to pass through easily or tightly—depending upon the thickness of the wool. A tight tension (towards the +) is used for thin yarns and a loose tension (towards the -) for thick wools. The tension we recommend for a 3 Ply wool is where the two arrows meet. (See Fig. 20).

20

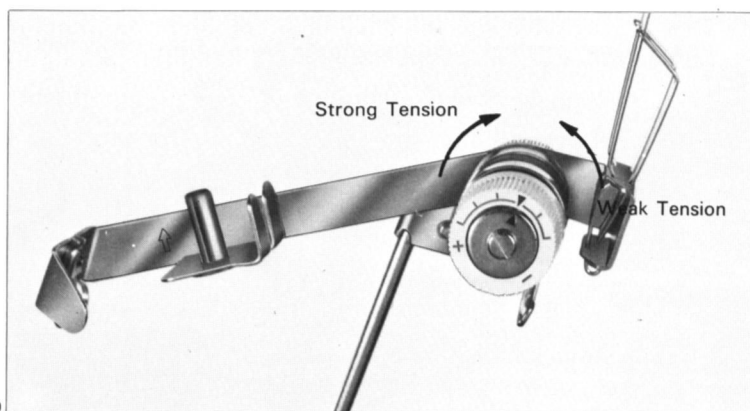

TENSION DIAL

The size of the stitch is determined by the tension setting on the Carriage tension dial. This dial is graduated from 0 to 10, each space being subdivided into three parts. 0 denotes the tightest tension (i.e. the smallest stitch) and 10 the largest tension (i.e. the loosest stitch). The tension at which your garment is to be knitted is usually given in the knitting pattern instructions, but as this is liable to differ for different brands of wool, it is advisable always to knit a tension swatch sample before commencing your garment. (See section on "Knitting your first garment"). (See Fig. 21).

21

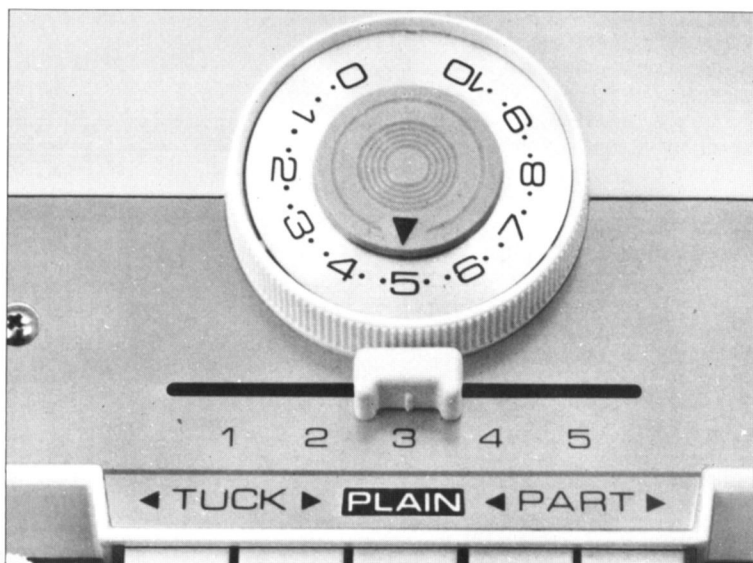

NEEDLE POSITIONS

On either side of the needle bed there appear the marks A, B, C, DI, DII, & E. These are the five needle positions. (See Fig. 22).

A—Non working position.

Needles will not knit.

B—Working position.

Used for general work.

C, DI, DII,—Pattern, Lacey & Fairisle positions.

Used for various pattern stitches.

E—Holding position.

The stitch will 'hold' on the needle until released. Used for shaping e.g. pockets and buttonholes.

22

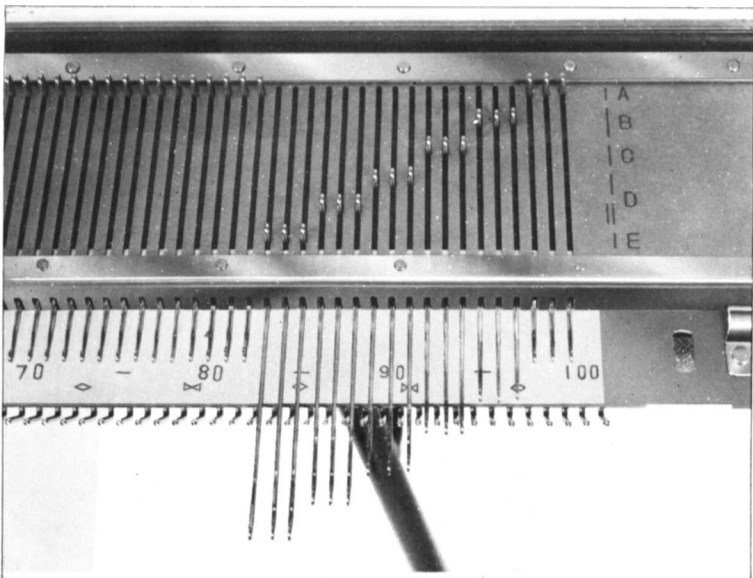

IT IS IMPORTANT TO REMEMBER THAT THE CARRIAGE SHOULD NOT BE MOVED ACROSS THE NEEDLE BED UNLESS ALL THE NEEDLES ARE ALIGNED IN EITHER OF THE FIVE POSITIONS.

23

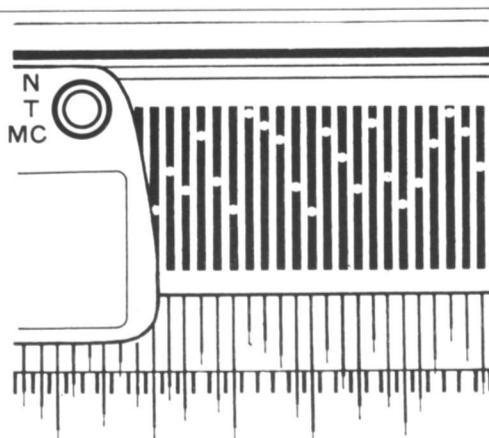

WRONG

24

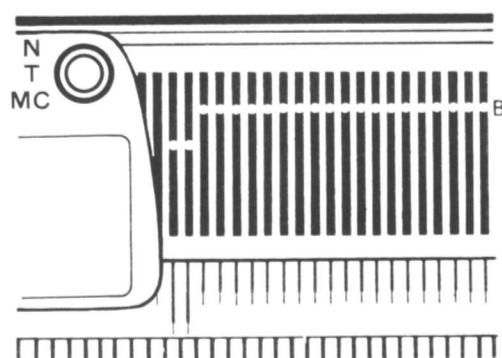

WRONG

25

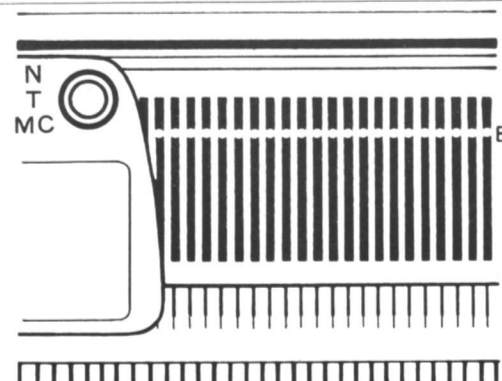

RIGHT

Functions of the carriage

10

The movement of the carriage across the needles in action (Position B), automatically knits each needle in turn ; thereby knitting one row. Once the carriage has been moved across the needles in one direction, it cannot be returned until that row has been completed. At the end of a row you will hear a "click" from the carriage, which signifies that the row has been completed and you can return.

It is advisable not to move the carriage too far away from the end needles after completing a row, as this will tend to slacken the tension in the springs on the return movement.

CARRIAGE BUTTONS

There are five buttons on the front of the carriage. They are used for various stitch patterns to set the carriage to enable it to knit various stitches. The arrow above the button shows that the carriage is set for that direction. If both buttons are depressed together, the carriage will be set for both directions.

PART : These buttons are used mainly for fair-isle and similar patterns. When using the PART buttons, the H.C.L. must be on Position 3. If both buttons are in, and the needles are not set, the carriage will move across needles without knitting the stitches.

PLAIN : This button is pressed only to cancel any of the other buttons previously set. It does not remain in.

TUCK : These buttons are used to form 'tucking' stitch patterns. When using them, the H.C.L. must be on Position 3. (See Fig. 26).



26

HOLDING CAM LEVER (H.C.L.)

The H.C.L. has five positions marked on the carriage, 1, 2, 3, 4 and 5. And these positions are explained following chart.

Position of H.C.L.	Carriage Knitting to Left	Carriage Knitting to Right
1	II **	II
2	III ***	III
3	I *	I
4	III	I
5	I	III

*

I : This is a Normal position. All needles set forward to C, DI, DII, or E positions will return to working position B.

**

II : Intermediate position. This position is used when knitting a "V" neck, Round neck Arm hole and etc. with a pattern.

III : Holding position. Any needles brought forward to positions C, D, or E will not knit if the H.C. closest to the knitting is on III.

CHANGE KNOB

There are three settings on this control. (See Fig. 27).

N. For normal knitting, part and tuck patterns.

T. For laying in or weaving patterns.

MC. For fairisle. When the change knob is set on MC all the needles knit in position DI. Knitting in this position does not harm the machine but there will be a little more noise than normal.

ROW COUNTER

The figures on your row counter can be moved to zero by turning the dials anti-clockwise in order from the right (See Fig. 28).

When using the row counter, Set the tripper to working position. If you do not wish to use the row counter, then pull the tripper back to resting position. (See Fig. 29).

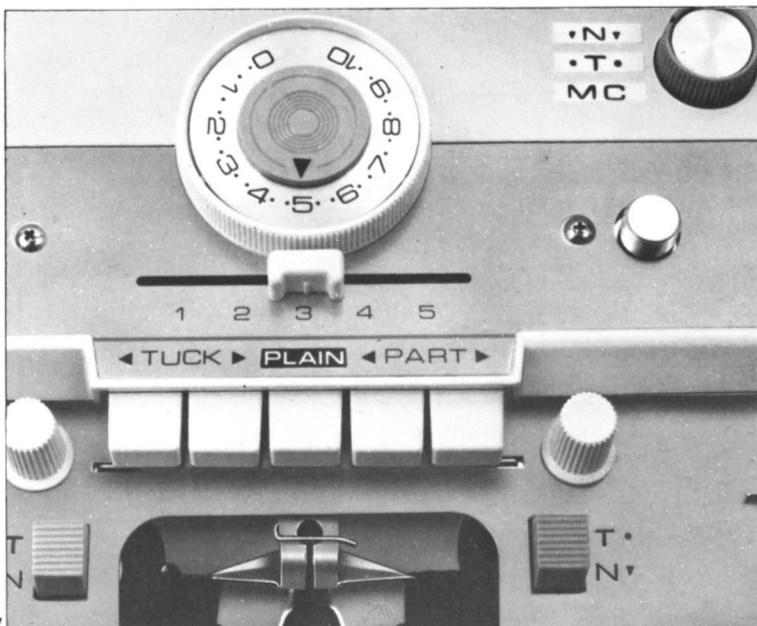

27

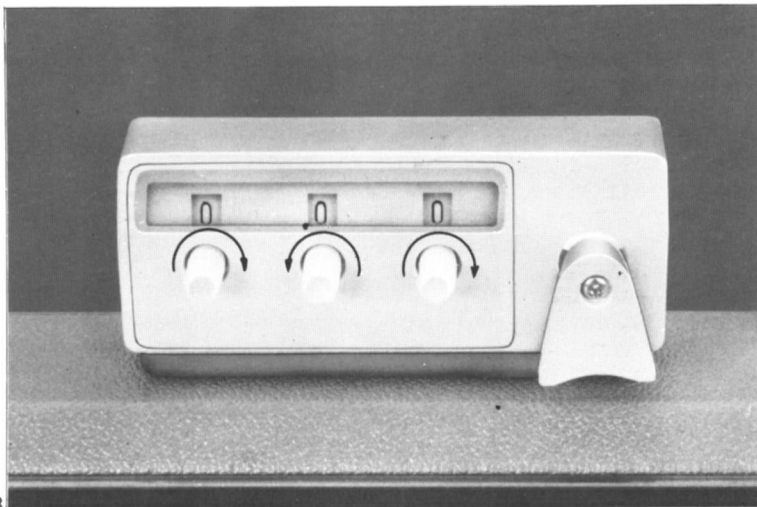

28

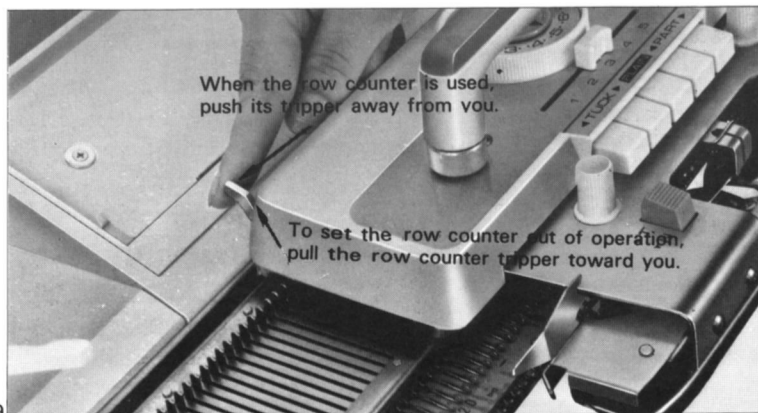

29

How to reset the Row counter
*The Row counter is already
fixed to the machine.

However, you can remove it
if you do not wish to use the
row counter.*

Set the row counter onto the
two studs-and push it away
from you. (See Fig. 30).

Fit the set-lever onto the shaft
under the needle bed.

However, if you knit together
with the Ribbing Attachment,
fit the set-lever onto the
shaft at the rear right of the
needle bed. (See Fig. 32).

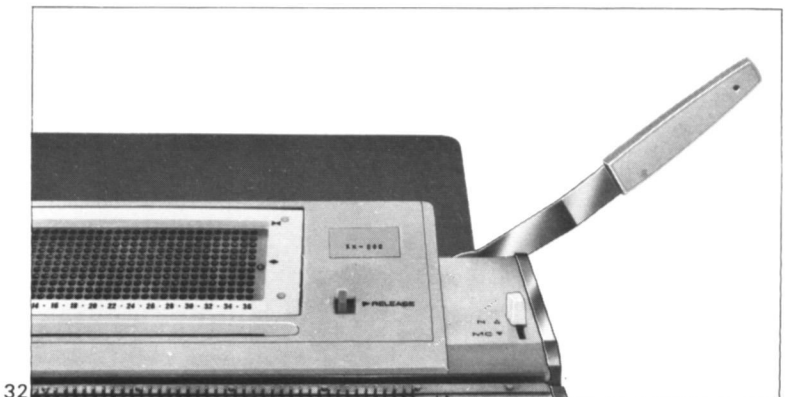
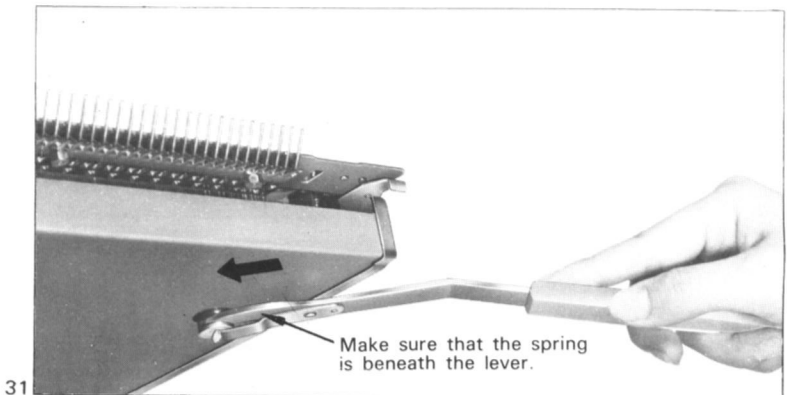
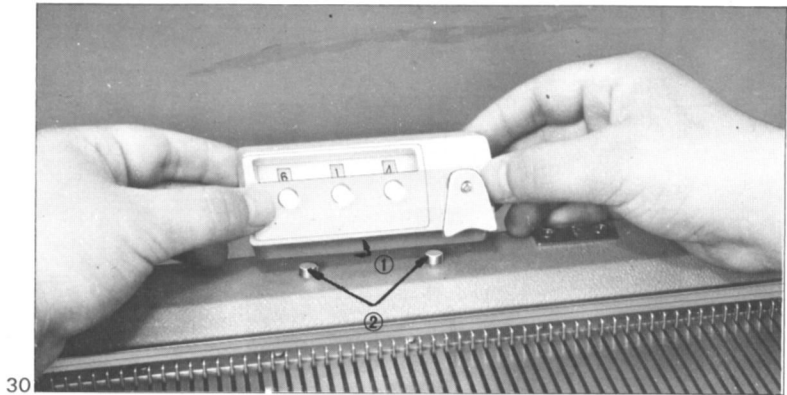

Preparing to knit

STEP ONE—

The Carriage. (See Fig. 33). The photo shows the various controls of the carriage that you should remember the names of.

- (1) Set the tension dial to 7 (for 4-ply wool).
- (2) Push both weaving knobs to N.
- (3) The Holding cam lever to Position 3.
- (4) Press center carriage button—PLAIN.
- (5) Move the carriage across to the right side of the machine.

STEP TWO—

The Needle Bed. (See Fig. 34). (1) Bring forward by hand 40 needles to Position B, 20 on either side of the center mark "O".

- (2) Move the carriage across and back to straighten these needles completely.

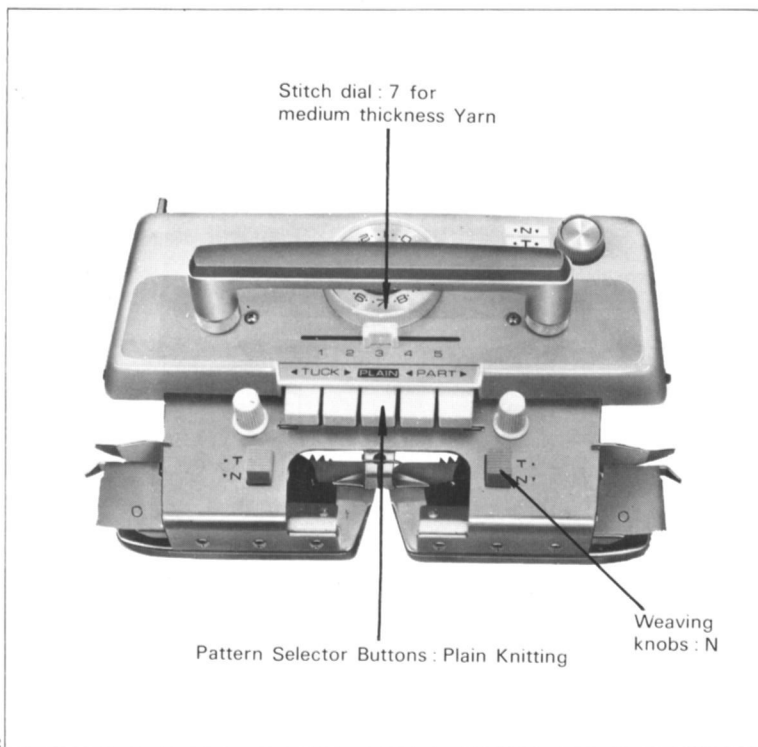

33

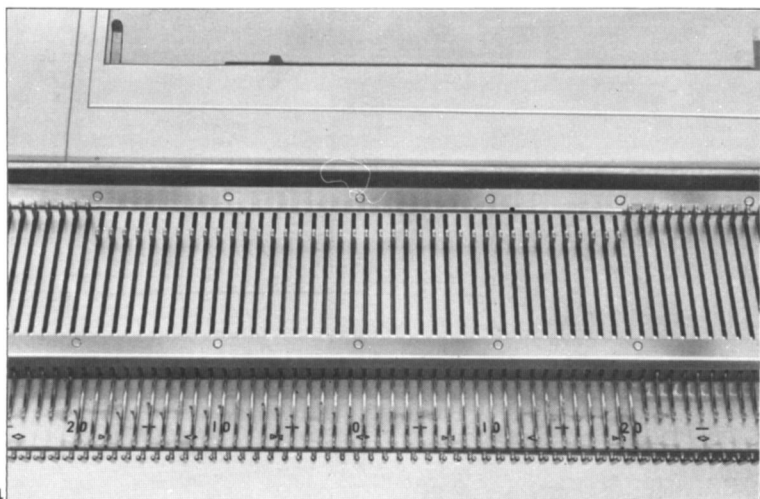

34

STEP THREE—

THREADING THE YARN TENSION UNIT (See Fig. 35, 36, 37).

- (1) Pass the wool from the ball through the rear yarn guide as shown in fig. 35.
- (2) Take the wool **in front** of the yarn guide and in between either of the two sets of discs, **from behind.** (See Fig. 36)
- (3) Pass the wool through the yarn guide on either side of the center stud (See Fig. 37). You need not use the wool wax for 3-ply wool.
- (4) Thread the front of the yarn guide (See Fig. 37).
- (5) Thread the wool into the eyelet of one take up spring (See Fig. 36).
- (6) Now clip the wool under the wool holder half way down the rod where it will remain until you are ready to start knitting.

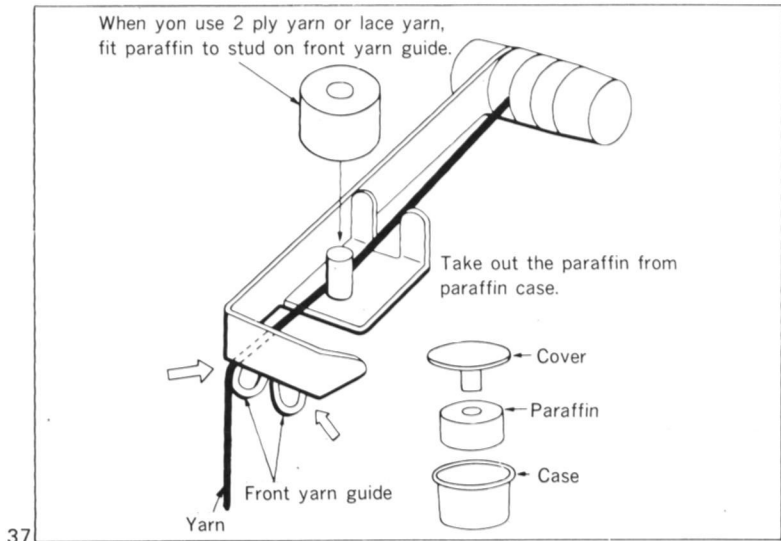
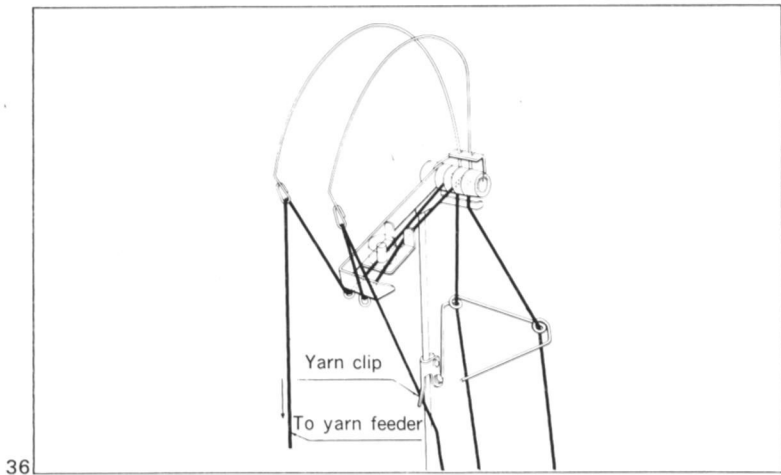
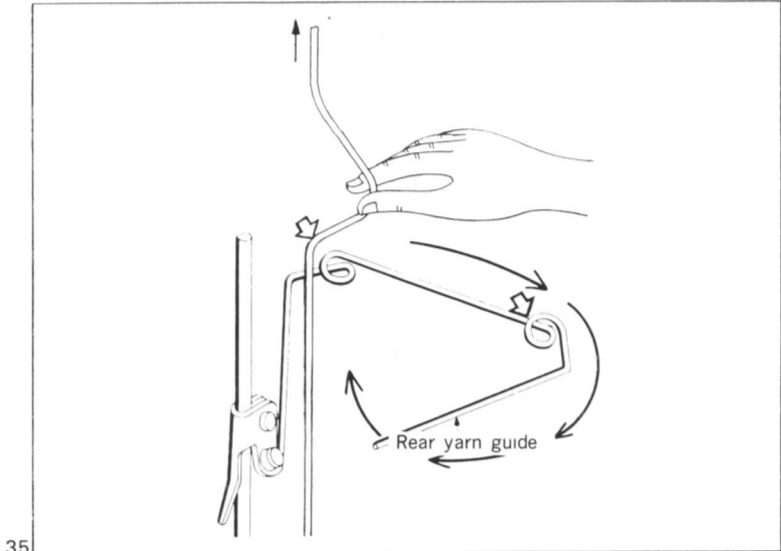

STEP FOUR—**CASTING ON.**

(1) Hang the cast on comb onto the pegs of the needle gate making sure that the clips on the comb slip over the part of the gate peg that is below the needle bed. Use the small cast on comb and center it between the 50th needle on the right and left. SET THE TENSION DIAL TO No. 7 (3-PLY WOOL) (See Figs. 38 & 39).

(2) Take the end of the wool (which was clipped onto the yarn tension rod) and thread it into the yarn feeder of the carriage. Hold it from below with your left hand and from above with your right. (See Fig. 40).

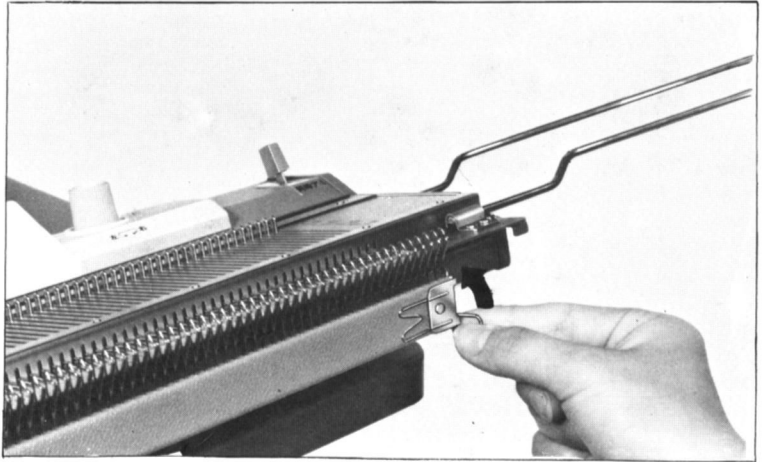

38

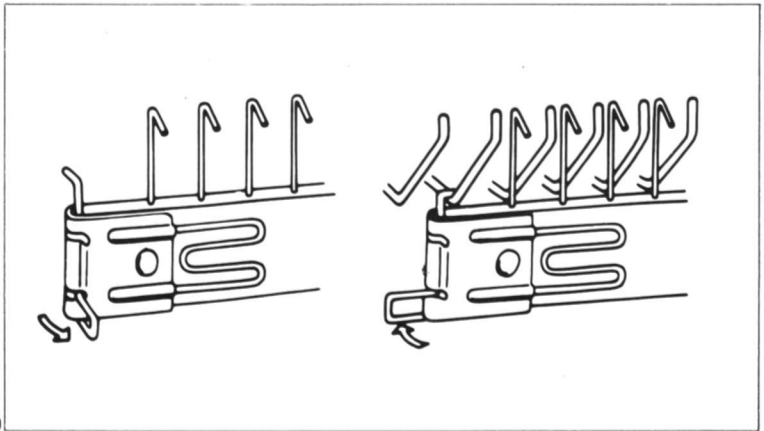

39

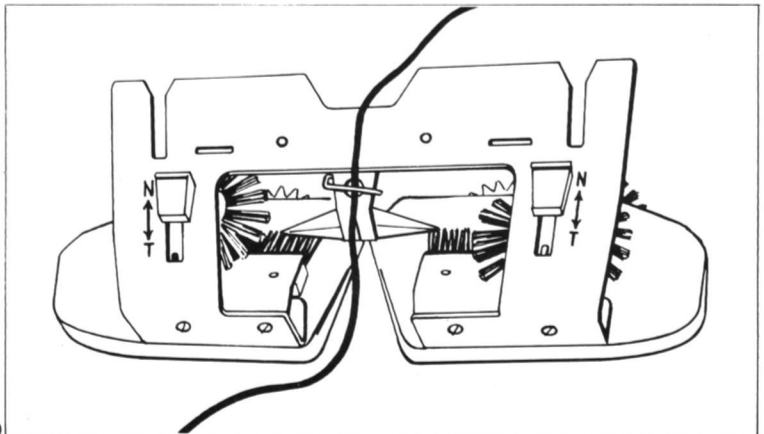

40

(3) Push the wool back into the yarn feeder. It should click into place. (See Fig. 41 & 42).

(4) Continue to hold the wool below with your left hand, and take back any slack wool through the yarn tension unit (i.e., the take up spring should be bent forward).

(5) Still holding the wool below the carriage with your left hand, slide the carriage across the needles with your right hand until you hear a "click"

41

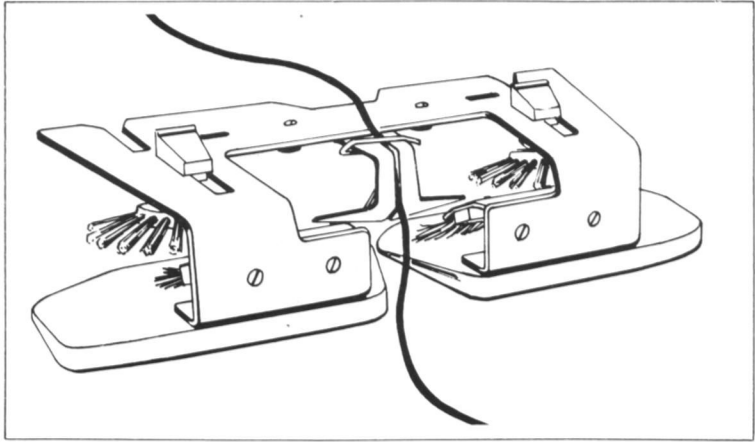

N. B. Always move the carriage across until you hear the click at the end of a row.
You will now have a loop around each needle and under each peg of the comb.

42

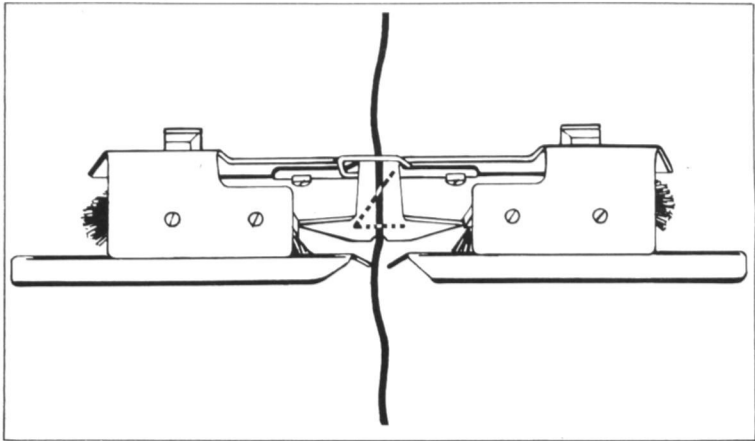

(N. B. If a few end needles have been pulled forward from Position B then simply push them back by hand before continuing).

(6) You can now lower the cast on comb by turning the end pegs (at the **same** time) towards you. This will release the comb from the gate pegs and you can allow it to drop, slowly. (See Figs. 43 & 44).

Note : The cast-on loops are still loose so take care not to turn the comb out of a vertical position or the loops may fall off.

(7) Raise the thread from the comb to the carriage, so that it goes under the last comb peg, adjacent to the end needle and above the rest.

(8) Knit the next row slowly and continue knitting. The cast on comb can be removed after the first 6 or 8 rows by tilting it backwards. After a few rows, remove the knitting from the machine (i.e., taking the thread out of the yarn feeder and knitting one row across). Practice this cast on two or three times. (See Fig. 45).

YOU ARE NOW ABLE TO DO A QUICK OPEN END CAST ON. THIS METHOD IS NOT USED WHEN PRODUCING GARMENTS – BUT IS USEFUL FOR KNITTING SWATCH SAMPLES AND EXPERIMENTING.

ALTERNATE METHODS OF CASTING ON ARE GIVEN FURTHER ON.

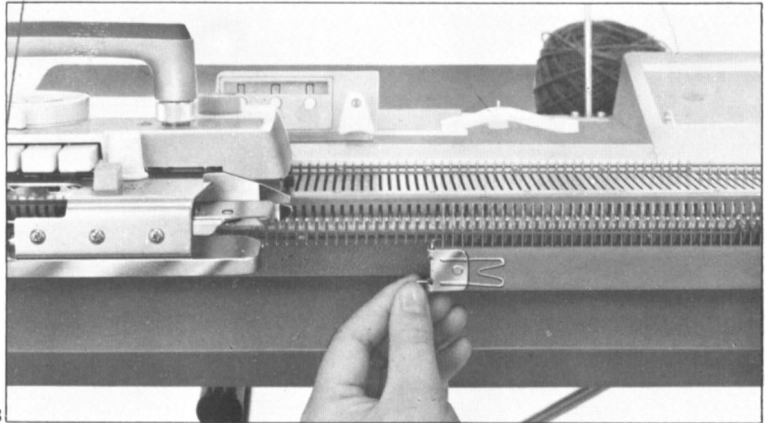

43

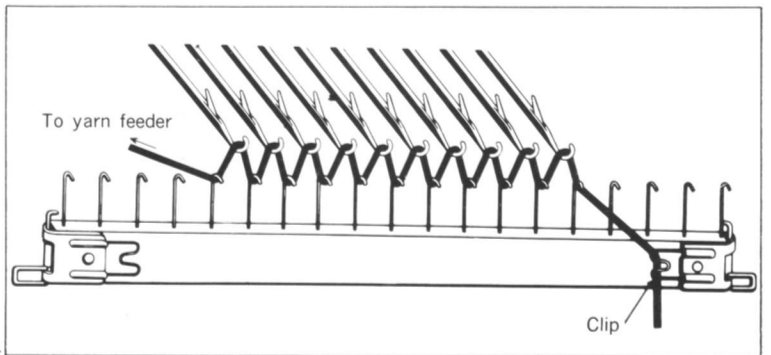

44

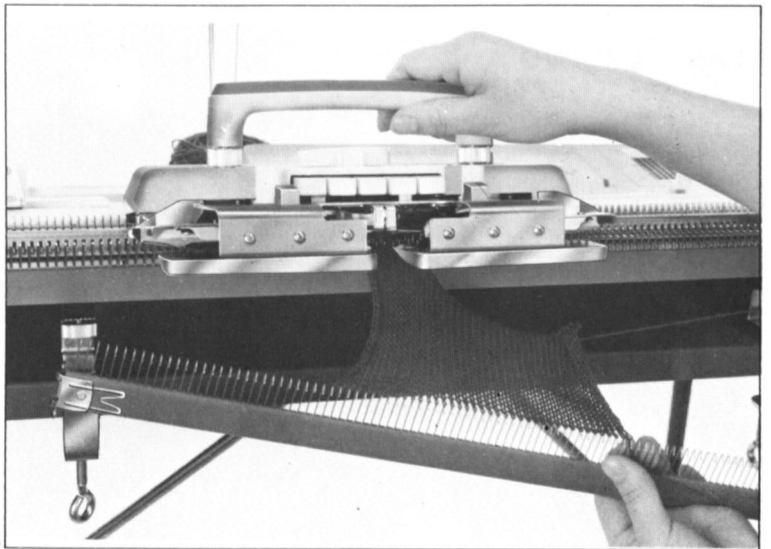

45

The purl side (or wrong side) of the knitted fabric (facing you) looks like this. (See Fig. 46).

The plain side (right side) of the fabric (away from you) will look like this. (See Fig. 47).

IF THE CARRIAGE SHOULD JAM AND HOW TO UNRAVEL A ROW

(See Fig. 48).

(1) Loosen the thumb screws of the sinker plate and remove the sinker plate from the carriage.

(2) Holding the handle tilt the carriage backwards and slide it back to the side from where that row commenced. When it is clear of the end needles in action lower the front again onto the needle bed.

(3) With the yarn still in the yarn feeder, return the sinker plate to the carriage and tighten the thumb nuts securely.

(4) Unravel the last row of knitting. (see below).

UNRAVELLING A ROW OF KNITTING

(1) Pull the yarn slightly sideways and up. (See Fig. 49). The stitches will come off the needles and the stitches from the row below will slip onto the needles.

(2) Continue to pull the yarn sideways and up removing 4 or 5 stitches at a time until you reach the spot where the carriage was jammed.

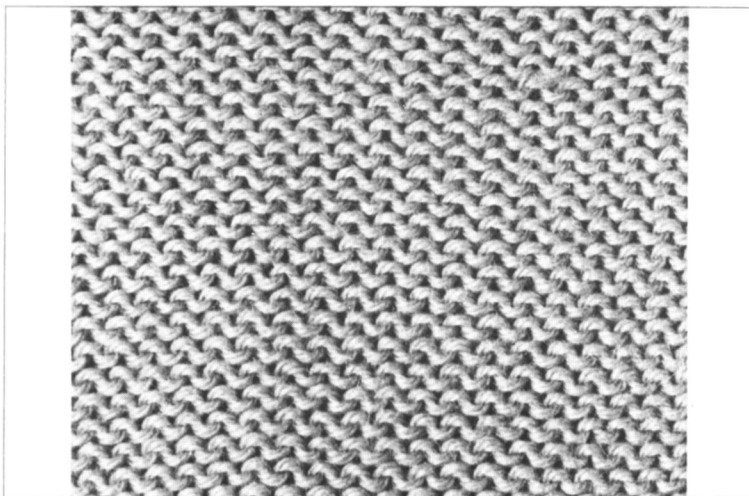

46

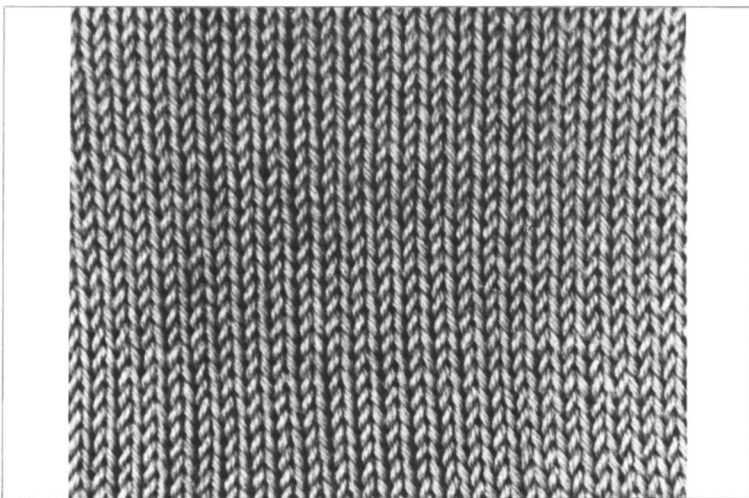

47

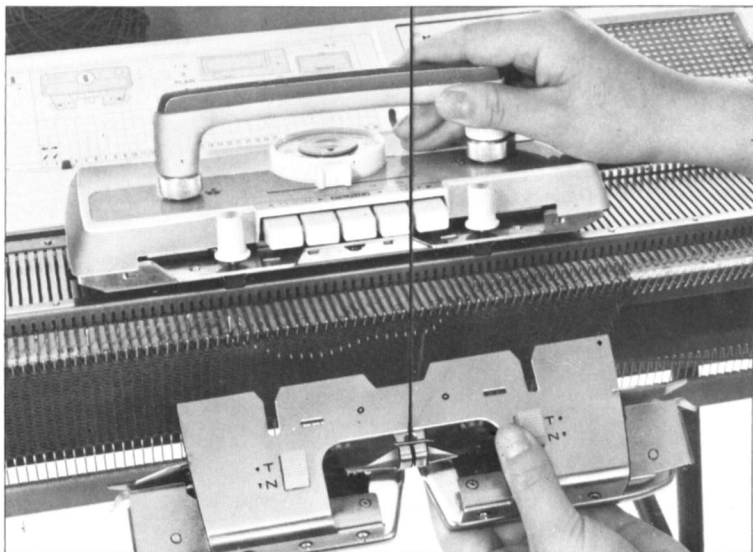

48

(3) Pull the yarn down from the rear (above ball) to take up the slack and to bring the take of spring back into action.
 (4) Ensure that there is no slack from the carriage to the needles by sliding the carriage left and right a few inches (NOT ACROSS NEEDLES IN ACTION). (See Fig. 51).

(5) ADJUST THE NUMBERS ON YOUR ROW COUNTER.

IF YOU FIND IT NECESSARY TO MOVE THE CARRIAGE ACROSS THE NEEDLES IN ACTION WITHOUT KNITTING A ROW — Then press both PART buttons in at the same time and set the H.C.L. to 2. If any needles have been selected then pull them back to B position before going across with the carriage.

BEFORE CONTINUING: LET'S LOOK HOW A STITCH IS FORMED.

(1) The stitch is on the needle which is behind the gate pegs.
 (2) The carriage brings the needle forward by pushing the needle butt.
 (3) The stitch pushes the latch back and falls behind it.
 (4) The new thread (from the yarn feeder on the carriage) is laid into the needle hook.
 (5) The carriage brings the needle back and so doing the previous stitch gets pushed forward again — this time right over the latch (by-passing the hook).
 (6) The newly laid thread gets pulled in to from another stitch,

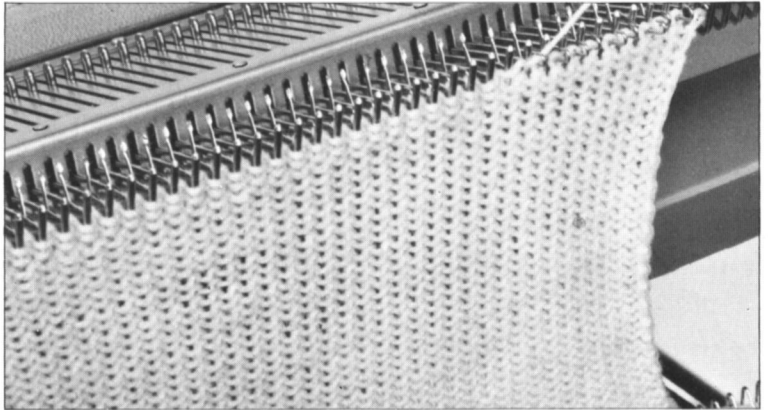

49

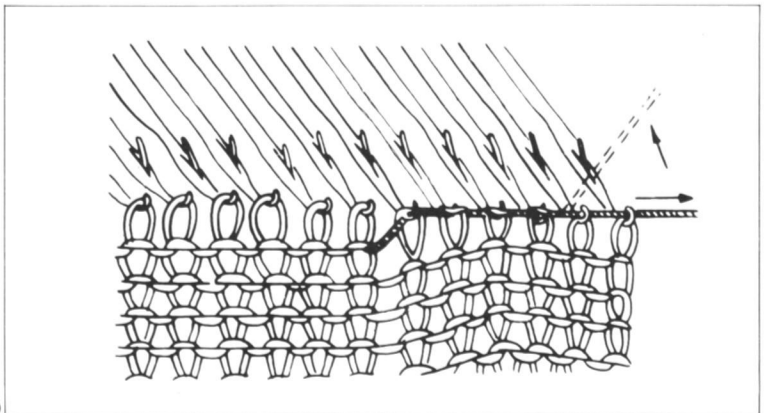

50

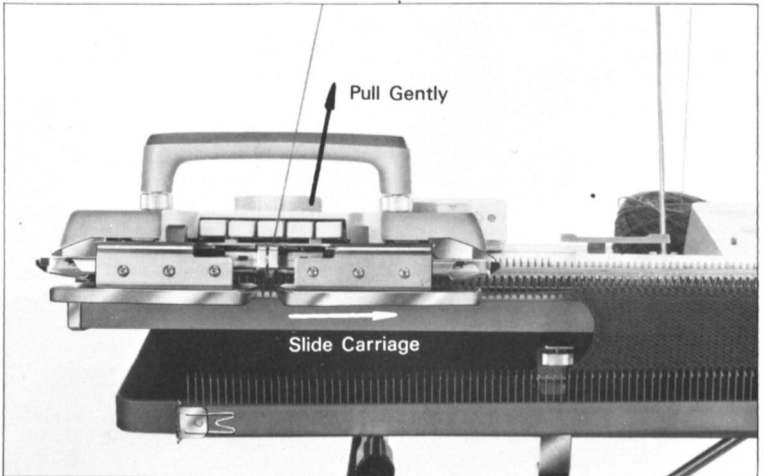

51

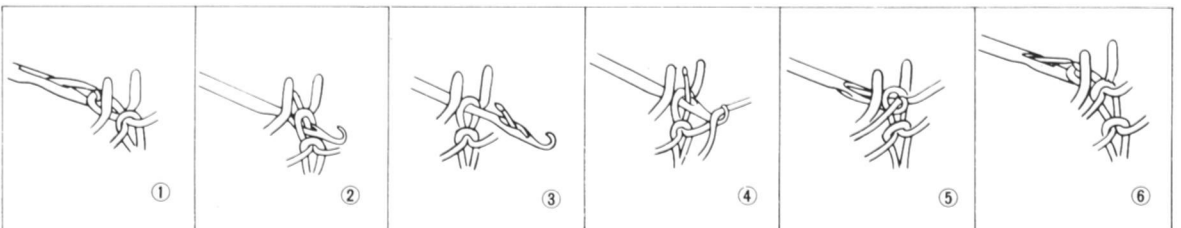

Now lets knit a plain hem

20

Bring forward the required number of needles (evenly divided on either side of the centre 'O') to working position B. Slide the carriage across these needles to straighten the needle butts.

CARRIAGE SETTING

Center Button — PLAIN.

H.C.L. — 3.

Change knob N.

Tension Dial — 7 (3-ply wool).

Carriage on the right.

MACHINE SETTING

Thread the yarn tension unit using waste wool (or any contrast color yarn). Cast on (as previously shown using the cast on comb) and knit 8 or 10 rows plain. Remove the cast on comb from the knitting.

(1) Tighten the tension by two numbers lower (i.e., 5).

(2) Thread the waste wool below the yarn feeder and re-thread the machine with the wool to be used.

(3) Set row counter back to 'O'.

(4) When the yarn is threaded into the carriage hold it below with one hand and knit across with the other.

(5) Knit approx. 20 or 30 rows or as required for double the depth of hem.

(6) Using the single eyed transfer tool open the latches of the needles as shown (refers to Fig. 52).

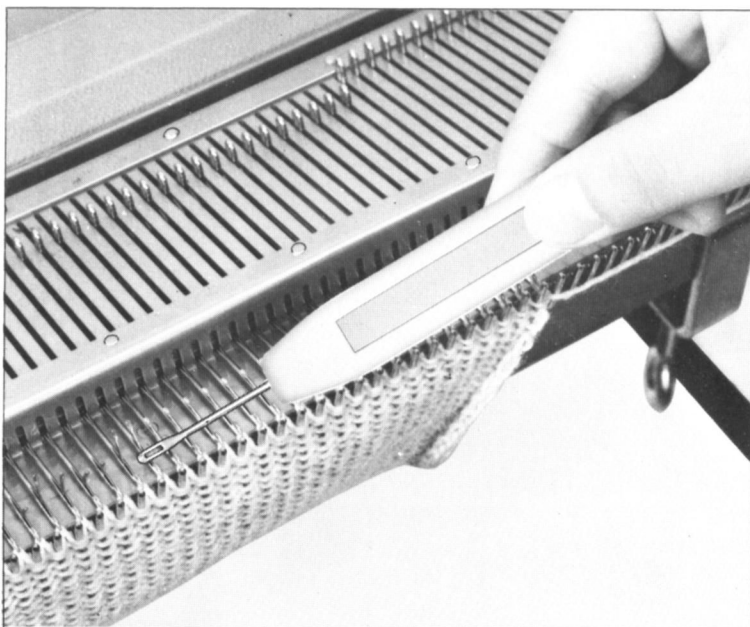

TURNING THE HEM

Pick up the first stitch (away from carriage) of the first row where it meets the contrast color row. (N. B. DO NOT PICK UP THE CONTRAST COLOR STITCH). Insert the transfer tool into this stitch and lay the tool over the hook of the needle.

(2) Hold the work forward with your left hand and pull the transfer tool back and up with your right. This brings the needle forward to E Position and slips the stitch from the tool onto the needle. (N. B. If you intend to do the next row in a pattern stitch that required the needles to be in B Position — then do not pull the transfer tool back, but simply raise it upwards so that the stitch falls onto the needle. **Make sure that the needle does not come forward enough for the two stitches to fall behind the latch**).

(3) Continue raising the first row of stitches in this manner until all the needles have two stitches on them.

(4) Reset the tension dial to 7 and take up any slack in the wool from the knitting to the carriage.

(5) Continue knitting the garment.

REMOVING THE WASTE WOOL

Once the garment has progressed few inches you can remove the waste wool by breaking the end stitch of the row joining the knitting and pulling the loose thread at the other end of this row.

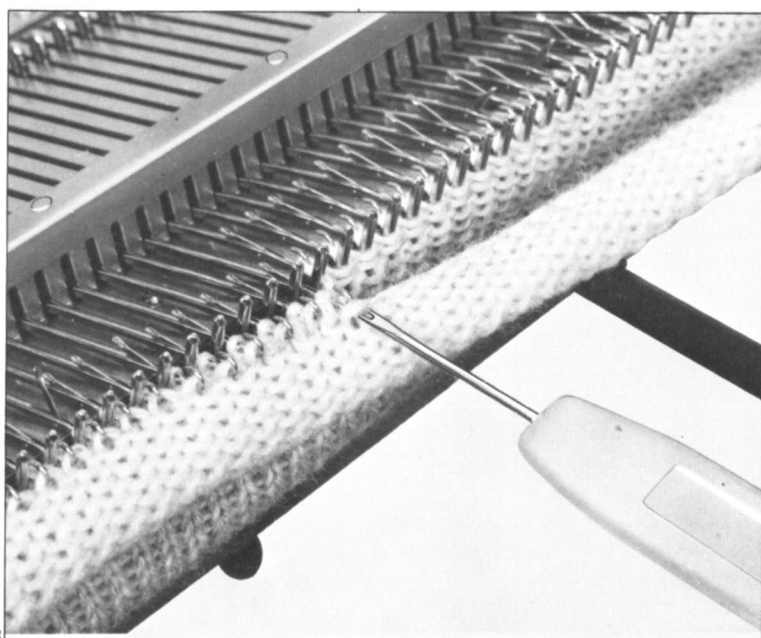

53

Now lets try an elastic hem (i.e. continental or double 'rib')

22

Using the 1/1 needle pusher, bring forward the required number of needles to B position. (Bring every alternate needles forward to B position.) The other needles must be in A position. And move the carriage across and back to align all the alternate needles in position B.

(1) Thread up and cast on with waste wool as before. (When the comb is dropped it should catch the first row as illustrated in No. 54).

(2) After knitting 8 or 10 rows of waste wool break the wool and re-thread with the wool to be used. Lower the tension to 2. (3) Knit approx. 40 or 50 rows. (See Figs. 55 and 56).

(4) Bring forward all the empty needles from Position A to Position B, by hand and make sure that all the latches are open.

(5) Using the one eyed transfer tool and starting from the end opposite the carriage pick up each stitch from the first row (where it joins the waste wool) and raise these onto the empty needles. (See Fig. 57).

(NOTE : As explained under 'plain hem' when raising these stitches the needles can be brought forward to E Position to ensure that the stitches do not drop off — or they can be left in B Position).

(6) Return the Tension dial to 7 and after knitting a few inches the waste wool can be removed.

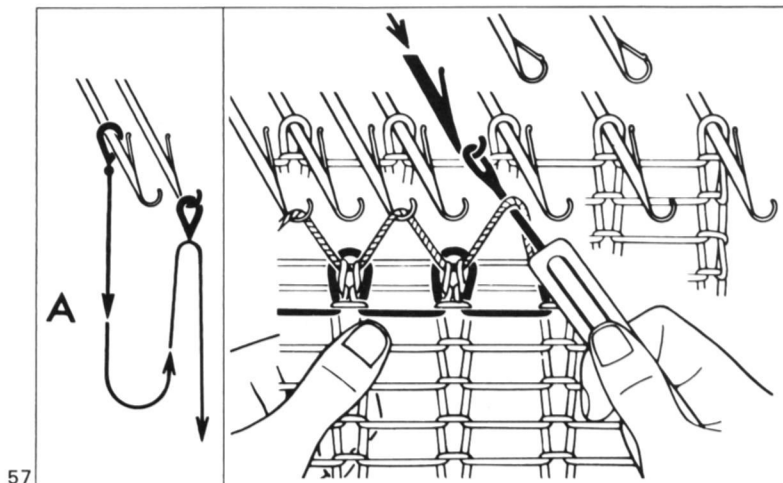
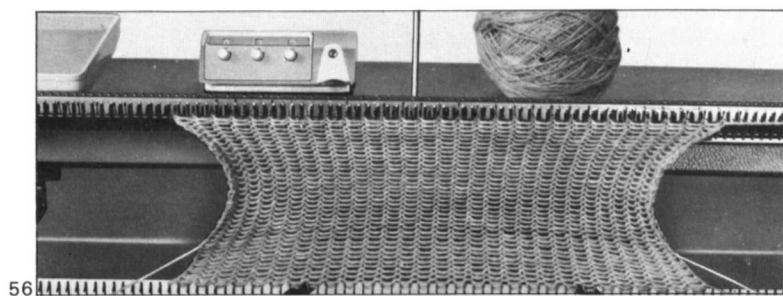
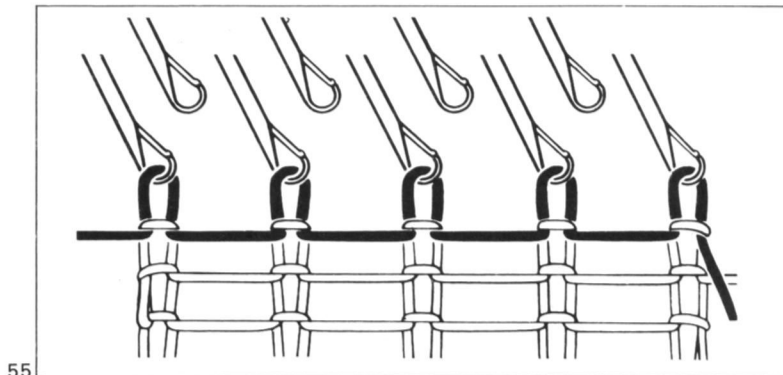
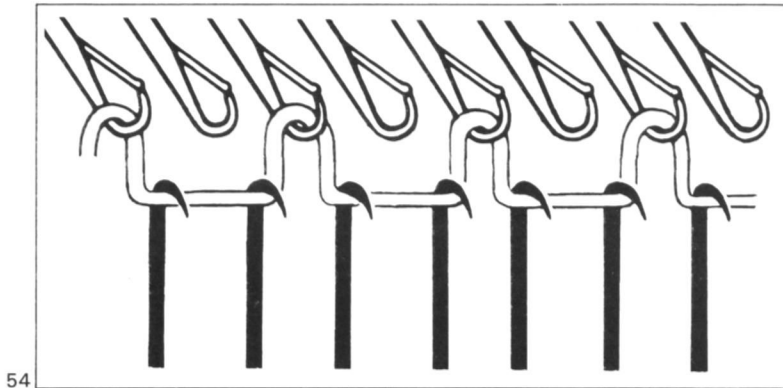

**THE FINISHED
"DOUBLE RIB"
SHOULD LOOK LIKE
THIS**

(See Fig. 58).

MANY variations of this elastic rib can be made for cuffs and hems. One of the more popular is the 2 x 1 Double Hem — the instructions of which are given here.

(1) Bring forward the required number of needles to B Position and push back every third needle to Position A (out of action). (See Fig. 59).

(2) Follow the previous instructions for the 'continental rib', but when raising the first row of stitches (adjoining the waste wool) — put them onto the adjacent two needles to the left (See Fig. 60).

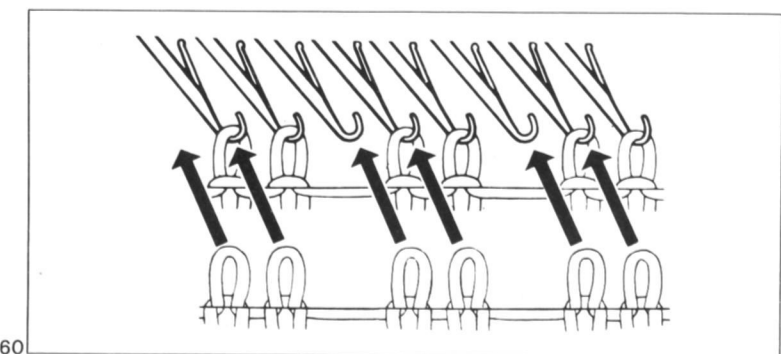
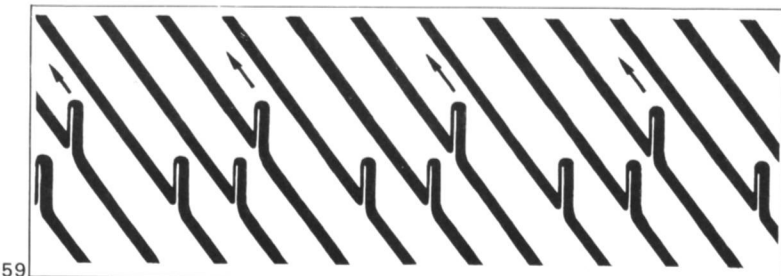
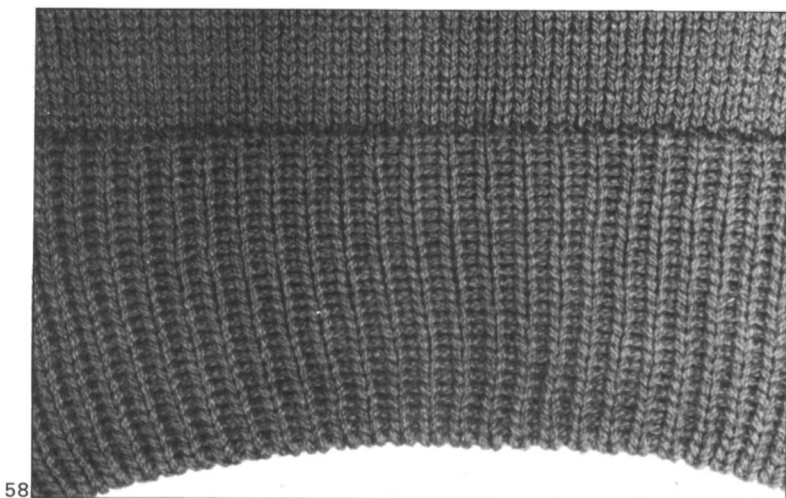

**THE COMPLETED
2 x 1 RIB WILL LOOK
LIKE THIS**

(refers to 61)

So far you have learned to cast on with a double hem — now let's see some other methods of casting-on.

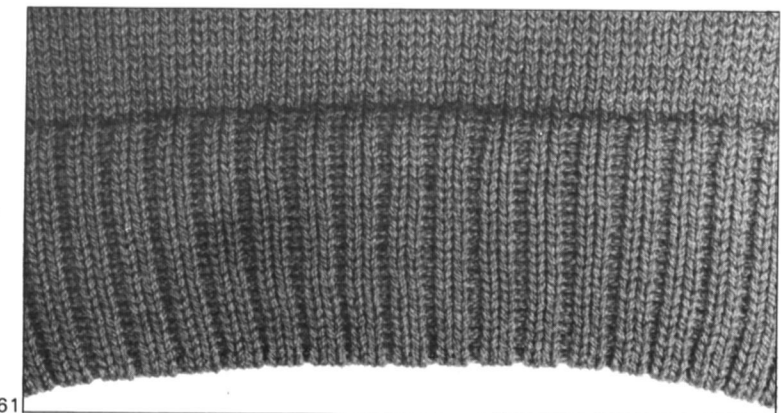

Automatic cast-on

24

Automatic Cast on

CARRIAGE SETTING

H.C.L. on position 3.
Change knob—on N.
Weaving knobs—on N.
Tension dial—5 (for 3-ply yarn).
Carriage button—both PART in.

MACHINE SETTING

Put the No. 8 pattern card into the place. And set the Pattern repeating regulator at the black line. (Step 2)

Bring forward the required needles to B position and swivel the set lever to bring out the needles.

- (1) Thread the yarn into the Carriage and knit one row (loops will form on needles).
- (2) Swivel the set-lever and knit one row. Hold the end of the yarn loosely with one hand.
- (3) Repeat the step 2 twice.
- (4) Press the center carriage button "PLAIN" and knit the next two rows slowly—and continue knitting.

This edge is not the neatest you can produce ; and we do not recommend this method if it is to be on view. However if it is to be folded in, or simply used for sample swatches, then it is the quickest sealed edge cast—on possible.

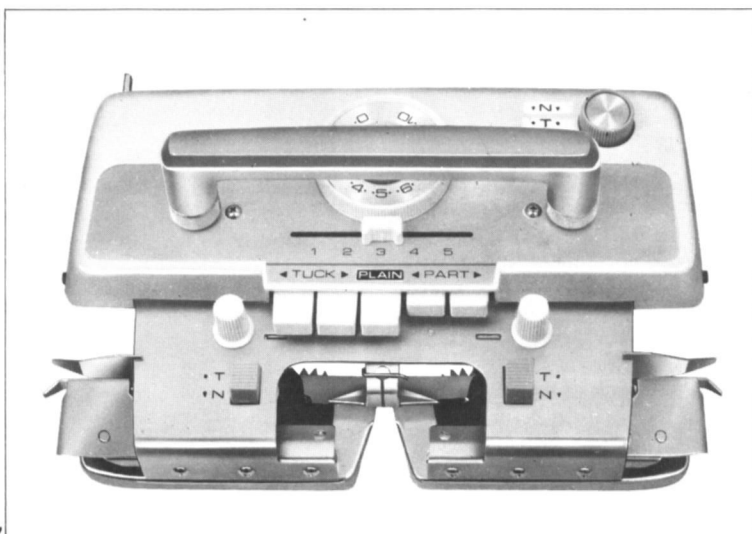

62

Finished edge cast-on (hand method)

Finished Edge Cast on Hand Method

Place the carriage on the right and set the Tension Dial to 5. Hang the cast on comb onto the pegs of the needle gate.

(1) Bring forward to Position E, all the needles required.

(2) Fasten the end of the yarn (threaded only through the yarn tension unit) onto the end needle on the left, using a slip knot.

(3) Loop the yarn around each needle from left to right, counter clockwise. The loops must be pushed back on the stems of the needles. To control these loops as you wind, hold your thumb under the last one before making another. Do not make the loops too tight. (See Fig. 63).

(4) Now thread the yarn into the feeder, and pull the strand (coming from the ball) down, to take up any slack.

(5) Gently move the carriage to the left to knit the first row.

(6) Lower the comb onto the stitches and see that the yarn goes above the comb pegs that are not opposite needles in action. Leave the comb suspended until about 10 rows have been completed.

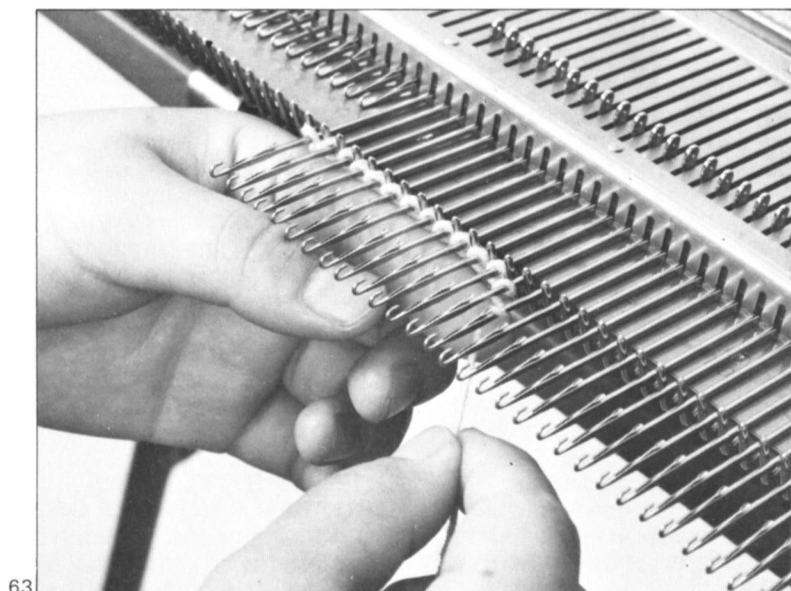

63

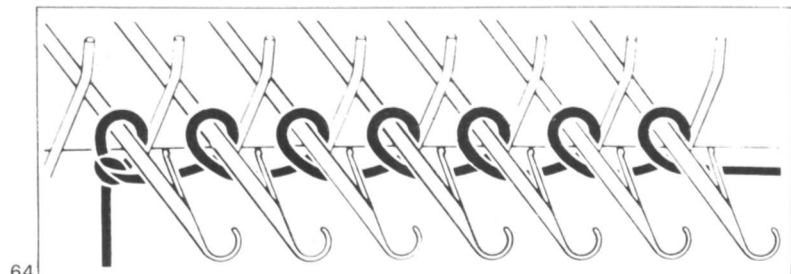

64

Knitting a picot hem

Picking up dropped stitches

26

Picot Hem

Set the machine as for the 'PLAIN HEM' and knit up to half the depth of the hem with the Tension Dial two numbers lower than required for that wool—5 (i.e., if the hem is to be 50 rows then knit up to the end of the 25th row, starting from where the main wool joins the contrast color).

Place the Lace Carriage (See section on Lacy knitting) onto the needle bed.

Bring forward every alternate needle to D I position (Using the Pattern card No. 8 and swivelling the set lever or using the 1/1 needle pusher) If an end needle (away from carriage) is set then push it back to Position B by hand. Slide the Lace carriage across the needles in one movement. (This will transfer every second stitch to the adjacent needle—automatically).

Reset the Tension Dial to 7 and take up any slack in the yarn from the carriage to the knitting.

Bring all the empty needles into a straight line together with the others in Position B. Knit the other half of the hem (i.e., 25 rows) and raise the first row of stitches as for the 'PLAIN HEM'.

Dropped Stitches

A. IF THE STITCH HAS DROPPED ONE ROW, then with the single transfer tool pick up the stitch and the unknitted thread and put them both on the empty needle. Push the needle forward, until the stitch falls just behind the latch of the needle; catch the thread of the unknitted stitch into the hook of the needle, and ⁶⁵ push the needle back. The stitch will slide over the closed hook of the needle and be re-knitted.

B. IF THE STITCH HAS DROPPED A NUMBER OF ROWS, then insert the latch hook into the last stitch that has not dropped, from behind the fabric (i.e., the side that is not facing you).

(1) Hold the latch hook at right angles to the knitting, and pull the knitting down slightly.

(2) Push the tool towards you. The stitch will fall behind the latch. (See Fig. 65).

(3) Now pull the tool back, at the same time catching the thread across in the hook. Make sure to position the hook in the centre of the horizontal thread, and to pull, the tool all the way back until the stitch is formed. (See Fig. 66).

(4) In the same way knit the stitches all the way to the top stitch.

(5) Place the transfer tool (or a crochet hook) into the hook of the latch tool, and transfer the last stitch onto the transfer tool. Now place the stitch onto the empty needle. (See Fig. 68).

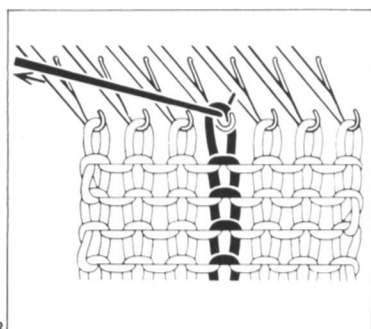
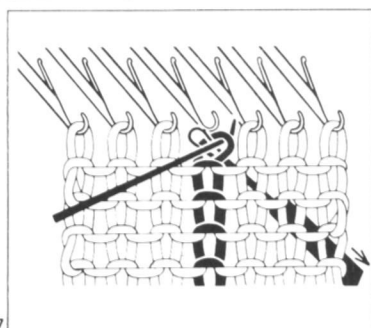
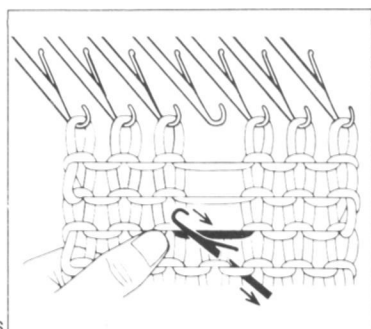
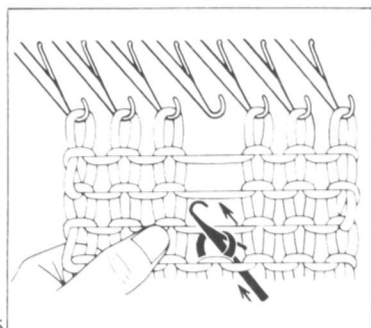

68

How to use the transfer tool

The transfer tools are used to move stitches onto different needles to effect the shaping of the garment, and also to form lacy patterns. Before transferring the stitches you should open the latches of the needles to be used.

(1) Hold the one eyed transfer tool parallel with the needles. Place the eye into the hook of the needle. (See Fig. 69).

(2) With the transfer tool, bring the needle forward. The stitch in the hook of the needle will slide behind the latch and onto the stem of the needle. (See Fig. 70).

(3) Without releasing the transfer tool, push the needle all the way back until the stitch is transferred onto the transfer tool (See Fig. 71).

(4) Raise the transfer tool with the stitch on it and transfer it to the adjacent needle, right or left as desired. (See Fig. 72).

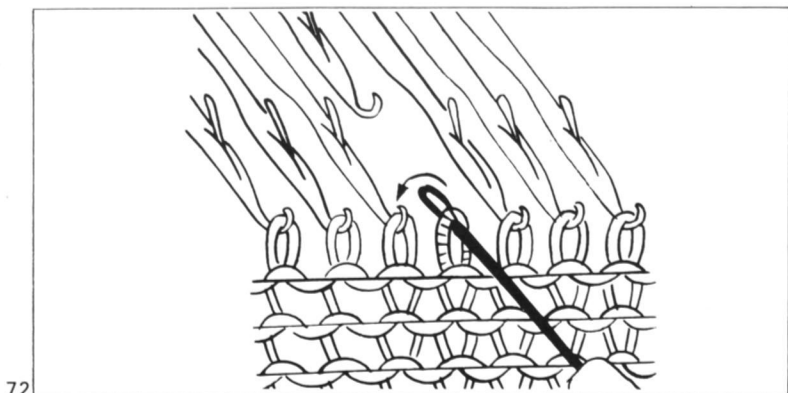
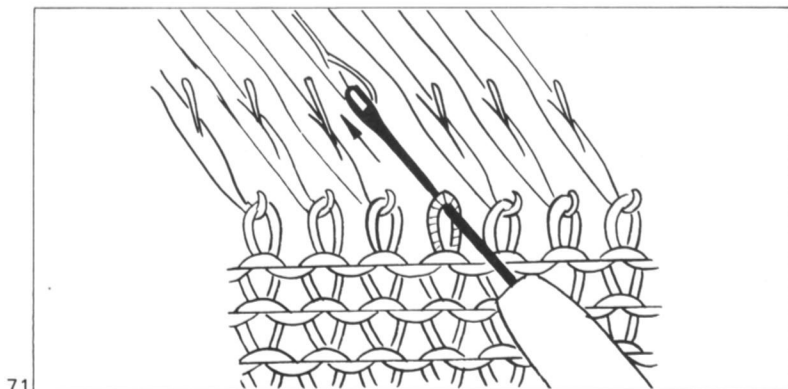
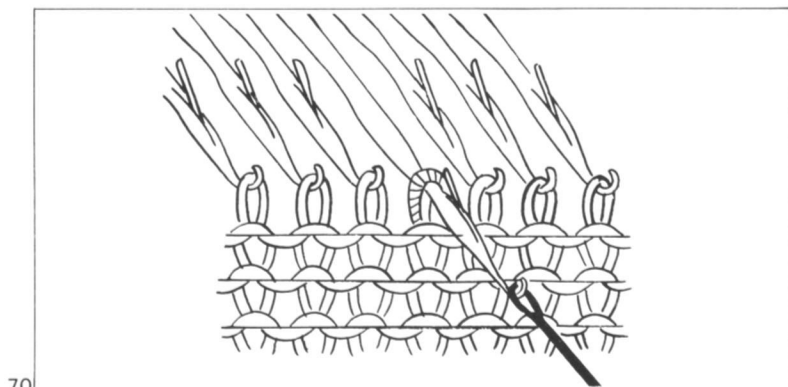
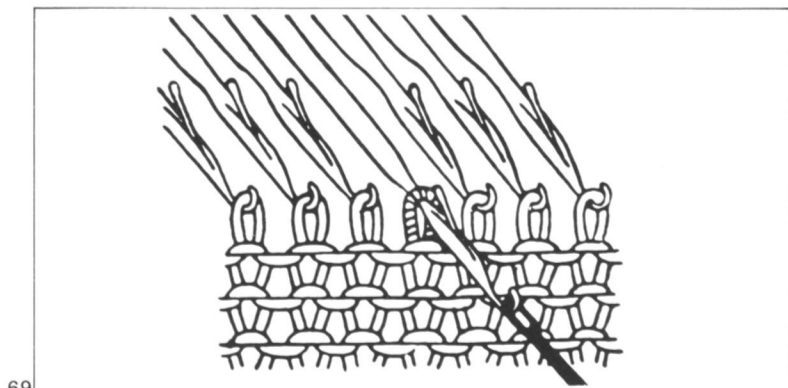

Increasing stitches

28

ONE STITCH AT EITHER EDGE

A. SIMPLE METHOD. Simply bring into working position B one needle from Position A, on the side nearest the carriage. The empty needle will pick up the yarn on the next row.

B. FULL FASHIONED METHOD. (1) Using the two needle transfer tool, move the stitches out by one needle so that the third needle from the end becomes empty.

(2) To fill in the empty needle pick up the purl side of either adjacent stitch on the lower row. (See Fig. 74).

SEVERAL STITCHES AT EITHER EDGE

(1) Push the needles to be increased, to Position E on the same side as the carriage.

(2) Loosely wind the yarn around the stems of each needle, going around the needles from below.

(See Fig. 75).

(3) Set the H.C.L. to Position 3.

(4) Knit across one row.

To ensure perfect knitting on the increased stitches, raise these needles to Position E before knitting across for the next 2 or 3 rows.

INCREASING ONE STITCH IN THE CENTRE ROW

(1) Determine the position where you want to increase one stitch.

(2) Use the 3 needle transfer tool, starting from either end, transfer all the stitches outward in either direction until the required needle is free. (See Fig. 76).

(3) Pick up the adjacent lower half stitch onto the empty needle. (See Fig. 77).

INCREASING SEVERAL STITCHES IN THE ROW

The afore mentioned method can be used working from the centre outwards, or you can transfer the knitting from the knitter to a knitting needle and then return the stitches. Before the knitting is transferred back from the knitting needles to the knitter, determine the number of stitches to be increased and space the replaced stitches so that there will be an equal number of stitches transferred between each extra needle (leaving empty needles where extra stitches are required). Raise the neighbouring lower half stitches to the empty needles. (See Fig. 77).

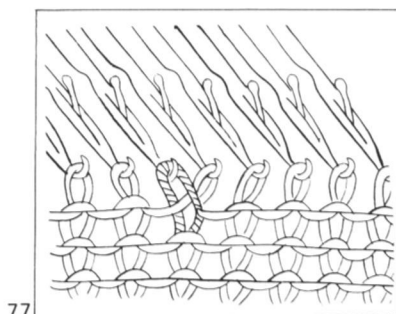
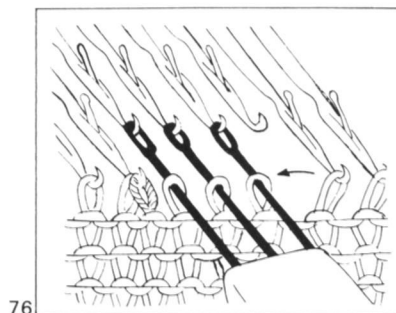
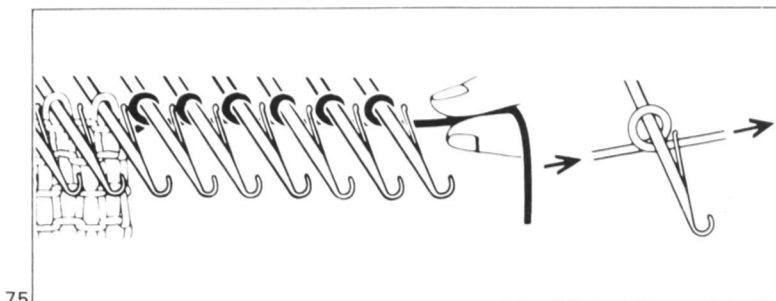
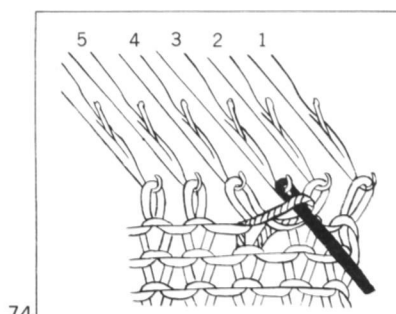
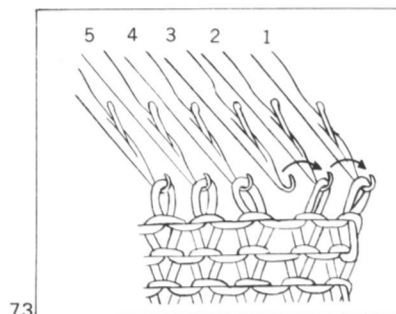

- (1) Slide a hand knitting needle into the first stitch from behind the knitting. With your left hand hold the knitting close to the knitter. With your finger, bring the needle forward so that the stitch in the hook of the needle slide onto the stem of the needle, behind the latch.
- (2) Push the needle all the way back so that the stitch slips all over the closed hook of the needle onto the knitting needle.
- (3) Slide the knitting needle into the next stitch and repeat until all the stitches are off the needles on the needle bed.

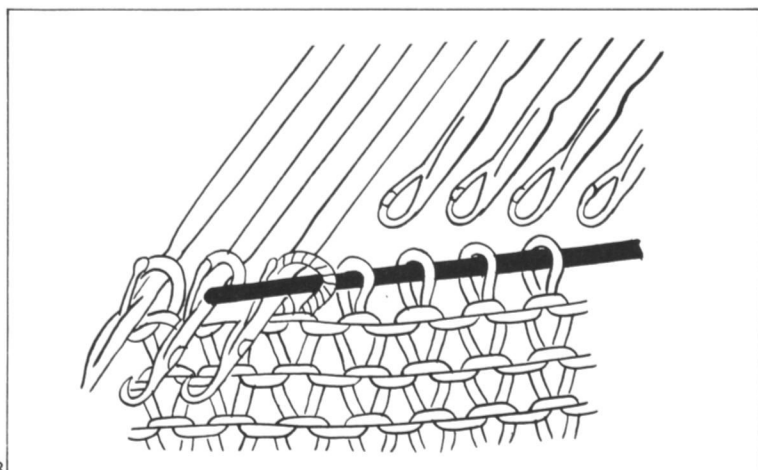

TRANSFERRING OFF THE HAND KNITTING NEEDLE ONTO THE KNITTER

A. USING THE TRANSFER TOOL.

- (1) Open the needle latches.
- (2) Hold the fabric in your left hand with the desired side facing you, the hand knitting needle being in line with the needles.
- (3) Pass the transfer tool through the stitch on the knitting needle from the front. (See Fig. 79).
- (4) Transfer the stitch from the transfer tool onto the hook of machine needles. Push the needle with the transferred stitches back as far as they will go.

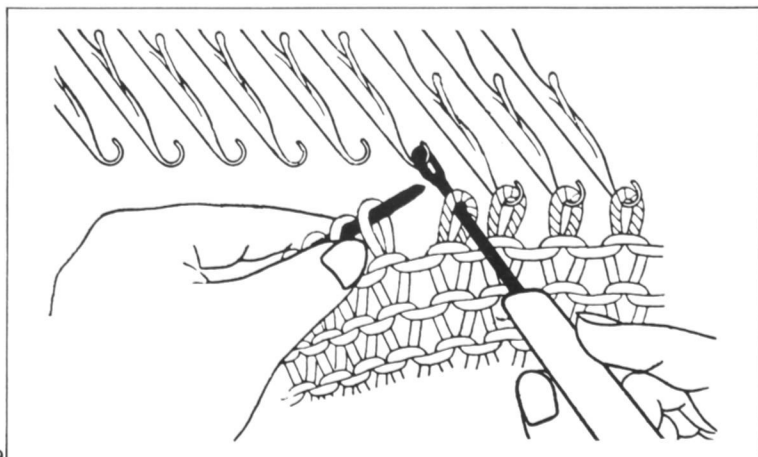

B. ALTERNATE METHOD

- (1) Bring the needles forward to Position 'D', and open the latches.
- (2) Begin from the left side.
- (3) Transfer the stitches from the hand knitting needle onto the open hooks of the machine needles. (See Fig. 80).

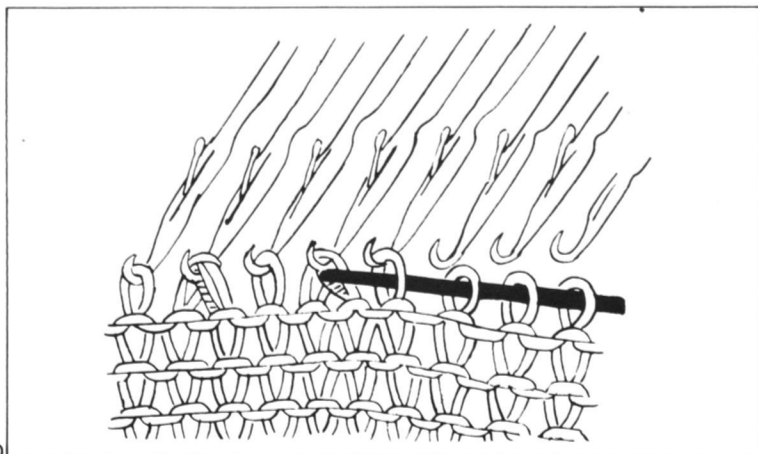

Decreasing stitches

30

ONE STITCH AT EITHER EDGE

A. SIMPLE METHOD.

Using the single transfer tool, transfer the end stitch onto the second needle (See Fig. 81), and push empty needle back to Position 'A'.

B. FULLY FASHIONED DECREASING.

With the single needle transfer tool, transfer the end stitch to the second needle and the 2nd stitch to 3rd needle, together. Push the empty needle out of action.

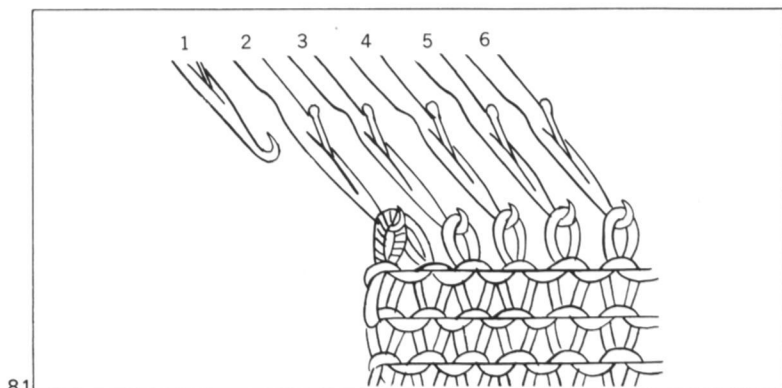

DECREASING ONE STITCH IN THE CENTER OF ROW

(1) Use the single transfer tool and transfer a center stitch to adjacent needle. (See Fig. 82).
(2) Using the 3 needle transfer tool, shift all stitches in until all needles 'in action' have stitches on them, and place the outer empty needles out of action. (See Fig. 83).

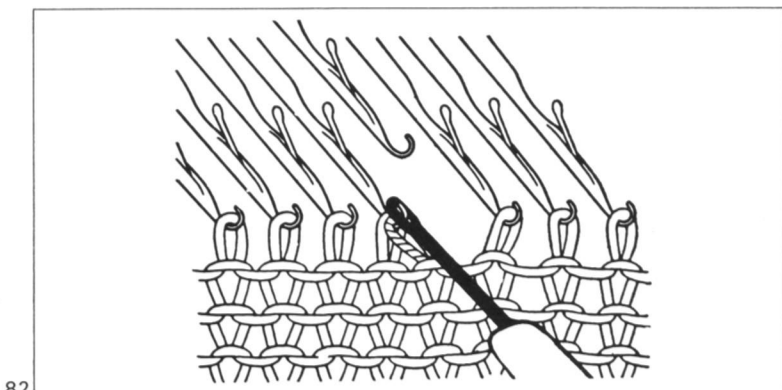

DECREASING SEVERAL STITCHES IN A ROW

(1) Transfer the knitting to a hand knitting needle : (See Fig. 78).

(2) Before returning the knitting from the knitting needle back to the knitter, calculate the proportional reduction in the number of stitches.

For example, to decrease one stitch in every three, hang the 2nd and 3rd stitches both onto one needle. (See Fig. 84).

(3) The number of needles with double stitches represents the number of stitches decreased.

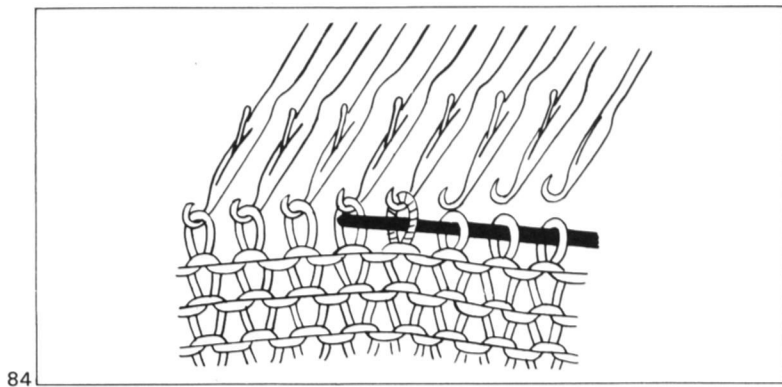
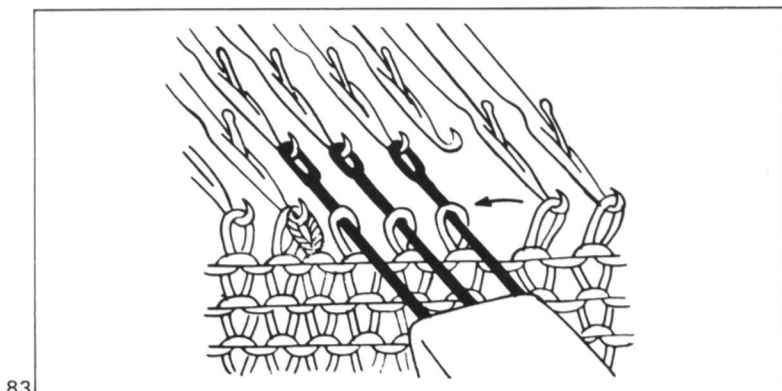

METHOD A

(1) On the same side as the carriage, transfer the end stitch to the 2nd needle.
(See Fig. 85).

(See Fig. 85).

(2) Bring forward the needle with the two stitches so that the stitches fall behind the needle latch. (See Fig. 86).

(3) Place the yarn in the needle hook, in front of the latch and push the needle back manually to form a single stitch. (See Fig. 87).

(See Fig. 87).

(4) Repeat this process for each stitch. Take care not to make the stitches too tight.

After practicing this, you may find it easier to transfer the stitch you have formed by hand, without using the transfer tool.

This method can be used for binding off any number of stitches at neck, armhole, shoulder or pocket edges.

(1) Knit the last row on a much looser tension than the rest of the garment.

(2) Start on the side opposite the carriage.

(3) Hold the latch tool upright, so latch remains open.

(4) Insert the latch hook into the first 2 stitches and remove them from the needles. Let the first stitch slide past the latch.

(4) Pull the second stitch through the first—this leaves one loop in the hook of your latch tool. Continue to bind off one stitch at a time, and seal the last stitch with a slip knot. (See Figs. 89 and 90).

No mention is made in these instructions of decreasing at the centre of the neck or of shaping at the armholes. Whilst following the steps below, the decreasing and shaping must be carried out according to the instructions in the knitting pattern, or according to the measurements of the garment. Remember to put all empty needles back to Position 'A' after transferring and before continuing to knit.

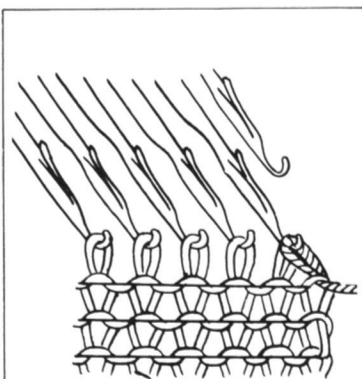

85

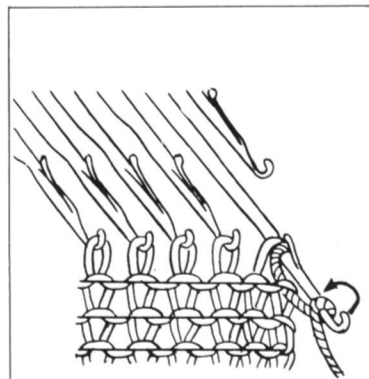

86

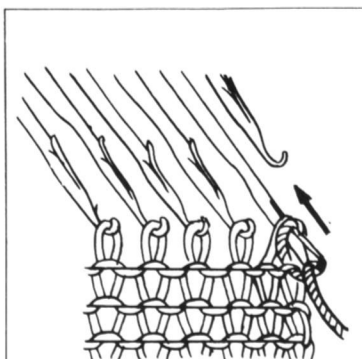

87

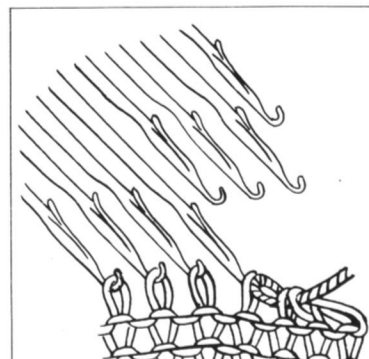

88

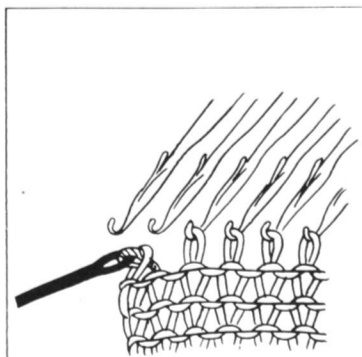

89

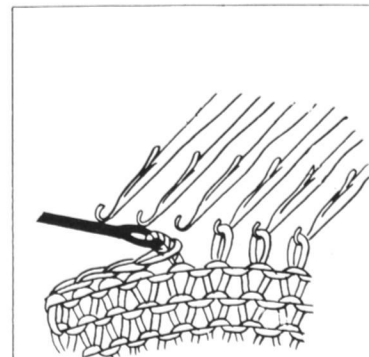

90

Button-holes small

Button-holes medium

32

Small

- (1) Open the latches of two needles where the buttonhole is to be.
- (2) Using the one eyed transfer tool, move the stitches on the right over to the left.
- (3) Bring back the butt of the empty needle to Position B, and continue to knit.

Medium

- (1) OPEN THE LATCHES OF A GROUP OF FOUR NEEDLES.

(2) Transfer the inner two stitches to the adjacent outer needles (See Fig. 91).

(3) Return the two empty needles to Position B and knit one row (See Fig. 92).

(4) After this row the two center needles will only have loops (See Fig. 93).

To ensure that these needles knit on the next few rows, bring them both forward to Position E (for next 2 rows), making sure that the loops fall behind the latches.

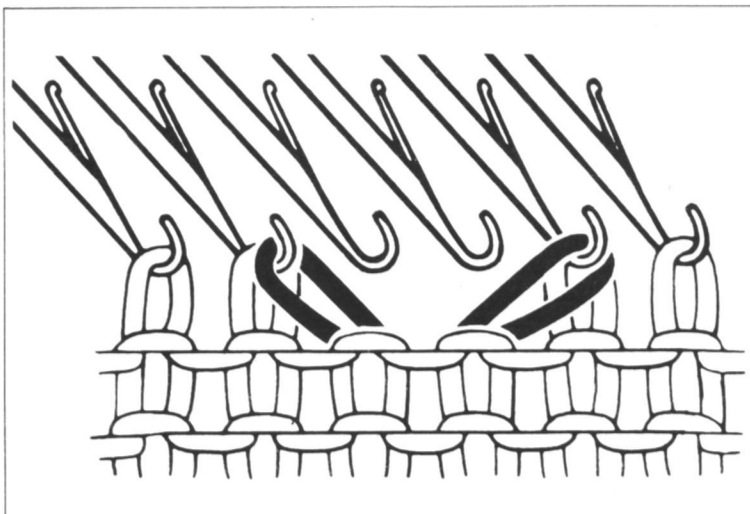

91

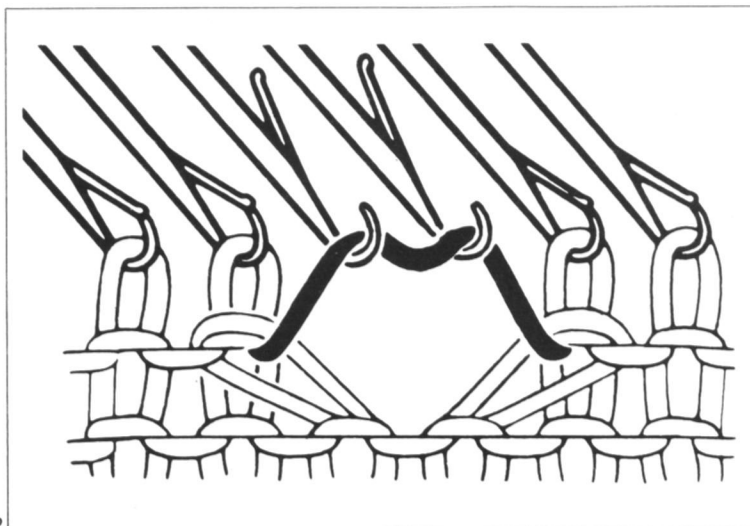

92

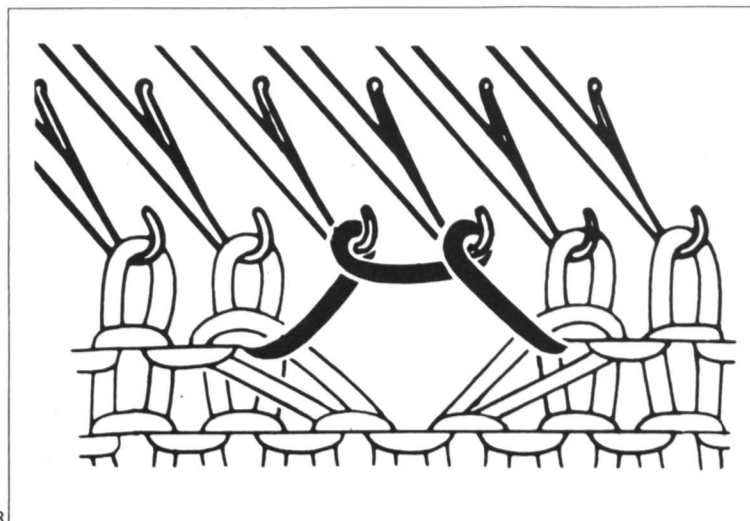

93

(1) Determine the position of the buttonhole. Purl the stitch adjacent to where you want the buttonhole to start.

(2) Catch the purled half stitch and bring it forward onto the latch hook (See Fig. 94). With this as your first stitch, crochet through the next adjacent stitches of the buttonhole—thus casting off (See Fig. 95).

(3) Transfer the stitch off the latch hook, on to the next adjacent needle (See Fig. 95).

(4) Knit one row (H.C.L. on 3). The wool will loop over the empty needles (See Fig. 96).

(5) Starting from the end where the bottom part was sealed off—wind the wool around each needle individually. If there is any left over (this will depend on the tension you are using) then wind an extra loop around each adjacent needle (See Fig. 97). Do not wind too tight.

(6) Raise the needles with the wound loops and a few adjacent needles on either side to Position E. Make sure the loops fall behind the latches. Continue to raise these needle (if it does not interfere with the pattern) for the next two or three rows of knitting.

ALTERNATIVE METHOD FOR LARGE BUTTON-HOLES

Using a contrast color wool, cast off the number of stitches needed for the buttonhole. Continue knitting (raising these needles to Position E for the next few rows) until the garment is completed. The buttonhole can be finished by stitching, and the contrast wool taken out.

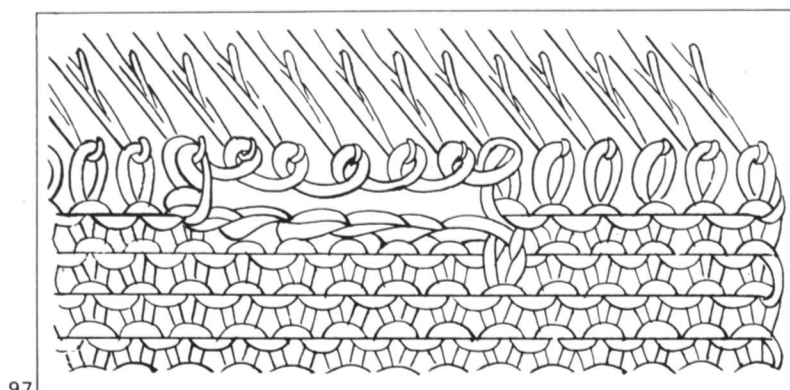
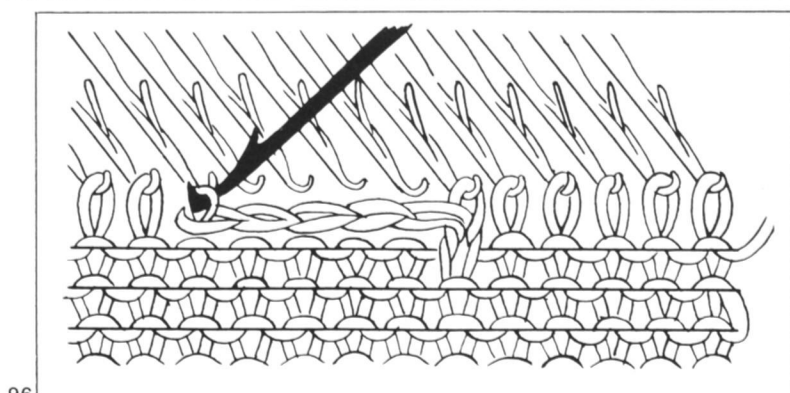
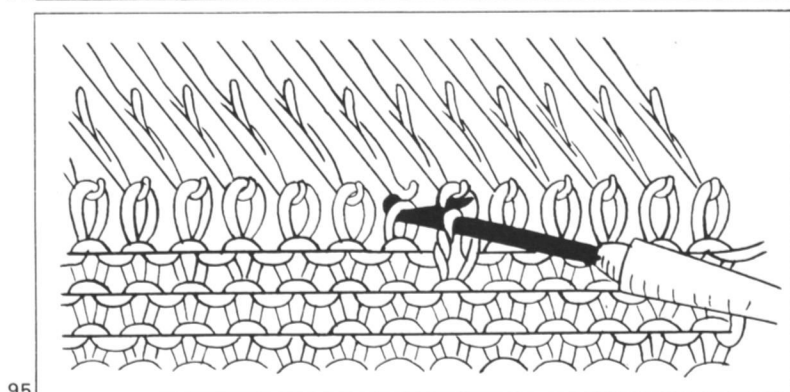
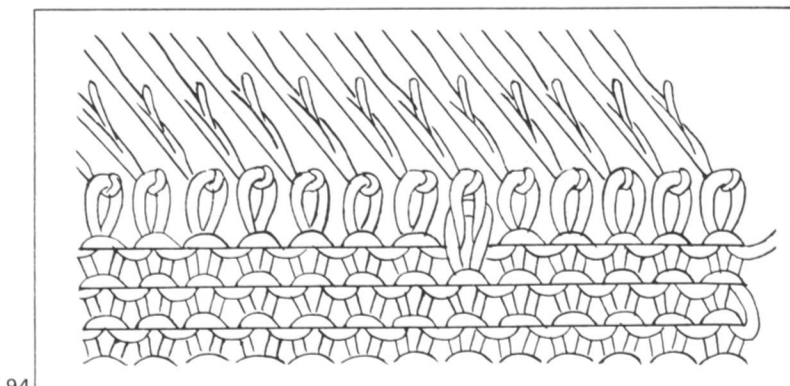

97

Making a vertical buttonhole

How to knit a pocket

34

Making a Vertical Button Hole

Knit up to the row where the buttonhole starts. If the carriage is on the right side of the needle bed, knit the right side of the buttonhole first.

(1) Set the H.C.L. to Position 2.

(2) Determine where the buttonhole is to be and bring forward to Position 'E' all the needles on the left of the buttonhole.

(3) Knit 6 rows. (If a larger buttonhole is desired, knit as many rows as is necessary.)

(4) Break the yarn; take the carriage off the needle bed and replace it on the other side.

(5) Return the needles that were in position 'E' to Position 'C' and bring forward the needles on the right to Position 'E'.

(6) Knit the left side of the buttonhole, the same number of rows as for the right side. After you have completed the same number of rows, set the H.C.L. to Position 3 and continue to knit.

Instructions are given for the carriage on the right side of the bed.

How to knit a Pocket

(1) Determine the position of the pocket, and bring forward to Position 'E' all the needles on the left of the pocket.

(2) Set the H.C.L. to Position 1.

(3) Knit one row and bring forward to Position 'E' all the needles on the right of the pocket.

(4) Knit one row again.

(5) The carriage is now on the right and you can knit the amount of rows required for the pocket. Move the carriage across slowly with one hand and put the other hand behind the fabric and pull the knitting down slightly. Finish the complete pocket with the carriage on the right.

(6) Push the needles on the left back to Position 'C' taking care not to let the stitches fall over the latches.

(7) Knit one row, and set the H.C.L. to Position 3.

(8) Continue knitting the garment.

The pocket can now be pulled through to the side of the fabric facing you. To complete the pocket sew up (or weave) the stitches at the sides.

98

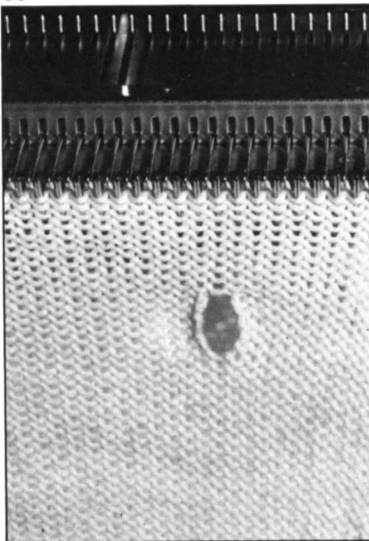

99

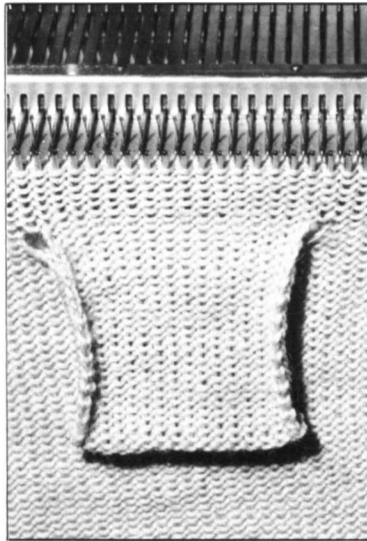

knit the fabric to the row where the 'V' neck commences. The instructions are written to start with the carriage on the right side of the bed. If the carriage is on the left then read LEFT for RIGHT and vice versa.

- (1) Place the H.C.L. on 1.
- (2) Bring forward to Position 'E' all the needles on the left side of the center 'O'. These needles will not knit until the right side is completed. (If you wish you may take them off onto a knitting needle and replace them later).
- (3) Transfer the first stitch on the right of 'O' to the adjacent needle on the right (in Pos. 'B') Return the empty needle to Pos. 'A'.

N.B. FOR FULLY FASHIONED
—transfer both first and second stitches onto the second and third needles, and continue transferring two at a time.

- (4) Knit two rows.
- (5) Continue decreasing one stitch every two rows until you have the required number of stitches left for the shoulder. Bind off these stitches and break the wool.
- (6) Return all needles at left to Pos. 'B' by putting three at a time onto a transfer tool, and slipping the stitches inside the needle hooks (i.e., not behind the latches). Knit this side identical to the other.

N.B. If you are doing a pattern using the H.C.L. then after bringing the needles (for the pattern) forward with the Set Lever—they will have to be returned by hand. To do this just push the needle back to Position 'C', and it will knit together with the other needles in 'B'.

KNITTING THE HEM TO THE 'V' NECK

Bring forward to Position 'B' the number of needles required for HALF the neck and back of garment. Open the latches of all these needles.

Set the carriage and machine dials as for Plain Knitting. With the wrong side of work facing you, and using the one eyed transfer tool, pick up the 1st stitch nearest to the 'V' onto the first needle nearest to the carriage.

Now continue to raise all the stitches from the half 'V' onto the empty needles. (You may prefer to have the hem tighter and therefore raise all the stitches onto $\frac{4}{5}$ the corresponding number of needles. To do this, miss out every 4th stitch and raise every 5th stitch onto every 4th needle).

IF YOU WISH TO DO THE NECKBAND IN ONLY TWO PIECES THEN RAISE HALF THE STITCHES FROM THE BANK OF THE GARMENT ONTO THE NEEDLES AFTER RAISING HALF THE NECK STITCHES.

With the same yarn knit one row across (N.B. All needle butts should be in Position 'B').

YOU CAN NOW KNIT THE HEM

The bottom end of the hem should be mitred (for the V shape), by decreasing at the 'V' end until the hem is halfway through. Now increase in reverse order so that when the hem is completed you have the same number of stitches on—as when started.

REPEAT THE SAME PROCESS FOR THE OTHER SIDE OF THE NECK STARTING AT THE 'V'

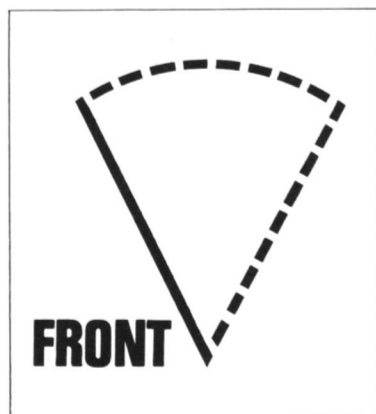

100

Shaping a round neck

Shaping a square neck

36

Round neck

Instruction are given for the carriage on the right side of the needle bed.

(1) Place the H.C.L. on Position 1.

(2) Bring forward to Position 'E' all the needles on the left side of the center 'O'.

(3) The decreasing of the stitches is done by bringing forward to Position 'E', the needles you wish to decrease. Start with the needles in

Position 'B' on the right of 'O' and knit two rows each time you bring needles forward.

(4) Decrease in this manner until you have the required number of stitches left in Pos. 'B' for the shoulder.

(5) Bind off these stitches and break the yarn.

(6) Return the needles on the left back to Position 'B' and repeat as above, from 3 to 5. Remember to leave the same amount of needles for the shoulder. Bind off these stitches.

(7) Place the end stitches of the round neck onto the knitter.

(8) Place the carriage on the left and thread the yarn feeder. H.C.L. on Position 3.

KNITTING THE HEM :

(9) Knit the first half of the hem (approx. 5 rows) on a normal tension for that yarn.

(10) Knit one row on a tension 3 numbers higher. This will ensure that the fold will be flat.

(11) Knit the other half of the hem on the same tension as used in No. 9. (N.B. It must be the same amount of rows as the first half).

(12) Using the transfer tool, raise the stitches from the end of the round neck onto the needles. Take care to raise each stitch onto the corresponding needle to obtain a perfect round effect.

(13) When all the stitches have been raised, bind off the double stitches in the normal way.

N.B. Seal the stitches by hand very loosely, to allow for the neck to fall back into place after removing the knitting from the machine.

Square neck

Cast off the needles in the centre, for the width of the neck, using the same wool as that for the garment. Return needles to Position 'A'.

On the opposite side to the carriage bring forward all the needles to Position 'E'. Set the H.C.L. to 2.

Knit the required number of rows to complete the side nearest the carriage. Cast off and return the needles to Position 'A'.

Set H.C.L. to 3 and knit other half identical to first.

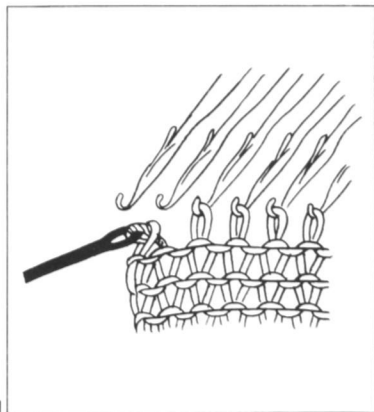

101

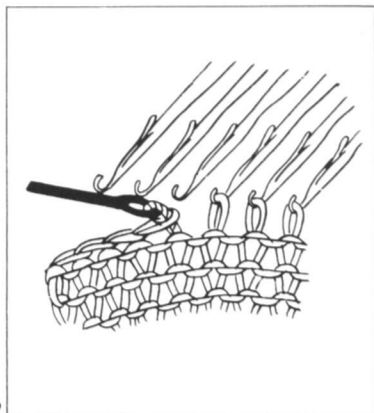

102

SHORT ROW DESIGNING

This method of shaping has endless possibilities and is used most frequently for :

Turning the heel of socks ;
pockets ; horizontal darts ;
circular piece-yokes, skirts and
zig-zag designs.

Set the H.C.L. to Position 2,
then put one or more needles
in Position 'E', so that these
needles stop knitting and hold
the stitches for further use.

TWO COLOR DIAGONAL KNIT (USING SHORT ROW METHOD)

- (1) Start with the carriage at the right and the H.C.L. on Position 2.
- (2) Raise two needles on the left to Position 'E'.
- (3) Knit one row to left and pass the yarn under the stem of the needle in Position 'E' on the right. Knit one row to the right.
- (4) Continue raising two needles and knitting 2 rows as above, until all needles are in Position 'E'.
- (5) Change the yarn ; remove carriage from the right side and place on the left side of knitter. Starting at the left push into Position 'C', two needles at a time, and knit one row to the left and one to the right. (Reversing the previous process until all needles are back in knitting position.)

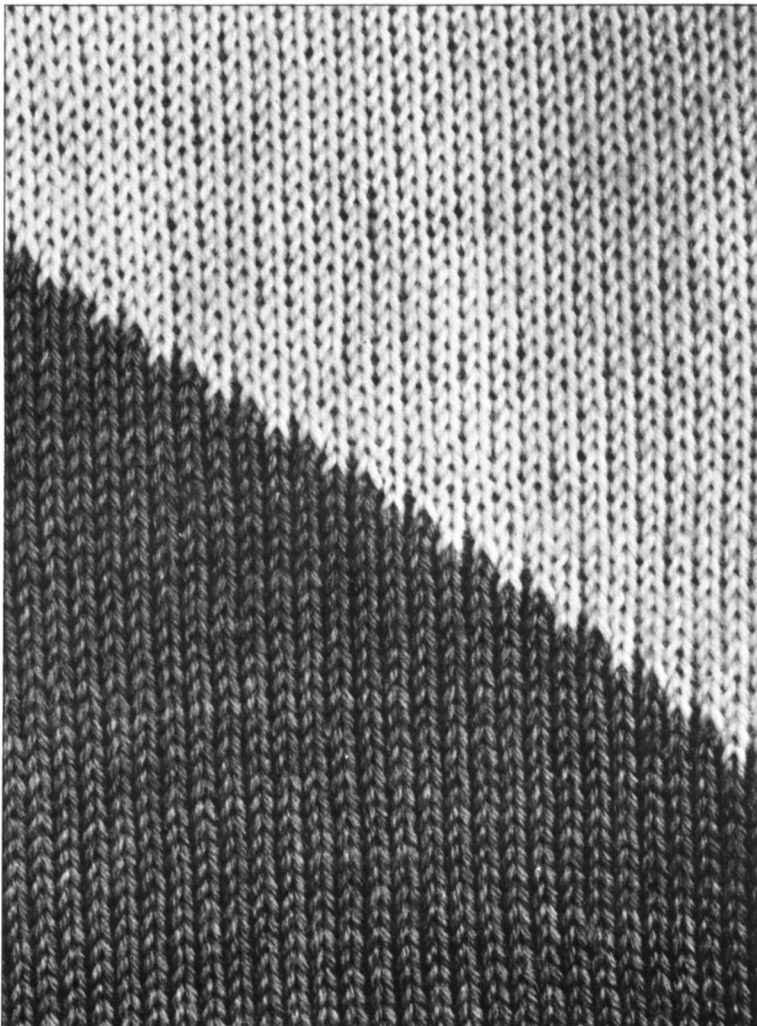
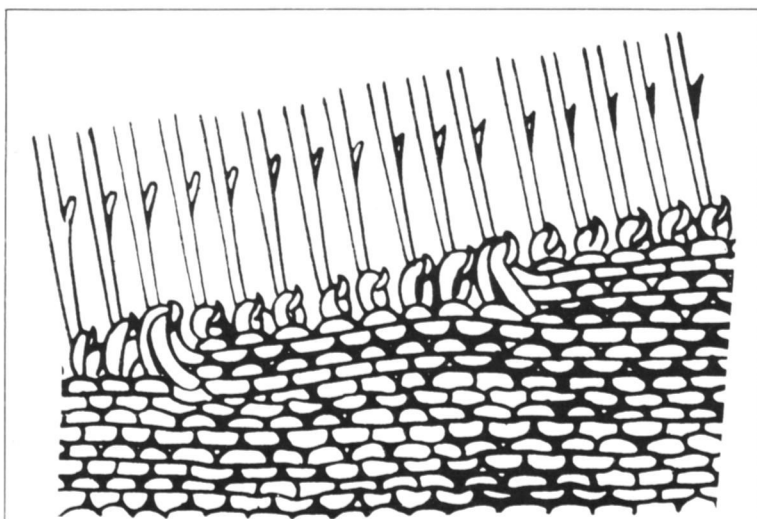

How to use the pattern center

38

Introduction of the Pattern center

As previously explained on page 8, there are six different position, of needles (A, B, C, D I, D II & E).

The pattern center which holds the Pattern card cassette and the operation card is used to select the needles you wish to use (Always in sequence of 2, 3, 4, 6 or 12) and bring them forward into action and also to control the rows up to 36 steps for producing the pattern.

For conveniences sake, ten sets of the preset pattern card cassettes and the operation cards for basic patterns are provided with the machine.

Also, as an additions, the twenty spare pattern card cassettes which are not perforated are included for producing your own original pattern or any other patterns you like.

Please see page 53 and simply follow the instruction "How to use the spare pattern card cassettes and the operation cards".

Once a card cassette and a operation card are set into the pattern center, the pattern can be produced as often as you desire.

CHANGE LEVER (N—MC)

This control has two settings, N and MC.

1. N ; When in this position, the set lever brings selected needles corresponding to the perforations of pattern card cassette to position D I . Use this setting for all patterns except color work.

105

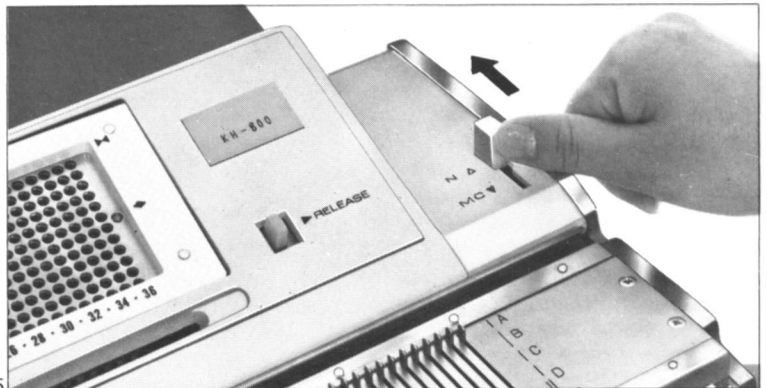

2. MC ; When set on MC, the selected needles corresponding to the non-perforated columns of pattern card cassette are brought forward to D II position by swivelling the set lever. This position is used for Fair-Isle and color patterns (this setting will shift the produced patterns a stitch to the left).

106

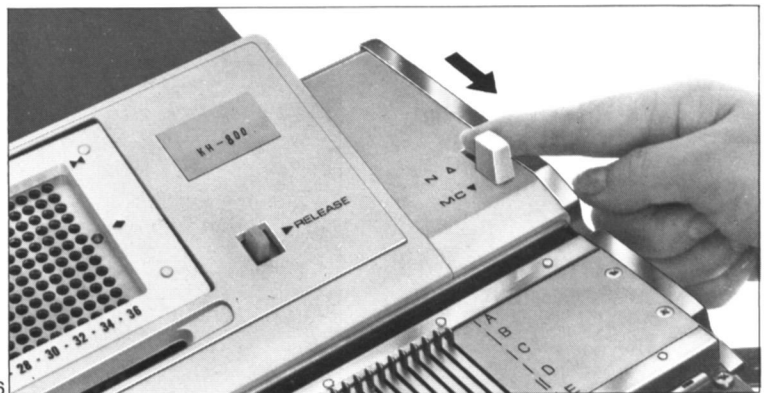

NEEDLE SELECTOR

Each perforation of the pattern card cassette controls each needle group. A combination of perforations made on the vertical column of the pattern card cassette will control the corresponding combination of selected needles for the steps. The needles corresponding to the perforations made on vertical column of pattern card cassette can be selected by swivelling the set lever.

For example, the perforation made on the top of horizontal column (the top of every vertical column) where the mark \bowtie appears will select the needles on the mark \bowtie of needle bed by swivelling the set lever. The second horizontal column will control the needles next to the mark \bowtie of needle bed. Relation between the perforation of pattern card cassette and the needles are shown in this figure. (See Fig. 112).

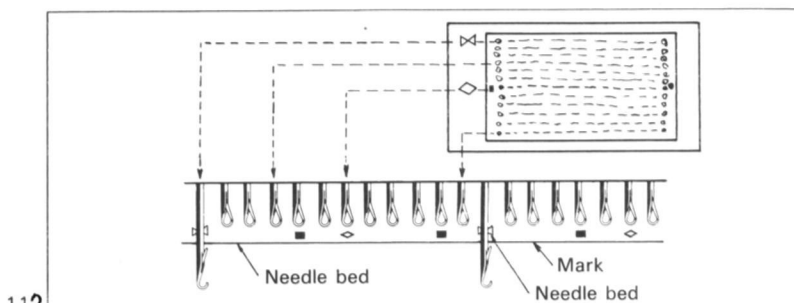

112

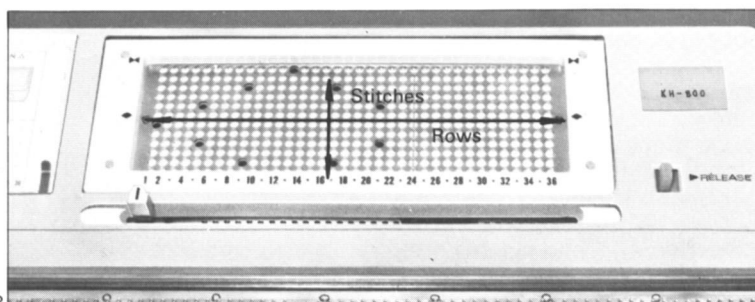

113

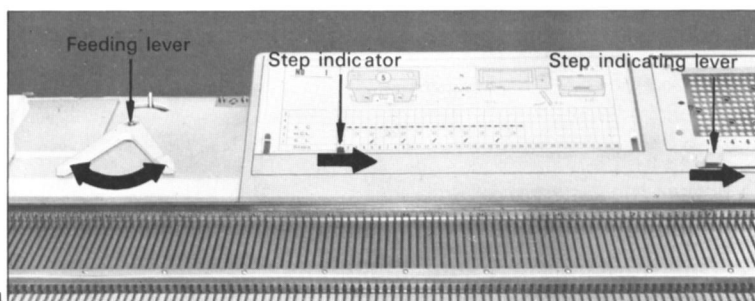

114

STEP INDICATOR

The step indicator is connected to the Step indicating lever and is moved simultaneously whenever the step indicating lever moves. (See Fig. 114).

STEP INDICATING LEVER

Every time it returns automatically to the starting position from the set position of the Pattern repeat regulator, this lever will be at a standstill unless and until you swivel the set lever to repeat producing pattern.

This lever will move one step to the right as feed lever moves by carriage from left to right or from right to left.

This lever will go back one step to left by pressing it down as far as it will go then releasing. (Fig. 116).

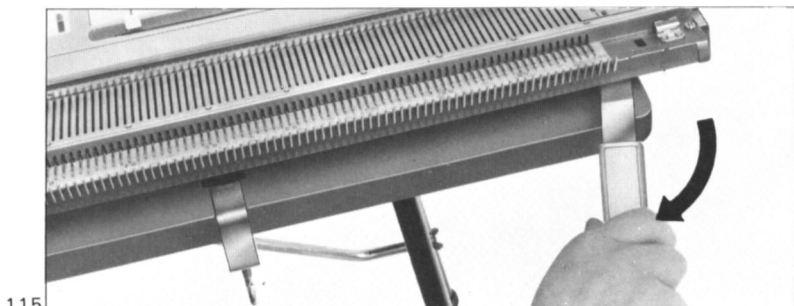

115

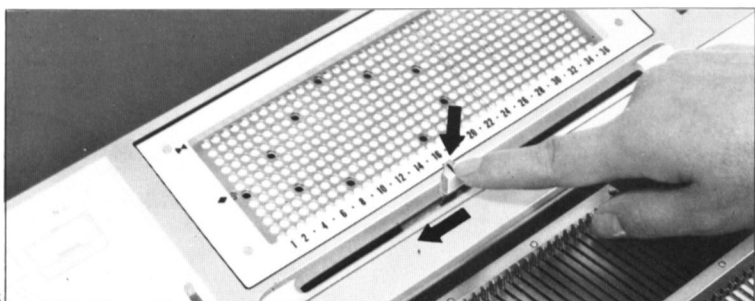

116

When pushing this lever by finger to right it will slide to right.

AUTOMATIC PATTERN REPEAT REGULATOR

This regulator can be set to any position you wish and turn the step indicating lever back to it's starting position when it reaches to the set position of this regulator.

When pushing the step indicating lever further to right beyond this regulator, this will move to the right together with the step indicating lever. (Fig. 118).

117

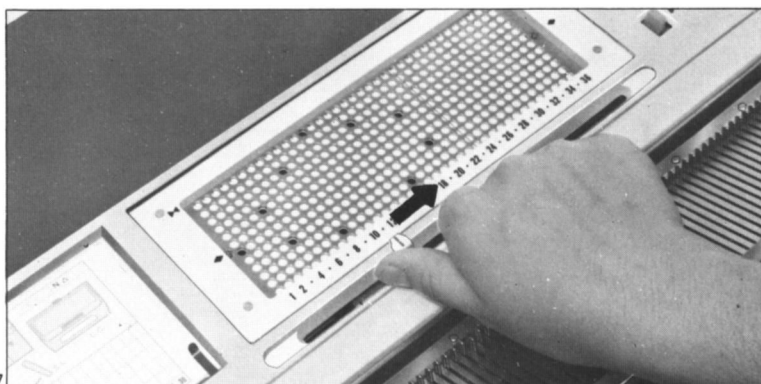

118

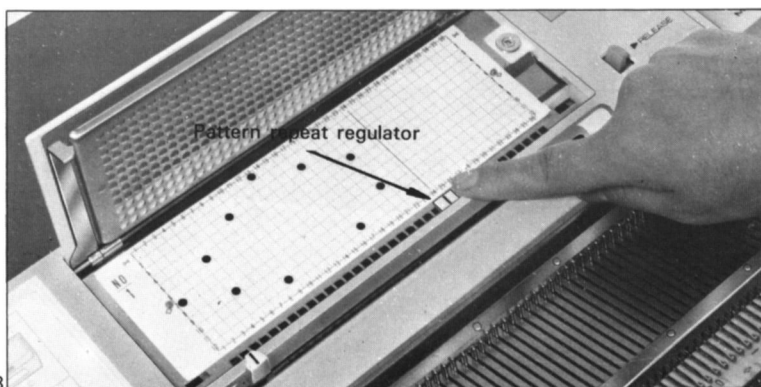

Explanation of the Operation Card and the Pattern Card Cassette

The Operation card is read from Left to Right and each step (normally a row) should be followed from the bottom upwards.

119

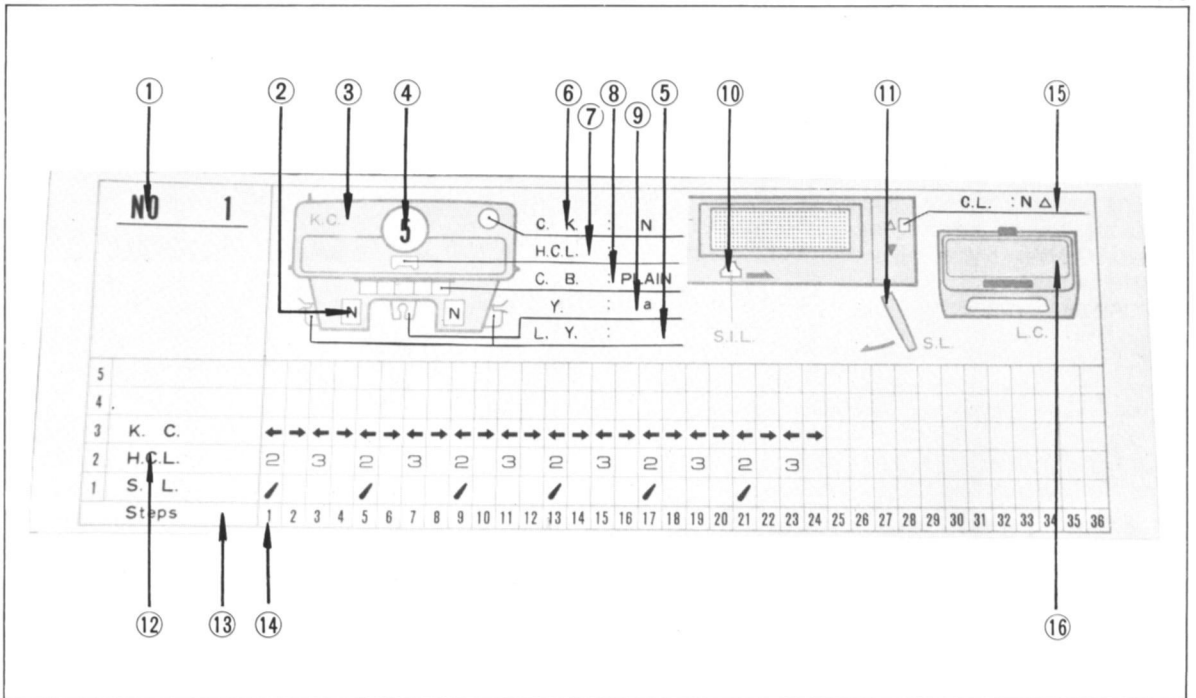

1. Number of Pattern : Shows the number of pattern.
2. W.B. (Weaving Buttons) : The position of the Weaving buttons are shown.
3. K.C. (Knitter Carriage) : Move the carriage according to the direction of the arrow. Before step 1 the carriage should be on the right side.
4. Tension dial : The number shown here is the tension on the carriage dial that this pattern was knitted in. The tension differs for each type of wool, and therefore this number can only be used as a guide.
5. L.Y. (Laying-in Yarn) : The color (b, c, . . .) of the yarn used for Weaving or Fair Isle knitting.
6. C.K. (Change Knob) : The position for this on the carriage is shown here.
7. H.C.L. (Holding Cam Lever) : This shows the position for this lever on the carriage.
8. C.B. (Carriage Buttons) : These are 5 buttons on the carriage. The set position for these buttons is indicated.
9. Y. (Yarn Feeder) : This shows the main color (a) of the yarn in this feeder.
10. S.I.L. (Step Indicating Lever) : When mark **▲** is shown in the relative column for each step, it means to push this lever one step to right by finger.
11. S.L. (Set Lever) : The mark **/** in the columns indicates to swivel the set lever.
12. Shows the operations to be varied in the source of knitting.
13. Step : The required operation for each step or movement of the carriage is shown in the vertical column of the step. According to this operation card, the pattern up to 36 step can be knitted as a maximum.
14. Necessary operation for each step will be indicated.
15. C.L. (Change Lever) : This shows the position for this lever on the needle bed.
16. L.C. (Lace Carriage) : Move this carriage according to the direction of the arrow.

Example of Simple Pull-up stitch Pattern (No. 1)

Preparing to knit

1. Take No. 1 operation card and pattern card cassette then set them into the pattern center.
2. Set the automatic pattern repeat regulator to the last step (24th column) of pattern.
3. Knit few rows of plain knitting and place the carriage to the right.

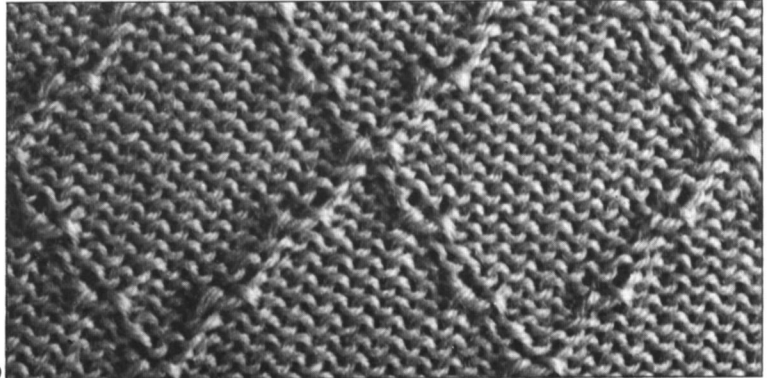

4. Based on the instruction of operation card, set the machine as follows :

- Tension dial (T.D.) 5
- Yarn in feeder (Y.) Main yarn (a)
- Carriage button (C.B.) PLAIN
- Change knob (C.K.) N
- Weaving button (W.B.) N
- Change lever (C.L.) N (Δ)

Knitting

Always watch the step indicator.

Step 1.

- 1) Swivel the set lever.
- 2) Set the H.C.L. on position 2.
- 3) Move the carriage across the needle bed to left.

Step 2.

- 1) Do not swivel the set lever.
- 2) The H.C.L. remain unchanged on 2.
- 3) Move the carriage to right.

Step 3.

- 1) Do not swivel the set lever.
- 2) Change the H.C.L. to 3.
- 3) Move the carriage to left.

Step 4.

- 1) Do not swivel the set lever.
- 2) The H.C.L. remain unchanged on 3.
- 3) Move the carriage to right.

Repeat step 1 to 4 until 24th step. When finishing 24th step, the step indicating lever and the step indicator will return to the starting position. A pattern is completed and then same pattern will be repeated.

NO	1																																				
5																																					
4																																					
3	K. C.	2	3	2	3	2	3	2	3	2	3	2	3	2	3	2	3	2	3	2	3	2	3	2	3												
2	H.C.L.	2	3	2	3	2	3	2	3	2	3	2	3	2	3	2	3	2	3	2	3	2	3	2	3												
1	S. L.	1	2	3	2	3	2	3	2	3	2	3	2	3	2	3	2	3	2	3	2	3	2	3	2	3											
	Steps	1	2	3	4	5	6	7	8	9	10	11	12	13	14	15	16	17	18	19	20	21	22	23	24	25	26	27	28	29	30	31	32	33	34	35	36

NO	1																																				
36																																					
35																																					
34																																					
33																																					
32																																					
31																																					
30																																					
29																																					
28																																					
27																																					
26																																					
25																																					
24																																					
23																																					
22																																					
21																																					
20																																					
19																																					
18																																					
17																																					
16																																					
15																																					
14																																					
13																																					
12																																					
11																																					
10																																					
9																																					
8																																					
7																																					
6																																					
5																																					
4																																					
3																																					
2																																					
1																																					

HERE ARE A FEW
MORE EXAMPLES OF
ONE COLOR
PATTERN STITCHES

TUCK stitch pattern
(No. 2)

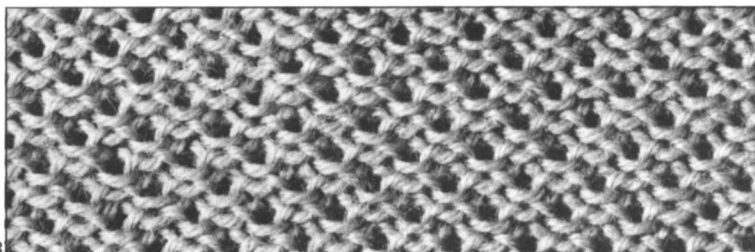

123

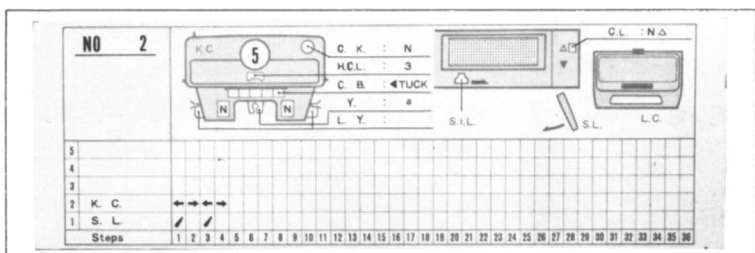

124

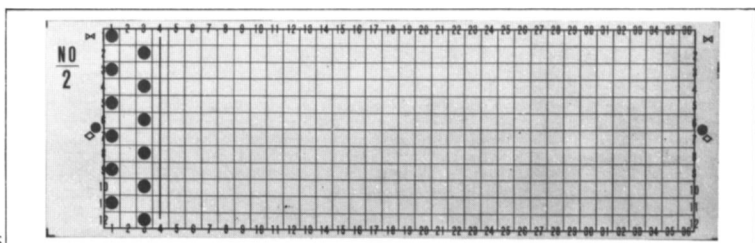

125

Pull-up TUCK stitch
pattern (No. 3)

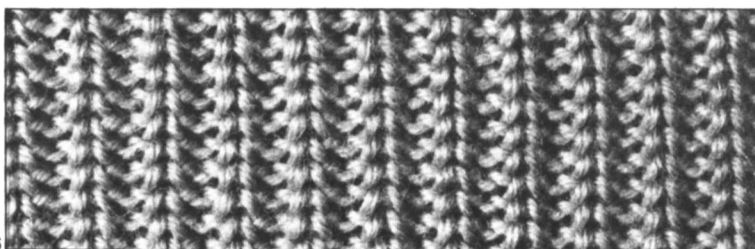

126

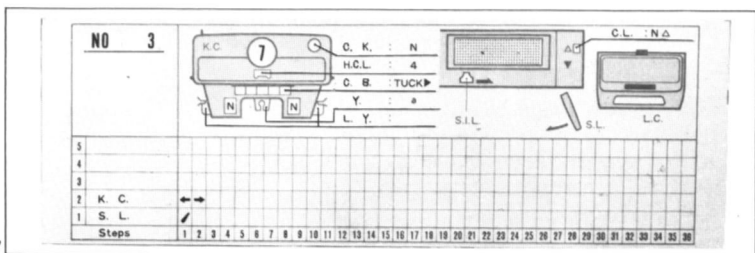

127

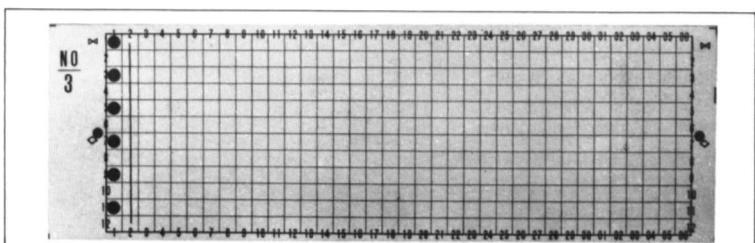

128

**Fair Isle pattern
(No. 5)**

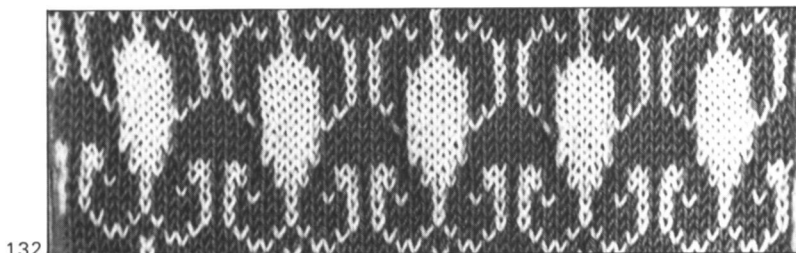

132

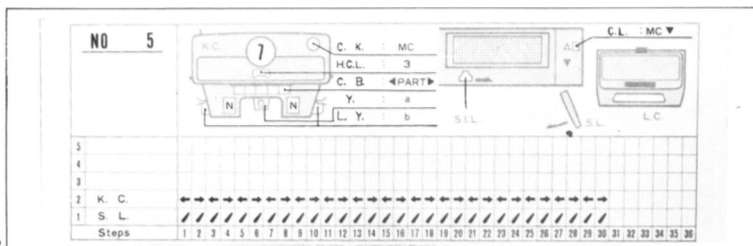

133

**Skip stitch pattern
(No. 6)**

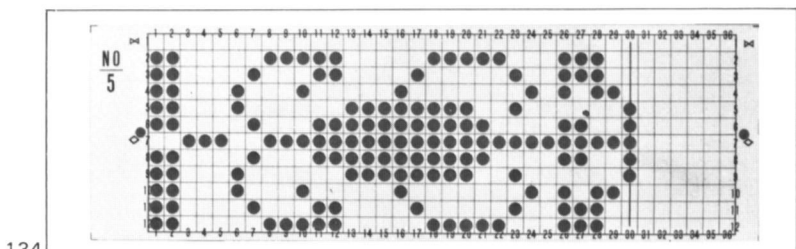

134

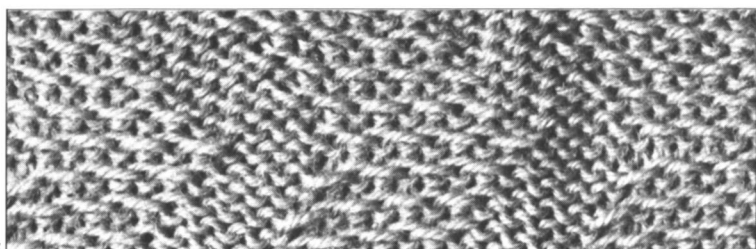

135

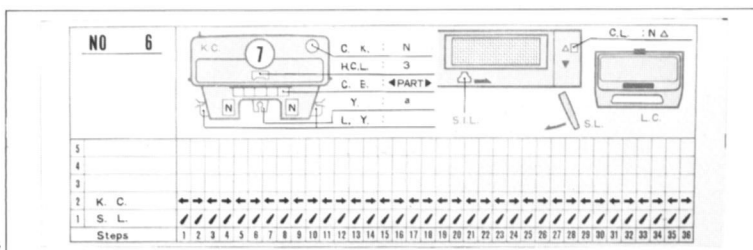

136

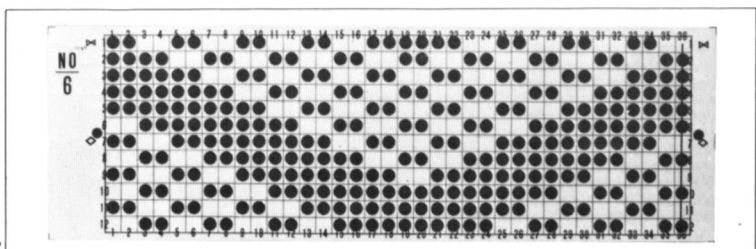

137

How to weave on your machine

PRINCIPLE OF WEAVING

The weaving (or laying-in) apparatus is built into the knitting carriage. The weaving is done at the same time as knitting a row.

The best woven material effect is obtained when the wool you are using to knit is very thin (2 or 3 Ply) and the weaving wool is thick (Double or Triple Knit).

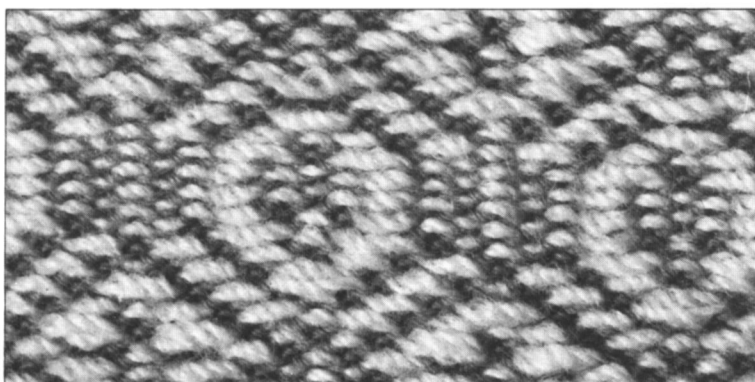

Preparing to knit

1. Place No. 7 pattern card cassette and operation card on pattern center.
2. Set the automatic pattern repeat regulator on 16th step of pattern.
3. Set the machine as follows, according to the instruction of operation card.
Tension dial (T.D.) 6
Yarn in feeder (Y.) Main yarn
Carriage button (C.B.) PLAIN
Holding cam Lever (H.C.L.) on 3
Weaving button (W.B.) both on T
Change knob (C.K.) on T
Change lever (C.L.) on N
4. Set the step indicating lever on the starting position.

138

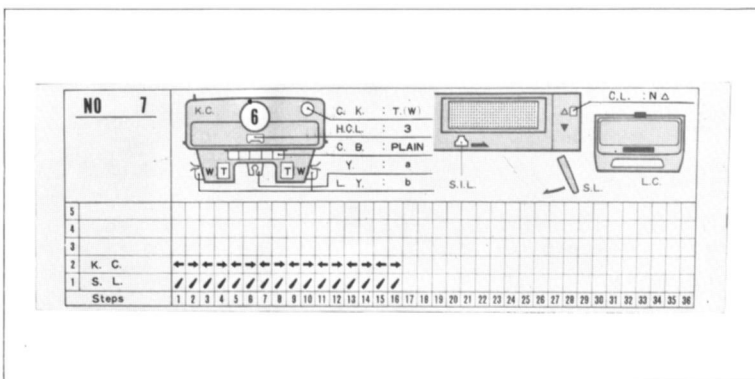

139

Knitting

Always watch the step indicator.
Step 1.

- 1) Swivel the set lever.
- 2) Put the laying-in yarn (Weaving yarn) into the yarn guide left and move the carriage to left.
- 3) Change the laying-in yarn into the yarn guide right. Then move the carriage to right.
- 4) Repeat the above steps to 16th step of black line of pattern. One cycle of pattern will be completed. You can use the Yarn tension unit and Laying-in yarn guides for Weaving yarn (same as the method of Fair-Isle pattern knitting). However, if the weaving yarn is too thick, lay across the weaving yarn on the hook of the selected needles by hand.

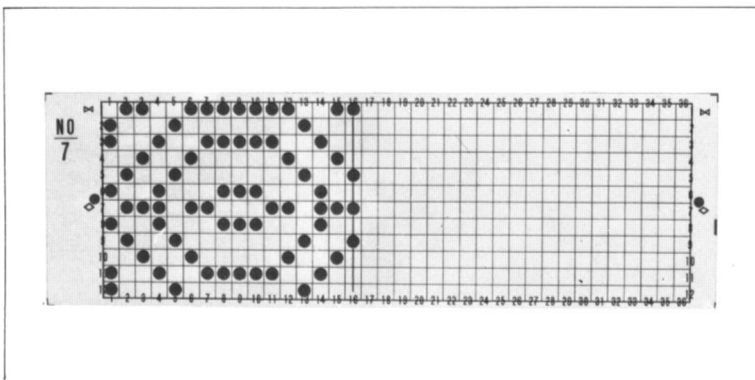

140

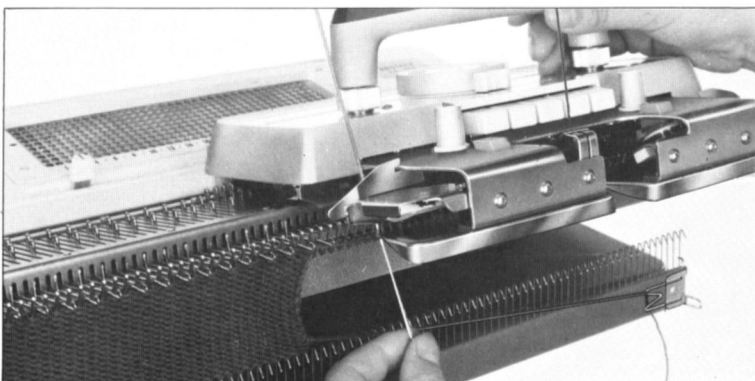

141

Here is another weaving pattern to practice.
 Main yarn—3 ply yarn.
 Weaving yarn—4 ply yarn.

*No. 8 pattern card cassette can be applied to Full Tucking Pattern. Depress both TUCK cam buttons and swivel the set lever every row. Also this card can be applied to any pattern with 1 × 1 needle combination.

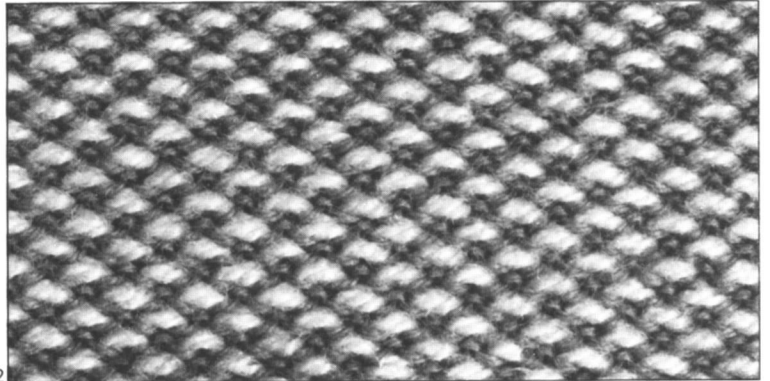

142

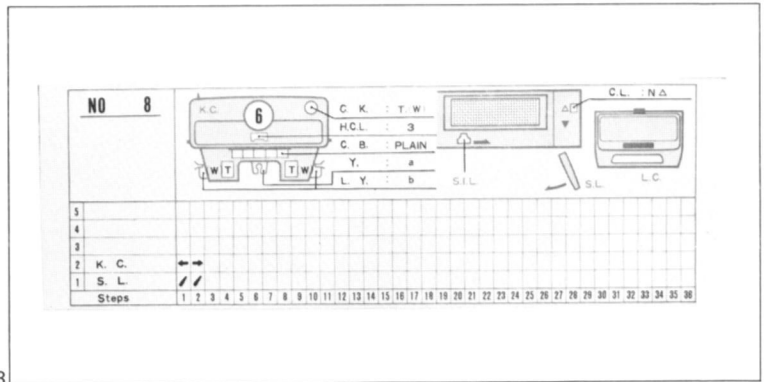

143

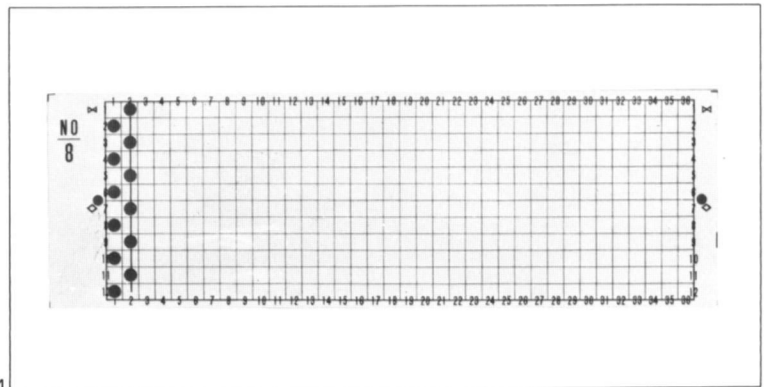

144

Preparing the "L" carriage

Remove the Extension rails from the carrying case. (See Fig. 145).

Insert the long leg of the Extension rail into the hole at the edge of the machine (A) and the short leg into the fastener (B) on the lower needle bed. (Put the Extension rails to both sides of the machine). (See Fig. 146).

Fasten the second handle onto the "L" carriage. (See Fig. 147).

If you are using a 2 ply wool or lace cotton, fit the wool wax onto the front yarn guide. (See Fig. 148).

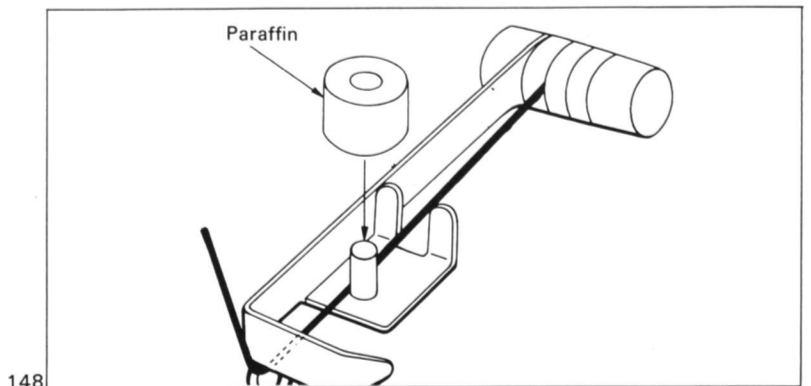
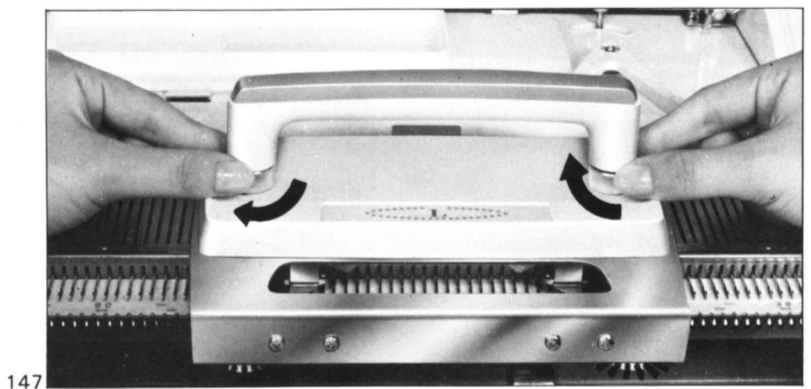
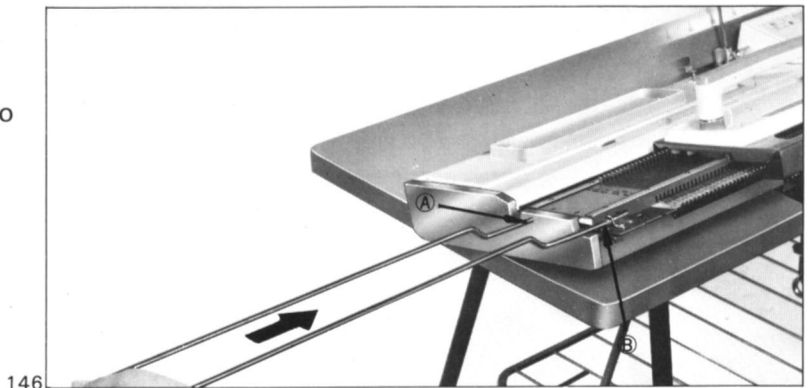
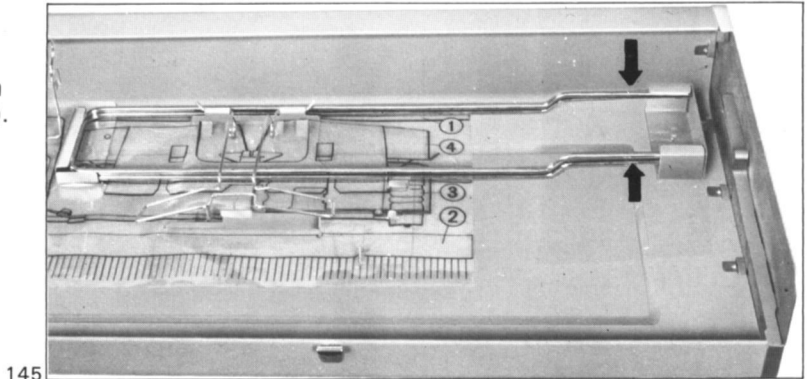

Knit several rows in plain stitch, and hang the claw weights onto the cast on comb. (See Fig 149).

IT IS IMPORTANT THEREFORE THAT NO TWO (OR MORE) ADJACENT NEEDLES ARE BROUGHT FORWARD TOGETHER. (See Fig. 150).

In the event that an end needle is brought forward (on the side away from the carriage) it should be pushed back by hand to Position B. You can do this without fear of the stitch dropping. (See Fig. 151).

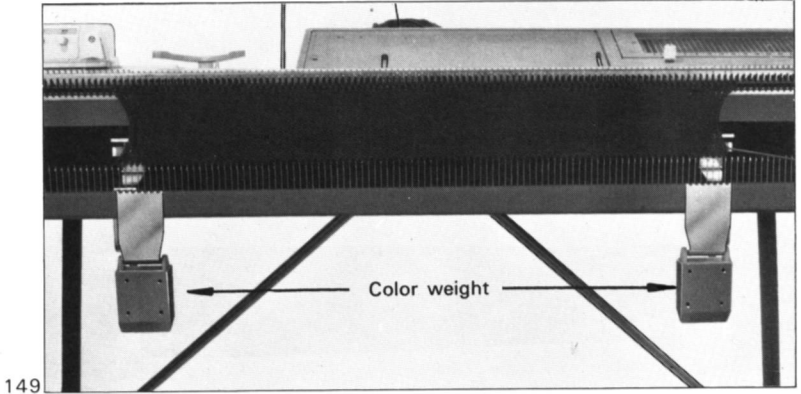

149

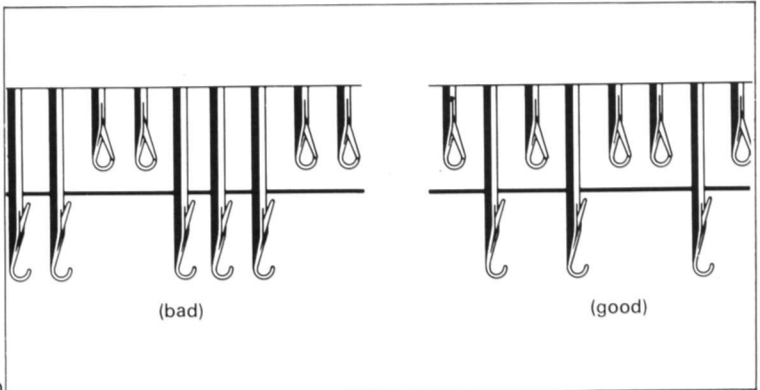

150

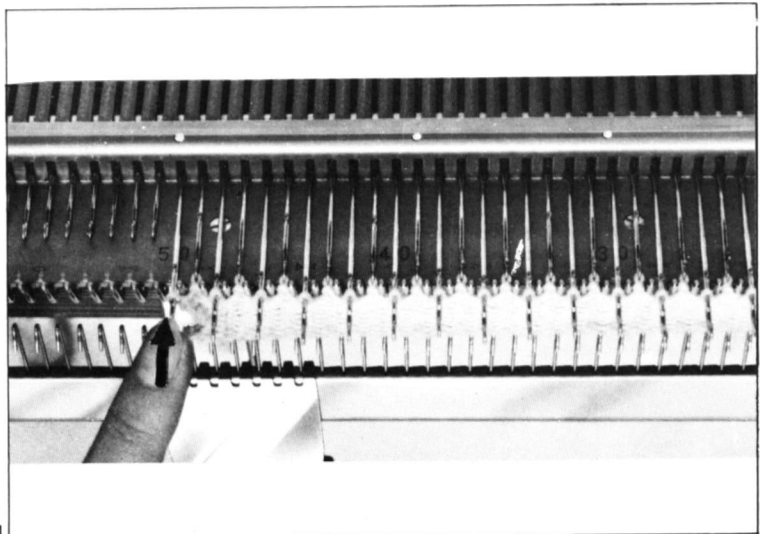

151

FITTING THE 'L' CARRIAGE

The needles at the side of those you are using must all be in Position A.

Put the front part of the carriage around the needle gate, and lower the back part onto the needle bed.

(See Fig. 152). The clip at the back should go under the back rail of the needle bed. Move the carriage sideways to check that it is firmly in place.

IF THE 'L' CARRIAGE SHOULD JAM DURING KNITTING REFER TO PAGE 55 TO RELEASE IT.

152



To unlock the carriage press the release button at the back and release it from under the rail.

(See Fig. 153). To rest the 'L' carriage on the extension rail, place it firmly in position as shown.

(See Fig. 154).

153

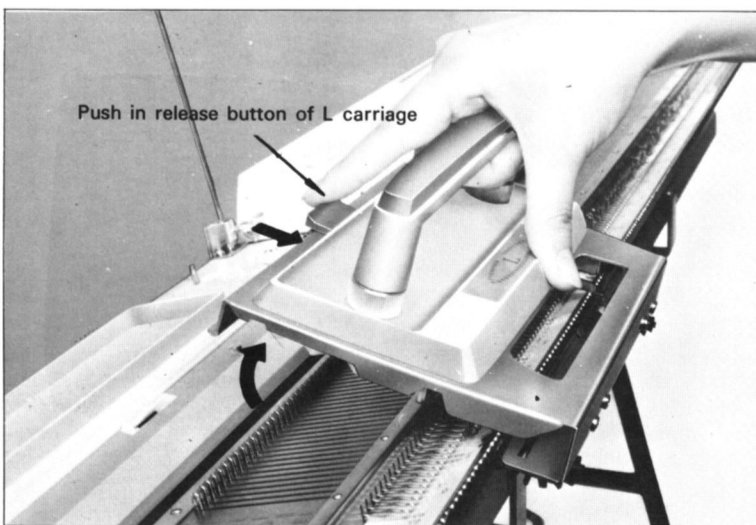

154

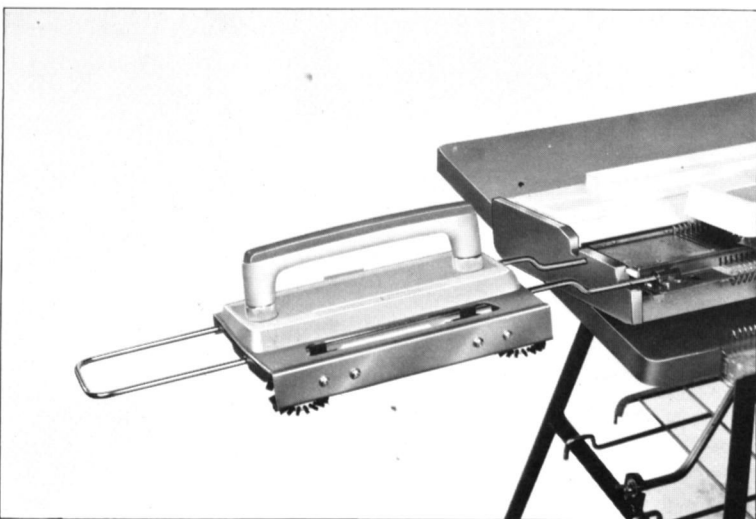

Example of simple Lace pattern (No. 9)

Preparing to knit

1. Take No. 9 operation card and pattern card cassette then set them into the pattern center.
2. Set the automatic pattern repeat regulator to 20th step.
3. Knit few rows of plain knitting and place the carriage to the right.
4. Based on the instruction of operation card, set the machine as follows ;

Tension dial (T.D.) 5
 Yarn in feeder (Y.) Main yarn
 Carriage button (C.B.) PLAIN

Change knob (C.K.) on N
 Weaving button (W.B.) . . on N
 Change lever (C.L.) on N
 5. Set the step indicating lever to the start position.

Knitting

Always watch the step indicator.

Step 1.

- 1) Swivel the set lever.
- 2) Move the "L" carriage across in one movement, from left to right.

3) Knit one row (Move the carriage to left).

Step 2.

- 1) Knit one row (Move the carriage to right).

Step 3.

- 1) Swivel the set lever.
- 2) Move the "L" carriage across in one movement, from right to left.

3) Knit one row (move the carriage to left).

Step 4.

- 1) Knit one row (Move the carriage to right).

Repeat the knitting according to the operation card until 20th step.

REMEMBER : ALWAYS OPERATE THE "L" CARRIAGE BEFORE THE KNITTING CARRIAGE IF THEY ARE BOTH TO BE USED IN THAT STEP. ALWAYS SET THE NEEDLES BEFORE OPERATING THE "L" CARRIAGE. IF AN END NEEDLE IS BROUGHT FORWARD, PUSH IT BACK TO B POSITION.

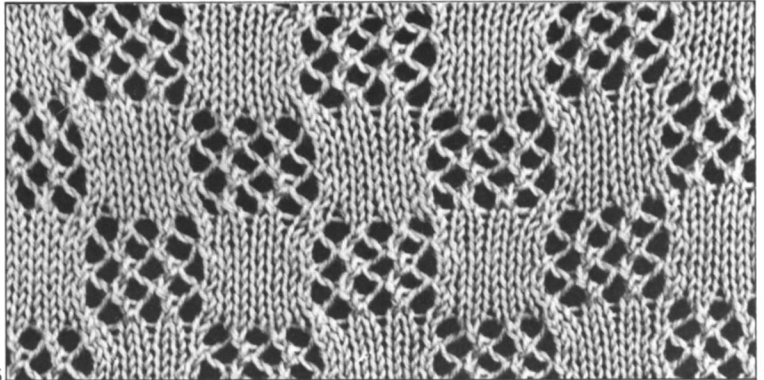

155

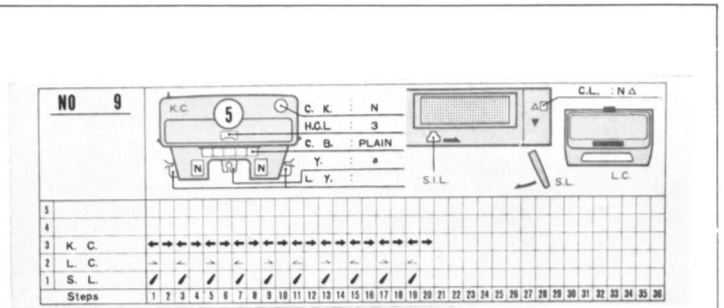

156

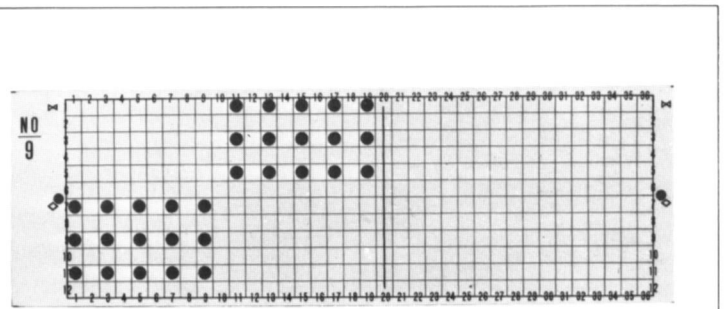

157

Lace pattern (No. 10)

Take the No. 10 operation card and pattern card cassette then place them on the pattern center.

Set the machine according to the operation card.

Knitting

Step 1.

- 1) Swivel the set lever.
- 2) Move the "L" carriage to right.

3) Knit one row (to left).

Step 2.

- 1) Knit one row (to right).

Step 3.

- 1) Swivel the set lever.
- 2) Move the "L" carriage to right.

3) Do not knit in this step.

4. Push the Step indicating lever (S.I.L.) one step to right (set the S.I.L. onto 4th step).

Step 4.

- 1) Swivel the set lever.
- 2) Move the "L" carriage to left.
- 3) Knit one row (to left).

Continue the knitting according to the operation card.

WHEN THE MARK  IS SHOWN IN THE RELATIVE COLUMN FOR EACH STEP, PUSH THE S.I.L. ONE STEP TO RIGHT BY FINGER.

How to use Spare Pattern Card Cassette.

1. Set spare pattern card cassette.
2. Make perforation according to the pattern you wish to produce by using the Puncher.
3. Push the puncher in vertically as far as it will go then take it off.

4. Be sure the step indicating lever is set out of the columns of step to make perforation.

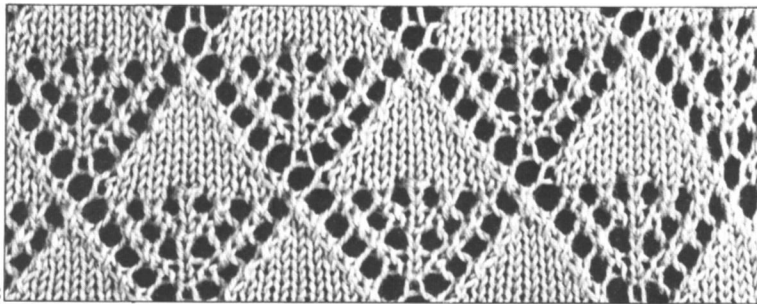

158

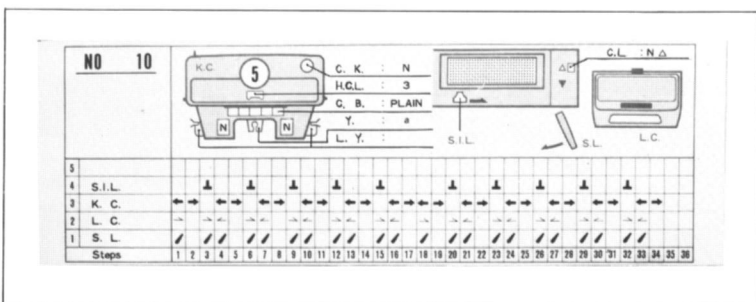

159

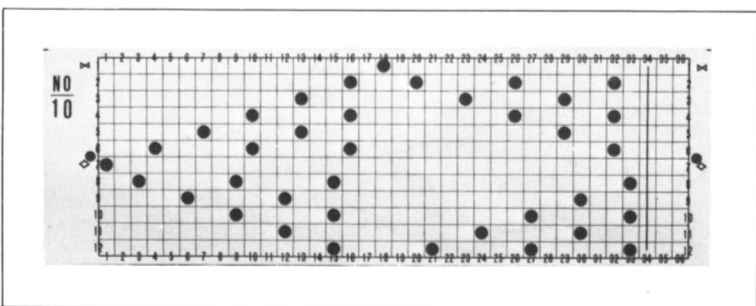

160

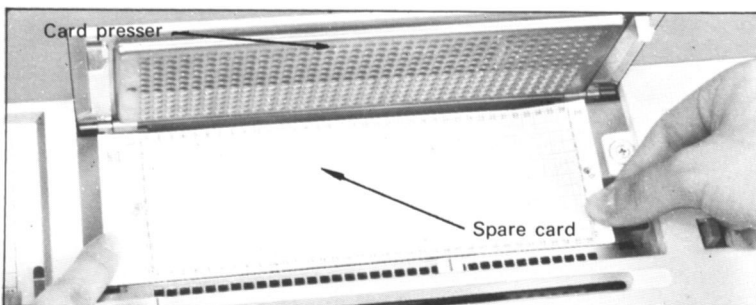

161

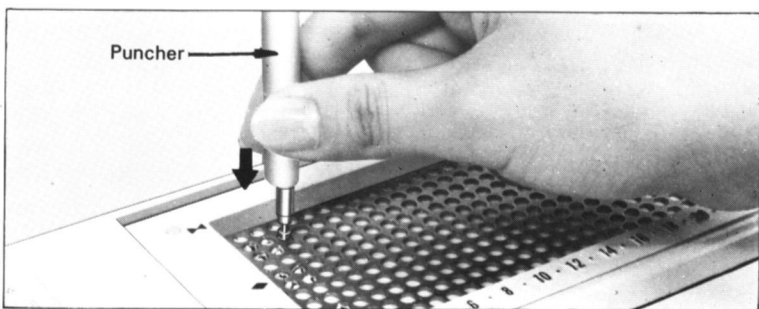

162

ALL THE INSTRUCTION ON THE MACHINE IS NOW FINISHED AND YOU SHOULD GO BACK AND PRACTICE THE THINGS YOU ARE NOT SURE OF

CLEANING AND OILING
A Lubriplate (Special lubricating oil) is supplied in the accessory box. Remove the cap and poke a small hole in the head of tube using a sewing needle. Clean the needle bed and the carriage slide rails with a clean cloth.

163 First, put the lubricant on the cloth (Fig. 163), and rub the front rail, rear rail, butts of the needles with the lubricated cloth (Fig. 164).

After wiping the carriage clean, rub the sides of the moving cams, front and back rails and also the sides of the nylon plastic runners in the center with the lubricated cloth. (See Fig. 165).

YOU SHOULD CLEAN AND OIL YOUR MACHINE BEFORE USING IT EVERY TIME.

It is important to remove well all excessive oil to prevent drying up or staining of your wool. Always leave a light film of oil on all parts between the rails under the carriage.

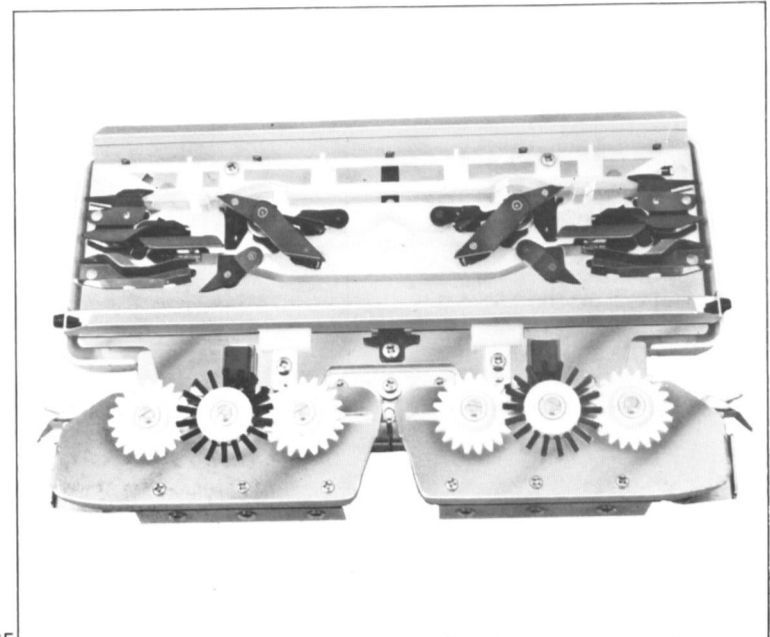
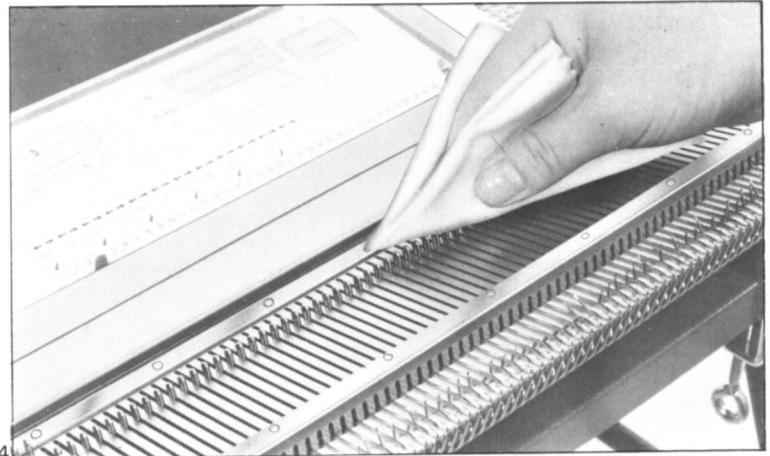
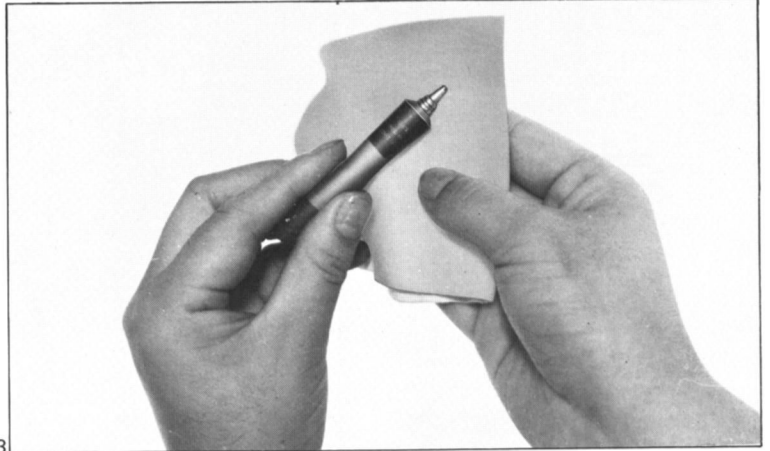

163

164

165

IF THE 'L' CARRIAGE SHOULD JAM

Remove the 'L' carriage from its jammed position.

If the 'L' carriage is caught with the needles, take care in removing it.

After removing the 'L' carriage, you can knit according to the following steps.

(1) If you see needles caught with each other, separate them by lifting their tips.

(2) If stitches are caught on two needles as shown by (a) in above figure, pull selected needles (b) toward you and push them back together with needles (c) to position 'B' in order to transfer the stitches.

(3) For other part, transfer the stitch of selected needles (b) with the transfer tool to the adjacent needles. (For use of the transfer tool' see page 27).

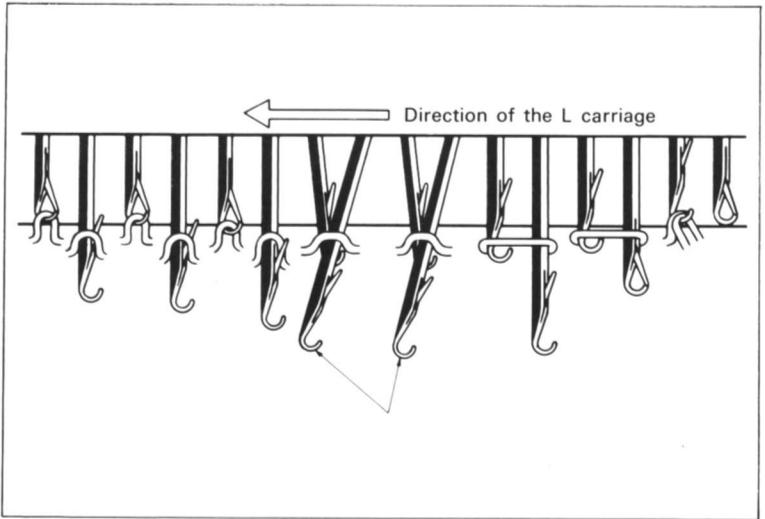

166

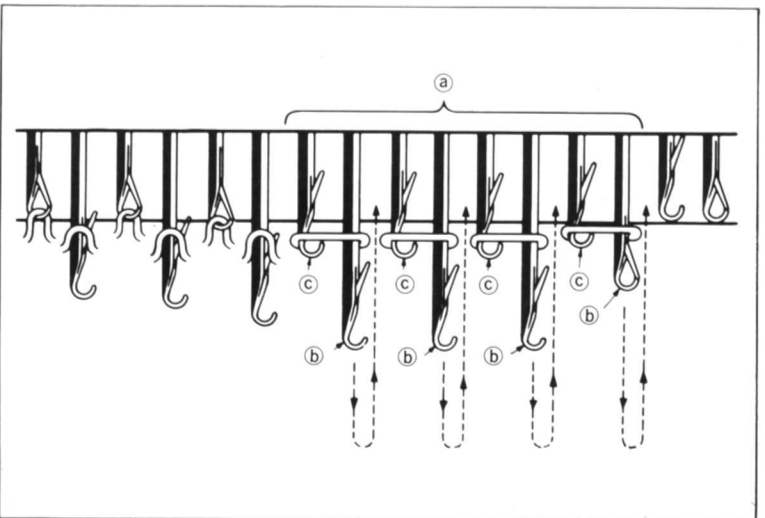

167

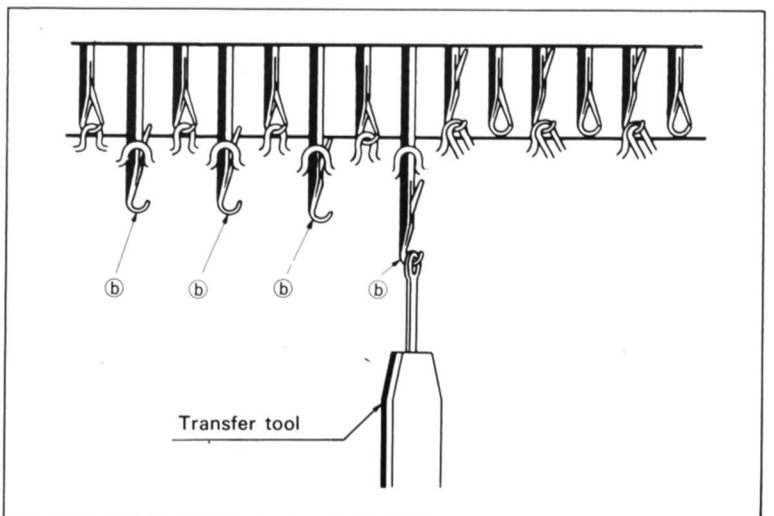

168

REPLACING A BENT OR BROKEN NEEDLE

(1) Push either side of the felt bar with the end of the latch tool until it comes out.

(2) Withdraw it by hand from the knitter until the needle you wish to change is free.

(3) Pull the needle forward as far as it will go. Push down the hook of the needle until shank end of the needle rises clear of the needle bed.

(4) Grasp the shank end and draw it out backwards.

(5) Replace it with a new needle by holding it with latch opened. Push the felt bar back into place.

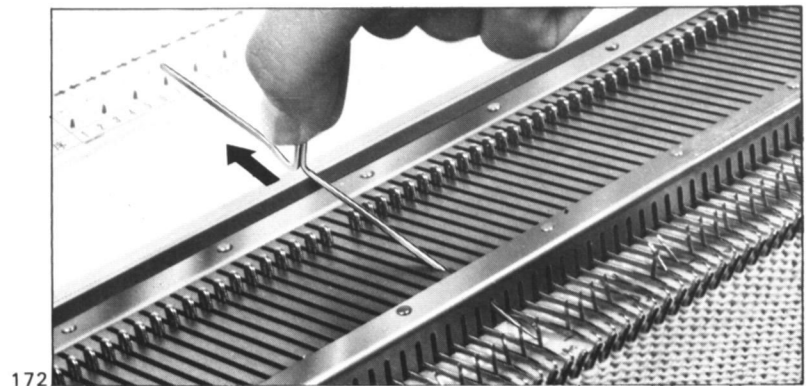
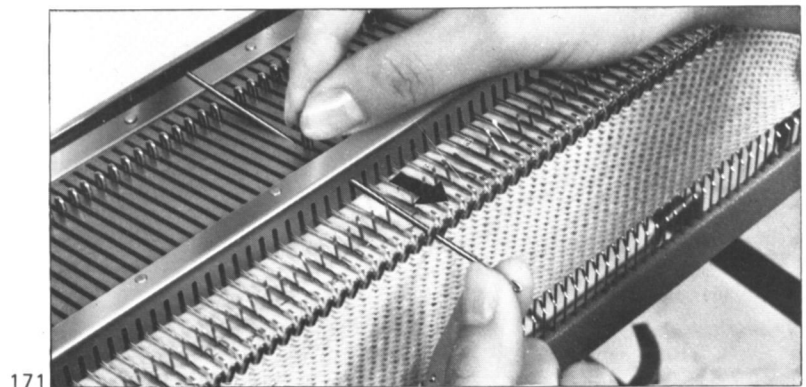
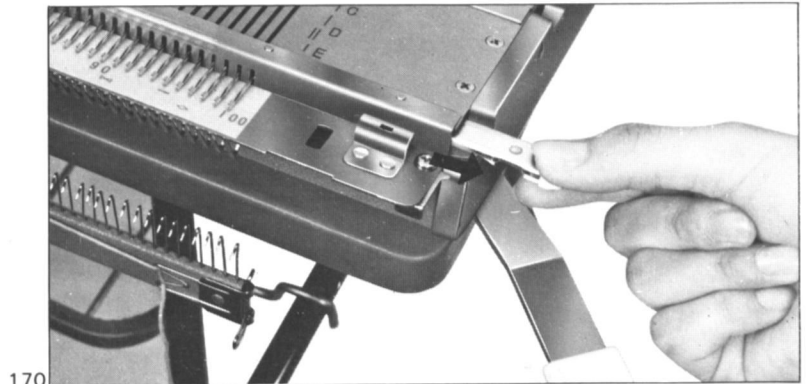
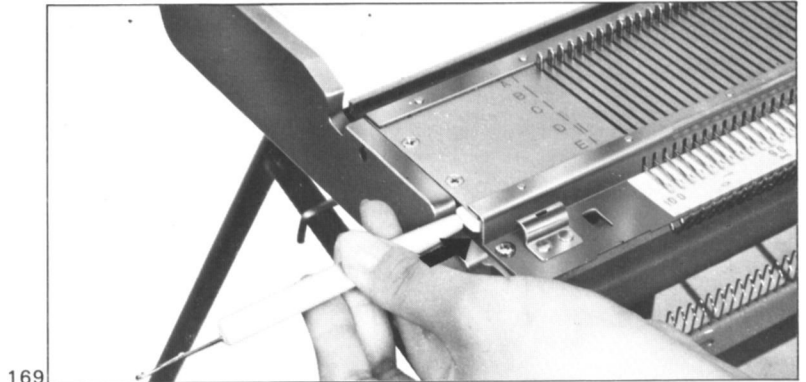

HOW TO REMOVE THE WEAVING BRUSHES

How to remove the weaving brushes

Set the laying-in pattern knobs to position 'N' and remove the laying-in pattern brushes from the sinker plate assembly.

173

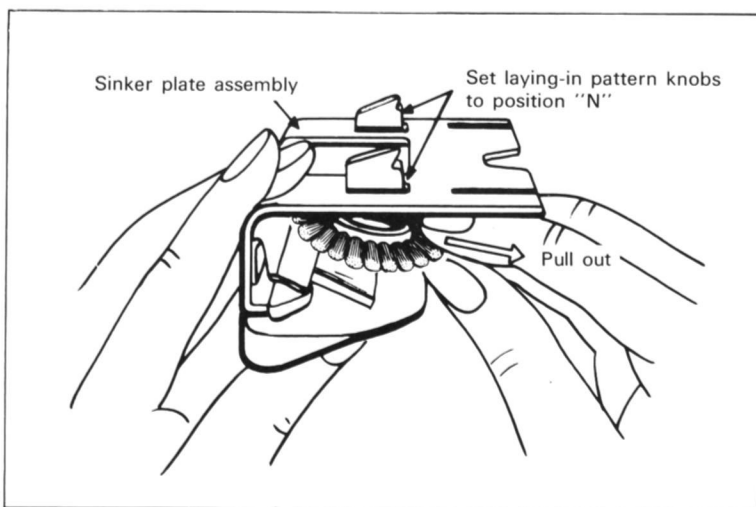

174

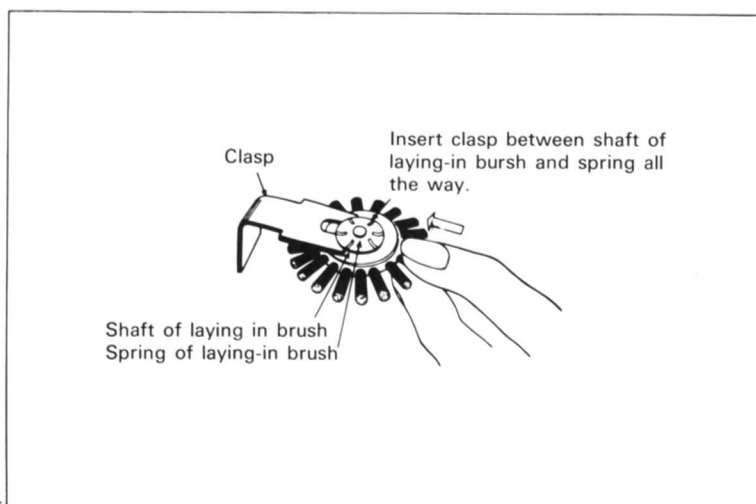

Trying your first garment

58

CHILD'S TWIN SET

We are continually bringing out new pattern leaflets featuring the latest designs, for use on their machines. To familiarise the newcomer to machine knitting with the instructions on these leaflets, we suggest that you try one of the basic patterns given here for practice.

Materials

Cardigan : 5 (5, 6) oz. 4-ply wool (main colour) ; odd amount 4-ply wool (contrast colour) ; 4 buttons.

Jumper : 5 (6, 6) oz. 4-ply wool ; 3 buttons.

Measurements

To fit a 22 (24, 26) inch chest.
Cardigan : Length 13 (14½, 16) inches ; sleeve seam 10½ (11¾, 13) inches. Jumper : Length 12½ (14, 15½) inches ; sleeve seam 10½ (11¾, 13) inches (adjustable).

Tension

14½ sts. and 19½ rows to 2 ins.

Abbreviations

K. Knit ; st. (s) stitch (es) ; rep repeat ; alt. alternate ; beg. beginning ; foll. following ; inc. increase ; dec. decrease ; H.C.L. Holding Cam Lever ; T. tension ; 000. Set Row Counter at 0.

No instructions have been given for the motif, we leave the choice to you.

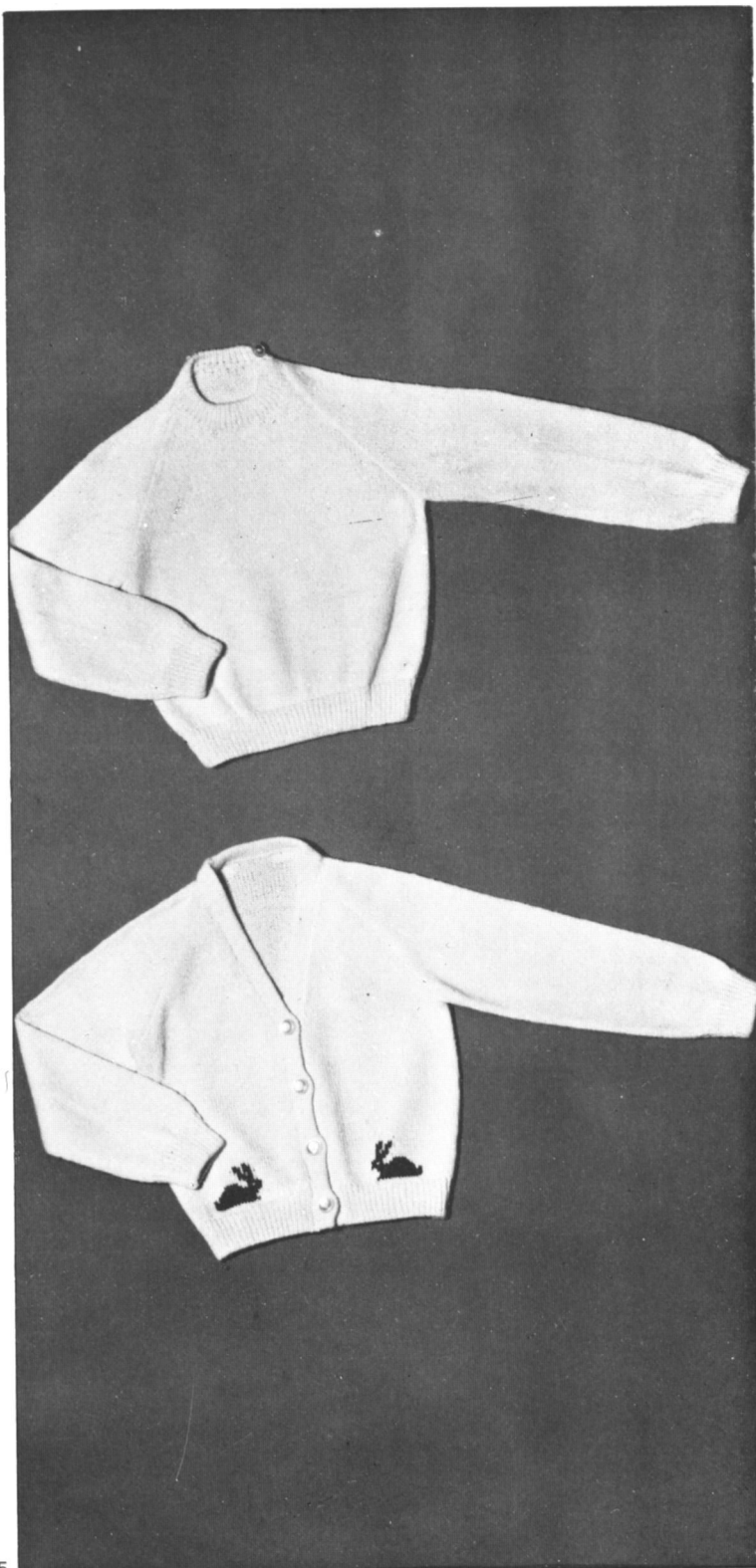

Figures in brackets refer to the larger sizes respectively. Motif is worked by hand. Push required needles to D position. Push both PART buttons. Knit with contrast wool. Push remaining needles to C position and knit with main wool.

CARDIGAN (with motif) BACK

Using odd wool, cast on 44 (48, 52) sts. on alt. needles. K. 7 rows. Change to main wool. T. 3. K. 32 rows. Make a hem by picking up 1 st. row loops of main color and placing on empty needles. T. 7. 000. Inc. 1 st. beg. next row. (88 (96, 104) sts.) K. until 58 (68, 78) rows have been worked.

Shape raglan armholes

Cast off 3 sts. beg. next 2 rows ; 2 (3, 3) sts. beg. next 2 rows. Dec. 1 st. both ends next and alt. rows 25 (27, 30) times. (28 (30, 32) sts.) T. 6. K. 16 rows. Cast off.

RIGHT FRONT

Using odd wool, cast on 22 (24, 26) sts. on alt. needles. K. 7 rows. Change to main wool. T. 3. K. 32 rows. Make a hem as Back. T. 7. 000. Inc. 1 st. at side edge (44, (48, 52) sts.) K. 2 rows Beg. on needle 17 (19, 21) follow chart for motif. (See notes). K. a further 41 (51, 61) rows.

Shape raglan armhole and neck

Dec. 1 st. at neck edge, cast off 3 sts. at raglan edge on next row. K. 1 row. Cast off 2 (3, 3) sts. beg. next row. K. 1 row. Dec. 1 st. at raglan edge on next and alt. rows. At the same time, dec. 1 st. at neck edge on next end foll. 4 rows until 6 (6, 7) sts. remain. Keeping neck edge straight, continue raglan shaping until 2 sts. remain. K. 2 tog. and fasten off.

LEFT FRONT

Knit as Right Front reversing all shapings and motifs.

SLEEVES

Using odd wool, cast on 28

(30, 32) sts. on alt. needles. K. 7 rows. Change to main wool T. 3. K. 32 rows. Make a hem as Back. T. 7. 000. Inc. 1 st. beg. next row. (56 (60, 64) sts.) K. 7 rows. Inc. 1 st. both ends of next and foll. 14th (12th, 10th) rows 6 (8, 10) times. (68 (76, 84) sts.) K. until 88 (100, 112) rows have been worked. (Adjust length here, if required).

Shape raglan top

Cast off 3 sts. beg. next 2 rows ; 2 (3, 2) sts. beg. next 2 rows. Dec. 1 st. both ends next and alt. rows 25 (27, 30) times. Cast off remaining 8 (10, 10) sts.

Buttonhole Border

Join front raglan seam. With wrong side facing, pick up 98 (110, 122) sts. evenly along one front. T. 6. K. 5 rows. Counting from base of garment, make a buttonhole over needles 7-10 (8-11, 6-9) and every foll. 12-15 (14-17, 17-10) needles 4 times altogether. K. 8 rows. Make buttonholes as before. K. 4 rows. Cast off loosely.

Button Border

Knit as Buttonhole Border omitting buttonholes.

TO MAKE UP

Pin out and press with a hot iron over a damp cloth. Join side, sleeve and back raglan seams. Turn Front Border to wrong side and catch down. Neaten buttonholes. Sew on buttons. Press all seams.

JUMPER

BACK

Using odd wool, cast on 44 (48, 52) sts. on alt. needles. K. 7 rows. Change to main wool. T. 3. K. 32 rows. Make hem as Back of Cardigan. T. 7. 000. Inc. 1 st. beg. next row. (88 (96, 104) sts.) K. until 54 (64, 72) rows have been worked.

Shape raglan armholes

** Cast off 3 sts. beg. next 2 rows ; 2 (3, 3) sts. beg. next 2 rows * Dec. 1 st. both ends and alt. rows 25 (27, 30) times, altogether. Cast off remaining 28 (30, 32) sts.

FRONT

Knit as Back to * Dec. 1 st. both ends of next and alt. rows 17 (18, 20) times altogether. K. 1 row.

Divide for neck

H.C.L. 2. Cast off 12 (14, 16) sts. at center. Push sts. at left to E position. Knit right part first. Continue raglan shaping, K. 1 row. Cast off 2 sts. at neck edge on next and foll. alt. row. K. 2 rows. Dec. 1 st. at neck edge on next and foll. 4th row (4 (5, 6) sts.). Keeping neck edge straight, continue raglan shaping until 2 sts. remain. K. 2 tog. and fasten off. Knit 2nd side to match.

SLEEVES

Using odd wool, cast on 27 (30, 33) sts. on alt. needles. K. 7 rows. Change to main wool. T. 3. K. 32 rows Make a hem as Back. Inc. 1 st. beg. row. (54 (60, 66) sts.) K. 5 rows. Inc. 1 st. both ends of next and foll. 20th (18th, 18th) row 4 (5, 6) times. (62 (70, 78) sts.) K. until 86 (98, 112) rows have been worked. (Adjust length here if required).

Shape raglan top

Cast off 2 sts. beg. next 2 (4, 4) rows. 1 st. size only. K. 2 rows. All sizes : Dec. 1 st. both ends next and alt. rows 25 (27, 30) times. Cast off remaining 8 (8, 10) sts.

NECKBAND

Using odd wool, cast on 51 (54, 57) sts. on alt. needles. K. 7 rows. Change to main wool. T. 4. K. 3 rows. T. 3. K. 12 rows. T. 4. K. 3 rows. Make a hem as Back. Cast off loosely.

TO MAKE UP

Pin out and press with a hot iron over a damp cloth. Join side, sleeve and raglan seams, leaving left back seam open for 2½ ins. Sew neckband in position. Work a row of crochet round opening, making 3 loops on one side. Sew on buttons. Press all seams.

Man's fully fashioned polo neck sweater

60

MATERIALS : 24 (25, 26) ozs. of any Double knitting wool.

MEASUREMENTS : To fit chest 40 (42, 44) in. ; length, 26½ (27, 27½) in. ; sleeve seam, 17½ (18, 18½) in.

MAIN TENSION : 13 stitches and 18 rows to 2 inches.

ABBREVIATIONS : T. = tension st(s). =stitch(es) ; K. =knit ; beg. =beginning ; dec. =decrease ; f.f. =fully fashioned (transfer the 3rd st. onto the 4th needle then transfer the 5th st. onto the 4th needle. 3 sts. on 1 needle. Move the sts. along to fill up the spaces, leaving 2 empty needles at outside edge. Push 1 needle back to A position leaving 1 needle in B position, thereby dec. 1 st. only. To achieve the best results do this dec. at the end away from the carriage) ; H.C.L.=holding cam lever ; 000 = row counter at 0 ; inc. =increase.

NOTE : Instructions for the larger sizes are in (), where only 1 figure is given this applies to all sizes.

BACK : T. 4. Cast on over alternate needles 70 (73, 76) sts. K. 38 rows. Make a hem by placing each cast-on st. onto empty needles in A position (140 (146, 152) sts.) T. 9 and K. 126 rows.*

Shape raglan armholes : Cast off 2 sts. at beg. of next 2 rows. Dec. 1 st. f.f. at the end of every following row until 42 (44, 46) sts. remain. Cast off.

FRONT : Work as for back until *

Shape raglan armholes : Cast off 2 sts. at beg. of next 2 rows. Dec. 1 st. f.f. at end of every following row until 68 (70, 72) sts. remain.

Shape front neck : With a spare length of wool, cast off the center 20 (22, 24) sts. Push 24 sts. at left to E position. H.C.L. at 2 and K. the right part only. Continue raglan shaping as before. At the same time cast off 2 sts. at beg. of next 3 rows from neck edge, then dec. 1 st. at the beg. of every following 4th row from neck edge, 3 times in all. After the last dec. at neck edge continue to dec. at side edge only until 2 sts. remain. Cast off. K. the left side to match.

SLEEVES (alike) : T. 4 Cast on over alternate needles 34 (36, 38) sts. K. 38 rows. Make a hem as for back. (68 (72, 76) sts.) T. 9.000. K. 6 rows. Inc. 1 st. at both ends of the next row and every following 6th

row until 110 (116, 122) sts. Work without further shaping until 140 (144, 148) rows from 000.

Shape raglan top : Cast off 2 sts. at beg. of next 2 rows. Dec. 1 st. f.f. at end of every following row until 12 (14, 16) sts. remain. Cast off.

POLO COLLAR : T. 5. Cast on over alternate needles 70 (74, 78) sts. K. 12 rows. T. 4. K. 34 rows. T. 5. K. 12 rows. Make a hem as for back. Cast off loosely.

TO COMPLETE : Press work on the wrong side with a hot iron over a damp cloth. Join raglan seams. Join side and sleeve seams. Stitch polo collar to neck edge.



Folding up the knitter

- (1) Remove the extension rail (lift up and pull it.)
- (2) Replace the extension rails in the upper case as shown in figure.
- (3) Replace the cast on comb in the case.
- (4) Fold up the automatic yarn tension unit. Remove the automatic yarn tension unit.

177

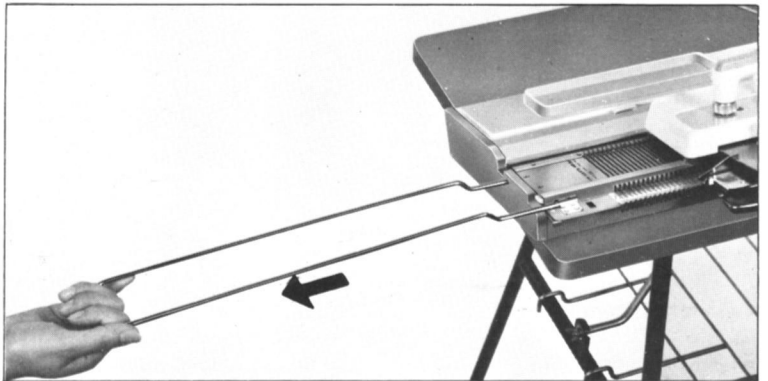

178

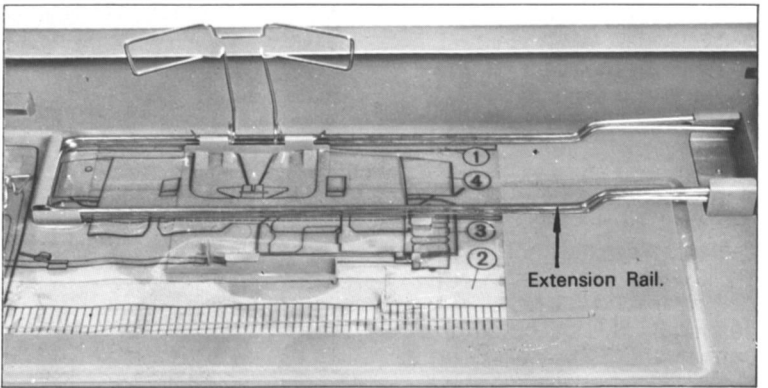

179

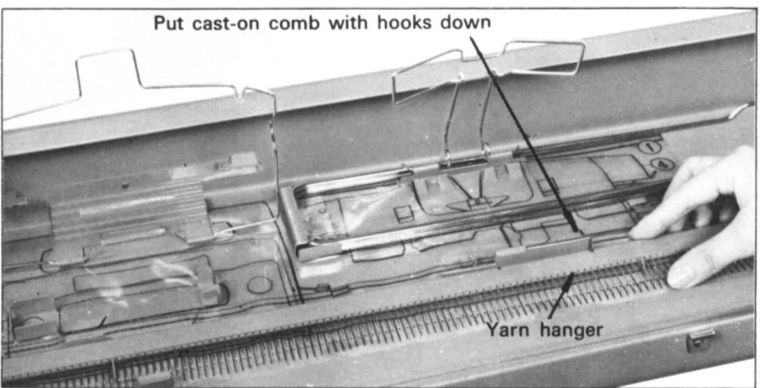

180

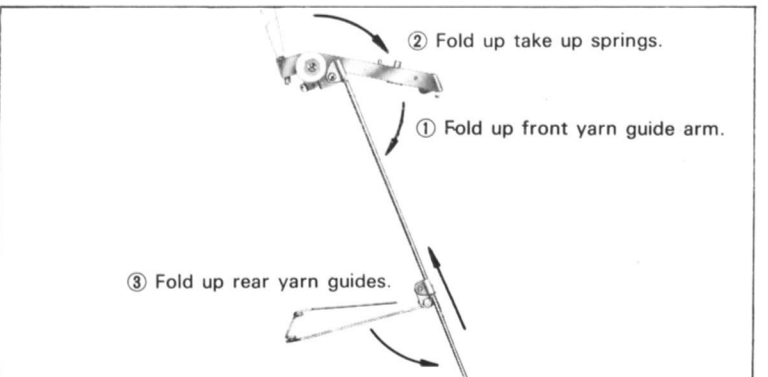

(5) Replace the automatic yarn tension unit as shown in figure. (Fit the head A of automatic yarn tension unit under the clasp B of the case.)

(6) Place the yarn tension rod and the take-up spring beside comb and put them inside of hook C. And place the sinker plate as shown in figure.

(7) Remove the set lever from the machine and replace it as shown in figure.

(8) Remove handle from the 'L' carriage and replace the 'L' carriage as shown in figure.

(9) Close the springs.

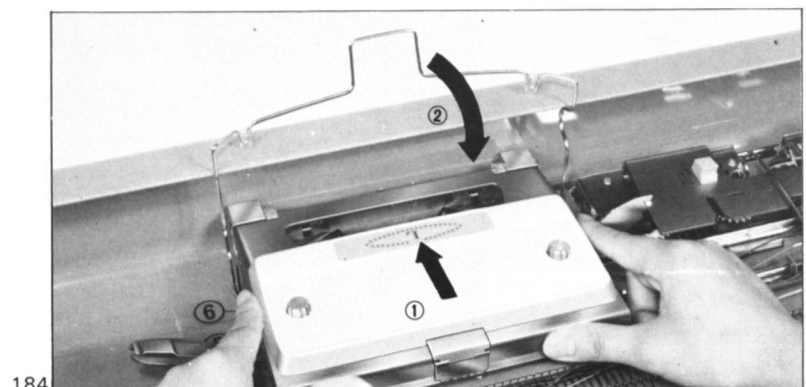
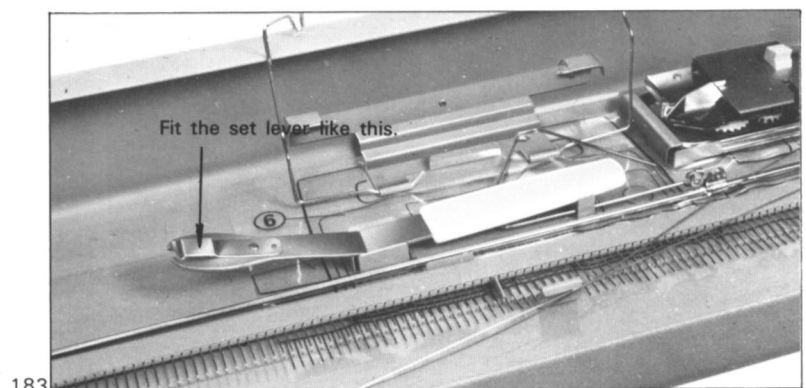
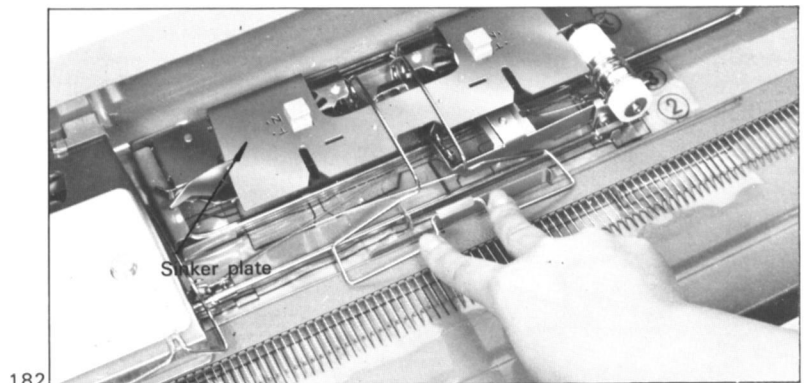
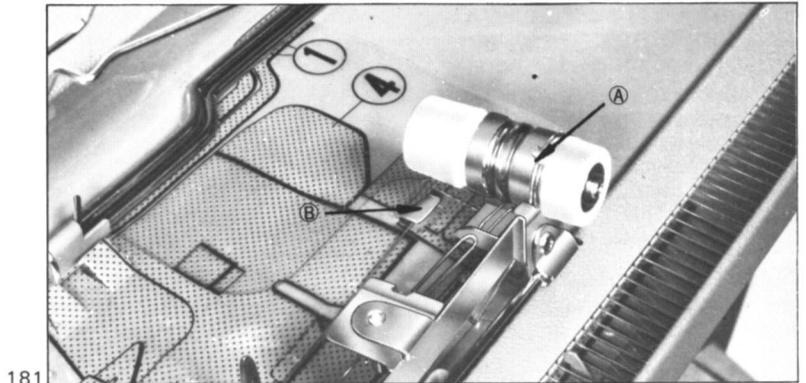

(10) Take out the carriage lock from the accessories box and lock carriage on the left end of the needle bed.

(11) Remove the handle of the carriage, table clamps and set lever. Replace them and other accessories in the accessories box.

(12) Put the Lid for accessories box.

185



186

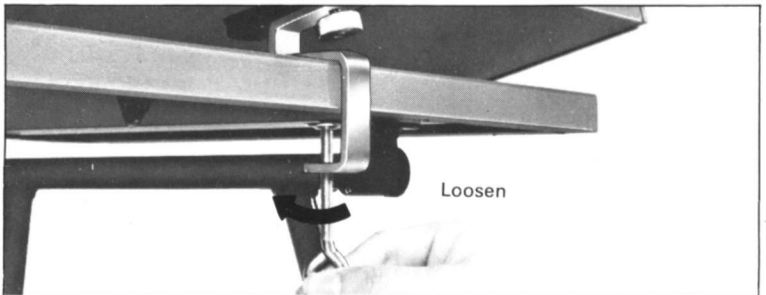

187

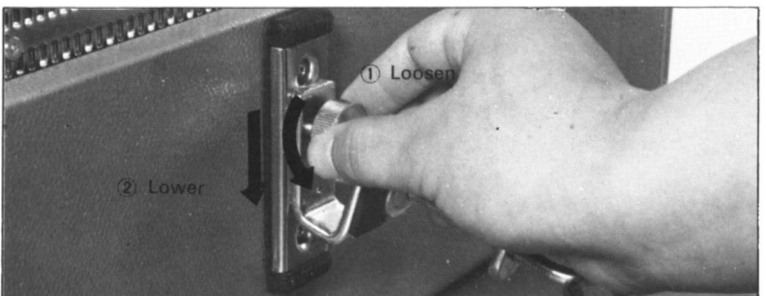

188

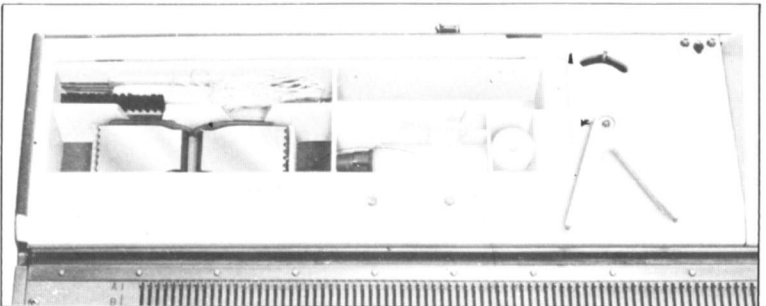

189

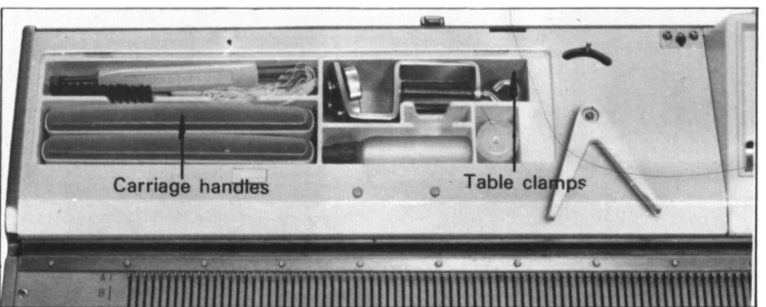

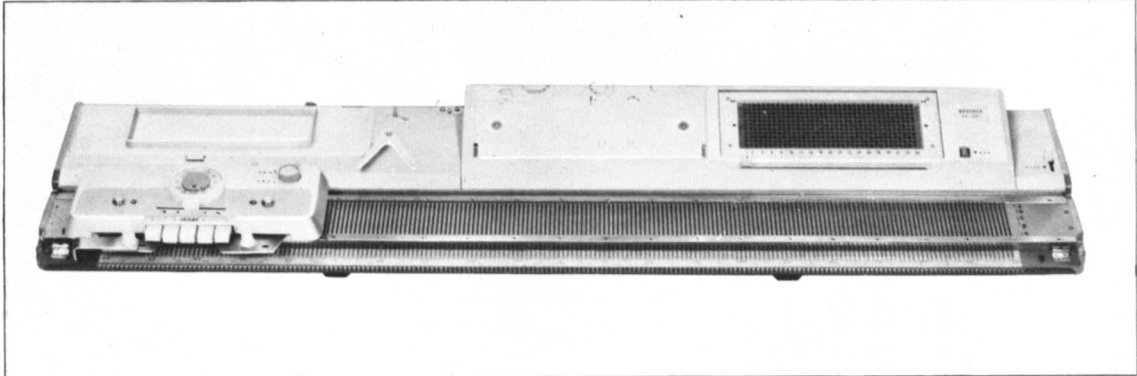

190

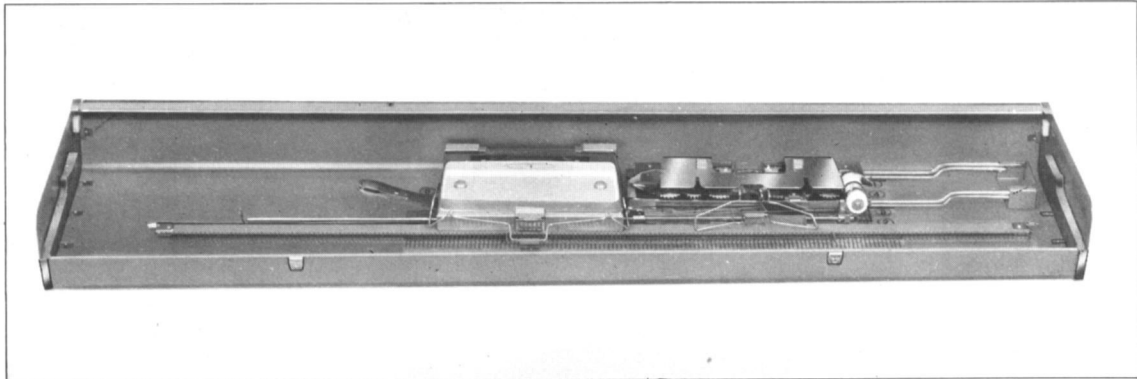

191

(13) Put the Pattern card cassette and Operation card set on the Accessories box.

(14) Close the carrying case. Lock the two catches.

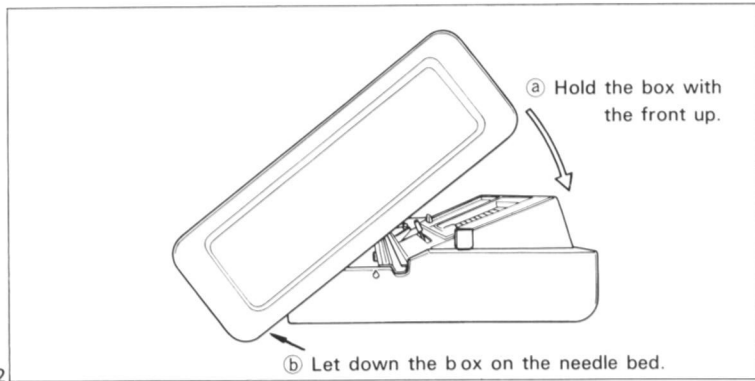

192

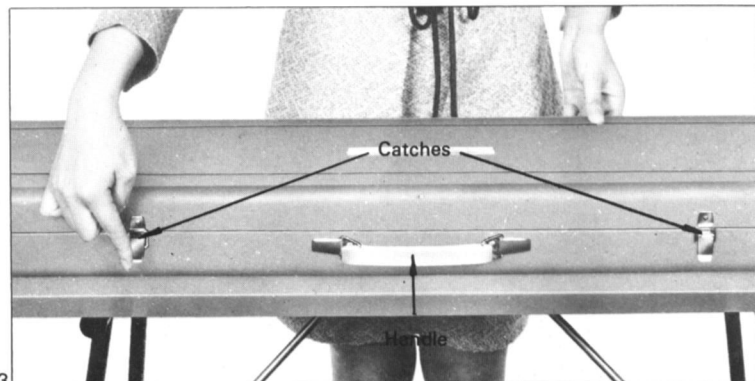

193

I N D E X

Name of parts	1
Setting up your machine	3
Setting up the carriage	5
Assembling the yarn tension	6
Important points to remember before you start knitting	7
Winding the wool	7
Tension dial and Needle positions	8
Functions of the Carriage	10
Preparing to do the plain knitting	13
If the carriage should jam and how to unravel a row	18
Knitting a plain hem	20
Knitting an elastic hem	22
Automatic cast-on	24
Finished edge cast-on (Hand method)	25
Knitting a picot hem	26
Picking up dropped stitches	26
How to use the transfer tool	27
Increasing stitches	28
Transferring to hand knitting needles	29
Decreasing stitches	30
Casting-off	31
Button-holes	32
How to knit a pocket	34
Shaping a "Vee" neck	35
Shaping a round and square neck	36
Short row designing	37
How to use the pattern center	38
Explanation of the Operation Card and the Pattern Card Cassette	42
Simple Pull-up stitch pattern (No. 1)	43
Fair Isle pattern (No. 4)	45
How to weave on your machine	47
Automatic lace pattern	49
How to use spare pattern card cassette	53
Maintenance	54
If the "L" carriage should jam	55
Replacing a bent or broken needle	56
Trying your first garment	58
Man's fully fashioned polo neck sweater	60
Folding up the knitter	61

