

Name of parts.....Carriage and Machine body

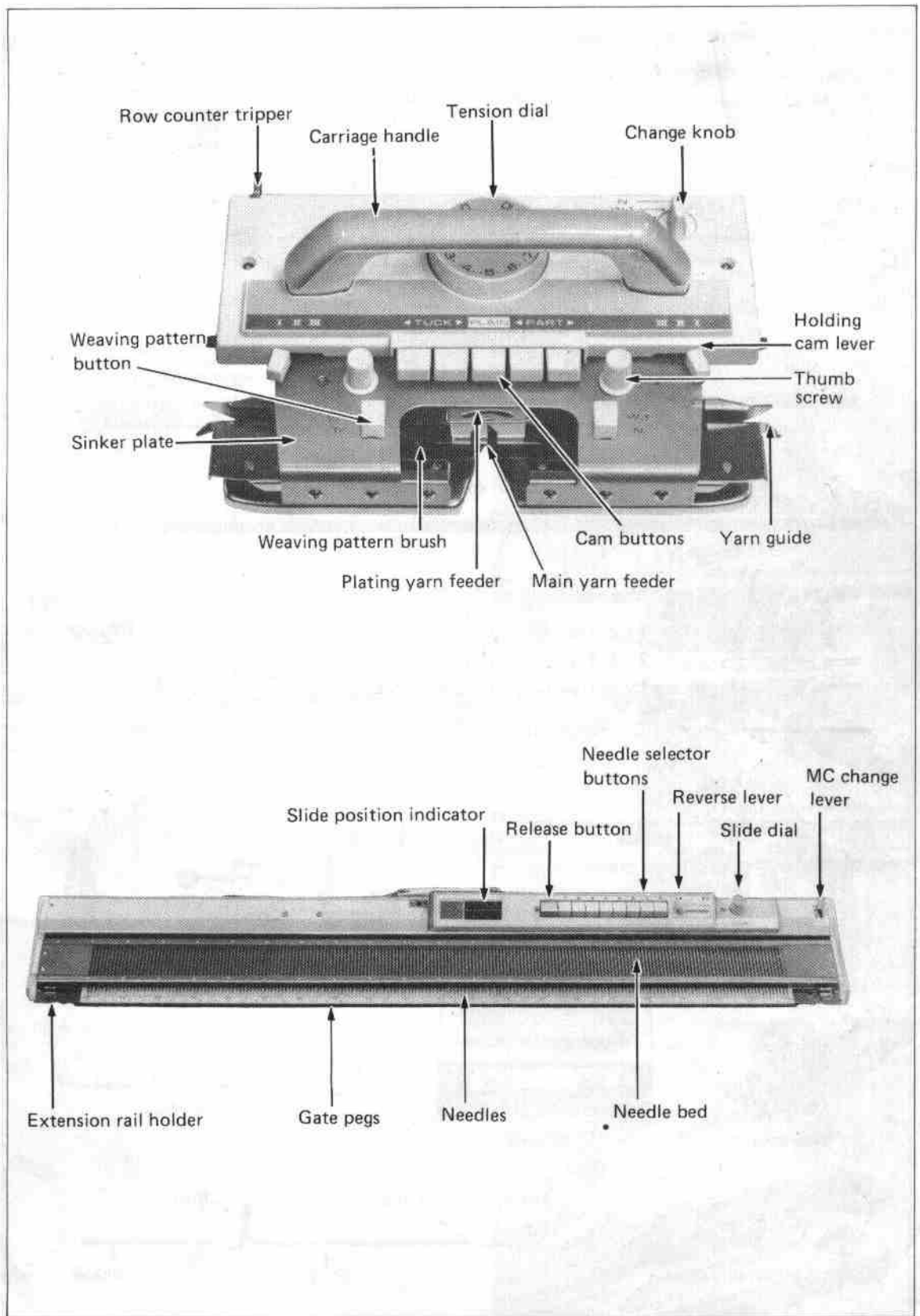

Accessories

Automatic yarn tension unit

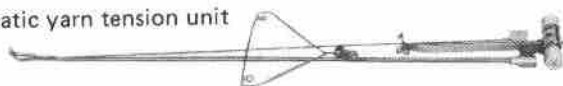

Claw weights

Extension rails



1/1 Needle pusher

Cast-on comb, short

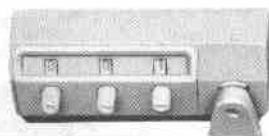

Row counter

Cast-on comb, long



Latch tool



1 x 2 Transfer tool



2 x 3 Transfer tool



1 x 3 Transfer tool



Crochet needle



Spare needles

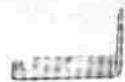

Carriage lock



Wax



Hand brush



Accessories box



Table clamps



Oil



Wax case



"L" carriage



Set lever



Cast-on thread

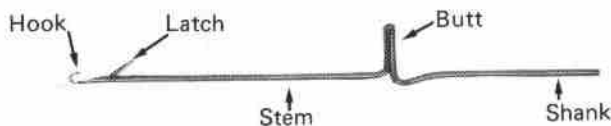

Setting up your machine

1. Turn over the machine and remove the lock pin which is fixed by the tape.

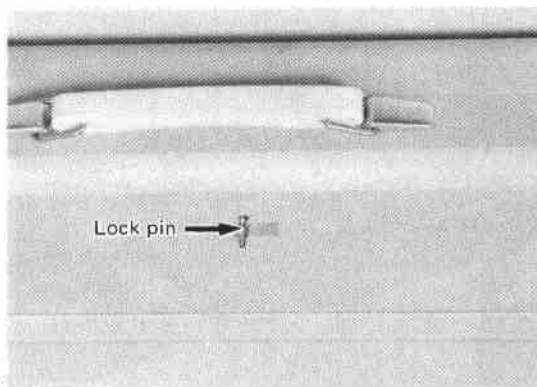

2. Place the machine on a firm table, with the carrying case handle away from you. Unlock the catches on either side of the handle.

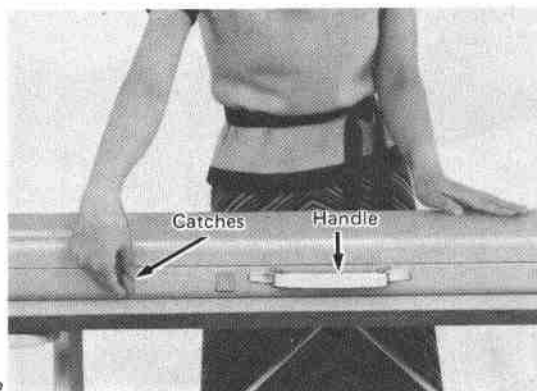

3. Lift the upper case slightly, and pull towards you to release the lid.

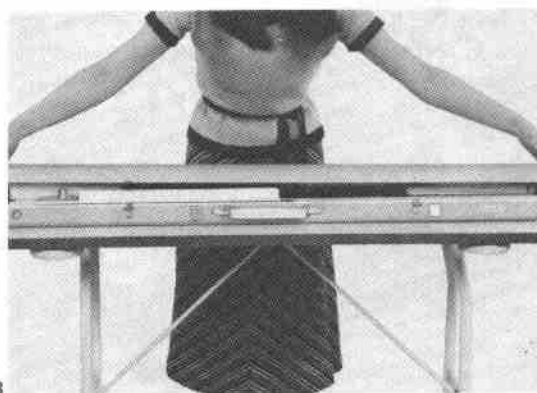

4. Remove the accessories box.

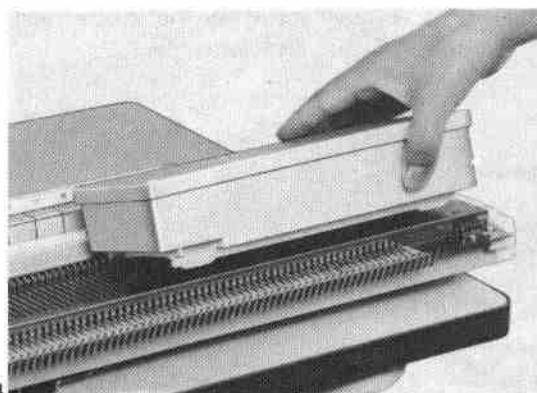

5. Take the two table clamps out of the accessories box, and fasten the knitter to the table by tightening the Table clamp screws.

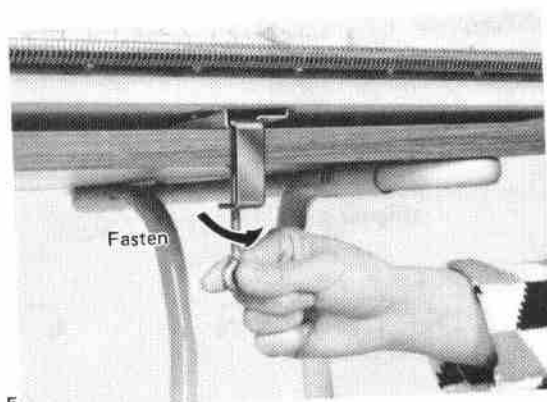

5

6. Remove the Carriage lock.

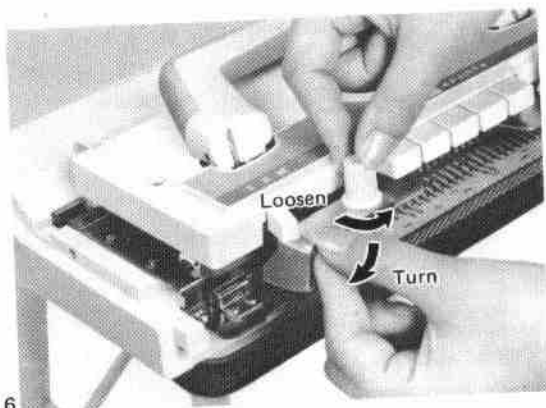

6

7. Take the row counter out of the accessories box, and set it onto the two studs and push it away from you.

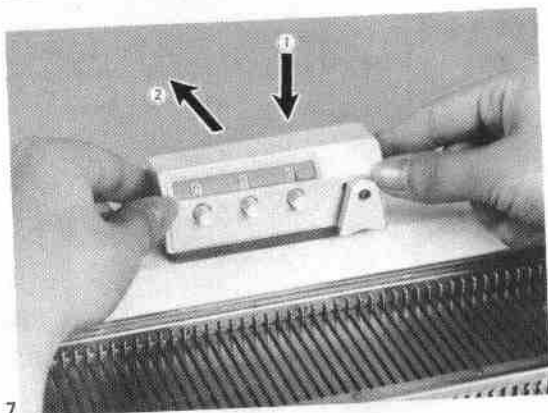

7

8. Press down the spring in the centre, and remove the Sinker plate assembly.

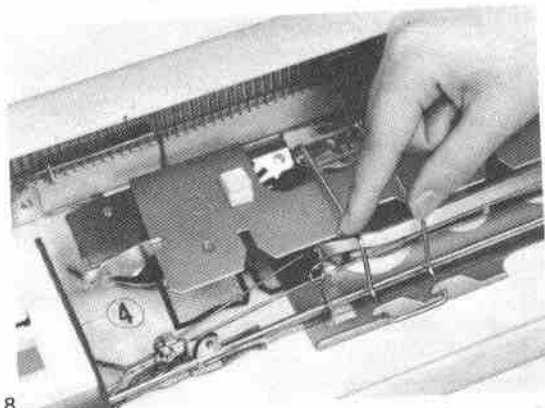

8

SETTING UP THE CARRIAGE

9. Slide the Carriage to the centre of the machine. (Before doing so push back the butts of all the needles as far as they will go.)

Loosen the white plastic thumb screws on the Carriage, and insert the Sinker plate unit. Push it back as far as it will go, and tighten the thumb screws securely. Make sure that the raised metal studs line up with the holes in the Sinker plate unit.

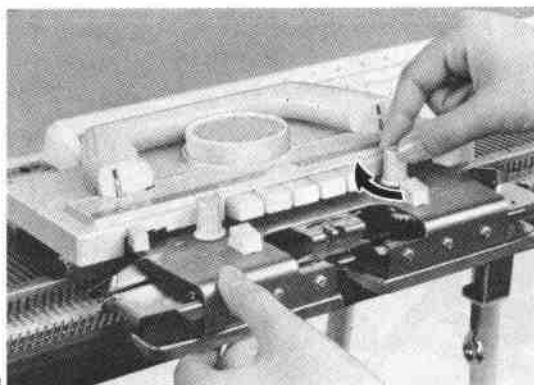

9

10. Fit the set lever onto the shaft at the rear right of the machine.

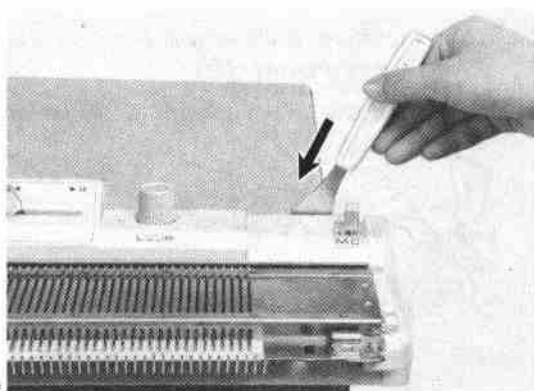

10

11. Pull the L carriage handle to set up it. Then, push the release button on the L carriage and remove the L carriage.

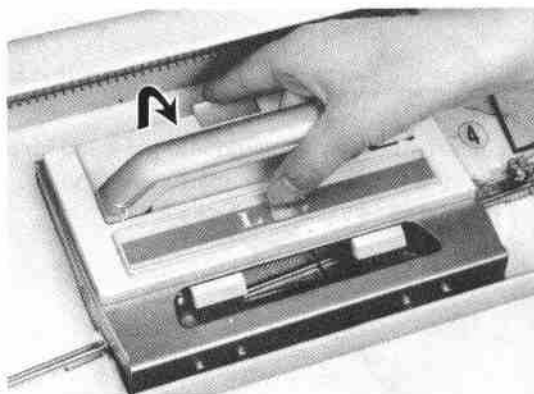

11

12. Pull the Carriage handle towards you and set it up.

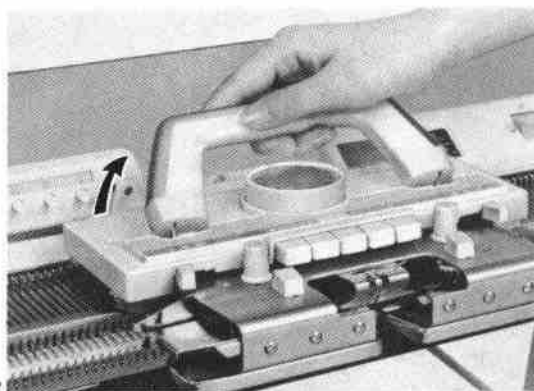

12

13. Remove the Yarn tension unit from the Carrying case.

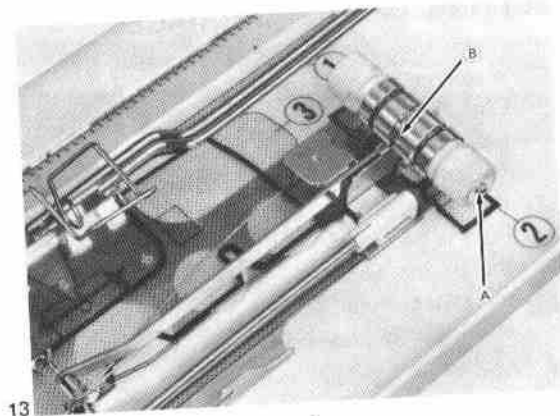

14. Turn the front guide arm forward in the direction of the arrow.
15. Turn back the "Take-up springs" as far as they will go.

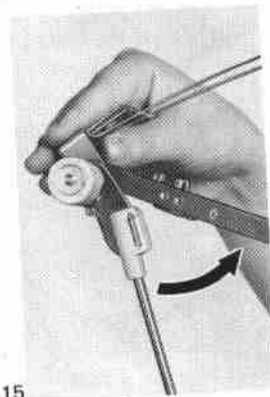
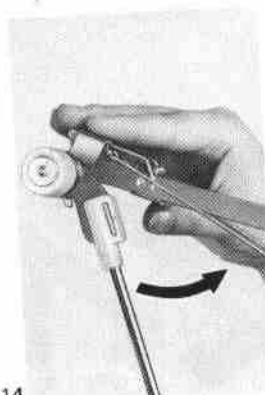

16. Raise the rear guide until it is perpendicular to the rod.
17. Insert the end of the rod into the stand hole at the centre of the machine. The rear yarn guide should face backwards.

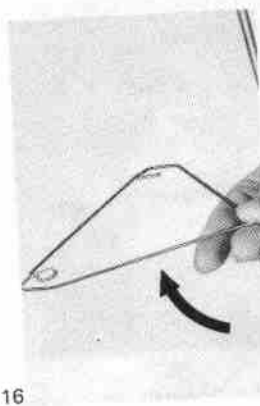

Here are a few important points to remember before you start knitting

WOOL

There are many different types of wool that can be knitted on your machine-but for the purpose of learning or practicing, it is best to use a standard 3 or 4 Ply yarn. Choose a good quality, one that can be knitted over and over again.

WINDING THE WOOL

The wool you purchase will be wound in either balls or hanks, both of which unwind slowly when knitted by hand. Machine knitting is much faster, and requires that the wool be loosely wound so that it unravels freely. You should therefore re-wind all wool into a ball, using a wool winder.

This way you can also make sure that there are no knots or flaws in the wool-that you might otherwise discover too late. If you do discover any knots, try to ensure that they come at the end of a row and not in the middle of the knitting. (See Fig. 18).

WAXING THE WOOL

For thicker wools or wool of uneven texture it is recommended that you wax the wool before using. To make this easier for you we have built into the Yarn Tension Unit a special wax stand, which automatically applies a small amount of wax to the wool as it passes through the unit. Waxing will smooth the small hairs in the wool, and allow it to run through the machine easily. All traces of the wax will disappear after the garment is pressed. (See Fig. 19).

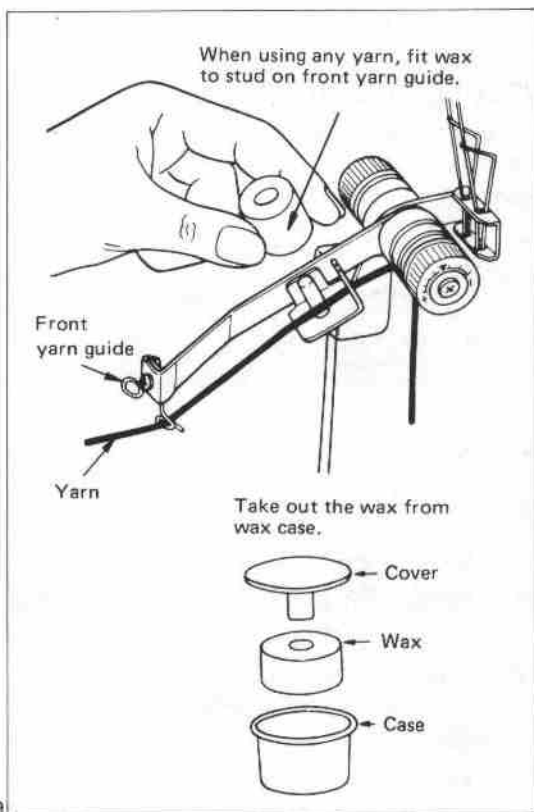
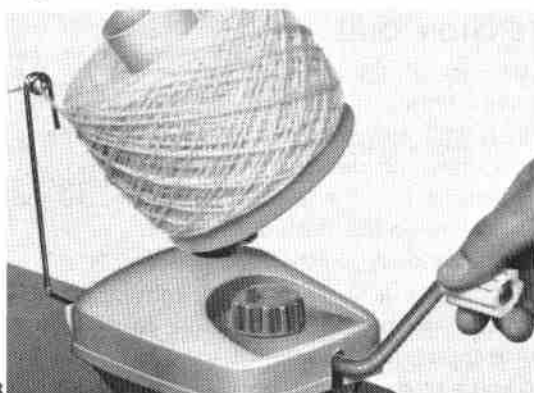

WOOL TENSION

The tension that the wool will feed into the machine is governed by the unit at the top of the Yarn Tension Unit.

The spring discs allow the wool to pass through easily or tightly depending upon the thickness of the wool. A tight tension (towards the +) is used for thin yarns and a loose tension (towards the -) for thick wools. The tension we recommend for a 3 Ply wool is where the two arrows meet. (See Fig. 20).

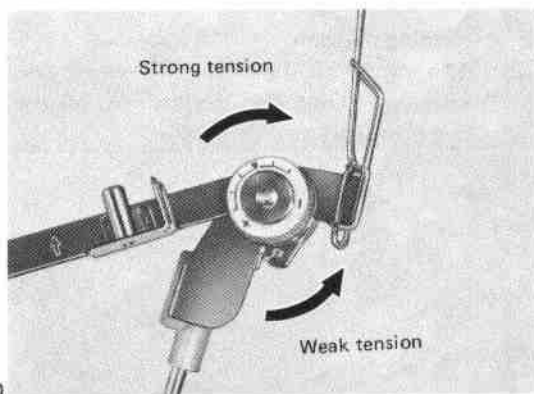

TENSION DIAL

The size of the stitch is determined by the tension setting on the Carriage tension dial. This dial is graduated from 0 to 10, each space being subdivided into three parts. 0 denotes the tightest tension (i.e. the smallest stitch) and 10 the largest tension (i.e. the loosest stitch).

The tension at which your garment is to be knitted is usually given in the knitting pattern instructions, but as this is liable to differ for different brands of wool, it is advisable always to knit a tension swatch sample before commencing your garment. (See Fig. 21).

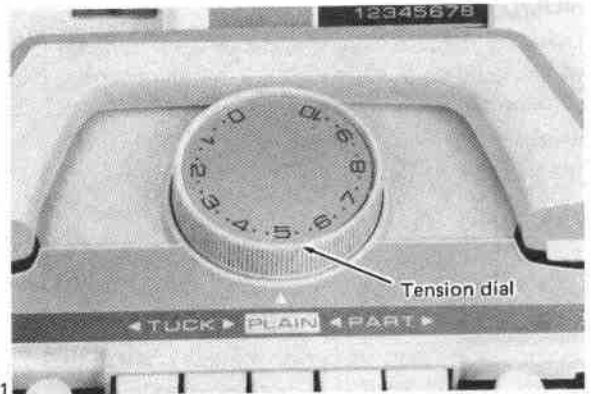

Suggested Tension No.

Yarn	Tension No.
Fine (ex. 2 ply)	0 ~ 3
Medium fine (ex. 3 ply)	3 ~ 4
Medium (ex. 4 ply)	4 ~ 6
Bulky (ex. 5 ply)	6 ~ 10

NEEDLE POSITIONS

On either side of the needle bed there appear the marks A, B, C, DI, DII and E. These are the needle positions. (See Fig. 22).

- A - Non working position.
Needles will not knit.
- B - Working position.
Used for general work.
- C - Partial knitting position for Pull-up stitch and Tuck stitch pattern.
- DI - Pattern knitting position.
Selected needles are brought to this position.
- DII - Pattern knitting position.
Selected needles for Fair-isle pattern are brought to this position.
- E - Holding position.
The stitch will hold on the needle until released. Used for shaping e.g. pockets and buttonholes.

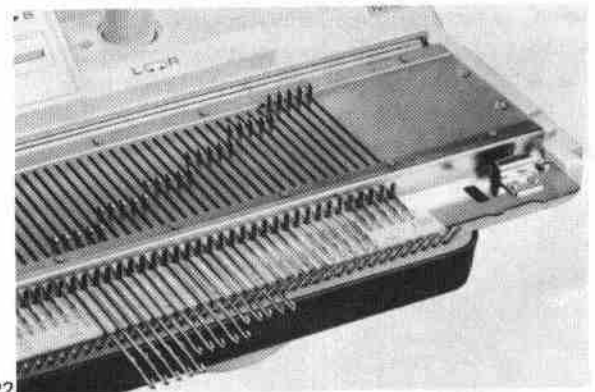

Functions of the carriage

The movement of the carriage across the needles in action (Position B), automatically knits each needle in turn; thereby knitting one row. Once the carriage has been moved across the needles in one direction, it cannot be returned until that row has been completed. At the end of a row you will hear a "click" from the carriage, which signifies that the row has been completed and you can then return.

It is advisable not to move the carriage too far away from the end needles after completing a row, as this will tend to slacken the tension in the springs on the return movement.

CARRIAGE BUTTONS

There are five buttons on the front of the Carriage. They are used for various stitch patterns to set the Carriage to enable it to knit various stitches. The arrow above the button shows that the Carriage is set for that direction. If both buttons are depressed together, the Carriage will be set for both directions.

PART—These buttons are used mainly for Fair-isle and Skip stitch patterns. If both buttons are in, and the needles are not set, the Carriage will move across needles without knitting the stitches.

PLAIN—This button is pushed to cancel the cam button previously set. It does not remain in.

TUCK—These buttons are used to form tucking stitch patterns.

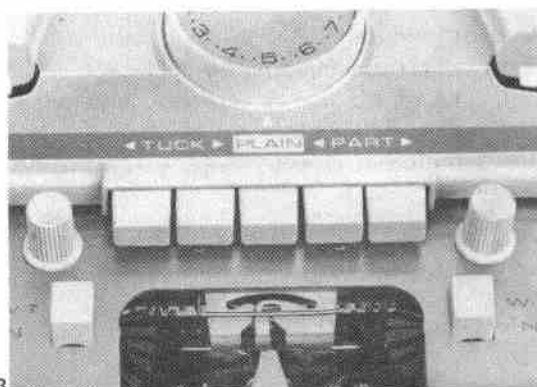

HOLDING CAM LEVERS (H.C.L.)

The H.C.L.'s on either side of the carriage have three positions marked on the carriage, I, II and III.

- I : All needles set forward to C, DI, DII or E positions will return to working position B.
- II : Intermediate position, this position is used when both I and III positions are to be used (i.e., when knitting a "V" neck with a pattern).
- III : Holding position. Any needles brought forward to positions C, D or E will not knit if the H.C.L. closest to the knitting is on III.

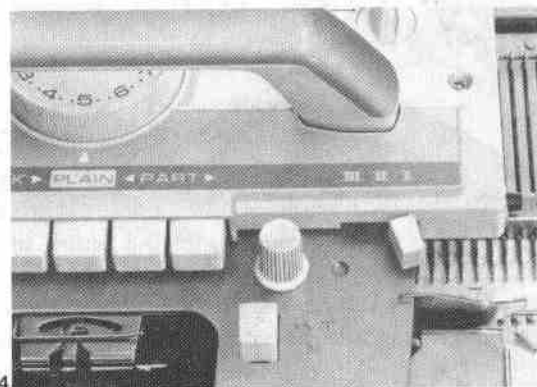

CHANGE KNOB

There are three settings on this control.

- N : For normal knitting, lace knitting, part and tuck knittings.
- W.T : For weaving thread knitting.
- MC : For fair-isle knitting.

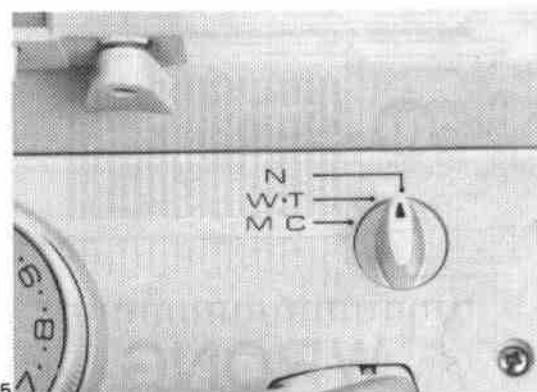

WEAVING PATTERN BUTTONS



26 27

These buttons are used for Weaving patterns.
 N : Upper position is normal position.
 W.T : Lower position is for weaving patterns.
 Press the buttons to set and pull the buttons to cancel.

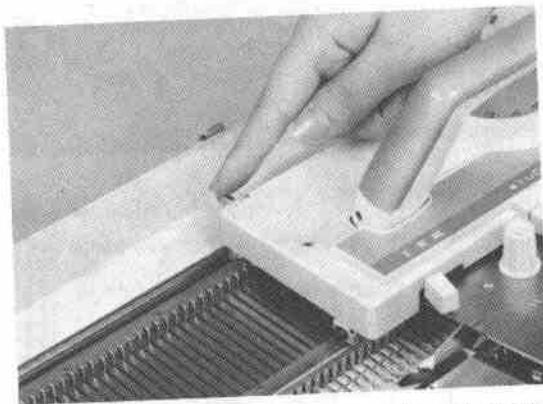

28

When using the row counter, set the tripper to working position.
 If you do not wish to use the row counter, then pull the tripper back to resting position.

ROW COUNTER

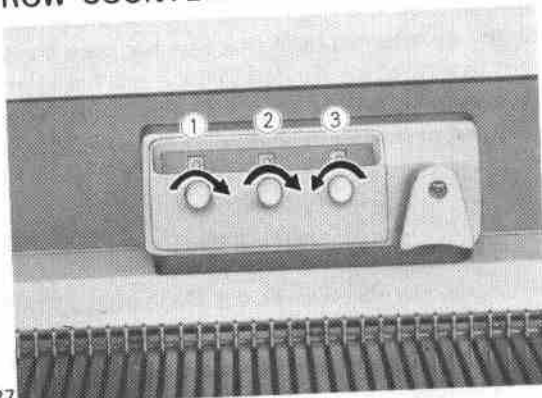

The figures on your row counter can be moved to zero by turning the dials according to the arrows in order from the left.

IT IS IMPORTANT TO REMEMBER THAT THE CARRIAGE SHOULD NOT BE MOVED ACROSS THE NEEDLE BED UNLESS ALL THE NEEDLES ARE ALIGNED IN EITHER OF THE FOUR POSITIONS.

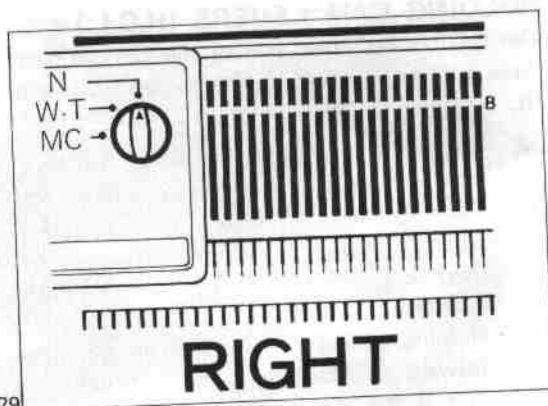

29

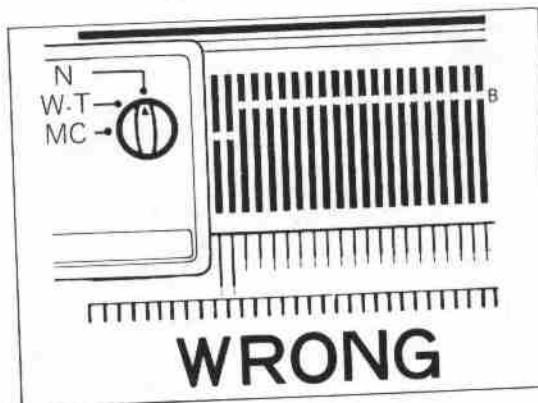

30

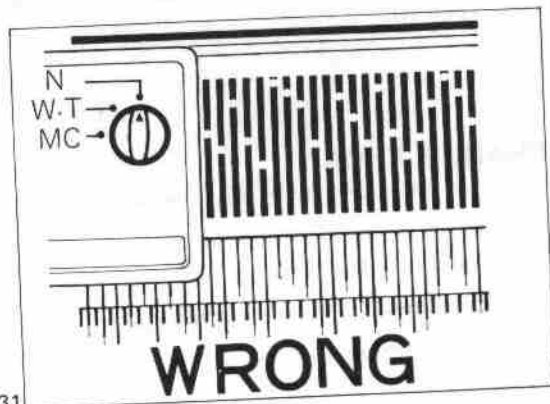

31

Preparing to knit

STEP ONE—

The Carriage.

The photo shows the various controls of the Carriage that you should remember.

- (1) Set the tension dial to 5 for medium thickness yarn. (Ex. 3 or 4 ply)
- (2) Set both weaving pattern buttons to N.
- (3) Set the change knob to N.
- (4) The Holding cam levers to I.
- (5) Push the PLAIN button to set the carriage for plain knitting.

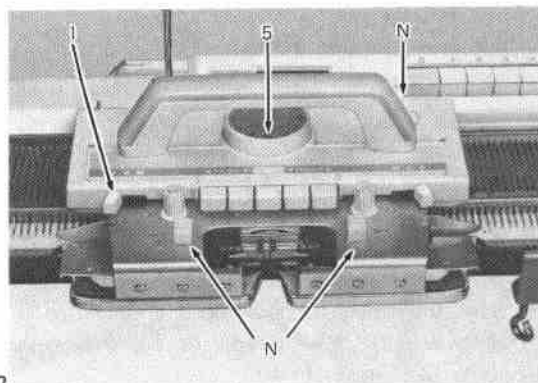

32

STEP TWO—

The Needle Bed.

- (1) Bring forward by using the needle pusher provided in the accessories box 60 needles to position B, 30 needles on either side of the centre mark "0".
- (2) Move the Carriage across and back to straighten these needles into B position completely.
- (3) Place the Carriage at right hand side of the needle bed.

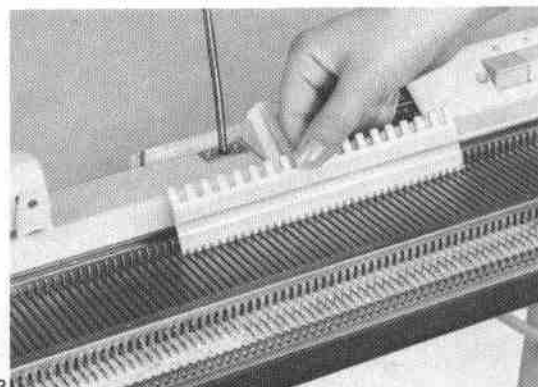

33

STEP THREE—

Threading the Yarn tension unit.

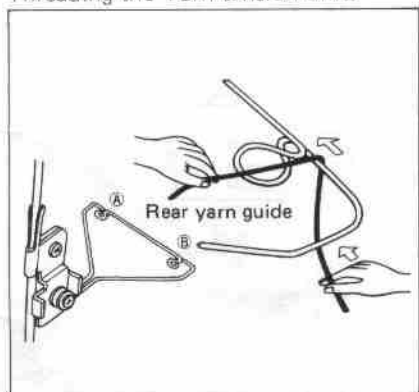

34

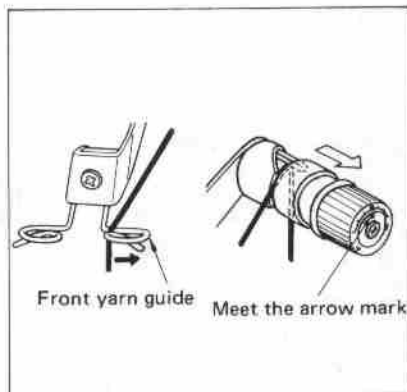

35

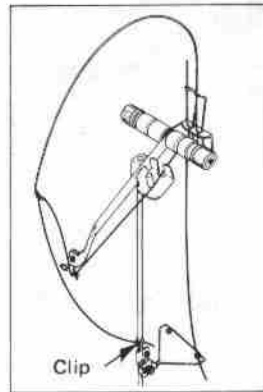

36

- (1) Pass the yarn from the ball through the Rear yarn guide as shown in fig. 34.

- (2) Pass the yarn under the pin and through between two discs, from behind. (See Fig. 35).

- (3) Thread the front yarn guide. Meet the arrow mark for medium thickness yarn. (See Fig. 35).

- (4) Thread the yarn into the eyelet of the Take-up spring and clip the yarn under the Yarn clip.

**STEP FOUR—
CASTING ON.**

(1) Hold the cast-on comb, with the wire hooks facing you, and turn securing levers at both ends to face you. Place hooks between the pegs of needle bed as far up as possible, then turn the two securing levers on comb outwards and the cast-on comb will hang correctly on the knitter. Use the small cast-on comb and centre it between the 50th needle on the right and left. See Fig. 37 to 40.

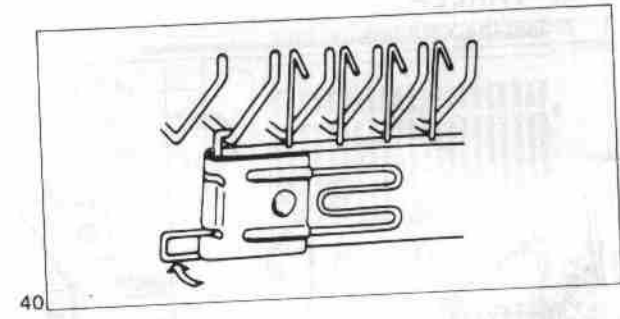
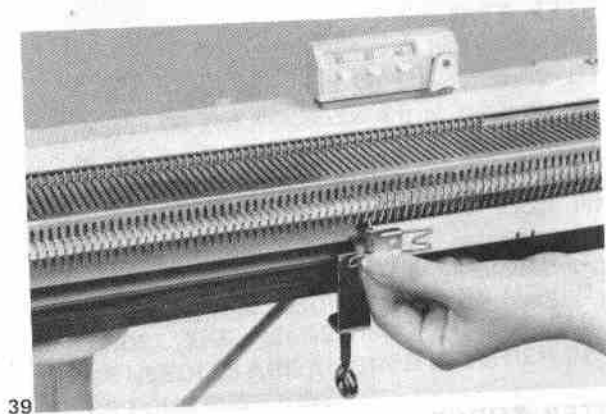
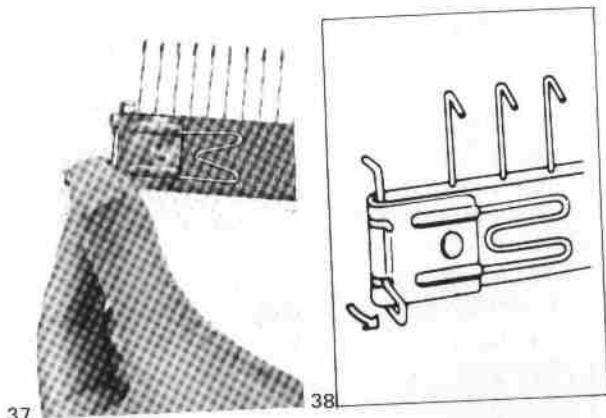

(2) Take the end of the yarn which has been clipped onto the yarn tension rod. Hold the yarn from below with your left hand and from above with your right hand, pass the yarn under the wire (see illustration) and push the yarn into the yarn feeder (right slit).

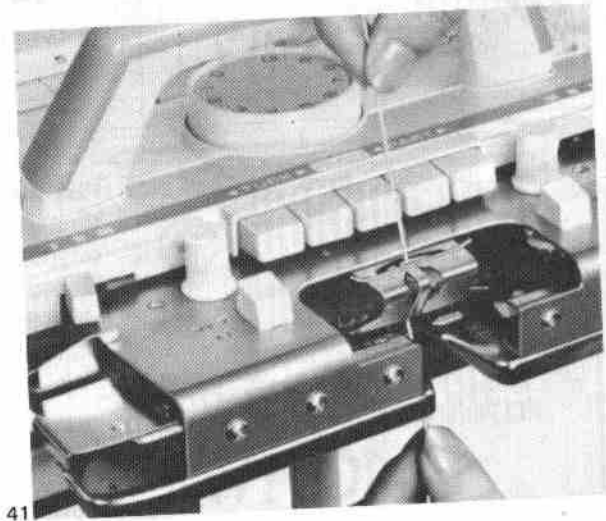
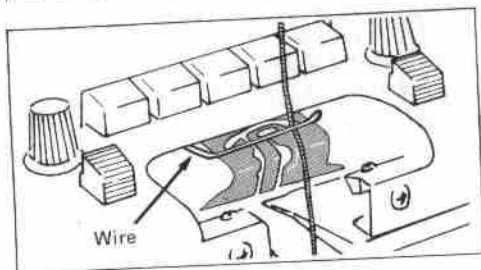

(3) Continue to hold the yarn below with your left hand, and take back any slack yarn through the yarn tension unit (i.e., the take up spring should be bent forward).

(4) Still holding the yarn below the Carriage with your left hand, slide the Carriage across the needles with your right hand until you hear a "click".

N.B. Always move the Carriage across until you hear the click at the end of a row.

You will now have a loop around each needle and under each peg of the comb. If a few end needles have been pulled forward from position B then simply push them back by hand before continuing.

(5) You can now lower the cast on comb by turning the end levers (at the same time) towards you. This will release the comb from the gate pegs and you can allow it to drop slowly.

Note: The cast-on loops are still loose so take care not to turn the comb out of a vertical position or the loops may fall off.

(6) Raise the yarn from the comb to the Carriage, so that it goes under the last comb peg, adjacent to the end needle and above the rest. (See Fig. 45).

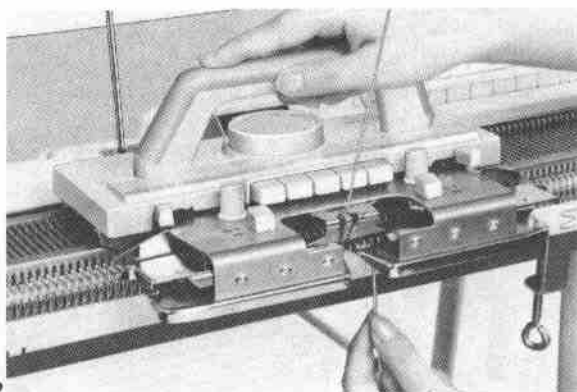

42

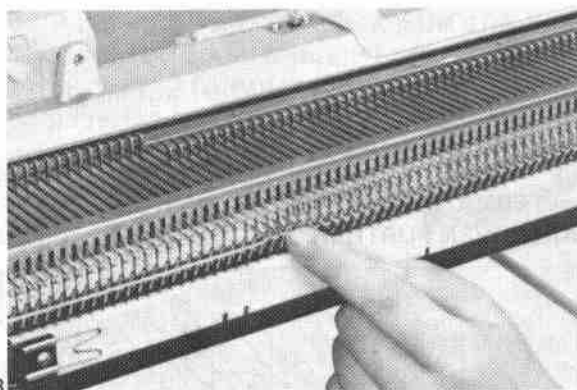

43

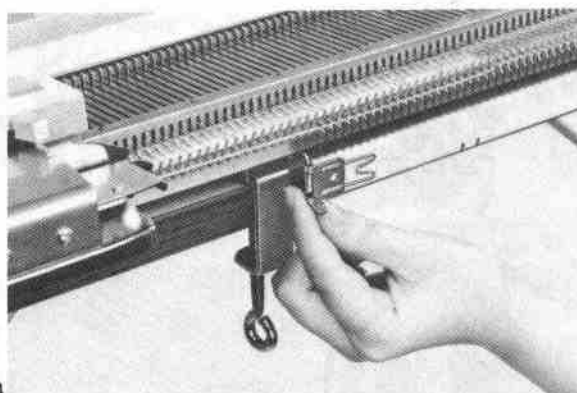

44

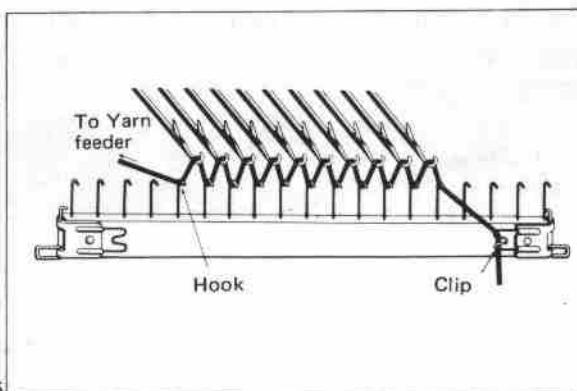

45

- (7) Knit the next row slowly and continue knitting. The cast-on comb can be removed after the first 6 or 8 rows by tilting it backwards. After a few rows, remove the knitting from the machine (i.e., taking the yarn out of the Yarn feeder and move the Carriage across the needles). Practice this cast-on two or three times.

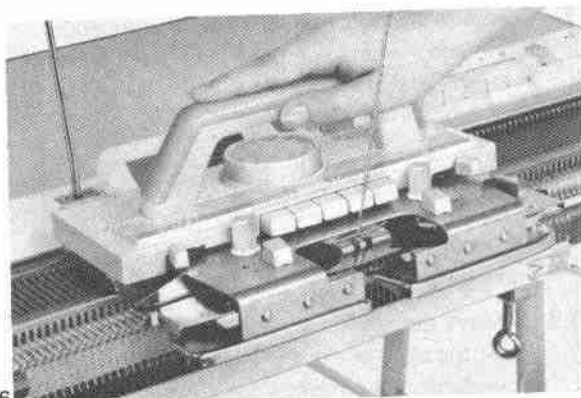

46

YOU ARE NOW ABLE TO DO A QUICK OPEN END CAST-ON. THIS METHOD IS NOT USED WHEN PRODUCING GARMENTS, BUT IS USEFUL FOR KNITTING SWATCH SAMPLES AND EXPERIMENTING.

ALTERNATE METHODS OF CASTING ON ARE GIVEN FURTHER ON.

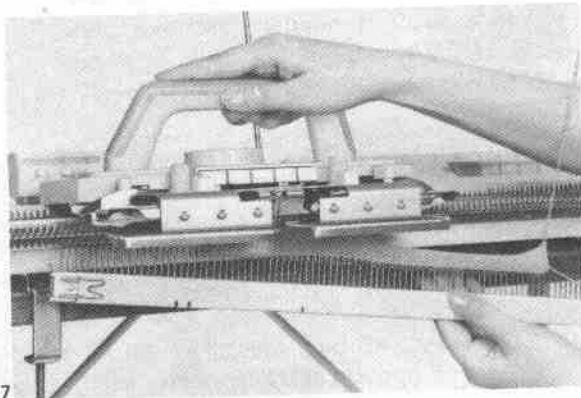

47

The purl side (or wrong side) of the knitted fabric (facing you) looks like right picture. (Fig. 48)

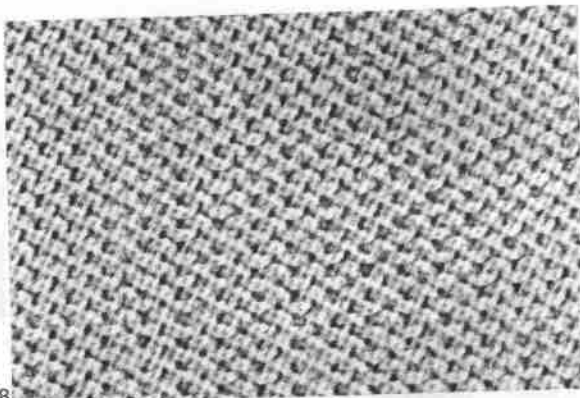

48

The plain side (or right side) of the knitted fabric (away from you) will look like right picture. (Fig. 49)

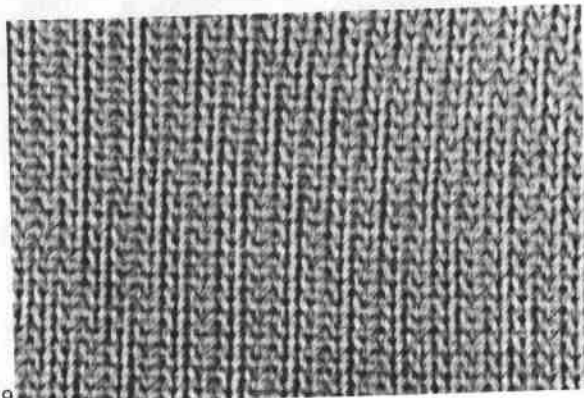

49

IF THE CARRIAGE SHOULD JAM AND HOW TO UNRAVEL A ROW

- (1) Loosen the thumb screws of the sinker plate and remove the sinker plate from the Carriage.
- (2) Holding the handle, lift the carriage up. Then, place it back to the side from where that row commenced.
- (3) With the yarn still in the yarn feeder, return the sinker plate to the carriage and tighten the thumb nuts securely.
- (4) Unravel the last row of knitting. (See below)

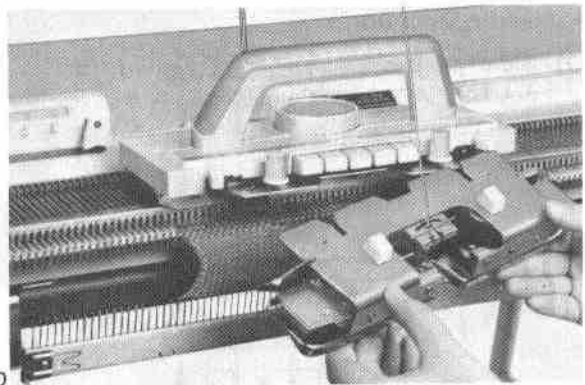

UNRAVELLING A ROW OF KNITTING

- (1) Pull the yarn slightly sideways and up. (See Fig. 51). The stitches will come off the needles and the stitches from the row below will slip onto the needles.
- (2) Continue to pull the yarn sideways and up removing 4 or 5 stitches at a time until you reach the spot where the carriage was jammed.
- (3) Pull the yarn down from the rear (above ball) to take up the slack and to bring the take up spring back into action.
- (4) Ensure that there is no slack from the carriage to the needles by sliding the carriage left and right a few inches (NOT ACROSS NEEDLES IN ACTION). (See Fig. 53.).
- (5) ADJUST THE NUMBERS ON YOUR ROW COUNTER.

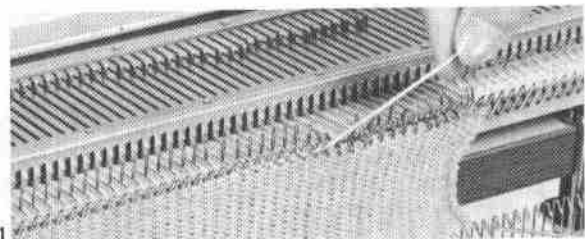

IF YOU FIND IT NECESSARY TO MOVE THE CARRIAGE ACROSS THE NEEDLES IN ACTION WITHOUT KNITTING A ROW then press both PART buttons in at the same time and set the H.C.Ls to III. If any needles have been selected then put them back to B position before going across with the carriage.

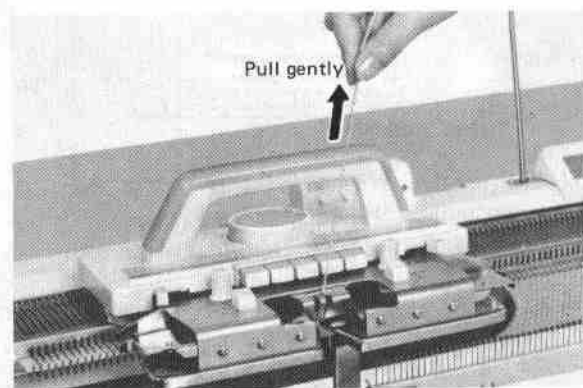
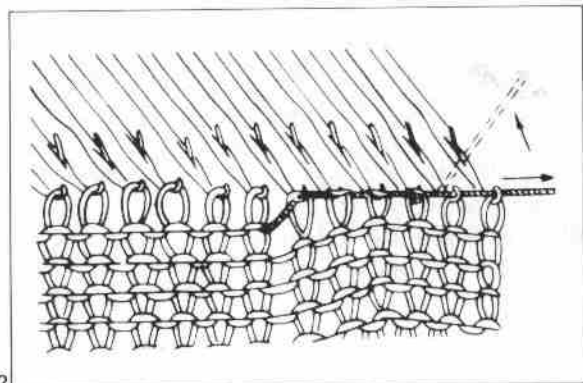

How to use needle selector buttons

• Needle Selection

- (1) Raise the desired number of needles from position "A" to position "B".
- (2) Push down the "1" button.

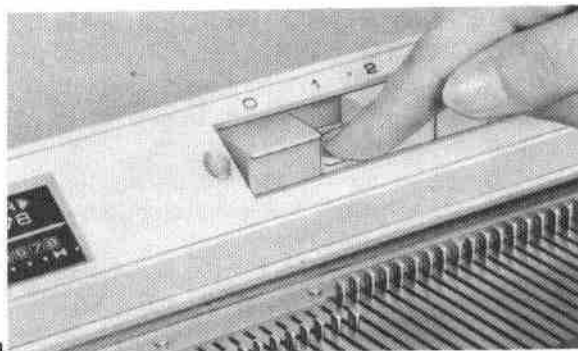

54

- (3) Pull the set-lever to the left as far as it will go, then the corresponding needles will be raised to position "D1".
- (4) Move the carriage with setting for plain knitting. Then all needles will be back to position "B".

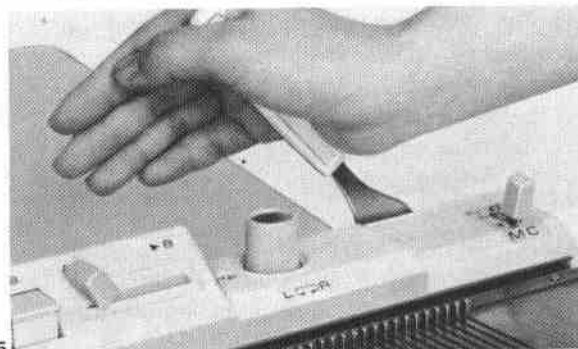

55

- (5) Pull the set lever again so the same needles are brought forward.
- (6) Push down the release button, then the button "1" will be released.

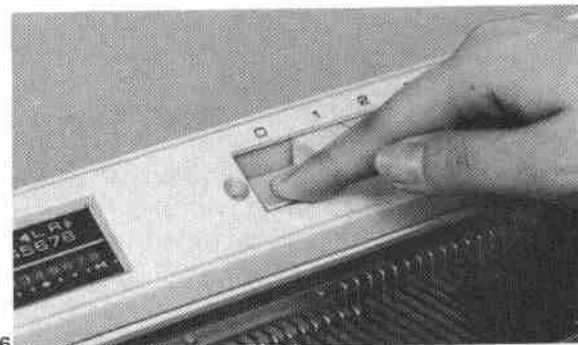

56

- (7) Put the MC change lever to "▼" so that when pulling the set lever, the needles will come to position DII. This operation is used for fair-isle pattern knitting.

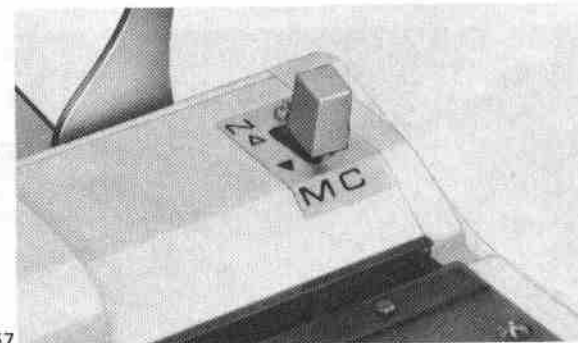

57

• Needle Selector Buttons and Reverse Lever

* There are eight needle selector buttons.

Each button controls each needle group. A combination of pushed down buttons will control the corresponding combination of selected needles.

* The reverse lever has two positions "A" and "B".

* Position "A"

The needles corresponding to pushed down buttons can be selected by pulling the set lever.

* Position "B"

The needles corresponding to unpushed down buttons can be selected by pulling the set lever.

Therefore, by using the reverse lever, needle selection for fair-isle pattern knitting is very simple.

• Slide dial and Slide Indicator

* The slide dial is used for sliding the pattern position and very useful for zigzag patterns and diagonal patterns.

(1) Push down the "1" button, turn the slide dial and set the arrow at 1 on the slide indicator.

Pull the set lever, then the needles on the mark $\triangleright\triangleleft$ will be selected.

(2) Turn the slide dial and set the arrow at 2 on the slide indicator.

Turn the set lever, then the needles on right side of the mark $\triangleright\triangleleft$ will be selected.

The slide direction indicator indicates the direction in which the slide dial is turned.

(3) Relation between the needle selector buttons and the needles are shown in right figure.

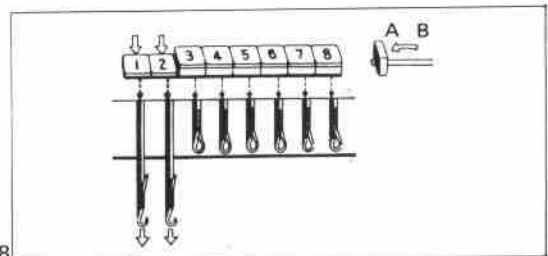

58

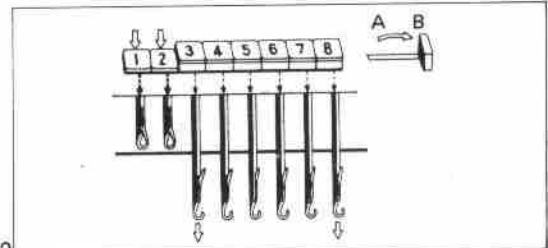

59

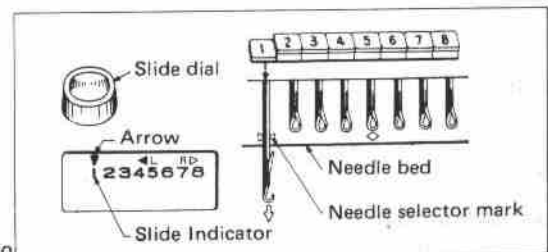

60

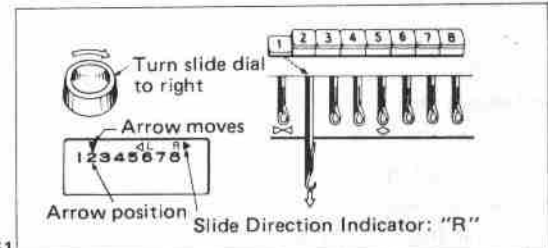

61

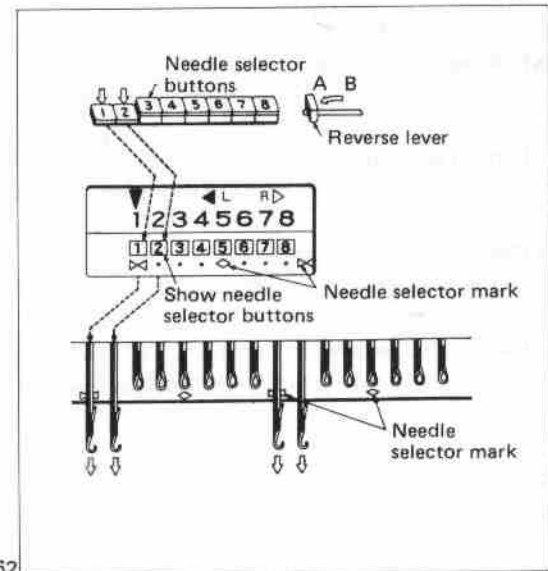

62

Pattern knitting

• How to read the operation tables

* Various knitting patterns are shown in the following pattern knitting tables.

The lower section of the table shows the operating parts of the knitter.

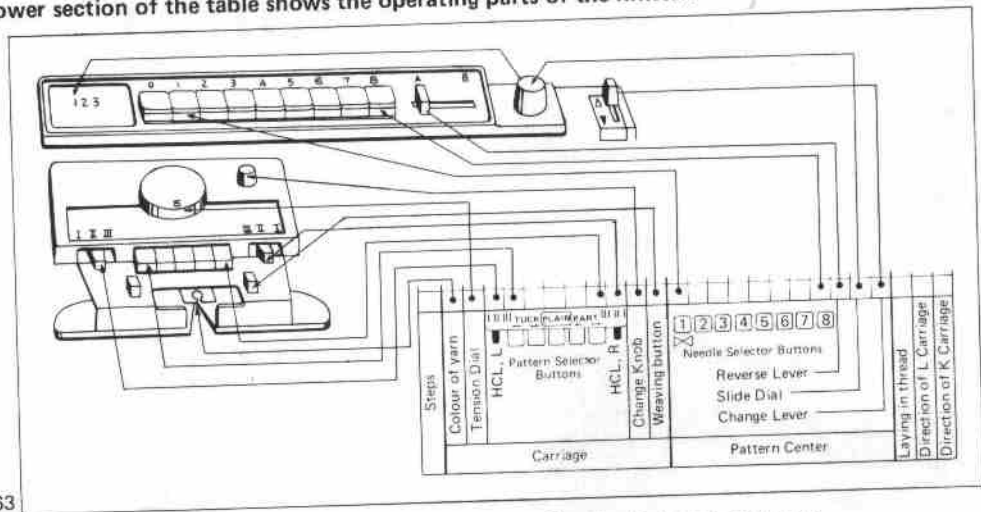

63

• Steps:

Operate the knitter in numerical order.
The required operation in each step is shown in the lateral rows of the table.

• Colour of Yarn:

Shows the colour of yarn in the yarn feeder.
(Right slit)

Main Colour : a

Second Colour : b, c,

• Tension Dial:

Shows the tension No. of the Dial.

The tension number which is indicated in the operation table is the number on the carriage dial that this pattern was knitted in. The tension differs for each type of yarn, and therefore this number can only be used as a guide.

• Holding Cam Levers:

Shift the holding cam levers right and left sides to the marked positions: I, II, or III.

• Pattern selector buttons:

Press the cam button corresponding to the designated mark.

• Change knob:

Turn this knob to corresponding position of the marks: N, W.T or MC.

• Buttons for weaving Pattern:

Place both buttons to corresponding position of the marks.

Needle Selector Buttons

① ~ ⑧ :

Shows the button to be pushed down and operation of the set lever.

- ⑤ means pushing down button "5" and operation of the set lever.
- means operation of the set lever without repushing down of button.

• Reverse lever:

Shift the reverse lever to the corresponding mark.

• Slide dial

Turn the slide dial to set the scale at this figure.

• Change lever:

Shift this lever to the marked position.

• Laying-in thread:

Shows the colour of the laying-in Thread.

• Direction of L-Carriage:

Slide the L-carriage to the marked direction.

• Direction of K-Carriage:

Slide the K-carriage to the marked direction. The mark of "→" means one-way travel and the mark of "↻" means the round travel of the carriage. Before knitting, position the K-carriage at the right side of the knitting.

1. Pull-up stitch pattern

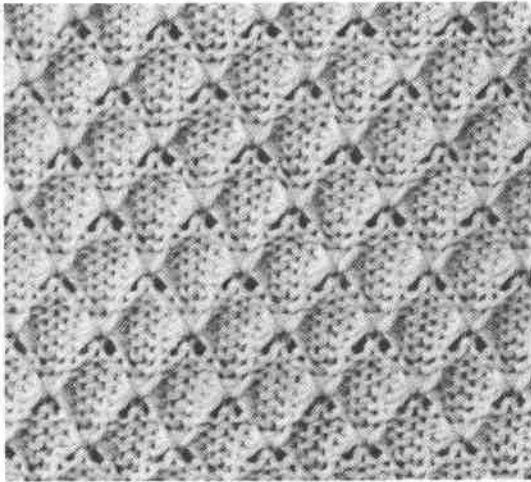

64

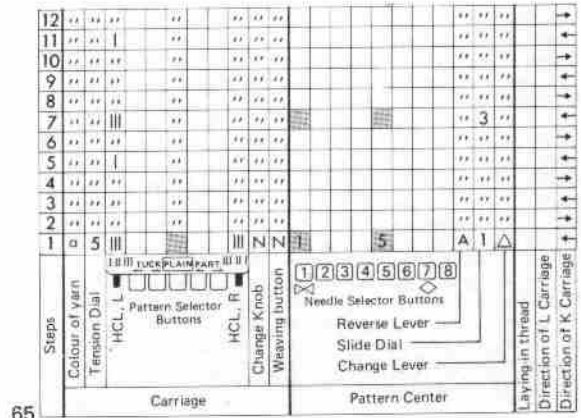

How to knit the Pull-up stitch pattern

It is not necessary to change the yarn, pattern selector button and reverse lever.
Knit several rows of plain knitting and rest the carriage on the right side of the needle bed.

Step 1.

- colour of yarn : main colour
- tension dial : 5
- holding cam levers : left III, right III
- pattern selector buttons : plain
- change knob : Set the knob at the position of "N".
- buttons for weaving pattern : Set both buttons at the position of "N".
- needle selector buttons : 1, 5
- reverse lever : A
- slide dial : 1
- change lever : Set the lever at the mark of " Δ ".

After setting as above, pull the set lever and move the carriage from right to left.

Step 2.

Move the carriage to right.

Step 3.

Move the carriage to left.

Step 4.

Move the carriage to right.

Step 5.

Change the left holding cam lever from "III" to "I", and move the carriage to left.

Step 6.

Move the carriage to right.

Step 7.

Turn the slide dial and set the arrow to 3 on the slide indicator.

Pull the set lever.

Change the left holding cam lever from "I" to "III".

Move the carriage to left.

Step 8.

Move the carriage to right.

Step 9.

Move the carriage to left.

Step 10.

Move the carriage to right.

Step 11.

Change the left holding cam lever from "III" to "I", and move the carriage to left.

Step 12.

Move the carriage to right.

Repeat steps (1)~(12).

2. Open stitch pattern

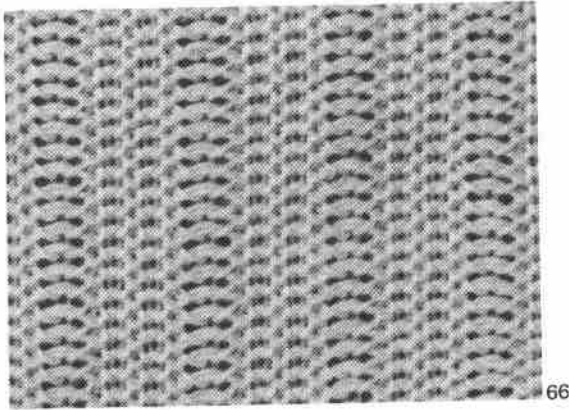

66

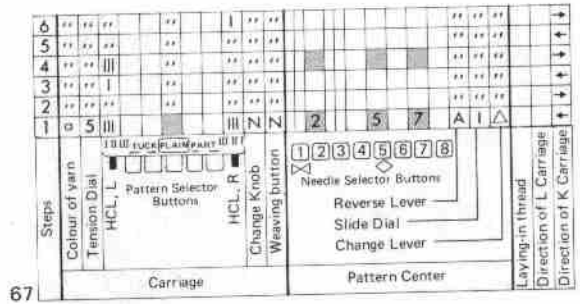

67

Open stitch patterns are worked with a certain number of needles placed in the non-operating position (A). In this condition you can work unique and very interesting pattern stitches by using pull-up stitches or tuck stitches in combination.

Needle arrangement:

Push back the needles which correspond with needle selector buttons No. 1 and 3 to position A (non-working position).

3. Tuck stitch pattern

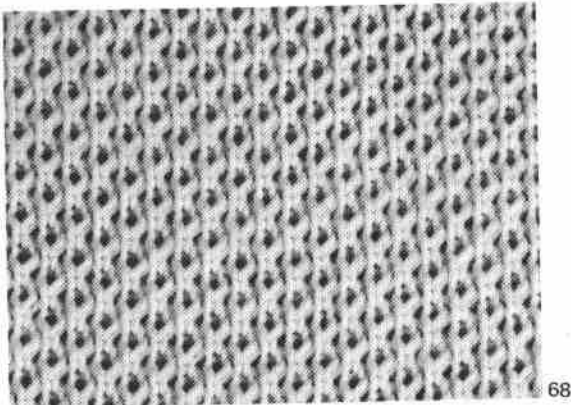

68

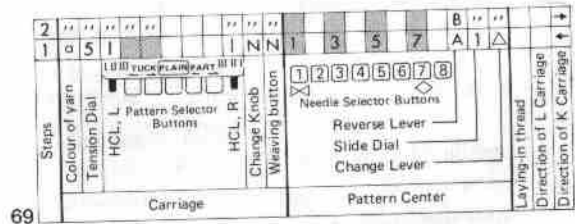

69

6. Fair-isle pattern (1)
(Multi-colour pattern)

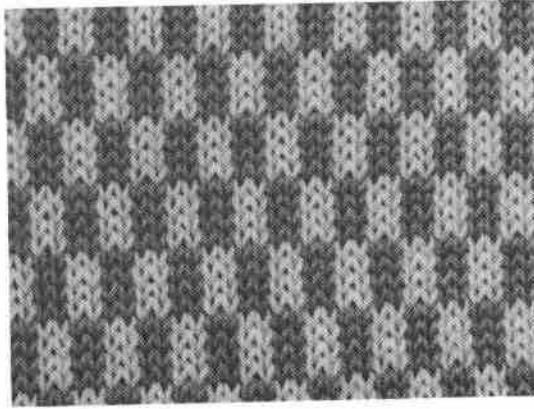

74

Steps	Colour of yarn	Tension Dial	HCL, L	Pattern Selector Buttons	HCL, R	Change Knob	Weaving button	Needle Selector Buttons	Reverse Lever	Slide Dial	Change Lever	Laying in thread	Direction of L Carriage	Direction of K Carriage
8	** ** *			** ** *	** ** *									
7	** ** *			** ** *	** ** *									
6	** ** *			** ** *	** ** *									
5	** ** *			** ** *	** ** *							B	** ** *	
4	** ** *			** ** *	** ** *								** ** *	
3	** ** *			** ** *	** ** *								** ** *	
2	** ** *			** ** *	** ** *								** ** *	
1	a	7	I		I	W	N	1 2 3 4 5 6				A	1	b

75

Operation steps

- (1) Knit several rows with plain stitch and stop the carriage at the left end of the needle bed.
- (2) Set the change knob on the carriage to the position "MC", and move the carriage to the right so that the needles will come onto the position DI.
- (3) Push both PART buttons.
- (4) Shift the MC change lever to the mark of ▼.
- (5) Thread the second colour yarn (b) into the yarn tension unit.
- (6) According to the operation table, push the needle selector buttons Nos. 1, 2, 5 and 6, then pull the set lever.
- (7) Thread the second colour yarn (b) into the left yarn guide as shown in the photograph, and move the carriage to the left. (Please check if all latches are open before commencing each row)

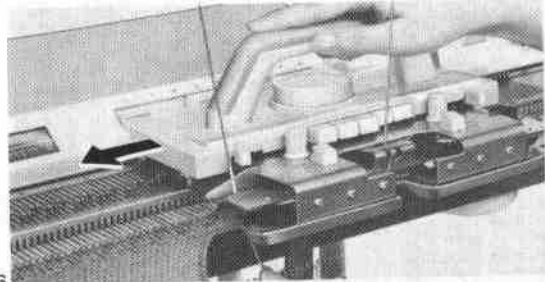

76

- (8) Pull the set lever. In knitting the second row, it is necessary to remove the second colour yarn (b) from the left yarn guide and place it in the right yarn guide. (This must be repeated every row when knitting the fair-isle pattern.)
Then move the carriage to the right.

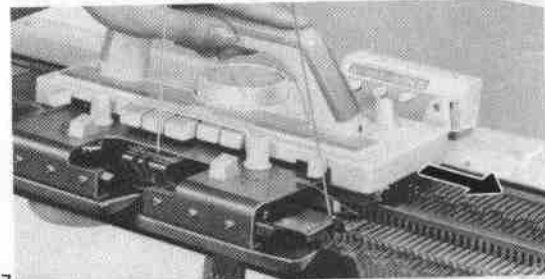

77

- (9) Continue the knitting according to the operation table.
* If an end needle on the same side of the carriage is not forwarded to DI1 position, please bring it to DI1 position by hand.

7. Fair-isle pattern (2)

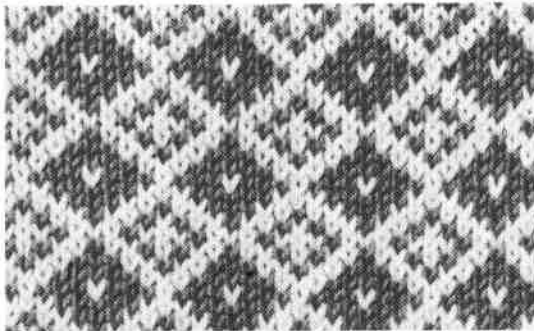

78 79

8	**	**	**	**	**	**	**	**	**	4	5	6	**	**	**	**	→
7	**	**	**	**	**	**	**	**	**	3	4	5	6	7	**	**	→
6	**	**	**	**	**	**	**	**	**	2	3	4	5	6	7	8	→
5	**	**	**	**	**	**	**	**	**	2	3	4	5	6	7	8	→
4	**	**	**	**	**	**	**	**	**	2	3	4	5	6	7	8	→
3	**	**	**	**	**	**	**	**	**	3	4	5	6	7	**	**	→
2	**	**	**	**	**	**	**	**	**	3	4	5	6	7	**	**	→
1	□	7	1							4	5				B	1	↓

Steps

Colour of yarn

Tension Dial

HCL, L

Pattern Selector Buttons

HCL, R

Change Knob

Weaving button

Carriage

1 2 3 4 5 6 7 8

Needle Selector Buttons

Reverse Lever

Slide Dial

Change Lever

Pattern Center

Laying-in thread

Direction of L Carriage

Direction of K Carriage

8. Fair-isle pattern (3)

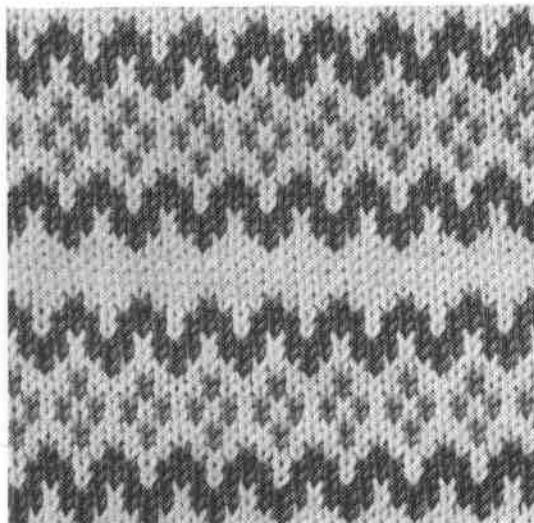

80

22	**	**	**	**	**	**	**	**	**	**	**	**	**	**	**	**	→
21	**	**	**	**	**	**	**	**	**	**	**	**	**	**	**	**	→
20	**	**	**	**	**	**	**	**	**	**	**	**	**	**	**	**	→
19	**	**	**	**	**	**	**	**	**	**	**	**	**	**	**	**	→
18	**	**	**	**	**	**	**	**	**	4	8	**	**	**	**	**	→
17	**	**	**	**	**	**	**	**	**	1	3	4	5	7	8	**	→
16	**	**	**	**	**	**	**	**	**	1	3	5	7	**	**	**	→
15	**	**	**	**	**	**	**	**	**	1	3	5	7	**	**	**	→
14	**	**	**	**	**	**	**	**	**	2	6	**	**	**	**	b	→
13	**	**	**	**	**	**	**	**	**	2	6	**	**	**	**	**	→
12	**	**	**	**	**	**	**	**	**	4	8	**	**	**	**	**	→
11	**	**	**	**	**	**	**	**	**	4	8	**	**	**	**	**	→
10	**	**	**	**	**	**	**	**	**	1	3	5	7	**	**	**	→
9	**	**	**	**	**	**	**	**	**	1	3	5	7	**	**	**	→
8	**	**	**	**	**	**	**	**	**	2	6	**	**	**	**	**	→
7	**	**	**	**	**	**	**	**	**	2	6	**	**	**	**	**	→
6	**	**	**	**	**	**	**	**	**	2	6	**	**	**	**	**	→
5	**	**	**	**	**	**	**	**	**	2	6	**	**	**	**	**	→
4	**	**	**	**	**	**	**	**	**	1	2	3	5	6	7	**	→
3	**	**	**	**	**	**	**	**	**	1	2	3	5	6	7	**	→
2	**	**	**	**	**	**	**	**	**	1	3	5	7	**	**	**	→
1	□	6	1							4	8	1	↓	b		→	

Steps

Colour of yarn

Tension Dial

HCL, L

Pattern Selector Buttons

HCL, R

Change Knob

Weaving button

Carriage

1 2 3 4 5 6 7 8

Needle Selector Buttons

Reverse Lever

Slide Dial

Change Lever

Pattern Center

Laying-in thread

Direction of L Carriage

Direction of K Carriage

81

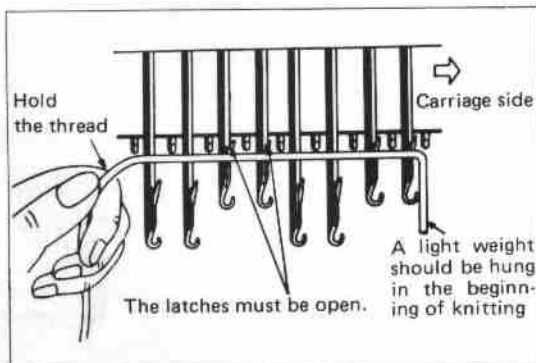

82

*When using more than 2 colours, the additional colours should be kept in a bowl on the floor beside the machine. An extra colour can then be knitted by laying the yarn by hand over the needles. (See Fig. 82). Making sure that all the latches are open.

*A slight tension should be put on the yarn as it slides between the fingers.

*This should be practiced on a test sample of knitting before commencing the garment.

9. Skip stitch pattern

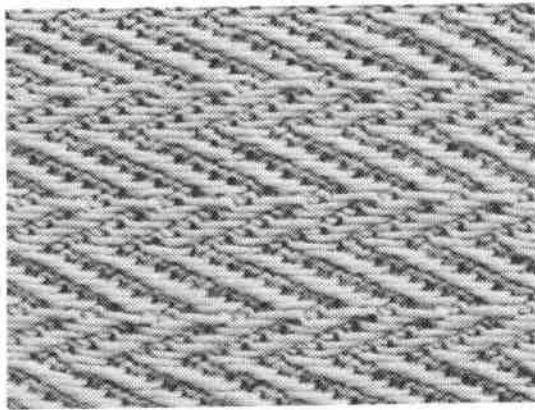

83

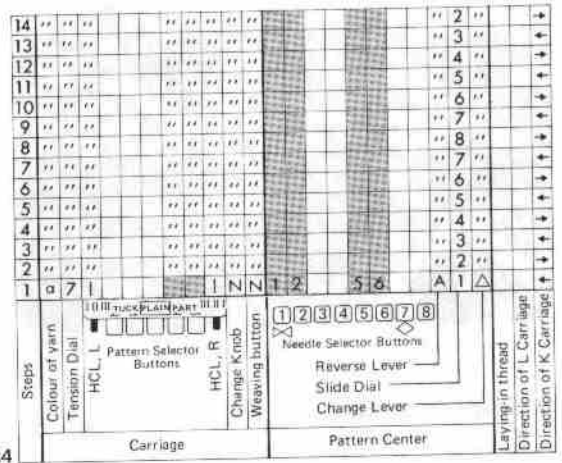

84

10. Weaving pattern (1)

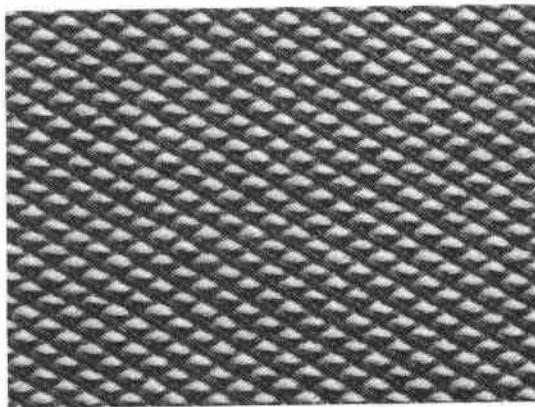

85

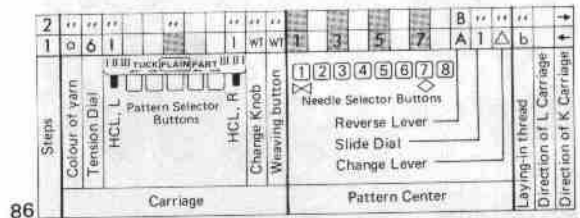

86

*The best woven material effect is obtained when the yarn you are using to knit is very thin (2 or 3ply) and the weaving yarn is thick (Double or triple knit). You can also use fancy yarns for the weaving yarn.

1. Set the tension one or two sizes larger than plain knitting.
2. Cam button setting is the same as Plain knitting.
3. Set the Change knob and Weaving buttons to "W.T".

*To thread the weaving yarn (b) into the yarn guide is the same manner as for fair-isle knitting.

How to use the L Carriage

1. Remove the L Carriage from the Carrying case.

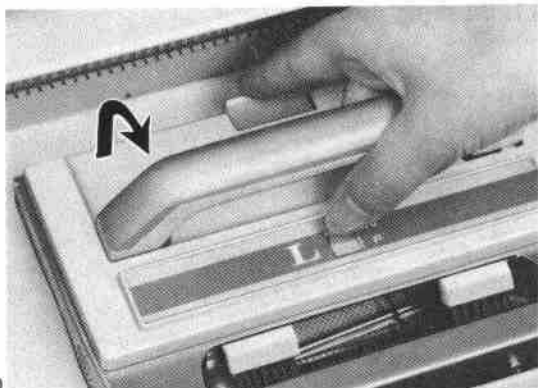

90

2. Remove the Extension rails from the Carrying case.

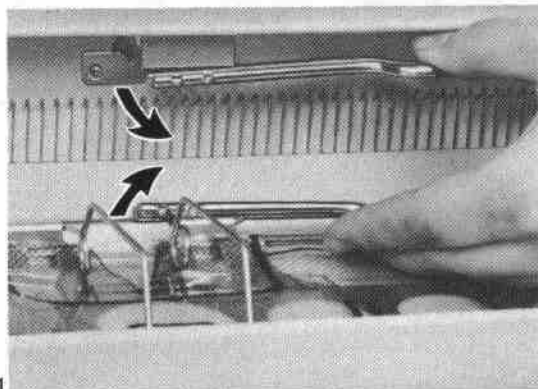

91

3. Insert the Extension rail into the holes (A) and (B) at the edge of the machine.

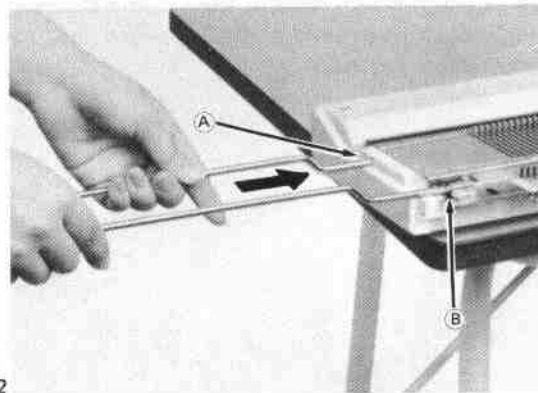

92

4. It is recommended that the wax block is used when knitting any synthetic yarn with the L Carriage.

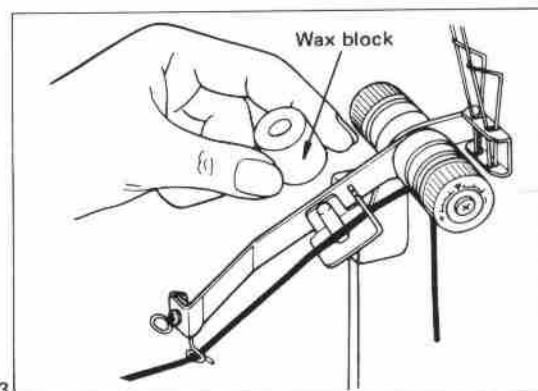

93

5. Knit several rows in plain stitch, and hang the claw weights onto the Cast-on comb.

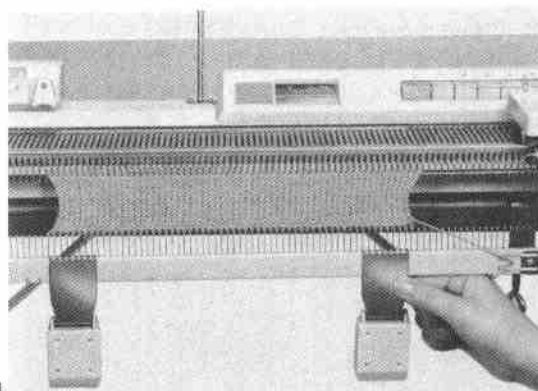

94

6. It is important therefore that no two (or more) adjacent needles are brought forward together.

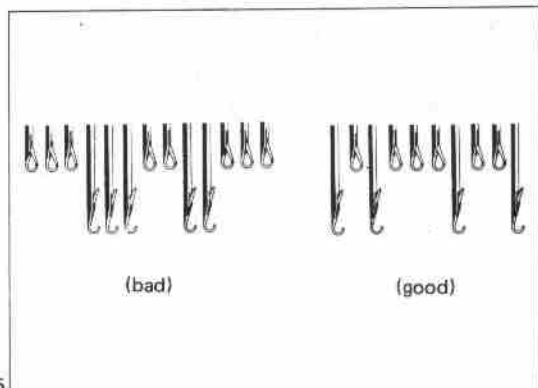

95

7. In the event that an end needle is brought forward it should be pushed back by hand to position B. You can do this without fear of the stitch dropping.

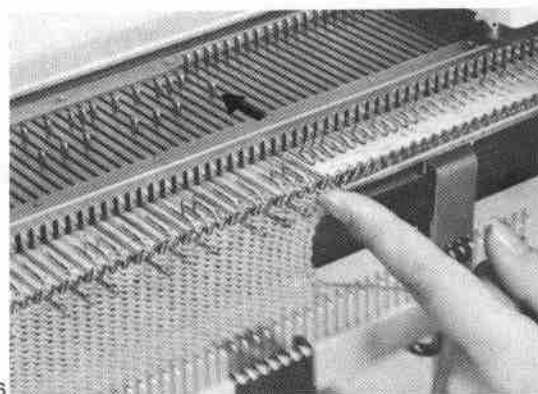

96

8. FITTING THE L CARRIAGE

Make sure that all needles which are not being used are in position "A" before fitting L carriage to machine.

Put the L carriage on the Extension rail correctly, and slide into the rail of needle bed.

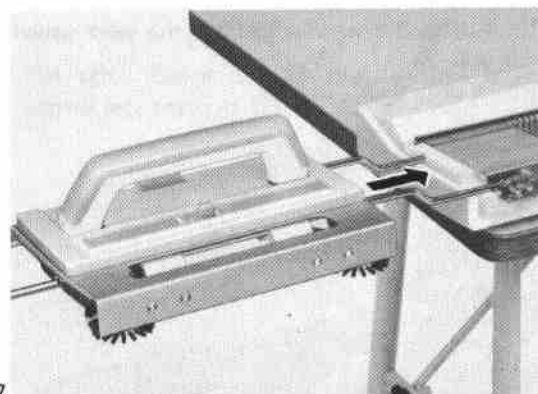

97

9. Please move the L Carriage slowly.
IF THE L CARRIAGE SHOULD JAM
DURING KNITTING REFER TO PAGE
53 TO RELEASE IT.

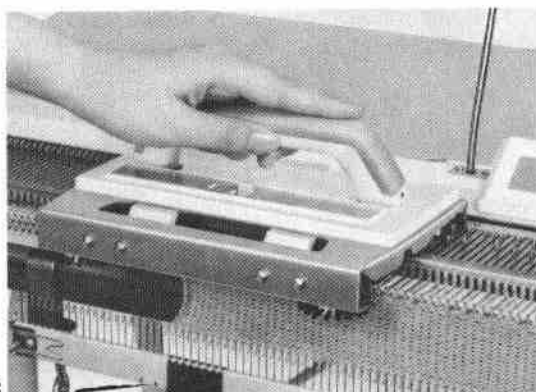

98

10. To unlock the L carriage, press the Release
button at the back and release it from under
the rail.

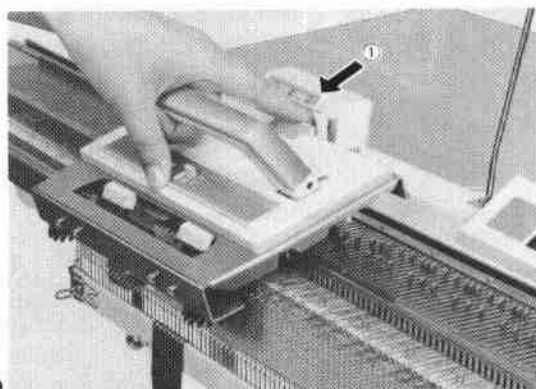

99

11. To rest the L carriage on the Extension rail,
place it firmly in position as shown.

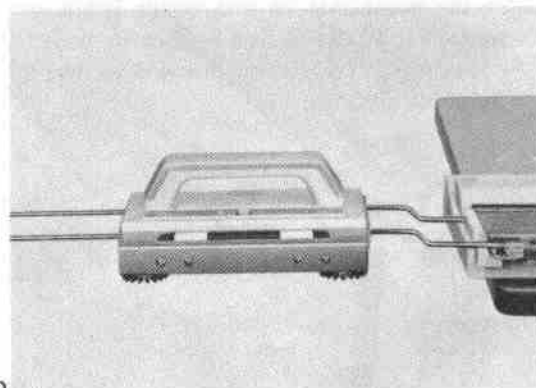

100

12. Adjust the tension dial for the yarn which
you use.

Suggested Tension No. for lace knitting

Yarn	Tension No.
Fine (ex. 2 ply)	3 ~ 4
Medium fine (ex. 3 ply)	4 ~ 5
Medium (ex. 4 ply)	5 ~ 6
Lace yarn	4 ~ 5

Lace pattern and Fine-lace pattern

12. Lace pattern (1)

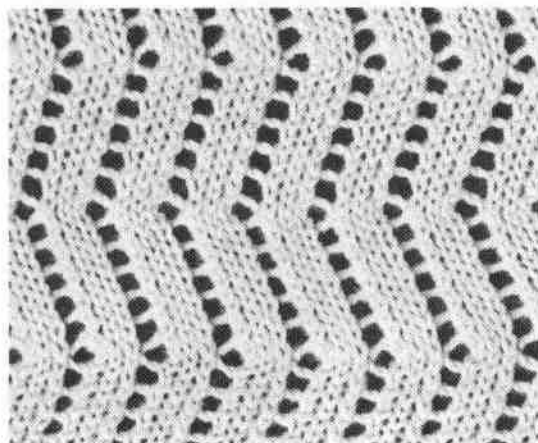

101 102

Fine-lace pattern (1)

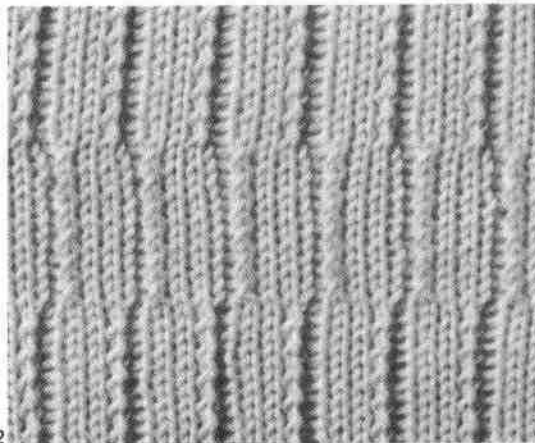

This is the most basic lace pattern.

Step 1:

Push down needle selector buttons 1 and 5 and turn set lever.

It is not necessary to reset the slide dial. (If the end needles are brought forward to position "D", push them back with fingers.)

Move the L carriage from left to right so that the all stitches on the selected needles will be transferred to the right adjacent needles, and selected needles will return to B position. Then you can pass the L carriage back to left side without working.

Knit two rows by the K carriage.

Steps: 2 – 6

Exactly same as Step 1.

Step 7:

Pass the L carriage to right without working. Turn the set lever.

Move the L carriage from right to left to transfer the stitches.

Knit two rows by the K carriage.

Steps: 8 – 12

Exactly same as Step 7.

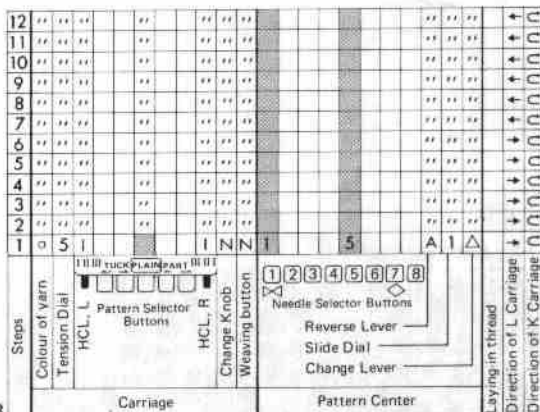

The lace change lever is on the L carriage, and it has two positions.

N: This is for normal lace patterns.

F: This is for fine-lace patterns.

When knitting the fine-lace pattern, shift the lace change lever to "F" and set the tension dial on the K carriage one number larger than normal lace.

The other operations are exactly same as for normal lace patterns.

Plating yarn knitting

PLATING YARN KNITTING

With the plating yarn feeder it is possible to use two yarns to knit a reversible fabric with different colour on the front and back side.

- (1) Thread two yarns (different colour) into the yarn tension unit, and hang them on the yarn clip.
- (2) Thread the main yarn into the main yarn feeder (right slit). Knit several rows with plain stitch.
- (3) Thread the plating yarn into the plating yarn feeder (left slit). Continue the knitting with two yarns in yarn feeder.

The main yarn will appear on the front side of fabric (away from you) and plating yarn appears on the back side of fabric (facing you). Hang the claw weight on both ends of the fabric.

By replacing the main yarn with the plating yarn, the colour of the fabric will be changed.

Suggested Tension No. is as follows

Main yarn	Plating yarn	Tension No.
Medium fine (ex 3 ply)	Medium fine (ex. 3 ply)	9 – 10
Medium fine (ex. 3 ply)	Fine (ex. 2ply)	9 – 10
Fine (ex. 2 ply)	Medium fine (ex. 3 ply)	9 – 10
Fine (ex. 2 ply)	Fine (ex. 2 ply)	7 – 9

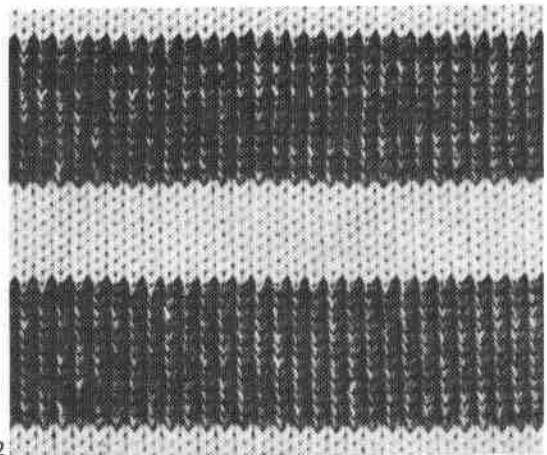

112

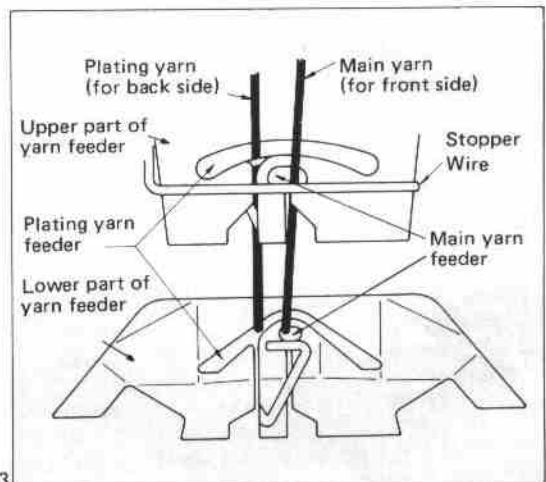

113

Intarsia knitting

INTARSIA KNITTING

There are no traversing yarns at the back. And you can knit multi-colour of yarns in one row.

We recommend you to make the diagram for intarsia design before knitting.

According to the diagram, the example is knitted with two different colours of yarn.



114

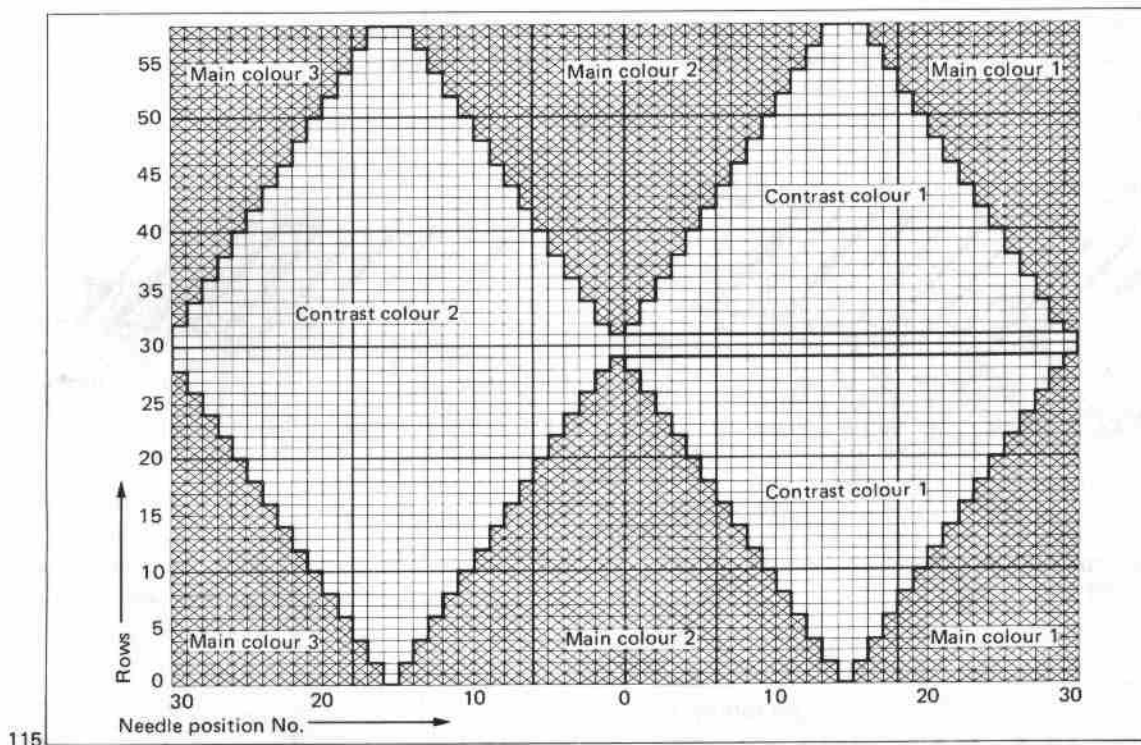

115

- (1) Cast on with plain stitch, and stop the carriage at the left end of the needle bed.
- (2) Set the change knob on the carriage to MC position, and move the carriage to right. The knitting needles with latches opened will come onto the position DI after passing the carriage.

*Please check that all latches are open.

If not, open it by hand otherwise the stitch would be dropped.

- (3) Push both PART buttons.
- (4) Remove the main yarn from the yarn tension unit, and place the main yarn at your feet.

*Prepare the yarns according to the pattern (not number of colours), for instance, 3 balls of main colour and 2 balls of contrast colour for above diagram.

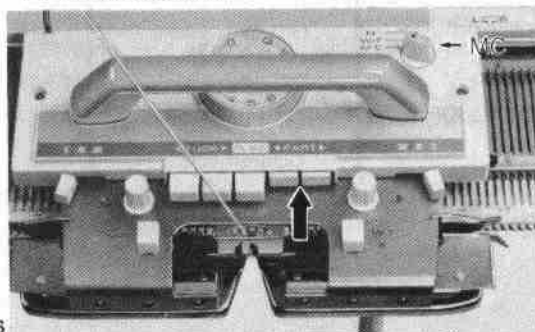

116

For the first row

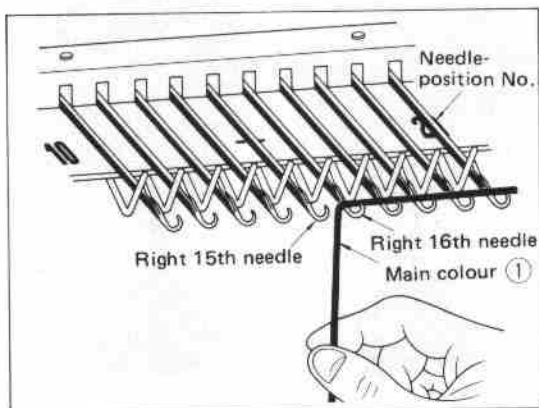

(5) Lay the main colour yarn (1) over the needles, and let the yarn hang down between the 15th and 16th needle. (See above illustration)

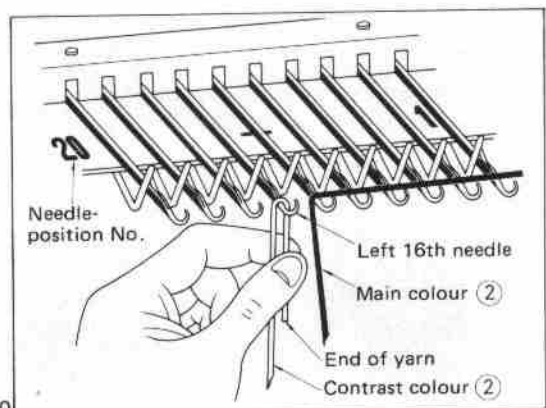

(8) Hang the contrast colour yarn (2) on the left 16th needle.

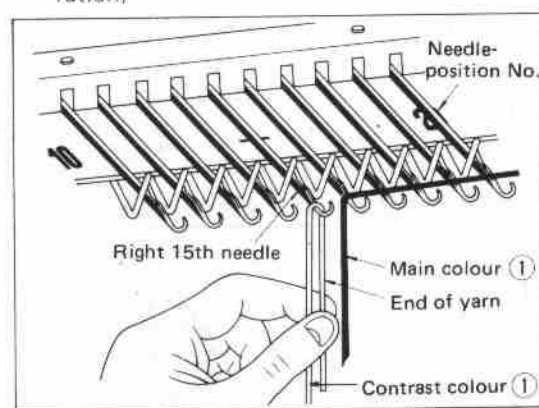

(6) Hang the contrast colour yarn (1) on the right 15th needle.

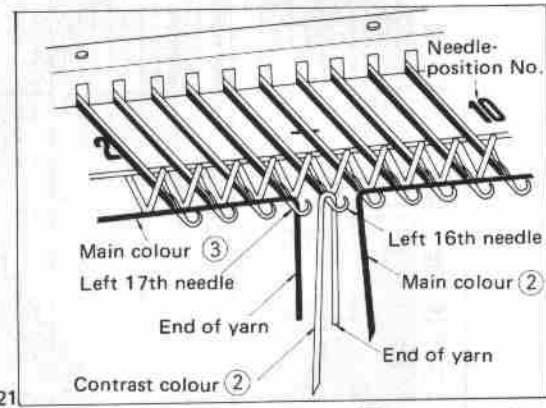

(9) Lay the main colour yarn (3) on the needles (from left 17th needle to the end of the fabric).

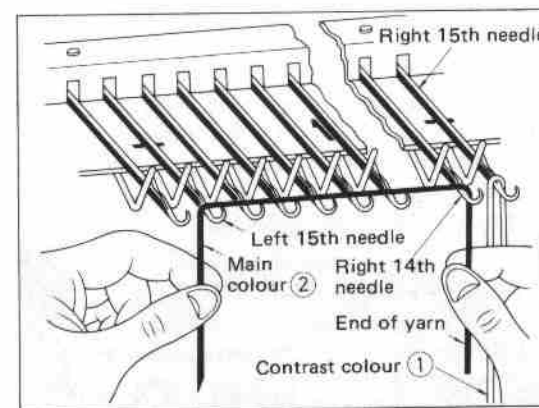

(7) Lay the main colour yarn (2) on the needles (from right 14th needle to left 15th needle) as illustrated.

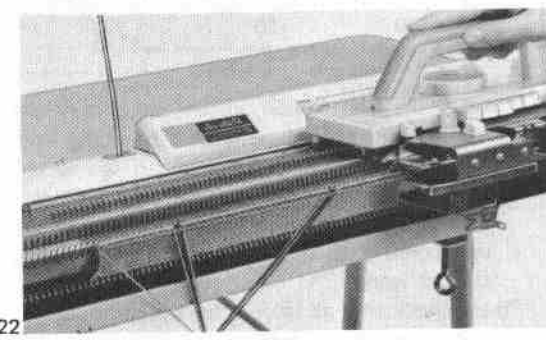

(10) Pull both ends of main and contrast yarn gently, and move the carriage to the left.

For the second row

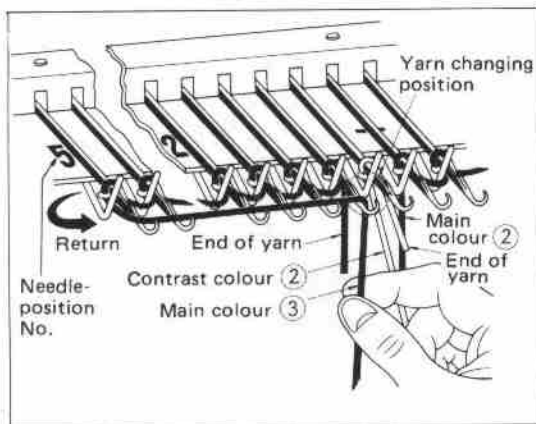

123 125

(11) Lay the main colour yarn (3) on the same needles as the step (9).

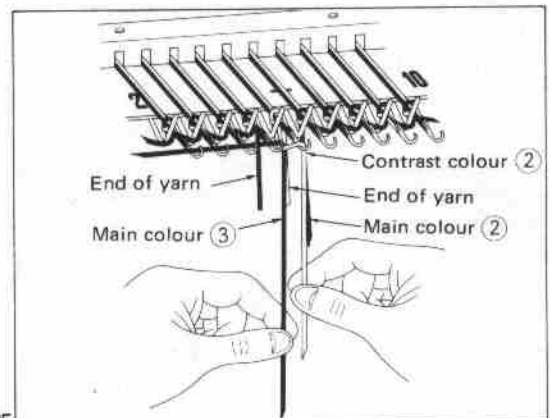

(13) Then, hang the contrast colour yarn (2) on the left 16th needle.

(14) Cross the yarns at every yarn changing position, and lay the yarn over the needles.

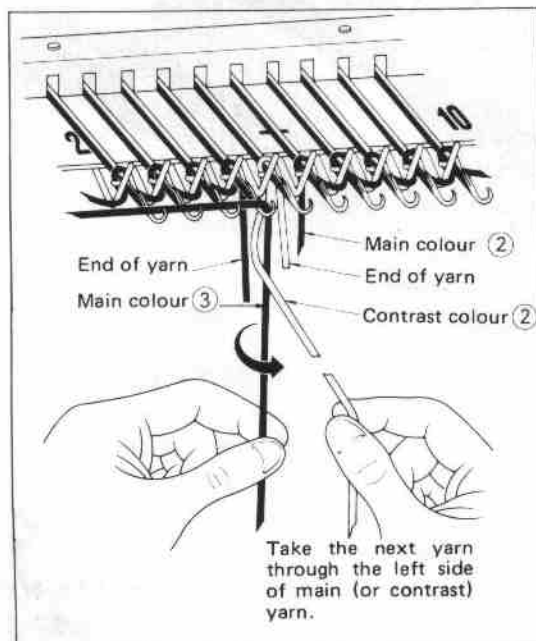

124 126

(12) Cross the main and contrast yarns at the yarn changing position as illustrated.

*When the carriage will move from left to right, cross the yarns as illustrated above.

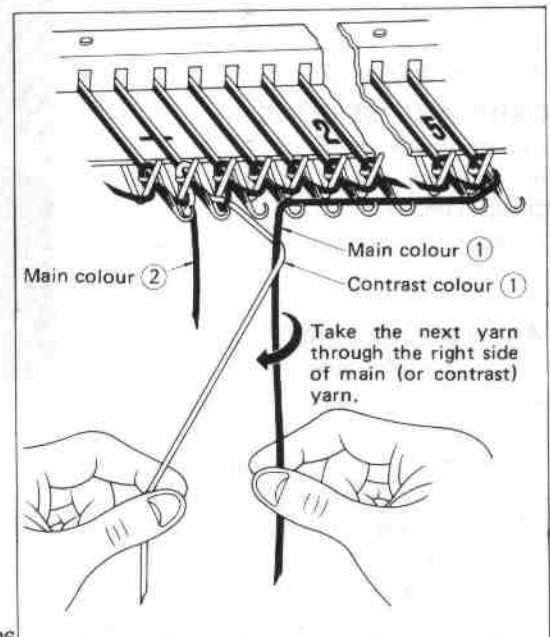

Crossing yarn at every yarn changing position is to avoid making a hole on the fabric.

*When the carriage will move from right to left, cross the yarns as illustrated above.

*The above illustration is explaining for the third row of design diagram.

Now let's knit a plain hem

BEFORE CONTINUING: LTE'S LOOK HOW A STITCH IS FORMED.

- (1) The stitch is on the needle which is behind the gate pegs.
- (2) The carriage brings the needle forward by pushing the needle butt.
- (3) The stitch pushes the latch back and falls behind it.
- (4) The new thread (from the yarn feeder on the carriage) is laid into the needle hook.
- (5) The carriage brings the needle back and so doing the previous stitch gets pushed forward again — this time right over the latch (by-passing the hook).
- (6) The newly laid thread gets pulled in to form another stitch.

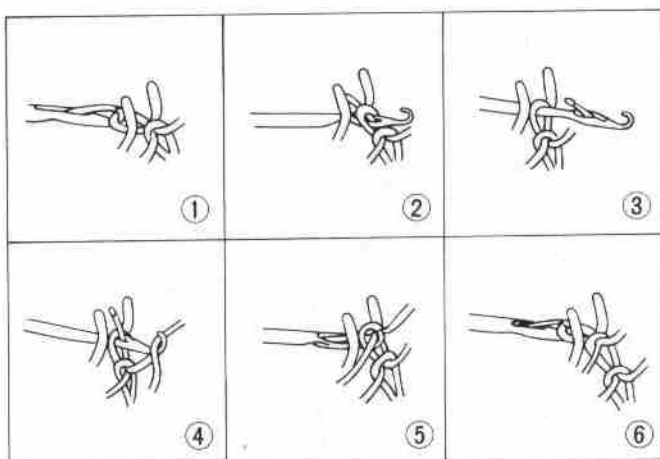

127

LET'S KNIT A PLAIN HEM.

Bring forward the required number of needles (evenly divided on either side of the centre '0') to working position B. Slide the carriage across these needles to straighten the needle butts.

CARRIAGE SETTING

Cam Button—PLAIN.

H.C.Ls.—Both on I.

Change knob N.

Tension Dial—7 (3-ply wool). Carriage on the right.

MACHINE SETTING

Thread the yarn tension unit using waste wool (or any contrast colour yarn). Cast on (as previously shown using the cast on comb) and knit 8 or 10 rows plain. Remove the cast on comb from the knitting.

- (1) Tighten the tension by two numbers (i.e., 5)
- (2) Take waste wool out of the yarn feeder and re-thread the machine with the wool to be used.
- (3) Set row counter back to '0'.
- (4) When the yarn is threaded into the carriage hold it below with one hand and knit across with the other.
- (5) Knit approx. 20 or 30 rows or as required for double the depth of hem.
- (6) Using the single eyed transfer tool open the latches of the needles as shown (refers to Fig. 128).

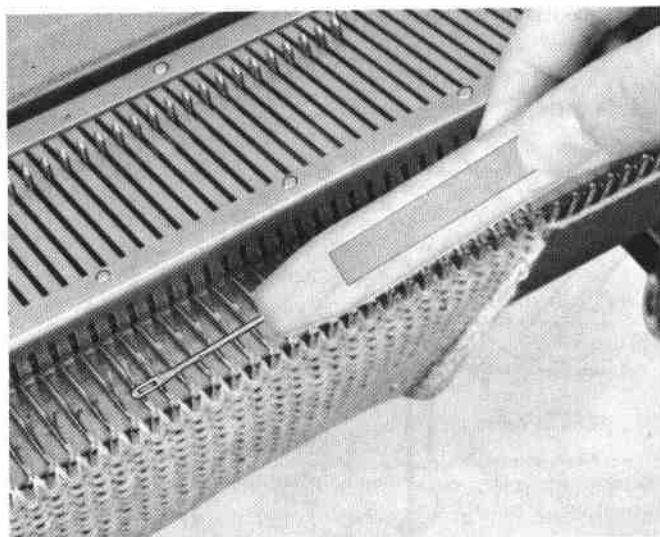

128

TURNING THE HEM

Pick up the first stitch (away from carriage) of the first row where it meets the contrast colour row. (N.B. DO NOT PICK UP THE CONTRAST COLOUR STITCH). Insert the transfer tool into this stitch and lay the tool over the hook of the needle.

- (2) Hold the work against the machine with your left hand and pull the transfer tool back and up with your right. This brings the needle forward to E Position and slips the stitch from the tool onto the needle. (N. B. If you intend to do the next row in a pattern stitch that required the needles to be in B Position—then do not pull the transfer tool back, but simply raise it upwards so that the stitch falls onto the needle.

Make sure that the needle does not come forward enough for the two stitches to fall behind the latch).

- (3) Continue raising the first row of stitches in this manner until all the needles have two stitches on them.
- (4) Reset the tension dial to 7 and take up any slack in the wool from the knitting to the carriage.
- (5) Knit 1 row (closing Hem), reset to main tension and continue knitting garment.

REMOVING THE WASTE WOOL

Once the garment has progressed few inches you can remove the waste wool by breaking the end stitch of the row joining the knitting and pulling the loose thread at the other end of this row.

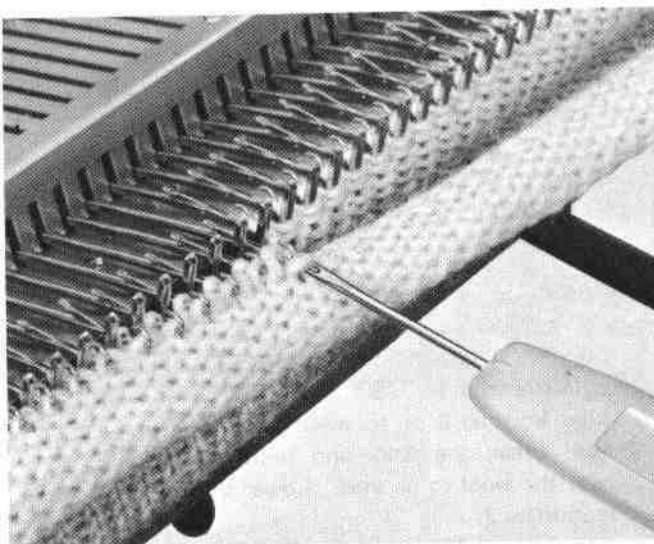

129

Now lets try an elastic hem (i.e. continental or double 'rib')

Using the 1/1 needle pusher, bring forward the required number of needles to B position. (Bring every alternate needles forward to B position). The other needles must be in A position. And move the carriage across and back to align all the alternate needles in position B.

- (1) Thread up and cast on with waste wool as before. (When the comb is dropped it should catch the first row as illustrated in No. 130).
- (2) After knitting 8 or 10 rows of waste wool break the wool and re-thread with the wool to be used. Lower the tension by 2.
- (3) Knit approx. 40 or 50 rows. (See Figs. 131 and 132).
- (4) Bring forward all the empty needles from Position A to Position B, by hand and make sure that all the latches are open.
- (5) Using the one eyed transfer tool and starting from the end opposite the carriage pick up each stitch from the first row (where it joins the waste wool) and raise these onto the empty needles. (See Fig. 133).

(NOTE: As explained under 'plain hem' when raising these stitches the needles can be brought forward to E Position to ensure that the stitches do not drop off—or they can be left in B Position).

- (6) Return the Tension dial to main tension and after knitting a few inches the waste wool can be removed.

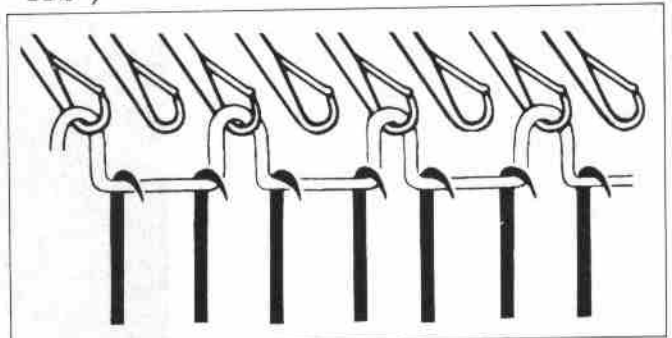

130

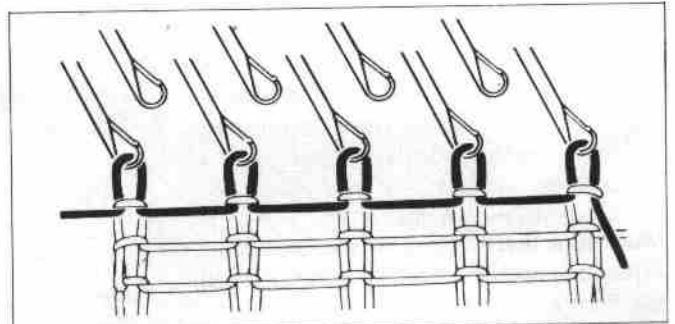

131

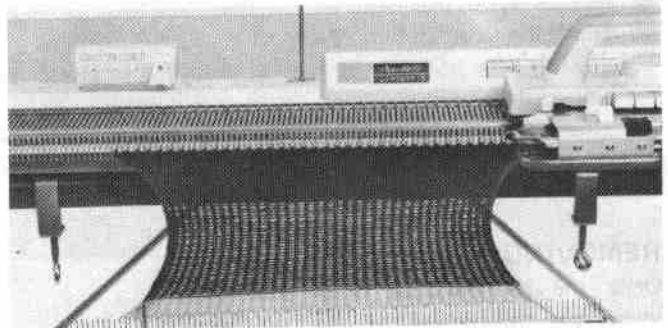

132

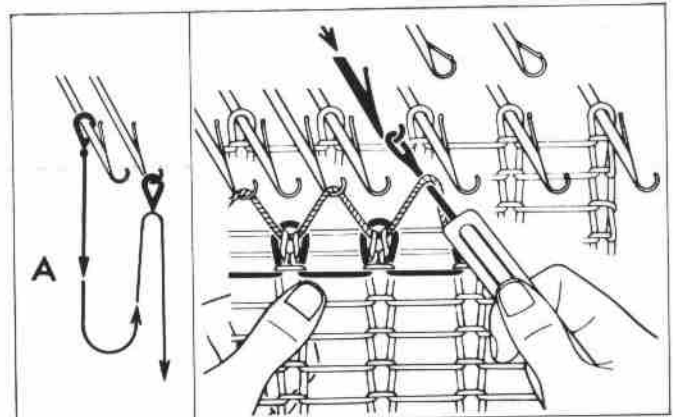

133

THE FINISHED "DOUBLE RIB" SHOULD LOOK LIKE THIS

(See Fig. 134)

MANY variations of this elastic rib can be made for cuffs and hems. One of the more popular is the 2 X 1 Double Hem—the instructions of which are given here.

- (1) Bring forward the required number of needles to B Position and push back every third needle to Position A (out of action). (See Fig. 135).
- (2) Follow the previous instructions for the 'continental rib', but when raising the first row of stitches (adjoining the waste wool)—put them onto the adjacent two needles to the left (See Fig. 136).



134

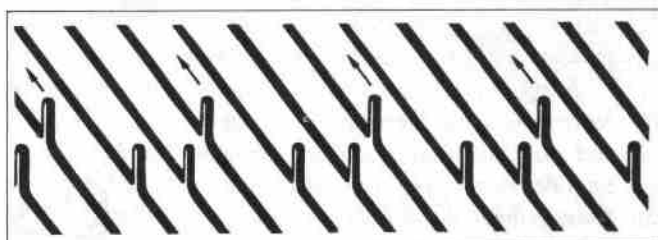

135

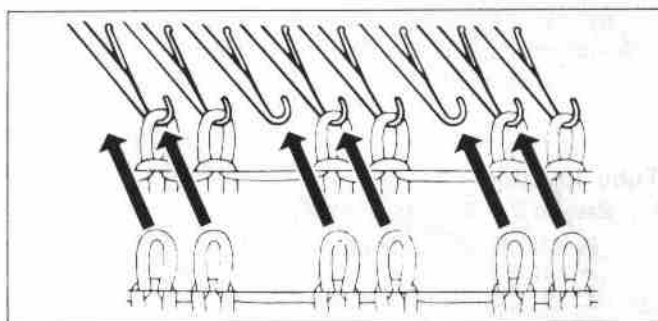

136

THE COMPLETED 2 X 1 RIB WILL LOOK LIKE THIS

(refers to 137)

So far you have learned to cast on with a double hem—now let's see some other methods of casting-on.



137

Finished edge cast-on(hand method)

Finished Edge Cast-on Hand Method

Place the carriage on the right and set the Tension Dial to 5.

Hang the cast on comb onto the pegs of the needle gate.

- (1) Bring forward to Position E, all the needles required.
- (2) Fasten the end of the yarn (threaded only through the yarn tension unit) onto the end needle on the left, using a slip knot.
- (3) Loop the yarn around each needle from left to right, counter clockwise. The loops must be pushed back on the stems of the needles. To control these loops as you wind, hold your thumb under the last one before making another. Do not make the loops too tight. (See Fig. 138—139).
- (4) Now thread the yarn into the feeder, and pull the strand (coming from the ball) down, to take up any slack.
- (5) Gently move the carriage to the left to knit the first row.
- (6) Lower the comb onto the stitches and see that the yarn goes above the comb pegs that are not opposite needles in action. Leave the comb suspended until about 10 rows have been completed.

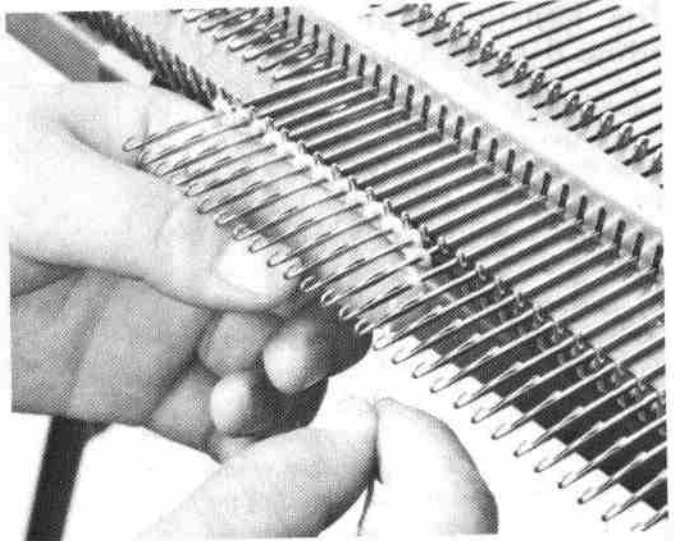

138

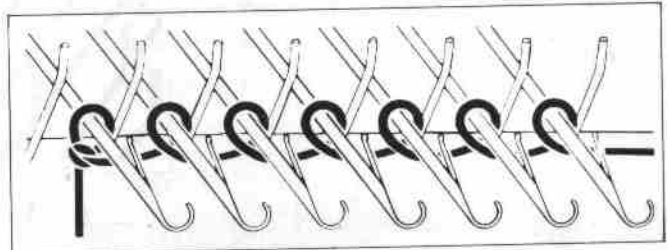

139

Tube knitting

- (1) Cast-on 3 or 4 needles.
- (2) To get fine finish, use a slightly tight tension.
- (3) Depress right PART button.
- (4) Pull down the fabric by left hand, and move the carriage by right hand.

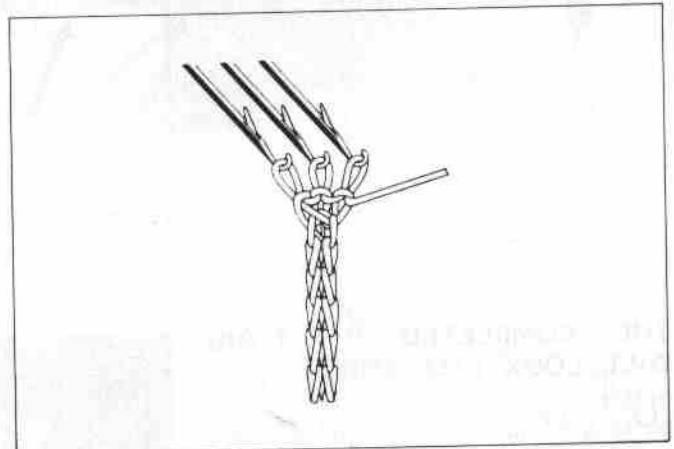

140

Knitting a picot hem

Picking up dropped stitches

Picot Hem

Set the machine as for the 'PLAIN HEM' and knit up to half the depth of the hem with the Tension Dial two numbers lower than required for that wool (i.e., if the hem is to be 50 rows then knit up to the end of the 25th row, starting from where the main wool joins the contrast colour).

Place the Lace Carriage (See section on Lacy knitting) onto the needle bed.

Push the needle selector buttons 1, 3, 5 and 7 and turn the set lever.

If an end needle is set then push it back to Position B by hand. Slide the Lace carriage across the needles in one movement. (This will transfer every second stitch to the adjacent needle—automatically).

Reset the Tension Dial to normal setting for that wool and take up any slack in the yarn from the carriage to the knitting.

Bring all the empty needles into a straight line together with the others in position B. knit the other half of the hem (i.e., 25 rows) and raise the first row of stitches as for the 'PLAIN HEM'.

Dropped Stitches A.

IF THE STITCH HAS DROPPED ONE ROW,

then with the single transfer tool pick up the stitch and the unknitted thread and put them both on the empty needle. Push the needle forward, until the stitch falls just behind the latch of the needle; catch the thread of the unknitted stitch into the hook of the needle, and push the needle back.

The stitch will slide over the closed hook of the needle and be re-knitted.

B. IF THE STITCH HAS DROPPED A NUMBER OF ROWS,

then insert the latch hook into the last stitch that has not dropped, from behind the fabric (i.e., the side that is not facing you).

- (1) Hold the latch hook at right angles to the knitting, and pull the knitting down slightly.
- (2) Push the tool towards you. The stitch will fall behind the latch. (See Fig. 141).
- (3) Now pull the tool back, at the same time catching the thread across in the hook. Make sure to position the hook in the centre of the horizontal thread, and to pull, the tool all the way back until the stitch is formed. (See Fig. 142).
- (4) In the same way knit the stitches all the way to the top stitch.
- (5) Place the transfer tool (or a crochet hook) into the hook of the latch tool, and transfer the last stitch onto the transfer tool. Now place the stitch onto the empty needle. (See Fig. 144).

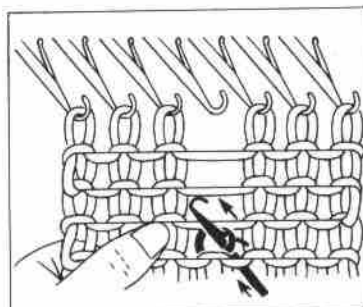

141

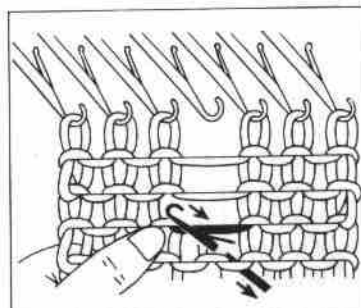

142

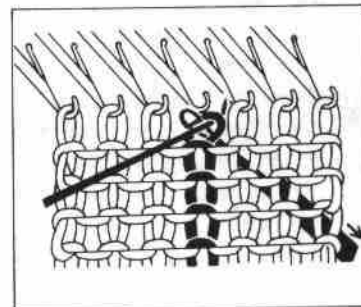

143

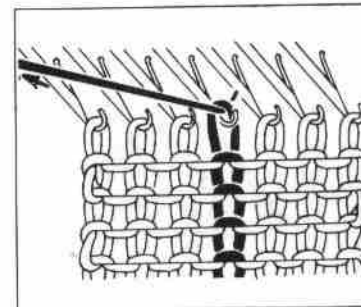

144

How to use the transfer tool

The transfer tools are used to move stitches onto different needles to effect the shaping of the garment, and also to form lacy patterns. Before transferring the stitches you should open the latches of the needles to be used.

- (1) Hold the one eyed transfer tool parallel with the needles. Place the eye into the hook of the needle. (See Fig. 145).

Place the eye into the hook of the needle. (See Fig. 145).

- (2) With the transfer tool, bring the needle forward. The stitch in the hook of the needle will slide behind the latch and onto the stem of the needle. (See Fig. 146).

- (3) Without releasing the transfer tool, push the needle all the way back until the stitch is transferred onto the transfer tool (See Fig. 147).

- (4) Raise the transfer tool with the stitch on it and transfer it to the adjacent needle, right or left as desired. (See Fig 148).

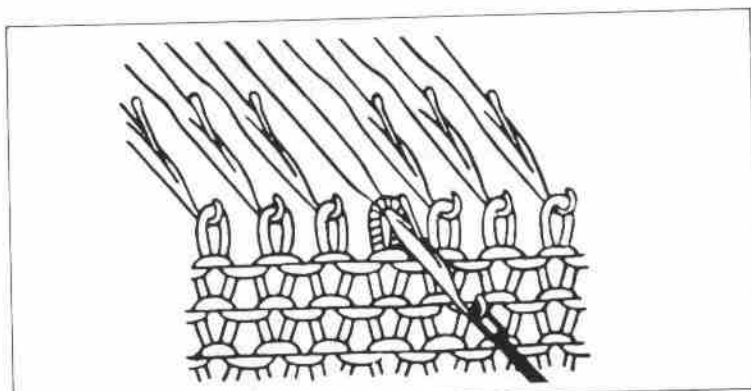

145

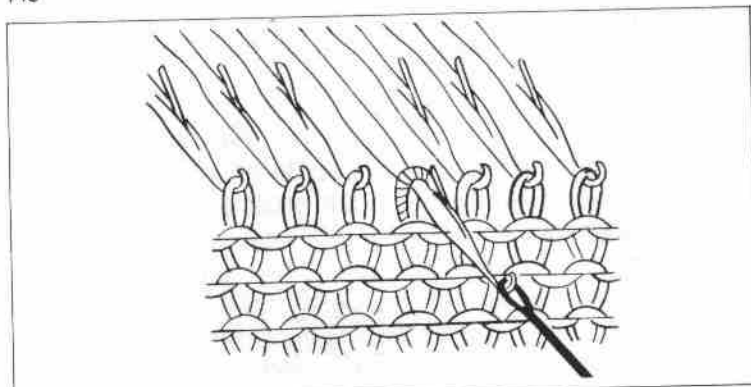

146

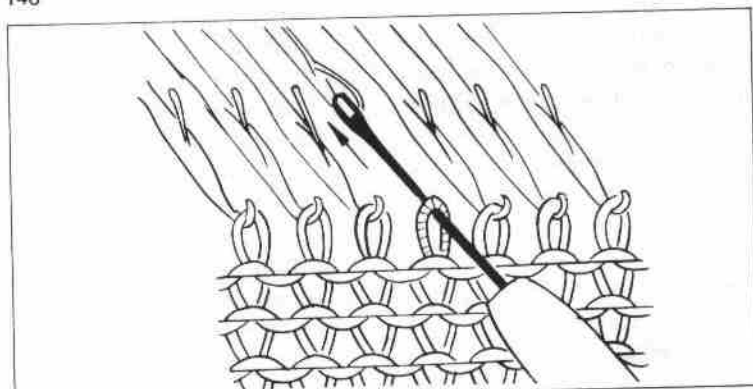

147

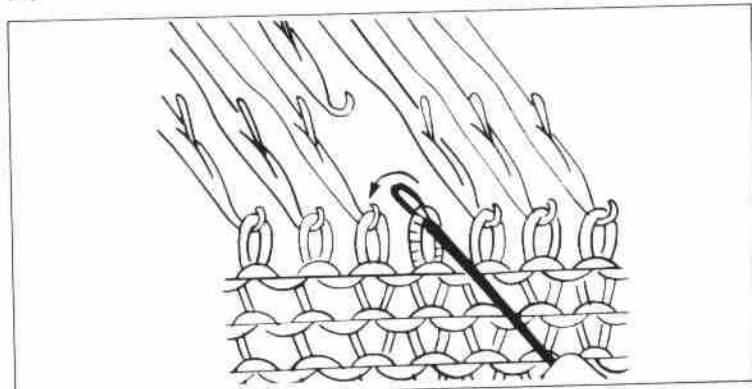

148

Increasing stitches

ONE STITCH AT EITHER EDGE

A. SIMPLE METHOD.

Simply bring into working position B one needle from position A, on the side nearest the carriage.

The empty needle will pick up the yarn on the next row.

B. FULLY FASHIONED METHOD.

- (1) Using the two needle transfer tool, move the stitches out by one needle so that the third needle from the end becomes empty. (See Fig. 149).
- (2) To fill in the empty needle pick up the purl side of either adjacent stitch on the lower row. (See Fig. 150).

SEVERAL STITCHES AT EITHER EDGE

- (1) Push the needles to be increased, to Position E on the same side as the carriage.
- (2) Loosely wind the yarn around the stems of each needle, going around the needles from below. (See Fig. 151).
- (3) Set the H.C.Ls. to Position I.
- (4) Knit across one row. To ensure perfect knitting on the increased stitches, raise these needles to Position E before knitting across for the next 2 or 3 rows.

INCREASING ONE STITCH IN THE CENTER ROW

- (1) Determine the position where you want to increase one stitch.
- (2) Use the 3 needle transfer tool, starting from either end, transfer all the stitches outward in either direction until the required needle is free. (See Fig. 152).
- (3) Pick up the adjacent lower half stitch onto the empty needle. (See Fig. 153).

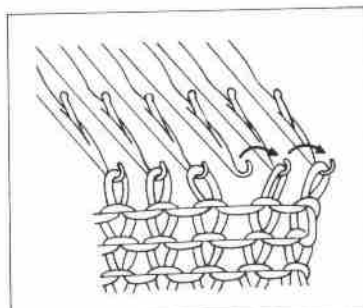

149

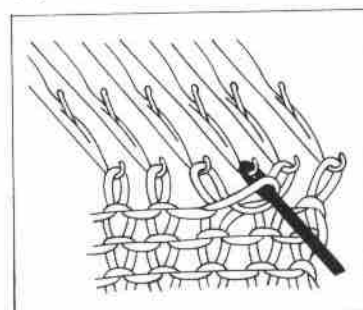

150

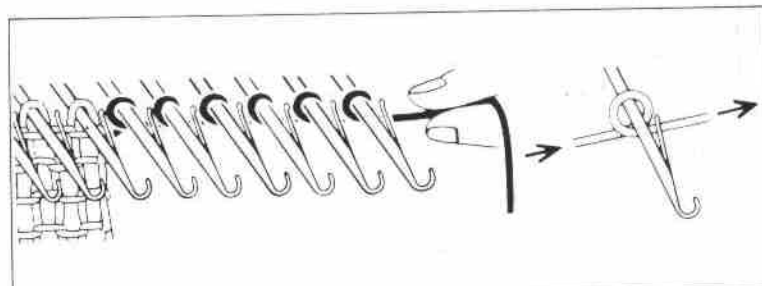

151

INCREASING SEVERAL STITCHES IN THE ROW

The afore mentioned method can be used working from the centre outwards, or you can transfer the knitting from the knitter to a knitting needle and then return the stitches. Before the knitting is transferred back from the knitting needles to the knitter, determine the number of stitches to be increased and space the replaced stitches so that there will be an equal number of stitches transferred between each extra needle (leaving empty needles where extra stitches are required). Raise the neighbouring lower half stitches to the empty needles. (See Fig. 153).

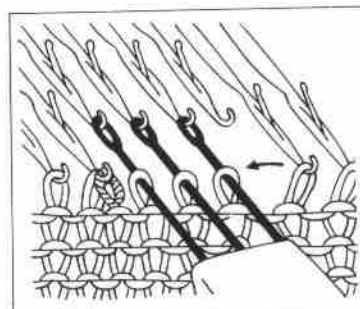

152

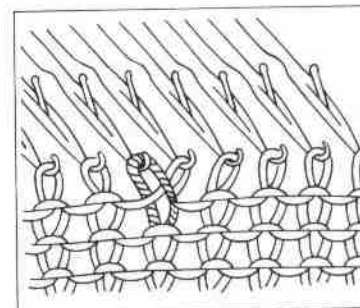

153

Transferring to hand knitting needles

- (1) Slide a hand knitting needle into the first stitch from behind the knitting. With your left hand hold the knitting close to the knitter. With your finger, bring the needle forward so that the stitch in the hook of the needle slide onto the stem of the needle, behind the latch.
- (2) Push the needle all the way back so that the stitch slips all over the closed hook of the needle onto the knitting needle.
- (3) Slide the knitting needle into the next stitch and repeat until all the stitches are off the needles on the needle bed.

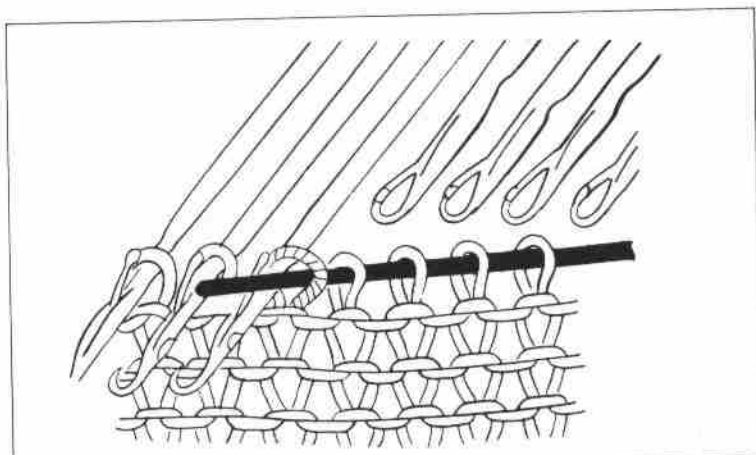

154

TRANSFERRING OFF THE HAND KNITTING NEEDLE ONTO THE KNITTER

A. USING THE TRANSFER TOOL.

- (1) Open the needle latches.
- (2) Hold the fabric in your left hand with the desired side facing you, the hand knitting needle being in line with the needles.
- (3) Pass the transfer tool through the stitch on the knitting needle from the front. (See Fig. 155).
- (4) Transfer the stitch from the transfer tool onto the hook of machine needles. Push the needle with the transferred stitches back as far as they will go.

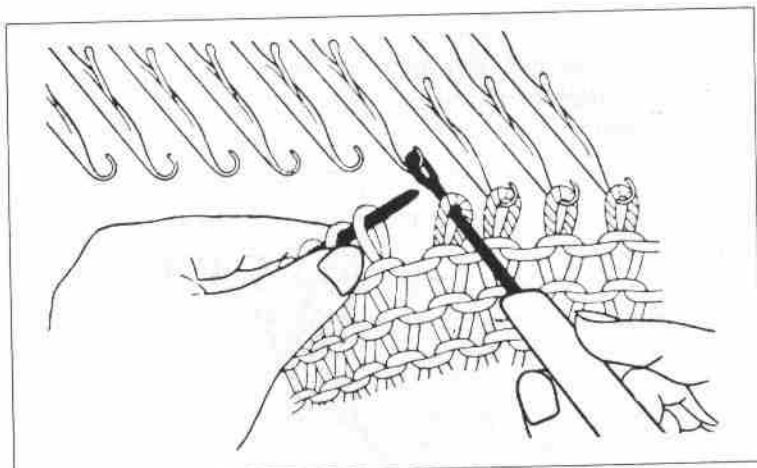

155

B. ALTERNATE METHOD

- (1) Bring the needles forward to Position 'DI', and open the latches.
- (2) Begin from the left side.
- (3) Transfer the stitches from the hand knitting needle onto the open hooks of the machine needles. (See Fig. 156).

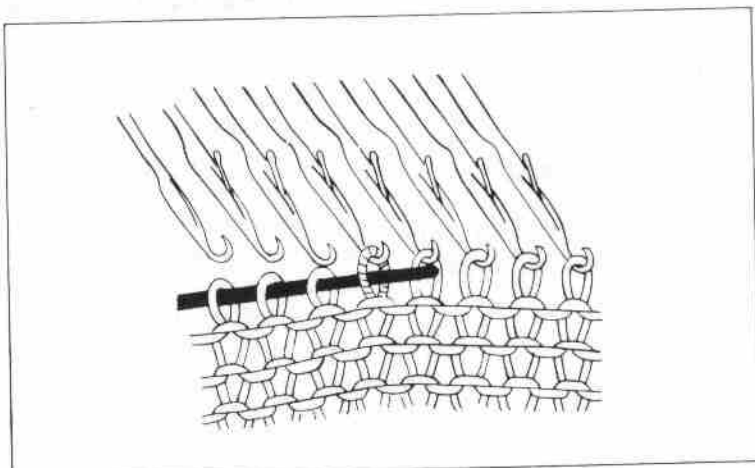

156

Decreasing stitches

ONE STITCH AT EITHER DEGE

A. SIMPLE METHOD.

Using the single transfer tool, transfer the end stitch onto the second needle (See Fig. 157) and push empty needle back to Position 'A'.

B. FULLY FASHIONED DECREASING.

With the single transfer tool, transfer 2nd stitch onto 1st stitch, then bring both back onto 2nd needle and knit. For decreasing at NECK, ARM-HOLES AND SLEEVES, it is advisable to use the 2 prong transfer tool and move 2 stitches in (towards knitting) 1 stitch. (K1, K2 tog.).

DECREASING ONE STITCH IN THE CENTRE OF ROW

- (1) Use the single transfer tool and transfer a center stitch to adjacent needle. (See Fig. 158).
- (2) Using the 3 needle transfer tool, shift all stitches in until all needles 'in action' have stitches on them, and place the outer empty needles out of action. (See Fig. 159).

DECREASING SEVERAL STITCHES IN A ROW

- (1) Transfer the knitting to a hand knitting needle: (See Fig. 154).
- (2) Before returning the knitting from the knitting needle back to the knitter, calculate the proportional reduction in the number of stitches.
For example, to decrease one stitch in every three, hang the 2nd and 3rd stitches both onto one needle. (See Fig 160).
- (3) The number of needles with double stitches represents the number of stitches decreased.

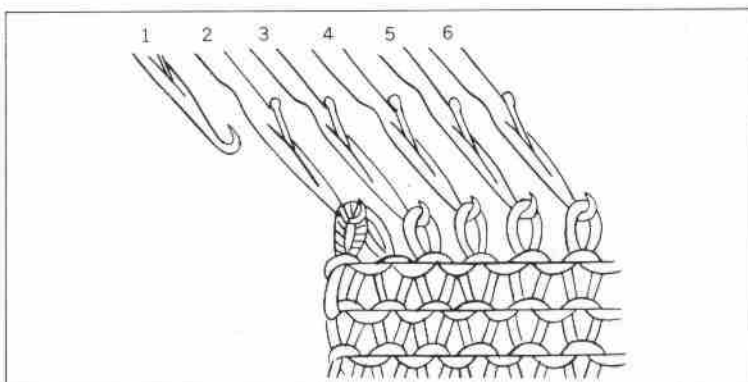

157

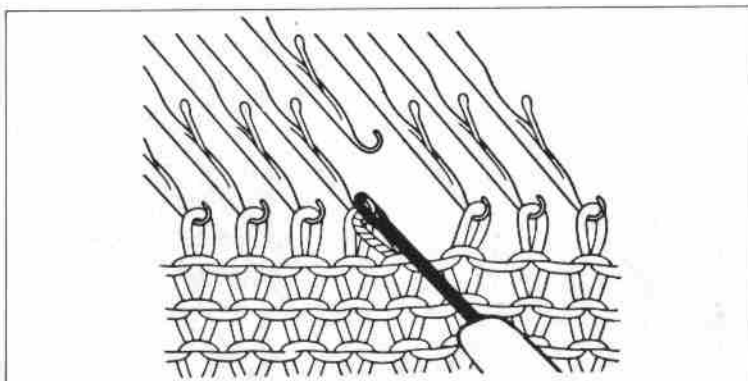

158

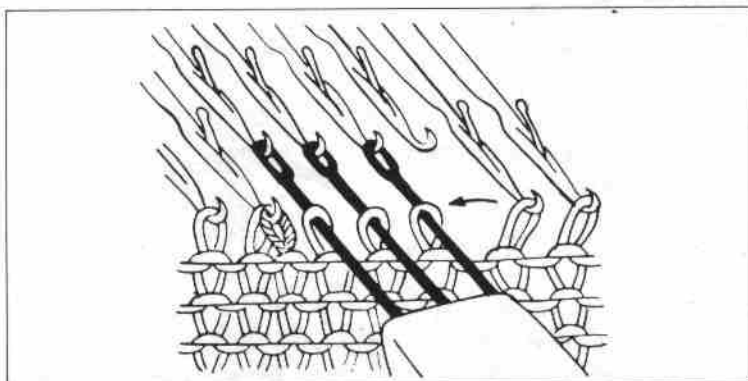

159

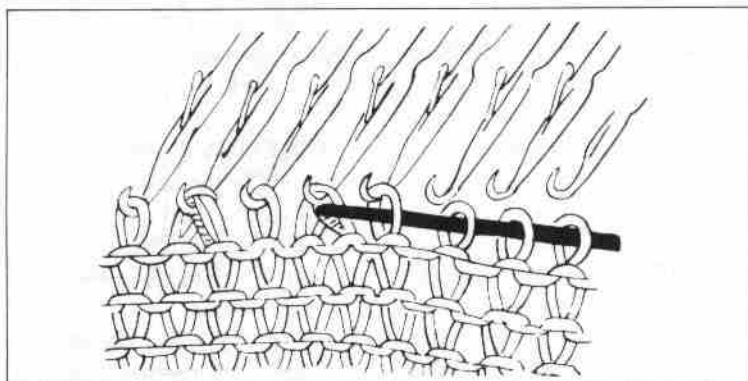

160

Casting-off

METHOD A

- (1) On the same side as the carriage, transfer the end stitch to the 2nd needle. (See Fig. 161).
- (2) Bring forward the needle with the two stitches so that the stitches fall behind the needle latch. (See Fig. 162).
- (3) Place the yarn in the needle hook in front of the latch and push the needle back manually to form a single stitch. (See Fig. 163).
- (4) Repeat this process for each stitch. Take care not to make the stitches too tight.

After practicing this, you may find it easier to transfer the stitch you have formed by hand, without using the transfer tool.

METHOD B

This method can be used for binding off any number of stitches at neck, armhole, shoulder or pocket edges.

- (1) Knit the last row on a much looser tension than the rest of the garment.
- (2) Start on the side opposite the carriage.
- (3) Hold the latch tool upright, so latch remains open.
- (4) Insert the latch hook into the first 2 stitches and remove them from the needles. Let the first stitch slide past the latch.
- (5) Pull the second stitch through the first—this leaves one loop in the hook of your latch tool. Continue to bind off one stitch at a time, and seal the last stitch with a slip knot. (See Figs. 165 and 166). No mention is made in these instructions of de-

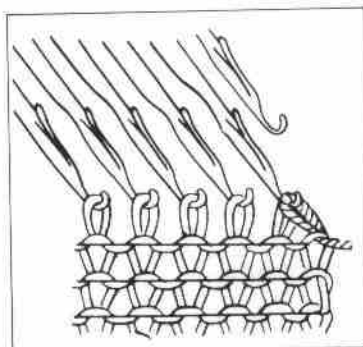

161

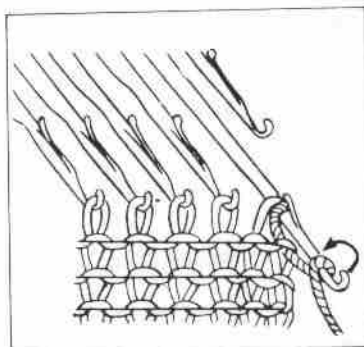

162

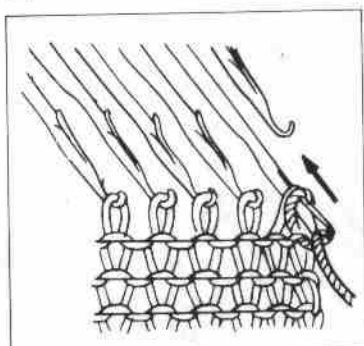

163

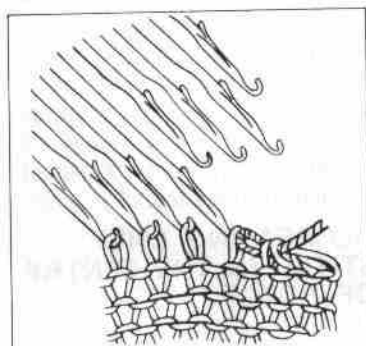

164

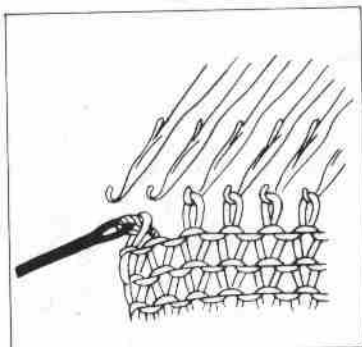

165

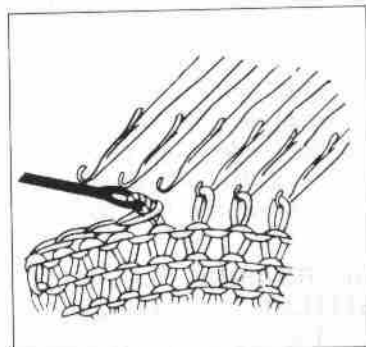

166

creasing at the centre of the neck or of shaping at the armholes. Whilst following the steps below, the decreasing and shaping must be carried out according to the instructions in the knitting pattern, or according to the measurements of the garment. Remember to put all empty needles back to Position 'A' after transferring and before continuing to knit.

TO REMOVE THE KNITTING FROM THE KNITTER

Unbound (unfinished) method.

- (1) Take the yarn out of the yarn feeder on the carriage, and rethread with any contrast colour yarn (waste yarn).
- (2) Knit 5 rows using the waste yarn, then remove the yarn from the yarn feeder.
- (3) Press the work against the needle bed and slide the carriage twice across the needles in action. The work will be released.

Button-holes small Button-holes medium

Small

- (1) Open the latches of two needles where the button-hole is to be.
- (2) Using the one eyed transfer tool, move the stitches on the right over to the left.
- (3) Bring back the butt of the empty needle to Position B, and continue to knit.

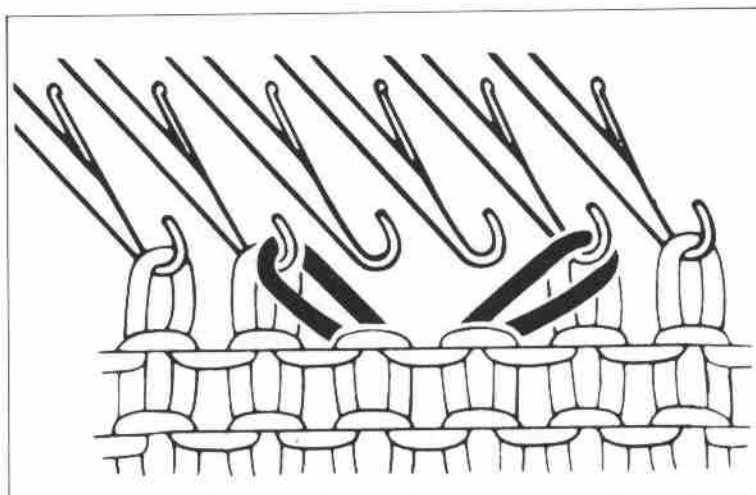

167

Medium

- (1) OPEN THE LATCHES OF A GROUP OF FOUR NEEDLES.
- (2) Transfer the inner two stitches to the adjacent outer needles (See Fig. 167).
- (3) Return the two empty needles to Position B and knit one row (See Fig. 168).
- (4) The loops must be twisted by hand to form stitches (See Fig. 169).

To ensure that these needles knit on the next few rows, bring them both forward to Position E (for next 2 rows), making sure that the loops fall behind the latches.

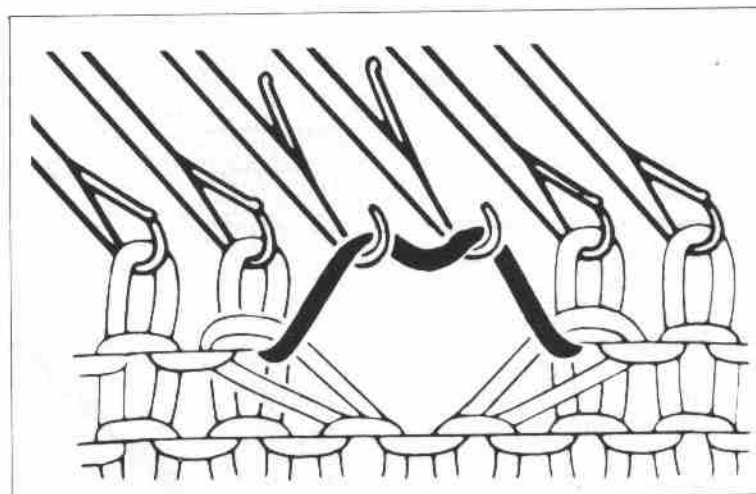

168

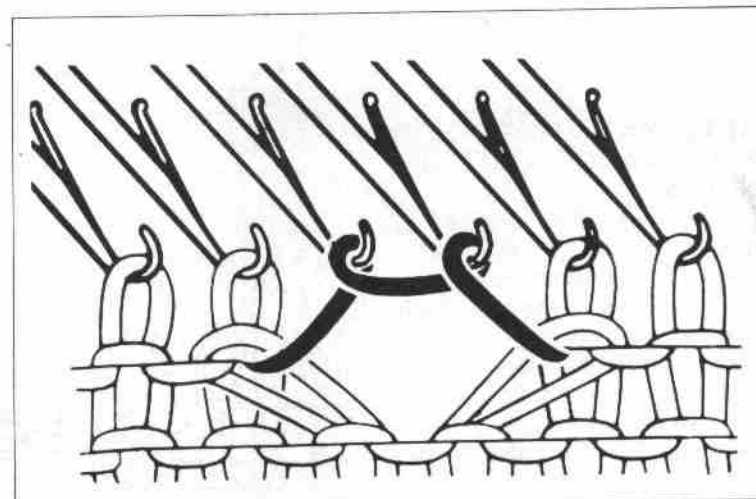

169

Button-holes Large

- (1) Determine the position of the buttonhole. Purl the stitch adjacent to where you want the buttonhole to start. (Fig. 170).
- (2) Catch the purl half stitch and bring it forward onto the latch hook (See Fig. 171). With this as your first stitch, crochet through the next adjacent stitches of the buttonhole—thus casting off (See Fig. 172).
- (3) Transfer the stitch off the latch hook, onto the next adjacent needle (See Fig. 172).
- (4) Knit one row (H.C.L.s. on l). The wool will loop over the empty needles (See Fig. 173).
- (5) Starting from the end where the bottom part was sealed off—wind the wool around each needle individually. If there is any left over (this will depend on the tension you are using) then wind an extra loop around each adjacent needle (See Fig. 173). Do not wind too tightly.
- (6) Raise the needles with the wound loops and a few adjacent needles on either side to Position E. Make sure the loops fall behind the latches. Continue to raise these needle (if it does not interfere with the pattern) for the next two or three rows of knitting.

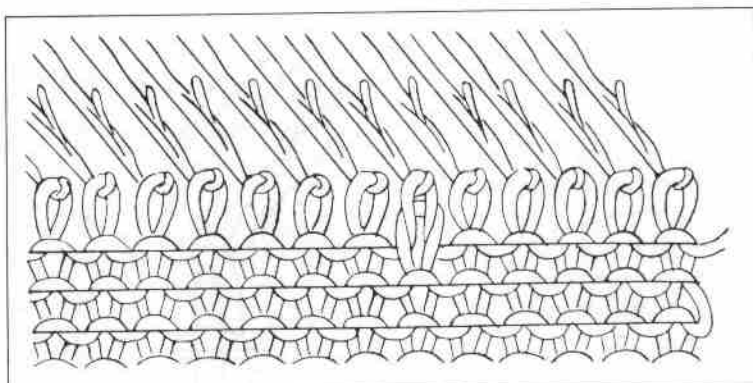

170

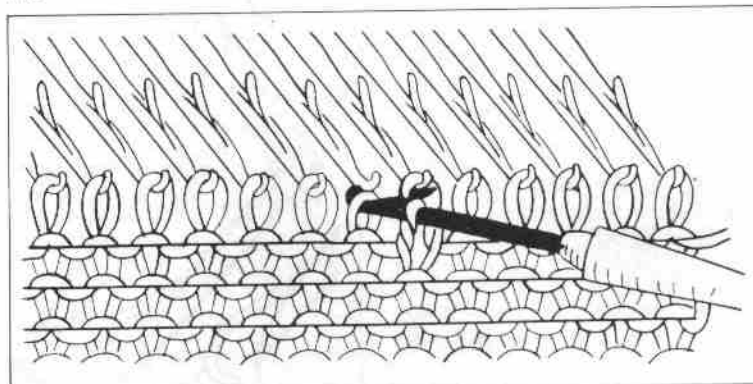

171

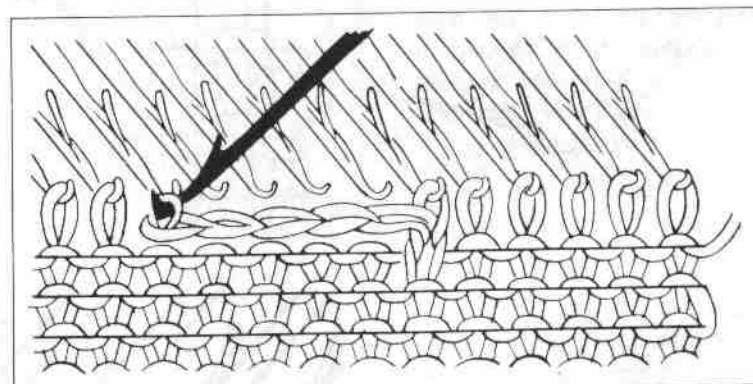

172

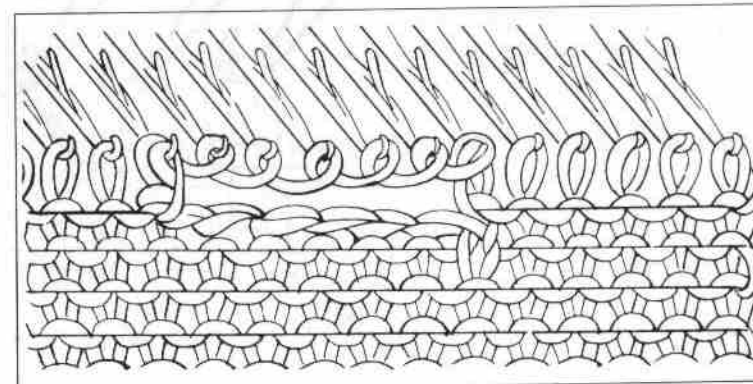

173

ALTERNATIVE METHOD FOR LARGE BUTTON-HOLES

Bring forward the number of needles needed for the button hole to "D1" position making sure the stitches pass behind the latch. Place a length of contrast colour yarn in the hooks of these needles and knit the stitches by pulling the needles back to B position. Continue knitting until the garment is completed. The button-hole can be finished by stitching, and the contrast wool taken out.

Making a vertical buttonhole How to knit a pocket

Making a Vertical Button Hole

Knit up to the row where the buttonhole starts. If the carriage is on the right side of the needle bed, knit the right side of the buttonhole first.

- (1) Set the H.C.Ls to Position III.
- (2) Determine where the buttonhole is to be and bring forward to Position 'E' all the needles on the left of the buttonhole.
- (3) Knit 6 rows. (If a larger buttonhole is desired, knit as many rows as is necessary.)
- (4) Break the yarn; take the carriage off the needle bed and replace it on the other side.
- (5) Return the needles that were in position 'E' to Position 'B' and bring forward the needles on the right to Position 'E'.
- (6) Knit the left side of the buttonhole, the same number of rows as for the right side. After you have completed the same number of rows, set the H.C.Ls. to Position I and continue to knit.

Instructions are given for the carriage on the right side of the bed.

How to knit a Pocket

- (1) Determine the position of the pocket, and bring forward to Position 'E' all the needles on the left of the pocket.
- (2) Set the H.C.Ls. to Position II.
- (3) Knit one row and bring forward to Position 'E' all the needles on the right of the pocket.
- (4) Knit one row again.
- (5) The carriage is now on the right and you can knit the amount of rows required for the pocket. Move the carriage across slowly with one hand and put the other hand behind the fabric and pull the knitting down slightly. Finish the completed pocket with the carriage on the right.
- (6) Push the needles on the left back to Position 'B' taking care not to let the stitches fall over the latches.
- (7) Knit one row, and set the H.C.Ls. to Position I.
- (8) Continue knitting the garment.
The pocket can now be pulled through to the side of the fabric facing you.
To complete the pocket sew up (or weave) the stitches at the sides.

174

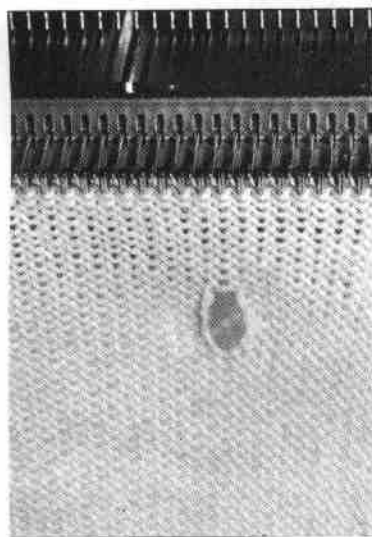

175

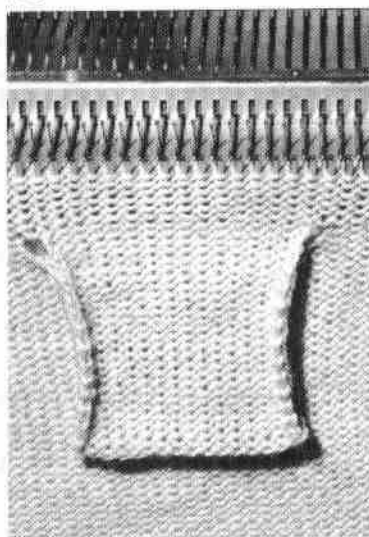

Shaping a 'Vee' neck

Knit the fabric to the row where the 'V' neck commences. The instructions are written to start with the carriage on the right side of the bed. If the carriage is on the left then read LEFT for RIGHT and vice versa.

- (1) Place the H.C.Ls. on II.
- (2) Bring the forward to position 'E' all the needles on the left side of the centre '0'. These needles will not knit until the right side is completed. (If you wish you may take them off onto a knitting needle and replace them later).
- (3) Transfer the first stitch on the right of '0' to the adjacent needle on the right (in Pos. 'B'). Return the empty needle to Pos. 'A'.

N.B. FOR FULLY FASHIONED—transfer both first and second stitches onto the second and third needles, and continue transferring two at a time.

- (4) Knit two rows.
- (5) Continue decreasing one stitch every two rows until you have the required number of stitches left for the shoulder. Bind off these stitches and break the wool.
- (6) Return all needles at left to Pos. 'B' by putting three at a time onto a transfer tool, and slipping the stitches inside the needle hooks (i.e., not behind the latches). Knit this side identical to the other.

KNITTING THE BAND TO THE 'V' NECK

Bring forward to Position 'B' the number of needles required for HALF the neck and back of garment.

Open the latches of all these needles.

Set the carriage and machine dials as for Plain knitting. With the wrong side of work facing you, and using the one eyed transfer tool, pick up the 1st stitch nearest to the 'V' onto the first needle nearest to the carriage.

Now continue to raise all the stitches from the half 'V' onto the empty needles. (You may prefer to have the band tighter and therefore raise all the stitches onto $\frac{1}{2}$ the corresponding number of needles. To do this, miss out every 4th stitch and raise every 5th stitch onto every 4th needle).

IF YOU WISH TO DO THE NECKBAND IN ONLY TWO PIECES THEN RAISE HALF THE STITCHES FROM THE BACK OF THE GARMENT ONTO THE NEEDLES AFTER RAISING HALF THE NECK STITCHES.

With the same yarn knit one row across (N.B. All needle butts should be in Position 'B').

YOU CAN NOW KNIT THE BAND

The bottom end of the band should be mitred (for the V shape), by decreasing at the 'V' end until the hem is halfway through.

Now increase in reverse order so that when the band is completed you have the same number of stitches on—as when started.

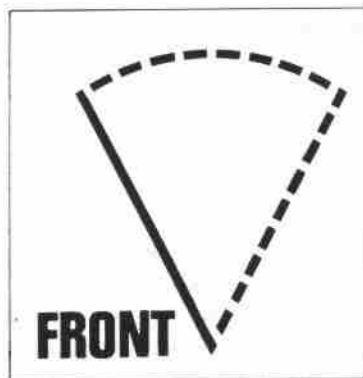

176

REPEAT THE SAME PROCESS FOR THE OTHER SIDE OF THE NECK STARTING AT THE 'V'.

FAIR ISLE: NECK SHAPING:

Note Row counter number and pattern row on operation table Carriage on the right. Knit off manually with waste yarn and push into A position, $\frac{1}{2}$ or required number of stitches furthest from carriage. Knit and finish one side. Bring stitches on waste back into B position. Press in both Part Buttons. Set row counter to beginning of shaping row and continue as before reversing all shapings.

Shaping a round neck

Shaping a square neck

Round neck

Instructions are given for the carriage on the right side of the needle bed.

- (1) Place the H.C.Ls. on Position II.
- (2) Bring forward to Position 'E' all the needles on the left side of the centre '0'.
- (3) The decreasing of the stitches is done by bringing forward to Position 'E', the needles you wish to decrease. Start with the needles in Position 'B' on the right of '0' and knit two rows each time you bring needles forward.
- (4) Decrease in this manner until you have the required number of stitches left in Pos. 'B' for the shoulder.
- (5) Bind off these stitches and break the yarn.
- (6) Return the needles on the left back to Position 'B' and repeat as above, from 3 to 5. Remember to leave the same amount of needles for the shoulder. Bind off these stitches.
- (7) Place the end stitches of the round neck onto the knitter.
- (8) Place the carriage on the left and thread the yarn feeder. H.C.Ls. on Position I.

KNITTING THE NECK BAND

- (9) Knit the first half of the hem (approx. 5 rows) on a normal tension for that yarn.
 - (10) Knit one row on a tension 3 numbers higher. This will ensure that the fold will be flat.
 - (11) Knit the other half of the band on the same tension as used in No. 9. (N.B. It must be the same amount of rows as the first half).
 - (12) Using the transfer tool, raise the stitches from the end of the round neck onto the needles. Take care to raise each stitch onto the corresponding needle to obtain a perfect round effect.
 - (13) When all the stitches have been raised, bind off the double stitches in the normal way.
- N.B. Seal the stitches by hand very loosely, to allow for the neck to fall back into place after removing the knitting from the machine.

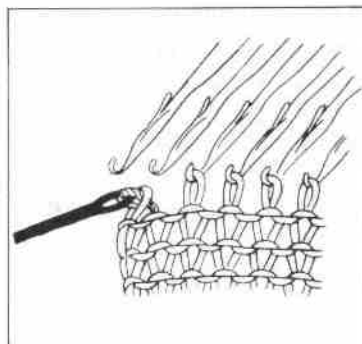

177

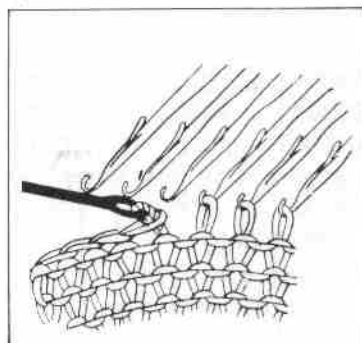

178

Square neck

Cast off the needles in the centre, for the width of the neck, using the same wool as that for the garment.

Return needles to Position 'A'.

On the opposite side to the carriage bring forward all the needles to Position 'E'.

Set the H.C.Ls. to II.

Knit the required number of rows to complete the side nearest the carriage.

Cast off and return the needles to Position 'A'.

Set H.C.Ls. to I and knit other half identical to first.

Short row designing

SHORT ROW DESIGNING

This method of shaping has endless possibilities and is used most frequently for:

Turning the heel of socks; pockets; horizontal darts; circular piece-yokes, skirts and zig-zag designs.

Set the H.C.Ls. to Position III, then put one or more needles in Position 'E', so that these needles stop knitting and hold the stitches for further use.

TWO COLOURS DIAGONAL KNIT (USING SHORT ROW METHOD)

- (1) Start with the carriage at the right and the H.C.Ls. on Position III.
- (2) Raise two needles on the left to Position 'E'.
- (3) Knit one row to left and pass the yarn under the stem of the needle in Position 'E' on the right. Knit one row to the right.
- (4) Continue raising two needles and knitting 2 rows as above, until all needles are in Position 'E'.
- (5) Change the yarn; remove carriage from the right side and place on the left side of knitter. Starting at the left push into Position 'C' two needles at a time, and knit one row to the left and one to the right.
(Reversing the previous process until all needles are back in knitting position).

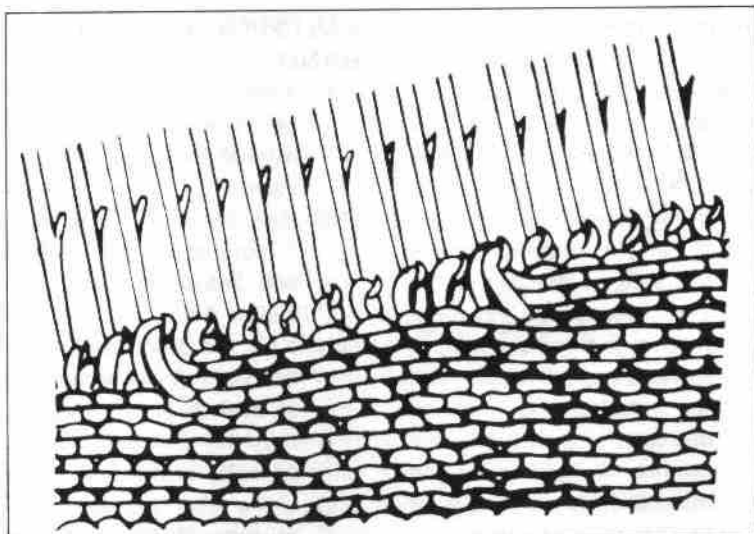

179

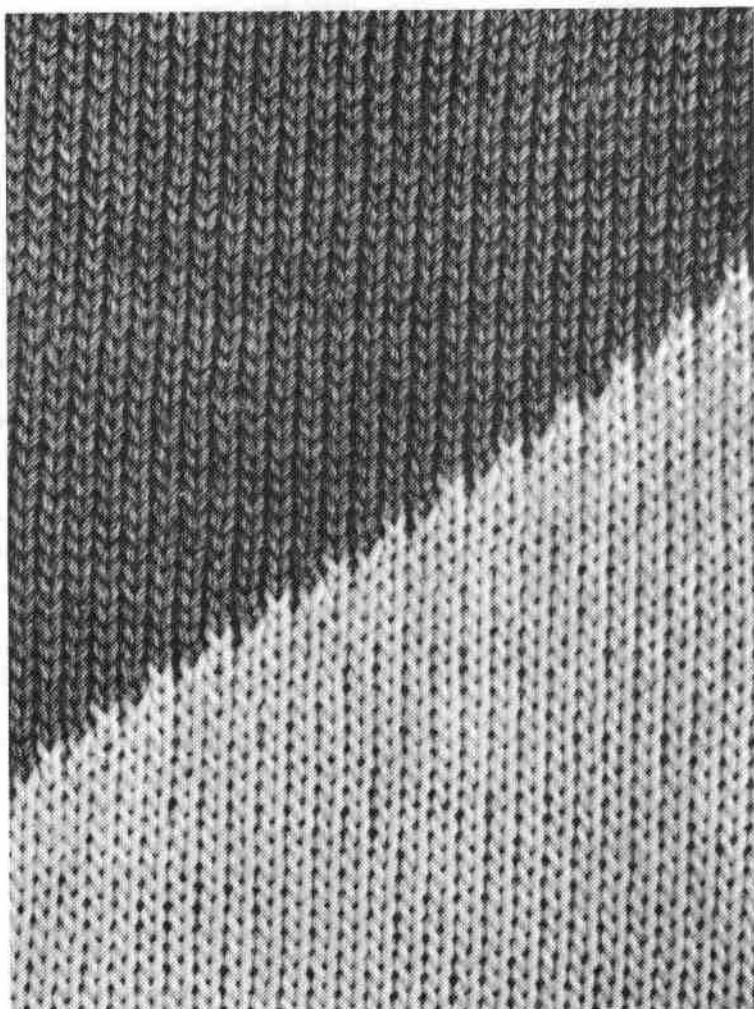

180

How to correct the lace knitting

IF THE 'L' CARRIAGE SHOULD JAM

Push the Release button of the L carriage, and remove the L carriage from its jammed position. If the 'L' carriage is caught with the needles, take care in removing it.

After removing the 'L' carriage, you can knit according to the following steps.

- (1) If you see needles caught with each other, separate them by lifting their tips.
- (2) If stitches are caught on two needles as shown by (a) in above figure, pull selected needles (b) toward you and push them back together with needles (c) to position 'B' in order to transfer the stitches.
- (3) For other part, transfer the stitch of selected needles (b) with the transfer tool to the adjacent needles. (For use of the transfer tool, see page 44).

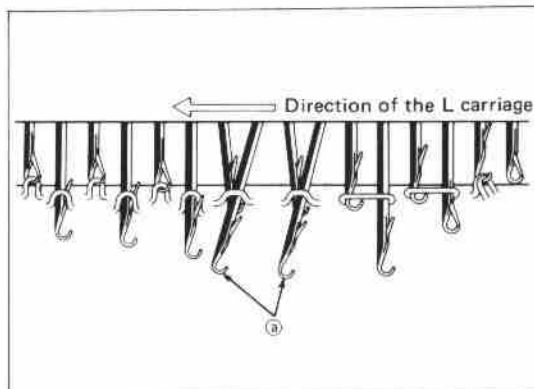

181

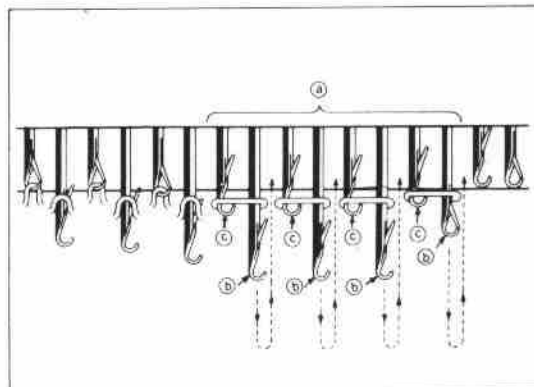

182

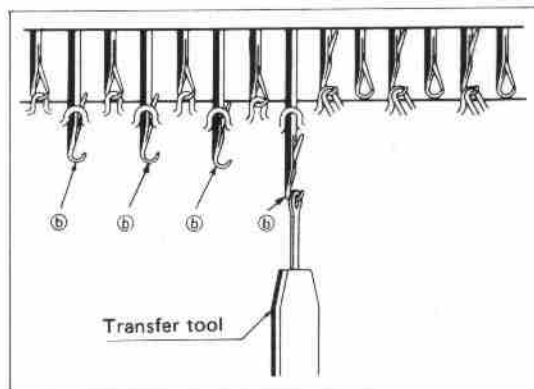

183

REPLACING A BENT OR BROKEN NEEDLE

- (1) Push either side of the felt bar with the end of the latch tool until it comes out.
- (2) Withdraw it by hand from the knitter until the needle you wish to change is free.
- (3) Pull the needle forward as far as it will go. Push down the hook of the needle until shank end of the needle rises clear of the needle bed.
- (4) Grasp the shank end and draw it out backwards.
- (5) Replace it with a new needle by holding it with latch opened. Push the felt bar back into place.

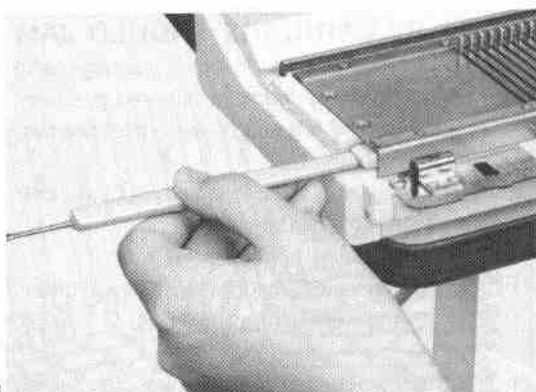

184

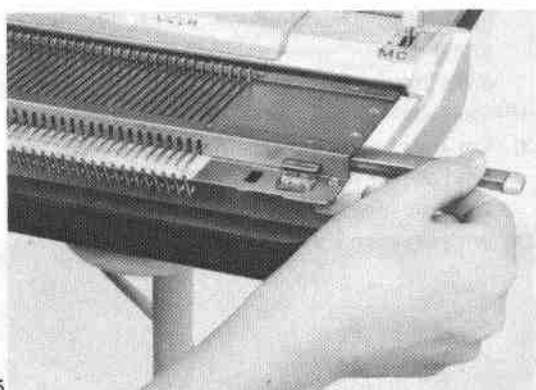

185

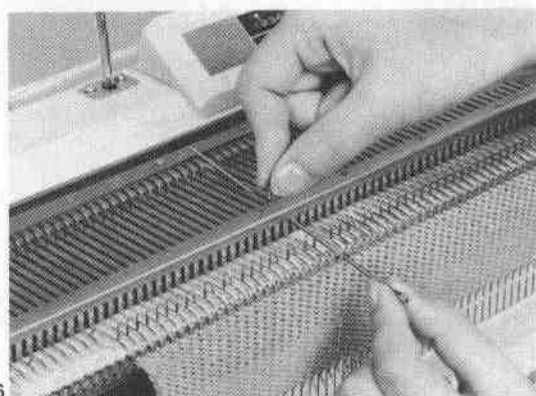

186

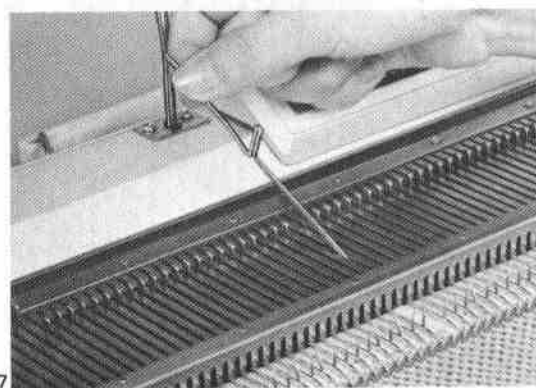

187

Maintenance

ALL THE INSTRUCTION ON THE MACHINE IS NOW FINISHED AND YOU SHOULD GO BACK AND PRACTICE THE THINGS YOU ARE NOT SURE OF.

CLEANING AND OILING.

Before and during use.

For best results your knitter must be kept clean and the carriage regularly oiled.



CARE OF MACHINE

1. Remove carriage from needle bed.
2. Brush off all fluff that has gathered on the working parts underneath the carriage.
3. Oil runners on carriage and sides of all cams. Main cams under carriage should be oiled whenever a drag is felt when using carriage.
4. Clean your knitter of fluff and excess oil each time you have finished knitting.
Oil before using.
5. Keep machine covered at all times when not in use to prevent dust.
6. If carriage jams, never force it along, as it will not only bend or even break needles—it can damage the needle grooves.
7. Replace any bent needle or needles with latches that do not sit flat back against the needle shaft.

188

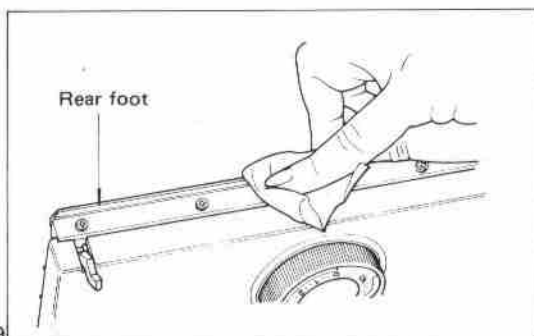

189

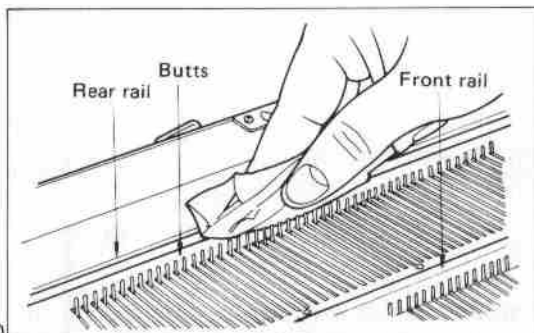

190

YOU SHOULD CLEAN AND OIL YOUR MACHINE BEFORE USING IT EVERY TIME.

Always leave a light film of oil on all parts between the rails under the carriage.

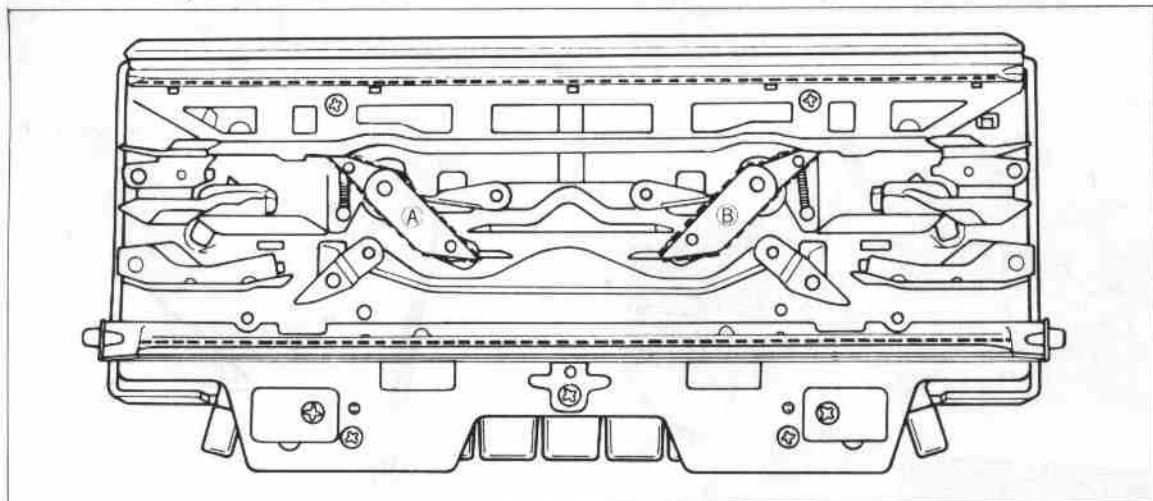

191

Folding up knitter

- (1) Replace the cast on comb in the case.

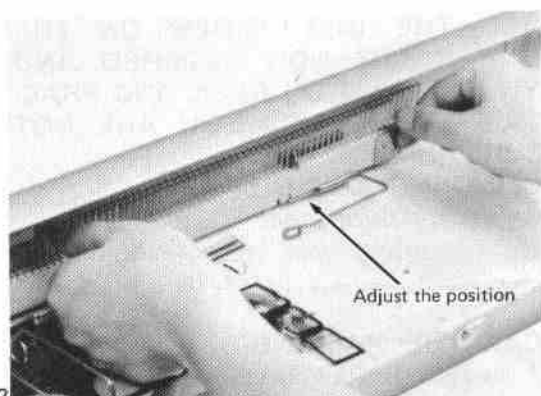

192

- (2) Remove the extension rails (lift up and pull it.)

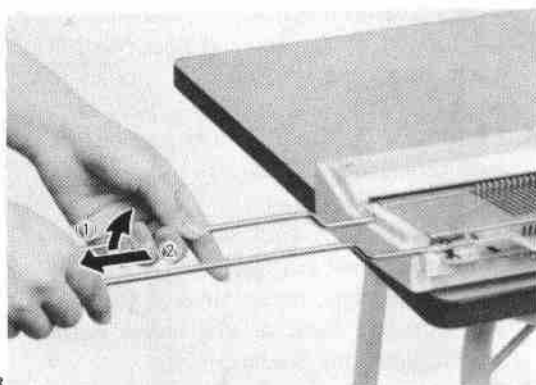

193

- (3) Replace the extension rails in the upper case as shown in figure.

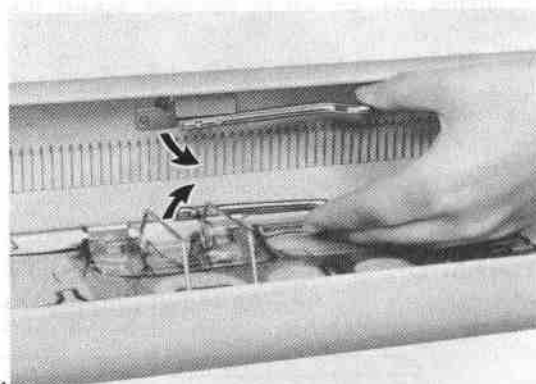

194

- (4) Fold up the automatic yarn tension unit. Remove the automatic yarn tension unit. see Fig. 196 to 199.

195

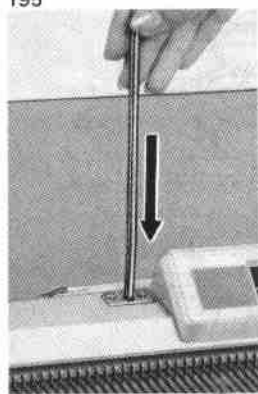

196



197



198

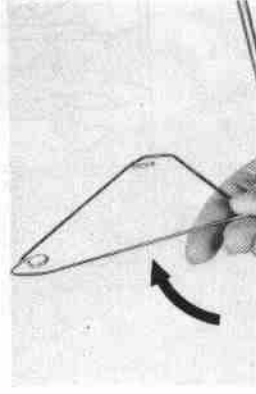

- (5) Replace the automatic yarn tension unit as shown in figure. (Fit the head A of automatic yarn tension unit under the clasp B of the case.)

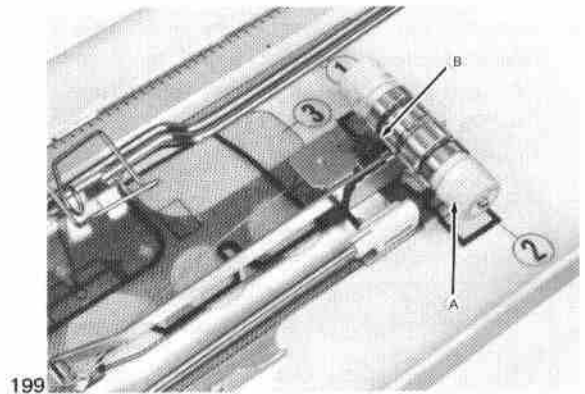

- (6) Place the yarn tension rod and the take-up springs and put them inside of hook C.

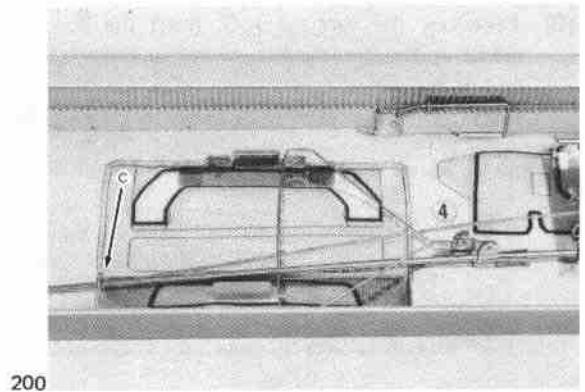

- (7) Fold up the handle of the L carriage and replace the L carriage as shown in figure. Make sure that the L carriage is locked into the holder plate of the case.

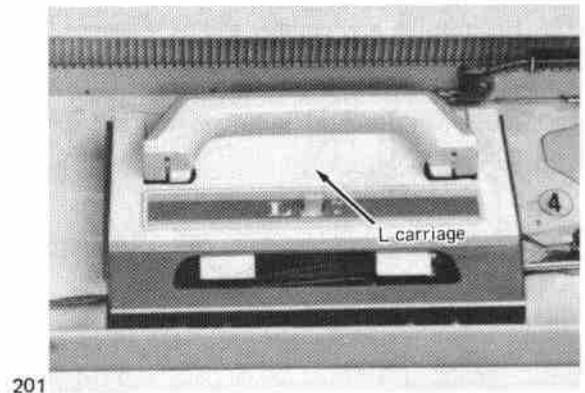

- (8) Place the sinker plate as shown in figure and close the spring.

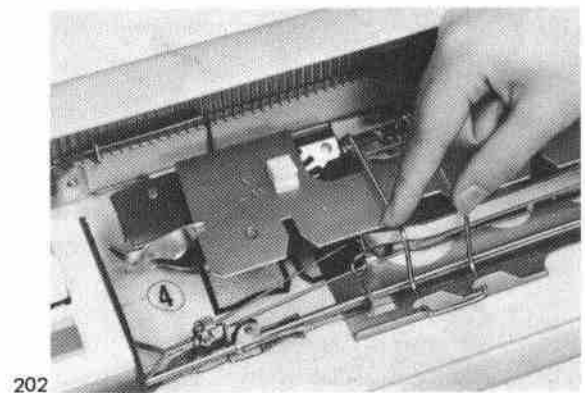

- (9) Remove the set lever, push down the release button, set the reverse lever to "A" and push back all needles to position "A".

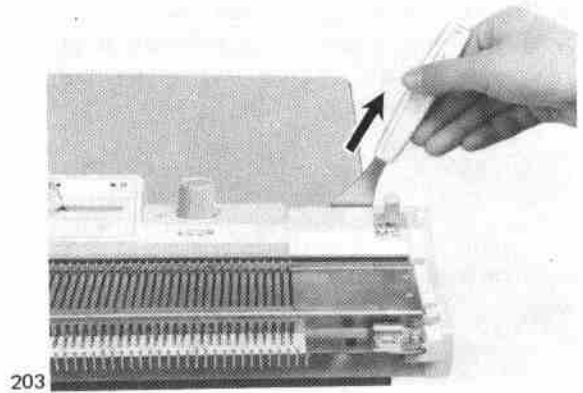

203

- (10) Take out the carriage lock from the accessories box and lock carriage on the left end of the needle bed. Fold up the handle of the carriage.

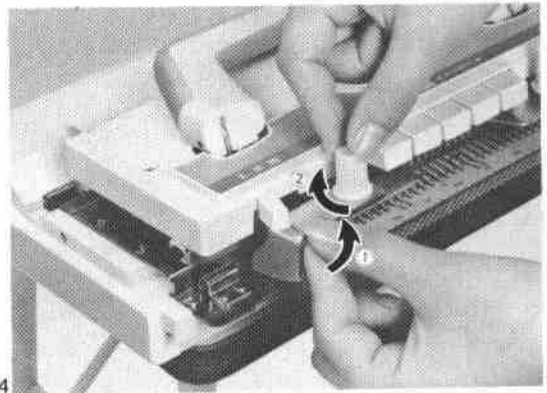

204

- (11) Remove the row counter and table clamps, and replace them into the accessories box together with the set lever, claw weights and small tools as shown in the photograph.

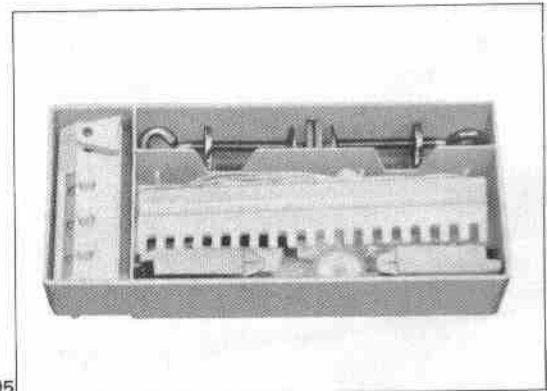

205

- (12) Place the accessories box as shown in the illustration.

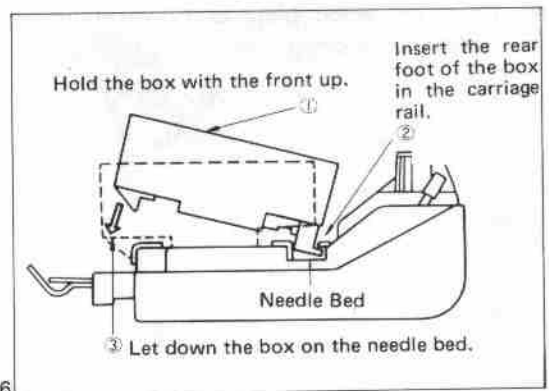

206

- (13) Place the box on the right side of the needle bed. The left end of the box must be in line with the right 65th needle.

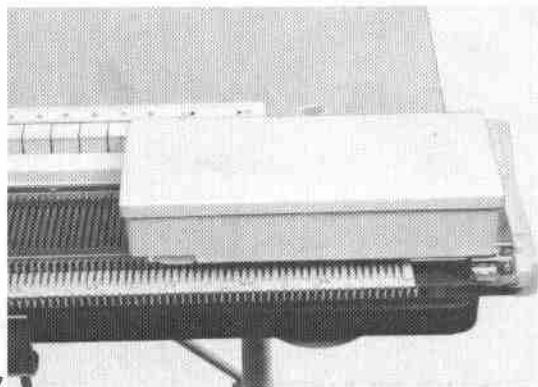

207

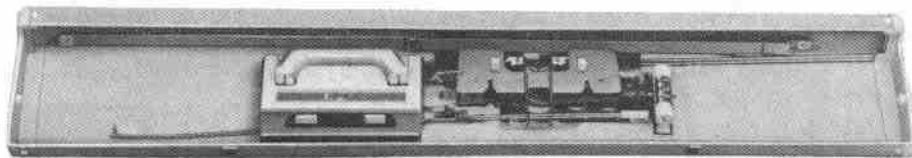

208



209

- (14) Close the carrying case.
(15) Lock the two catches.

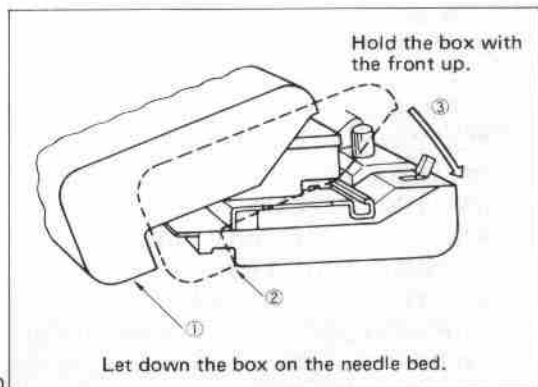

210

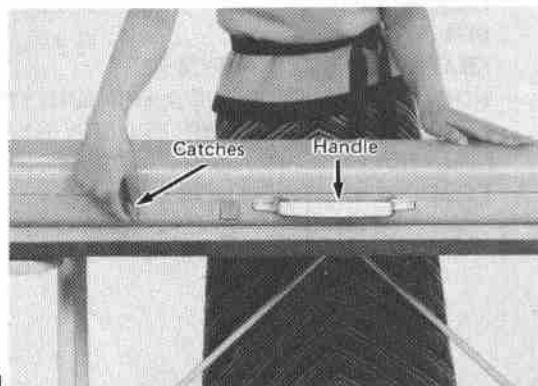

211

INDEX

NAME OF PARTS	1
SETTING UP YOUR MACHINE	3
Setting up the carriage	5
ASSEMBLING THE YARN TENSION	6
IMPORTANT POINTS TO REMEMBER BEFORE YOU START KNITTING	7
Winding the Wool	7
Tension dial and needle positions	8
FUNCTION OF THE CARRIAGE	9
PLAIN KNITTING	11
IF THE CARRIAGE SHOULD JAM AND HOW TO UNRAVEL A ROW	15
HOW TO USE THE NEEDLE SELECTOR BUTTONS	16
PATTERN KNITTING	18
Pull-up stitch pattern	19
Tuck stitch pattern	20
Fair-isle pattern	22
Weaving pattern	24
HOW TO USE THE L CARRIAGE	26
Lace pattern and Fine-lace pattern	29
Pull-up lace pattern and Woven lace pattern	31
PLATING YARN KNITTING	32
INTARSIA KNITTING	33
KNITTING A PLAIN HEM	36
KNITTING AN ELASTIC HEM	38
FINISHED EDGE CAST-ON	40
KNITTING A PICOT HEM	41
HOW TO USE THE TRANSFER TOOL	42
INCREASING STITCH	43
DECREASING STITCH	45
CASTING OFF	46
BUTTON-HOLES	47
SHAPING A "VEE" NECK	50
HOW TO CORRECT THE LACE KNITTING	53
REPLACING A BENT OR BROKEN NEEDLE	54
MAINTENANCE	55
FOLDING UP THE KNITTER	56