

# Let's start

## MACHINE KNITTING

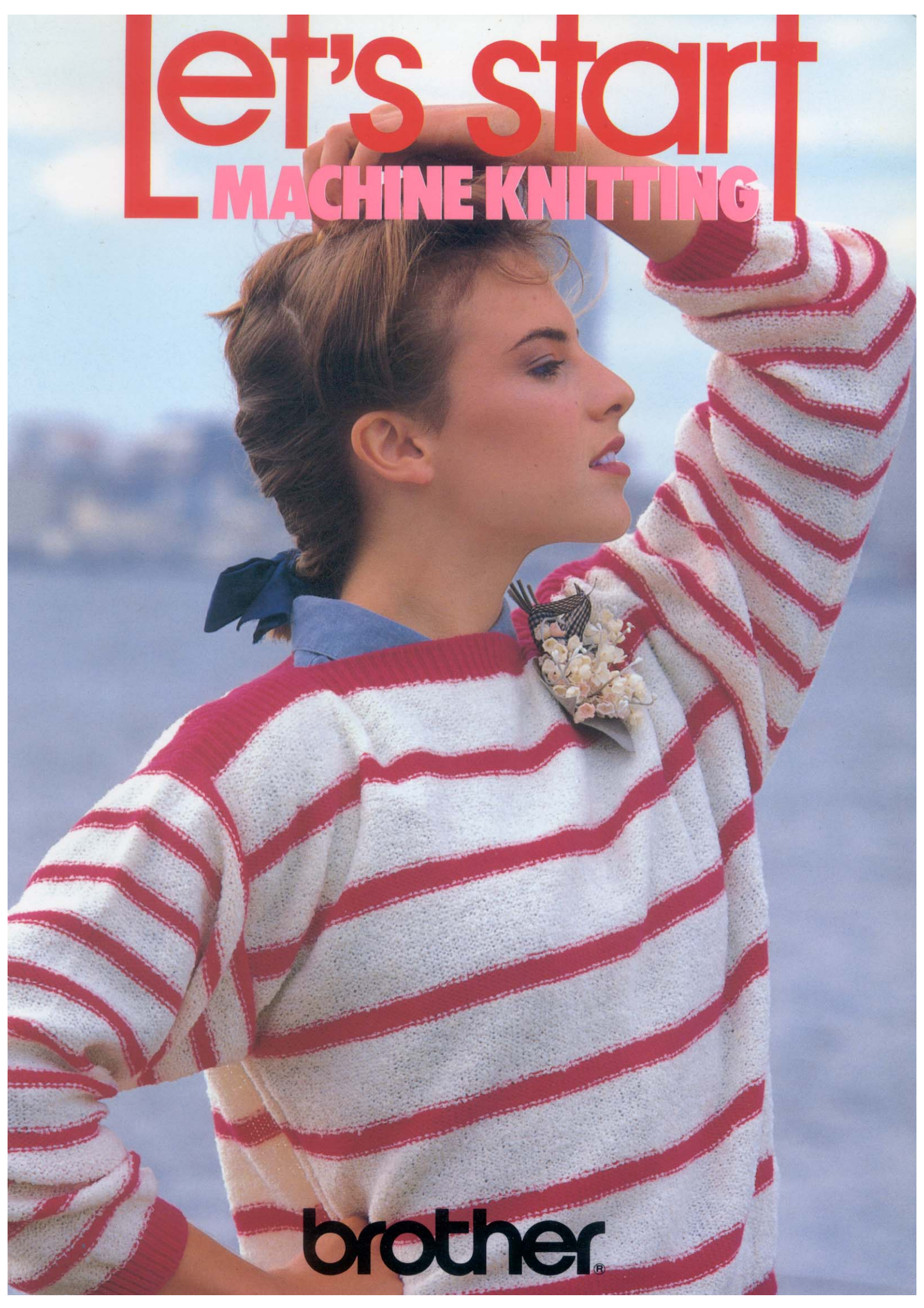

brother®

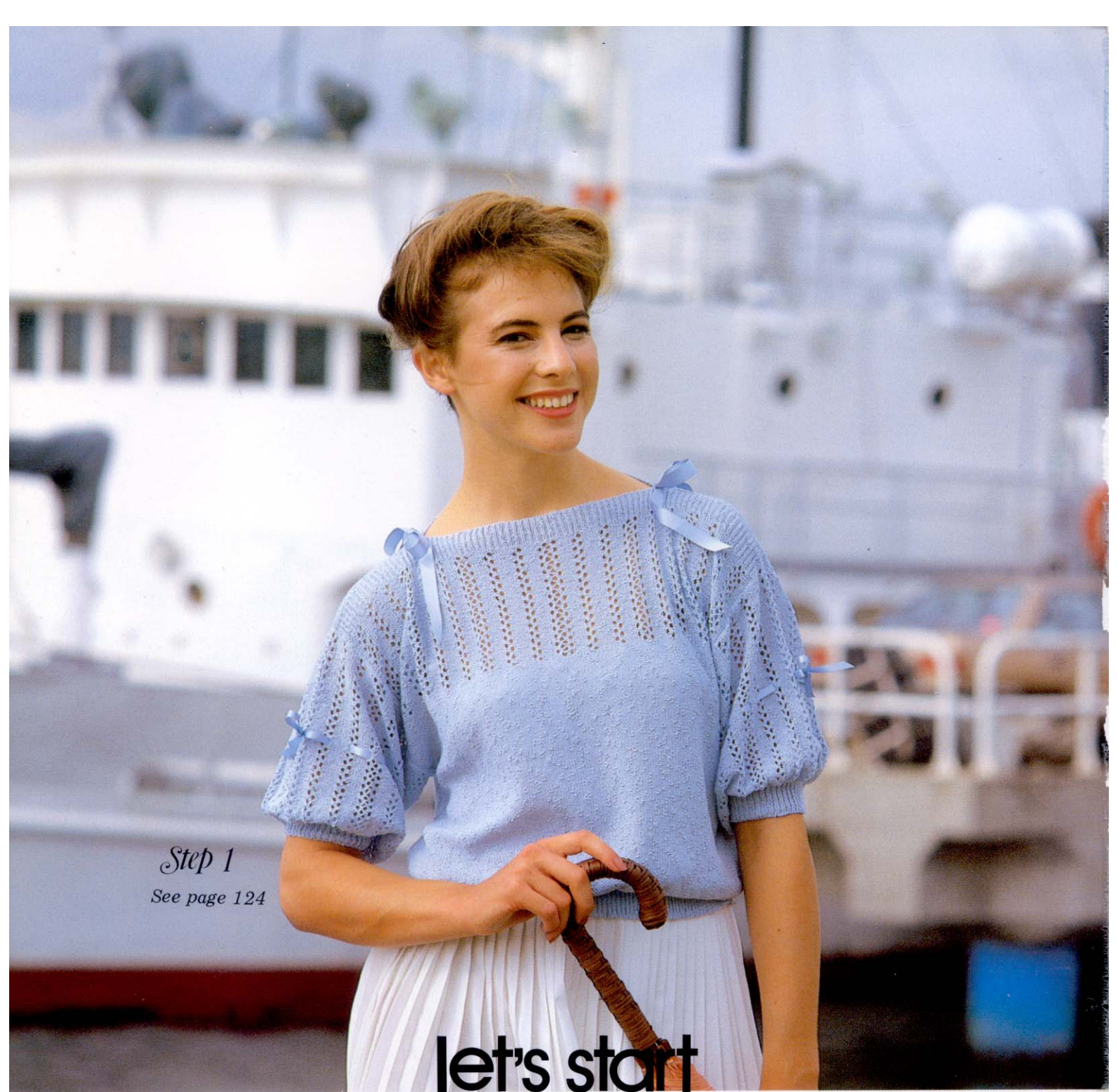

*Step 1*

See page 124

# Let's start MACHINE KNITTING

## Contents

Photo.....	2	How to make various garments ..... from the same pattern	124
Before you start knitting Let's learn!.....	11	Using the ribbing attachment (KR).....	138
<i>Step 1</i> Drop shoulder sweater.....	26	Pressing.....	142
<i>Step 2</i> A-Line skirt.....	44	Using a sewing machine for make-up.....	147
<i>Step 3</i> Man's slipover.....	54	How to wash knitwear.....	152
<i>Step 4</i> Lady's set in sleeve sweater.....	80	Making your own punch card.....	154
<i>Step 5</i> Child's sweater (Round neck with raglan sleeves).....	100	Making a stitch design for..... the electronic machine	156
<i>Step 6</i> Lady's cardigan.....	112	How to work 2×2 rib, using a latchet tool.....	157
		Index.....	158

# *Have a Nice Day*

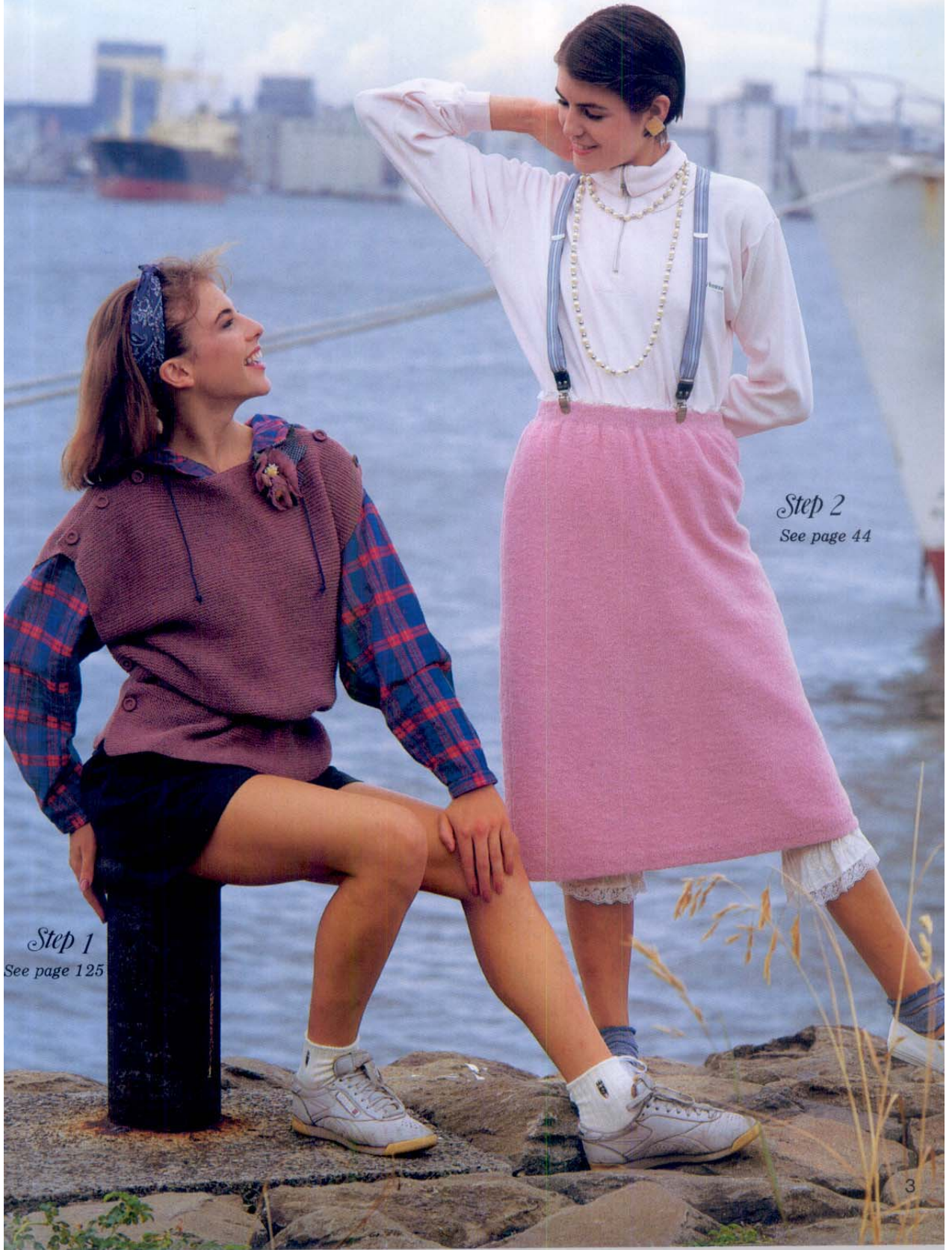

*Step 1*  
See page 125

*Step 2*  
See page 44



*Step 2*  
See page 126

*Step 2*  
See page 127



*Step 3*  
See page 129

*Step 3*  
See page 54

*Have a Nice Day*

# *Have a Nice Day*



*Step 4*  
See page 80

*Step 3*  
See page 128



*Step 4*  
See page 130

*Step 4*  
See page 131

# Have a Nice Day



*Step 6*  
See page 112

*Step 5*  
See page 133





*Step 5*  
See page 100

*Step 5*  
See page 132

# Have a Nice Day



*Step 6*  
See page 134

*Step 6*  
See page 135

# BEFORE YOU START KNITTING

## Let's learn!

Keep this book by you and refer to it often!



### 1: CONTENTS

#### Step 1

*Lady's Drop-shoulder Sweater*



Stocking stitch sweater — Back and Front Straight with shaped sleeves.

#### Step 2

*Lady's A-Line Skirt*



A semi-fitted skirt

#### Step 3

*Lady's and Man's Slipover*



V-Neck Slipover



To anyone who knits for the first time! It is important to learn the basic knitting techniques

Let's knit the garments from step 1 to 6 and master the techniques together!



I'm going to start with the easiest one...



#### Step 4

*Lady's Set-in Sleeve Sweater*



A standard round neck sweater with set-in sleeves

#### Step 5

*Man's and Child's Sweater*



A Raglan sleeve sweater — easy to make and easy to wear.

#### Step 6

*Lady's Cardigan*



Round Neck cardigan

## 2: PROCEDURE



Select the pattern you want to make.

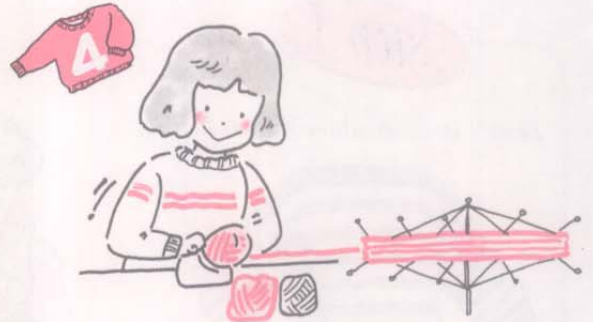

Prepare yarns.



Before you select the size, measure each part of the body.



Set up your knitting machine.

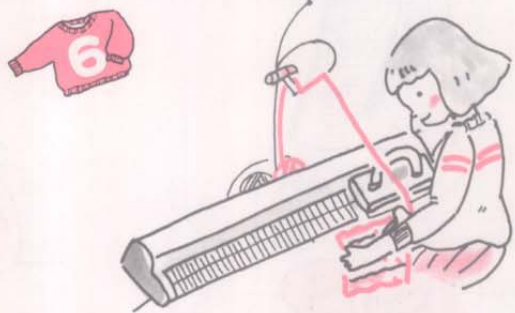

Knit a tension swatch.

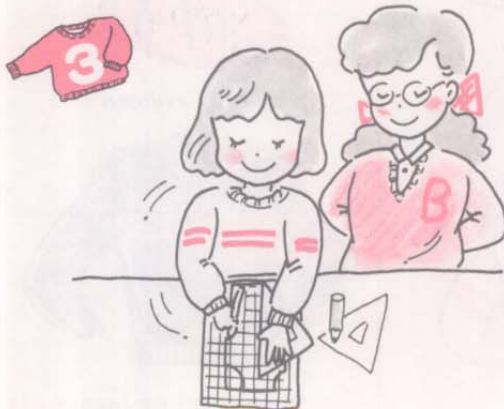

12 Trace the outline of the pattern onto paper or special sheet.



Take the tension gauge after you have pressed it lightly according to yarn label.



Set the Knit-leader according to the gauge.



Sew side and sleeve seams by hand or with a sewing machine.

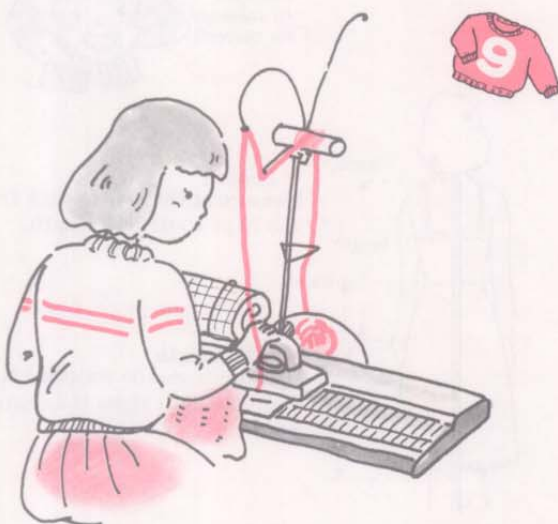

Knit the garment pieces.



Press lightly.



Block and press.



Your sweater is ready to wear!

### 3: WHAT DO I NEED FOR MAKING A GARMENT

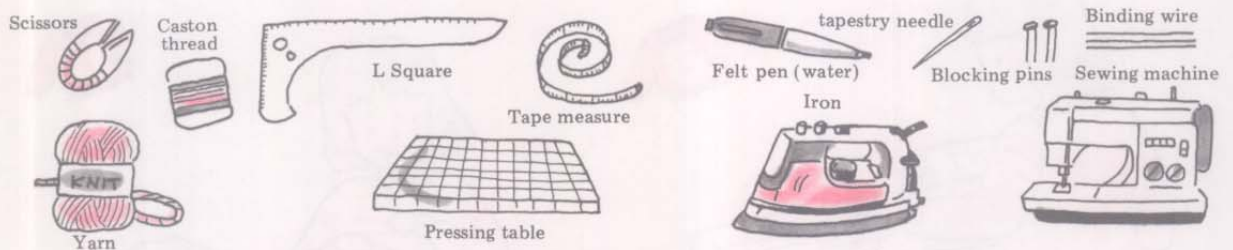

### 4: TAKING THE MEASUREMENTS



#### LADY'S MEASUREMENT

- **Bust (B)**  
Measure the largest part of the bust.
- **Sleeve length**  
Measure from the shoulder point to the wrist along the arm.
- **Waist (W)**  
Measure at the smallest part of the waist.
- **Hip (H)**  
Measure the widest part of the hip.

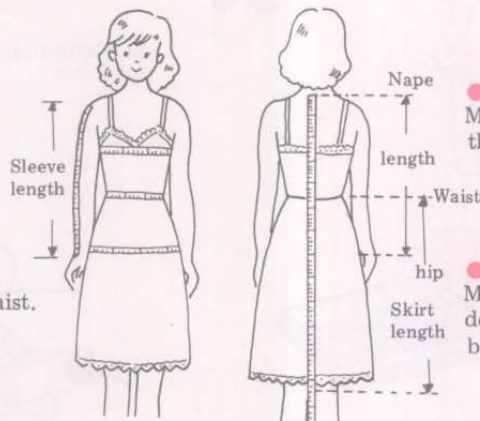

- **Length**  
Measure at the centre back from the nape to desired length.
- **Skirt length**  
Measure from the waistline to the desired length along the centre of back.

#### MAN'S MEASUREMENT

- **Chest (C)**  
Measure the chest loosely. Do not make it tight.

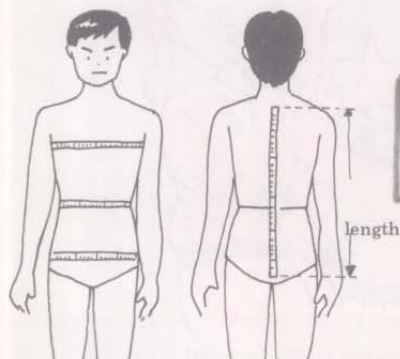

The other measurements for men and children are the same as the lady's.

#### CHILD'S MEASUREMENT

- **Chest (C)**  
Measure evenly around the chest putting 4 finger under the tape.
- **Waist (W)**  
As a child's waist is hard to find measure it approx opposite the elbow.

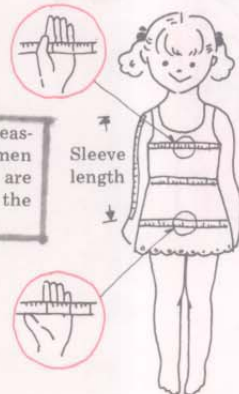



The base measurement of a slipover, sweater, dress or cardigan is the bust measurement. The base measurement of a skirt is the hip measurement.

## 5: SELECTING THE PATTERN

### ● Body Measurements ●

#### Lady's

Symbols	Bust	Waist	Hip
ES	81 - 86	60	86 - 91
S	86 - 91	65	91 - 96
M	91 - 96	70	96 - 101
L	96 - 101	75	101 - 106
EL	101 - 106	80	106 - 111

Unit = cm

#### Man's

Symbols	Chest
S	91 - 96
M	96 - 101
L <sub>1</sub>	101 - 106
L <sub>2</sub>	106 - 111
L <sub>3</sub>	111 - 116

Unit = cm

#### Child's

Symbols	Height	Chest
ES	104	58
S	116	62
M	128	66
L	140	70

Unit = cm

### ● How to select your pattern ●



As I like fitted one I'll choose a smaller size



I like a loose fit I'll take the larger one!

### ● How to adjust the pattern ●



When you want to change the garment length and the sleeve length keep the overall balance in mind.



When you have selected the S size but you want to change the garment or sleeve length adjust as shown below.

Bust size is S, but the garment and sleeve length are L.

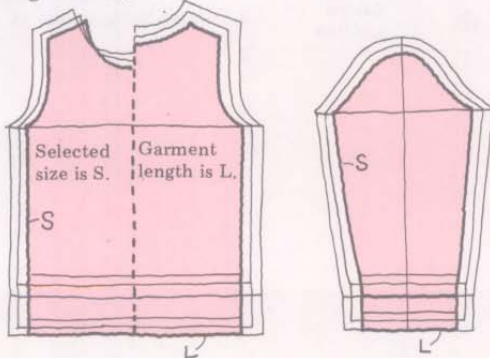

When you have selected the L size but you want to change the garment or sleeve length adjust as shown below.

Bust is L, and the garment and sleeve length are S.

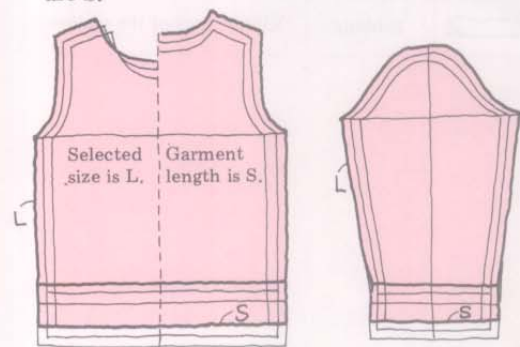

Should you select the S size but you want to make the skirt longer, adjust as shown below.

Waist is S size, skirt length is L size

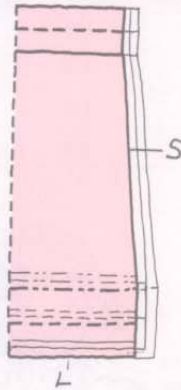

Should you select the L size but you want to make the skirt shorter, adjust as shown below.

Waist is L size, Skirt length is S size

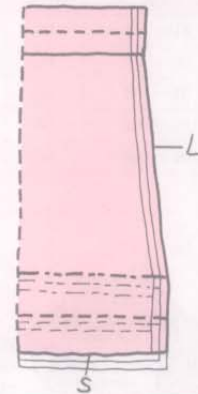

● Master the lines and symbols in the pattern ●

In order to make it easy to understand, symbols are used in the pattern!



As these symbols are very important remember them well!

Line	Name	Meaning
————	Finished line	Finished outline of the pattern
- - - -	Fold line	When the left side and the right side of the pattern are the same, only one side is drawn
— — —	Hem line	The hem from this line.
- - - -	Center line	The center of the pattern
▤▥▦▧▨▩	Ribbing	Ribbed part of the garment.

Line	Name	Meaning
↑	Direction of knitting	Represents the beginning of knitting and the direction.
▲	Matching marker	Matching point of the pattern.
~~~~~	Gathering	Position of gathering
⌋	End of opening	The end of opening
⊕	Button position	Shows the button position





What is the tension gauge?

In knitting the gauge means the number of stitches and rows to the cm.



In order to make a garment the correct size you will have to make a tension swatch and measure it!

## 6: Taking the tension gauge

### ● Tension Gauge ●



In order to knit a garment in the correct size, it is very important to have the correct gauge.

The results of the incorrect gauge.

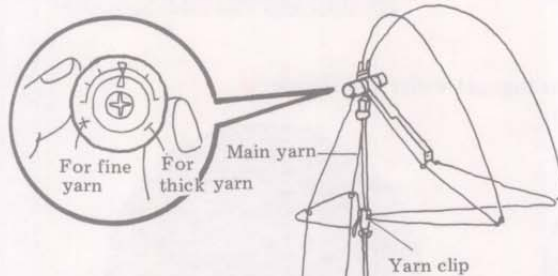

When the yarn does not come out smoothly turn the dial toward — mark. (Normal setting  $\times$  mark.)

There is a Tension Dial on the Carriage. You can change the size of stitch with the Tension Dial according to the thickness of the yarn.



By changing the tension setting on the Tension Dial, you can knit small or large stitches.

When you take a tension swatch, you need to set the Tension Dial according to the yarn and the kind of pattern you are knitting. Find the right Tension Dial number.

Table of Tension Dial in Stocking Stitch.



4.5mm Gauge	
Type of yarn	Recommended T.D. number
Very fine	1 - 3
Fine	3 - 5
Medium	5 - 7
Thick	7 - 9
Very thick	8 - 10



It may be very useful, make a note!

● When you take the gauge with pattern knitting ●

Plain stitch

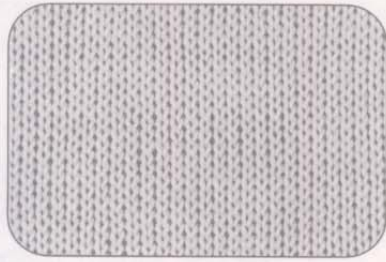

Stocking stitch

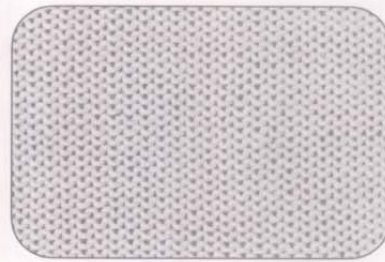

Purl stitch

● The stitch designs that get wider and shorder ●

Just keep this page in mind

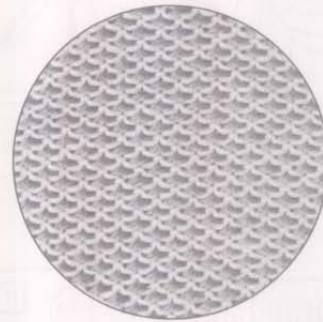
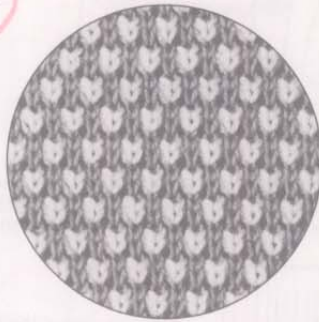

Tuck stitch pattern

Weaving pattern

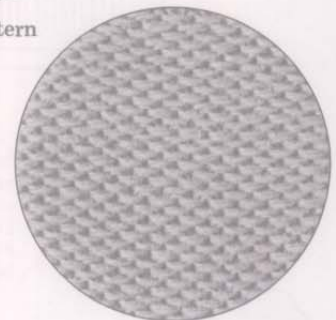
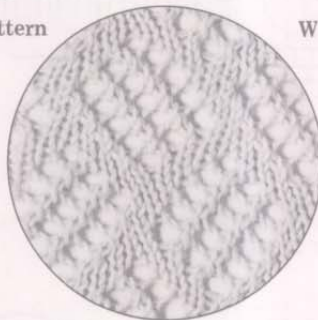
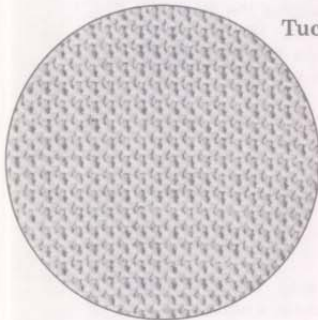

Garter stitch pattern

Lace pattern

Skip stitch pattern

● The stitch designs that get narrower and longer ●

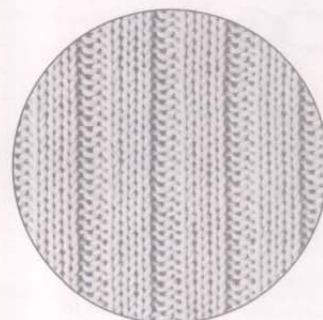
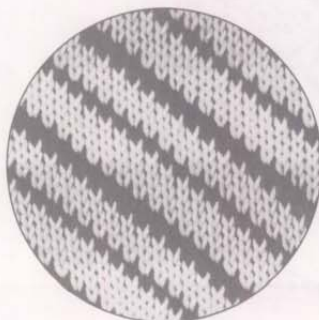

Fairisle pattern

Rib knitting



Now! From this page we are going to learn how to knit a tension swatch!

● Let's knit a tension swatch ●

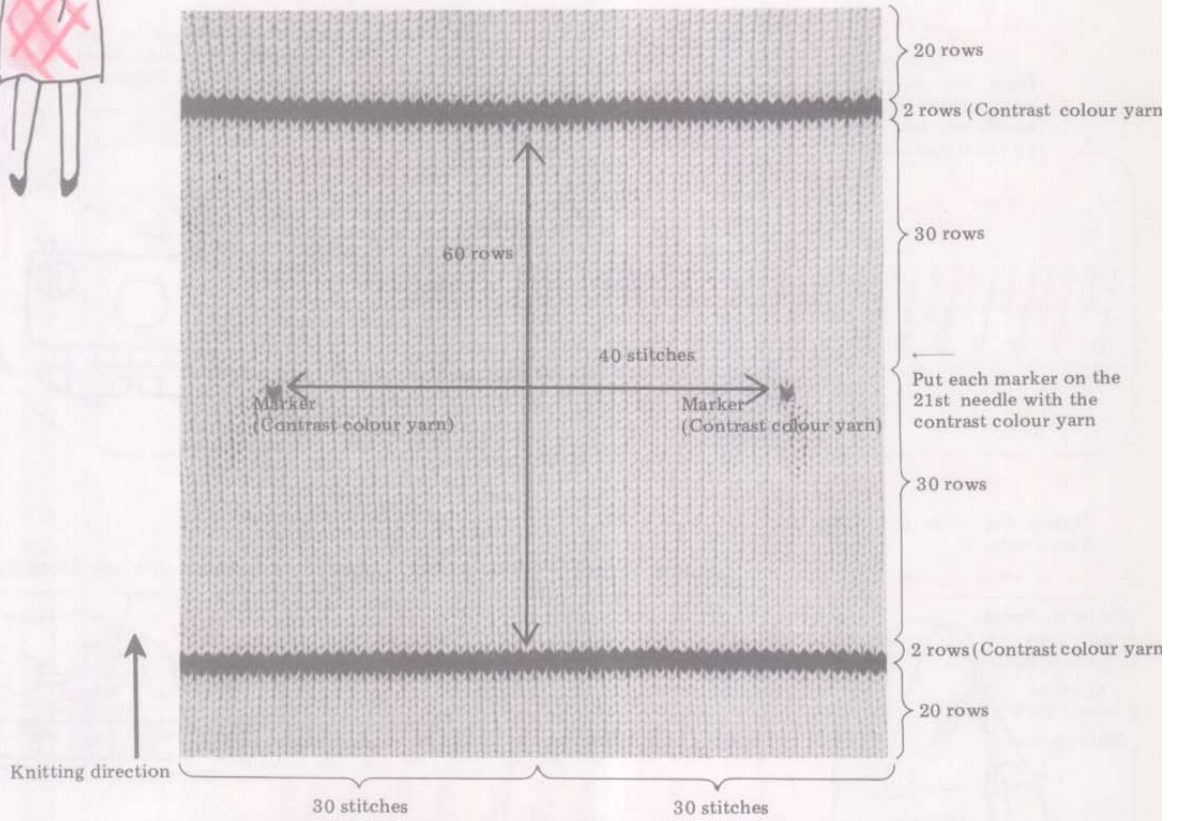

● For the garment in pattern stitches ●  
Take a tension swatch in the same pattern as you are going to knit the garment.

Set the carriage for stocking stitch. Thread the main yarn and the contrast colour yarn.

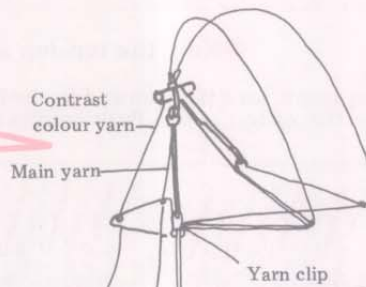

Insert your fingers into the centre of the yarn ball and pull out the end. Then it will come out smoothly. Or you can use a wool winder!



● Set the machine to take a tension gauge ●

Place the every other needle between the 30th needle on each side of "0" to B position,

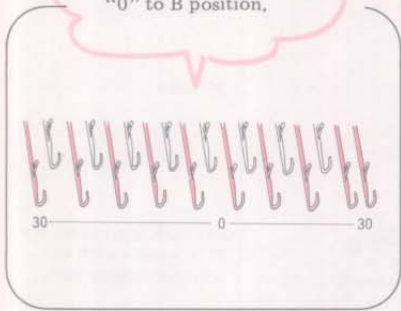

Place the carriage at the right side and push down the Row Counter Tripper.

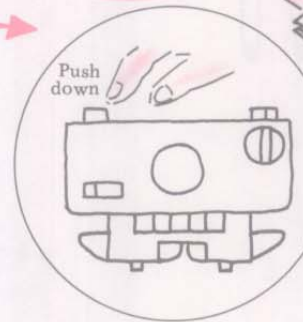
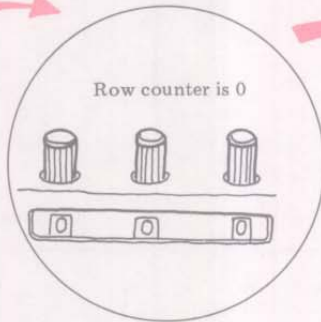

Thread the main yarn into the Yarn Feeder A

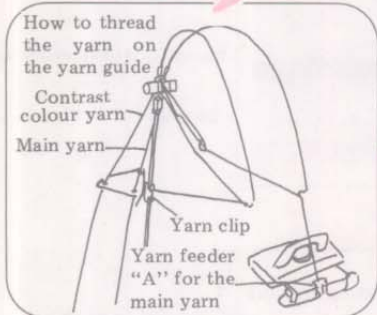

Holding the yarn end lightly with your left hand knit one row from right to left

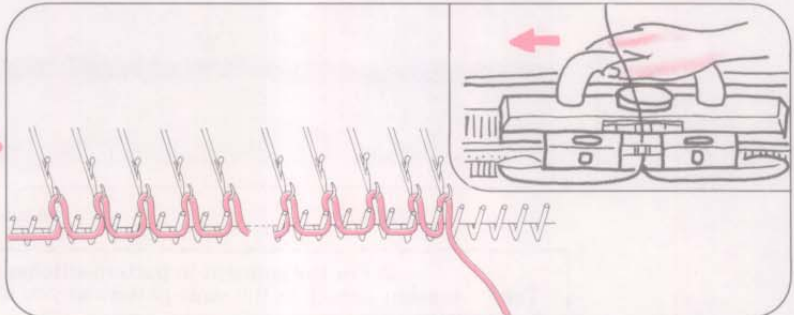

● Knit the tension swatch ●

Hang the caston comb, take the yarn end to the front and hook it under the yarn clip on the caston comb. Push needles in A position to B position.

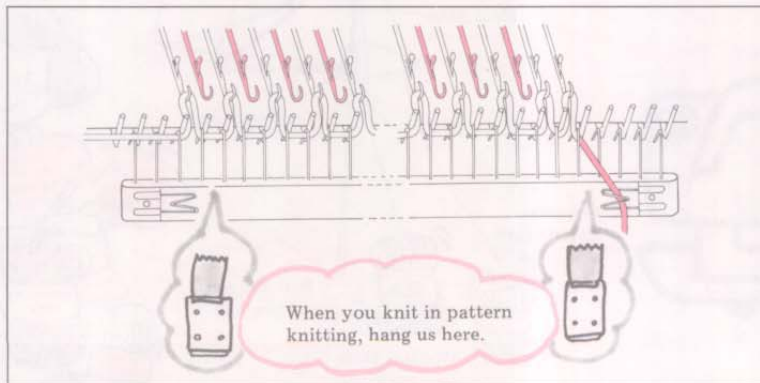

When knitting hang the claw weights on the caston comb.





Let's continue to knit!

Knit until the row counter is 020.

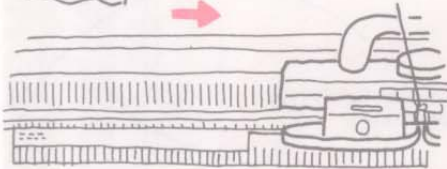

Knitting at a different speed can change the tension gauge so try to move the carriage smoothly.



Change the yarn to the contrast colour yarn.

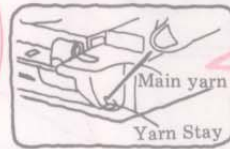

Put the released main yarn at the yarn stay at the right end of the knitting machine.

Knit 2 rows with the contrast colour yarn.

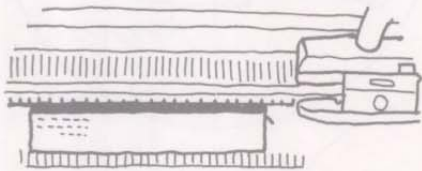

Row counter is 052

0 5 2

Knit 30 rows with the main yarn.

Cut 2 pieces of about 10 cm of the contrast colour and place a marker on the 21st needle on each side.

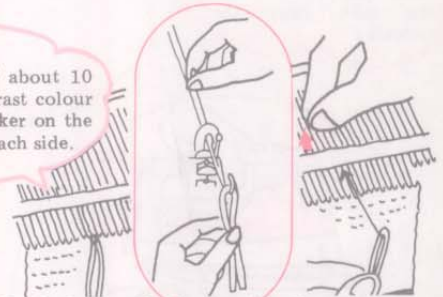

Push the needle forward to E position. Put a piece of contrast colour yarn over the hook and push the needle back to B position.

Row counter is 022

0 2 2



Knit 30 rows.

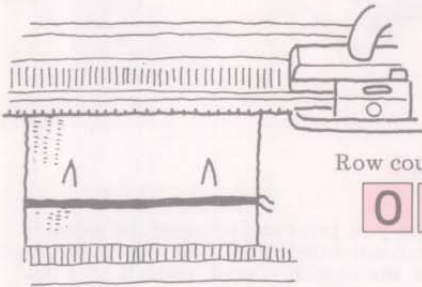

Row counter is 082

0 8 2

Knit 2 rows with the contrast colour yarn.

Row counter is 084

0 8 4

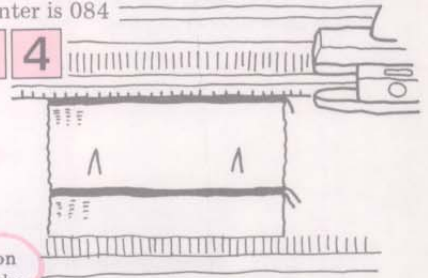

Knit 20 rows with the main yarn and break the yarn.

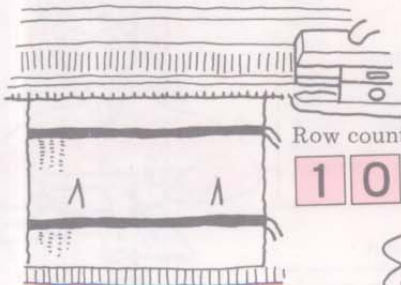

Row counter is 104

1 0 4

Remove the caston comb. Remove the yarn from the Yarn Feeder and move the Carriage across. Then the swatch is released from the knitting machine.



"Wow finished!"





CAUTION!  
Be gentle with  
Acrylics!

● Press the swatch ●

After release from the machine the tension swatch is often stretched sideways, pull it lengthwise 2 or 3 times to take away the stretch.

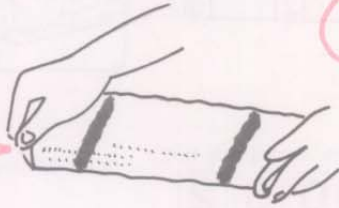

Pat the garment lightly your palm to make it even.



If the ends are rolled inside and you find it hard to make it settle, with the wrong side facing use the blocking pins to hold it in place before you press.

Never press the iron hard on the swatch.



● Measure the tension swatch ●

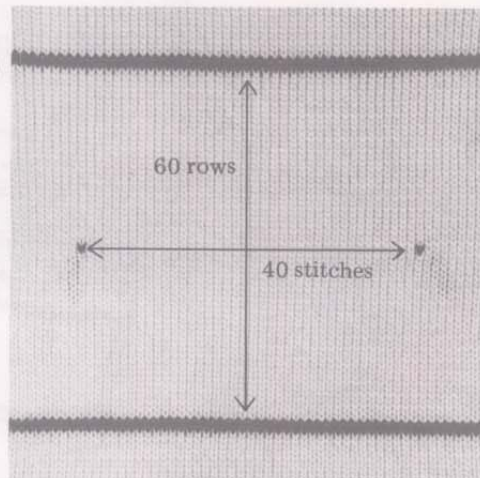
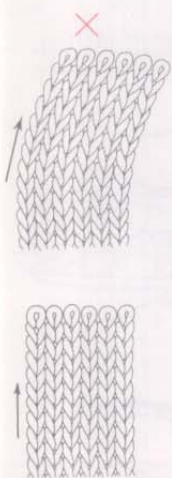

★ Before you press and measure the gauge it is recommended that you let it settle. After the swatch is cool, place it on a flat surface and measure it.

Measure it correctly and write down in your note book

● Length measurement

Measure 60 rows between the space from the 2 rows with the contrast colour.

● Width measurement

Measure the space from marker to marker for 40 stitches.





(Example) If you've got the tension gauge as below.  
60 rows = 13.8cm and  
40 sts = 12.8cm

How do you set the regulator?



● Set the Knit-leader for the tension gauge ●

Push down the clutch button and pull toward you.

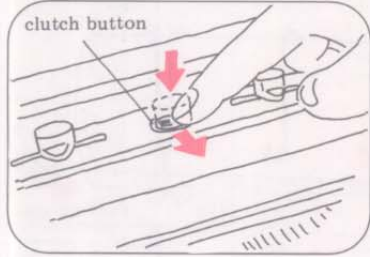

Set the left regulator to 13, and the right to 8.

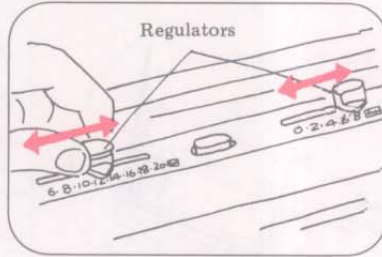

Push the clutch button to release it.

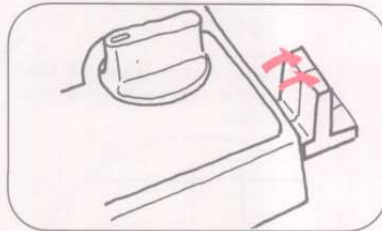
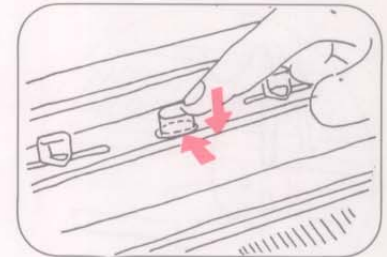

When you knit a garment, push the Knit-leader tripper into position.



The Stitch Scale is for the stitch measurement!

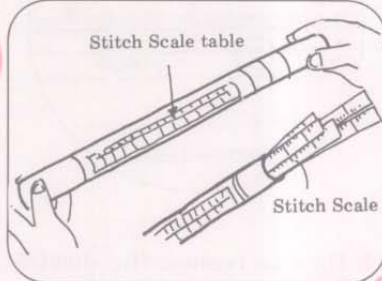

For 128mm (12.8 cm), see the column which shows the figure 128. You can see that 128mm (12.8cm) is under "No. 12".

● How to distinguish the Stitch Scale ●



Now you have learned all about the tension gauge.

There are 2 kinds of Stitch Scale: a) indicating the centre of garment piece to be knitted at the centre of the scale and b) indicating the centre of the garment piece to be knitted at the left, the b) scale may be turned upside down so that the centre line is at the right, garment pieces are drawn onto the Knit-leader sheet as required as shown above.

● How to set the Stitch Scale ●

Insert the Stitch Scale you have chosen into the slot for it with the correct Scale Measure facing you, and that the centre datum line is in the required position.

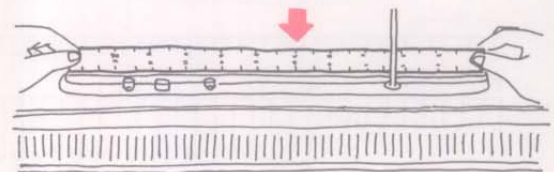
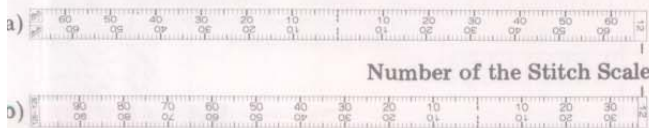

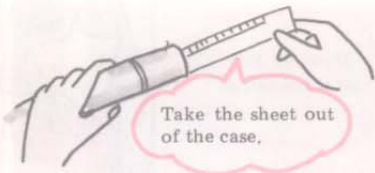

Take the sheet out of the case.

Trace your garment pattern on the sheet!



● Set the sheet onto the machine ●

① Insert the Sheet Guide into the slots at the back of the machine.



② After you have traced the pattern on the sheet insert it into the sheet guide.



③ Hold the left end of the sheet and fit the sheet's perforations over the teeth of the left feed wheel. Turn the feed dial a few pitches.

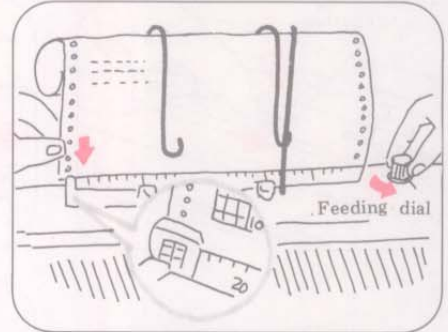

④ Push the sheet and move the right side of the sheet up and down until it is parallel.

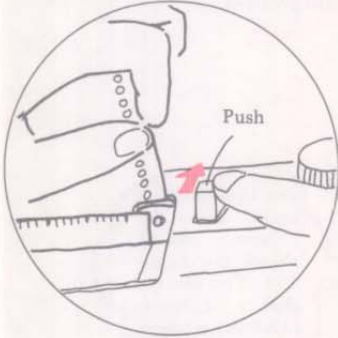

⑤ Match the centre line of the sheet to the centre line of the Stitch Scale.

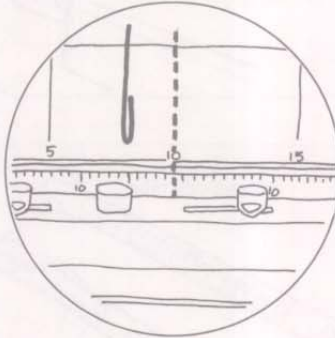

⑥ Set the base line of the drawing of the garment piece to the top of the Stitch Scale.

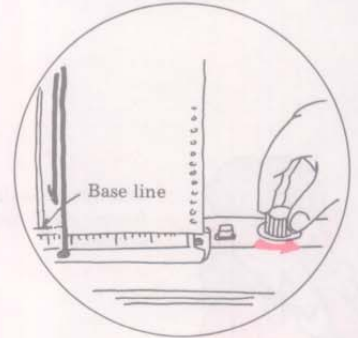

● How to remove the sheet ●



Push down the clutch button and pull out the sheet gently!

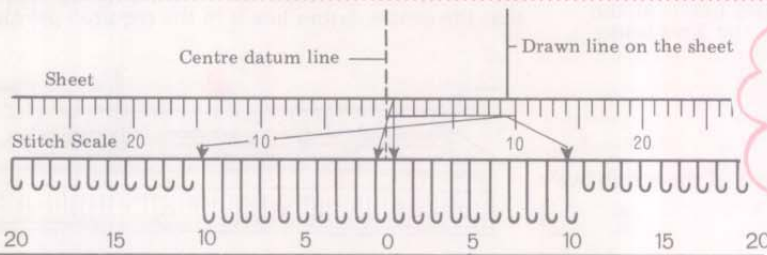
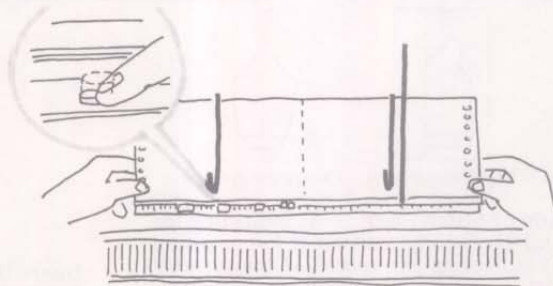

The number on the Stitch Scale corresponds to the number of needles. The diagram shows the Stitch Scale in relation to the needles.





# *Step 1*



# DROP SHOULDER SWEATER

Step 1

Use pattern No. 1

As the pattern has 5 sizes ES, S, M, L, EL take the correct measurements of your body and choose the correct size.



Please, check the tape is straight at the back.

Choose the correct pattern based upon your bust (B) measurements!



ES Size  
S Size  
M Size  
L Size  
EL Size



Decide the size of the pattern referring to your body measurements.

Size	Bust
ES	81 – 86
S	86 – 91
M	91 – 96
L	96 – 101
EL	101 – 106

## 1: TRACING THE PATTERN ON THE SHEET 2: THINGS YOU WILL NEED

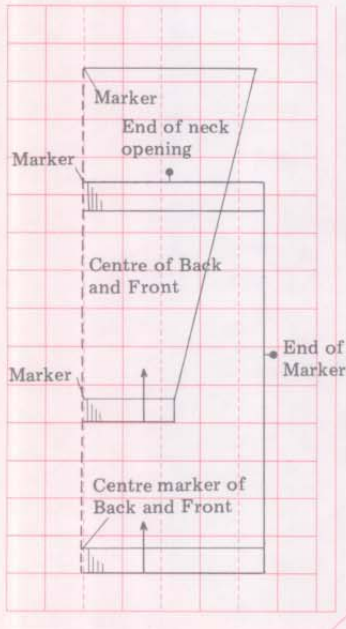

Remember to mark the pattern pieces as shown to make sewing easier!

Insert your fingers into the centre of the yarn ball and pull out the end. Then the yarn will come out smoothly, or use a wool winder!



### Approx Quantity of yarn used for close fitted stripe sweater

Size	Main yarn white (Boucle)	Contrast colour yarn pink (medium yarn)
ES	350g	100g
S	400g	100g
M	400g	150g
L	450g	150g
EL	450g	200g

Trace the patterns 5cm above the bottom of the sheet.

Each part is traced on the same sheet.

Are the Back and Front knitted the same way?



### 3: KNITTING POINTS

- ★ Knit the whole garments in stripes in stocking stitch.
- ★ The waistband, neckband and cuffs are knitted in 1x1 rib.
- ★ Be sure to place markers where necessary.
- ★ Sleeves are shaped by decreasing.

Before you start knitting keep these points in mind.

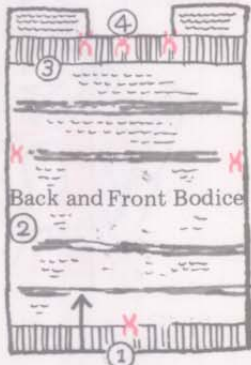

- ① Casting on using the ribbing attachment  
Cast on 1x1 rib. with the ribbing attachment. Always keep end needles on the main bed.

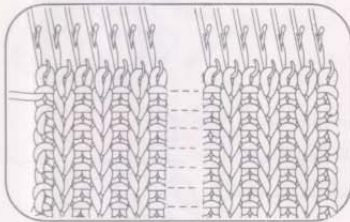

- ② Bodice  
Knit evenly up changing the yarn for the stripes and putting the markers where required.

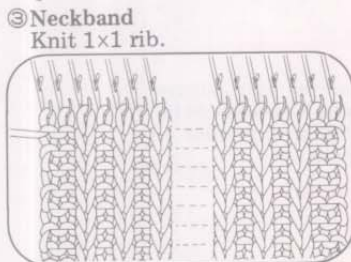

- ③ Neckband  
Knit 1x1 rib.

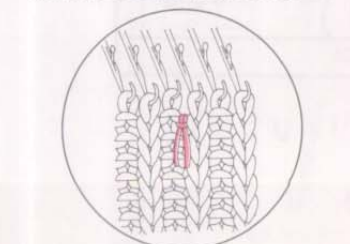

- ④ Markers  
Put markers at the centre and each end of neck opening.

- ⑤ Waste knitting  
Stocking stitch using an odd piece of yarn.

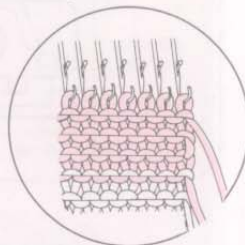

- ⑥ Joining of shoulders using a tapestry needle  
After knitting the back and front replace the stitches back onto the machine with right sides together, cast-off using a tapestry needle.

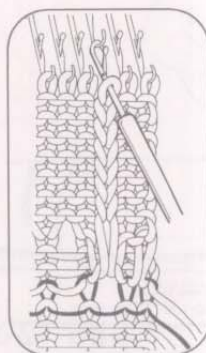
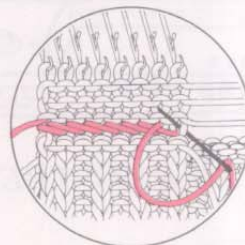

- When you are not using the ribber  
After waste knitting, knit the required rows in stocking stitch and make reverse on every other needle using a latchet tool as illustrated.

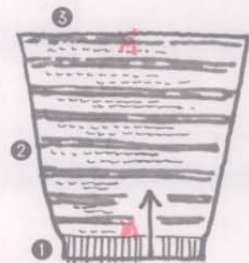

- ① Casting on with the ribbing attachment.  
Cast on using the ribbing attachment. Knit the cuff ribbing in 1x1 rib.
- ② Sleeve  
Knit from the cuff, working the stripes and increases as necessary.

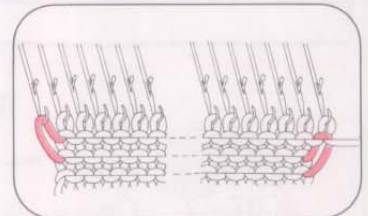

- ③ Attaching sleeves (on the machine)  
Pick up the stitches between the armhole markers. Place onto machine right side facing. With facing pick up stitches from top of sleeve and place onto same needles. Undo waste yarn and knit 1 row and bind off.





Always make a tension swatch!

#### 4: TAKING A TENSION GAUGE

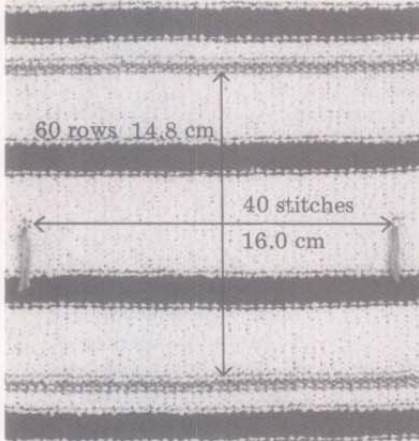

This tension gauge is only for this yarn and this Tension Dial!

Be sure to write down the measurements

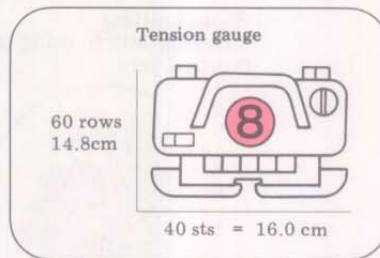

Set the left regulator to 14, the right regulator to 8

Stitch Scale

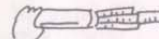

Choose the Stitch Scale for the left datum line

It's No. 17 scale for 159~161, isn't it?



#### 5: HOW TO KNIT THE BACK



Roll the sheet and set base of the garment piece to the top of the Stitch Scale

The number on the scale indicates 59. Bring forward 59 needles on the each side of "0" to B position on every other needle

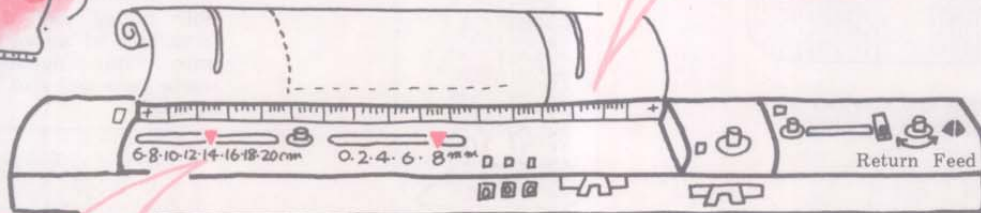

Does the dotted line on the scale and on the sheet match?

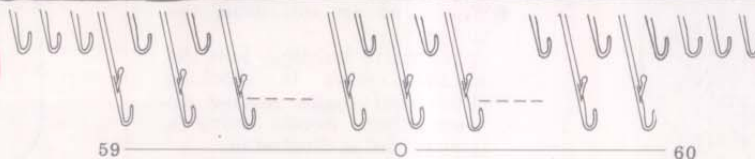



Referring to the Instruction Book for the ribber, set up the machine.

● Knit 1×1 rib with your ribber ●

Let's use looser Tension Dial in this case

(1) Set the carriage as below

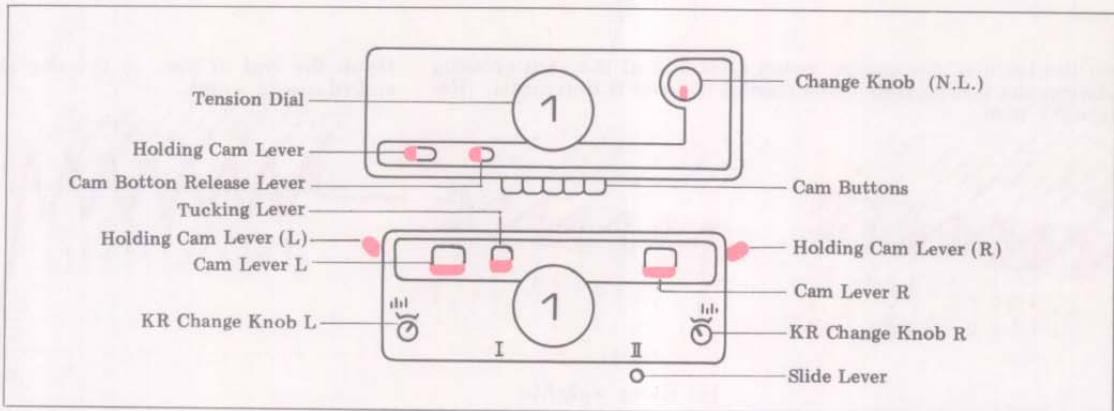

(2) Arrange the needles

Adjust the half pitch lever to P.



Set the racking indicator on No. 5.



By using the 1×1 needle pusher, arrange the required number of needles on the main bed to B position. Next arrange the needles on the ribber to B position as shown in the figure. (Ensure end needles are on main bed)



Operate the carriage 2~3 times over the needle bed to align the needles. Place the carriage to the right side.

(3) Cast on for 1×1 rib

Thread into the yarn feeder. By moving the carriage gently from right to left the needles on each bed will catch the yarn alternately.

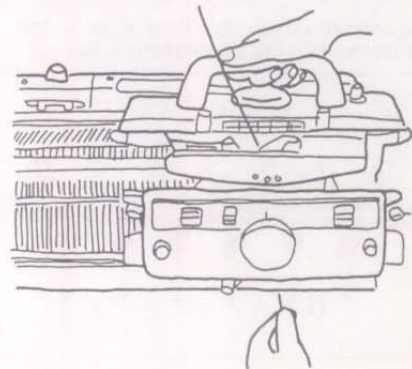
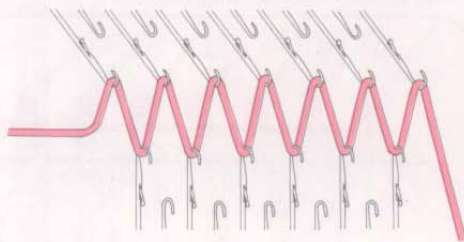

**(4) Hang on the cast on comb**

① Remove the wire from the cast on comb

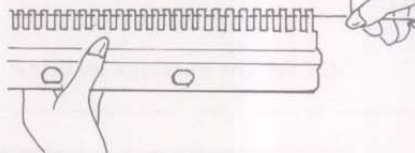

② Pass the teeth of the cast on comb each side of the yarn crossing between the needle beds being careful to keep it horizontal. Replace the wire.

Hook the end of yarn in the clip at the end of cast on comb.

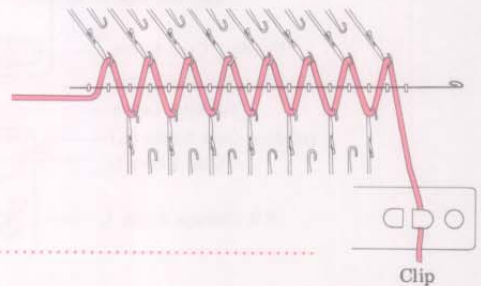
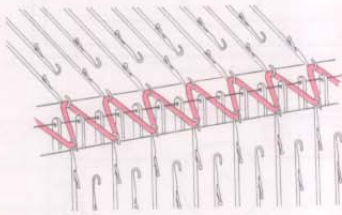
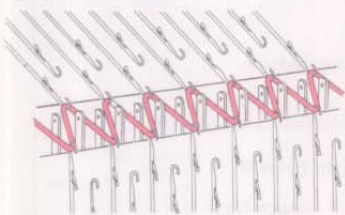

**(5) Hang weights**

Hang weights in balance using standard number of them. (2 big weights per 50 ~ 100 stitches)

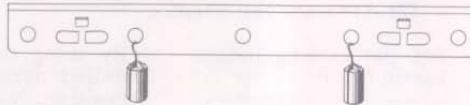

**(6) Finish the edge by circular knitting**

Set the carriages as shown in the below.

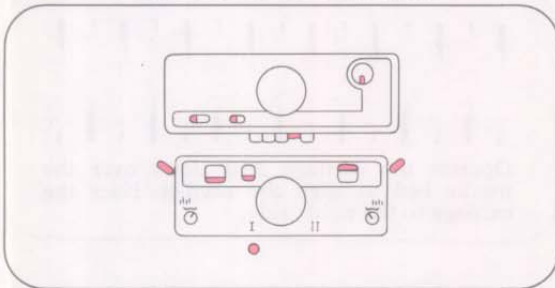

Move the connected carriage from left to right. (Needles on the main bed knit)

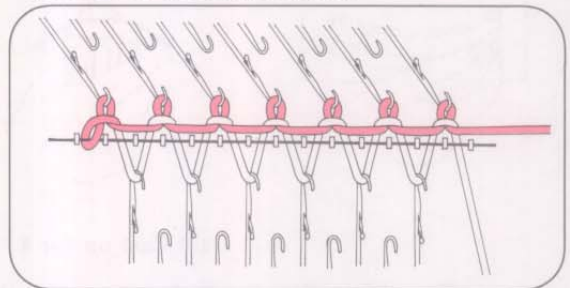

Move the connected carriage from right to left. (Needles on the ribbing attachment knit)

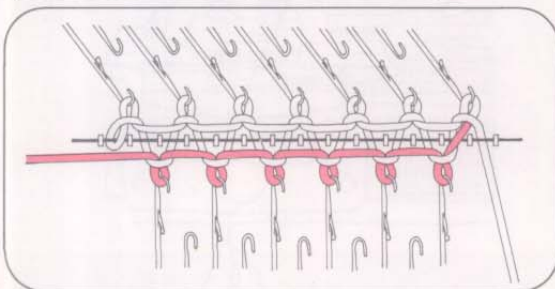

Move the connected carriage from left to right. (Needles on the main bed knit)  
The perfect edge is complete.

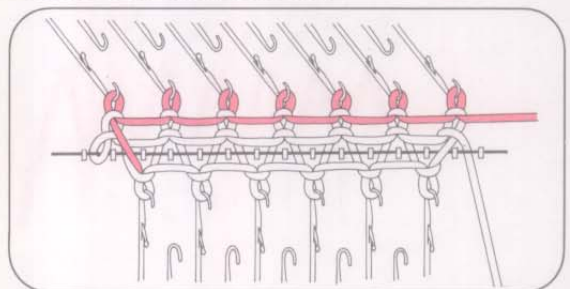

### (7) Knit 1×1 rib

Set the Row Counter at 000 and the carriages as shown below. Move the carriage until the Row Counter is 015.

Move the carriage until it passes over all the working needles before you return it, NEVER STOP THE CARRIAGE IN THE MIDDLE OF THE ROW.

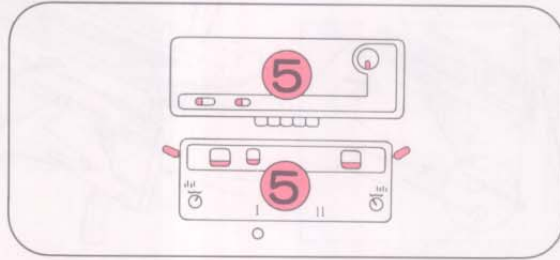

### ● Transfer the stitches from the ribber to the main bed ●

When you transfer the stitches from the ribber to the main bed use a transfer needle (an accessory of the ribber) or the transfer carriage which is sold separately.



The transfer needle is an accessory of the ribber!

For any one who has the Transfer Carriage, it will be very easy to transfer the stitches to the main bed.

#### (1) Transfer needle

Take a stitch on the ribber onto the transfer needle and carefully slide it down to the opposite end and slide it into the hook of the empty needle on the main bed as shown below. Push the empty needles on the ribber to A position.

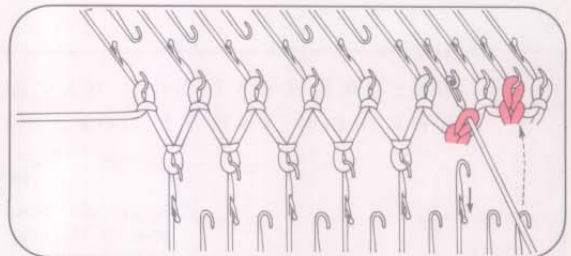

#### (2) Using the transfer carriage

★Let's read the instruction book well and transfer the stitches on the ribber to the main bed at one time.

① Push the needles forward to receive the stitches + a few at the right.

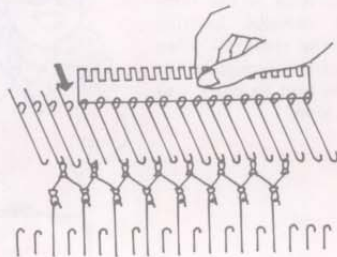

② Set the Change Lever of the Transfer Carriage to the lower position and operate it from right to left slowly by pressing it down gently.

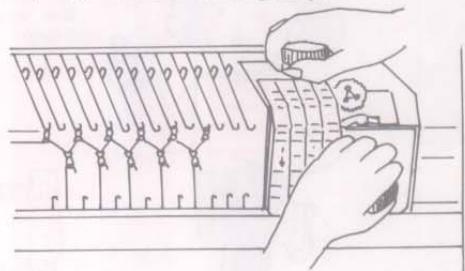

After the stitches on the ribber have been transferred, drop the ribber by using the bracket lever and remove the connecting arm assembly replace the sinker plate assembly.

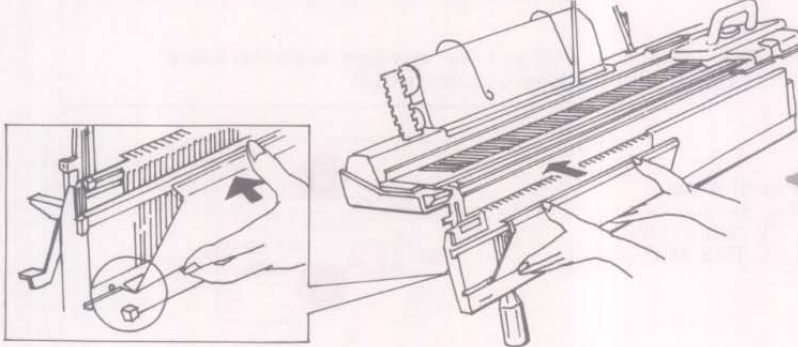

Use the ribber bed cover for protection of you and your machine.

When 1x1 rib is complete place a marker

Place a marker at the centre

How to place the marker

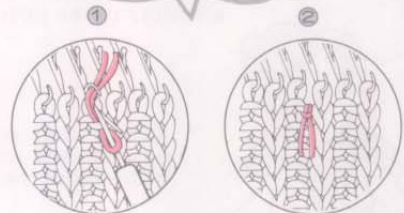
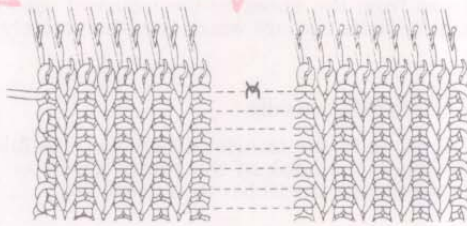

Pull through

ENSURE THAT YOU HAVE ENOUGH YARN TO COMPLETE THE ROW AND IT DOES NOT RUN OUT IN THE MIDDLE

Knot the your ends at the edge of the knitting.

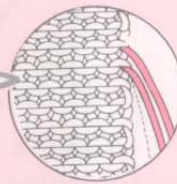

The next page is about waste knitting ....But what's waste knitting?

Waste knitting is the term used to describe knitting that will be removed when the garment is completed or to enable you to carry out the next step.





I must have a ribbing attachment as soon as possible



See page 33-34 for manual rib - using a latchet tool.

I'll explain this part

● How to work 1×1 rib ●

Read the required stitches on the Stitch Scale. Bring forward every other needle to B position as shown below.

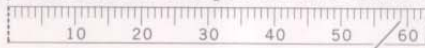

NOTE: the needle arrangement left and right ends are different.

Push out every other needle to B position.

● After waste knitting knit 1 row with the special caston thread ●

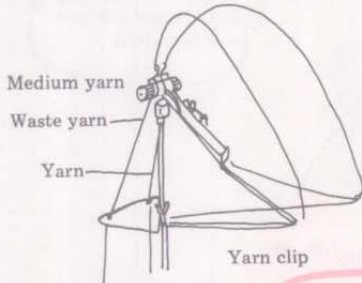

Thread the waste yarn into the yarn feeder "A".

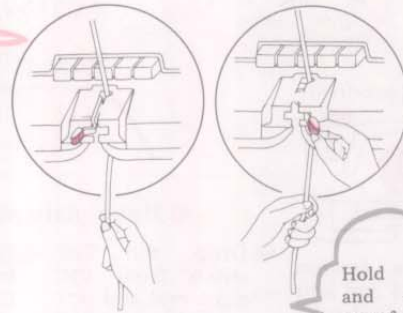

Hold the yarn and close the yarn feeder.

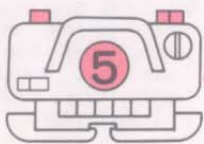

Set both trippers to non-working position (NWP)  
Set the Tension Dial to 5 or required tension setting.

① Knit 1 row to the left.

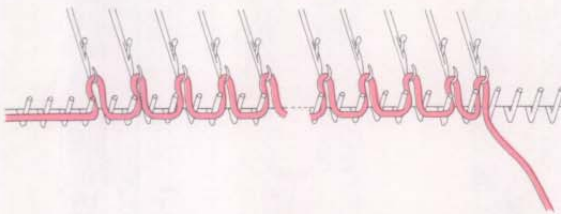

② Hang the cast on comb, and hook the yarn end in the yarn clip.

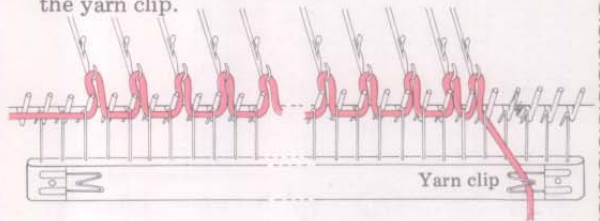

③ Continue to knit 9 rows, release waste yarn.

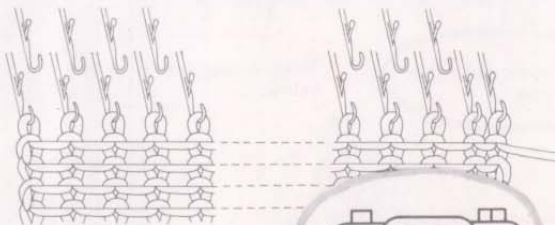

④ Knit 1 row with the special caston thread and remove it from the yarn feeder. Push both "PART" buttons and move the carriage without yarn to right side.

You'll find the special caston thread in the accessory box.

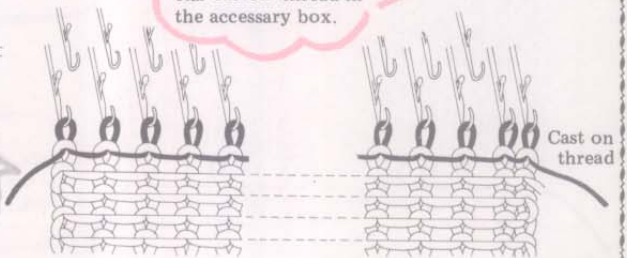



● Cast on 1×1 hem and knit the required rows in stocking stitch ●

① Set the Tension Dial to 2, or the required tension, and knit 3 rows with main yarn. Using the transfer tool pick up the right end needle.



Thread main yarn into yarn feeder "A" and knit three rows at the finished edge at a tighter tension

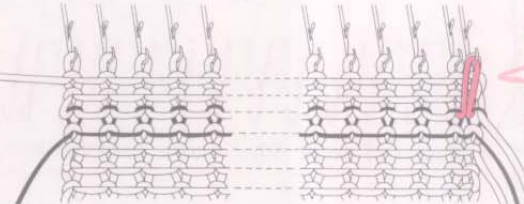

The sinker loop means the yarn between the needles

② Bring forward the A position needles to B.

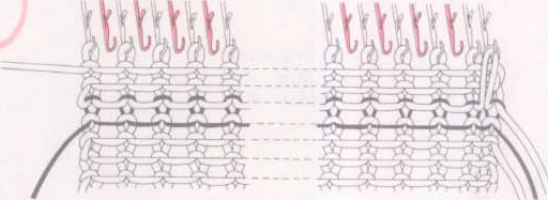

In case you are going to seam the sides by hand, leave the yarn end 50~60cm

Both trippers down



● Make plain stitches on every other needle ●

① Set the tension dial to 4 and knit the required rows for 1×1 rib.

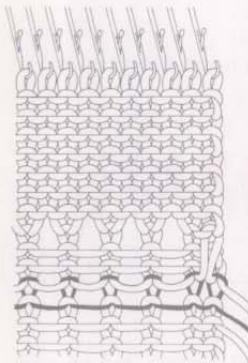

② Drop the 3rd stitch from the right end and unravel the stitches by using the tip of the latchet tool.

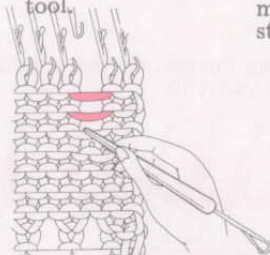

It seems awfully troublesome to work ribbing manually, but you will soon be accustomed to it

③ Insert the latchet tool under the first sinker loop and catch the 4th loop and using the latchet tool make a plain stitch.

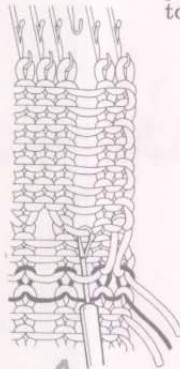

④ Push the latchet tool until the latch is open and previous stitch remains on the stem and catch the next loop and pull the latchet tool.

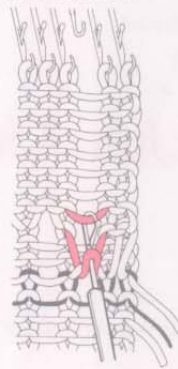

⑤ Repeat this until you reach the top, then hook the last stitch onto the hook of the needle.

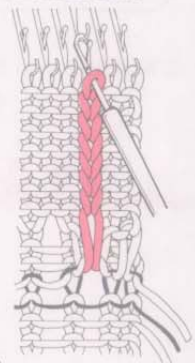

Skip 2 rows and catch the 4th one

Make a marker as shown below

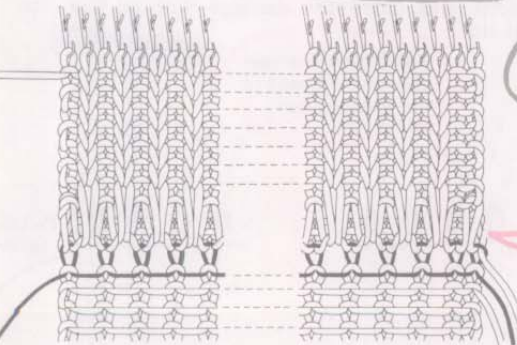

Place a marker at the centre of work

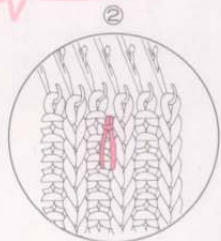
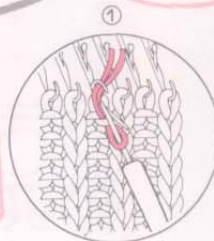

Just a moment!  
You can't knit yet!

● Knit until armhole ●



After the waist band is complete bring forward an empty needle to B position!

Empty needle on the left

Waistband ribbing

Empty needle on the right

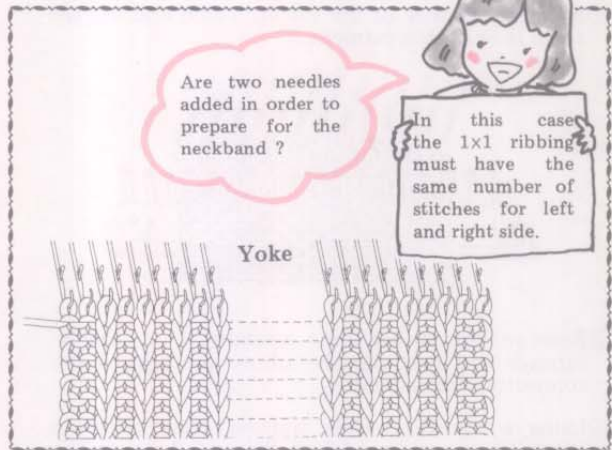
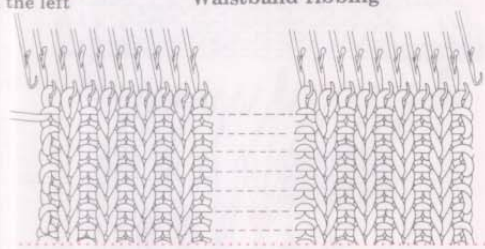

Are two needles added in order to prepare for the neckband ?

In this case the 1x1 ribbing must have the same number of stitches for left and right side.

Yoke



① Knit to underarm changing the yarn for stripes.

Set the Tension Dial to 8 and working in stripes knit to underarm

Knit in stripes as below

Contrast colour	8 rows
Main yarn	20 rows
Contrast colour	8 rows
Main yarn	20 rows

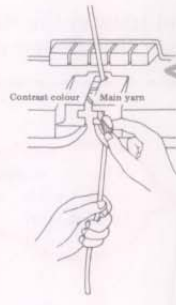

When you replace the yarn make sure it is securely in the yarn feeder



Both trippers down

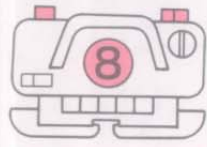

② Be sure to put markers at each side of the garment, since the sleeves are attached from the marked position.

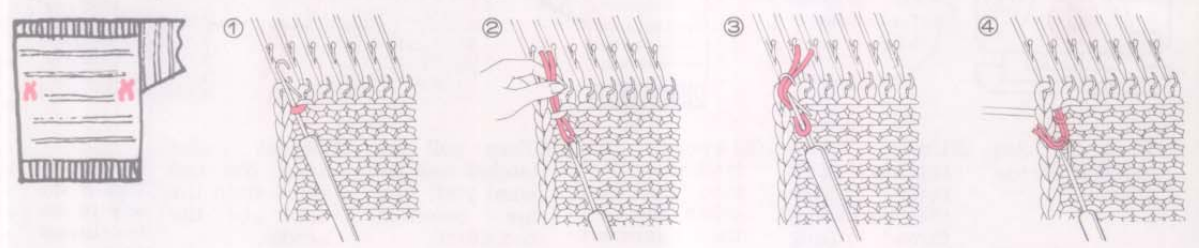

● Knit to the neckband ●



After you have put the markers at armhole position continue to knit in stripes to neckband.





● Knit the neckband on the ribber ●

① Remove the wire of the caston comb and put the teeth through the garment.

② After making sure the teeth of the caston comb are through the garment, replace the wire and hang on the weights.

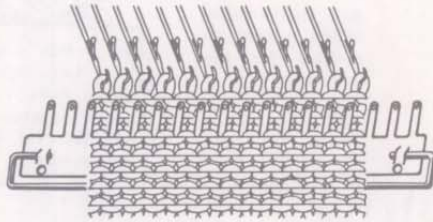

③ Remove the sinker plate assembly from the K-carriage and push up the ribber and replace the connecting arm assembly.

④ Using a transfer needle transfer every alternate stitch to the ribber. Leave the end 2 sts on the main bed.

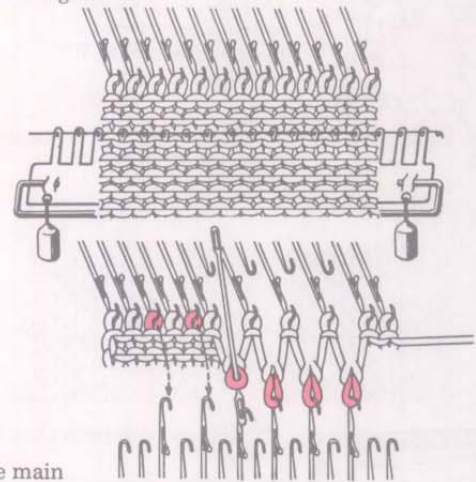

Knit 15 rows in 1x1 rib and transfer the stitches on the ribber to the main bed by the transfer needle or the transfer carriage.

● Using a latchet tool ●

Who wants work with a latchet tool

Put the marker here again

Using a length of contrast colour work along the row as illustrated

Both trippers down

For neckband Tension Dial to 4

① Drop the 3rd stitch from the edge.

② Undo the stitches 2~3 rows above the horizontal thread using the end of the latchet tool.

③ Insert the latchet tool into the 2nd stitch and pull the garment down with your left hand and catch the yarn crossing above in the hook.

④ Then pull the latchet tool toward you. You are reversing the stitch.

⑤ Repeat and hook the last stitch onto the hook of the needle.

This is the way to use the latchet tool!

From here onwards both latchet tool and ribber users work together!

● Place a marker at centre and both ends of the neck opening and finish the stitches using a tapestry needle ●

Place markers and castoff the stitches using a latchet tool



Put a marker at 28th stitch at left and 27th stitch at the right and at the middle. The same number of stitches must remain for each shoulder.

28 ← centre → 27

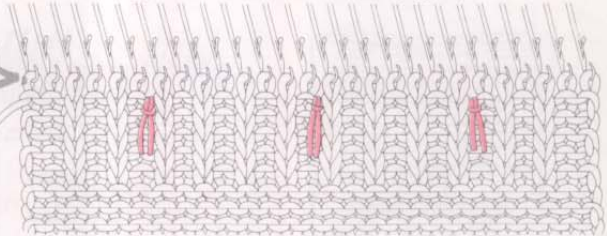

● How to place the markers at the centre and the ends of neck opening ●

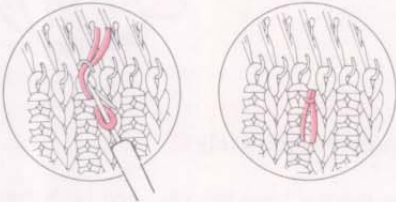

● Bind off using a tapestry needle ●

Allow (3 times of the width of knitting on the machine) to finish off by binding method.

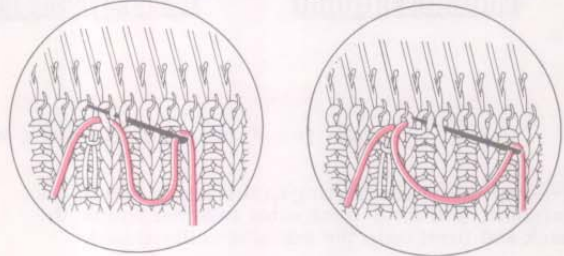

Stitches are still on the needles.

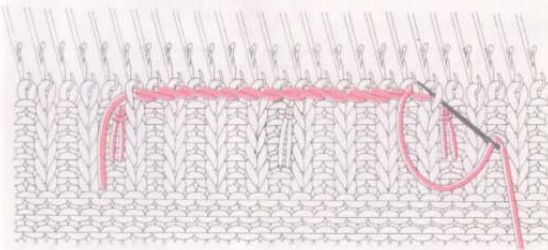

Bring forward the needles with the bound stitches to E position, Push them back to A position and release work from the machine.

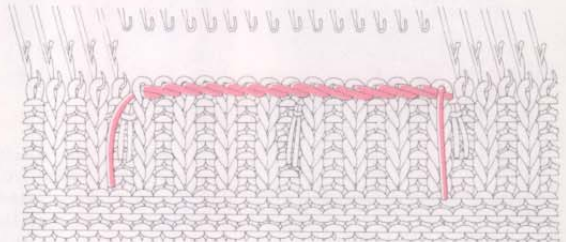

● Waste knit and remove both shoulders from machine ●

Change to waste yarn and knit 10 rows on both shoulders

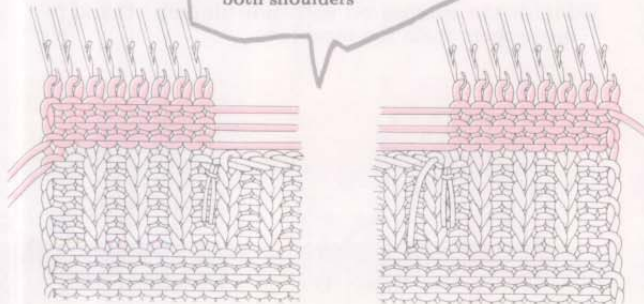

Take yarn out of the yarn feeder. Move the carriage without yarn, and you can remove the knitting from the machine.

Wow! The back is finished!



The front is worked same as for the back. Go ahead!

## 6: THE FRONT



After you have finished knitting the front, place markers and leave it on machine.

Wow! The second piece was finished so easily!

### ● Join the Front and the Back work each shoulder separately ●

① Folding the waste knitting to the wrong side of the garment, and with right sides together, hook the back and front onto the machine as illustrated.

② After all the stitches have been hooked back, bring forward the needles to E position. (In order to make knitting easy) Knit the right side from the right side. Pull out the yarn from under the carriage and make a loop of about 70 cm.

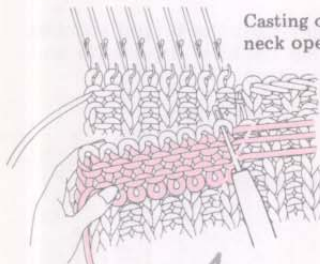

Casting off sets of neck opening.

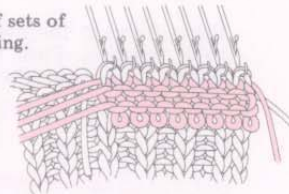

Fold the waste knitting toward you to make the work easy.

Replace the stitches of back and front onto each needle right sides together and finish off with a tapestry needle.

Needles in E position

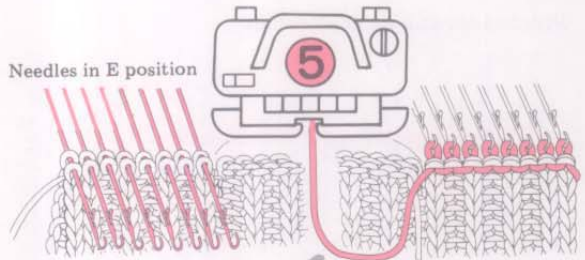

The yarn end is used to finish the stitches by binding off.



③ Knit 1 row on the left side and cut yarn leaving about 50 cm. Next, knit about 3 rows of waste knitting to make binding off easier.

④ Finish the stitches on each side binding off and remove them from the machine.

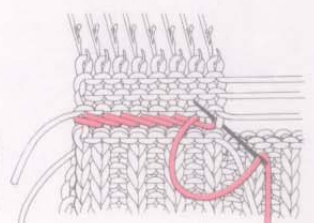
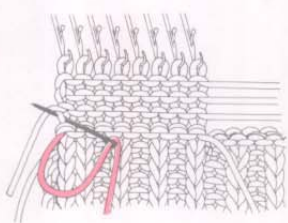
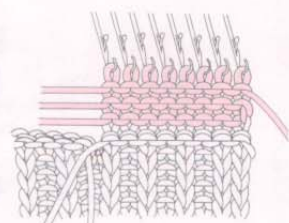
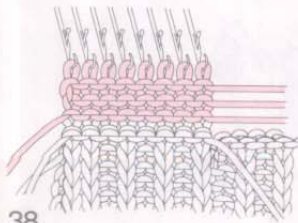

Stripes of sleeve

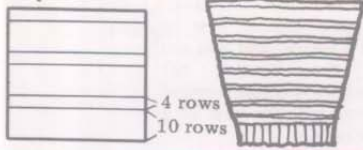

Now knit the sleeves



## 7: KNITTING THE SLEEVES

① Read the number of stitches for the cuff on the Stitch Scale and arrange the needles in B position.

The number on the scale indicates 30, arrange 30 needles on each side of 0 in B position.

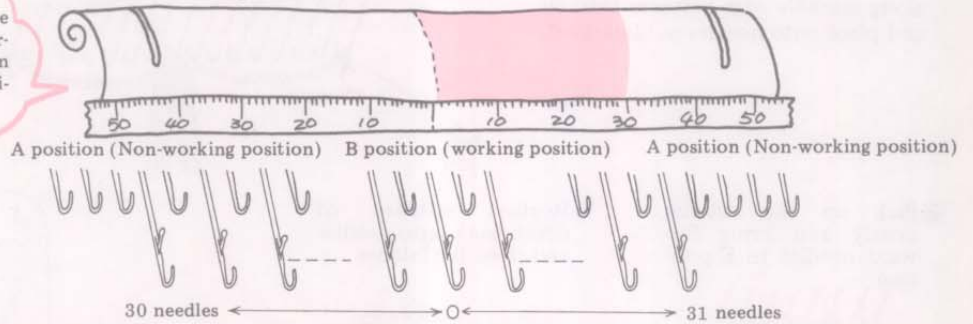

### ● Knit cuff using the ribber ●



Knit as waist band ribbing see page 29-31

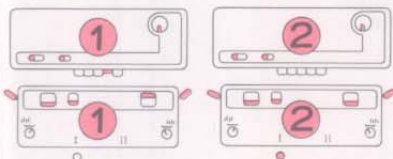

● Finished edge circular knitting ●

● 1 x 1 rib ●

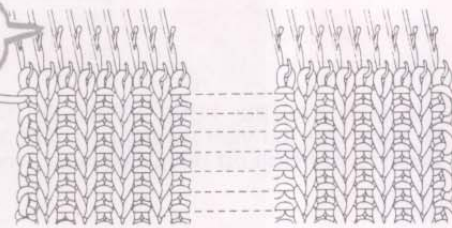

If you are using the latchet tool see page 33-34



### ● Knit the sleeves ●



After the ribbing is complete, the Knit leader indicates as below.

After 1 stitch has been increased the Knit leader indicates as below.

Place the next empty needle to B position to increase stitch change yarn, working in stripes continue to knit sleeve.

Both trippers down



Place the yarn into the yarn feeder.

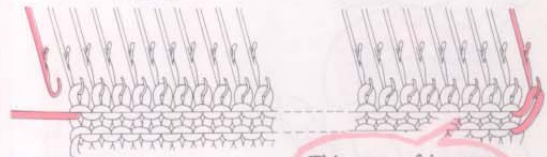
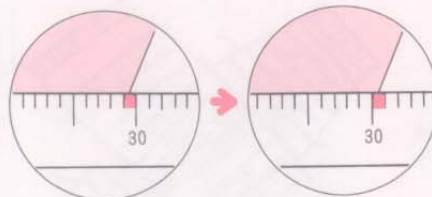

This way of increasing stitches is recommended only when using a sewing machine

When using mattress stitch this method of increasing is recommended.

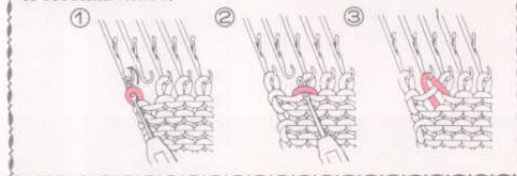

When the sleeve is complete waste knit and remove from machine. Knit the second sleeve in the same way but do not waste knit.





Wow! I've finished knitting!  
When you knit 1 row to attach a sleeve and you are using the binding off method, it is recommended that you knit the row at a tighter tension

● Attaching the sleeves ●

① Leaving the needles on which you have been knitted the sleeve in B position, pick up the stitches evenly along armhole edge between markers and place onto needles as illustrated.



② Pick up the stitches evenly and bring forward needles to E position.

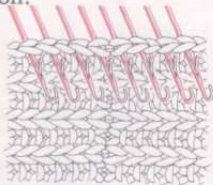

③ Replace stitches of sleeve back onto needles and close the latches.

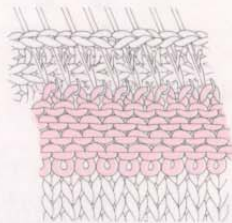

Push the needles back to B position holding the garments in your hand

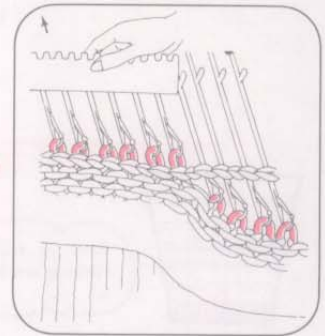

TO MAKE KNITTING THE NEXT ROW EASIER, PUSH NEEDLES INTO E POSITION Knit 1 row from left to right. Cut the yarn leaving an end of 3 times width of garment. Knit 3 rows in waste yarn. Finish off using a tapestry needle.

8: FINISHING

● Sew in yarn ends before pressing ●



Using a tapestry needle take yarn along the side of knitting as illustrated.



Let's keep the yarn ends of ribbing for sewing

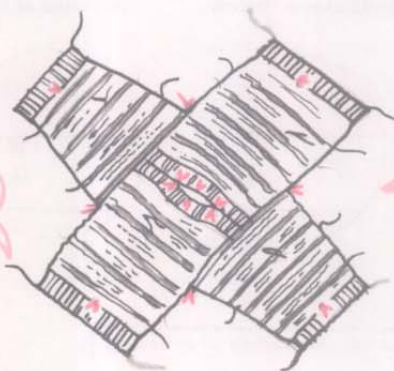

Leave the markers as they are



● Block and press ●

● Utensils to have ready ●

In order to have a well shaped garment press each piece out to the shape of the original pattern.

The edges of a garment are apt to stretch slightly, so thread them with the wire as shown then press.

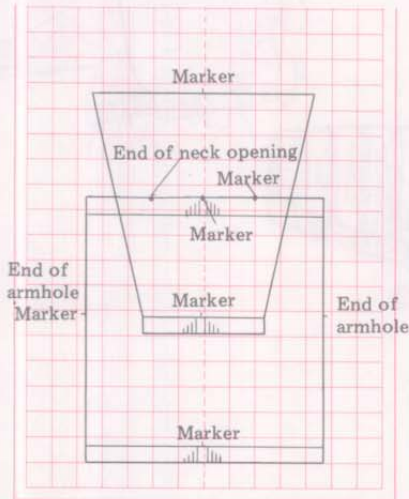

Trace the pattern on a paper.

Let's have ready an iron, pressing table, pins, binding wires from Knit-leader.

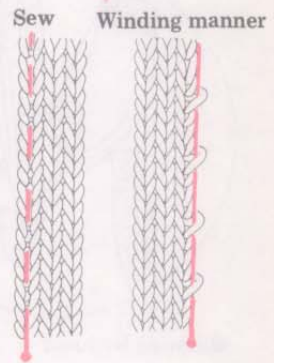
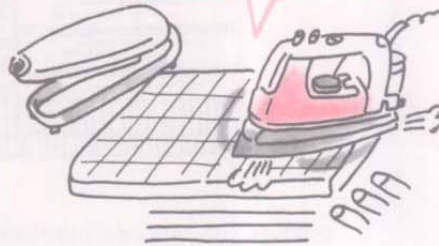

① Place the paper onto the table and pin the garment piece onto the paper.

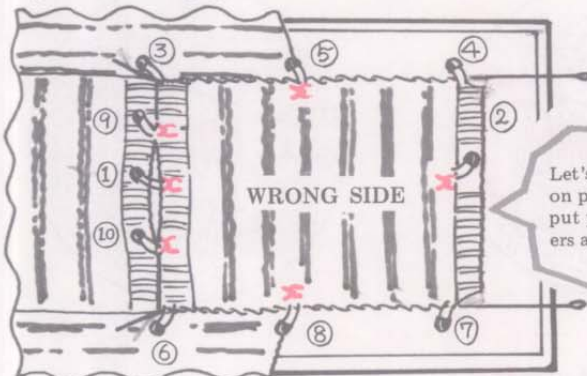

② Place pins at intervals of 10-15cm, and press avoiding the ribs.



Block and press all garment pieces





Be careful to match the stripes when you sew the sides and sleeves



### ● Seaming ●

When using a sewing machine, place right sides together and thread the binding wire evenly along the edge. Using a sewing thread baste into position, then you are ready for the sewing machine.

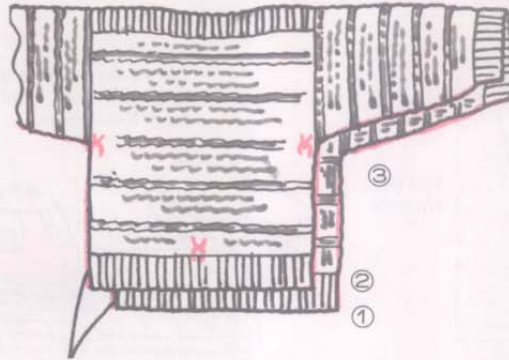

#### ● Sewing by hand

① Thread a tapestry needle and sew as the diagram below.

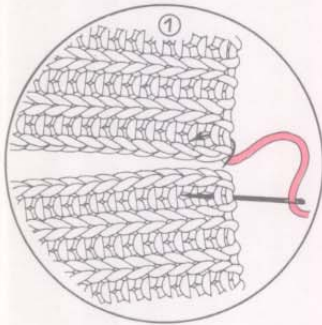

② When you sew side and sleeve seams by hand, start from the waistband and work up to the underarm.

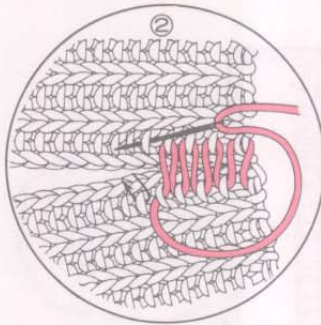

③ When you sew underarm sew as illustrated.



### ● Finishing touch ●

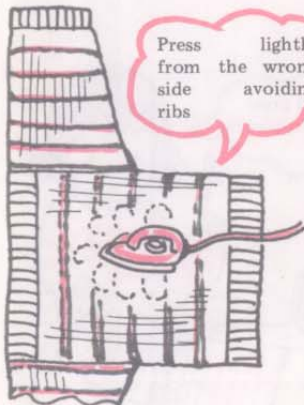

Press lightly from the wrong side avoiding ribs

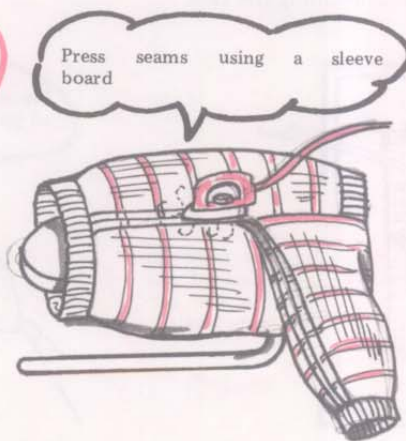

Press seams using a sleeve board



Turn over to the right side and give finishing touch

Don't put it on yet  
You have to wait until it is cool!

# *Step 2*



**Step 2**

# A-LINE SKIRT

I want to make a skirt!



As Pattern has 5 sizes, ES, S, M, L, EL, take the measurements of your body and choose the correct size.

If you measure by yourself it may be hard to get it right. It is better to have someone to measure for you!

Choose the pattern by the hip measurement



If you want more room choose the bigger size

ES size  
S size  
M size  
L size  
EL size

If my measurement happens to be in-between?

**Your Hip (H) measurement**

\_\_\_\_\_ cm

Body measurements chart unit=cm

Decide the size of the pattern referring to your body measurement

Size	Waist	Hip
ES	60	86 - 91
S	65	91 - 96
M	70	96 - 101
L	75	101 - 106
EL	80	106 - 111

Decide how long you want your skirt

## 1: TRACING THE PATTERN ON THE SHEET

## 2: THINGS YOU WILL NEED

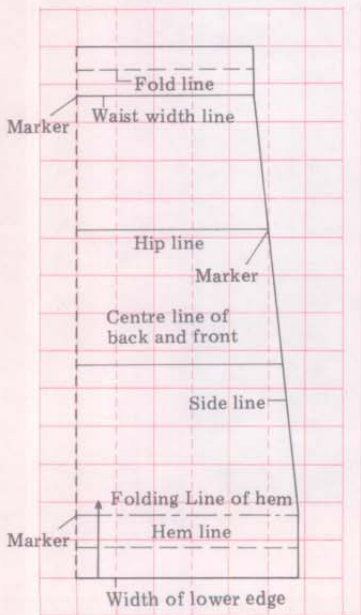

Be sure to place a marker on each part as they are necessary when you sew up



Insert your two fingers into the yarn ball and take the end from inside and pull. Then the yarn will come out smoothly or use a wool winder

Approx Quantity of yarn used (Unit=g)

Size	Main yarn (boucle)
ES	400g
S	400g
M	450g
L	500g
EL	500g

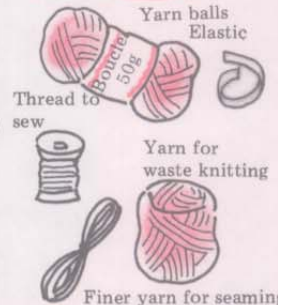

Let's have a piece of elastic for waist measurement +5 cm in length and 2.5 cm width a different colour yarn for waste knitting and a medium fine yarn in similar colour for seaming.

44 Each part of the pattern traced on the sheet.

The front and back are exactly the same



### 3: KNITTING POINTS

- ★ The skirt is in stocking stitch and the wrong side used as the right side.
- ★ Pull elastic through the waistband.
- ★ Remember to place markers.

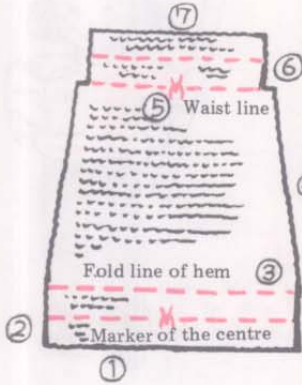

① Cast on — Cast on using 'e' wrap method.

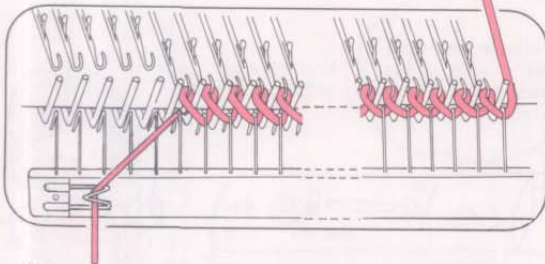

② For under side of hem, knit one whole tension tighter than main garment.

③ Marker — Put markers at the fold line of hem

Centre Marker

Marker of folding line of hem

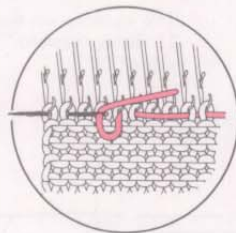
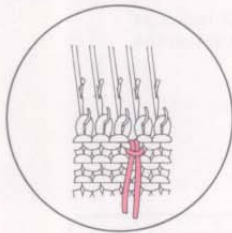

It's so easy!  
I'll make one for my friend



④ Shaping of sides transfer the end stitch to the adjacent inside needle.

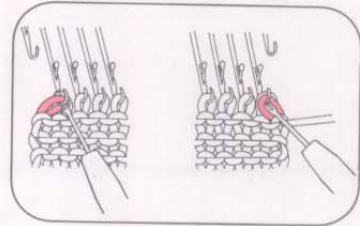

⑤ Marker Put markers at the hem line where waistband is folded, sewn on, and the centre.

⑥ At the waist line decrease 2 stitches for seam allowance when using a sewing machine.

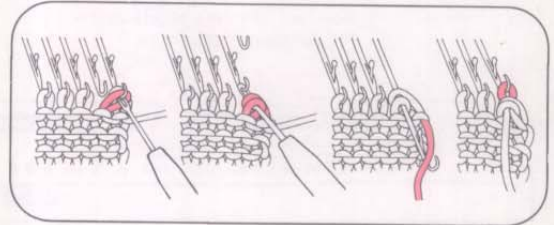

⑦ Tapestry needle

Bind off using a tapestry needle. It's easy.

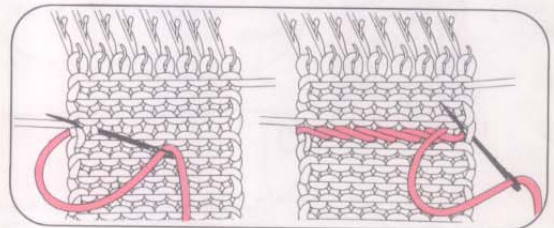



Take the tension gauge carefully since each machine has its own tension .

#### 4: TAKING A TENSION GAUGE

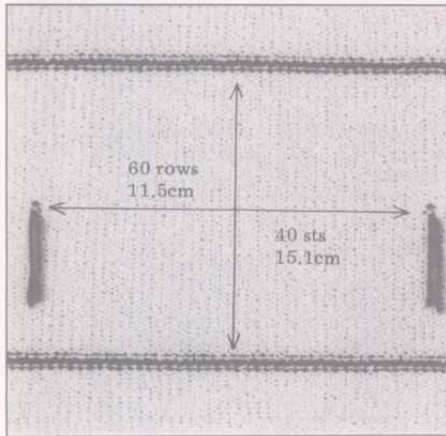

This tension gauge is only for this knitting machine and this yarn

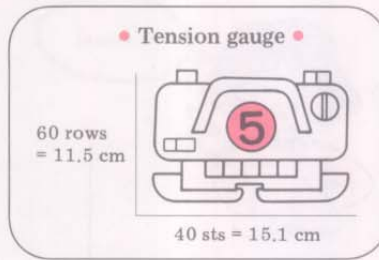

I shall keep a note of the tension gauge



Now set the left regulator to 11, the right regulator to 5

I'll choose the Stitch Scale with the datum line "0" at the left

I've chosen 150-152 Scale No. 16



Roll the sheet and set base line of pattern piece to the Stitch Scale

The number on the Scale indicates 77. Bring forward 77 needles on the side of "0"

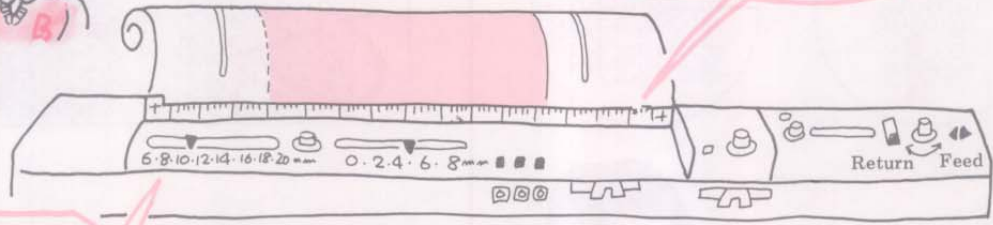

Ensure that the centre line of the pattern pieces matches the centre line of the Stitch Scale.





Cast on using the "e" wrap method

## 5: SKIRT BACK

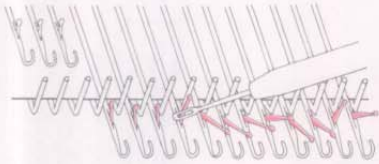

Bring forward the required needles to D position, and open the latches with the transfer tool

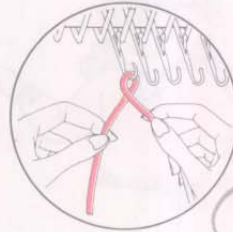

Looping the yarn in the hook loosely, push backward the needles to B position one by one.

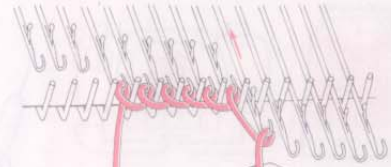

Do not use textured yarns for seaming



Hang the caston comb and hook the end of the yarn to the clip on the caston comb

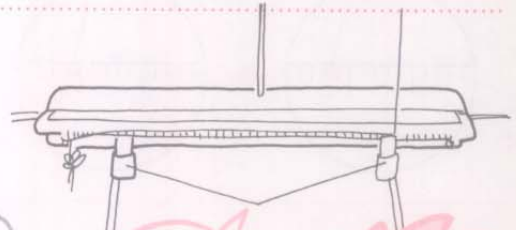

Hang the claw weights on the cast on comb.

Do not hang them directly on the knitting swatch

Work the hem one full tension tighter than the rest of the garment.



Both trippers down



### ● Knit until hem line ●

① Set the Row Counter Tripper and Knit-leader Tripper to working position

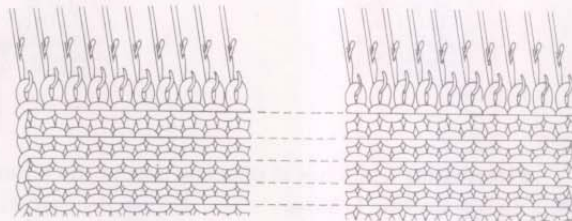

This is where you sew the hem to!

② Place markers on the centre of swatch and position of the hem.

Centre marker

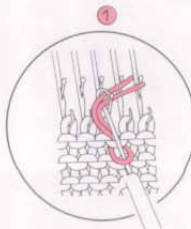

②

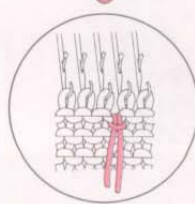

Marker for hemming

①

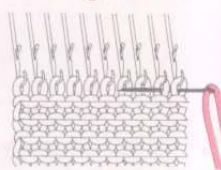

②

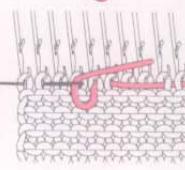

For this marker cut yarn for the width of knitting plus 20 cm and work as illustrated



You can hold the transfer tool either way — see instruction manual

**How to hold the transfer tool**

**● Shape sides by decreases ●**

Knit from hem to waist decreasing at sides.



Be sure to put a marker at hip line

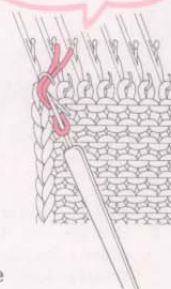

Transfer the end stitch onto the adjacent inside needle in order to decrease a stitch

Before you decrease the knit-leader shows as below.

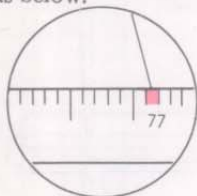

After one stitch has been decreased and before the next stitch is decreased the Knit-leader shows as below.

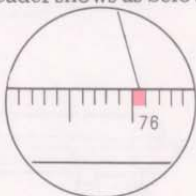

Decrease on the left side.

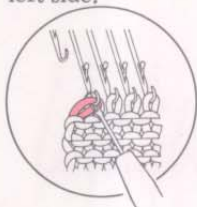

Decrease on the right side.

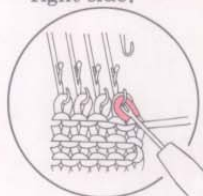

**● Decrease the stitches at the waistline ●**

**● Decreasing 2 stitches at the same side of the K carriage ●**

① Transfer stitch No. 2 to needle No. 1. Move two stitches to needle No. 2. Push the empty needle to A position.

② Place the yarn in the needle hook and push back the needle manually to make a single stitch. Now, one stitch is decreased. Repeat the steps.

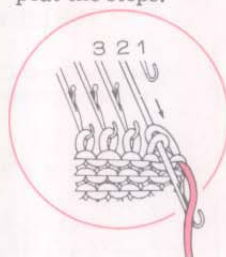
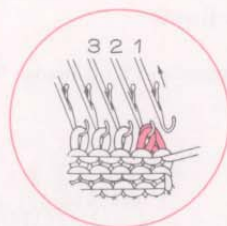

**● Decreasing 2 stitches at opposite side of the K carriage ●**

① Transfer stitch No. 2 to needle No. 1. Move the two stitches to needle No. 2. Push empty needle to A position.

② Pass the end stitch over the needle latch and push back the needle manually to make a single stitch. Now, one stitch is decreased. Repeat the steps.

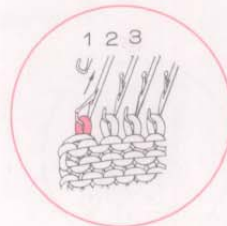
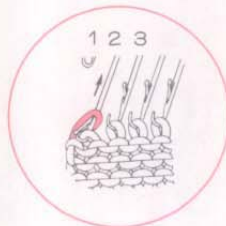
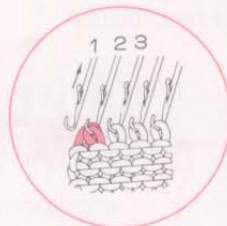
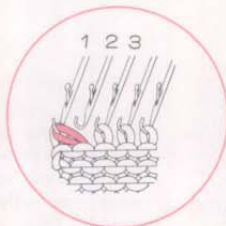



● Waistband ●



Before you knit the waistband place a marker at the centre and run a thread to mark where waistband is turned over to

Marker of centre

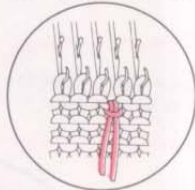

The position where the turned over hem is sewn to.

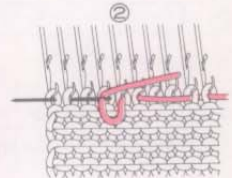
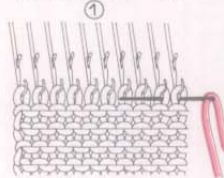

Binding off by using a tapestry needle



Set the Tension Dial at 4 and knit the double the depth of the finished waistband. Knit about 3 rows with waste yarn. Bind off by using a tapestry needle release from machine.



Use a smooth yarn to bind off

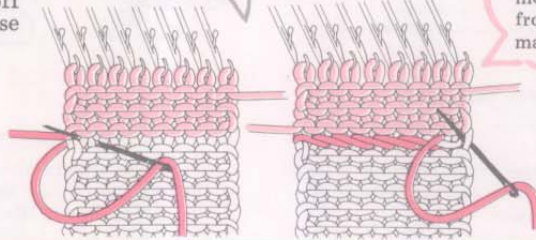

After binding off with a tapestry needle, remove the skirt from the machine

The front is knitted just the same the back



Finished!

It's not finished yet!



7: FINISHING

Leave the markers as they are

● Before you block and press sew in the yarn ends ●

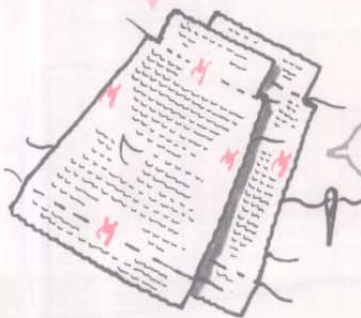

Yarn ends must be finished neatly!

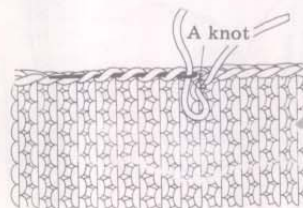

Where a knot appears on the edge divide the ends and thread one towards the top and the other towards the bottom of the garment

● Block and press ●

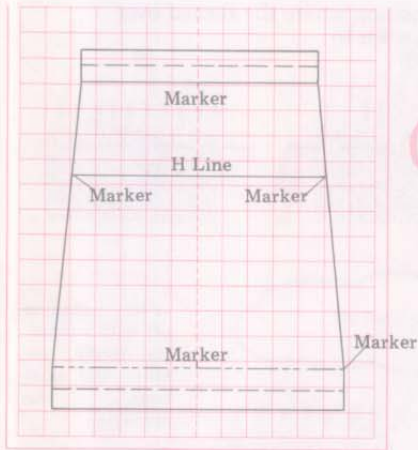

Trace the pattern on paper.

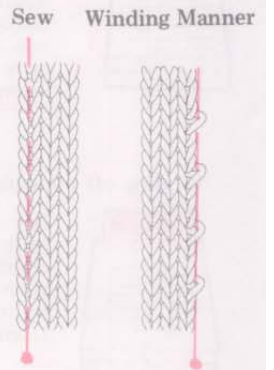
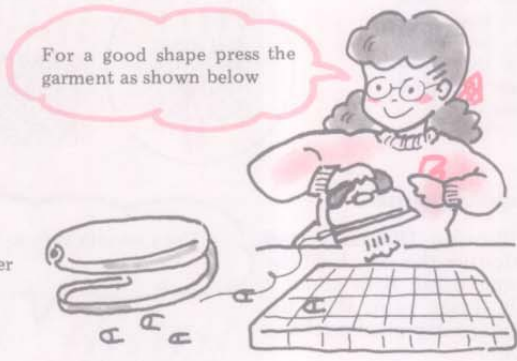

Spread the paper over the pressing table and put pins at the corners and the position of the markers

Put pins around the garment adjusting the outline to the pattern. Then press evenly all over

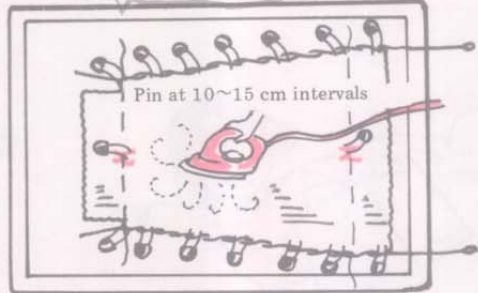
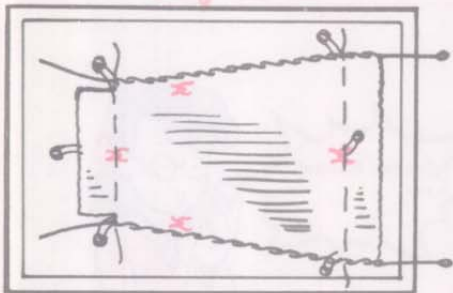

● Use a sewing machine to sew the sides and then press seams ●

① Put the garment pieces, right sides together and pin to hold the two pieces then thread binding wire and baste.

② Using thread, sew both side on the sewing machine.

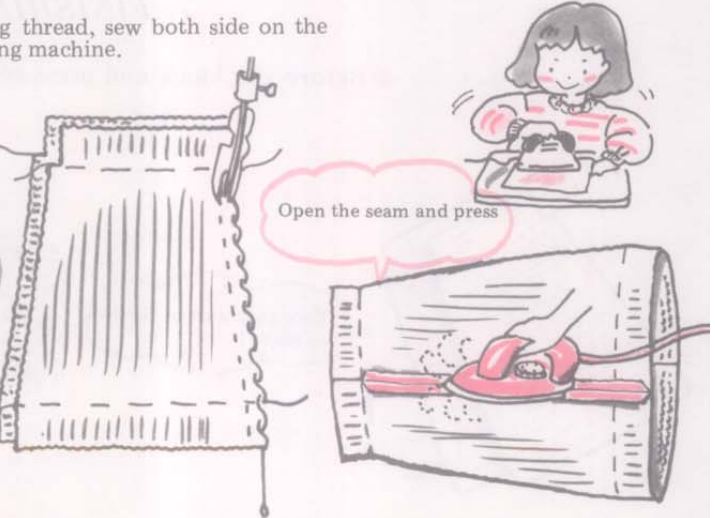
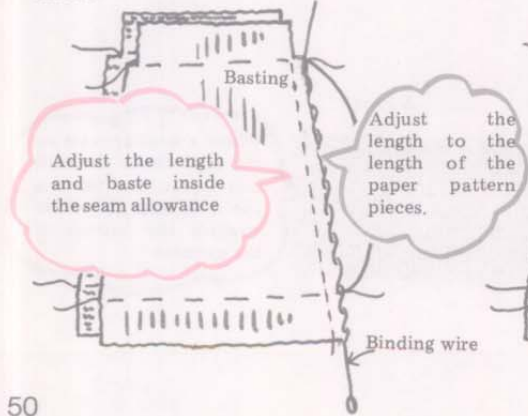



● Fold the hem at waist and hemline and stitch into position ●

- ① Fold the hem adjusting to the marker and press lightly.
- ② Baste into position. Sew the hem of the lower edge and the waist band by slip stitch.

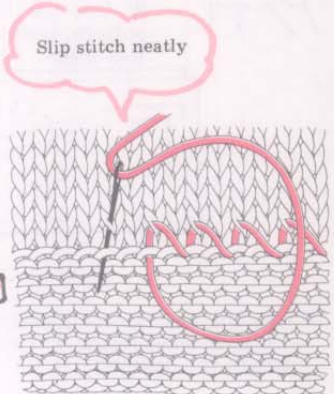

Taking as small an amount of the stitch as possible, slip stitch hem into position do not mark the front of the garment.

● Pull elastic ●

Waist measurement

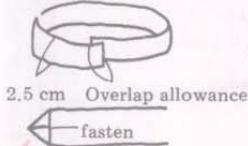

After the waist-band is completed overlap the ends and sew

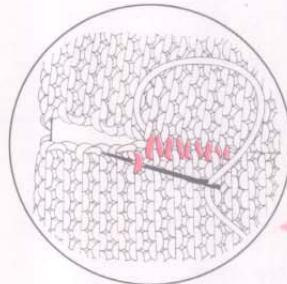

After the elastic has been pulled through close the opening as illustrated

Make a point to make the elastic easier to pull.

● Finishing ●



For acrylic yarn set the iron at SYNTHETIC



Use sleeve board to press seams

Finishing is very important.



Give final press taking care not to pull out of shape



Have the lining for double the length of skirt plus 5 cm (about 130 cm) ready!

You may use a petticoat available in stores as an alternative!



### ● Making the lining ●

- ① Fold the lining double with the right sides facing. Put the pattern paper over it and pin it. Cut the lining along the outline of the pattern, remember to add seam, allowance!

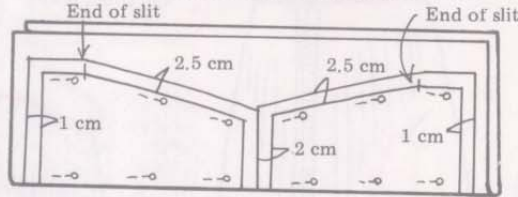

NOTE: The lining is not a stretch fabric as the skirt, so ensure that the waist measurement is a little larger than the hips.

- ② Make the outline of the pattern with a tracing wheel.

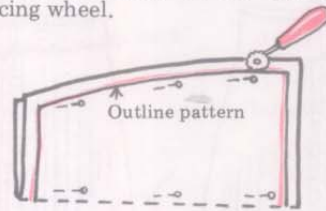

- ③ Place the two pieces together with right sides facing. Pin and baste to the opening.

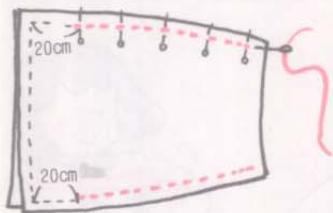

- ④ Using a sewing machine, sew the side seams, 2-3 cm from the edge.

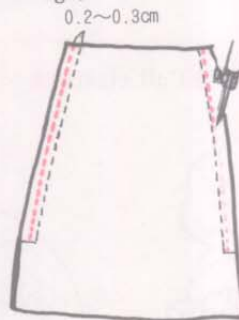

- ⑤ Fold the seams twice and press.

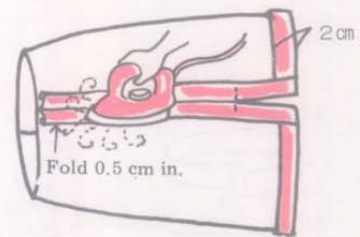

With lower edge, first fold 1 cm press, then 2 cm press

- ⑥ Using a zig-zag stitch neaten seams.

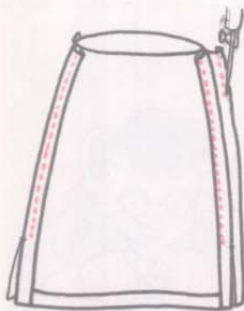

This part of slit is stitched down



Turn up hem

Turning the waist band, First fold 0.5 cm in, press, then fold for elastic

Leave 2 cm open for elastic.

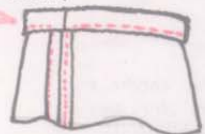

Shall I cut the length a little shorter and attach lace instead...

*Step 3*

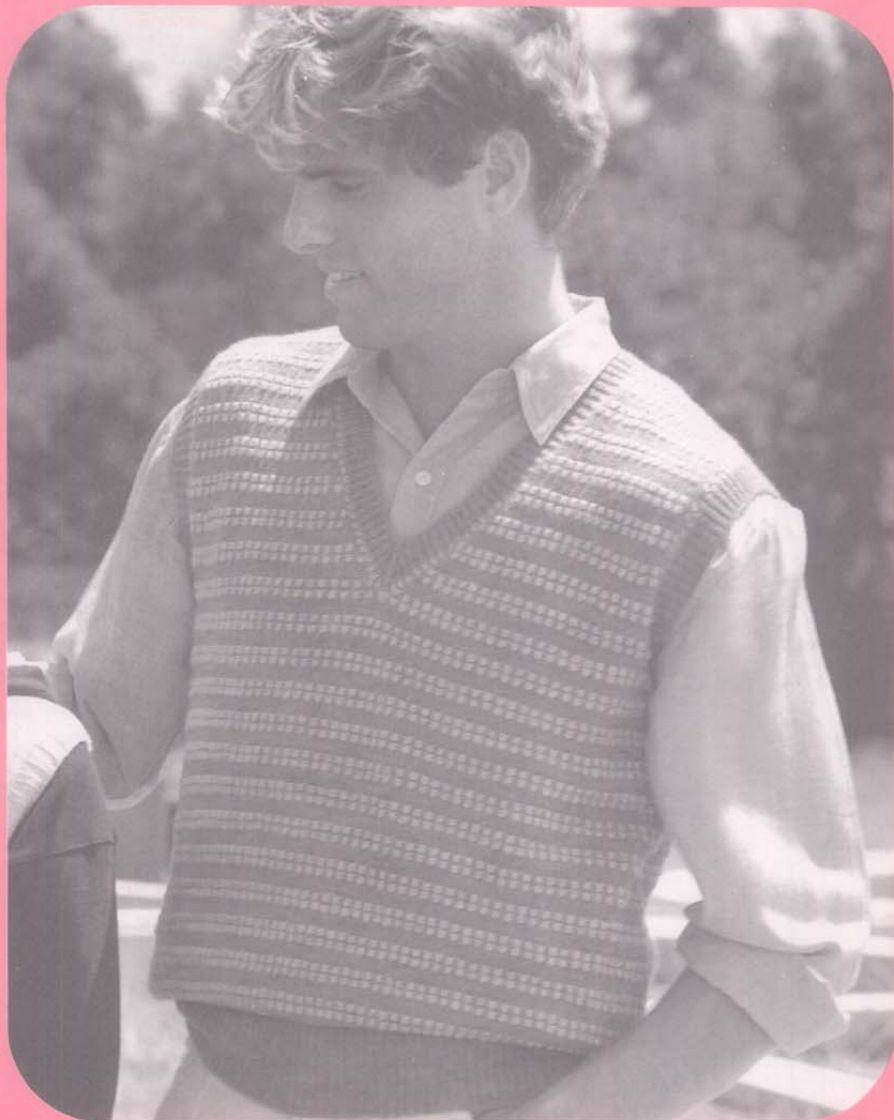

**Step 3**

# MAN'S SLIPOVER



There are 5 sizes. Select the pattern based upon the chest measurement

The person I am going to knit it for has the measurement between M and L ?

If you like a close fit you'd better use a smaller one



I want a slip-over too!

After you have selected the size, trace it on the sheet

Body measurement (Unit cm)

Size	Chest
S	91 ~ 96
M	96 ~ 101
L <sub>1</sub>	101 ~ 106
L <sub>2</sub>	106 ~ 111
L <sub>3</sub>	111 ~ 116

The Measurement you have selected

Chest	Full length at back
cm	cm

## 1: TRACING THE PATTERN ON THE SHEET

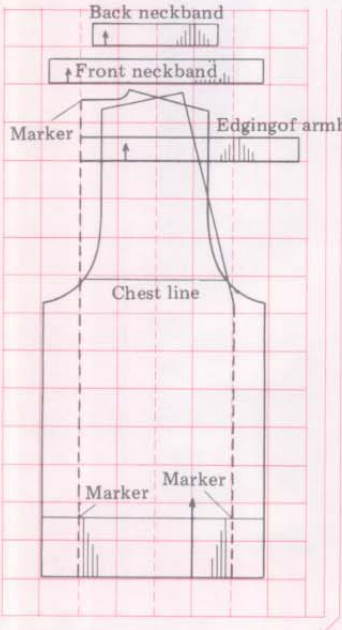

Trace all pattern pieces onto the one sheet.

Each part is traced on the same sheet.

## 2: THINGS YOU WILL NEED



Insert your fingers into the centre of yarn ball and pull the yarn out. The yarn will come out smoothly, or use a wool winder

Approx yarn amounts for man's slipover

Size	Main Colour	Contrast Colour
S	400g	150g
M	450g	150g
L <sub>1</sub>	450g	150g
L <sub>2</sub>	500g	200g
L <sub>3</sub>	500g	200g



In addition to the above have some yarn in contrast colour for waste knitting.

Isn't this exciting ?



### 3: KNITTING POINTS

★ Let's knit the slipover in two colours using tuck stitch

- ① **Waist band**  
Knit in 1 × 1 ribbing

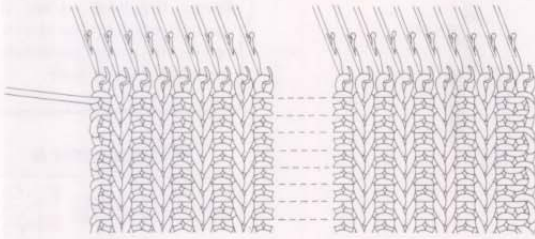

- ⑤ **Front neck opening**  
Shape by decreasing as for armhole.

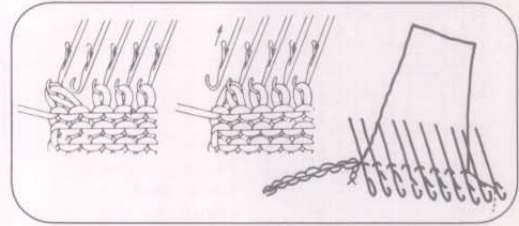

- ② **Armhole** Knit in two color tuck stitch pattern using punch card patterning.

- ③ **Bodice** Knit along the pattern line shaping by decreasing.

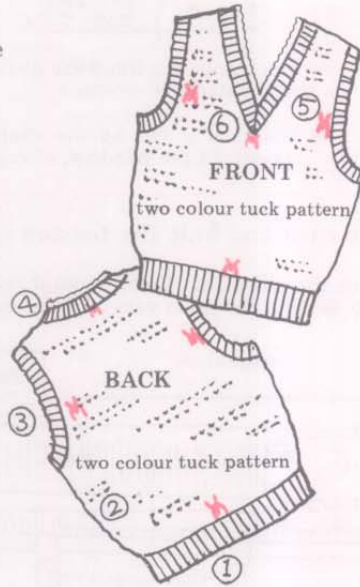
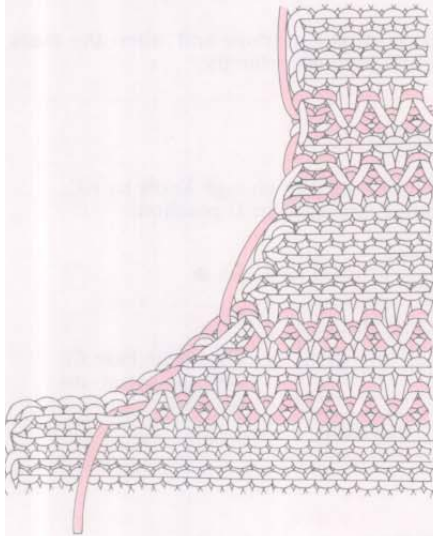

- ⑥ **The point of V-neck**  
A...Knit in 1 × 1 rib.



- B ... Shape V-point by placing 3 sts together on the one needle.

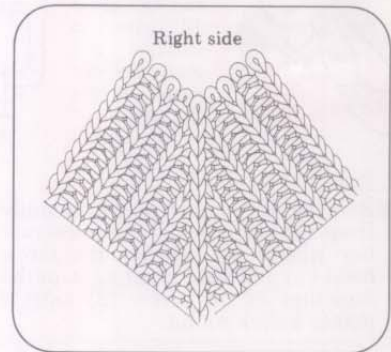

- ④ **Shoulder and the neck opening**  
Shape by decreasing.

Decreasing one stitch at a time

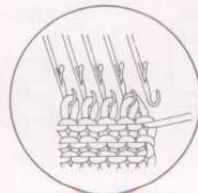
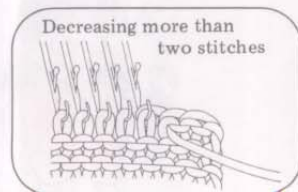



As we've got to make a tension swatch in two colour tuck pattern, let's ready for it.

#### 4: MAKING A TENSION SWATCH

##### ● Make a punch card or a electronic sheet ●

###### ● Punch card ●

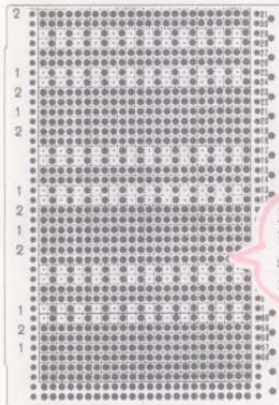

Punch the blank card as shown in the figure

Change the yarn according to the numbers on the left side of the card.

###### ● Electronic sheet ●

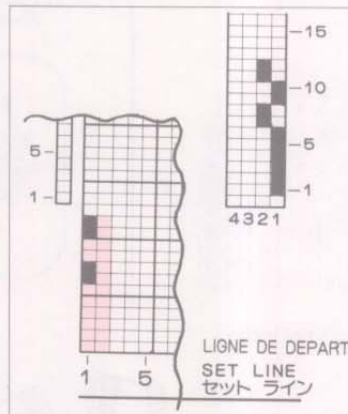

As electronic machines are different from the punch card machines, only a single pattern is required.



As the detailed explanations for how to set the punch card or the sheet is given in your instruction manual, read it well.

###### ● Programme ●

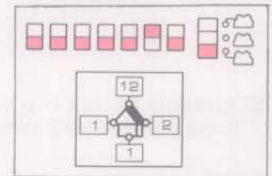

● The card is fed by the operation of the carriage and when the mark appears in the window, change the yarn accordingly.

##### ● Set the card and knit the tension swatch ●

① Set the punch card or the electronic sheet to your machine. Set the change knob to KC, the card lock lever to ● with the main yarn. All the needles are lined in D position.



Set the Tension Dial to 8 and knit about 10 rows in stocking and place the carriage on the left side.

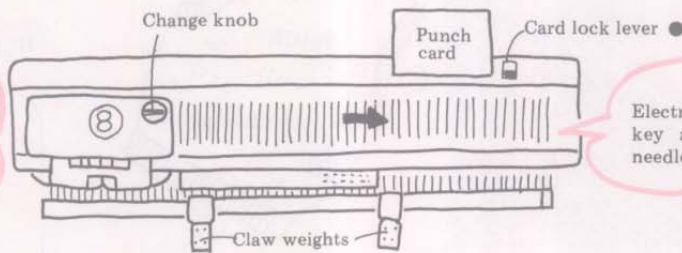

Electronic! Push CF key and select the needles

② Remove the sinker plate assembly from the carriage and place the rubber wheels by pushing the screw head (1) and then pushing it in the direction of the arrow (2) until it makes a click sound.

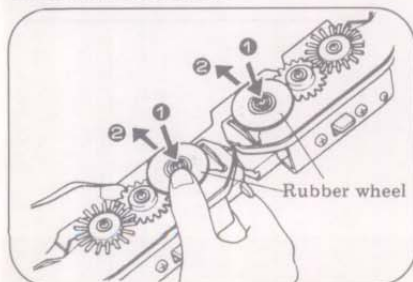

③ Push the both "TUCK" buttons at the same time. Punch card machines set the card lock lever to ▼.

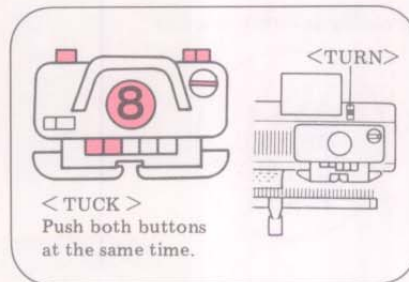

Move the carriage in exactly the same way as for stocking stitch.







Take the tension gauge correctly as every machine and every stitch is different.

● Take a tension gauge and set the Knit-leader ●

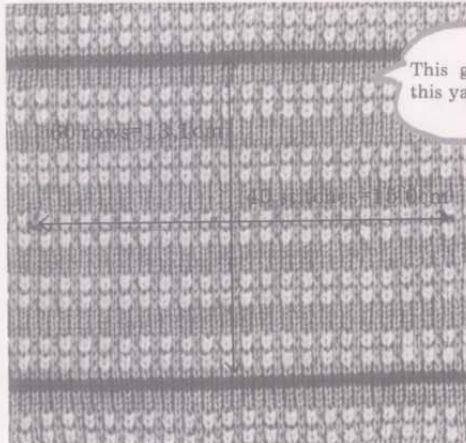

This gauge is only for this yarn and stitch

After you have measured the length write it down your note book



● Example ●

60 rows = 13.1 cm

40 sts = 15.0 cm

Set the left regulator to 13, the right regulator to 1

Stitch Scale

Choose the Stitch Scale for the left datum line

Choose the correct Stitch Scale!

6-8-10-12-14-16-18-20cm 0-2-4-6-8mm 0 0 0

Return Feed

5: HOW TO KNIT THE BACK



Roll the sheet and set the base line of garment piece sheet to the Stitch Scale

The number of the scale indicates 64. Push 64 needles both sides of '0' to B position. Push back to A position alternate needles

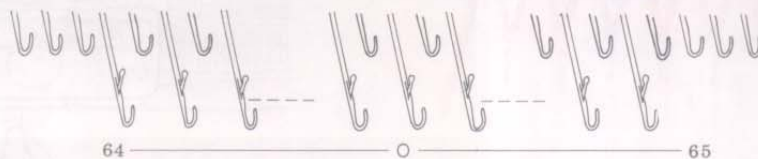
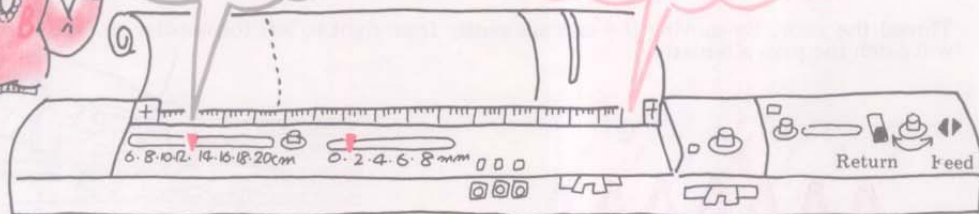



Referring to the Instruction Book for the ribber, set up the machine.

● Knit 1×1 rib with your ribber ●

(1) Set the carriage as below

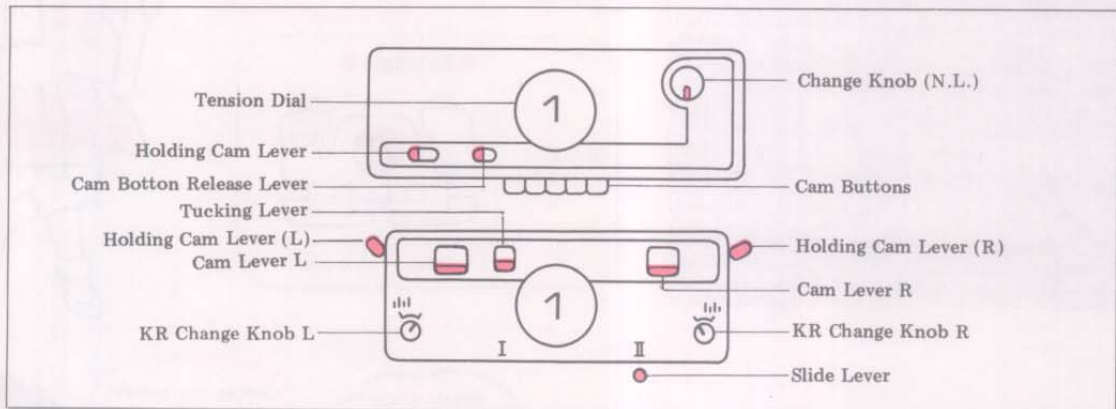

(2) Arrange the needles

Adjust the half pitch lever to P.

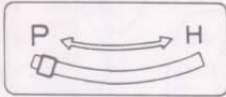

Set the racking indicator on No. 5.

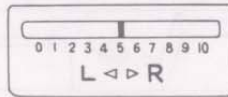

By using the 1×1 needle pusher, arrange the required number of needles on the main bed to B position. Next arrange the needles on the ribber to B position as shown in the figure. (Ensure end needles are on main bed)

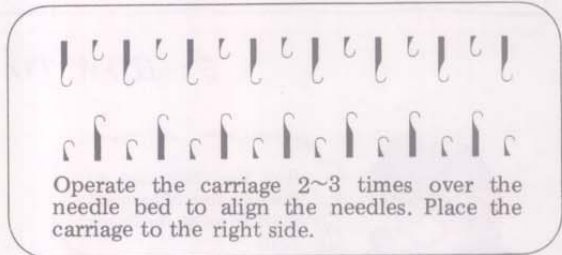

(3) Cast on for 1×1 rib

Thread the yarn. By moving the carriage gently from right to left the needles on each bed will catch the yarn alternately.

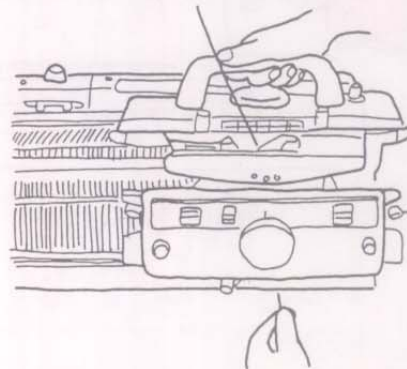
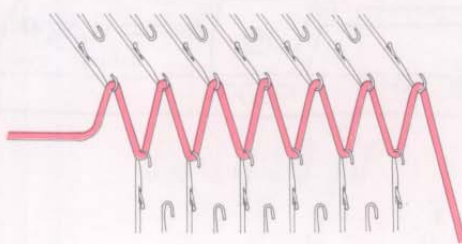

**(4) Hang on the cast on comb**

① Remove the wire from the caston comb

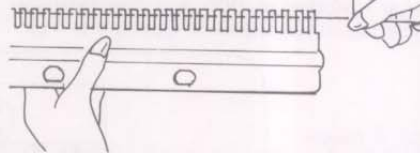

② Pass the teeth of the caston comb each side of the yarn crossing between the needle beds being careful to keep it horizontal. Replace the wire.

Hook the end of yarn in the clip at the end of caston comb.

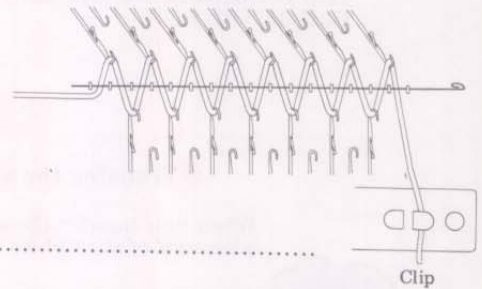
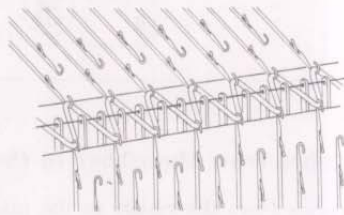
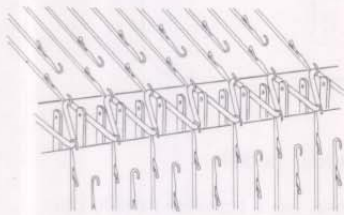

**(5) Hang weights**

Hang weights in balance using standard number of them. (2 big weights per 50 ~ 100 stitches)  
Ensure that the caston comb is kept horizontal.



**(6) Finish the edge by circular knitting**

Set the carriages as shown in the below.

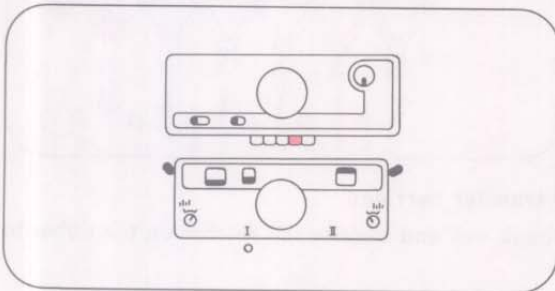

Move the connected carriage from left to right.  
(Needles on the main bed knit)

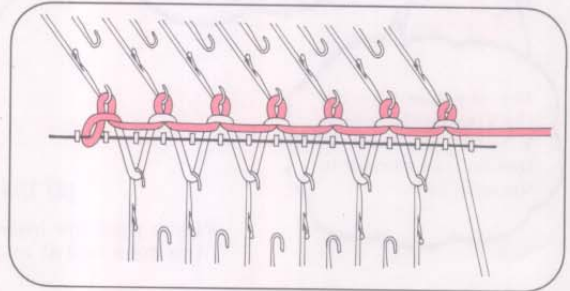

Move the connected carriage from right to left.  
(Needles on the ribbing attachment knit)

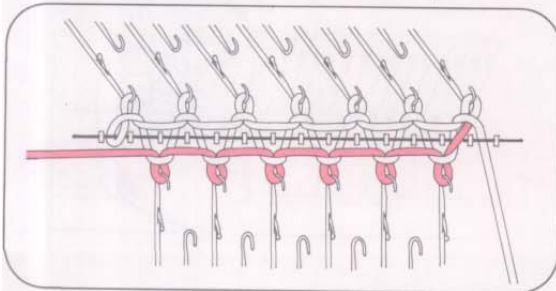

Move the connected carriage from left to right.  
(Needles on the main bed knit)  
The perfect edge is complete.

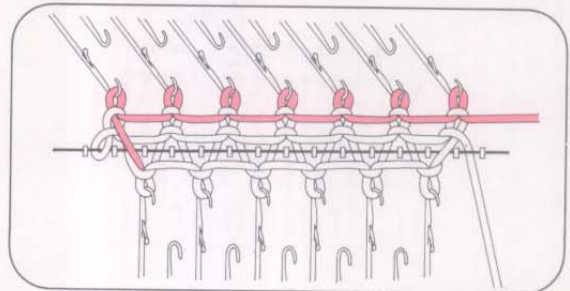

### (7) Knit 1×1 rib

Set the Row Counter at 000 and the carriages as shown below. Move the carriage until the Row Counter is 015.

Move the carriage until it passes over all the working needles before you return it, NEVER STOP THE CARRIAGE IN THE MIDDLE OF THE ROW.

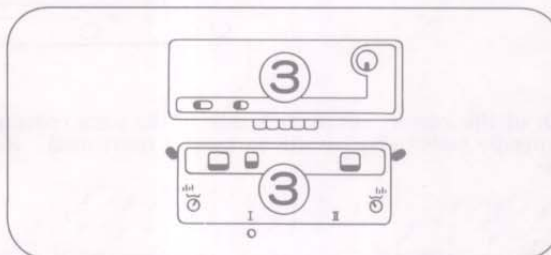

### ● Transfer the stitches from the ribber to the main bed ●

When you transfer the stitches from the ribber to the main bed use a transfer needle (an accessory of the ribber) or the transfer carriage which is sold separately.



The transfer needle is an accessory of the ribber!

#### (1) Using the transfer needle

Take a stitch on the ribber onto the transfer needle and carefully slide it down to the opposite end and slide it into the hook of the empty needle on the main bed as shown below. Push the empty needles on the ribber to A position.

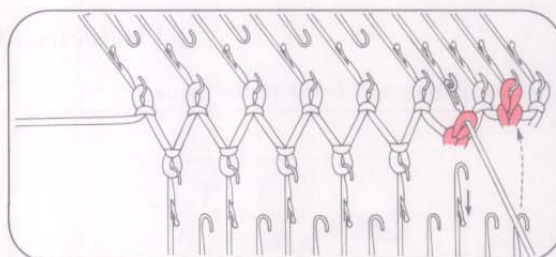

For any one who has the Transfer Carriage, it will be very easy to transfer the stitches to the main bed.

#### (2) Using the transfer carriage

\*Let's read the instruction book well and transfer the stitches on the ribber to the main bed at once.

① Push the needles forward to receive the stitches + a few at the right.

② Set the Change Lever of the Transfer Carriage to the lower position and operate it from right to left slowly by pressing it down gently.

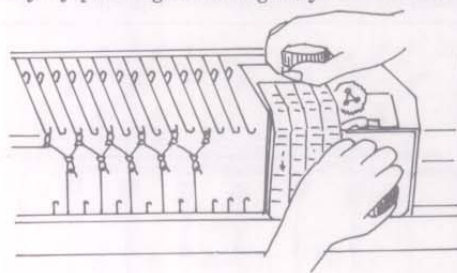
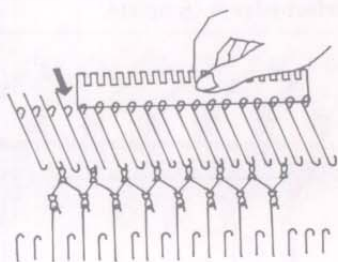

# Coffee Break

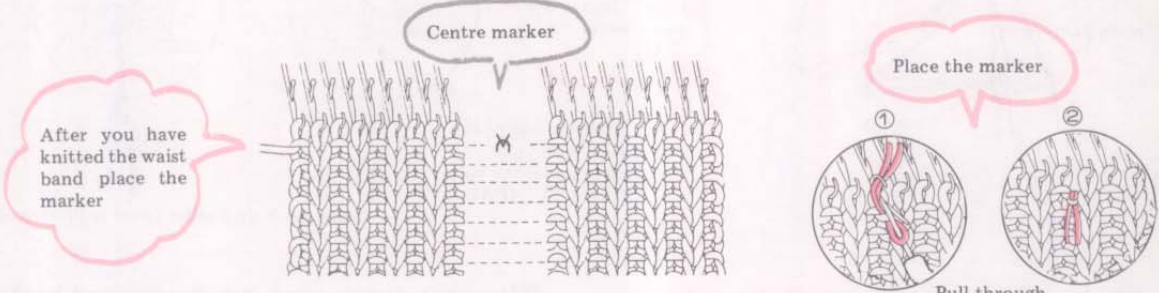

Ensure that you have enough yarn to complete the row and it does not run out in the middle.



The next page is about waste knitting but what is waste knitting?





This is a latchet tool.

Just look here ... This page is ...

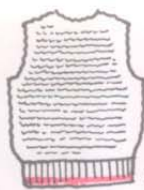

This part is waste knitting, isn't it?

### ● Using a latchet tool ●

① Read the required number of stitches on the stitch scale. Bring forward every other needle to B position as the below figure.



### ● Knit waste knitting and 1 row with caston thread ●



Thread the waste yarn into the yarn feeder "A". (FA).

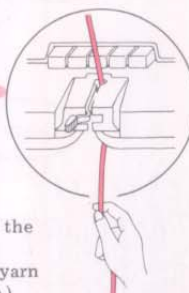

Hold the end of the yarn with your hand under the yarn feeder "A". (FA)

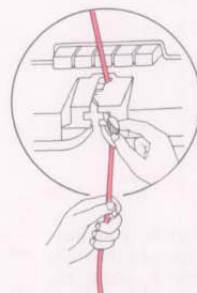

Close the Yarn Feeder Lever as illustrated.

① Knit 1 row to the left.

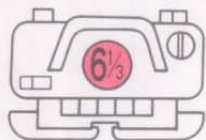

Set the both trippers to non-working position Tension Dial 6 2/3.

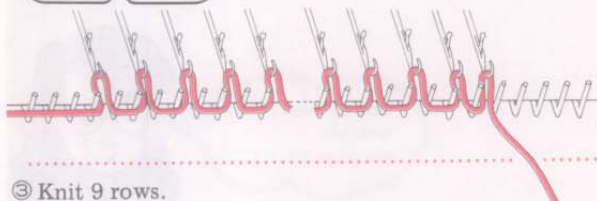

② Hang the caston comb into the yarn and hook the end of yarn under the clip.

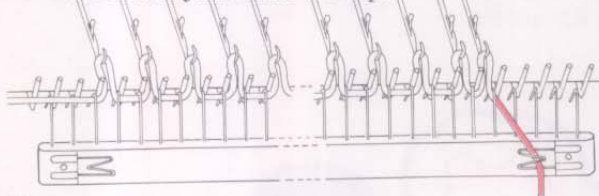

③ Knit 9 rows.

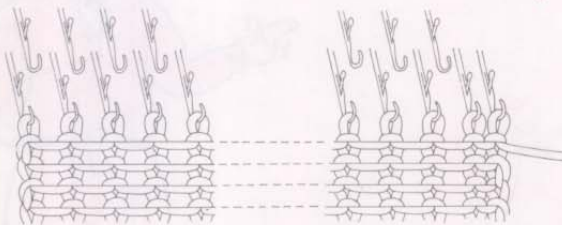

④ Knit 1 row with the special caston thread and remove it from the yarn feeder.

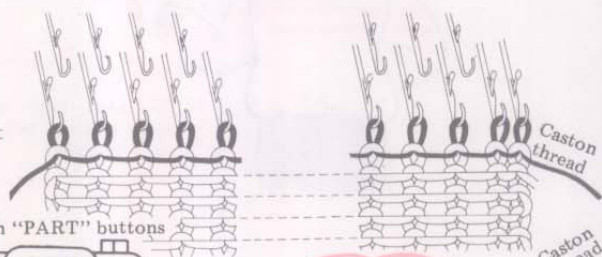

Push the both "PART" buttons



You will find it in the accessory box.





● Caston 1×1 hem and knit the required rows in stocking stitch ●



Thread main yarn. For the finished edge tighten the tension dial

① Knit 3 rows with the main yarn. Pick up the right end sinker loop and hook it onto the right end needle using a transfer tool.

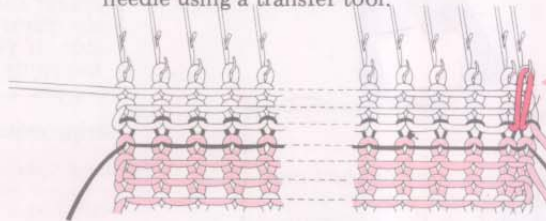

The sinker loop means the yarn between the needles. Look, this is the sinker loop.

② Bring forward the A position needles to B position.

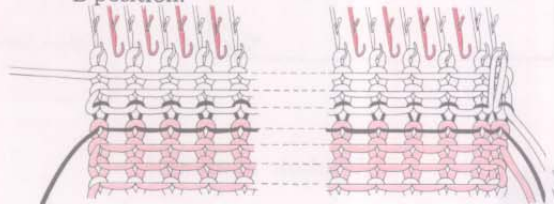

Leave an end of yarn of about 60 cm.

After the edge is finished, set the tension dial for ribbing.

Both trippers down

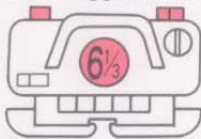

● Change to 1×1 ribbing ●

① Knit the required rows with the main yarn and knit the last two rows with the contrast colour.

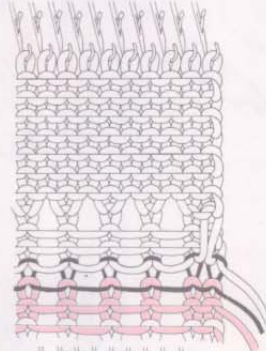

② Drop the 3rd stitch from the right end and unravel the stitches by using the latchet tool.

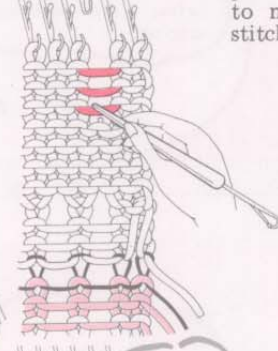

③ Insert the latchet tool under the first sinker loop and catch the 4th sinker loop and pull the latchet tool to make a plain stitch.

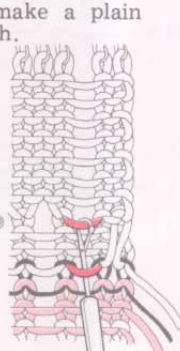

④ Push the latchet tool until the latch is open and previous stitch remains on the stem catch the next loop and pull the latchet tool.



⑤ Repeat until you reach the top, then hook the last stitch onto the hook of the needle.

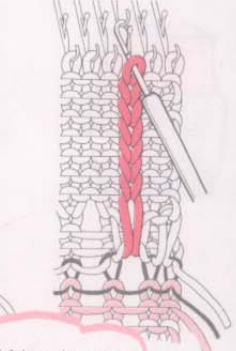

You will soon be able to use the latchet tool quickly.



After the ribbing is complete place the marker at the centre of the knitting.

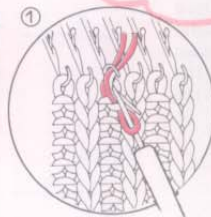

● Knit to armhole shaping changing the yarn accordingly ●



Set the tension dial to 8, and thread main yarn.



Now you have finished the ribbing, and you are going to knit to the underarm, work tuck punch card just as the tension swatch.

Since the explanations here are given for knitting without using a colour changer (KHC 820) for KH, the yarns are changed at the right side. If you use the colour changer the yarns are changed at the left.

Stripe sequence

Contrast Colour 2 rows
Main Yarn 2 rows
Contrast Colour 2 rows
Main Yarn 6 rows

Knit to underarm following the stripe sequence

● Armhole shaping ●



Each time I knit a row I've got to pay attention to the change of the armhole line.

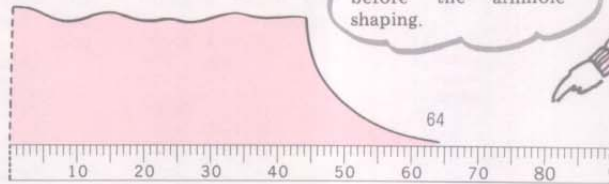

This is what the sheet looks like one row before the armhole shaping.



1 row was knitted and the Knit-Leader sheet moved down so the part of the garment up to the armhole can no longer be seen.

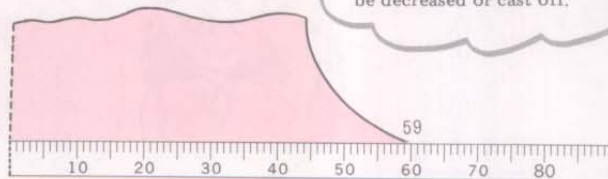

The side has dropped below scale. The part disappeared is to be decreased or cast off.





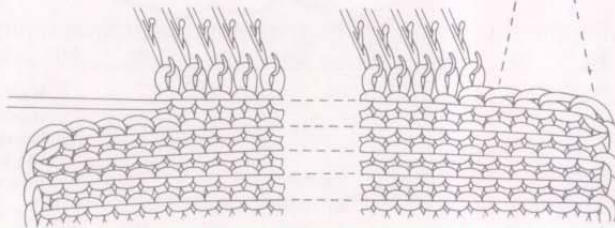
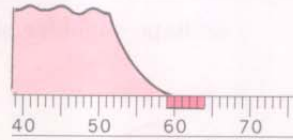

When the needles are selecting for a pattern and you are decreasing you must return the needles to their selected position.

● Decreasing more than 2 stitches (at the side of the carriage) ●

- ① Transfer the 2nd stitch from the end to the end needle.
- ② Move in the two stitches back to the 2nd needle.

- ③ Bring forward the needle to E position. Place the yarn in the needle hook and push back the needle manually to make a single stitch. Repeat these operations until the desired number of stitches are decreased.

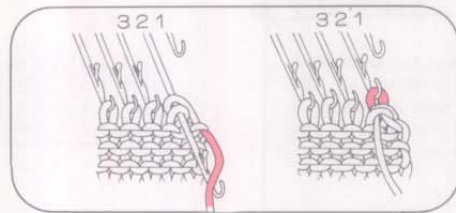
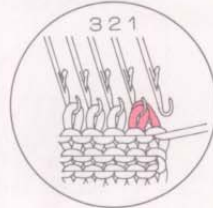
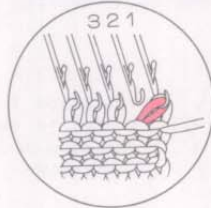

● Decreasing 1 stitch ●

As the Stitch Scale shows a decrease, remember to decrease at both ends of the work —WHEN BOTH SIDES ARE THE SAME SHAPE.

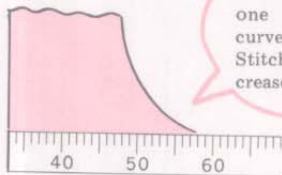

Each time you knit one row read the curve line on the Stitch Scale and decrease as necessary.

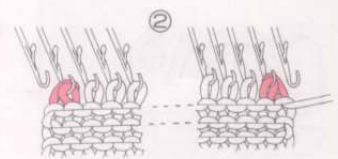
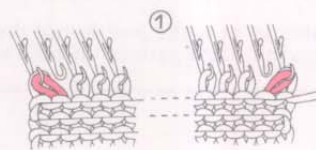

● Armhole shaping completed ●

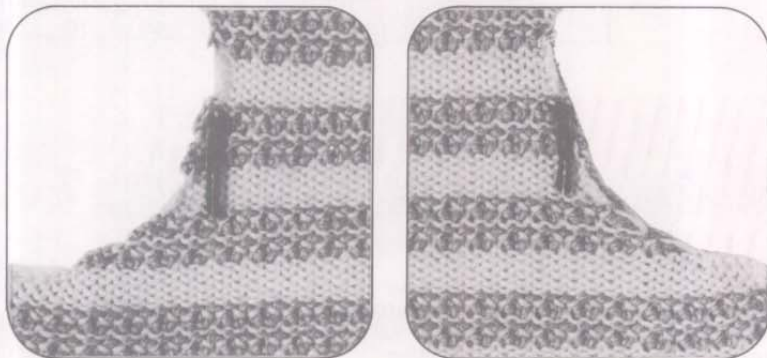

Put the markers at the marked position and continue knitting up the armhole edge

Shoulder decreases and neck edge are worked first at the same side as the carriage.

● Shape shoulder slopes by decreases ●

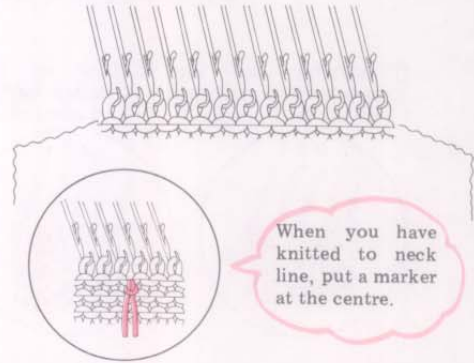
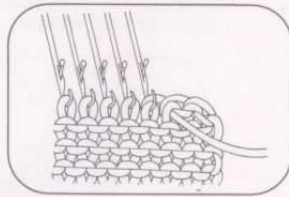
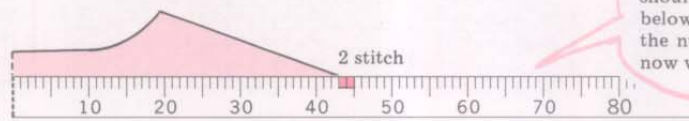
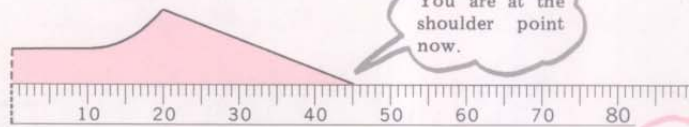

● Shape the neck line and shoulder ●

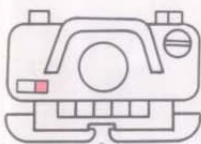

Set the Holding Cam Lever to H.

Keep looking at the card!  
Remember to note the position of the card so you can match up the stitch pattern on both sides of the neck.

Needles for back neck and left side of work are placed in E position.

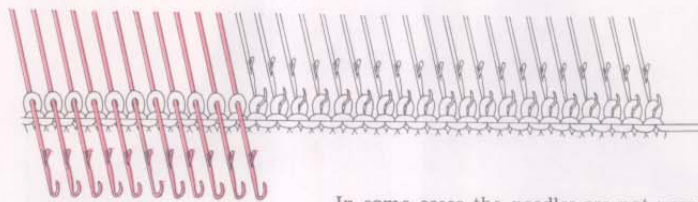
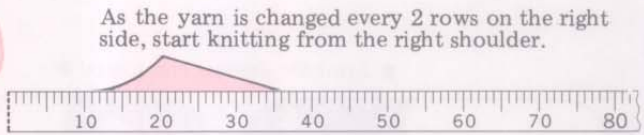

Back neck and left shoulder needles are in holding or E position.

In some cases the needles are not necessarily arranged as shown above as pattern rows will have needles selected into D position.

① Knit 1 row to the left. Decrease the number of stitches not visible from the neck edge.

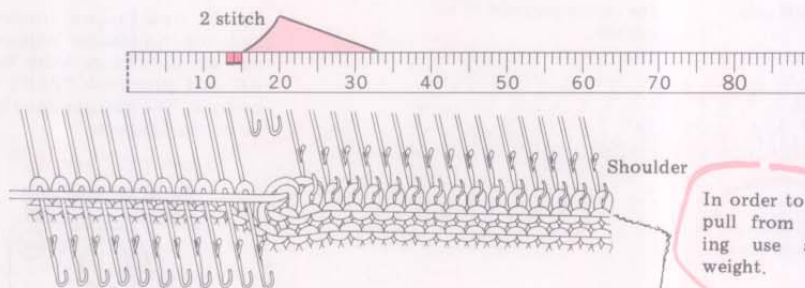

② Knit 1 row and decrease at the shoulder slope.

③ Knit 1 row and decrease at the neck edge.

④ Repeat the above decreasing stitches at the side with the K-carriage. Last stitch is finished by pulling the yarn through.

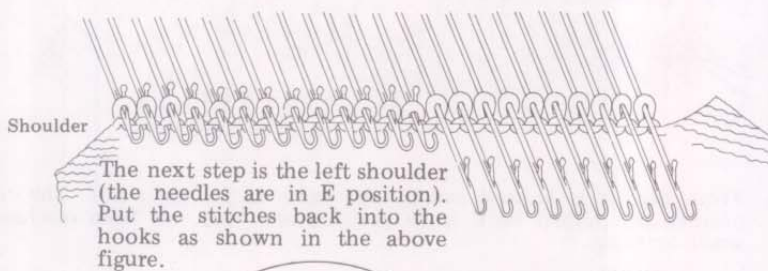
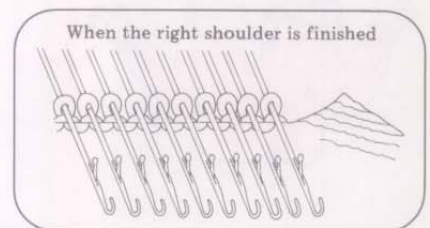
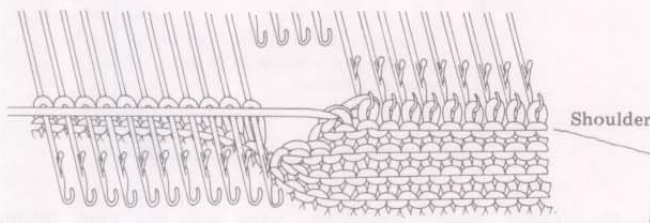
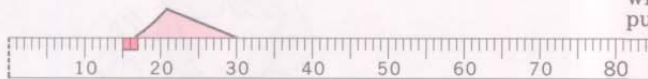

Remember you noted the card position. Now you have to turn the card lock to ●. Adjust the Knit-leader sheet to the beginning of the neck opening. Knit 1 row with PART buttons depressed so the needles select. Place yarn in feeder and knit to match right side.

Knit the opposite shoulder.



Left shoulder

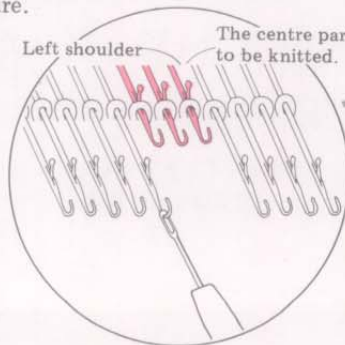

The centre part not to be knitted.

Push back the needles evenly so that the loop from the stitch will go into the hook.

I really like tuck stitch



● USING THE ELECTRONIC MACHINE ●

See the PATTERN KNITTING of "How to shape a round neck line" on page 117 in the instruction manual.

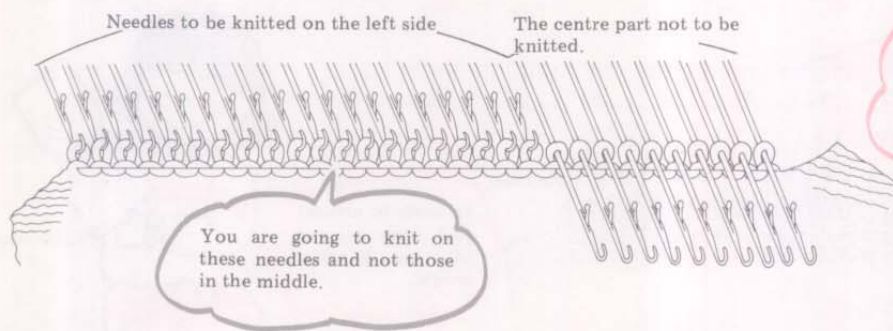

Set the Row Counter tripper and the Knit-leader tripper up, set the change knob to KC, and push both "PART" buttons. The carriage should be on the right side.



Push down the Row Counter tripper and the Knit-leader tripper and push both "TUCK" buttons. Set the card lock lever to ▼

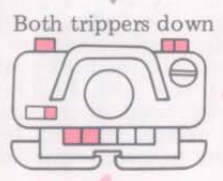

Work the left side to match right side.

Following the Knit-leader sheet. Thread the yarn into the yarn feeder and knit 1 row to the right. Decrease as necessary.

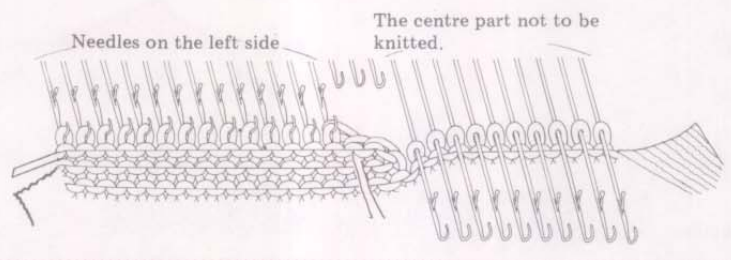

From here it is knitted exactly the same as for right side. The centre needles are pushed back to D position and removed from machine by waste knitting.



## 6: HOW TO KNIT THE FRONT



If any one wants to knit V-neck moving the stitches read this side.

If you are going to use the sewing machine for sewing up at the V-neck, there is no need to add a needle for seam allowance.

### ● WORK THE V-NECK ●

(Three stitches together centre on top)

After you have finished waist band add an empty needle to have an odd number (The middle stitch is used make the point of V-neck opening).

Add an empty needle here

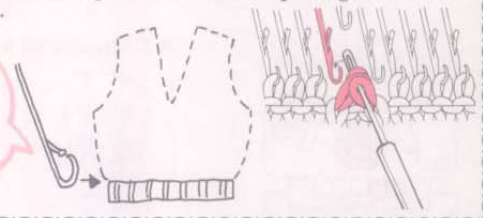

### ● Waste knitting ●

From the neck opening point as left and right sides are knitted separately, take off the left side of work by waste knitting.

When you get to the point where the front divides remember to make a note of the card position.

Set both trippers to non-working position, the holding cam lever to H, and the change knob to N.L. Release the cam buttons or so set to normal.

Change to waste yarn, knit about 10 rows and remove waste yarn from carriage, knit 1 row, waste yarn is released from the needle bed.

Let's place the needles for right neck opening and shoulder in E position and waste knit the left side.



1 row of waste knitting has been knit.

### ● Knit the right side first ●

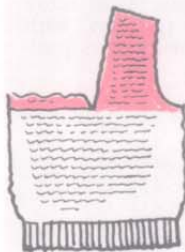

As we have drawn only half a garment pattern piece, work the left side to match the right side but use the same drawing on Knit-leader sheet.

Push back the needles in E position to B position using a transfer tool. You have to do as it is knitted in tuck stitch pattern.

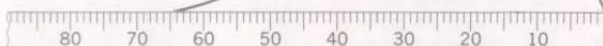
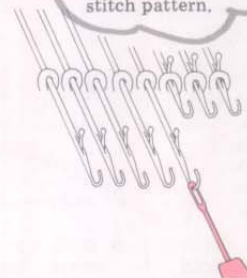

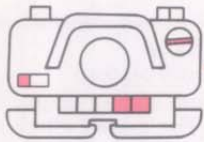

Release Holding Cam and depress both PART buttons.

Leave the card lock lever as it is. If you are using an electronic machine, push the "0" numeral key and CR key for needle selection



Both trippers down



● Decreases of neck opening ●

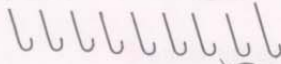
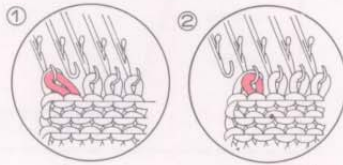

Waste knitting

When the V-point is shaped with three stitches together take the middle stitch off with waste yarn.

Armhole is shaped by decreasing as for the back. Front neck opening is shaped by decreases as illustrated.

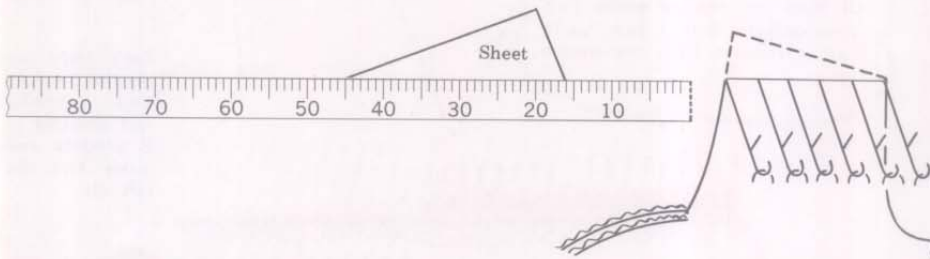

Shoulder slope is shaped by decreases as for the back.

● Knitting the left side ●



Replace stitches from waste knitting back onto their needles

● How to adjust the feeding sheet dial ●

By turning the Dial return the sheet to the position before neck shaping began. Turn more than is needed to start with then adjust to the correct position.



Return the sheet to the mark.

After all the stitches are back, undo the waste knitting and work in the same way as the right side reversing shapings.



Right side which is finished knitting.

When you pick up the stitches fold the waste knitting away from you.

If you are going to use the sewing machine you do not take this stitch for seam allowance.

● Example A - Knitting neckline knitting the neckband ●



To determine the number of stitches for the neckband, place the stitch scale along the neck line.

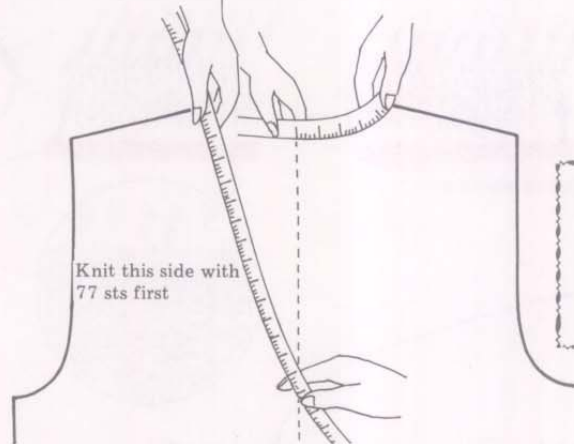

Knit the neckband for left front and right front + back neck opening respectively. (In this case knit one with 77 stitches (38-39 needles) and the other with 121 stitches.)

With the number of stitches as indicated on the Stitch Scale (38-39. needles) cast on as 1 x 1 rib. The neckband is attached with the right side facing so work finished edge of 2 rounds referring to pages 29-30 "Finished edge by 1½ rounds".

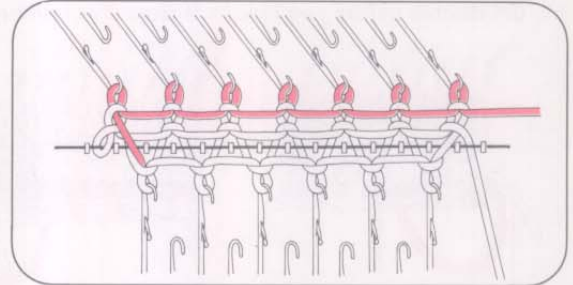
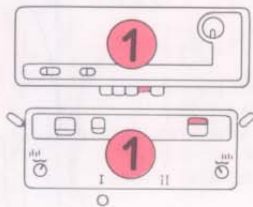

① Set the carriages as shown below and knit 9 rows in 1x1 rib. Knit 2 rows with the contrast colour yarn.

② Transfer the stitches on the ribber (KR) to the main bed (KH) as shown below. Push down the bracket levers of KR and the ribber will drop. Change to the sinker plate assembly of KH. Now you are ready to attach the neckband.

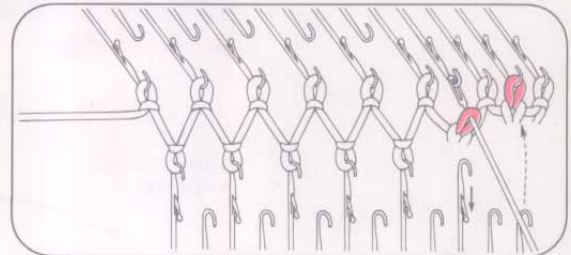
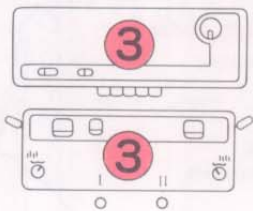

● Attach the neckband ●

① With the wrong side of the front facing you, pick up the stitches from the edge of the neck opening. (The number of stitches is same with the left neckband.)

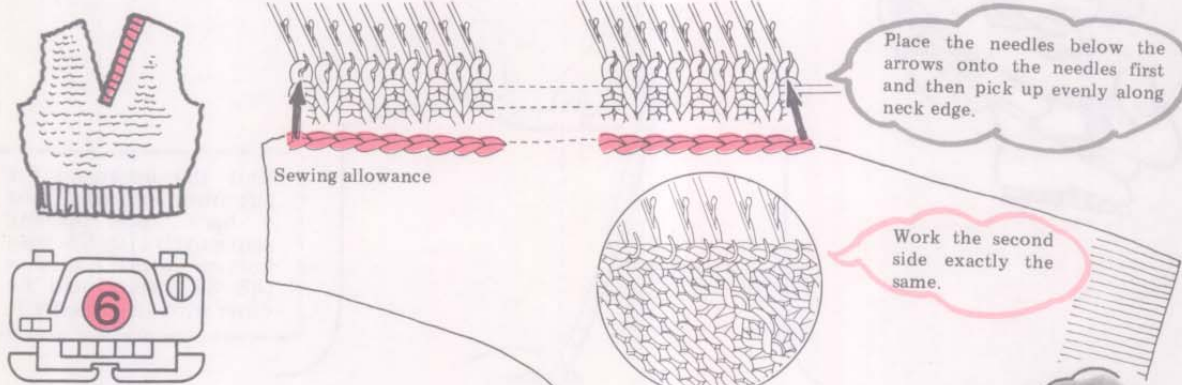

② After the stitches have been picked up, bring forward needles to E position. Attach the sinker plate assembly and knit 1 row from right side. Cut yarn leaving an end of 3 times of the width of the garment. Knit 2-3 rows with the waste yarn and bind off the stitches before you remove it from the machine.

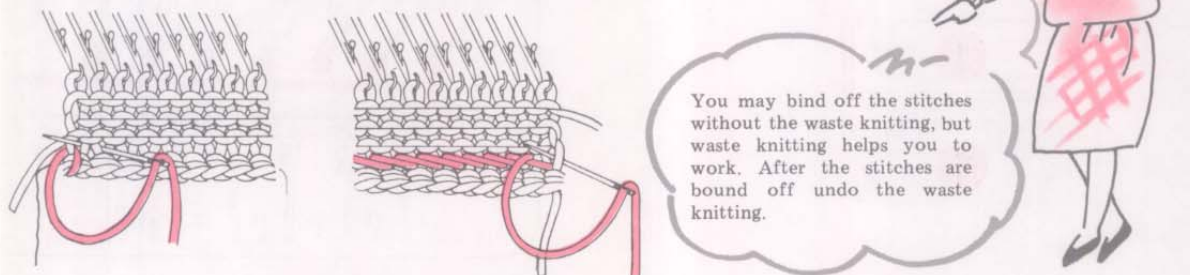

● Knit the neckband for the front and back neck opening and attach it to the bodice ●

① Knit the neckband for the front and back neck opening in 1x1 rib exactly as for left side and attach it to Back and Front as the diagram.

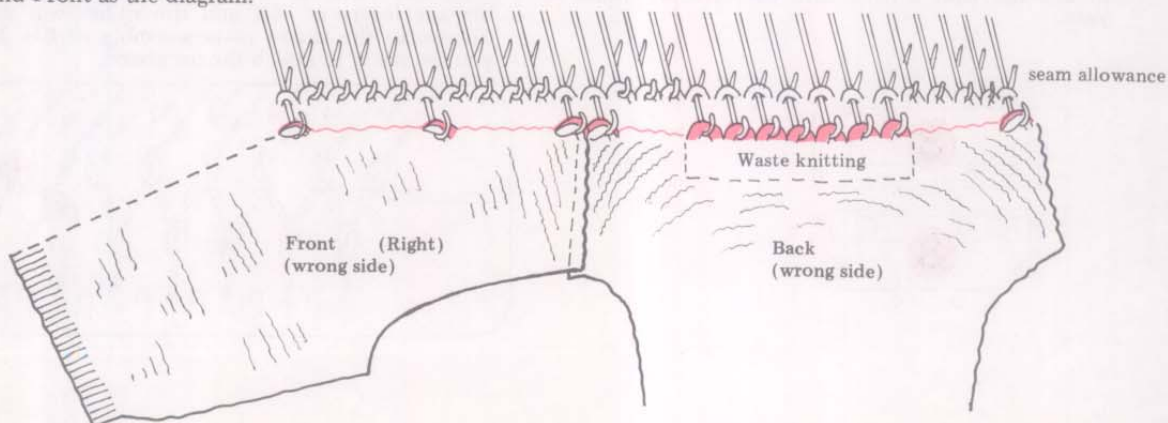





Although moving stitches is tiresome the result is well worth the effort.



The centre stitch at the point of the V is put onto waste yarn.



● Example B- How to knit the neckband with three stitches together ●

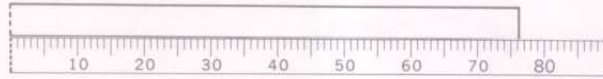

Read the number of stitches on the Stitch Scale and arrange the needles in B position with the centre stitch which was taken off onto waste yarn. Remove the waste yarn. Pick up the stitches evenly on both sides of it.

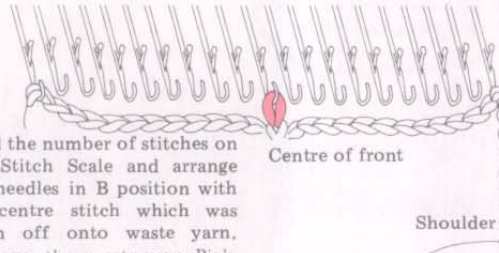

The middle needle with three stitches on is better placed in E position for easier knitting on the next row.

① Knit two rows.

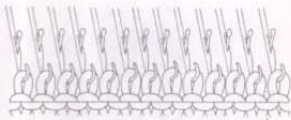

② Reverse the two stitches on both sides of front the needles in B position using the latchet tool.



③ Transfer the plain stitches to the centre needle.



④ Transfer three stitches together onto the adjacent right needle.



⑤ Transfer all needles on the left side to the right.

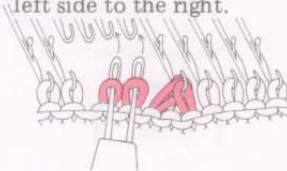

⑥ The stitches have been moved in.



⑦ Knit two rows.

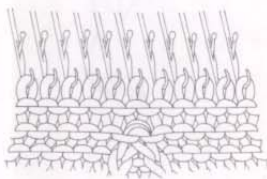

⑧ In this row work three stitches together and move in the stitches.



★ It is possible to reverse the stitches every 4th rows and work fig 4 - 6 every 2nd row, to save time.

When the neckband is the correct length reverse every other stitch along the row. Waste knit. (Refer to Page 37 for waste knitting.)

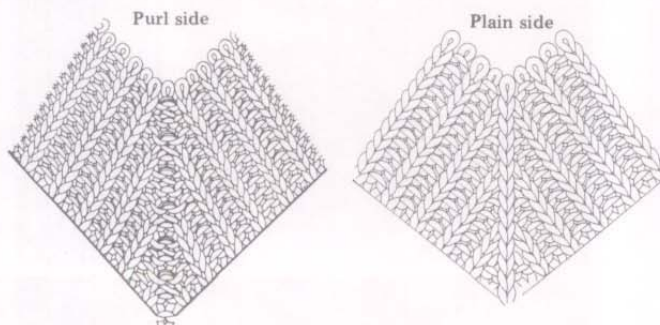

In this diagram the neckband is knitted in 13 rows. However, when you want it narrower or wider, you should make it 9 rows or 17 rows.

Waste knitting



●Waste knit for 1×1 rib●

Push the needles with plain stitch to E position as shown



Push the both "PART" buttons.

Set the Tension Dial to 7 when using 4ply

Knit one row

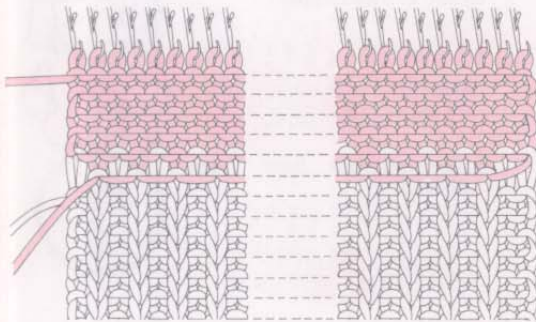
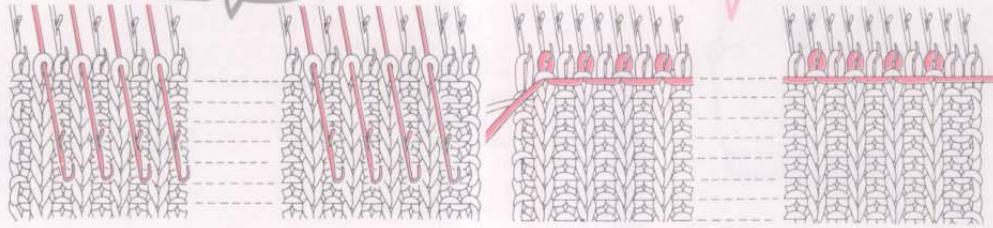

Waste knitting

Release the buttons and knit 10 rows. Remove the work from the machine

Waste knitting



If you waste knit with this, you can finish 1 × 1 rib easily.





### ● Joining shoulders by sewing machine ●

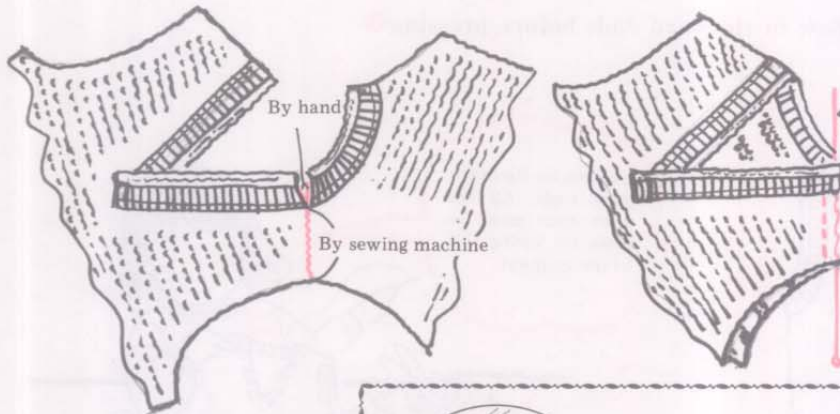

Place the shoulders together with right sides facing and thread the binding wire along the seam edge. Then baste securely into position. Sew 0.5cm from the edge using a sewing machine.

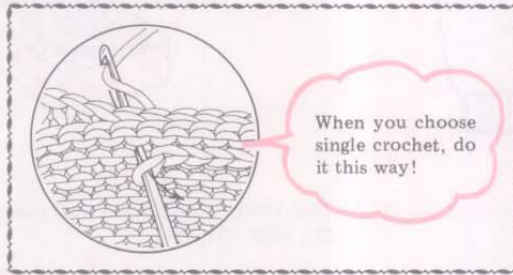

When you choose single crochet, do it this way!



## 7: HOW TO KNIT THE ARMBANDS

Knit 9 rows in the main yarn and 2 rows in the contrast colour. Then transfer the stitches on the ribber to the main bed.

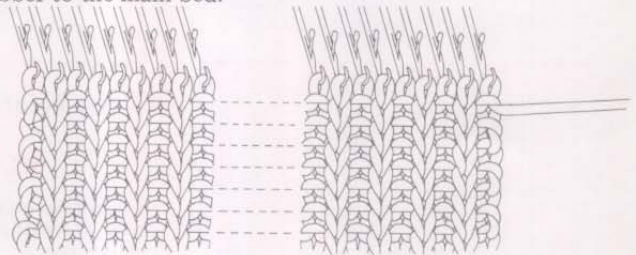

Using the Stitch Scale determine the number of stitches for the armhole and arrange the required needles in B position as for neckband.

As for neckband hang the stitches of armhole on the needles. Push the needles to E position and knit 1 row. Knit 2-3 rows with waste yarn. Bind off the stitches and remove from the machine.

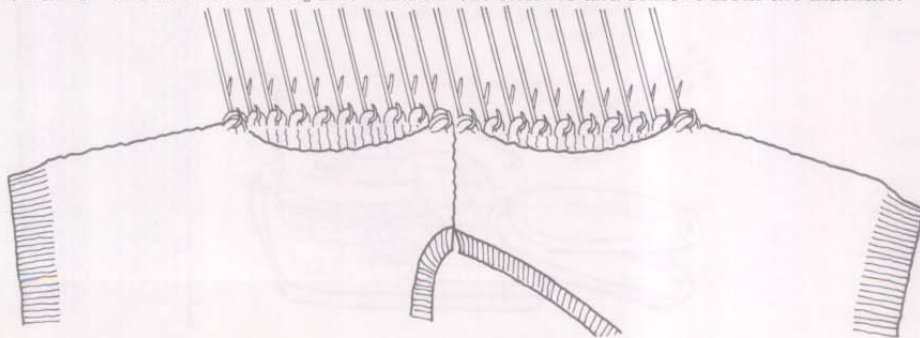

You knit the other side in the same way, don't you.



## 8: FINISHING

● Sew in the yarn ends before pressing ●



I've got to finish the yarn ends. All the yarn ends must be sewn on wrong side of the garment.



As the yarn ends of the ribbed parts are used for sewing leave them.

The knots are divided and passed through the edge stitches.

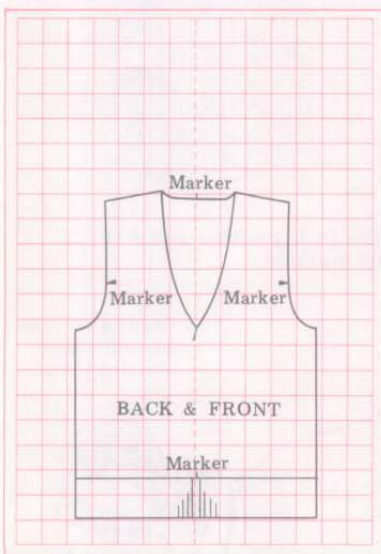
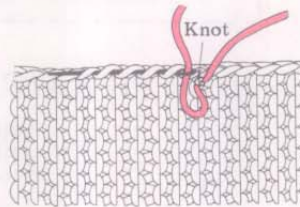
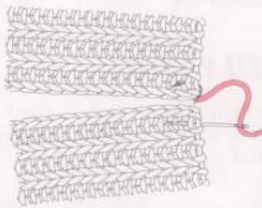

Trace the pattern on the sheet

● Press before finishing ●

● Utencils used ●

In order to give the garment a good shape press it fitting it to the outline of the pattern piece.

Sometimes the edges of a garment stretch, so thread the wires through the edges adjust to correct length and press.

Have an iron, pressing table. Blocking pins, binding wires ready.



Sew Winding manner

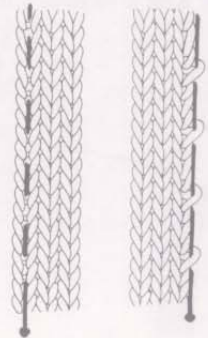

Remember how to finish the stitches of 1x1 rib by hand.



Pin the garment out and block and press.

Pin the garment into shape

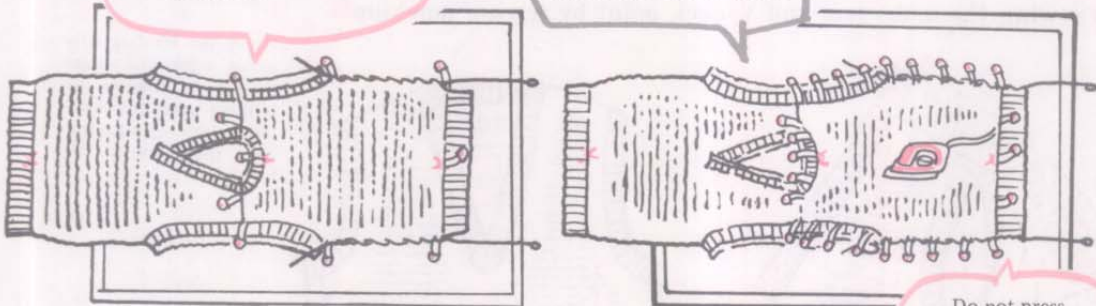

Do not press ribbing

### ▲ Finish 1x1 ribbing by hand ▲

Remember that the neckband and edgings for armholes are released from the machine after waste knitting



① Hold the garment with the right side facing you. Insert the tapestry needle into the 1st and the 2nd stitch from right side.

9 8 7 6 5 4 3 2 1

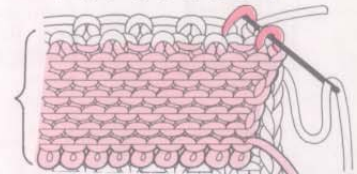

② Pull the tapestry needle through. Insert the needle into the 1st stitch from right side and into the 3rd stitch from the wrong side.

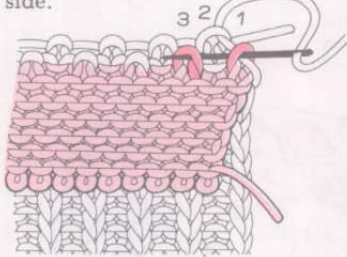

③ Pull the tapestry needle through. Insert the needle into the 2nd stitch from wrong side and into the 4th stitch from the right side.

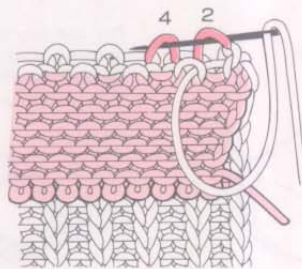

④ Repeat from (2)–(3). At the last stitch insert the needle as shown in the figure. (After all the stitches have been bound off under the waste knitting.)

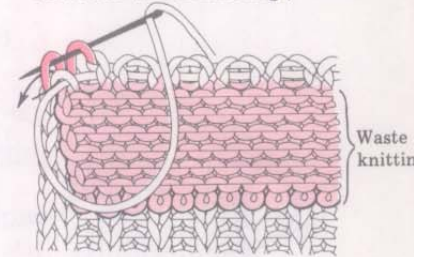

### ● Sew the ribbed part by mattress stitch ●

① With the right sides of the garment facing you, insert the tapestry needle between the 1st and the 2nd stitch as below.

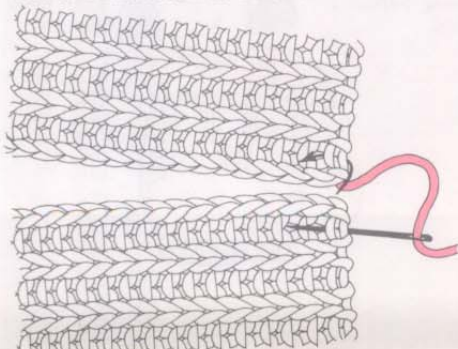

② Each time pick up the sinker loop of 1 stitch inside alternately.

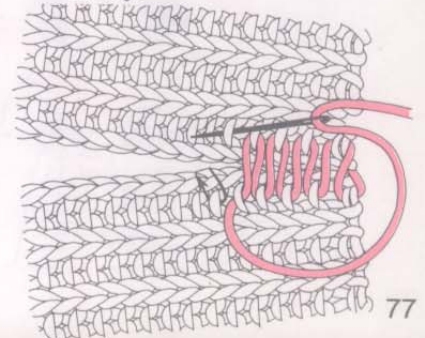

● Sewing the underarm and V-neck point by sewing machine ●

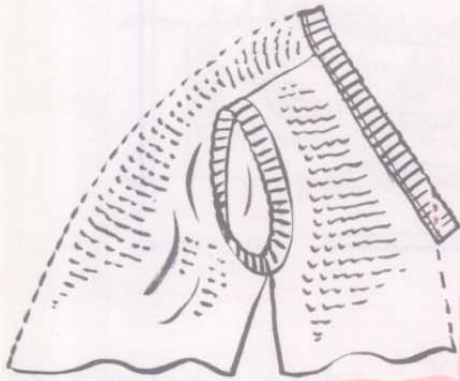

Fold the front bodice at the centre line and firmly baste around the part to be sewn by sewing machine. Then sew it.



Insert the binding wire along edge and baste then sew between the binding wire and basting by sewing machine. You may sew it by hand, too.

Make sure the measurement of the underarm is correct and has not stretched.

binding wire

Sew the waistband ribbing by hand

● Give the finishing touch by steam iron ●

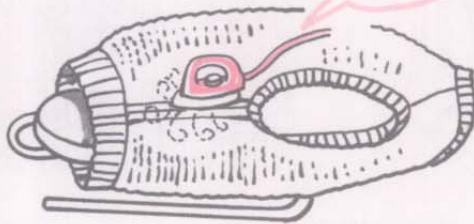

Press seams

Put the slipover on the pressing table and open the sewing allowance of V-point and press.

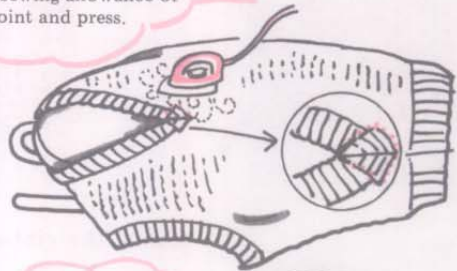

I have to wait until the garment is cool before I wear it.



Little more patience

*Step 4*



**Step 4**

# LADY'S SET IN SLEEVE SWEATER



There are 5 sizes. Select your pattern based upon your bust (B) measurement.



My size is between S and M. What shall I do?



You like lots of room, don't you? Why not choose a bigger size? Even L size!

Select your size based on your body measurements.

**BODY MEASUREMENT**

Size	Bust
ES	81 – 86
S	86 – 91
M	91 – 96
L	96 – 101
EL	101 – 106

**Your measurements**

BUST	BODY LENGTH	SLEEVE LENGTH
cm	cm	cm

Write down the measurement you have taken.

## 1: TRACING THE PATTERNS ON THE SHEET



Trace the pattern you have selected on the sheet.

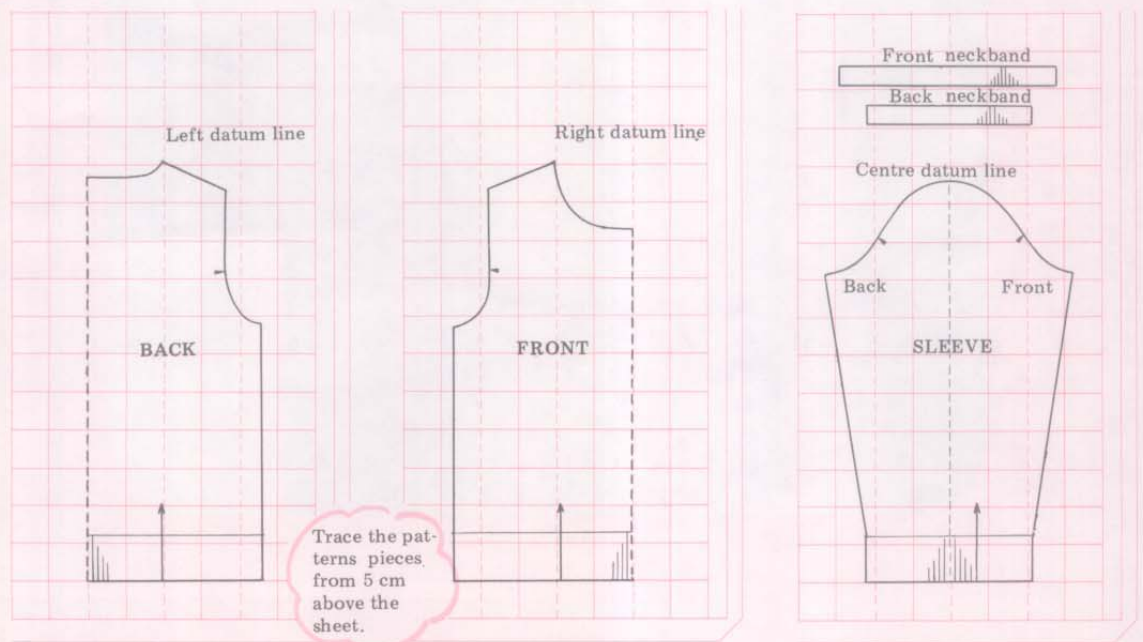



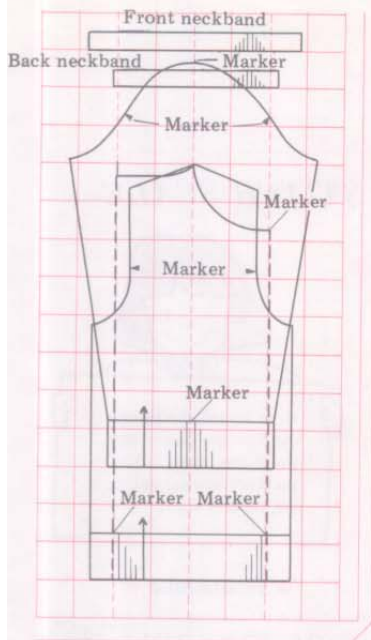

Each part is traced on one sheet.

Remember to place the markers as a guide when sewing up.

## 2: THINGS YOU WILL NEED

Quantity of yarn Unit=g

Size	4ply
ES	400
S	400
M	450
L	500
EL	500

Insert your finger tips into the yarn ball and pull the yarn out from the centre. The yarn will come out smoothly, or use a wool winder.



Remember to have some waste yarn.



## 3: KNITTING POINTS

- ★ Knit the whole garment in fine lace pattern and use the right side.
- ★ Knit the lower edge, cuffs and neckband in 2x2 rib.
- ★ Place a marker at the position marked.

### BACK/FRONT

- ① Waistband ribbing  
Knit in 2x2 rib.

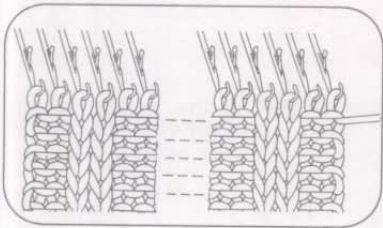

- ② Bodice  
Work in fine-lace to armhole shaping.

- ③ Armhole shaping  
Shape the armhole by decreases.

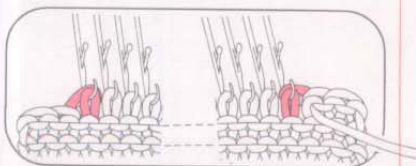

- ④ Shoulder shaping and neck opening  
Shape by decreases.

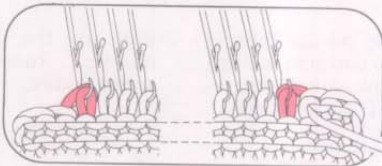

- ⑤ Neckband  
Pick up stitches from the neckline of front and back at one time and knit in 2x2 rib double the finished length.

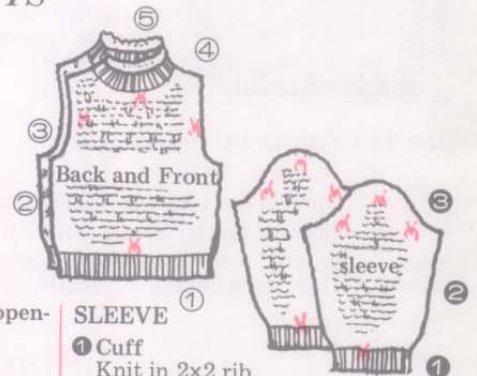

### SLEEVE

- ① Cuff  
Knit in 2x2 rib.

- ② Sleeve  
Knit increasing stitches.

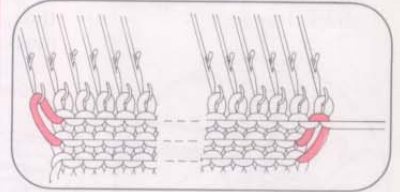

- ③ Sleeve head  
Shape by decreases.

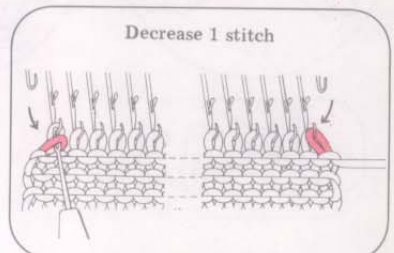

## 4: TAKING THE TENSION AND SETTING THE STITCH SCALE

### ● Make the punch card or the electronic sheet ●

#### ● Punchcard ●

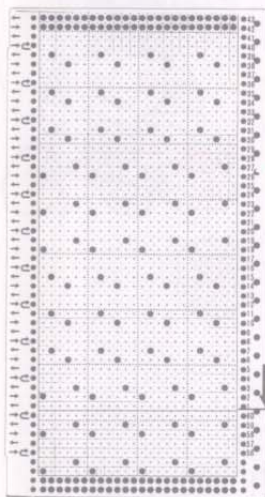

Punch  
this card.

Starting line  
To make a punch card  
see page 154.

#### ● Electronic sheet ●

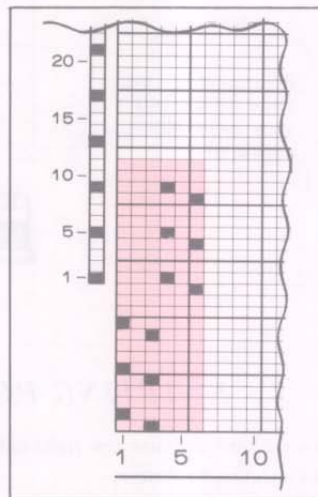

#### ● Programme ●

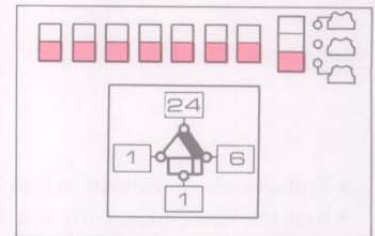

Use the L-carriage and follow the arrows.

- ← ..... Operate the L-carriage from right to left.
- ..... Operate the L-carriage from left to right.
- c ..... Knit 2 rows with the K-carriage.  
Then operate the L-carriage.

The electronic machine is different from the punch card system draw one pattern repeat only using the marking pen (included)

- When the L-carriage is operated the sheet moves down accordingly when ■ appears in the L-window, operate the K-carriage.

### ● L-carriage and the extension rails ●

① Insert the extension rail into the holes with the shaped up side.



② Push the release button of the L-carriage toward the arrow index and remove it from the case.



③ Pull up the L-carriage handle toward the arrow index.



④ Pull the release button toward you and place it on the extension rail.

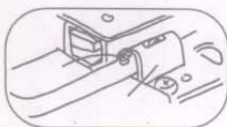

● Insert the card and knit a tension swatch ●

Lock the punch card or the sheet.



Knit 2 rows in stocking stitch, then start to knit in fine-lace pattern. With the electronic machine knit 2 rows then push CF key.



When the yarn is not smooth, let's use the wax supplied.

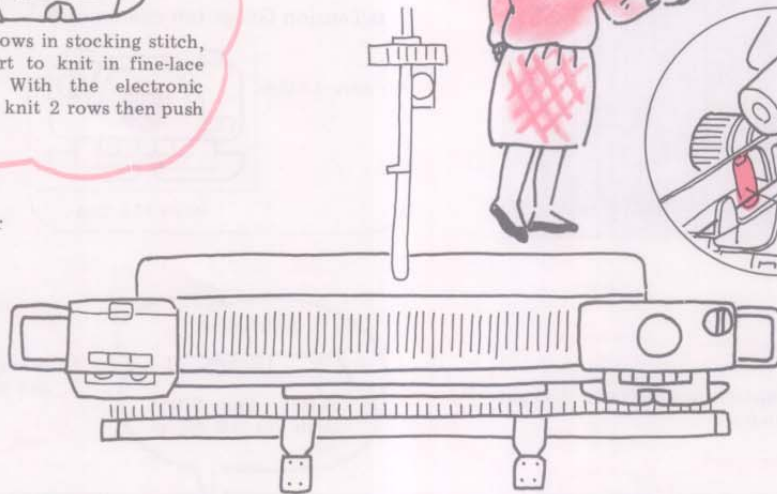
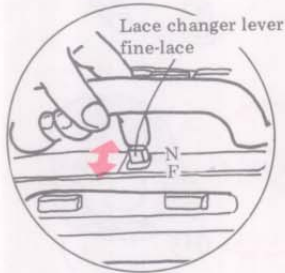

① Set the card lock lever to ● and operate the L-carriage to right to select the needles.

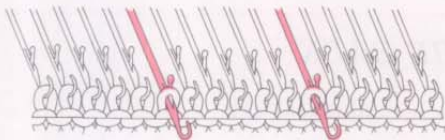

② Set the card lock lever at ▼ and operate the L-carriage to the left. Half the selected stitches are caught in the hook of the next needle on the left, and the next needles are selected.



③ By operating the carriage to the right, half the stitches of the selected needles are caught in the hooks of the needles at right side. Return the L-carriage to the left side.



④ Knit 2 rows with the K-carriage.

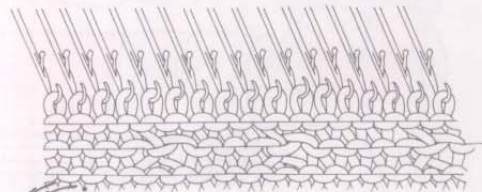

By repeating above operations knit the tension swatch in the same way as stocking stitch.



● Take the tension gauge and set the Stitch Scale ●

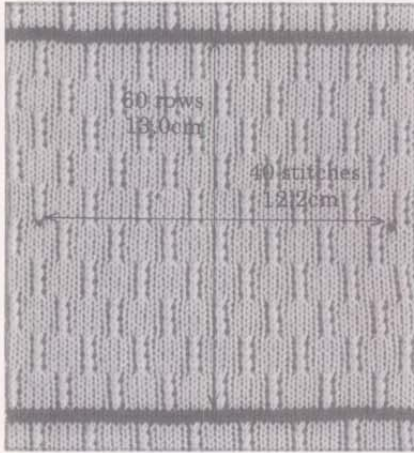

This gauge is only for this yarn and this tension dial.

Be sure to make a note of the length gauge.



● Tension Gauge (an example) ●

60 rows=13.0cm



40 sts.=12.2cm

Set the left regulator to 13 the right one to 0.

Stitch Scale

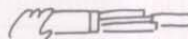

Select the Stitch Scale for left datum line.

That's No. 11, isn't it?

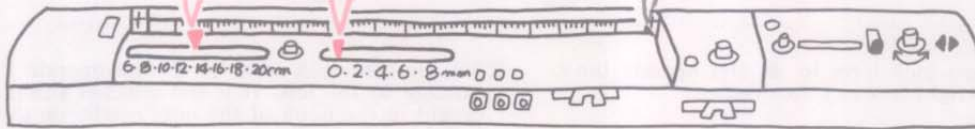

5 : HOW TO KNIT THE BACK

Adjust the number of needles for 2x2 rib. in multiples of 4+2.

By turning the sheet adjust the base line of garment piece to the Stitch Scale line.

Though the Stitch Scale indicates 74 needles, make adjustment to have multiples of 4+2. Then you will have to add 1 more needle on each end and arrange 75 needles on each side of 0 to B position.

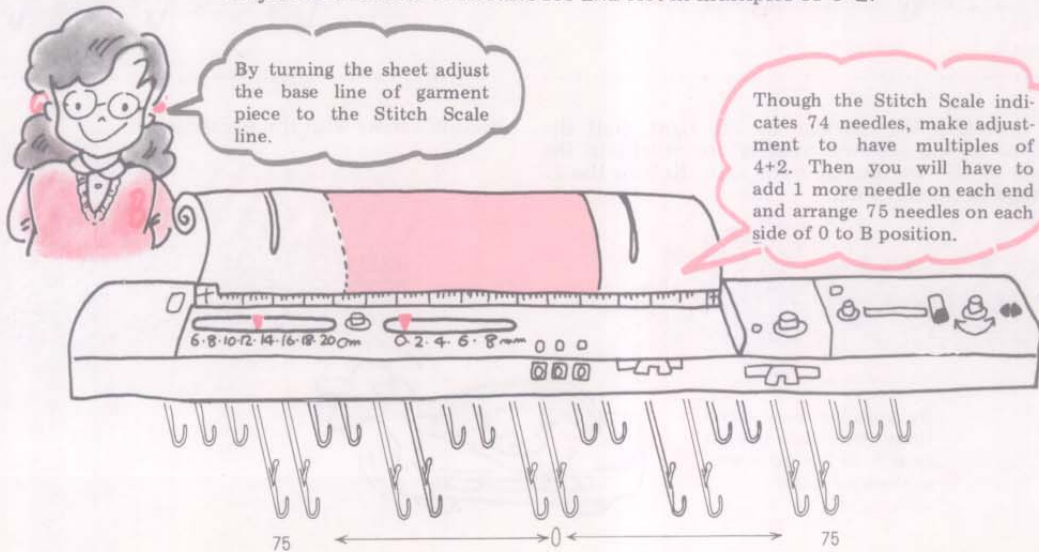



● Knit 2×2 rib ●

Adjust the number of stitches to be in multiples of 4+2 and arrange the needles. Both end needles must be on the main bed. Work finished edge for 2×2 and knit the waistband.



● Finished edge circular knitting ●

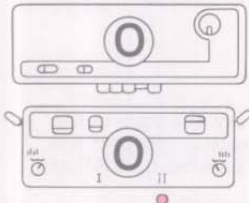

● 2×2 rib ●

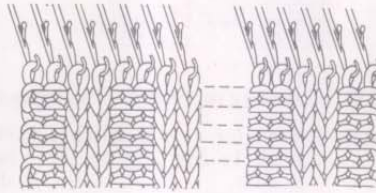
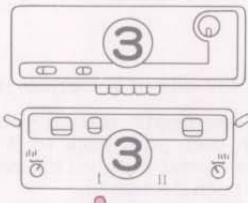

Arrange the needles to have 2 purl stitches on each side referring to the manual

● Knit evenly to armhole shaping ●



Knit in fine lace pattern in the same manner as for the swatch.

● Armhole shaping ●

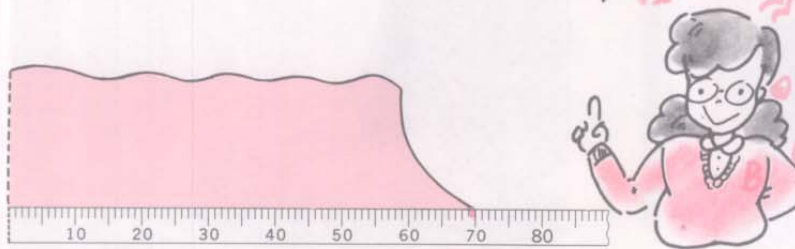
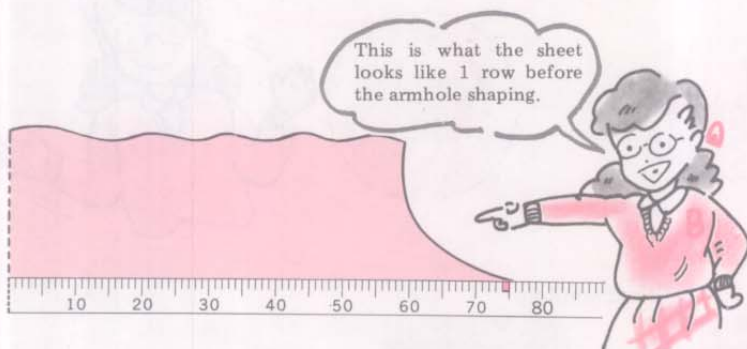

Remember to decrease the stitches after the K-carriage has been operated.

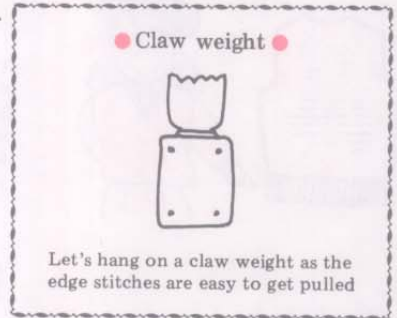
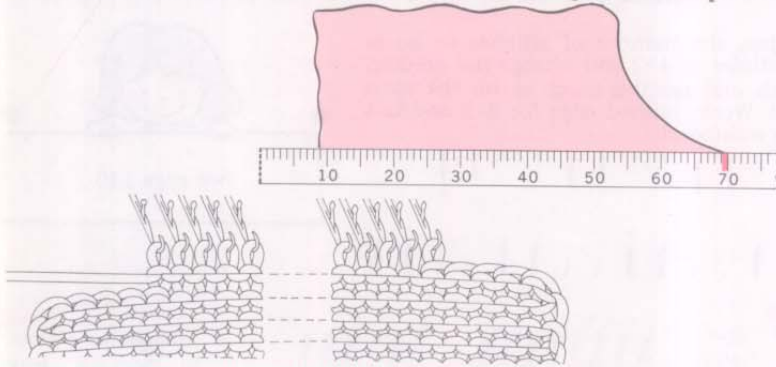

● Decreasing more than 2 stitches (on the side of K-carriage) ●

- ① Transfer the 2nd stitch onto the 1st needle.
- ② Transfer the 2 stitches back to the 2nd empty needle.
- ③ Push the needle toward you, lay the yarn in the hook, then push back to B position. Repeat the above operation until desired number of stitches have been decreased.

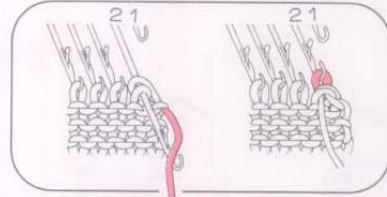

● Decreasing 1 stitch ●

When 1 stitch has dropped below the Scale, decrease 1 stitch on each side.

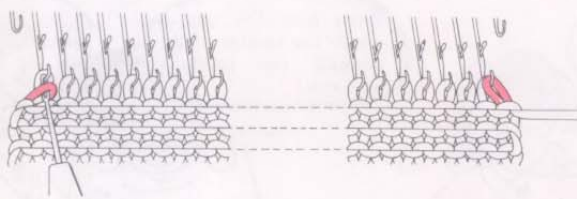

Place a marker at the armholes and continue to knit.

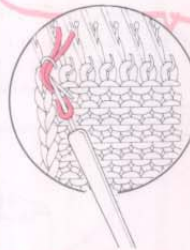

Finished armhole



● Shoulder shaping by decreasing ●

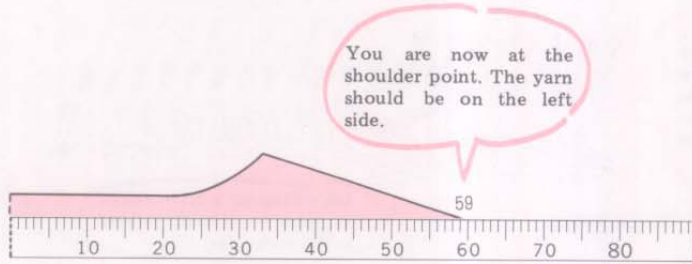

Knit 1 row to the right, decrease the number of stitches not now visible. Operate the L-carriage and knit 1 row to the left. Decrease the stitches on the left side. Repeat the above until the base of back neckline is completed.

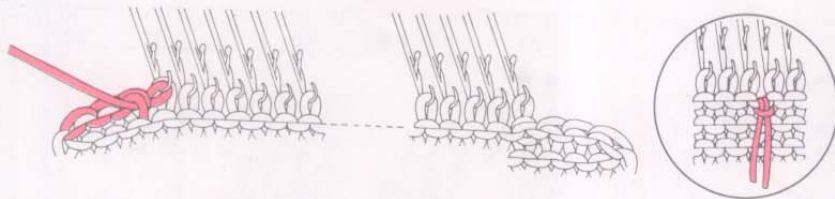

At the base of back neck place a marker at the centre.

● Neckline shaping ●

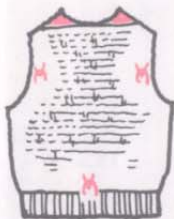

● Watch the card! ●  
The work is divided for the neckline shaping and so the stitches not being knitted are taken back with the special cast-on thread.

① At the opposite side to the carriage, following the Knit-leader take the special caston thread and working from right, pull the needles toward you so the stitches pass over the latch opening it. Place the caston thread into the hook and push the needle back to A position as illustrated.

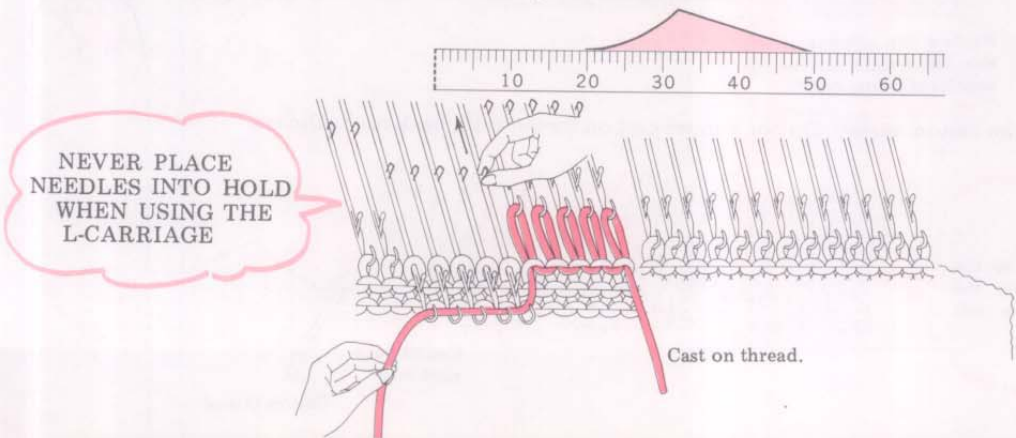

②

Operate the L-carriage, then knit 1 row to the left with the K-carriage. Decrease stitches at the neck edge

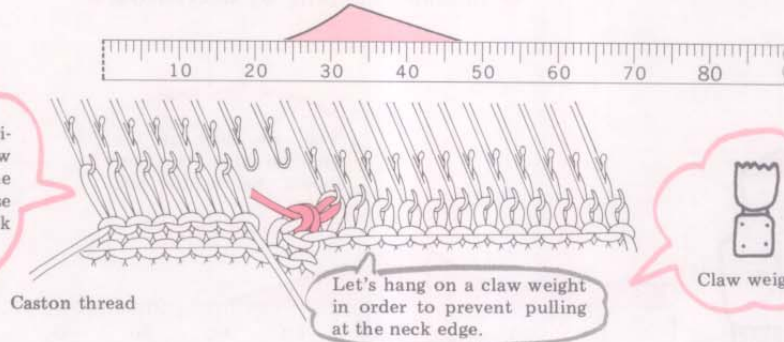

③ Knit 1 row to the right, decrease stitches for shoulder shaping. By repeating (2) and (3) complete the right shoulder. (The neck edge is also shaped by decreasing every alternate row at the side where the carriage is.)

Ensure that the needles in A position do not move!

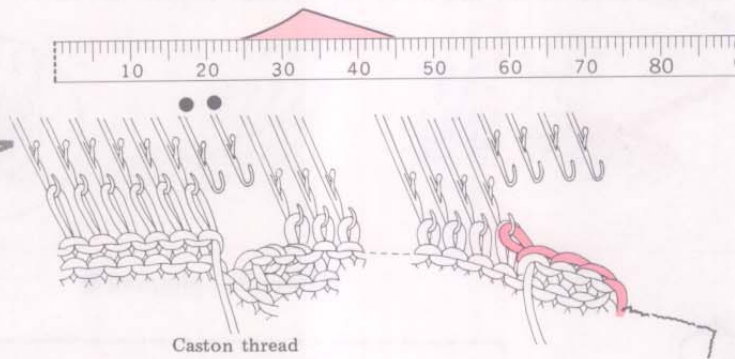

④ Working from the left return the stitches for the shoulder back to B position.

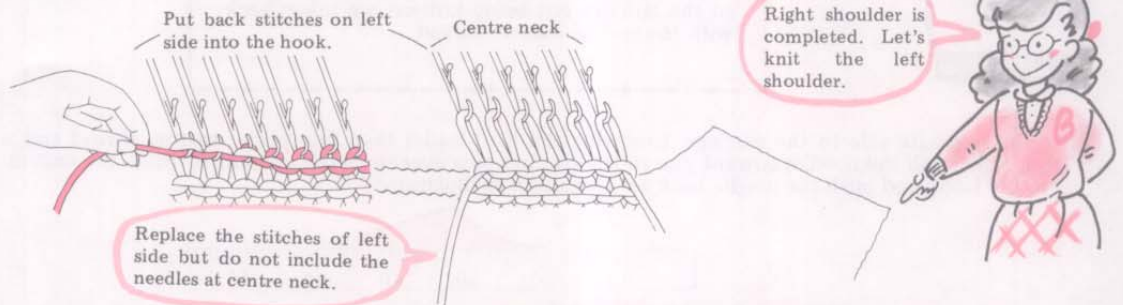

Undo the caston thread. Do not remove cast on thread from back neck stitches.

⑤

Remember to set the card to match the stitch for the left shoulder.

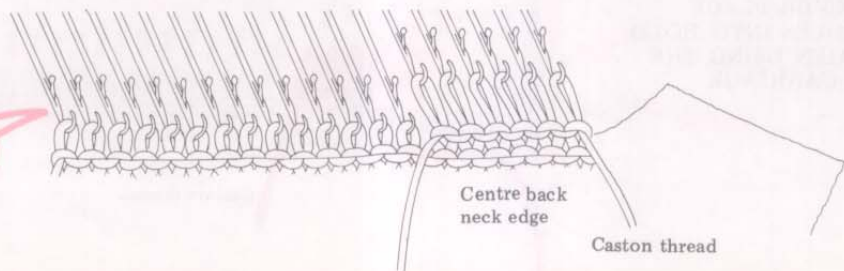



⑥ Operate the L-carriage then knit 1 row to left with the K-carriage. Cast off stitches for shoulder line following the Knit leader.



Work as for right side reversing shaping.

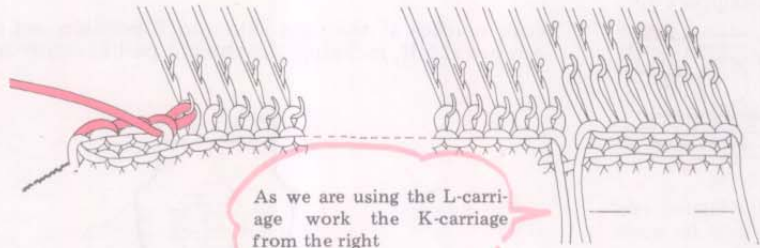

As we are using the L-carriage work the K-carriage from the right

⑦ Knit 1 row to right, decrease the stitches of neck line.

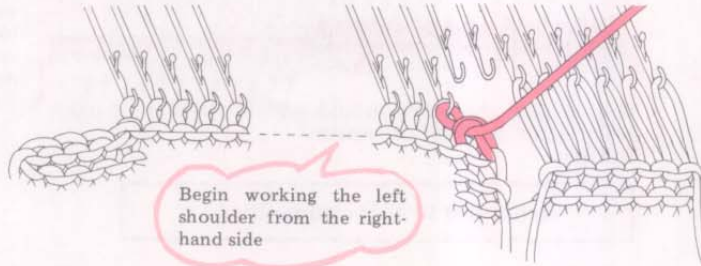

Begin working the left shoulder from the right-hand side

⑧ Return the stitches in A position to the needles.

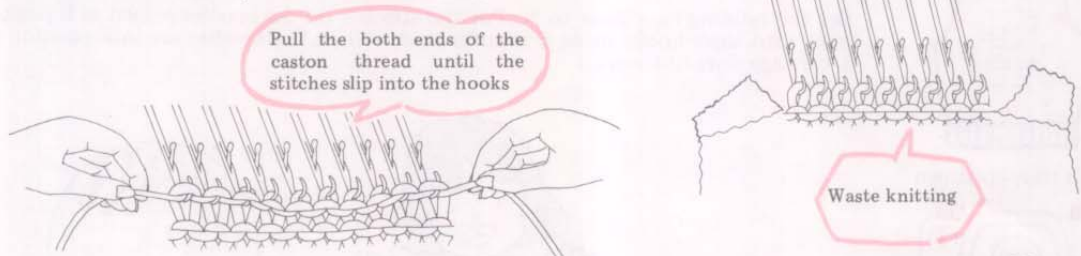

Pull the both ends of the caston thread until the stitches slip into the hooks

Waste knitting

## 6: HOW TO KNIT THE FRONT

Choose the Stitch Scale with the right datum line. Knit in the same way as back until front neck opening. Make a marker at the middle of the neck opening.

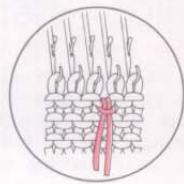

From this point the left and right sides are knitted separately. Ensure that you finish with 2 knit rows

Note card position!



● Waste knit stitches at left ●

Both trippers up

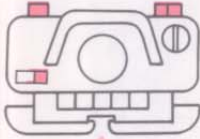

Set the holding cam lever to H for waste knitting

Push needles at the right side into E position, set carriage for hold and waste knit stitches at left, including the straight part at centre neck.

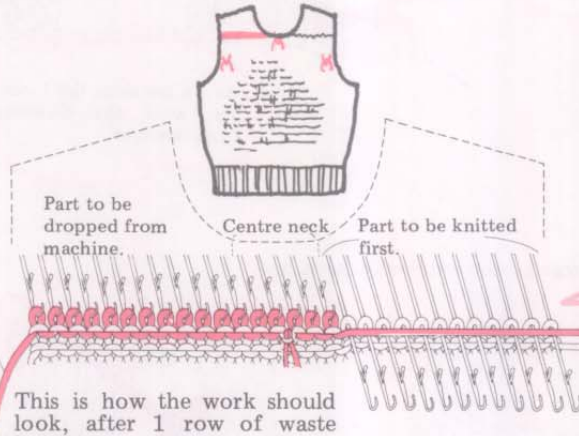

Knit 10 rows waste knitting and remove from machine. Push empty needles to A position

This is how the work should look, after 1 row of waste knitting.

Before you knit the waste knitting, bring forward the needles for right side of neck opening and the shoulder to E position.

Remember to note card position.

● Shape right neck and shoulder ●



Both trippers down

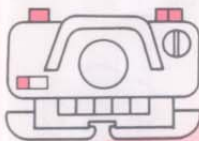

Set the holding cam lever to N. Put the stitches on the needles placed in E position back into their hooks using a transfer tool. (When the needles are in E position the L-carriage does not work.)

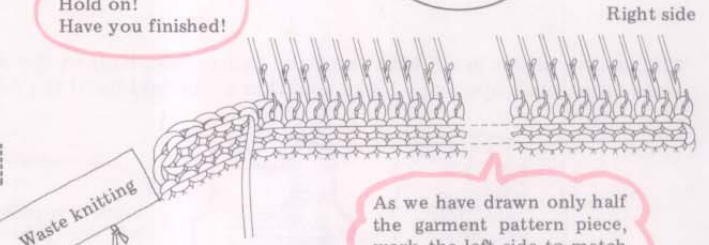
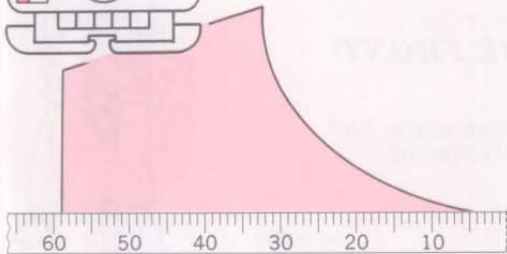
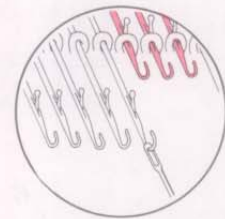

First operate the L-carriage and knit 1 row by the K-carriage. Then decrease the stitches dropped below the Stitch Scale. Continue shaping in the same way as the back.

As we have drawn only half the garment pattern piece, work the left side to match the right side but following the same drawing on the Knit-leader.

### ● Shape left neck edge and shoulder ●

Using the Feeding dial on the Knit-leader, adjust the pattern line to the Stitch Scale.



Arrange the correct number of needles shown on the Stitch Scale to B position and...

By turning the Dial return the sheet to the position before neck shaping began. Turn more than is required to start off with, then adjust to the exact position.

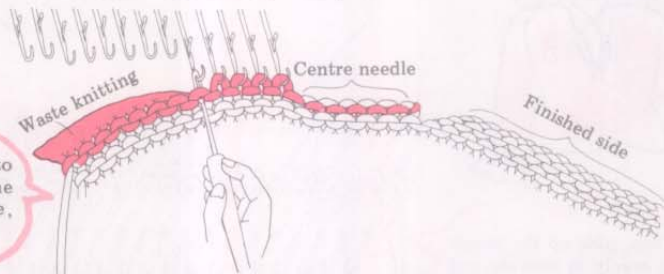
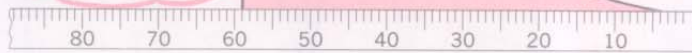

Fold the waste knitting to the back and omitting the straight section at centre, put back the stitches.

After the stitches have been picked up, return the punch card to the correct position. Set the card lock lever to ● and move the L-carriage to the right, set it to ▼ and operate the L-carriage working in the same way as the right side.

### ● Knitting the neckband ●

① Put the Stitch Scale along neck edge on drawing to determine the number of stitches required.

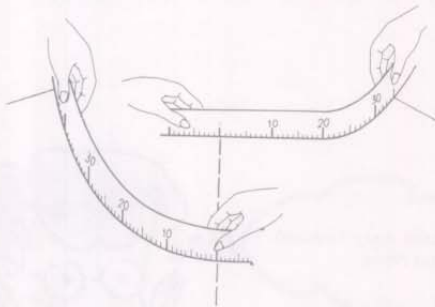

② Adjust the number of stitches to be in multiples of 4+2 and arrange the needles. Work finished edge for 2x2 and knit the neckband.

● Finished edge circular knitting ● ● 2x2 rib ●

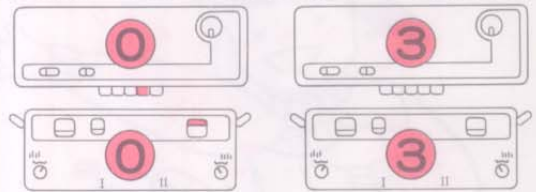

★ For knitting 2x2 rib with finished edge refer to page 140.

After completion of ribbing drop the ribber, remove the connecting arm and replace the sinker plate.

Both trippers down

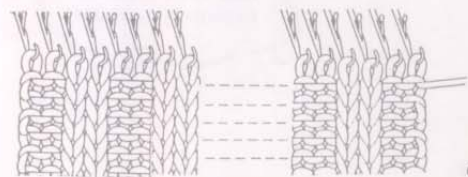

● Attach the neckband to bodice ●

- ① With the wrong side of the garment facing you, pick up the same number of stitches as the neckband from the neck edge of back and front except the seam allowance of the shoulders.

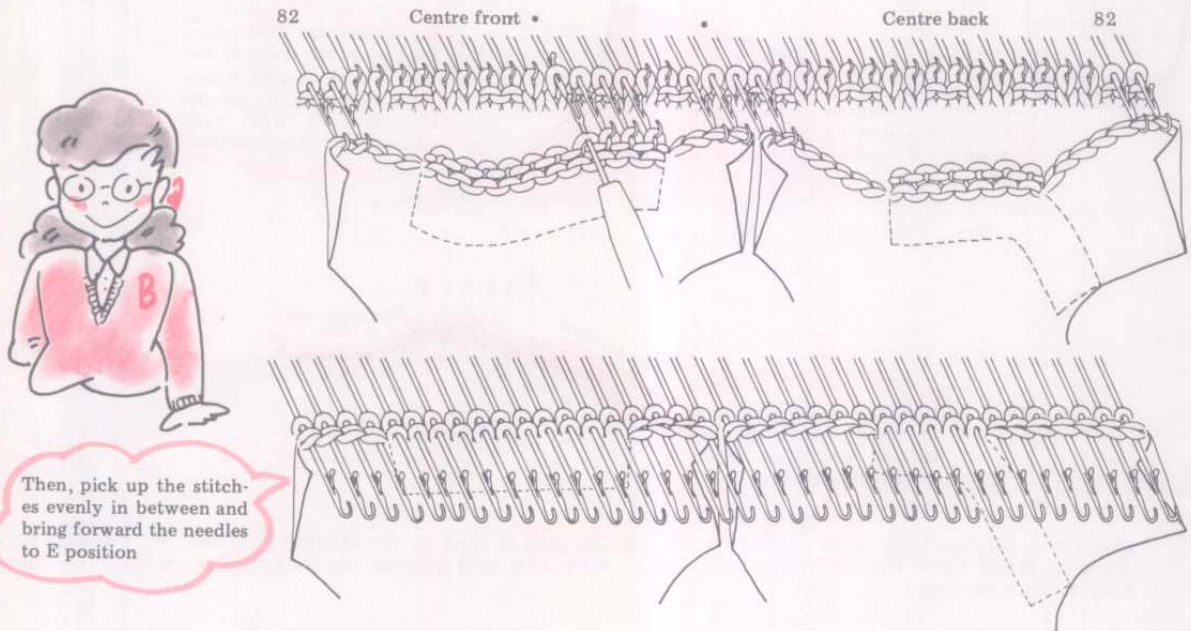

- ② Knit 1 row from right. Change to waste yarn, knit 2-3 rows and bind off the stitches. (For binding off stitches refer to page 72 ).

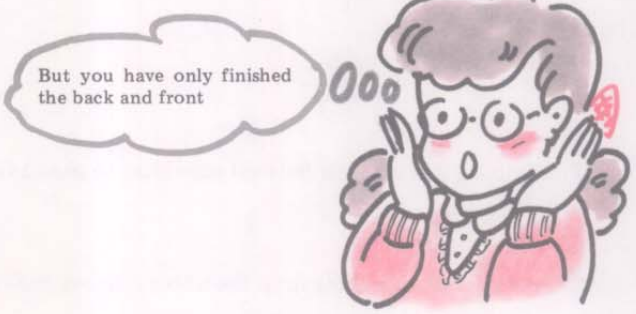

## 7: HOW TO KNIT SLEEVE

(Use the Stitch Scale with centre datum line)

Set the cuff of the sleeve on the sheet to the Stitch Scale. In this case it reads 35. So arrange 35 needles on each side of 0 in B position

Knit the cuff ribbing as waistband ribbing.



### ● Shaping sleeve sides by increasing ●

While you are operating the L-carriage work the increases following the Knit-leader.

Both trippers down

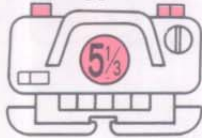

Change to the K-carriage and to required tension



When the Stitch Scale indicates so, increase a stitch by placing an empty needle at the side.

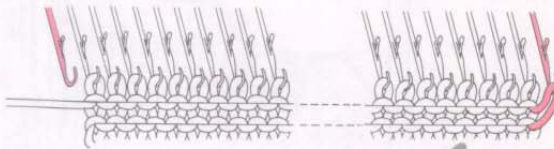

Increase in this way when you use sewing machine for seaming

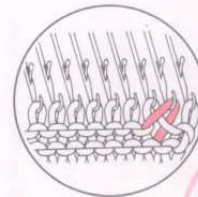

If you are sewing up by hand increase like this!

### ● Knitting the sleeve head ●

The Sleeve head is shaped by decreasing in the same way as the armhole of the bodice, remember to place markers. Bind off the remaining stitches.



Sew in the yarn ends to the wrong side



## 8: FINISHING

● Sew in the yarn ends before pressing ●

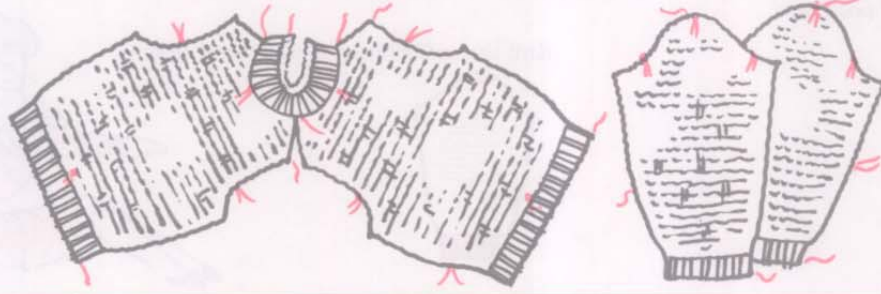

● Press each piece before sewing ●

Have ready Steam iron, pressing table, blocking pins, binding wire.

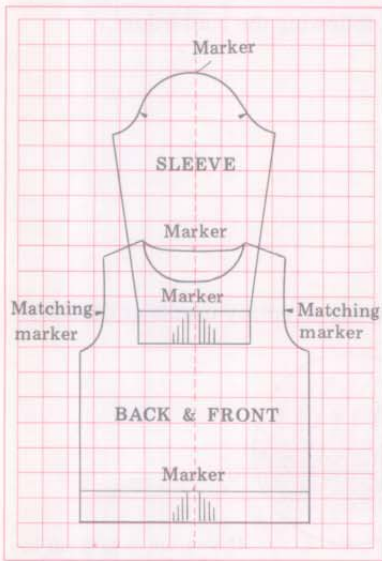

Trace the pattern on the sheet.

Sometimes the edges of a garment stretch, so thread the wires through the edges, adjust to correct length and press

Do not press ribbing



Sewing



Winding



① Pin out the garment as the drawing.

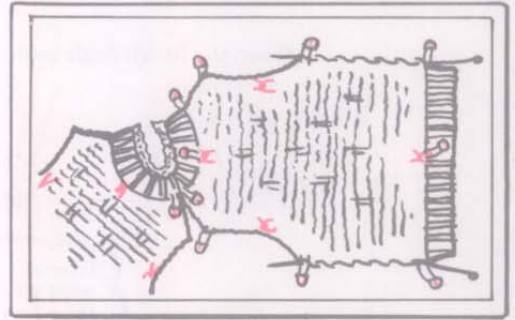

② You will need more pins along the curved edges.

③ You will need more pins along the curves of the armhole.

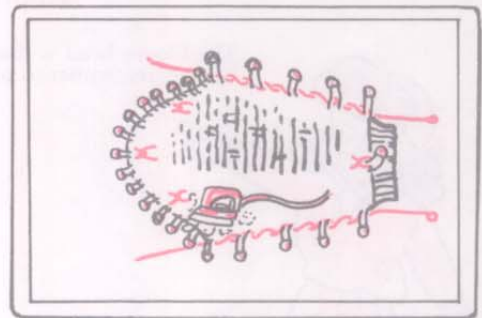
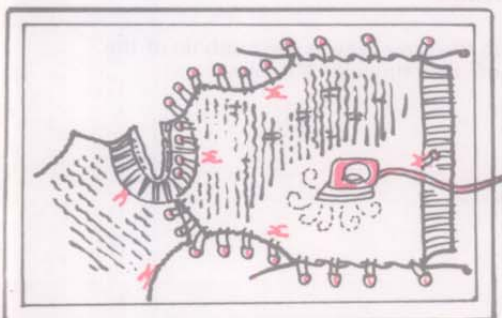



## Part 1

### ● Sewing shoulders, sides and sleeves by sewing machine ●

Check the measurement on your drawing.

Put the edges of each part together with the right sides facing and sew the edges by binding wire in winding manner. Baste inside the seam allowance.



You may sew by hand, too

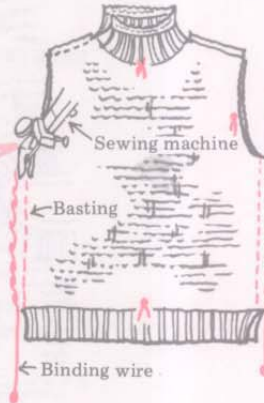

Check the measurement before you sew it by sewing machine

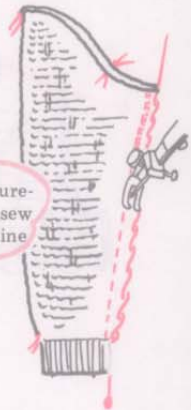

### ● Press the seams ●



### ● Attach sleeves ●

① Put the head of sleeve inside the armhole with the wrong side outside. Use the markers as a guide.

② Place pins evenly.

③ Baste inside and outside of seam allowance. Sew by a sewing machine at 0.5 cm in from the edge.

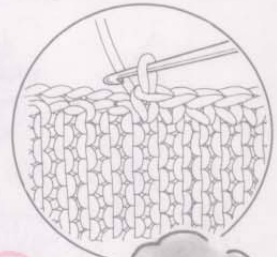
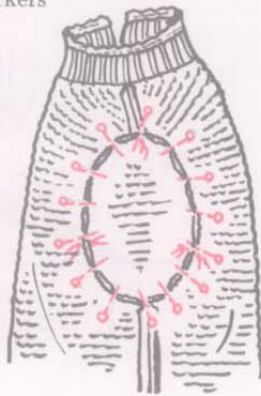

Neaten seam by 1 row of clochet!



Part 2

● Sewing the side and sleeve seams by sewing machine ●

① Place the shoulders right sides together. Thread the binding wire in winding manner, baste along the inside of seam allowance to hold it securely in position and sew by sewing machine.

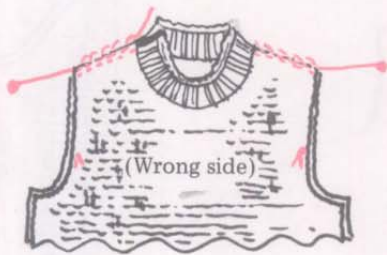

② Lay the back, front and sleeves on a flat surface with the wrong sides facing you.

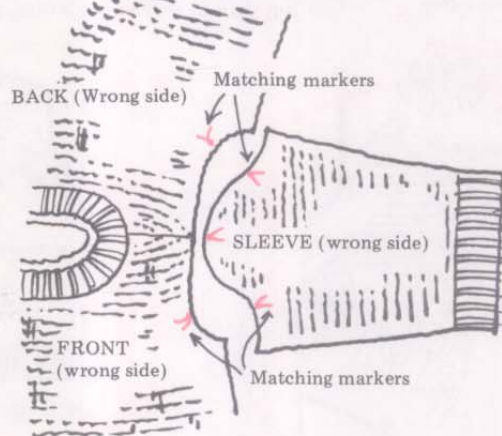

③ Pin into position.



④ While you remove the pins, thread the edges with the binding wire by winding method. Baste inside the seam allowance.

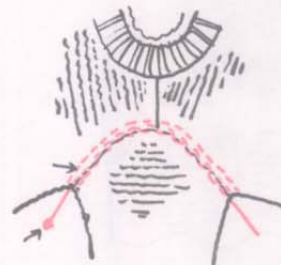

⑤ When basting is complete, sew 0.5 cm from edge using a sewing machine.

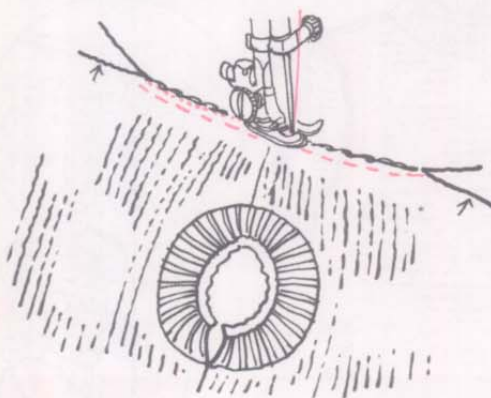

⑥ When sleeve is attached, press the seam.

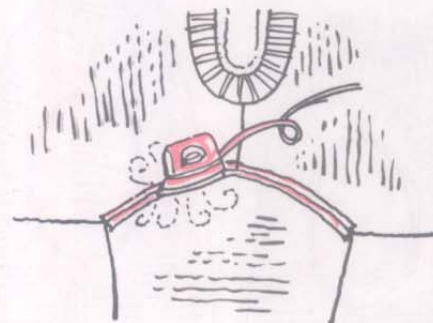



⑦ With the wrong side of the garment facing you, pin the underarms and the side seams.

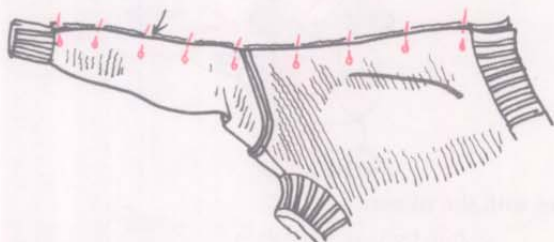

⑧ Baste.

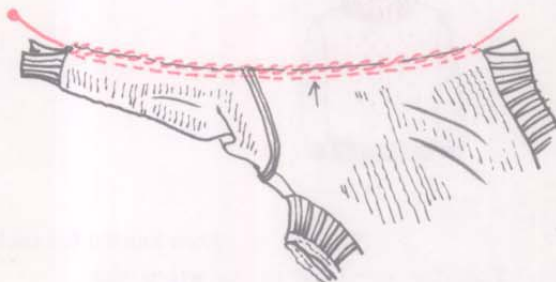

⑨ Sew 0.5 cm from edge.

After the sewing is complete draw out the binding wire.

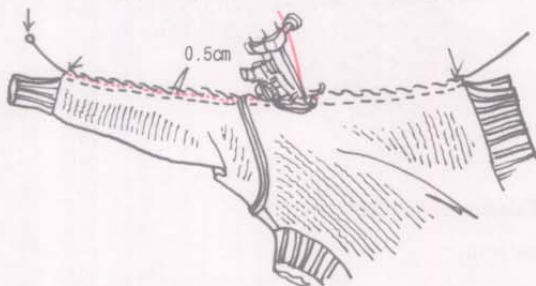

⑩ Press seams.

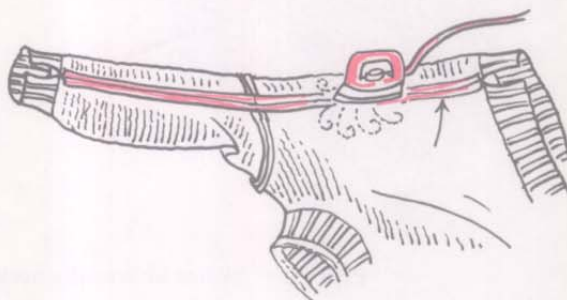

● Close neckband, waistband and cuff ribbing ●



● Sew 2x2 ribbing ●

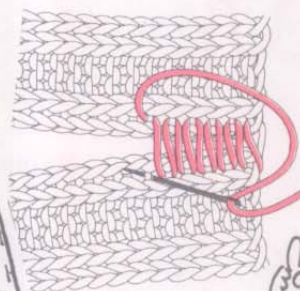

Next you have to sew the ribbed part!



● Holding the neckband ●



Let's make it double

PART 1 (When knitted the neckband with the ribber)

① Fold the neckband to the wrong side and insert the tapestry needle into the first stitch.

② Join by mattress stitch.

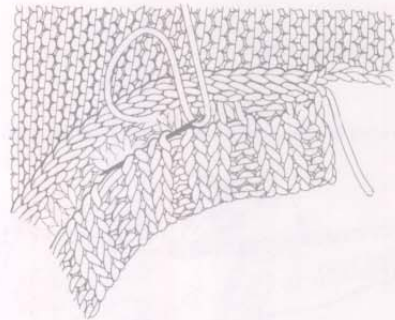
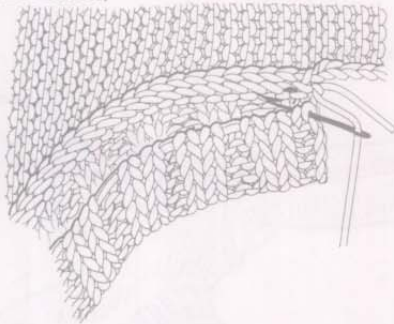

PART 2 (When knitted the neckband using the latchet tool)

① Fold the facing toward you insert the tapestry needle into the first stitch from the wrong side, pull through.

② Following these steps join by mattress stitch.

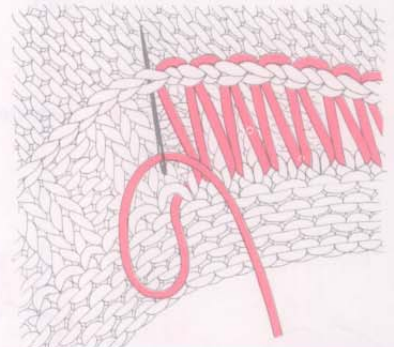
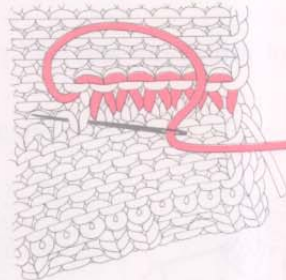
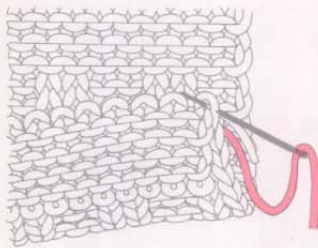

● Finishing touches ●



Turn to the wrong side and give final pressing.



Press lightly.

Don't try it on until garment is cool.



I can hardly wait to put it on!

*Step 5*



**Step 5**

# CHILD'S SWEATER (ROUND NECK WITH RAGLAN SLEEVES)

There are 4 sizes.  
Choose the size referring to the body measurement.



When you measure the chest, put 3 fingers under the tape do not make too tight.

Size	Chest
ES	58
S	62
M	66
L	70

**Measurement**

Around chest (C)
_____ cm

## 1: TRACING THE PATTERN ON THE SHEET

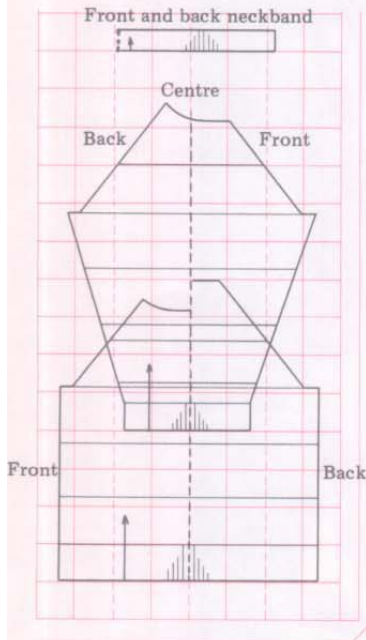

Let's trace the pattern you have chosen on the sheet.



Fit the centre line of the pattern to the centre of the Knit-leader sheet and trace as the diagram.

## 2: THINGS YOU WILL NEED



Have some more yarn in different shade ready for Waste Knitting

Size	Main yarn (blue)	Contrast colour (yellow)	Contrast colour (white)
ES	150g	50g	50g
S	200g	50g	50g
M	250g	50g	50g
L	300g	50g	50g



Work the colour sequence as the sheet.

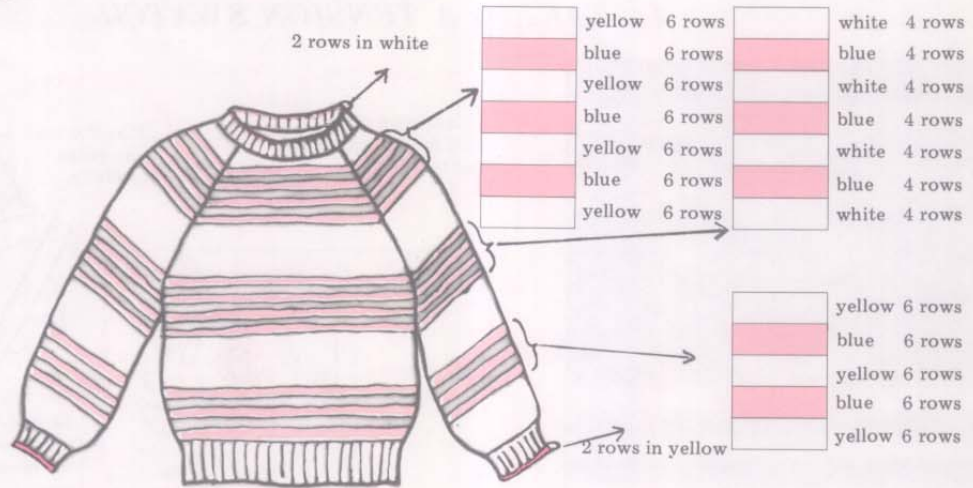

### 3: KNITTING POINTS

- ★ Knit the waist band and cuffs in 2 x 2 rib.
- ★ Remember to place a yarn marker at each point showing M.
- ★ Knit the sweater in stripes and use the right side of the garment.

You can work in the same way as the sweater in Step 4.



① **Waist band**  
Knit in 2 x 2 ribbing.

② **Underarm**  
Knit evenly in stripes.

③ **Raglan**  
Shape it by decreases.

④ **Back neck opening**  
Remove with waste knitting.

⑤ **Front neck opening**  
Shape by decreases

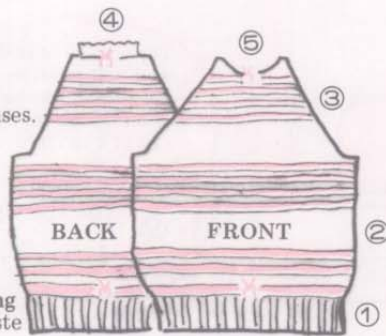

① **Cuff ribbing**  
Knit in 2 x 2 ribbing.

② **Under side of sleeve**  
Knit in stripes shaping sides by increases.

③ **Raglan**  
Shape it by decreases.

④ **Neck edge**  
Shaped by decreases



#### 4: TAKING A TENSION SWATCH

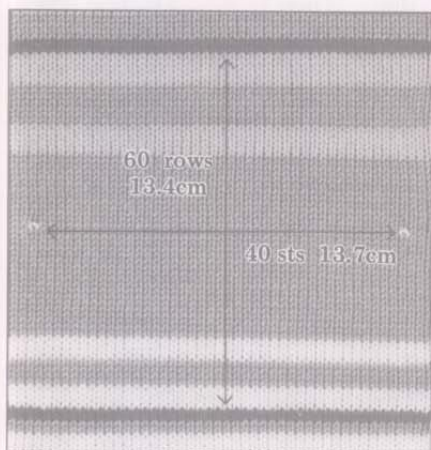

This tension gauge is only for this yarn and this tension dial.

Take the tension gauge carefully.



##### ● Tension Gauge (an example) ●

60 rows  
13.4 cm



40sts. 13.7 cm

Be sure to write down the measurement.



Let's set the regulators on the Knit-leader 60 rows length, 13cm 4mm ...

Stitch Scale 13

Choose the Stitch Scale with the centre datum line

No. 13 with 135 ~ 137 isn't it?

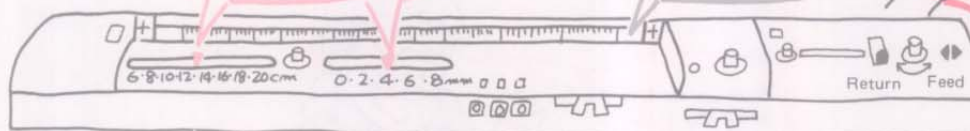

#### 5: KNITTING THE BACK

##### ● Make the number of stitches for 2×2 rib multiples of 4+2 ●

Roll the sheet and adjust the base of the pattern piece to the Stitch Scale

The number of stitches is 51. And so the number of stitches for 2 x 2 rib should be in multiples of 4 + 2, arrange 51 needles on each side of 0 to B position.



● Start with the waistband and knit to underarm ●

Perfect edge

2 x 2 rib

yellow (4 rows)  
blue (4 rows)  
yellow (4 rows)  
blue (4 rows)  
yellow (4 rows)  
blue (4 rows)  
yellow (4 rows)

White (4 rows)  
Blue (4 rows)  
White (4 rows)  
Blue (4 rows)  
White (4 rows)  
Blue (4 rows)  
White (4 rows)

Yellow (6 rows)  
Blue (6 rows)  
Yellow (6 rows)  
Blue (6 rows)  
Yellow (6 rows)

● Shape raglans ●

I have to decrease the stitches along the pattern line, right?

Waste Knitting

Marker

Allow 2 stitches for the seam allowance, place marker at centre and finish with waste knitting

Here I have to bind off more than 2 stitches.

Allow 1 stitch for seam allowance when sewing with a sewing machine

It is better to use this method when sewing by hand.

## 6 : KNITTING THE FRONT

Knit to neck line



The front is knitted, the same way as the back.

### ● Shape left neck edge first ●



Set the holding cam lever to H ...



Work to neckline ending with the carriage at the left.

Push needles at right to E position.

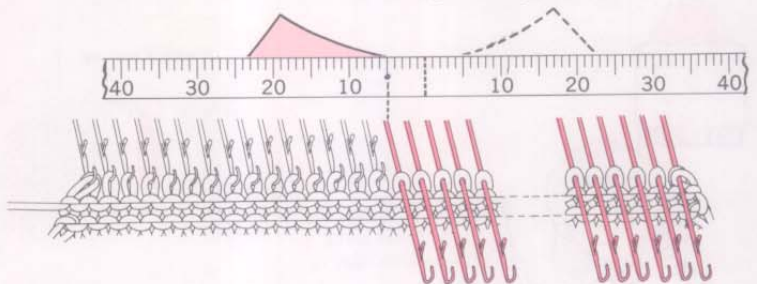

Knit 1 row and decrease the number of stitches which drop below the Scale.

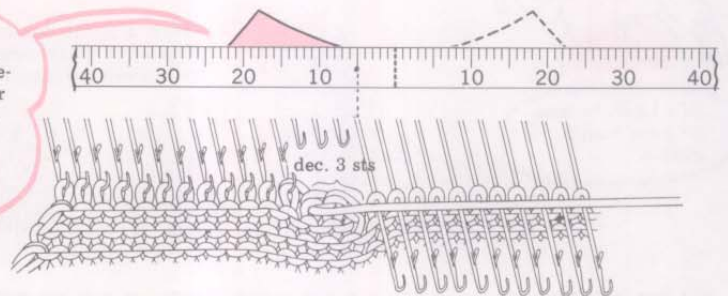

Knit 1 row and decrease the stitches which drop below the Scale.

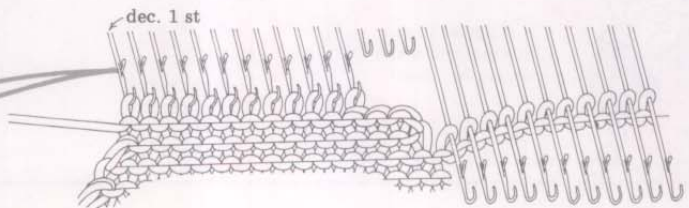



Knit 1 row and decrease the stitches which drop below the Scale.

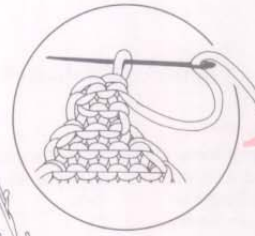
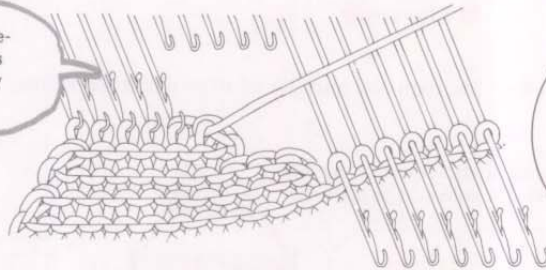

Continue decreasing along the pattern line then pass yarn through the remaining stitch.

● Shape right neck edge ●



Push the needles of centre neck to D position. Waste knitting and remove from machine.



Both trippers up



Adjust the sheet to the base of neck line.

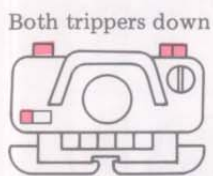

Both trippers down



Set the holding cam lever to N. Both trippers to working position and knit in the same way as the left side.

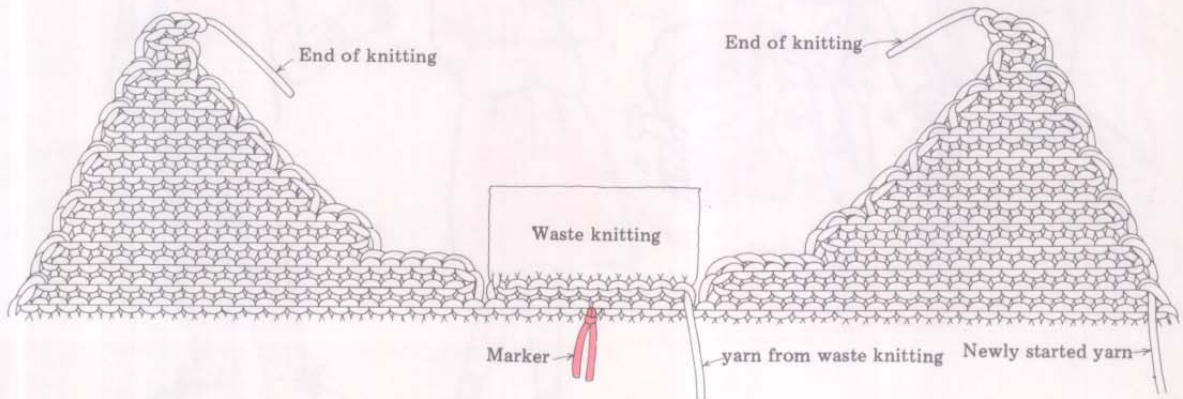
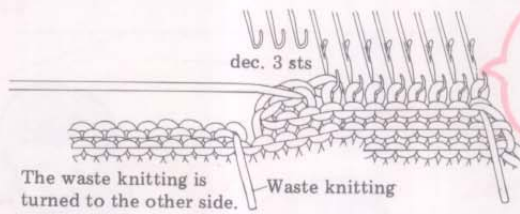

## ● Sleeves ●

For the cuff ribbing, knit the required number of rows using the ribber.



After you have finished knitting cuff ribbing knit the sleeve increasing stitches reading the Stitch Scale. Be careful not to make two of the same sleeves.

To increase a stitch add 1 empty needle at the side of the carriage on.

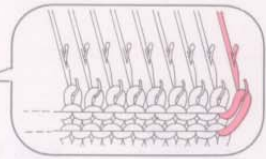
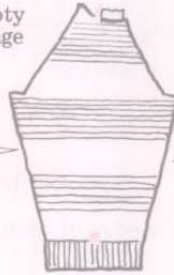
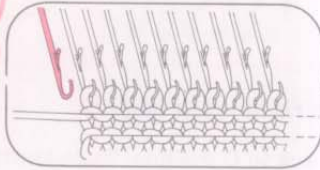

The colour sequence should match the back and front.

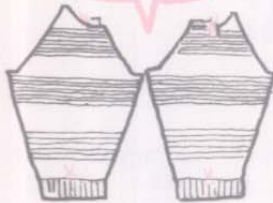

Seam allowance = 2 stitches

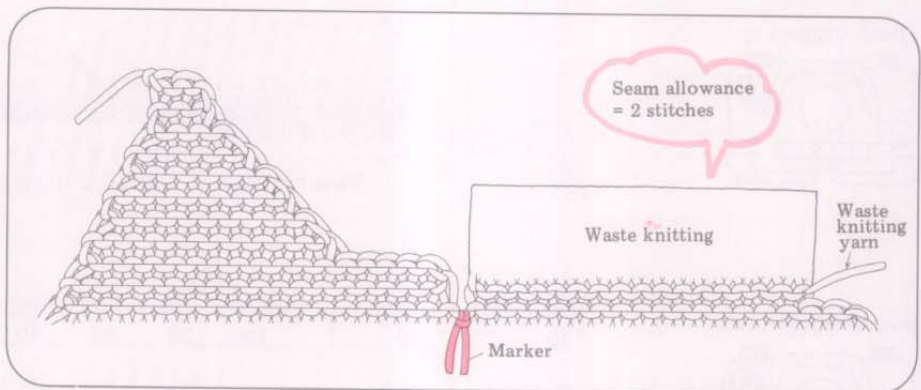

## 7: FINISHING

● Sew in the yarn ends and press ●

Trace the outline of the pattern onto the sheet. Do not forget to place the markers.

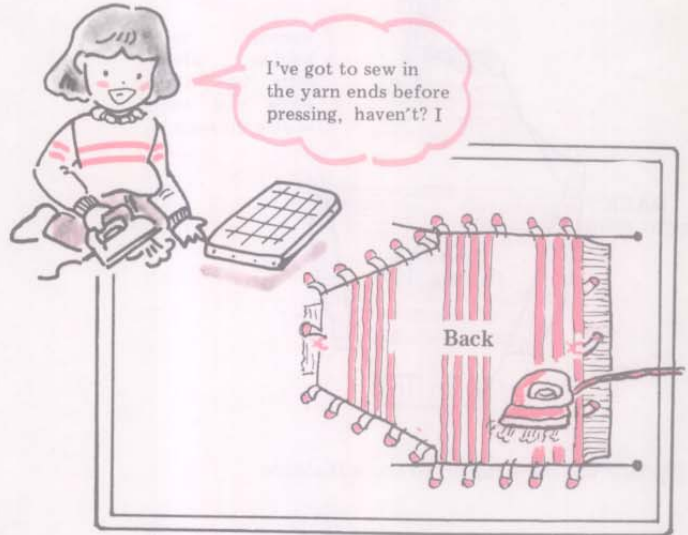
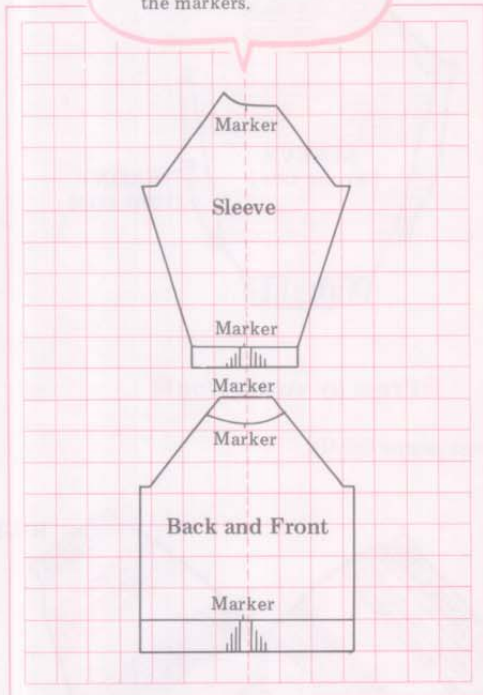

Spread the paper on the pressing table and pin adjusting the garment to the pattern line.

After pressing is complete attach sleeves to the back and front.

You haven't knitted the same sleeves, have you? Press out to the drawing.

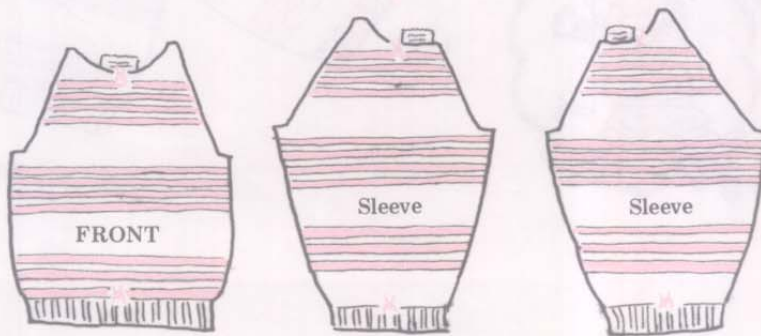

● Sewing by sewing machine ●

① Place back and sleeve raglans together with right sides facing. Baste then sew by sewing machine.

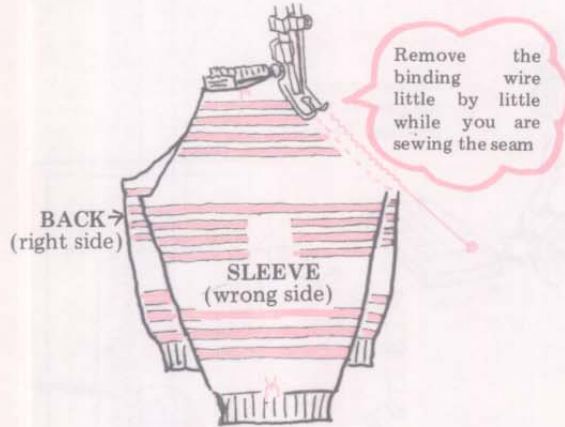

② Place front and sleeve raglans together. Baste and sew by sewing machine.

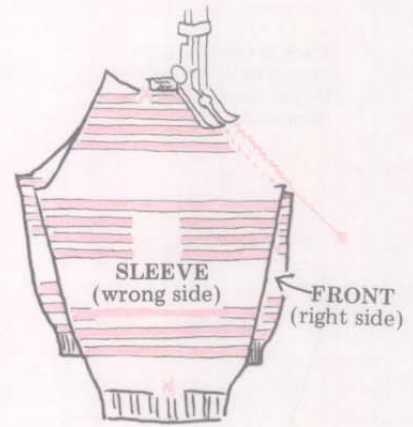

③ Place the back raglan to the left sleeve.

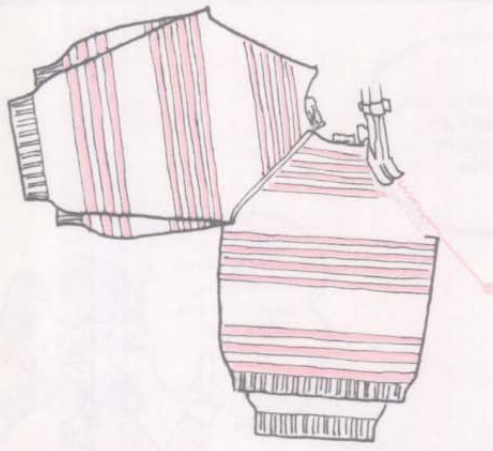

● Press by steam iron ●

④ Press seams lightly

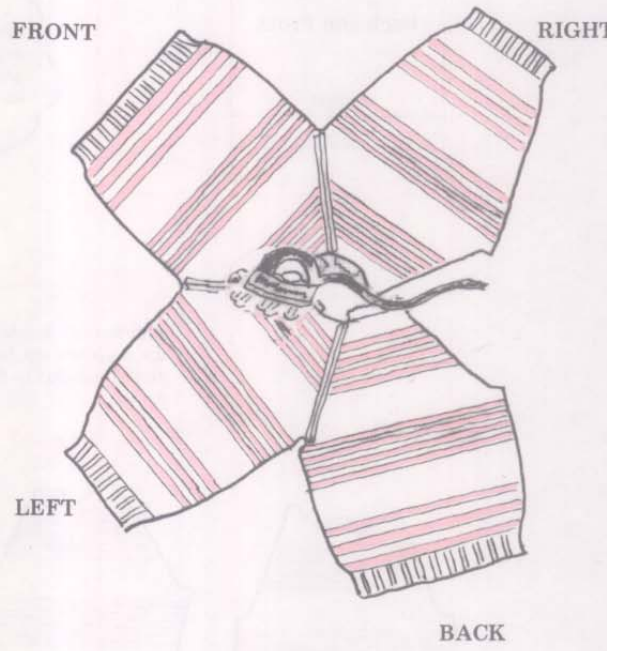

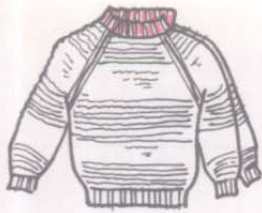

### ● Knitting the neckband ●

- ① Place the Stitch Scale around the neck edge and determine the number of stitches required. Adjust the number to multiples of 4 + 2 stitches and arrange that number of needles. (For 2 x 2 rib with finished edge refer to page 140).

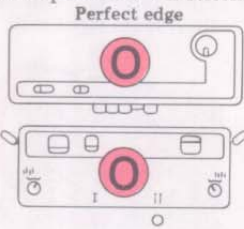

- ② Though the finished edge on page 140 was worked in 1 and half rounds of circular knitting, in this case you will need to knit 2 rounds.

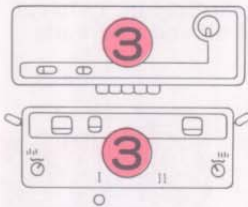

Set the carriage as for waist-band ribbing and knit 2 rows in contrast colour for the finished edge. Change to the main yarn and knit the required number of rows cut the yarn leaving an end 6 times the width of knitting on machine.

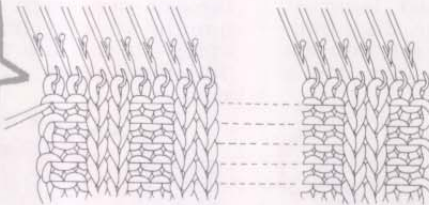

- ③ Transfer the stitches on the ribber to the main bed. Lower the ribber and remove the connecting arm and replace sinker plate.

### ● Attach the neckband to back and front ●

- ① With the wrong side of work facing you, place on each end, shoulder point of back and front matching the markers (Pick up same number of stitches as neckband centre).

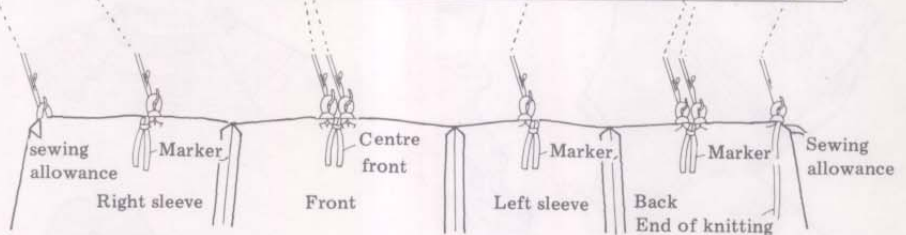
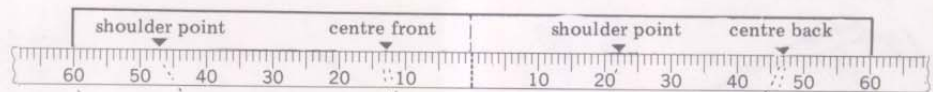
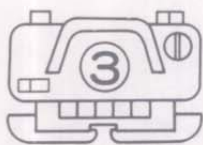

- ② Pick up the stitches evenly and place onto needles and bring out the needles to E position.

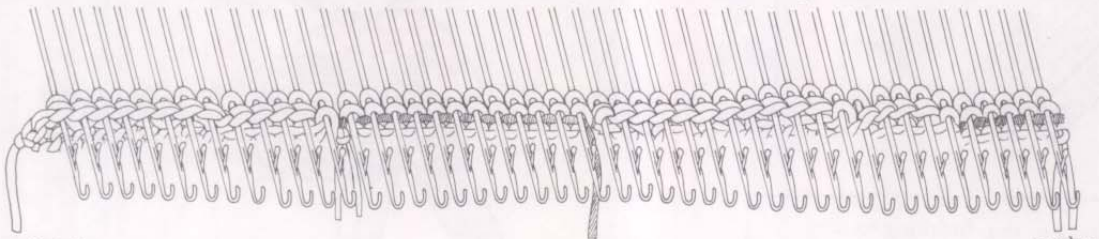

leave sewing all

Waste knitting

marker

- ③ Knit 1 row from right side. Knit 2 ~ 3 rows in waste yarn and bind off the stitches. (Refer to page 72 binding off stitches)

● Finish 2×2 rib of neckband ●

① Hold the garment with right side facing you, insert the tapestry needle into the 1st stitch from right side, then to the 2nd stitch from the wrong side.

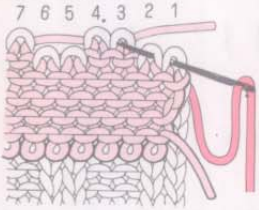

② Pull the tapestry needle through. Insert the needle into the 1st stitch again and to the 3rd stitch from right side.

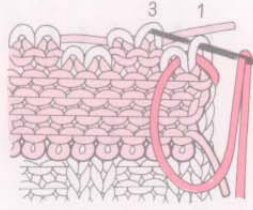

③ Pull the tapestry needle through. Insert the needle into the 2nd stitch from right side and into the 5th stitch from wrong side.

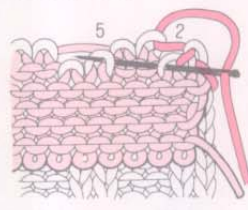

④ Pull the tapestry needle through, insert the tapestry needle into the 3rd stitch from wrong side and to the 4th stitch from right side.

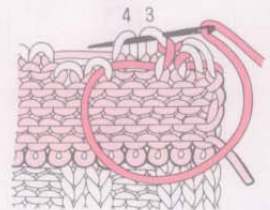

⑤ Pull the tapestry needle through and insert it into the 5th stitch from right side and into the 6th stitch from wrong side.

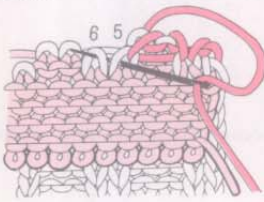

⑥ Pull the tapestry needle through and insert it into the 4th stitch from wrong side and into the 7th stitch from right side.

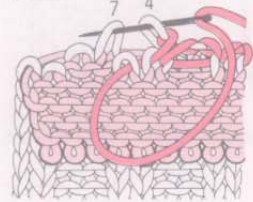

⑦ Repeat 3 ~ 6 until the last stitch. For the last time insert the tapestry needle as the diagram. (After all the stitches have been bound off unto the waste knitting.)



● Sew remaining Raglan from underarm to under side of sleeve using a sewing machine, and mattress stitch the 2×2 ribbing ●



For the finishing touch refer to the Lady's sweater

# Step 6

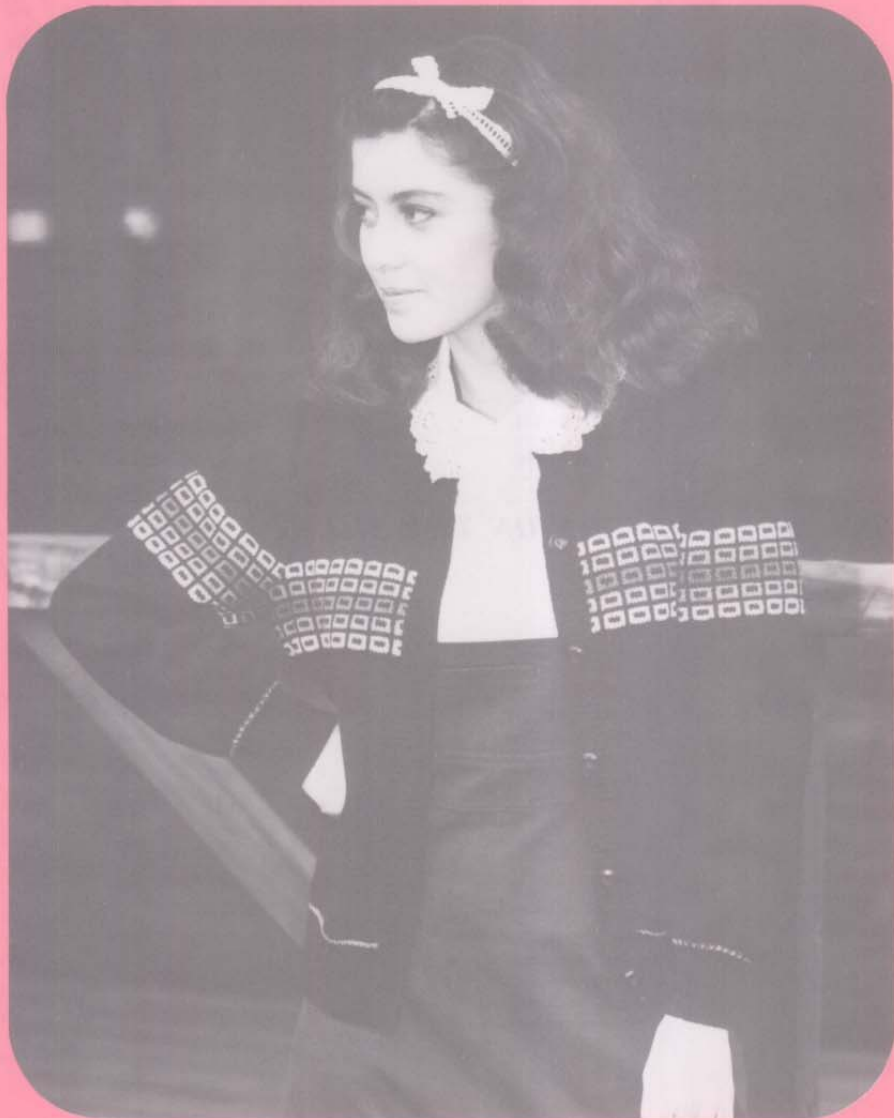

**Step 6**

# LADY'S CARDIGAN



The pattern has 5 sizes and I'm to choose one of them based upon my bust measurement, isn't it?

Use the pattern for lady's cardigan.



Choose the correct size for your body measurements.

Size	Chest
ES	81~86
S	86~91
M	91~96
L	96~101
EL	101~106

Write down your measurements.

Bust	Length	Sleeve Length
cm	cm	cm

## 1: TRACING THE PATTERN ON THE SHEET

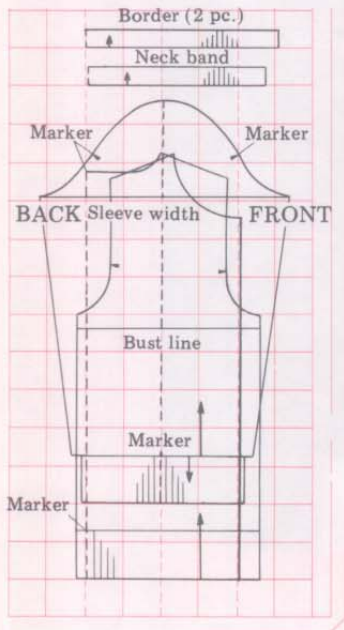

Trace the pattern you have chosen on to the sheet.

Draw the multi-coloured pattern area as the pattern pieces in the desired position.

## 2: THINGS YOU WILL NEED

Size	Main yarn (black)	Contrast colour (yellow)	Contrast colour (orange)	Contrast colour (green)
ES	350g	50g	50g	50g
S	400g	50g	50g	50g
M	400g	50g	50g	50g
L	450g	50g	50g	50g
EL	450g	50g	50g	50g

Have some yarn for waste knitting.



Any odd pieces of yarn will do!



Have 6 buttons ready.

1.8cm

Each part is traced on one sheet.  
112



### 3: KNITTING POINTS

- ★ The section across the bust is in multi-colour tuck stitch. The plain side is the right side.
- ★ The lower edge, cuffs and neckband are knitted in 1x1 ribbing.
- ★ Be sure to make a marker at the position marked.

- ① Waist band ribbing  
Knit in 1x1 rib.
- ② Hem to under arm  
Knit without shaping. A little before armhole work in multi-colour tuck.
- ③ Armholes shaping by decreasing.
- ④ Shoulder and neck opening  
Shoulder shaping by partial knitting and the neck opening by decreasing.
- ⑤ Neckband  
1x1 ribbing

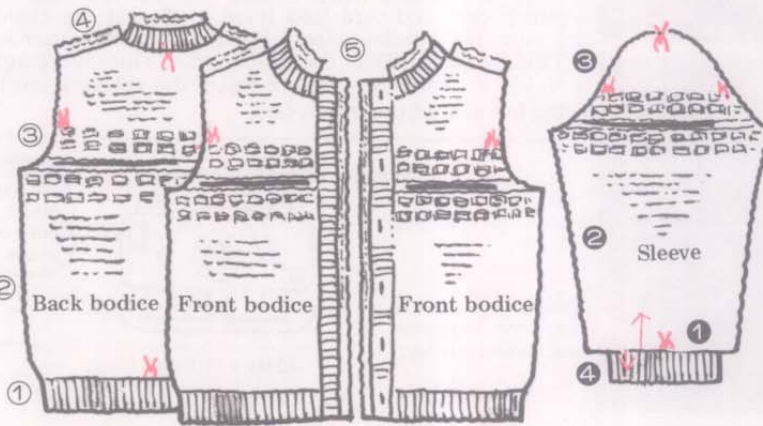

- ① Sleeve  
Knit the sleeve from cuff.
- ② Sleeve shaping  
By increasing. Begin multi-colour pattern below the armhole to match Back and Front.
- ③ Sleeve  
Shaped by decreases and the remaining stitches are bound off.
- ④ Cuff ribbing  
Pick up from the cuff decreasing stitches and knit in 1x1 rib.

### 4: TAKING A TENSION GAUGE

#### ● Making a punch card or electronic sheet ●

##### ● Punchcard ●

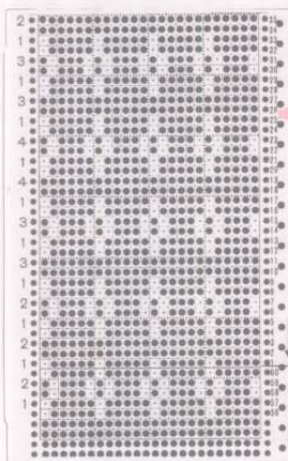

Punch the blank card like this.

Starting line  
For how to make a punch card refer to p. 154.

##### ● Colour for each number ●

- 1 ..... Black
- 2 ..... Yellow
- 3 ..... Red
- 4 ..... Blue

These numbers represent the colours.

##### ● ELECTRONIC SHEET ●

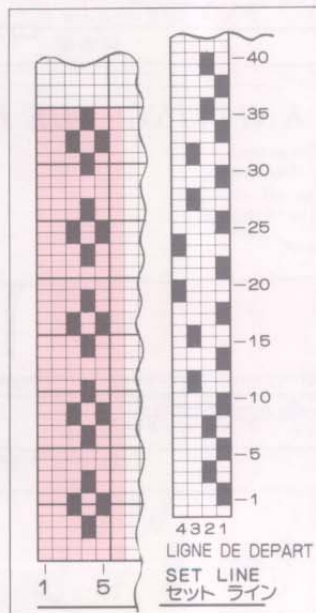

##### ● Programme ●

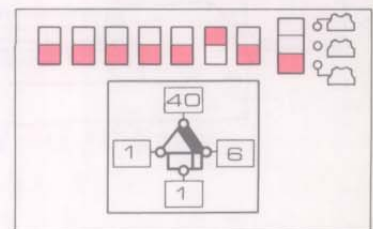



Since the tension gauge can differ from machine to machine, remember to make a new one every time and measure it correctly

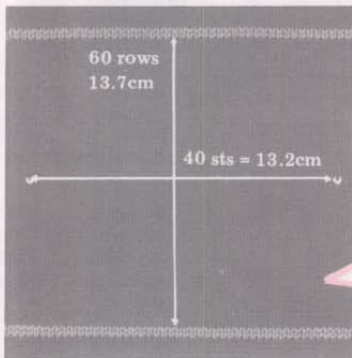
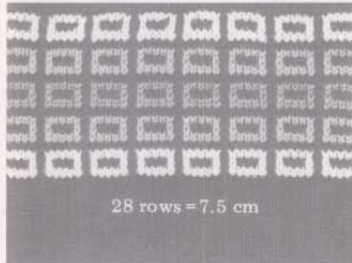

The cardigan has 40 rows of multi-colour tuck stitch and tuck stitch is apt to have more rows to the cm. Therefore you must make 2 tension swatches, one in stocking stitch and one in tuck stitch. Take the two sets of measurements and when you come to the tuck part set the Knit-leader accordingly. As there is only a small amount of multi-colour tuck across the garment there is no need to adjust the stitches, however if the whole of the Back / Front of sleeves were in tuck you would have to use the stitch gauge for tuck.

#### HOW TO KNIT MULTI COLOUR TUCK STITCH PATTERN

Work in stocking stitch ending with the K-carriage on the left. Insert the punch card and card lock lever to ●, set the change knob to KC. Knit 1 row, the needles select. Set the card lock lever to ▼ and depress both TUCK buttons. Push the rubber wheels into working position. Work as you would in stocking stitch changing the colour according to the number of the left side of the punch card.

#### ● Tension gauge (an example) ●

60 rows = 13.7 cm



40 sts = 13.2 cm

This tension gauge is only for this yarn and tension setting.

Be sure to make a note of the gauge.



Set the regulator for 60 rows measuring 13.7cm.

#### Stitch Scale

use the Stitch Scale for left datum line.

It's the scale NO. 13 for 132-134, isn't it?

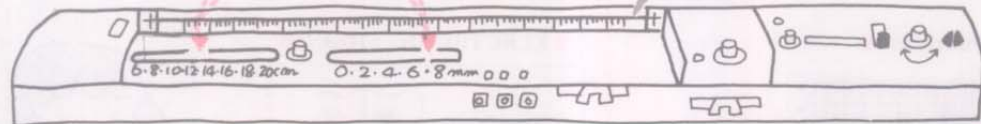

### 5: KNITTING THE BACK

Turn the feeding dial and adjust the base line of the pattern piece to the Stitch Scale.

As the Stitch Scale reads 63, arrange 63 needles on each side of O in B position.

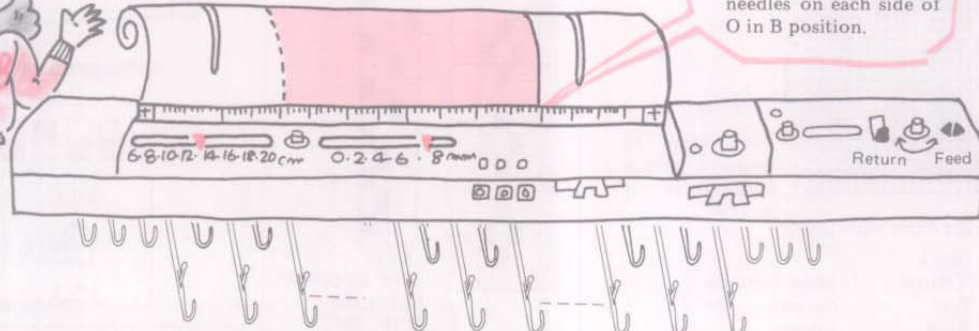



Stocking stitch

● Waistband ribbing and Back/Front to armholes ●

For waistband ribbing add 1 stitch to the number you have read on the Stitch Scale. (This ensures that the stitches on the Front match the Back.) The last 2 rows are knitted with contrast colour yarn.

From the 1x1 rib to tuck pattern position work in the same way as for Step 3



Perfect edge



1 x 1 rib

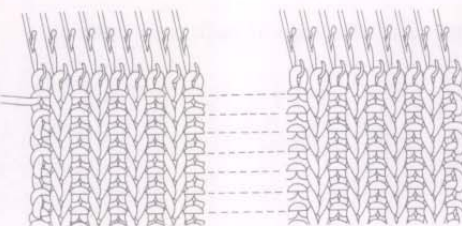

● Knit in multi-colour tuck stitch pattern ●



After multi-colour tuck has been finished set the change knob to N.L.



From here we use the card and knit in multi-colour tuck stitch pattern.

Shape the armholes in exactly the same way as for Step 3.



While you are knitting in this pattern you have to shape armholes by decreases. Then knit evenly to the shoulder point.

● Shoulder shaping by partial knitting ●



This is what the sheet looks like when you get to the shoulder point.

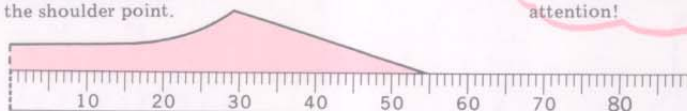

Now you are going to use the technique of partial knitting for the first time. Pay attention!



① Knit 1 row, bring forward to E position the needles of the part that has dropped below the Stitch Scale at the opposite side of the carriage position.

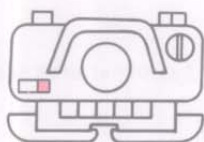

Set the holding cam lever to H...

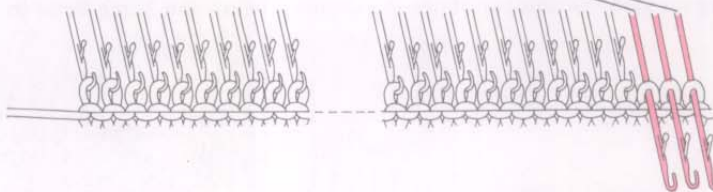

\* You have only drawn the right side of the Back pattern piece so you must work the left side to match.

- ② Knit 1 row. Pass the yarn under the first needle at E position as the diagram and bring forward the needles to E position on the opposite side.

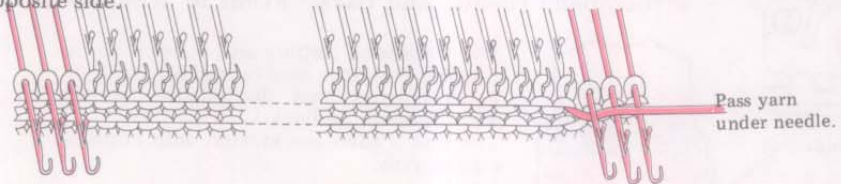

- ③ By repeating the above, knit until the base of back neck opening.

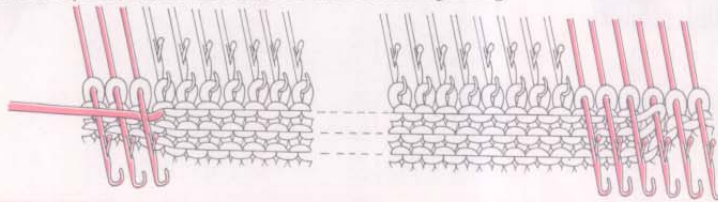

● Shape neck opening ●

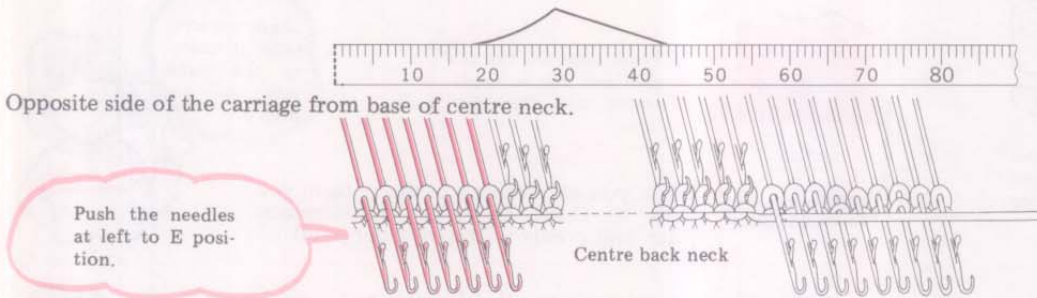

- ① Knit 1 row. Bring forward the number of needles dropped below the Stitch Scale to E position. Decrease 1 stitch at neck edge.

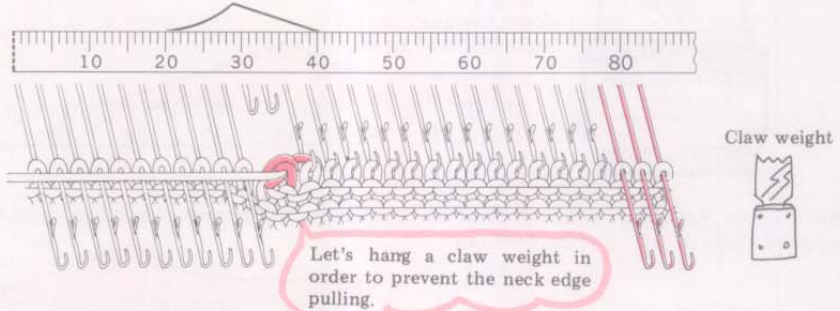

- ② Knit 1 row to the right. Place yarn under the nearest resting needle and knit 1 row to the left.  
 ③ Bring forward the number of needles dropped below the Stitch Scale to E position. Decrease 1 stitch at neck edge.

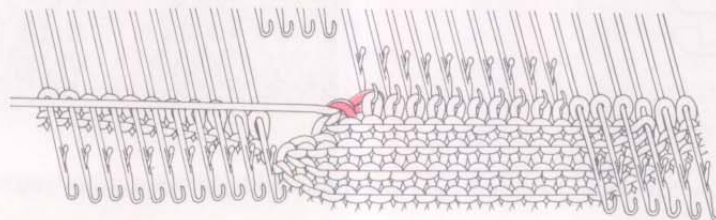



What is smoothing the stitches?

Look at the picture below. Some needles have two loops on, do you see?



When you join the shoulders it is hard for beginners to see the stitches clearly. So we knit 1 row across. This operation is called smoothing the stitches.

④ By repeating previous operation, the pattern line drops below the Stitch Scale and all the needles are in E position. Next, push back the needles to D position and knit 1 row across to smooth the stitches.

After knitting 1 row cut yarn leaving the end about 3 times the width of the knitting on the machine.

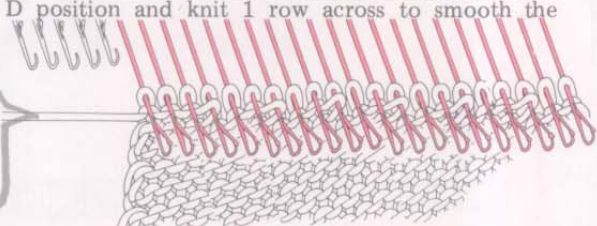

⑤ Waste knit. Knit about 10 rows in waste yarn and remove from machine. Push back the empty needles to A position.

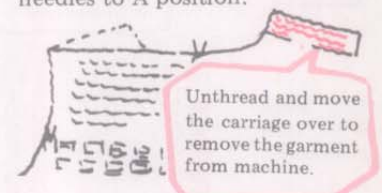

### ● Knitting the left shoulder ●



Excluding the needles at the centre of neck push the needles at left into D position.

① Knit the left shoulder to match right shoulder reversing shaping.

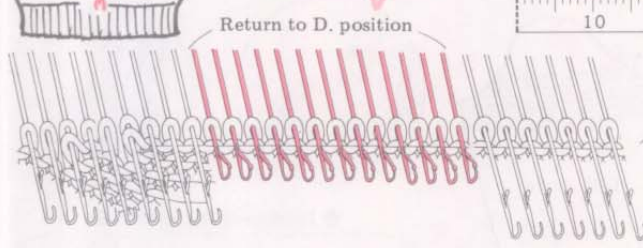

Waste Knitting

The carriage should be on the right hand side!



② Knit 1 row to the left. Yarn under the inside needle in E position and knit to the right. Bring forward to E position the number of needles dropped below the Stitch Scale. Continue knitting as for the right side.

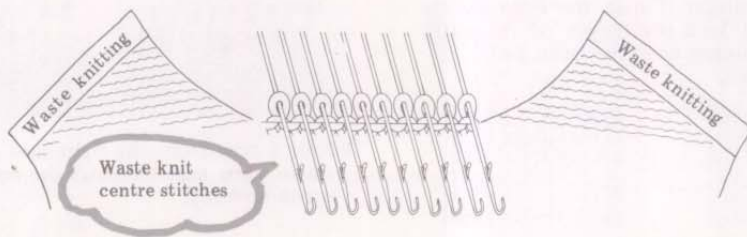
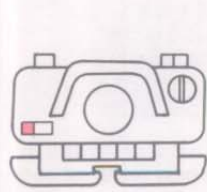
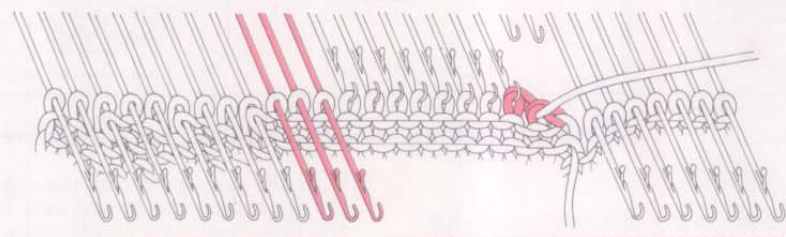

## 6: HOW TO KNIT THE FRONT (FIRST KNIT THE LEFT FRONT WHICH IS ON THE SHEET)



Knit the waistband using the ribber or latchet tool

Draw onto the Knit-leader sheet only the left front, you must work the right front reversing the shapings. Knit the left and the right front separately in the same way as the back.

End stitch is for seam allowance

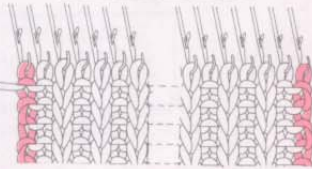

This is where you pick up for the buttonhole and button band.

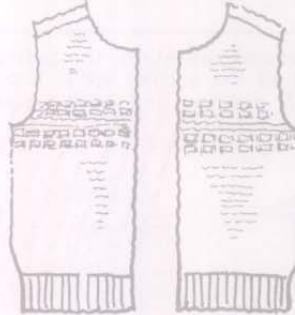

Remember you have to knit a left and a right side.

## 7: KNITTING THE SLEEVES



Adjust the cuff line to the Stitch Scale and read the number of stitches for the cuff ribbing. Arrange the needles in B position accordingly, using waste yarn, knit a few rows then knit with main yarn.



Work from the cuff to the sleeve head as Step 4

Perfect edge

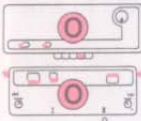

1 x 1 rib



● Decreasing for sleeve head ●

Decreasing more than 2 sts.    Decreasing 1 st.

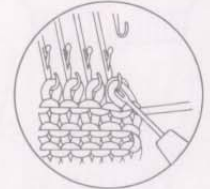
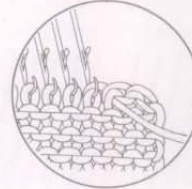

● Increases for sleeve ●

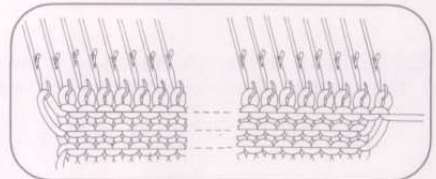

● Knit cuff ribbing and attach to the edge of sleeve ●

① Adjust the Stitch Scale to the cuff ribbing line and read the number of stitches, caston the required amount using the ribber. Finish the edge by circular knitting. And knit the length of the cuffs. Then transfer the stitches onto the main bed.

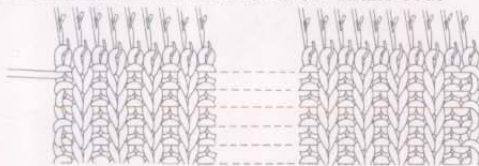

② With the wrong side of the sleeve facing you and the waste knitting turned over pick up the stitches and distribute them evenly along the row.

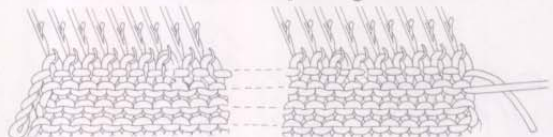

③ Knit 1 row from the right side. Knit 2 or 3 rows in waste yarn and bind off the stitches. Remove the waste knitting.

Replace the shoulder stitch back onto main bed with right sides facing.

● Join shoulders using a tapestry needle ●

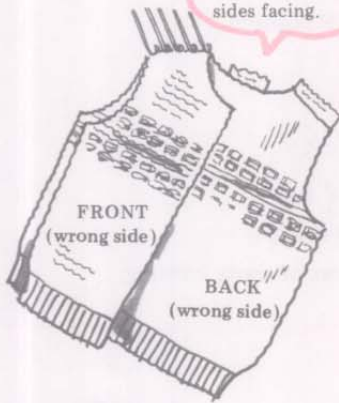

● How to pick up shoulder stitches ●

By holding the garment with your left hand replace the stitches back onto needles.

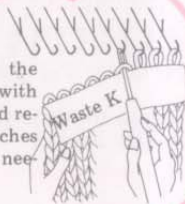

Ensure the stitches are securely in the hooks then remove the waste knitting.

When back and front stitches are on the main bed, change to waste yarn, knit a few rows and release after binding off

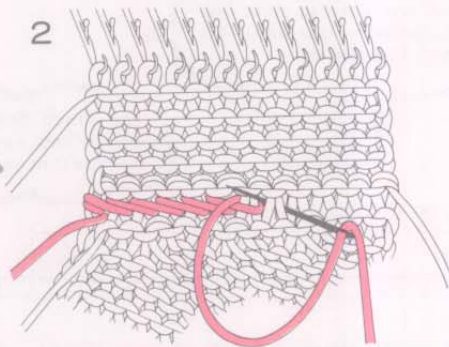

I've joined both shoulders, haven't I?



Perfect edge

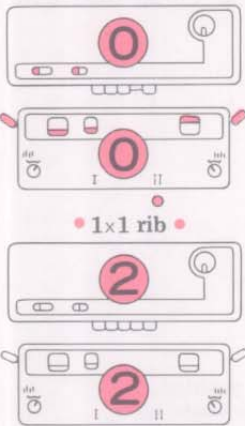

● Knitting the neckband ●

Place the Stitch Scale along the neck edge and read the number of stitches. Adjusting as necessary, arrange the needles as the diagram. Referring to the "finished edge by 1½ round circular knitting" on p. 29–30, work the finished edge by 2 rounds of circular knitting.

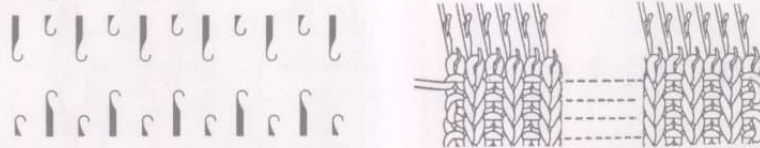

After ribbing transfer the stitches on the ribber to the main bed. Drop the ribber and remove the connecting arm, replace the sinker plate and prepare to attach the neckband to the front and back.

● Attaching the neckband to the Front and Back ●

With the wrong side of the garment facing you, pick up the stitches on each side and base of neck edge and place onto needles of neckband.

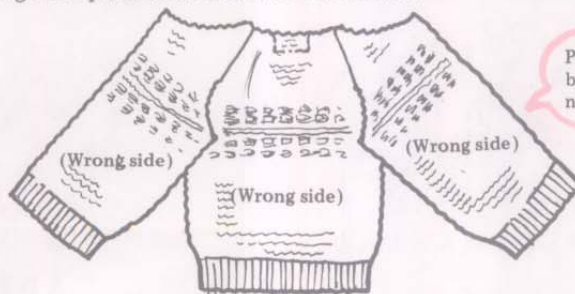

Pick up same number of stitches as neckband

② Pick up the stitches evenly along neck edge. Push the needles into E position.

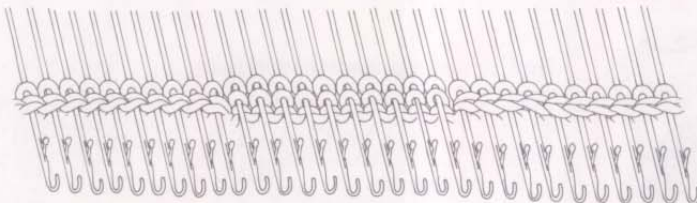

③ Knit 1 row from right side. Change to waste yarn and knit 2–3 rows of waste knitting. Bind off the stitches with a tapestry needle.

● Knit the buttonhole and button band ●

As you have to make buttonholes on one side, let's knit that side first.



The Stitch Scale may not be long enough to measure it in one go!



① Read the number of stitches on the Stitch Scale.

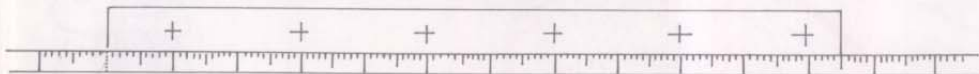

② Adjust the number you have read on the Scale to an odd number. Remember to keep the end needles on the main bed.

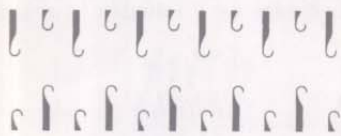

③ Cast on the stitches and finish the edge by 4 rows of circular knitting. Transfer the edge stitch on each side of main bed to the ribber as the ribber side is used as the right side.

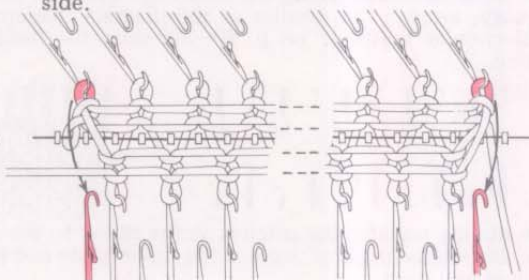

④ Set Slide Lever to I. Set the tension dial at 2/2 and knit up to the first buttonhole.

⑤ At the buttonhole position transfer the stitches as shown in the diagram below. Make all buttonholes in the same way.

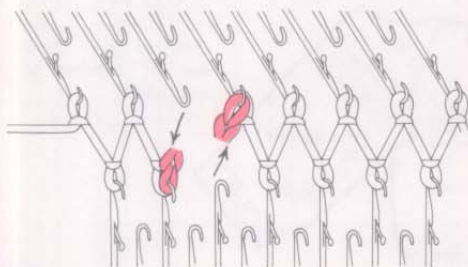

⑥ Leave the empty needles in B position. Knit to neckedge and change to waste knitting and remove from the machine.

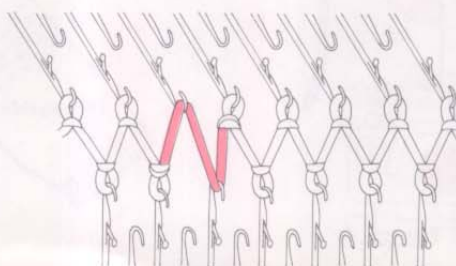



● Attach button bands to the Fronts ●

① Pick up the stitches along the button band edge and place onto needles.

With the wrong side of the garment facing you pick up the stitches evenly along centre front edge and place picked up stitches onto needles.

② Ensure that you pick up the stitches evenly.

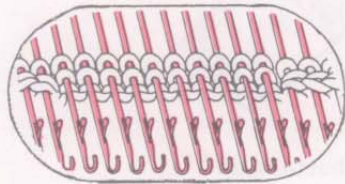
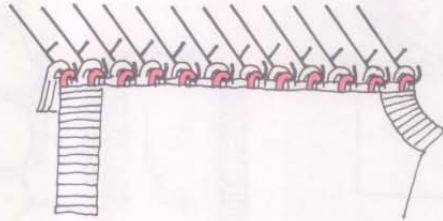
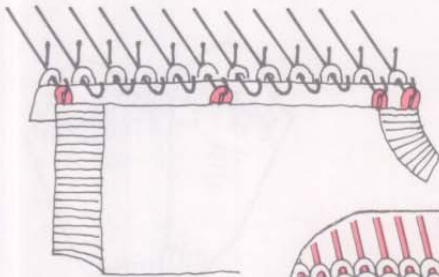

Let's bring forward the needles to E position.

③ Knit 1 row in main yarn. Change to waste yarn and knit a few rows, and Bind off the stitches.

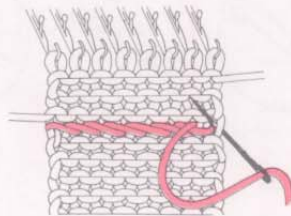
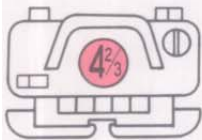

Attach the button band in the same way.



● Finishing the buttonholes ●

Using blanket stitch finish the buttonholes.

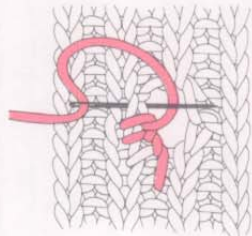

Place markers on button band for buttons. The wrong side of the garment looks like this.

Button position → ← Buttonhole

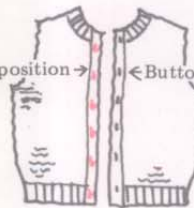



## 8: FINISHING



### ● Sew buttons on ●



Sew a button on each marked position

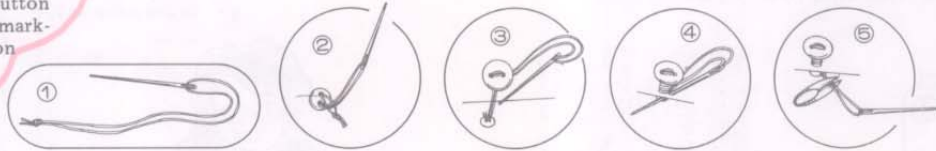

1. Thread a tapestry needle as illustrated.
2. Thread through button.
3. Attach to the button band.
4. Wrap the thread around the shank.
5. Fasten off securely.



You are wonderful! You did very well!



With the first one I just Hung on!  
With the 2nd one I've understood of knitting.  
With the 3rd one. I made it a present!



It's wonderful to make something by yourself!

You have done so well!

Next I want to tell you how to make different things from the same pattern.



Wow! I can design my own garments!

I wonder if I can make one in time for the concert!

# HOW TO MAKE VARIOUS GARMENTS FROM THE SAME PATTERN

Look at the applications!



## ① SHORT SLEEVE SWEATER

### MATERIALS:

Choose a fine yarn -- approx. 250g and approx. 350cm of ribbon for the shoulder and the sleeves.



### TENSION GAUGE (an example)

60 rows = 11.0cm



40 sts = 11.1cm

### HOW TO ADAPT THE PATTERN

- ① Extend the length to waistband.
- ② Shorten the sleeve and square off.

### PROGRAMME

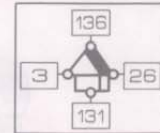

Pattern card page 136

### punchcard

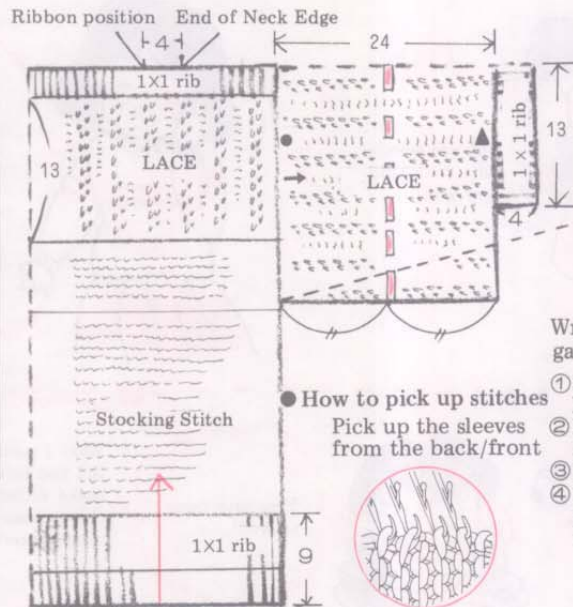
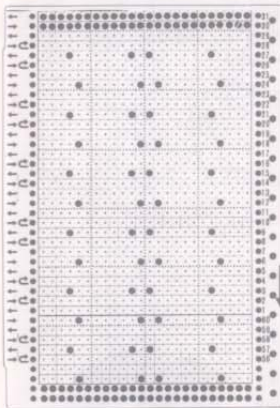

### How to pick up stitches

Pick up the sleeves from the back/front

### KNITTING POINTS

Wrong side of fabric is right side of garment.

- ① Knit the yoke and sleeves in lace.
- ② Pick up the sleeves from the back and front along armhole edge.
- ③ Decorate with ribbon.
- ④ After redrawing the pattern pieces work as the basic garments.

### ▲ How to knit the cuff

- ① Calculate the number of stitches to be decreased, push corresponding number of needles to D position.



- ③ Knit several rows with waste yarn and remove from machine.

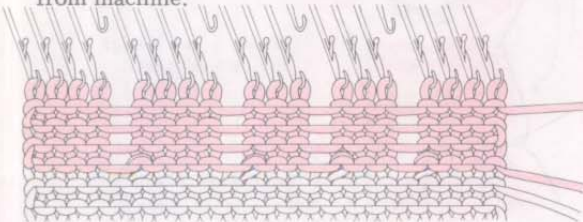

- ② By using the L-carriage, transfer the stitches.

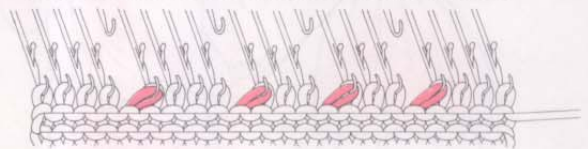

- ④ Knit the cuff in 1 x 1 rib. With the wrong side facing, replace the stitches of sleeve edge back onto same needles, knit 1 row and bind off.

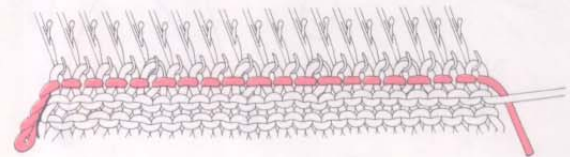

## ② OVERTOP

WORK THIS GARMENT ON THE GARTER CARRIAGE!

### MATERIALS:

3 ply --- approx. 400g

14 x 2cm buttons



### TENSION GAUGE (an example)

60 rows = 14.0cm



40 sts. = 15.6 cm



### punchcard

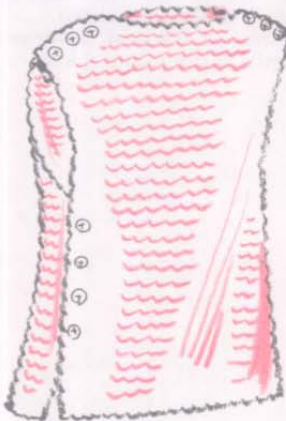

### HOW TO ADAPT THE PATTERN

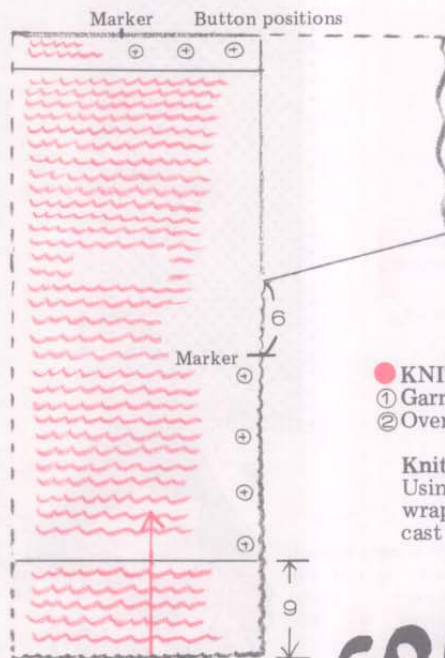

### PROGRAMME

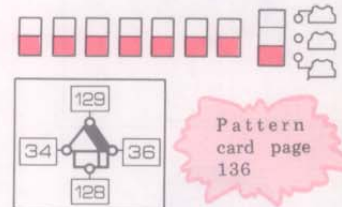

Pattern card page 136

### KNITTING POINTS

- ① Garment is worked in Garter stitch pattern.
- ② Overlap the shoulders and attach buttons.

### Knitting the belt:

Using main yarn cast on 18 stitches by 'e' wrap method, knit approx. 500 rows and cast off.

### How to fit the shoulders

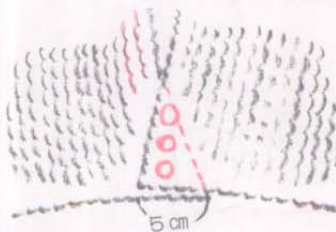

# ① A-LINE SKIRT



## MATERIALS:

Using a very fine yarn for the backing approx. 200g and a heavier yarn approx. 150g for the weaving.



60 rows = 11.2cm

## TENSION GAUGE (an example)



40 sts = 13.1cm

## PUNCHCARD

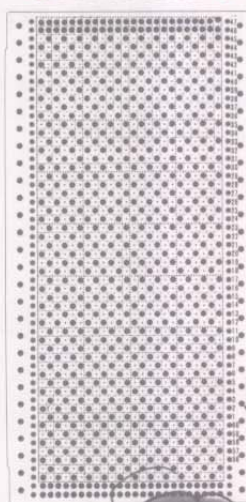

## PROGRAMME

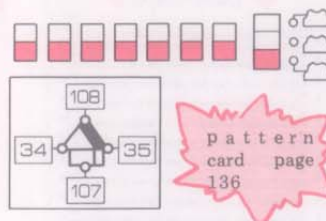

The stitch design is a 1 x 1 weaving pattern.

It is very important to use different weight yarns for this stitch.



## KNITTING POINTS

Work in weaving stitch.

- ① The inside hem is worked in stocking stitch only.
- ② The facing of the belt is knitted in stocking stitch.
- ③ The rest of the skirt is worked exactly as the A-line skirt.

## WEAVING PATTERNS

- ① Knit the inside hem, ending with the carriage on the left. Insert the card and lock on row 1. Set card lock lever to ●. Set change knob to KC and knit 1 row. Set weaving brushes to working position. Set card lock lever to ▼.
- ② Set the weaving yarn to the left weaving yarn guide. Holding the end of the weaving yarn, operate the carriage to the left.
- ③ Transfer the weaving yarn under the K-carriage to the right Weaving Yarn Guide.

- ④ Ensure that the weaving yarn is securely in the Weaving Yarn Guide when operating the K-carriage. The yarn must be placed in the right Weaving Yarn Guide when the carriage is moved from left to right and vice versa.

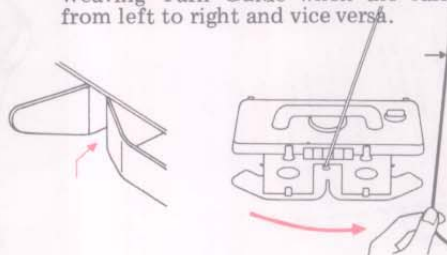

## ② LACE SKIRT WITH GATHERED WAIST

### MATERIALS:

You will need approx. 350g of a very fine yarn.



### TENSION GAUGE (an example)

60 rows = 11.3 cm



40 sts = 11.6 cm



### PUNCHCARD

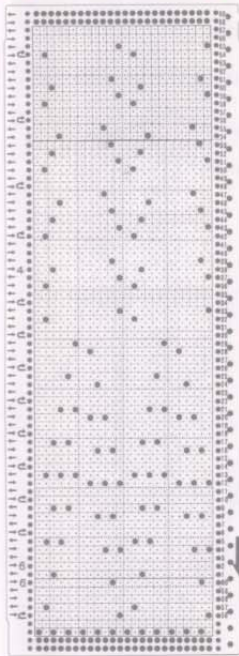

### HOW TO ADAPT THE PATTERN

- ① Redraw the side seam as illustrated.
- ② Knit 3 pieces to make up the skirt.

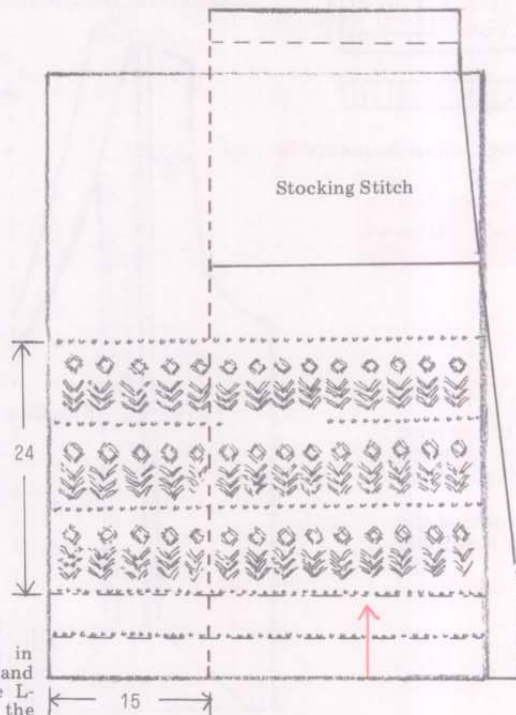

### Reading the arrows



knit 2 rows in stocking stitch and then move the L-carriage to the right.  
 ← } move the L-carriage  
 → }  
 6 rows of stocking stitch and then move the L-carriage to the right.

Pattern card page 136

### PROGRAMME

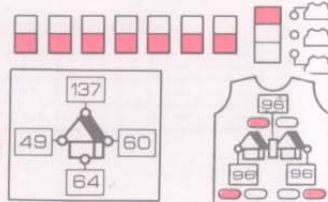

### KNITTING POINTS

① Knit 3 pattern repeats at the hem of the skirt. The width should be adjusted so the number of needles used are in multiples of 12 (1 pattern repeat) + 2 stitches for the seam allowance.

② Knit to the waistline and waste knit. Replace the stitches decreasing along the row by placing 2 stitches on each needle. Knit the waistband.

Set the card to row 1 and lock the Card Lock Lever to ● Using the 1 × 1 needle pusher and the L-carriage make a picot hem by, knitting to the fold and then making picot edge, knit the same amount of rows as before transferring stitches.

### Working the Hem

caston in waste knitting, and knit a few rows. Change to main yarn and at one full tension tighter knit to picot edge. Work picot edge as above.

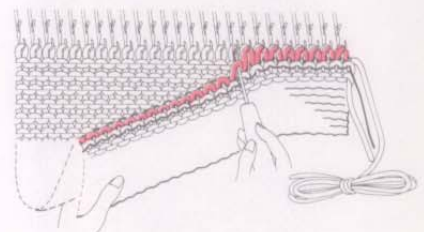

# ① MAN'S V-NECK SLIPOVER



## MATERIALS:

4 ply Main yarn	200g	
First Contrast Colour	50g	
Second Contrast Colour	50g	60 rows = 16.5cm



## TENSION GAUGE (an example)

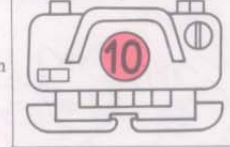

40 sts = 13.4cm

### Back Neckband

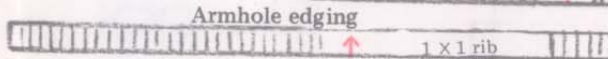
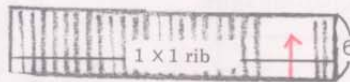
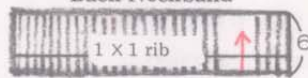

### Neckband Colour Sequence

Con Col 1	5 rows
Con Col 2	5 rows
Main Yarn	5 rows
Con Col 1	5 rows
Con Col 2	5 rows

### Edging Colour Sequence

Con Col 2	2 rows
Main yarn	12 rows

### KNITTING POINTS

- Following the knitting symbols work the reverse stitches using the latchet tool. When the garment is complete catch every 5cm to give a cabled effect.
- The neckband is knitted in 1 x 1 rib working the colours as given. The rest of the garment is worked as the V-neck slipover.

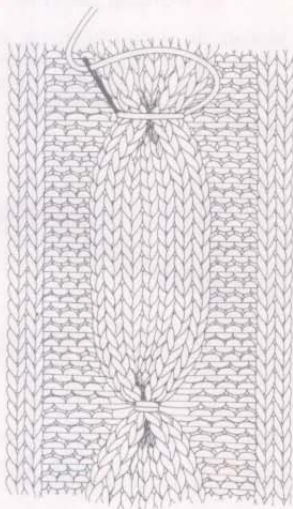

### HOW TO ADAPT THE PATTERN

- Draw in the new neckline.
- Make a wider neckband.
- Reverse the stitches using the latchet tool.

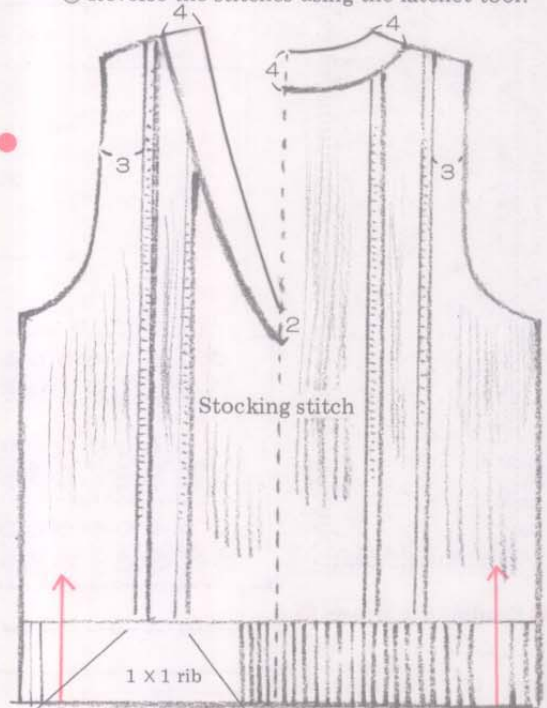

### Knitting symbols

—	—									—	—
—	—									—	—
—	—									—	—

Catch every 20th row to give a cabled effect.



## ② LADY'S V-NECK SLIPOVER

WORK THIS GARMENT ON THE GARTER CARRIAGE!

### MATERIALS:

Medium weight yarn — 200g



### TENSION GAUGE (an example)

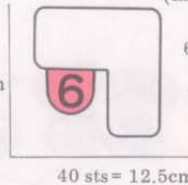

60 rows = 14.7cm

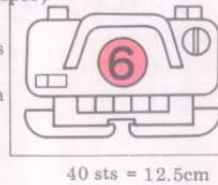

### HOW TO ADAPT THE PATTERN

- Draw the separating line onto the pattern piece, opening it out to make the armhole longer.

Front neckband (2 pieces)

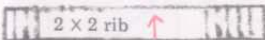

Back neckband

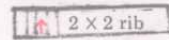

Armhole edging

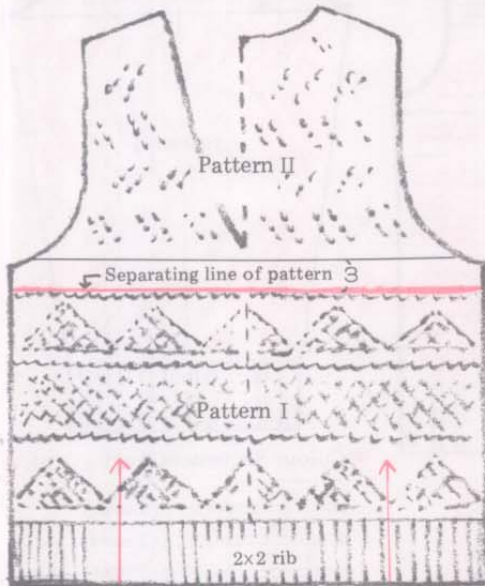
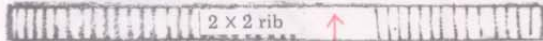

### PUNCHCARDS

PATTERN I

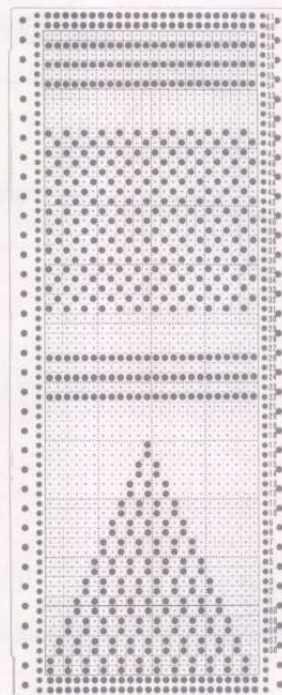

PATTERN II

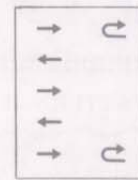
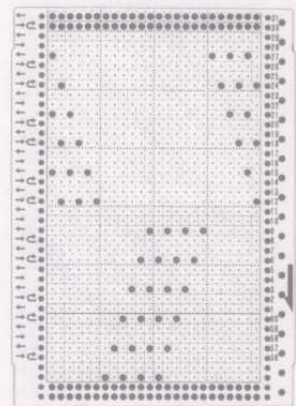

Direction of L-carriage

Direction of K-carriage

### KNITTING POINTS

- Knit the waist rib in 2 x 2 rib.
- The garter stitch pattern is worked using the Garter carriage.
- From the armhole a fine lace stitch is worked using the L-carriage.
- The neckband and armhole edging are in 2 x 2 rib. To remind you of how this is done refer to Step 4 and Step 5, the rest of the garment is worked as for V-neck is slipover.

### PROGRAMME

PATTERN I



PATTERN II

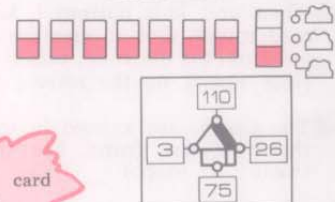

pattern card page 136

# ① LADY'S SET-IN SLEEVE SWEATER



### MATERIALS:

4 ply Main Colour	200g
Con Col 1	100g
Con Col 2	100g
Con Col 3	100g



### ● TENSION GAUGE ● (an example)

60 rows  
=  
16.2 cm



40 sts = 13.3 cm

### ● PUNCHCARDS ●

#### PATTERN I

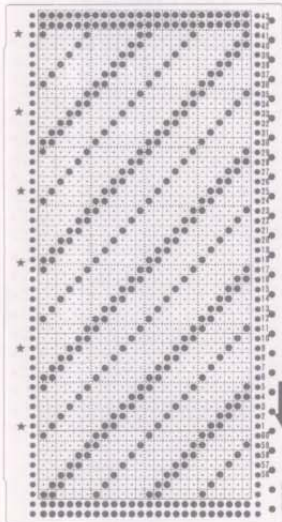

#### PATTERN II

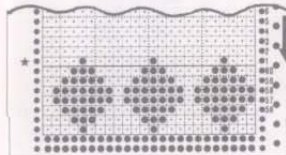

### ● HOW TO ADAPT THE PATTERN ●

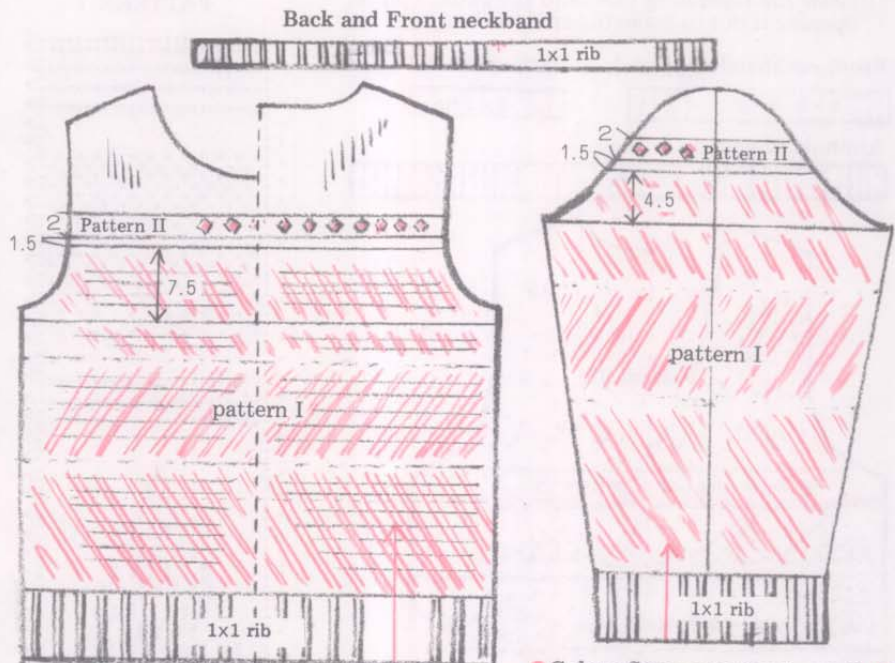

### ● Colour Sequences for 1 x 1 rib ●

8 rows	→ Col 1 (2 rows)
8 rows	→ Col 2 (2 rows)
8 rows	→ Col 3 (2 rows)
8 rows	→ Col 3 (2 rows)

### ● KNITTING POINTS ●

- ① The waistband, neckband and cuffs are knitted in 1 x 1 rib. For reference see Step 3.
- ② When you knit pattern I, knit 1 complete card round, then reverse the card, — take it out from the machine, turn it back to front. Note row 1 on the reverse side.
- ③ The sleeves are knitted in the same way as the back and front. For the rest of the sweater see Step 4.
- ④ Change the colours on pattern I as indicated down the side of the card.

For the 2nd pattern this side is above. For the 3rd pattern this comes to bottom.

### ● PROGRAMME ●

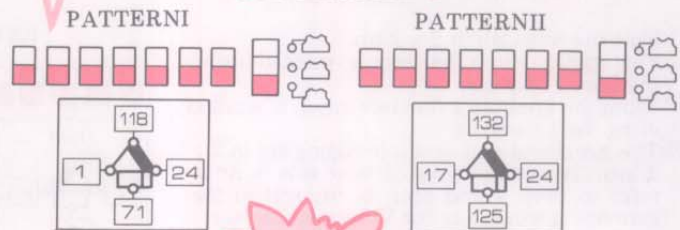

pattern card see page 136.

## ② LADY'S SET-IN SLEEVE SWEATER

### MATERIALS:

Main yarn 200g  
 Contrast colour 150g

60 rows = 12.3cm



### TENSION GAUGE (an example)



40 sts = 12.3cm



### PUNCHCARD

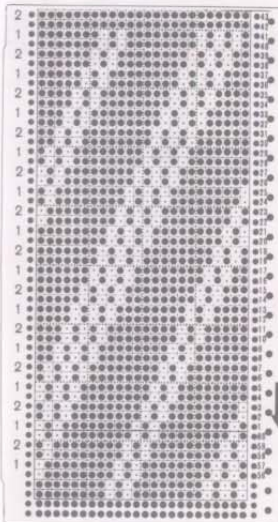

### HOW TO ADAPT THE PATTERN

Extend the neckband by 5.5cm.

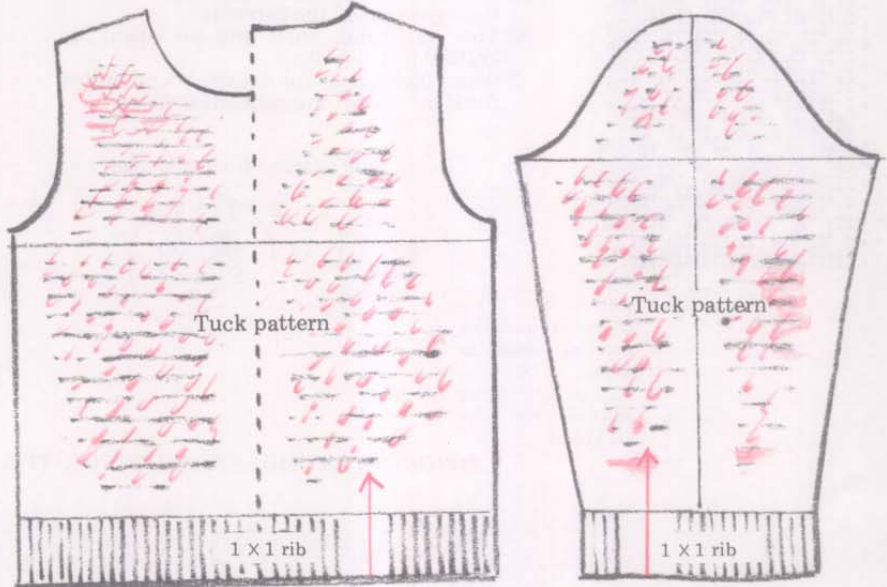
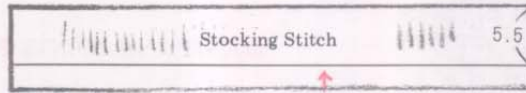

### PROGRAMME

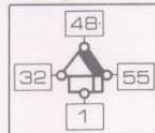

### KNITTING POINTS

- ① This garment is knitted in 2 colour tuck stitch
- ② The waistband and cuffs are knitted in 1 x 1 rib.
- ③ The collar is in stocking stitch then left to roll naturally.  
The rest of the garment is as Step 4.

pattern card  
 see page 136.

# ① MAN'S RAGLAN SWEATER



## MATERIALS:

Medium thickness yarn 450g



## TENSION GAUGE (an example)

60 rows = 11.3 cm



40 sts = 13.3 cm

## PUNCHCARD

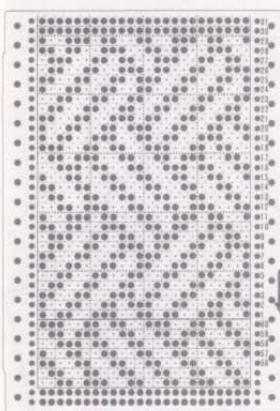

## HOW TO ADAPT THE PATTERN

Use the pattern without any changes.

## KNITTING POINTS

- ① The wrong side of the knitting is used as the right side of the garment.
- ② The waistband, cuffs and neckband are knitted in 1 x 1 rib.
- ③ When picking up for the neckband ensure the right side of the garment is facing.

## PROGRAMME

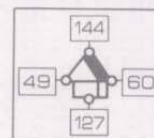

Pattern card page 137.

## Decreasing stitches for neck edge

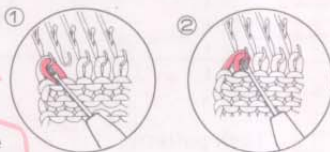

If you decrease the neckline stitch as shown it will be easy to pick up the stitches for the neckband.

## PICKING UP THE STITCHES FOR THE NECKBAND

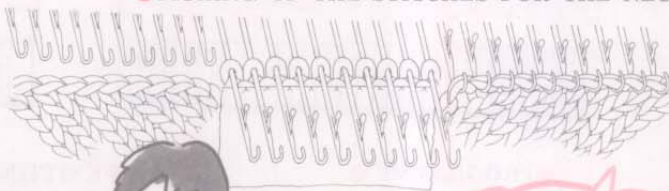

Using a transfer tool pick up the stitches for the neckband and place onto needles.



## ② RAGLAN SWEATER WITH SINGLE MOTIF

### MATERIALS

4 ply Main Yarn	150g
Con Col 1	50g
Con Col 2	50g
Con Col 3	50g



### TENSION GAUGE

60 rows  
=  
14.2cm



40 sts = 12.4cm



### PUNCHCARDS

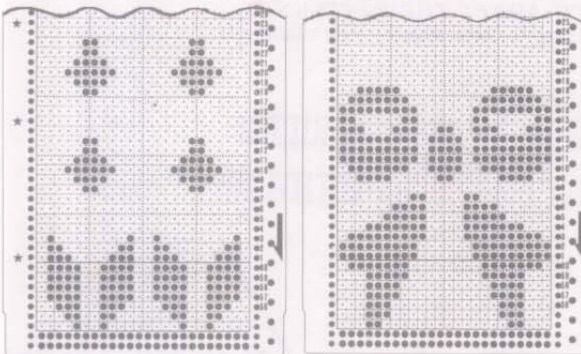

### KNITTING POINTS

- ① The garment is knitted in fairisle and has a single motif.
- ② Waistband, neckband and cuffs are knitted in 1 x 1 rib. Refer to Step 3.
- ③ The rest of the garment is worked as for Step 5.

### HOW THE SINGLE MOTIF FINISHING YARN IS MADE

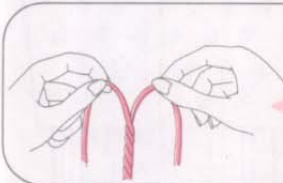

Cut approx. 40cm of main yarn, divide it into two as shown here.

Using the one-point cam (Refer to Manual).



### TO WORK SINGLE MOTIF

Insert card and lock on row 1. Set change knob to SM. Knit 1 row and the needles are selected. Push the MC button and place the contrast colour in Yarn Feeder B. Set Card Lock Lever to ▼ knit 1 row. Bring forward to D position the second needle from the end of selected needle on the K-carriage side and put the finishing yarn into its' hook. Then push the needle to B position. Move the carriage from left to right and place the finishing yarn in exactly the same way as the left side.

For programme and pattern card refer to page 137

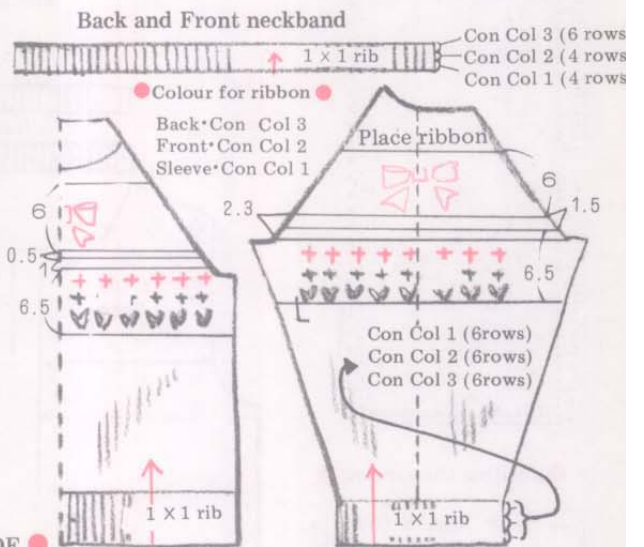

Open the raglan so the underarm drops but leave the rest of the garment as it is.

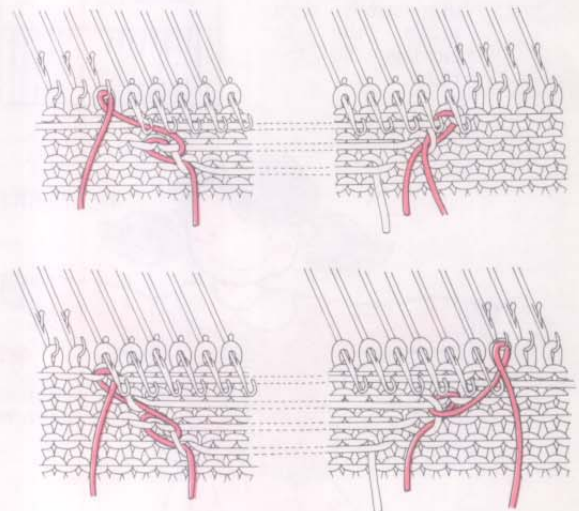

# ① LADY'S CARDIGAN



**MATERIALS:**  
 4-ply — approx 300g  
 5 x 1.8cm buttons.



60 rows =  
 15.0cm

## ● TENSION GAUGE ●

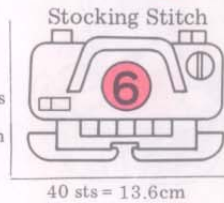

40 sts = 13.6cm



40 sts = 13.6cm

## ● PUNCHCARD ●

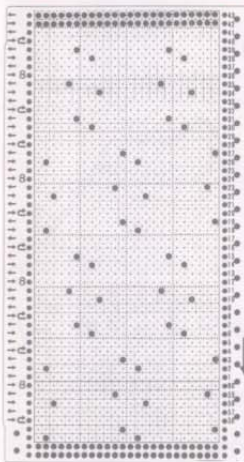

## ● HOW TO ADAPT THE PATTERN ●

The pattern is used without any changes.

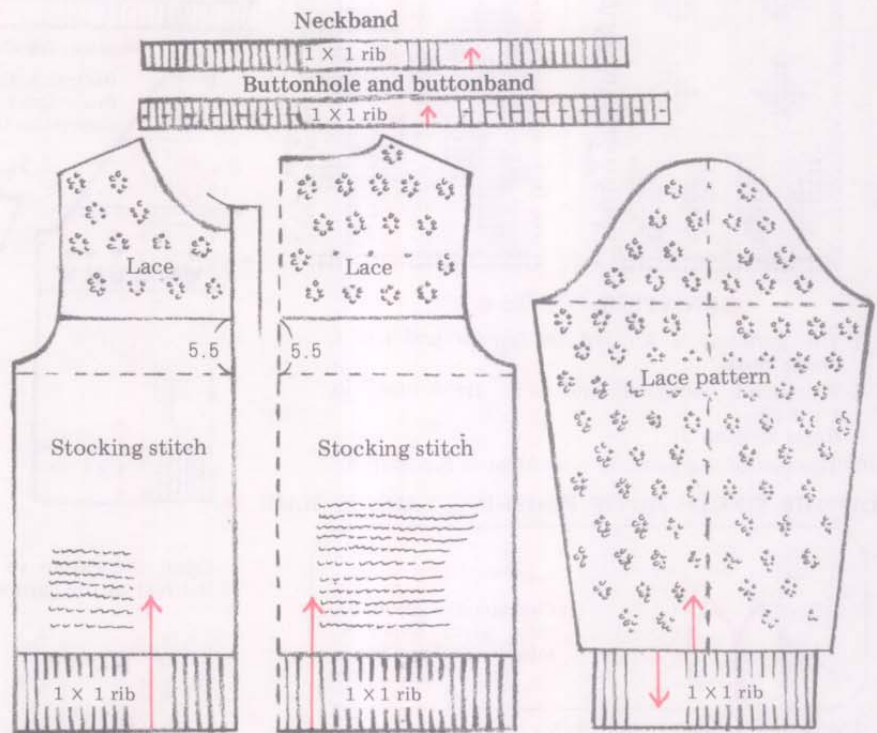

## ● Reading the arrows ●

→ 8 = knit 8 rows in stocking stitch, then move the L-carriage to the right.  
 ← = knit 8 rows in stocking stitch, then move the L-carriage to the left.  
 → ↻ = 2 rows of stocking stitch then move the L-carriage to the right.



## ● KNITTING POINTS ●

① Remember to attach the extension rails when knitting lace.

## ● PROGRAMME ●

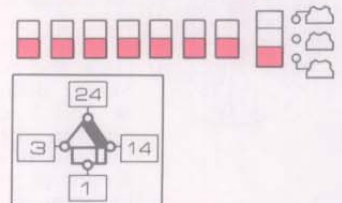

Pattern card see page 13.

## ② LADY'S CARDIGAN

WORK THIS GARMENT ON THE GARTER CARRIAGE!

### MATERIALS:

4 ply — approx 450g  
5 x 2.3cm buttons.



### TENSION GAUGE (an example)

60 rows  
=  
16.2 cm



40 sts = 14.6 cm



### PUNCHCARD PATTERN I

Stitch I

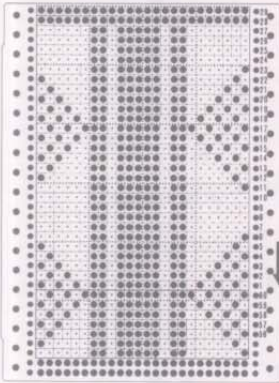

### HOW TO ADAPT THE PATTERN

- ① Extend the garment length.
- ② Mark the line of change of stitch.
- ③ Extend the cuffs and hems.

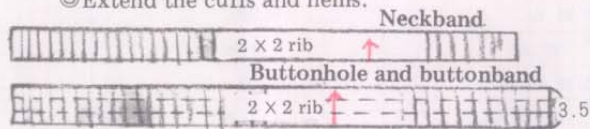

### PUNCHCARD PATTERN II

Stitch II

★ Set card at row 60 and lock.

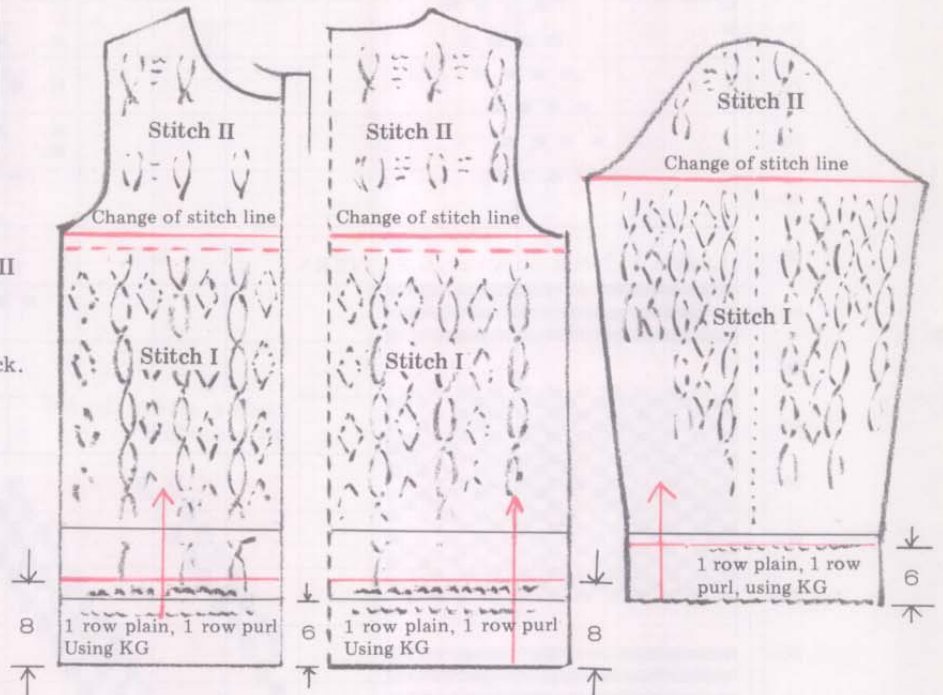

### KNITTING POINTS

- ① From the hem to armhole shaping use stitch I.
- ② For the yoke and sleeve head use stitch II.
- ③ For the cabled effect, pick up 1 stitch on each side of the vertical design every 4.5cm and using a separate piece of yarn tie into a knot.
- ④ The buttonhole and buttonband and the neckband are knitted in 2 x 2 rib.
- ⑤ The side seams on the garter stitch pattern are left open. The rest of the garment is worked in exactly the same way as the Basic Cardigan.

### PROGRAMME

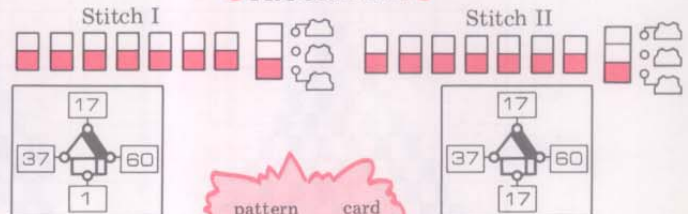

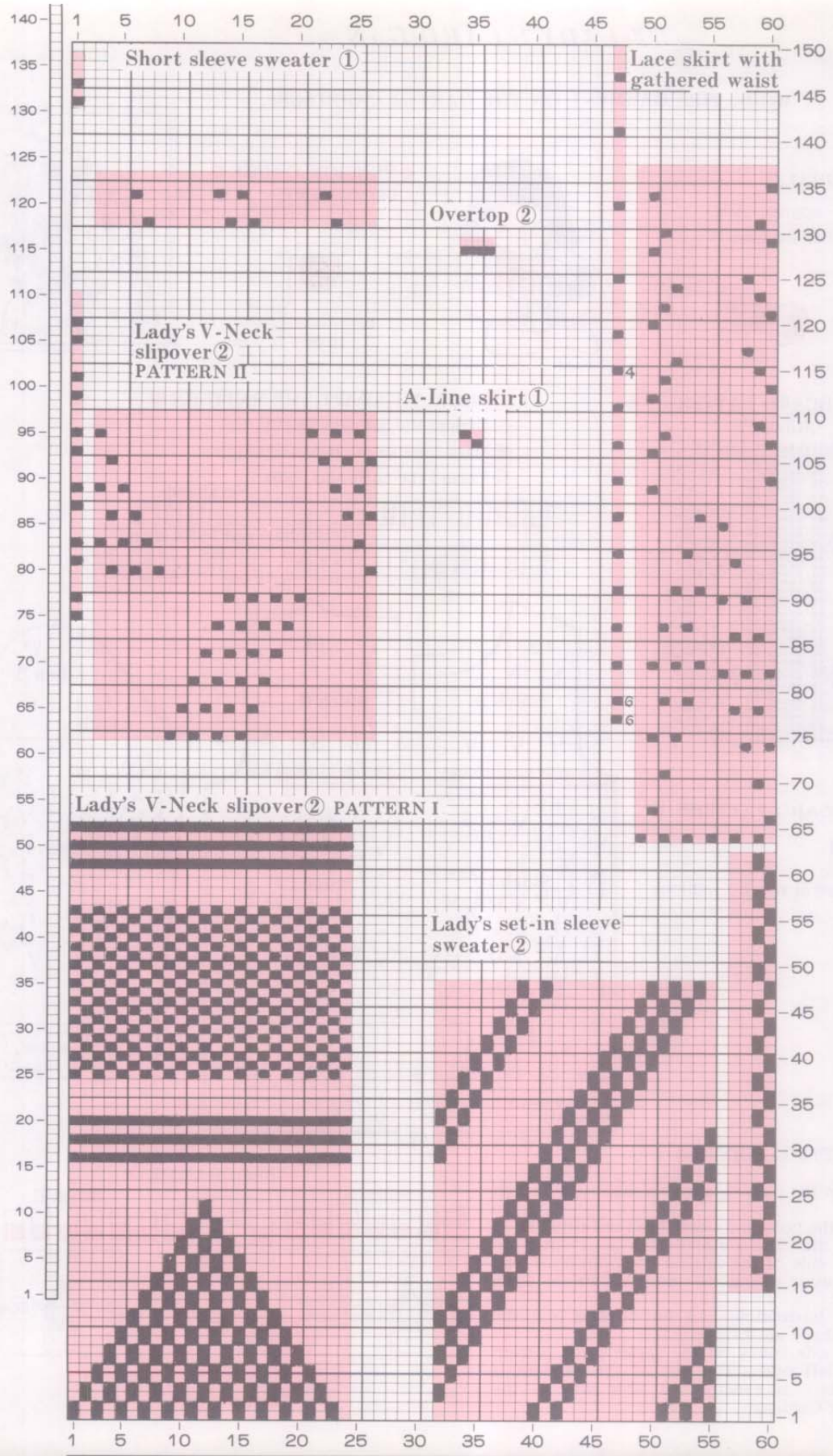



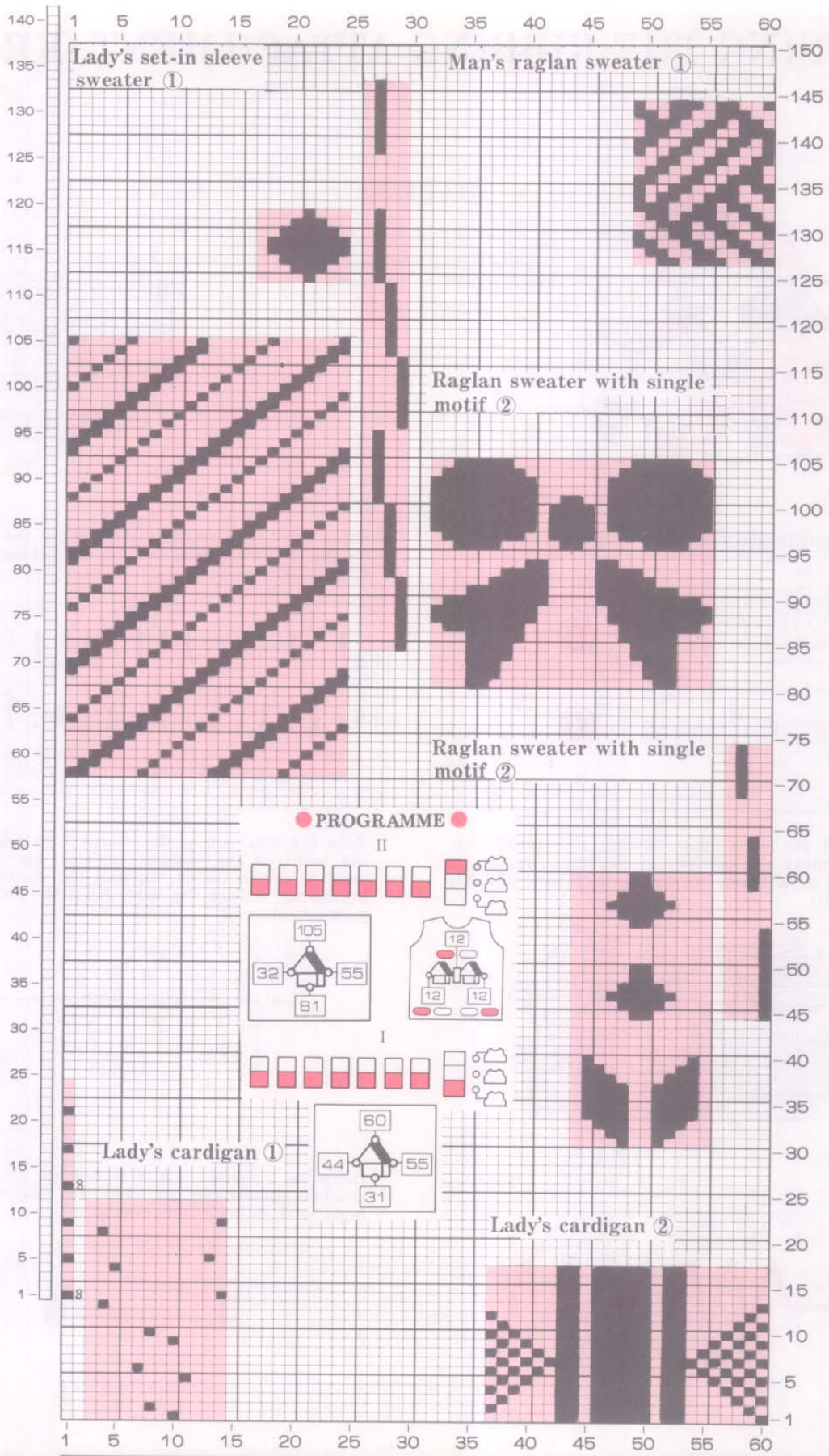

# USING THE RIBBING ATTACHMENT (KR)

## ● 1×1 RIB ●



Referring to the instruction manual, let's set up the ribber

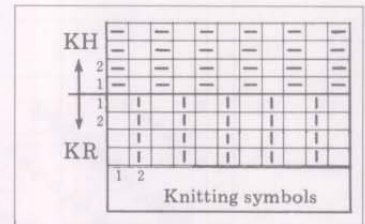

① Following the diagram below set the KH and KR.

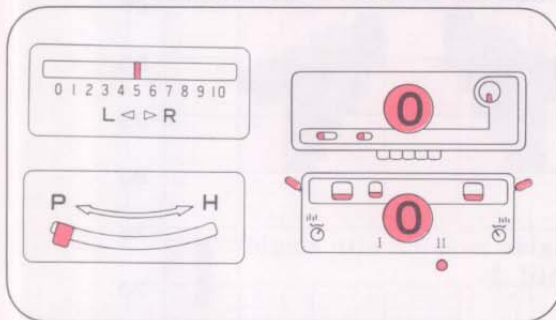

② Using the 1 × 1 needle pusher, place the needles on the KH (main bed) and the KR (ribber) as the diagram below.

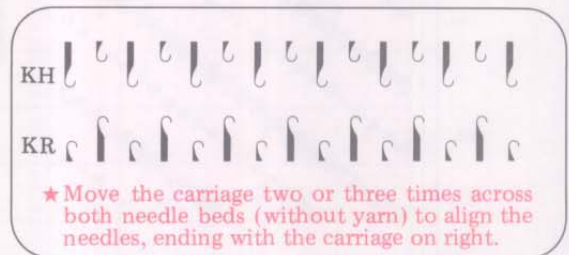

③ Thread the yarn and holding the end of the yarn, move the carriage to the left. The yarn is caught on alternate needles on both beds (the KH and KR).

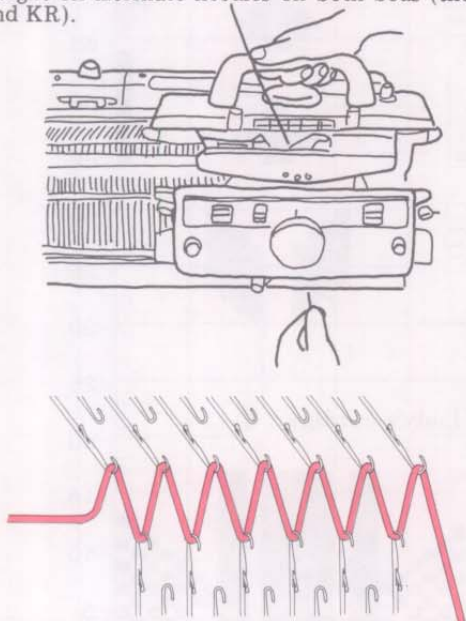

④ Take the wire out of the Caston comb and push the teeth of the caston comb up between the yarn, as shown below. Keeping the caston comb horizontal, replace the wire. Place the end of the yarn into the clip.

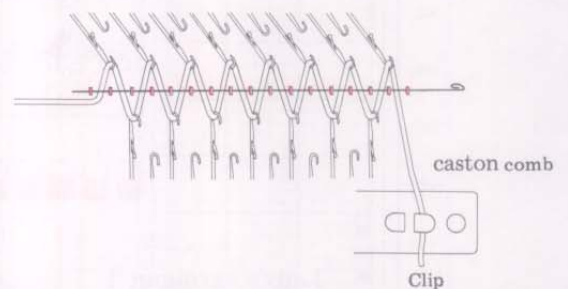

⑤ Hang the weights, — 2 large weights for 50~100 stitches. Remember to keep the caston comb horizontal, so hang them evenly.



It's an accessory and comes with the ribber!



⑥ Set the KH and KR as shown below.

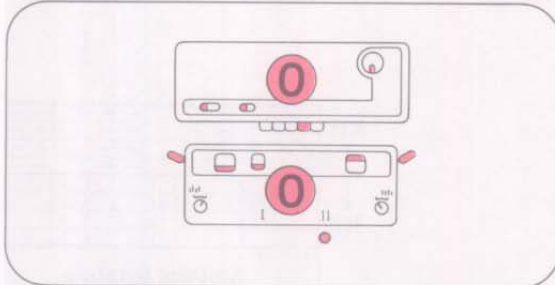

⑦ Move the carriage to the right, the KH knits.

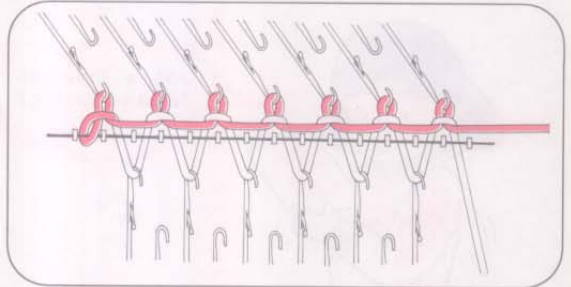

⑧ Move the carriage to the left, the KR knits.

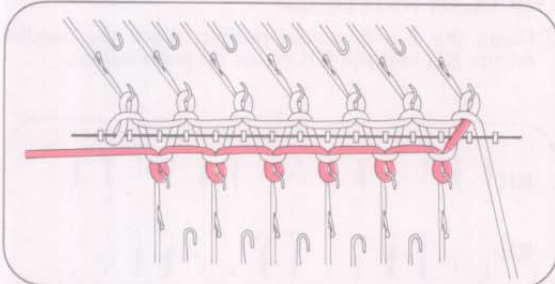

⑨ Move the carriage to the right, the KH knits. You have now completed a finished edge by circular knitting.

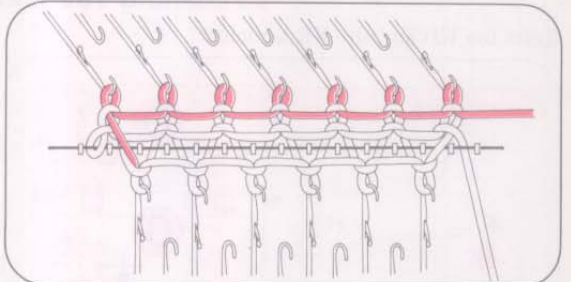

★ If you want to use the ribber (KR) side as the right side, make 2 rounds of circular knitting!

#### HOW TO KNIT 1 x 1 RIB

Set the carriage as shown below. NOTE: Never try to return the carriage from the middle of a row, ensure that the carriage clears all the needles before you try to return it.

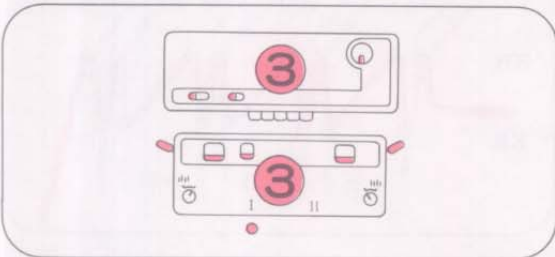

When you have completed the rib and you want to continue in a stitch using the KH, transfer the stitches using the transfer needle.

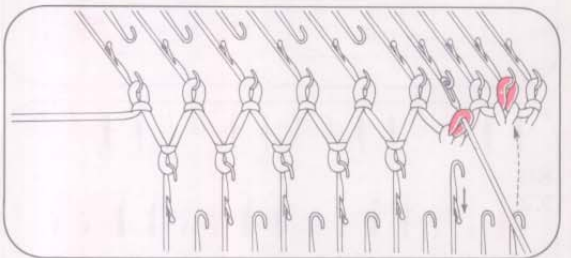

The ribber does a great job.

If you have a Transfer carriage you can transfer the stitches very quickly!



● 2×2 RIB ●



Just a little different to the 1 × 1 rib.

KH	—	—	—	—	—	—	—	—	—	—	—	—	—	—	—	—	—	—	—
↑	2	—	—	—	—	—	—	—	—	—	—	—	—	—	—	—	—	—	—
1	—	—	—	—	—	—	—	—	—	—	—	—	—	—	—	—	—	—	—
↓	1	—	—	—	—	—	—	—	—	—	—	—	—	—	—	—	—	—	—
2	—	—	—	—	—	—	—	—	—	—	—	—	—	—	—	—	—	—	—
KR	—	—	—	—	—	—	—	—	—	—	—	—	—	—	—	—	—	—	—
	1	2	3	4															

Knitting Symbols

● FINISHING THE EDGE BY CIRCULAR KNITTING ●

① Set the KH and the KR as below.

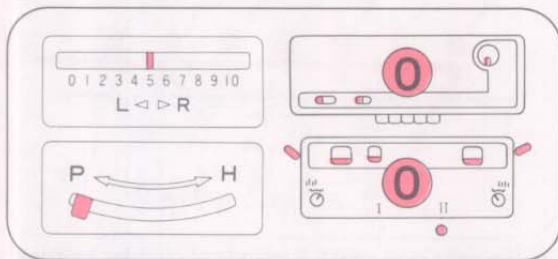

② Using the 2 × 2 needle pusher, place the needles on the KH and the KR as the diagram below.

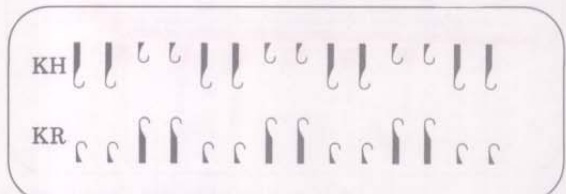

③ Set the Half Pitch Lever to H so that the first row will be cast on as under 4.

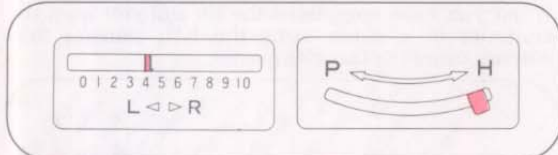

④ Thread the yarn feeder (refer to 1 × 1 rib) and move the carriage to the left. The yarn is caught as below.

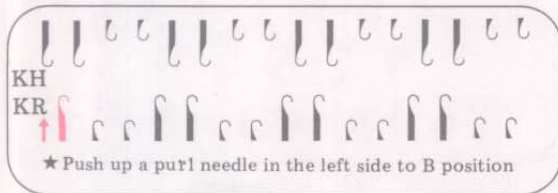
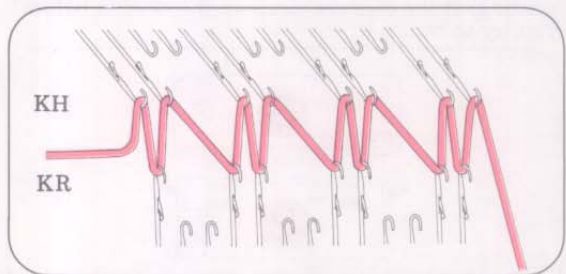

⑤ Take the wire out of the caston comb and push the teeth of the caston comb up between the yarn as shown below. Keeping the caston comb horizontal, replace the wire. Place the end of the yarn into the clip.

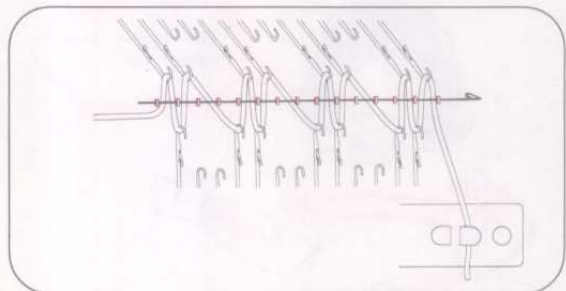

⑥ Hang the weights, = 2 large weights for 50-100 stitches. Remember to keep the caston. comb horizontal, so hang them evenly.

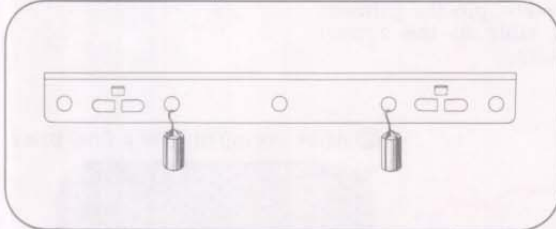

⑧ Move the carriage to the right, the KH knits.

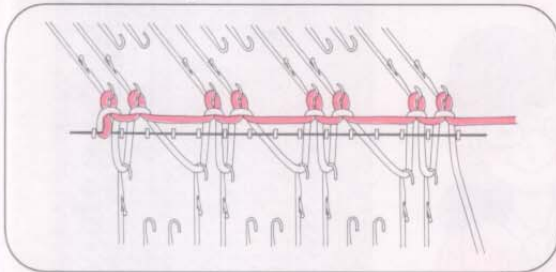

⑩ Move the carriage to the right, the KH knits.

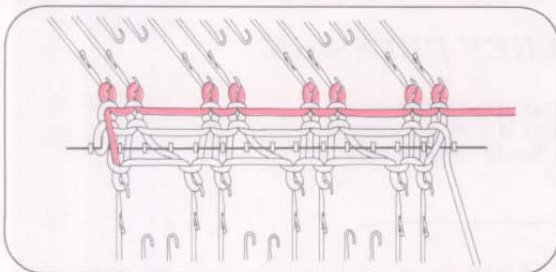

★ After transferring the stitch push the empty needle to A position.

● HOW TO KNIT 2 x 2 RIB ●

Set the carriage as below and knit the desired number of rows.

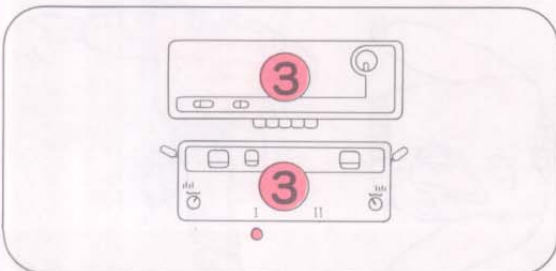

⑦ Set the KH and KR as shown below.

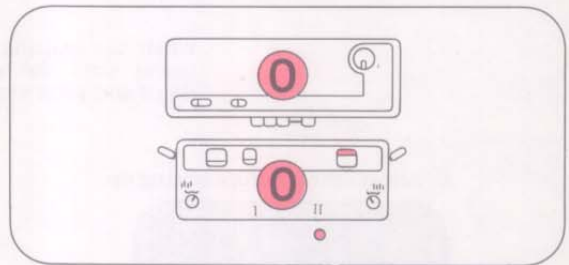

⑨ Move the carriage to the left the KR knits.

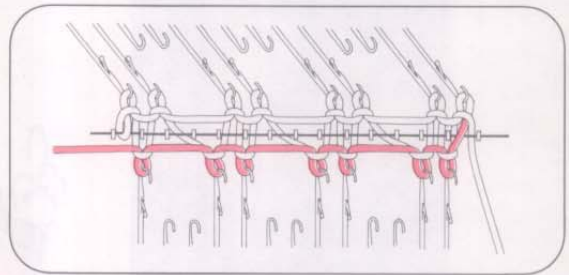

⑪ Set the Half Pitch Lever to P.

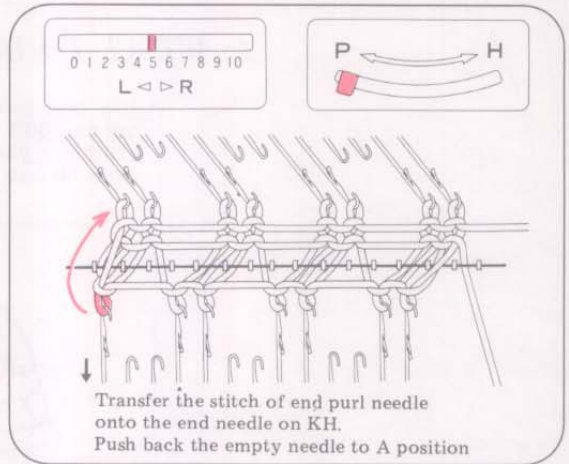

If you want to use the ribber (KR) side as the right side make 2 rounds of circular knitting.

# PRESSING

When the knitting is complete, pin the garment pieces onto the pressing table to the correct shape and press very carefully.

① Always press before sewing up.



② After sewing up give a final press.

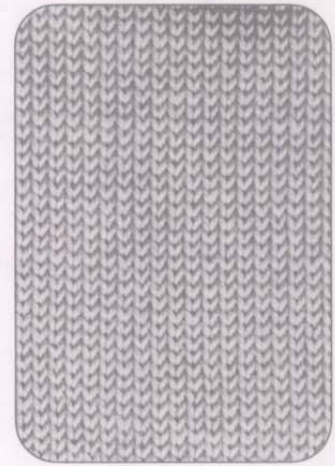

Press very carefully



## 1: WHAT TO USE WHEN PRESSING

① It is best to use a steam iron when working in 100% wool, but if you are using a synthetic yarn, read the label for instructions on how to press.

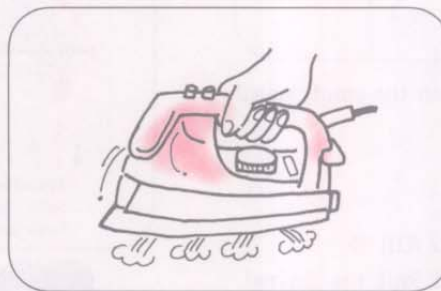

② Pressing

Use a pressing table for flat pieces.

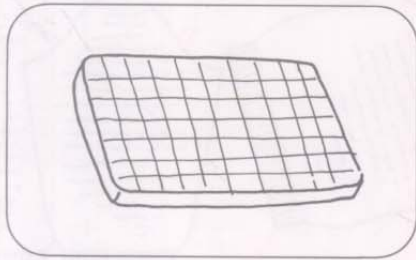

Use a sleeve board for seams.

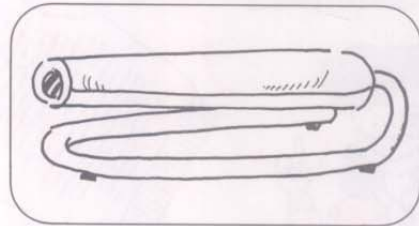

③ Binding wire and blocking pins

**BINDING WIRE**

Use the binding wire either by threading along the edge stitches or by winding method.

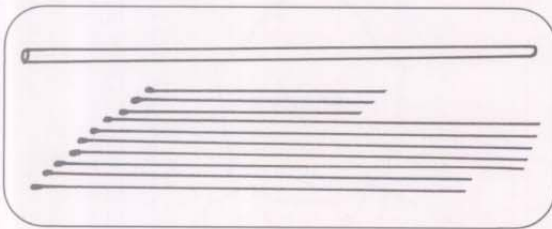

**BLOCKING PINS**

Blocking pins are used to pin the edges of the garment pieces.

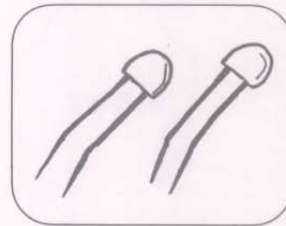

**2: CHOOSE THE CORRECT TEMPERATURE FOR THE YARN BEING USED**

Type of Fibre	Approx temperature
Linen	180°–190°C
Wool	160°–180°C
Silk	140°–170°C
Rayon, polyester nylon and acrylic	130°–170°C

Let's be careful!



### 3: HOW TO PRESS A SWEATER

① Always press your garments before sewing



#### ● BACK AND FRONT AND SLEEVES ●

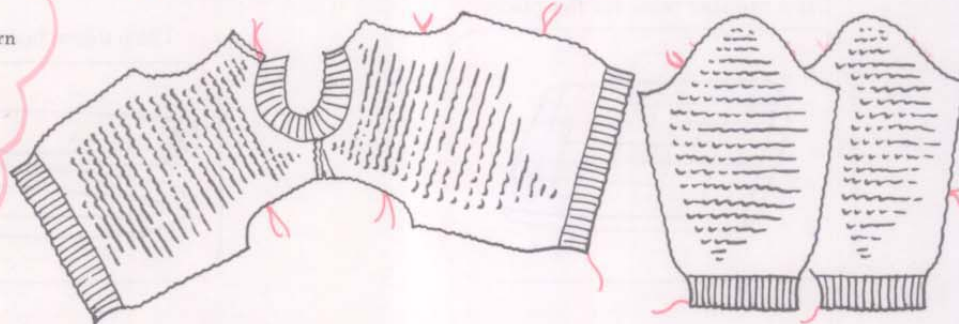

① Trace the pattern pieces you have knitted onto another piece of paper.

② Spread the marked paper onto the pressing table.

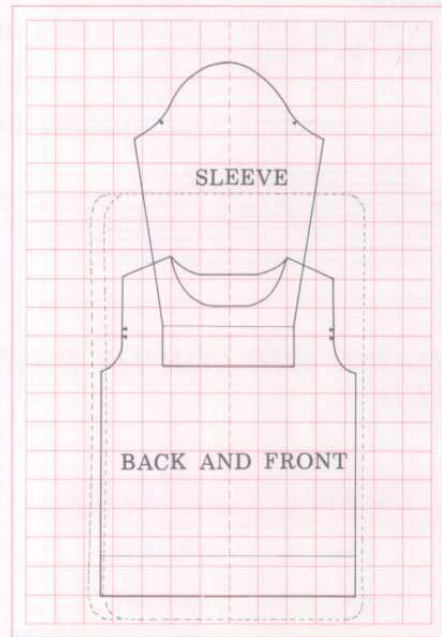
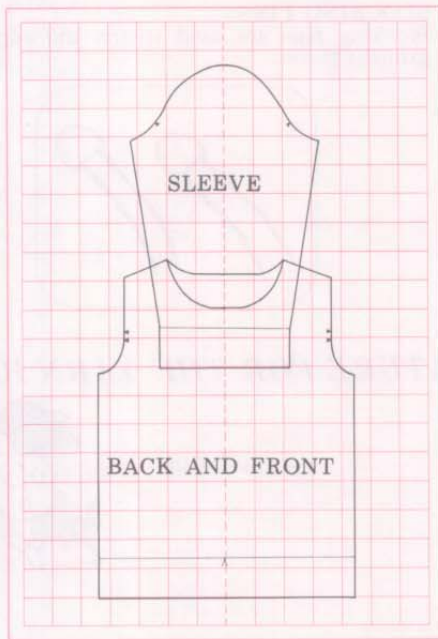

#### ● PRESSING THE BACK AND FRONT ●

Binding wire using the winding method..

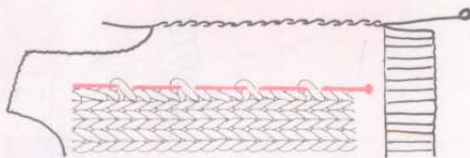

Binding wire threading through.

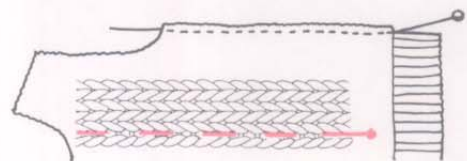



② Pin each pattern piece out to the correct shape.

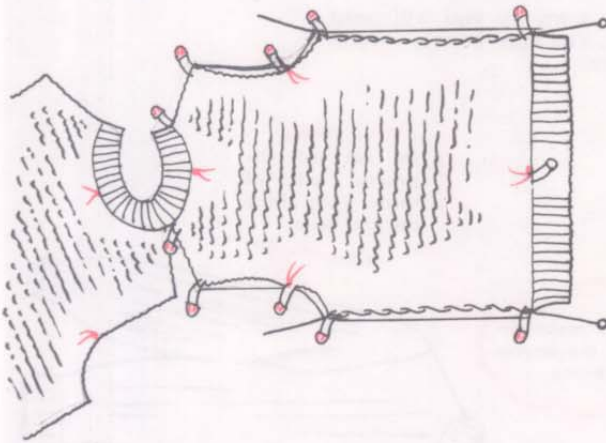

③ You will need more pins along the curved edges.

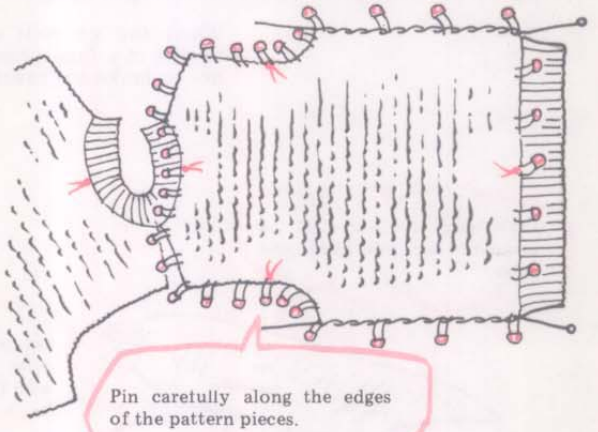

④ Ensure that when you press the garment pieces the knitted stitches are straight.

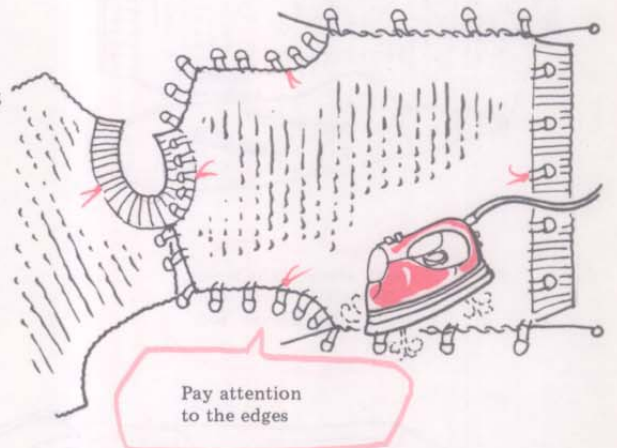
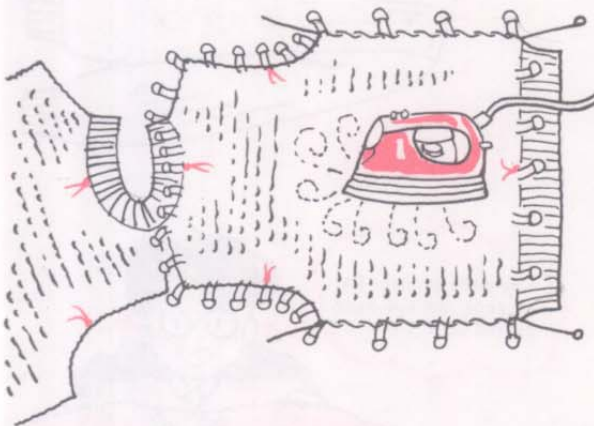

⑤ Do not press the ribbed part.

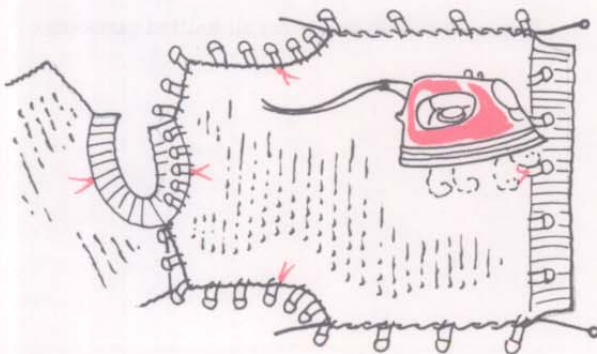

⑥ Press sleeves as Back and Front.

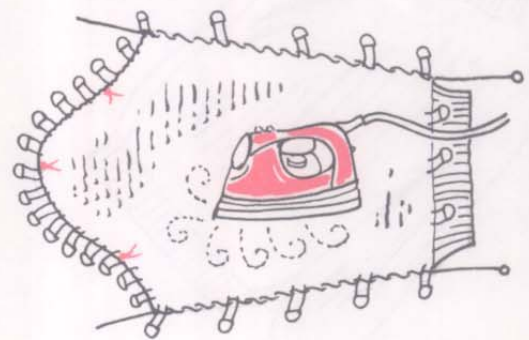

## ② Final pressing

When the garment is sewn up you will need to give it a final press. You must be very careful not to make any creases.

Let's open the seams of the underarm and side seams and press

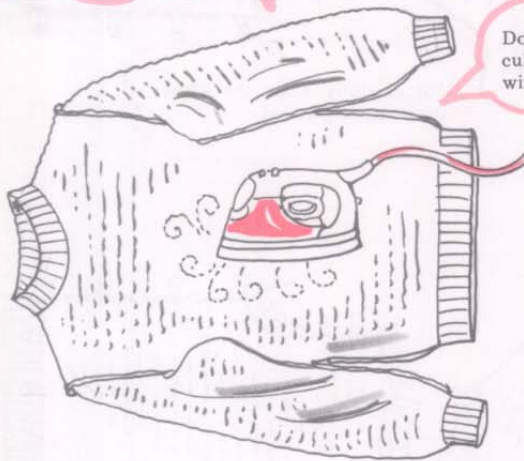

Do not make circular movements with the iron

Do not pull the garment out of shape when giving the final press.

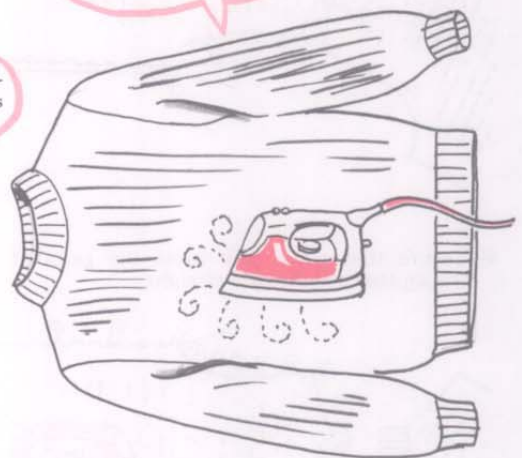

Press seams lightly do not stretch them and make the sleeves too long.

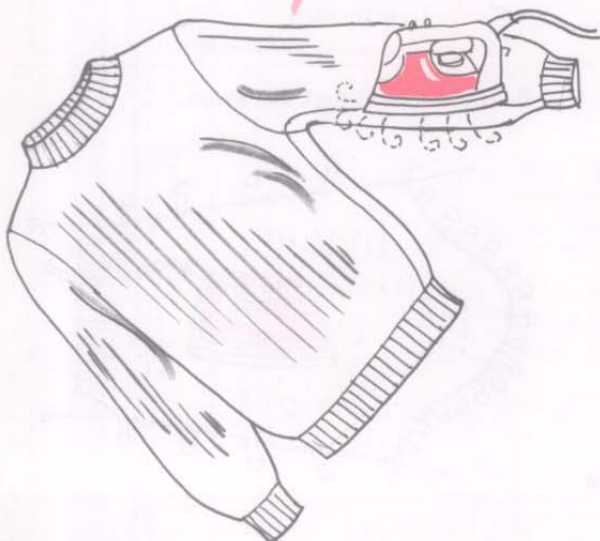

Leave the garment flat to cool, do not hang or fold it.



Remember these points for all knitted garments.

# USING A SEWING MACHINE FOR MAKE-UP

Sewing by machine saves time and gives a good finish. You can adjust the stitch according to the type of garment you are sewing.

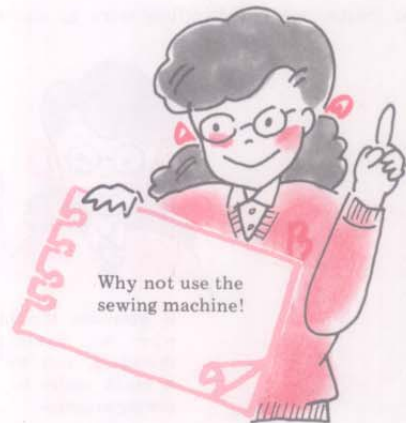

## 1: HOW TO CHOOSE A SEWING MACHINE



There are two types of sewing machine:- the straight stitch and the zig-zag. You can use both kinds for sewing knitting.

① Sewing machine

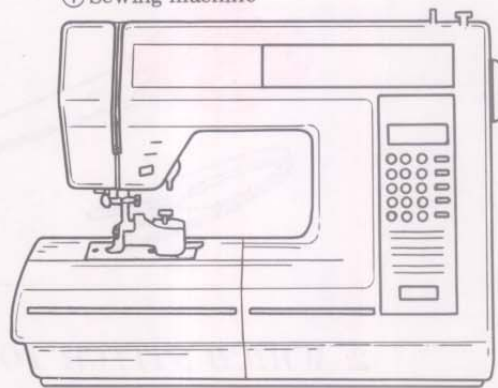

② What kind of thread should you use?

Cotton thread



Stretch thread



As knitting stretches it is better to use the special stretch threads available.

### ③ Basting

Before you baste use the binding wire as shown below.

Using a good quality basting thread and ensuring that the stitch designs match, carefully baste the seams.

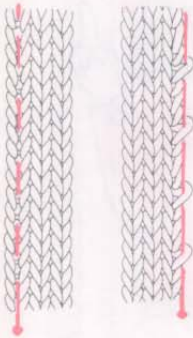

If you use the binding wire by winding or threading, you will find it much easier to use a sewing machine.

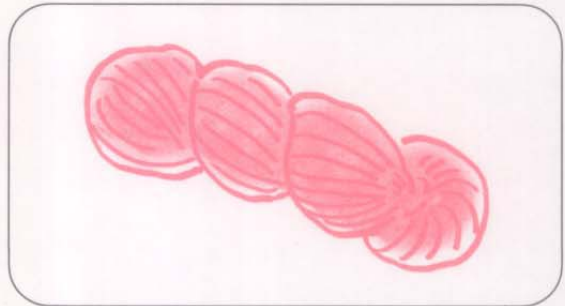

### ④ Scissors

It is essential with dressmaking and knitting alike to have a good sharp pair of scissors.

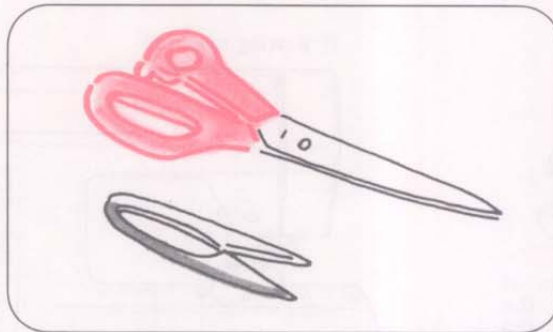

## 2: WHICH STITCH TO CHOOSE

### ① Straight stitch

### ② Zig-zag

This is the basic stitch on all sewing machines. Use this stitch where there is not a great deal of elasticity and a neat firm line is required.

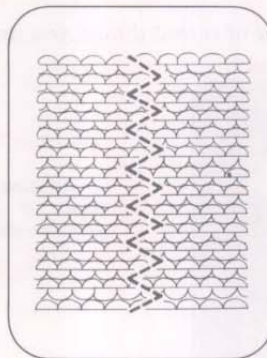
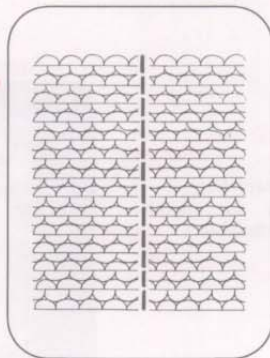

Where more elasticity is required use the zig-zag

### 3: ORDER OF MAKE-UP

Let's take as an example a sweater using a sewing machine.  
Ensure that all garment pieces are pressed well before make-up.

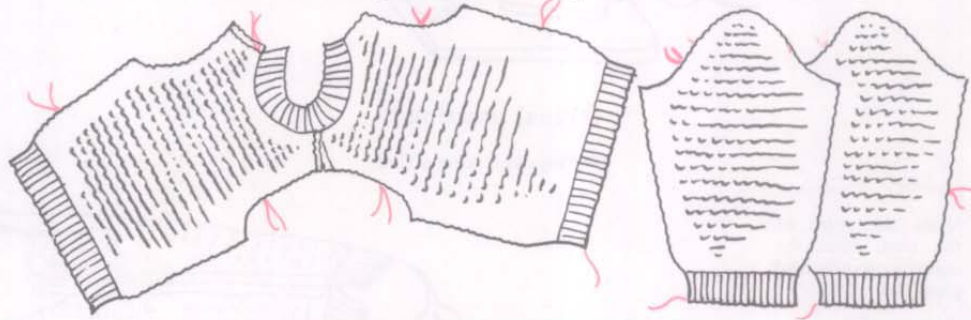

#### ● Baste first then use the sewing machine ●

① Place the two pieces with right sides together and use the binding wire.



② Baste the seam ensuring that the length of the seam is correct. Finally use the sewing machine choosing the correct stitch.

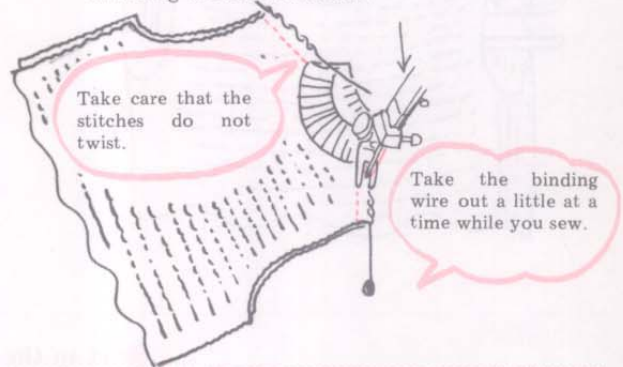

③ Join the side seams in exactly the same way. ④ After you have pinned into position thread the binding wire, check the length of the seam, baste and then use the sewing machine.

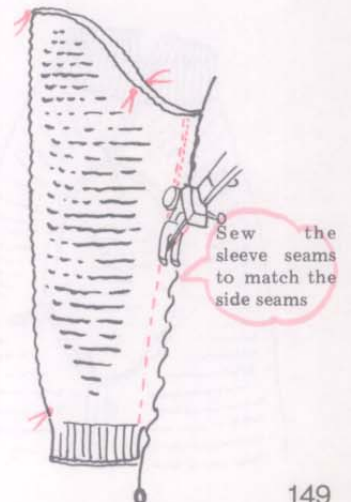



● Final pressing ●

★ Press the seams flat.

Using the point of the iron, open the seam allowance and press flat.

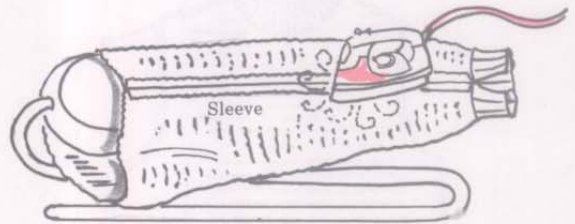
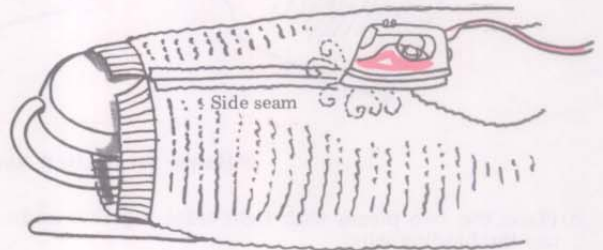

● Set in the sleeves ●

① Place the sleeve into the armhole matching markers.

② Place pins evenly.

③ Baste along the armhole edge. Check that you have not stretched the armhole or made it smaller. Sew using a sewing machine.

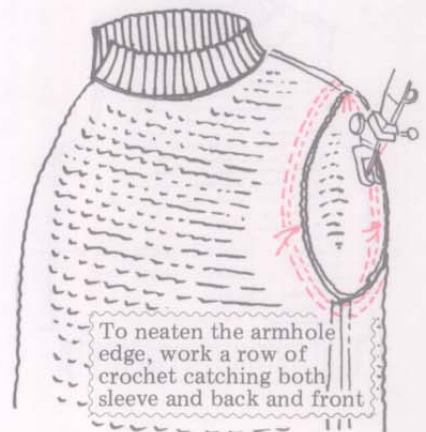
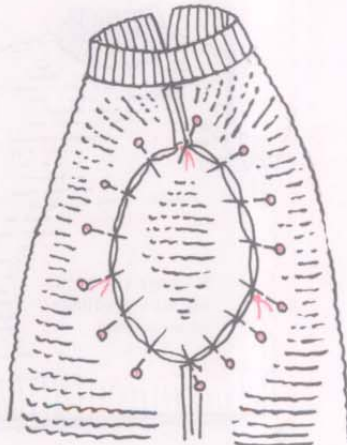
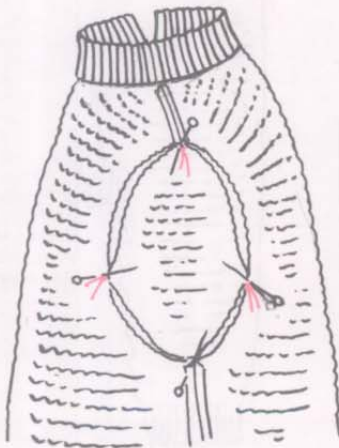

● Joining the side and sleeve seams in one ●

This is another way to set in the sleeves.



- ① Lay the back and front with the sleeve, right side facing.
- ② Pin into position.

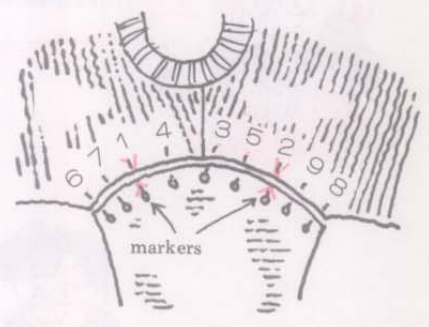
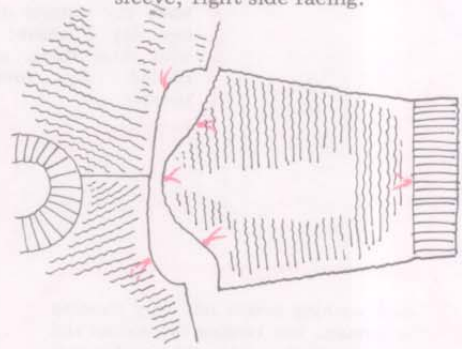

- ③ Thread the binding wire and remove the pins.
- ④ Baste and then sew using a sewing machine, 0.5cm from edge.
- ⑤ Open the seam allowance and press.

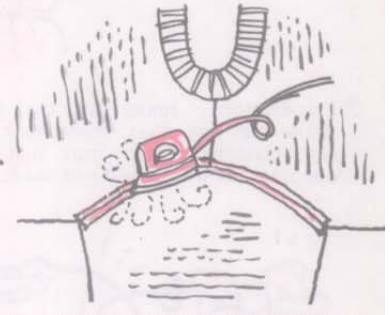
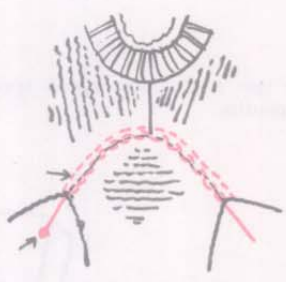

- ⑥ With the right side of the garment facing, match up the side and sleeve seams.

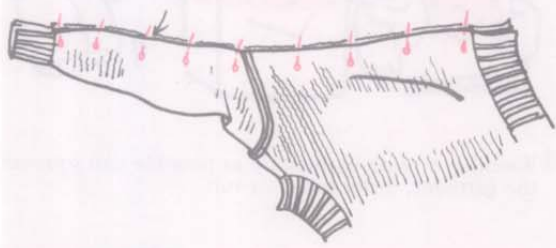

- ⑦ Baste.

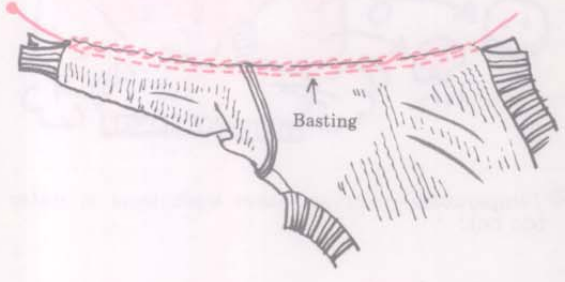

- ⑧ Sew from the cuff to the hemline. Take out the wire.

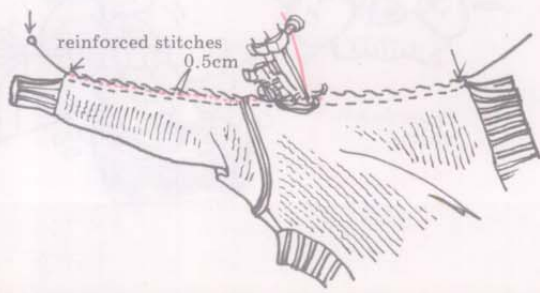

- ⑨ Open the seam allowance and press.

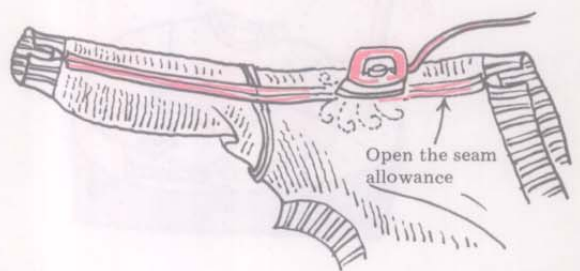

# HOW TO WASH KNITWEAR



How do you wash your knitwear?

I didn't know how to wash my sweater and one day I washed it with other things and spoiled my lovely sweater.



Good washing means not only cleaning the garment, but keeping the texture and colour as good as new, this is what you should know about washing.

① Preparation — make sure that the garment is dry, shake out any dust, mend any holes, and remove any buttons which may not be colour-fast or decorations which will not wash well.

② Washing agents — use a cleaning agent specially for wool for good results.

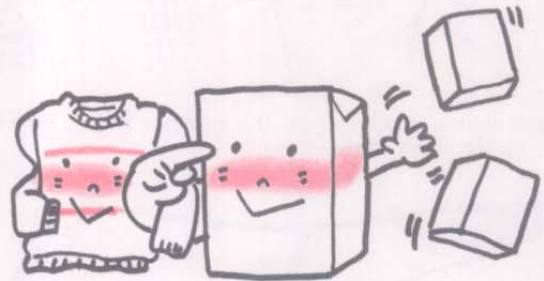

③ Temperature — never, never wash wool in water too hot!

④ Washing — wash as quickly as possible and squeeze the garment, never brush or rub.

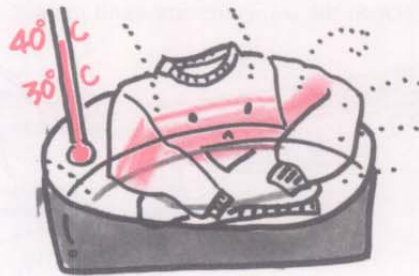



⑥ Rinsing — the temperature of the rinsing water should be the same as the washing water.



⑥ Fold the garment and press out the water. Wrap the garment in a towel to remove excess water.

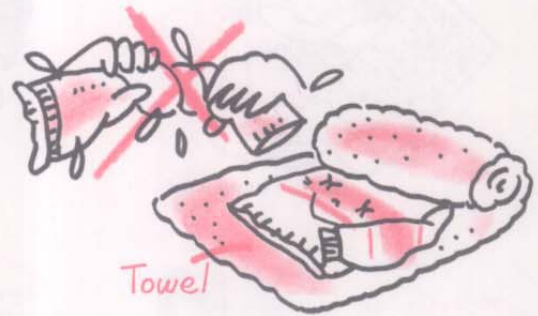

⑦ Drying — place the garment on a flat surface spreading the garment evenly. Tilt the board or set slightly to let the water drain. When it is almost dry hang the garment.



⑧ Finishing — if you must press the garment use a steam iron holding it away from the garment and being careful not to stretch it.



# MAKING YOUR OWN PUNCH CARD



Blank Punch card



Pen

Felt pen  
or  
pencil

When you  
make your  
own punch-  
card you  
need these  
3 things



Punch

Take out the  
blank card and  
mark the holes  
to be punched.



Insert the guide pin  
into the pin hole on  
the blank card,  
squeeze the handle  
tightly and a hole  
will be made.

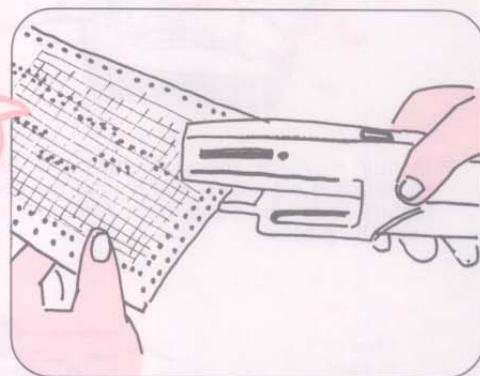

Stitch I

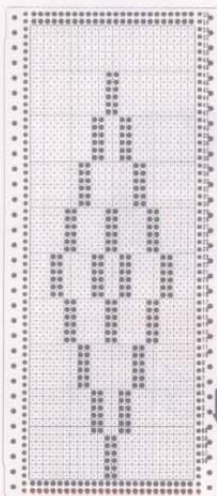

Stitch II

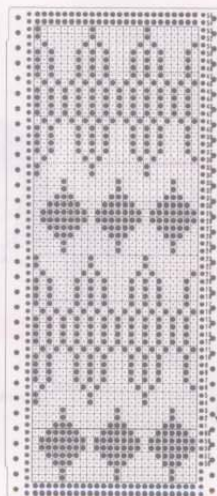

Stitch III

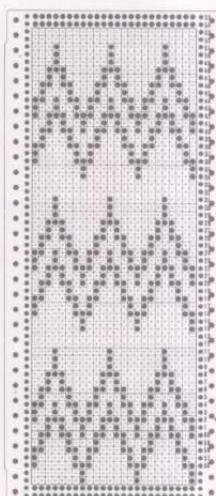

- ① The blank card has 60 rows. You do not have to use all 60 rows but you must make the card long enough so that it can rotate in the machine. If your pattern is 40 rows long, repeat it once, if your pattern is 20 rows long repeat it twice.
- ② Ensure that there are two rows of punched holes at the top and bottom of the card.
- ③ Place the card into the machine and join together. Lock the card on row 1. The first row that is selected is actually 7 rows below.
- ④ The centre of the pattern is the 12th or 13th stitch counting from the left.
- ⑤ You must have at least 36 rows punched to enable the card to rotate.



What happens when your stitch design is less than 60 rows?

① This stitch design is less than 60 rows.

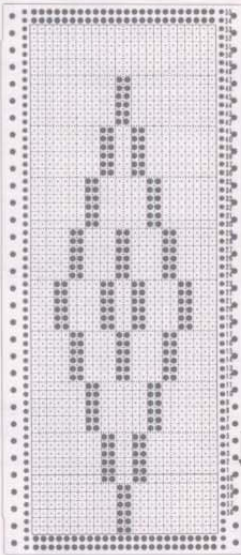

② Punch two rows of holes along the top of the design.

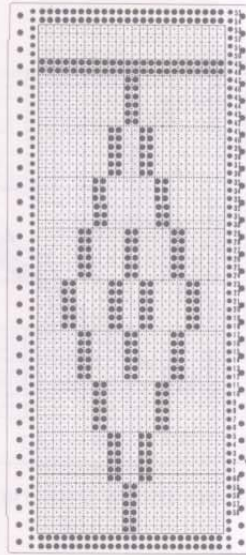

③ Cut off the top part of the card above the 2 rows of punched holes, then trim the card at the sides to enable it to join up.

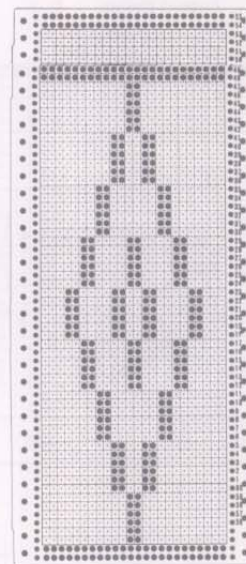

Cut off this part



What happens when your stitch design is more than 60 rows?

① Punch the first card to the top, working from the bottom.

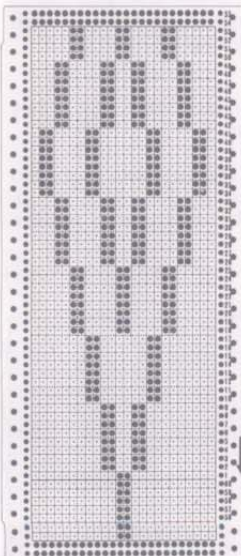

② Take a second card and punch the remaining part of the stitch design, working from the top.

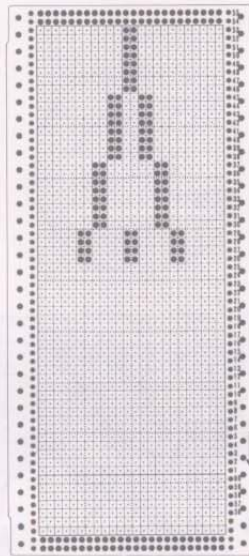

③ Punch two rows of holes at the end of the stitch design on the second card.

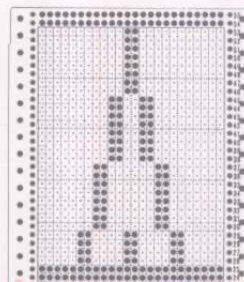

Cut off the lower part of the card below the 2 rows of punched holes. Trim the sides of the card so that it joins easily.

Using the snaps join the two cards together overlapping so the design is complete.

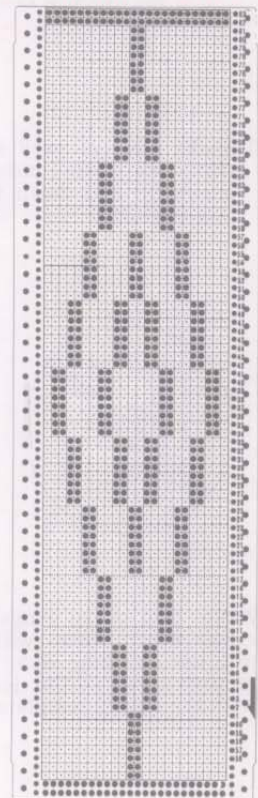

# MAKING A STITCH DESIGN FOR THE ELECTRONIC MACHINE



Use a blank sheet to draw your own, or a copied design.



How do you do this?  
I have a design I want to knit.

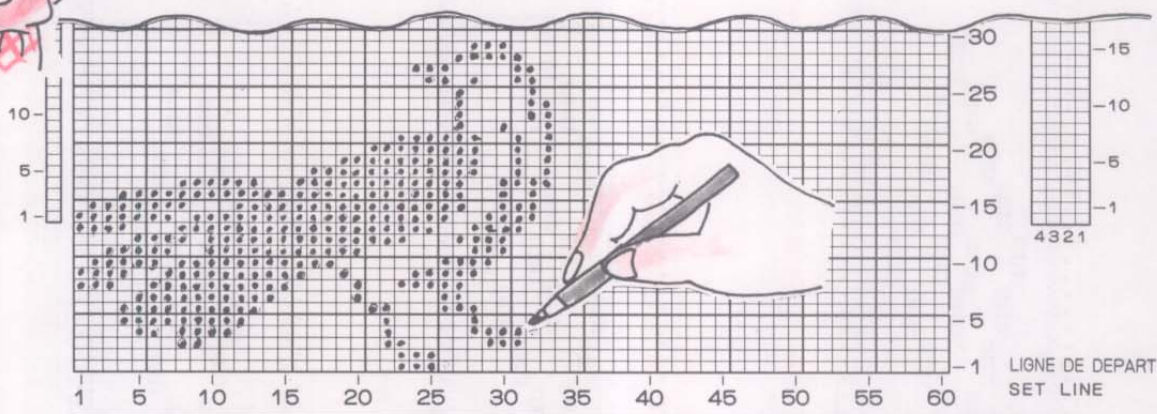

## HOW TO DRAW THE DESIGN

Make sure you use the correct side of the electronic sheet.



When drawing pattern, do not protrude beyond the next blanks

- ① Shake the pen well so that the ball inside moves up and down to mix the ink.
- ② Holding the pen downwards remove the cap and press 2 or 3 times on some paper.
- ③ When the top is full of ink test it on a piece of paper.



Only shake the pen with the cap on.

Replace the cap after use.

If the top gets damaged pull it out, turn it upside down and replace it.

When you make a mistake use the special eraser which comes with the machine — do not use anything else. When you want to remove a part of the design, protect the rest with the special template.

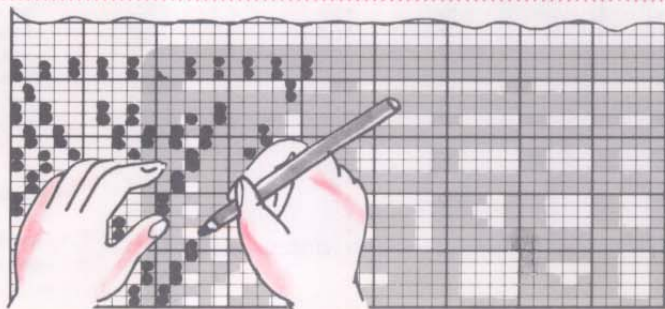

# HOW TO WORK 2×2 RIB USING A LATCHET TOOL

① Bring forward every 2 needles to B position. Knit 1 row and hang the caston comb.

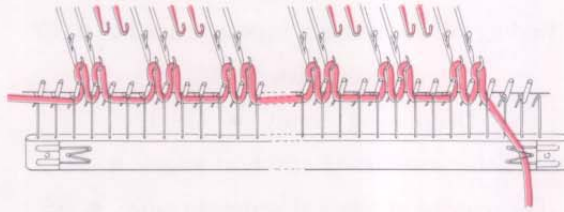

② Waste knit. Knit 1 row with the special caston thread. Set the Tension Dial to 2. Knit 3 rows at the finished edge at tighter tension.

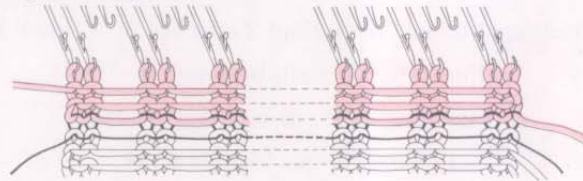

③ Using a transfer tool, pick up the sinker loop onto the empty needles as below.

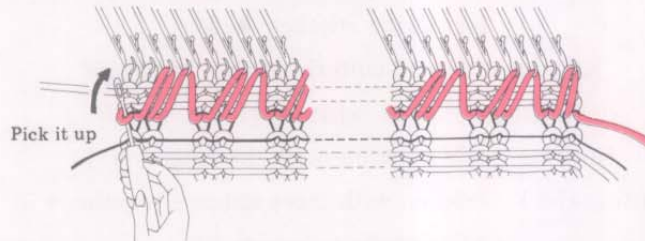

④ Set the Tension Dial to 4, and knit the required rows for 2 × 2 rib. Drop the 3rd stitch from the right.

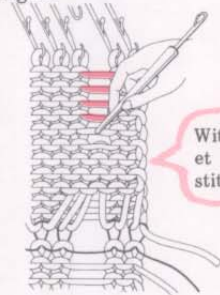

With the top of latched tool unravel the stitches

⑤ Insert the latched tool under the 1st sinker loop and catch the 4th loop and using the latched tool make a plain stitch.

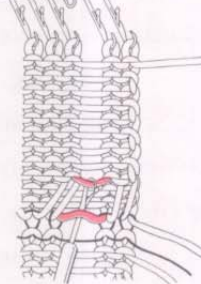

⑥ Repeat until you reach the top then hook the last stitch onto the hook of the needle.

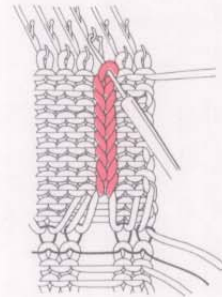

⑦ Drop the 4th stitch from the right. Make a plain stitch as shown above.

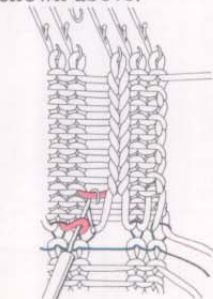

⑧ Work 2 × 2 rib with the latched tool.

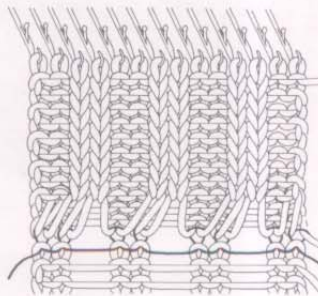

⑨ Remove the caston thread. The 2 × 2 rib. is complete.

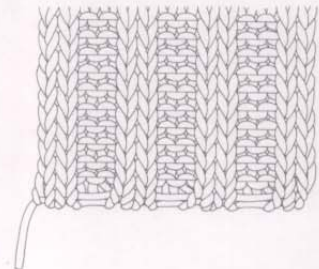

# INDEX

- Binding off by using a tapestry needle • 37
- Buttonholes • 120
- Decreasing evenly • 118, 124
- Decreasing stitches (1 stitch at edge) • 48
- Decreasing stitches (1 stitch in side) • 65
- Decreasing stitches (2 stitches in side) • 103
- Decreasing stitches (More than 2 stitches at a time) • 65
- Finishing 1×1 rib by hand • 77
- Finishing 2×2 rib by hand • 110
- Folding the neckband • 98
- Hemming • 47
- Increasing stitches • 39
- Knitting 1×1 rib. with the ribber • 29, 138
- Knitting 2×2 rib. with the ribber • 140
- Knitting the V-neckline with the ribber • 71
- Knitting the V-neckline with three stitches together • 73
- Making the lining • 52
- Partial knitting • 115
- Picking up stitches • 40
- Putting a marker • 34, 35, 36
- Sewing • 42
- Sewing buttons on • 122
- Sewing in yarn ends • 40
- Sewing the ribbed part by mattress stitch • 77, 97
- Waste knitting • 37
- Waste knitting for 1×1 rib • 74
- Working 1×1 rib. with a latchet tool • 34
- Working 2×2 rib. with a latchet tool • 157