

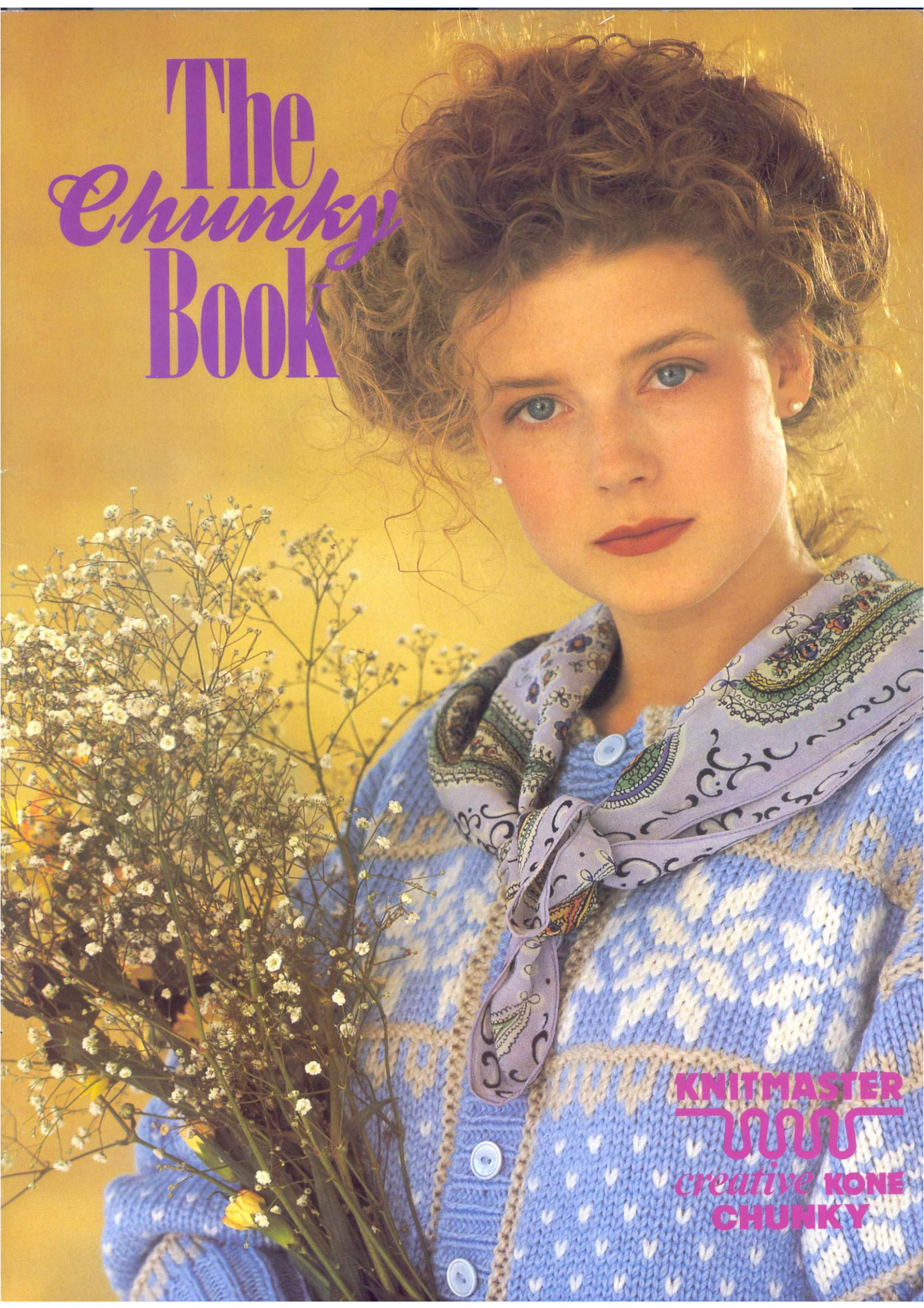

# The Chunky Book



**KNITMASTER**  
  
*creative* **KONE**  
**CHUNKY**

# The Chunky Book

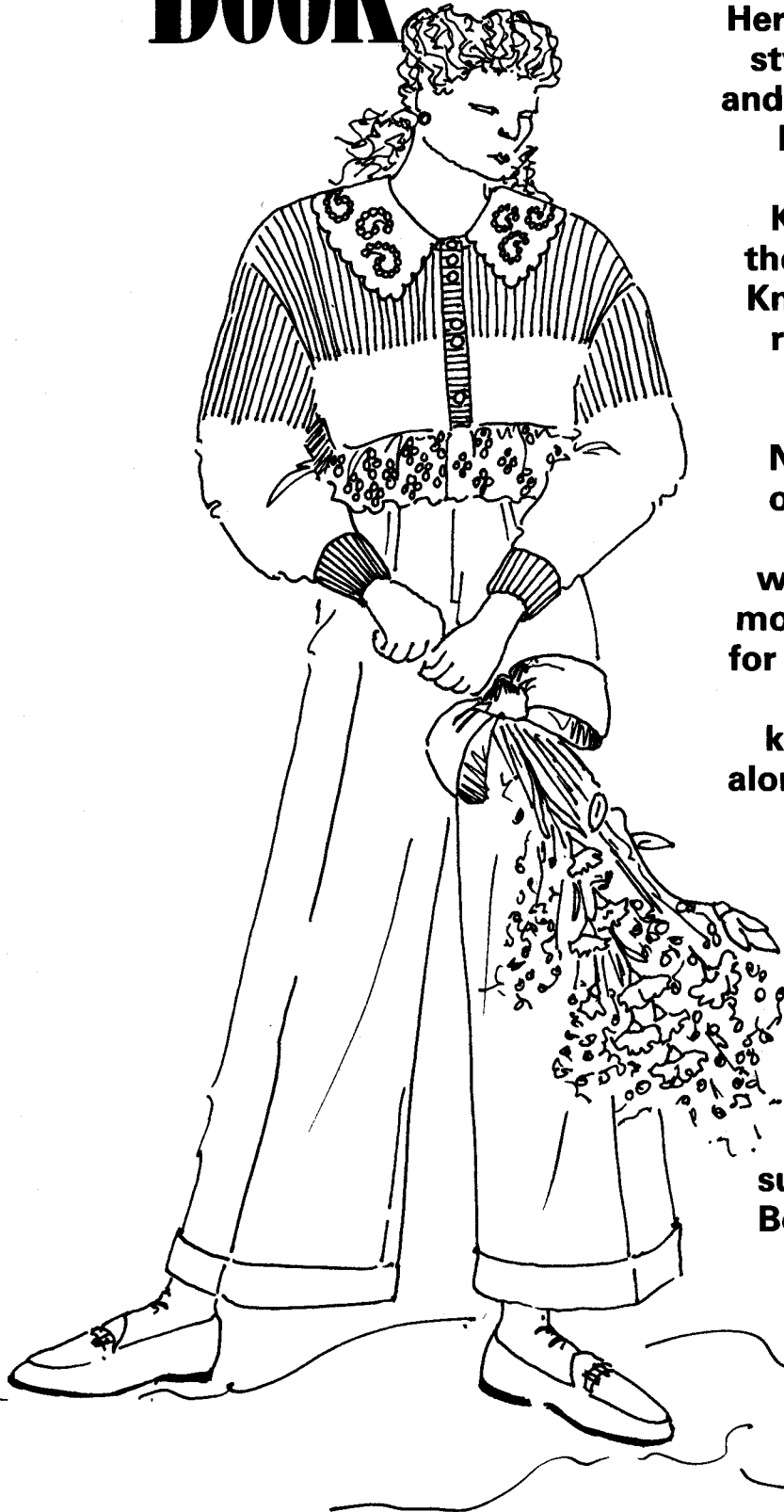

Here in **The Chunky Book** you'll find a stylish collection of timeless classics and up-to-the-minute fashion knits for both men and women. All of these designs have been knitted on **Knitmaster Chunky** machines using the gorgeous new **Chunky** yarn from **Knitmaster** — it comes in a delicious range of colours and knits superbly on all **9mm Chunky Machines**.

Not only is this complete collection of chunky knits suitable for women (many of them in the larger sizes which are not always available), but most of the collection is also suitable for men. You'll find a complete listing of sizes and which designs can be knitted for men on pages 42 and 43 along with the information which will show you at a glance which **Knitmaster Chunky** machine can be used to knit each design.

The selection of patterns included in **The Chunky Book** not only caters for beginners and experienced knitters alike but is also varied enough to suit all ages and tastes. **The Chunky Book** must surely take an important place in your pattern collection for many years to come.

# The Chunky Book

## CONTENTS

### EDITOR

Laraine McCarthy

### DESIGN

Sarah Large

### PATTERNS

Debbie Clarkson

### KNITTING

Samantha Lamb  
Janette Wilkins  
Helen Bacon

### PHOTOGRAPHY

Liz McAulay

### STYLIST

Kate Mullaney

### ACCESSORIES

Menswear — Pulse  
Shoes — Red or Dead  
Jewellery — Adrian Mann  
Hats — The Hat Shop,  
St. Christopher's Place, W1  
Dickens and Jones  
In Wear

1	Raglan V-Neck Sweater	6
2	Raglan V-Neck Cardigan	6
3	Raglan Crew Neck Sweater	6
4	Raglan Crew Neck Cardigan	6
5	Icelandic Sweater	10
6	Icelandic Cardigan	10
7	Shortie Fitted Sweater	13
8	Aran Crew Neck Sweater	16
9	Floral Cropped Sweater	19
10	English Rib Raglan Sweater	26
11	Ribby Sweater with Swiss Darning	29
12	Aran Crew Neck Cardigan	32
13	Black & White Intarsia Sweater	35
14	Traditional Fair Isle Sweater	37
15	Peplum Cardigan	39
	<b>Additional notes &amp; information</b>	<b>22</b>
	<b>How to make a knitradar pattern</b>	<b>24</b>
	<b>Abbreviations</b>	<b>28</b>
	<b>Index</b>	<b>42</b>

Although every reasonable care has been taken to ensure that the instructions and designs in this pattern book are correct. Modern Knitting Ltd. cannot accept responsibility for any errors which may have occurred in spite of such precautions. All rights reserved. Reproduction in whole or part without written permission is strictly prohibited.

A Modern Knitting Publication © 1988  
Modern Knitting is a Registered Trademark  
Printed by E E Owens & Co Ltd.

### SUITABLE FOR KNITMASTER CHUNKY MACHINES

The designs in The Chunky Book are suitable for use with all Knitmaster 9mm Chunky Machines — model nos. 150, 151, 155 and Zippy 90. Details of which model no. is required to knit each design is contained in the Index.

### KNITMASTER YARN STOCKISTS

If you encounter any problems in obtaining Knitmaster Chunky yarn please write for stockist information to Knitmaster Ltd., 39-45 Cowleaze Rd., Kingston-upon-Thames, Surrey KT2 6DT.

1

2

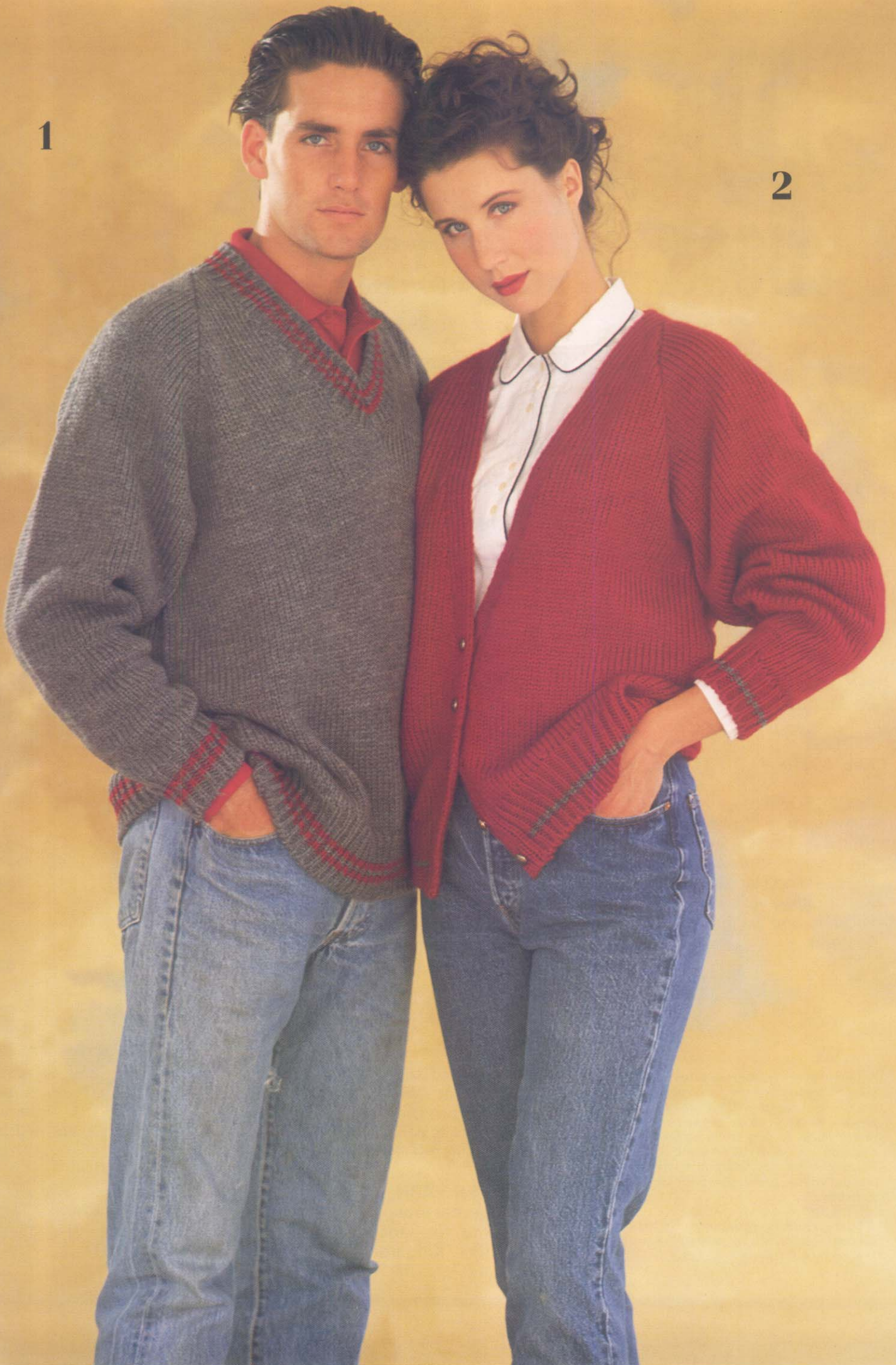

3



4



# 1 2 3 & 4 RAGLAN CREW & V-NECK SWEATER & CARDIGAN

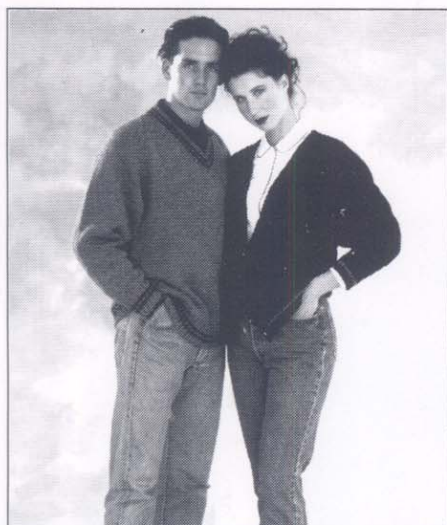

Here are four beautiful classic designs, each one in sizes for both men and women and all suitable for the full range of Knitmaster 9mm chunky machines. Knit them in any one of the sixteen delicious shades available in the Knitmaster Kone Chunky range. Stripe the ribs to introduce a fashion element and to co-ordinate your outfits.

## BACK

Push 66 (74) (81) (89) Ns to WP. Cast on as given in additional notes for Knit 1 Purl 1 Rib. RC 000. MT-5, knit 20 rows. Drop the 3rd and foll alt st and pick up as for Knit 1 Purl 1 Rib. Using waste yarn, knit 8 rows and release from machine. Push 38 (41) (45) (49) Ns at left and right of centre O to WP. 76 (82) (90) (98) Ns altog. With carr at right and wrong side facing, pick up sts from below waste yarn and place onto Ns increasing evenly. RC 000. MT. Using col 1, knit 70 (74) (80) (84) rows. Carr at right.

## Shape Armholes

Cast off 3 sts at beg of the next 2 rows\*\*.

### 1st Size Only

\*Dec 1 st at both ends of the next and ev foll alt row 3 times in all, knit 2 rows\*. Rept the last 7 rows from \*to\* 6 more times.

### 2nd Size Only

Dec 1 st at both ends of the next row, knit 2 rows.

### 3rd Size Only

\*Dec 1 st at both ends of the next and ev foll alt row 4 times in all\*. Rept the last 7 rows from \*to\* 6 more times.

### 4th Size Only

\*Dec 1 st at both ends of the next and foll alt row\*. Rept the last 3 rows from \*to\* 14 more times.

For Knitmaster 9mm Chunky Machines.

## Sizes:

To fit 81-86 (91-96) (101-106) (112-117) cms/32-34 (36-38) (40-42) (44-46) inch bust/chest.

## Materials:

Knitmaster Chunky  
Colours shown Midnight, Grey, Serpentine and Fashion Flip.

### Crew Neck Sweater

Col 1 — 630 (665) (700) (735) grms

### V-Neck Sweater

Col 1 — 640 (670) (705) (740) grms

### Crew Neck Cardigan

Col 1 — 630 (665) (700) (735) grms; 9 buttons.

## V-Neck Cardigan

Col 1 — 680 (700) (740) (770) grms; 5 buttons.

## Tensions:

Stockinet — 15 sts and 22 rows to 10 cms. TD at approx. 6 (MT)

Knit 1 Purl 1 Rib — 27 rows to 10 cms. TD at approx. MT-5

V-Neck Cardigan Border — 11 sts to 4cm and 19 rows to 10 cms. TD at approx. MT-5

## Pattern Note:

Stockinet

## Note:

When shaping V-neckband, before dec, drop the sts and pick up as for Knit 1 Purl 1 Rib.

## All sizes

Dec 1 st at both ends of the next and ev foll alt row 5 (28) (5) (7) times in all. RC 130 (134) (140) (144). Cast off rem 18 sts.

## LEFT SLEEVE

Push 33 (33) (36) (36) Ns to WP. Cast on as given in additional notes for Knit 1 Purl 1 Rib. RC 000. MT-5, knit 16 rows. Drop the 3rd and ev foll alt st and pick up as for Knit 1 Purl 1 Rib. Using waste yarn, knit 8 rows and release from machine.

Push 20 (20) (21) (21) Ns at left and right of centre O to WP 40 (40) (42) (42) Ns altog. With carr at right and wrong side facing, pick up sts from below waste yarn and place onto Ns increasing evenly. RC 000. MT. Knit 2 (2) (4) (4) rows. Inc 1 st at both ends of the next and ev foll 4th row 22 (22) (21) (21) times in all. 84 sts. Knit to Row 93 (95) (97) (99). Carr at left. (Knit 1 row extra for Right Sleeve only).

## Shape Raglan Top

Cast off 3 sts at beg of the next 2 rows.

### 1st Size Only

\*Dec 1 st at both ends of the next 11 rows, knit 1 row\*. Rept the last 12 rows from \*to\* 2 more times. Dec 1 st at both ends of the next row.

### 2nd Size Only

\*Dec 1 st at both ends of the next 5 rows, knit 1 row\*. Rept the last 6 rows from \*to\* 5 more times. Dec 1 st at both ends of the next 4 rows, knit 1 row.

### 3rd & 4th Sizes Only

\*Dec 1 st at both ends of the next and foll alt row\*. Rept the last 3 rows from \*to\* (12) (16) more times. Dec 1 st at both ends of the next (8) (0) rows.

## All Sizes

10 sts. Cast off 4 sts at beg and dec 1 st at raglan edge of the next row, knit 1 row. Dec 1 st at both ends of the next and foll alt row. Fasten off rem st.

## RIGHT SLEEVE

Knit as for Left Sleeve but note alteration in number of rows worked.

## CREW NECK SWEATER

### FRONT

Knit as for Back to \*\*.

### 1st Size Only

\*Dec 1 st at both ends of the next and ev foll alt row 3 times in all, knit 2 rows\*. Rept the last 7 rows from \*to\* 5 more times.

### 2nd Size Only

Dec 1 st at both ends of then next row, knit 2 rows. Dec 1 st at both ends of the next and ev foll alt row 20 times in all.

### 3rd Size Only

\*Dec 1 st at both ends of the next and ev foll alt row 4 times in all\*. Rept the last 7 rows from \*to\* 5 more times.

### 4th Size Only

\*Dec 1 st at both ends of the next and foll alt row\*. Rept the last 3 rows from \*to\* 13 more times.

## All Sizes:

34 (34) (36) (36) sts. RC 114 (118) (124) (128). Carr at right.

## Shape Neck

Using a length of col 1, cast off centre 14 sts. Hold Ns at left.

## Knit Right Part as Follows:—

### 1st Size Only

Dec 1 st at beg of the next 6 rows, knit 1 row. Dec 1 st at raglan edge of the next row, knit 1 row. Dec 1 st at both ends of the next row, knit 1 row. Fasten off rem st.

### 2nd Size Only

Knit 1 row. Dec 1 st at both ends of the next and ev foll alt row 3 times in all, knit 1 row. Dec 1 st at raglan edge of the next row, knit 1 row. Dec 1 st at both ends of the next row, knit 1 row. Fasten off rem st.

### 3rd Size Only

Dec 1 st at beg of the next 7 rows. Dec 1 st at raglan edge of the next row, knit 1 row. Dec 1 st at both ends of the next



row, knit 1 row. Fasten off rem st.

#### 4th Size Only

Dec 1 st at beg of then next 3 rows. Dec 1 st at both ends of the next and foll alt row, knit 1 row. Dec 1 st at raglan edge of the next row, knit 1 row. Dec 1 st at both ends of the next row, knit 1 row. Fasten off rem st.

#### All Sizes

Take carr to left. Bring Ns back to WP. Knit left part as for right part.

#### NECKBAND

Push 72 Ns to WP. Cast on as given in additional notes for Knit 1 Purl 1 Rib. RC 000. MT-5, knit 20 rows. Drop the 3rd and ev foll alt st and pick up as for Knit 1 Purl 1 Rib. Knit 1 row MT. Cast off with waste yarn.

#### TO MAKE UP

Pin out to size and steam carefully. Join raglan, side and sleeve seams. Backstitch neckband into pos and join centre back neck seam. Fold in half and catch down on the inside. Give final light steam.

#### V-NECK SWEATER

##### FRONT

Knit as for Back to \*\*. Dec 1 st at both ends of the next row, knit 1 row.

##### Shape Neck

Hold Ns at left.

Knit Right Part as Follows:—

Dec 1 st at neck edge on the next and ev foll 5th row 11 times in all, AT THE SAME TIME,

##### 1st Size Only

Dec 1 st at beg of the next and foll alt row, knit 2 rows. \*Dec 1 st at raglan edge of the next and ev foll alt row 3 times in all, knit 2 rows\*. Rept the last 7 rows from \*to\* 5 more times. Dec 1 st at raglan edge of the next and foll alt row, knit 1 row. Fasten off rem st.

##### 2nd Size Only

Knit 1 row. Dec 1 st at raglan edge of the next and ev foll alt row 25 times in all, knit 1 row. Fasten off rem st.

##### 3rd Size Only

Dec 1 st at beg of the next and ev foll alt row 3 times in all. \*Dec 1 st at raglan

edge of next and ev foll alt row 4 times in all\*. Rept the last 7 rows from \*to\* 5 more times. Dec 1 st at raglan edge of next and foll alt row, knit 1 row. Fasten off rem st.

##### 4th Size Only

Dec 1 st at raglan edge of the next row.

\*Dec 1 st at raglan edge of the next and foll alt row\*. Rept the last 3 rows from \*to\* 13 more times. Dec 1 st at raglan edge of the next and ev foll alt row 4 times in all, knit 1 row. Fasten off rem st.

#### All Sizes

Take carr to left. Bring Ns back to WP. Knit left part as for right part.

#### NECKBAND (2 pieces)

Push 57 Ns to WP. Cast on with waste yarn. RC 000. MT-5, knit 1 row. Drop the 3rd and ev foll alt st and pick up as for Knit 1 Purl 1 Rib. Dec 1 st (see note) at beg of the next and ev foll alt row 7 times in all. 50 sts. MT+4, knit 1 row. Cast off with a latch tool. Knit second piece in reverse.

#### TO MAKE UP

Pin out to size and steam carefully. Join raglan, side and sleeve seams. Backstitch neckband into pos and join seams. Give final light steam.

#### CREW NECK CARDIGAN

##### RIGHT FRONT

Push 33 (37) (41) (45) Ns to WP. Cast on as given in additional notes for Knit 1 Purl 1 Rib. RC 000. MT-5, knit 20 rows. Drop the 3rd and ev foll alt st and pick up as for Knit 1 Purl 1 Rib. Using waste yarn knit 8 rows and release from machine. Push 38 (41) (45) (49) Ns at right of centre O to WP. With carr at right and wrong side facing, pick up sts from below waste yarn and place onto Ns increasing evenly. RC 000. MT\*\*. Using col 1, knit 70 (74) (80) (84) rows. Carr at right.

##### Shape Raglan Armhole

Cast off 3 sts at beg of the next row, knit 1 row.

##### 1st Size Only

\*Dec 1 st at raglan edge of the next and ev foll alt row 3 times in all, knit 2 rows\*. Rept the last 7 rows from \*to\* 4 more times. Dec 1 st at raglan edge of the next and ev foll alt row 3 times in all, knit 1 row.

##### 2nd Size Only

Dec 1 st at raglan edge of the next row, knit 2 rows. Dec 1 st at raglan edge of the next and ev foll alt row 19 times in all, knit 1 row.

##### 3rd Size Only

\*Dec 1 st at raglan edge of the next and ev foll alt row 4 times in all\*. Rept the last 7 rows from \*to\* 4 more times. Dec 1 st at raglan edge of the next and ev foll alt row 3 times in all, knit 1 row.

##### 4th Size Only

\*Dec 1 st at raglan edge of the next and foll alt row\*. Rept the last 3 rows from \*to\* 12 more times. Dec 1 st at raglan edge of the next row, knit 1 row.

#### All Sizes

17 (18) (19) (19) sts. RC 113 (117) (123) (127). Carr at left.

##### Shape Neck

##### 1st Size Only

Cast off 7 sts at beg of the next row. Dec 1 st at beg of the next 6 rows, knit 1 row. Dec 1 st at raglan edge of the next row, knit 1 row. Dec 1 st at both ends of the next row, knit 1 row. Fasten off rem st.

##### 2nd Size Only

Cast off 7 sts at beg and dec 1 st at raglan edge of the next row, knit 1 row. Dec 1 st at both ends of the next and ev foll alt row 3 times in all, knit 1 row. Dec 1 st at raglan edge of the next row, knit 1 row. Dec 1 st at both ends of the next row, knit 1 row. Fasten off rem st.

##### 3rd Size Only

Cast off 7 sts at beg and dec 1 st at raglan edge of the next row. Dec 1 st at beg of the next 7 rows. Dec 1 st at raglan edge of the next row, knit 1 row. Dec 1 st at both ends of the next row, knit 1 row. Fasten off rem st.

##### 4th Size Only

Cast off 7 sts at beg and dec 1 st at raglan edge of the next row. Dec 1 st at beg of the next 3 rows. Dec 1 st at both ends of the next and foll alt row, knit 1 row. Dec 1 st at raglan edge of the next row, knit 1 row. Dec 1 st at both ends of the next row, knit 1 row. Fasten off rem st.

#### LEFT FRONT

Knit as for Right Front but read left for right and vice versa.

#### NECKBAND

Push 84 Ns to WP. Cast on as given in additional notes for Knit 1 Purl 1 Rib. RC 000. MT-5, knit 5 rows. Drop the 3rd and ev foll alt st and pick up as for Knit 1 Purl 1 Rib. Counting from the right edge transfer the 4th st onto adjacent N, leave empty N in WP. Knit 10 rows. Drop the 3rd and ev foll alt st and pick up as for Knit 1 Purl 1 Rib. Make another buttonhole over same N as before. Knit 5 rows. Drop the 3rd and ev foll alt st and pick up as for Knit 1 Purl 1 Rib. Knit 1 row MT. Cast off with waste yarn.

#### BUTTONHOLE BAND (Knit in 2 pieces on Zippy 90)

Push 90 (93) (96) (99) Ns to WP. Cast on as given in additional notes for Knit 1 Purl 1 Rib. RC 000. MT-5, knit 5 rows. Drop the 3rd and ev foll alt st and pick up as for Knit 1 Purl 1 Rib. Make 8 evenly spaced buttonholes over 1 N. Knit 5 rows. Drop the 3rd and ev foll alt st and pick up as for Knit 1 Purl 1 Rib. Cast off with waste yarn.

#### BUTTON BAND (Knit in 2 pieces on Zippy 90)

Knit as for Buttonhole Band but omit buttonholes.

#### TO MAKE UP

Pin out to size and steam carefully. Join raglan, side and sleeve seams. Backstitch front bands into pos. Backstitch

neckband into pos, fold in half and catch down on the inside. Sew on buttons to correspond with buttonholes. Give final light steam.

## V-NECK CARDIGAN

### RIGHT FRONT

Knit as for Right Front Crew Neck Cardigan to \*\*.

Using col 1, knit 48 (52) (58) (62) rows. Carr at right.

#### Shape Front Edge

Dec 1 st at left edge on the next and ev foll 7th row 4 times in all. Carr at right.

#### Shape Raglan Armhole

Dec 1 st at front edge on the 7th and ev foll 7th row 7 times in all, AT THE SAME TIME, cast off 3 sts at beg of the next row, knit 1 row.

#### 1st Size Only

\*Dec 1 st at raglan edge of the next and ev foll alt row 3 times in all, knit 2 rows\*. Rept the last 7 rows from \*to\* 6 more times. Dec 1 st at raglan edge of the next and foll alt row, knit 1 row. Fasten off rem st.

#### 2nd Size Only

Dec 1 st at raglan edge of the next row, knit 2 rows. Dec 1 st at raglan edge of the next and ev foll alt row 25 times in all, knit 1 row. Fasten off rem st.

#### 3rd Size Only

\*Dec 1 st at raglan edge of the next and ev foll alt row 4 times in all\*. Rept the last 7 rows from \*to\* 6 more times. Dec 1 st at raglan edge of the next and foll alt row, knit 1 row. Fasten off rem st.

#### 4th Size Only

\*Dec 1 st at raglan edge of the next and foll alt row\*. Rept the last 3 rows from \*to\* 14 more times. Dec 1 st at raglan edge of the next and ev foll alt row 4 times in all, knit 1 row. Fasten off rem st.

### LEFT FRONT

Knit as for Right Front but read left for right and vice versa.

### FRONT BORDER

Push 11 Ns to WP. Cast on as given in additional notes for Knit 1 Purl 1 Rib. RC 000. MT-5, knit 5 rows. Drop the 3rd and ev foll alt st and pick up as for Knit 1 Purl 1 Rib. \*Make a buttonhole over centre N. Knit 13 (14) (15) (16) rows. Drop the 3rd and ev foll alt st and pick up as for Knit 1 Purl 1 Rib\*. Rept from \*to\* 3 more times. Make another buttonhole over same N as before. Knit 243 (247) (251) (255) rows. Drop the 3rd and ev foll alt st and pick up as for Knit 1 Purl 1 Rib. Cast off with waste yarn.

### TO MAKE UP

Pin out to size and steam carefully. Join raglan, side and sleeve seams. Pin front border into pos. Unravel surplus rows, if required. Cast off. Sew into pos. Sew on buttons to correspond with buttonholes. Give final light steam.

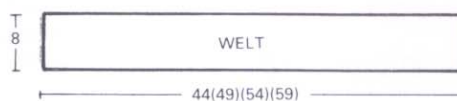
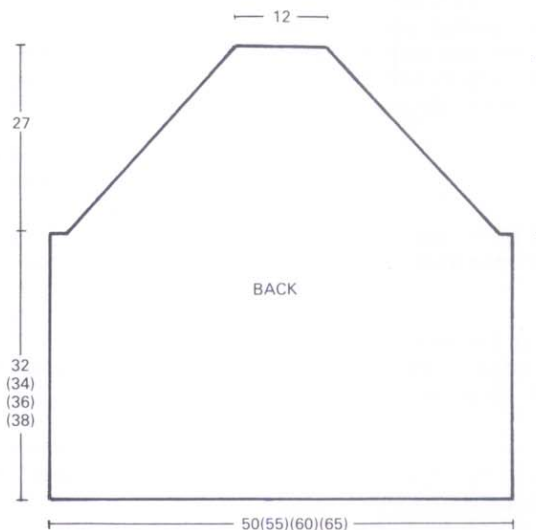
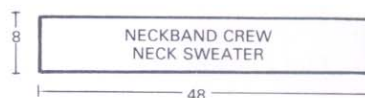
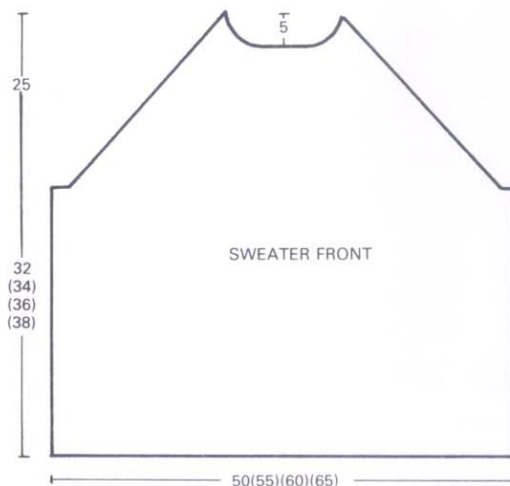



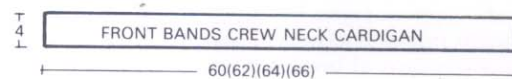
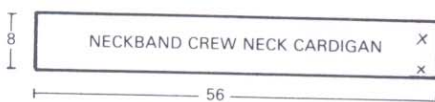
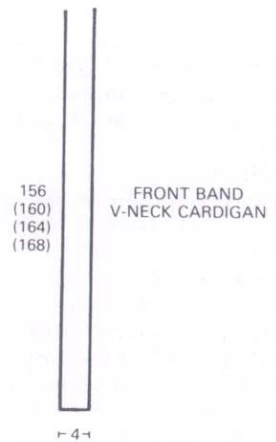
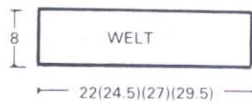
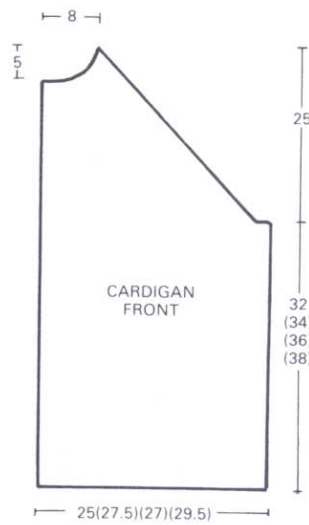
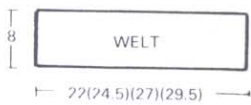
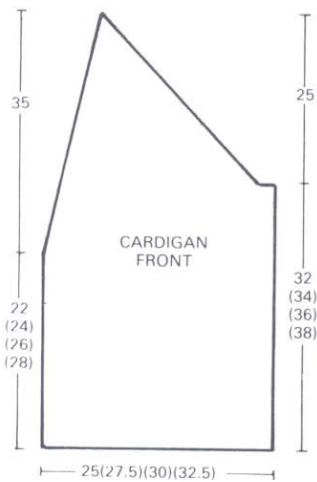
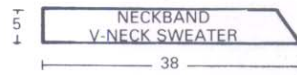
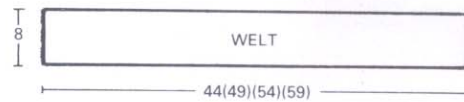
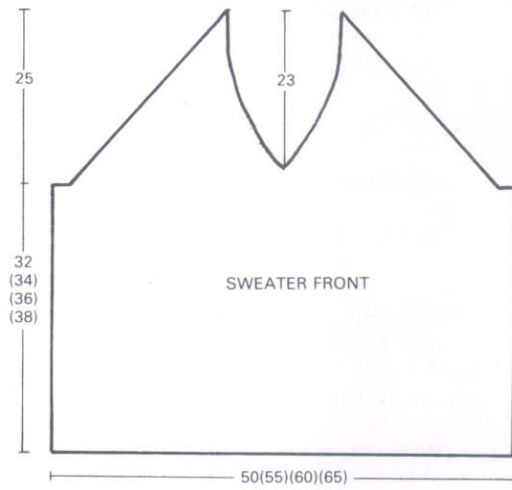
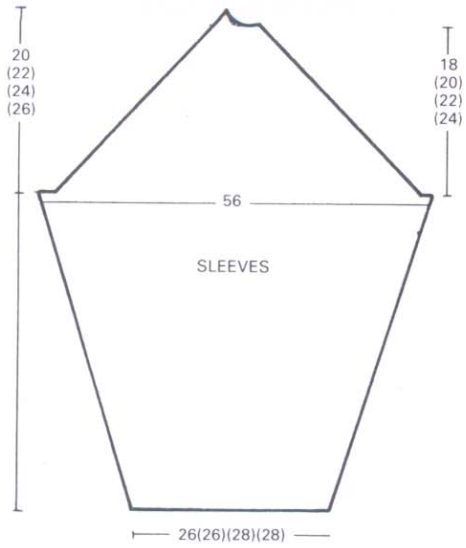

# 5 & 6 ICELANDIC SWEATER AND CARDIGAN



Icelandic style sweaters and cardigans have long been a favourite for stylish winter wear. These two beautiful examples have been knitted in a particularly effective and unusual colour combination which will be hard to better. However, don't be afraid to experiment with some of your own colour combinations, especially if you have some part cones you'd like to use up.

## BACK

Push 73 (81) (90) (98) Ns to WP. Cast on as given in additional notes for Knit 1 Purl 1 Rib. RC 000. MT-6, knit 20 rows. Drop the 3rd and ev foll alt st and pick up as for Knit 1 Purl 1 Rib. Cast off with waste yarn. Push 42 (46) (50) (54) Ns at left and right of centre O to WP. 84 (92) (100) (108) Ns altog. With carr at right, pick up sts from below waste yarn and place onto Ns increasing evenly. Insert card 1 into machine and lock on row 1. Take carr across twice without knitting. RC 000. MT. Release card. Set carr for Fair Isle. Continue in Pattern A. Knit 68 (72) (76) (80) rows. Mark both ends with waste yarn\*. Knit 56 rows. Carr at right. Shape Back Neck

Note row number showing on pattern panel. Using a length of col 1, cast off centre 18 sts. Hold Ns at left.

Knit Right Part as Follows:-

Knit 1 row. Cast off 2 sts at beg of the next and foll alt row. Cast off rem 29 (33) (37) (41) sts. Carr at right. Set card to row previously noted and lock. Take carr to left. Release card. Bring Ns back to WP. Knit left part as for right part. Remove card.

## SLEEVES

Push 37 (37) (40) (40) Ns to WP. Cast on as given in additional notes for Knit 1 Purl 1 Rib. RC 000. MT-6, knit 20 rows. Drop the 3rd and ev foll alt st pick up as

For Knitmaster 9mm Chunky Punchcard Machines.

## Sizes:

To fit 81-86 (91-96) (101-106) (112-117) cms/32-34 (36-38) (40-42) (44-46) inch bust/chest.

## Materials:

Knitmaster Chunky

### Sweater

Col 1 (Cloud Blue) — 520 (600) (680) (760) grms

Col 2 (Oatmeal) — 105 (110) (110) (115) grms

Col 3 (White) — 190 (215) (235) (255) grms

### Cardigan

Col 1 (Cloud Blue) — 520 (600) (680) (760) grms

Col 2 (Oatmeal) — 125 (135) (145) (155) grms

Col 3 (White) — 190 (215) (235) (255) grms

13 buttons.

## Tensions:

Fair Isle Patterns 1 and 3 — 16.5 sts and 23.5 rows to 10 cms. TD at approx. 7 (MT)

Fair Isle Pattern 2 — 16.5 sts and 21 rows to 10 cms. TD at approx. MT+1  
Knit 1 Purl 1 Rib — 27 rows to 10 cms. TD at approx. MT-6

## Pattern Note:

Fair Isle — see punchcard charts.

### Pattern A

Col 1 in feeder 1, Col 2 in feeder 2, knit 4 rows.

Col 2 only, knit 2 rows. Drop ev st 1 row down and pick up as for ribbing.

Col 1 in feeder 1, Col 3 in feeder 2, knit 6 rows.

Col 2 only, knit 2 rows. Drop ev st 1

for Knit 1 Purl 1 Rib. Cast off with waste yarn. Push 22 (22) (23) (23) Ns at left and right of centre O to WP. 44 (44) (46) (46) Ns altog. With carr at right, pick up sts from below waste yarn and place onto Ns increasing evenly. Insert card 1 into machine and lock on row 1. Take carr across twice without knitting. RC 000. MT. Release card. Set carr for Fair Isle. Continue in Pattern B. Knit 4 rows. Inc 1 st at both ends of the next and ev foll 5th row 4 (6) (12) (14) times in all, knit 3 rows. Inc 1 st at both ends of the next and ev foll 4th row 19 (17) (10) (8) times in all. 90 sts. Knit 2 rows. RC 98 (100) (102) (104). Mark centre with waste yarn. Cast off.

## SWEATER

### FRONT

Knit as for Back to \*. Knit 44 rows. RC 112 (116) (120) (124). Carr at right.

### Shape Neck

Note row number showing on pattern

row down and pick up as for ribbing. Col 1 in feeder 1, Col 2 in feeder 2, knit 4 rows.

Remove card. Insert card 2 into machine and lock on row 1. Set carr for stockinet. MT+1. Col 1 only, knit 2 rows. Release card. Set carr for Fair Isle.

\*Col 1 in feeder 1, Col 3 in feeder 2, knit 1 row. Col 1 only, knit 2 rows\* and\*\*. Rept from \*to\* 18 (19) (20) (21) more times.

\*\*\*Col 1 in feeder 1, Col 3 in feeder 2, knit 1 row.

Remove card. Insert card 3 into machine and lock on row 1. Set carr for stockinet. Col 1 only, knit 2 rows. Release card. Set car for Fair Isle. MT.

Col 1 in feeder 1, Col 2 in feeder 2, knit 4 rows.

Col 2 only, knit 2 rows. Drop ev st 1 row down and pick up as for ribbing. Col 1 only, knit 1 row.

Col 1 in feeder 1, Col 3 in feeder 2, knit 15 rows.

Col 1 only, knit 1 row.

Col 2 only, knit 2 rows. Drop ev st 1 row down and pick up as for ribbing.

Col 1 in feeder 1, Col 2 in feeder 2, knit 4 rows. Remove card\*\*\*.

Insert card 2 into machine and lock on row 1. Set carr for stockinet. MT+1. Col 1 only, knit 2 rows. Release card. Set carr for Fair Isle.

\*With col 1 in feeder 1, Col 3 in feeder 2, knit 1 row. Col 1 only, knit 2 rows\*. Rept from \*to\* throughout.

### Pattern B

Knit as for Pattern A to \*\*. Rept from \*to\* 13 (14) (15) (15) more times. Knit as for Pattern A from \*\*\*to\*\*\*. Set carr for stockinet and continue in col 1.

panel. Using a length of col 1, cast off centre 14 sts. Hold Ns at left.

Knit Right Part as Follows:-

Knit 1 row. Cast off 2 sts at beg of the next and foll alt row, knit 1 row. Dec 1 st at beg of the next and foll alt row. 29 (33) (37) (41) sts. Knit 8 rows. Cast off. Carr at right. Set card to row previously noted and lock. Take carr to left. Release card. Bring Ns back to WP. Knit left part as for right part. Remove card.

## CARDIGAN

### RIGHT FRONT

Push 36 (40) (45) (49) Ns to WP. Cast on as given in additional notes for Knit 1 Purl 1 Rib. RC 000. MT-6, knit 20 rows. Drop the 3rd and ev foll alt st and pick up as for Knit 1 Purl 1 Rib. Cast off with waste yarn. Push 42 (46) (50) (54) Ns at right of centre O to WP. With carr at right, pick up sts from below waste yarn

Continued on page 12

5



6



**PATTERNS 5 & 6**

Continued from page 10

and place onto Ns increasing evenly. Insert card 1 into machine and lock on row 1. Take carr across twice without knitting. RC 000. MT. Release card. Set carr for Fair Isle. Continue in Pattern A. Knit 68 (72) (76) (80) rows. Mark right edge with waste yarn. Knit 43 rows. RC 111 (115) (119) (123). Carr at left.

**Shape Neck**

Cast off 7 sts at beg of the next row, knit 1 row. Cast off 2 sts at beg of the next and foll alt row, knit 1 row. Dec 1 st at beg of the next and foll alt row. 29 (33) (37) (41) sts. Knit 8 rows. Cast off.

**LEFT FRONT**

Knit as for Right Front but read left for right and vice versa.

**SWEATER & CARDIGAN NECKBAND**

Push 80 Ns to WP. Cast on as given in additional notes for Knit 1 Purl 1 Rib. RC 000. MT-6, knit 20 rows. Drop the 3rd and ev foll alt st and pick up as for Knit 1 Purl 1 Rib. MT. Using col 2, knit 2 rows. Drop ev st 1 row down and pick up as for ribbing. Knit 1 row. Cast off with waste yarn.

CARD 1

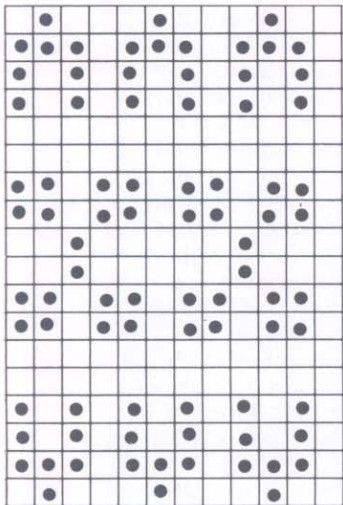

CARD 2

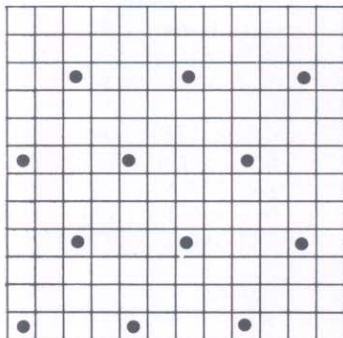

CARD 3

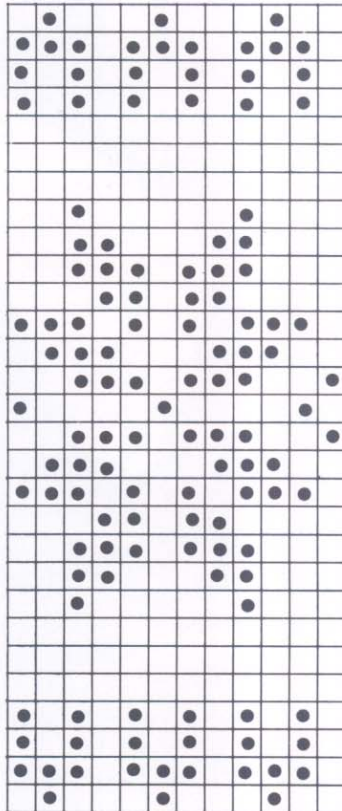

**CARDIGAN BUTTONHOLE BAND**

Push 102 (105) (108) (110) Ns to WP. Cast on as given in additional notes for Knit 1 Purl 1 Rib. RC 000. MT-6, knit 5 rows. Drop the 3rd and ev foll alt st and pick up as for Knit 1 Purl 1 Rib. Make 13 evenly spaced buttonholes over 1 N. Knit 5 rows. Drop the 3rd and ev foll alt st and pick up as for Knit 1 Purl 1 Rib. MT. Using col 2, knit 2 rows. Drop ev st 1 row down and pick up as for ribbing. Knit 1 row. Cast off with waste yarn. Knit Buttonband as for Buttonhole Band but omit buttonholes.

**SWEATER TO MAKE UP**

Pin out to size and steam carefully. Join shoulder seams. Set in sleeves between marked points. Join side and sleeve seams. Backstitch neckband into pos and join centre back seam. Fold in half and catch down on the inside. Give final light steam.

**CARDIGAN TO MAKE UP**

Pin out to size and steam carefully. Join shoulder seams. Set in sleeves between marked points. Join side and sleeve seams. Backstitch neckband into pos, fold in half and catch down on the inside. Backstitch front bands into pos. Sew on buttons to correspond with buttonholes. Give final light steam.

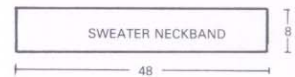
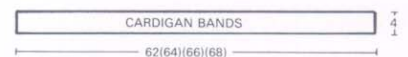
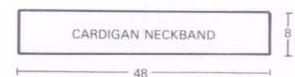
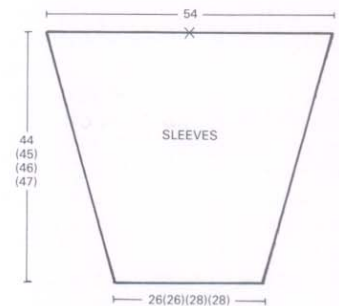
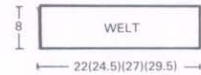
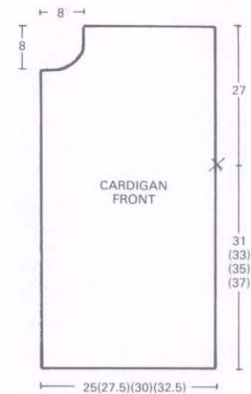
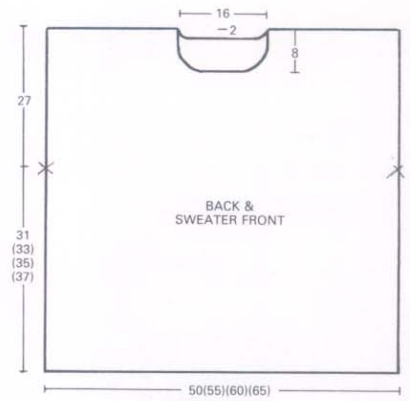

# 7 SHORTIE FITTED SWEATER



For Knitmaster 9mm Chunky Machines.

**Pattern Note:**  
Stockinet

**Sizes:**

To fit 81-86 (91-96) (101-106) cms/32-34 (36-38) (40-42) inch bust

**Materials:**

Knitmaster Chunky  
Col 1 (Midnight) — 540 (590) (640) grms

**Tensions:**

Stockinet — 15 sts and 22 rows to 10 cms. TD at approx. 6 (MT)  
Knit 1 Purl 1 Rib — 27 rows to 10 cms. TD at approx. MT-5

**Short and fitted is the latest fashionable shape for knitwear, and here is an excellent example of this new shape. Use it as a starting point for some of your own designs — perhaps swiss darn it with the flowers from pattern 9 or introduce the lace pattern from pattern 15. Or simply knit it in the fashion colour of your choice.**

**BACK**

Push 54 (62) (70) Ns to WP. Cast on as given in additional notes for Knit 1 Purl 1 Rib. RC 000. MT-5, knit 38 rows. Drop the 3rd and ev foll alt st and pick up as for Knit 1 Purl 1 Rib. Cast off with waste yarn. Push 33 (37) (41) Ns at left and right of centre O to WP. 66 (74) (82) Ns altog. With carr at right, pick up sts from below waste yarn and place onto Ns increasing evenly. RC 000. MT. Knit 5 rows. Inc 1 st at both ends of the next and ev foll 8th row 4 times in all. 74 (82) (90) sts. Knit to Row 36 (38) (40). Carr at right.

**Shape Raglan Armholes**

Cast off 3 sts at beg of the next 2 rows.

**1st Size Only**

Dec 1 st at both ends of the next and foll alt row, knit 2 rows. \*Dec 1 st at both ends of the next and ev foll alt row 3 times in all, knit 2 rows\*. \*\*. Rept the last 7 rows from \*to\* 5 more times. Dec 1 st at both ends of the next and foll alt row.

**2nd Size Only**

Cast off 2 sts at beg of the next 2 rows\*\*. Dec 1 st at both ends of the next and ev foll alt row 24 times in all, knit 1 row.

**3rd Size Only**

\*Dec 1 st at both ends of the next and foll alt row. Dec 1 st at both ends of the next row, knit 1 row\*. \*\*. Rept the last 5 rows from \*to\* 9 more times.

**All Sizes**

RC 88 (90) (92). Cast off rem 24 sts.

**FRONT**

Knit as for Back to \*\*

**1st Size Only**

Rept the last 7 rows from \*to\* 3 more times. Dec 1 st at both ends of the next row. RC 72. Carr at right.

**Shape Neck**

Using a length of col 1, cast off centre 16 sts. Hold Ns at left.

**Knit Right Part as Follows:—**

Knit 1 row. Cast off 2 sts at beg and dec 1 st at raglan edge on the next row, knit 1 row. Cast off 2 sts at beg and dec 1 st at raglan edge on the next row, knit 1 row. Cast off 2 sts at beg of the next row, dec 1 st at beg of the next 2 rows. RC 80. Fasten off rem st.

**2nd Size Only**

Dec 1 st at both ends of the next and ev foll alt row 16 times in all, knit 1 row. RC 74. Carr at right.

**Shape Neck**

Using a length of col 1, cast off centre 16 sts. Hold Ns at left.

**Knit Right Part as Follows:—**

Dec 1 st beg of the next row, cast off 2 sts beg of the next row, dec 1 st beg of the next row, cast off 2 sts beg of the next row, dec 1 st beg of the next row, cast off 2 sts beg of the next row, dec 1 st at beg of the next 2 rows. RC 82. Fasten off rem st.

**3rd Size Only**

Rept the last 5 rows from \*to\* 5 more times. Dec 1 st at both ends of the next and foll alt row, dec 1 st both ends of the next row. RC 76. Carr at right.

**Shape Neck**

Using a length of col 1, cast off centre 16 sts. Hold Ns at left.

**Knit Right Part as Follows:—**

Dec 1 st at beg of the next row, cast off 2 sts at beg of the next row, knit 1 row. Cast off 2 sts at beg and dec 1 st at end of the next row, dec 1 st at beg of the next row. Cast off 2 sts at beg of the next row, dec 1 st at beg of the next 2

rows. RC 84. Fasten off rem 2 sts.

**All Sizes**

Take carr to left. Bring Ns back to WP. Knit left part as for right part.

**LEFT SLEEVE**

Push 30 Ns to WP. Cast on as given in additional notes for Knit 1 Purl 1 Rib. RC 000. MT-5, knit 20 rows. Drop the 3rd and ev foll alt st and pick up as for Knit 1 Purl 1 Rib. Cast off with waste yarn. Push 18 Ns at left and right of centre O to WP. 36 Ns altog. With carr at right, pick up sts from below waste yarn and place onto Ns increasing evenly. RC 000. MT. Knit 5 rows. Inc 1 st at both ends of the next and ev foll 4th row 13 times in all, knit 4 rows. Inc 1 st at both ends of the next and ev foll 5th row 8 times in all. 78 sts. Knit to Row 96 (98) (100). Carr at right.

**Shape Raglan Top**

Cast off 3 sts at beg of the next 2 rows.

**1st Size Only**

\*Dec 1 st at both ends of the next 5 rows, knit 1 row\*. Rept the last 6 rows from \*to\* 4 more times. Dec 1 st at both ends of the next 3 rows, knit 1 row.

**2nd Size Only**

\*Dec 1 st at both ends of the next 3 rows, knit 1 row\*. Rept the last 4 rows from \*to\* 8 more times. Dec 1 st at both ends of the next row, knit 1 row.

**3rd Size Only**

\*Dec 1 st at both ends of the next 2 rows, knit 1 row\*. Rept the last 3 rows from \*to\* 13 more times.

**All sizes**

16 sts. RC 132 (138) (144). Carr at right. Cast off 5 sts at beg of the next row, 3 sts at beg of the next row, 4 sts at beg of the next row and 2 sts at beg of the next row. Cast off rem 2 sts.

**RIGHT SLEEVE**

Knit as for left Sleeve but in reverse.

Continued on page 17

7





# 8 ARAN CREW NECK SWEATER



For Knitmaster 9mm Chunky Machines.

### Sizes:

To fit 81-86 (91-96) (101-106) (112-117) cms/32-34 (36-38) (40-42) (44-46) inch bust/chest.

### Materials:

Knitmaster Chunky  
Col 1 (Aran) — 650 (685) (720) (755) grms

### Tensions:

Pattern — 15 sts and 22 rows to 10 cms. TD at approx. 7 (MT)  
Knit 1 Purl 1 Rib — 27 rows to 10 cms. TD at approx. MT-6

### Pattern Note:

Cable and Garter Stitch — follow chart

A combination of cables and garter stitch has been used here to create a beautifully textured effect on these classically styled sweaters. Try experimenting with alternative combinations to create your own textured fabrics — place the cables closer together or further apart, position the cables in pairs, introduce more rows of garter stitch or use garter stitch to make a diamond pattern.

### BACK

Push 66 (74) (81) (89) Ns to WP. Cast on as given in additional notes for Knit 1 Purl 1 Rib. RC 000. MT-6, knit 20 rows. Drop the 3rd and ev foll alt st and pick up as for Knit 1 Purl 1 Rib. Cast off with waste yarn. Push 37 (41) (45) (49) Ns at left and right of centre O to WP. 74 (82) (90) (98) Ns altog. With carr at right, pick up sts from below waste yarn and place onto Ns increasing evenly. RC 000. MT. Continue in pattern following chart, knit 79 (81) (83) (85) rows. Mark both ends with waste yarn\*. Knit 53 rows. RC 132 (134) (136) (138). Carr at right.

### Shape Back Neck

Note pos in pattern. Using a length of col 1, cast off centre 18 sts. Hold Ns at left.

### Knit Right Part as Follows:—

Knit 1 row. Cast off 2 sts at beg of the next row, knit 1 row. Dec 1 at beg of the next row. Cast off rem 25 (29) (33) (37) sts. Take carr to left. Bring Ns back to WP. Keeping pattern correct, knit left part as for right part.

### FRONT

Knit as for Back to \*. Knit 39 rows. RC 118 (120) (122) (124). Carr at right.

### Shape Neck

Note pos in pattern. Using a length of col 1, cast off centre 14 sts. Hold Ns at left.

### Knit Right Part as Follows:—

Knit 1 row. Cast off 2 sts at beg of the next row, knit 1 row. Dec 1 at neck edge on the next and ev foll 3rd row 3 times in all, knit 8 rows. Cast off rem 25 (29) (33) (37) sts. Take carr to left. Bring Ns back to WP. Keeping pattern correct, knit left part as for right part.

### SLEEVES

Push 33 (33) (36) (36) Ns to WP. Cast on as given in additional notes for Knit 1 Purl 1 Rib. RC 000. MT-6, knit 20 rows. Drop the 3rd and ev foll alt st and pick up as for Knit 1 Purl 1 Rib. Cast off with waste yarn. Push 20 (20) (21) (21) Ns at left and right of centre O to WP. 40 (40) (42) (42) Ns altog. Pick up sts from below waste yarn and place onto Ns increasing evenly. RC 000. MT. Continue in pattern following chart, knit 2 rows.

### 1st & 2nd Sizes only

Inc 1 st at both ends of the next and ev foll 5th row 19 times in all.

### 3rd & 4th Sizes Only

Inc 1 st at both ends of the next and ev foll 5th row 8 times in all, knit 5 rows. Inc 1 st at both ends of the next and ev foll 6th row 10 times in all.

### All Sizes

78 sts. Knit to Row 96 (98) (102) (104). Mark centre with waste yarn. Cast off.

### NECKBAND

Push 72 Ns to WP. Cast on as given in additional notes for Knit 1 Purl 1 Rib. RC 000. MT-6, knit 20 rows. Drop the 3rd and ev foll alt st and pick up as for Knit 1 Purl 1 Rib. Knit 1 row MT. Cast off with waste yarn.

### TO MAKE UP

Pin out to size and steam carefully. Join shoulder seams. Set in sleeves between marked points. Join side and sleeve seams. Backstitch neckband into pos and join centre back neck seam. Fold in half and catch down on the inside. Give final light steam.

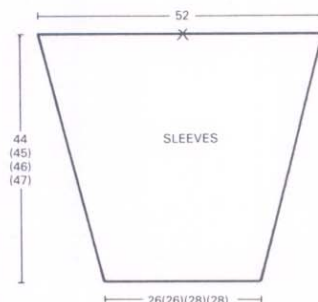
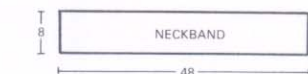
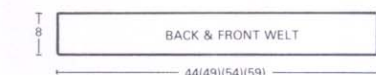
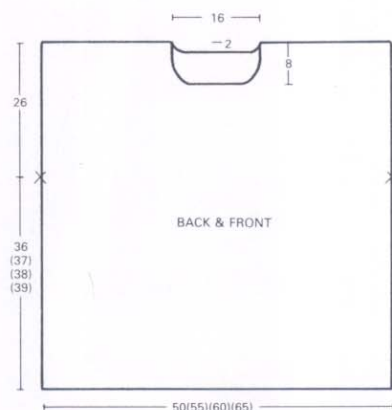



| = drop st & reform  
as for ribbing

CABLE & GARTER STITCH CHART

 = cross 3 sts at right  
over 3 sts at left

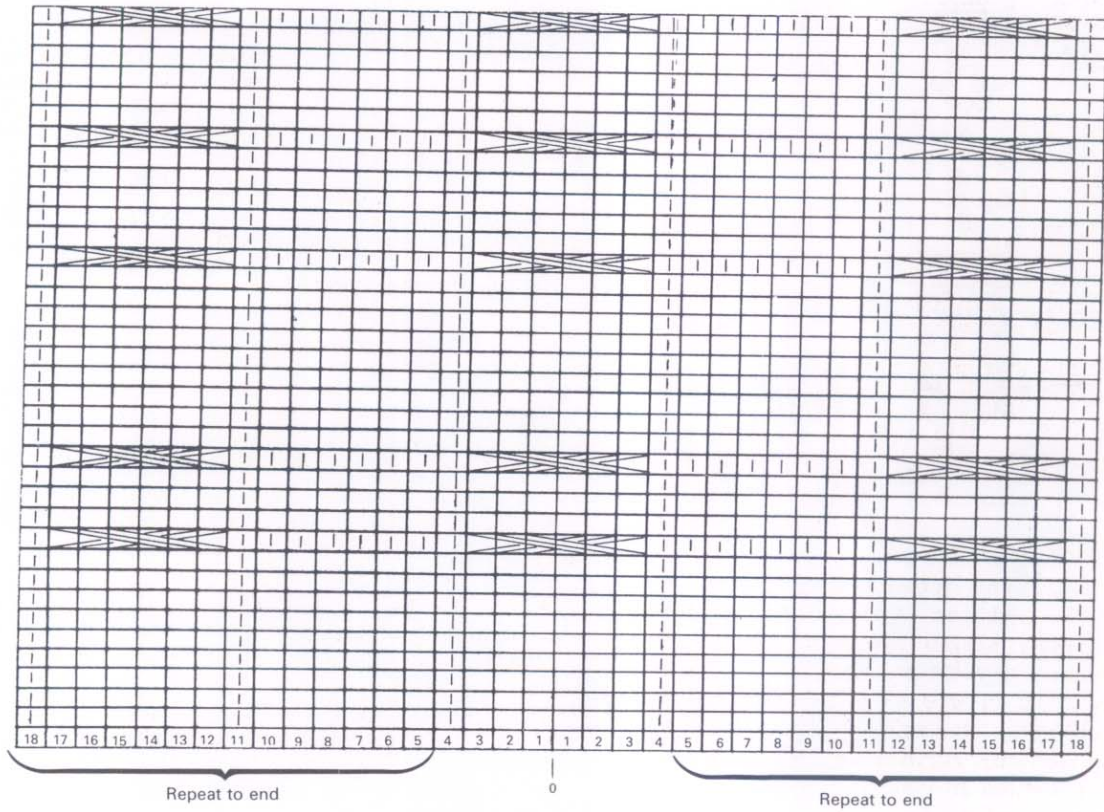

**PATTERN 7**

Continued from page 13

**NECKBAND**

Push 84 Ns to WP. Cast on as given in additional notes for Knit 1 Purl 1 Rib. RC 000. MT-5, knit 26 rows. Drop the 3rd and ev foll alt st and pick up as for Knit 1 Purl 1 Rib. Knit 1 row MT. Cast off with waste yarn.

**TO MAKE UP**

Pin out to size and steam carefully. Join raglan, side and sleeve seams. Back-stitch neckband into pos and join centre back neck seam. Give final light steam.

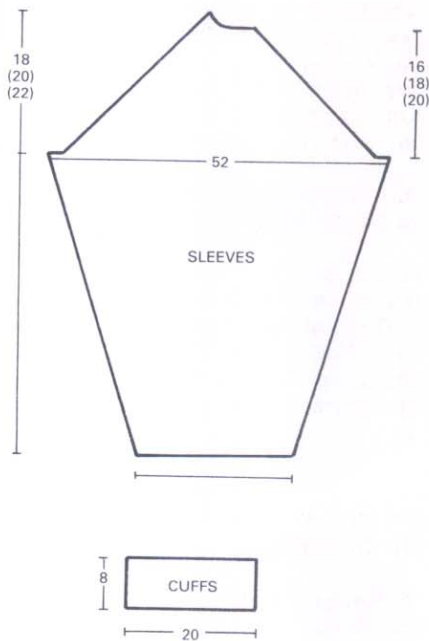
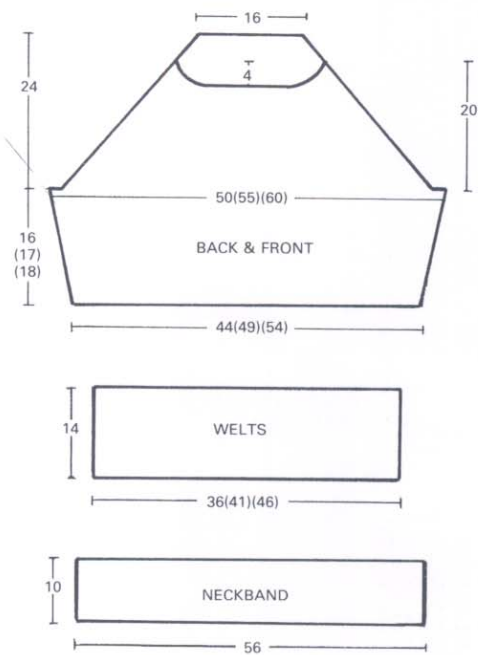

9



# 9 FLORAL CROPPED SWEATER



For Knitmaster 9mm Chunky Machines.

## Sizes:

To fit 81-86 (91-96) (101-106) (112-117) cms/32-34 (36-38) (40-42) (44-46) inch bust.

## Materials:

Knitmaster Chunky  
Col 1 (Oatmeal) — 500 (550) (600) (650) grms  
Col 2 (Pink) — 70 (85) (100) (115) grms  
Col 3 (Inca) — small amount  
Col 4 (Geranium) — small amount  
Col 5 (Bluebell) — small amount  
Col 6 (Serpentine) — small amount

## Tensions:

Stockinet — 15 sts and 22 rows to 10 cms. TD at approx. 6 (MT)

## Pattern Note:

Stockinet with swiss darning.  
Garter Stitch — \*Knit 2 rows col 1. Drop ev st 1 row down and pick up as for ribbing. Knit 2 rows col 2. Drop ev st 1 row down and pick up as for ribbing\*.

**Swiss Darning is a very easy way to embroider onto knitwear and is extremely fashionable at the moment. If you've never tried it before, you'll find instructions on page 22. Practise on a sample piece of knitting first using only one colour. You'll very quickly be adept enough to Swiss Darn these pretty flowers and other embroidery designs.**

on the next and ev foll alt row 6 times in all, knit 2 rows. Dec 1 st at neck edge on the next and foll 3rd row, knit 6 rows. Cast off rem 23 (27) (31) (35) sts. Take carr to left. Bring Ns back to WP. Knit left part as for right part.

## SLEEVES

Push 36 Ns to WP. Cast on with waste yarn. Push Ns to HP. Using col 1, cast on by hand. Push Ns to UWP. RC 000. MT. Following instructions given in pattern note for garter stitch, rept from \*to\* 4 times in all. Knit 2 rows col 1. RC 18. Drop ev st 1 row down and pick up as for ribbing. Cast off with waste yarn. Push 24 at left and right of centre O to WP. 48 Ns altog. Pick up sts from below waste yarn and place onto Ns increasing evenly. RC 000. MT. Knit 1 (2) (2) (4) rows. Inc 1 st at both ends of the next and ev foll 5th row 18 times in all. 84 sts. Knit to Row 88 (90) (92) (94). Mark centre with waste yarn. Cast off.

## NECKBAND

Push 84 Ns to WP. Cast on with waste yarn. Push Ns to HP. Using col 1, cast on by hand. Push Ns to UWP. RC 000. MT. Following instructions given in pattern note for garter stitch, rept from \*to\* 5 times in all. Knit 2 rows col 1. Drop ev st 1 row down and pick up as for ribbing. RC 22. Knit 1 row col 1, cast off with waste yarn.

## TO MAKE UP

Pin out to size and steam carefully. Following chart swiss darn flowers on front yoke. Swiss darn 1 flower at centre back neck and one flower on each sleeve. Join shoulder seams. Set in sleeves between marked points. Join side and sleeve seams. Backstitch neckband into pos, overlapping at front. Give final light steam.

## BACK

Push 66 (74) (82) (88) Ns to WP. Cast on with waste yarn. Push Ns to HP. Using col 1, cast on by hand. Push Ns to UWP. RC 000. MT. Following instructions given in pattern note for garter stitch, rept from \*to\* 4 times in all. Knit 2 rows col 1. RC 18. Drop ev st 1 st row down and pick up as for ribbing. Cast off with waste yarn. Push 37 (41) (45) (49) Ns at left and right of centre O to WP. 74 (82) (90) (98) Ns altog. With carr at right pick up sts from below waste yarn and place onto Ns increasing evenly. RC 000. MT. Knit 40 (40) (44) (44) rows. Mark both ends with waste yarn\*. Knit 60 rows. RC 100 (100) (104) (104). Carr at right.

## Shape Back Neck

Using a length of col 1, cast off centre 20 sts. Hold Ns at left.

## Knit Right Part as Follows:—

Knit 1 row. Cast off 4 sts at beg of the next row. Cast off rem 23 (27) (31) (35) sts. Take carr to left. Bring Ns back to WP. Knit left part as for right part.

## FRONT

Knit as for Back to \*. Knit 32 rows. RC 72 (72) (76) (76). Carr at right.

## Shape Neck

Hold Ns at left.

## Knit Right Part as Follows:—

Dec 1 st at neck edge on the next 6 rows, knit 1 row. Dec 1 st at neck edge

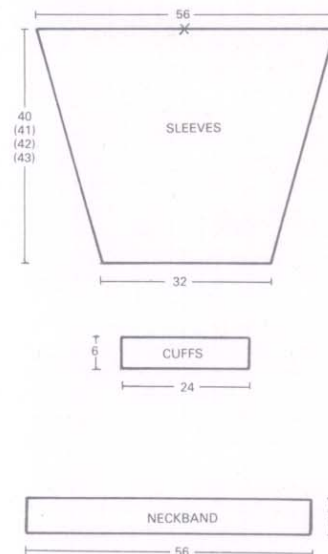
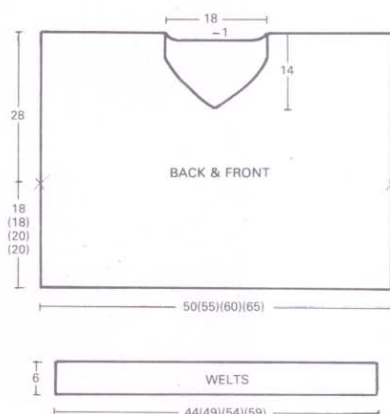
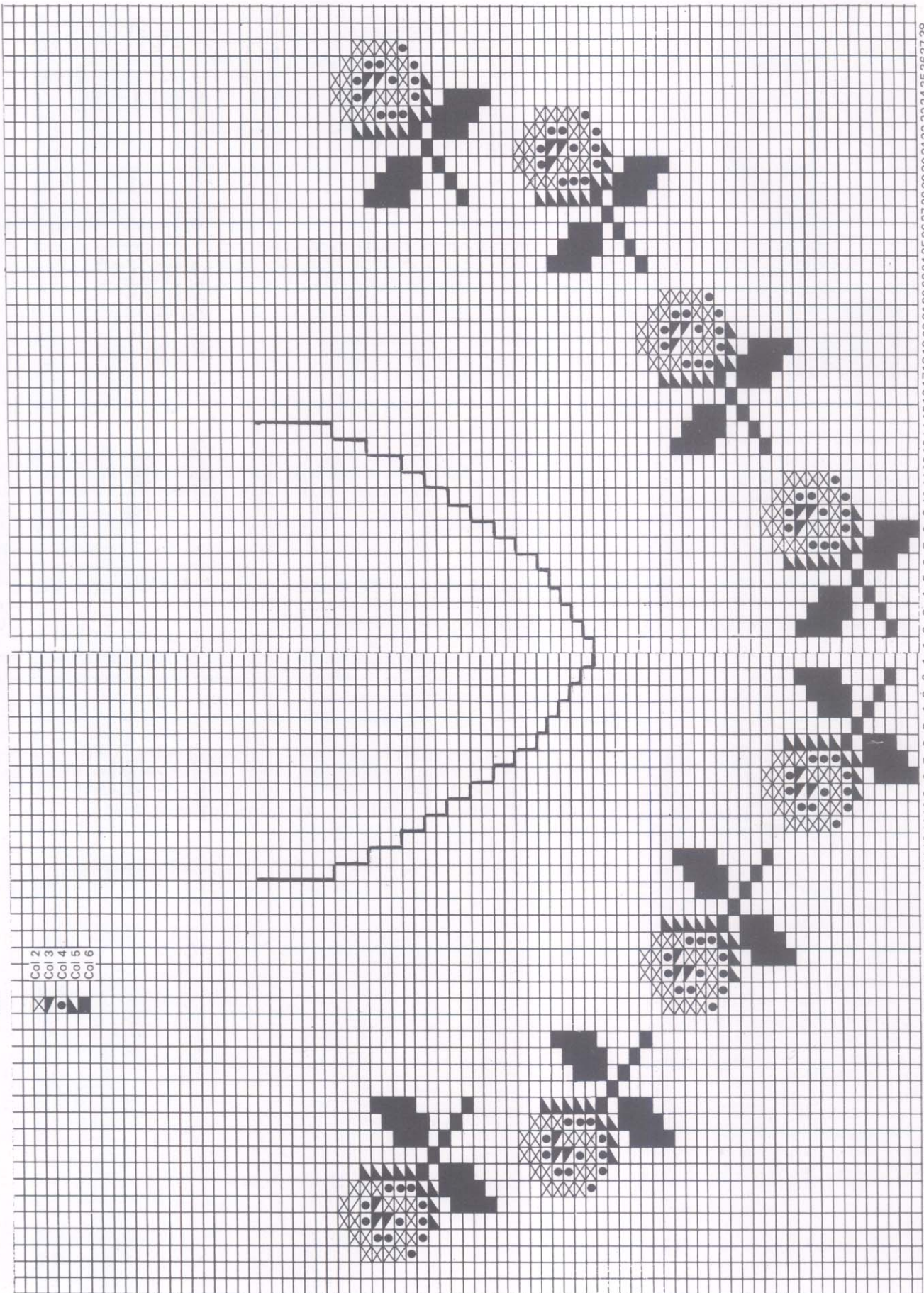

CHART FOR SWISS DARNING

KEY

- Col 2
- Col 3
- Col 4
- Col 5
- Col 6



38 37 36 35 34 33 32 31 30 29 28 27 26 25 24 23 22 21 20 19 18 17 16 15 14 13 12 11 10 9 8 7 6 5 4 3 2 1 2 3 4 5 6 7 8 9 10 11 12 13 14 15 16 17 18 19 20 21 22 23 24 25 26 27 28 29 30 31 32 33 34 35 36 37 38

# KNIT BEAUTIFUL INTARSIA KNITS ON YOUR KNITMASTER CHUNKY

Add an Intarsia Carriage to your Knitmaster Chunky and you can knit big, bold and beautiful designs right across your knitwear. Knit cuddly animal sweaters, motifs, lettering, landscapes, portraits, geometric patterns, cartoons, floral patterns — the list is endless!

When you knit with a Knitmaster Intarsia Carriage, you can have as many colours in one row as you like and you won't even have any floats at the back. Just think what beautiful designs you can produce!

Buy the AG10 Intarsia Carriage to use with Zippy 90's and the AG30 Intarsia Carriage for Chunky 155's.

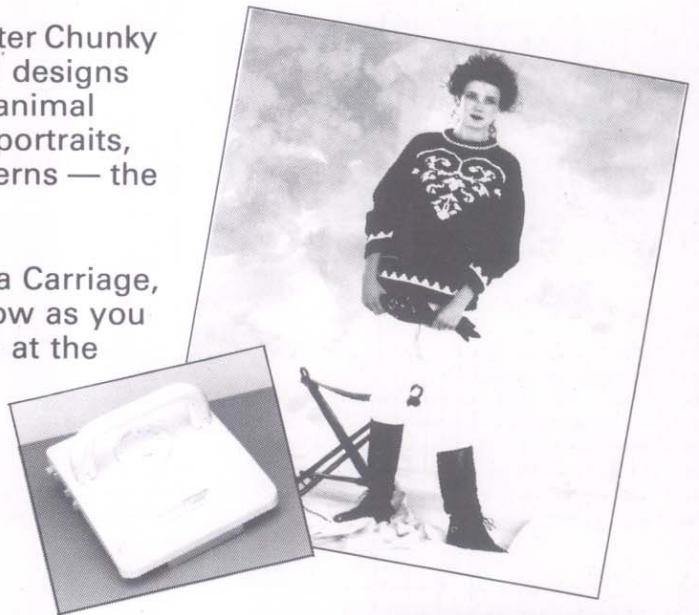

Knitmaster Intarsia Carriages are available from your local Knitmaster Stockist. Ask him for a free demonstration today.



# ZIPPY 90 KNIT & LEARN

Patterns for all 9mm Chunky Machines

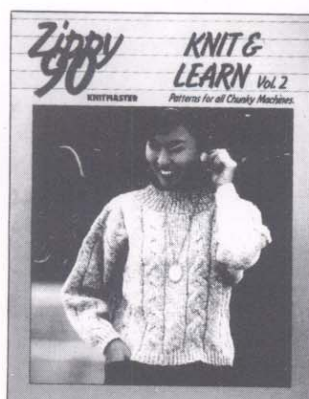
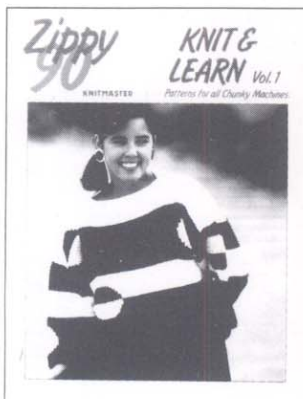

Learn while you knit — 4 chunky pattern books filled with new ideas, tips and techniques for you to learn and use on your chunky machine.

Vols 1 & 2 — Sweater patterns for men and women

Vols 3 & 4 — Summer tops for men and women

Available from your Knitmaster stockist

# Additional Notes

## Knit 1 Purl 1 Rib

Push required number of needles to Working Position.

Push the 3rd and every following alternate needle back to Non Working Position.

Cast on and knit several rows with waste yarn.

Set Tension Dial to number given in pattern for Knit 1 Purl 1 Rib. Using Main Yarn, knit 4 rows.

Insert transfer tool into the end loop of the first row of main knitting.

Lift that loop and put into the end needle. Bring the alternate needles forward to Working Position.

Knit the number of rows stated in the pattern.

Drop the 3rd and every following alternate stitch back to the waste yarn.

Using the latch tool, reform the dropped stitches in the following way.

Insert the latch tool under the loop of the first row of main knitting. Ignoring the next 3 bars, catch the yarn of the 5th row in the hook of the latch tool.

Pull the tool towards you until the first loop slips over the hook to form a new stitch.

Continue reforming stitches in this way until all the bars above have been knitted.

Replace the stitch onto the needle.

Repeat this procedure on alternate stitches until the rib is complete.

Missing 3 bars at the bottom each time gives this rib a nice firm edge.

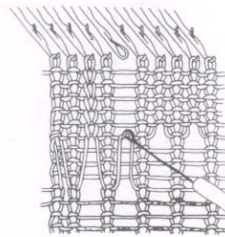
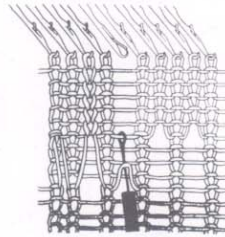
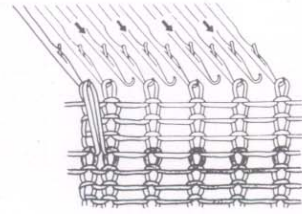
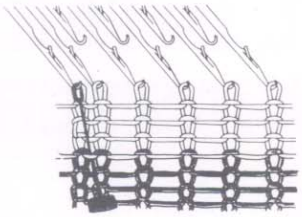

## Casting off with a Latch Tool

1. Push the needles to HP. On the opposite side to the carriage, hook the first stitch with the Latch Tool and push the needle back to NWP. The stitch is transferred to the Latch Tool.

2. Slide the first stitch behind the latch of the Latch Tool and hook the second stitch. Pull the Latch Tool towards you so that the second stitch is pulled through the first stitch. At the same time push the needle back to NWP so that the stitch is transferred to the Latch Tool.

3. Repeat in the same way all along the row. Cast off the last stitch by pulling the yarn end through the stitch.

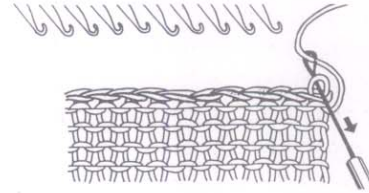
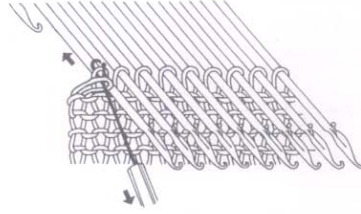
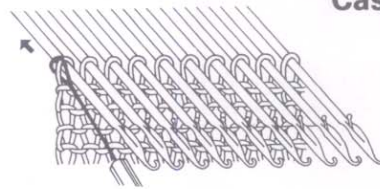

## Needle Positions

A... non-working position

B... working position

C... upper working position

D... holding position

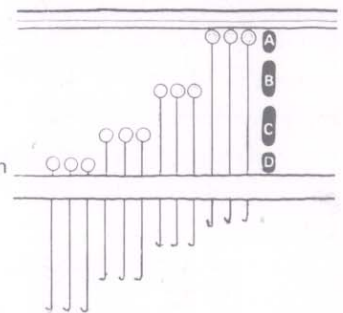

## Increasing evenly across a row

1. Push up additional needles required for increase to WP and place the stitches of the last row of main knitting onto the needles in WP omitting a needle at appropriate intervals. Remove the waste knitting.

2. Pick up the stitches of the previous row, next to the empty needle, and place them onto the empty needles.

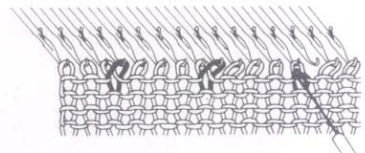
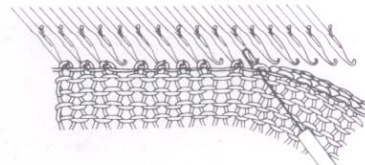

## Swiss Darning

1. Bring needle up through the base of chosen stitch.

2. Take it behind the base of stitch above chosen stitch.

3. Take needle back through base of chosen stitch.

4. Pull thread up to a suitable tension so that new stitch fits snugly over the previous one.

Repeat this to form any pattern using any colour.

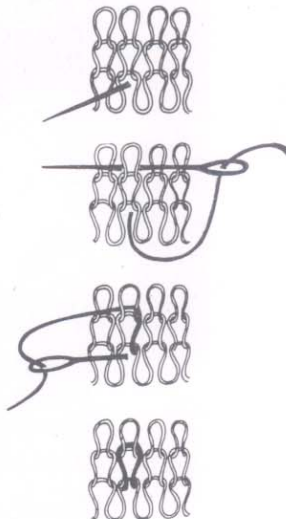

## Garter Stitch

Put the latch tool into the stitch below the one on the needle.

Drop the stitch by bringing the needle out to holding position then back to working position.

Catch the bar of the dropped stitch in the hook of the latch tool, pull through the stitch below and replace on the needle.

Repeat all along the row.

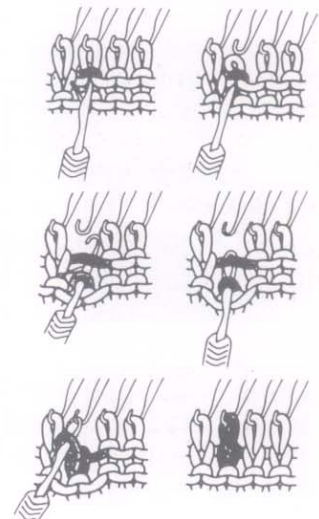

# Additional Notes

## IF YOU HAVE A RIBBER

Most of the patterns in this book give instructions for making a Knit 1 Purl 1 Rib using the latch tool. However, if you are lucky enough to own a ribber, you can knit these ribs much more quickly by following the instructions given for K1. P1 Rib in your Chunky Ribber Instruction Book.

## ADJUSTING THE LENGTH

The pattern sizes given are based on standard measurements, but you may want to add or reduce the length of the body and the sleeves. The makeup diagram gives the measurements of the garment so you can check the lengths and decide if you need to make any alterations.

To adjust the length you will have to calculate how many rows you must add or subtract. eg. To add 2cms to the length.

If 10cms = 44 rows      1cm = 4.4 rows  
Therefore 2cms = 8.8 rows = 8 rows

Always take the rows to the nearest even number. An odd number will mean your carriage will be on the opposite side to that stated in the pattern. Also remember to make the same adjustment to the front of the garment as you make to the back.

You should decide on adjustments before starting to knit. That way, if you want to shorten the length, you won't have to undo rows that you have already knitted.

When you have completed your adjustments, you must reset the row counter to show the same rows as stated at that point in the pattern. If you don't do this, the row readings will not be the same as those given throughout the rest of the pattern.

# Modern Machine Knitting

Every month there's a wonderful machine knitting magazine which is filled with beautiful designs for you to knit, design features to inspire you, hints and tips to increase your knowledge of machine knitting plus lots of other knitting machine news and information you'll love to read.

Modern Machine Knitting is available every month from your Knitmaster stockist, or write for subscription details to:-

Modern Knitting Ltd.,  
P O Box 175,  
Kingston-upon-Thames,  
Surrey KT2 6HA.



# How to make a Knitradar pattern using the diagrams

## Equipment you will need

To make a Knitradar pattern you will find it useful to have the following pieces of equipment: a Triangular Half Scale, a Freeline Drawer and a Knitradar Tracing Roll. These are all available from your Knitmaster stockist.

## How to use your Triangular Half Scale

Look at your Triangular Half Scale, you will notice that one side is marked in inches and the other side in centimetres. All the pattern diagrams show the measurements in centimetres so you must use the centimetre side for drawing your Knitradar patterns. However, if you still like to think in inches, you can turn your Half Scale over after you have drawn the pattern and see what the measurements are in inches.

You will also notice that the measurements on your Triangular Half Scale are shown in two different ways. The longest edge is marked full scale while the 2 shorter edges are marked half scale. Use the 2 shorter edges to draw your Knitradar pattern and it will automatically be drawn to half scale – suitable for use with your Knitradar. As you will see there are no calculations to make for half scale patterns – the Triangular Half Scale does all the work for you. However, there is a remarkable benefit to half scale patterns – you don't need the huge working surface required to draw full scale patterns.

## To make the Knitradar pattern

Cut a suitable length of paper from the tracing roll – you will need to leave approx. 20 cms blank at the bottom of the paper before starting your pattern. This blank piece is necessary to allow the tracing paper to be fed into your Knitradar.

### KR7 Owners

Using the longest edge of your Triangular Half Scale, draw a line 16½ cms in from and parallel to the left edge of your length of tracing roll. This line represents centre "O" on your machine.

### KR6 Owners

Using the longest edge of your Triangular Half Scale, draw a line ¼" in from and parallel to the left edge of your length of tracing roll. This line represents centre "O" on your machine.

The pattern diagrams are drawn in full but you should only draw half the shape onto your Knitradar paper, (unless the diagram is already a half shape, such as a cardigan front). See example 1.

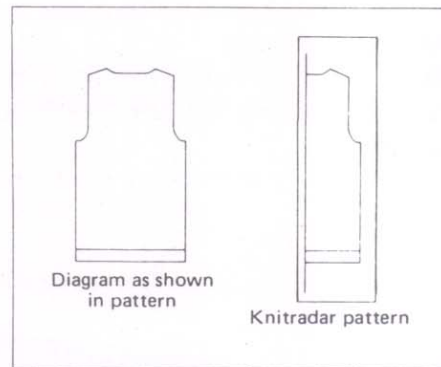

Example 1

### KR6 and KR7 Owners

The centimetre measurements are given on the diagrams. Using the 2 shorter centimetre edges of your Triangular Half Scale, draw the measurements onto your length of tracing roll. KR6 owners, remember, when you are drawing half the shape, some of your width measurements must be halved eg, chest and neck widths. All length measurements remain the same as do width measurements such as the shoulder.

Use the Freeline Drawer to draw the curves on your pattern. You will find it a great help for necklines, armholes and sleeveheads.

## Some Exceptions to the rule

Occasionally, the method given for drawing Knitradar patterns from the diagrams will differ. This will happen in the case of shapes which are not symmetrical and they will fall into two categories.

The first affects only KR6 owners and will involve shapes which will fit easily

onto the width of the tracing paper, such as a trouser leg. In this case, the line which represents centre "O" on your machine should be drawn in the centre of your paper instead of at the left hand edge in the same way as the KR7 owners do.

Use your Knitradar rulers which have the "O" in the centre when knitting this type of pattern.

The second method for drawing shapes which are not symmetrical is used when the shape does not fit easily onto the width of the tracing paper. This will rarely happen to KR7 owners. In this case the line which represents centre "O" remains at the left hand edge. Draw half the shape onto the paper first, then draw the other half onto the same piece of paper but reversing the direction – as if you had folded the shape in half. See example 2.

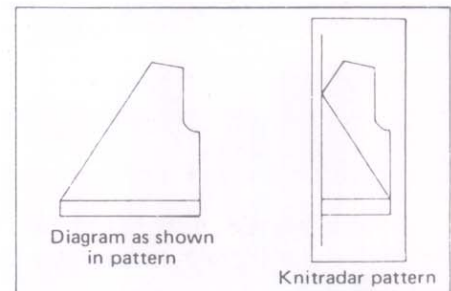

Example 2

When knitting, you must shape each edge of your knitting differently, according to the lines on your Knitradar pattern. The shape will be easier to follow if you draw one half in a different colour.

## A word for those who don't use Knitradar

If you haven't used your Knitradar yet, why not listen to the Knitmaster Knitradar Tuition Cassette. It will talk you step by step through knitting a garment using the Knitradar. You'll soon get the hang of it and wonder how you ever managed without Knitradar. The Knitradar allows you the freedom to choose your own yarn and stitch patterns and to make any alterations to the design you might fancy. Ask any of your friends who use Knitradar and they'll tell you how much you're missing by not using it.



# NEW

FOR 9mm CHUNKY  
MACHINES

## The *Kiddies Chunky* Book

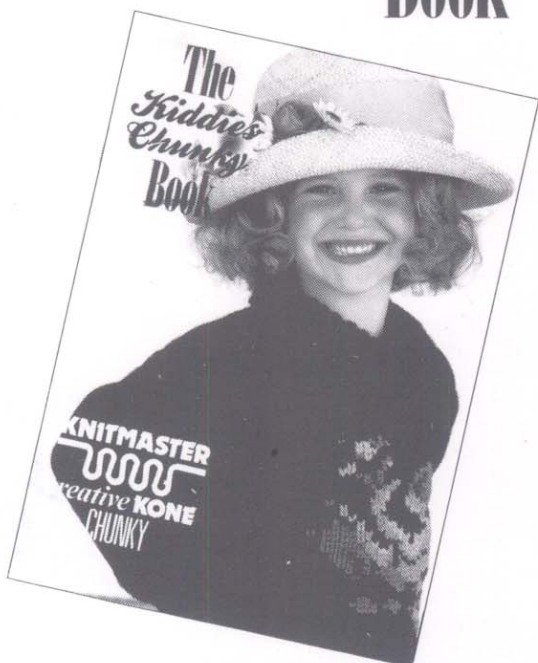

All in Knitmaster's superb new Kone Chunky  
A collection of 30 Chunky patterns for children

Includes classic cardigans and sweaters as well  
as fashion knits for boys and girls

Sizes 24"–30" chest

AVAILABLE FROM YOUR KNITMASTER STOCKIST

## KnitLink from **KNITMASTER**



# The All-Round Winner

Knitlink really is an all round winner. An electric circular linker is just what you need to take all the effort out of sewing up knitwear.

Join seams — attach collars and neckbands — you'll be amazed at the time you save — and the neat professional finish you'll achieve.



Knitlink is available from Knitmaster stockists now. Call in today and ask for a free demonstration.

## KNITMASTER'S KNITRADAR — THE ULTIMATE GRAPHIC PATTERN SYSTEM.

Add Knitmaster's knitradar to your machine — and make sure every garment you knit is a perfect fit.

Knitmaster's knitradar works from a diagram pattern — similar to a dressmaking pattern — which shows you exactly how many stitches to cast on, and where and when to increase and decrease.

You choose the yarn — the stitch pattern — the garment shape — and the knitradar does the rest.

Add the knitradar to any gauge of Knitmaster machine.

Ask your local Knitmaster stockist for a free demonstration today.

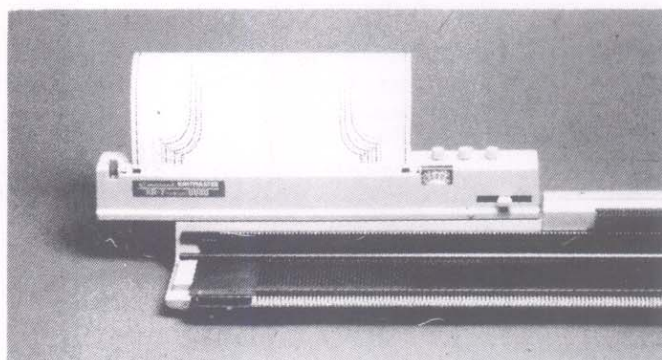

## KNITMASTER



# 10 ENGLISH RIB RAGLAN SWEATER



For Knitmaster 9mm Chunky Machines with Ribbing Attachment.

## Sizes:

To fit 81-86 (91-96) (101-106) (112-117) cms/32-34 (36-38) (40-42) (44-46) inch bust/chest.

## Materials:

Knitmaster Chunky  
Col 1 (Geranium) — 850 (950) (1050) (1150) grms

## Tensions:

English Rib — 16 sts and 31 rows to 10 cms. TD's at approx. 5 (MT)

1 × 1 Rib — 23 rows to 10 cms. TD's at approx. MT-4

## Pattern Note:

English Rib.

The classic English Rib sweater is one of these wonderful timeless designs which just seems to go on year after year. For this reason, this beautifully styled English Rib raglan sweater should prove to be one of your most useful patterns — knit it in any colour you fancy for many years to come.

## BACK

Arrange 71 (79) (87) (95) Ns for 1 × 1 rib. Using col 1, cast on. RC 000. MT-4, knit 19 rows. Cast off with waste yarn.

Push 40 (44) (48) (52) Ns at left and right of centre O to WP. 80 (88) (96) (104) Ns altog. With carr at right, pick up sts from below waste yarn and place onto Ns increasing evenly. Transfer alt sts to ribber. RC 000. MT. Using col 1, continue in English Rib. Knit 100 (106) (112) (118) rows. Carr at right.

Shape Raglan Armholes

Cast off 3 sts at beg of the next 2 rows\*\*.

### 1st Size Only

\*Knit 3 rows. Dec 1 st at both ends of the next and ev foll 3rd row 6 times in all\*. Rept the last 19 rows from \*to\* 3 more times.

### 2nd Size Only

Knit 2 rows. Dec 1 st at both ends of the next and ev foll 3rd row 4 times in all. \*Knit 3 rows. Dec 1 st at both ends of the next and ev foll alt row 3 times in all\*. Rept the last 8 rows from \*to\* 7 more times.

### 3rd Size Only

Knit 2 rows. Dec 1 st at both ends of the next and foll 3rd row. \*Knit 2 rows. Dec 1 st at both ends of the next and ev foll alt row 3 times in all\*. Rept the last 7 rows from \*to\* 9 more times.

### 4th Size Only

\*Knit 2 rows. Dec 1 st at both ends of

the next and ev foll alt row 9 times in all\*. Rept the last 19 rows from \*to\* 3 more times.

### All Sizes

Knit 1 row. Dec 1 st at both ends of the next and ev foll alt row 3 times in all. RC 184 (190) (196) (202). Cast off rem 20 sts.

## FRONT

Knit as for Back to \*\*.

### 1st Size Only

\*Knit 3 rows. Dec 1 st at both ends of the next and ev foll 3rd row 6 times in all\*. Rept the last 19 rows from \*to\* 2 more times. Knit 3 rows.

### 2nd Size Only

Knit 2 rows. Dec 1 st at both ends of the next and ev foll 3rd row 4 times in all. \*Knit 3 rows. Dec 1 st at both ends of the next and ev foll alt row 3 times in all\*. Rept the last 8 rows from \*to\* 5 more times.

### 3rd Size Only

Knit 2 rows. Dec 1 st at both ends of the next and foll 3rd row. \*Knit 2 rows. Dec 1 st at both ends of the next and ev foll alt row 3 times in all\*. Rept the last 7 rows from \*to\* 6 more times. Knit 2 rows. Dec 1 st at both ends of the next and foll alt row.

### 4th Size Only

\*Knit 2 rows. Dec 1 st at both ends of the next and ev foll alt row 9 times in all\*. Rept the last 19 rows from \*to\* 2 more times. Knit 2 rows. Dec 1 st at both ends of the next row.

### All Sizes

38 (38) (40) (42) sts. RC 162 (168) (174) (180). Carr at right.

## Shape Neck

Using a length of col 1, cast off centre 12 sts. Hold Ns at left.

Knit Right Part as Follows:—

### 1st Size Only

Dec 1 st at raglan edge of the next row. Dec 1 st at neck edge on the next row, knit 1 row. Dec 1 st at both ends of the next row, knit 1 row. Dec 1 st at neck edge of the next row. Rept the last 6 rows once more. Dec 1 st at raglan edge

of the next and foll 3rd row. fasten off rem st.

### 2nd Size Only

Knit 1 row. Dec 1 st at neck edge of the next row, knit 1 row. Dec 1 st at both ends of the next and ev foll alt row 3 times in all, knit 1 row. Dec 1 st at neck edge of the next row, knit 1 row. Dec 1 st at both ends of the next row, knit 1 row. Dec 1 st at raglan edge of the next and foll alt row. Fasten off rem st.

### 3rd Size Only

Knit 1 row. Dec 1 st at both ends of the next row, knit 1 row. \*Dec 1 st at neck edge of the next row. Dec 1 st at raglan edge of the next row\*. Rept the last 2 rows from \*to\* 2 more times. Dec 1 st at neck edge of the next row, knit 1 row. Dec 1 st at both ends of the next row, knit 1 row. Dec 1 st at raglan edge of the next and foll alt row. Fasten off rem st.

### 4th Size Only

Knit 1 row. Dec 1 st at both ends of the next and ev foll alt row 6 times in all, knit 1 row. Dec 1 st at raglan edge of the next and foll alt row. Fasten off rem st.

### All Sizes

Carr at right. Bring Ns back to WP. Knit left part as for right part.

## LEFT SLEEVE

Arrange 36 (37) (39) (40) Ns for 1 × 1 rib. Using col 1, cast on. RC 000. MT-4, knit 13 rows. Cast off with waste yarn. Push 21 (22) (23) (24) Ns at left and right of centre O to WP. 42 (44) (46) (48) Ns altog. With carr at right, pick up sts from below waste yarn and place onto Ns increasing evenly. Transfer alt sts to ribber. RC 000. MT. Using col 1. Continue in English Rib. Knit 4 rows. Inc 1 st at both ends of the next and ev foll 5th (5th) (6th) (6th) row 24 (23) (22) (21) times in all. 90 sts. Knit to Row 130 (134) (138) (140). Carr at right. (Knit 1 row extra for Right Sleeve only).

## Shape Raglan Top

Cast off 3 sts at beg of the next 2 rows.

Continued on page 28



**PATTERN 10**

Continued from page 26

**1st Size Only**

\*Dec 1 st at both ends of the next and foll alt row\*. Rept the last 3 rows from \*to\* 17 more times.

**2nd & 3rd Sizes Only**

\*Dec 1 st at both ends of the next and ev foll alt row (3) (6) times in all\*. Rept the last (5) (11) rows from \*to\* (11) (5) more times.

**4th Size Only**

Dec 1 st at both ends of the next and ev foll alt row 36 times in all, knit 1 row.

**All Sizes**

12 sts. Cast off 4 sts at beg and dec 1 st at end of next row, knit 1 row. Cast off 2 sts at beg and dec 1 st at end of the next row, knit 1 row. Dec 1 st at both ends of the next row. Dec 1 st at beg of the next row. Fasten off rem st.

**RIGHT SLEEVE**

Knit as for Left Sleeve but note alteration in number of rows worked.

**NECKBAND**

Arrange 77 Ns for 1 x 1 rib. Using col 1, cast on. RC 000. MT-4, knit 19 rows. Transfer sts to knitter. Knit 1 row MT. Cast off with waste yarn.

**TO MAKE UP**

Pin out to size and steam carefully. Join raglan, side and sleeve seams. Back-stitch neckband into pos and join centre back seam. Fold in half and catch down on the inside. Give final light steam.

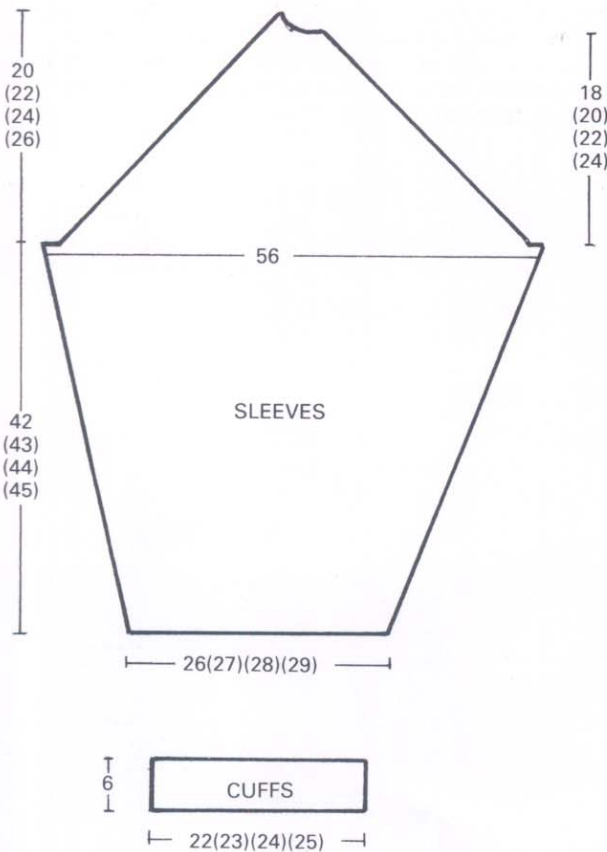
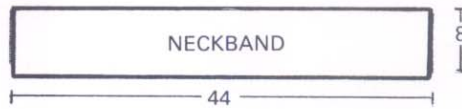
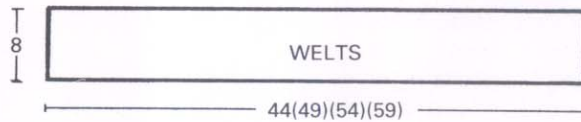
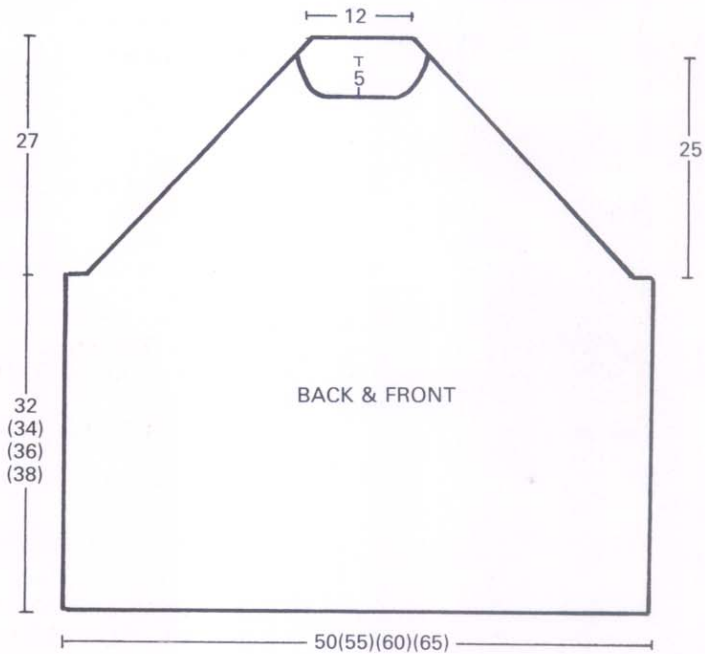

**ABBREVIATIONS**

Alt	— Alternate
Altog	— Altogether
Approx	— Approximately
Beg	— Beginning
Carr	— Carriage
Cm(s)	— Centimetre(s)
Dec	— Decrease
Ev	— Every
Foll	— Following
HP	— Holding Position
Inc	— Increase
MT	— Main Tension
N	— Needle
Ns	— Needles
NWP	— Non Working Position
Patt	— Pattern
Pos	— Position
Rept	— Repeat
Rem	— Remaining
RC	— Row Counter
St	— Stitch
Sts	— Stitches
TD	— Tension Dial
Tog	— Together
UWP	— Upper Working Position
WP	— Working Position

# 11 RIBBY SWEATER WITH SWISS DARNING



For Knitmaster 9mm Chunky Machines.

## Sizes:

To fit 81-86 (91-96) (101-106) (112-117) cms/32-34 (36-38) (40-42) (44-46) inch bust/chest.

## Materials:

Knitmaster Chunky  
Col 1 (Bluebell or Midnight) — 680 (705) (730) (755) grms  
Col 2 (Oatmeal) — 45 (50) (55) (60) grms  
Col 3 (Midnight or Bluebell) — small amount  
Col 4 (Serpentine) — small amount

## Tensions:

Pattern — 15 sts and 21 rows to 10 cms. TD at approx. 7 (MT)  
Knit 1 Purl 1 Rib — 27 rows to 10 cms. TD at approx. MT-6

## Pattern Note:

\*Knit 2 rows col 2. Counting from both sides of centre O, push the 2nd & 3rd and ev foll 3rd and 4th N to HP. Set rassel levers to I. Knit 2 rows col 1. Set rassel levers to II. Knit 2 rows col 2\*.

Tuck Lace Pattern — follow chart.

An unusual handworked tuck lace pattern has been used on these sweaters to create vertical stripes of texture. The tuck lace charts on page 33 give instructions for producing this unusual fabric. Why not try knitting a small sample piece to familiarise yourself with the technique — you never know when you might like to introduce these textured stripes into another design.

## BACK

Push 66 (74) (81) (89) Ns to WP. Cast on as given in additional notes for Knit 1 Purl 1 Rib. RC 000. MT-6, knit 16 rows. Drop the 3rd and ev foll alt st and pick up as for Knit 1 Purl 1 Rib. Cast off with waste yarn. Push 37 (41) (45) (49) Ns at left and right of centre O to WP. 74 (82) (90) (98) Ns altog. With carr at right, pick up sts from below waste yarn and place onto Ns increasing evenly. RC 000. MT. Using col 1, knit 5 rows. Knit 6 rows given in pattern note from \*to\*. Continue in tuck lace pattern following chart. Knit 51 (51) (55) (55) rows. RC 62 (62) (66) (66). Mark both ends with waste yarn\*\*. Knit 58 rows. RC 120 (120) (124) (124). Carr at right.

## Shape Back Neck

Using a length of col 1, cast off centre 18 sts. Hold Ns at left.

## Knit Right Part as Follows:—

Knit 1 row. Cast off 3 sts at beg of the next row, knit 1 row. Cast off 2 sts at beg of the next row. Cast off rem 23 (27) (31) (35) sts. Take carr to left. Bring Ns back to WP. Knit left part as for right part.

## FRONT

Knit as for Back to \*\*. Knit 42 rows. RC 104 (104) (108) (108). Carr at right.

## Shape Neck

Using a length of col 1, cast off centre 16 sts. Hold Ns at left.

## Knit Right Part as Follows:—

Knit 1 row. Cast off 2 sts at beg of the

next row, knit 1 row. Dec 1 st at neck edge on the next and foll alt row, knit 3 rows. Dec 1 st at neck edge on the next and foll 4th row, knit 6 rows. Cast off rem 23 (27) (31) (35) sts. Take carr to left. Bring Ns back to WP. Knit left part as for right part.

## SLEEVES

Push 33 Ns to WP. Cast on as given in additional notes for Knit 1 Purl 1 Rib. RC 000. MT-6, knit 16 rows. Drop the 3rd and ev foll alt st and pick up as for Knit 1 Purl 1 Rib. Cast off with waste yarn. Push 21 Ns at left and right of centre O to WP. 42 Ns altog. Pick up sts from below waste yarn and place onto Ns increasing evenly. RC 000. MT. Knit 1 row, inc 1 st at both ends of the next and ev foll 4th row 24 times in all, AT THE SAME TIME knit 5 rows stockinet col 1, 6 rows as given in pattern note from \*to\* then continue in tuck lace

pattern following chart. 90 sts. Knit to Row 105. Mark centre with waste yarn. Cast off.

## NECKBAND

Push 81 Ns to WP. Cast on as given in additional notes for Knit 1 Purl 1 Rib. RC 000. MT-6, knit 32 rows. Drop the 3rd and ev foll alt st and pick up as for Knit 1 Purl 1 Rib. Knit 1 row MT. Cast off with waste yarn.

## TO MAKE UP

Pin out to size and steam carefully. Swiss darn pieces following appropriate chart and position swiss darning as shown in photograph. Join shoulder seams. Set in sleeves between marked points. Join side and sleeve seams. Backstitch neckband into pos and join centre back neck seam. Fold in half and catch down on the inside. Give final light steam.

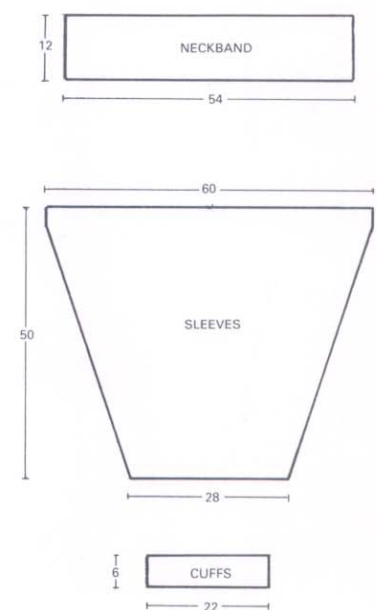
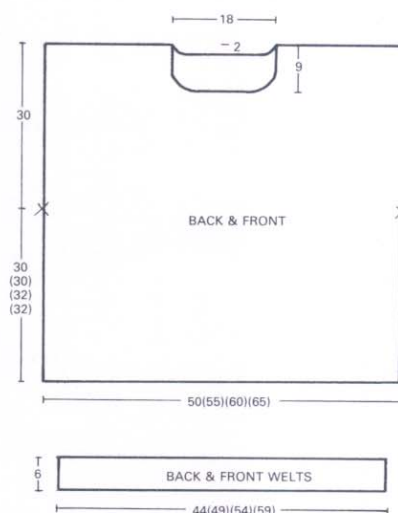

Continued on page 33



12



# 12 ARAN CREW NECK CARDIGAN



For Knitmaster 9mm Chunky Machines.

### Sizes:

To fit 81-86 (91-96) (101-106) (112-117) cms/32-34 (36-38) (40-42) (44-46) inch bust/chest

### Materials:

Knitmaster Chunky  
Col 1 (Aran) — 670 (720) (770) (820) grms  
13 buttons

### Tensions:

Pattern — 16 sts and 21 rows to 10 cms. TD at approx. 7 (MT)  
Knit 1 Purl 1 Rib — 14 sts and 27 rows to 10 cms. TD at approx. MT-6

### Pattern Note:

Cable & Garter Stitch — see chart.

**Garter stitch and cables placed in different positions and at different intervals give this cardigan a heavily textured Aran look. Notice how always crossing the cable stitches in the same direction produces a different effect from crossing them in the opposite direction each time. There are many different cable variations — why not start collecting different examples for your future reference.**

### BACK

Push 70 (78) (86) (94) Ns to WP. Cast on as given in additional notes for Knit 1 Purl 1 Rib. RC 000. MT-6, knit 20 rows. Drop the 3rd and ev foll alt st and pick up as for Knit 1 Purl 1 Rib. Cast off with waste yarn. Push 40 (44) (48) (52) Ns at left and right of centre O to WP. 80 (88) (96) (104) Ns altog. With carr at right, pick up sts from below waste yarn and place onto Ns increasing evenly. RC 000. MT. Continue in pattern following chart. Knit 65 (65) (69) (69) rows. Mark both ends with waste yarn. Knit 53 rows. RC 118 (118) (122) (122). Carr at right.

### Shape Back Neck

Note pos in pattern. Using a length of col 1, cast off centre 16 sts. Hold Ns at left.

### Knit Right Part as Follows:—

Knit 1 row. Cast off 3 sts at beg of the next row, knit 1 row. Cast off 2 sts at beg of the next row. Cast off rem 27 (31) (35) (39) sts. Take carr to left. Bring Ns back to WP. Knit left part as for right part.

### RIGHT FRONT

Push 35 (39) (43) (47) Ns to WP. Cast on as given in additional notes for Knit 1 Purl 1 Rib. RC 000. MT-6, knit 20 rows. Drop the 3rd and ev foll alt st and pick up as for Knit 1 Purl 1 Rib. Cast off with waste yarn. Push 40 (44) (48) (52) Ns at right of centre O to WP. With carr at

right, pick up sts from below waste yarn and place onto Ns increasingly evenly. RC 000. MT. Continue in pattern following chart. Knit 65 (65) (69) (69) rows. Mark right edge with waste yarn. Knit 40 rows. RC 105 (105) (109) (109). Carr at left.

### Shape Neck

Cast off 5 sts at beg of the next row, knit 1 row. Cast off 3 sts at beg of the next row, knit 1 row. Cast off 2 sts at beg of the next row, knit 1 row. Dec 1 st at beg of the next and ev foll alt row 3 times in all, knit 6 rows. Cast off rem 27 (31) (35) (39) sts.

### LEFT FRONT

Knit as for Right Front but in reverse.

### SLEEVES

Push 32 Ns to WP. Cast on as given in additional notes for Knit 1 Purl 1 Rib. RC 000. MT-6, knit 20 rows. Drop the 3rd and ev foll alt st and pick up as for Knit 1 Purl 1 rib. Cast off with waste yarn. Push 21 Ns at left and right of centre O to WP. 42 Ns altog. Pick up sts from below waste yarn and place onto Ns increasing evenly. RC 000. MT. Continue in

pattern following chart. Knit 2 rows. Inc 1 st at both ends of the next and ev foll 4th row 22 times in all. 86 sts. Knit to Row 92 (92) (94) (94). Mark centre with waste yarn. Cast off.

### NECKBAND

Push 67 Ns to WP. Cast on as given in additional notes for Knit 1 Purl 1 Rib. RC 000. MT-6, knit 20 rows. Drop the 3rd and ev foll alt st and pick up as for Knit 1 Purl 1 Rib. Knit 1 row MT. Cast off with waste yarn.

### BUTTONHOLE BAND

Push 87 (87) (90) (90) Ns to WP. Cast on as given in additional notes for Knit 1 Purl 1 Rib. RC 000. MT-6, knit 5 rows. Drop the 3rd and ev foll alt st and pick up as for Knit 1 Purl 1 Rib. Make 13 evenly spaced buttonholes over 1 N. Knit 5 rows. Drop the 3rd and ev foll alt st and pick up as for Knit 1 Purl 1 Rib. Knit 1 row MT. Cast off with waste yarn.

### BUTTON BAND

Knit as for Buttonhole Band but omit buttonholes.

### CABLE CHART

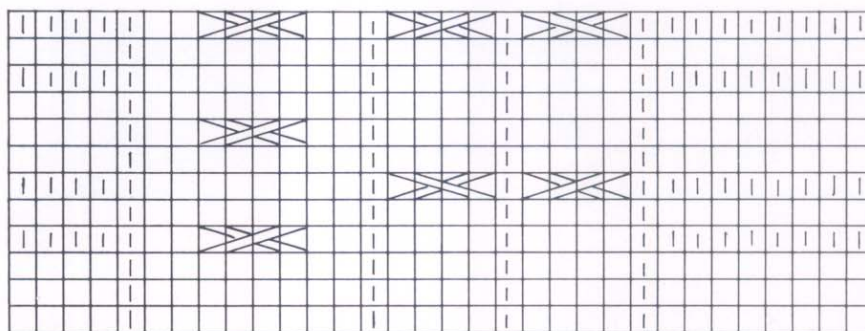

Repeat to end

| = drop st & reform as for ribbing

= cross 2 sts at left over 2 sts at right



**TO MAKE UP**

Pin out to size and steam carefully. Join shoulder seams. Set in sleeves between

marked points. Join side and sleeve seams. Backstitch neckband into pos, fold in half and catch down on the

inside. Backstitch front bands into pos. Sew on buttons to correspond with buttonholes. Give final light steam.

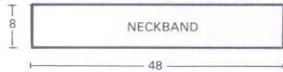
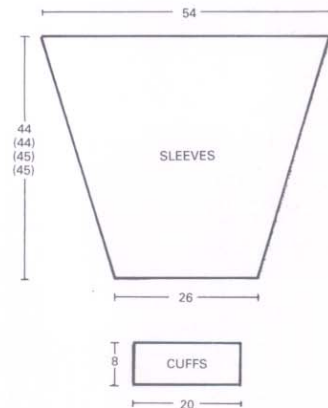
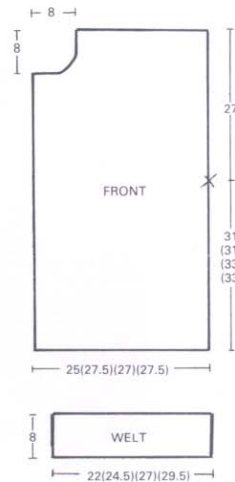
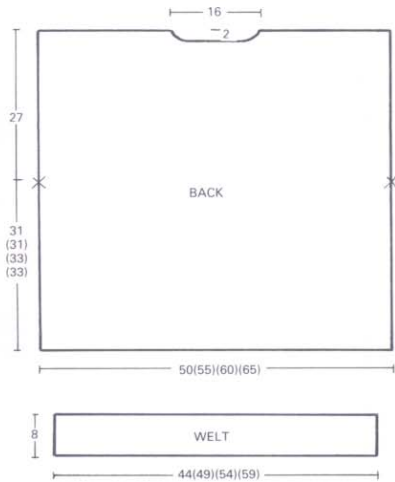

**PATTERN 11**

Continued from page 29

**SWISS DARNING CHARTS**

**LADIES SWEATER**

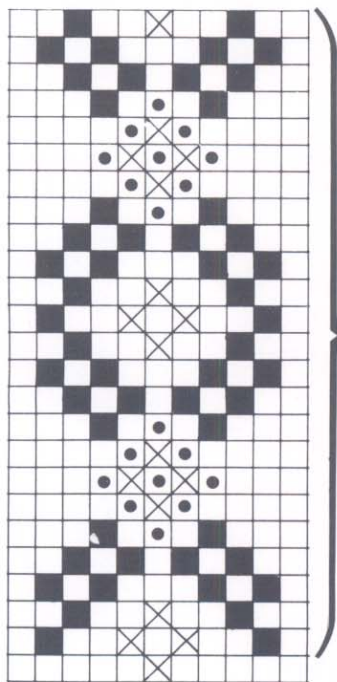

**MAN'S SWEATER**

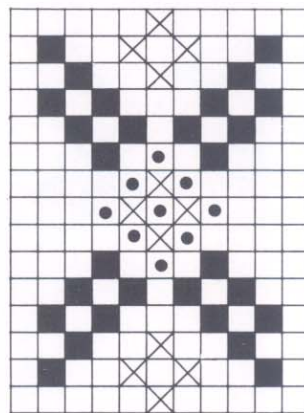

**KEY**

- Col 2
- ⊗ Col 3
- Col 4

Repeat



**TUCK LACE**

Drop the first pattern stitch and reform from the front of the knitting, picking up every second row. Drop the second pattern stitch and reform in the same way as before but picking up the alternate rows which were missed when reforming the first stitch.

**TUCK LACE CHARTS**

**LADIES SWEATER SLEEVES**

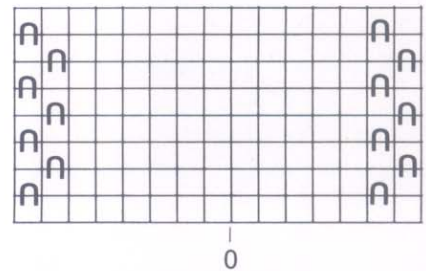

**MANS SWEATER — BACK, FRONT & SLEEVES**

**LADIES SWEATER — BACK & FRONT**

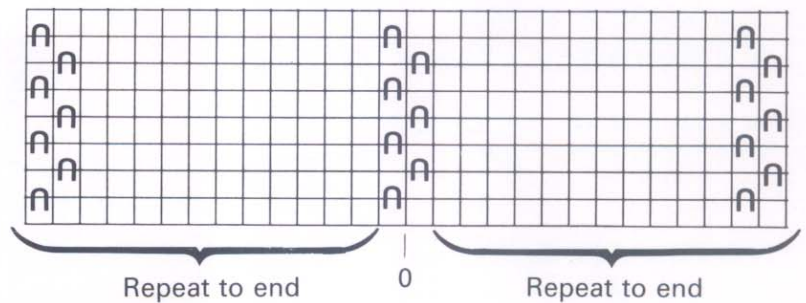

13

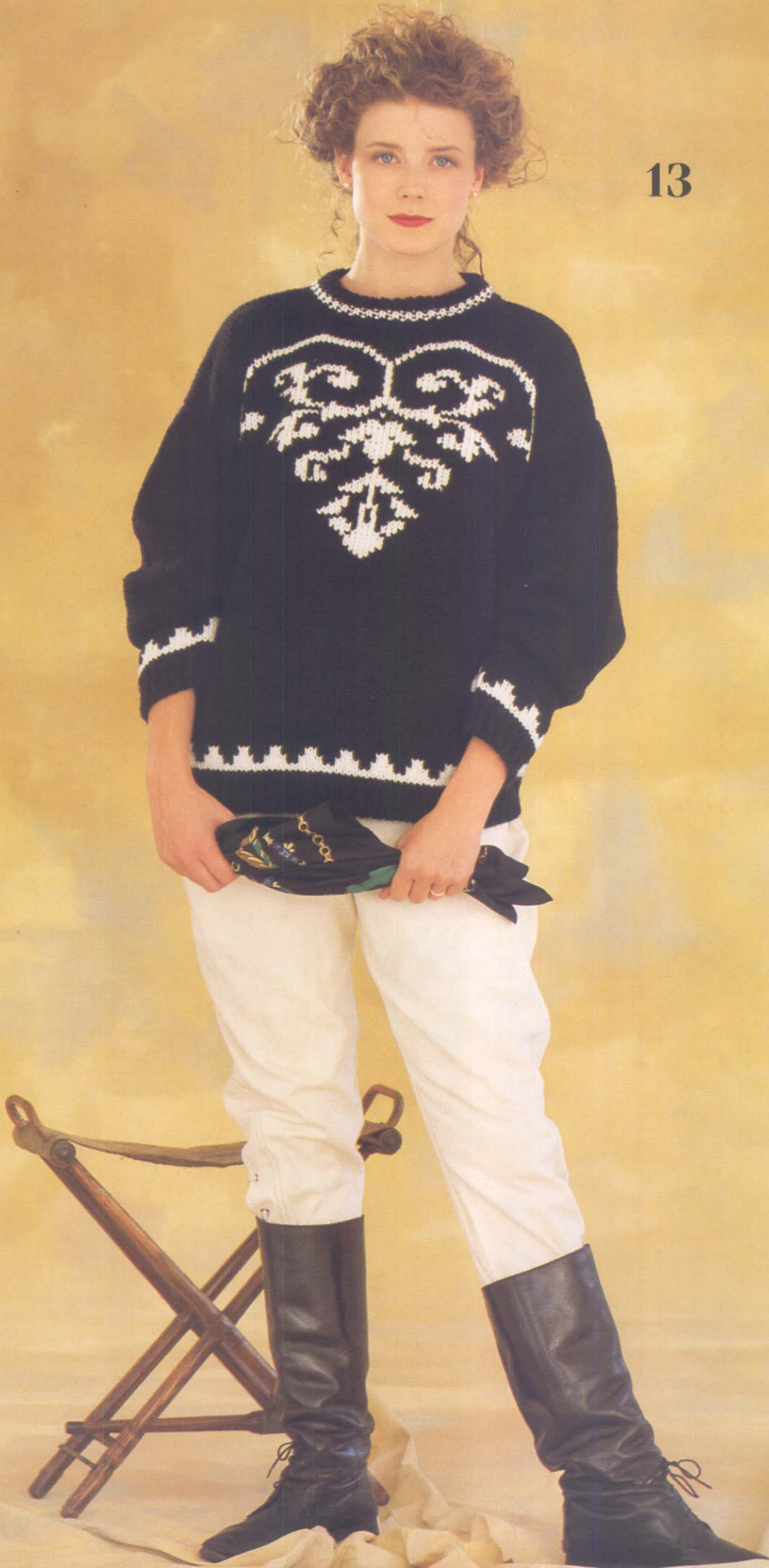

# 13 BLACK & WHITE INTARSIA SWEATER

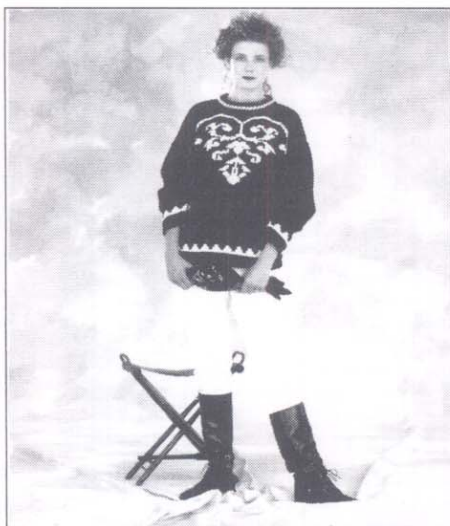

For Knitmaster 9mm Chunky Machines with Intarsia Carriage.

### Sizes:

To fit 81-86 (91-96) (101-106) (112-117) cms/32-34 (36-38) (40-42) (44-46) inch bust/chest

### Materials:

Knitmaster Chunky  
Col 1 (Black) — 680 (730) (780) (830) grms  
Col 2 (White) — 60 (70) (80) (90) grms

### Tensions:

Stockinet & Intarsia — 15 sts and 22 rows to 10 cms. TD at approx. 6 (MT)  
Knit 1 Purl 1 Rib — 27 rows to 10 cms. TD at approx. MT-5

### Pattern Note:

Intarsia pattern follow charts.

If your machine doesn't knit Intarsia and you haven't got round to buying an intarsia carriage yet, you can, in the meantime, knit this sweater plain. Alternatively, Swiss Darn the intarsia design or simply introduce a border of the 2 colour tuck pattern from pattern 11. Maybe even embroider it with one or two of the flowers from pattern 9.

### BACK

Push 63 (71) (78) (85) Ns to WP. Cast on as given in additional notes for Knit 1 Purl 1 Rib. RC 000. MT-5, knit 10 rows. Drop the 3rd and ev foll alt st and pick up as for Knit 1 Purl 1 Rib. Cast off with waste yarn. Push 37 (41) (45) (49) Ns at left and right of centre O to WP. 74 (82) (90) (98) Ns altog. With carr at right, pick up sts from below waste yarn and place onto Ns increasing evenly. RC 000. MT. Following chart A, knit 6 rows intarsia. Continue in stockinet col 1\*. Knit 60 (60) (64) (64) rows. RC 66 (66) (70) (70). Mark both ends with waste yarn. Knit 58 rows. RC 124 (124) (128) (128). Carr at right.

### Shape Back Neck

Using a length of col 1, cast off centre 18 sts. Hold Ns at left.  
Knit Right Part as Follows:—  
Knit 1 row. Cast off 2 sts beg next and foll alt row. Cast off rem 24 (28) (32) (36) sts. Take carr to left. Bring Ns back to WP. Knit left part as for right part.

### FRONT

Knit as for Back to \*. Knit 44 (44) (49) (49) rows. RC 50 (50) (55) (55). Following chart B continue in intarsia pattern. Knit 16 (16) (15) (15) rows. RC 66 (66) (70) (70). Mark both ends with waste yarn. Knit 41 (41) (42) (42) rows (end of intarsia pattern). Continue in stockinet

col 1. Knit 5 (5) (4) (4) rows. RC 112 (112) (116) (116). Carr at right.

### Shape Neck

Using a length of col 1, cast off centre 16 sts. Hold Ns at left.

### Knit Right Part as Follows:—

Knit 1 row. Cast off 2 sts beg of the next row, knit 1 row. Dec 1 st at neck edge on the next and ev foll 3rd row 3 times in all, knit 6 rows. Cast off rem 24 (28) (32) (36) sts. Take carr to left. Bring Ns back to WP. Knit left part as for right part.

### SLEEVES

Push 36 Ns to WP. Cast on as given in additional notes for Knit 1 Purl 1 Rib. RC 000. MT-5, knit 10 rows. Drop the 3rd and ev foll alt st and pick up as for Knit 1 Purl 1 Rib. Cast off with waste yarn. Push 23 Ns at left and right of centre O to WP. 46 Ns altog. Pick up sts from below waste yarn and place onto Ns increasing evenly. RC 000. MT. Following chart A knit 6 rows intarsia pattern then continue in stockinet col 1, AT THE

SAME TIME knit 2 rows. Inc 1 st at both ends of the next and ev foll 5th row 8 times in all, knit 5 rows. Inc 1 st at both ends of the next and ev foll 6th row 11 times in all. 84 sts. Knit to Row 106. Mark centre with waste yarn. Cast off.

### NECKBAND

Push 75 Ns to WP. Cast on as given in additional notes for Knit 1 Purl 1 Rib. RC 000. MT-5, knit 14 rows. Using col 2, knit 2 rows. Drop the 3rd and ev foll alt st and pick up as for Knit 1 Purl 1 Rib. Knit 1 row MT col 2. Cast off with waste yarn.

### TO MAKE UP

Pin out to size and steam carefully. Join shoulder seams. Set in sleeves between marked points. Join side and sleeve seams. Backstitch neckband into pos and join centre back neck seam. Fold in half and catch down on the inside. Give final light steam.

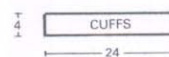
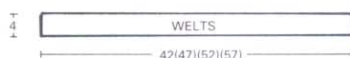
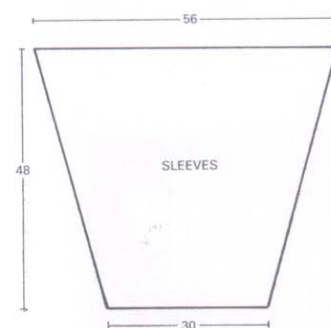
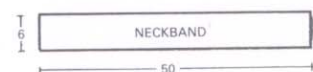
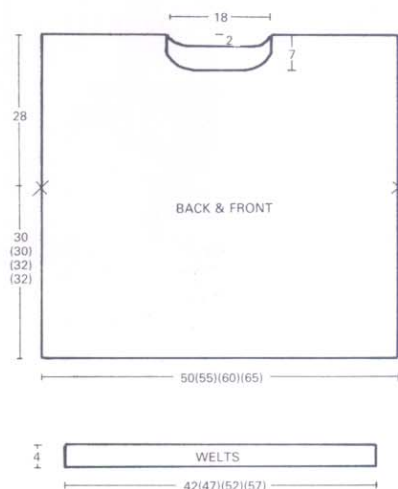

CHART A

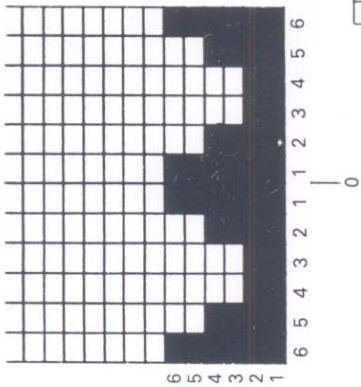
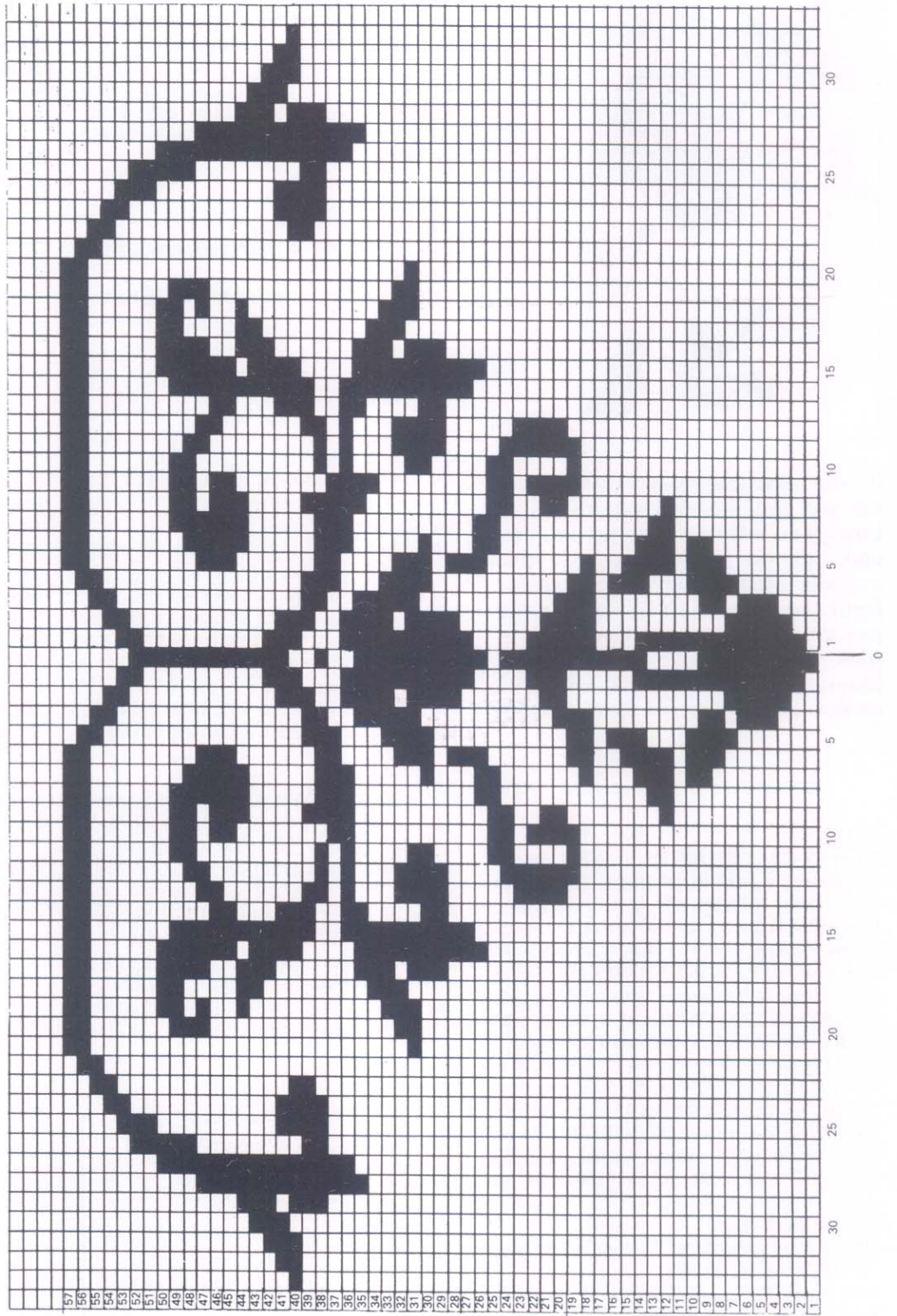

CHART B



# 14 TRADITIONAL FAIR ISLE SWEATER



If you look at the Pattern Note for this design, you'll see that the colour sequence is quite lengthy. To make it easier to follow while you're knitting, mark the colours onto the punchcard. Do this while the punchcard is in the pattern panel and you won't have to worry about taking into account rows which are inside the pattern panel.

## BACK

Push 66 (74) (81) Ns to WP. Cast on as given in additional notes for Knit 1 Purl 1 Rib. RC 000. MT-5, knit 16 rows. Drop the 3rd and ev foll alt st and pick up as for Knit 1 Purl 1 Rib. Cast off with waste yarn. Push 39 (43) (47) Ns at left and right of centre O to WP. 78 (86) (94) Ns altog. With carr at right, pick up sts from below waste yarn and place onto Ns increasing evenly. Insert card into machine and lock on row 1. RC 000. MT. Using col 1, knit 4 rows stockinet. Release card. Set carr for Fair Isle. Knit 33 rows given in pattern note. Remove card. Continue in stockinet col 1. Knit 33 (35) (37) rows. RC 70 (72) (74). Carr at right.

## Shape Armholes

Cast off 7 sts at beg of the next 2 rows. 64 (72) (80) sts\*. Knit 54 rows. Carr at right.

## Shape Back Neck

Using a length of col 1, cast off centre 16 sts. Hold Ns at left.

## Knit Right Part as Follows:—

Knit 1 row. Cast off 3 sts at beg of the next row.

## Shaper Shoulder

Cast off 9 (11) (13) sts at beg of the next row, 3 sts at beg of the next row. Cast off rem 9 (11) (13) sts. Take carr at left. Bring Ns back to WP. Knit left part as for right part.

For Knitmaster 9mm Chunky Punchcard Machines.

## Sizes:

To fit 81-86 (91-96) (101-106) cms/32-34 (36-38) (40-42) inch bust/chest.

## Materials:

Knitmaster Chunky

Col 1 (Opal) — 540 (590) (640) grms

Col 2 (Oatmeal) — 60 (70) (80) grms

Col 3 (Fashion Flip) — 40 (45) (50) grms

## Tensions:

Stockinet — 15 sts and 22 rows to 10 cms. TD at approx. 6 (MT)

Fair Isle — 15 sts and 20 rows to 10 cms. TD at approx. MT+1

Knit 1 Purl 1 Rib — 27 rows to 10 cms. TD at approx. MT-5

## Pattern Note:

Fair Isle — see punchcard chart.

Back, Front and Sleeves

\*Col 1 in feeder 1, Col 3 in feeder 2, knit 1 row.

Col 1 in feeder 1, Col 2 in feeder 2, knit 2 rows.

Col 1 in feeder 1, Col 3 in feeder 2, knit 1 row\*.

Col 1 only, knit 2 rows.

Col 3 only, knit 1 row.

Col 1 only, knit 2 rows.

Col 1 in feeder 1, Col 2 in feeder 2, knit 5 rows.

Col 3 in feeder 1, Col 2 in feeder 2, knit 2 rows.

Col 3 in feeder 1, Col 1 in feeder 2, knit 1 row.

Col 3 in feeder 1, Col 2 in feeder 2, knit 5 rows.

Col 1 only, knit 2 rows.

Col 3 only, knit 1 row.

Col 1 only, knit 2 rows.

Col 1 in feeder 1, Col 3 in feeder 2, knit 1 row.

Col 1 in feeder 1, Col 2 in feeder 2, knit 2 rows.

Col 1 in feeder 1, Col 3 in feeder 2, knit 1 row.

Sleeve head and Neckband

Rept from \*to\* once only.

## FRONT

Knit as for Back to \*. Knit 40 rows. Carr at right.

## Shape Neck

Using a length of col 1, cast off centre 14 sts. Hold Ns at left.

## Knit Right Part as Follows:—

Knit 1 row. Cast off 3 sts at beg of the next row, knit 1 row. Cast off 2 sts at beg of the next row, knit 1 row. Dec 1 st at beg of the next and foll alt row, knit 8 rows. Carr at right.

## Shape Shoulder

Cast off 9 (11) (13) sts at beg of the next row, knit 1 row, cast off rem 9 (11) (13) sts. Take carr to left. Bring Ns back to WP. Knit left part as for right part.

## SLEEVES

Push 30 Ns to WP. Cast on as given in additional notes for Knit 1 Purl 1 Rib. RC 000. MT-5, knit 16 rows. Drop the 3rd and ev foll alt st and pick up as for Knit 1 Purl 1 Rib. Cast off with waste yarn. Push 21 Ns at left and right of centre O to WP. 42 Ns altog. With carr at right, pick up sts from below waste yarn and place onto Ns increasing evenly. Insert card into machine and lock on row 1. RC 000. MT. Knit 4 rows stockinet col 1. Release card. Set carr for Fair Isle. Continue in Fair Isle pattern given in pattern note, knit 1 row. Inc 1 st at both ends of the next and ev foll 5th row 7 times in all, knit 1 row. RC 37. Reset card to Row 1 and lock. Continue in stockinet col 1. Knit 3 rows. Inc 1 st at both ends of the next and ev foll 5th row 10 (10) (11) times in all, knit 1 (3) (0) rows. RC 87 (89) (91). Mark both ends with waste yarn. Release card. Set carr for Fair Isle. Continue in Fair Isle pattern given in

pattern note from \*to\* and knit 3 (2) (4) rows.

## 1st & 2nd Sizes Only

Inc 1 st at both ends of the next row, knit 0 (1) row.

## All Sizes

Reset card to Row 1 and lock. Continue in stockinet col 1. Knit 6 rows. RC 97 (99) (101). Cast off 9 sts at beg of the next 8 rows. Mark centre with waste yarn. Cast off rem 6 sts.

## NECKBAND

Push 78 Ns to WP. Cast on as given in additional notes for Knit 1 Purl 1 Rib. RC 000. MT-5, knit 20 rows. Drop the 3rd and ev foll alt st and pick up as for Knit 1 Purl 1 Rib. Knit 1 row MT. Release card. Set carr for Fair Isle. Continue in Fair Isle pattern given in pattern note from \*to\*. Knit 1 row stockinet col 1. Cast off with waste yarn.

## TO MAKE UP

Pin out to size and steam carefully. Join shoulder seams. Set in sleeves sewing rows above marker to cast off sts at armhole. Join side and sleeve seams. Backstitch neckband into pos and join centre back neck seam. Fold rib in half onto the inside and catch down into pos. Give final light steam.

PUNCHCARD CHART

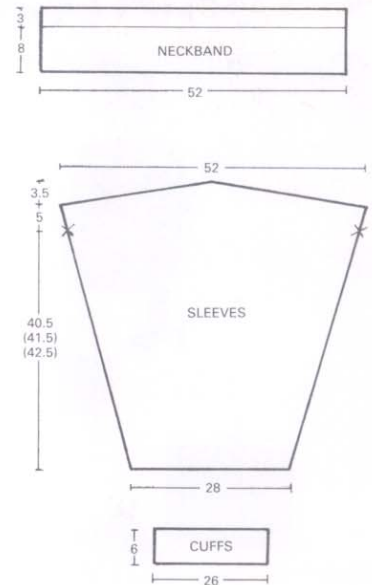
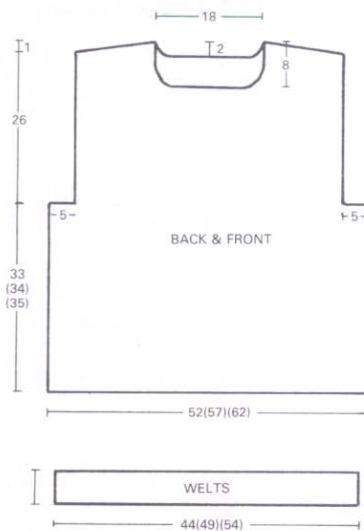
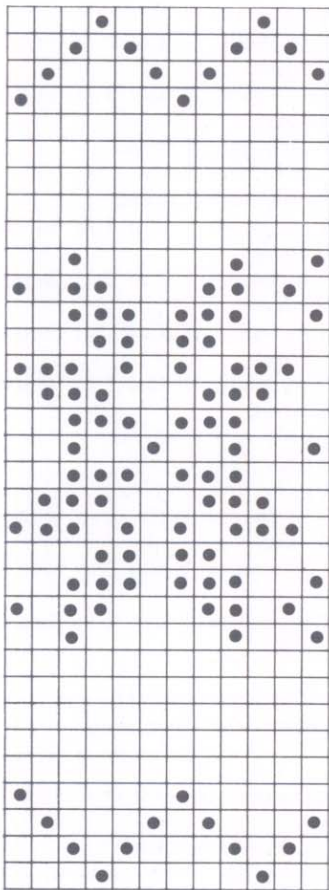

Don't *YOU* deserve **KNITMASTER'S** amazing MasterGlide 700?

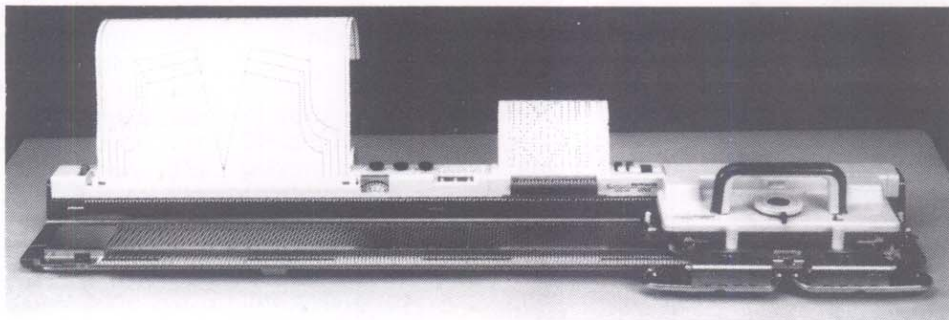

Wonderful knitwear starts with wonderful machines. If you want the best knitwear, you deserve one of the best machines. Complement your Chunky machine with a superb Knitmaster Standard Gauge, punchcard machine. Knitmaster's Master Glide 700 knits all those lovely finer yarns — 2ply, 3ply, 4ply Plain and fancy yarns. Knitmaster's Master Glide 700 knits an incredible range of stitch patterns — stocking stitch, Fair Isle, tuck and slip stitch, weaving, plating, single motif and intarsia. Add Knitmaster's unique single action transfer lace carriage for the prettiest lace imaginable. Knitmaster's 700 features Master Glide roller bearings to make your knitting flow like a dream.

You deserve a Knitmaster MasterGlide 700 machine — there's one waiting for you at your local Knitmaster stockist now.



# 15 PEPLUM CARDIGAN



Here's an extremely up-to-the-minute style for those of you who like to keep one step ahead of fashion. There's most definitely a 40's feel to much of this season's fashion and this little peplum cardigan successfully reflects it. The hand transfer lace pattern is quick and easy to do and can be used to decorate other designs too.

## BACK

Push 39 (43) (47) Ns at left and right of centre O to WP. 78 (86) (94) Ns altog. Using waste yarn, cast on. Mark the 26th st at left and right of centre O. Push Ns to HP. Carr at right. Using col 1, cast on by hand. Push Ns to UWP. RC 000. MT. Knit 13 (13) (15) rows. Mark both ends with waste yarn. Knit 13 rows. Knit 1 row marking the row by using sewing cotton in feeder 1 with main yarn. Using col 1 only\* knit 41 rows. RC 68 (68) (70). Counting from right of centre O, drop the 1st and ev foll alt st back to row previously marked and pick up as for ribbing. Counting from the left of centre O, drop the 2nd and ev foll alt st back to row previously marked and pick up as for ribbing.

## Shape Back Neck

Using a length of col 1, cast off centre 16 sts. Hold Ns at left.

Knit Right Part as Follows:—

Knit 1 row, cast off 6 sts at beg of the next row. Drop appropriate sts 2 rows back and pick up as for ribbing. Cast off rem 25 (29) (33) sts. Take carr to left. Bring Ns back to WP. Knit left part as for right part.

## RIGHT FRONT

Push 39 (43) (47) Ns at right to WP. Knit as for Back to \* but mark right edge only. Knit 26 rows. RC 53 (53) (55). Carr at left. Counting from the right of centre O, drop the 1st and ev foll alt st back to

For Knitmaster 9mm Chunky Machines.

## Sizes:

To fit 81-86 (91-96) (101-106) cms/32-34 (36-38) (40-42) inch bust

## Materials:

Knitmaster Chunky  
Col 1 (Capri) — 560 (610) (660) grms  
6 buttons

## Tensions:

Stockinet — 15 sts and 22 rows to 10 cms. TD at approx. 6 (MT)

Knit 1 Purl 1 Rib — 27 rows to 10 cms. TD at approx. MT-5

## Pattern Note:

Lace Pattern — Follow chart.

row previously marked and pick up as for ribbing.

## Shape Neck

Continue to drop and reform appropriate sts as for ribbing, cast off 7 sts at beg of the next row, knit 1 row. Cast off 3 sts at beg of the next row, knit 1 row. Cast off 2 sts at beg of the next row, knit 1 row. Dec 1 st at beg of the next and foll alt row, knit 8 rows. Cast off rem 25 (29) (33) sts.

## LEFT FRONT

Knit as for Right Front but in reverse and drop the 2nd and ev foll alt st at left of centre O when ribbing.

## FRILLS (knit 3)

Push 39 (43) (47) Ns at left and right of centre O to WP. 78 (86) (94) Ns altog. Using col 1, cast on. RC 000. MT. Continue in transfer lace pattern following chart, knit 18 rows. Knit 1 row stockinet. Counting from the right edge, push ev 4th N to HP, tuck 2 rows. Push Ns to UWP. MT+4, knit 1 row. Cast off with a latch tool.

## SLEEVES

Push 30 Ns to WP. Cast on as given in additional notes for Knit 1 Purl 1 Rib. RC 000. MT-5, knit 10 rows. Drop the 3rd and ev foll alt st and pick up as for Knit 1 Purl 1 Rib. Cast off with waste yarn. Push 21 Ns at left and right of centre O to WP. 42 Ns altog. With carr at right, pick up sts from below waste yarn and place onto Ns increasing evenly. RC 000. MT. Knit 5 rows. Inc 1 st at both ends of the next and ev foll 5th row 10 times in all, knit 5 rows. Inc 1 st at both ends of the next and foll 6th row, knit 4 rows. Knit 1 row marking the row by using sewing cotton in feeder 1 with main yarn. Using col 1 only, inc 1 st at both ends of the next and ev foll 6th row 6 times in all. 78 sts. Knit to Row 102. Counting from the right of centre O, drop the 1st and ev foll alt st and pick up as for ribbing. Counting from the left of

centre O, drop the 2nd and ev foll alt st and pick up as for ribbing. Mark centre with waste yarn. Cast off.

## BUTTONHOLE BAND

Push 18 (18) (19) Ns at left and right of centre O to WP. 36 (36) (38) Ns altog. Cast on as given in additional notes for Knit 1 Purl 1 Rib. RC 000. MT-5, knit 4 rows. Drop the 3rd and ev foll alt st and pick up as for Knit 1 Purl 1 Rib. Counting from the left edge make buttonholes over Ns 2 (2) (3); 5 (5) (6); 18 (18) (19); 21 (21) (22) and 34 (34) (35). Knit 4 rows. Drop the 3rd and ev foll alt st and pick up as for Knit 1 Purl 1 Rib. Knit 1 row MT. Cast off with waste yarn. Knit Button Band in the same way but omit buttonholes.

## NECKBAND

Arrange 84 Ns for Knit 1 Purl 1 Rib. Cast on as given in additional notes for Knit 1 Purl 1 Rib. RC 000. MT-5, knit 4 rows. Drop the 3rd and ev foll alt st and pick up as for Knit 1 Purl 1 Rib. Counting from the right edge make a buttonhole over N 3, knit 10 rows. Drop the 3rd and ev foll alt st and pick up as for Knit 1 Purl 1 Rib. Make a buttonhole over same N as before, knit 4 rows. Drop the 3rd and ev foll alt st and pick up as for Knit 1 Purl 1 Rib. Knit 1 row MT. Cast off with waste yarn.

## TO MAKE UP

Pin out to size and steam carefully, pressing lower edge of frill into a scallop. Join shoulder seams. Set in sleeves between marked points. Join side and sleeve seams. Backstitch front bands into pos. Backstitch neckband into pos including along edge of front bands. Fold in half and catch down on the inside. Sew on buttons to correspond with buttonholes. Sew one frill between marked points on back. Sew remaining frills from marked points to front edges. Give final light steam.

Continued on page 42

14





15



**PATTERN 15**

Continued from page 39

LACE CHART

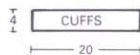
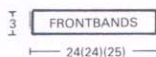
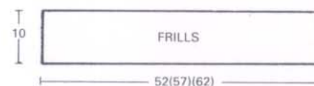
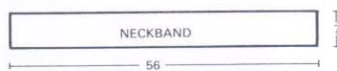
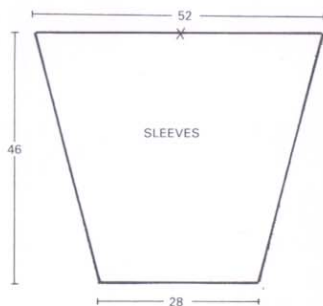
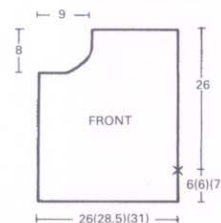
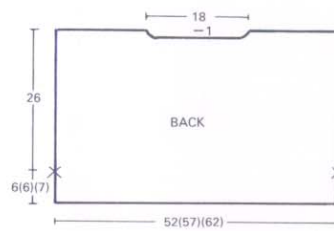
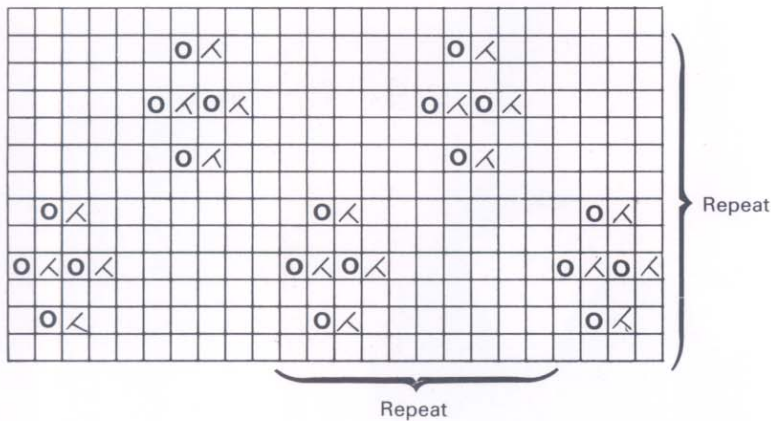

# INDEX

All the designs in this pattern book were knitted on Knitmaster 9mm Chunky machines using Knitmaster Chunky. The index below will help you to identify quickly the size range for each design, which Knitmaster Chunky machines each can be knitted on and which designs are suitable for both men and women.

MEN		Knitmaster Machine	Size Range	Page No
1.	Raglan V-neck Sweater	150, 151, 155 & Zippy 90	32"-46"	6
2.	Raglan V-neck Cardigan	150, 151, 155 & Zippy 90	32"-46"	6
3.	Raglan Crew Neck Sweater	150, 151, 155 & Zippy 90	32"-46"	6
4.	Raglan Crew Neck Cardigan	150, 151, 155 & Zippy 90	32"-46"	6
5.	Icelandic Sweater	155	32"-46"	10
6.	Icelandic Cardigan	155	32"-46"	10

		<b>Knitmaster Machine</b>	<b>Size Range</b>	<b>Page No</b>
8.	Aran Crew Neck Sweater	150, 151, 155 Zippy 90	32"-46" 32"-42"	16 16
10.	English Rib Raglan Sweater	150, 151 & 155 with Ribber	32"-46"	26
11.	Ribby Sweater with Swiss Darning	150, 151, 155 Zippy 90	32"-46" 32"-42"	29 29
12.	Aran Crew Neck Cardigan	150, 151, 155 Zippy 90	32"-46" 32"-38"	32 32
13.	Black & White Intarsia Sweater	150, 151, 155 with Intarsia Zippy 90 with Intarsia	32"-46" 32"-42"	35 35
14.	Traditional Fair Isle Sweater	155	32"-42"	37

## **LADIES**

		<b>Knitmaster Machine</b>	<b>Size Range</b>	<b>Page No</b>
1.	Raglan V-neck Sweater	150, 151, 155 & Zippy 90	32"-46"	6
2.	Raglan V-neck Cardigan	150, 151, 155 & Zippy 90	32"-46"	6
3.	Raglan Crew Neck Sweater	150, 151, 155 & Zippy 90	32"-46"	6
4.	Raglan Crew Neck Cardigan	150, 151, 155 & Zippy 90	32"-46"	6
5.	Icelandic Sweater	155	32"-46"	10
6.	Icelandic Cardigan	155	32"-46"	10
7.	Shortie Fitted Sweater	150, 151, 155 & Zippy 90	32"-42"	13
8.	Aran Crew Neck Sweater	150, 151, 155 Zippy 90	32"-46" 32"-42"	16 16
9.	Floral Cropped Sweater	150, 151, 155 & Zippy 90	32"-46"	19
10.	English Rib Raglan Sweater	150, 151 & 155 with ribber	32"-46"	26
11.	Ribby Sweater with Swiss Darning	150, 151, 155 Zippy 90	32"-46" 32"-42"	29 29
12.	Aran Crew Neck Cardigan	150, 151, 155 Zippy 90	32"-46" 32"-38"	32 32
13.	Black & White Intarsia Sweater	150, 151, 155 with Intarsia Zippy 90 with Intarsia	32"-46" 32"-42"	35 35
14.	Traditional Fair Isle Sweater	155	32"-42"	37
15.	Peplum Cardigan	150, 151, 155 Zippy 90	32"-42" 32"-38"	39 39