

knitking

magazine

MAY/JUNE '76





HP 322

DK 325



DK 298

HP 323

KK 320



KK 319

KK 317

KK 316



DK 310

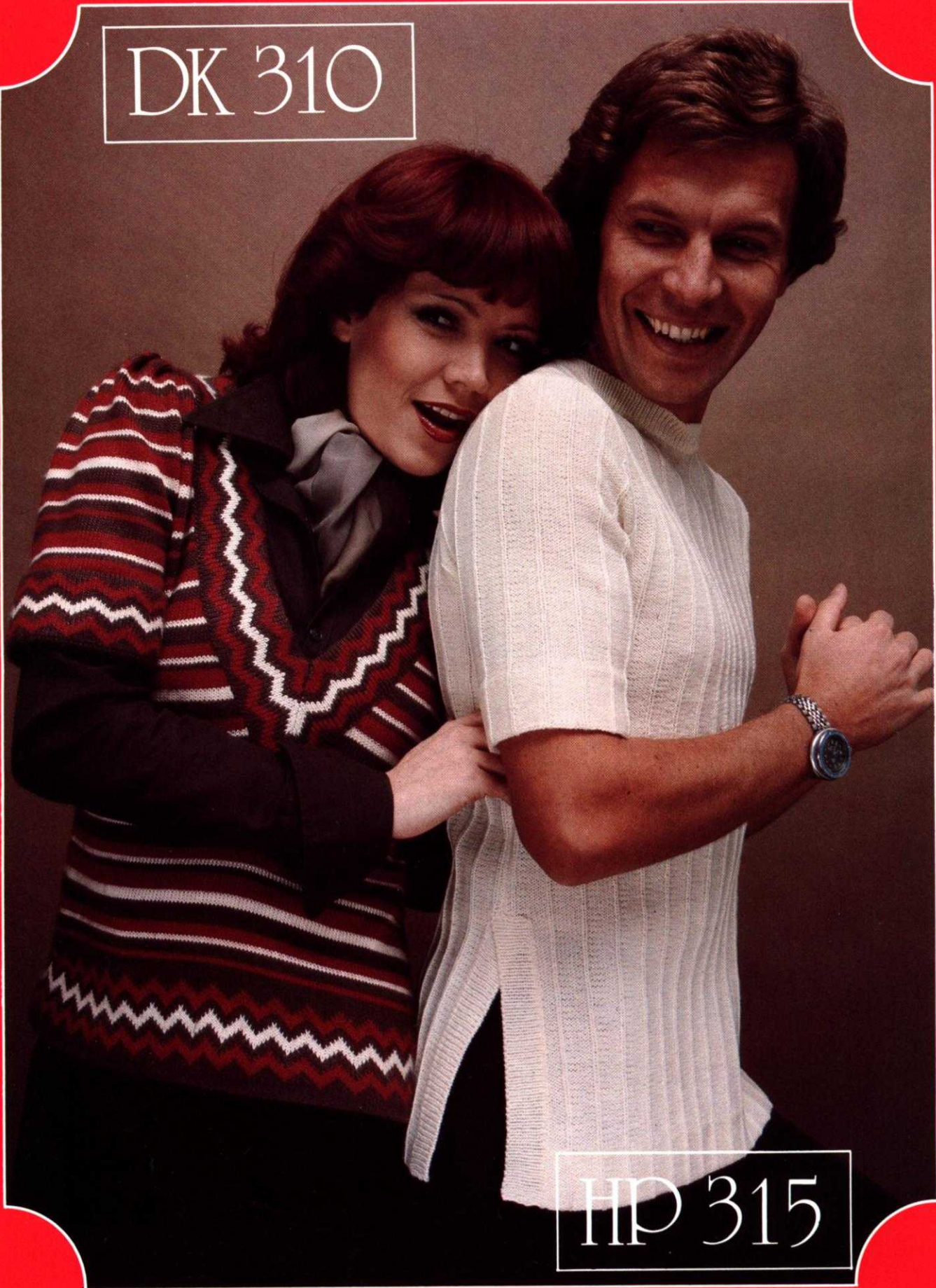

HP 315



DK 309

KK 318



DK 301



HP 314

DK 312



HP 324

DK 326

knitking

magazine

TABLE OF CONTENTS

PAGE NO.

| | | |
|--------|---------------------------------------|----|
| DK 297 | Woman's Tunic & Skirt | 14 |
| DK 298 | Woman's Pullover. | 15 |
| DK 299 | Woman's Vest. | 16 |
| DK 300 | Woman's Cardigan. | 17 |
| DK 301 | Woman's Pullover. | 18 |
| DK 302 | Woman's Jacket. | 20 |
| DK 303 | Woman's Shell | 21 |
| DK 304 | Woman's Dress | 21 |
| DK 305 | Woman's Blouse. | 22 |
| DK 306 | Woman's Jacket. | 23 |
| DK 307 | Woman's Jacket. | 24 |
| DK 308 | Woman's Coat. | 25 |
| DK 309 | Woman's Jacket. | 27 |
| DK 310 | Woman's Pullover. | 28 |
| DK 311 | Woman's 2-piece Dress | 29 |
| DK 312 | Woman's Pullover & Skirt. | 31 |
| DK 313 | Woman's Sleeveless Pullover | 32 |
| HP 314 | Man's Vest. | 33 |
| HP 315 | Man's Pullover. | 34 |
| KK 316 | Girl's Pleated Skirt. | 35 |
| KK 317 | Girl's Pullover | 36 |
| KK 318 | Teen Girl's Cardigan. | 36 |
| KK 319 | Boy's Pants & Pullover. | 37 |
| KK 320 | Girl's Raglan Pullover. | 38 |
| KK 321 | Child's Pullover. | 39 |
| HP 322 | Man's Jacket. | 40 |
| HP 323 | Man's Pullover. | 42 |
| HP 324 | Man's Jacket. | 43 |
| DK 325 | Woman's Jacket. | 45 |
| DK 326 | Woman's Pullover. | 46 |

editorial

EDITORIAL

MAY/JUNE 1976

Mrs. Peter Jaggi, Argyle Wisconsin writes:
"The JAN/FEB, MARCH/APRIL issues of your magazine are just super... Friends and relatives 'oh-d and ah'd at so many garments. I'll be quite busy all summer... Thank you."

Mrs. Carsten Johnsen, Benicia, California:
"I do look forward to receiving each new KNITKING MAGAZINE, for each one seems to be more colorful and interesting. The last one (JAN/FEB '76) is the best ever. The instructions are so easy to follow, the styles so pleasing. Thank you for the fine service I have received from KNITKING these past few years...."

Mabel E Schlatter, Estes Park, Colorado:
"The last two issues of KNITKING MAGAZINE are superb and I have orders for several of the garments shown. I couldn't do without it..."

Debbie McInnes, Bay of Islands, New Zealand:
"Everyone at KNITKING should be patting each other on the back. The MARCH/APRIL issue is fabulous! It's really nice to see so many 'in' things. I'm very glad your designers are giving us up to the minute garments..."

Mrs. Eugene Brown, Salt Lake City, Utah:
"I've just received the MARCH/APRIL issue. Now you're talking! It is such a relief to see imaginative more creative patterns for a change..."

















The foregoing excerpts are typical of the hundreds we have been receiving congratulating us on the 'NEW LOOK' KNITKING MAGAZINE... We thank you for taking the time to write and we especially thank those who tell us just what type and style of garments they like... We are now sending KNITKING MAGAZINE to 14 countries and we also print the GERMAN version that goes to many other countries...



It seems that everybody is happy with the way we are doing the job in LOS ANGELES... Now if we can only increase our subscriber list so that the magazine pays for itself, we too will be completely happy... So... don't share your magazine with a friend... tell her to pay for her own subscription and please encourage other knitting friends to subscribe so that we can all go on to a bigger and even better KNITKING MAGAZINE.







Watch out for our JULY/AUGUST Bicentennial issue.. We promise it will be outstanding.

Pattern Symbols

Knitting — Chart Symbols

- () Size Symbols (2nd Size)
 < > 3rd Size
- B** Beginners Pattern
T Tension
G Gauge
① Color Number
-  Cast on
 Stitch
 Row
 Hem
 Bind off
-  Stockinette stitch — worn on the Knit side.
 Stockinette stitch — worn on the Purl side.
 Knit 1, Purl 1 Ribbing
 Ribbing Pattern — worn on the Knit side.
 Ribbing Pattern — worn on the Purl side.
-  Closed Dart
 Open Dart
 Put on a stitch holder
 Reverse 1 section
 On every other needle
 Number of Rows between Shapings. Make increase (or decrease) FIRST, then knit 4 rows. For example: 3 x 1  means decrease (or increase) 1 st., knit 4 rows; decrease 1 st., knit 4 rows; decrease 1 st., knit 4 rows; decrease 1 st., knit 4 rows. All decreasing (or increasing) without row numbers as shown must be shaped on every 2nd row.





-  Increase
 Increase 2 sts. With a transfer tool, move the sts. over the left (or right) leaving 2 empty needles at the point of increase. At the increase point, move 1 st. to the left, (or right) so that there is an empty needles on each side of a stitch. On each side of the center stitch, pick up a stitch from the row below and hang it onto the empty needle.

-  3 stitches on 1 needle. The 1st and 3rd stitch in a group of 3 has been hung on the 2nd or center needle.
 Short Row increase or decrease; for instance on a flared skirt knitted sideways.
 Pattern Stitch
 Pattern Stitch — worn on the Knit side.
 Pattern Stitch — worn on the Purl side.
 Norwegian Design using the Pattern Reader. Only 1 row must be registered on the Pattern Reader, so when knitting two or more colors in 1 row, knit the first color with the LEVER of Pattern Reader UP (working), then push the LEVER DOWN (non-working) for the additional colors.
 REPEAT the above for each complete row.

















-  Repeat

- I = Front
 II = Back
 III = Sleeve
 IV = Skirt Front
 V = Skirt Back
 VI = Collar
 VII = Pocket
 VIII = Band
 IX = Belt
 X = Cuff
 XI = Pants Front
 XII = Pants Back

Finishing — Chart Symbols

-  Match numbers on section for assembling.
 Ease
 Fold Line
 Turn to the wrong side and hem.

Stitch Symbols

-  Knit Stitch
 Purl Stitch
 Needles in holding position
 Needles back into working position.
 Empty needle (leave in working position)
 Needle not used (in the out of work position).
 Two stitches on 1 needle, either transferred from the right side or the left side, then put into holding position.
 Needle holding 2 stitches. Stitch has been transferred from the RIGHT.
 Needle holding 2 stitches. Stitch has been transferred from the LEFT.
 Center of garment section
 Pattern Reader
 JAC 40
 Adjustable Needle Selector
 Pattern Wheel
 Weaver
 Needle Shifter

General Instructions

HOW TO READ THE CHARTS AND INSTRUCTIONS

There are 3 sizes given for each Pattern in KNITKING MAGAZINE. Above each Chart for the different sizes, you will see that the first and smaller sizes might be shown as 8/10, the second size as [12/14] and the third as [16/18]. Check the measurements at the bustline and hips on the Charts to be certain that you will knit the correct size, remembering these are ACTUAL measurements of the completed section and that there must be a bigger allowance at the bustline and hipline for a Jacket or a Coat than there would be for a fitted dress or a fitted blouse or pullover. The question in your mind should be "How do I want this garment to fit...?"

When you have chosen the size you need, you can follow the Charts as shown. You will notice that where the shapings are the same FOR ALL SIZES, only 1 set of shapings will be shown on the first Chart and if you are knitting the 2nd or 3rd size, you simply follow the shapings as given for the first size. If the shapings are different, this will be shown on the Charts and you should follow them as given.

On the Charts, increases and decreases will be shown as follows

5x1
6 The number in the box means number of ROWS between the shapings, while the 5x1 above the box means - 1 st. 5x... so you will increase or decrease 1 st. every 6th row 5x.

ARMHOLE SHAPINGS - NECK SHAPINGS - SHOULDER SHAPINGS - are made on every 2nd row UNLESS there is a number in a box along side or below the shapings. The rule is... where there is no box with a number, the shaping is made on every 2nd row.

THE PRINTED INSTRUCTIONS

You can follow the printed instructions or use them in combination with the Charts. Where there is any question in the printed instructions, you have the Charts to show you how the section will look.

The 3 sizes, with the different amounts of cast on stitches and the different shapings will look like this...

Cast on 124 (136) [148] sts. You will

Cast on 124 sts. for the first size.

Cast on 136 sts. for the 2nd size.

Cast on 148 sts. for the 3rd size.

The important thing to remember is that you MUST READ AHEAD so that you KNOW what to do for the size you are knitting. Sometimes where the number of stitches are the same but the number of times different, you will find shapings like this...

3 sts. 1x (2x) [3x], 2 sts. 1x (2x) [3x], 1 st. 3x (4x) [5x]. As you see, you MUST read ahead in order to follow the instructions as given for YOUR SIZE. The rows will be different for the different sizes in some cases... Shoulder and Neck shapings usually are worked at the SAME TIME for the back section - so watch for the words AT THE SAME TIME.

HOLDING STITCHES ON THE LEFT SIDE WHILE SHAPING THE RIGHT SIDE

When knitting a section of garment in stockinette stitch, it is easy to hold the stitches on the left side while knitting the right half, but when knitting a Pattern Stitch such as a Norwegian Design, a Holding Position Design, Weaving, etc., you should use the following method. For the NECK SHAPING, we tell you to bind off the center sts., put the needles on the left into holding position and complete the right half first... so with a strand of contrast yarn, knit ALL of the left side stitches manually by hand, pulling each stitch back against the needle bed to the OUT OF WORK position. When the right side is completed, carefully pull the stitches held on contrast, forward into working position and as you do so, undo the contrast yarn, line up the needles (KNITKING machine owners, put the stitches under the sinkers) and complete the left half.

If you own a Japanese machine, you may find that when knitting the right half with the left side held in this way, the sinker plate will mark the left side while you are knitting the right half. To prevent this marking, you can tape a piece of paper over the knitting, underneath the sinkers, or if you own a Reversing Bar, you can hang this onto the Sinkers while you are knitting the right half. When hanging the Reversing Bar, be sure the eyes of the bar go BETWEEN the Sinker Posts on the upper part of the bar so that the tips of the bar only - show above the needle bed.

FULL FASHION DECREASING OR INCREASING

For Stockinette stitch, always use the Full Fashion method for increasing or decreasing.

TO DECREASE: Hang the 3rd stitch onto the 2nd stitch then move the stitches in to fill the empty needle.

TO INCREASE: Move the 2 end stitches 1 needle outward, then pick up the 3rd stitch from the row below and hang it onto the empty needle.

NORWEGIAN DESIGNS:

In the instructions, each row of the Norwegian Design is counted as 1 row but several movements of the Cam Box (or Slide) are needed to complete 1 row.

NORWEGIAN DESIGN WHEN USING THE PATTERN READER

When you use the Pattern Reader and knit a Norwegian Design using several colors, it is necessary to move the Trip Control Lever so that only 1 row registers.

FINISHING: Block all sections. For PULLOVERS, JACKETS, and DRESSES: Join front to back at sides and shoulders. Sew sleeves together and set in. Hem lower edge and sleeve edges if needed. For a double neckband or armhole band, sew 1 edge to the inside and 1 to the outside of neck or armhole. For a single ribbed band, sew 1 edge to the outside of neck or armhole edge. For a cardigan or jacket with buttonholes, finish buttonholes and sew on buttons.

PANTS: Join front to back at sides. Sew inside leg seams, then join center front and back. Make hem at waistline and insert elastic. Hem lower edge of pants legs.

THE SAMPLE SWATCH

Before you begin to knit any garment, you will need to knit a sample piece using the yarn you have chosen for your garment, so that you can check the stitch and row gauge which must measure the correct number of stitches and rows in 5 cm (2 inches).

For each Pattern in KNITKING MAGAZINE, we give you 3 tension numbers to work from and if you use the specified yarn for the garment, you should be able to get the correct stitch and row gauge using one of these numbers. Here is a very easy way to make your sample swatch and count the stitches and rows without actually counting, by using our KNITKING Converta Tape.

Supposing the Tension Numbers for the Stitch and Row Gauge are given as 5 to 7. Set the Tension Dial to the first number which is 5. With contrast waste yarn, and using the quick cast on method, cast on 60 stitches and knit 10 rows. Change to garment yarn and turn the Row Counter to 0. Knit 30 rows. Counting from each end, knit the 10th stitch on each side by hand with a small piece of contrast yarn. Leave the needles in working position and knit 30 rows (Row 60), then knit 4 rows with contrast waste yarn. Turn the Row Counter to 0 and the Tension Dial to 6 and with garment yarn, knit 30 rows. Mark the 10th stitch on each side as you did before, knit 30 rows, then 4 rows with contrast waste yarn. Turn the Row Counter to 0 and with Tension 7, repeat the above once more, ending with 10 rows of contrast waste yarn. Remove the work from the machine by passing the Slide across the needles without yarn (sometimes called 'dropping').

Pull and stretch the sample piece both lengthwise and diagonally from corner to corner, then lengthwise again. Do not count the stitches and rows immediately, but allow the sample to rest for several hours or even over night. This will allow the stitches and rows to return to their basic form.

When your sample has rested and you are ready to count the stitches and rows, the KNITKING CONVERTA TAPE will do the counting for you without any counting on your part. Use the Tape as follows:

To measure the stitches, pull out the Tape to measure BETWEEN the 40 stitches in the center that you marked by hand knitting with contrast waste yarn - Push the red marker on the Tape so that it points to 40 stitches on the Tape. Your stitch gauge to 5 cm (2 inches) will shown in the red window on the tape. To find the number of rows in 5 cm (2 inches), place the tape to measure over 60 rows, push the red marker to 60 on the tape and your row gauge for 5 cm (2 inches) will show in the red window... Easy...? If you do not get the correct stitch and row gauge in the first part of your sample, then try the other two.

If you do not own a KNITKING CONVERTA TAPE, you must mark a 5 cm (2 inch) square in the center of the knitting, then count the number of stitches and rows within the square.

DK 297

WOMAN'S TUNIC & SKIRT

SIZE: 8/10 (12/14) [16/18]
 YARN: Allegro
 GRAMS:
 color 1 500 550 600
 color 2 250 300 300
 TENSION: 6 to 8
 GAUGE: 15 sts. 21 rows = 5 cm (2")



The Tunic is a Norwegian Design using 2 colors. Skirt and bands are Stockinette stitch.

FINISHING: See General Instructions.

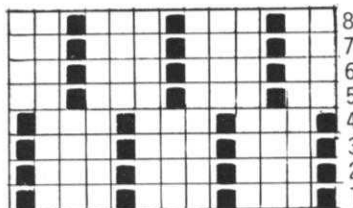

■ color 2
 □ color 1

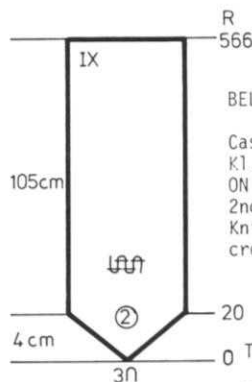

BELT: IX

Cast on 3 sts. with color 2 and work K1, P1 Ribbing.
 ON EACH SIDE, increase 2 sts. every 2nd row 10x.
 Knit to Row 566, then bind off the crochet method for Ribbing.

TUNIC BACK: II

Cast on 114 (126) [138] sts. with color 1 and work the Norwegian Design. Knit to Row 12, then hang the hem.
 ON EACH SIDE, decrease 1 st. every 30th row 6x, every 28th row 3x.
 (every 22nd row 8x, every 20th row 4x).
 [every 18th row 6x, every 16th row 9x].
 Knit to Row 276.

Bind off the center 30 sts., put the needles on the left into holding position and complete the right half first.

*SHAPE SHOULDER AND NECK AT THE SAME TIME.

FOR SHOULDER, bind off 3 sts. 2x, 4 sts. 3x. (4 sts. 4x, 5 sts. 1x). [4 sts. 1x, 5 sts. 4x].

FOR NECK, on all sizes, bind off 5 sts. 3x.

Bring the needles on the left into working position, knit 1 row in Pattern to the left side, turn the Row Counter back to 276 and complete the left half. Follow the instructions from *.

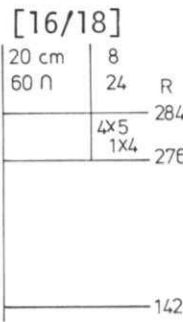
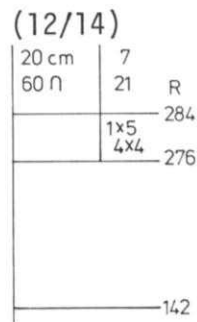
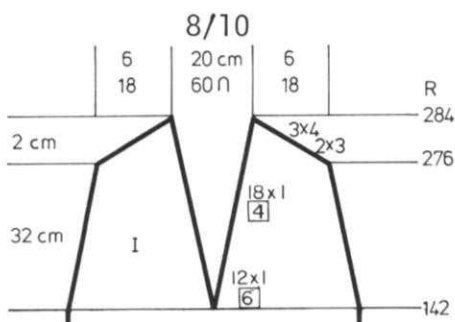
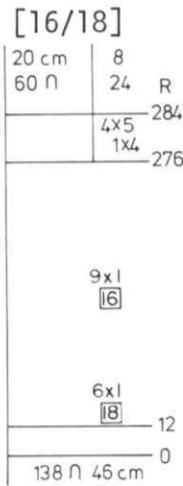
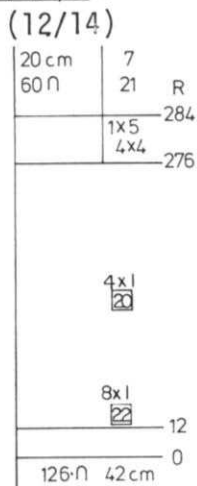
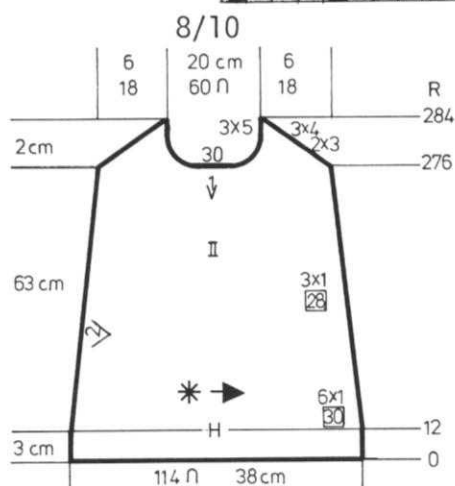

FRONT: I

Work the front the same as the back to Row 142.

Divide in the center, put the needles on the left into holding position and complete the right half first.

*Continue the decreases on side edge the same as the back and ON NECK SIDE, for all sizes, bind off 1 st. every 6th row 12x, every 4th row 18x, and SHAPE SHOULDER same as the back after Row 276.

Bring the needles on the left into working position, knit 1 row in Pattern to the left side, turn the Row Counter back to 142 and complete the left half. Follow the instructions from *.

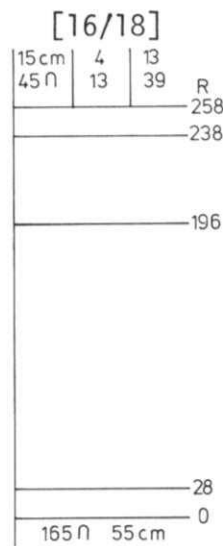
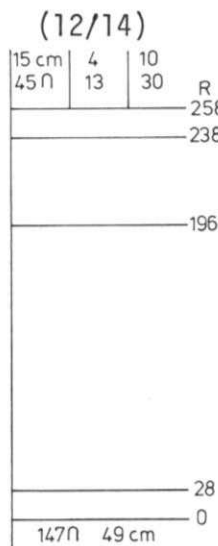
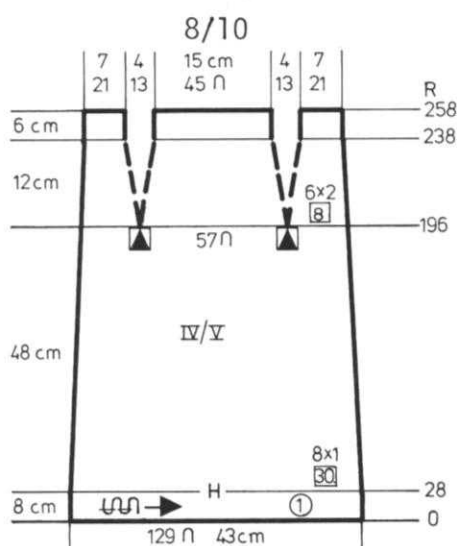

SKIRT FRONT & BACK: IV/V

Cast on 129 (147) [165] sts. with color 1 and work Stockinette stitch.

Knit to Row 28, then hang the hem. ON EACH SIDE, decrease 1 st. every 30th row 8x.

After Row 196, ON EACH SIDE, decrease 2 sts. FOR EACH DART.

The first DART decrease is made ON EACH SIDE of the center 57 sts. with the following dart decreases directly above.

Decrease 2 sts. for EACH DART every 8th row 5x more.

Knit to Row 258, then bind off. Make the 2nd section the same.

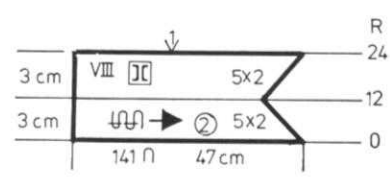

NECKBAND: VIII Make 1, reverse 1.

Cast on 141 sts. with color 2 and work Stockinette stitch.
ON THE RIGHT (left for 2nd section) decrease 2 sts. every 2nd row 5x, then increase 2 sts. every 2nd row 5x. After Row 24, bind off.

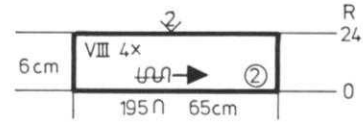

SIDE BANDS: VIII Make 4.
Cast on 195 sts. with color 2 and work 24 rows Stockinette stitch then bind off.

DK 298

WOMAN'S PULLOVER

SIZES: 7/8 (10/12) [16]
YARN: Allegro
GRAMS:
color 1 200 250 300
color 2 50 50 50
color 3 50 50 50
TENSION: 6 to 8
GAUGE: 16 sts. 20 rows = 5 cm (2")

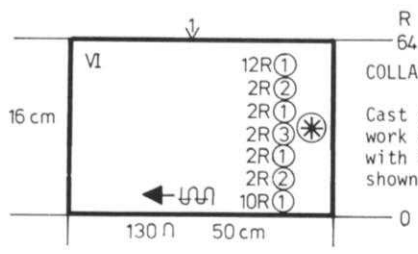

COLLAR: VI

Cast on 130 sts. with color 1 and work 64 rows Stockinette stitch with REPEATED color stripes as shown on the Chart, then bind off.

Stockinette stitch with color stripes as shown on the Chart.
Worn on the Purl side.
Bands are K1, P1 Ribbing.

FINISHING: See General Instructions.
Ease the extra rows at bustline of front section.

BACK: II

Cast on 109 (119) [135] sts. with color 1 and work 36 rows K1, P1 Ribbing.
Change to Stockinette stitch with color stripes as shown on the Chart. Knit to Row 152.

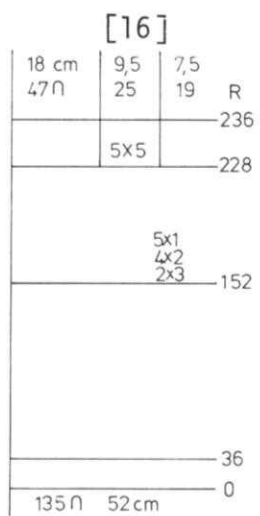
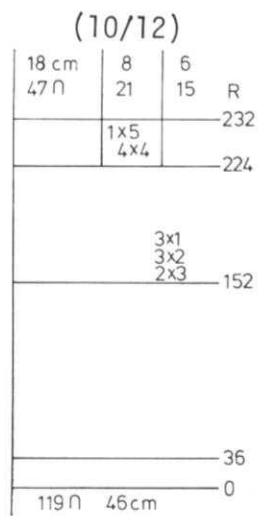
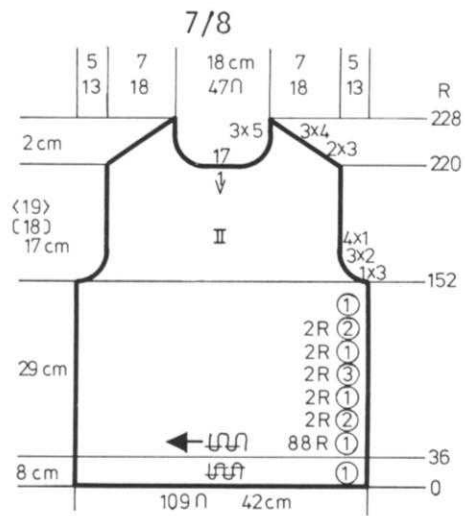

SHAPE ARMHOLE: ON EACH SIDE, bind off
3 sts. 1x, 2 sts. 3x, 1 st. 4x.
(3 sts. 2x, 2 sts. 3x, 1 st. 3x).
[3 sts. 2x, 2 sts. 4x, 1 st. 5x].
Knit to Row 220 (224) [228].
Bind off the center 17 sts., put the needles on the left into holding position and complete the right half first.
*SHAPE SHOULDER AND NECK AT THE SAME TIME.
FOR SHOULDER, bind off
3 sts. 2x, 4 sts. 3x.
(4 sts. 4x, 5 sts. 1x)
[5 sts. 5x].
FOR NECK, on all sizes, bind off 5 sts. 3x.
Move the Cam Box to the left side, turn the Row Counter back to 220 (224) [228] and complete the left side. Follow the instructions from *.

FRONT: I

Work the front the same as the back to Row 152, then knit to Row 164.
SHAPE ARMHOLE same as the back then knit to Row 204 (208) [212].
Bind off the center 13 sts., put the needles on the left into holding position and complete the right half first.
*ON NECK SIDE for all sizes, bind off 3 sts. 2x, 2 sts. 3x, 1 st. 5x, and SHAPE SHOULDER same as the back after Row 232 (236) [240].
Move the Cam Box to the left side, turn the Row Counter back to 204 (208) [212] and complete the left half. Follow the instructions from *

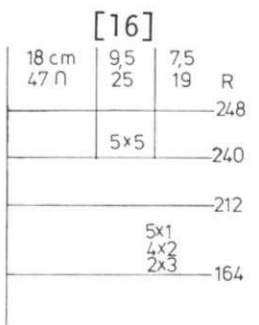
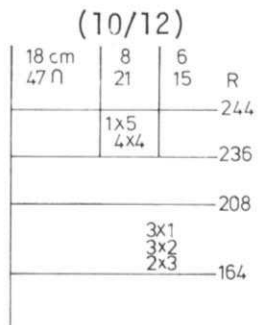
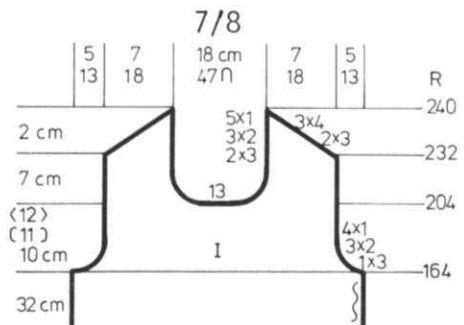

Continued

DK 298

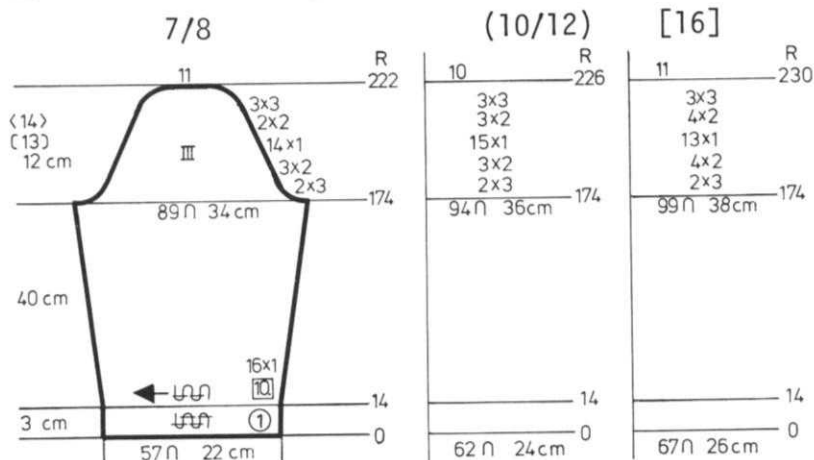

SLEEVE: III

Cast on 57 (62) [67] sts. with color 1 and work 14 rows K1, P1 Ribbing. Change to Stockinette stitch and ON EACH SIDE, increase 1 st. every 10th row 16x. Knit to Row 174. SHAPE CAP: ON EACH SIDE, bind off 3 sts. 2x, 2 sts. 3x, 1 st. 14x, 2 sts. 2x, 3 sts. 3x. (3 sts. 2x, 2 sts. 3x, 1 st. 15x, 2 sts. 3x, 3 sts. 3x). [3 sts. 2x, 2 sts. 4x, 1 st. 13x, 2 sts. 4x, 3 sts. 3x]. After Row 222 (226) [230], bind off the remaining 11 (10) [11] sts.

DK 299

WOMAN'S VEST

SIZES: 8/10 (12/14) [16/18]
 YARN: Crocus Crepe
 GRAMS: 250 300 350
 TENSION: 6 to 8
 GAUGE: 15 sts. 20 rows = 5 cm (2")

A Holding Position Design that follows the Line Drawing. KNITTING machine owners use Wheel No. 2 and push in the LEFT Retractor Button and leave it there. The purl side is the right side. Bands are K1, P1 Ribbing.

FINISHING: See General Instructions.

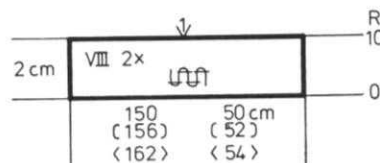

ARMBANDS: VIII Make 2.

Cast on 150 (156) [162] sts. and work 10 rows K1, P1 Ribbing, then bind off the crochet method for Ribbing.



FRONT: I Make 1, reverse 1.

DO NOT MAKE BUTTONHOLES IN THIS SECTION.

Cast on 72 (78) [84] sts. and work 14 rows K1, P1 Ribbing. Leave 9 sts. on the LEFT (right for 2nd section) in K1, P1 Ribbing and transfer the remaining rib stitches to the main machine. Continue in Holding Position Design with the 9 sts. in K1, P1 Ribbing. ON SIDE EDGE, decrease 1 st. every 6th row 6x, every 4th row 2x. Knit to Row 76. ON SIDE EDGE, increase 1 st. every 10th row 2x, every 8th row 6x AND AT THE SAME TIME, after Row 120, remove the 9 rib sts. onto contrast waste yarn. Remove the Ribber from the machine and continue in Pattern. ON NECK SIDE, decrease 1 st. every 4th row 17x (15x) [13x], every 6th row 8x (10x) [12x] and SHAPE ARMHOLE same as the back after Row 144 and SHAPE SHOULDER same as the back after Row 228 (232) [236]. Return the stitches held on waste yarn to the main machine and Ribber. Turn the Row Counter back to 120 and work K1, P1 Ribbing to Row 272 (276) [280]. Bind off the crochet method for Ribbing. Make the 2nd section with reverse shaping and work BUTTONHOLES over needles 3 to 7 counting from the RIGHT edge, after the rows shown on the Chart.

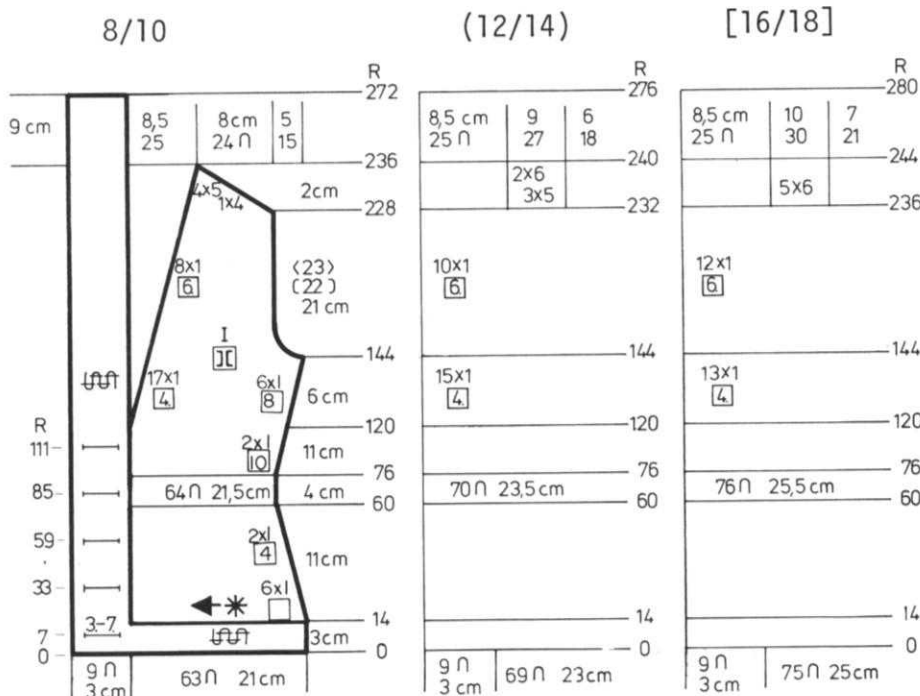

BACK: II

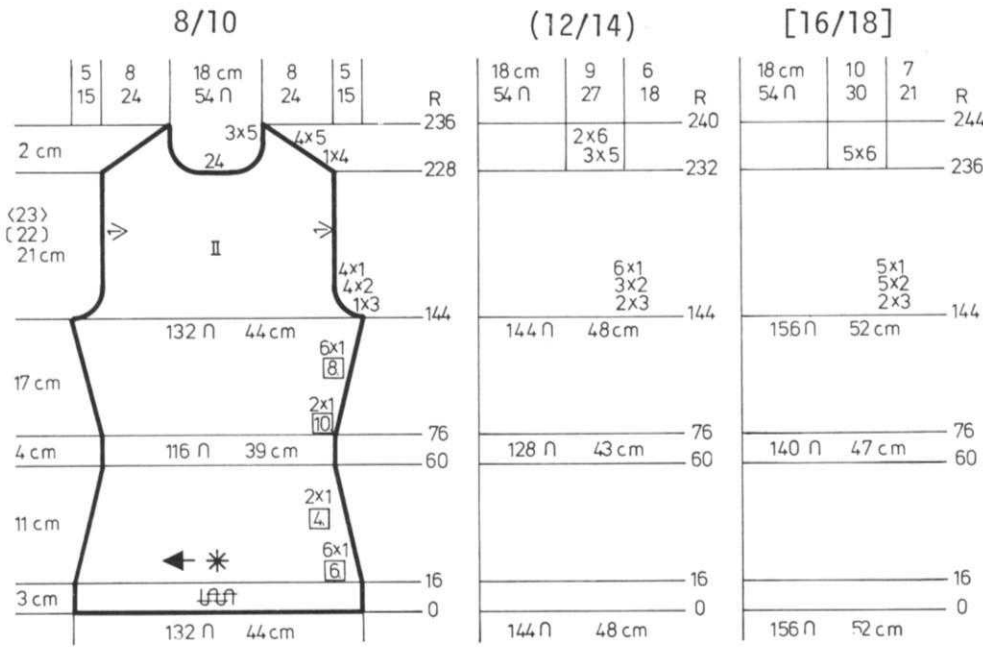

Cast on 132 [144] [156] sts. and work 16 rows K1, P1 Ribbing. Change to the Holding Position Design. ON EACH SIDE, decrease 1 st. every 6th row 6x, every 4th row 2x. Knit to Row 76. ON EACH SIDE, increase 1 st. every 10th row 2x, every 8th row 6x. Knit to Row 144. SHAPE ARMHOLE: ON EACH SIDE, bind off 3 sts. 1x, 2 sts. 4x, 1 st. 4x. (3 sts. 2x, 2 sts. 3x, 1 st. 6x). [3 sts. 2x, 2 sts. 5x, 1 st. 5x]. Knit to Row 228 (232) [236]. Bind off *the center 24 sts., put the needles on the left into holding position and complete the right half first. *SHAPE SHOULDER AND NECK AT THE SAME TIME. FOR SHOULDER, bind off 4 sts. 1x, 5 sts. 4x. (5 sts. 3x, 6 sts. 2x). [6 sts. 5x]. FOR NECK, on all sizes bind off 5 sts. 3x. Move the Cam Box to the left side, turn the Row Counter back to 228 (232) [236] and complete the left half. Follow the instructions from *.

DK 300

WOMAN'S CARDIGAN

SIZES: 8 (10/12) [14/16]
 YARN: Allegro
 GRAMS: color 1 300 350 400
 color 2 50 100 100
 TENSION: 8 to 10
 GAUGE: 12 sts. 16 rows = 5 cm (2")

Stockinette stitch with REPEATED color stripes as shown on the Chart. Worn on the purl side. Bands are K1, P1 Ribbing.

FINISHING: See General Instructions.

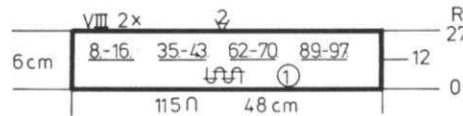

FRONT BANDS: VIII Make 2 but omit buttonholes in 2nd section.

Cast on 115 sts. and work K1, P1 Ribbing. After Row 12, make BUTTONHOLES over needles 8 to 16, 35 to 43, 62 to 70, 89 to 97 counting from the LEFT edge. After Row 27, bind off the crochet method for Ribbing.



BACK: II

Cast on 103 (111) [123] sts. with color 1 and work 26 rows K1, P1 Ribbing. Change to Stockinette stitch. Knit to Row 56 then work the REPEATED color stripes as shown on the Chart to Row 110. Continue with color 1. SHAPE ARMHOLE: ON EACH SIDE, bind off 3 sts. 1x, 2 sts. 3x, 1 st. 3x. (3 sts. 1x, 2 sts. 3x, 1 st. 5x). [3 sts. 2x, 2 sts. 3x, 1 st. 5x]. Knit to Row 168 (174) [182]. Bind off the center 13 sts., put the needles on the left into holding position and complete the right half first. *SHAPE SHOULDER AND NECK AT THE SAME TIME. FOR SHOULDER bind off 2 sts. 1x, 3 sts. 5x. (3 sts. 5x, 4 sts. 1x). [3 sts. 2x, 4 sts. 4x]. FOR NECK, on all sizes, bind off 4 sts. 4x. Move the Cam Box to the left side, turn the Row Counter back to 168 (174) [182] and complete the left half. Follow the instructions from *.

COLLAR: VI

Cast on 129 sts. with color 1 and work K1, P1 Ribbing. ON EACH SIDE, on every 6th row, decrease 2 sts. 7x. After Row 42, bind off the remaining sts. the crochet method for Ribbing.

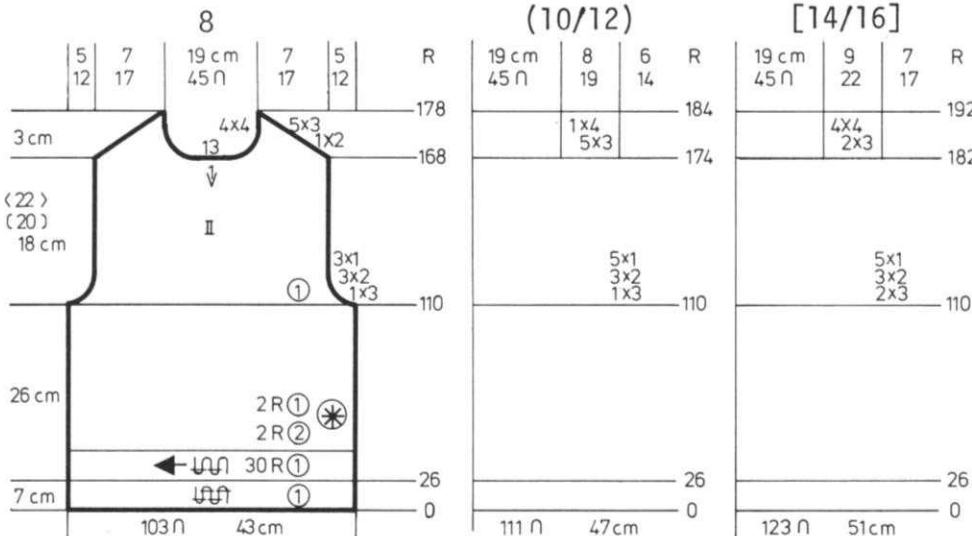
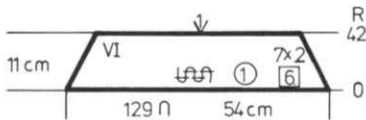

Continued



DK 300

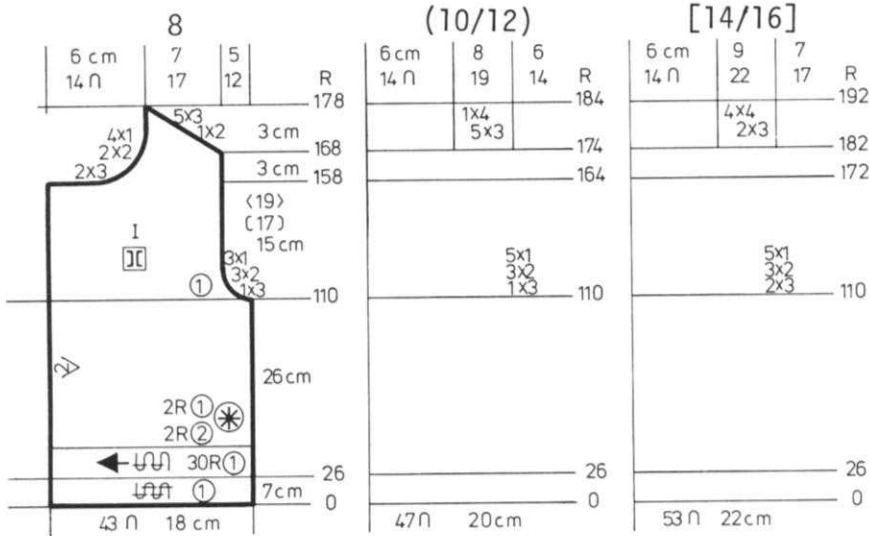

FRONT: I Make 1, reverse 1.

Cast on 43 (47) [53] sts. with color 1 and work 26 rows K1, P1 Ribbing. Change to Stockinette stitch and knit 30 rows color 1 then work the REPEATED color stripes as shown on the Chart to Row 110. Continue with color 1. SHAPE ARMHOLE same as the back then knit to Row 157 (163) [171]. ON NECK SIDE, for all sizes, bind off 3 sts. 2x, 2 sts. 2x, 1 st. 4x and AT THE SAME TIME, SHAPE SHOULDER same as the back after Row 168 (174) [182].

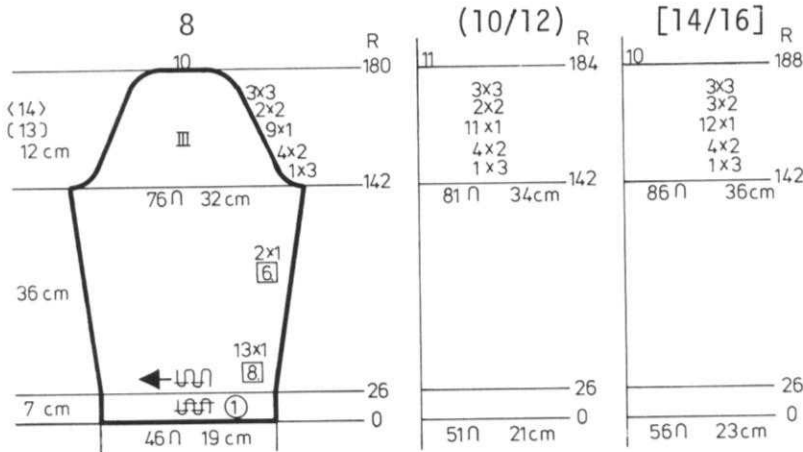

SLEEVE: III

Cast on 46 (51) [56] sts. with color 1 and work 26 rows K1, P1 Ribbing. Change to Stockinette stitch. ON EACH SIDE, increase 1 st. every 8th row 13x, every 6th row 2x. Knit to Row 142. SHAPE CAP: ON EACH SIDE, bind off 3 sts. 1x, 2 sts. 4x, 1 st. 9x, 2 sts. 2x, 3 sts. 3x. (3 sts. 1x, 2 sts. 4x, 1 st. 11x, 2 sts. 2x, 3 sts. 3x). [3 sts. 1x, 2 sts. 4x, 1 st. 12x, 2 sts. 3x, 3 sts. 3x]. After Row 180 (184) [188], bind off the remaining 10 (11) [10] sts.

DK 301

WOMAN'S PULLOVER

SIZES: 10/12 (14/16) [18/20]
 YARN: Vienna
 GRAMS: 450 (500) [550]
 TENSION: 4 to 6
 GAUGE: 15 sts. 24 rows = 5 cm (2")

A Holding Position Design that follows the Line Drawing. KNITTING machine owners, use Wheel No. 1 and push in the LEFT Retractor Button and leave it there. Worn on the Purl side. Bands are Stockinette stitch.

FINISHING: See General Instructions. Ease in extra fullness at bustline of front section.

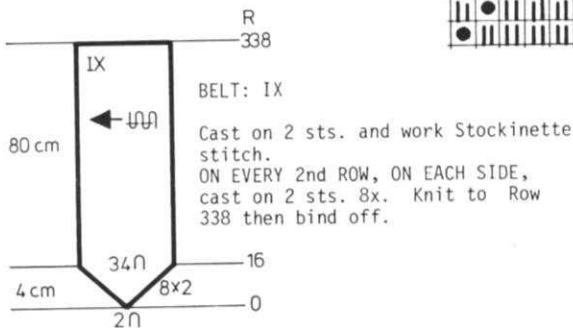

BELT: IX

Cast on 2 sts. and work Stockinette stitch. ON EVERY 2nd ROW, ON EACH SIDE, cast on 2 sts. 8x. Knit to Row 338 then bind off.

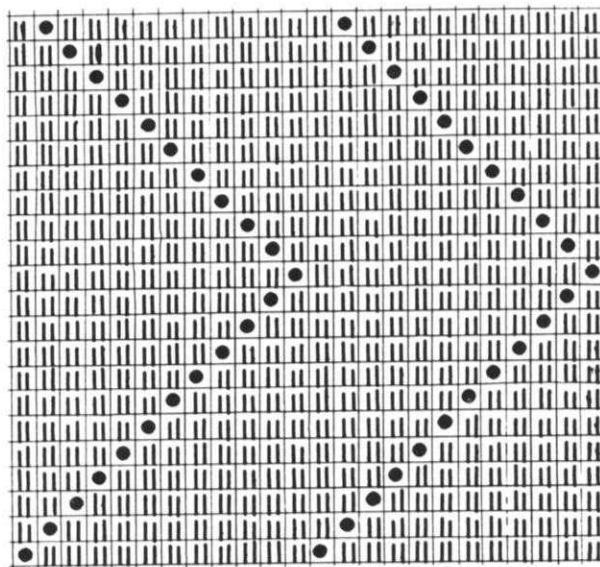

FRONT BANDS: VIII Make 2 and omit buttonholes in 2nd section.

Cast on 24 sts. and work Stockinette stitch. Make BUTTONHOLES over needles 3 to 8 and 17 to 22 counting from the LEFT edge after the rows shown on the Chart. After Row 88 (96) [104], bind off.

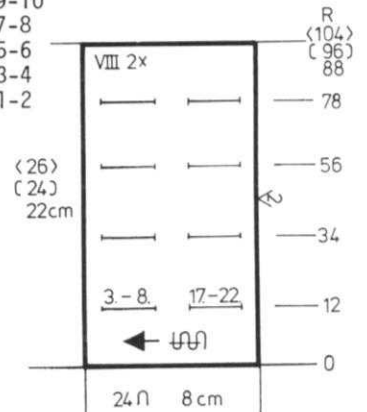

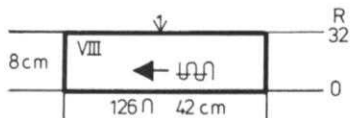

NECKBAND: VIII

Cast on 126 sts. and work 32 rows Stockinette stitch then bind off.

BACK: II

Cast on 138 (150) [164] sts. and work the Holding Position Design. After Row 28, ON EACH SIDE, decrease 1 st. every 8th row 7x. After Row 92, ON EACH SIDE, increase 1 st. every 14th row 7x.

Knit to Row 188. SHAPE ARMHOLE: ON EACH SIDE, bind off

3 sts. 2x, 2 sts. 2x, 1 st. 5x. (3 sts. 2x, 2 sts. 3x, 1 st. 6x). [3 sts. 3x, 2 sts. 4x, 1 st. 5x]. Knit to Row 280 (288) [298].

Bind off the center 18 sts., put the needles on the left into holding position and complete the right half first.

*SHAPE SHOULDER AND NECK AT THE SAME TIME.

FOR SHOULDER, bind off

3 sts. 2x, 4 sts. 6x.

(4 sts. 7x, 5 sts. 1x).

[4 sts. 4x, 5 sts. 4x].

FOR NECK, on all sizes,

bind off 3 sts. 3x, 2 sts. 3x.

Bring the needles on the left into working position, knit 1 row in

Pattern to the left side, turn the

Row Counter back to 280 (288) [298]

and complete the left half. Follow

the instructions from *.

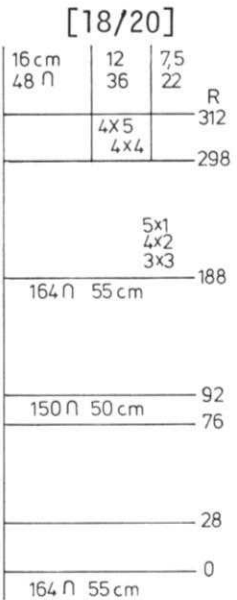
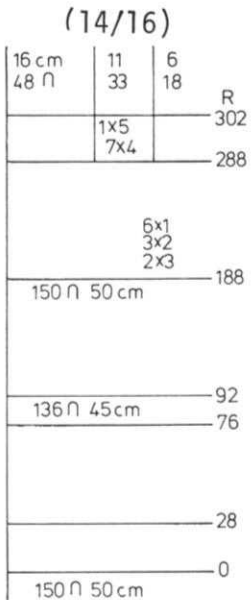
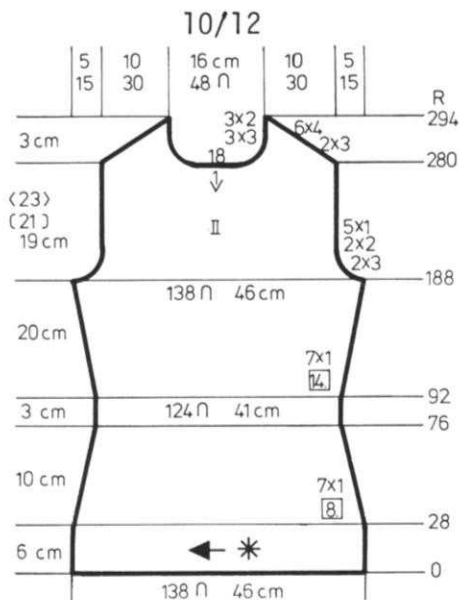

FRONT: I

Work the front the same as the back to Row 174.

Divide for the front opening: Put 80 needles on the left into holding position and complete the right side first.

Make the last side increase after Row 176 then knit to Row 202.

SHAPE ARMHOLE same as the back then knit to Row 279 (287) [297].

ON NECK SIDE for all sizes, bind off 3 sts. 1x, 2 sts. 2x, 1 st. 5x and

AT THE SAME TIME, SHAPE SHOULDER same as the back after Row 294 (302) [312].

Bring the needles on the left into working position, knit 1 row in

Pattern to the left side, turn the Row Counter back to 174.

Make the last side increase after Row 176, then knit to Row 202.

SHAPE ARMHOLE same as the back, then knit to Row 279 (287) [297].

ON NECK SIDE for all sizes, bind off 3 sts. 3x, 2 sts. 5x, 1 st. 5x and

AT THE SAME TIME, SHAPE SHOULDER same as the back after Row 294 (302) [312].

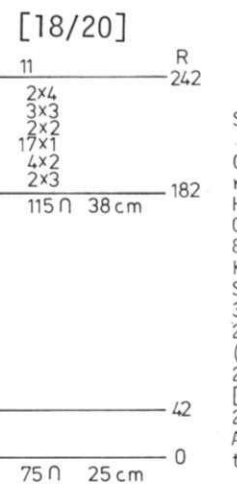
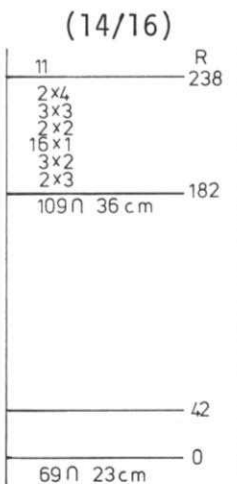
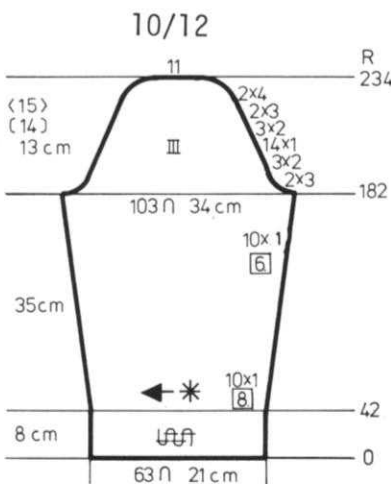
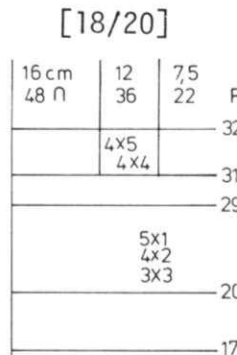
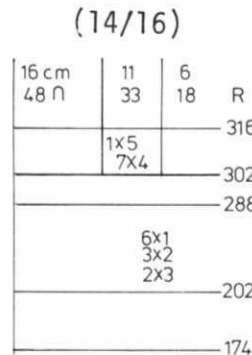
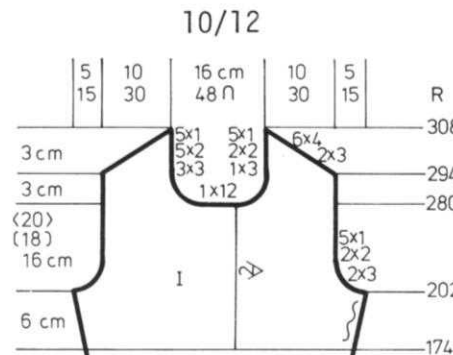

SLEEVE: III

Cast on 63 (69) [75] sts. and work 42 rows K1, P1 Ribbing. Change to the Holding Position Design.

ON EACH SIDE, increase 1 st. every 8th row 10x, every 6th row 10x. Knit to Row 182.

SHAPE CAP: ON EACH SIDE, bind off

3 sts. 2x, 2 sts. 3x, 1 st. 14x,

2 sts. 3x, 3 sts. 2x, 4 sts. 2x.

(3 sts. 2x, 2 sts. 3x, 1 st. 16x,

2 sts. 2x, 3 sts. 3x, 4 sts. 2x).

[3 sts. 2x, 2 sts. 4x, 1 st. 17x,

2 sts. 2x, 3 sts. 3x, 4 sts. 2x].

After Row 234 (238) [242], bind off

the remaining 11 sts.

DK 302

WOMAN'S JACKET

SIZES: 6/7 (8/10) [12/14]
 YARN: Amore
 GRAMS: 250 300 350
 TENSION: 7 to 9
 GAUGE: 13 sts. 24 rows = 5 cm (2")



Stockinette stitch with an Eyelet
 Design on the Pocket only. See DK 303
 Bands are K1, P1 Ribbing.

FINISHING: See General Instructions.

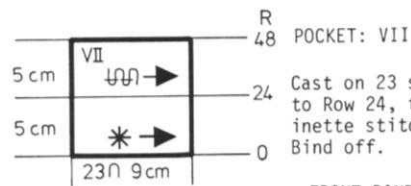

Cast on 23 sts. and work in Pattern to Row 24, then change to Stockinette stitch and knit to Row 48. Bind off.

FRONT BANDS: VII Make 2 and omit buttonholes in 2nd section.

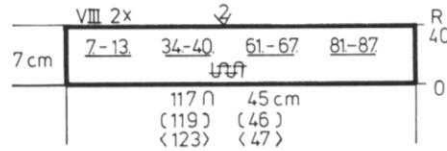

Cast on 117 (119) [123] sts. and work K1, P1 Ribbing. After Row 20, make BUTTONHOLES over the needles as shown on the Chart. After Row 40, bind off the crochet method for Ribbing.

BACK: II

Cast on 104 (114) [124] sts. and work 18 rows K1, P1 Ribbing. Change to Stockinette stitch. Knit to Row 148. SHAPE ARMHOLE: ON EACH SIDE, bind off 3 sts. 1x, 2 sts. 3x, 1 st. 4x. (3 sts. 2x, 2 sts. 3x, 1 st. 4x). [3 sts. 2x, 2 sts. 4x, 1 st. 4x]. Knit to Row 234 (240) [244]. Bind off the center 12 sts., put the needles on the left into holding position and complete the right half first. *SHAPE SHOULDER AND NECK AT THE SAME TIME. FOR SHOULDER, bind off 2 sts. 3x, 3 sts. 5x. (2 sts. 1x, 3 sts. 7x). [3 sts. 6x, 4 sts. 2x]. FOR NECK, on all sizes, bind off 3 sts. 4x. Move the Cam Box to the left side, turn the Row Counter back to 234 (240) [244] and complete the left half. Follow the instructions from *.

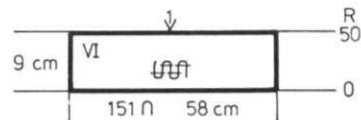
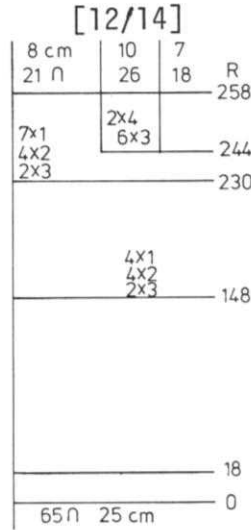
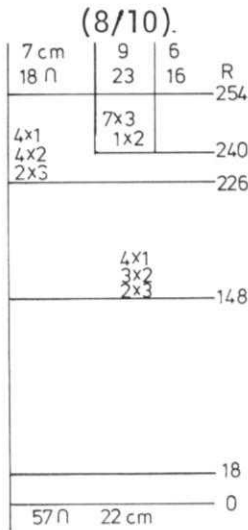
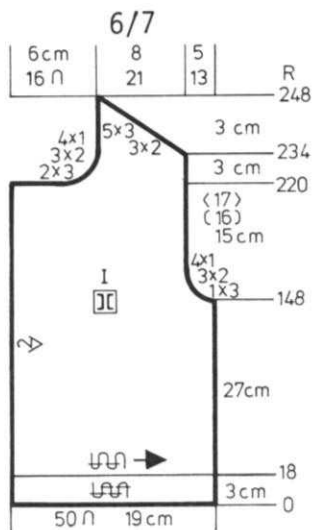
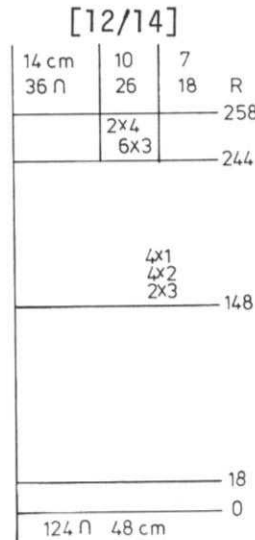
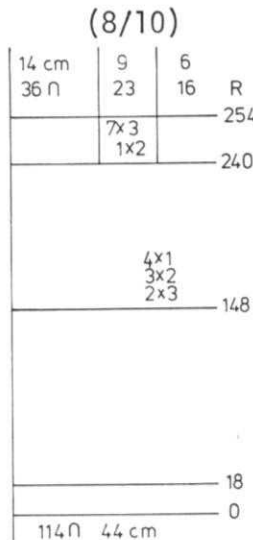
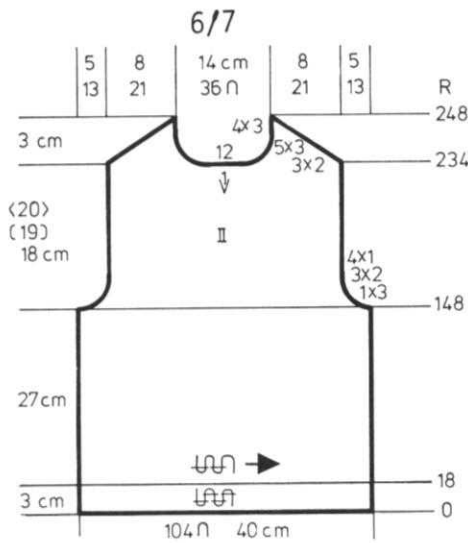

COLLAR: VI
 Cast on 151 sts. and work 50 rows K1, P1 Ribbing then bind off the crochet method for Ribbing.

FRONT: I Make 1, reverse 1.

Cast on 50 (57) [65] sts. and work 18 rows K1, P1 Ribbing. Change to Stockinette stitch and knit to Row 148. ON SIDE EDGE, SHAPE ARMHOLE same as the back then knit to Row 219 (225) [229]. SHAPE NECK: Bind off 3 sts. 2x, 2 sts. 3x (4x) [4x], 1 st. 4x (4x) [7x] and AT THE SAME TIME SHAPE SHOULDER after Row 234 (240) [244].

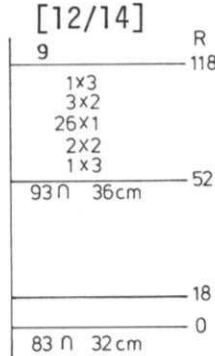
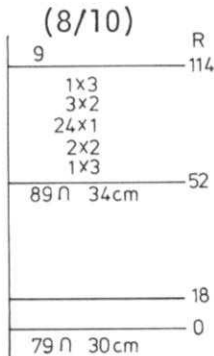
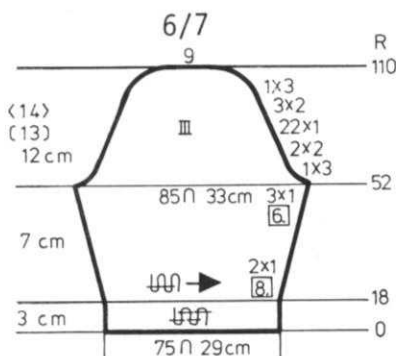

SLEEVE: III

Cast on 75 (79) [83] sts. and work 18 rows K1, P1 Ribbing. Change to Stockinette stitch and ON EACH SIDE, increase 1 st. every 8th row 2x, every 6th row 3x. Knit to Row 52. SHAPE CAP: ON EACH SIDE, bind off 3 sts. 1x, 2 sts. 2x, 1 st. 2x (24x) [26x], 2 sts. 3x, 3 sts. 1x. After Row 110 (114) [118], bind off the remaining 9 sts.

DK 303

WOMAN'S SHELL

SIZES: 6/7 (8/10) [12/14]
 YARN: Amore
 GRAMS: 150 200 250
 TENSION: 7 to 9
 GAUGE: 13 sts. 24 rows = 5 cm (2")



An Eyelet Design that follows the Line Drawing. Lower edge K1, P1 Ribbing. Straps and neck edge are Stockinette stitch.

FINISHING: See General Instructions. Make hem at neck edge. Fold straps in half, sew seam then sew to Shell. See Picture.

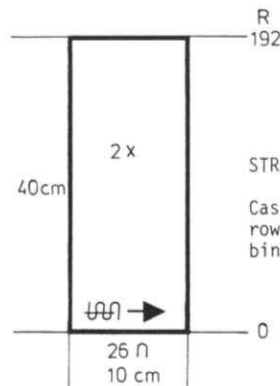

STRAPS: Make 2.

Cast on 26 sts. and work 192 rows Stockinette stitch then bind off.

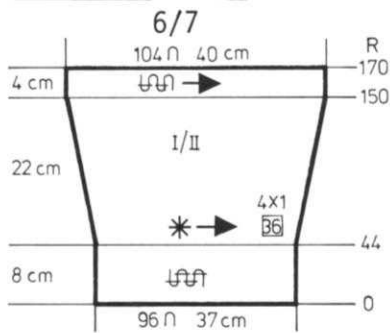

(8/10)

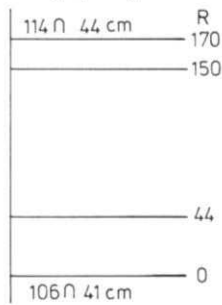

[12/14]

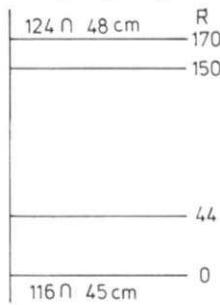

BACK & FRONT: 1/I

Cast on 96 (106) [116] sts. and work 44 rows K1, P1 Ribbing. Change to the Eyelet Design and ON EACH SIDE, increase 1 st. every 36th row 4x. After Row 150, change to Stockinette stitch and knit to Row 170. Bind off. Make 2nd section the same.

DK 304

WOMAN'S DRESS

SIZES: 8 (12) [16]
 YARN: Vienna
 GRAMS: 600 650 700
 TENSION: 6 to 8
 GAUGE: 16 sts. 28 rows = 5 cm (2")



A Holding Position Design that follows the Line Drawing. The Ribber is used and the Purl side is the right side.

FINISHING: See General Instructions. Ease the extra fullness at bustline of front section.

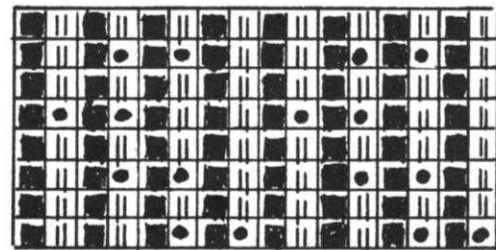

23-24
19-22
17-18
13-16
11-12
7-10
5-6
1-4

BACK: II

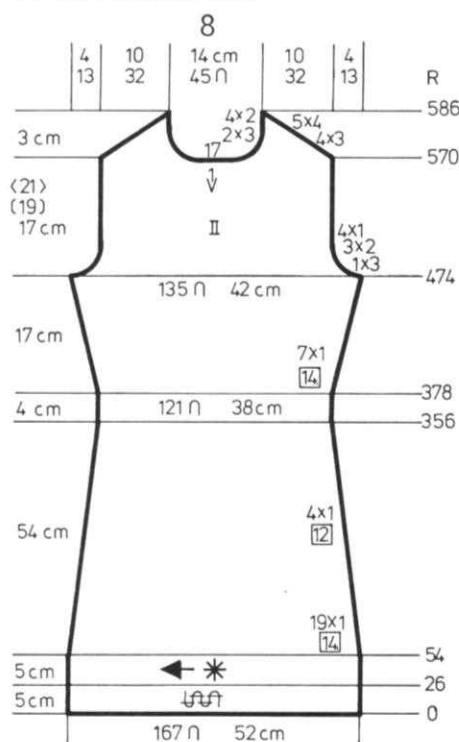

(12)

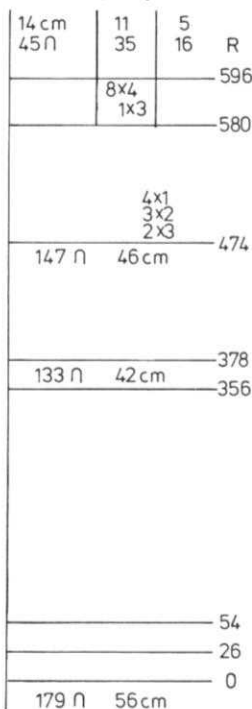

[16]

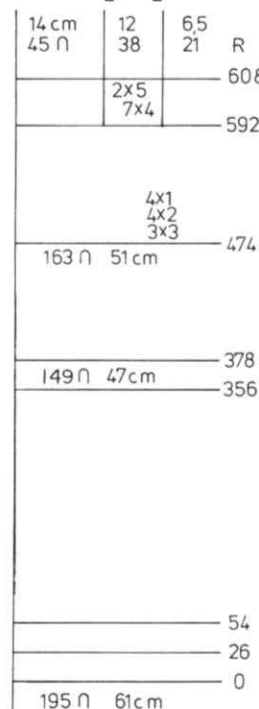

Cast on 167 (179) [195] sts. and work 26 rows K1, P1 Ribbing. Change to the Holding Position Design.

ON EACH SIDE, decrease 1 st. every 14th row 19x, every 12th row 4x.

Knit to Row 378.

ON EACH SIDE, increase 1 st. every 14th row 7x.

Knit to Row 474.

SHAPE ARMHOLE: ON EACH SIDE, bind off

3 sts. 1x, 2 sts. 3x, 1 st. 4x. (3 sts. 2x, 2 sts. 3x, 1 st. 4x). [3 sts. 3x, 2 sts. 4x, 1 st. 4x].

Knit to Row 570 (580) [592].

Bind off the center 17 sts., put the needles on the left into holding position and complete the right half first.

*SHAPE SHOULDER AND NECK AT THE SAME TIME.

FOR SHOULDER, bind off

3 sts. 4x, 4 sts. 5x.

(3 sts. 1x, 4 sts. 8x).

[4 sts. 7x, 5 sts. 2x].

FOR NECK, on all sizes, bind off

3 sts. 2x, 2 sts. 4x

Bring the needles on the left into working position, knit 1 row in Pattern to the left side, turn the Row Counter back to 570 (580) [592] and complete the left half. Follow the instructions from *.



Continued

DK 304

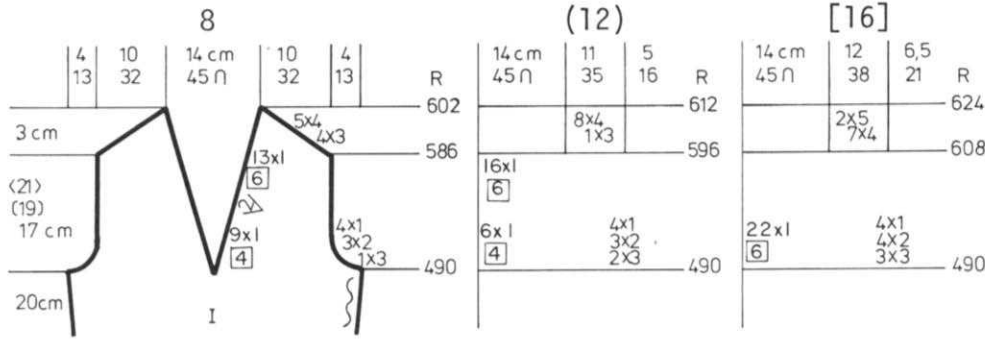

FRONT: I

Work the front the same as the back to Row 474 then knit to Row 490. Divide in the center, hang the center stitch on a neighboring needle and put the sts. on the left into holding position and complete the right half first.
*SHAPE ARMHOLE same as the back and AT THE SAME TIME, SHAPE NECK.
ON NECK SIDE, decrease 1 st. every 4th row 9x (6x) [0x], every 6th row 13x (16x) [22x] and SHAPE SHOULDER same as the back after Row 586 (596) [608].
Bring the needles on the left into working position, knit 1 row in Pattern to the left side, turn the Row Counter back to 490 and complete the left half. Follow the instructions from *.

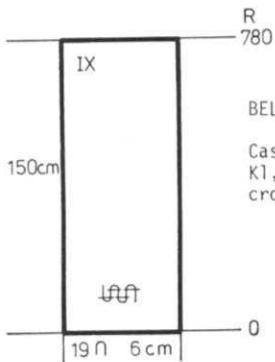

BELT: IX

Cast on 19 sts. and work 780 rows K1, P1 Ribbing then bind off the crochet method for Ribbing.

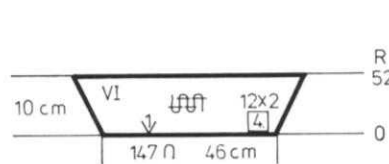

BACK NECKBAND: VI

Cast on 147 sts. and work K1, P1 Ribbing.
ON EACH SIDE, on every 4th row, increase 2 sts. 12x. After Row 52, bind off the crochet method for Ribbing.

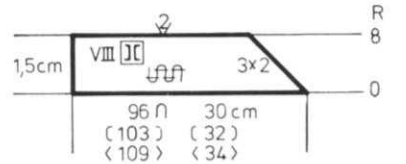

FRONT NECKBANDS: VIII Make 1 reverse 1.

Cast on 96 (103) [109] sts. and work K1, P1 Ribbing.
On the RIGHT (left for 2nd section) on every 2nd row, decrease 2 sts. 3x. After Row 8, bind off the crochet method for Ribbing.

SLEEVE: III

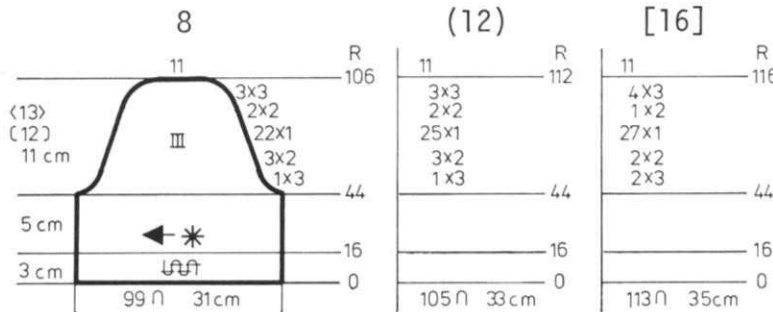

Cast on 99 (105) [113] sts. and work 16 rows K1, P1 Ribbing.
Change to the Holding Position Design and knit to Row 44.
SHAPE CAP: ON EACH SIDE, bind off 3 sts. 1x, 2 sts. 3x, 1 st. 22x, 2 sts. 2x, 3 sts. 3x.
(3 sts. 1x, 2 sts. 3x, 1 st. 25x, 2 sts. 2x, 3 sts. 3x).
[3 sts. 2x, 2 sts. 2x, 1 st. 27x, 2 sts. 1x, 3 sts. 4x].
After Row 106 (112) [116], bind off the remaining 11 sts.



DK 305

WOMAN'S BLOUSE

SIZES: 6/7 (8/10) [12/14]
YARN: Amore
GRAMS: 250 300 350
TENSION: 9 to 10
GAUGE: 13 sts. 22 rows = 5 cm (2")

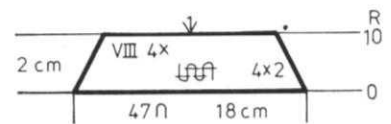

NECKBAND: VIII Make 4.

Cast on 47 sts. and work K1, P1 Ribbing. ON EACH SIDE, on every 2nd row, bind off 2 sts. 4x.
After Row 10, bind off the remaining sts. the crochet method.

An Eyelet Design that follows the Line Drawing. Bands are K1, P1 Ribbing.

FINISHING: See General Instructions.

BACK: II

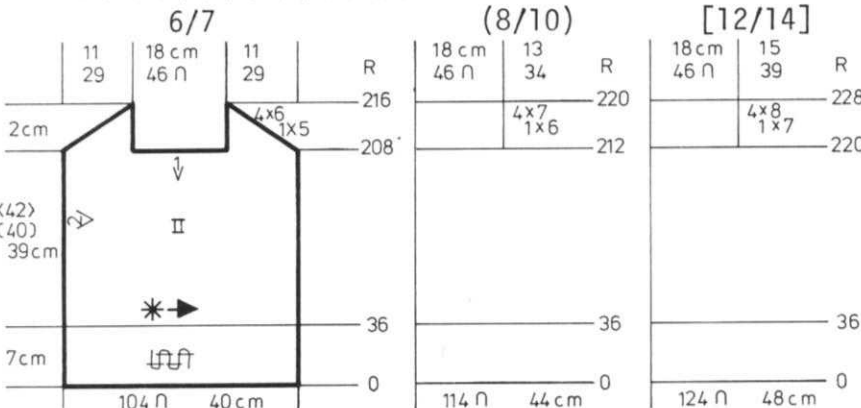

Cast on 104 (114) [124] sts. and work 36 rows K1, P1 Ribbing.
Change to the Eyelet Design.
Knit to Row 208 (212) [220].
Bind off the center 46 sts., put the needles on the left into holding position and complete the right half first.
*SHAPE SHOULDER, bind off 5 sts. 1x, 6 sts. 4x.
(6 sts. 1x, 7 sts. 4x).
[7 sts. 1x, 8 sts. 4x].
Bring the needles on the left into working position, knit 1 row in Pattern to the left side, turn the Row Counter back to 208 (212) [220] and complete the left half.
Follow the instructions from *.

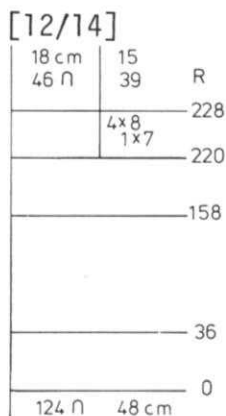
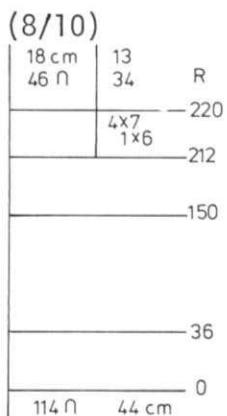
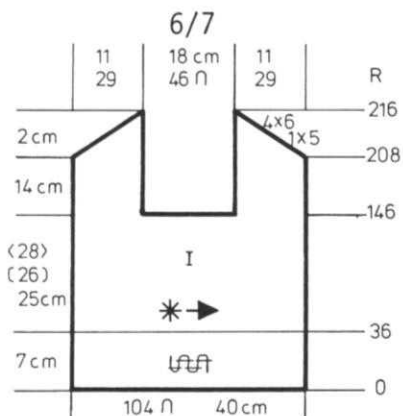

FRONT: I

Cast on 104 (114) [124] sts. and work 36 rows K1, P1 Ribbing. Change to the Eyelet Design. Knit to Row 146 (150) [158]. Bind off the center 46 sts., put the needles on the left into holding position and complete the right half first. *Knit to Row 208 (212) [220]. SHAPE SHOULDER same as the back. Bring the needles on the left into working position, knit 1 row in Pattern to the left side, turn the Row Counter back to 208 (212) [220] and complete the left half. Follow the instructions from *.

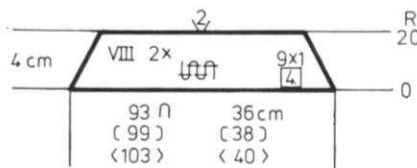

ARMBANDS: VIII Make 2.

Cast on 93 (99) [103] sts. and work K1, P1 Ribbing. ON EACH SIDE, on every 4th row, decrease 1 st. 9x. After Row 20, bind off the crochet method for Ribbing.

DK 306

WOMAN'S JACKET

SIZES: 8/10 (12/14) [16]
YARN: Crocus Crepe
GRAMS:
color 1 300 350 400
color 2 100 100 100
TENSION: 6 to 8
GAUGE: 14 sts. 22 rows = 5 cm (2")

Stockinette stitch with color stripes as shown on the Chart. Bands are K1, P1 Ribbing.

FINISHING: See General Instructions.

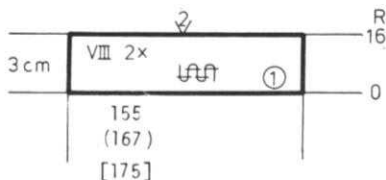

FRONT BANDS: VIII Make 2.

Cast on 155 (167) [175] sts. with color 1 and work 16 rows K1, P1 Ribbing then bind off the crochet method for Ribbing.

BACK: II

Cast on 129 (141) [151] sts. with color 1 and work 16 rows K1, P1 Ribbing. Change to Stockinette stitch and work the color stripes as shown on the Chart. ON EACH SIDE, decrease 1 st. every 18th row 7x. Knit to Row 140. ON EACH SIDE, increase 1 st. every 20th row 4x. Knit to Row 224. SHAPE ARMHOLE: ON EACH SIDE, bind off 3 sts. 2x, 2 sts. 2x, 1 st. 4x. (3 sts. 2x, 2 sts. 3x, 1 st. 5x). [3 sts. 2x, 2 sts. 4x, 1 st. 6x]. Knit to Row 304 (308) [316]. Bind off the center 17 sts., put the needles on the left into holding position and complete the right half first. *SHAPE SHOULDER AND NECK AT THE SAME TIME. FOR SHOULDER, bind off 3 sts. 2x, 4 sts. 4x. (4 sts. 5x, 5 sts. 1x). [4 sts. 3x, 5 sts. 3x]. FOR NECK, on all sizes, bind off 3 sts. 3x, 4 sts. 2x. Move the Cam Box to the left side, turn the Row Counter back to 304 (308) [316] and complete the left half. Follow the instructions from *.

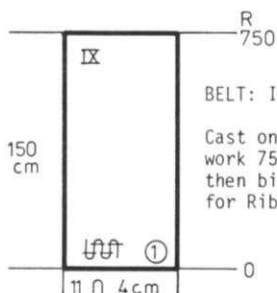
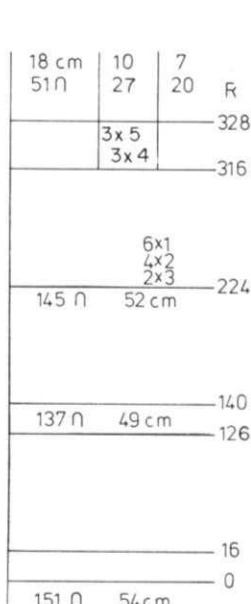
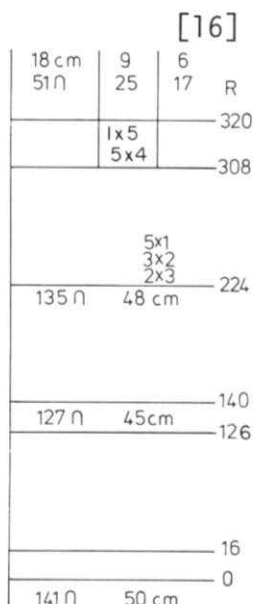
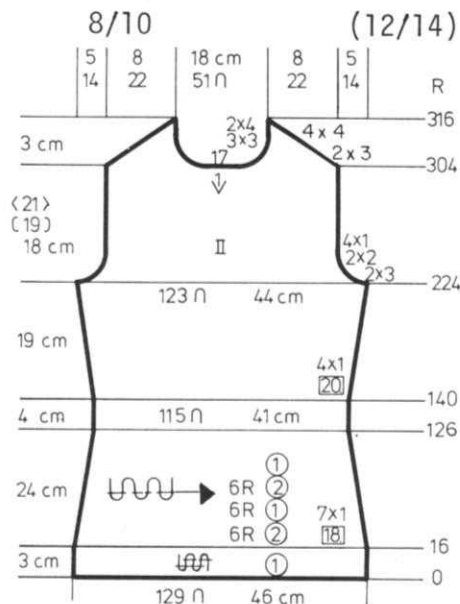

BELT: IX

Cast on 11 sts. with color 1 and work 750 rows K1, P1 Ribbing then bind off the crochet method for Ribbing.

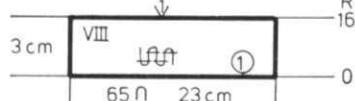

BACK NECKBAND: VIII

Cast on 65 sts. with color 1 and work 16 rows K1, P1 Ribbing, then bind off the crochet method for Ribbing.

Continued



DK 306

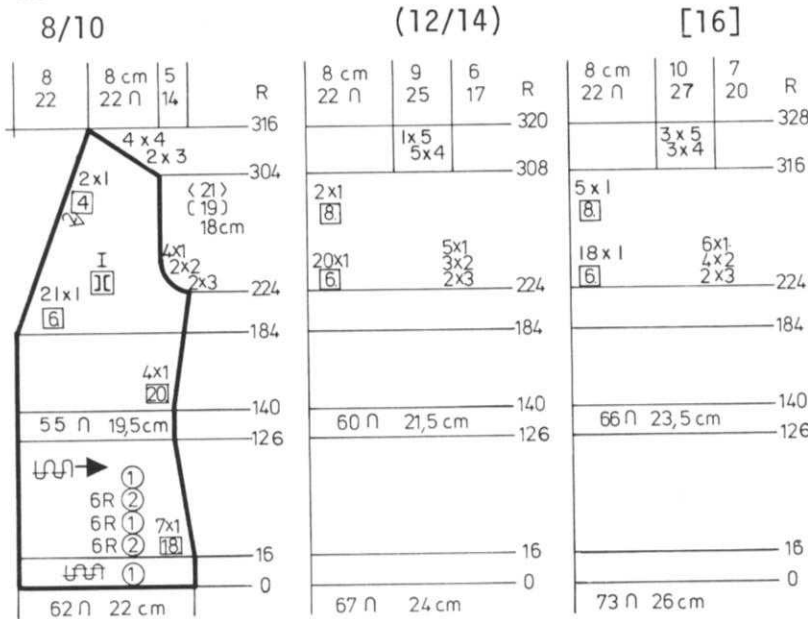

FRONT: I Make 1, reverse 1.

Cast on 62 (67) [73] sts. with color 1 and work 16 rows K1, P1 Ribbing. Change to Stockinette stitch and color stripes as shown on the Chart.
 ON SIDE EDGE, decrease 1 st. every 18th row 7x.
 Knit to Row 140.
 ON SIDE EDGE, increase 1 st. every 20th row 4x.
 Knit to Row 184.
 SHAPE FRONT: ON NECK SIDE, decrease 1 st. every 6th row 21x (20x) [18x], every 4th row 2x (every 8th row 2x) [every 8th row 5x] and AT THE SAME TIME, after Row 224, SHAPE ARMHOLE same as the back and SHAPE SHOULDER same as the back after Row 304 (308) [316].
 Work the 2nd front section with reverse shaping, casting on from RIGHT to LEFT. Cam Box will be on the LEFT side at Row 0.

SLEEVES: III

Cast on 95 (101) [107] sts. with color 1 and work 10 rows K1, P1 Ribbing. Change to Stockinette stitch and work the color stripes as shown on the Chart.
 Knit to Row 24.
 SHAPE CAP: ON EACH SIDE, bind off 3 sts. 2x *2 sts. 1x, 1 st. 2x and REPEAT from * 5x more, 3 sts. 4x. (3 sts. 2x *2 sts. 1x, 1 st. 2x, and REPEAT from * 6x more, 3 sts. 1x, 4 sts. 2x).
 [3 sts. 2x, *2 sts. 1x, 1 st. 2x and REPEAT from * 7x more, 3 sts. 2x, 4 sts. 1x].
 After Row 72 (76) [82], bind off the remaining 11 sts.

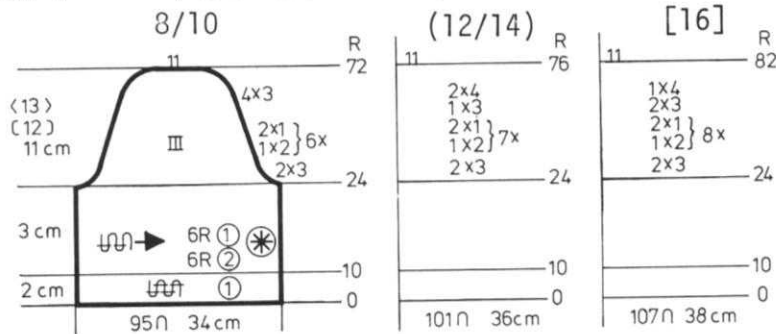

DK 307

WOMAN'S JACKET

SIZES: 6/8 (10/12) [14/16] Stockinette stitch with REPEATED color stripes on the yoke section as shown on the Chart.
 YARN: Binia
 GRAMS: color 1 250 300 350 Bands are K1, P1 Ribbing. Worn on the Purl side.
 color 2 50 100 100
 TENSION: 8 to 10
 GAUGE: 13 sts. 18 rows = 5 cm (2") FINISHING: See General Instructions.

BACK: II

Cast on 98 (108) [118] sts. with color 1 and work 22 rows K1, P1 Ribbing.
 Change to Stockinette stitch.
 Knit to Row 90.
 SHAPE SLEEVE: ON EACH SIDE, cast on 1 st. 3x, 2 sts. 2x, 3 sts. 2x, 13 sts. 1x.
 After Row 104, work the REPEATED color stripes as shown on the Chart.
 Knit to Row 166 (170) [172].
 Bind off the center 22 sts., put the needles on the left into holding position and complete the right half first.
 *SHAPE SHOULDER AND NECK AT THE SAME TIME.
 FOR SHOULDER, bind off 8 sts. 2x, 9 sts. 4x. (9 sts. 3x, 10 sts. 3x). [10 sts. 4x, 11 sts. 2x].
 FOR NECK, on all sizes, bind off 3 sts. 4x.
 Bring the needles on the left into working position, knit 1 row to the left side, turn the Row Counter back to 166 (170) [172] and complete the left half. Follow the instructions from *.

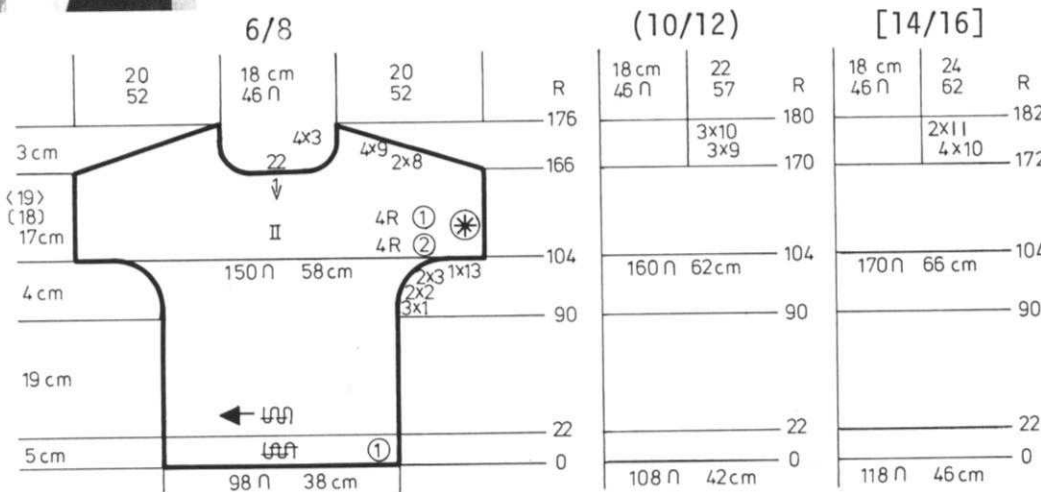

FRONT: I Make 1, reverse 1.

DO NOT MAKE BUTTONHOLES IN THIS SECTION.
Cast on 60 (65) [70] sts. with color 1 and work K1, P1 Ribbing with 16 sts. on the LEFT (right for 2nd section) in Stockinette stitch. Knit to Row 22 then change to Stockinette stitch and knit to Row 90.

SHAPE SLEEVE same as the back.
After Row 104, put 16 sts. on the LEFT (right for 2nd section) into holding position and work the REPEATED color stripes as shown on the Chart.
ON NECK SIDE, decrease 1 st. every 4th row 18x (every 4th row 16x, every 6th row 2x) [every 4th row 15x, every 6th row 3x] AND AT THE SAME TIME, after Row 166 (170) [172], SHAPE SHOULDER same as the back.
Bring the 16 sts. on the left (right) into working position, turn the Row Counter back to 104 and continue the band with color 1 and Stockinette stitch to Row 212 (216) [218], then bind off.
Work the 2nd section with reverse shaping, casting on from RIGHT TO LEFT. Cam Box will be on the LEFT side at Row 0 and make BUTTONHOLES over needles 2 to 6 and 10 to 14 counting from the right edge, after the rows shown on the Chart.

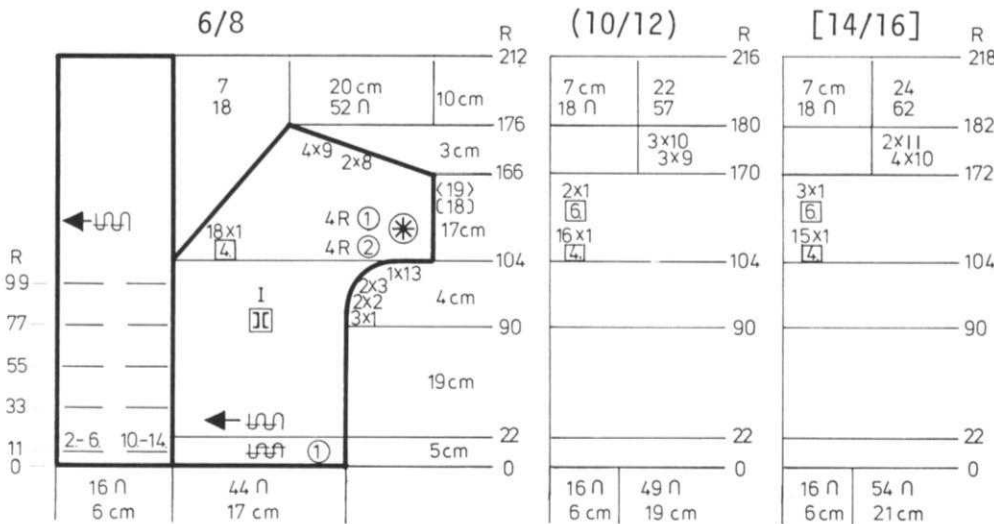

DK 308

WOMAN'S COAT

SIZES: 10/12 (14/16) [18/20]

YARN: Euro Sport

GRAMS:

color 1 600 700 800

color 2 250 300 350

TENSION: 9 or 10

GAUGE: 12 sts. 18 rows = 5 cm (2")

Stockinette stitch with color stripes as shown on the Chart.
Worn on the Purl side.

FINISHING: See General Instructions. Fold waistline casing in half with purl sides together. Sew center of casing at waistline, then unfold and sew each edge to Coat. See picture.

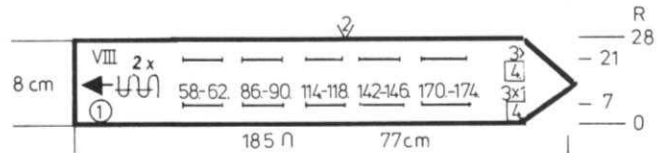

FRONT BANDS: Make 2 and omit Buttonholes in 2nd section.

Cast on 185 sts. with color 1 and work Stockinette stitch. ON ONE SIDE ONLY, work the shaping same as the Neckband and AT THE SAME TIME, make BUTTONHOLES after Row 7 and 21 over the needles as shown on Chart. After Row 28, bind off.

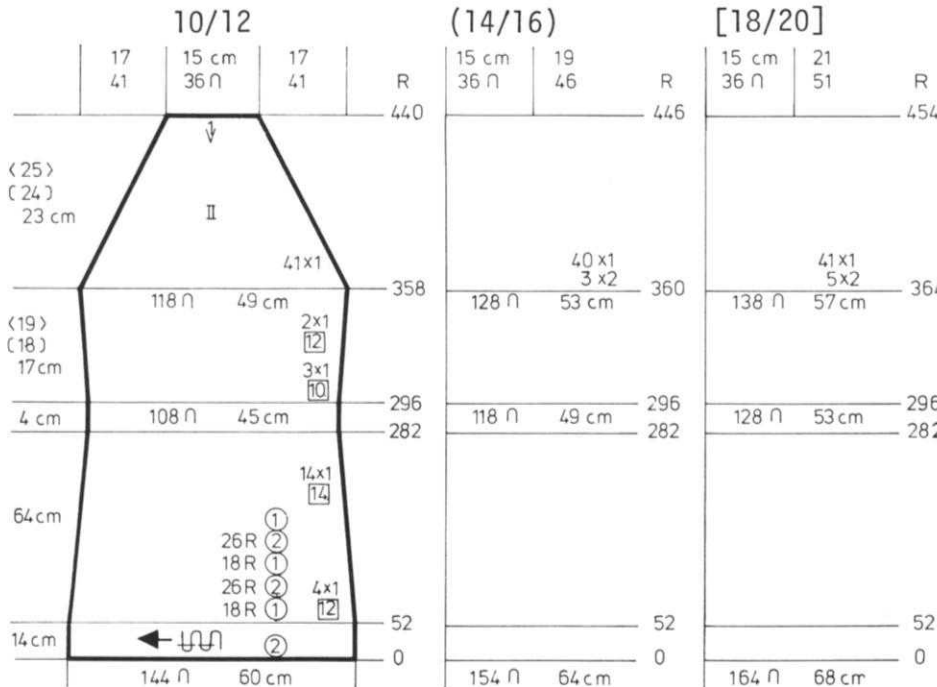

BACK: II

Cast on 144 (154) [164] sts. with color 2 and work Stockinette stitch to Row 52.
Work the color stripes as shown on the Chart and ON EACH SIDE, decrease 1 st. every 12th row 4x, every 14th row 14x. Knit to Row 296.
ON EACH SIDE, increase 1 st. every 10th row 3x, every 12th row 2x.
Knit to Row 358 (360) [364].
SHAPE RAGLAN: ON EACH SIDE, on every 2nd row, decrease 1 st. 41x.
(decrease 2 sts. 3x, 1 st. 40x). [decrease 2 sts. 5x, 1 st. 41x].
After Row 440 (446) [454], bind off the remaining 36 sts.

DK 309

WOMAN'S JACKET

SIZES: 6/8 (10/12) [14/16]
 YARN: Allegro
 GRAMS: 550 600 650
 TENSION: 7 to 9
 GAUGE: 14 sts. 19 rows = 5 cm (2")

Stockinette stitch worn on the Purl side. Front, sleeve and hood bands are Stockinette stitch on the knit side.

FINISHING: See General Instructions. Sew hood seam then sew to neckline of jacket. Sew short ends of hood band together then sew 1 edge to the inside and 1 to outside of hood. Make a cord over 5 needles long enough to go through casing of hood band and tie.

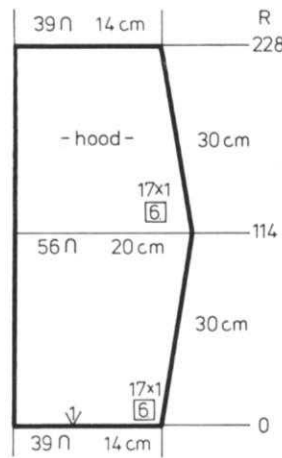

HOOD:

Cast on 39 sts. and work Stockinette stitch.
 ON THE RIGHT, increase 1 st. every 6th row 17x.
 After Row 114, decrease 1 st. every 6th row 17x.
 After Row 228, bind off.

BACK: II

Cast on 123 (135) [145] sts. and work Stockinette stitch.
 Knit to Row 160.
 SHAPE ARMHOLE: ON EACH SIDE, bind off
 3 sts. 1x, 2 sts. 2x, 1 st. 4x.
 (3 sts. 1x, 2 sts. 3x, 1 st. 5x).
 [3 sts. 2x, 2 sts. 2x, 1 st. 6x].
 Knit to Row 232 (236) [240].
 Bind off the center 19 sts., put the needles on the left into holding position and complete the right half first.
 *SHAPE SHOULDER AND NECK AT THE SAME TIME.
 FOR SHOULDER, bind off
 3 sts. 3x, 4 sts. 4x.
 (4 sts. 7x).
 [4 sts. 4x, 5 sts. 3x].
 FOR NECK, on all sizes, bind off 4 sts. 4x.
 Move the Cam Box to the left side, turn the Row Counter back to 232 (236) [240] and complete the left half. Follow the instructions from *.

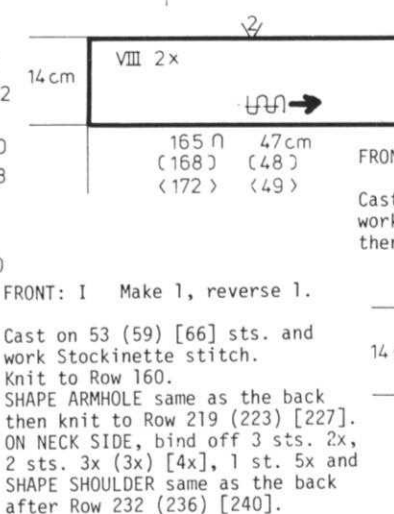
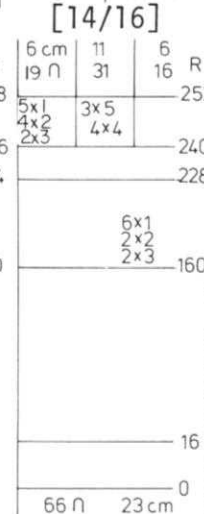
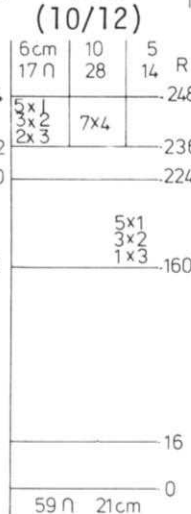
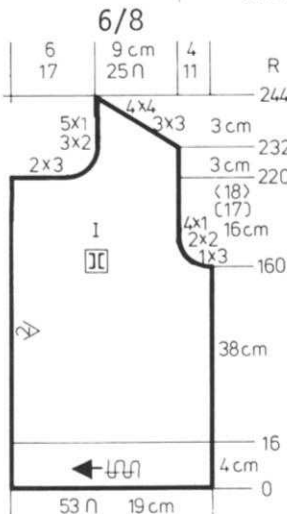
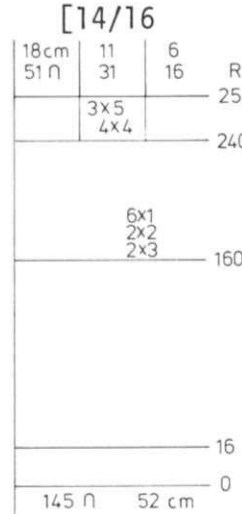
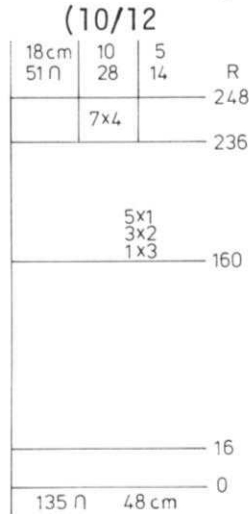
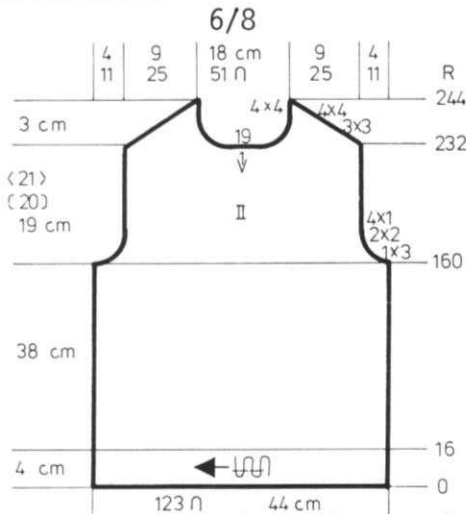

FRONT BANDS: VIII Make 2.

Cast on 165 (168) [172] sts. and work 54 rows Stockinette stitch then bind off.

FRONT: I Make 1, reverse 1.

Cast on 53 (59) [66] sts. and work Stockinette stitch.
 Knit to Row 160.
 SHAPE ARMHOLE same as the back then knit to Row 219 (223) [227].
 ON NECK SIDE, bind off 3 sts. 2x, 2 sts. 3x (3x) [4x], 1 st. 5x and SHAPE SHOULDER same as the back after Row 232 (236) [240].

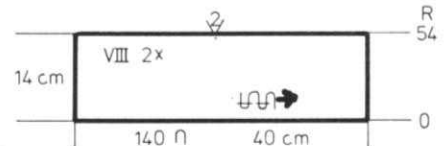

HOOD BANDS: Make 2.

Cast on 140 sts. and work 54 rows Stockinette stitch then bind off.

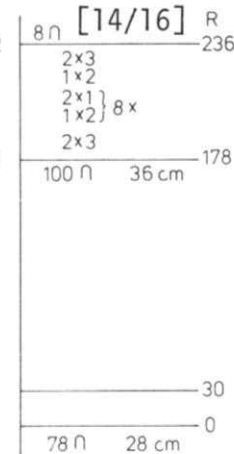
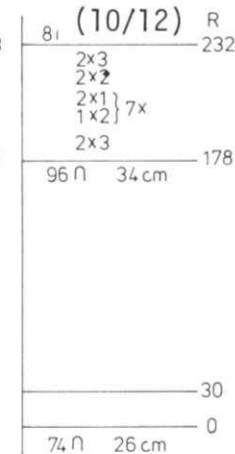
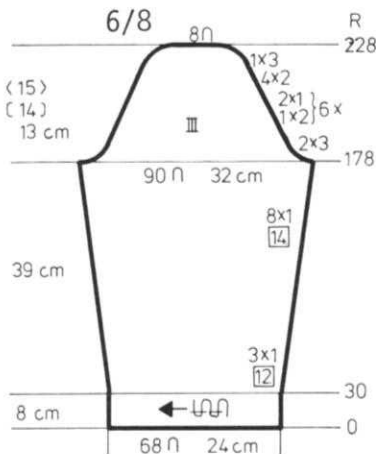

SLEEVES: III

Cast on 68 (74) [78] sts. and work Stockinette stitch.
 After Row 30, ON EACH SIDE, increase 1 st. every 12th row 3x, every 14th row 8x.
 Knit to Row 178.
 SHAPE CAP: ON EACH SIDE, bind off 3 sts. 2x, 2 sts. 1x, 1 st. 2x and REPEAT from * 5x more, 2 sts. 4x, 3 sts. 1x.
 (3 sts. 2x, *2 sts. 1x, 1 st. 2x and REPEAT from * 6x more, 2 sts. 2x, 3 sts. 2x).
 [3 sts. 2x, *2 sts. 1x, 1 st. 2x and REPEAT from * 7x more, 2 sts. 1x, 3 sts. 2x].
 After Row 228 (232) [236], bind off the remaining 8 sts.

DK 310

WOMAN'S PULLOVER

SIZES: 6/8 (10/12) [14/16]

YARN: Vienna

GRAMS:
 color 1 150 200 250
 color 2 100 150 150
 color 3 100 150 150

TENSION: 5 to 7

GAUGE: 15 sts. 20 rows = 5 cm (2")

A Norwegian Design with color stripes as shown on the Chart.

FINISHING: See General Instructions.
 Ease the extra fullness on top of sleeve cap

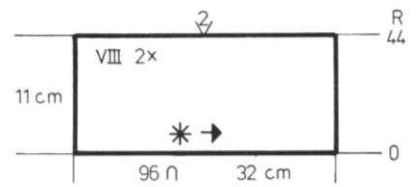
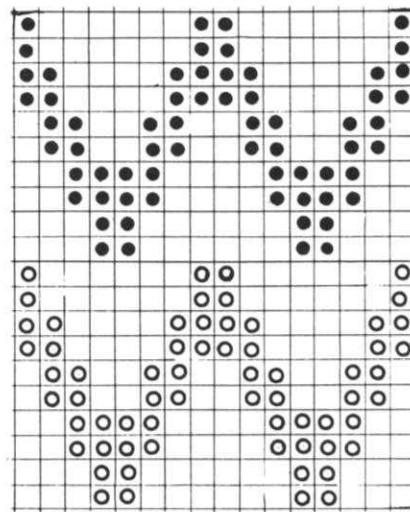

SLEEVE BANDS: VIII Make 2.

Cast on 96 sts. with color 1 and work the Norwegian Design. Knit to Row 44 then bind off.

● color 3
 ○ color 2
 □ color 1

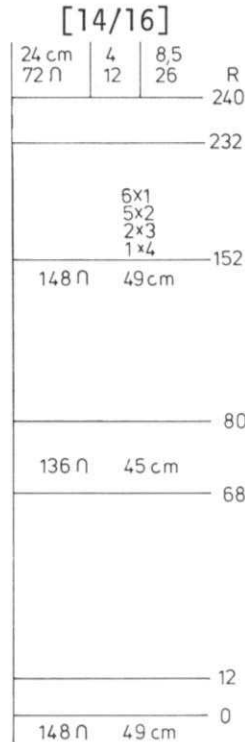
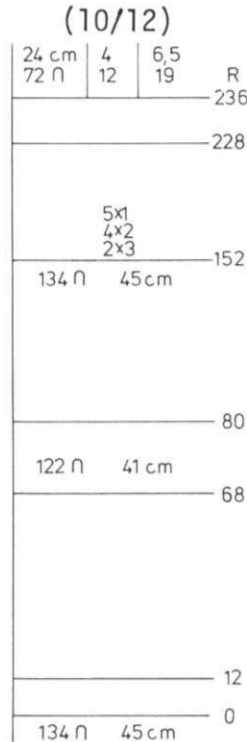
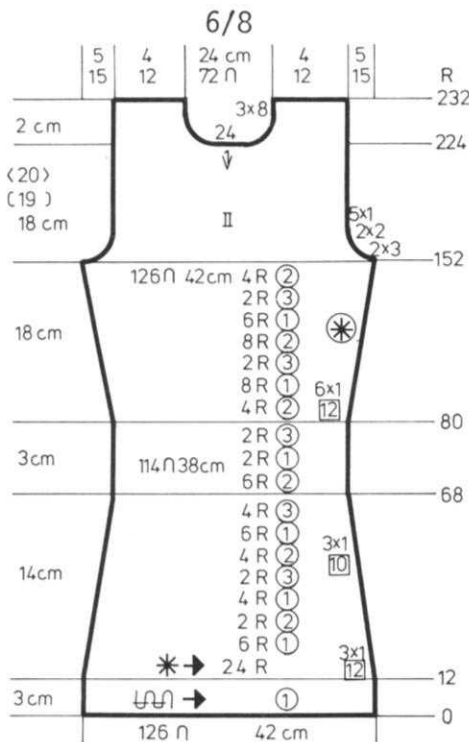

BACK: II

Cast on 126 (134) [148] sts. with color 1 and work 12 rows Stockinette stitch.
 Change to Pattern and REPEATED color stripes as shown on the Chart. ON EACH SIDE, decrease 1 st. every 12th row 3x, every 10th row 3x. Knit to Row 80.
 ON EACH SIDE, increase 1 st. every 12th row 6x.
 Knit to Row 152.
 SHAPE ARMHOLE: ON EACH SIDE, bind off 3 sts. 2x, 2 sts. 2x, 1 st. 5x. (3 sts. 2x, 2 sts. 4x, 1 st. 5x). [4 sts. 1x, 3 sts. 2x, 2 sts. 5x, 1 st. 6x].
 Knit to Row 224 (228) [232]. Bind off the center 24 sts., put the needles on the left into holding position and complete the right half first.
 *ON NECK SIDE, for all sizes, bind off 8 sts. 3x.
 Bind off the remaining 12 sts. Bring the needles on the left into working position, knit 1 row in Pattern to the left side, turn the Row Counter back to 224 (228) [232] and complete the left half. Follow the instructions from *.

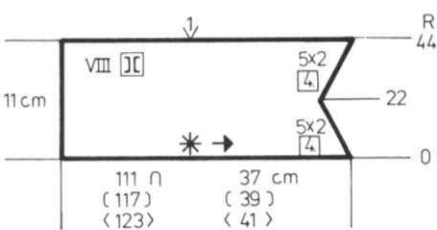

NECKBAND: VIII Make 1, reverse 1.

Cast on 111 (117) [123] sts. with color 1 and work the Norwegian Design. ON THE RIGHT (left for 2nd section) on every 4th row, decrease 2 sts. 5x.
 After Row 22, ON THE RIGHT (left for 2nd section) on every 4th row, increase 2 sts. 5x.
 After Row 44, bind off.

FRONT: I

Work the front the same as the back to Row 152.
 Divide in the center, put the needles on the left into holding position and complete the right half first.
 *SHAPE ARMHOLE same as the back and AT THE SAME TIME, SHAPE NECK: ON NECK SIDE, decrease 1 st. every 2nd row 33x, every 4th row 3x. After Row 232 (236) [240], bind off the remaining 12 sts. Bring the needles on the left into working position, knit 1 row in Pattern to the left side, turn the Row Counter back to 152 and complete the left half. Follow the instructions from *.

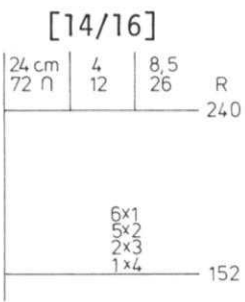
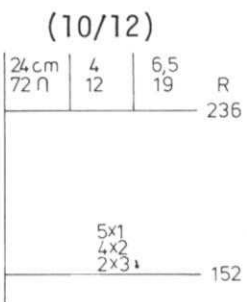
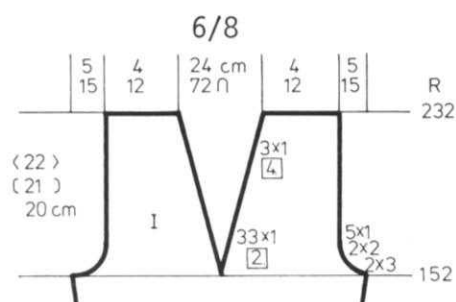

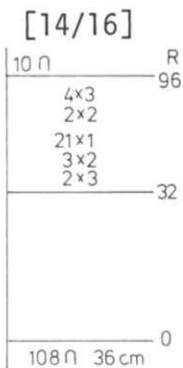
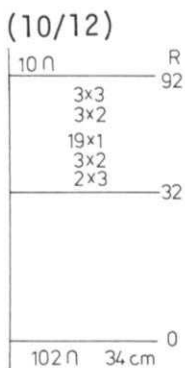
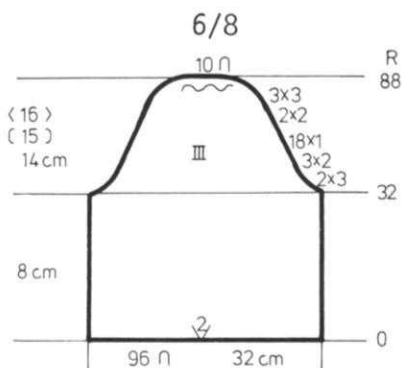

SLEEVE: VIII

Cast on 96 (102) [108] sts. with color 1 and work Stockinette stitch with stripes to match the colors below the armholes on front and back sections. Knit to Row 32. SHAPE CAP: ON EACH SIDE, bind off 3 sts. 2x, 2 sts. 3x, 1 st. 18x (19x), [21x], 2 sts. 2x (3x) [2x], 3 sts. 3x (3x) [4x]. After Row 88 (92) [96], bind off the remaining 10 sts.

DK 311



WOMAN'S 2 PIECE DRESS

SIZES: 10/12 (14) [16/18]

YARN:
color 1 Micaela
color 2 Monofil
GRAMS:
color 1 450 500 550
color 2 1 spool for all sizes.
TENSION: 4 to 6
GAUGE: 15 sts. 20 rows = 5 cm (2")

Norwegian Technique that follows the Line Drawing or you may punch your own card. Belt, bands and neckline insert are K1, P1 Ribbing.

FINISHING: See General Instructions. Ease the extra fullness at bustline of front section. Sew insert to front neckline.

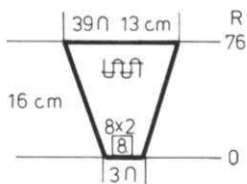

NECK INSERT:

Cast on 3 sts. and work K1, P1 Ribbing. ON EACH SIDE, increase 2 sts. every 8th row 8x. After Row 76, bind off the crochet method for Ribbing.

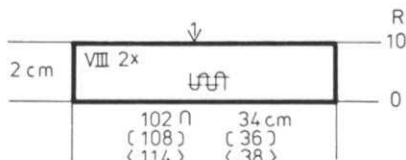

NECKBAND: VIII Make 2.

Cast on 102 (108) [114] sts. and work 10 rows K1, P1 Ribbing then bind off the crochet method for Ribbing.

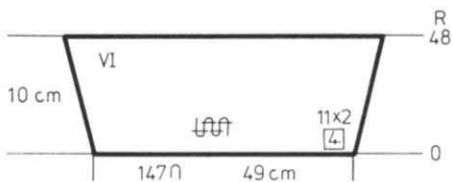

COLLAR: VI

Cast on 147 sts. and work K1, P1 Ribbing. ON EACH SIDE, increase 2 sts. every 4th row 11x. After Row 48, bind off the crochet method for Ribbing.

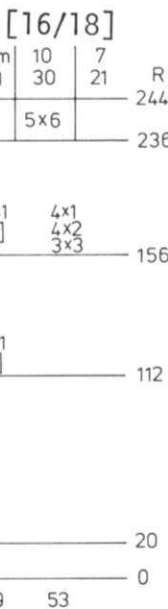
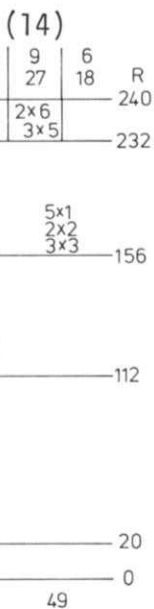
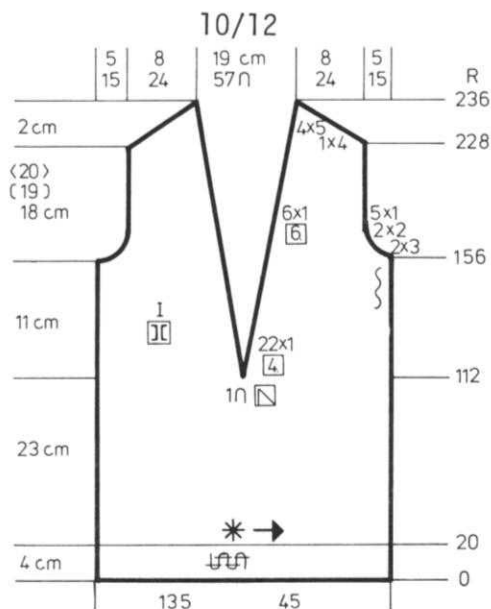

BLOUSE BACK: II

Cast on 135 (147) [159] sts. and work 20 rows K1, P1 Ribbing. Change to Pattern. Knit to Row 144. SHAPE ARMHOLE: ON EACH SIDE, bind off 3 sts. 2x, 2 sts. 2x, 1 st. 5x. (3 sts. 3x, 2 sts. 2x, 1 st. 5x). [3 sts. 3x, 2 sts. 4x, 1 st. 4x]. Knit to Row 216 (220) [224]. Bind off the center 21 sts., put the needles on the left into holding position and complete the right half first. *SHAPE SHOULDER AND NECK AT THE SAME TIME. FOR SHOULDER, bind off 4 sts. 1x, 5 sts. 4x. (5 sts. 3x, 6 sts. 2x). [6 sts. 5x]. FOR NECK, on all sizes, bind off 6 sts. 3x. Bring the needles on the left into working position, knit 1 row in Pattern to the left side, turn the Row Counter back to 216 (220) [224] and complete the left half. Follow the instructions from *.



Continued

DK 311

SLEEVE: III

Cast on 60 (66) [72] sts. and work 38 rows K1, P1 Ribbing. Change to Pattern. ON EACH SIDE, increase 1 st. every 8th row 18x. Knit to Row 182.

SHAPE CAP: ON EACH SIDE, bind off 3 sts. 1x, 2 sts. 2x *1 st. 2x, 2 sts. 1x, and REPEAT from * 5x more, 3 sts. 1x, 4 sts. 2x. (3 sts. 3x, *1 st. 2x, 2 sts. 1x, and REPEAT from * 6x more, 4 sts. 2x). [3 sts. 1x, 2 sts. 2x, *1 st. 2x, 2 sts. 1x, and REPEAT from * 6x more, 3 sts. 3x, 4 sts. 1x]. After Row 230 (234) [238], bind off the remaining 12 sts.

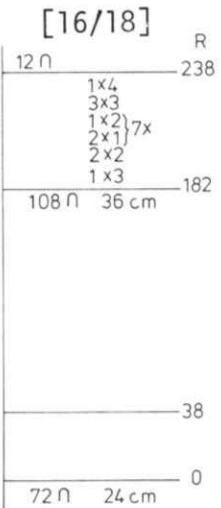
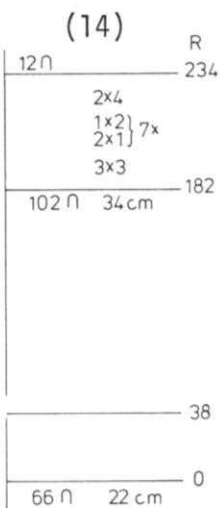
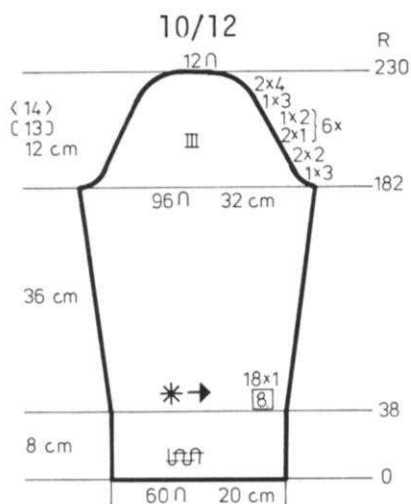

FRONT: I

Cast on 135 (147) [159] sts. and work 20 rows K1, P1 Ribbing. Change to Pattern. Knit to Row 112.

Hang the center stitch onto the neighboring needle, put all the needles on the left into holding position and complete the right half first.

*SHAPE NECK: ON NECK SIDE, decrease 1 st. every 4th row 22x (20x) [18x], every 6th row 6x (8x) [10x] and AT THE SAME TIME, SHAPE ARMHOLE same as the back after Row 156 and SHAPE SHOULDER same as the back after Row 228 (232) [236].

Bring the needles on the left into working position, knit 1 row in Pattern to the left side, turn the Row Counter back to 112 and complete the left half. Follow the instructions from *.

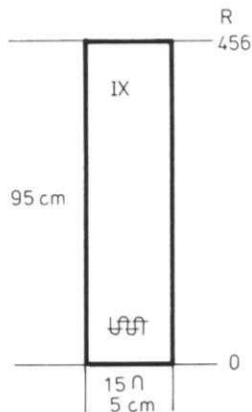
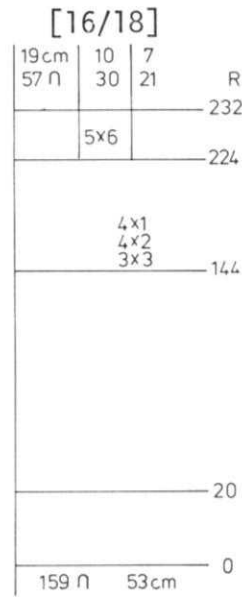
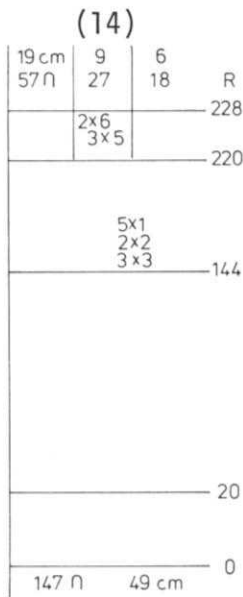
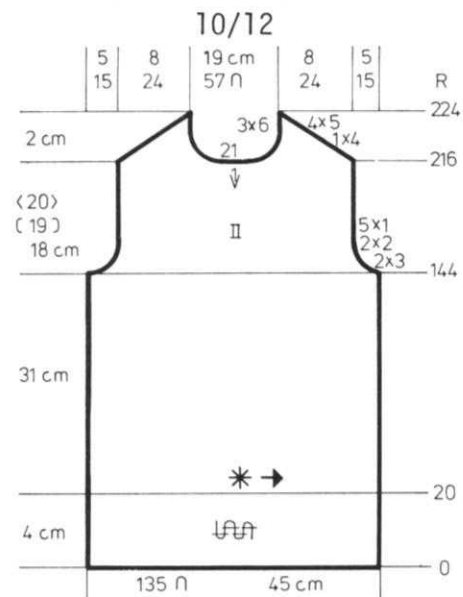

BELT: IX

Cast on 15 sts. and work 456 rows K1 P1 Ribbing then bind off the crochet method for Ribbing.

SKIRT: V Make 4.

Cast on 82 (92) [102] sts. and work in Pattern. After Row 32, ON EACH SIDE, decrease 1 st. every 30th row 6x. After Row 196, ON EACH SIDE, decrease 1 st. every 8th row 9x. After Row 300, bind off the remaining 52 (62) [72] sts.

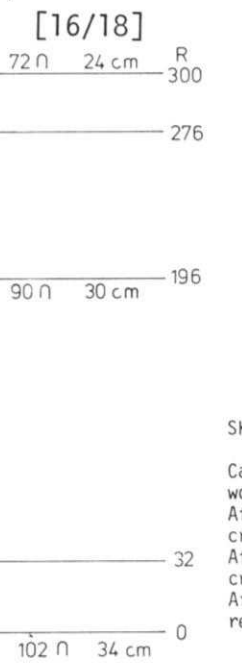
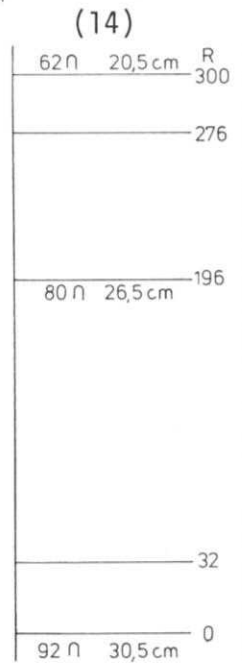
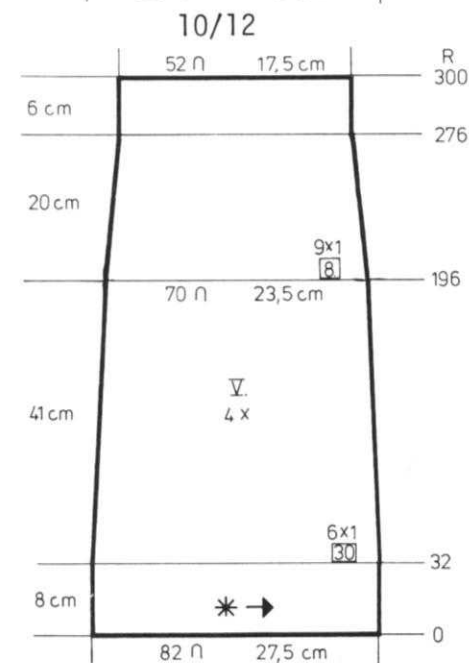

DK 312

WOMAN'S PULLOVER & SKIRT

SIZES: 6/7 (8/10) [12/14]
 YARN: Crocus
 GRAMS: 600 650 700
 TENSION: 6 to 8
 GAUGE: 12 sts. 20 rows = 5 cm (2")

Stockinette stitch. The skirt is knitted sideways on the machine.

FINISHING: See General Instructions.
 Skirt: Weave the open sts. held on contrast yarn then remove the waste yarn. Hem lower edge and make hem at waistline then insert elastic through casing.

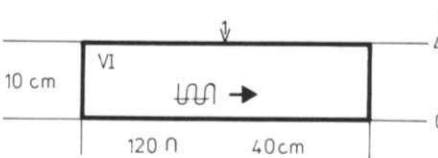
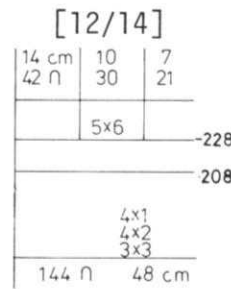
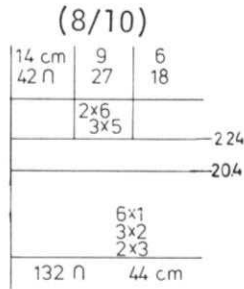
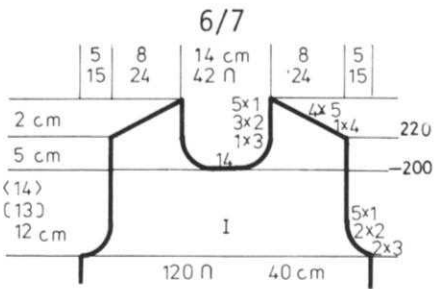
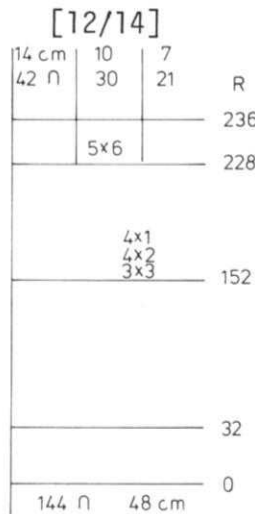
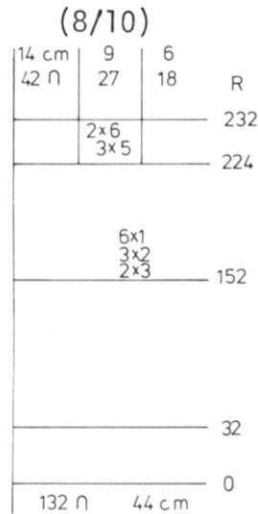
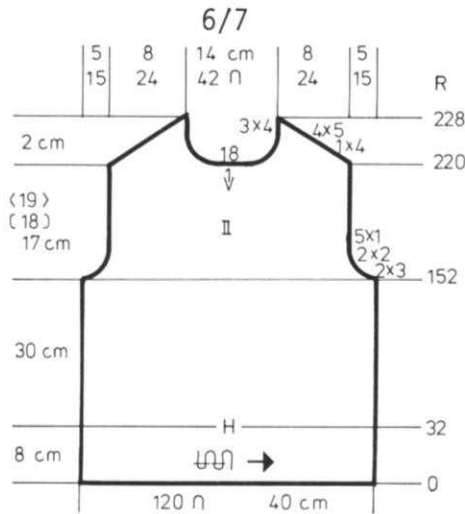

NECKBAND: VI

Cast on 120 sts. and work 40 rows Stockinette stitch then bind off.



6/7

(8/10)

[12/14]

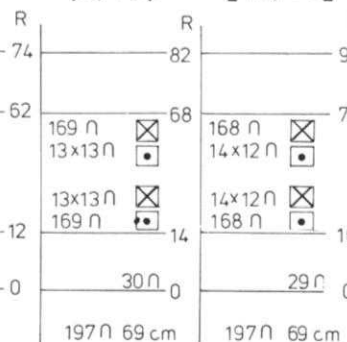
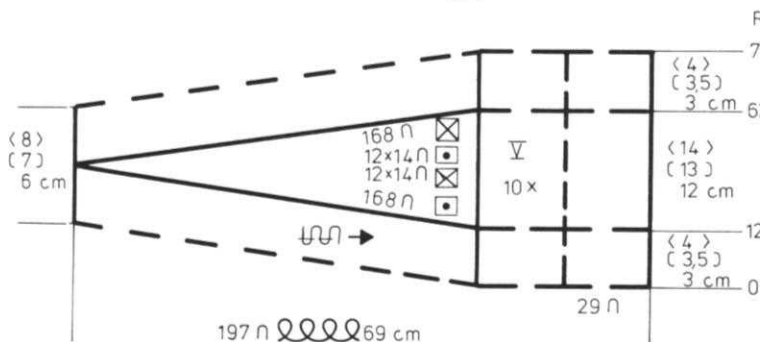

PULLOVER BACK: II

Cast on 120 (132) [144] sts. and work Stockinette stitch. Knit to Row 32, then hang the hem. Knit to Row 152.

SHAPE ARMHOLE: ON EACH SIDE, bind off

3 sts. 2x, 2 sts. 2x, 1 st. 5x. (3 sts. 2x, 2 sts. 3x, 1 st. 6x). [3 sts. 3x, 2 sts. 4x, 1 st. 4x]. Knit to Row 220 (224) [228]. Bind off the center 18 sts., put the needles on the left into holding position and complete the right half first.

*SHAPE SHOULDER AND NECK AT THE SAME TIME.

FOR SHOULDER, bind off

4 sts. 1x, 5 sts. 4x. (5 sts. 3x, 6 sts. 2x). [6 sts. 5x].

FOR NECK, on all sizes, bind off 4 sts. 3x.

Move the Cam Box to the left side, turn the Row Counter back to 220 (224) [228] and complete the left half. Follow the instructions from *.

FRONT: I

Work the front the same as the back to Row 200 (204) [208].

Bind off the center 14 sts., put the needles on the left into holding position and complete the right half first.

ON NECK SIDE, for all sizes, bind off 3 sts. 1x, 2 sts. 3x, 1 st. 5x and SHAPE SHOULDER same as the back after Row 220 (224) [228].

Move the Cam Box to the left side, turn the Row Counter back to 200 (204) [208] and complete the left half. Follow the instructions from *.

SKIRT: V

OPEN CAST ON with Waste yarn. Cast on 197 sts. and work 8 to 10 rows with waste yarn. Change to garment yarn and work Stockinette stitch with SHORT ROWS. Counter at 0. *Knit to Row 12 (14) [16].

ON OPPOSITE SIDE OF CAM BOX, put into holding position 168 (169) [168] sts., knit 2 rows.

ON OPPOSITE SIDE OF CAM BOX, bring back into working position 14 sts. 12x. (13 sts. 13x). [12 sts. 14x].

ON OPPOSITE SIDE OF CAM BOX, put into holding position 14 sts. 12x. (13 sts. 13x). [12 sts. 14x].

Bring all the needles back into working position before knitting the next row.

Knit to Row 74 (82) [90]**. Turn the Row Counter back to 0 and REPEAT from * to ** 9x more.

Change to waste yarn and knit 8 to 10 rows then remove the work from the machine by passing the slide across without yarn.

DK 312

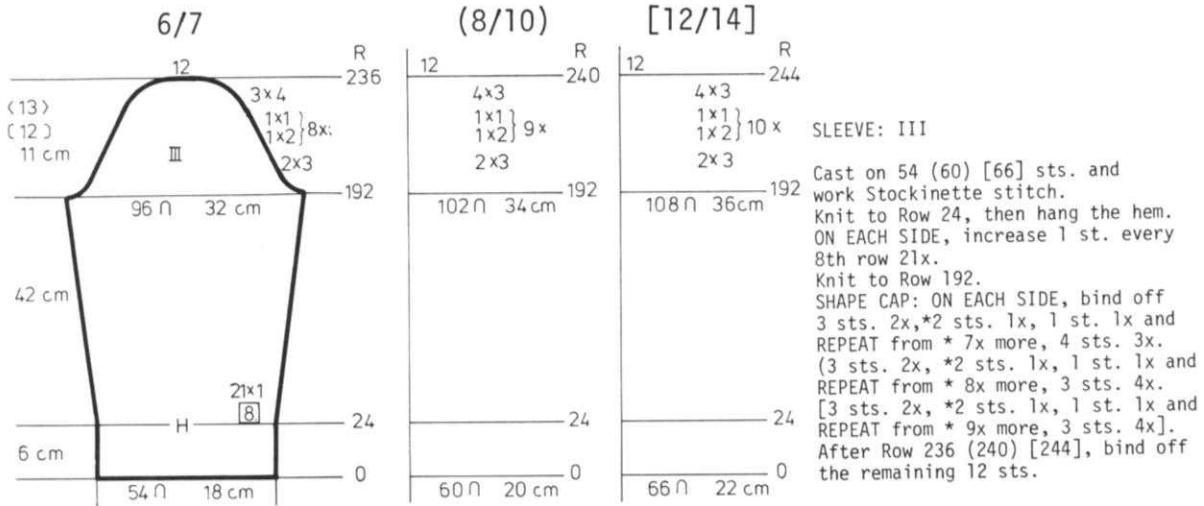

DK 313

WOMAN'S SLEEVELESS PULLOVER

SIZES: 14/16 (18/20) [22/24]
YARN: Nicole
GRAMS:
color 1 250 300 350
color 2 50 50 50
TENSION: 5 to 7
GAUGE: 15 sts. 23 rows = 5 cm (2")

Stockinette stitch with color stripes as shown on the Chart. Knitted sideways on the machine. Bands are K1, P1 Ribbing. The Purl side is the right side.

FINISHING: See General Instructions.

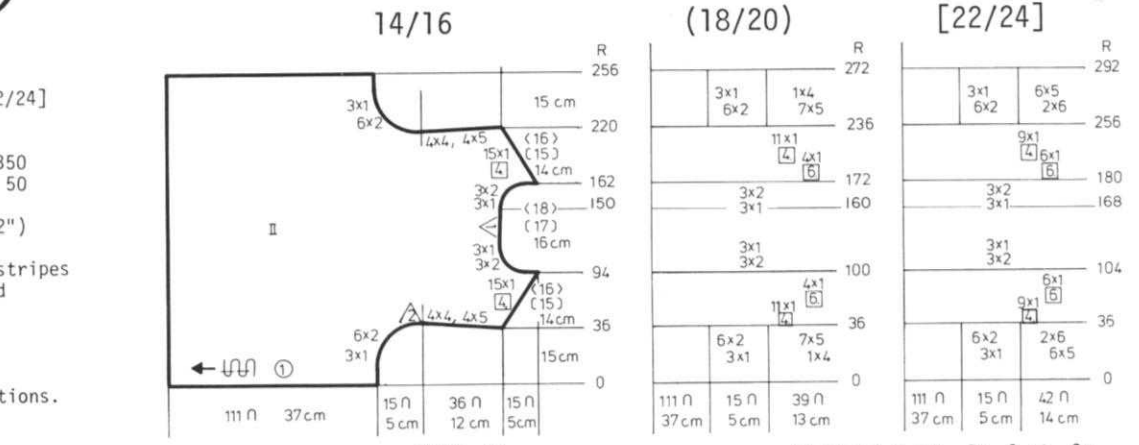

BACK: II

To the LEFT of machine, cast on 111 sts. with color 1. Work Stockinette stitch. ON THE RIGHT, on every 2nd row, cast on 1 st. 3x, 2 sts. 6x, 4 sts. 4x, 5 sts. 4x. (1 st. 3x, 2 sts. 6x, 4 sts. 1x, 5 sts. 7x). [1 st. 3x, 2 sts. 6x, 5 sts. 6x, 6 sts. 2x]. After Row 36, SHAPE SHOULDER: ON EVERY 4th ROW, cast on 1 st. 15x. (1 st. 11x, then every 6th row 1 st. 4x). [1 st. 9x, then every 6th row 1 st. 6x]. After Row 94 (100) [104], SHAPE NECK: For all sizes,

bind off 2 sts. 3x, 1 st. 3x. Knit to Row 150 (160) [168] then cast on 1 st. 3x, 2 sts. 3x. After Row 162 (172) [180], SHAPE SHOULDER: On every 4th row bind off 1 st. 15x. (every 6th row, 1 st. 4x, every 4th row 1 st. 11x). [every 6th row 1 st. 6x, every 4th row 1 st. 9x]. After Row 220 (236) [256], SHAPE ARMHOLE: Bind off 5 sts. 4x, 4 sts. 4x, 2 sts. 6x, 1 st. 3x. (5 sts. 7x, 4 sts. 1x, 2 sts. 6x, 1 st. 3x). [6 sts. 2x, 5 sts. 6x, 2 sts. 6x, 1 st. 3x]. After Row 256 (272) [292], bind off the remaining sts.

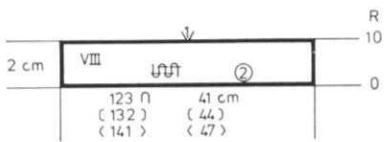

NECKBAND: VIII

Cast on 123 (132) [141] sts. with color 2 and work 10 rows K1, P1 Ribbing then bind off the crochet method for Ribbing.

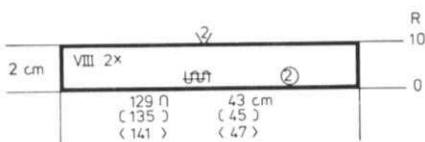

ARMBANDS: VIII Make 2.

Cast on 129 (135) [141] sts. with color 2 and work 10 rows K1, P1 Ribbing then bind off the crochet method for Ribbing.

14/16

(18/20)

[22/24]

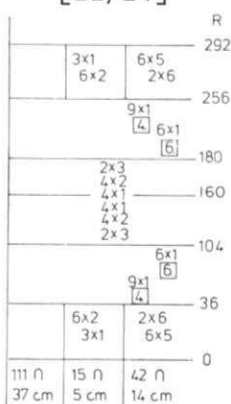
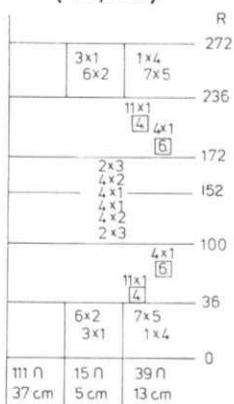
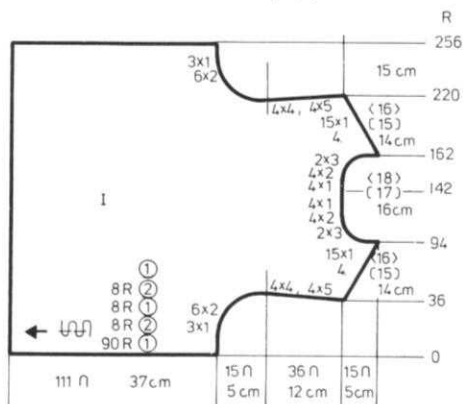

NECK:

On every 2nd row, for all sizes, bind off 3 sts. 2x, 2 sts. 4x. 1 st. 4x. Knit to Row 142 (152) [160], then cast on 1 st. 4x, 2 sts. 4x, 3 sts. 2x. After Row 162 (172) [180], SHAPE SHOULDER:

On every 4th row bind off 1 st. 15x.

(every 6th row 1 st. 4x, every 4th row 1 st. 11x). [every 6th row 1 st. 6x, every 4th row 1 st. 9x].

After Row 220 (236) [256], SHAPE ARMHOLE: On every 2nd row, bind off 5 sts. 4x, 4 sts. 4x, 2 sts. 6x, 1 st. 3x. (5 sts. 7x, 4 sts. 1x, 2 sts. 6x, 1 st. 3x). [6 sts. 2x, 5 sts. 6x, 2 sts. 6x, 1 st. 3x]. After Row 256 (272) [292], bind off the remaining sts.

FRONT: I

1 st. 3x, 2 sts. 6x, 4 sts. 4x, 5 sts. 4x.

(1 st. 3x, 2 sts. 6x, 4 sts. 1x, 5 sts. 7x).

[1 st. 3x, 2 sts. 6x, 5 sts. 6x, 6 sts. 2x].

After Row 36, SHAPE SHOULDER: On every 4th row, cast on 1 st. 15x.

(1 st. 11x, then every 6th row, 1 st. 4x).

[1 st. 9x then every 6th row 1 st. 6x].

After Row 94 (100) [104], SHAPE

To the LEFT of machine, cast on 111 sts. with color 1 and work Stockinette stitch with color stripes as shown on the Chart. ON THE RIGHT, on every 2nd row, cast on

HP 314

MAN'S VEST

SIZES: 34/36 (38/40) [42]
YARN: Crocus
GRAMS: 300 350 400
TENSION: 6 to 8
GAUGE: 16 sts. 22 rows = 5 cm (2")

Stockinette stitch with Cable Design and every 6th st. on the Ribber. Follow the Line Drawing. Bands are K1, P1 Ribbing.

FINISHING: See General Instructions.

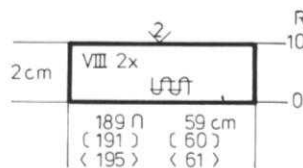

ARBANDS: VIII Make 2.

Cast on 189 (191) [195] sts. and work 10 rows K1, P1 Ribbing then bind off the crochet method for Ribbing.



BACK: II

Cast on 151 (163) [177] sts. and work 20 rows K1, P1 Ribbing. Continue in Pattern. Knit to Row 160.

SHAPE ARMHOLE: ON EACH SIDE, bind off 4 sts. 2x, 3 sts. 2x, 2 sts. 4x, 1 st. 4x. (4 sts. 3x, 3 sts. 2x, 2 sts. 3x, 1 st. 5x). [4 sts. 3x, 3 sts. 3x, 2 sts. 3x, 1 st. 5x].

Knit to Row 266 (270) [274]. Bind off the center 31 sts., put the needles on the left into holding position and complete the right half first.

*SHAPE SHOULDER AND NECK AT THE SAME TIME.

FOR SHOULDER, bind off

3 sts. 1x, 4 sts. 4x. (4 sts. 3x, 5 sts. 2x).

[5 sts. 4x, 6 sts. 1x].

FOR NECK, on all sizes, bind off

5 sts. 3x.

Bring the needles on the left into working position, knit 1 row to the left side, turn the Row Counter back to 266 (270) [274] and complete the left half. Follow the instructions from *.



Continued

34/36

(38/40)

[42]

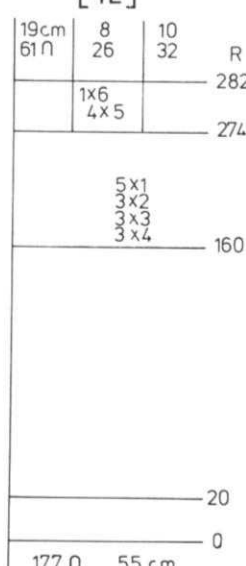
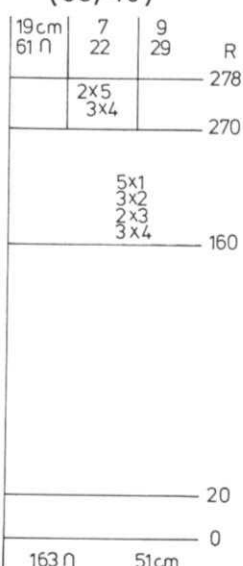
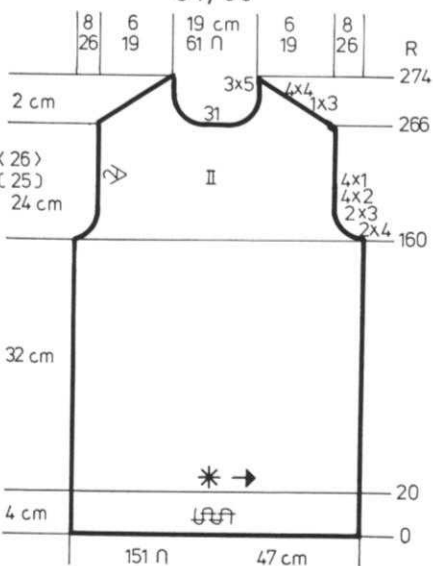

HP 314

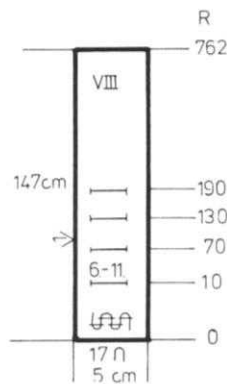
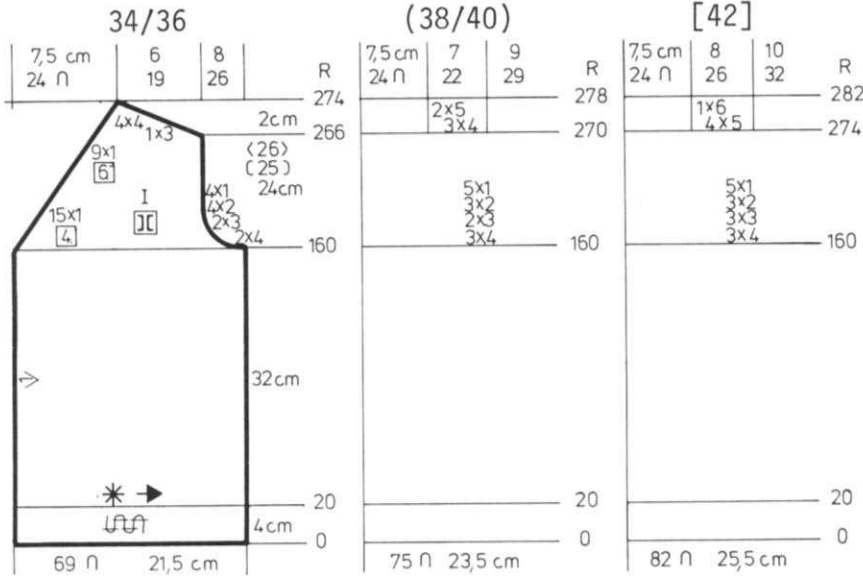

FRONT & NECKBAND: VIII

Cast on 17 sts. and work K1, P1 Ribbing.
Make **BUTTONHOLES** over needles 6 to 11 after the rows shown on the Chart then knit to Row 762 and bind off the crochet method for Ribbing.

FRONT: I Make 1, reverse 1.

Cast on 69 (75) [82] sts. and work 20 rows K1, P1 Ribbing. Continue in Pattern. Knit to Row 160. **SHAPE ARMHOLE AND NECK AT THE SAME TIME.** Make the bind-offs for armhole the same as the back and **ON NECK SIDE**, for all sizes, decrease 1 st. every 4th row 15x, every 6th row 9x and **SHAPE SHOULDER** same as the back after Row 266 (270) [274].

HP 315



MAN'S PULLOVER

SIZES: 34/36 (38) [40/42]
YARN: Fortissima
GRAMS: 350 400 450
TENSION: 5 to 7
GAUGE: 15 sts. 22 rows = 5 cm (2")



A Rib Pattern worn on the Purl side. Every 8th stitch on the Ribber. Bands are K1, P1 Ribbing.

FINISHING: See General Instructions.

BACK & FRONT: I/II

Cast on 138 (150) [162] sts. with every 8th stitch on the Ribber. Knit to Row 202. **SHAPE ARMHOLE: ON EACH SIDE**, bind off 3 sts. 2x, 2 sts. 2x, 1 st. 5x. (3 sts. 2x, 2 sts. 4x, 1 st. 4x). [3 sts. 3x, 2 sts. 3x, 1 st. 6x]. Knit to Row 294 (298) [302]. Bind off the center 18 sts., put the needles on the left into holding position and complete the right half first. ***SHAPE SHOULDER AND NECK AT THE SAME TIME.** **FOR SHOULDER**, bind off 3 sts. 2x, 4 sts. 6x. (4 sts. 7x, 5 sts. 1x). [4 sts. 4x, 5 sts. 4x]. **FOR NECK**, on all sizes, bind off 3 sts. 5x. Bring the needles on the left into working position, knit 1 row to the left side, turn the Row Counter back to 294 (298) [302] and complete the left half. Follow the instructions from *. Work 2nd section the same.

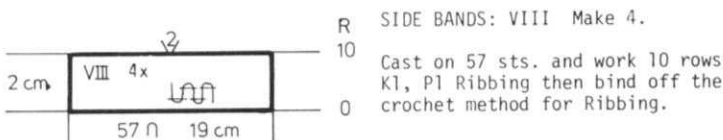
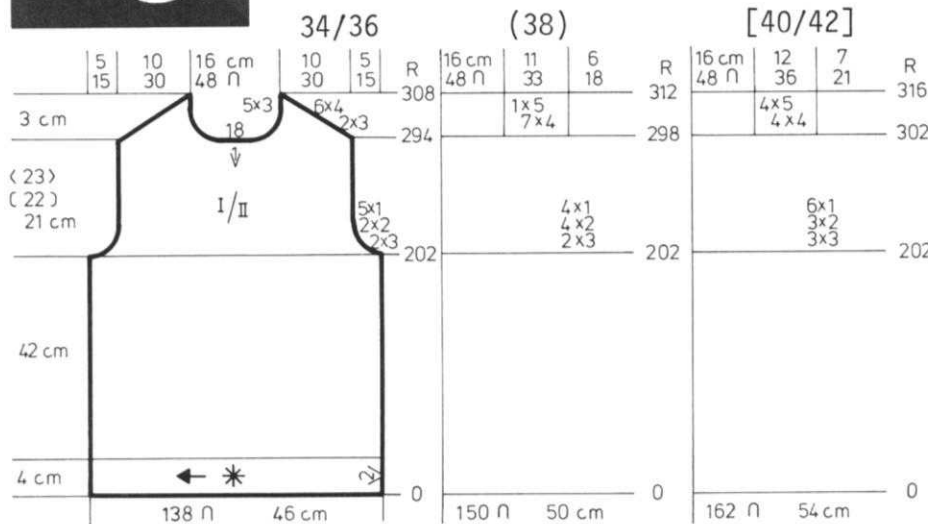

SIDE BANDS: VIII Make 4.

Cast on 57 sts. and work 10 rows K1, P1 Ribbing then bind off the crochet method for Ribbing.

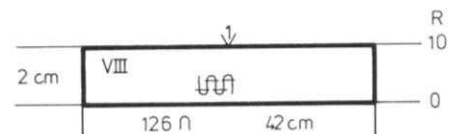

NECKBAND: VIII

Cast on 126 sts. and work 10 rows K1, P1 Ribbing then bind off the crochet method for Ribbing.

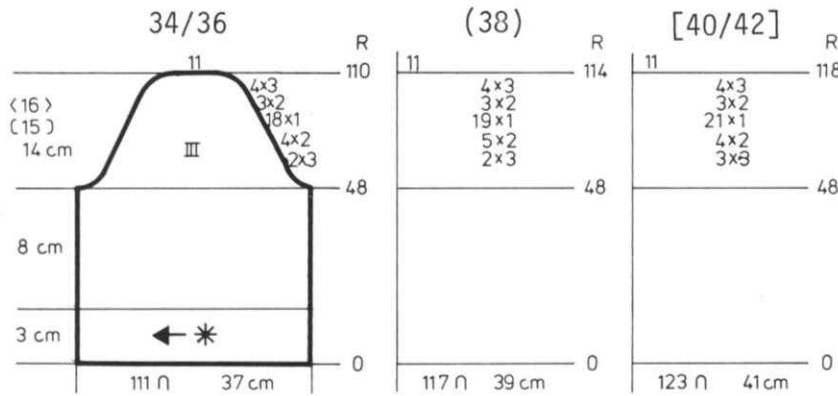

SLEEVES: III
 Cast on 111 (117) [123] sts. with every 8th st. on the Ribber. Knit to Row 48.
 SHAPE CAP: ON EACH SIDE, bind off 3 sts. 2x, 2 sts. 4x, 1 st. 18x, 2 sts. 3x, 3 sts. 4x. (3 sts. 2x, 2 sts. 5x, 1 st. 19x, 2 sts. 3x, 3 sts. 4x). [3 sts. 3x, 2 sts. 4x, 1 st. 21x, 2 sts. 3x, 3 sts. 4x]. After Row 110 (114) [118], bind off the remaining 11 sts.

KK 316

GIRL'S PLEATED SKIRT

SIZES: 6/7 (8/9) [10/11]
 YARN: Allegro
 GRAMS: 150 200 250
 TENSION: 9 or 10
 GAUGE: 13 sts. 18 rows = 5 cm (2")

Stockinette stitch with a Rib stitch. Lower edge, K1, P1 Ribbing. Waistband: Stockinette stitch.

FINISHING: Sew side seams. With knit side facing you, slip stitch crochet up the 8th stitch to make the fold that will meet the purl stitch. This stitch will be to the LEFT of the purl stitch on the right side of center and on the RIGHT to the left side of center. Baste pleats in place, then sew on waistband with 1 edge to the inside and 1 to the outside of waistline. Run elastic through casing made at waist. Work 1 row single crochet around lower edge.

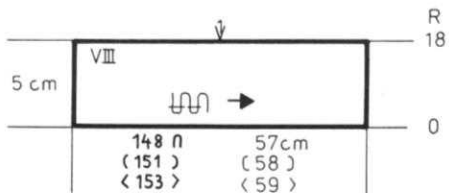
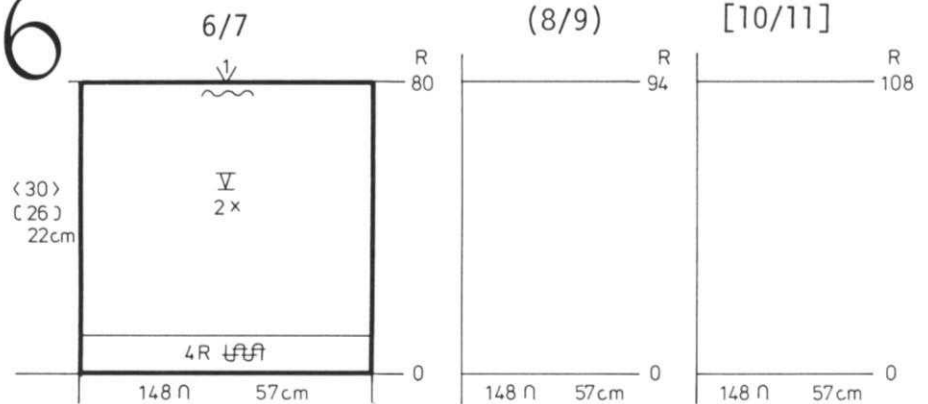

WAISTBAND: VIII
 Cast on 148 (151) [153] sts. and work 18 rows Stockinette stitch then bind off.

FRONT & BACK: IV/V
 Cast on 148 sts. and work 4 rows K1, P1 Ribbing. Counting from the center, leave EACH 26th st. ON EACH SIDE on the Ribber and transfer the remaining rib sts. to the main machine. Knit to Row 80 (94) [108], then bind off. Make 2nd section the same.

converta tape

For simple and speedy charting of custom knits.
 List Price \$10.95

(California residents add Sales Tax)
 Shipping charges: \$.65

Order direct from KNITKING

— 1128 Crenshaw Blvd., Los Angeles, California 90019

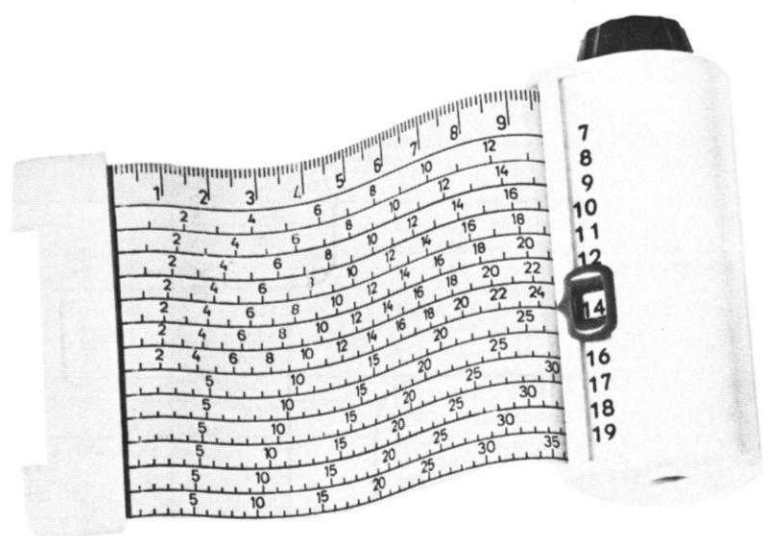

KK 317

GIRL'S PULLOVER

SIZES: 6/7 (8/9) [10/11]
 YARN: Allegro
 GRAMS:
 color 1 100 100 150
 color 2 100 100 100
 TENSION: 9 or 10
 GAUGE: 13 sts. 18 rows = 5 cm (2")

Stockinette stitch with REPEATED color stripes as shown on the Chart. Bands are K1, P1 Ribbing.

FINISHING: See General Instructions.

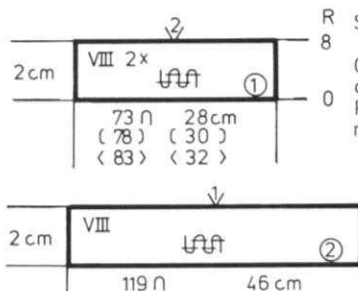

R SLEEVE BANDS: VIII Make 2.

Cast on 73 (78) [83] sts. with color 1 and work 8 rows K1, P1 Ribbing then bind off the crochet method for Ribbing.

R NECKBAND: VIII

Cast on 119 sts. with color 2 and work 8 rows K1, P1 Ribbing then bind off the crochet method for Ribbing.

BACK & FRONT: I/II

Cast on 78 (84) [88] sts. with color 1 and work 18 rows K1, P1 Ribbing.

Change to Stockinette stitch with REPEATED color stripes as shown on the Chart.

Knit to Row 76 (82) [90].
 SHAPE SLEEVE: ON EACH SIDE, cast on 1 st. 5x, 5 (5) [6] sts. 1x. Knit to Row 132 (142) [154]. Bind off the center 28 sts., put the needles on the left into holding position and complete the right half first.

*SHAPE SHOULDER AND NECK AT THE SAME TIME.

FOR SHOULDER, bind off 4 sts. 5x.

(4 sts. 2x, 5 sts. 3x).
 [5 sts. 4x, 6 sts. 1x].

FOR NECK, on all sizes, bind off 5 sts. 3x.

Bring the needles on the left into working position, knit 1 row to the left side, turn the Row Counter back to 132 (142) [154] and complete the left half.

Follow the instructions from *.
 Make 2nd section the same.

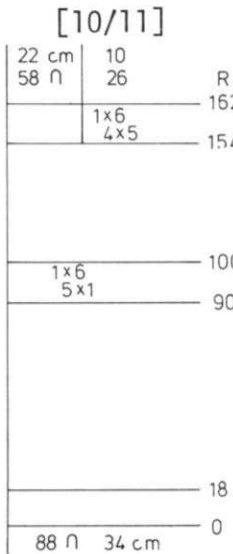
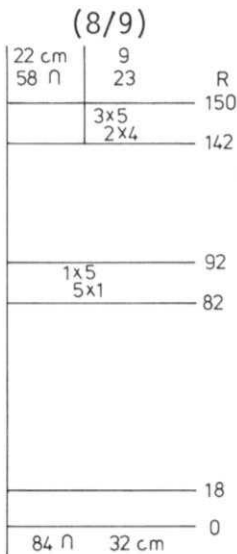
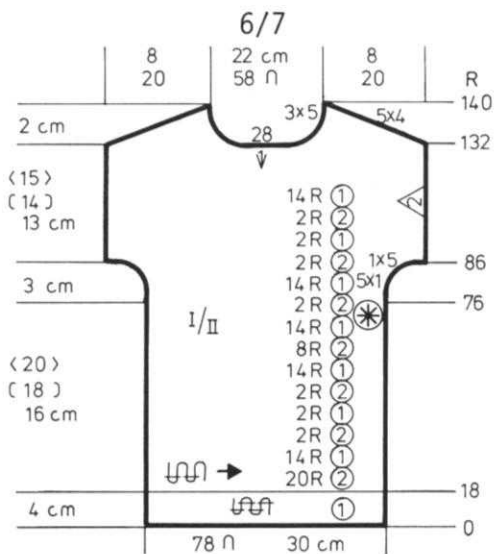

KK 318

TEEN GIRL'S CARDIGAN

SIZES: 9/10 (11/12) [13/14]
 YARN: Allegro
 GRAMS: 350 350 400
 TENSION: 5 to 7
 GAUGE: 14 sts. 28 rows = 5 cm (2")

Knitted sideways on the machine in a Holding Position Design that follows the Line Drawing. Worn on the purl side. KNITTING machine owners, use Wheel No. 2. Bands are K1, P1 Ribbing.

FINISHING: See General Instructions. Leave an opening at side seams at waistline for belt. Make Belt by knitting a cord over 7 needles (set your machine for knitting a cord). Pull cord down to close the stitches. Make long enough to go around waist and tie. See Picture.

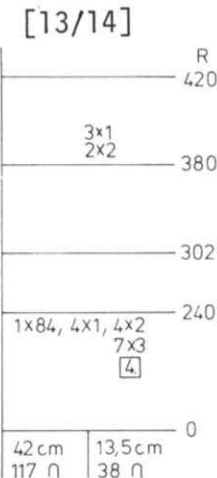
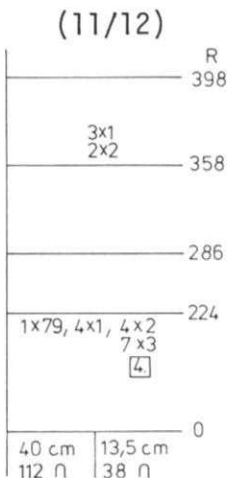
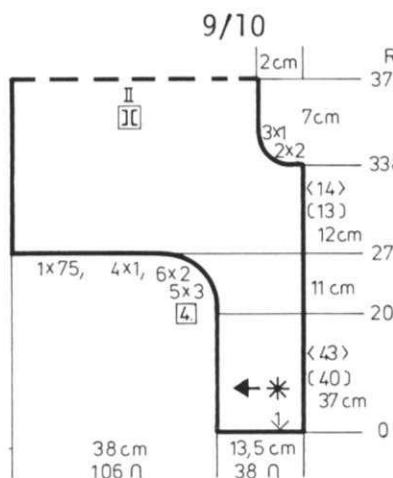
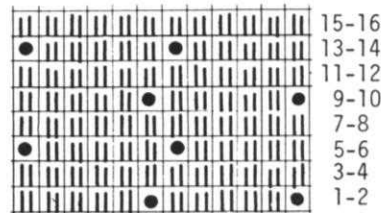

BACK: II

To the extreme right of machine, cast on 38 sts.

Work in Holding Position Design.

Knit to Row 208 (224) [240].

ON THE LEFT side, with a separate yarn, ON EVERY 4th ROW, cast on 3 sts. 5x, 2 sts. 6x, 1 st. 4x,

75 sts. 1x.

(3 sts. 7x, 2 sts. 4x, 1 st. 4x,

79 sts. 1x).

[3 sts. 7x, 2 sts. 4x, 1 st. 4x,

84 sts. 1x].

Knit to Row 338 (358) [380].

SHAPE NECK: FOR ALL SIZES, bind off 2 sts. 2x, 1 st. 3x.

Knit to Row 378 (398) [420].

This now the center of garment and you must work BACKWARDS.

Begin by knitting 30 rows,

then cast on for all sizes,

1 st. 3x, 2 sts. 2x, etc.,

binding off for the side and

underarm shaping instead of

casting on.

FRONT: I Make 1, reverse 1.

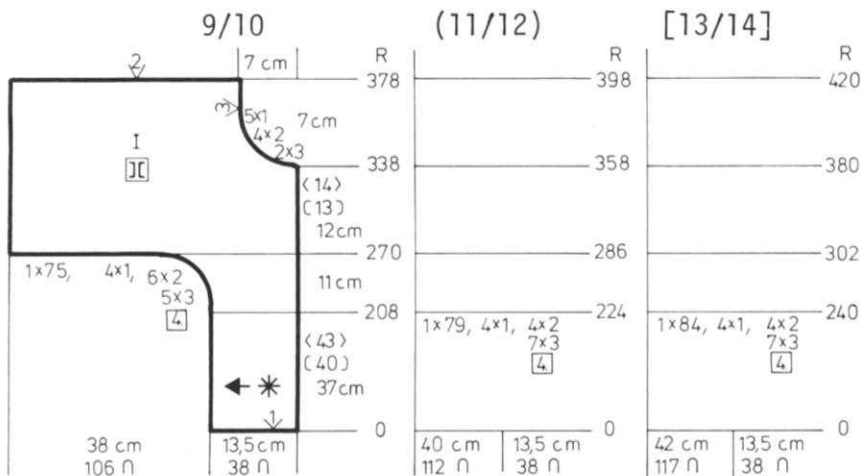

To the extreme right of machine (left for 2nd section) cast on 38 sts. Work in Holding Position Design. Knit to Row 208 (224) [240]. ON THE LEFT (right for 2nd section) side, with a separate yarn, ON EVERY 4th ROW, cast on 3 sts. 5x, 2 sts. 6x, 1 st. 4x, 75 sts. 1x. (3 sts. 7x, 2 sts. 4x, 1 st. 4x, 79 sts. 1x). [3 sts. 7x, 2 sts. 4x, 1 st. 4x, 84 sts. 1x]. Knit to Row 338 (358) [380]. SHAPE NECK: For all sizes, bind off 3 sts. 2x, 2 sts. 4x, 1 st. 5x. Knit to Row 378 (398) [420]. Bind off. Work the 2nd section with reverse shaping, casting on to the extreme LEFT of machine with Cam Box on the LEFT at Row 0 but remember to work the holding position design from the RIGHT.



Cast on 121 sts. and work 20 rows K1, P1 Ribbing then bind off the crochet method for Ribbing.

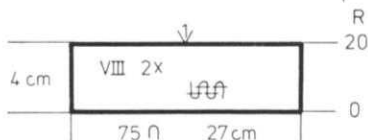

CUFFS: VIII Make 2.

Cast on 75 sts. and work 20 rows K1, P1 Ribbing then bind off the crochet method for Ribbing.

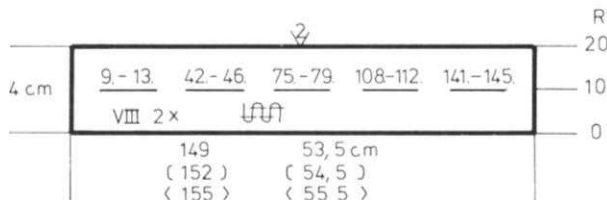

BUTTON & BUTTONHOLE BAND: VIII

Cast on 149 (152) [155] sts. and work K1, P1 Ribbing. After Row 10, make BUTTONHOLES over the needles as shown on the Chart. Knit to Row 20, then bind off the crochet method for Ribbing. Make 2nd band but omit the Buttonholes.

KK 319

BOY'S PANTS & PULLOVER



SIZES: 3/4 (5/6) [7/8]
YARN: Allegro
GRAMS:
color 1 200 200 250
color 2 100 100 150
TENSION: 5 to 7
GAUGE: 15 sts. 20 rows = 5 cm (2")

Stockinette stitch with REPEATED color stripes as shown on the Chart. Bands are K1, P1 Ribbing.

FINISHING: See General Instructions.

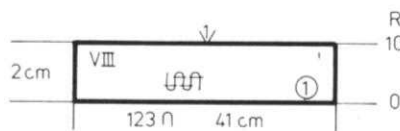

NECKBAND: VIII

Cast on 123 sts. with color 1 and work 10 rows K1, P1 Ribbing then bind off the crochet method for Ribbing.

PULLOVER FRONT & BACK: I/II

Cast on 90 (96) [102] sts. with color 1 and work 20 rows K1, P1 Ribbing. Change to Stockinette stitch with color stripes as shown on the Chart. Knit to Row 72 (76) [80]. SHAPE SLEEVES: ON EACH SIDE cast on 1 st. 3x, 2 sts. 3x, 3 sts. 2x, 24 sts. 1x. Knit to Row 136 (140) [144]. Bind off the center 24 sts., put the needles on the left into holding position and complete the right half first. *ON NECK SIDE, for all sizes, bind off 5 sts. 3x. After Row 144 (148) [152], bind off the remaining 57 (60) [63] sts. Bring the needles on the left into working position, knit 1 row to the left side, turn the Row Counter back to 136 (140) [144] and complete the left half. Follow the instructions from *. Make the 2nd section the same.

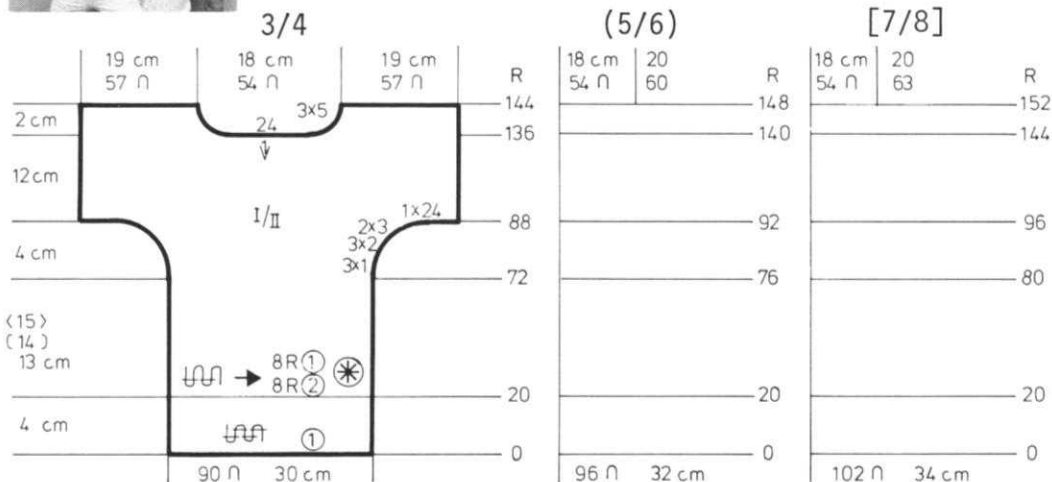

Continued



KK 319

PANTS BACK: XII Make 1, reverse 1.

Cast on 57 (61) [66] sts. with color 1 and work Stockinette stitch. Knit to Row 24 (If you are sure of length, you can hang the hem at Row 16).

SHAPE CENTER BACK: ON CAM BOX side bind off
3 sts. 3x, 2 sts. 1x, 1 st. 2x, then every 12th row 1 st. 3x, every 10th row 1 st. 2x.
(3 sts. 2x, 2 sts. 2x, 1 st. 2x, then every 12th row 1 st. 6x).
[3 sts. 2x, 2 sts. 2x, 1 st. 2x, then every 14th row 1 st. 3x, every 12th row 1 st. 3x].
After Row 84 (88) [92], work Short Rows.

ON OPPOSITE SIDE OF CAM BOX, put into holding position, 8 sts. 4x.
After Row 92 (96) [100], bring all the needles into working position and knit to Row 112 (116) [120].
Bind off.
Work the 2nd section with reverse shaping, casting on from RIGHT to LEFT. Cam Box will be on the LEFT side at Row 0.

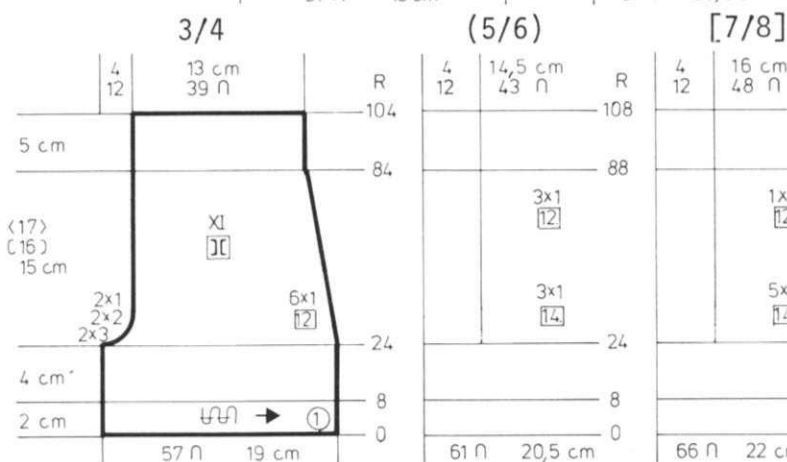
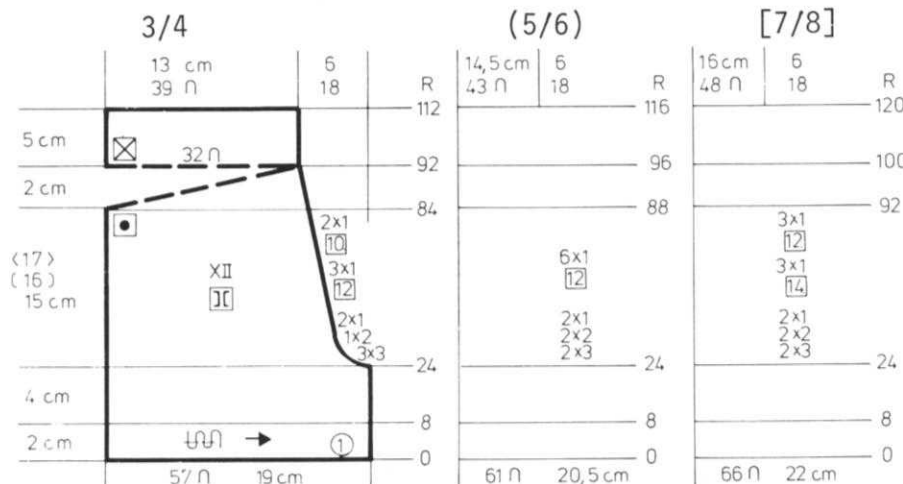

PANTS FRONT: XI Make 1, reverse 1.

Cast on 57 (61) [66] sts. with color 1 and work Stockinette stitch. Knit to Row 16 (hang hem if you did on back section). Knit to Row 24. SHAPE SIDE EDGE AND CENTER FRONT AT THE SAME TIME.
FOR SIDE EDGE, decrease 1 st. every 12th row 6x.
(every 14th row 3x, every 12th row 3x).
[every 14th row 5x, every 12th row 1x].
FOR CENTER FRONT, on all sizes, bind off 3 sts. 2x, 2 sts. 2x, 1 st. 2x. Knit to Row 104 (108) [112], then bind off the remaining sts.
Work the 2nd front section with reverse shaping, casting on from RIGHT to LEFT. Cam Box will be on the LEFT side at Row 0.

KK 320

GIRL'S RAGLAN PULLOVER

SIZES: 4/5 (6/7) [8/9]
YARN: Amore
GRAMS: color 1 150 200 250
color 2 50 50 50
TENSION: 6 to 8
GAUGE: 13 sts. 22 rows = 5 cm (2")

Stockinette stitch worn on the Purl side. The sleeves have REPEATED color stripes as shown on the Chart. Bands are K1, P1 Ribbing.

FINISHING: See General Instructions.

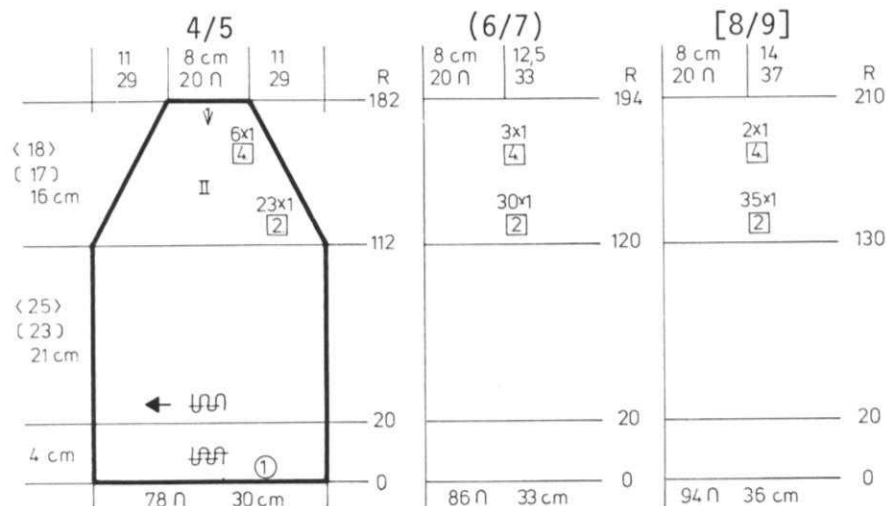

BACK: II

Cast on 78 (86) [94] sts. with color 1 and work 20 rows K1, P1 Ribbing.
Change to Stockinette stitch. Knit to Row 112 (120) [130].
SHAPE RAGLAN: ON EACH SIDE, decrease 1 st. every 2nd row 23x (30x) [35x], every 4th row 6x (3x) [2x].
After Row 182 (194) [210], bind off the remaining 20 sts.

NECKBAND: VIII

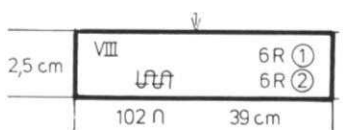

Cast on 102 sts. with color 2 and work K1, P1 Ribbing with color stripes as shown on the Chart. After Row 12, bind off the crochet method for Ribbing.

SLEEVE: III Make 1 reverse 1.

Cast on 63 (64) [67] sts. with color 2 and work 10 rows K1, P1 Ribbing. Change to Stockinette stitch with REPEATED color stripes as shown on the Chart. Knit to Row 28.

SHAPE RAGLAN: ON EACH SIDE, decrease 1 st. every 2nd row 11x for all sizes, then on every 4th row, ON CAM BOX SIDE, decrease 1 st. 12x (13x) [14x] and ON OPPOSITE SIDE OF CAM BOX, decrease 1 st. 9x (9x) [11x]. After Row 86 (90) [94], work Short Rows. ON OPPOSITE SIDE OF CAM BOX, put into holding position for all sizes, 2 sts. 4x, 3 sts. 4x. After Row 100 (104) [108], bring all the needles back into working position and bind off loosely. Work the 2nd sleeve with reverse shaping, casting on from RIGHT to LEFT. Cam Box will be on the LEFT side at Row 0.

FRONT: I

Work the front the same as the back to Row 112 (120) [130]. SHAPE RAGLAN: ON EACH SIDE, decrease 1 st. every 2nd row 21x (27x) [33x], every 4th row 4x (2x) [0x] AND AT THE SAME TIME, after Row 156 (168) [182], SHAPE NECK: Bind off the center 8 sts., put the needles on the left into holding position and complete the right half first. *ON NECK SIDE, on every 2nd row, bind off for all sizes, 2 sts. 2x, 1 st. 3x. After Row 170 (182) [196], hang the remaining sts. together and bind off. Move the Cam Box to the left side, turn the Row Counter back to 156 (168) [182] and complete the left half. Follow the instructions from * and don't forget to finish the raglan shaping.

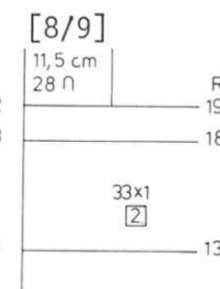
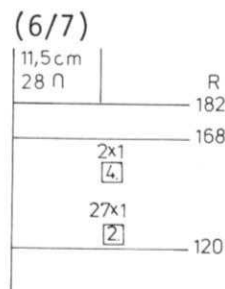
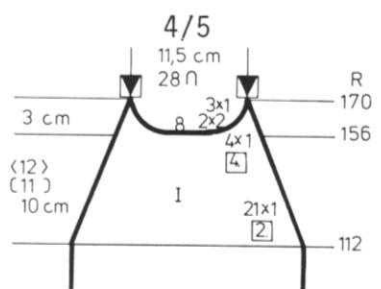
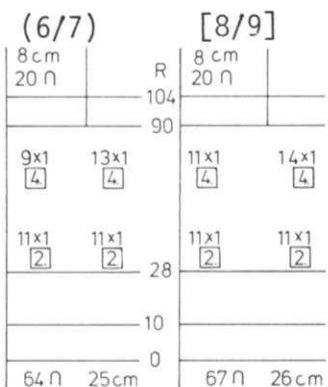
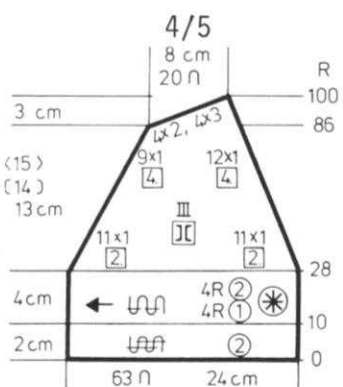

KK 321

CHILD'S PULLOVER

SIZES: 1/2 (3/4) [5/6]
 YARN: Allegro
 GRAMS: 100 150 200
 Small amounts of pink and blue for embroidered flowers.
 TENSION 5 to 7
 GAUGE: 15 sts. 20 rows = 5 cm (2").

FINISHING: See General Instructions. Work 2 rows single crochet around neck and back opening. Make loop on 1 side, sew button to other side of opening. Embroider small flowers in pink and blue on the front section. See picture.



Stockinette stitch worn on the purl side, Bands are K1, P1 Ribbing.

BACK: II

Cast on 78 (88) [96] sts. and work 58 rows K1, P1 Ribbing. Change to Stockinette stitch and knit to Row 68 (90) [102]. SHAPE ARMHOLE: ON EACH SIDE bind off 3 sts. 1x, 2 sts. 3x, 1 st. 3x. (3 sts. 2x, 2 sts. 2x, 1 st. 4x). [3 sts. 2x, 2 sts. 3x, 1 st. 3x]. After Row 84 (110) [126], divide in the center, put the needles on the left into holding position and complete the right half first. *Knit to Row 108 (134) [150]. SHAPE SHOULDER AND NECK AT THE SAME TIME. FOR SHOULDER, bind off 2 sts. 1x, 3 sts. 4x. (3 sts. 5x). [3 sts. 3x, 4 sts. 2x]. FOR NECK, bind off 4 sts. 1x, 3 sts. 3x. (6 sts. 1x, 3 sts. 3x). [4 sts. 4x]. Move the Cam Box to the left side, turn the Row Counter back to 84 (110) [126] and complete the left half. Follow the instructions from *.

Continued

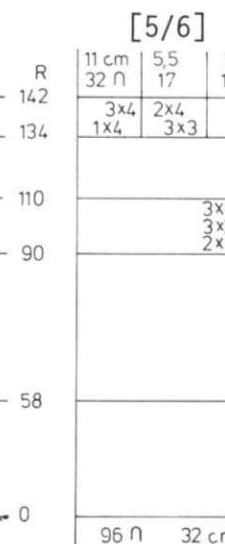
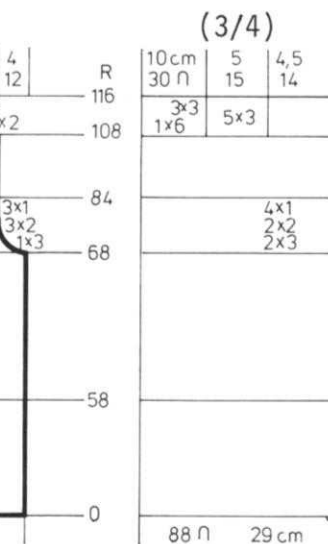
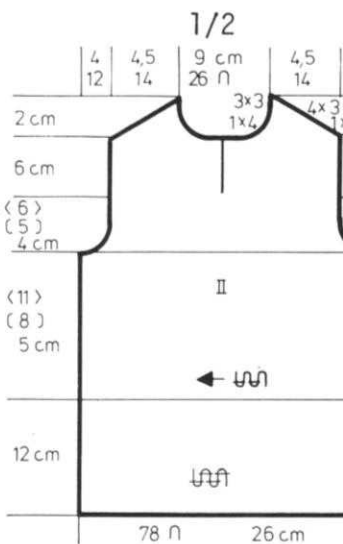

KK 321

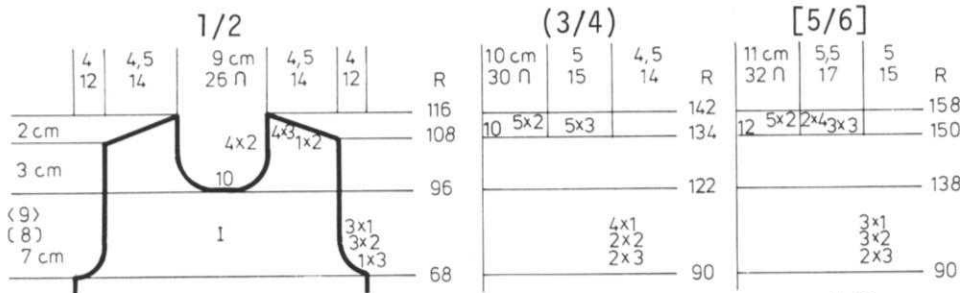

FRONT: I

Work the front the same as the back to Row 68 (90) [102].
SHAPE ARMHOLE same as the back then knit to Row 96 (122) [138].
Bind off the center 10 (10) [12] sts. put the needles on the left into holding position and complete the right half first.
*ON NECK SIDE, bind off 2 sts. 4x (5x) [5x] and SHAPE SHOULDER same as the back after Row 108 (134) [150].
Move the Cam Box to the left side, turn the Row Counter back to 96 (122) [138] and complete the left half. Follow the instructions from *.

SLEEVE: III

Cast on 44 (48) [50] sts. and work 10 rows K1, P1 Ribbing.
Change to Stockinette stitch.
ON EACH SIDE, increase 1 st. every 10th row 2x (4x) [6x], every 8th row 6x (4x) [2x].
Knit to Row 78 (82) [86].
SHAPE CAP: ON EACH SIDE, bind off 3 sts. 1x, 2 sts. 10x, 3 sts. 1x. (3 sts. 3x, *2 sts. 1x, 1 st. 2x and REPEAT from * 2x more, 3 sts. 2x). [3 sts. 2x, *1 st. 2x, 2 sts. 1x, and REPEAT from * 3x more, 3 sts. 2x].
After Row 102 (110) [118], bind off the remaining 8 (10) [10] sts.

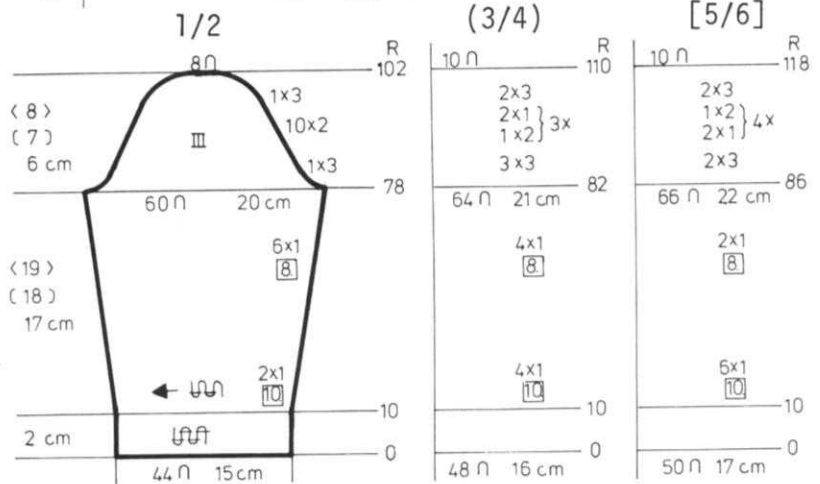

HP 322

MAN'S JACKET

SIZES: 38/40 (42) [44/46]
YARN: Euro Sport
GRAMS: 900 950 1000
TENSION: 10
GAUGE: 11 sts. 18 rows = 5 cm (2")



Stockinette stitch worn on the purll side. Pocket Band, K1, P1 Ribbing.

FINISHING: See General Instructions.
Sew pocket lining to back edge of opening then sew in place on the wrong side. Sew Ribbing to front side of opening on the right side. See picture.

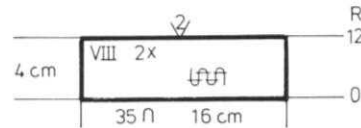

POCKET BAND: VIII Make 2.

Cast on 35 sts. and work 12 rows K1, P1 Ribbing then bind off the crochet method for Ribbing.

BACK: II

Cast on 113 (121) [131] sts. and work Stockinette stitch.
Knit to Row 148.
SHAPE ARMHOLE: ON EACH SIDE, bind off 3 sts. 1x, 2 sts. 2x, 1 st. 4x. (3 sts. 1x, 2 sts. 3x, 1 st. 4x). [3 sts. 2x, 2 sts. 3x, 1 st. 4x].
Knit to Row 216 (218) [222].
Bind off the center 15 sts., put the needles on the left into holding position and complete the right half first.
*SHAPE SHOULDER AND NECK AT THE SAME TIME.
FOR SHOULDER, bind off 4 sts. 6x, 5 sts. 1x. (4 sts. 4x, 5 sts. 3x). [4 sts. 2x, 5 sts. 5x].
FOR NECK, on all sizes, bind off 3 sts. 3x.
Move the Cam Box to the left side, turn the Row Counter back to 216 (218) [222] and complete the left half. Follow the instructions from *.

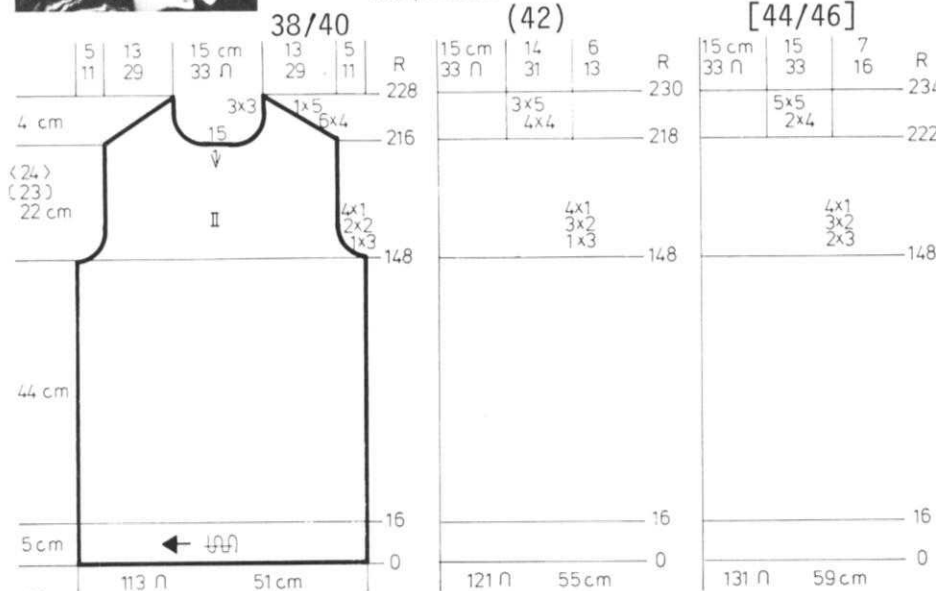

FRONT: I Make 1 reverse 1 and omit the buttonholes.

Cast on 38 (42) [47] sts. and work Stockinette stitch. Knit to Row 16, then with a separate yarn, cast on 31 sts. on the LEFT (right for 2nd section) side. Knit to Row 32.

Make **BUTTONHOLES** over needles 3 to 7 and 25 to 29 counting from the FRONT edge and AT THE SAME TIME, after making the buttonholes, leave 22 sts. in working position on the right side (left for 2nd section) and put all the needles on the left (right) into holding position. Knit to Row 80 over the 22 sts. left in work. Now, put these 22 sts. into holding position and bring the needles on the left (right) into working position, turn the Row Counter back to 32 and make **BUTTONHOLES** over the same needles as before after Row 64. Knit to Row 80. Break the yarn and bring all the needles into working position, attach yarn at the right edge and continue knitting over all the needles. Make **BUTTONHOLES** the same as before after Row 96 and 128 then knit to Row 148.

ON **ARMHOLE** SIDE, make the bind-offs the same as the back and on **FRONT** EDGE, increase 1 st. every 4th row 19x and don't forget to make another Buttonhole after Row 160. After Row 206 (208) [212], **SHAPE NECK**. Leave 43 (45) [47] needles in work and put all the rest of the needles on the left of these into holding position and complete the right half first. ON **NECK** SIDE for all sizes, bind off 3 sts. 2x, 2 sts. 2x, 1 st. 4x and **SHAPE SHOULDER** same as the back after Row 216 (218) [222]. Bring the remaining needles into working position. Cam Box is on the right (left for 2nd section) Bind off 14 sts. for center neck, knit 1 row, turn the Row Counter back to 206 (208) [212] and complete the left (right) side. ON **NECK** SIDE, bind off 3 sts. 2x, 2 sts. 2x, 1 st. 4x and after Row 224 (228) [232], bind off 3 sts. 2x. Make the right front section with reverse shaping casting on from **RIGHT** to **LEFT**. Cam Box will be on the **LEFT** side at Row 0 and omit the Buttonholes.

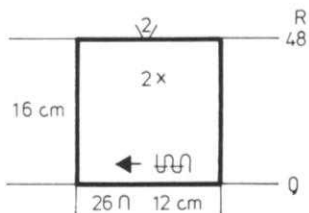

POCKET LINING: Make 2.

Cast on 26 sts. and work 48 rows Stockinette stitch then bind off.

COLLAR: VI

Cast on 88 sts. and work Stockinette stitch and Short Rows. ON **OPPOSITE** SIDE OF CAM BOX, put into holding position 28 sts. at Row 0 and after Row 1. ON **OPPOSITE** SIDE OF CAM BOX, bring back into working position 4 sts. 7x ON EACH SIDE. Knit to Row 54. ON **OPPOSITE** SIDE OF CAM BOX, put into holding position 4 sts. 6x ON EACH SIDE. After Row 66, ON **OPPOSITE** SIDE OF CAM BOX, bring all the needles back into working position before knitting the next 2 rows, then bind off.

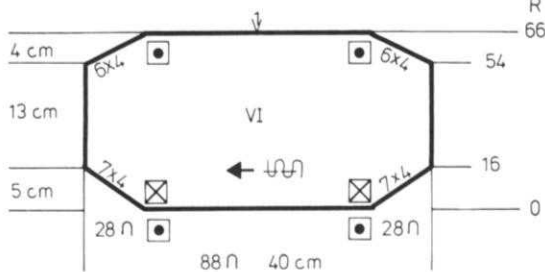

38/40

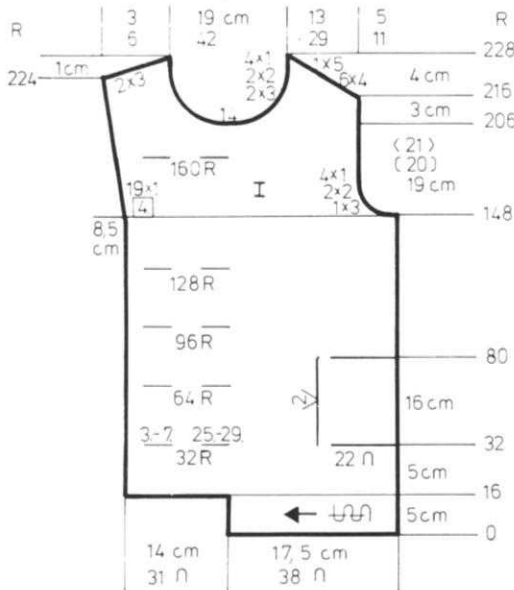

(42)

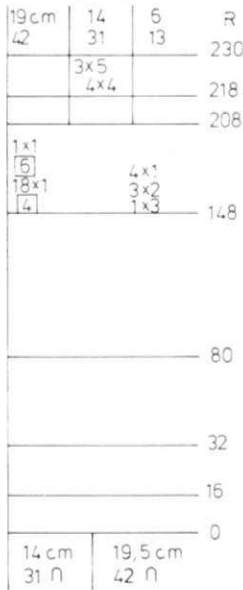

[44/46]

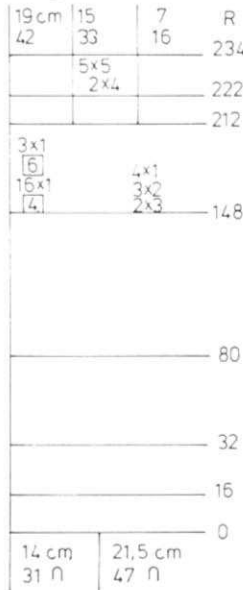

38/40

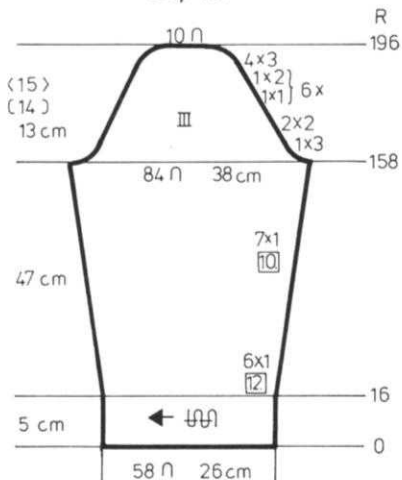

(42)

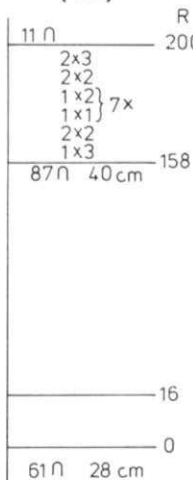

[44/46]

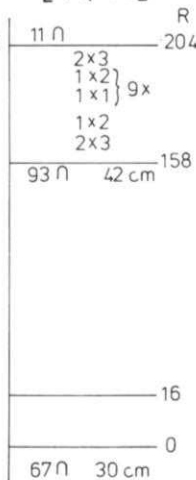

SLEEVE: IIII

Cast on 58 (61) [67] sts. and work Stockinette stitch. Knit to Row 16. ON EACH SIDE, increase 1 st. every 12th row 6x, every 10th row 7x. Knit to Row 158. **SHAPE CAP: ON EACH** SIDE, bind off 3 sts. 1x, 2 sts. 2x, *1 st. 1x, 2 sts. 1x, and REPEAT from * 5x more, 3 sts. 4x. (3 sts. 1x, 2 sts. 2x, *1 st. 1x, 2 sts. 1x, and REPEAT from * 6x more, 2 sts. 2x, 3 sts. 2x). [3 sts. 2x, 2 sts. 1x, *1 st. 1x, 2 sts. 1x, and REPEAT from * 8x more, 3 sts. 2x]. After Row 196 (200) [204] bind off the remaining 10 (11) [11] sts.

HP 323

MAN'S PULLOVER

SIZES: 34/36 (38/40) [42]

YARN: Crocus

GRAMS:

| | | | |
|---------|-----|-----|-----|
| color 1 | 350 | 400 | 400 |
| color 2 | 350 | 400 | 400 |
| color 3 | 50 | 50 | 50 |

TENSION: 6 to 8

GAUGE: 16 sts. 21 rows = 5 cm (2")

FINISHING: See General Instructions.

Sew 1 neck and collar band to the inside and 1 to the outside of opening and collar. See Picture. Embroider initial on front.

Stockinette stitch with color stripes as shown on the Chart. Bands are K1, P1 Ribbing.

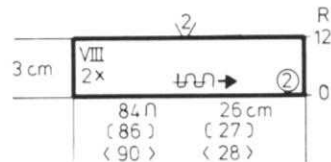

FRONT & COLLAR BAND: VIII
Make 2.

Cast on 84 (86) [90] sts. with color 2 and work 12 rows K1, P1 Ribbing then bind off the crochet method for Ribbing.

BACK: II

Cast on 136 (148) [160] sts. with color 1 and work 24 rows K1, P1 Ribbing.
Change to Stockinette stitch. ON EACH SIDE, increase 1 st. every 20th row 6x.
Knit to Row 188.
SHAPE ARMHOLE: ON EACH SIDE, bind off (watch the color stripes) 3 sts. 2x, 2 sts. 3x, 1 st. 4x. (3 sts. 3x, 2 sts. 3x, 1 st. 4x). [3 sts. 4x, 2 sts. 3x, 1 st. 4x]. Knit to Row 268 (272) [280]. Bind off the center 18 sts., put the needles on the left into holding position and complete the right half first.
*SHAPE SHOULDER AND NECK AT THE SAME TIME.
FOR SHOULDER, bind off 4 sts. 6x, 5 sts. 1x. (4 sts. 3x, 5 sts. 4x). [5 sts. 7x].
FOR NECK, on all sizes, bind off 4 sts. 5x.
Move the Cam Box to the left side, turn the Row Counter back to 268 (272) [280] and complete the left half. Follow the instructions from *.

FRONT: I

Work the front the same as the back to Row 188.
Bind off the center 10 sts., put the needles on the left into holding position and complete the right half first.
*SHAPE ARMHOLE same as the back and work the color stripes as shown on the Chart, then continue with color 2.
After Row 255 (259) [267], SHAPE NECK: ON NECK SIDE, bind off 3 sts. 4x, 2 sts. 4x, 1 st. 4x and SHAPE SHOULDER same as the back after Row 268 (272) [280].
Move the Cam Box to the left side, turn the Row Counter back to 188 and complete the left half. Follow the instructions from *.

SLEEVE: III

Cast on 72 (78) [84] sts. with color 2 and work 24 rows K1, P1 Ribbing. Change to Stockinette stitch. ON EACH SIDE, increase 1 st. every 8th row 20x, every 6th row 2x. Knit to Row 196.
SHAPE CAP: ON EACH SIDE, bind off 5 sts. 1x, 4 sts. 2x, 3 sts. 1x, 2 sts. 1x, 1 st. 18x (20x) [22x], 2 sts. 1x, 4 sts. 3x.
After Row 250 (254) [258], bind off the remaining 16 (18) [20] sts.

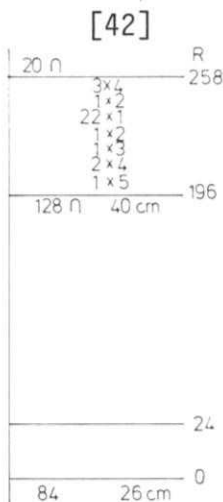
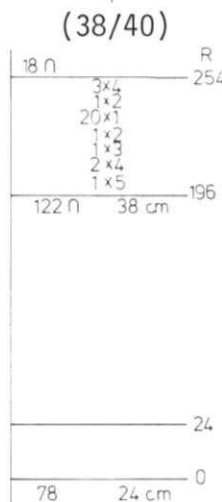
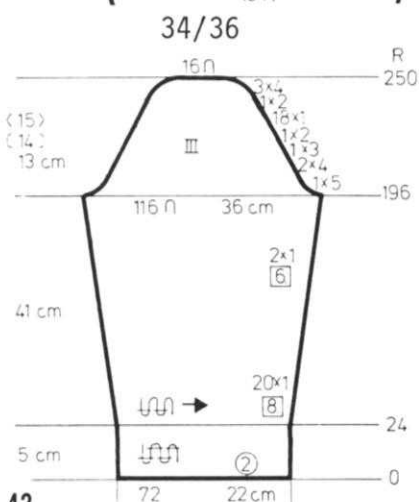
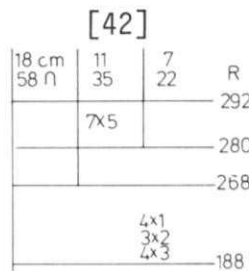
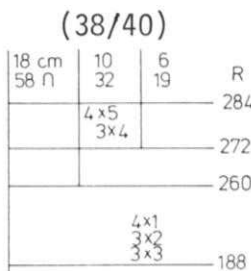
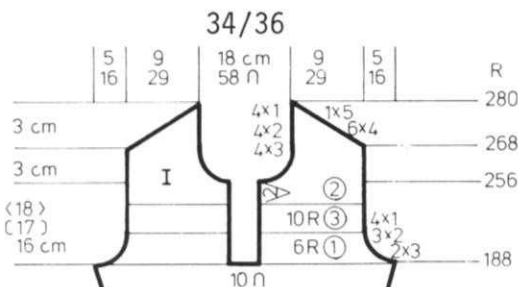
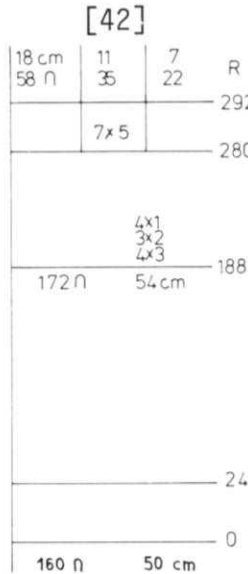
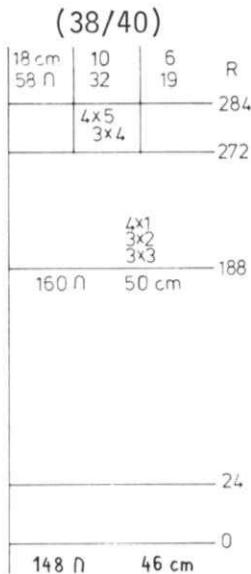
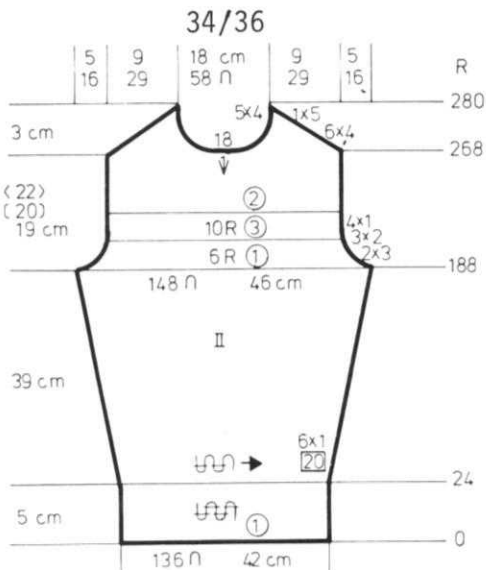

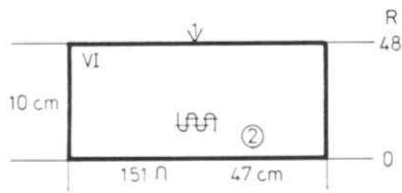

COLLAR: VI

Cast on 151 sts. with color 2 and work 48 rows K1, P1 Ribbing then bind off the crochet method for Ribbing.

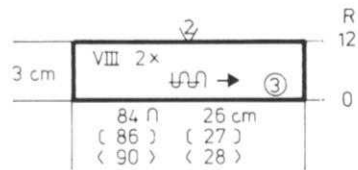

FRONT & COLLAR BAND: VIII
Make 2.

Cast on 84 (86) [90] sts. with color 3 and work 12 rows K1, P1 Ribbing then bind off the crochet method for Ribbing.

HP 324

MAN'S JACKET

SIZES: 34/36 (38) [40/42]
 YARN: Binia
 GRAMS:
 color 1 550 600 650
 color 2 200 200 200
 TENSION: 7 to 9
 GAUGE: 14 sts. 20 rows = 5 cm (2")

Stockinette stitch with bands in K1, P1 Ribbing using color 2.

FINISHING: See General Instructions. Work 1 row single crochet down front opening then sew in zipper. Sew on pockets. See picture.

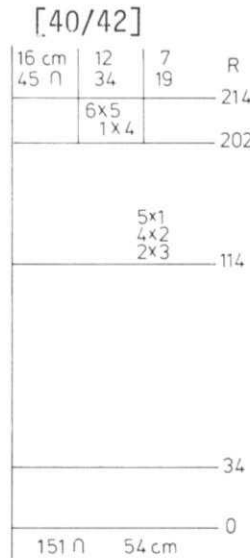
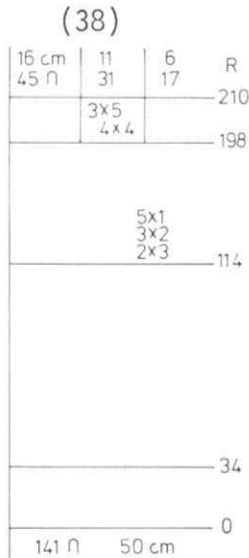
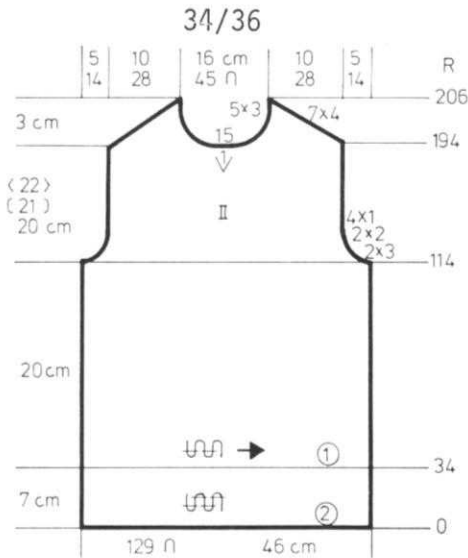

BACK: II

Cast on 129 (141) [151] sts. with color 2 and work 34 rows K1, P1 Ribbing. Change to color 1 and Stockinette stitch. Knit to Row 114. SHAPE ARMHOLE: ON EACH SIDE, bind off 3 sts. 2x, 2 sts. 2x, 1 st. 4x. (3 sts. 2x, 2 sts. 3x, 1 st. 5x). [3 sts. 2x, 2 sts. 4x, 1 st. 5x]. Knit to Row 194 (198) [202]. Bind off the center 15 sts., put the needles on the left into holding position and complete the right half first. *SHAPE SHOULDER AND NECK AT THE SAME TIME. FOR SHOULDER, bind off 4 sts. 7x. (4 sts. 4x, 5 sts. 3x.). [4 sts. 1x, 5 sts. 6x]. FOR NECK, on all sizes, bind off 3 sts. 5x. Move the Cam Box to the left side, turn the Row Counter back to 194 (198) [202] and complete the left half. Follow the instructions from *.

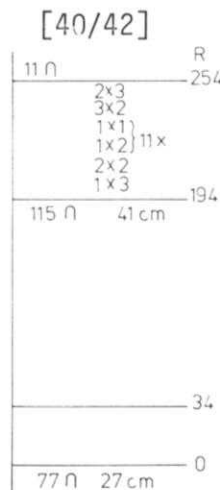
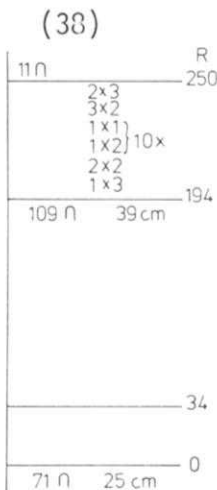
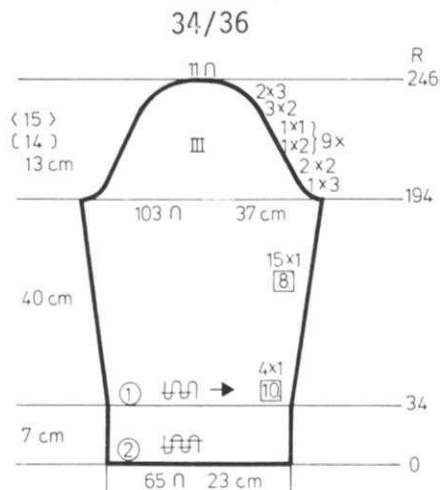

SLEEVE: III

Cast on 65 (71) [77] sts. with color 2 and work 34 rows K1, P1 Ribbing. Change to color 1 and Stockinette stitch. ON EACH SIDE, increase 1 st. every 10th row 4x, every 8th row 15x. Knit to Row 194. SHAPE CAP: ON EACH SIDE, bind off 3 sts. 1x, 2 sts. 2x, *2 sts. 1x, 1 st. 1x and REPEAT from * 8x (9x) [10x] more, 2 sts. 3x, 3 sts. 2x. After Row 246 (250) [254], bind off the remaining sts.

HP 324

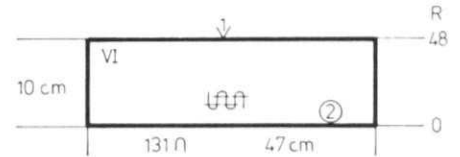

COLLAR: VI

Cast on 131 sts. with color 2 and work 48 rows K1, P1 Ribbing then bind off the crochet method for Ribbing.

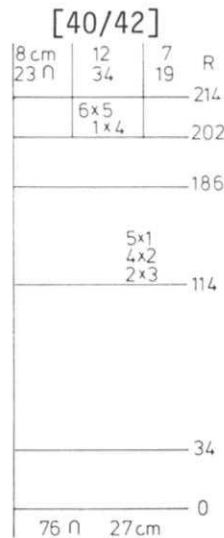
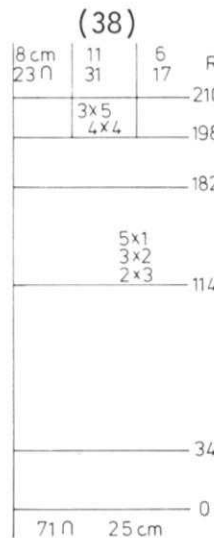
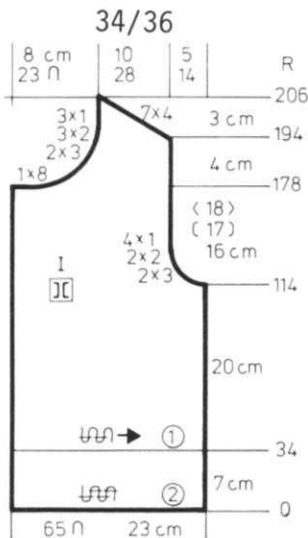

FRONT: I Make 1, reverse 1.

Cast on 65 (71) [76] sts. with color 2 and work 34 rows K1, P1 Ribbing. Change to color 1 and Stockinette stitch. Knit to Row 114. SHAPE ARMHOLE: ON ARM SIDE, make the bind-offs the same as the back then knit to Row 177 (181) [185]. SHAPE NECK: For all sizes, bind off 8 sts. 1x, 3 sts. 2x, 2 sts. 3x, 1 st. 3x and SHAPE SHOULDER same as the back after Row 194 (198) [202].

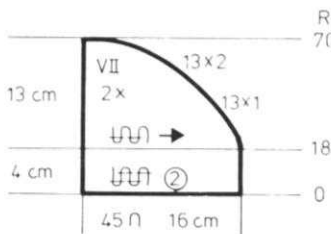

POCKET: Make 1, reverse 1.

Cast on 45 sts. with color 2 and work 18 rows K1, P1 Ribbing. Change to Stockinette stitch and ON CAM BOX SIDE, decrease 1 st. 13x, 2 sts. 13x. After Row 70, bind off the remaining sts.

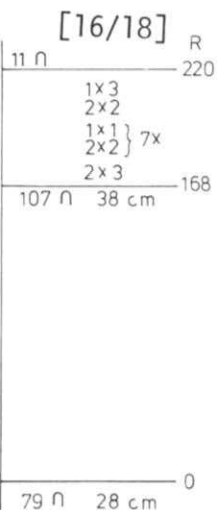
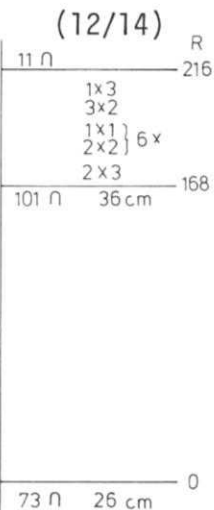
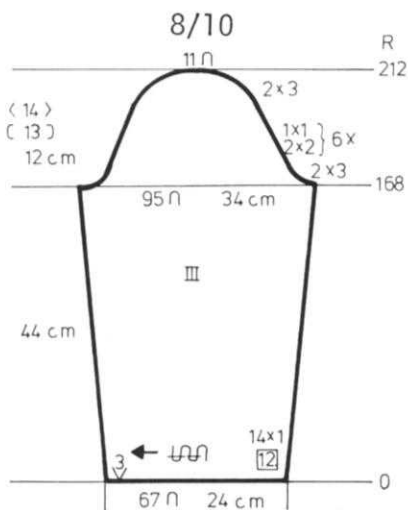

SLEEVES: III

Cast on 67 (73) [79] sts. and work Stockinette stitch. ON EACH SIDE, increase 1 st. every 12th row 14x. Knit to Row 168. SHAPE CAP: ON EACH SIDE, bind off 3 sts. 2x, *2 sts. 2x, 1 st. 1x, and REPEAT from * 5x more, 3 sts. 2x. (3 sts. 2x, *2 sts. 2x, 1 st. 1x and REPEAT from * 5x more, 2 sts. 3x, 3 st. 1x). [3 sts. 2x, *2 sts. 2x, 1 st. 1x, and REPEAT from * 6x more, 2 sts. 2x, 3 sts. 1x]. After Row 212 (216) [220], bind off the remaining 11 sts.

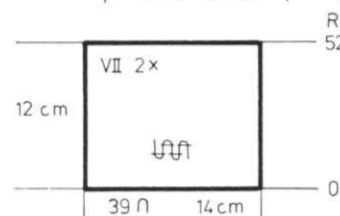

POCKET: VI Make 2.

Cast on 39 sts. and work 52 rows K1, P1 Ribbing then bind off the crochet method for Ribbing.

FRONT BANDS: VIII Make 1, reverse 1 and omit buttonholes in 2nd section.

Cast on 145 sts. and work K1, P1 Ribbing. On the LEFT (right for 2nd section), increase 2 sts. every 4th row 6x, and AT THE SAME TIME, after Row 13, make BUTTON-HOLES over needles as shown on the Chart. After Row 26, bind off the crochet method for Ribbing.

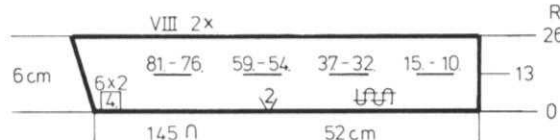

DK 325



WOMAN'S JACKET

SIZES: 8/10 [12/14] [16/18]
 YARN: Binia
 GRAMS: 550 600 650
 TENSION: 8 to 10
 GAUGE: 14 sts. 19 rows = 5 cm (2")

Stockinette stitch worn on the Purl side. Bands are K1, P1 Ribbing.
 FINISHING: See General Instructions.

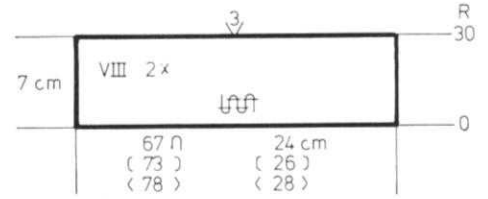
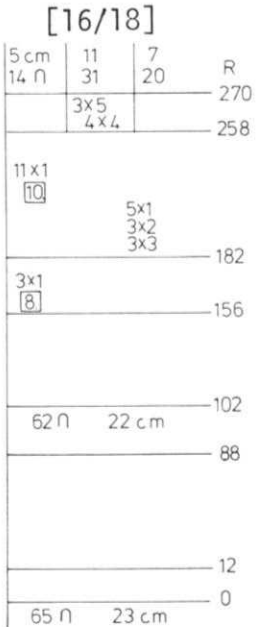
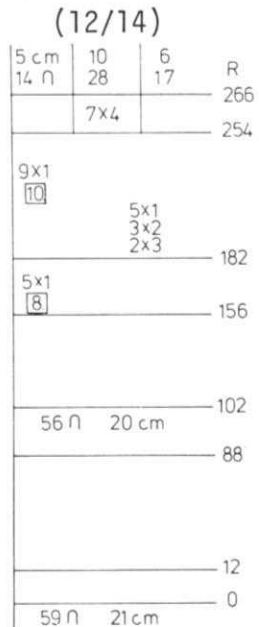
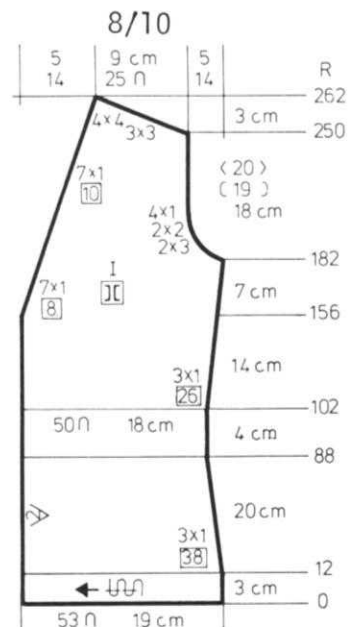
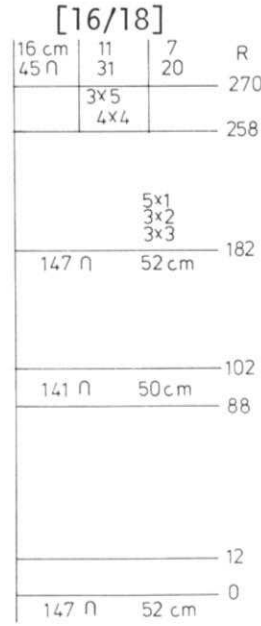
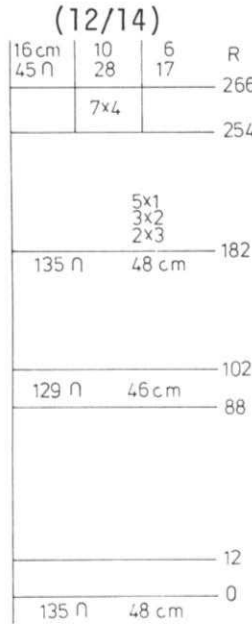
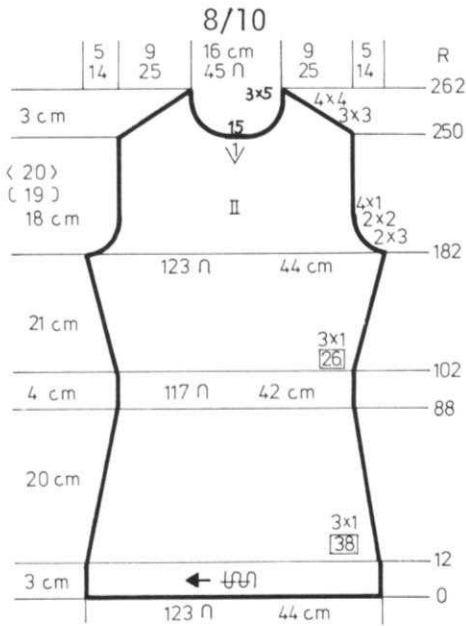

CUFFS: VIII Make 2.

Cast on 67 (73) [78] sts. and work 30 rows K1, P1 Ribbing then bind off the crochet method for Ribbing.

BACK: II

Cast on 123 (135) [147] sts. and work Stockinette stitch.
 Knit to Row 12.
 ON EACH SIDE, decrease 1 st. every 38th row 3x.
 Knit to Row 102.
 ON EACH SIDE, increase 1 st. every 26th row 3x.
 Knit to Row 182.
 SHAPE ARMHOLE: ON EACH SIDE, bind off
 3 sts. 2x, 2 sts. 2x, 1 st. 4x.
 (3 sts. 2x, 2 sts. 3x, 1 st. 5x).
 [3 sts. 3x, 2 sts. 3x, 1 st. 5x].
 Knit to Row 250 (254) [258].
 Bind off the center 15 sts., put the needles on the left into holding position and complete the right half first.
 *SHAPE SHOULDER AND NECK AT THE SAME TIME.
 FOR SHOULDER, bind off
 3 sts. 3x, 4 sts. 4x.
 (4 sts. 7x).
 [4 sts. 4x, 5 sts. 3x].
 FOR NECK, on all sizes, bind off 5 sts. 3x.
 Move the Cam Box to the left side, turn the Row Counter back to 250 (254) [258] and complete the left half. Follow the instructions from *.

FRONT: I Make 1, reverse 1.

Cast on 53 (59) [65] sts. and work Stockinette stitch.
 Knit to Row 12.
 ON SIDE EDGE, decrease 1 st. every 38th row 3x.
 Knit to Row 102.
 ON SIDE EDGE, increase 1 st. every 26th row 3x.
 Knit to Row 156.
 SHAPE FRONT: Decrease 1 st. every 8th row 7x, every 10th row 7x and AT THE SAME TIME, after Row 182, SHAPE ARMHOLE same as the back and after Row 250 (254) [258], SHAPE SHOULDER same as the back.

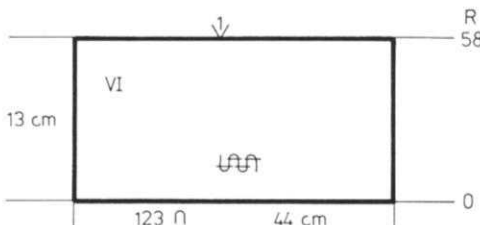

COLLAR: VI

Cast on 123 sts. and work 58 rows K1, P1 Ribbing then bind off the crochet method for Ribbing.

DK 326



WOMAN'S PULLOVER

SIZES: 8/10 (12/14) [16/18]
 YARN: Crocus
 GRAMS: 350 400 450
 TENSION: 6 to 8
 GAUGE: 15 sts. 21 rows = 5 cm (2")

An Eyelet Design that follows the Line Drawing. The knit side is the right side. Bands are K1, P1 Ribbing.

FINISHING: See General Instructions

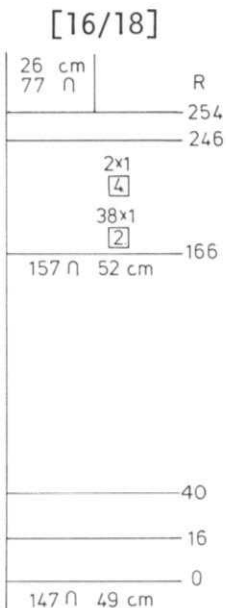
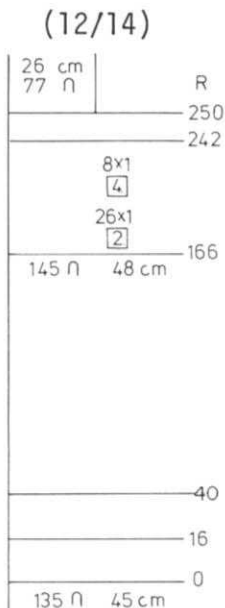
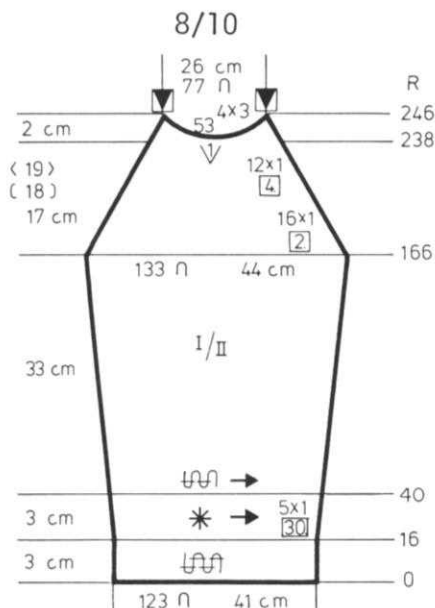

BACK & FRONT: I/II

Cast on 123 (135) [147] sts. and work 16 rows K1, P1 Ribbing. Change to the Eyelet Design and ON EACH SIDE, increase 1 st. every 30th row 5x and AT THE SAME TIME, after Row 40, change to Stockinette stitch.

Knit to Row 166. SHAPE RAGLAN: ON EACH SIDE, decrease 1 st. every 2nd row 16x (26x) [38x], every 4th row 12x (8x) [2x] and after Row 238 (242) [246], bind off the center 53 sts., put the needles on the left into holding position and complete the right half first.

*ON NECK SIDE, for all sizes, bind off 3 sts. 4x.

After Row 246 (250) [254], hang the remaining sts. together and bind off.

Move the Cam Box to the left side, turn the Row Counter back to 238 (242) [246] and complete the left half. Follow the instructions from * and don't forget to complete the raglan shaping.

NECKBAND: VIII Make 2.

Cast on 103 sts. and work 16 rows K1, P1 Ribbing then bind off the crochet method for Ribbing.

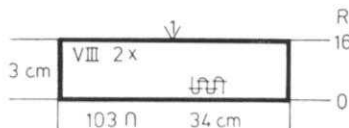

SLEEVES: III

Cast on 90 (96) [102] sts. and work 10 rows K1, P1 Ribbing. Change to Stockinette stitch with EYELET DESIGN over the CENTER 55 sts. ON EACH SIDE, increase 1 st. every 8th row 5x.

Knit to Row 48. SHAPE RAGLAN: ON EACH SIDE, on every 2nd row, decrease 2 sts. 13x (16x) [19x], 1 st. 14x (11x) [8x] and AT THE SAME TIME, after Row 98 (102) [108], bind off the center 8 sts., put the needles on the left into holding position and complete the right half first.

*ON NECK SIDE, for all sizes, bind off 3 sts. 2x. After Row 102 (106) [112], hang the remaining sts. together and bind off. Bring the needles on the left into working position, knit 1 row in Pattern to the left side, turn the Row Counter back to 98 (102) [108] and complete left half. Follow the instructions from * and don't forget to complete the raglan shaping.

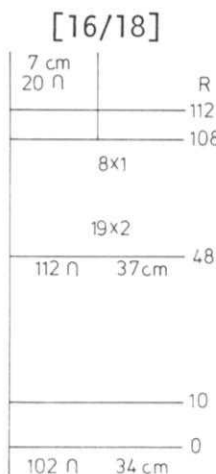
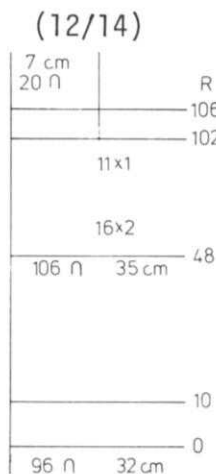
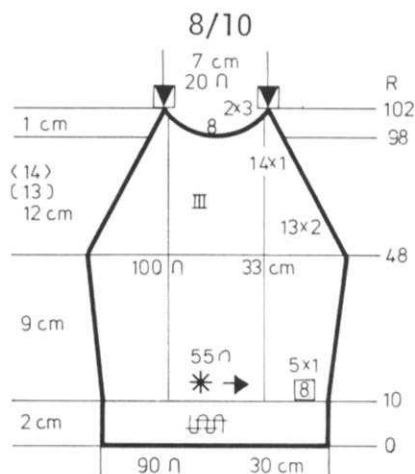



KnitKING News

PRACTICAL KNITTING HINTS

DECREASING 2 STS. ON SIDE EDGE

When a Pattern calls for you to decrease 2 sts. ON EACH SIDE, on every 2nd row, such as on the Sleeve of DK 326 in this issue, you can if you like, decrease 1 st. each side on EVERY ROW and an easy way to do this (especially when working a design) is to transfer the 2nd stitch to the first stitch, then move the doubled stitch to the 2nd needle and push the empty needle to the out of work position.

This method for decreasing 1 st. on the edge can be used for shaping sleeves in Stockinette stitch as well, especially if you do not want the full fashion method which does show the shaping.

SHORT ROWS

If you do not like wrapping the yarn when knitting Short Rows, try another method with the yarn you will use for garment to see if you like it.

Supposing you are short rowing a Bust Dart... and the pattern tells you to put into holding position 8 sts. 4x on every 2nd row. ON OPPOSITE SIDE OF CAM BOX, *put into holding position, 7 stitches., knit across, then bring the 8th stitch into holding position, knit across. REPEAT from * 3x more. Now bring all the needles into working position and knit the row. This is the method to use for the Bust Dart on the front of a cardigan or jacket. If you are working on a Pullover, you should work BOTH sides in the same way for the front section Bust Darts.

For working Short Rows on a sideways knitted Skirt, it might be necessary for you to bring the needles back into working position in order to complete a panel, so this is the method to try on a sample swatch.

Cast on 60 sts., knit 4 rows.
ON OPPOSITE SIDE OF CAM BOX, on every 2nd row, put into holding position, 10 sts. 5x in this manner. *Put 9 sts. into holding position, knit across, then bring the 10th st. into holding position, knit across. REPEAT from * 4x more. You have 10 sts. left in working position. Now bring the holding needles back into working position as follows: The first time, push back 10 sts., knit across, and bring the inside 10th st. back into holding position, knit across. Now bring back 11 sts., knit across and bring 11th stitch back into holding position... Continue to bring 11 sts. back into work, knit the row and bring the 11th back into holding until all the stitches are in work. The last time when you bring the 11 sts. back into work, DO NOT bring the 11th st. into holding. Knit 6 rows and REPEAT from the beginning. When using this method for a boucle yarn which has a nub, you will not be able to see the wrapped needle stitches on either side of the knitting... However, if you are using a smooth yarn, the stitches will show on the purl side but the knit side is very nice.. try it....

KNITKING YARNS

The very latest on the new KNITKING YARN CATALOGUE is that we have received samples and selected all colors for our 76/77 range... We are having some entirely new type cone yarns made up that will be exclusive to KNITKING and as soon as our initial order is dyed, we will tell you all about them and give you the opportunity to try them out at 'Special Introductory Prices'...



SPECIAL YARN DISCOUNTS TO KNITKING MAGAZINE SUBSCRIBERS...

We are again offering yarns at big discounts to our subscribers. You can obtain yarns to make any or all of the beautiful garments in this issue... just choose what you need from the following list and place your order as soon as possible. Don't forget you have a choice of colors. You do not have to choose the colors used in the original garments. Also try to suggest alternate colors. We carry good stocks of all colors, but some go quicker than others and giving us the opportunity to send your choice of alternates will avoid delays in getting your order to you.

Remember these special prices on beautiful KNITKING YARNS are only available to registered subscribers and they are only available until you take delivery of the JULY/AUGUST edition of KNITKING MAGAZINE at which time there will again be 'Special Prices' for subscribers on yarns used in that edition.

Zippers, Buttons, Crochet hooks and small amounts of yarn for trim or embroidery, are not included in the Kits.

BIG DISCOUNTS ON KITS for Garments in this issue.

| | | | | |
|------------------------|--------|---------|---------|---------|
| DK 297 - Yarn: Allegro | | | | |
| SIZES: | | 8/10 | (12/14) | [16/18] |
| Regular Price | \$1.59 | \$23.85 | \$27.03 | \$28.62 |
| SALE PRICE | 1.19 | 17.85 | 20.23 | 21.42 |
| Shipping costs | | 1.65 | 1.65 | 1.65 |
| DK 298 - Yarn: Allegro | | | | |
| SIZES: | | 7/8 | (10/12) | [16] |
| Regular Price | \$1.59 | \$ 9.54 | \$11.13 | \$12.72 |
| SALE PRICE | 1.19 | 7.14 | 8.33 | 9.52 |
| Shipping costs | | 1.65 | 1.65 | 1.65 |

DK 299 - Yarn: Crocus Crepe
 SIZES: 8/10 (12/14) [16.18]
 Regular Price \$2.09 \$10.45 \$12.54 \$14.63
 SALE PRICE 1.57 7.85 9.42 10.99
 Shipping costs 1.25 1.25 1.25

DK 300 - Yarn: Allegro
 SIZES: 8 (10/12) [14/16]
 Regular Price \$1.59 \$11.13 \$14.31 \$15.90
 SALE PRICE 1.19 8.33 10.71 11.90
 Shipping costs 1.65 1.65 1.65

DK 301 - Yarn: Vienna
 SIZES: 10/12 (14/16) [18/20]
 Regular Price \$1.79 \$16.11 \$17.90 \$19.69
 SALE PRICE 1.34 12.06 13.40 14.74
 Shipping costs 1.65 1.65 1.65

DK 302 - Yarn: Amore
 SIZES: 6/7 (8/10) [12.14]
 Regular Price \$1.49 \$ 7.45 \$ 8.94 \$10.43
 SALE PRICE 1.12 5.60 6.72 7.84
 Shipping costs 1.25 1.25 1.25

DK 303 - Yarn: Amore
 SIZES: 6/7 (8/10) [12/14]
 Regular Price \$1.49 \$ 4.47 \$ 5.96 \$ 7.45
 SALE PRICE 1.12 3.36 4.48 5.60
 Shipping costs 1.00 1.00 1.00

DK 304 - Yarn: Vienna
 SIZES: 8 (12) [16]
 Regular Price \$1.79 \$21.48 \$23.27 \$25.06
 SALE PRICE 1.34 16.08 17.42 18.76
 Shipping costs 2.15 2.15 2.15

DK 305 - Yarn: Amore
 SIZES: 6/7 (8/10) [12/14]
 Regular Price \$1.49 \$ 7.45 \$ 8.94 \$10.43
 SALE PRICE 1.12 5.60 6.72 7.84
 Shipping costs 1.25 1.25 1.25

DK 306 - Yarn: Crocus Crepe
 SIZES: 8/10 (12/14) [16]
 Regular Price \$2.09 \$16.72 \$18.81 \$20.90
 SALE PRICE 1.57 12.56 14.13 15.70
 Shipping costs 1.65 1.65 1.65

DK 307 - Yarn: Binia
 SIZES: 6/8 (10/12) [14/16]
 Regular Price \$1.39 \$ 8.34 \$11.12 \$12.51
 SALE PRICE 1.04 6.24 8.32 9.36
 Shipping costs 1.65 1.65 1.65

DK 308 - Yarn: Euro Sport
 SIZES: 10/12 (14/16) [18/20]
 Regular Price \$1.29 \$21.93 \$25.80 \$29.67
 SALE PRICE .97 16.49 19.40 22.31
 Shipping costs 1.65 1.65 2.15

DK 309 - Yarn: Allegro
 SIZES: 6/8 (10/12) [14/16]
 Regular Price \$1.59 \$17.49 \$19.08 \$20.67
 SALE PRICE 1.19 13.09 14.28 15.47
 Shipping costs 1.65 1.65 1.65

DK 310 - Yarn: Vienna
 SIZES: 6/8 (10/12) [14/16]
 Regular Price \$1.79 \$12.53 \$17.90 \$19.69
 SALE PRICE 1.34 9.38 13.40 14.74
 Shipping costs 1.50 1.65 1.65

DK 311 - Yarn: Micaela & Monofil
 SIZES: 10/12 (14) [16/18]
 Regular Price \$1.99 \$20.86 \$22.85 \$24.84
 SALE PRICE 2.95 15.62 17.11 18.60
 Shipping costs 2.21 1.65 1.65

DK 312 - Yarn: Crocus Crepe
 SIZES: 6/7 (8/10) [12/14]
 Regular Price \$2.09 \$25.08 \$27.17 \$29.26
 SALE PRICE 1.57 18.84 20.41 21.98
 Shipping costs 1.65 1.65

DK 313 - Yarn: Nicole
 SIZES: 14/16 (18/20) [22/24]
 Regular Price \$1.79 \$10.74 \$12.53 \$12.53
 SALE PRICE 1.34 8.04 9.38 9.38
 Shipping costs 1.25 1.25 1.25

HP 314 - Yarn: Crocus Crepe
 SIZES: 34/36 (38/40) [42]
 Regular Price \$2.09 \$12.54 \$14.63 \$16.72
 SALE PRICE 1.57 9.54 10.99 12.56
 Shipping costs 1.25 1.25 1.25

HP 315 - Yarn: Fortissima
 SIZES: 34/36 (38) [40/42]
 Regular Price \$1.59 \$11.13 \$12.72 \$14.31
 SALE PRICE 1.19 8.33 9.52 10.71
 Shipping costs 1.65 1.65 1.65

KK 316 - Yarn: Allegro
 SIZES: 6/7 (8/9) [10/11]
 Regular Price \$1.59 \$ 4.77 \$ 6.36 \$ 7.95
 SALE PRICE 1.19 3.57 4.76 5.95
 Shipping costs 1.00 1.00 1.00

KK 317 - Yarn: Allegro
 SIZES: 6/7 (8/9) [10/11]
 Regular Price \$1.59 \$ 6.36 \$ 6.36 \$ 7.95
 SALE PRICE 1.19 4.76 4.76 5.95
 Shipping costs 1.00 1.00 1.00

KK 318 - Yarn: Allegro
 SIZES: 9/10 (11/12) [13/14]
 Regular Price \$1.59 \$11.13 \$11.13 \$12.72
 SALE PRICE 1.19 8.33 8.33 9.52
 Shipping costs 1.65 1.65 1.65

KK 319 - Yarn: Allegro
 SIZES: 3/4 (5/6) [7/8]
 Regular Price \$1.59 \$ 9.54 \$ 9.54 \$11.13
 SALE PRICE 1.19 7.14 7.14 8.33
 Shipping costs 1.25 1.25 1.25

KK 320 - Yarn: Amore
 SIZES: 4/5 (6/7) [8/9]
 Regular Price \$1.49 \$ 5.96 \$ 7.45 \$ 8.94
 SALE PRICE 1.12 4.48 5.60 6.72
 Shipping costs 1.00 1.00 1.00

KK 321 - Yarn: Allegro
 SIZES: 1/2 (3/4) [5/6]
 Regular Price \$1.59 \$ 3.18 \$ 4.77 \$ 6.36
 SALE PRICE 1.19 2.38 3.57 4.76
 Shipping costs 1.00 1.00 1.00

HP 322 - Yarn: Euro Sport
 SIZES: 38/40 (42) [44/46]
 Regular Price \$1.29 \$23.22 \$24.51 \$25.80
 SALE PRICE .97 17.46 18.43 19.40
 Shipping costs 1.65 1.65 1.65

HP 323 - Yarn: Crocus
 SIZES: 34/36 (38/40) [42]
 Regular Price \$2.09 \$31.35 \$35.53 \$35.53
 SALE PRICE 1.57 23.55 26.69 26.69
 Shipping costs 1.65 1.65 1.65

HP 324 - Yarn: Binia
 SIZES: 34/36 (38) [40/42]
 Regular Price \$1.39 \$20.85 \$22.24 \$23.63
 SALE PRICE 1.04 15.60 16.64 17.68
 Shipping costs 1.65 1.65 1.65

DK 325 - Yarn: Binia
 SIZES: 8/10 (12/14) [16/18]
 Regular Price \$1.39 \$15.29 \$16.68 \$18.07
 SALE PRICE 1.04 11.44 12.48 13.52
 Shipping costs 1.65 1.65 1.65

DK 326 - Yarn: Crocus
 SIZES: 8/10 (12/14) [16/18]
 Regular Price \$2.09 \$14.63 \$16.72 \$18.81
 SALE PRICE 1.57 10.99 12.56 14.13
 Shipping costs 1.65 1.65 1.65



knitking accessory price list

| | PRICE | SHIPPING | | PRICE | SHIPPING |
|--|---------|----------|---|-------|----------|
| WHIZ KING PATTERN READER - complete with Converta Tape & 2 sheets of graph transparent plastic | \$79.50 | \$2.75 | Reversing Bar (197 Needle KNITKING Machine only | 39.95 | 2.00 |
| 3-Color Yarn Feeder | 29.50 | 1.65 | Converta Tape (for charting Patterns to size) | 10.95 | .65 |
| Pattern Stitch Cards for AM 3 KNITKING Machine only #17 to #48 | 10.50 | 1.40 | Fluorescent Magnifying Lamp with 5 inch lens and adjustable 45 inch extension arm (specify table clamp or wall fitting) | 69.50 | 3.50 |
| Weaving Accessory for AM 3 KNITKING only | 8.95 | .85 | Lumaglo Lamp | 24.95 | 1.75 |
| Adjustable Needle Selector (33 needle) | 4.95 | .60 | JAC 40 (KNITKING Machine only) . . . | 37.50 | 1.75 |
| Cam Wheels for AM 3 KNITKING Machine only each | 1.75 | .15 | JAC 40 Punch Cards. Please give alternate numbers each | 1.50 | .15 |
| Knitting Table (suitable for all machines | 39.50 | F.O.B. | JAC 40 Punching Accessory with 5 blank cards | 24.95 | 1.25 |
| Treble Transfer Tool (pair) | 3.50 | .55 | Blank Cards each | 1.00 | .15 |
| Multiple Transfer Tool (33 needle). . | 4.50 | .65 | Strap for JAC 40 | 2.00 | .30 |
| Double Transfer Tool (pair) | 2.50 | .55 | KNITKING Instruction Book (specify machine) | 4.00 | .55 |
| Transfer Tools (1 each - 4 needle and 6 needle) | 3.25 | .55 | KNITKING AM 3 Book - complete with Home Study Course | 12.95 | .65 |
| Combined Latch Needle & Transfer Tool | 1.50 | .30 | Inches/Centimeters Tape Measure . . . | .49 | .20 |
| Combined Work Hook & Transfer Tool | 1.50 | .30 | 1 Year Subscription to KNITKING MAGAZINE (6 issues) | 10.00 | (no tax) |
| Knitting Machine Needles for KNITKING Machines only | .55 | .15 | Canada | 12.00 | |
| Ribbing Attachment Needles for KNITKING Ribbers only | .65 | .15 | Back Issues of KNITKING MAGAZINE | | |
| Ribber Transfer Needles | .45 | .15 | Single Copy (thru Vol.10) . . .each | 1.50 | Postpaid |
| Strippers for KNITKING Ribber (pair). . | .95 | .25 | From Vol 11 No. 1 each | 3.00 | Postpaid |
| KNITKING Sinker & Spring (specify Machine No.) | .25 | .15 | KNITKING MAGAZINE | | |
| Shipping for 20 | | .50 | Plastic bound Volumes (6 issues) | | |
| Yarn Winder with 'Waxamajig' and Skein Holder | 27.50 | 2.00 | Bound Volumes 9 or 10 each | 7.95 | 1.25 |
| Wax Spools each | .30 | .25 | Bound Volume 11 each | 11.95 | 1.50 |
| or 4 for | 1.00 | .50 | Canada & Mexico | | 3.00 |
| | | | All other countries | | 3.65 |
| | | | Carrying Bags | | |
| | | | AM 3 Knitter | 45.95 | 2.00 |
| | | | P 3 Ribber | 24.00 | 1.25 |

Sorry, no C.O.D's or Billings. Please send money with your order. California Residents, add Sales Tax. Effective January 1, 1976
Price Lists prior to this date are obsolete.

KNITKING, INC.
1128 Crenshaw Blvd., Los Angeles, California 90019



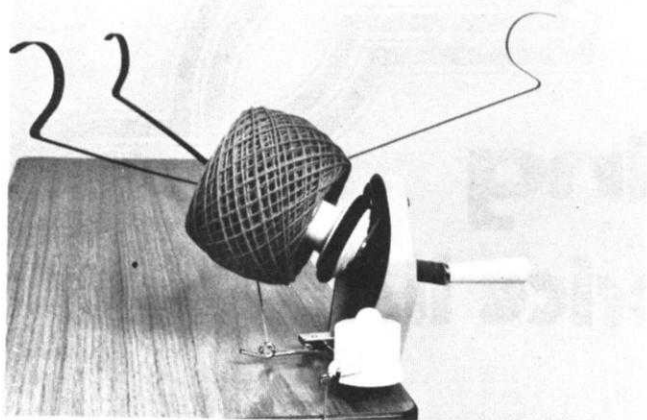

New design Yarn Winder with 'Waxamajig' and Skein Holder. As you can see from the illustration, this clever New Winder with Nylon Helical Gears winds a perfectly symmetrical ball...! If you like to wax yarn (for easier knitting) you use the 'Waxamajig'. If waxing is not necessary, you bypass it... The Skein Holder is self adjusting. You will not find a better Hand Winder anywhere.

Complete price \$27.50
(California residents add Sales Tax)
 Shipping Charges: \$2.00

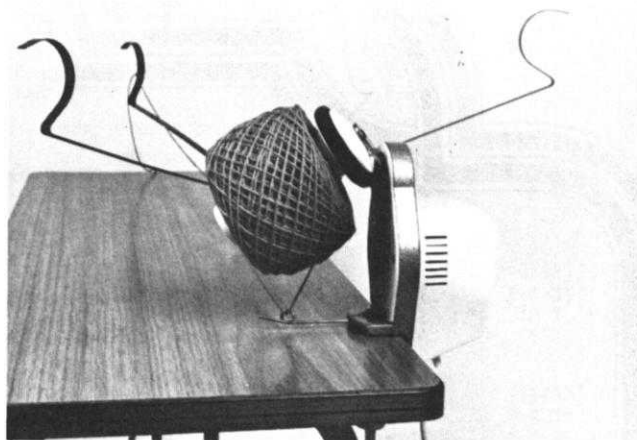

New design electric winder

Self-contained Motorized Winder (110/120 Volts) with Push Button on and off Switch... Special Clutch device to stop Winder if yarn bunches up or jams in the guide eye... Another excellent easy to use KNITKING product.

Price: Complete with Skein Holder \$44.95
(California residents add Sales Tax).
 Shipping Charges: \$3.00



knitking carrying bags

Completely new design in heavy duty canvas with waterproof interior. For AM 3 Knitter and Yarn Container.

Price: \$46.50
 For Ribber only: \$23.00
(California residents add Sales Tax)
 Shipping Costs: \$2.00 and \$1.25

Order direct from KNITKING —
 1128 Crenshaw Blvd., Los Angeles, California 90019

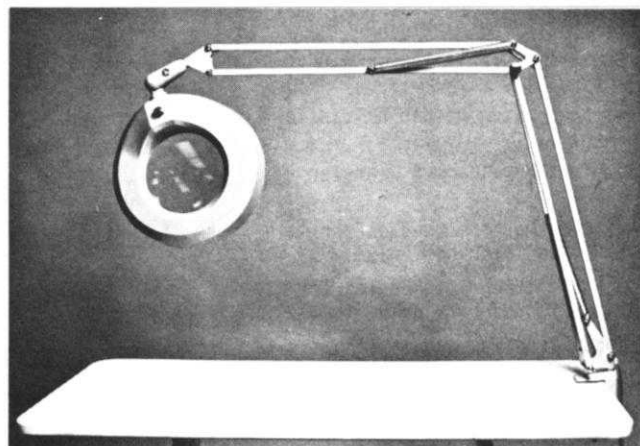

knitking magnifier lamp

A perfect gift item for any knitter. It has a large (5") magnifying lens and a cool fluorescent tube light. It stays in any position and is wonderful for general illumination for you to work under when joining seams, etc. Color: light grey.

Price: \$69.50
(California residents add Sales Tax)
 Shipping Costs: \$3.50



DK 300





DK 306

DK 304

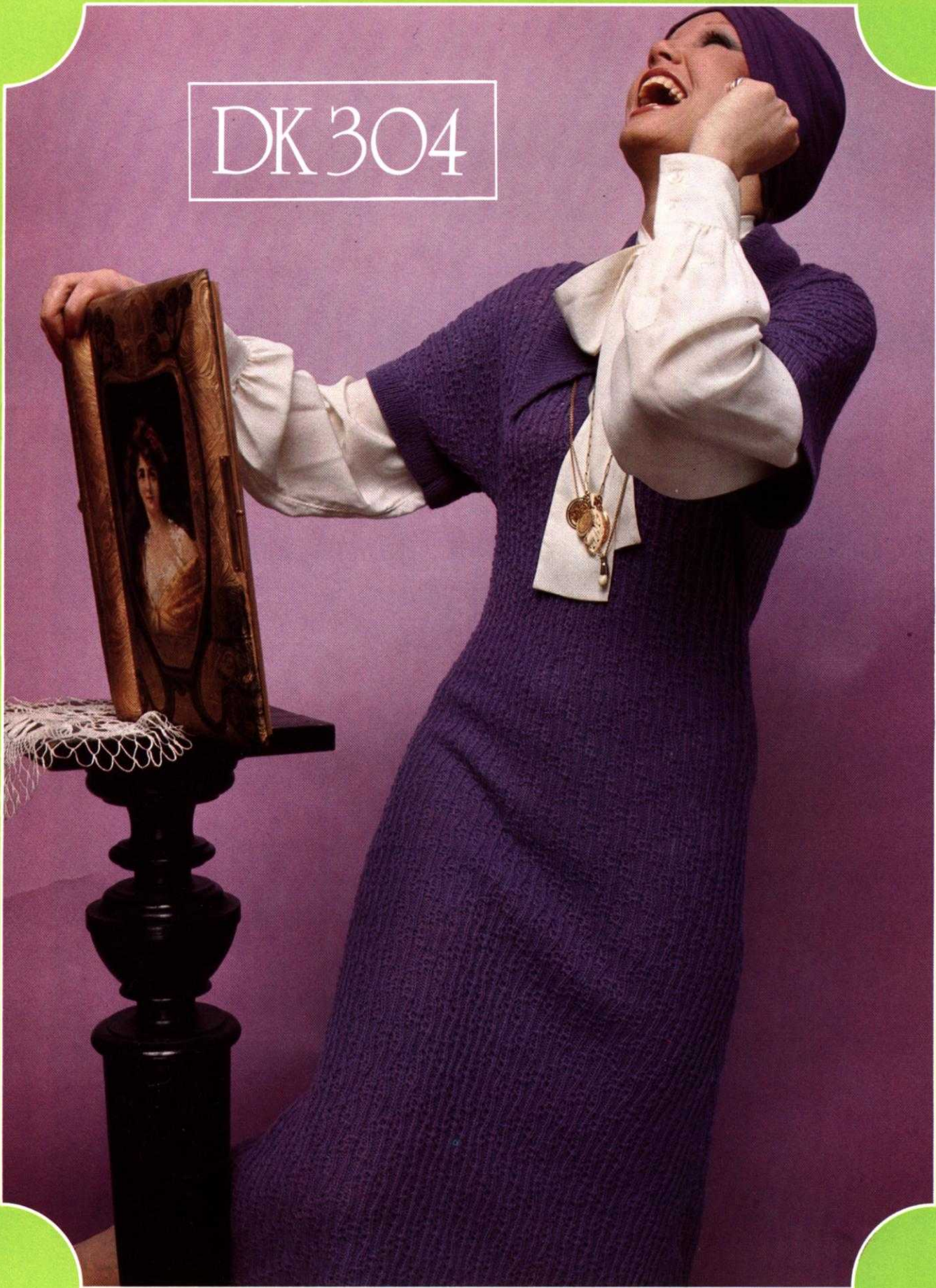

DK 311





DK 299

DK 307

DK 302



DK 305

DK 303



DK 313

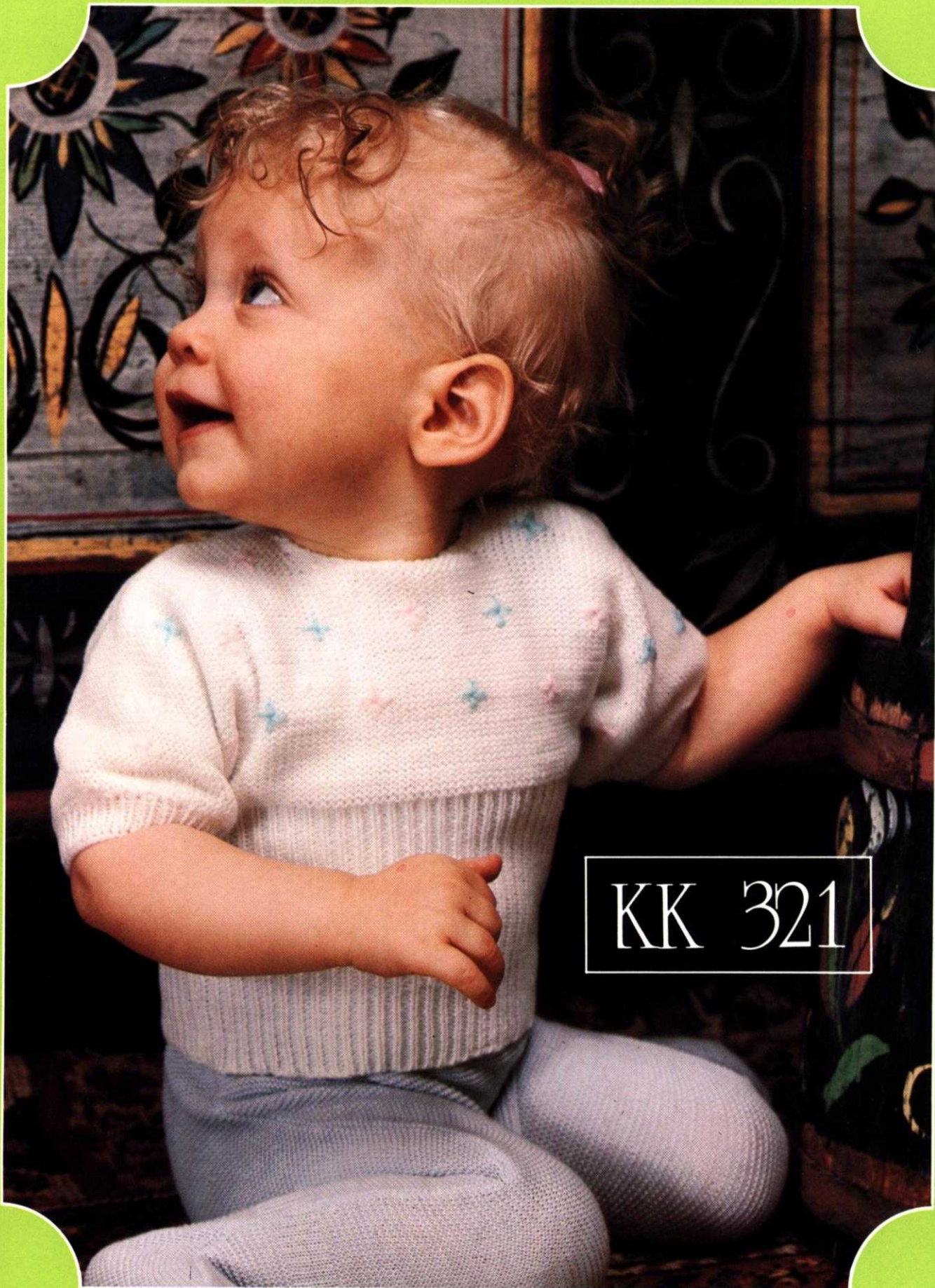

KK 321

