

A woman with blonde hair is wearing a red wide-brimmed hat, a red top, a yellow knit cardigan, and a yellow knit skirt with a red belt. She is standing outdoors in a garden-like setting with trees and a white archway in the background. The magazine title 'knitking' is in red, and 'magazine' is in a yellow script font below it.

knitking

magazine

Ben

**SUPER
SOUTHWEST
SWEATERS**

Intarsia for the
Whole Family

**DAYTIME
TO
EVENING**

Garments for
All Occasions

**HELPFUL
KNITTING
HINTS**

New ideas
from experts

VOLUME 24 ISSUE 2

836

Texture Variations

Three different textures complete a perfect three piece suit you will wear and wear. The fabulous jacket is a weaving design using Venetia, Pebble and Bright Filler; the skirt Stockinette stitch is in Venetia and the pretty Shell knitted with Sorbet is a Tuck Stitch. All can be knitted on any Standard or Electronic machine.



837

Slim and Trim

The clever shaping of a surplice bodice is flattering to most any figure and the stark simplicity of this lovely two color dress will more than please you. It's easy to knit on Standard or Electronic machine. Venetia is the yarn.



TABLE OF CONTENTS

EDITORIAL

KNITTING MAGAZINE - VOLUME 24 NO. 2

0000	GENERAL INSTRUCTIONS	11
835	3-PIECE ENSEMBLE WITH SCARF-WRAPPED SKIRT	13
836	3-PIECE ENSEMBLE WITH WOVEN JACKET	15
0000	HINTS FROM READERS	19
837	TWO-COLOR DRESS	20
838	2-PIECE LACE DRESS	22
839	WOMENS SOUTHWEST INTARSIA PULLOVER	23
840	MENS SOUTHWEST INTARSIA PULLOVER	26
841	BOYS SOUTHWEST INTARSIA PULLOVER	28
842	GIRLS SOUTHWEST INTARSIA PULLOVER	30
843	RACKED-RIB SUIT WITH TANK TOP	34
844	2-PIECE FAIRISLE DRESS POSITIVE/NEGATIVE	32
845	OVERSIZE PULLOVER WITH RANDOM MOTIFS	36
0000	INNOVATIVE KNITTING TECHNIQUES	38
846	TUCK STITCH PULLOVER	39
847	MENS BULKY TUCK RAGLAN PULLOVER	40
848	2-PIECE DRESS WITH TUCK SKIRT	41
849	MENS DROP SHOULDER TUCK PULLOVER	43
850	V-NECK PULLOVER WITH FAIRISLE INSET COLLAR	44
0000	TECHNICAL TIPS	45
851	MENS GARTER CARRIAGE AND CABLE PULLOVER	46
852	WOMENS SIDEWAYS DOLMAN	50
853	GIRLS OVERSIZE GARTER CARRIAGE PULLOVER	51
854	MULTI-COLOR DOUBLE KNIT PULLOVER	52

Dear Readers . . .

What a whirlwind few months this has been since I last had a chance to bring you up to date on all the Knitking happenings! As mentioned in our previous issue of Knitking Magazine, Knitking knitting machines were a featured segment on the ABC National morning show, The Home Show. The show's host, Gary Collins, is crazy about sweaters. So much so, that he wears one every day on The Home Show. He was so impressed with Knitking knitting machines and their capabilities that he persuaded the Home Show staff to approach Knitking with the hopes of having us fashion his sweater wardrobe for the spring season. We went to town and created over 30 sweaters for Mr. Collins to wear on the air. (Many of these will be featured in this issue and future issues of Knitking Magazine.) The Home Show staff was delighted with the designs and wanted to share with their viewing audience how the designs for these beautiful sweaters were created. So, June 28, Home Show crafts specialist, Carole Duvall, demonstrated the Knitking Pattern Design Computer, and showed just how easy it is to create a design and knit a garment. Sweaters bearing the "Home Show" logo were knitted especially for the show. Once again, the public responded enthusiastically to the demonstration. The modern electronics of the Compuknit IV knitter combined with the Pattern Design Computer had the viewers entranced.

Although the Home Show viewers were mesmerized by the Compuknit IV and were shown why it is the most popular advanced knitting machine in America, we are not resting on our laurels here at Knitking. Indeed, we are proud and excited to now introduce the bulky counterpart to the Compuknit IV—the Knitking Compuknit/Bulky. This machine will be the ultimate in electronic knitting for heavier gauge yarns. We enthusiastically expect it to take its rightful place next to the Compuknit IV and share the #1 spot. Please see the insert in this issue for further information on the new Compuknit/Bulky.

We had a great time designing the wide variety of garments presented in this issue and hope you have a super time knitting your favorites.

Suzanne Str

835

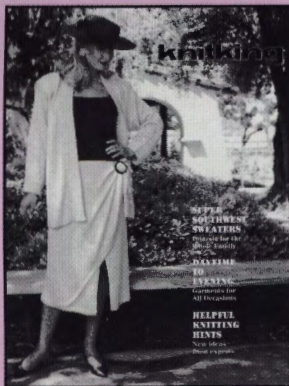

Summer Sensation

A smashing three piece ensemble will take you through all the glorious days or nights of summer. It can be knitted on any Standard or Electronic machine in easy stockinette stitch. A bonus of a draped Scarf is included and is shown attached to the slim slit Skirt. Knit it with our elegant Pearlyte.

Publisher: KNITTING CORPORATION, 1128 Crenshaw Blvd., Los Angeles, CA 90019. Telephone: (213) 938-2077 Published quarterly. Subscription: USA-\$24.00 annually, single copies \$6.95. \$29.00-all other countries. The entire contents of KNITTING MAGAZINE are copyrighted and must not be reproduced in any shape or form without the express permission, in writing, of the publisher.
©COPYRIGHT 1990 KNITTING CORPORATION

A woman with her hair pulled back, wearing a white two-piece lace dress, stands leaning against a large tree trunk in a wooded area. The dress features a delicate, repeating diamond-shaped lace pattern. The background is filled with sunlight filtering through the trees, creating a dappled light effect on the ground covered in dry leaves and twigs.

838

Designers Lace

No summer wardrobe is complete without an attractive Lace Dress. Knit this two piece beauty with our Lumiyarn/Pearlyte for a sparkling effect.

Wings yarn for the rolled Collar adds the perfect feminine trim. Knit it on any Electronic machine with Lace Carriage.

839

Southwest Intrigue

Take time out for a picnic wearing this lovely cropped Sweater that boasts a colorful Intarsia Design. Trim it with a knotted and beaded Fringe that will dance as you move. It's fun to knit on any Bulky machine with Intarsia capabilities using our popular Sof-ton yarn.

840

Southwest Encore

Delight your man with the masculine version of a Southwest Intarsia Design Pull-over to be worn everywhere. Stripes on lower edge and sleeves are part of the design. The yarn is Softon and it's knitted on a Bulky machine with Intarsia capabilities. A ribber is needed for the bands.



841 842

A Family Affair

Southwest Designs made for a Boy and Girl are colorful and the perfect sweaters to wear on vacation or at home. Knit both of them on a Bulky machine with Intarsia capabilities. A ribber is needed for the bands. Trim the Girl's Sweater with delightful accents using Beads, Fringe and metal Conchos. Softon is the yarn.



843

Sculptured Appeal

A three piece Suit that is different and charming. The Skirt and Jacket is knitted on a Standard or Electronic machine and Ribbing Attachment with our Venetia and is a Racking Pattern. Knit the Shell with Sorbet in a Tuck stitch.



844

Geometric Appeal

Catch every eye when you wear this striking two piece Dress and listen for compliments. It's a Fair Isle Design knitted on the Compuknit III or IV. The Bands are 1 x 1 Ribbing and the yarn is Sorbet.



845

Blocks of Fashion

Isolated Fair Isle forms interesting patches of color on an easy to knit oversized Pullover you will love to wear. Knit it on the Punch Card Bulky using Sof-ton. The Bands are ribbed.



GENERAL INSTRUCTIONS

THE SAMPLE SWATCH

It is imperative that you knit a sample swatch for every garment. Although you may be using the identical yarn and machine model as the pattern suggests, many variables such as dye lot difference, speed of knitting and just machine to machine differences can all cause a variance in the gauge achieved. Knitmagazine Magazine publishes the tension and gauge for each garment shown. We strongly urge you to knit a swatch representing three tensions - the recommended tension, and .1 or .2 higher and lower. These different tensions can be knitted in one piece with waste yarn separating the sections. This will eliminate unnecessary rethreading while allowing you to obtain the gauge published in the magazine.

To make a sample swatch on standard gauge machines cast on 60 stitches with waste yarn. Knit approximately 6 rows. *Mark the tension number for your swatch by making holes. For example 4 eyelet holes for Tension 4, 6 eyelet holes for Tension 6. Knit 6 more rows.

Change to garment yarn and reset row counter to 0. Knit 30 rows (in Pattern stitch). With contrast yarn, mark the 10th stitch FROM EACH SIDE by hand. Knit 30 Rows. Change to waste yarn and knit 6 rows. Change tension up or down for second section and repeat from *. Make third section with another tension. Remove on 12 Rows of waste yarn. Remove the sts. from the machine

by pushing the Carriage across without yarn.

Pull and stretch the swatch both lengthwise and diagonally from corner to corner. Gently block the swatch. Treat the swatch as you would the finished garment before measuring the gauge. For example, if you plan to wash this garment and dry it in the dryer, you should do so, measuring before and after to see the difference.

Measure between the stitches marked and the beginning and ending rows for the inches/cms. knitted. Divide the total number of stitches/rows by the inches measured to calculate sts. and rows per inch.

For Bulky knitters, make swatch with 30 Sts. and 30 Rows. If so desired, or for large pattern repeats, we suggest a wider and longer swatch to provide more accurate gauges.

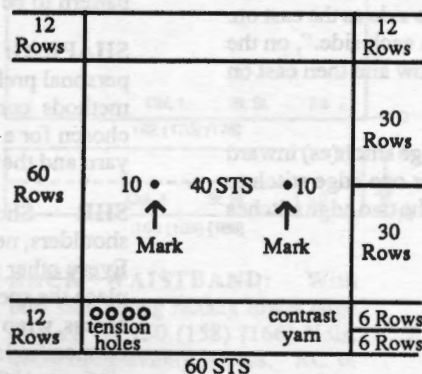

HEMS

Two methods of knitting hems are described below. Variations on these instructions will allow you to knit plain hems, picot edge hems and more.

Method One

With waste yarn cast on the required number of stitches and knit about 10-12 rows ending with the carriage on the left. Knit 1 Row to the right with Ravel Cord. Change to garment yarn and knit 1 Row to the left at garment body tension. (i.e. Skirt at Tension 4, 1st row at T 4). Turn tension down approximately 2 full tension numbers lower (tighter) and knit to mid point. (i.e. Row 14 of a 28-row hem). Change tension to 1 full point lower than garment body and knit remainder of hem rows. Pick up the stitches from the first row of garment yarn - shown between the stitches of Ravel Cord. Hem is now completed. Proceed with pattern as per chart and instruc-

tions. Remove waste yarn and Ravel Cord when you have completed section.

Method Two

Bring required number of needles to "B" (working) position. Attach cast-on comb. Beginning with the 2nd needle on the LEFT, bring every other needle to "D" or "E" position. Push in both Part buttons. Knit 1 Row to the left. Release the part buttons and drop the cast-on comb. (DO NOT REMOVE cast on comb from work). Knit required number of rows for hem. Attach weights to the back of work close to the cast-on comb (about 1/4" above the comb). Beginning with the 1st needle on the LEFT, bring every other needle to "D" position. Carefully LIFT the cast-on comb and hang loops onto the needles in "D" position. Turn the comb back away from you and make sure the needles are through the loops. Pull the needles out to "E" position and remove the cast-on comb.

BUTTONHOLES

The following methods of buttonholes are the general manner in which small and large buttonholes are created.

Small Buttonholes in Ribbing
Make small eyelet style buttonholes by following chart below.

Buttonhole Transfer
Center St. of Each Bed to
Next St. of Other Bed



Large Buttonholes in FNR
Vertical buttonholes are made by knitting each side separately (partial or short-row knitting). Knit the right side first, end with yarn on left. Without breaking yarn, knit left side. The strand of yarn inside the buttonhole can be picked up every other row when knitting the left side, but this is not necessary for a small buttonhole.

SHORT ROWS

Method One

With carriage on opposite side start placing appropriate number of ndls in HP. Knit across and wrap the inside needle. Again, place appropriate number of ndls in HP on opposite side from carriage, knit across and repeat wrapping. The wrapping will eliminate any holes in the knitting.

Method Two - Automatic Wrap

Example follows for shoulder short rows. This method can be used for other Short Rowing as well. For example if pattern says to Short Row at shoulder every other row 7 sts, 1 x and 6 sts. 1 x . . . With carriage on opposite side put 6 sts in HP, knit 1 row across and put one additional needle in HP. Opposite carriage place 6 ndls in HP. Knit 1 row across and bring one

AT THE SAME TIME - Two functions are to be performed at the same time, such as shaping the neck and shoulder. Be sure to read both instructions before proceeding.

BO - Bind Off. To take off more than 1 St. at a time. When two or more stitches are to be bound off (or cast on) the carriage and yarn must be on the same side as the bind off. If the instruction is, "At R 100 BO 6 Sts on each side.", on the carriage side BO six stitches, knit one row and then bind off six stitches on the other side. See **DECR** and **FF DECR**.

BOLT - Slip Stitch **Bind Off** with a **Latch Tool**. Knit one row to the left at a tension at least five numbers higher (looser) than the garment tension. Bring all needles to holding position ("E") and then, pick up the first stitch on a latch tool allowing it to slip behind the latch, then pick up the next stitch and pull it through the stitch already on the latch hook, thus creating a slip stitch. If you cannot set the tension at least five full tension numbers higher, knit a row loosely manually.

CO - Cast on stitches for knitting. In our instructions, **CO** is used either for a finished edge at the beginning of the garment, or to add edge stitch(es). If two or more stitches are to be cast on the carriage and yarn must be on the same side as the cast on. If the instruction is, "At R 100 CO 6 Sts on each side.", on the carriage side cast on six stitches, knit one row and then cast on six stitches on the other side.

DECR - Use the transfer tool to move the edge stitch(es) inward to the next needle. Usually used to transfer one edge stitch to the next needle, but may be used to transfer the two edge stitches to the next two needles.

EON - Every other needle

EOR - Every other row

EOS - Every other stitch

FF DECR - Used to make an even edge for seaming and decorative seams for raglans. If one stitch is to be decreased, use a two-prong transfer tool to move the two edge stitches inward one needle. If two stitches are to be decreased, use a three-prong transfer tool to move the three edge stitches in two needles. If three stitches are to be decreased, use two two-prong transfer tools and move the edge stitches in four needles. See **DECR**, **BO** and **SHAPING**.

FF INCR - To increase one stitch move the two edge stitches outward one needle, then fill the empty needle by picking up a bar from the row below and hanging it on the empty needle.

FNR - Full Needle Rib

G.C. - Garter Carriage

HP - Holding position or "E" position.

INCR - Increase. Usually used for "full-fashion" shaping, see **FF Incr.**, or in conjunction with short row shaping. A simple **incr** can be made by pulling additional needle on side of carriage out to "E" position and knit across.

MB - Main Bed

MC - Main Color

Ndls - Needles

NWP - Non-working position or position "A"

R(s) - Row(s)

RB - Ribber Bed

RC - Row Counter.

RC 0 - Set RC to zero.

SET PATTERN - Follow the step-by-step instructions in your manual for setting the pattern and carriage controls for the pattern to be knit, e.g., Fairisle, tuck, single motif, etc.

SHAPING: The method used for shaping is a matter of personal preference. In our definitions we have described the methods commonly in use at Knitking. Which method is chosen for a particular pattern depends upon the garment, the yarn and the personal preference of the designer.

SHR - Short Row or Partial Knitting. Used for shaping shoulders, necklines, darts, gores, etc. Set carriage on H(old). **Every other row SHRs**: On the opposite side of the carriage, place the specified number of stitches in holding position, knit across, wrap the inner needle or use an "automatic wrap". After all specified stitches have been placed in HP change the carriage setting to N (knit) to return the needles to WP. **Every row SHRs**: On the side being shaped, place one stitch in HP every row. It is recommended you refer to your manual or an instruction book for detailed instructions about how to short row.

St(s) - Stitch(es)

St. St. - Stockinette stitch.

T - Tension.

WP - Working Position or "B" position.

WY - Waste yarn.

YM - Yarn marker. To place a yarn marker, use a short piece of contrasting yarn and loop it over the needle specified or the end needle of the row specified.

SEAMING GARMENTS

Any number of popular methods are suggested. We encourage you to experiment with any and all. If a garment in Knitking Magazine requires special seaming information it will be provided in the individual pattern instruction. Otherwise, methods include: linking on the knitting machine, Knitking's Lectrolink- the electric linker, crochet slip stitch, tapestry needles with back stitch sewing by hand, bar-to-bar weaving for seamless appearance, and seaming on a sewing machine.



3-PIECE ENSEMBLE WITH SCARF-WRAPPED SKIRT

YARN:

Pearlyte

SIZES:

6/8 (10/12) [14/16]

AMOUNT:

Col. 1: Goldenrod
2 1/2 lb. (3 lb.) [3 lb.]
Col. 2: Red
10 oz. (10 oz.) [1 lb.]
Col. 3: Monofil (1 spool)
Col. 4: Knit-in Elastic-Red
(4 spools all sizes)

KIT PRICE:

\$71.00 (\$82.00) [\$90.00]

TENSION:

Jacket: T 4
Jacket Rib Band: T 3/2.2 I
Skirt: T 4.1 and T 4
Camisole: T 2.2/2.1 I

GAUGE:

Jacket Body:
7.73 Sts., 12.39 Rs = 1"
Jacket Rib:
15.2 Sts., 12.8 Rs = 1"
Skirt Body:
8.5 Sts., 11.07 Rs = 1"
Skirt Wrap:
8.5 Sts., 11.35 Rs = 1"

NOTIONS: Round "t-shirt" buckle to cover for wrap

Make on Standard Gauge machine with Ribber. Garment is worn on the knit side.

JACKET BACK: With WY CO 162 (170) [178] Sts. After several rows, end with 1 row Ravel Cord to the right. RC 0. T 4. Change to Col. 1. Knit in St. St. to R 174 (180) [186] and mark both sides with YM for armhole. Continue in straight St. St. knitting to R 288 (300) [312]. Begin SHR shoulder shaping on each side EOR 5 Sts. 8 x for all sizes. At R 298 (310) [322] begin back neckline shaping.

Place center 16 (20) [24] Sts in HP and all Sts to the left. Continue SHR shoulder shaping while shaping right neckline. *On neckline edge, EOR BO 7 Sts. 3 x. At R 304 (316) [328] knit 1 R at T 10 over all remaining shoulder Sts. and BOLT. Reset RC to 298 (310) [322] and shape left shoulder and neckline edge from *.

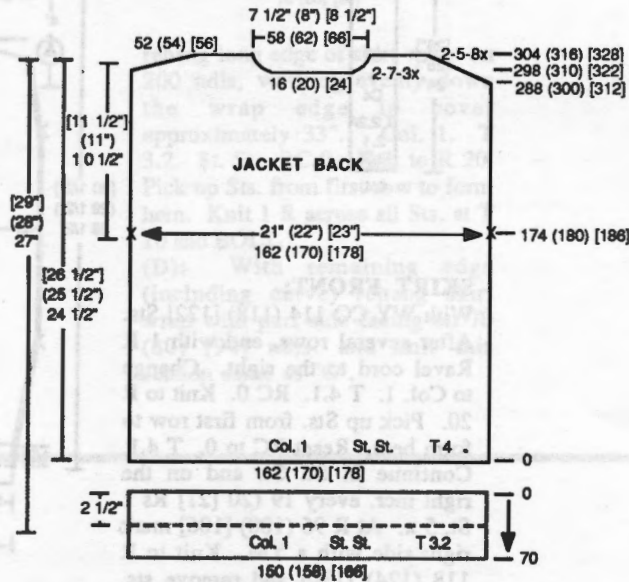

BACK WAISTBAND: With purl side facing rehang lower edge of back on 150 (158) [166] Ndl's, decreasing evenly across. RC 0. T 3.2. Col. 1. St. St. Knit to R 70. Pick up Sts. from first row to form double band. Knit 1 R at T 10 and BOLT.

JACKET FRONT:

Make 1, Reverse 1. With WY CO 81 (85) [89] Sts. After several rows, end with 1 row Ravel Cord to the right. RC 0. T

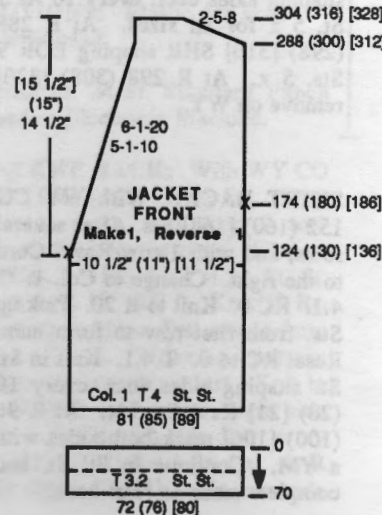

4. Change to Col. 1. Knit in St. St. to R 124 (130) [136]. Begin neckline shaping every 5 Rs decr. 1 St. 10 x, and every 6 Rs 1 St. 20 x for all sizes. At R 174 (180) [186] mark opposite side with YM for armhole. Continue in St. St. to R 288 (300) [312]. Begin SHR shoulder shaping on each side EOR 5 Sts. 8 x for all sizes. At R 304 (316) [328] knit 1 R at T 10 over all remaining shoulder Sts. and BOLT. Knit other side of front same as above, reversing shaping.

FRONT WAISTBAND: With purl side facing rehang lower edge of back on 72 (76) [80] Ndl's, decreasing evenly across. RC 0. T 3.2. Col. 1. St. St. Knit to R 70. Pick up Sts. from first row to form double band. Knit 1 R at T 10 and BOLT.

SLEEVE: With main yarn 'e' wrap CO 104 (110) [116] Sts. RC 0. Col. 1. T 4. Knit in St. St. while shaping sleeve. On both sides every 7 Rs incr 1 St 20 x and every 8 Rs 1 St 4 (5) [6] x. At R 174 (180) [188] knit 1 R across all Sts. at T10 and BOLT.

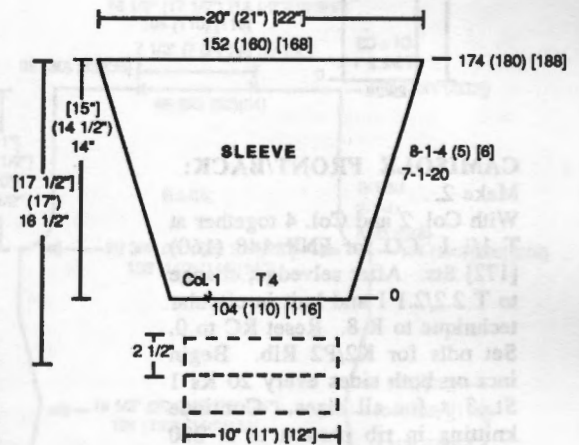

JACKET FRONT BAND:

Make 2. With Col. 1 and Col. 3 together, CO for FNR with 38 Sts. on MB and 37 Sts. on RB. After selvedge set ndls for 2x1 on MB and 1x2 on RB. (See chart.) T 3/2.2 I. RC 0. Knit to R 810 (830) [856] and BO.

Needle Chart for Jacket Front Band and Cuff

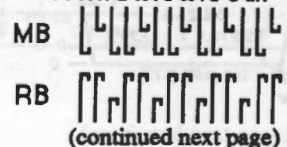

(continued from previous page)

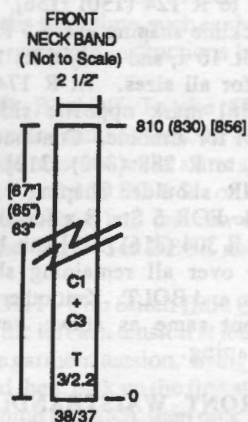

SLEEVE CUFF:

Make 2. With Col. 1 and Col. 3 together, CO for FNR with 29 Sts. on MB and 28 Sts. on RB. After selvedge set ndls for 2x1 on MB and 1x2 on RB. T 3/2.2 I. RC 0. Knit to R 130 (140) 152] and BO.

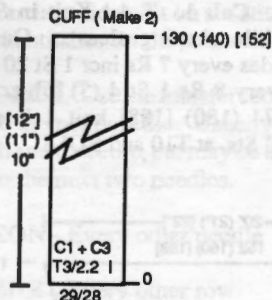

CAMISOLE FRONT/BACK:

Make 2.

With Col. 2 and Col. 4 together at T 1/1 I CO for FNR 148 (160) [172] Sts. After selvedge, change to T 2.2/2.1 I and knit in circular technique to R 8. Reset RC to 0. Set ndls for K2/P2 Rib. Begin incr on both sides every 20 Rs 1 St. 3 x for all sizes. Continue knitting in rib pattern to R 220 (240) [260]. Knit 1 R to the left at T 5.2/5.1. Transfer RB Sts to MB and BOLT.

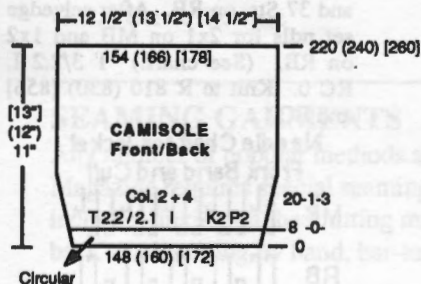

CAMISOLE STRAPS:

Make 1 and cut to use for both sides. With Col. 2 & Col. 4 together CO for FNR with 6 Sts on MB and 4 Sts. on RB. After selvedge at T 2.2/2.1 I knit to R 190 (200) [210] and BO.

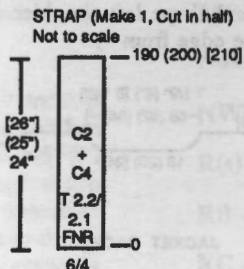

SKIRT FRONT:

With WY CO 114 (118) [122] Sts. After several rows, end with 1 R Ravel cord to the right. Change to Col. 1. T 4.1. RC 0. Knit to R 20. Pick up Sts. from first row to form hem. Reset RC to 0. T 4.1. Continue in St. St. and on the right incr. every 19 (20 [21] Rs 1 St. 5 x. At R 96 (100) [106] mark right side with a YM. Knit to R 118 (124) [130] and remove sts. on WY. Starting at ndl # (yellow) 76 (80) [84] to the left of -0-, CO with WY 54 (58) [62] Sts. Work the same as you did for the first section to R 118 (124) [130]. Fold 8 Sts. on right edge over to form doubled band for slit. With purl side facing, doubling the 8 sts. where the sections meet to form other slit the first 8 Sts. When both sections are rehung side by side, total # of sts. should be 152 (160) [168]. Continue in St. St. to R 238 (248) [260] and mark each side with a YM. Begin shaping sides decr. every 10 Rs 1 St. 5 x for all sizes. At R 288 (298) [310] SHR shaping EOR 9 Sts. 5 x. At R 298 (308) [320] remove on WY.

SKIRT BACK: With WY CO 152 (160) [168] Sts. After several rows, end with 1 row Ravel Cord to the right. Change to Col. 1. T 4.1. RC 0. Knit to R 20. Pick up Sts. from first row to form hem. Reset RC to 0. T 4.1. Knit in St. St. shaping sides incr. every 19 (20) [21] Rs 1 St. 5 x. At R 96 (100) [106] mark both sides with a YM. Continue in St. St. and complete same as skirt back.

WAISTBAND: Make 2.

With purl side facing rehang upper edge of skirt on 120 (128) [136] Sts. decreasing evenly across. Col. 1. T 4. RC 0. Knit to R 34. Pick up sts. from first row to form doubled waistband. Knit 1 R at T 10 and BOLT.

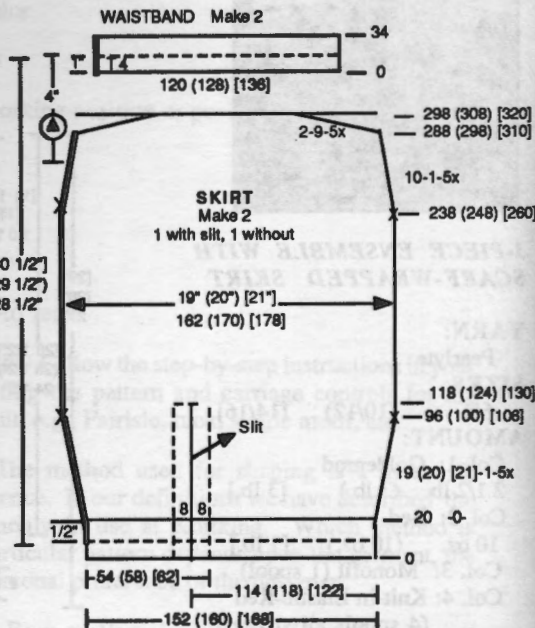

WRAP FOR SKIRT:

Section "A": With WY CO 50 Sts. After several rows end with 1 R Ravel Cord to the right. Change to Col. 1. T 4 (4.1) [4.2]. Knit in St. St. while shaping left side by incr. EOR 1 St. 130 (120) [110] x and every 3 Rs 1 St. 20 (30) [40] x, marking each side with a YM at rows 100, 200, and 300. At R 324 (336) [348]. Knit 1 R over all sts. at T 10 and BOLT.

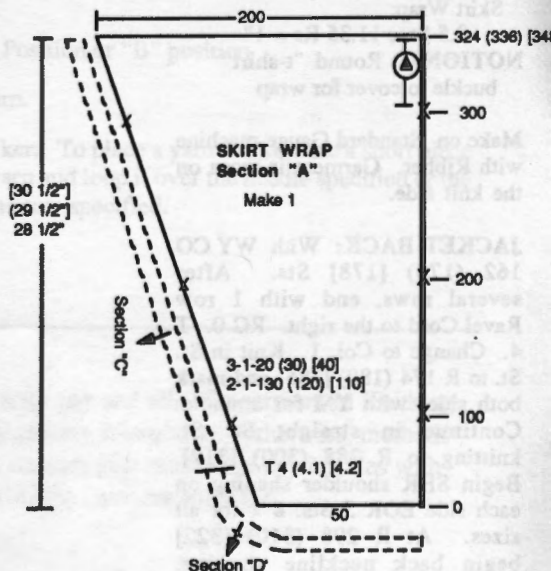

Section "B": With WY CO 50 Sts. After several rows, end with 1 row Ravel Cord to the right. Col. 1. T 4. RC 0. Knit to R 228 (250) [284] and begin SHR shaping right edge EOR 2 Sts. 21 x, every 4 Rs 2 Sts. 2x. At R 278 (300) [334]. Knit 1 R over all sts at T 10 and BOLT.

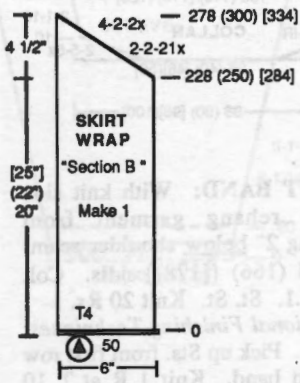

Section C & D Wrap Hems:
(See chart for placement.)
(C): With purl side facing

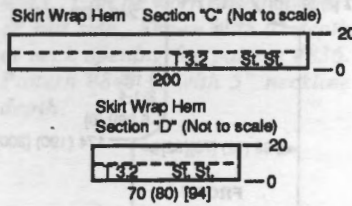

rehang long edge of skirt wrap on 200 ndls, working evenly down the wrap edge to cover approximately 33". Col. 1. T 3.2. St. St. RC 0. Knit to R 20. Pick up Sts. from first row to form hem. Knit 1 R across all Sts. at T 10 and BOLT.
(D): With remaining edge (including curve) rehang skirt wrap with purl side facing on 70 (80) [94] ndls. and knit this section same as "C".

Carefully weave sections C and D together to form smooth seam.

FINISHING:

For Jacket and Camisole:
Close jacket and camisole seams.
For Skirt and Wrap:
Seam the following skirt and wrap sections together placing them in the following layered order for seaming, machine symbols for sides shown on chart. With the waist side on the left.

1. Skirt Back - Knit side facing
 2. Sec. B - Knit side facing
 3. Sec. A-Wrap - Purl side facing
 4. Skirt Front - Purl side facing
- Layering these sections together and connecting either on machine, Lectrolink or by hand seaming. Carefully seam pieces together by hand at top (waistband).
Close other seams.
If desired top of skirt wrap can be whip stitched near skirt waistband across front to secure proper drape.

836



3-PIECE ENSEMBLE WITH WOVEN JACKET

YARN: Venetia, Pebble, Bright Filler, Sorbet

SIZES: 6/8 (10/12) [14] (18/20)

AMOUNT:

- Col. 1: Venetia Navy 2 1/2 lb. (3 lb) [3 lb] {3 lb}
- Col. 2: Pebble - Blue/Pink 1 lb. (1 1/4 lb) [1 1/2 lb] {2 lb}
- Col. 3: Bright Filler 4 oz. (5 oz.) [6 oz.] {8 oz.}
- Col. 4: Sorbet White 12 oz. (12 oz) [12 oz] {16 oz}

KIT PRICE:

Jacket & Skirt:
\$115.00 (128.00) [138.00] (155.00)

Tank Top:
\$18.00 [(\$18.00)] (\$24.00)

TENSION:

- Skirt: T 5.2
- Jacket: T 6
- Shell: T 6

GAUGE:

- Skirt: 8.46 Sts, 12.5 Rs = 1"
- Jacket: 6.36 Sts., 11 Rs = 1"
- Tank Top: 6.7 Sts., 13.69 Rs = 1"

NOTIONS: Elastic for skirt waistband.

Make on 24-St. Standard Punch Card or Electronic Machine.

JACKET BACK: With WY CO 132 (140) [148] {160} Sts. After several rows, end with 1 row Ravel Cord to the right. Change to Col. 1. RC 0. T 4.2. St. St. Knit to R 10. RC 0. Knit 10 Rs. Pick up sts. from first row to form hem. T 6. Weaving pattern following weaving chart. Knit to R 56 (60) [[64]] and begin side shaping. On each side decr. every 11 (12) [[13]] Rs. 1 St. 4 x. At R 104 (108) [[116]] begin incr side

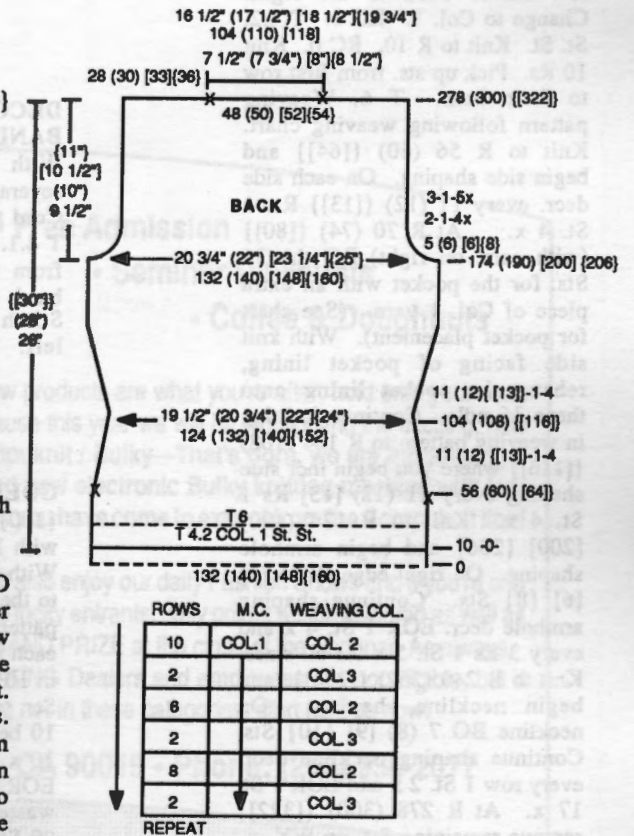

(continued from previous page)
 shaping every 11 (12) [13] Rs 1 St. 4 x. Knit to R 174 (190) [200] [206] and begin armhole shaping. On each side BO 5 (6) [6] [8] Sts. Continue shaping armhole decr. EOR 1 St. 4 x and every 3 Rs 1 St. 5 x for all sizes. Knit to R 278 (300) [322]. Mark center 48 (50) [52] [54] Sts. with a YM for neck opening and remove on WY.

POCKET LINING: Make 2 before beginning Jacket Front, as pocket lining will be worked into jacket front pieces. With Col. 1 'e' CO 38 Sts. RC 0. T 5. Knit to R 60. Remove on WY.

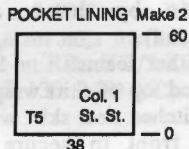

JACKET FRONT:

Make 1, Reverse 1.
 With WY CO 68 (72) [76] [82] Sts. After several rows end with 1 row Ravel Cord to the right. Change to Col. 1. RC 0. T 4.2. St. St. Knit to R 10. RC 0. Knit 10 Rs. Pick up sts. from first row to form hem. T 6. Weaving pattern following weaving chart. Knit to R 56 (60) [64] and begin side shaping. On each side decr. every 11 (12) [13] Rs 1 St. 4 x. At R 70 (74) [80] (with carr. on right) BO the 36 Sts. for the pocket with an extra piece of Col. 1 yarn. (See chart for pocket placement). With knit side facing of pocket lining, rehang the pocket lining onto these 36 ndls. Continue knitting in weaving pattern to R 104 (108) [116] where you begin incr side shaping every 11 (12) [13] Rs 1 St. 4 x. Knit to R 174 (190) [200] [206] and begin armhole shaping. On right edge BO 5 (6) [6] [8] Sts. Continue shaping armhole decr. EOR 1 St. 4 x and every 3 Rs 1 St. 5 x for all sizes. Knit to R 240 (262) [284] and begin neckline shaping. On neckline BO 7 (8) [9] [10] Sts. Continue shaping neckline decr. every row 1 St. 2 x and EOR 1 St. 17 x. At R 278 (300) [322] remove remaining Sts. on WY.

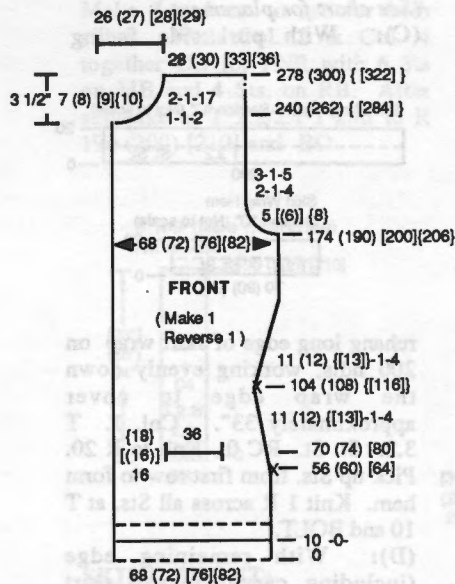

POCKET BAND: Make 2. With knit side facing pick up the 36 Sts. from the opening of jacket front. Col. 1. T 4.1. St. St. Knit to R 20. Pick up Sts. from first row to form doubled band. Rehang loose edge of pocket lining onto same ndls. Knit 1 R at T 10 across all Sts. and BOLT.

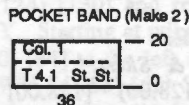

DECORATIVE POCKET BAND:

Located on Jacket Front With WY CO 30 Sts. After several rows end with 1 row Ravel Cord to the right. Col. 1. RC 0. T 4.1. Knit to R 20. Pick up Sts from first row to form doubled band. Knit 1 R at T 10 and BOLT. Stitch on to jacket upper front left.

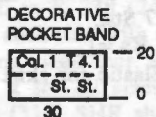

COLLAR: WY CO 86 (90) [96] [100] Sts. After several rows end with 1 row Ravel Cord to the left. With Col. 1. Tension 6, knit 1 R to the right. RC to 0. In weaving pattern begin knitting by SHR on each side. Place 25 Sts. each side in HP. Shape SHR EOR return 5 Sts. to WP 5 x for all sizes. At R 10 begin incr. shaping EOR 1 St. 10 x for all sizes. At R 30 decr. EOR 1 St. 8 x for all sizes. With waste rag (any swatch piece) add 29 Sts. of each side. With Col. 1

only at T 4.1 knit in St. St. over all sts. to R 66. Pick up Sts. from R 46 to form double band. Knit 1 R at T 10 and BOLT.

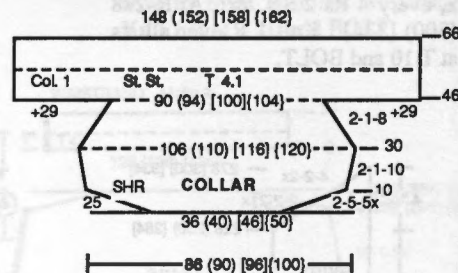

FRONT BAND: With knit side facing rehang garment front (starting 2" below shoulder seam) on 154 (166) [178] ndls. Col. 1. T 4.1. St. St. Knit 20 Rs.

Optional Finishing Techniques:

1. Pick up Sts. from first row to form band. Knit 1 R at T 10 and BOLT. OR ...
2. Remove sts on WY and fold in half to weave hem.

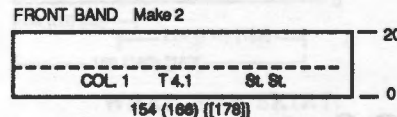

SLEEVE BAND TRIM: Close shoulder (front/back). With knit side facing rehang sts. around armhole line on 166 (174) [182] [190] ndls. RC 0. Col. 1. T 4.1. Knit to R 20. Pick up Sts. from first row to form double band. Manually knit 1 R to the left for loose tension and BOLT.

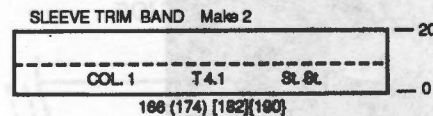

JACKET SLEEVE: With WY CO 52 (60) [68] [72] Sts. After several rows, end with 1 row Ravel Cord to the right. Change to Col. 1. RC 0. T 4.1. St. St. Knit to R 20. Pick up sts. from first row to form hem. Reset RC to 0. T 6. Continue knitting in weaving pattern (see chart) while shaping sides of sleeve by incr. every 6 Rs 1 St. 14 (20) [26] [0] x, and every 5 Rs 1 St. 16 (10) [4] [34] x. At R 164 (170) [176] begin sleeve cap shaping. On each side BO 5 (6) [6] [8] Sts.

Continue shaping sleeve cap by decr. EOR 1 St. 5 x and every 4 Rs 1 St. 13x. At R 228 (234) {[240]} knit last row at T 10 and BOLT.

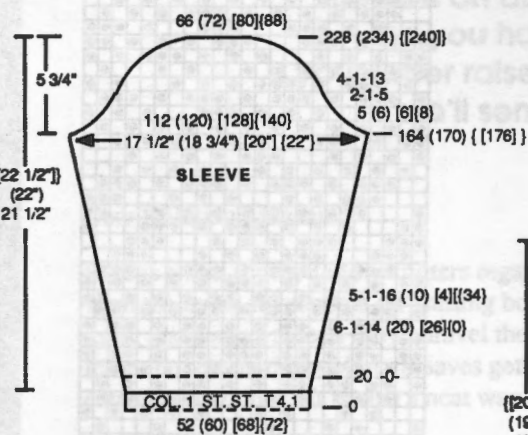

TANK TOP:

Note: This pattern is shown this issue with Garment #836 and #843. Can be worn on either purl or knit side. Shown with 6" depth at neck opening for pattern #836. Pattern #843 is with 5" neckline depth.

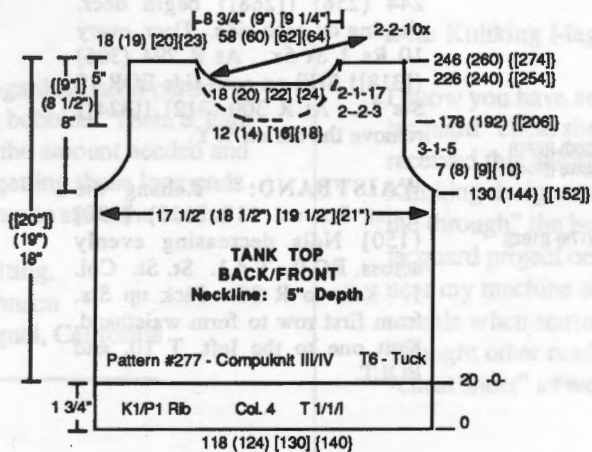

TANK TOP BACK: With Col. 4 CO 118 (124) [130] [140] Sts. for K1/P1 Rib. After selvedge RC 0. T 1/1/ I. Knit to R 20. Transfer RB Sts. to MB. Reset RC to 0. T 6. Pattern #277 in Compuknit III/IV. Knit in Tuck Pattern to R 130 (144) {[152]} and begin armhole shaping. On each side BO 7 (8) [9] [10] Sts. Continue shaping, decr. every 3 Rs 1 St. 5 x for all sizes. Knit to

Tank Top Tuck Pattern



Compuknit #277

(continued next page)

WELCOME

Seminar & Open House • October 16-20, 1990

Join us! Our famous Seminar and Open House runs from Tuesday, October 16th through Saturday, the 20th, and will be held, as always, at KNITKING 1128 Crenshaw Blvd., Los Angeles, CA 90019.

Come and meet our experts along with many acknowledged guest authorities. Every year there are new guests and new products, and this year is no exception! This year's Seminar will feature renowned Industry experts Jan Wold and Jan Mills, Jill Stern, Sandee Cherry and Gloria Saunders, as well as KNITKING's own staff of knowledgeable designers.

KNITKING • 1128 Crenshaw Boulevard • Los Angeles, CA 90019 • Phone: (213) 938-2077

- Free Admission
- Seminar Discounts
- Coffee & Doughnuts

If new products are what you're after, hold onto your seat, because this year we will be highlighting the exciting, new **Compuknit / Bulky**—That's right, we are introducing a brand new electronic Bulky knitting machine with features you have come to expect from the Compuknit line!

You'll also enjoy our daily Fashion Shows and if you're one of the lucky entrants, daily prizes will be awarded as well as a GRAND PRIZE at the close of the Seminar. As always, KNITKING Dealers and employees are not eligible, but if you're not in these categories, start knitting now!

(continued from previous page)

R 226 (240) {[254]}. Note pattern row and ndl position. Begin neckline shaping. BO center 18 (20) [22] [24] Sts. *On neckline BO EOR 2 Sts. 10 x. At R 246 (260) {[274]} remove shoulder Sts. on WY. Reset RC to 226 (240) {[254]} and shape neckline from *, reversing shapings.

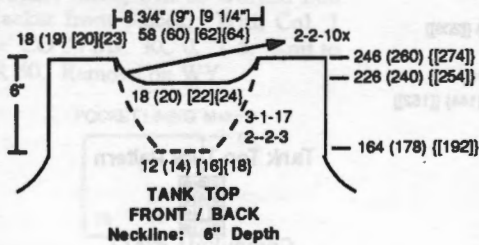

TANK TOP FRONT: Knit same as back up to instructions below for either 5" neckline or 6" neckline as desired.

For 5" depth on neckline, knit to R 178 (192) {[206]} and begin neckline shaping: Note pattern row and ndl position. BO center 12 (14) [16] [18] Sts. Place all Sts. to the left in HP. *On neckline BO EOR 2 St. 3 x, and EOR 1 St. 17 x. Knit straight in tuck pattern to R 246 (260) {[274]} and remove shoulder sts. to WY. Reset RC 178 (192) {[206]} and complete neckline from *, reversing shapings.

For 6" depth on neckline, knit to R 164 (178) {[192]} and begin neckline shaping: Note pattern row and ndl position. BO center 12 (14) [16] [18] Sts. Place all Sts. to the left in HP. *On neckline BO EOR 2 St. 3 x, and every 3 Rs 1 St. 17 x. Knit straight in pattern to R 246 (260) {[274]} and remove shoulder sts. to WY. Reset RC to 164 (178) {[192]} and complete neckline from *, reversing shapings.

SKIRT: Make two, front and back are the same. WY CO 170 (178) [186] [198] Sts. After several Rs, end with 1 row Ravel Cord to the left. RC 0. T 4. St. St. Col. 1. Knit to R 20. Pick up Sts. from first row to form hem. RC 0. T 5.2. Begin SHR shaping on each side. SHR EOR 18 Sts 3x. Continue knitting in St. St. to R 100. Place a YM on each side to aid in seaming. At R 244 (256) {[268]} begin decr. shaping on each side. Decr. every 10 Rs 1 St 5x. At R 294 (306) {[318]} SHR on each side EOR 10 Sts 3x. At R 300 (312) {[324]} remove the Sts on WY.

WAISTBAND: Rehang the waist Sts on 110 (120) [130] [150] Ndl's decreasing evenly across. RC 0. T 4.1. St. St. Col. 1. Knit to R 30. Pick up Sts. from first row to form waistband. Knit one to the left, T 10, and BOLT.

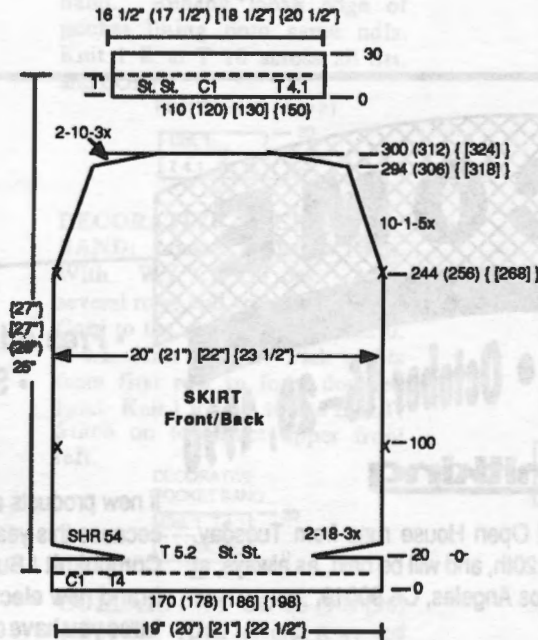

FINISHING: Close all seams. **Tank Top:** With 2 strands of Col. 4 single crochet 1 time around neckline and armhole. **Jacket:**
 1. Attach front bands.
 2. Steam collar and trim. Carefully mold trim around collar to base and whip stitch.

Garment #836 - Weaving Pattern
24 Sts. x 100 Rows

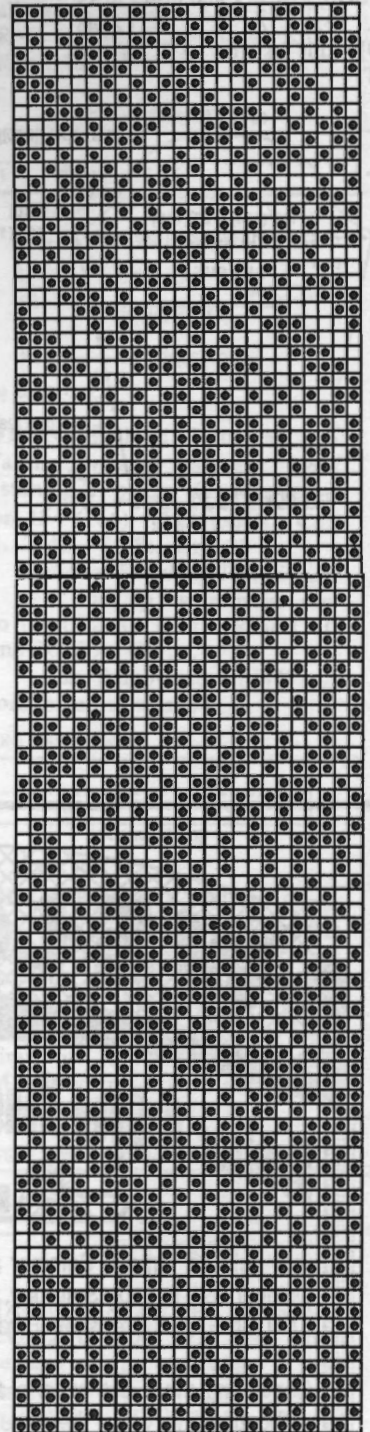

3. Attach collar to jacket with knit side of collar and jacket together. With front band overlapping on purl side, carefully attach trims for approximate 1/2" overlap to create a lapel. Fold to wear with knit side showing where trims meet for lapel.

HINTS FROM READERS

Are you an absolute beginner or an experienced knitter?
Do you have a funny story to tell or a tale of woe?
If your letter raises a smile or helps out another machine knitter,
we'll send you a \$10.00 reward if it's published.

Dear Knitking Magazine,

Here is a hint for my fellow knitters regarding ravel cords. I wind the nylon ravel cords on knitting bobbins. Then, if I am using just a short piece I only unravel the amount needed and leave the rest on the bobbin. It saves getting those long ends entangled in things. It is also a neat way to store the cords.

Happy Knitting,
Beverly Johnson
Laguna Niguel, California

Dear Knitking,

I find that when using my Garter Carriage the swatch will knit perfectly, but when I start on the body of the garment, which is usually much wider, it may drop stitches on one side or the other. I have found that in most cases if I move my cone of yarn just slightly toward the side where the dropped stitches are appearing, the problem can be eliminated. This simple movement has helped many times and saved me lots of time in picking up stitches and wrongly placing the blame on the yarn content or the machine itself!!

Hope this helps others with their Garter Carriage knitting!

Sandra Smithers
New York, New York

Dear Knitking:

A long time ago a friend gave me a hint which I would like to pass on to my fellow knitters. When knitting on the main bed and working on a pattern that requires lots of increasing or decreasing shaping, I use my Ribber as a counter. This is especially helpful when the shaping on each side is different. On each side I push up (about 1 inch) the same number of Ribber needles as the shaping requires. Then each time I shape, I push a Ribber needle down. You can see at a glance how far you have gone with your shaping. Hope this will help others.

Joan Dee
Pittsburgh, Pennsylvania

Dear Knitking Magazine:

I know you have seen this simplified double jacquard "cheat sheet" instructions before. I received this helpful guide from one of the Knitking designers who was kind enough to "talk me through" the beginning of my first double jacquard project on my Compuknit IV. I keep it near my machine so that I can keep myself out of trouble when starting a double knit project. Thought other readers might benefit from this "cheat sheet" as well.

1. CO for FNR and knit selvedge.

Set Compuknit IV pattern, and #7 (RCC).

2. T 2/2 I. Pass carr from right to left, knitting 1 row plain. Set KCI and knit 1 row to set needles for pattern. Depress both part buttons. Knit 1 R to left.
3. Change to garment tension and 2nd color. Knit 2 rows.
4. Every 2 rows change colors, knit number of rows needed for pattern.
5. Transfer stitches from Ribber Bed to Main Bed
6. Change to T 10. Knit 1 row. Bind off.

Charlene Parmlee
Milington, Tennessee

Dear Charlene:

Glad we could help you. We've handed out this "cheat sheet" many times and it seems to be a real aid for beginning double knitters. Thanks for reminding us to share this hint!



TWO-COLOR DRESS

YARN: Venetia

SIZES:

6/8 (10/12) [14]

AMOUNT:

Col. 1: Fisherman

1 cone all sizes
(cones approx 1 1/2 lb. each)

Col. 2: Navy

1/2 lb. all sizes

KIT PRICE: \$52.00

TENSION:

Body: T 4.1; Hem: T4

GAUGE:

17.6 Sts, 24.66 Rs = 2" (5 cm.)

NOTIONS: 1 - 1" button

Make on Standard Gauge Machine.

BACK: With WY CO 160 (168) [176] Sts. After several rows, end with 1 row Ravel Cord to the right. Change to Col. 1. RC 0. T 4.1. St. St. SHR shaping on lower edge both sides EOR 20 Sts. 3x. After SHR, reset RC to 0. Knit shaping both sides by incr every 10 Rs 1 St 7x for all sizes. Continue to R 100 and on each side place a YM for aid in seaming. Knit to R 228 (240) [246] and place a YM on each side. Begin decr. shaping on both sides every 10 Rs 1 St. 6 x (all sizes). At R 288 (300) [306] place a YM each side and begin incr. shaping on each side every 20 Rs 1 St 4 x (all sizes). At R 392 (410) [416] begin armhole shaping. On each side BO 8 (9) [10] Sts. Continue armhole shaping decr. EOR 1 St. 13 x for all sizes. At row 494 (518) [530] begin SHR shoulder shaping EOR 7 Sts. 5 x, and EOR 3 (4) [6] Sts. 1 x. At R 500 (524) [536] begin shaping neckline. Place center 16 (20) [22] Sts. in HP and all Sts. to the left. *Shape neckline

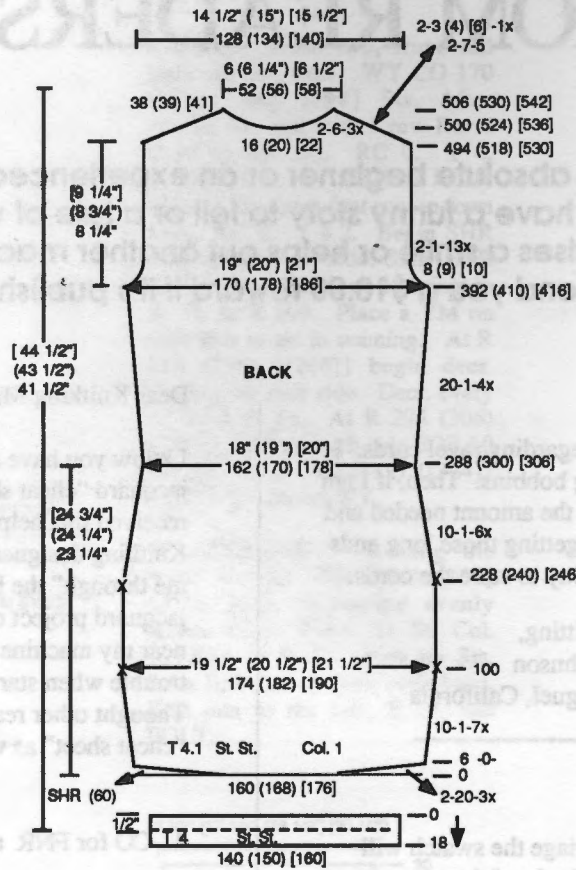

SHR EOR 6 St. 3x. At R 506 (530) [542] BO shoulder Sts. Return left side to WP (except for center sts) and shape neckline from *, reversing shaping. Remove center neckline Sts. on WY.

BACK HEM: With purl side facing rehang lower edge of back onto 140 (150) [160] Sts., decr. evenly across. T 4. RC 0. St. St. Knit to R 18. Pick up Sts. from first row to form hem. Knit 1 R at T 10 and BOLT.

FRONT:

Part 1: Lower Section

With Col. 1. knit same as back up to R 228 (240) [246] and place a YM on each side. Begin decr side shaping. **Right side:** Decr. every 10 Rs 1 St. 1 x all sizes; Begin SHR shaping at R 238 (252) [256] EOR by placing 4 Sts. in HP 41 (43) [45] x.

(Remember to wrap inside ndl to avoid hole.) **Left side:** Incr. every 10 Rs 1 St. 5x. At R 288 (300) [306] place a YM on left side and begin incr. shaping every 20 Rs 1 St 2 x all sizes. At R 322 (340) [348] knit 1 R over all sts. at T 10 and BOLT. **Front Hem:** Same as Back Hem.

Part 2: Middle Section

With WY CO 164 (172) [180] Sts. After several inches of WY, end with 1 R Ravel Cord to the right. Change to Col. 2. T 4.1. Set RC at 238 (252) [256]. Begin decr shaping on right edge every 10 Rs 1 St. 5x while working SHR increases EOR 4 St. 41 (43) [45] x. Remember to mark right edge with YM at R 288 (300) [306] and on right edge begin right side incr. shaping every 20 Rs 1 St. 4x. On left edge, at R 322 (340) [348] begin decr. shaping every row 1 St. 43 (46) [50]x and EOR 1 St. 39 x (all sizes), marking left edge with a YM for neckline at R 444 (464) [476]. Continue left side decr shaping EOR 1 St. 24 (25) [26] x and every 3 Rs 1 St. 2x. On right, at R 392 (410) [416] begin shaping armhole BO 8 (9) [10] Sts. Continue armhole shaping decr. EOR 1 St. 13 x. R 490 (514) [526] begin SHR shaping the same as back shoulder and BO shoulder Sts. at R 502 (526) [538].

Part Three: Upper Section

With WY CO 82 (85) [89] Sts. After several inches, end with 1 R Ravel Cord to the right. Change to Col. 1. T 4.1. Set RC at 322 (340) [348]. Place all ndls in HP. On right edge begin SHR incr. to WP every row 1 St. 43 (46) [50] x and EOR 1 St. 39 x (all sizes). On left edge incr. every 20 Rs. 1 St. 3 x. At R 392 (410) [416] begin armhole shaping. BO 8 (9) [10] Sts. Continue decr. EOR 1 St. 13x all sizes. Knit to R 444 (464) [476] and on right edge begin neckline shaping decr. EOR 1 St. 24 (25) [26] x, and every 3 Rs 1 St. 2x. On left edge: Continue knitting straight to R 490 (514) [526] where SHR shaping begins. SHR shoulder same as back. At R 502 (526) [538] BO shoulder Sts.

(continued next page)

(continued from previous page)

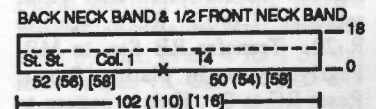
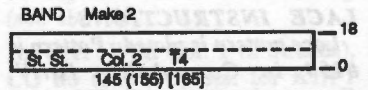
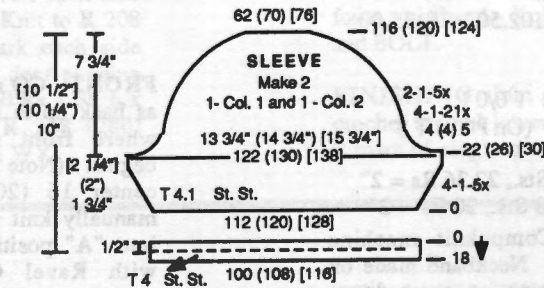
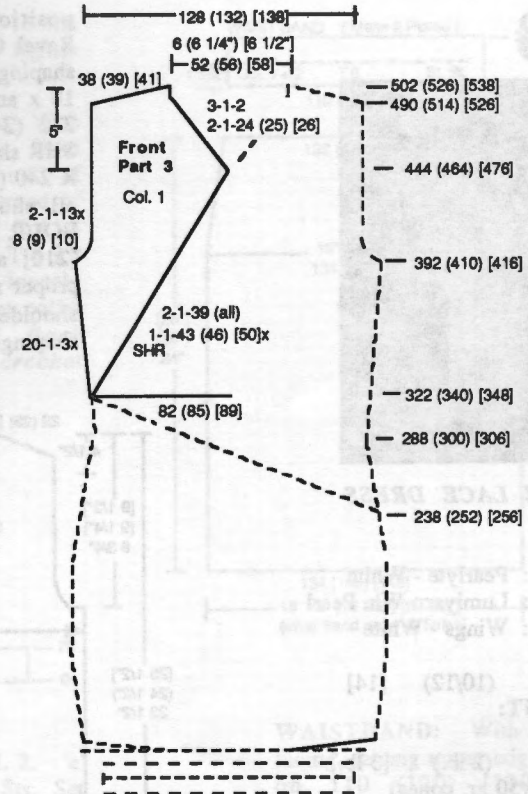
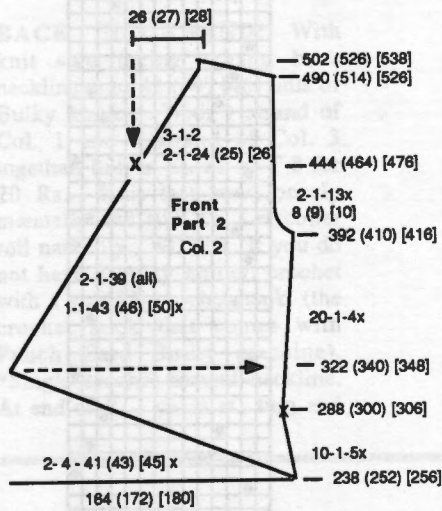
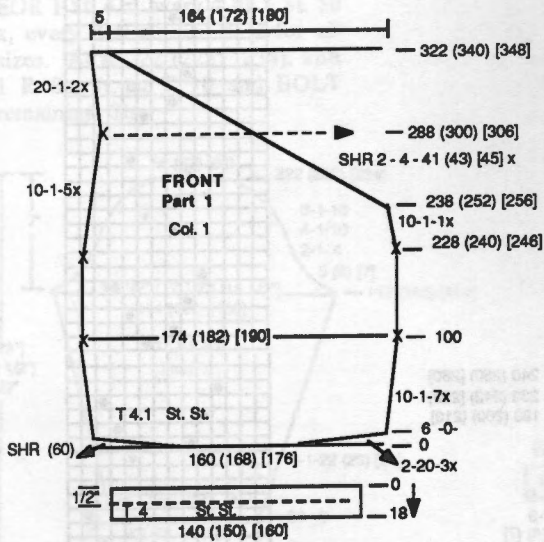

SLEEVE: Make 2. 1 - Col. 1, and 1 - Col. 2.
With WY CO 112 (120) [128] Sts. After several rows, end with 1 row Ravel Cord to the right. RC 0. T 4.1. Change to Col. 1 or 2. St. St. and begin incr. on both sides every 4 Rs 1 St. 5 x (all sizes). At R 22 (26) [30] begin arm cap shaping. On each side BO 4 (4) [5] Sts. Continue decr. every 4 Rs 1 St. 21 x and EOR 1 St. 5 x (all sizes). At R 116 (122) [124] knit the last R at T 10 and BOLT remaining Sts.

SLEEVE BAND: With purl side facing rehang lower edge of sleeve onto 100 (108) [116] nds. With matching color, RC 0. T 4. St. St. Knit to R 18. Pick up Sts from first row to form band. Knit 1 R at T 10 and BOLT.

TRIM BAND: Make 2.
With purl side facing, pick up open sts. from lower edge of Front (Part 2) and hang onto 145 (155) [165] nds, picking up bar between Sts. to fill open spaces. With Col. 2 at T 4, knit 18 Rs. Pick up Sts from first row to form doubled band. Knit 1 R at T 10 and BO.
Repeat for second band picking up upper edge of Front (Part 2).

NECKBAND:
Make 1 in Col. 1.
After seaming shoulder of Front Part 3 and Back, rehang with purl side facing onto 102 (110) [116] nds. With Col. 1, T 4, knit 18 Rs. Pick up Sts. from first R to form doubled neckband. Knit 1 R at T 10 and BOLT.

FINISHING: Join seams. Whip stitch Part 1 to Part 2 at the BO edge allowing the trim band to fold over. Complete upper edge-Part 2 to Part 3.



2-PIECE LACE DRESS

YARN:

- Col. 1: Pearlyte - White
- Col. 2: Lumiyarn-Wh. Pearl
- Col. 3: Wings - White

SIZES:

6/8 (10/12) [14]

AMOUNT:

- Col. 1: 2 lb. (2 lb.) [3 lb.]
- Col. 2: (50 gr. cones) 6 cones (8 cones) [10 cones]
- Col. 3: 2 oz. all sizes

KIT PRICE:

\$90.00 \$102.50 \$135.00

TENSION:

- Lace: T 6
- K1/P1 Rib: T 0/0 I
- Neckband: (On PCB) T 8

GAUGE:

- Lace: 14 Sts., 22.36 Rs = 2"
- Rib: 18.58 Sts., 20 Rs = 2"

Make on Compuknit machine with Ribber. Neckband made on Bulky Machine or same loose look can be created with hand crochet pattern.

LACE INSTRUCTIONS:

Lace pattern is plated. Pattern is #154 in Compuknit III/IV. Garment is worn on the knit side.

BACK: With Col. 1 and Col. 2 together CO for K1/P1 Rib. After selvedge, T 0/0 I. RC 0. Knit to R 20. Transfer RB Sts. to MB. Pearlyte yarn in plating finger. Reset RC to 0. Knit in pattern to R 132 (138) [142] and begin armhole shaping. ON EACH SIDE BO 5 (6) [7] Sts. Continue armhole shaping by decr. every row 1 st. 3 x and EOR 1 st. 5x for all sizes. At R 190 (200) [210] begin back neckline shaping. (Note pattern row). BO center 16 (20) [24] Sts. Manually knit all sts. to the left back to "A"

22

position (non-working) with Ravel Cord. *Continue neckline shaping by Decr. every row 1 St. 10 x and EOR 1 St. 15 x. At R 232 (242) [252] begin shoulder SHR shaping EOR 3 Sts. 4 x. At R 240 (250) [260] knit 1 R across all shoulder Sts. at T 10 and BOLT. Reset RC to R 190 (200) [210] and lace pattern back to proper row. Return out of work shoulder sts. to WP and reverse shapings from *.

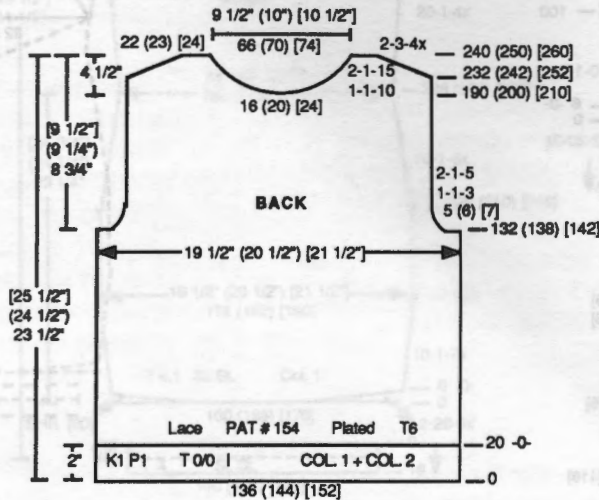

FRONT: CO and knit front same as back up to R 172 (178) [184] where front neckline shaping begins. (Note pattern row.) BO center 16 (20) [24] Sts. and manually knit all Sts. to the left into "A" position (non-working) with Ravel Cord. *Continue shaping neckline by decr. every row 1 St. 10 x and EOR 1 st. 15 x. Continue knitting straight in pattern to R 232 (242) [252] where shoulder SHR shaping begins same as back. At R 240 (250) [260] knit 1 R across all shoulder sts. at T 10 and BOLT. Reset RC to 172 (178) [184] and return to proper row in lace pattern. Return out of work shoulder sts. to WP and reverse shapings from *.

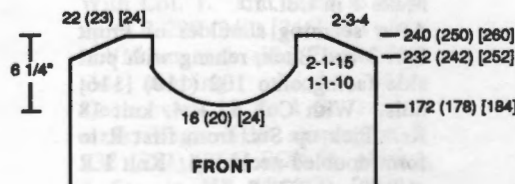

Lace Pattern
14 Sts. x 100 Rows

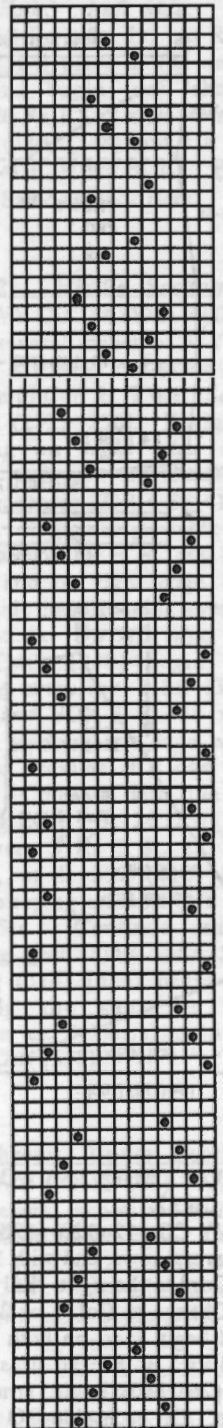

SLEEVE: With Col. 1 and Col. 2 together CO for K1/P1 Rib 68 (74) [80] sts. After selvedge, T 0/0 I. RC to 0. Knit to R 20. Reset RC to 0. Transfer RB Sts. to MB and set yarns for plating in lace pattern. Incr. 1 St. each side. Knit in pattern while shaping sleeve by incr. every 6 Rs. 1 St. 22 (23) [24] x. At R 142 (148) [154] begin sleeve cap shaping. ON EACH SIDE BO 5 (6) [7] Sts. Continue shaping cap by decr. (continued next page)

(continued from previous page)

EOR 1 St. 4 x, every 4 Rs 1 St. 10 x, every 3 Rs 1 St. 10 x for all sizes. At R 222 (228) [234], knit 1 R St. St. at T 10 and BOLT remaining Sts.

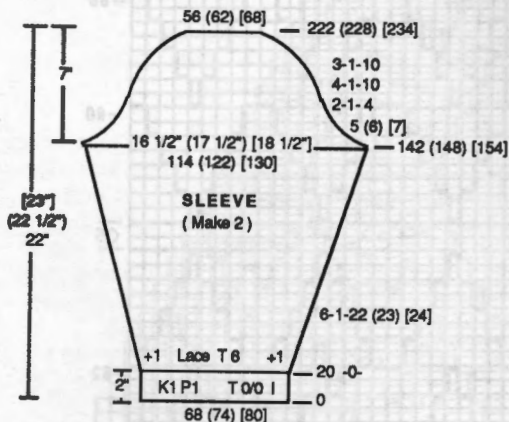

BACK NECKBAND: With knit side facing rehang back neckline onto 42 (44) [46] ndls of Bulky knitter. With 1 strand of Col. 1 and 1 strand of Col. 3 together, knit in St. St. at T 8 for 20 Rs. Knit last row loosely manually and BOLT. Let collar roll naturally. **NOTE:** If you do not have a bulky knitter, crochet with a size 8/0 crochet hook, (the crochet hook that comes with Punch Card Bulky machine). *Single crochet around neckline. At end of R, 1 chain st., turn and

repeat from * for total of 16 Rs. Crochet final row slightly tighter so that edge will roll.

FRONT NECKBAND: With knit side facing rehang front neckline on 56 (60) [64] ndls of Bulky knitter. With 1 strand of Col. 1 and 1 strand of Col. 3 together, knit in St. St. at T 8 for 20 Rs. Knit last row loosely manually and BOLT. Let collar roll naturally. (see *Back Neckband for hand crochet method*).

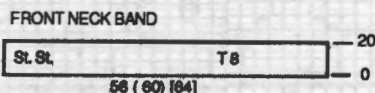
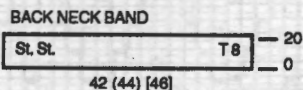

SKIRT: Col. 1 and Col. 2. 'e' wrap CO 134 (140) [146] Sts. Set RC to 0. Knit in plated lace pattern, at T 6 to R 100 (all sizes). Place a YM on each side for aid in seaming. Knit to R 208 (220) [232] and mark each side with a YM. Begin decr shaping on each side every 10 Rs 1 St. 6 x for all sizes. At R 268 (280) [292] remove sts. on WY.

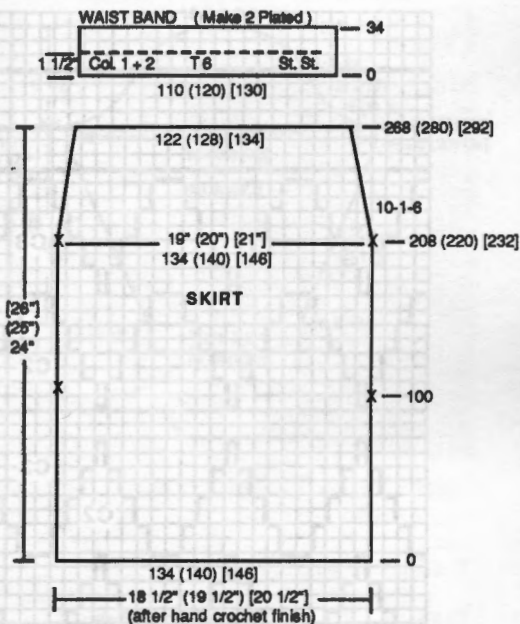

WAISTBAND: With purl side facing, rehang upper edge of skirt on 110 (120) [130] ndls, decreasing evenly across. T 6. Plated. RC 0. St. St. Knit to R 34. Pick up sts. from first row to form waistband. Knit 1 R at T 10 and BOLT.

FINISHING: Join seams. Hand crochet around lower hem of skirt 2 rows of single crochet.

839



WOMENS SOUTHWEST INTARSIA PULLOVER

YARN: Softon (2strands throughout)

SIZES: Small (Med) [Large]

AMOUNT:

Col. 1: Black
6 oz. (7 oz.) [8 oz.]

Col. 2: Purple
3 oz. (4 oz.) [5 oz.]

Col. 3: Cottage Rose
5 oz. (6 oz.) [7 oz.]

Col. 4: Goldenrod
4 oz. (5 oz.) [6 oz.]

Col. 5: Aqua
3 oz. (3 oz.) [4 oz.]

KIT PRICE:

\$30.00 (33.50) [\$40.50]
(includes beads)

TENSION:

Intarsia: T 6
K-Carr St. St. : T 5.2
Rib: T 1/1 I

GAUGE:

4.28 Sts., 6 Rs = 1"

Make on Punch Card Bulky knitter with Intarsia capability with Ribber.

Note: For solid rows of color between intarsia designs, you can

continue using Intarsia technique or switch to K-Carr. for these sections. If so, Tension should be adjusted for K-Carr knitting (see above).

BACK: With Col. 1 (2 Strands), CO 80 (84) [90] Sts. for K1/P1 Rib. After selvedge RC 0. T 1/1 I. Knit to R 8. Transfer RB Sts. to MB. RC 0. K-Carr. T 5.2. Begin knitting following pattern instructions below and shaping sides by incr. every 4 Rs 1 St. 4x. Knit stripes (K-Carr, T 5.2) and intarsia (Intarsia Carr., T 6) following intarsia chart. At R 50 (56) [62] shape armhole. On each side BO 4 (5) [6] Sts. Decr. EOR 1 St. 3 x for all sizes. Continue in intarsia to R 92 (100) [110]. Shape SHR shoulders EOR 6 Sts. 3 x for all sizes. At R 98 (106) [116] pick up 1 St. on each side of center 30 (32) [34] Sts. for neckband. With K-Carr at T 5.2

Garment #839 Womens Southwest Intarsia - Body

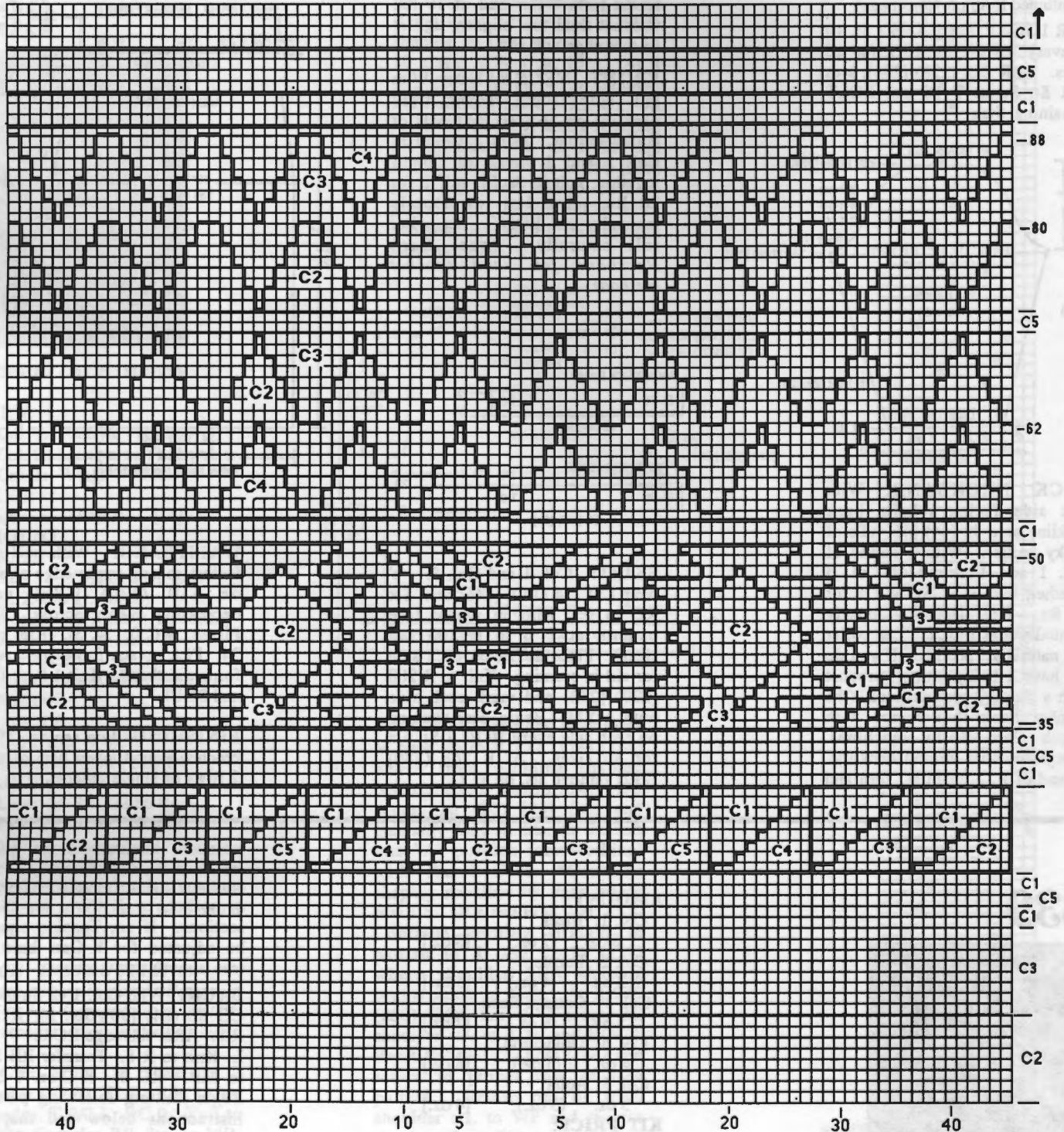

knit 7 Rs. Knit 1 R at T 10 and BOLT.

FRONT: Knit front same as back up to R 84 (92) [102]. Shape neckline. Place center 14 (16) [18] Sts. in HP and all Sts. to the left. *Shape neck with SHR every row 1 St. 8 x all sizes. At R 92 (100) [110] SHR shoulder same as back. At R 98 (106) [116] remove shoulder sts. on WY. Reset RC to 84 (92) [102] and 24

shape neckline from *, reversing shapings. Incr. neck Sts. to 42 (44) [46] by picking up Sts from side of neckline straight knitting. With K-Carr at T 5.2 knit 7 Rs. Knit 1 R at T 10 and BOLT.

SLEEVE:

With Col. 1 CO 54 (54) [60] Sts. for K1/P1 Rib. After selvedge RC 0. T 0.2/0.2 I. Knit to R 8. Transfer RB Sts. to MB. Knit stripe and intarsia at tensions

above. RC 0. Shape sides of sleeves while knitting in pattern and following intarsia chart. Incr. on each side every 5 Rs 1 St. 5x (every 5 Rs 1 St. 6 x) [every 6 Rs 1 St. 5 x]. At R 26 (30) [34] shape sleeve cap. On each side BO 5 (5) [6] Sts. Decr. EOR 1 St. 17 x, every row 1 St. 4 x all sizes. Knit to R 80 (84) [88], knitting last R at T 10 and BOLT remaining Sts.

(continued next page)

(continued from previous page)

Womens Southwest Intarsia
Garment #839 - Sleeve

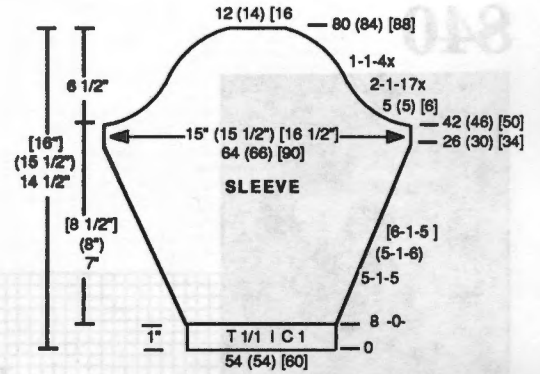
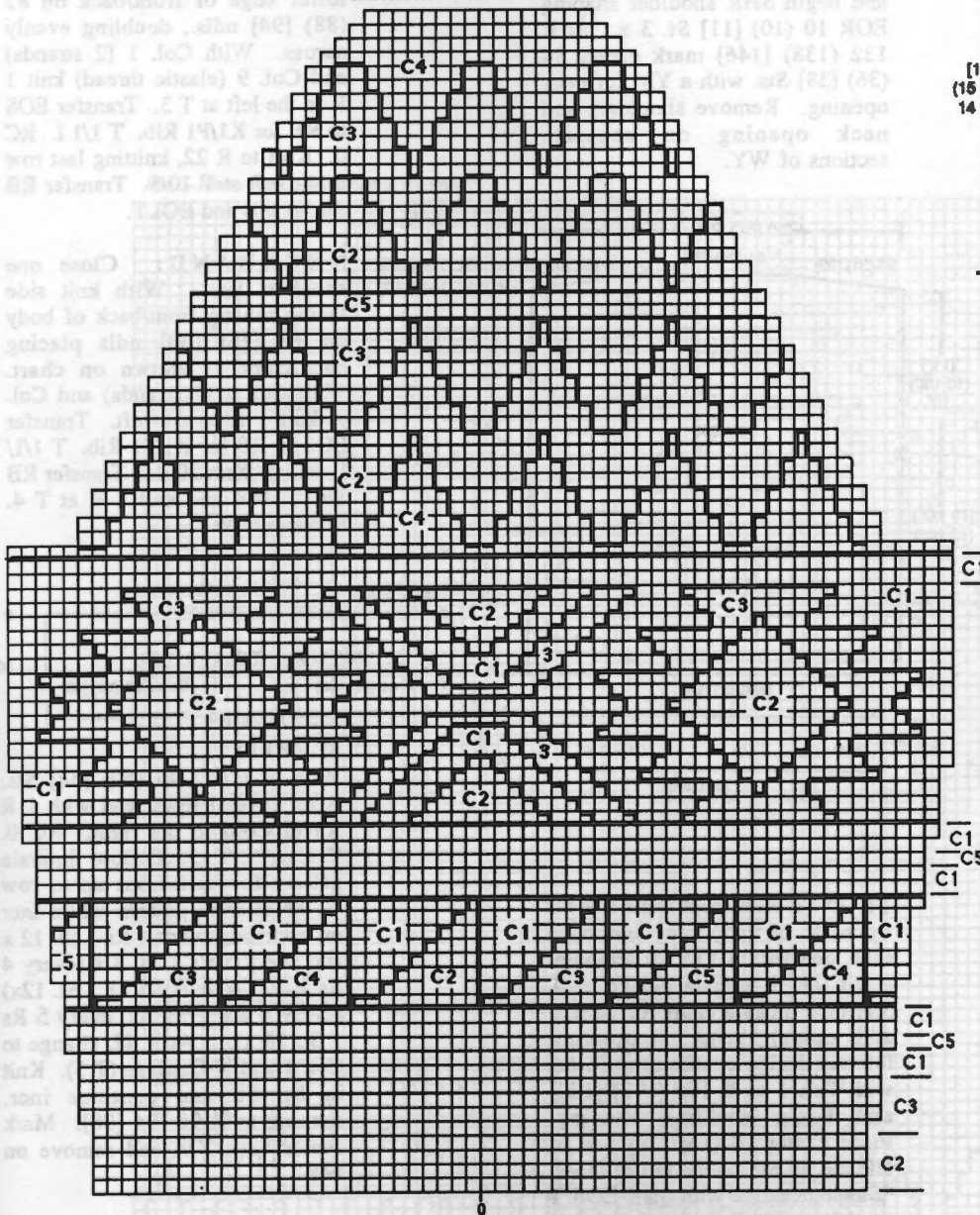

BACK NECK BAND

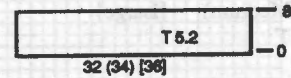

FRONT NECK BAND

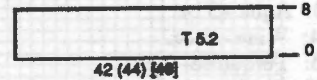

Bead Lattice Example

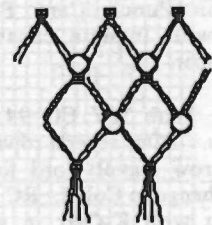

FINISHING: Close all seams. Attach beads and tassels as follows:

Cut 2 strands 16" using Col. 1. With latch tool in center of 16", hood as in a latch hook rug every 4th St. of R 20. Strands should be double, making 4 strands. Divide total into 2 sections each. Gather each adjoining section in between top 4 Sts. Place bead on all and knot. Divide in half and repeat placement for lattice effect. Work two full rows with beads. Last row knot yarn only. Trim even to lower edge of sweater.



MENS SOUTHWEST INTARSIA PULLOVER

YARN: Softon
(2 strands throughout)
SIZES:
Small (Medium) [Large]
AMOUNT:

- Col. 1:**
Dusty Blue - 2 lb all sizes
Col. 2: Black - 2 oz.
Col. 3: Aqua - 3 oz.
Col. 4: Wine - 3 oz.
Col. 5: Turquoise - 2 oz.
Col. 6: Goldenrod - 2 oz.
Col. 7: Rose - 2 oz.
Col. 8: Purple - 2 oz.
Col. 9: Knit-in Elastic
Silver - 1 spool

KIT PRICE: \$58.00

TENSION:

- Intarsia: T5.1
K-Carriage: T5

GAUGE: 4.28 Sts, 5.71 Rs = 1"

Make on Punch Card Bulky knitter with Intarsia capability with Ribber.

BACK: With WY CO 94 (98) [104] Sts. After several rows end with 1 row Ravel Cord to the right. Change to Col. 1. RC 0. T 5. Knit with K-Carr in stripe pattern as follows:

- Col. 1: 2 rows
- Col. 2: 2 rows
- Col. 3: 4 rows
- Col. 4: 2 rows
- Col. 1: 4 rows

Begin intarsia pattern at T 5.1 on following row (see chart for design and color selection). Knit to R 30 and begin stripe pattern with K-Carr at T5 as follows:

- Col. 1: 4 rows
- Col. 4: 2 rows
- Col. 3: 4 rows
- Col. 2: 2 rows

At R 42 change to Col. 1 and knit to R 68 (72) [76]. Mark each side

with YM for armhole. Continue in St. St. to R 126 (132) [140] and begin SHR shoulder shaping EOR 10 (10) [11] St. 3 x. At R 132 (138) [146] mark center 34 (36) [38] Sts. with a YM for neck opening. Remove shoulders and neck opening on separate sections of WY.

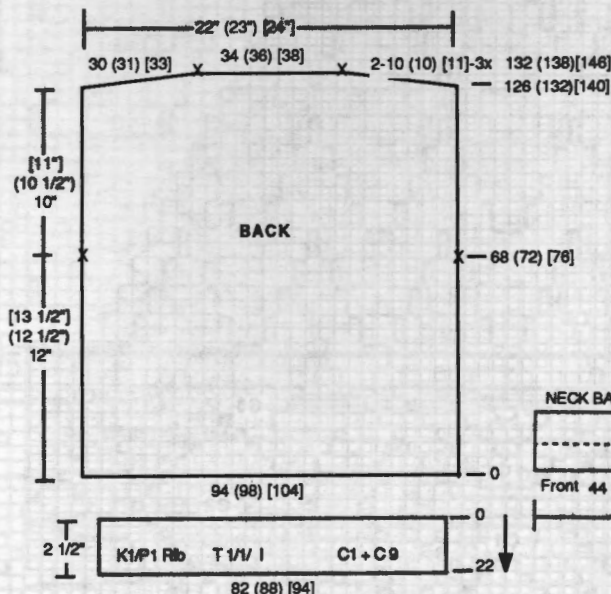

WAISTBAND: Make 2.

With purl side facing rehang lower edge of front/back on 82 (88) [94] ndls., doubling evenly across. With Col. 1 (2 strands) and Col. 9 (elastic thread) knit 1 R to the left at T 3. Transfer EOS to RB for K1/P1 Rib. T 1/1 I. RC 0. Knit to R 22, knitting last row to the left at T 10/5. Transfer RB Sts. to MB and BOLT.

NECKBAND: Close one shoulder first. With knit side facing rehang front/back of body on 72 (76) [80] ndls placing back/front as shown on chart. With Col. 1 (2 strands) and Col. 9, knit 1 R to the left. Transfer EOS to RB for K1/P1 Rib. T 1/1 I. RC 0. Knit 20 Rs. Transfer RB Sts. to MB and knit 1 R at T 4. Remove to WY.

SLEEVE:

With WY CO 46 (50) [54] Sts. After several rows, end with 1 R Ravel Cord to the right. RC 0. K-Carr. T 5. Follow intarsia pattern for back/front up to row 42 of intarsia pattern while incr on each side every 4 Rs 1 St. 12 x and every 5 Rs 1 St. 8 x (every 4 Rs 1 St. 8 x, every 5 Rs 1 St. 12x) [every 4 Rs. 1 St. 4x, every 5 Rs 1 St. 16 x]. At R 42, change to Col. 1 and K-Carriage (T 5). Knit in St. St. and continue incr. shaping to R 90 (94) [98]. Mark center with YM and remove on WY.

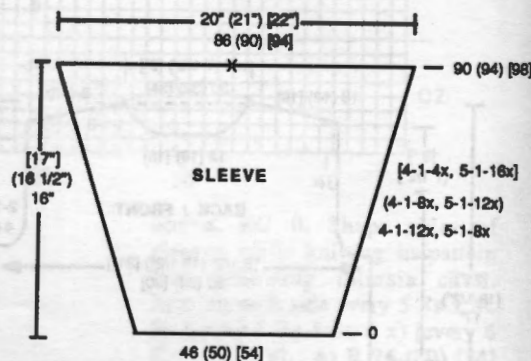

FRONT: Knit front same as back up to R 68 (72) [76] and mark each side with a YM for armhole. Begin large intarsia design at T 5.1. (see intarsia chart for pattern and color). After completing intarsia design continue in St. St. with Col. 1 to R 106 (112) [120] and begin neckline shaping. Place center 14 (16) [18] Sts. in HP and all Sts. to the left of these. *Shape neckline with SHR EOR 1 St. 10 x. At R 120 (126) [134] begin SHR shoulder shaping same as back. At R 126 (132) [140] remove right shoulder Sts. to WY. Turn RC to 106 (112) [120] and shape neckline reversing shapings from *. For neckline pick up extra sts. from neckline edge for a total of 44 (46) [48] Sts. Knit 1 R across all and remove neckline Sts. to WY.

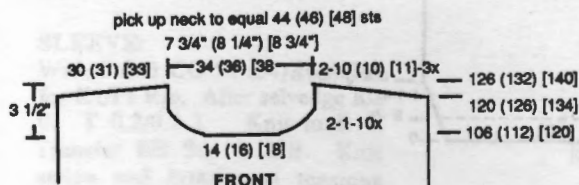

(continued next page)

(continued from previous page)

841

#840 - Mens Southwest Intarsia Pullover

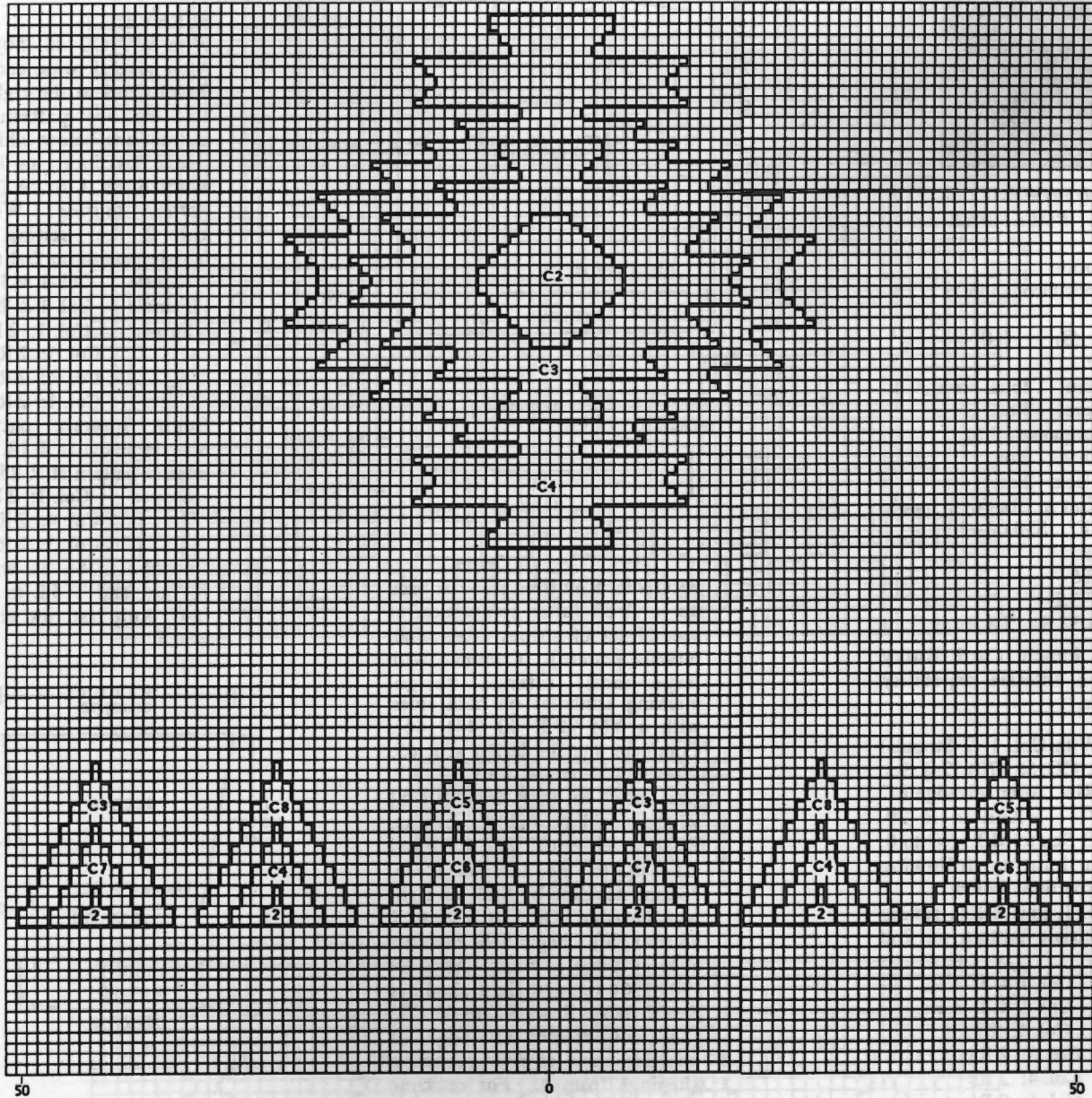

CUFF: With purl side facing rehang lower edge of sleeve onto 40 (42) [46] ndls., doubling evenly across. With Col. 1 (2 strands) and Col. 9 (elastic thread)

knit 1 R to the left at T 3. Transfer EOS to RB for K1/P1 Rib. T 1/1 I. RC 0. Knit to R 20, knitting last row to the left at T 10/5. Transfer RB Sts. to MB and BOLT.

FINISHING: Close all seams. Fold collar to the front and backstitch into open sts or complete on Lectrolink. **27**



BOYS SOUTHWEST INTARSIA PULLOVER

YARN: Softon
(2 strands throughout)

SIZES:
6 (8) [10]

AMOUNT:

- Col. 1: Ecru - 1 lb all sizes
- Col. 2: Coral - 3 oz.
- Col. 3: Turquoise - 2 oz.
- Col. 4: Khaki - 2 oz.
- Col. 5: Black - 2 oz.
- Col. 6: Knit in Elastic - 1 spool

KIT PRICE: \$30.00

TENSION:

- Intarsia: T6
- St. St.: T 5.2

GAUGE: 4.52 Sts, 5.8 Rs = 1"

Make on Punch Card Bulky knitter with Intarsia capability with Ribber.

BACK: With Col. 1 (2 Strands) and Col. 6, CO 66 (70) [74] Sts. for K1/P1 Rib. After selvedge RC 0. T 1/1 I. Knit to R 20. Transfer RB Sts. to MB. RC to 0. T6. Begin knitting following pattern instructions below:

With Col. 1, knit 2 Rs., setting ndls for fairisle pattern on 2nd row.

- Fairisle Col. 1 & 3: 4 Rs.
- Fairisle Col. 1 & 2: 4 Rs.
- Stripe: Col. 1: 2 Rs
- Col. 5: 2 Rs
- Col. 4: 2 Rs
- Col. 1: 2 Rs

Begin intarsia pattern (see intarsia chart) at R 18. Complete intarsia pattern at R 25.

- Stripe: Col. 1: 2 Rs
- Col. 4: 2 Rs
- Col. 5: 2 Rs

Change to Col. 1 and K-Carr. T 5.2. Continue in St. St. to R 40 (44) [46]. Place a YM on each side to mark armhole. Continue St. St. to R 78 (84) [90] where

SHR shoulder shaping begins. On each side SHR EOR 6 Sts. 2 x, 7 Sts. 1 x (6 Sts. 1 x, 7 Sts. 2x) [7 Sts. 3 x]. At R 84 (90) [96] mark center 28 (30) [32] Sts. for neckline and remove to WY.

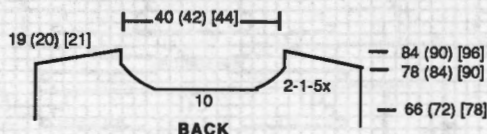
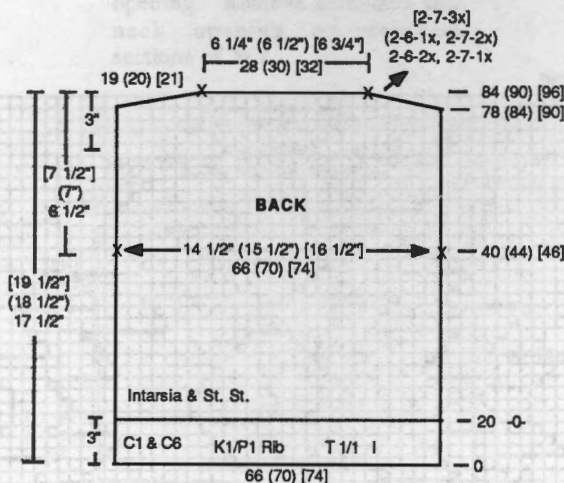

FRONT: Knit front same as back up to R 33 (after completion of second set of stripes after small intarsia pattern). Continue with large motif intarsia design, marking armholes on both sides with a YM at R 40 (44) [46]. Complete intarsia design at R 65. With Col. 1 and K-Carr. T 5.2. Knit in St. St. to R 66 (72) [78] where neckline shaping begins. Place center 10 Sts. in HP and all Sts. to the left of these. *Shape neckline by SHR on right neckline edge EOR 1 St. 5 x. At R 78 (84) [90] begin SHR shoulder shaping same as back. At R 84 (90) [96] remove right shoulder Sts. to WY. Reset RC to 66 (72) [78] and shape left edge of neckline same as right reversing shapings from *. For neckline pick up extra sts. from neckline edge for a total of 40 (42) [44] Sts. Knit 1 R across all and remove neckline Sts. to WY.

NECKBAND: Close one shoulder first. With purl side facing rehang front/back of body on 68 (72) [76] ndls placing back/front as shown on chart. With Col. 1 (2 strands) and Col. 6, knit 1 R to the left. Transfer EOS to RB for K1/P1 Rib.

NECKBAND

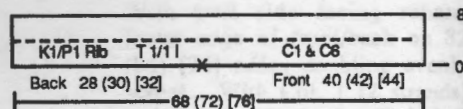

T 1/1 I. RC 0. Knit 8 Rs. Knit last row at T 8/4 I. Transfer RB Sts. to MB and BOLT.

SLEEVE:

With WY CO 46 (50) [52] Sts. After several rows, end with 1 R Ravel Cord to the right. RC 0. T6. Follow pattern knitting instructions below while shaping sleeve by incr. on both sides every 6 Rs 1 St. 9 (9) [10] x. *Pattern knitting:* With Col. 1, knit 2 Rs., setting ndls for fairisle pattern on 2nd row.

- Fairisle Col. 1 & 3: 4 Rs.
- Fairisle Col. 1 & 2: 4 Rs.
- Stripe: Col. 1: 2 Rs
- Col. 5: 2 Rs
- Col. 4: 2 Rs
- Col. 1: 2 Rs

Begin intarsia pattern (see intarsia chart) at R 18. Complete intarsia pattern at R 25.

- Stripe: Col. 1: 2 Rs
- Col. 4: 2 Rs
- Col. 5: 2 Rs

Continue in St. St. with Col. 1, K-Carr. and T 5.2 to R 58 (60) [64]. Knit last row at T 10 and BOLT.

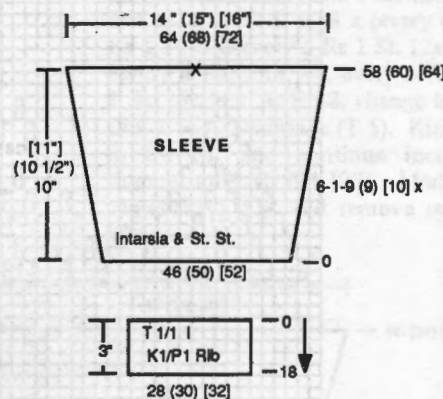

CUFF: With purl side facing rehang lower edge of sleeve onto 28 (30) [32] ndls., doubling evenly across. With main yarn (2 strands) and Col. 6 (elastic thread) knit 1 R to the left. Transfer EOS to RB for K1/P1 Rib. T 1/1 I. RC 0. Knit to R 18, knitting last row to the left at T 6/5. Transfer RB Sts. to MB and BOLT.

FINISHING: Close all seams.

Garment #841 - Boys Southwest Intarsia - Body

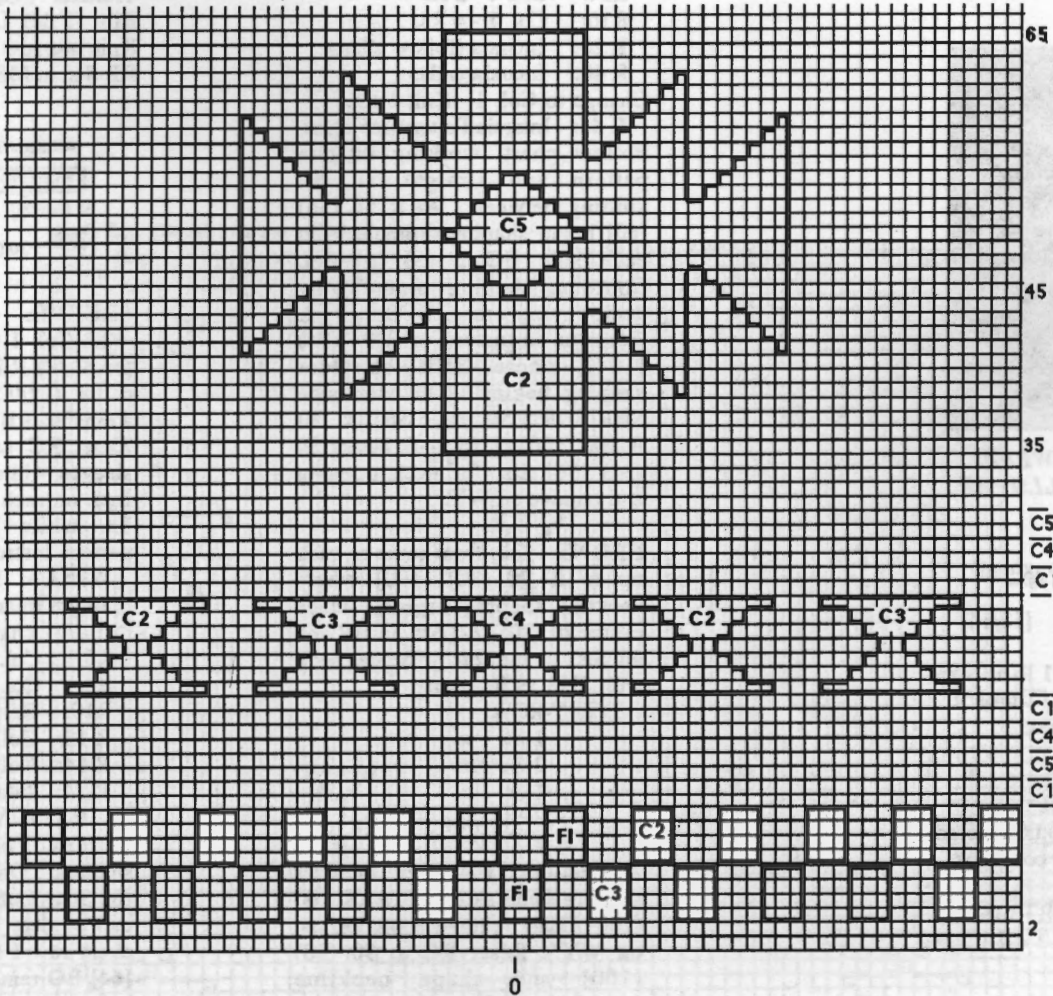

Garment #841
Fairisle Pattern - 24 Sts. 8 Rows

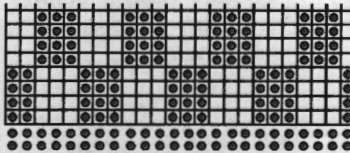

Boys Intarsia Pullover - Sleeve and Back

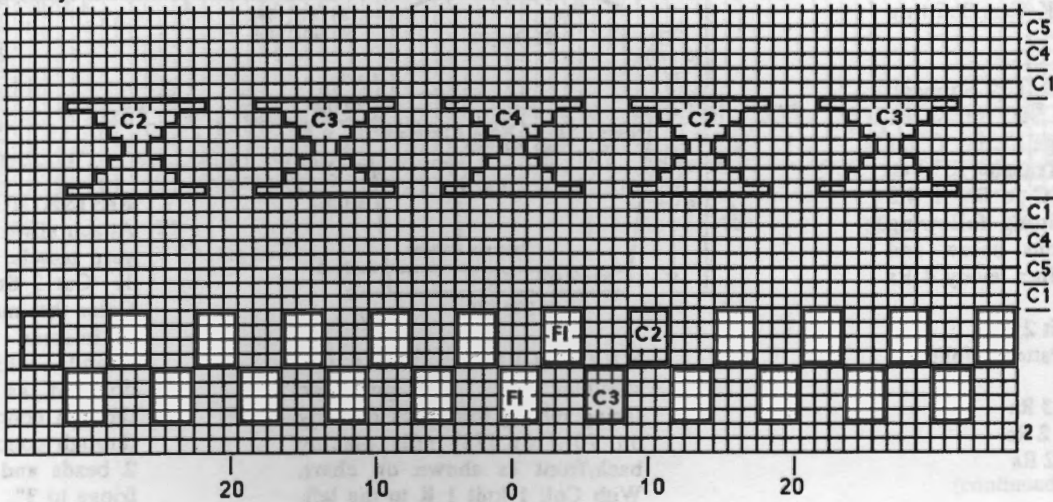



GIRLS SOUTHWEST INTARSIA PULLOVER

YARN: Softon

(2strands throughout)

SIZES:

6/8 (10) [12/14]

AMOUNT:

Col. 1: Black - 1 lb all sizes

3 ozs. each of Col. 2 thru 5:

Col. 2: Goldenrod

Col. 3: Purple

Col. 4: Red

Col. 5: Turquoise

KIT PRICE: \$35.00 (includes beads and silver conchos)

TENSION:

Intarsia: T 4.2 [(T 6)]

K-Carr St. St.: T 4.1 [(5.2)]

Rib: T 1/1 I

GAUGE:

5 [(5.3)] Sts.,

6.25 [(6.58)] Rs = 1"

Make on Punch Card Bulky knitter with Intarsia capability with Ribber.

Note: For solid rows of color between intarsia designs, you can continue using Intarsia technique or switch to K-Carr. for these sections. If so, Tension should be adjusted for K-Carr knitting (see above).

BACK: With Col. 1 (2 Strands), CO 76 (76) (80) Sts. for K1/P1 Rib. After selvedge RC 0. T 1/1 I. Knit to R 6. Transfer RB Sts. to MB. Reset RC to 0. T 4.2 [(6)]. Begin knitting following pattern instructions below and shaping sides by incr. every 4 Rs 1 St. 3x:

With Col. 1, knit 2 Rs.

Begin Intarsia Pattern, (follow chart)

R7: Col. 1 - 3 Rs

R10: Col. 2 - 2 Rs

R12: Col. 1 - 2 Rs

R14: Col. 4 - 2 Rs

R16: Col. 1 - 4 Rs.

R 20: Intarsia (follow chart)

R 40: Intarsia ends.

Change to Col. 1. Knit 6 Rs.

R 46: Intarsia Pattern-see chart Follow chart, working intarsia pattern and straight St. St. knitting between. At R 56 (56) [60] begin shaping armhole. On each side BO 5 (5) [6] Sts. Continue shaping armhole by decr. every row 1 St. 3 x. Continue in pattern to R 94 (94) [104] where SHR shoulder shaping begins. On each side SHR EOR 5 Sts. 2x, 6 Sts. 1x. At R 100 (100) [110] mark center 34 (34) [36] Sts. for neck opening and remove on WY.

FRONT: Knit front same as back up to R 90 (90) [100] where neckline shaping begins. Place center 20 (20) [22] Sts. in HP and all Sts. to the left. *Shape neck with SHR as follows:

EVERY ROW:

1 St. 1 x

2 St. 1 x

1 St. 1 x

2 St. 1 x

1 St. 1 x

At R 94 (94) [104] begin shoulder shaping same as back. At R 100 (100) [104] remove shoulder sts. on WY. Reset RC to 90 (90) [100] and shape neckline reversing shapings from *. Incr. neck Sts. to 38 (40) [42] by picking up Sts from side of neckline straight knitting. Knit 1 R over all then remove neck Sts. to WY.

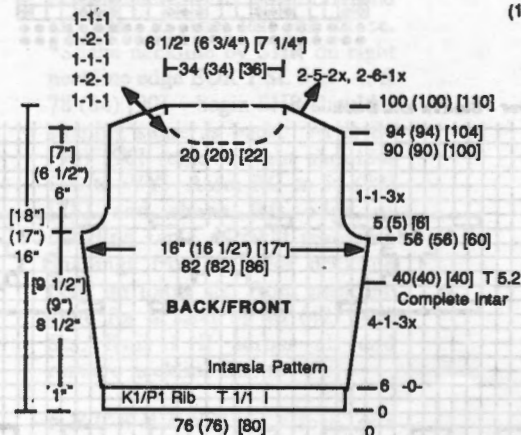

NECKBAND: Close one shoulder first. With purl side facing rehang front/back of body on 70 (74) [78] ndls placing back/front as shown on chart. With Col. 1 knit 1 R to the left.

Transfer EOS to RB for K1/P1 Rib. T 1/1 I. RC 0. Knit 6 Rs. Knit last row at T 8/4 I. Transfer RB Sts. to MB and BOLT.

NECKBAND

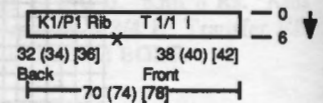

SLEEVE:

With Col. 1 CO 46 (50) [56] Sts. for K1/P1 Rib. After selvedge RC 0. T 0.2/0.2 I. Knit to R 6. Transfer RB Sts. to MB. T 6. Reset RC to 0. Shape sides of sleeves while knitting in pattern. Incr. on each side every 5 Rs 1 St. 5x. while knitting, following pattern instructions below:

With Col. 1, knit 2 Rs.

Begin Intarsia Pattern, (follow chart)

R6: Col. 1 - 2 Rs

R8: Col. 2 - 2 Rs

R10: Col. 1 - 2 Rs

R 12: Col. 3 - 2 Rs.

R 14: Col. 1. - 10 Rs.

R 24: Intarsia Pattern-see chart

R 30: While continuing in pattern, begin sleeve cap shaping. On each side BO 5 (5) [6] Sts. Continue shaping sleeve cap by decr EOR 1 St. 13 x, and every row 1 St. 4 x. At R 60 (60) [64] BO remaining Sts.

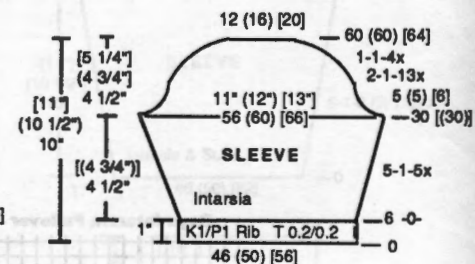

FINISHING: Close all seams. Attach silver conchos, beads and yarn tassels.

1. Cut 2 Strands (18" each) of Color that matches center section of intarsia. Fold in half for 4 strands which will then be doubled as they are worked through concho. After working through concho, tie knot, thread 2 beads and knot again. Trim fringe to 3".

Girls Southwest Intarsia - Body Front/Back

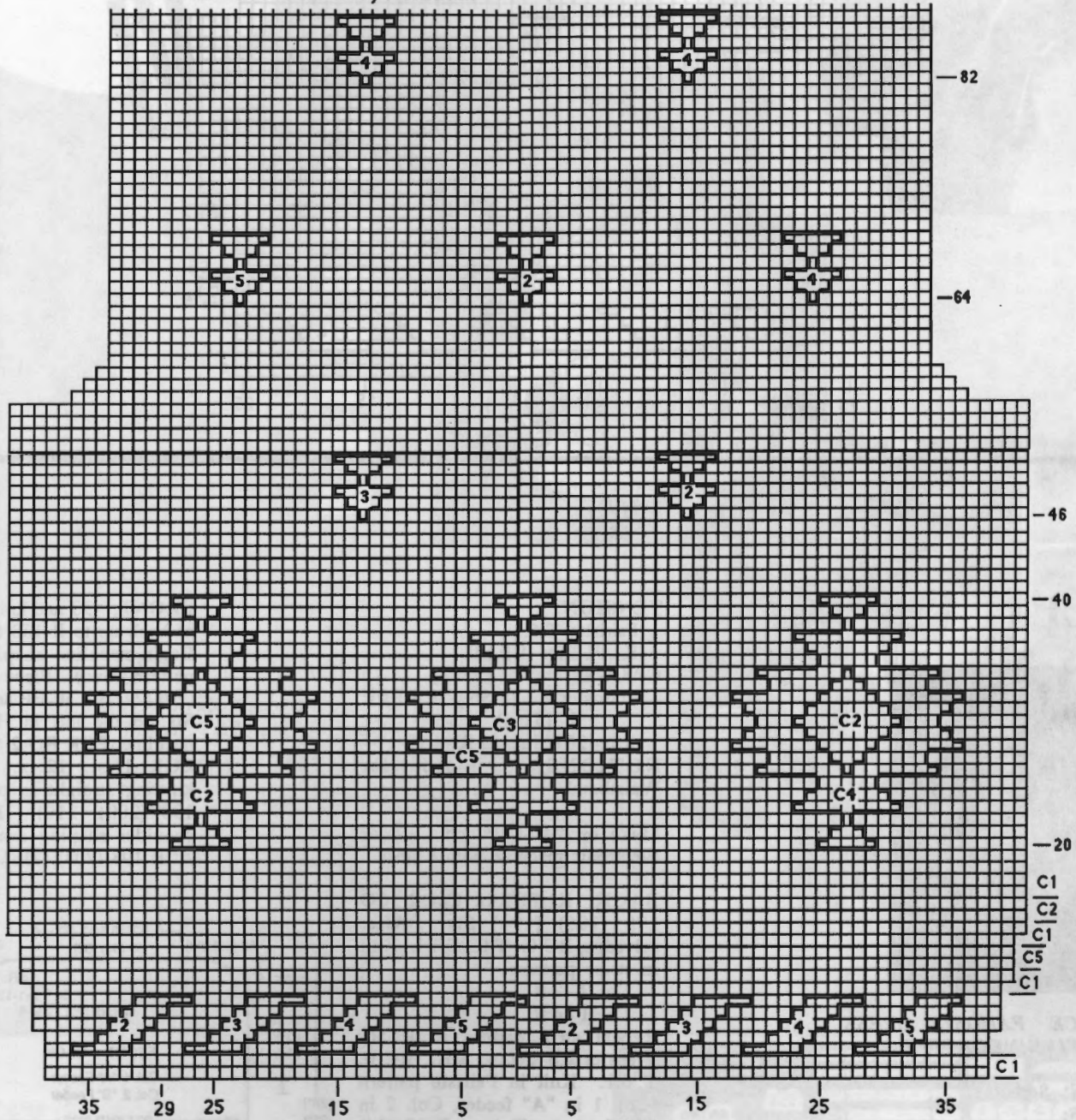

(continued from previous page)

Girls Southwest Intarsia - Sleeve

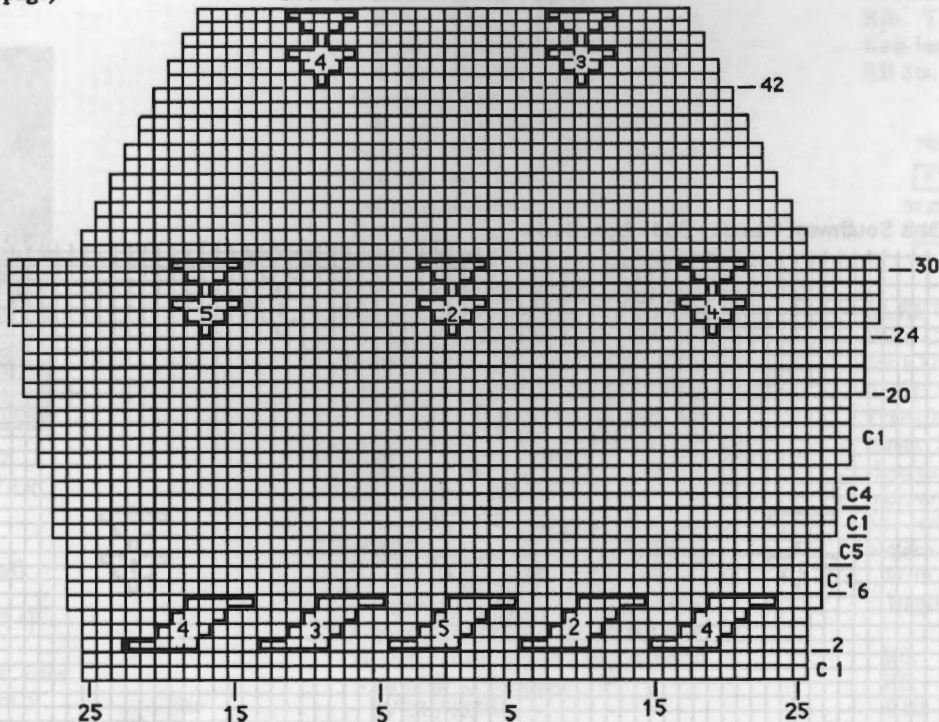

GIRLS SOUTHWEST
INTARSIA PULLO

YARN: Saiton
Catalina through
SIZES: M-
L-
XL-
Col. 1: Black-1 R
Col. 2: Orange
Col. 3: Blue

844



2-PIECE FAIRISLE DRESS
POSITIVE/NEGATIVE

YARN: Sorbet
SIZES:

6/8 (10/12) [14]

AMOUNT:

Col. 1: White
1 1/2 lb. (1 1/2 lb.) [2 lb.]
Col. 2: Black
1 1/2 lb. (1 1/2 lb.) [1 1/2 lb.]

KIT PRICE:
\$72.00 \$72.00 \$84.00

32

TENSION:

Fairisle: T 6.1
K1/P1 Rib: T 0.1/0.1 I

GAUGE:

Fairisle: 17.72 Sts., 19.8 Rs =
2" (5 cm)

Rib: 28.6 Sts., 25 Rs = 2"

NOTIONS: Elastic for
Waistband

Make on 24-St. Punch Card or
Electronic machine with Ribber.

BACK: K1/P1 Rib. Col. 2. CO
178 (186) [194] Sts. After
selvedge, RC 0. T 0.1/0.1 I. Knit
in stripe pattern:

Col. 2 - 2 R
Col. 1 - 4 R

Repeat strip pattern to R 50.
Transfer RB Sts. to MB. RC 0.
T 6.1. Knit in Fairisle pattern
(Col. 1 in "A" feeder, Col. 2 in
"B" feeder). Knit to R 88 (94)
[100] and mark both sides with
YM for armhole. Continue in
pattern to R 190 (200) [210].
Begin SHR shoulder shaping. On
each side SHR EOR 6 Sts. 4x. At
R 198 (208) [218] mark center 58
(60) [62] Sts. for neckline
opening with YM and remove on
WY.

FRONT: CO and knit front same
as back up to R 158 (168) [178].
Begin neckline shaping. (Note
pattern row.) Place center 18
(20) [22] Sts. in HP and place all
Sts. to the left in HP *Shape
neckline. EOR BO 2 Sts. 4 x and
EOR 1 st. 12 x. Continue
knitting straight in pattern to R
190 (200) [210]. Begin SHR
shoulder shaping same as back.
At R 198 (208) [218] reset RC to

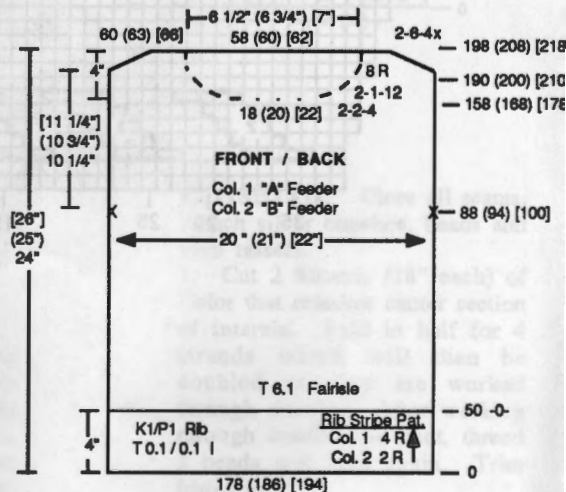

knitking COMPUKNIT

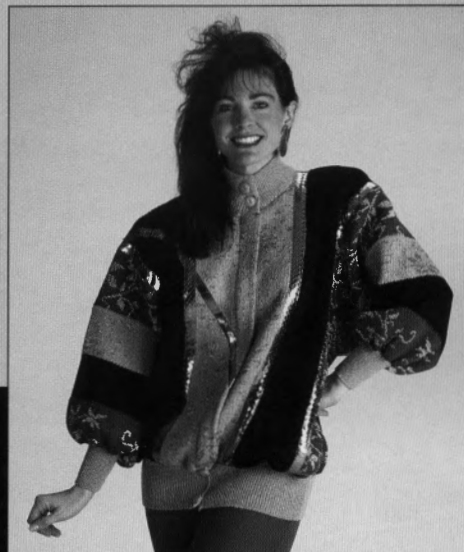
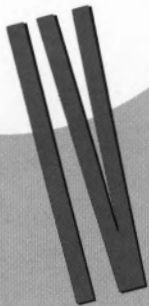

WITH THE AMAZING COMPUKNIT IV, IT IS POSSIBLE TO KNIT AND WEAR ANY OF THESE BEAUTIFUL GARMENTS IN ONE DAY—AT ONLY THE COST OF YOUR YARN.

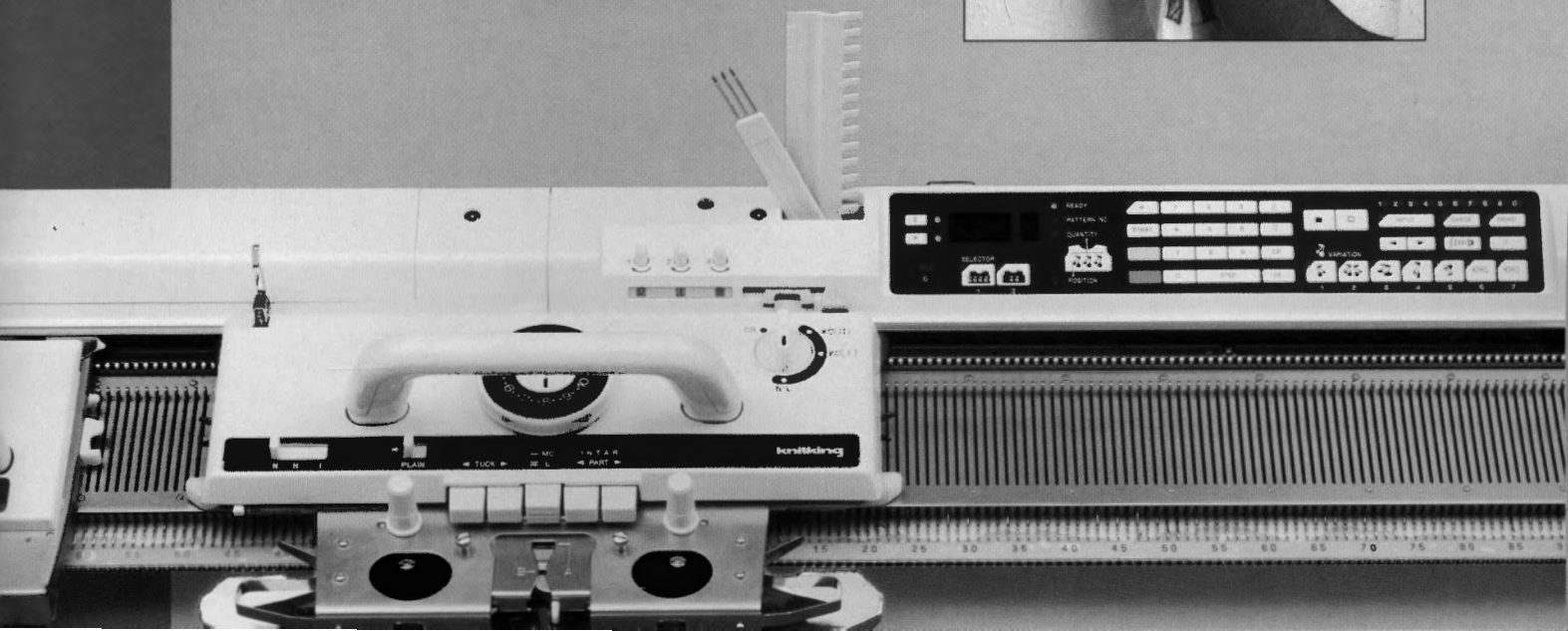

COMPUKNIT IV

INCREDIBLE VERSATILITY PLUS SIMPLICITY OF OPERATION

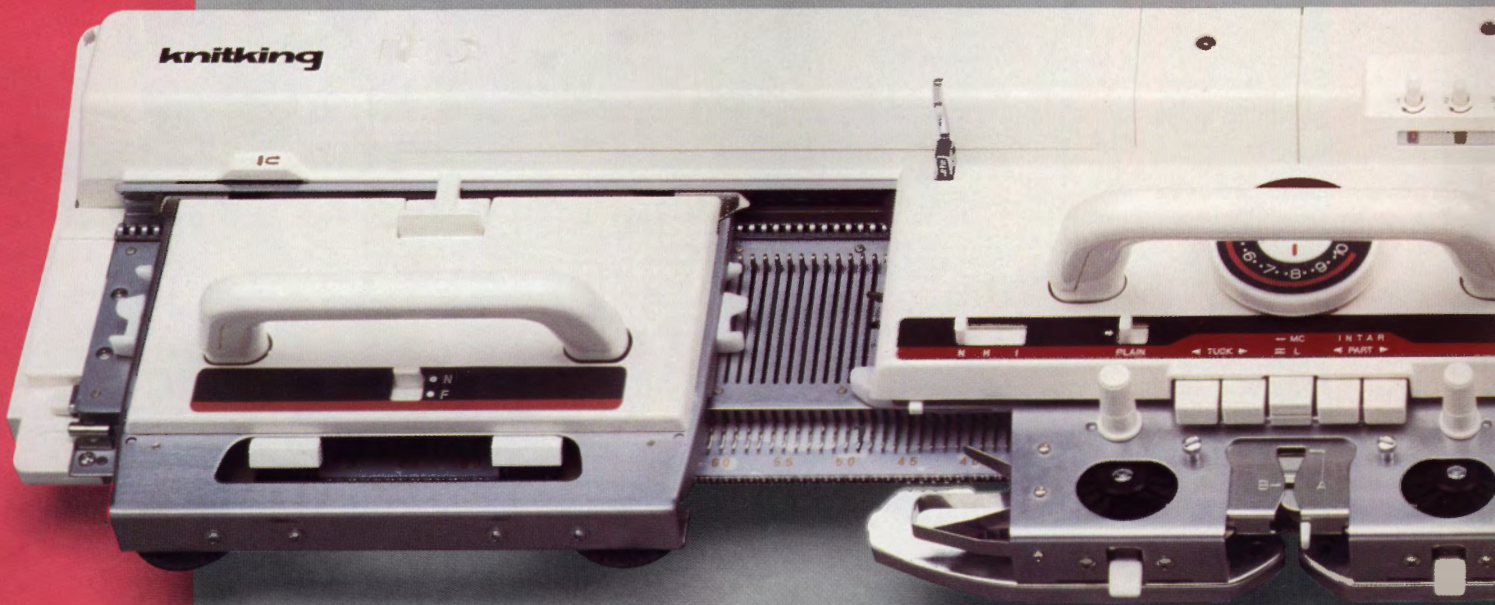

The COMPUKNIT IV is shown with Lace Carriage and Main Knitting Carriage. Both carriages are standard. Complete stitch and pattern capabilities are built into the COMPUKNIT IV, including Fair Isle, Tuck, Skip. The exclusive features of the COMPUKNIT IV achieve the ultimate in versatility and make this knitter an

DESIGNER'S DREAM ACCESSORIES

PATTERN DESIGN COMPUTER



The Pattern Design Computer is an accessory specifically designed for the CompuKnit IV. It is a small masterpiece of computer engineering and is remarkably easy to use. You connect its cord to your color television set and draw your own original designs, in the yarn colors of your choice, on the T.V. screen. The designs transfer directly to your CompuKnit IV for reproducing in your garment.

The 555 designs stored in the CompuKnit IV are also stored in the Pattern Design Computer. You can project them onto your T.V. screen and modify or combine them to suit your own taste and needs. You can also isolate any section of a design and transfer it to your knitter.



ful contemporary c

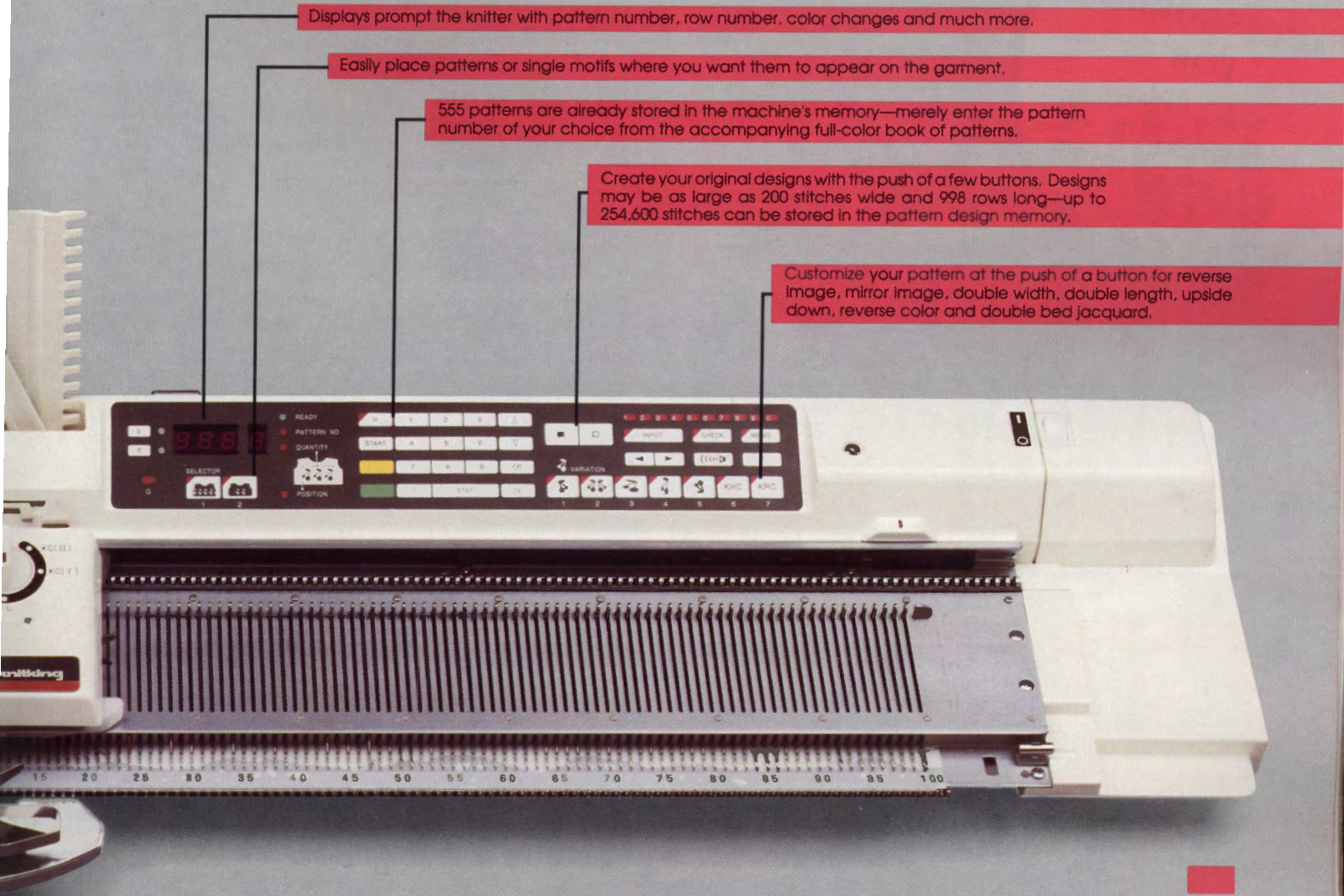

Displays prompt the knitter with pattern number, row number, color changes and much more.

Easily place patterns or single motifs where you want them to appear on the garment.

555 patterns are already stored in the machine's memory—merely enter the pattern number of your choice from the accompanying full-color book of patterns.

Create your original designs with the push of a few buttons. Designs may be as large as 200 stitches wide and 998 rows long—up to 254,600 stitches can be stored in the pattern design memory.

Customize your pattern at the push of a button for reverse image, mirror image, double width, double length, upside down, reverse color and double bed jacquard.

to the COMPUKNIT IV.

al and Fine Lace, Thread Lace, Weaving, Plating and Intarsia Knitting.

ably simple knitting machine to operate.



DISK DRIVE



The Disk Drive plugs into the back of the Pattern Design Computer, or directly into the back of the CompuKnit IV. The Disk Drive is used for transferring your own pattern stitch designs onto a disk for recall any time you need them. Or you can use these disks to serve as an extra copy of original patterns that you have already stored in the CompuKnit IV's memory. Additionally, pre-programmed disks are available, holding many beautiful

The Disk Drive uses convenient 3.5 inch micro diskettes.



PRINTER

Attach the Printer to the Pattern Design Computer and you are able to print copies of all of your own designs, as well as those available on any pre-programmed disks. The printout even indicates color changes and filling information. The Printer comes complete with a customized "Kwik-Konnect" cable to allow it to communicate with the Pattern Design Computer.

ACCESSORIES
FOR
EVEN
GREATER
VERSATILITY

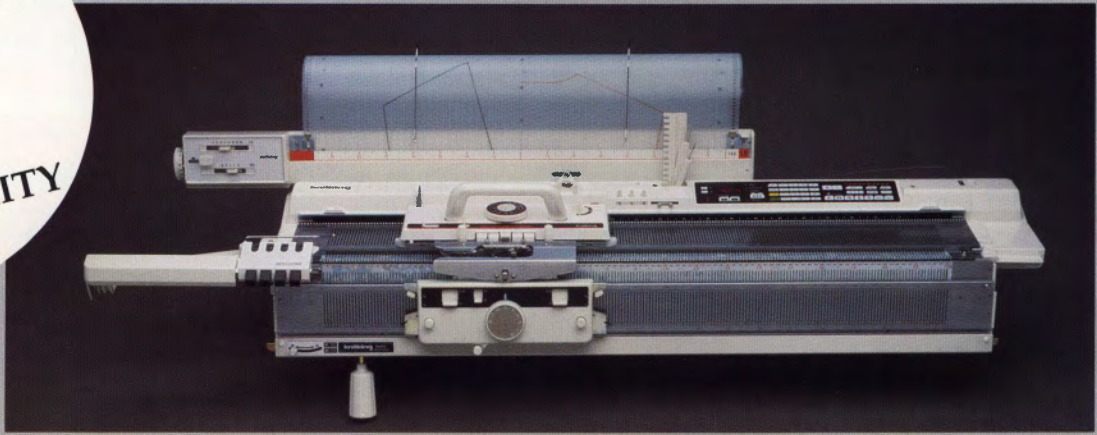

The Compuknit IV is shown with the RK 900 Ribbing Attachment, the Ribber Color Changer and the KL 16 Knitleader (all three are optional).

RIBBING ATTACHMENT

Add the Ribbing Attachment to your Compuknit IV and convert it into a double bed knitting machine, allowing you to knit any combination of rib designs over a total of 400 needles. The popular Fisherman's Rib, as well as racking designs, cable stitches, tubular knitting and much more are all made easy with this useful accessory.

FOUR-COLOR CHANGER

Add the Ribber Four-Color Changer to your knitter and Ribber combination and you will be able to knit beautiful multi-color Jacquard designs with as many as four colors in one row. It also eliminates the 'floats' from the back of Fair Isle knitting. The Knitter Color Changer, not illustrated, functions on the Compuknit IV (without Ribber). It enables you to knit up to four colors in a stitch design automatically, and to change colors with the push of a button.

KNITLEADER

Add a KL 16 Knitleader and you are able to create a full size chart of the garment you are knitting, which rotates row by row and tells you exactly when and where to increase and decrease stitches for accurate garment shaping.

COMPUKNIT GARTER CARRIAGE

This remarkable, electrically propelled Carriage automatically casts on, binds off and knits a multitude of Ribbing Stitches and fancy Garter Stitch patterns—beautiful, textured, three-dimensional designs impossible to knit any other way. You simply enter a design number into your Compuknit IV, set the number of rows needed, switch on your Garter Carriage and leave to do other things. It will move across the knitting machine on its own power and switch itself off when a ribbing or garter section is completed or if the yarn runs out or breaks.

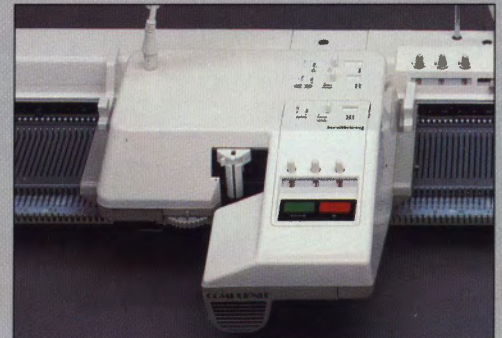

POWER DRIVE UNIT

Attach the Power Drive Unit (PDU) to the Compuknit IV and it will automatically move the carriage back and forth across the knitting bed in a smooth and easy fashion, significantly reducing your knitting time. Merely set the number of rows needed and the PDU will switch itself off when the rows are completed or if the yarn runs out, knots or breaks. The PDU will accommodate the Compuknit IV by itself, or with the Ribber, Four-Color Changer and Knitleader.



knitking

Where Savings And Value
Are Always In Fashion

158 (168) [178] and pattern to row noted above and shape neckline and shoulder from *, reversing shapings. Remove shoulder Sts and center neckline sts. on separate WY.

SLEEVE: With Col. 2 CO 84 (92) [98] Sts for K1/P1 Rib. After selvedge, T 0.1/0.1 I. RC to 0. Knit in stripe pattern same as back body. Knit to R 40. Transfer RB Sts. to MB and reset RC to 0. Incr. 2 Sts. on each side. Knit in fairisle pattern with Col. 1 in Feeder "A" and Col. 2 in Feeder "B" while shaping sleeve. Incr. EOR 1 St. 4 x (for all sizes), every 4 Rs 1 St. 35 (31) [35] x and every 4 Rs 1 St. 2 (6) [4] x. At R 158 (164) [170] BO.

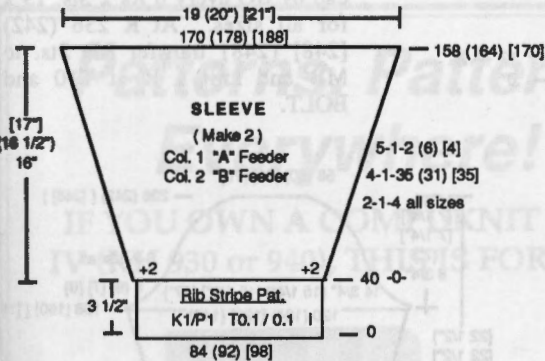

NECKBAND: Close one shoulder. CO 154 (160) [166] Sts. for K1/P1 Rib. After selvedge T 1/1 I. RC 0. Knit in stripe pattern same as waistband and cuff to R 26. Transfer RB Sts. to MB. With purl side facing rehang front/back neck on needles as shown on chart. Knit 1 R at T 10 and BOLT. Fold neckband to inside and whip stitch or attach entire band with Lectrolink.

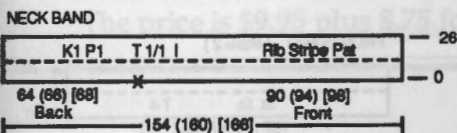

SKIRT: With WY CO 170 (178) [186] Sts. After several rows, end with 1 row Ravel Cord to the right. Change to Col. 2. T 6. Knit 1 R to set ndls for fairisle pattern. Add Col. 1 in Feeder "B" and knit in fairisle to R 10. RC 0. T 6.1. Knit 10 Rs. Pick up Sts. from first row to form hem. Continue knitting in pattern to R 100. Mark both sides with a YM for aid in seaming. Continue fairisle knitting to R 176 (186) [196]. On each side every 10 Rs decr. 1 St. 6 x for all sizes. At R 236 (246) [256] SHR on each side EOR 10 Sts. 3 x for additional side shaping. At R 242 (252) [262] knit 1 R across all Sts. and remove on WY.

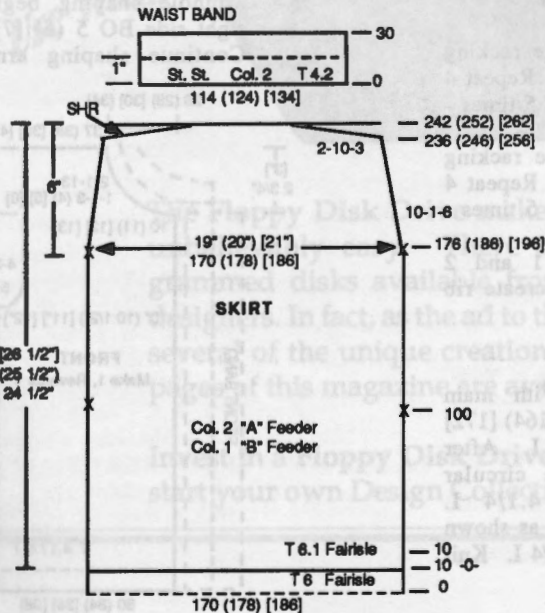

Garment #843
Fairisle Pattern 24 Sts. x 48 Rows

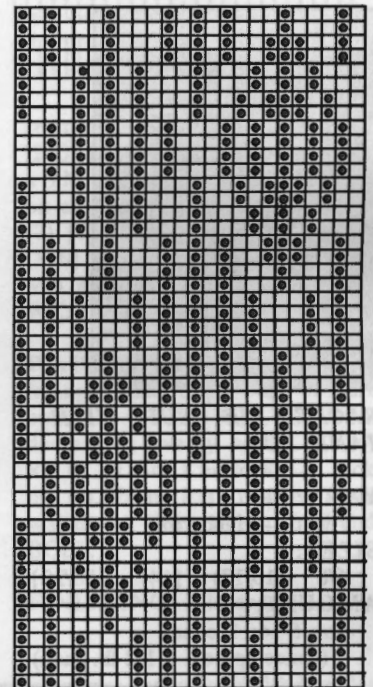

WAISTBAND: Make 2. With purl side facing rehang upper edge of skirt front/back on 114 (124) [134] ndls, decr. evenly across. RC 0. T 4.2. St. Col. 2. Knit to R 30. Pick up Sts. from first row to form doubled band. Knit 1 R at T 10 and BOLT.

FINISHING: Close seams.



RACKED-RIB SUIT WITH TANK TOP

YARN:

Venetia - Mandarin

SIZES:

6/8 (10/12) [14] (18/22)

AMOUNT:

Size 6-14: 2 cones
(cones approx. 1 1/2 lb. each)

Size {18/22}: 3 cones

KIT PRICE:

Size 6-14: \$ 78.00

Size {18/22}: \$118.00

TENSION:

Jacket: T 4.1/4 I

Skirt: T 4/4 I

GAUGE:

Jacket: 16.4 Sts., 22 Rs = 2"

Skirt: 15.42 St., 23.08 Rs = 2"

NOTIONS: Elastic for Skirt

Make on Standard Gauge machine with Ribber. Garment is worn on the purl side.

Note: For tank top pattern, see Pattern #836 this issue.

RACKING PATTERN

INSTRUCTIONS:

1. Knit 2 Rs. Move racking handle 1 step to Right. Repeat 4 more times (for total of 5 times - 10 rows).

2. Knit 2 Rs, move racking handle 1 step to Left. Repeat 4 more times (for total of 5 times - 10 rows)

3. Repeat steps 1 and 2 throughout knitting to create rib pattern.

JACKET BACK: With main yarn, CO for FNR 156 (164) [172] [188] Sts with T 1/1 I. After selvedge, knit 12 Rs circular method at tension 4.1/4 I. Transfer RB Sts to MB as shown on chart. RC 0. T 4.1/4 I. Knit

in racking pattern as above to R 156 (160) [164] [168] where armhole shaping begins. ON EACH SIDE BO 4 (5) [6] [8] Sts. Continue shaping armhole by decreasing with 2-prong transfer tool every 4 Rs 2 Sts 6 x for all sizes. Knit to R 260 (270) [280] [290]. Transfer RB Sts. to MB and knit 1 R at T 10. Place a yarn marker to mark center 50 (54) [58] [62] Sts. for neckline and BOLT.

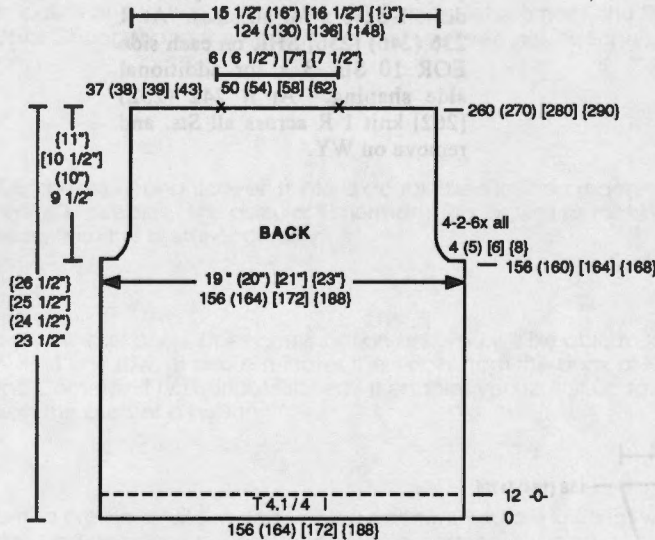

JACKET FRONT:

Make 1, Reverse 1.

With main yarn, CO for FNR 80 (84) [88] [98] Sts. at T 1/1 I. After selvedge, with T 4.1/4 I knit 12 Rs in circular method. Transfer RB Sts to MB as shown on chart. T 4.1/4 I. RC 0. Knit in racking pattern as above to R 156 (160) [164] [168] where armhole shaping begins. On right side BO 5 (6) [7] [9] Sts. Continue shaping armhole by

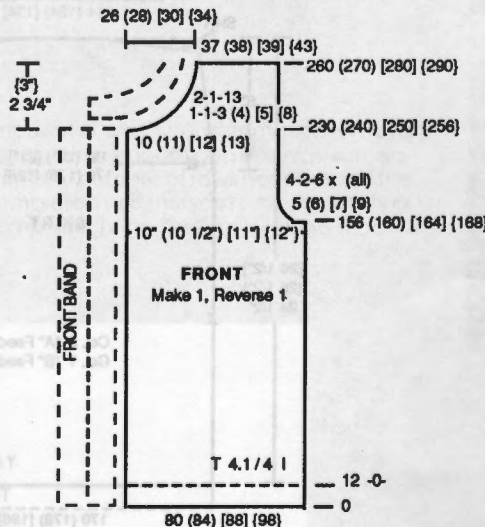

decreasing with 2-prong transfer tool every 4 Rs 2 Sts 6 x for all sizes. Knit to R 230 (240) [250] [256] and begin shaping neckline. On neckline edge BO 10 (11) [12] [13] Sts. Continue shaping neckline by decr. every row 1 St. 3 (4) [5] [8] x. Then decr. EOR 1 St. 13 x. (all sizes). Knit to R 260 (270) [280] [290]. Transfer RB Sts. to MB and knit 1 R at T 10 and BOLT. Make second jacket front piece reversing shapings.

SLEEVE: With main yarn CO for FNR 56 (60) [64] [70] Sts. with T 1/1 I. After selvedge knit 12 Rs circular method at tension 4.1/4 I. Transfer RB Sts. to MB as shown on chart. T 4.1/4 I. RC 0. Knit in racking pattern while shaping sleeves by incr. (sizes 6-14) every 4 Rs 1 St. 6 x and every 5 Rs 1 St. 26x (size 18/22 incr. every 4 rows 1 St. 17 x and every 5 Rs 1 St. 18 x). At R 156 (160) [164] [164] begin sleeve cap shaping. ON EACH SIDE BO 5 (6) [7] [9] Sts. Continue shaping cap by BO every 6 Rs 2 Sts. 13 x for all sizes. At R 236 (242) [248] [248] transfer RB Sts. to MB and knit 1 R at T10 and BOLT.

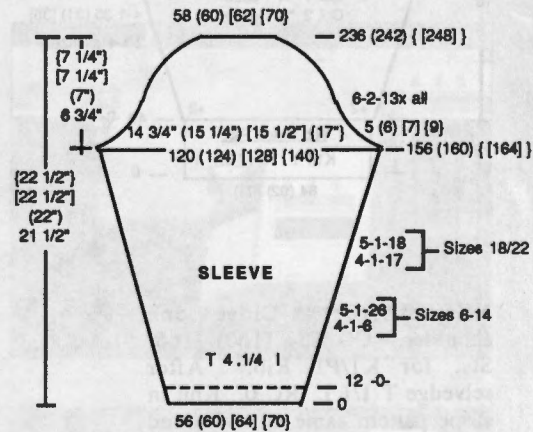

JACKET FRONT BANDS:

Make 2.

With knit side facing rehang section of jacket front along front edge onto 152 (160) [168] [176] Sts. RC to 0. T 4. St. St. Knit to R 22. Pick up Sts. from first row to form doubled band. Knit 1 R at T10 and BOLT.

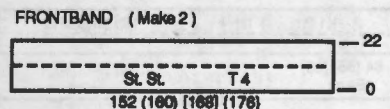

JACKET NECK BAND: Close shoulder seams on jacket front/back. With knit side facing rehang neckline on 104 (110) [118] {126} Sts. T 4. St. St. RC 0. Knit to R 22. Pick up Sts. from first row to form doubled band. Knit 1 R at T 10 and BOLT.

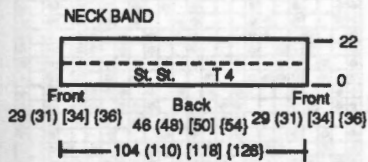

SKIRT: With main yarn CO for FNR 146 (154) [162] {184} Sts. with T 1/1 I. After selvedge transfer RB Sts. to MB as shown on chart. With T 4/4 I, knit in racking pattern to R 100. Mark each side with a YM for aid in

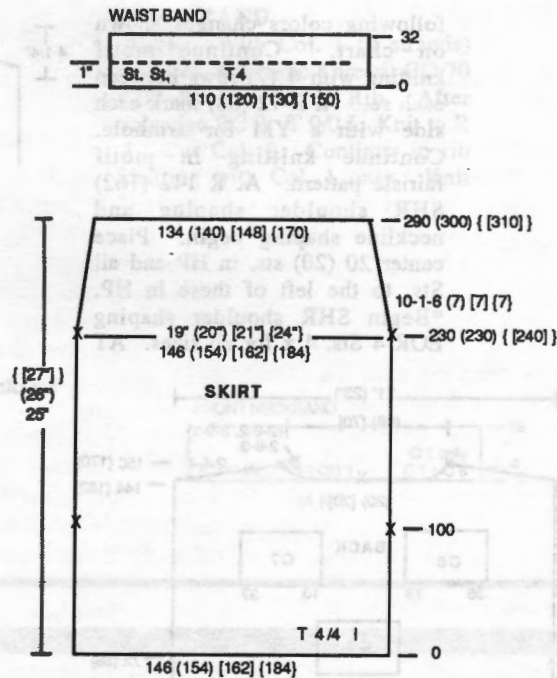

Needle Arrangement for Racking



seaming. Knit to R 230 (230) [240] {240}. Mark each side with a YM and begin shaping by dec. on each side every 10 Rs 1 St. 6 (7) [7] {7} x. At R 290 (300) [310] {310} transfer RB Sts. to MB and knit 1 R. Remove on WY.

WAISTBAND: With knit side facing, rehang upper edge of skirt onto 110 (120) [130] {150} ndls. decreasing evenly across. T 4. RC 0. St. St. Knit to R 32. Pick up sts. from first row to form waistband. Knit 1 R at T 10 and BOLT.

FINISHING: Join seams.

Patterns, Patterns Everywhere!

IF YOU OWN A COMPUKNIT III or IV (KH 930 or 940), THIS IS FOR YOU:



A Pre-Programmed Floppy Disk with all of the Pattern Stitches (except Intarsia and Bulky) for the garments in this issue. Just insert the Disk into your Floppy Disk Drive, enter the Pattern Stitch of your choice and . . . Away You Go!!!

Also available for back issues starting with 22 #1

The price is \$9.95 plus \$.75 for shipping.

FDD 19

FLOPPY DISK DRIVE FOR COMPUKNIT III or IV



For Use With:

The Floppy Disk Drive makes pattern work unbelievably easy. There are many programmed disks available from a variety of designers. In fact, as the ad to the left explains, several of the unique creations found on the pages of this magazine are available on disk.

Invest in a Floppy Disk Drive today . . . and start your own Design Collection tomorrow!



OVERSIZE PULLOVER WITH RANDOM MOTIFS

YARN: Softon (2 strands throughout)

SIZES: Small (Med/Large)

AMOUNT:

Col. 1: Ecru 1 1/2 lb. 2 lb.

Col. 2 thru 7: 2 oz. each color

Col. 2: Goldenrod
Col. 3: Turquoise
Col. 4: Cottage Rose
Col. 5: Emerald
Col. 6: Red
Col. 7: Purple
Col. 8: Knit-in Elastic-Ecru

KIT PRICE:

\$44.00 (\$53.00)

TENSION:

Body: T 3.2
Rib: T 0/0 I

GAUGE:

Body: 9.54 Sts, 13 Rs = 2"

Make on Punch Card Bulky with Ribber, using isolations bars for motif designs. See Manual for Instructions on knitting in Fairisle Motif - Page 35.

BACK: With Col 1 (2 strands), CO 100 (110) Sts. for K1/P1 Rib. After selvedge RC 0. T 0/0 I. Knit to R 20. Transfer RB Sts. to MB. RC 0. T 3.2. Carr. on right. With Col. 1 knit 1 (3) Rs ending with carr. on left. Knit 1 R to the right to set needles. With Col. 2 in "B" feeder, activate card for fairisle knitting and knit 30 rows. At pattern row 30 all ndls in motif should be in "C" position to "close" motif square. Knit 4 (7) rows between patterns, beginning next motif designs as shown on chart. At mid-point of each row where there are side-by-side motifs, change contrast yarn

36

following colors changes shown on chart. Continue motif knitting with 4 (7) rows between each set. At R 72 (88) mark each side with a YM for armhole. Continue knitting in motif fairisle pattern. At R 142 (162) SHR shoulder shaping and neckline shaping begin. Place center 20 (20) sts. in HP and all Sts. to the left of these in HP. *Begin SHR shoulder shaping EOR 4 Sts. 4 x for all sizes. AT

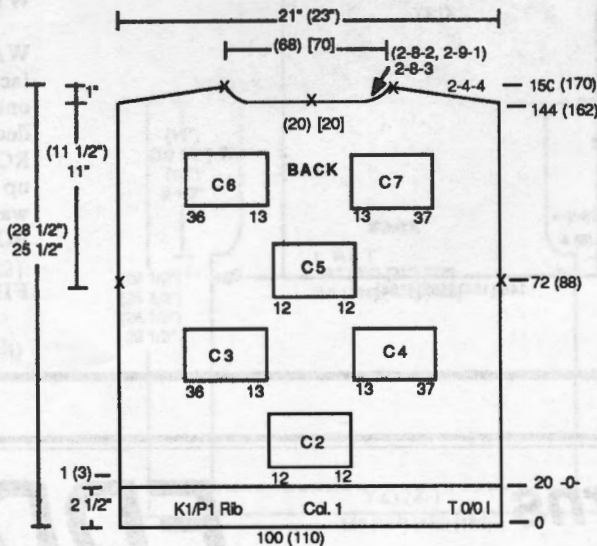
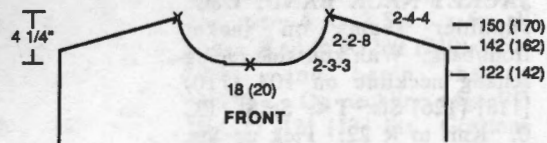

SLEEVE: With WY CO 64 (68) Sts. After several rows, end with 1 R Ravel Cord to the right. RC 0. T 3.2. With Col. 1 knit 2 Rs, setting ndls for fairisle motif on 2nd row. Activate card, following motif needle placement and colors as shown on chart. Note reverse placement and colors for each sleeve as shown on chart. Shape sleeve on each side incr. every 6 Rs 1 St. 16 x (every 6 Rs 1 St. 12 x, and every 7 Rs 1 St. 4 x). Knit to R 96 (100) knitting last row at T 10. BOLT.

THE SAME TIME shape neckline EOR 8 Sts. 3 x (8 Sts. 2 x, 9 Sts. 1 x). At R 150 (170) knit 1 R over shoulder sts. at T 10 and BOLT shoulder Sts. Reset RC to 142 (162) and shape remaining shoulder and neckline from *. Remove neck opening on WY.

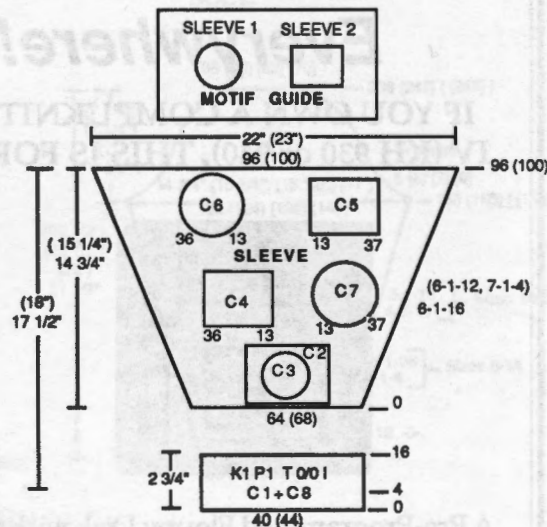

FRONT: Knit front same as back up to R 122 (142) where neckline shaping begins. Place the center 18 (20) Sts. in HP. Place all Sts. to the left in HP. *On neckline edge BO EOR 3 Sts. 3 x and EOR 2 Sts. 8 x. At R 142 (162) begin SHR shoulder shaping same as back. At R 150 (170) knit 1 R over shoulder sts. at T 10 and BOLT shoulder sts. Reset RC to 122 (142) and shape neck and shoulders from *. Remove neckline sts. on WY.

CUFF: With Col. 1 (2 strands) and Col. 8, CO 40 (44) Sts. for K1/P1 Rib. After selvedge, RC 0. T 0/0 I. Knit to R 4. Cut Col. 8 (Elastic thread) and continue to R 16 with Col. 1 only. With purl side of lower sleeve facing, rehang on 40 (44) ndls. decreasing evenly across. Knit 1 R at T 10 and BOLT.

Fairisle Motif 24 Sts 30 Rows

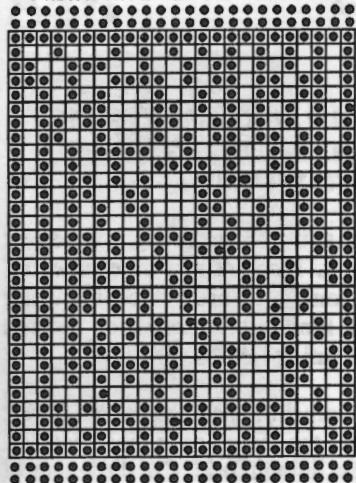

Row 1-Punch Card

NECKBAND:

Back: With Col. 1 (2 strands) and Col. 8 (Elastic Thread) CO 70 (72) Sts. for K1/P1 Rib. After selvedge RC 0. T 0/0 I. Knit to R 4. Cut Col. 8. Continue in rib knitting with Col. 1 only. Knit

BACK NECKBAND

K1/P1 Rb	T 0/0 I	C 1 only	16
		C 1 + C 8	4
			0
70 (72)			

to R 16. With purl side of back facing, rehang neck on 70 (72) ndls. Knit 1 R at T 10 and BOLT. Front: With Col. 1 (2 strands) and Col. 8 (Elastic Thread) CO 84 (86) Sts. for K1/P1 Rib. After selvedge RC 0. T 0/0 I. Knit to R 4. Cut Col. 8. Continue in rib knitting with Col. 1 only. Knit to R 16. With purl side of front facing, rehang neck on 84 (86) ndls. Knit 1 R at T 10 and BOLT.

FRONT NECKBAND

K1/P1 Rb	T 0/0 I	C 1 only	16
		C 1 + C 8	4
			0
84 (86)			

FINISHING: Close all seams.

Your Own Knitwear Design Studio!



The exciting KC IIIXT knitting machine accessory is a "dream come true" for the knitter who likes to create her own designs. With a memory that will store up to 100 original patterns, the KC IIIXT makes the sky the limit for the sheer number of original creations that can be designed and stored.

The KC IIIXT was originally designed for use with a **Compuknit III or IV**. But, you will be excited to know that it will also work with the brand new **Compuknit/Bulky** (using a special cartridge) adding a long-awaited design dimension for this newest member of our knitting machine family.

By turning your **color television set into a knitwear design studio**, you can indulge all of your creative fancies, while at the same time make fine-tuning adjustments in your beautiful designs with the push of a button. Then, you can experiment with different yarn color combinations *right on your T.V. screen* and in seconds start knitting your new pattern automatically!

The KC IIIXT has become the standard in knitwear design technology. And, sale priced at \$499.95, the KC IIIXT is priced right if you're a designer at heart . . . or would like to be.

INNOVATIVE KNITTING TECHNIQUES

by: Jan Wold and Jan Mills

Jan Wold and Jan Mills, authors of the Going Places knitting books, teach and write about a variety of new and interesting techniques for machine knitters. Here are several helpful hints to make knitting easier and more fun.

PUTTING ELASTIC IN YOUR RIBBING

Many yarns lack the necessary body to create a rib with the desired shape. The following is a new cast on method using elastic to help keep the shape of the ribbing. This method is helpful with many acrylics, such as orlon, and especially with natural fibers with limited body, such as cotton and silk.

Step One

"e" wrap the number of needles required for your pattern. Needles should be in hold position ('E') for the "e" wrap cast on.

Step Two

Cut a piece of elastic longer than your working needles. Use the elastic that comes in a cording. Weave this elastic over one needle in hold position and under the next one. Continue across the machine so that you have the elastic under every other needle and on top of the adjacent needle. Place your weaving brushes in "on" position. Knit 1 row at garment tension minus 1. Transfer every other needle to the Ribber. Hang ribber cast-on-comb and ribber weights. Adjust tension dials to the proper ribbing tension on both beds with slide lever at II. Knit the number of rows in ribbing as required by your pattern. Transfer Ribber stitches back to Main Bed. Change to Main Bed coupler and remove ribber weights. Row Counter 000.

Step Three (Optional)

Bring every other needle to hold position. Lay another piece of elastic across the needles in hold position. Make sure weaving brushes are still engaged. Change to garment tension. Knit 1 row. Continue with your pattern.

MAKING A LINING FOR YOUR KNIT SKIRT TO MATCH THE COLOR OF YOUR YARN. THIS LINING WILL BE PERMANENTLY ATTACHED TO THE SKIRT

Select the proper fabric to use for the lining. The easiest fabric to find is a polyester lining. It comes in a wide variety of colors making it easy to match your knit fabric. Tricot is another lining fabric, but usually has a limited color selection and has more stretch than the polyester lining fabrics.

Next, determine the number of needles required for 1/2 of your waistband sts. Measure the length over those needles. That is the width you will cut the lining fabric. Cut the length of the lining 1/2 inch longer than the measurement from the hem edge of the skirt to the lower edge of the waistband.

Knit your skirt from the lower edge to the top edge which will adjoin the waistband. Remove skirt stitches on Ravel Cord and waste yarn. Block the skirt to the correct measurement.

Next, make facing for the waistbands. Cast on with waste yarn the number of stitches needed for the waistband and knit several rows. Knit 1 row of Ravel Cord. Change to main color yarn and knit 12 to 14 rows of main color yarn. You want enough rows to cover the elastic you will use in the waistband. Remove these stitches on a garter bar or one row of ravel cord and several rows of waste yarn. Rehang the upper edge of your skirt on the number of needles required for the waistband, doubling up stitches evenly across as required. Proceed to hang the lining fabric that you have cut, dropping it 1/4" from the upper edge (you can mark your fabric with a fabric marking pen if you want—it will help you follow a straight line); poke through the material with a one-eyed transfer tool at the right edge of your fabric and place the fabric on the right end needle in work. Fold the material in half and again, with your one-eyed tool, poke a hole into the fabric and place the fabric onto a needle in the center of the machine. Repeat on the left edge of your fabric, placing the hole onto the left edge needle. Now fill in across the needle bed. Take the fabric behind the latches. Rehang your facing from the garter bar (or from ravel cord and scrap)—making sure you hang the main color stitches with the wrong side facing you. These stitches are placed behind the latches as well. Knit the same number of rows you had in the facing. Rehang to the first row of main color yarn of the facing. There will be 2 stitches on each needle. Bindoff around the gate pegs. Lay out skirt on blocking/cutting board and cut lining to fit skirt leaving 5/8" seam allowance. Seam knitted skirt bar to bar and sew lining on the sewing machine with the wrong side facing you.



•Complete outfits for work, out-on-the town and more
•Six skirts and tops
•Charted for two yarns
\$17.95 - Book
\$12.00 - Accompanying Disk

•G-Carriage Sweaters
•Easy pleated skirt
•Mens polo shirt
\$17.95 - Book
\$12.00 - Accompanying Disk

Selected additional titles by Jan Wold and Jan Mills:

Charting With Your Calcuknit	\$15.95
Going Places - Knitting Techniques	\$15.95
Going Places - Garter Carriage	\$17.95
Going Places - Ribber Skirts & Tops	\$15.95
Going Places in Cardigans-Standard	\$15.95
Going Places in Cardigans - Bulky	\$15.95



TUCK STITCH PULLOVER

YARN: Ice Cream

SIZES:

8/10 (12/14) [16] {18/20}

AMOUNT:

Sizes 8-16: 2 lb.

Size 18/20: 2 1/2 lb.

KIT PRICE:

Size 8-16: \$58.00

Size 18/20: \$72.00

TENSION:

Tuck: T 8

Rib: T 3/3 I

GAUGE:

Tuck: 6.17 Sts, 12.37 Rs = 1"

Rib: 9.8 Sts, 8.9 Rs = 1"

Make on any standard Electronic or Punch Card machine with Ribber. Pattern is #238 in Compuknit Pattern Book.

BACK: CO 124 (130) [136] [150] Sts. for K1/P1 Rib. After selvedge RC 0. T 3/3 I. Knit to R 36. Transfer RB Sts. to MB. RC 0. T 8. Begin Tuck Stitch Pattern. Knit to R 142 (148) [[154]] and place a YM on each side for armhole. Continue in tuck pattern to R 260 (272) [[284]]. Mark center 48 [(50)] [52] Sts. for neck opening. Knit 1 R to the left manually for loose tension and BOLT.

FRONT: Knit front same as back up to R 230 (242) [[254]] where neckline shaping begins. Place the center 18 [(20)] (22) Sts. in HP. Place all Sts. to the left in HP and note ndl position and pattern row. Complete right side first. *On neckline edge BO every row 2 Sts. 3 x and EOR 1 St. 9 x. At R 260 (272) [[284]] BO remaining shoulder Sts. Reset RC to 230 (242) [[254]], turn pattern back to proper row. Reset ndls for pattern and complete neckline

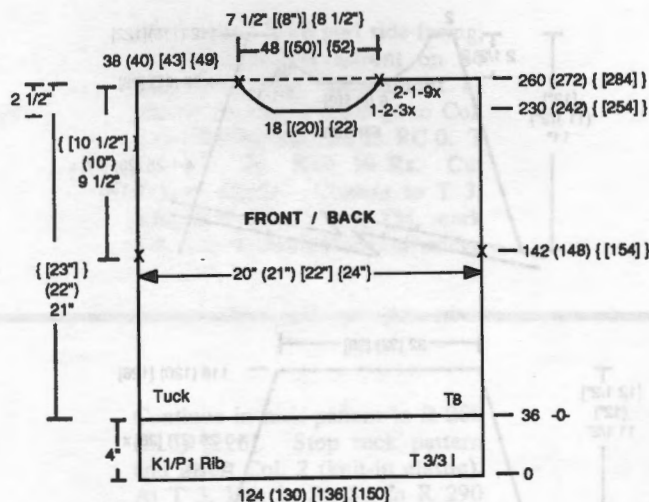

edge from * reversing shapings. Remove center neckline Sts. on WY.

SLEEVE: CO 78 (80) [[88]] Sts. for K1/P1 Rib. After selvedge RC 0. T 3/3 I. Knit to R 30. Transfer RB Sts. to MB. Reset RC to 0. T 8. Knit in tuck pattern incr. on each side of sleeve every 9 Rs. 1 St. 20 x (every 8 Rs. 1 St. 14 x, every 9 Rs 1 St. 8x) [every 9 Rs 1 St. 21 x]. At R 184 (190) [[196]] BO.

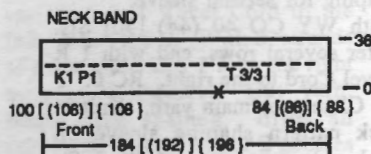
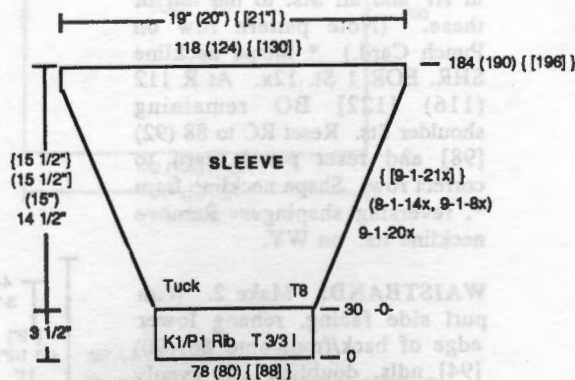

Pattern #238
Compuknit III & IV
Pattern Book
12 sts 66 rows

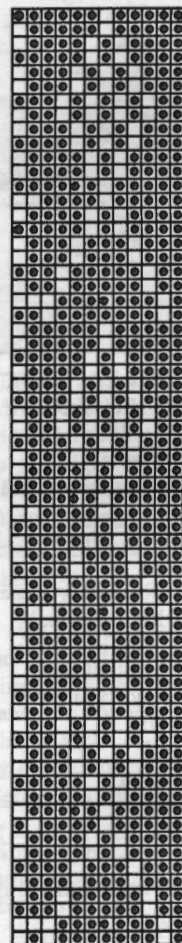

NECKBAND: CO 184 [(192)] [196] Sts. for K1/P1 Rib. T3/3 I. Knit to R 36. Place a YM to mark shoulder seam. (See chart). At T 6/6 I, knit 1 R to the left. Transfer RB Sts. to MB and BOLT.

FINISHING: Close one shoulder. Attach collar. Collar folds to the purl side of garment. Garment is worn on the purl side. Close all seams.

847

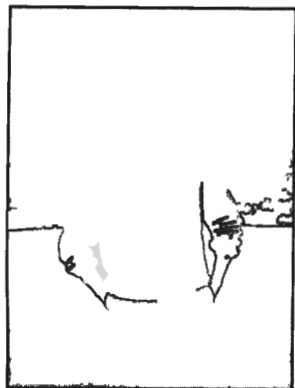

MENS BULKY TUCK RAGLAN PULLOVER

YARN: Venetia
(2 strands throughout)

SIZES:
Small Med Large

AMOUNT:
Col. 1 - Raspberry Venetia
2 lbs. (all sizes)
Col. 2 - Knit in Elastic
1 spool all sizes

KIT PRICE: \$54.00

TENSION:
Tuck: T 4
Rib: T 1/1 I

GAUGE:
Tuck: 4.8 Sts., 10 Rs = 1"

Make on Punch Card Bulky with Ribber.

Note: Sweater worn on the purl side. Length will drop 1-1 1/2". Use 2 strands of yarn throughout.

BACK: With WY CO 100 (104) [110] Sts. After several rows end with 1 row Ravel Cord to the right. Change to main yarn (2 strands). T 4. RC 0. Knit in tuck pattern to R 126 (130) [134] and begin armhole shaping. On each side BO 4 (5) [5] Sts. Reset RC to 0. Continue shaping raglan on each side by decr. every 3 Rs 1 St. 4x all sizes, and every 4 Rs 1 St. 26 (27) [28] x. At R116 (120) [126] remove on WY.

FRONT: Knit front same as back up to R 126 (130) [134]. Begin armhole shaping. RC 0. On each side BO 4 (5) [5] Sts. Continue shaping raglan decr. on each side every 3 Rs 1 St. 4 x (all sizes), every 4 Rs 1 St. 25 (26) [27] x. At the same time begin neckline shaping at R 88 (92) [98]. Place center 6 (6) [10] Sts.

40

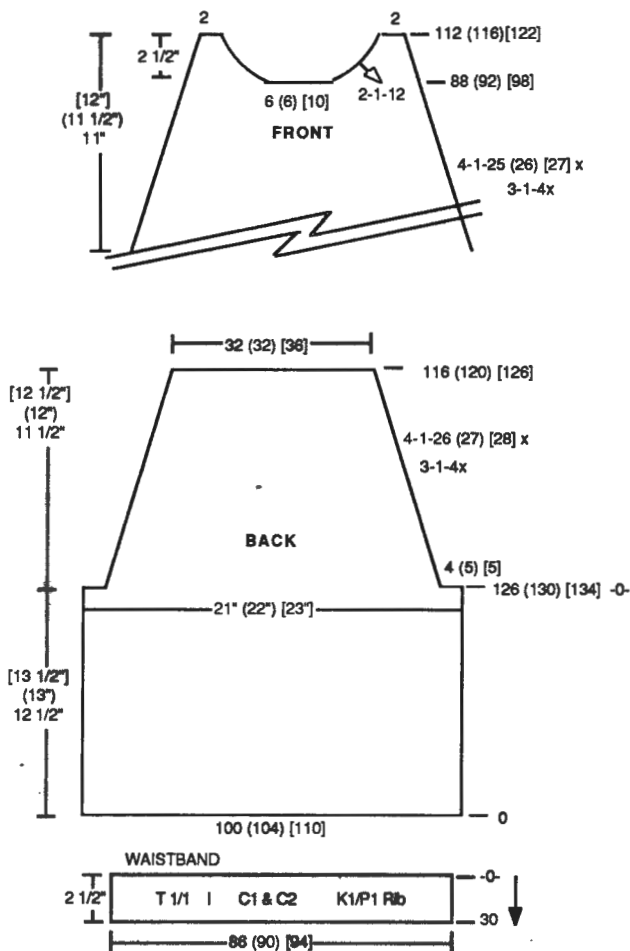

in HP and all Sts. to the left of these. (Note pattern row on Punch Card.) * Shape neckline SHR. EOR 1 St. 12x. At R 112 (116) [122] BO remaining shoulder Sts. Reset RC to 88 (92) [98] and reset punch card to correct row. Shape neckline from *, reversing shapings. Remove neckline sts. on WY.

WAISTBAND: Make 2. With purl side facing, rehang lower edge of back/front onto 86 (90) [94] ndls, doubling sts. evenly across. With Col. 1 and Col. 2, knit 1 R to the left. Transfer EOS to RB for K1/P1 Rib. T 1/1 I. RC 0. Knit 30 Rs, knitting last R at T 8/4. Ending with carr. on left, transfer RB Sts. to MB and BOLT.

SLEEVE: Make 2, reversing shaping for second sleeve. With WY CO 40 (44) [50] Sts. After several rows, end with 1 R Ravel Cord to the right. RC 0. T 4. Change to main yarn. Knit in tuck pattern shaping sleeve on each side incr. every 6 Rs 1 St.

11x, every 7 Rs 1 St. 10 x (every 6 Rs 1 St. 5x, every 7 Rs 1 St. 16x) [every 7 Rs 1 St. 21x]. At R 140 (146) [150], begin raglan shaping. RC to 0. On each side BO 4 (5) [5] Sts. Continue shaping raglan decr. on right side every 3 Rs 1 St. 4 x (all sizes), and every 4 Rs 1 St. 26 (27) [28]x. Decr. on left side every 3 Rs 1 St. 4 x (all sizes) and every 4 Rs 1 St. 25 (26) [27] x. At R 112 (116) [120] begin SHR shaping EOR 5 Sts. 3 x (5 Sts. 3 x) [7 Sts. 1x, 6 Sts. 2x]. At R 116 (120) [126] remove Sts. on WY.

CUFF: With purl side facing rehang lower edge of sleeve onto 36 (36) [40] ndls., doubling evenly across. With Col. 1 (2 strands) and Col. 2, knit 1 R to the left. Transfer EOS to RB for K1/P1 Rib. T 1/1 I. RC 0. Knit to R 24, knitting last row to the left at T 8/4. Transfer RB Sts. to MB and BOLT.

Tuck Pattern

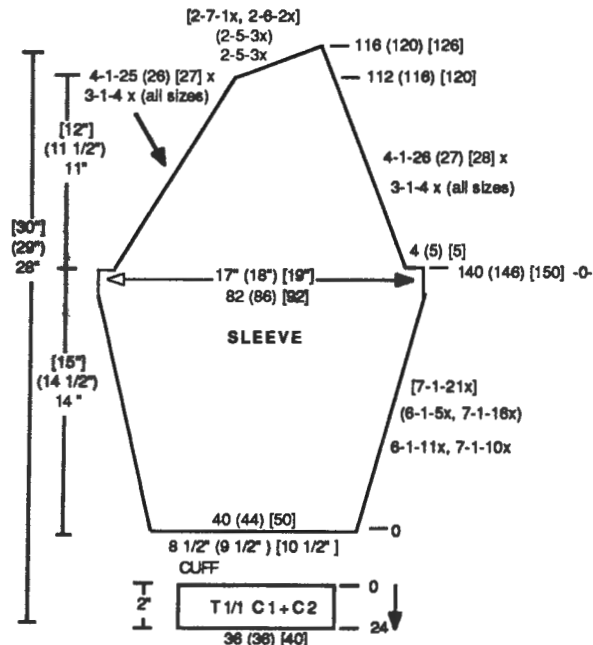
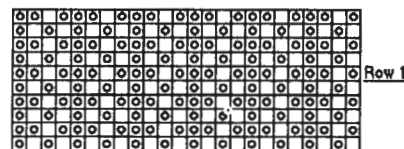

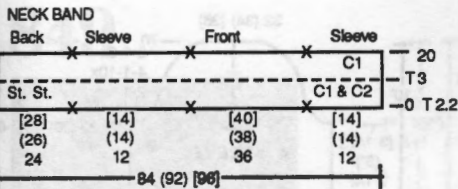

NECKBAND: Close 3 sections of raglan together. Leave 1 back

seam open. With purl side facing, rehang back/sleeve/front on 84 (92) [96] ndls. (placement as shown on chart). Change to Col. 1 (2 strands) and Col. 2. RC 0. T 2.2. St. St. Knit 10 Rs. Cut knit-in elastic. Change to T 3. Knit to R 20. With a YM, mark Sts. for back/sleeve/front/sleeve

on both top and bottom for matching in finishing. Remove on WY.

FINISHING: Close all seams. Fold neck band with knit side showing. Finish on Lectrolink or back stitch in each stitch for finish.

848



2-PIECE DRESS WITH TUCK SKIRT

YARN:
Venetia - Pink

SIZES:
8 (10/12) [14]

AMOUNT:
Col. 1: Venetia
2 cones
(cones approx. 1 1/2 lb. each)
Col. 2: Knit-in Elastic-1 spool
Col. 3: Rubane- 1 Ball
Col. 4: Roma - Olive -1 oz.

KIT PRICE: \$85.00

TENSION:

Top: St. St., T 6

Skirt: Tuck, T 4

GAUGE:

Top: 4.61 Sts., 6.36 Rs. = 1"

Skirt: 5 Sts., 10 Rs. = 1"

Make on Punch Card Bulky Machine.

SKIRT BACK/FRONT:

Knit 2.

Note: Skirt worn on the purl side. Length will drop 1-1 1/2" after hanging. Use 2 strands of yarn for skirt.

With WY CO 102 (106) [110] Sts. After several rows, end with 1 row Ravel Cord to the right. RC 0. T 4. With main yarn knit in tuck pattern to R 100 and mark each side with YM for aid in seaming.

Continue in tuck pattern to R 200 (210) [220]. Stop tuck pattern and insert Col. 2 (knit-in elastic). At T 3, knit in St. St. to R 290 (300) [310]. Remove Sts. on WY.

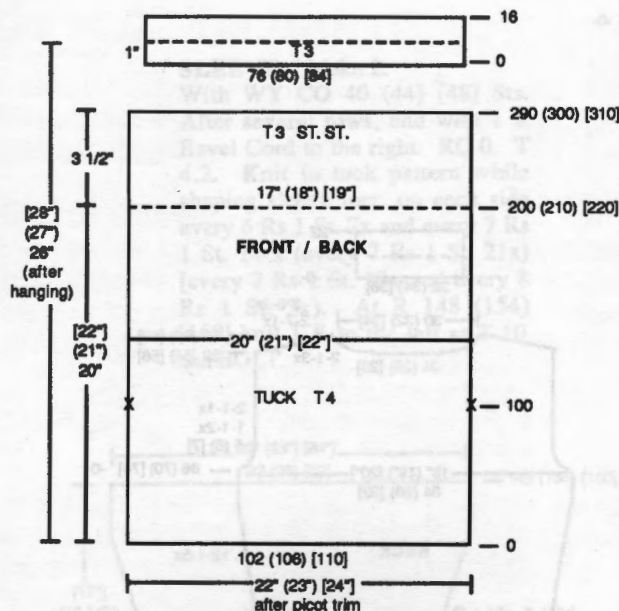

WAISTBAND: Knit 2.

With knit side facing rehang upper edge of skirt on 76 (80) [84] ndls, decreasing evenly across. With 2 strands of main yarn, at T 3. knit in St. St. for 16 Rs. Pick up Sts. from first row to double band. Knit 1 R at T 10 and BOLT.

TOP FRONT: With WY CO 74 (78) [82] Sts. After several rows end with 1 R Ravel Cord to the left. T 6. RC 0. With 3 strands of main yarn knit 1 R to the right across all needles. Cut yarn. Begin SHR shaping. Bring all ndls to HP except center 2 needles (all sizes). To shape SHR on both

sides at same time follow step-by-step instructions:

At RC 0, 2 center ndls in WP.

Step 1: On side closest to carr (right), move 1 needle to WP (the needle to the right of -0-). On opposite side (needle to the left of -0-) push remaining number of ndls needed to complete SHR instructions to WP. Knit 1 R across.

Step 2: On side closest to carr. push 1 ndl back to WP and wrap ndl to eliminate hole (ndl to left of -0-) and on opposite side of carr (ndls to right of -0-) push remaining number of ndls needed to complete SHR instructions to WP.

As shaping continues, you will always move 1 ndls to WP on side closest to carr. and remaining needles in shaping to WP on side opposite of carr. (Example: 1-4-10x = 1 st. to WP on side of carr and 3 Sts. to WP on side opposite carr). *Instruction for SHR will be given for total number of Sts. increased each row. Remember to divide shaping on either side as described above.*

To begin SHR shaping on lower edge of top SHR incr. every row 3 Sts. 10 x all sizes, every row 4 Sts. 10 (11) [12] x and every row 2 sts. 1 x all sizes. At R 21 (22) [23] SHR shaping is completed. Reset RC to 0. Continue knitting in St. St. while shaping sides by incr. on each side every 12 Rs 1 St. 5 x. At R 66 (70) [74] begin armhole shaping. Reset RC to 0. On each side BO 5 (6) [7] Sts. Continue shaping armhole by decr. every row 1 St. 2 x, and EOR 1 St. 1 x. Continue in St. St. to R 44 (46) [48] where neckline shaping begins. *Place center 18 (20) [22] Sts. in HP and all sts. to the left of these in HP. SHR (continued next page) 41

(continued from previous page)

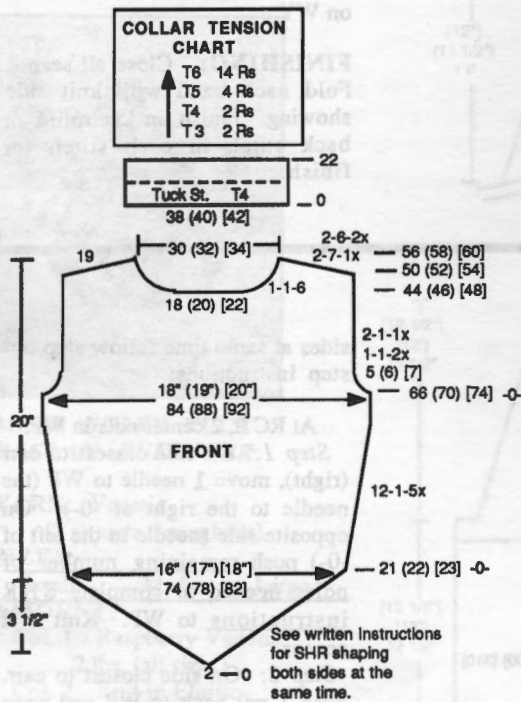

shape neckline every row 1 St. 6 x all sizes. At R 50 (52) [54] begins shoulder SHR shaping EOR 7 Sts. 1 x and EOR 6 sts 2 x for all sizes. At R 56 (58) [60] remove shoulder Sts. to WY. Turn RC back to 44 (46) [48] and shape left edge of neckline and shoulder by reversing shapings from *. Continue with collar.

Collar Front: Use 2 strands of main yarn for collar.

With purl side facing, pick up front neckline sts., plus additional sts. along neck edge on each side for seaming for a total of 38 (40) [42] sts. Knit in tuck as follows:

- T3 - 2 R
- T4 - 2 R
- T5 - 4 R
- T6 - 14 R

Knit 1 R in St. St. at T 10. Remove on WY.

TOP BACK: With WY CO 74 (78) [82] Sts. After several rows, end with 1 row Ravel Cord to the right. Change to main yarn - 3 strands. RC 0. T 6. Knit in St. St. while incr. shaping on both sides every 12 rows 1 St. 5 x for all sizes. At R 66 (70) [74] begin armhole shaping. Reset RC to 0. On each side BO 5 (6) [7] Sts. Continue shaping armhole by decr. every row 1 St. 2 x, and EOR 1 St. 1 x. Continue in St. St. to R

52 (54) [56] where neckline shaping begins. *Place center 24 (26) [28] Sts. in HP and all sts. to the left of these in HP. SHR shape neckline EOR 1 St. 3 x all sizes. AT THE SAME TIME begin shoulder SHR shaping EOR 7 Sts. 1 x and EOR 6 sts 2 x for all sizes. At R 58 (60) [62] remove shoulder Sts. to WY. Turn RC back to 52 (54) [56] and shape left edge of neckline and shoulder from * by reversing shapings. Continue with collar.

Collar Back: Knit back collar same as front, using 2 strands, picking up neckline sts. plus 1 additional st. on each side for a total of 32 (34) [36] sts. Continue as in front collar. Close seams. See instructions below for picot trim.

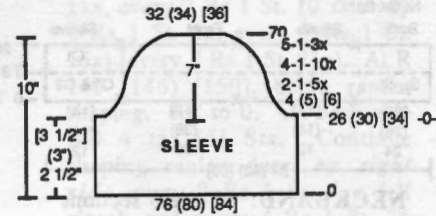

SLEEVE: With WY CO 76 (80) [84] Sts. After several rows, end with 1 row Ravel Cord to the right. Change to 2 strands of main yarn. T 4. RC 0. Knit in Tuck Pattern to R 26 (30) [34]. Reset RC to 0. Begin sleeve cap shaping. On each side BO 4 (5) [6] Sts. Continue shaping on each side by decr. EOR 1 St. 5 x, every 4 Rs 1 St. 10x, and every 5 Rs 1 St. 3 x for all sizes. Knit last row at T 10 (R 70) and mark center St. with YM. BOLT.

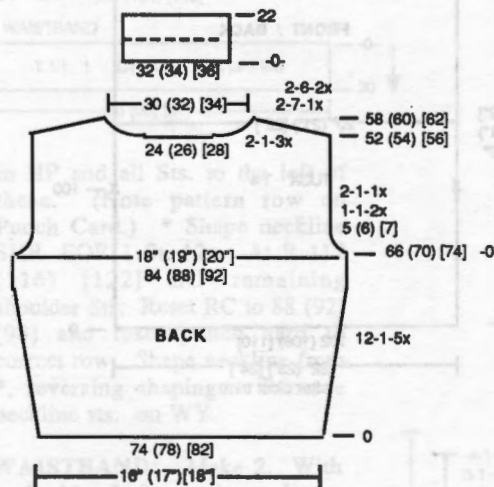

Garment #848
Tuck Pattern for Skirt, Sleeve and Collar

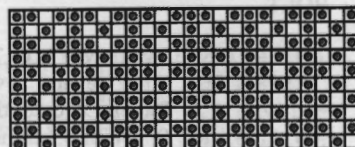

KNITTED ROSE BUD APPLIQUE TRIM:

T 4.2. e' CO 2 Sts. Incr. 1 St. on Carr. side EOR until 8 Sts. Knit 2 Rs. Decr. in full fashion every row by doubling st. #1 on each side of -0- for each decr. until 4 Sts. remain. Pull yarn end through all 4 Sts. Leave ends at beginning and end of bud long enough to attach to front bodice only. Use Fray Check (available in fabric and craft stores) to keep Rubane ends from fraying. After buds are in place, use 4 strands of Olive Roma yarn and overstitch several time to create "leaf bud" look.

FINISHING:

Top: On lower bodice, join side seams. With purl side facing, use 3 Strnds on main yarn and single crochet 1 R around lower edge. **Sleeve:** Gather sleeve cap and close seams. Picot on lower edge same as collar. **Skirt:** Join seams. Picot trim on lower edge same as collar and sleeve.

Picot Trim: Single crochet in first 2 Sts. *Chain 2. Slip stitch in first chain (Picot). Single crochet in next 2 Sts. and repeat from *.



MENS DROP SHOULDER TUCK PULLOVER

YARN: Panache-Wedgewood
(3strands throughout)

SIZES: Small (Med) [Large]

AMOUNT: 3 cones all sizes
(cones approx. 1 lb. each)

KIT PRICE: \$43.50

TENSION:

Tuck: T 4.2

Rib: T 0/0 I

GAUGE:

Tuck: 3.75 Sts., 9.36 Rs = 1"

Make on Punch Card Bulky with Ribber.

BACK: With 3 strands of main yarn, CO 82 (86) [90] Sts. for K1/P1 Rib. After selvedge RC 0. T 0/0 I. Knit to R 32. Reset RC to 0. Transfer RB Sts. to MB. T 4.2. Tuck Pattern. Knit in tuck stitch to R 96 (102) [108] and mark each side with YM for armhole. Continue in pattern to R 190 (200) [210] where SHR shaping begins. On each side SHR EOR 5 St. 5 x for all sizes. Mark center 30 (32) [34] Sts. with a YM for neck opening and remove on W.Y.

FRONT: Knit front same as back up to R 168 (178) [188] where neckline shaping begins. Place center 8 (10) [12] Sts. in HP and all Sts. to the left of these. (Note pattern row on Punch Card.) *Shape neckline SHR. EOR 1 St. 11x. At R 190 (200) [210] begin SHR shoulder shaping same as back. At R 200 (210) [220] remove shoulder Sts. on WY. Reset RC to 168 (178) [188] and reset punch card to correct row. Shape neckline from *, reversing shapings. Remove neckline and shoulder on WY.

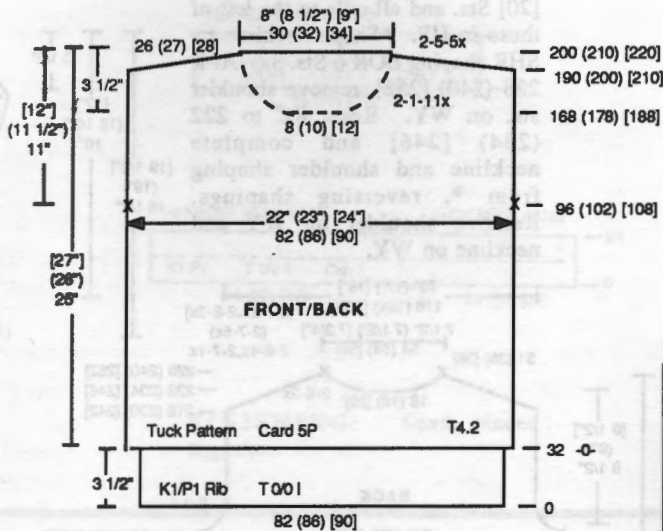

Garment #849
Tuck Pattern

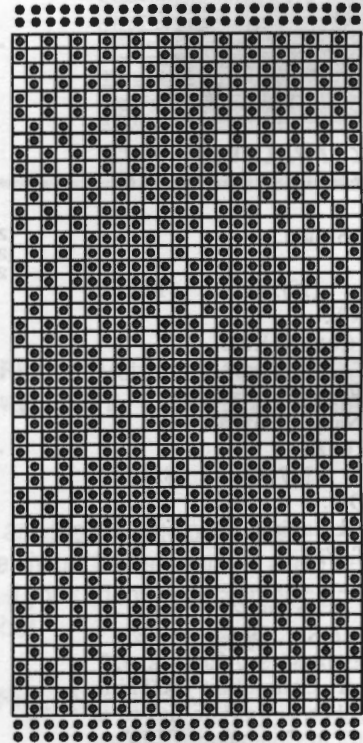

SLEEVE: Make 2.

With WY CO 40 (44) [48] Sts. After several rows, end with 1 R Ravel Cord to the right. RC 0. T 4.2. Knit in tuck pattern while shaping sleeve incr. on each side every 6 Rs 1 St. 7x and every 7 Rs 1 St. 14 x (every 7 Rs 1 St. 21x) [every 7 Rs 1 St. 18x and every 8 Rs 1 St. 3x]. At R 148 (154) [160] knit 1 R to the left at T 10 and BOLT.

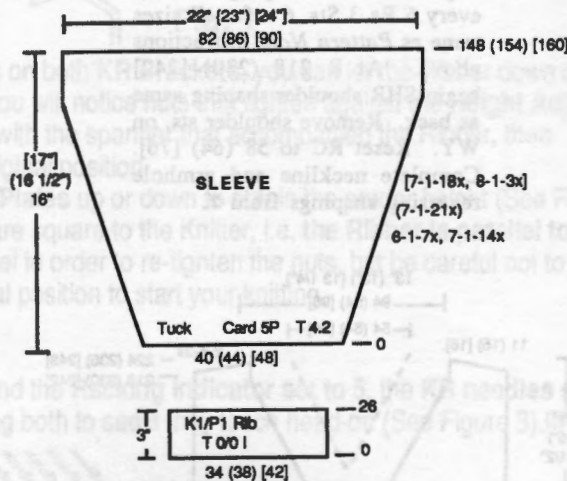

NECKBAND: Close one shoulder. With main yarn (3 strands) CO 92 (96) [100] St. for K1/P1 Rib. After selvedge RC 0. T 0/0 I. Knit 20 Rs. Transfer RB Sts. to MB. With knit side facing, rehang back/front as shown on chart. Knit 1 R at T 10 and BOLT. Fold neckband in half to inside and whip stitch.

CUFF: With main yarn (3 strands) CO 34 (38) [42] Sts. for K1/P1 Rib. After selvedge RC 0. T 0/0 I. Knit to R 26. Transfer RB Sts. to MB. With knit side facing, rehang lower edge of sleeve on these Sts. decr. evenly across. Knit 1 R at T 10 and BOLT.

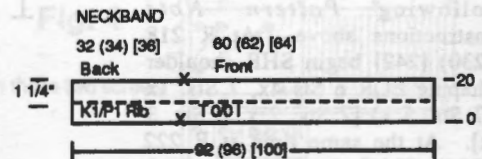

FINISHING: Close all seams. 43



V-NECK PULLOVER WITH FAIRISLE INSET COLLAR

YARN: Softon

SIZES:

6/8 (10/12) [14/16]

AMOUNT:

Col. 1: Cottage Rose
1 lb. (1 lb. 2 oz.) [1 lb. 4 oz.]
Col. 2: Ecru - 3 oz. all sizes
Col. 3: Navy - 1 oz. all sizes

KIT PRICE:

\$25.00 (\$27.00) [\$29.50]

TENSION:

St. St. & Fairisle: T 6

Rib: T 1/1 I

GAUGE:

St. St.: 14.46 Sts., 22.86 Rs = 2"
Rib: 24.6 Sts., 29.34 Rs = 2"
Fairisle: 14:54 St., 20.57 Rs=2"
Made on Compuknit machine with Ribber. Fairisle Inset is Pattern 62 in Compuknit III/IV.
Pattern Note: Armhole shaping on garment body and sleeve cap decreases are done in full-fashion style by picking up end 5 sts. and moving in 3 sts. This leaves end 2 Sts. single and next 3 Sts. in from edge doubled at each decr. This will result in full-fashioned detailing when seamed.

BACK: With Col. 1, CO 152 (160) [168] Sts. for K1/P1 Rib. After selvedge, RC 0. T 1/1 I. Knit to R 44. Set RC to 0. Transfer RB Sts. to MB. T 6. Knit in St. St. to R 122 (128) [134] where armhole shaping begins. On each side BO every 6 Rs 3 Sts. 6 x for all sizes following *Pattern Note* instructions above. At R 218 (230) [242] begin SHR shoulder shaping EOR 6 Sts 4x, 7 Sts. 1x (7 Sts. 5 x) [7 Sts. 2 x, 8 Sts. 3 x]. At the same time at R 222 (234) [246] begin back neck shaping. Place center 16 (18)

[20] Sts. and all ndls to the left of these in HP. *Shape neckline by SHR shaping EOR 6 Sts. 3x. At R 228 (240) [252], remove shoulder sts. on WY. Reset RC to 222 (234) [246] and complete neckline and shoulder shaping from *, reversing shapings. Remove shoulder on WY and neckline on WY.

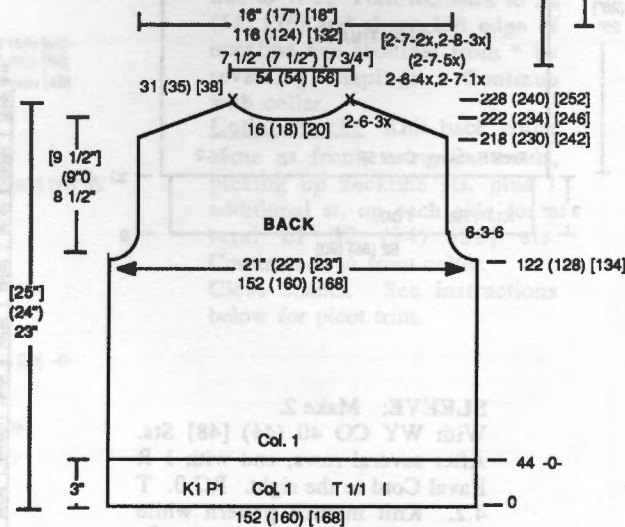

FRONT: Knit front same as back up to R 58 (64) [76] where v-neck shaping begins. Place all Sts. to the left of -0- in HP and begin neckline shaping by *decr every 3 Rs 1 St 32 (26) [30] x and every 4 Rs 1 St. 15 (21) [18] x. AT THE SAME TIME at R 122 (128) [134] begin armhole shaping. Decr. every 6 Rs 3 Sts. 6 x for all sizes same as *Pattern Note* instructions above. At R 218 (230) [242] begin SHR shoulder shaping same as back. Remove shoulder sts. on WY. Reset RC to 58 (64) [76]. Complete neckline and armhole reversing shapings from *.

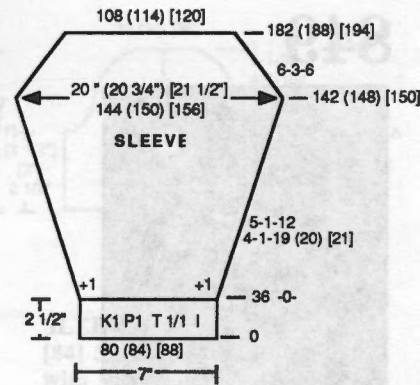
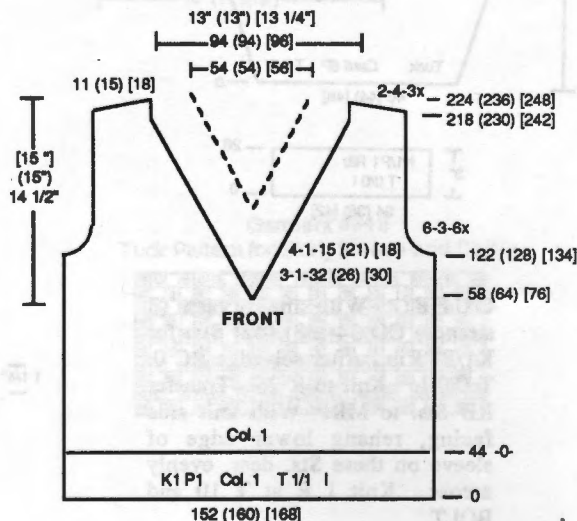

SLEEVE: Make 2.

With Col. 1, CO 80 (84) [88] Sts. for K1/P1 Rib. After selvedge, set RC 0. T 1/1 I. Knit to R 36. Transfer RB Sts. to MB. T 6. RC 0. On each side, incr. 1 St. Knit in St. St. incr. on sides every 4 Rs. 1 St. 19 (20) [21] x and every 5 Rs. 1 St. 12 x for all sizes. At R 142 (148) [150] begin shaping for sleeve cap. Decr. every 6 Rs. 3 St. 6 x for all sizes following *Pattern Note* instructions. Knit last R at T 10 and BOLT at R 182 (188) [194].

FAIRISLE NECK INSET: Make 2, reversing shapings.

With purl side facing, pick up sts. from front left neckline edge. With K-Carr on left, T 6. Col. 2 in "A" feeder, knit 1 R to the right, setting ndls for fairisle pattern (Pattern #62 in Compuknit III/IV) RC 0. Place Col. 3 in "B" feeder and knit 4 Rs fairisle. Replace C3 with Col. 1 and continue fairisle, shaping right miter corner beginning decr. shaping at R 4. Decr. EOR 1 St. 16 x. At R 32, change to Col. 3 in "B" feeder and knit 4 Rs. End of fairisle. Knit 1 R (R 37) with Col. 3 only and remove Sts. on WY.

NECKBAND:

Make in 2 sections.

Section One: One-half of front.

Close one shoulder first. With purl side facing rehang front edge of neckline onto 84 (90) [90] Sts., decr. evenly across. RC 0. T 6. Knit 1 R to the left. Transfer every other St. to RB for K1/P1 Rib. T 1/1 I. Knit 2 Rs. Begin miter shaping. Incr. EOR 1 St. 5 x. At R 12 begin reverse miter shaping. Decr. EOR 1 St. 5 x. Knit 2 Rs. Transfer RB Sts. to MB. Pick up Sts from first row to form doubled band. Knit 1 R at T 10 and BOLT.

Section Two: Back and one-half front. Rehang open back neckline Sts and remaining front neckline edge sts. on 138 (144) [146] Sts. decr. along front neckline same as Section One. Knit Section Two same as Section One reversing side that is mitered. (See chart).

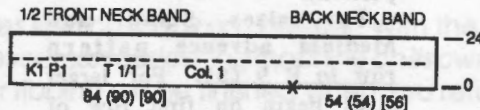
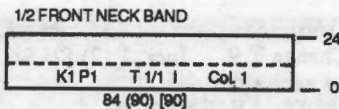

FINISHING: Seam pieces together.

Fairisle Neck Insert
Pattern #62 - CompuKnit Pattern Book
22 Sts., 30 Rows

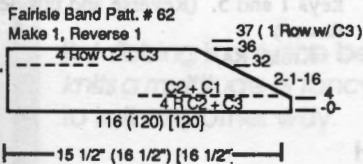
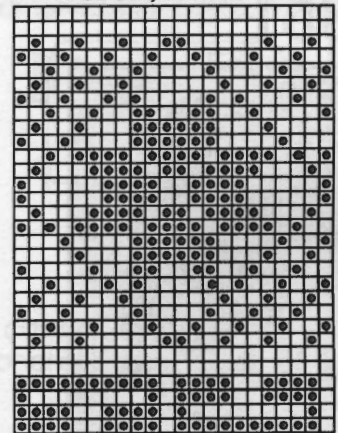

knitting technical tips

Although not a common occurrence, there is occasionally the need to adjust the position of the Ribber in relation to the Knitter. There are really only two areas where adjustments can be made: the distance between the Ribber (we'll call it "KR") and the Knitter (which we'll call "KH") and the position of the Ribber needles.

Distance between the Ribber (KR) and the Knitter (KH):

Whereas no clearance is required between the back of the KR needles, when fully extended, and the KH gate pegs, there is a desired clearance between the back of the KH needles and the KR gate pegs. This distance should be between 0.7 and 1.3mm (See Figure 1). This just so happens to be the approximate thickness of a credit card. Hence, if you cannot slide a credit card into this gap so that it fits just snugly, you will need to make an adjustment in the height of the Ribber.

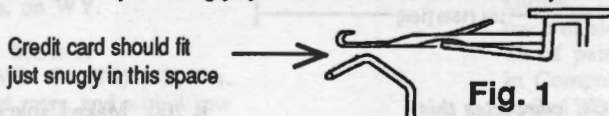

Fig. 1

- 1) By pushing down the levers on both KR Brackets, you can let the Ribber down one level. At the back of the Ribber, you will notice nuts that tighten against the Height Adjuster Plates. Loosen these nuts with the spanner that accompanied the Ribber, then raise the Ribber up to its original position.
- 2) Move the Height Adjuster Plates up or down to obtain the proper height (See Figure 2). Make sure that both sides are square to the Knitter, i.e. the Ribber is parallel to the Knitter. When you have succeeded, let the Ribber down one level in order to re-tighten the nuts, but be careful not to over-tighten. You can then raise the Ribber back up to its original position to start your knitting.

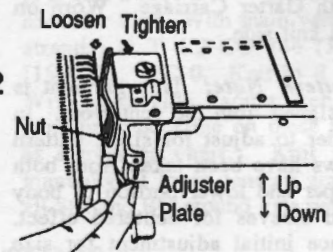

Fig. 2

Position of Ribber Needles:

With the Half-Pitch Lever set to P, and the Racking Indicator set to 5, the KR needles should be exactly opposite the KH needles. Confirm this by extending both to see if they touch head-on (See Figure 3). If they do not, you will need to adjust them by the following:

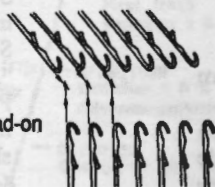
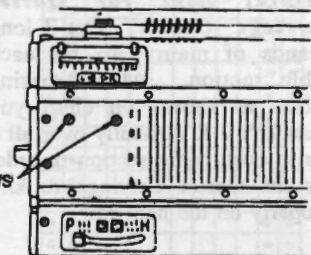

Fig. 3

Fig. 4

Loosen these two screws



- 1) Loosen the two screws which are beside the "D" mark on the left side of the KR needle bed (See Figure 4).
- 2) Shift the whole needle bed left or right until the KR and KH needles meet head-on.
- 3) After adjusting, fasten the two screws tightly

851

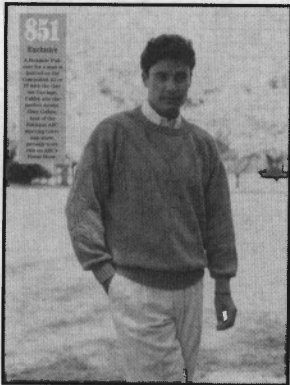

MENS GARTER CARRIAGE AND CABLE PULLOVER

YARN: Venetia - Salmon
(2 strands throughout)

SIZES:
Small (Med) [Large]

AMOUNT:

2 cones all sizes

KIT PRICE: \$68.00

TENSION:

Body: T 9

Rib: T 4.2

GAUGE:

Body: 7.06 Sts., 10.59 Rs = 1"

Make on Compuknit III/IV knitter with Garter Carriage. Worn on the knit side.

Pattern Note: This garment is designed from the center out. In order to adjust for sizes, pattern rows have been taken from both upper and lower portion of body and sleeves for centered effect. Once initial adjustment for size has been made on garment body, all cable crosses and track changes occur at the same pattern row and row counter number. Read instructions carefully before beginning. A suggested technique is to prepare a "cheat sheet" in advance listing every row where cable crosses, increases, etc will be worked.

Helpful Hint for Garter Carriage Cables: Cut 2 long strands of main yarn for each cable section. After crossing cables as shown on chart you must knit 1 R manually over all 8 Sts in each cable section in order for the Garter Carriage to knit properly on the next row.

BACK: 2 strands of main yarn.
T 4.2. Garter Carr. CO 154 (158)

46

[166] Sts. Knit 36 Rows.
Change T 9. Incr. 1 (2) [2] Sts.
on each side.

IMPT: RC 8 (4) 0.

Set pattern from first track of pullover (contains lower portion).

For sizes Small and Medium advance pattern row to R 9 (5). For larger sizes begin on first row of pattern.

Knit 38 (42) 46 Rs.

Knit 12 Rs.

R 150: Make Cable crosses.

Knit 14 Rs.

R 164: Make Cable cross.

Knit 27 Rs. (Note: RC should be at 1 - completed track counted backwards)

Change back to first track of pattern and activate variation keys 1 and 5. (Reverse and upside down).

Knit 9 Rs.

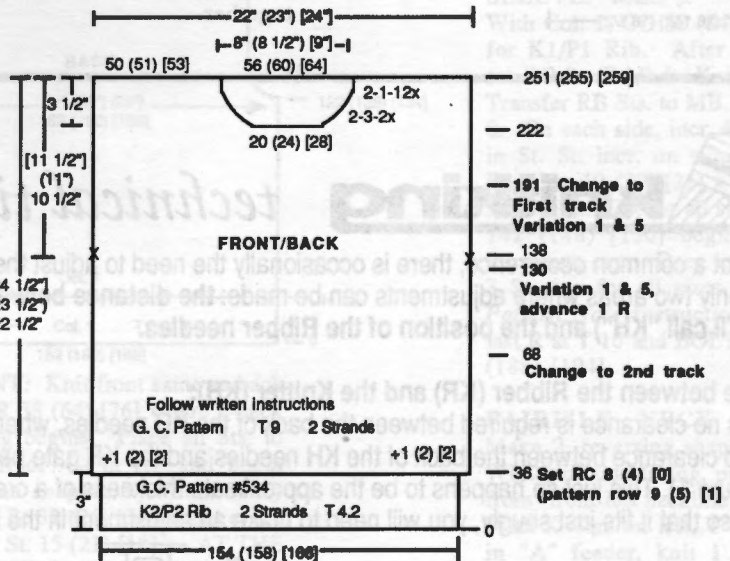

Note: When GC completes this section, RC and Pattern Row number should be at 46 for all sizes.

R 46: Make cable cross

Knit 14 Rs

R 60: Make cable cross

Knit 8 Rs. (Note: RC and Pattern row number should be 68 for all sizes)

Change to second track of pattern.

Set GC to knit 28 rows.

R 96: Make cable crosses.

Knit 14 Rs

R 110: Make cable crosses.

Knit 14 Rs.

R 124: Make cable crosses.

Knit 6 Rs. (RC 130, Pattern Row 62).

Reset pattern, using variation keys 1 and 5 (reverse and upside down). Advance pattern one row to avoid repeating pattern row 62.

Knit 6 Rs.

R 136: Make cable cross.

Knit 2 Rs.

R 138: Mark each side with YM for armhole (all sizes).

R 200: Make Cable cross.

Knit 14 Rs.

R 214: Make Cable cross.

Knit 37 (41) [45] Rs.

RC should be at 251 (255) [259]. Mark center 56 (60) [64] Sts. with YM for neck opening and BO around gate pegs.

FRONT: Knit front same as back to R 200 and begin to follow instructions below:

R 214: Make Cable cross

Knit 8 Rs.

R 222: Knit center 20 (24) [28] Sts. to non-working "A" position manually on Ravel Cord. Knit all Sts. to the left of center Sts. to "A" position on Ravel Cord. Press "M" to mark row in memory. *Begin neckline shaping BO EOR 3 Sts. 2 x and decr. EOR 1 St. 12 x for all sizes. Continue in pattern to R 251 (255) [259] and BO shoulder. Return all Sts. (except center 20 (24) [28] to WP. RC 222. Return to proper pattern row. Shape neckline from *, reversing

THE GARTER CARRIAGE KNITS RIBBING AUTOMATICALLY AND MUCH, MUCH MORE!!

The Knitking Garter Carriage makes knitting Ribbing a breeze. With the press of a button, the Garter Carriage moves across your knitting machine *on its own power!* You can leave the room and your ribbing will be finished when you return!

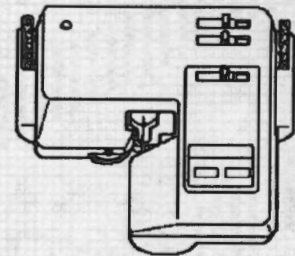

But ribbing is only the beginning of the story: The Garter Carriage *automatically casts on, binds off and knits a multitude of fancy Garter Stitch patterns*—beautiful textured three-dimensional designs impossible to knit any other way.

You merely select your desired pattern on your knitting machine (using the COMPUKNIT III or IV keyboard, the COMPUKNIT II mylar sheets, or the KH 860 - KK 93 punch cards), set the number of rows needed, switch your Garter Carriage on, and leave to do other things. It will switch itself off when a garment section is completed or if the yarn runs out or breaks.

Order your Garter Carriage now from your local Knitking dealer, or if there is none in your area, order from



1128 Crenshaw Blvd., Los Angeles, CA 90019. Phone: 213-938-2077.

shapings. Remove center neckline sts. on WY.

SLEEVE: Make 2.
CO with WY 74 (78) [82] Sts. After several rows, end with 1 row Ravel Cord to the left. Change to main yarn (2 strands). With K-Carr, knit 1 R to the right. Garter Carr. T 9. RC 0. Begin with lower sleeve track starting on pattern row 39 (35) [31]. Incr. on both sides every 4 Rs 1 St. 25 (23) [23] x and every 6 Rs 1 St. 13 (16) [17] x, making cable

crosses every 14 Rs as shaping allows. At R 30 (34) [38] first track of sleeve is complete. (Row 68 of pattern should be flashing in Compuknit window). Change to 2nd sleeve track. Knit to R 92 (96) [100]. Reset same pattern and track, using variation keys 1 and 5 (reverse and upside down). Advance pattern 1 row to avoid repeating last row. Knit to R 153 (157) [161]. Change to first track, using variation keys 1 & 5. At R 182 (190) [198] BO around gate pegs.

NECKBAND: Close one shoulder first. With main yarn (2 strands) at T 4.2 CO 146 (150) [154] Sts. RC 0. Knit to R 30. With purl side facing, rehang front/back neckline on these ndls as shown on chart. Knit 1 R manually at loose tension across all Sts. and BO around gate pegs.

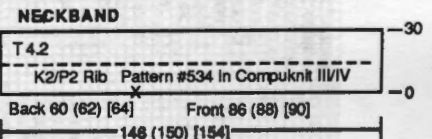

FINISHING: Close all seams. Fold neckband to inside and whip stitch into place.

Cable Chart - 8 Sts - 6 St. Cable

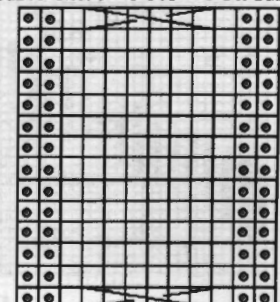

(continued next page) 47

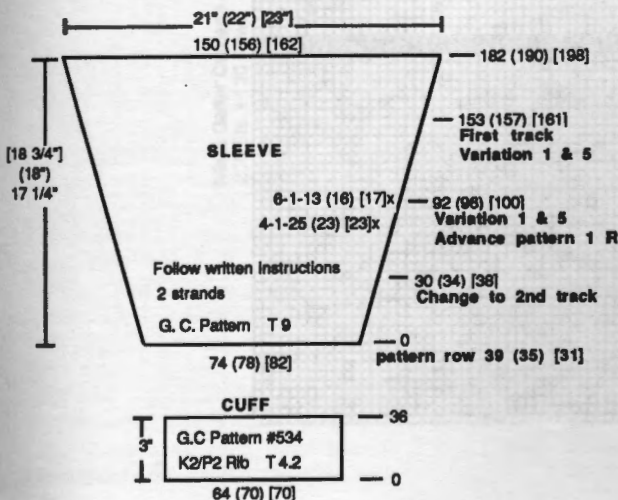

CUFF: With GC CO 66 (70) [70] Sts. at T 4.2, 2 strands of main yarn. Pattern #534 in Compuknit Pattern Book (K2/P2 Rib). RC 0. Knit 36 Rs. With purl side facing rehang lower edge of sleeve on these needles, decreasing evenly across. Knit 1 R to the right at T 10 and BO around gate pegs.

(continued from previous page)

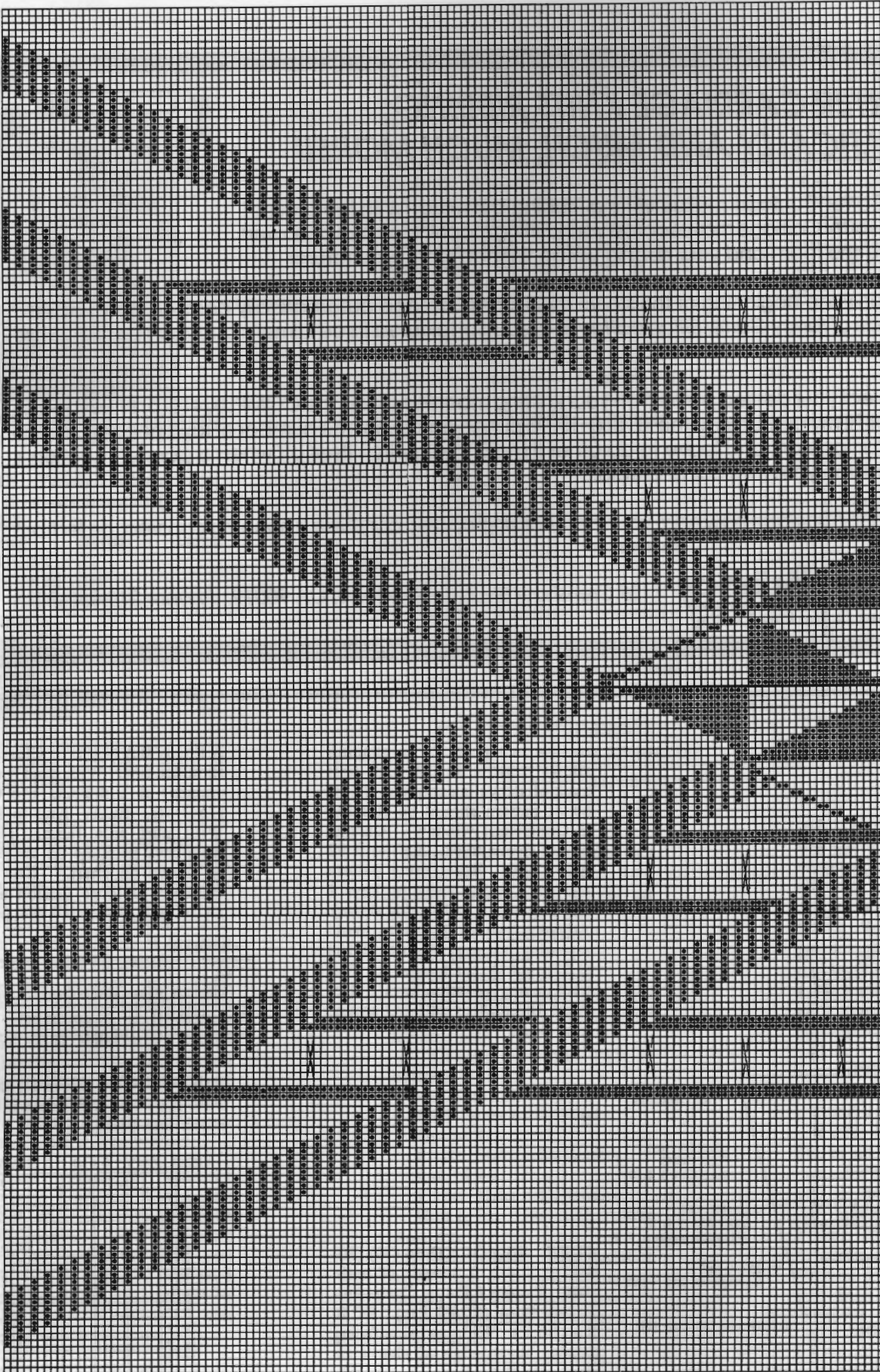

Mens Garter Carriage - Front/Back
200 Stitches x 130 Rows

2nd Track

Mens Garter Carriage - Sleeve
200 Sts. x 130 Rows

2nd Sleeve Track

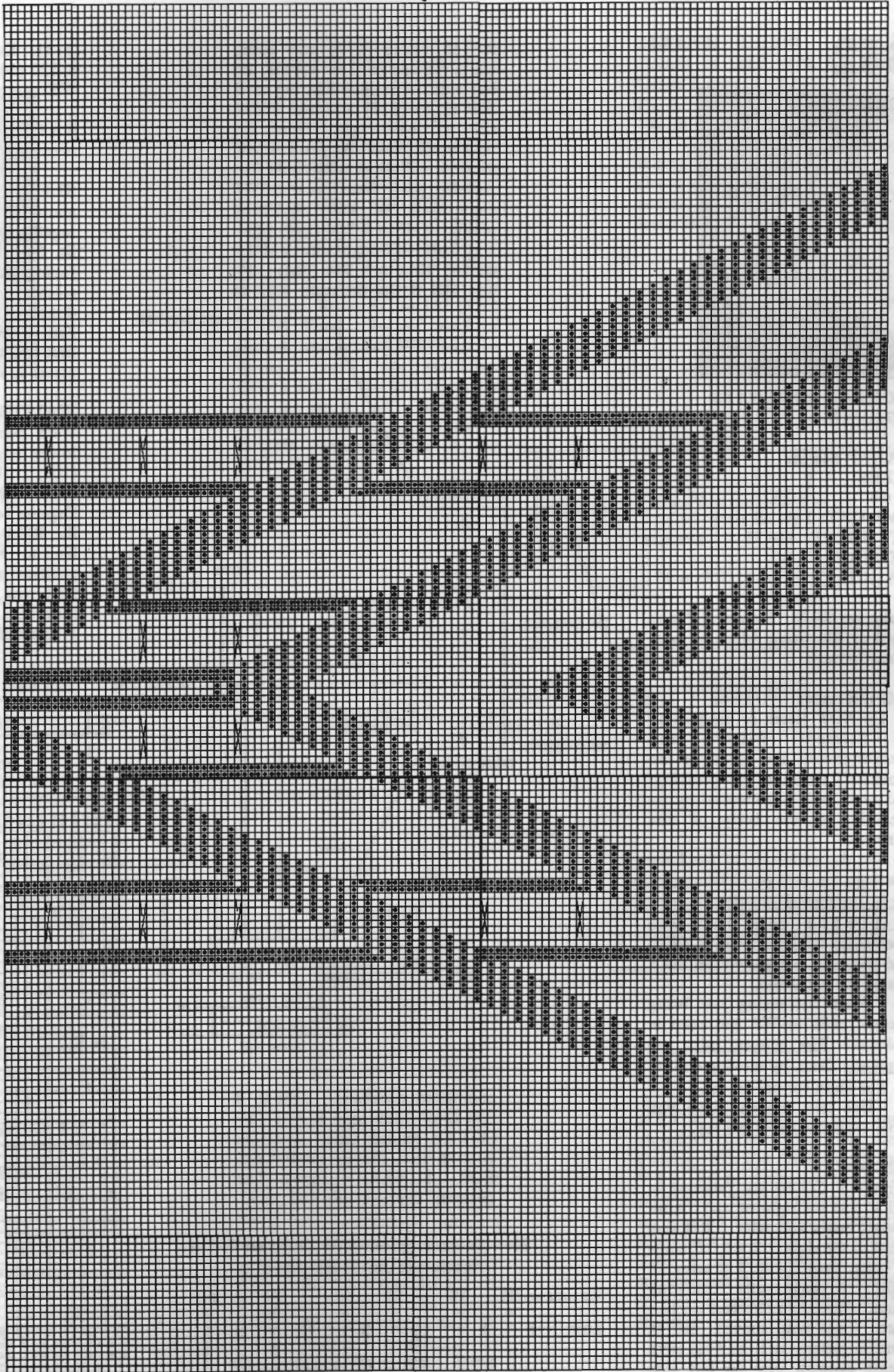

Row 31



WOMENS SIDEWAYS DOLMAN

YARN: Starlite

SIZES: 6/8 (10/12) 14

AMOUNT: 1 lb. all sizes

KIT PRICE: \$16.75

TENSION: T 6.2

GAUGE: 7.18 Sts, 11.7 Rs = 1"

Make on 24-St. Standard Punch Card or Electronic Machine with Lace Carriage.

IMPORTANT NOTES:

1. Do NOT steam or press body of garment. Pattern and measurements are based on no blocking, steaming or pressing. Textured look is enhanced by no steaming to the body of this garment.
2. On the underside of the Lace Carriage the orange kickers must be in horizontal position.
3. Always push back end needles to working position (WP) and the ndls that are within the 8 Sts of the neckband.
4. When increasing just bring the end ndle to WP and keep in pattern. The empty ndls are counted. Decr. by moving end st.
5. See chart for ndl set up.
6. Use any swatch piece you have available for waste rag.

FRONT:

With WY CO 60 Sts. (starting at ndl #26 to the right of -0-). After several rows end with 1 R Ravel Cord to the right. T 6.2. Change to main yarn. Knit 1 R over all ndls. Arrange ndls following chart. (Remember kickers on lace carr. - see note above). RC 0. Knit in pattern to R 37 (43) [49]. Begin dolman incr on left side EOR 1 St. 64 x (all sizes). Knit to 50

R 165 (171) [177] and using waste rag add 26 (34) [42] Sts. on left side. Continue knitting to R 206 (216) [226] and add 8 Sts. (plain) on right side for neckband. Note: As you knit and these 8 additional ndls come into pattern, push them back to WP each time to knit neckband plain). Knit to R 260 (270) [280] and mark left edge with YM for center. Knit to R 314 (324) [334] and BO 8 Sts on right side of

[511]. Knit straight in pattern to R 520 (540) [560] and remove on WY.

BACK: Knit same as front, reversing shapings.

SLEEVE BAND: Seam shoulder and top of sleeves together, then add Sleeve Band. St. St. T 5.2. With purl side facing rehang lower edge of sleeve on 54 (54) [60] ndls. doubling evenly across. RC 0. Knit 20 Rs. Pick ups Sts. from first row to form hem. Knit 1 R across at T 10 and BOLT.

WAISTBAND: With purl side facing rehang lower edge of garment on 108 (108) [118] ndls. St. St. T 5.2. Push EON to "E" position (HP) Depress both part buttons. Knit 1 R. RC 0. Release part buttons. Knit to R39. Push EON to "E" position and pick up Sts. from first row of knitting (EON) to form hem. Knit 1 R to the left at T 10 and BOLT.

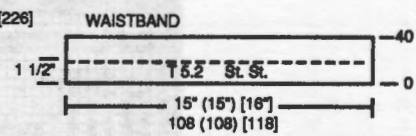
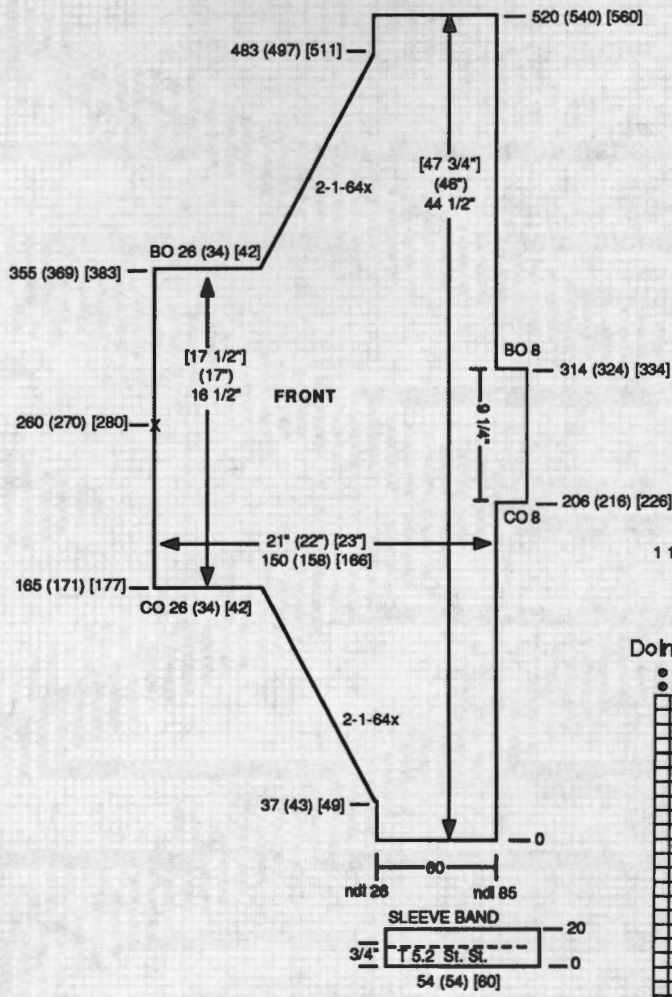

Dolman Pullover - Lace - 24 Sts. 47 Rows

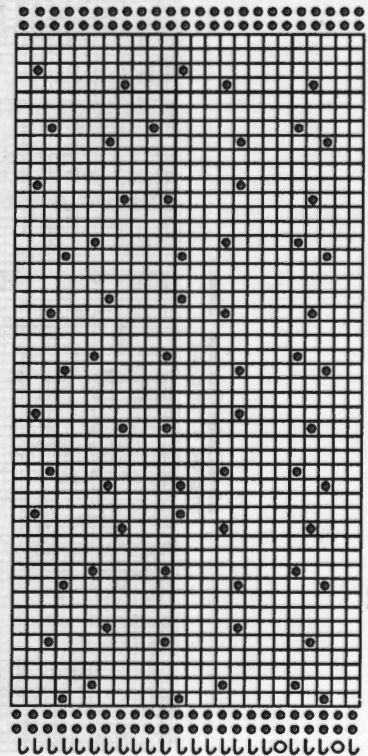

completed neckband. Knit to R 355 (369) [383] and BO 26 (34) [42] Sts on left side. Continue dolman decr. shaping on left side EOR 1 St. 64 x (all sizes). Last dolman decr. at R 483 (497)

Needle Arrangement for Dolman Pattern
Needle Set Up: To the right of -0-

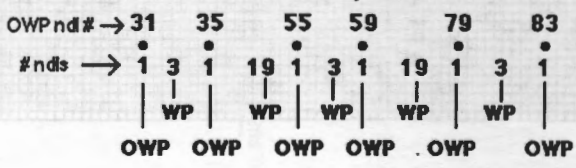

FINISHING: Close all seams.



**GIRLS OVERSIZE
GARTER CARRIAGE
PULLOVER**

YARN: Silkie
(2strands throughout)

SIZES: 6 (8) [10/12]

AMOUNT:
Flourescent Pink
2 cones (2 lb) all sizes

KIT PRICE: \$24.00

TENSION:
Garter Carriage: T 10
Rib: T 7.1

GAUGE:
Garter Carriage: 5.61 Sts.,
9.79 Rs = 1"

Make on Compuknit III/IV with Garter Carriage. Garment is worn on the knit side.

Note: All-over design is 130 Sts wide and 235 Rows in length. Pattern does not repeat. With suggested yarn, tension and gauge, this garter carriage pattern can be knitted up to 23" wide and 24" in length.

Pattern available on Knitting Magazine Floppy Disk. For printout of pattern, send request to Knitking, c/o Magazine Dept.

BACK:
With 2 strands of main yarn, CO 84 (92) [100] Sts. RC 0. T 7.1. Knit to R 14. Change to T 10. Set track for lower portion. Knit to R 90 (98) [108]. **Note:** Remember to change to second track of pattern after R 100. At R 90 (98) [100] BO on each side 2 (3) [3] Sts. Continue to R 172 (186) [200]. **Note:** Remember to change to third track of pattern after R 195 if additional length is required. Mark center 40 (42) [44] Sts. for neck opening with YM. BO around gate pegs.

FRONT: Knit front same as back up to R 142 (156) [170] where neckline shaping begins. Knit center 12 (14) [16] Sts. manually to "A" (out of work) position on Ravel Cord. Knit all Sts. to the left of center Sts. to "A" position on Ravel Cord. **Note pattern row.** Shape neckline. *BO EOR 2 Sts. 2 x, 1 St. 10 x all sizes. At R 172 (186) [200] BO shoulder. **Note:** For larger size third track will be needed for completion of right neckline. Reset RC to 142 (156) [170]. **Note:** Second track of pattern and proper row must be brought back into machine. Return Sts. to the left of center neckline sts. to WP. Shape left neckline same as right from *. Remove center neckline sts. on WY.

SLEEVE CUFF: With 2 strands of main yarn, CO with Garter Carriage 42 (44) [46] Sts. RC 0. T 7.1. K1/P1 Rib (Pattern 532 in Compuknit Pattern Book). Knit to R 14. With purl side facing rehang lower edge of sleeve on these ndls, decr. evenly across. Knit 1 R manually for loose tension and BOLT.

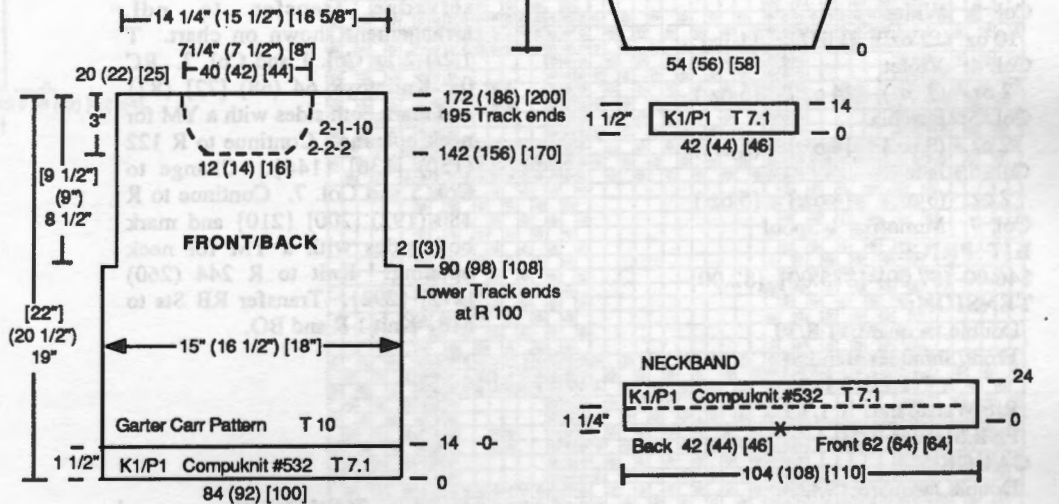

SLEEVE: With WY CO 54 (56) [58] Sts. After several rows end with 1 R Ravel Cord to the left. With 2 strands of main yarn at T 10 knit 1 R St. St. to the right. RC 0. Garter Carriage pattern - track for lower portion of pattern. T 10. Shape sleeve by incr. every 6 Rs. 1 St. 21x (every 4 Rs. 1 St. 4 x, every 6 Rs 1 St. 18x) [every 4 Rs 1 St. 6 x, every 6 Rs 1 St. 18x]. (Note: Remember to change tracks at R 100.) At R 128 (134) [140] BO around gate pegs.

NECKBAND: Close one shoulder first. With Garter Carriage CO 104 (108) [110] Sts. T 7.1. RC 0. Knit to R 24. With purl side facing rehang neck opening on these needles placing front/back as shown on chart. Knit 1 R manually at loose tension and BO. Fold neckband in half to inside and whip stitch in place.

FINISHING: Close all seams. 51



**MULTI-COLOR
DOUBLE-KNIT PULLOVER**

YARN: Pearlyte

SIZES:

6/8 (10/12) [14] {18/22}

AMOUNT:

Col. 1: Red
6 oz. (8 oz.) [10 oz.] {12 oz.}

Col. 2: Black
10 oz. (12 oz.) [1 lb.] {1 lb.}

Col. 3: White
10 oz. (12 oz.) [1 lb.] {1 lb.}

Col. 4: Violet
2 oz. (3 oz.) [4 oz.] {5 oz.}

Col. 5: Fuschia
2 oz. (3 oz.) [4 oz.] {5 oz.}

Col. 6: Jade
2 oz. (3 oz.) [4 oz.] {5 oz.}

Col. 7: Monofil - 1 Spool

KIT PRICE:

\$46.00 (57.00) [\$75.00] {82.00}

TENSION:

Double Jacquard: T 3/3 I

Front/Shoulder Band:

T 1.2/1.2 I

Rib Waistband: T 1/1 I

FNR Sleeve: T 1/1 I

GAUGE:

Double Jacquard:
6.55 Sts., 13.19 Rs = 1"

Front/Shoulder Band:

14 Sts., 11.67 Rs = 1"

Rib Waistband:
11.43 Sts., 12.5 Rs = 1"

FNR Sleeve:
6.37 Sts., 12.76 Rs = 1"

NOTIONS: 7 - 1/2" buttons

Make on Compuknit machine with Ribber and Ribber Color Changer.

Note: Length will drop 1". For double jacquard: Col. 3 in "A" Feeder, Col. 2 in "B" feeder.

BACK: Knit in two double jacquard sections and one back shoulder band.

Double Jacquard Section One:

Col. 3 and Col. 2 as described above.

CO for FNR 68 (72) [76] {82} Sts. After selvedge, RC 0. T 3/3 I. Pattern #58 in Compuknit III/IV. Knit in double jacquard to R 118 (124) {[132]}. Mark left side with YM for armhole. Continue in double jacquard to R 218 (230) {[244]}. Transfer RB Sts. to MB and BO.

Double Jacquard Section Two:

Col. 3 and Col. 2 as described above.

CO for FNR 68 (72) [76] {82} Sts. with ndl #30 on left side. After selvedge, RC 0. T 3/3 I. 40x40 pattern as shown. (Available on Knitting Magazine Floppy Disk). Knit in double jacquard to R 118 (124) {[132]}. Mark right side with YM for armhole. Continue in double jacquard to R 218 (230) {[244]}. Transfer RB Sts. to MB and BO.

Back Shoulder Band: (Make 1)

Cast on 42 Sts. for FNR. After selvedge transfer to ndl. arrangement shown on chart. T 1.2/1.2 I. Col. 1 and Col. 7. RC 0. Knit to R 64 (68) [72] {82} and mark both sides with a YM for neck opening. Continue to R 122 (130) [136] {146}. Change to Col. 5 and Col. 7. Continue to R 180 (192) [200] {210} and mark both sides with a YM for neck opening. Knit to R 244 (260) [272] {292}. Transfer RB Sts to MB. Knit 1 R and BO.

**Shoulder Band Front/Back
Needle Chart**



**BACK SHOULDER
BAND
Make 1**

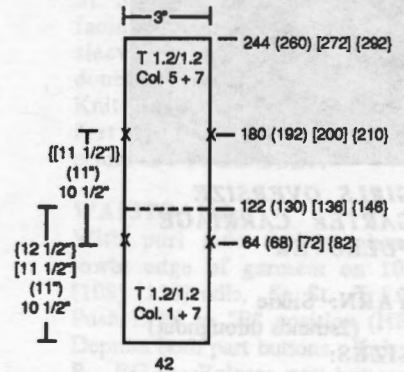

FRONT: Knit in two double jacquard sections, two shoulder bands and two front bands.

Double Jacquard Section One:

Knit same as Back Section One, except CO 60 (64) [68] {76} Sts.

Double Jacquard Section Two:

Knit same as Back Section Two, except CO 60 (64) [68] {76} Sts. starting at ndl #22 on left.

Front Band: Make 2. 1-Col. 1 & 7; and 1-Col. 6 & 7.

CO 36 Sts. for FNR. After selvedge arrange ndls as shown on chart. RC 0. T 1.2/1.2 I. Knit to R 130 (140) {[152]} and mark right side with YM for opening. Continue to R 200 (210) {[222]}. Transfer RB Sts to MB. Knit 1 R and BO. Make second band using other color.

Front Shoulder Bands: (Make 2)

1-Col. 1 & 7; 1-Col. 4 & 7.

Cast on 42 Sts. for FNR. After selvedge transfer to ndls arrangement shown on chart. T 1.2/1.2 I. Col. 1 and Col. 7. RC 0. Knit to R 64 (68) [72] {82} and mark both sides with a YM for neck opening. Continue to R 134 (138) [146] {158}. Transfer RB Sts to MB. Knit 1 R and BO.

Make second band using other color.

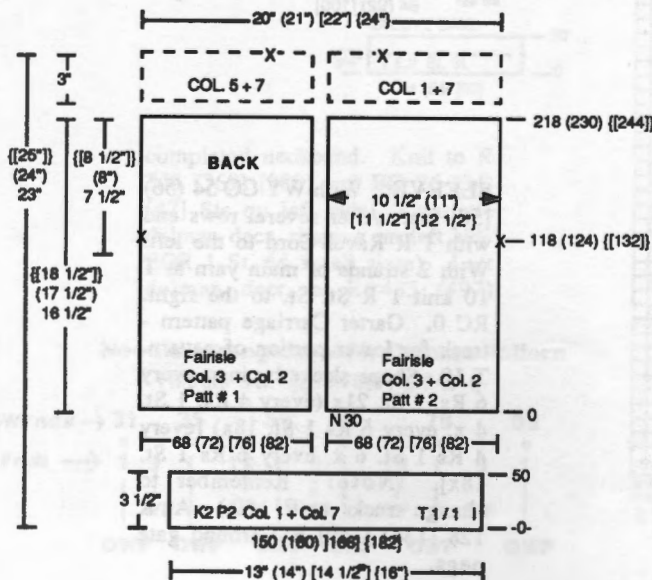

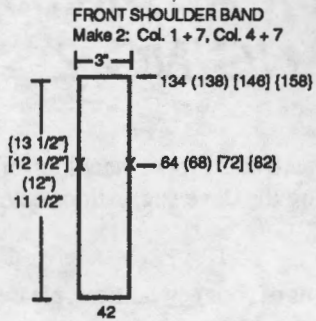

WAISTBAND: Make 2.
Seam pieces together as shown on chart.

With Col. 1 & 7, CO 150 (160) [166] [182] Sts. for K2/P2 Rib. After selvedge RC 0. T 1/1 I. Knit to R 50. Transfer RB Sts. to MB. With purl side facing rehang lower edge of front/back on these ndls, decr. evenly across. Knit 1 R manually at loose tension to the left and BOLT.

Garment #854 - Double Jacquard
Pattern #58-Compuknit II/IV 34 Sts. x 28 Rows

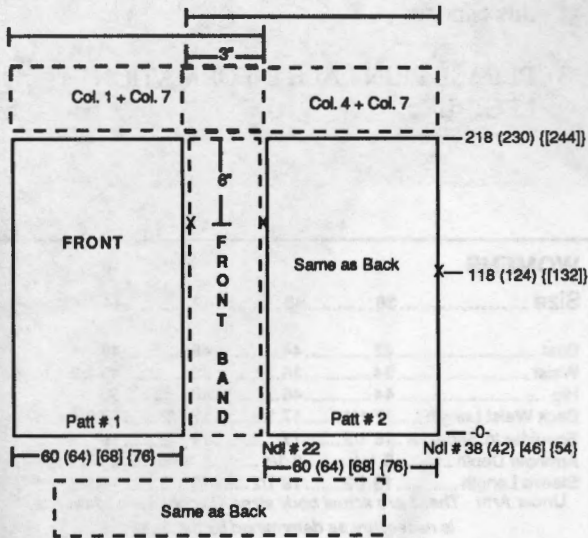
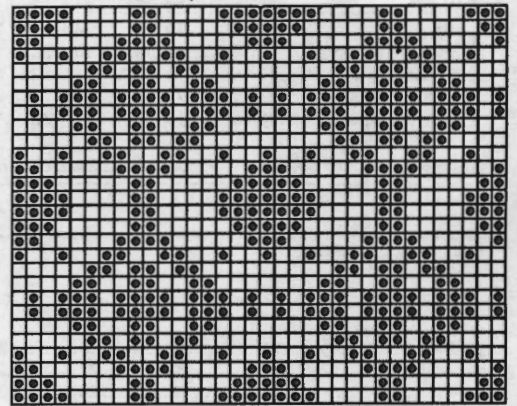

Garment #854 - Double Jacquard 40 Sts. x 40 Rows

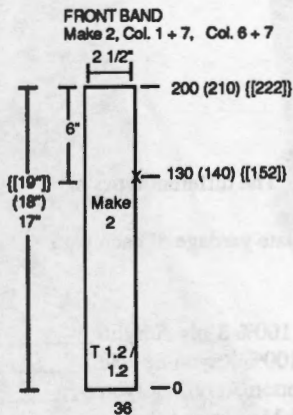
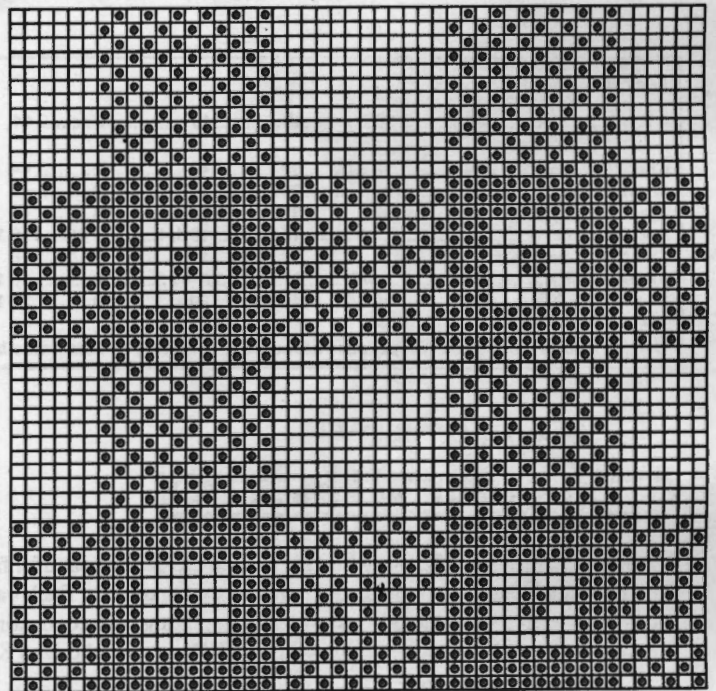

SLEEVE: Make 2, reversing colors as shown on chart.

With Col. 4 CO 114 (120) [[126]] Sts. for FNR. After selvedge RC 0. T 1/1 I. Shape sides by incr. every 12 (13) [[14]] Rs 1 St. 10x. Knit in FNR to R 46 (50) [[54]]. Change Col. Continue to R 60 (64) [[68]]. Change Col. Knit to R 74 (78) [[82]]. Change Col. Knit to R 88 (92) [[96]]. Change Col. Knit to R 128 (134) [[140]]. Transfer RB Sts. to MB. Knit 1 R across all Sts. at T 10 and BOLT. Repeat for second sleeve starting with Col. 1. Follow color changes as shown on chart.

FINISHING: Attach front shoulder bands overlapping center front approximately 1 1/2". Attach back neckband. Attach Sleeves to garment body. Close all seams. Place buttons for decorative finish as shown in photo. Fold sleeve cuff back and stitch in place to hold.

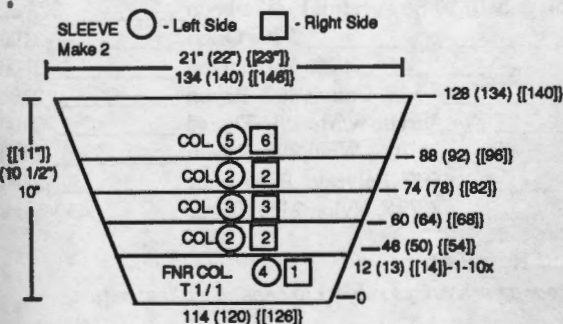

Knitking Sizing Chart

MISSES

Size	6	8	10	12	14	16	18
Bust	30 1/2	31 1/2	32 1/2	34	36	38	40
Waist	22	23	24	25 1/2	27	29	31
Hip	32 1/2	33 1/2	34 1/2	36	38	40	42
Back Waist Length	15 1/2	15 3/4	16	16 1/4	16 1/2	16 3/4	17
Shoulder to Shoulder	13 1/2	13 1/2	14	14 1/2	15	15 1/2	16
Armhole Depth	7	7	7 1/2	7 1/2	7 1/2	8	8
Sleeve Length Under Arm	16 1/2	16 1/2	17 1/2	17 1/2	17 1/2	18	18

These are actual body sizes. Proper ease allowance is necessary as determined by the style.

CHILDREN

Size	12 mo	2 yr	4	6	8	10	12
Chest	19	21	23	25	27	28	30
Waist	19	20	21	22	23	24	25
Hip	20	22	24	26	28	30	32
Back Waist Length	7	8 1/2	9 1/2	10 1/2	12 1/2	14	15
Shoulder to Shoulder	7 1/2	8 1/2	9 1/2	10	11	11 1/2	12
Armhole Depth	3 1/2	4	5 1/2	6	6 1/2	6 1/2	7
Sleeve Length Under Arm	6	7 1/2	9 1/2	10 1/2	12	13 1/2	15

These are actual body sizes. Proper ease allowance is necessary as determined by the style.

Mens

Size	34	36	38	40	42	44
Chest	34	36	38	40	42	44
Waist	30	32	34	36	38	40
Hip	35	37	39	41	43	45
Back Waist Length	15 1/2	15 1/2	16	16 1/4	16 1/4	16 1/4
Shoulder to Shoulder	15 1/2	16	16 1/2	17	17 1/2	18
Armhole Depth	8	8 1/2	9	9 1/2	10	10 1/2
Sleeve Length Under Arm	19	19 1/2	19 1/2	20	20	20 1/2

These are actual body sizes. Proper ease allowance is necessary as determined by the style.

IS YOUR ADDRESS CHANGING ?

If so, you can insure the proper handling of this change by following the three suggestions below:

- 1) When advising us of your new address, please also indicate your old address.
- 2) Please provide us with six weeks notice to affect this change.
- 3) PLEASE PRINT ALL INFORMATION LEGIBLY.

WOMENS

Size	38	40	42	44
Bust	42	44	46	48
Waist	34	36	38	40 1/2
Hip	44	46	48	50
Back Waist Length	17 1/4	17 1/2	17 1/2	17 3/4
Shoulder to Shoulder	16 1/2	17	17 1/2	18
Armhole Depth	8 1/4	8 1/4	8 1/4	8 1/2
Sleeve Length Under Arm	18 1/2	18 1/2	18 1/2	18 1/2

These are actual body sizes. Proper ease allowance is necessary as determined by the style.



The finest quality KNITKING yarns are used to create the beautiful fashions found in KNITKING Magazine.

Kit prices are located with the instructions for each garment. Each yarn comes in a wide selection of colors. The different types of yarns have been selected to allow for blending, mixing, and contrasting—both color and texture.

Yarn Color Book is available through KNITKING or an authorized Knitking dealer. Content and approximate yardage of each yarn is included in the chart below:

	<u>Yds./Pound</u>	<u>Price/Ounce</u>	<u>Yds./Pound</u>
Angora 100% Rabbit Hair (10 gr. ball)	33 yds./ball	Panache 100% 3-ply Acrylic	2400
Angora/Wool 70% Angora/30% Wool	1750	Pearlyte 100% Rayon Boucle	2200
Acrylite 2/12 Acrylic	2400	Pebble Boucle Cotton/Acrylic/Rayon	700
Bright Filler 63% Acrylic/31% Viscose/7% Poly	2400	Primo 100% Mercerized Cotton	2500
Bulkytime 100% Bulky Orlon with slubs	1500	Rayon Nubs 100% Rayon Nub Filler Yarn	5500
Caprinae 78% Mohair/13% Wool/9% Nylon	980	Roma 80% Acrilan/20% Antron	2600
Glace 100% Slinky Bright Rayon	2400	Rubane (50 gr ball) 100% Polyamid 1/8" ribbon	82/ball
Glace Plus 100% Slinky Bright Rayon	1650	Silkie 2-Ply Orlon	2100
Ice Cream 54% Cotton/46% Rayon	2100	Softon 100% Soft Cotton	2000
Lumiyarn Thin Metallic Yarn (50 gr. cone)	1200/cone	Sorbet 54% Cotton/46% Rayon	2200
Mini Acrylite 2/24 Weight 100% Acrylic	3600	Starlite Acrylic w/Metallic Thread	2400
Mini Pebble 100% Rayon Slub Filler Yarn	3350	Venetia 70% Wool/30% Rayon	2400
Mirage 100% 4-Ply Worsted Acrylic	1000	Wings 100% Polyester Filler Fluff	2600
Nordica 100% Australian Wool	1850	Knit-in Elastic 79% Nylon/21% Elastic	430/spool

Yarn Color Book: \$25.00 + Shipping and Handling

Order your Knitking kits in the color of your choice from Knitking color cards. Kit and yarn prices subject to change without notice.

846

All Time Favorite

A perfect complement with pants or a skirt is this Tuck stitch Pullover that is knitted on any Standard or Electronic machine. The wide bands are 1 x 1 ribbing. Ice Cream is the yarn.



847

Country Credits

A great Raglan Pullover is in the same Tuck pattern used for the Women's Skirt 848. The sweater was worn by Gary Collins, the host of the ABC Home Show. Knit it with Venetia on the Punch Card Bulky machine, using the Ribber for the Bands.



848

Delectable

Sugar and Spice and things nice are in this perfect two piece Dress. The top is Stockinette stitch with short row shaping at front edge. The Rosebuds are knitted separately then sewn in place. The sleeves, Collar and Skirt are a Tuck stitch. Knit it with Venetia on the Punch Card Bulky.



849

Essentially His

Any Man will proudly wear this classic Pullover that is quickly knitted in a Tuck stitch Design on the Punch Card Bulky. The bands are 1 x 1 ribbing and you knit it with Panache.



850

Casual Chic

A beautiful Pull-over is knitted in Stockinette with a Fair Isle Inset to accent the flattering 'V' neckline. Knit it with our Softon on the Compu-knit III or IV with Ribber for the bands.



851

Exclusive

A fantastic Pull-over for a man is knitted on the Compuknit III or IV with the Garter Carriage. Cables add the perfect accent. Gary Collins, host of the National ABC morning television show, proudly wore this on ABC's Home Show.



852

Lacy Delight

Very new, very different, very textured is a lovely Pullover that is knitted sideways on any Standard or Electronic machine with a Lace Carriage. The bands are Stockinette stitch and the yarn is Starlite.



853

Oversized For Fun

All girls love the big, floppy sweaters and this is a perfect choice for your Special Girl. Knit it on the Compuknit III or IV with our Garter Carriage using two strands of Silkie.



854

On The Wild Side

Great Colors, great Designs all seem to flow together when you seam the separate sections together. It's an outstanding Pullover that is knitted in double Jacquard on a Standard or Electronic machine with Ribber. Pearlyte is the yarn.



**Announcing the finest selection of quality yarns—
with simply the best prices and support
available anywhere...**

 **yarns by**
knitking
The First Name in Machine Knitting



Unsurpassed Selection and Quality

With over 25 different yarns and over 250 different colors in the Knitking line, you have a variety to choose from for any and all needs. The yarns include a wide selection of natural fibers and blends, along with acrylics and acrylic blends in varying weights. There are fine filler yarns for blending, elastic for knitting in and a wide array of colors and textures in all types.



Unsurpassed Support



No yarn company in the world can match Knitking's support for its customers. For 25 years, Knitking has published the internationally-acclaimed **Knitking Magazine**. Each quarterly full-color issue contains at least 20 original fashions *made exclusively with Knitking Yarns*, complete with clear instructions for machine knitting.

And At Prices Well Below The Competition

Order the exciting Knitking Yarn Book today for only \$25.00 from your local Knitking Dealer, or if you do not have one in your area, from:



1128 Crenshaw Blvd., Los Angeles, CA 90019 • Phone (213) 938-2077