

KH840 SUPPLEMENTARY SERVICE MANUAL

INDEX

DISASSEMBLING THE CARRIAGE	1
ASSEMBLING THE CARRIAGE	5
SINGLE MOTIF MECHANISM	10
CAM BUTTON AUTO RESET MECHANISM ..	11
END NEEDLE SELECTION MECHANISM	12
HOW TO ADJUST THE CARRIAGE	14
MEASUREMENT OF CARRIAGE CAM	14
CHECKING THE CARRIAGE FUNCTIONS	15

- NOTE:**
1. Please use this supplementary sheet with KH830 service manual.
 2. The difference between KH840 and KH830 is the carriage only. Other part is similar mostly.

DISASSEMBLING THE CARRIAGE

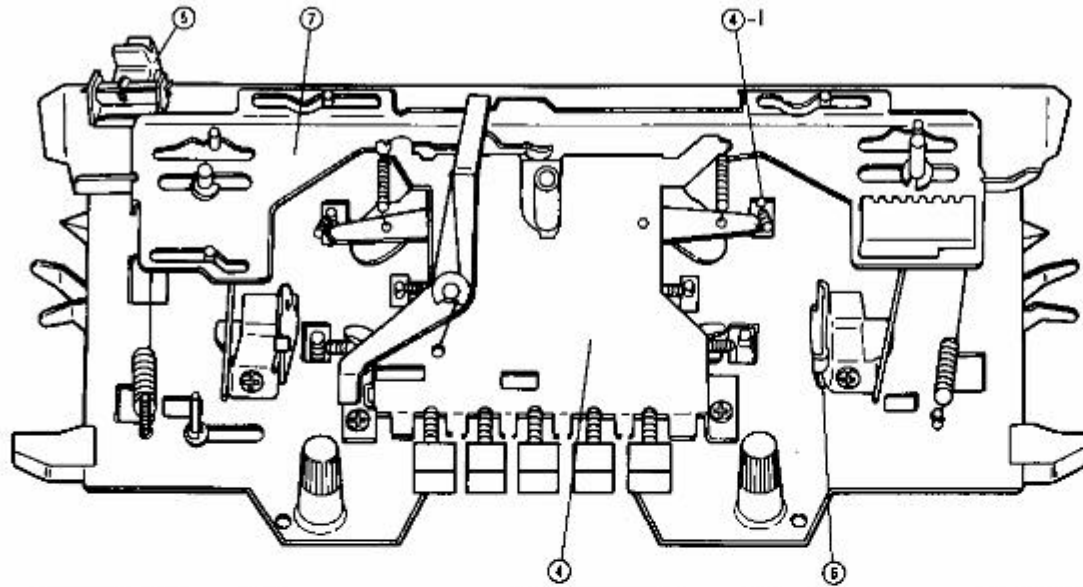

Fig. 1

Name of parts

- ① Cam button unit
- ①-1 Raising cam change spring
- ② Row counter tripper
- ③ Handle setting base
- ④ Upper slide plate

1. Removing the carriage handle

1.1 Keep the handle down and remove the two right and left handle screws. Then the handle can be taken off the carriage.

2. Removing the stitch dial

2.1 Pull off the stitch dial cap upward.
2.2 Remove the fastening screw and pull off the stitch dial upward.

3. Removing the carriage cover

3.1 Loosen, from the back of the carriage, and remove the two right and left carriage cover clamp screws.
3.2 Pull off the carriage cover upward. Then the H.C.L. knob, the plain lever knob and the change knob will come off.

4. Removing the cam button unit

4.1 Remove the raising cam change spring by means of a work hook used from the side of the raising cam calking pin.
4.2 Remove the two cam button unit clamp screws.
4.3 Remove the cam button unit by lifting it while pulling it toward you.

5. Removing the row counter tripper

5.1 Loosen from the back of carriage and remove the two row counter tripper screws, then pull off the tripper upward.

6. Removing the handle setting base

6.1 Remove the two right and left clamp screws and then the leaf spring.
6.2 Remove the two right and left clamp screws.

7. Removing the upper slide plate

7.1 Remove the snap rings from the change knob shaft and left side shaft using a — screw driver.
7.2 Remove the upper slide plate by lifting its right and left ends at the same time.
7.3 Then S.M. cam change crank will be removed.

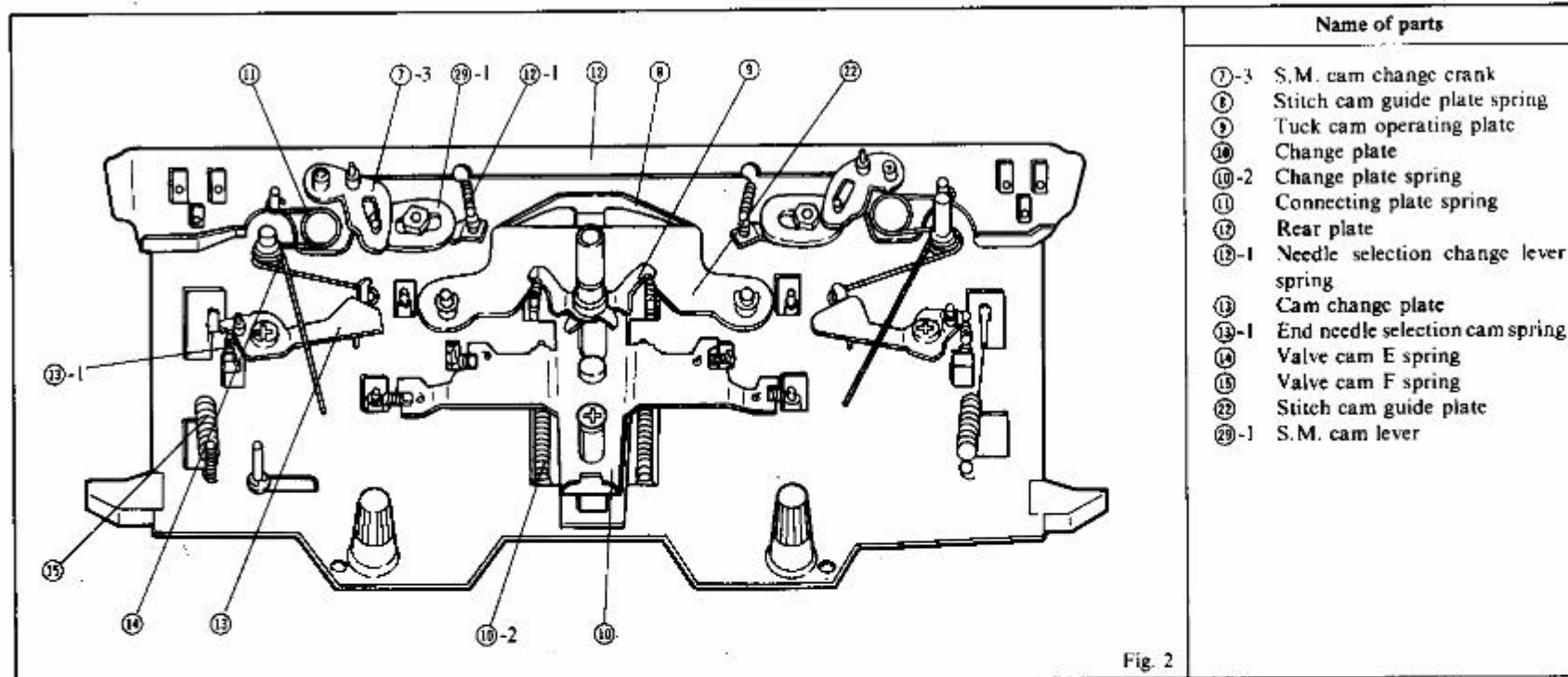

Fig. 2

8. Removing the stitch cam guide plate spring

8.1 Remove the stitch cam guide plate spring by pressing this center toward the stitch cam guide plate.

9. Removing the tuck cam operating plate in left and right

9.1 2 springs of tuck cam operating plate will be removed at the place of calking.

9.2 Lift and pull off the presser ring and the tuck cam operating plate.

10. Removing the change plate

10.1 Remove the four right and left MC cam springs from the MC cam.

10.2 Remove the right and left ends of the change plate spring from the change plate.

10.3 Remove the nuts from the change plate clamp screws using a box driver from the back of the carriage.

10.4 Remove the change plate clamp screw(s) with a driver. Lift and pull off the plate.

11. Removing the connecting plate spring

11.1 Lift and pull off the two springs on the left and right.

12. Removing the carriage rear plate

12.1 Remove the needle selection change lever spring from the rear plate and the rear plate will come off.

13. Remove the cam change plate

13.1 Remove the end needle selection cam spring R,L from the selection cam for R,L end needle.

13.2 Remove the cam change plate clamp screws.

14. Remove the valve cam E spring

15. Remove the valve cam F spring

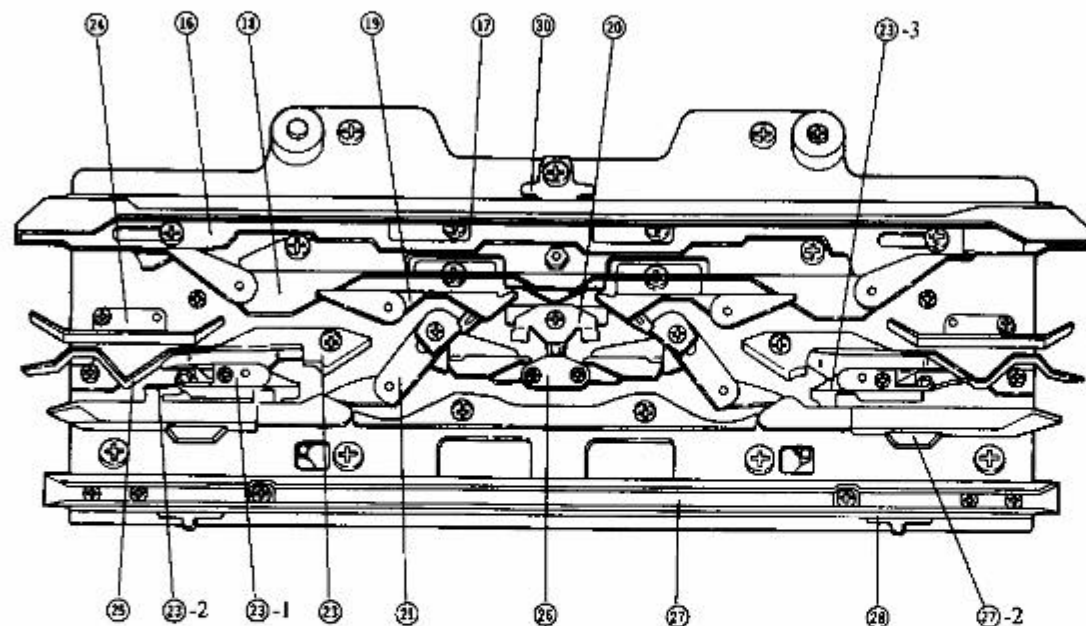

Name of parts

- ①⑥ Front slide plate
- ①⑦ Front foot
- ①⑧ Guide cam A
- ①⑨ Guide cam B
- ②⑩ Guide cam C
- ②⑪ Stitch cam
- ②⑫ Selection cam
- ②⑬-1 Guide cam G
- ②⑬-2 Valve cam F
- ②⑬-3 Needle selection change cam
- ②⑭ Guide cam F
- ②⑮ Separation cam
- ②⑯ Tuck cam
- ②⑰ Rear foot
- ②⑱-2 Selection cam for end needle (original type)
Selection guide for end needle (2nd, 3rd type)
- ②⑲ Connection plate
- ③⑰ Stripe adjuster plate

Fig. 3

16. Remove the front slide plate

- 16.1 Remove the H.C.L. spring.
- 16.2 Remove washer put on the H.C.L. knob shaft on the outer side of the carriage.
- 16.3 Remove the two front slide plate stud screws. Then lift and pull off the front slide plate. (When pulling off the plate, keep the H.C.L. knob at position H.)

17. Removing the carriage front foot

- 17.1 Remove the two carriage front foot clamp screws and then the foot itself.

18. Removing guide cam A

- 18.1 Remove the two right and left guide cam A clamp screws and then the cam itself. (Slide cam as well)

19. Removing guide cam B

- 19.1 Remove the left guide cam B clamp screw and then the left section of the cam.
19.2 Remove the right section in the same manner.

20. Removing guide cam C

- 20.1 Remove the guide cam C clamp screw, and guide cam C, valve cam C, the valve cam C spring, guide cam C shaft, slide cam guide and clamp screw will come off.

21. Removing the stitch cam

- 21.1 Remove snap ring from the stitch cam shaft on the outer side of the carriage.
21.2 Remove the nut from the sub stitch cam using a box driver from the outer side of the carriage (See Fig. 3)
21.3 Remove the left stitch cam clamp screw, and the left part of valve cam D, the left part of the valve cam D spring, the sub stitch cam, the sub stitch cam shaft (collar), the left part of the MC cam and the clamp screw will come off.
21.4 Remove the right part of the stitch cam in a similar way.

22. Removing the stitch cam guide plate

- 22.1 Remove the snap ring 7 and washer from the stitch cam plate shaft, and the cam plate will come off. (See Fig. 3.)

23. Removing the selection cam

- 23.1 Loosen the guide cam G clamp screws and remove the guide cam G. Then the valve cam F and the needle selection change cam will be removed.
23.2 Loosen the selection cam clamp screws and remove the selection cam.

24. Removing the guide cam F

- 24.1 Remove the right and left guide cam F clamp screws, and the right and left parts of guide cam F will come off.

25. Removing the separation cam

- 25.1 Remove the right and left separation cam clamp screws and then the cam itself.
25.2 Then the buffer R,L for selected needle will be removed themselves.

26. Removing the tuck cam

- Remove the right and left tuck cam clamp screws, and the tuck cam plate, the right and left parts of the tuck cam, the tuck cam spring, the tuck cam shafts and the clamp screws will come off.

27. Removing the carriage rear foot

- (1) Original type of KH840 (Serial No. up to 1128000)
27.1 Remove the six rear foot clamp screws and the foot will come off.
27.2 Then the selection cam for R,L end needle will be removed itself.
(2) 2nd type of KH840 (Serial No. 1128001 to 1156864)
27.1 The same way as original type
27.2 Then the selection cam for R,L end needle, the selection guide for R,L end needle and the selection change cam for R,L end needle will be removed themselves.
(3) 3rd type of KH840 (Serial No. from 1156865)
27.1 The same way as original type
27.2 Then the selection cam for R,L end needle, the selection guide for R,L end needle with end needle selection switch cam and selection guide spring will be removed themselves.

28. Removing the connecting plate**29. Removing the needle selection change plate**

- 29.1 Loosen the nut by box driver and remove the S.M. cam lever.
29.2 Loosen the needle selection change plate clamp screw and remove the needle selection change plate.

30. Removing the stripe adjuster plate

- 30.1 Remove the stripe adjuster plate clamp screw and then the plate itself.

ASSEMBLING THE CARRIAGE

1. Mounting the stripe adjuster plate

Mount the stripe adjuster plate and clamp provisionally.

2. Mounting the needle selection change plate

Put the needle selection change plate with needle selection change lever spring and fasten the needle selection change plate clamp screws. Then fit the S.M. cam lever to the needle selection change plate from outer side of the carriage and fasten the nut.

3. Mounting the connecting plate

Fit the right and left parts of the connecting plate into the carriage plate. (Take care not to mistake the right part for the left part or vice versa.)

4. Mounting the rear foot

(1) Original type of KH840 (Serial No. up to 1128000)

4.1 Put the selection cam for R,L end needle (409510001, 409513001) on the carriage plate. (place the convex part inside)

4.2 Put the rear foot into position and clamp with six screws.

(2) 2nd type of KH840 (Serial No. 1128001 to 1156864)

4.1 Put the selection cam for R,L end needle. (410781001, 410782001) (Place the convex part inside)

4.2 Fit the selection guide for R,L end needle (410779000, 410780000) to the selection cam for R,L end needle. (Take care not to mistake right and left.)

4.3 Put the rear foot with selection change cam for R,L end needle into position and clamp with six screws.

(3) 3rd type of KH840 (Serial No. from 1156865)

4.1 Put the selection cam for R,L end needle (410922001, 410923001) on the carriage plate. (Place the convex part inside.)

4.2 Fit the selection guide for R,L end needle (410924001, 410925001) with end needle selection switch cam to rear foot.

And put selection guide spring into the concave part of rear foot.

4.3 Put the rear foot into position and clamp with screws.

5. Mounting the tuck cam

Fit right and left clamp screws into the tuck cam plate, mount the right and left parts of the tuck cam, the tuck cam collar and the tuck cam spring on the screws, and clamp. (Be careful of the direction of the tuck cam spring.)

Note: Keep the tuck cam open sideways. It should return easily under spring pressure.

6. Mounting the separation cam

6.1 Put the buffer R,L for selected needle into the carriage plate.

6.2 Put the left part of the separation cam on the left end of the carriage. Then clamp the separation cam clamp screw into the outer screw hole.

6.3 Fit the right part of the separation cam in a similar way.

7. Mounting guide cam F

7.1 Mount the left part of guide cam F and clamp.

7.2 Mount the right part of guide cam F in a similar way.

8. Mounting the selection cam

8.1 Fit the selection cam and clamp with screw.

8.2 Put the needle selection change cam into the hole of shaft on the carriage plate. And put the pin of needle selection change cam into the hole of needle selection change plate.

8.3 Put the valve cam F into the shaft of the carriage plate.

8.4 Fit the Guide cam G to selection cam and clamp with screw.

9. Mounting the stitch cam guide plate

9.1 Mount the stitch cam guide plate from the outer side of the carriage. Put washers on the right and left parts of the stitch cam shaft bearing from the back side of the carriage and stop with snap ring 7.

10. Mounting the stitch cam

10.1 Fit the left part of the MC cam, the sub stitch cam shaft (collar), the left part of the valve cam D spring, the left part of valve cam D, the stitch cam and the left part of the sub stitch cam into the carriage plate in this order and clamp with a screw. Fix with a nut from the outer side of the carriage. (The ring part of the valve cam D spring should be hung from valve cam D and the hook part from the left part of the sub stitch cam.)

10.2 Mount the right part of the stitch cam in a similar way.

10.3 Clamp the stitch cam shaft with a washer and snap ring 3 on the outer side of the carriage.

Note: 1. The MC cam, valve cam D and the stitch cam should work easily.

2. Valve cam D should return under spring pressure.

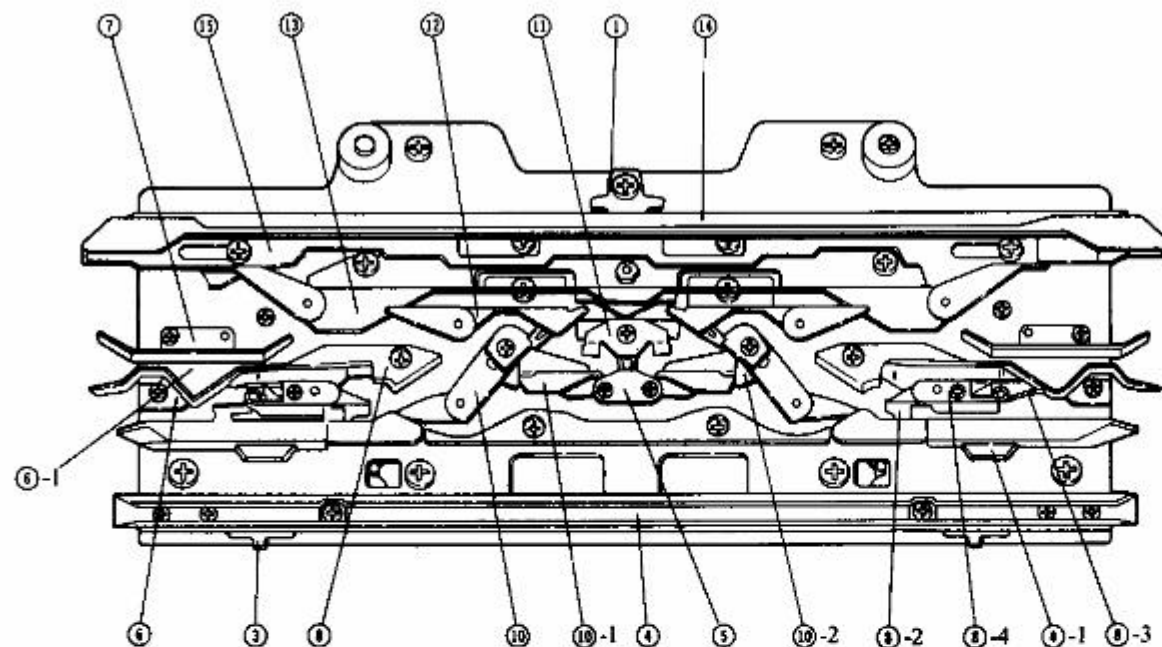

Fig. 4

Name of parts

- ① Stripe adjuster plate
- ② Connecting plate
- ③ Rear foot
- ④ Selection cam for end needle (original type)
- ④-1 Selection guide for end needle (2nd, 3rd type)
- ⑤ Tuck cam
- ⑥ Separation cam
- ⑥-1 Buffer for selected needle
- ⑦ Guide cam F
- ⑧ Selection cam
- ⑧-2 Needle selection change cam
- ⑧-3 Valve cam F
- ⑧-4 Guide cam G
- ⑩ Stitch cam
- ⑩-1 MC cam
- ⑩-2 Valve cam D
- ⑪ Guide cam C
- ⑫ Guide cam B
- ⑬ Guide cam A
- ⑭ Front foot
- ⑮ Front slide plate

11. Mounting guide cam C

Build the slide cam guide, shaft for guide cam C, Valve cam C spring and valve cam C in this order. And clamp with screw. (The ring part of the valve cam C should be hung from valve cam C and the hook part from the right-hand notch of guide cam C.)

Note: The valve cam C should work easily. Valve cam C should return to the center under spring pressure.

12. Mounting guide cam B

Fit the valve cam B spring onto the valve cam B shaft and put guide cam B in position b and clamp with a screw while keeping valve cam B at the ring part of the valve cam B spring.

Note: Turn valve cam B inside the sub stitch cam.

13. Mounting guide cam A

Mount guide cam A and slide cam clamp with right and left screws.

14. Mounting the carriage front foot

Tighten the two screws provided near the center of the carriage front foot.

15. Mounting the front slide plate

15.1 Put the front slide plate on the carriage front foot and clamp with set-screws. (The longer screw is used for left side.)

Note: See to it that the slide plate will work easily and that the holding cam will go down when the slide plate is moved to the H (Holding) position.

15.2 Fix the holding cam lever shaft with a washer and H.C.L. spring from the outer side of the carriage.

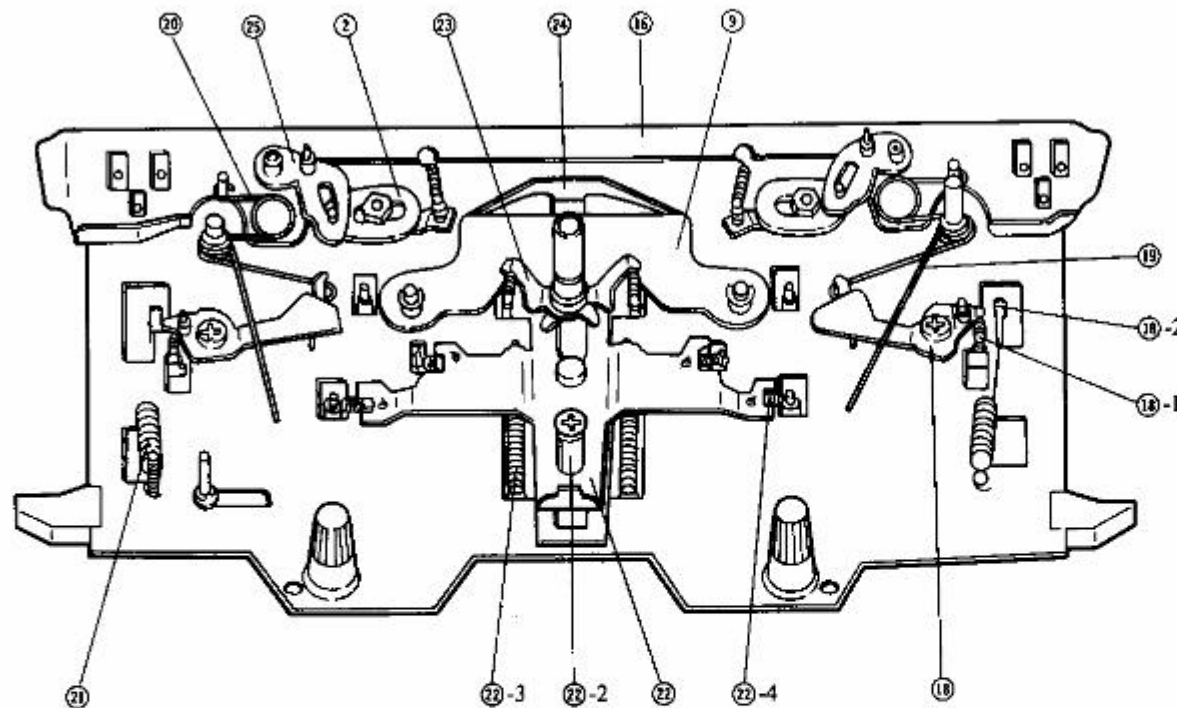

Name of parts

- ① S.M. cam lever
- ② Stitch cam guide plate
- ⑬ Rear plate
- ⑭ Cam change plate
- ⑭-1 End needle selection cam spring
- ⑭-2 Selection cam for end needle
- ⑰ Valve cam E spring
- ⑳ Connecting plate spring
- ㉑ Valve cam F spring
- ㉒ Change plate
- ㉒-2 Change plate guide collar
- ㉒-3 Change plate spring
- ㉒-4 MC cam spring
- ㉓ Tuck cam operating plate
- ㉔ Stitch cam guide plate spring
- ㉕ S.M. cam change crank

Fig. 5

16. Mounting the rear plate

- 16.1 Put the rear plate on the carriage plate.
- 16.2 Hook the needle selection change lever spring to the calking of rear plate.

17. Mounting the row counter tripper

- 17.1 Put the row counter tripper on the left side of the carriage plate.
- 17.2 From inner side of the carriage fasten two screws.

18. Mounting the cam change plate

- 18.1 Put the cam change plate with end needle selection cam spring on the carriage and fasten the screws.
- 18.2 Hook the end needle selection cam spring to the hook of selection cam for R.L. end needle in outer side of the carriage.

19. Mounting the valve cam E spring

- 19.1 Fit the valve cam E spring to the shaft of carriage.
- 19.2 Hook the U part to the valve cam E (which is combined with rear foot.).

20. Mounting the connecting plate spring

- 20.1 Hook the connecting plate spring, right to the shaft for change knob.
- 20.2 Hook the connecting plate spring, left to the shaft for valve cam E spring. (Take care not to mistake right or left.)

21. Mounting the valve cam F spring

- 21.1 Hook the valve cam F spring to the valve cam F and the pin of front slide plate clamp screws.

22. Mounting the change plate

- 22.1 Mount the change plate with the change plate guide collar.
- 22.2 Tighten the change plate guide collar with a nut from the back side of the carriage.
- 22.3 Hook the change plate spring to the hook of the change plate and front foot.
- 22.4 Hook four points of the MC cam spring to the right and left parts of the MC cam and the right and left parts of the hook of the guide cam B.

Note: The change plate, the right and left parts of the MC cam and the right and left parts of MC knitting change cam (the guide cam B) should return under spring pressure after being pressed. The change plate should operate easily.

23. Mounting the tuck cam operating plate

- 23.1 Put the right part of the tuck cam operating plate on the tension dial shaft and place on it the left part of the tuck cam operating plate and the collar.
- 23.2 Hook the right and left ends of the tuck cam operating plate spring to the tuck cam calking pin.

24. Mounting the stitch cam guide plate spring

Mount the stitch cam guide plate spring.

25. Mounting the S.M. cam change crank

- 25.1 Put the S.M. cam change crank into the Pin of rear foot clamp screw.
- 25.2 Fix the hole of S.M. cam change crank to the short pin of S.M. cam lever.

26. Mounting the upper slide plate

- 26.1 Insert the grooves of the upper slide plate into 4 pins of S.M. cam change crank, two shafts hooked connecting plate spring and cam change plate.
- 26.2 Fix the plate with snap ring at the shaft hooked connecting plate spring and valve cam E spring.

27. Mounting the change knob

- 27.1 Insert the change knob into the right shaft for change knob.

Note: 1. In condition that the upper slide plate is left end, the red mark of change knob should indicate downwards.
2. The upper slide plate should move easily.

28. Mounting the handle base

- 28.1 Clamp the right and left parts of the handle base with two clamp screws.
- 28.2 Clamp the right and left parts of the handle lock spring with screws.

29. Mounting the cam button unit

- 29.1 Mount the cam button unit on the tension dial shaft and clamp with screws at right and left.
- 29.2 Hook the raising cam change spring cam calking pin.

Note: 1. The cam should be switch accurately when the right or left of the TUCK, the right or left of the PART or MC button is pressed.
2. When the change knob is moved to N.L. position (the red mark indicates downwards), the TUCK, the PART and MC button pressed before should return.

30. Mounting the carriage cover

- 30.1 Put the H.C.L. knob into the holding cam lever shaft.
- 30.2 Put the Plain lever knob into the cam button unit.
- 30.3 Mount the carriage cover and clamp with a screw from the back of the carriage.

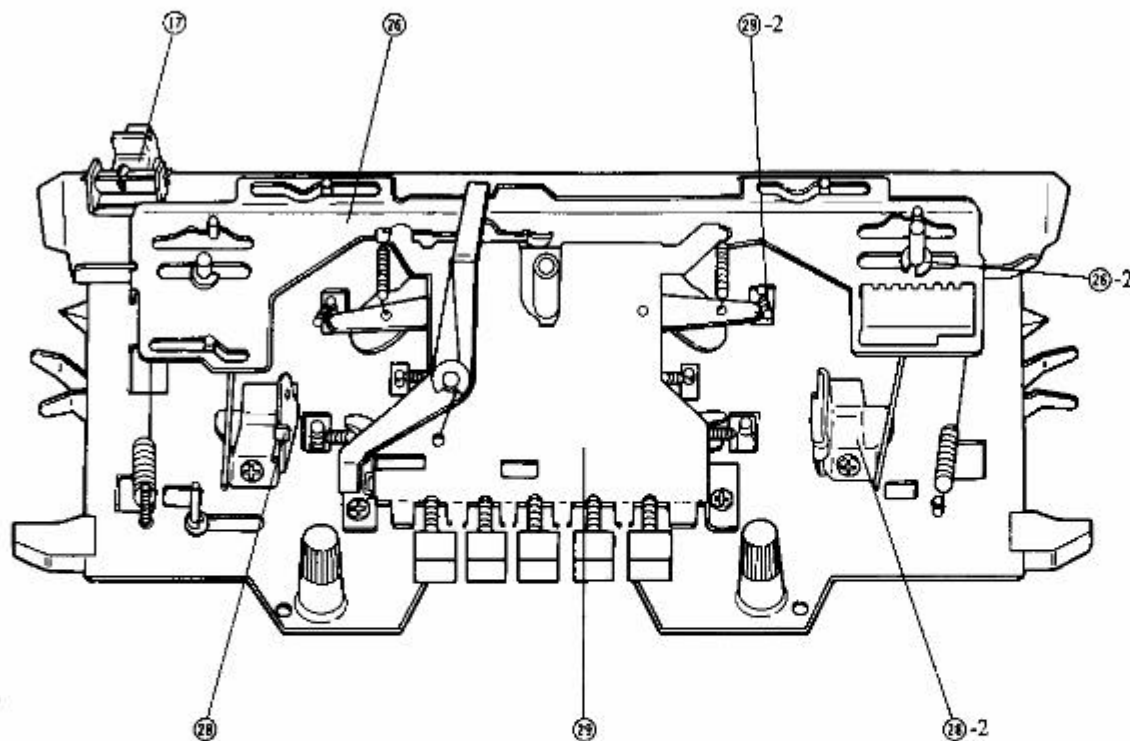

Name of parts	
①⑦	Row counter tripper
②⑥	Upper slide plate
②⑥-2	Snap ring
②⑧	Handle setting base
②⑧-2	Handle lock spring
②⑨	Cam button unit
②⑨-2	Raising cam change spring

Fig. 6

31. Mounting the stitch dial

- 31.1 Fit the stitch dial on the shaft and clamp with a screw in such a manner that the notch in the stitch dial presser cap comes in front.
- 31.2 Bring the mark of the stitch dial presser cap to the notch in the knob retainer and put the cap in position.

32. Mounting the handle

Clamp the handle pin while keeping the handle horizontal.

SINGLE MOTIF MECHANISM

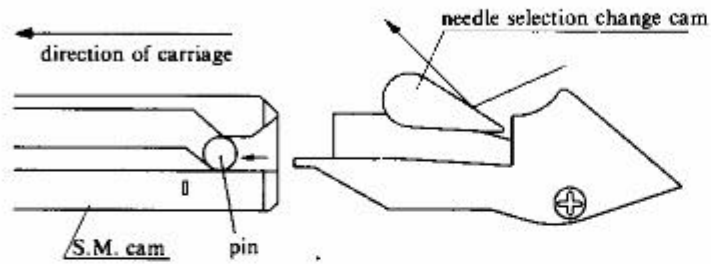

1. When the carriage doesn't go through the single motif cam (Before or after going through), the pin of S.M. cam lever remains at original position and needle selection change cam which is connected with S.M. cam lever doesn't work.
2. Accordingly the needles doesn't go through the selection cam, needle will not be selected.

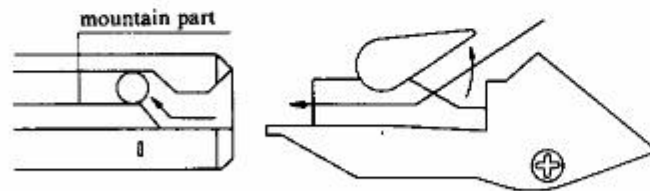

1. When the carriage goes through the S.M. cam, the pin of S.M. cam lever moves to mountain part. And the needle selection change cam moves toward the rear foot.
2. Accordingly the needles will be selected.

CAM BUTTON AUTO RESET MECHANISM

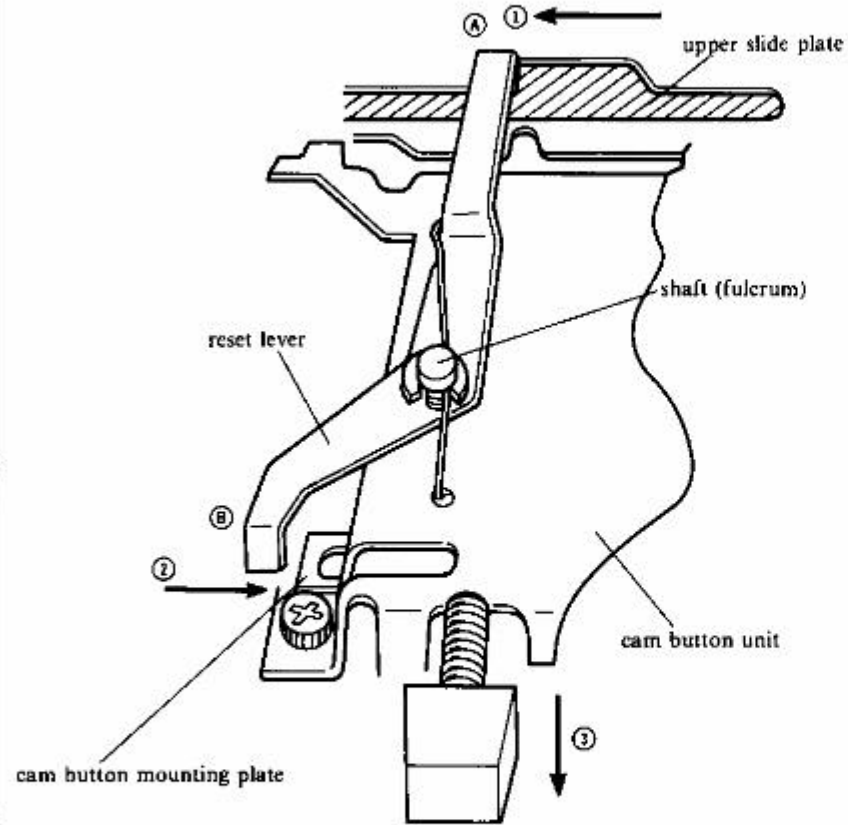

1. When the change knob is set from "SM" or "KC" to "NL", reset lever (A) is moved to left by upper slide plate.
2. The reset lever (B) moves to right and pushes the cam button mounting plate.
3. Accordingly cam button will be reset automatically.

END NEEDLE SELECTION MECHANISM

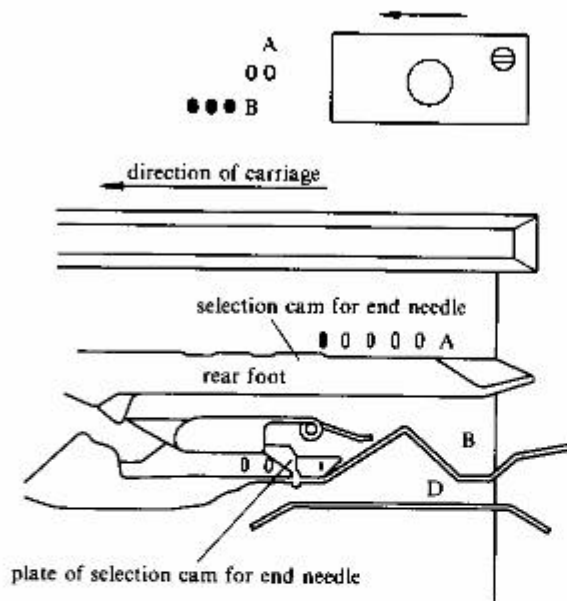

I. ENTRY SIDE

- (i) While the carriage go through A position needles, the selection cam for end needle (selection guide for end needle) is pushed forward by A position needle. Accordingly this keeps the plate of selection cam for end needle pushed forward.
- (ii) Just before the last needle at A position remove from selection cam for end needle (or selection guide for end needle), the first needle at B position which is next to last A position needle is pushed into the direction between the separation cam and guide cam F. Accordingly end needle at B position will be selected to D position.

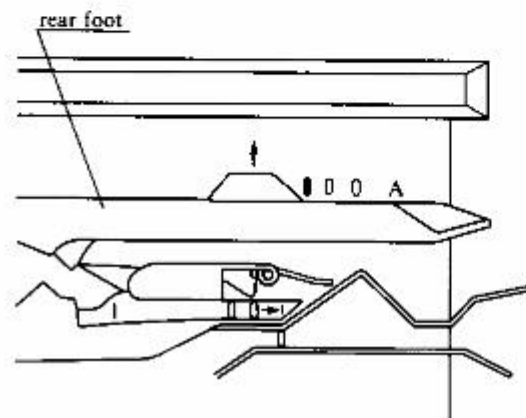

- (iii) After the last needle at A position removes from the selection cam for end needle, the plate of selection cam for end needle return to original position. Accordingly on and after 2nd needles go through normal way, the needles will be selected according to punch card.

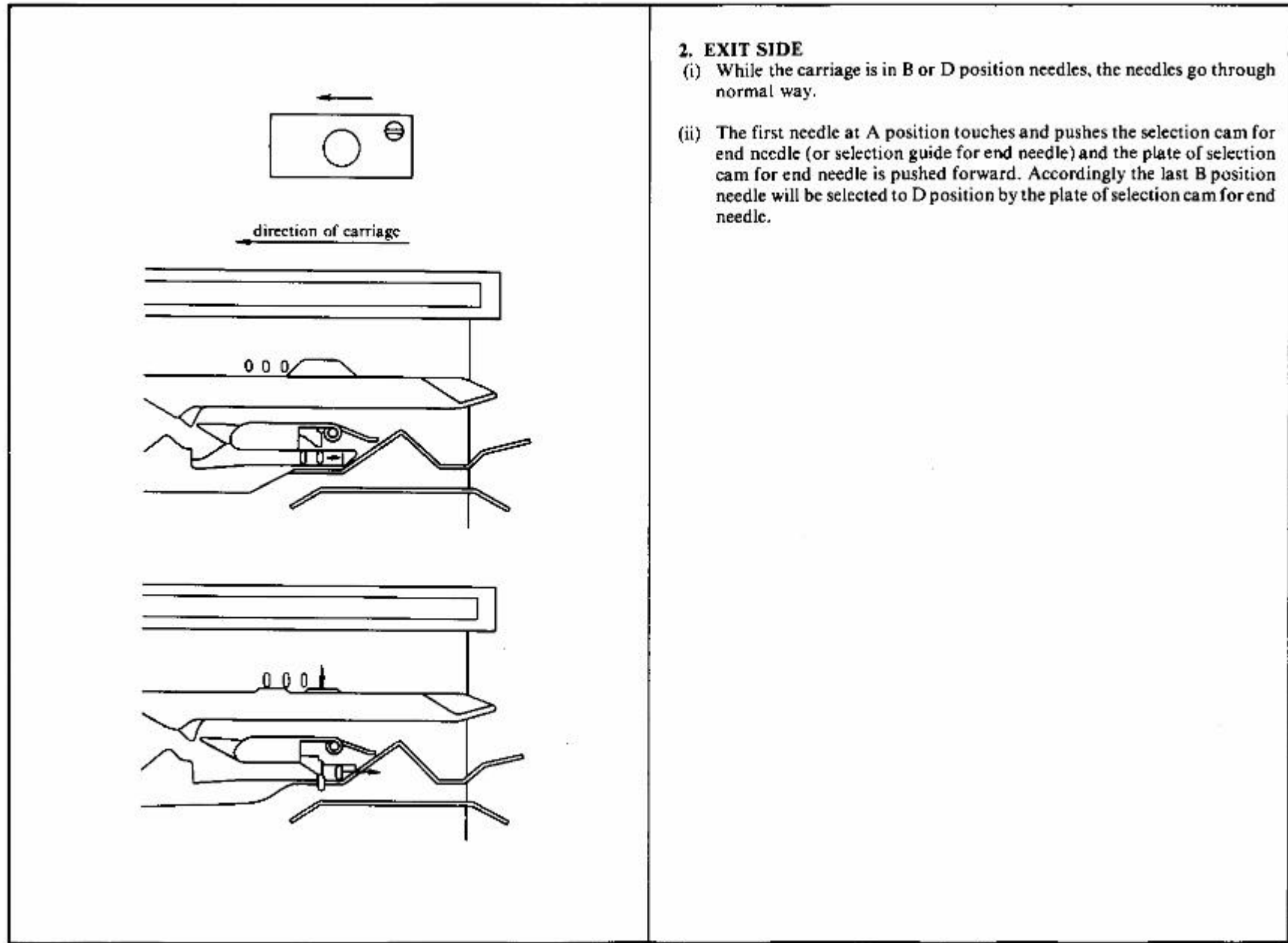

2. EXIT SIDE

- (i) While the carriage is in B or D position needles, the needles go through normal way.
- (ii) The first needle at A position touches and pushes the selection cam for end needle (or selection guide for end needle) and the plate of selection cam for end needle is pushed forward. Accordingly the last B position needle will be selected to D position by the plate of selection cam for end needle.

HOW TO ADJUST THE CARRIAGE

The carriage can't knit the single motif.
(The butt strikes against needle selection change cam.)

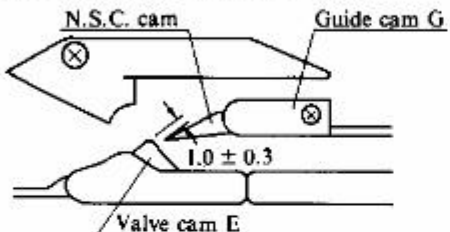
Case	Adjustment
<p>1. Needle selection change cam is defective.</p>  <p>2. Wearing down of single motif cam on carriage rear foot.</p>	<p>1. Change new N.S.C. cam (i) Remove the Guide cam G. (ii) Set the change knob "NL" and remove the N.S.C. cam.</p> <p>2. Change new single motif cam or carriage rear foot.</p> <p>NOTE: When the carriage goes through single motif cam, the top end of N.S.C. cam should be inside of valve cam E. ($1.0 \text{ m/m} \pm 0.3$)</p>

MEASUREMENT OF CARRIAGE CAM

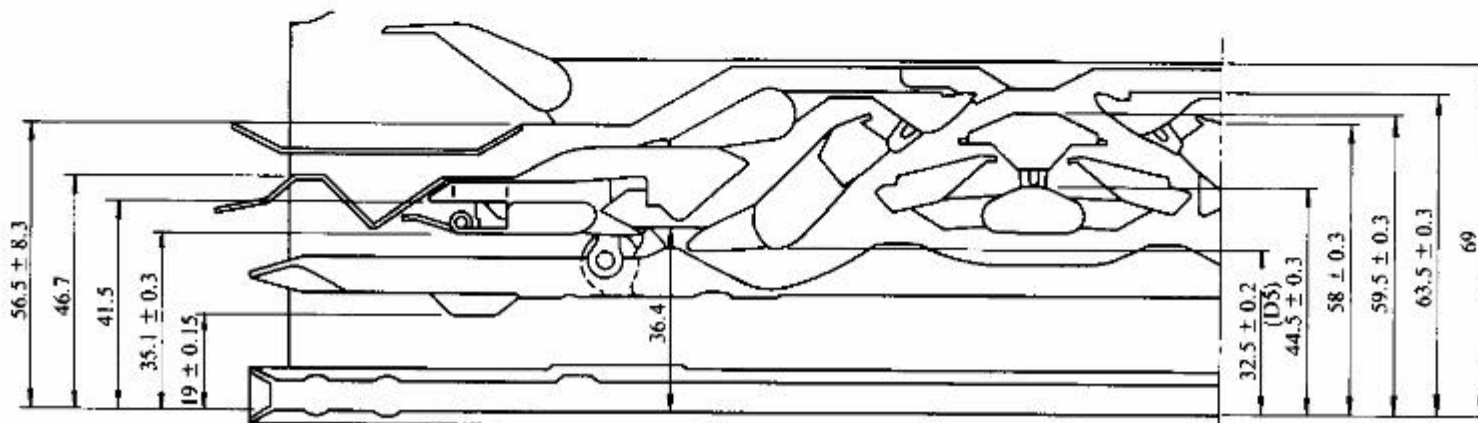

(m/m)

CHECKING THE CARRIAGE FUNCTIONS

1. Change knob function	1.1 When the change knob is switched to each position, it should move smoothly; the right or left part of the connecting plate and the needle selection change cam, valve cam E. S.M. cam lever and selection cam for end needle (selection guide for end needle).
2. MC cam operating	2.1 When the end of the right or left part of the MC cam is pressed fully down and then quietly lifted with your finger while keeping the MC button depressed all the time, the right and left parts of the MC cam should return to their original position under spring pressure.
3. MC knitting change cam (guide cam B) operation	3.1 The right and left parts of the MC knitting change cam should shift without fail while the MC button is kept depressed.
4. Raising cam operation (stitch cam)	4.1 When the end of the right or left part of the raising cam is lifted fully with the stitch dial at the 0, 5, or 10 position and quietly lowered with your finger, the right or left part of the raising cam should return to its original position without fail under spring pressure.
5. Needle selection change cam operation	5.1 When the needle selection change cam is set at "SM", "NL" and when the end of the right or left part of the needle selection change cam is fully lifted and then quietly lowered with your finger, the cam should return to its original position without fail under spring pressure.
6. Tuck cam operation	6.1 When the right or left part of the tuck cam button is depressed, and when the end of the right or left part of the cam is fully lifted and then quietly lowered with your finger, the right or left part of the tuck cam should return to its original position without fail under spring pressure. 6.2 When the ca button is set at plain, and when the end of the right or left part of the tuck cam should return to its original position without fail under spring pressure.
7. Cam button unit function	7.1 When the cam button is shifted to "TUCK right and left," "MC", or "PART right and left," the button should move smoothly and the tuck cam, the MC cam and the raising cam should shift their places without fail.
8. Holding cam lever function	8.1 When the holding cam lever is shifted to "H" or "N", it should move smoothly and the holding cam should make accurate operation without fail.
9. Plain knitting lever function	9.1 When the plain knitting lever is thrown rightward while pressing "TUCK right and left," "MC" or "PART right and left" buttons, the lever should move smoothly and the cam button should return to its original position without fail.
10. End needle selection cam function	10.1 When the change knob is switched to "SM" "KC" position and end needle selection cam is in working position and selection cam for end needle (selection guide for end needle) is fully lifted and quietly lowered with your finger, the cam should return to its original position without fail under spring pressure.