

INSTRUCTION MANUAL
FOR
INTARSIA CARRIAGE

MODEL
AG-20

Intarsia Carriage AG-20 knits argyle patterns without floating yarn on the back of knitted fabric.

CONTENTS

	page
Names of parts and their function	1
Needle positions	1
How to use the Intarsia Carriage	2
Hints	5
How to knit stockinet using the Intarsia Carriage	5
Practicing argyle pattern	6

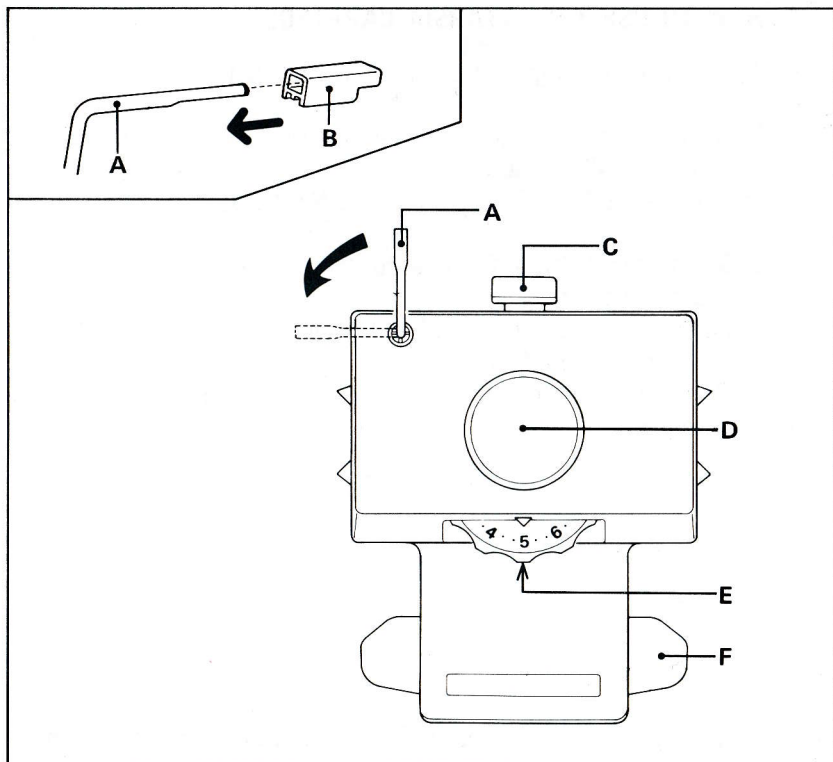

NAMES OF PARTS AND THEIR FUNCTION

- A – Row Counter Triper**
Actuates the Row Counter. When this Triper is not needed, lift it and turn it to the side.
- B – Row Counter Triper Cap**
When using the Intarsia Carriage with Model 322, 325, 326 or 327 attach the Cap to the tip of the Row Counter Triper as illustrated.
- C – Feeding Plate**
Actuates the Built-in Knit Contour.
- D – Carriage Handle**
- E – Stitch Dial**
Regulates the size of a stitch. Use the same Stitch Dial number as required for the Main Carriage.
- F – Fabric Presser**

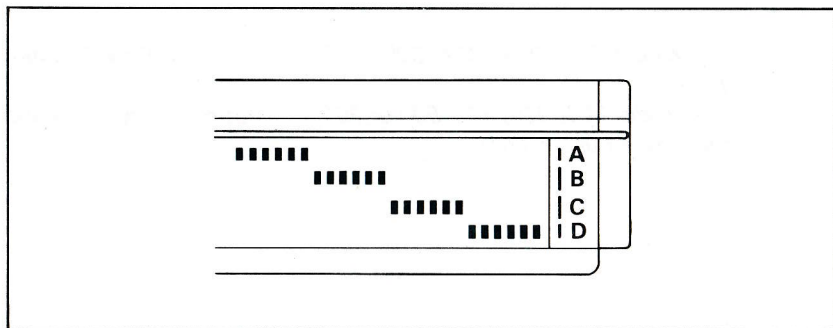

NEEDLE POSITIONS

To operate the needles, align their butts within the brackets.

- A – needles do not knit.**
- B – needles knit stockinet.**
- C – needles knit stockinet.**
needles are always aligned in this position when the Intarsia Carriage is used.
- D – needles do not knit.**
align needles in this position when moving the Intarsia Carriage without knitting or working partial knitting.

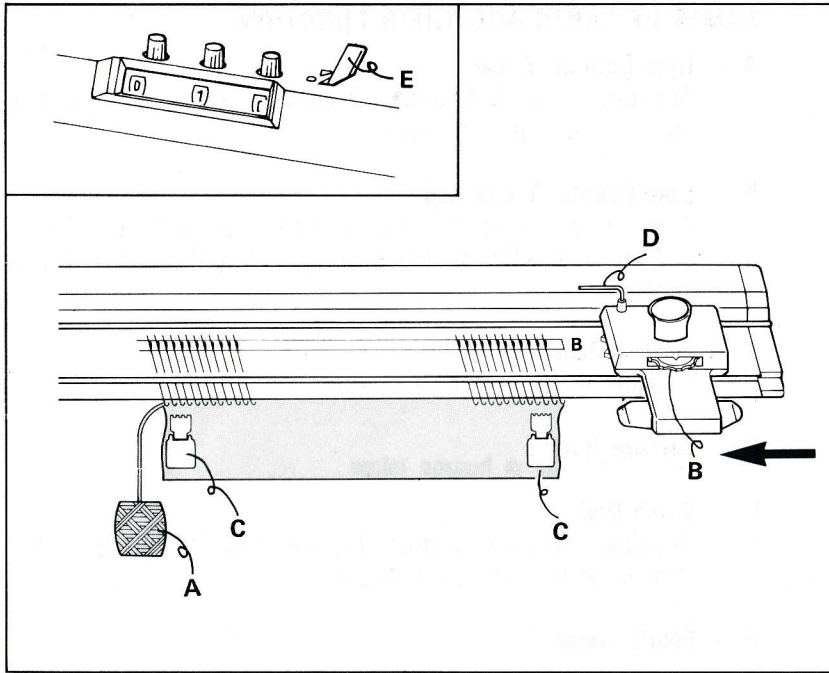

HOW TO USE THE INTARSIA CARRIAGE

1. With Main Carriage cast on and knit stockinet.
2. Remove yarn from the Yarn Feeder and Auto Tension and place yarn ball "A" on the floor. Remove the Main Carriage from the Needle Bed.
3. Mount the Intarsia Carriage to the Needle Bed from the side without the yarn. Adjust the Stitch Dial "B" and hang the Claw Weights "C" on both edges of the fabric. Disengage the Row Counter Triper "D" or Row Counter Set Lever "E".

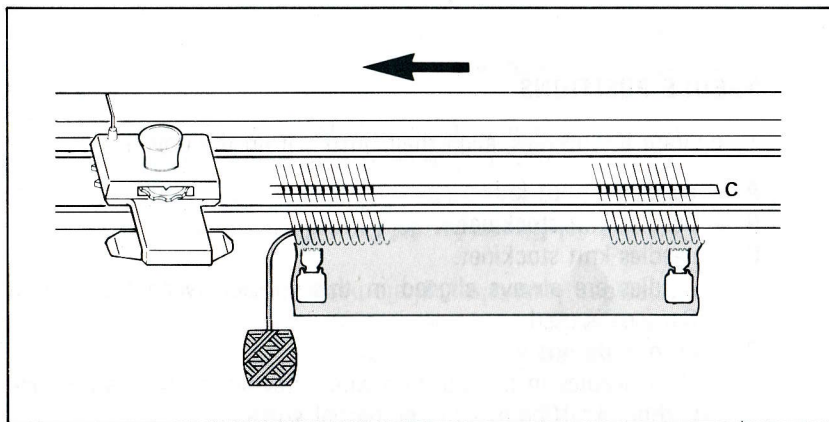

4. Move the Intarsia Carriage across the needles in B position without knitting, aligning the needles in C position.

For Model 321, 323, 327, 329 or 260, engage the Row Counter Triper.

For Model 325, 326, 328, 500 or 360, it is not necessary to engage the Row Counter Triper.

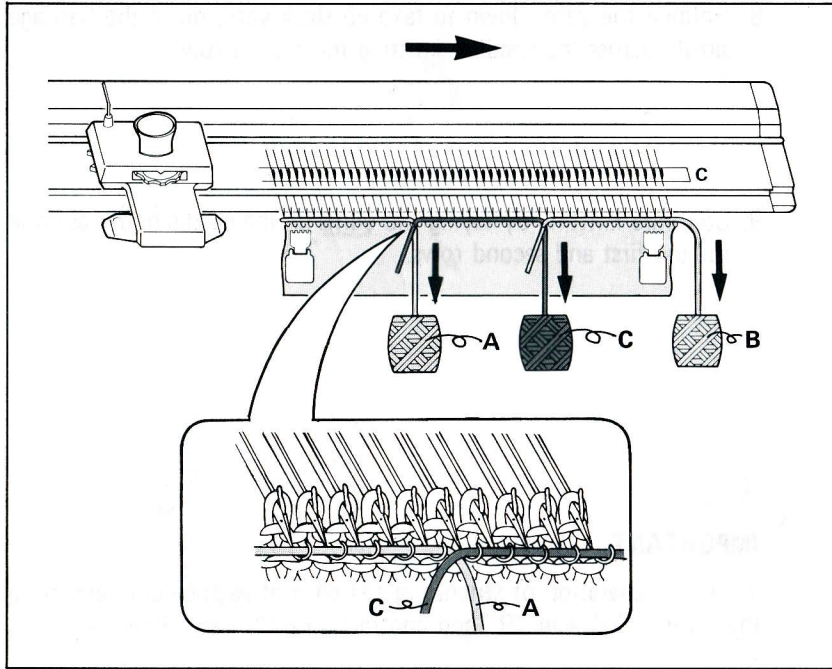

5. Lay main yarns "A" & "B" and contrast yarn "C" starting from the Carriage side as illustrated.

Be sure to open latches of the needles before laying yarns.

6. Holding the yarns down to take up slack yarn, move the Carriage slowly across the needles, knitting the first row.

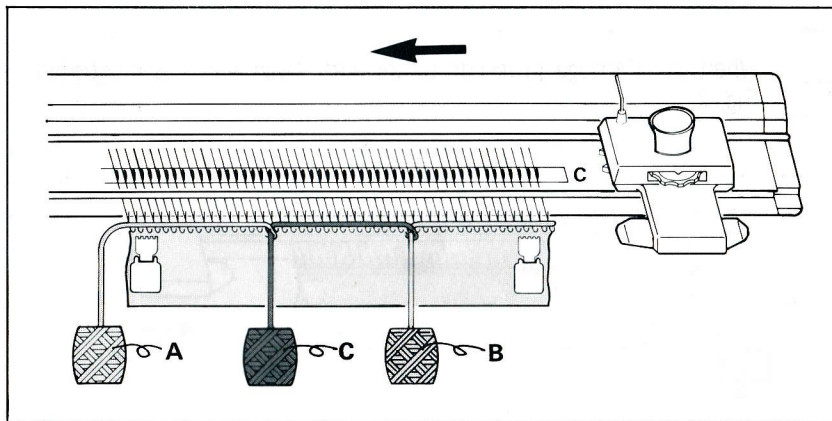

7. Lay main yarns "A" & "B" and contrast yarn "C" on the needle hooks starting from the Carriage side as illustrated.

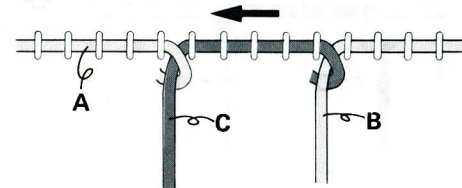

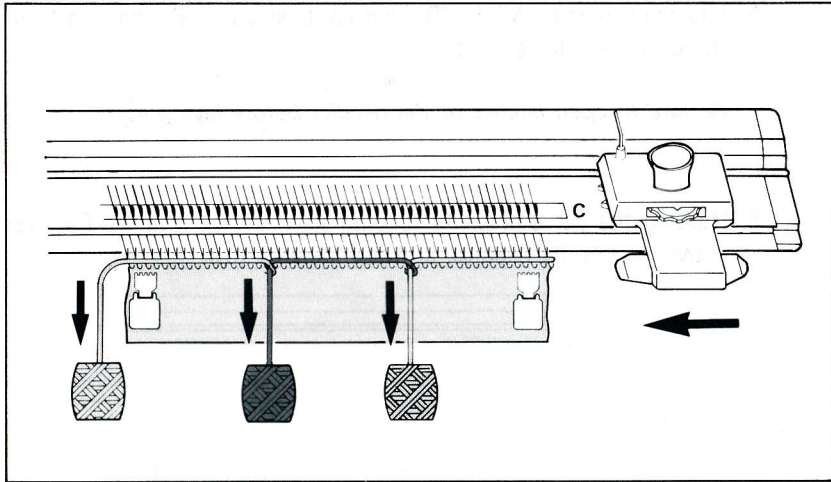

8. Holding the yarns down to take up slack yarn, move the Carriage slowly across the needles, knitting the second row.

9. Continue knitting by laying the yarns on the needle hooks as done for the first and second rows.

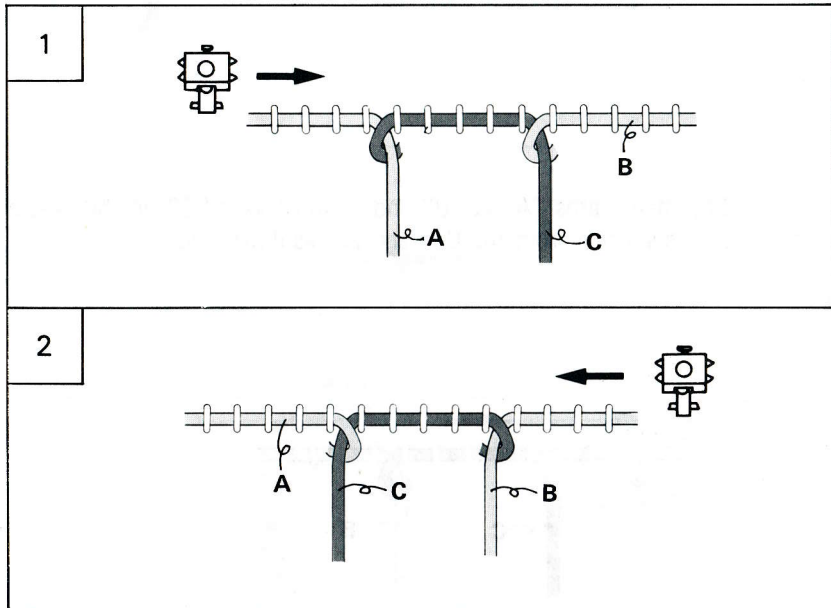

IMPORTANT

To avoid separation of stitches at the edge of each colour yarn, twist main yarns "A" and "B" and contrast yarn "C" as follows:—

When the Carriage proceeds to the right, twist yarns as illustrated in Fig. 1.

When the Carriage proceeds to the left, twist yarns as illustrated in Fig. 2.

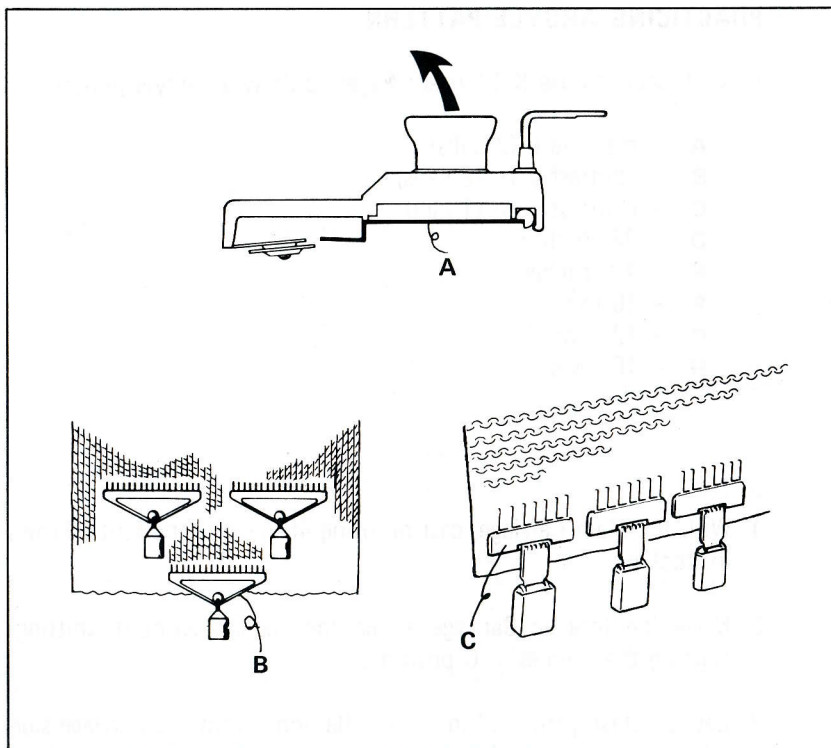

HINTS

★ If the Intarsia Carriage has jammed while knitting, lift it from the Needle Bed "A" by holding the Carriage Handle.

★ When using thick yarns, pull the fabric down before moving the Intarsia Carriage so that stitches are formed correctly on the needles.

Use of Weight Hangers "B" or Comb Weights "C" with Weights eliminates pulling down the fabric.

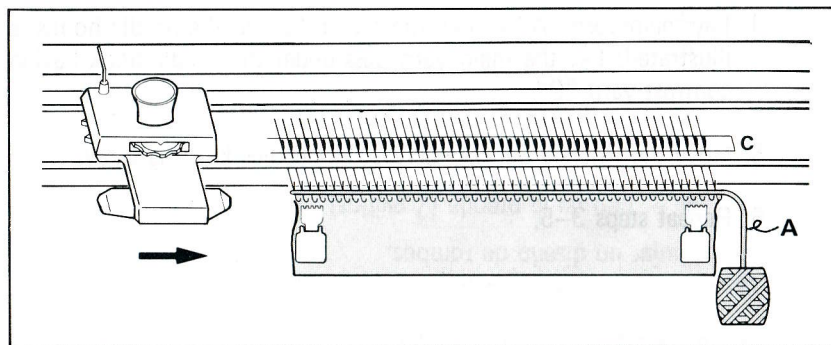

HOW TO KNIT STOCKINET USING THE INTARSIA CARRIAGE

1. Lay main yarn "A" on hooks of the needles in C position before moving the Argyle Carriage.
2. Move the Intarsia Carriage, knitting a row.

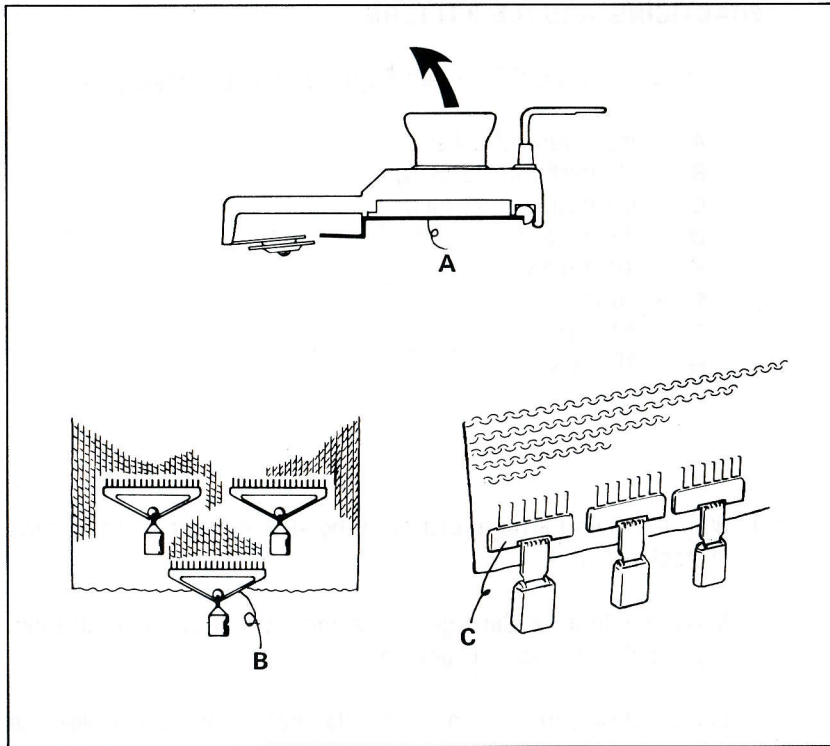

HINTS

★ If the Intarsia Carriage has jammed while knitting, lift it from the Needle Bed "A" by holding the Carriage Handle.

★ When using thick yarns, pull the fabric down before moving the Intarsia Carriage so that stitches are formed correctly on the needles.

Use of Weight Hangers "B" or Comb Weights "C" with Weights eliminates pulling down the fabric.

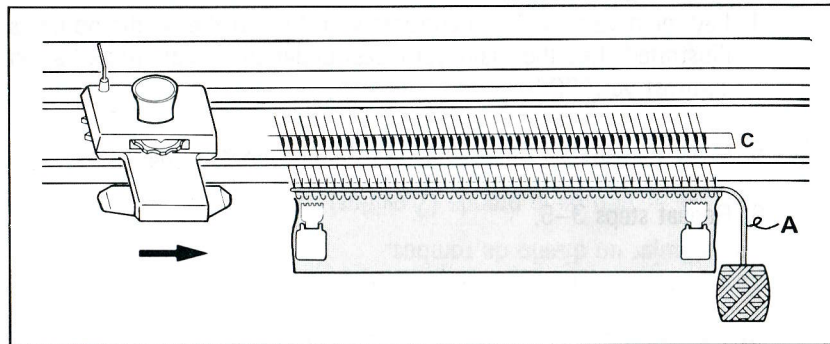

HOW TO KNIT STOCKINET USING THE INTARSIA CARRIAGE

1. Lay main yarn "A" on hooks of the needles in C position before moving the Argyle Carriage.
2. Move the Intarsia Carriage, knitting a row.

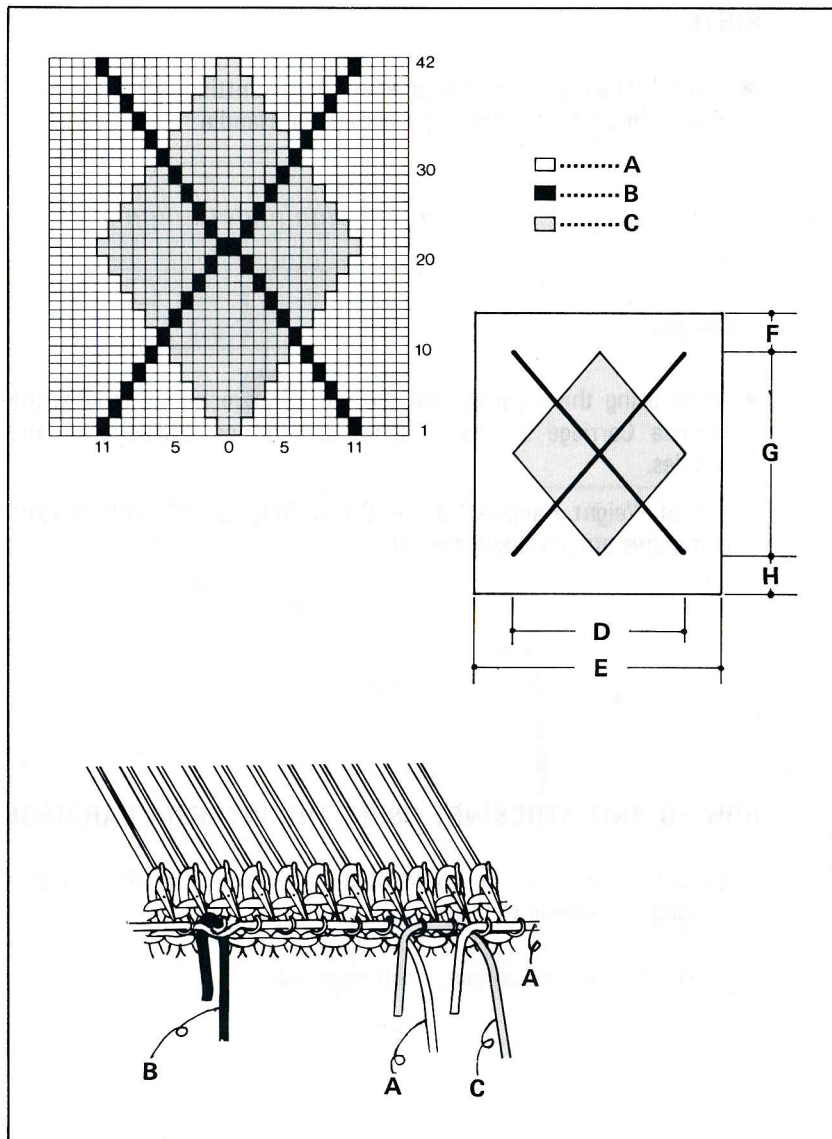

PRACTICING ARGYLE PATTERN

It is advisable to use KR Pattern Paper to draw an argyle pattern.

- A** – main yarn (2 balls)
- B** – contrast yarn (2 balls)
- C** – contrast yarn (1 ball)
- D** – 22 stitches
- E** – 40 stitches
- F** – 10 rows
- G** – 42 rows
- H** – 10 rows

1. With the Main Carriage, cast on using 40 needles and knit 10 rows in stockinet.
2. Move the Intarsia Carriage across the needles without knitting, aligning the needles in C position.
3. Lay contrast yarn "B" in the needle hook from the Carriage side referring to pattern diagram.
4. Lay main yarn "A" and contrast yarn "C" in the needle hooks as illustrated. Let the main yarn pass under the needle hook having contrast yarn "B".
5. Move the Intarsia Carriage across the needles knitting a row.
6. Repeat steps 3–5.