

INTARSIA CARRIAGE
INSTRUCTION BOOK
NO. 188

CONTENTS

SETTING UP THE CARRIAGE	1
Names of each parts	2
Cam Lever	2
Stitch Dial	2
Yarn and Stitch Dial	3
Russel Levers	3
Feeding Levers	3
CAST-ON AND KNITTING	4
Cast-on	4
Intarsia Pattern	5
Plating	8
If the Carriage has jammed	9
MAINTENANCE	9

SETTING UP THE CARRIAGE

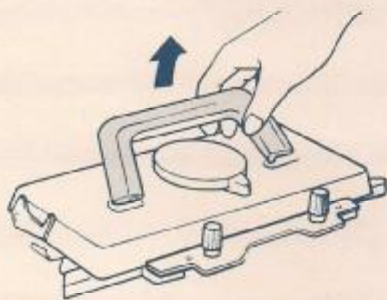

Remove the Carriage from the packing and raise the Carriage Handle.

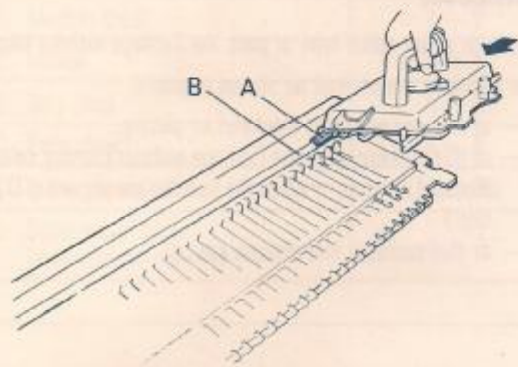

Mount the Carriage to the Needle Bed sliding the Carriage pipe "A" onto the rail "B".

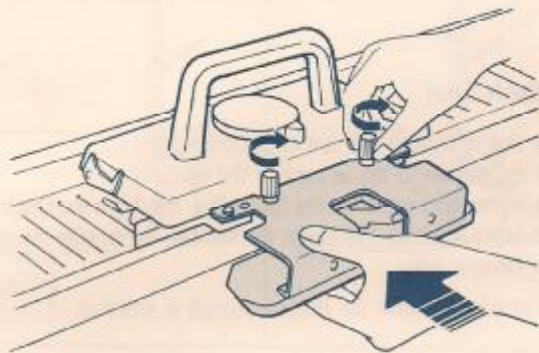

Remove the Arm from the packing and position it under the two Arm Nut screws.

Hold the Arm securely against the Carriage, and tighten the Arm Nuts by turning them in the arrowed direction.

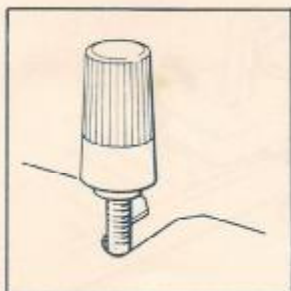

Ensure that the Arm Nuts fit properly into the cut-out of the Arm.

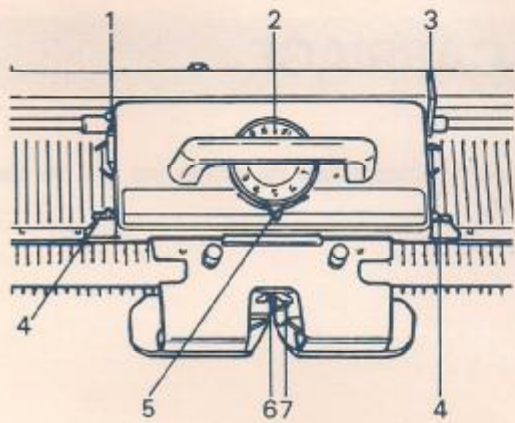

Names of each parts

- | | |
|------------------|------------------------|
| 1. KC Lever | 5. Cam Lever |
| 2. Stitch Dial | 6. Main Yarn Feeder |
| 3. RC Lever | 7. Plating Yarn Feeder |
| 4. Russel Levers | |

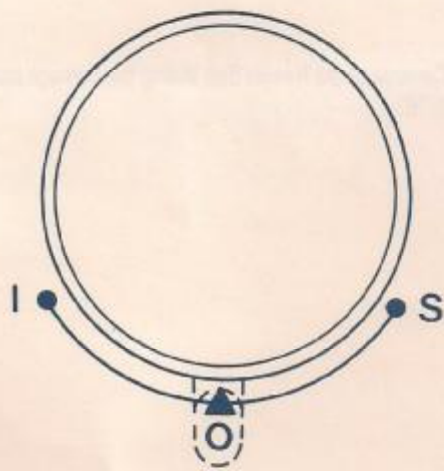

Cam Lever

Use this to select stitch type or pass the Carriage without knitting. Three positions are marked as shown opposite.

- O — at this position, knit stockinet or plating.
- S — at this position, pass the Carriage without knitting. (also set Russel Levers to — when the needles are aligned in D position.)
- I — at this position, knit intarsia pattern.



Stitch Dial

Use this to regulate the size of stitches.

Set the number to the ▲ mark at the front.

The higher the number on the Stitch Dial, the larger the stitch size (the fabric is loose). The Lower the number, the smaller the stitch (the fabric is tight).

Ⓡ is selected when the Ribber(optional) is attached.

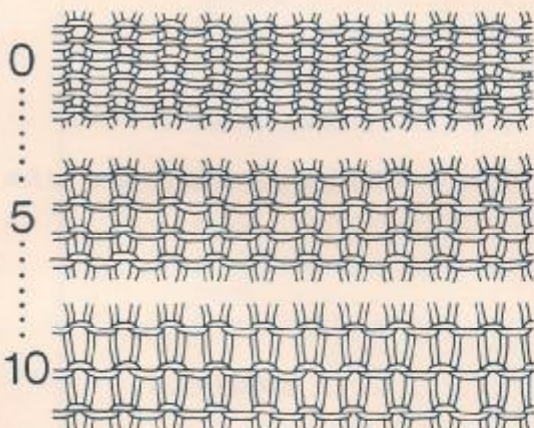

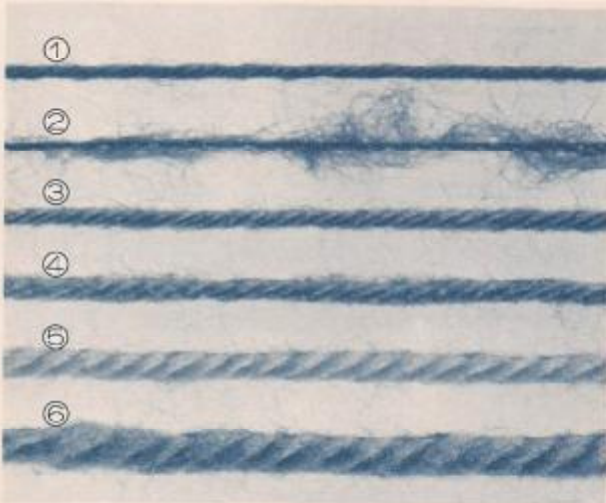

TYPE OF YARN	STITCH DIAL
① Medium thick	1 ~ 2
② Mohair	3 ~ 4
③ Very thick	5 ~ 6
④ Extra thick	6 ~ 8
⑤ Super extra thick	8 ~ 10
⑥ Super extra thick (every second needle)	6 ~ 7

Yarn and Stitch Dial

To obtain suitable stitch size, or suitable tension for a garment, set the Stitch Dial Number according to the thickness of the yarn, referring to the yarns and table opposite.

The thicker the yarn, the higher the Stitch Dial Number, and the thinner the yarn, the lower the Stitch Dial Number.

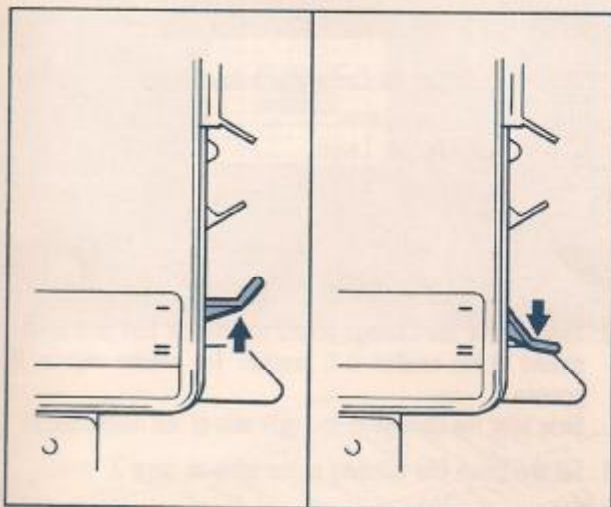

Russel Levers

These control needles in D position.

- Do not knit the needles in D position.
- = Knit the needles in D position in Stockinet.

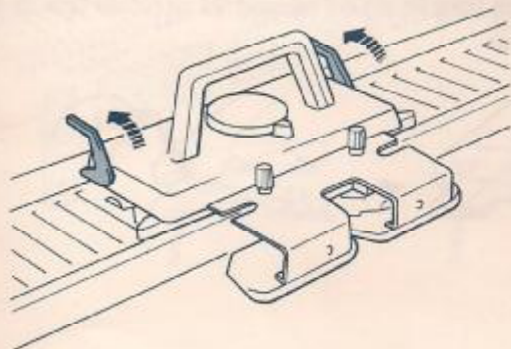

Feeding Levers

The feeding lever at the right side of the Carriage is designated as RC Lever and operates both the Row Counter and the Knit Contour Attachment (optional) if it is in use.

The feeding lever at the left side of the Carriage is designated as KR Lever and operates the Knit Contour Attachment only.

To engage either Feeding Lever with the Row Counter, or Knit Contour, raise the lever.

CAST-ON AND KNITTING

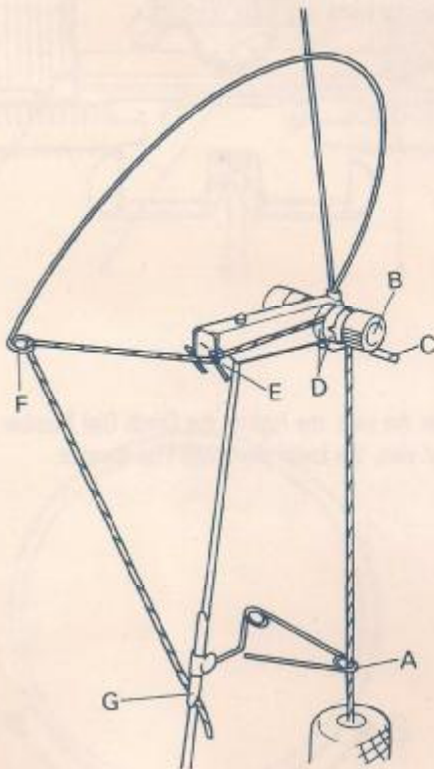

Thread the yarn through the Auto Tension following the instruction book for main Carriage.

Cast-on

1. Push the required number of needles from A position to D position.

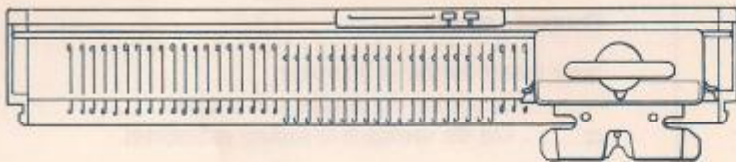

2. Set the Carriage as follows:—
 Cam Lever..... 0
 Russel Levers..... = (both)

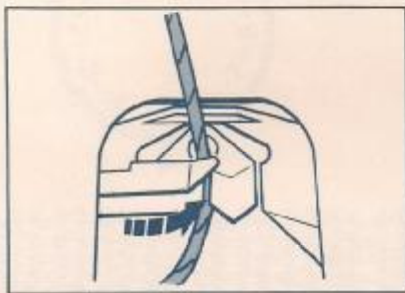

3. Slowly move the Carriage across the Needle Bed until it has passed all the needles in D position. The needles align in B position. Slide back the Carriage to the right side of the needle bed.
 4. Set the Stitch Dial referring to the table on page 3.
 5. Remove the yarn from the Yarn Clip and slip it into the Yarn Feeder.

Cast-on using Ravel Cord following the instruction book for main Carriage.

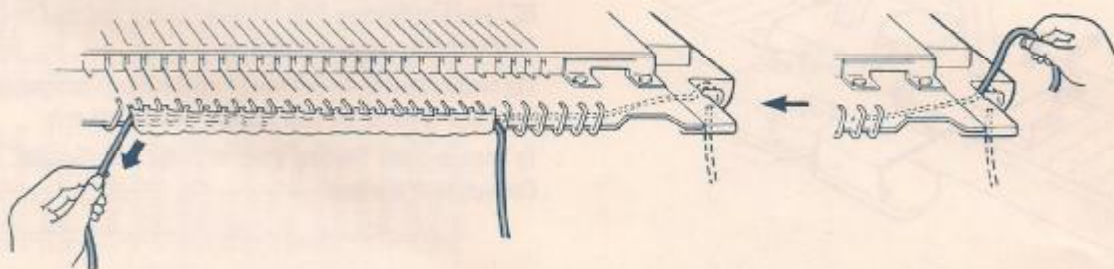





Intarsia Pattern

A practical method for knitting geometric or pictorial patterns without floats on the back of the fabric.



-  yarn A (background yarn)
-  yarn B (contrast yarn)
-  yarn C (contrast yarn)

For practice, knit following the Pattern Chart.

It is necessary to prepare each colour of yarn wound into each separate ball before starting to knit.

Prepare 3 balls of yarn A, 2 balls of yarn B and C.

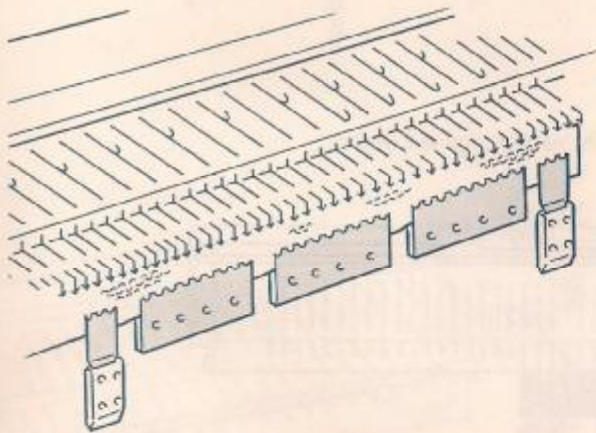

- Cast-on 37 stitches with waste yarn and knit 10 rows ending at left.
- Hang Comb Weight and Claw Weights and remove the Tuck Brushes from the Arm.
- Knit 5 rows with yarn A.
- Remove the yarn from the Yarn Feeder and Auto Tension, and place the yarn balls on the floor.

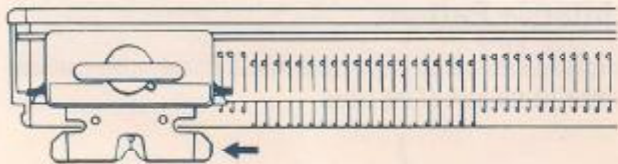

— Set the Cam Lever to "S" and move the Carriage to the left.



— Set the Cam Lever to "I" and move the Carriage to the right.
(The needles will be aligned in C position.)

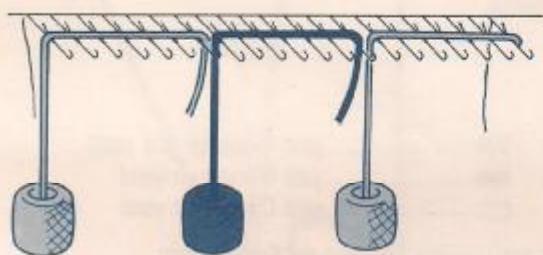

— Following the Pattern Chart, lay yarns A and B on the opened hooks starting from the Carriage side.
Be sure to open latches of the needles before laying yarn.

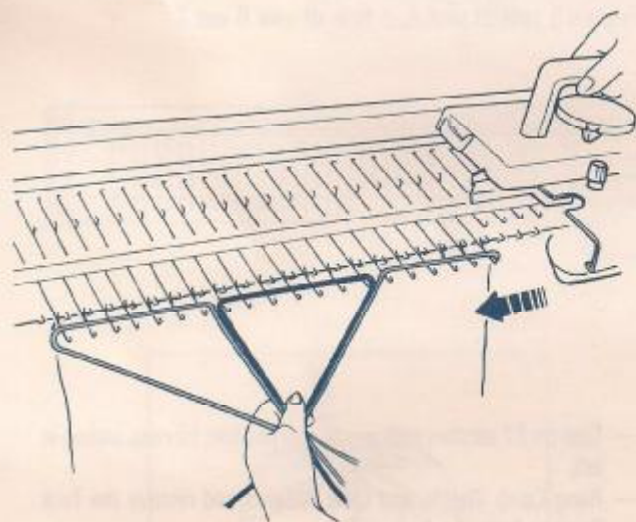

— Holding down the yarns gently only to take up slack from the yarns, and move the Carriage slowly across the needles to knit the first row.

The needles align in C position.

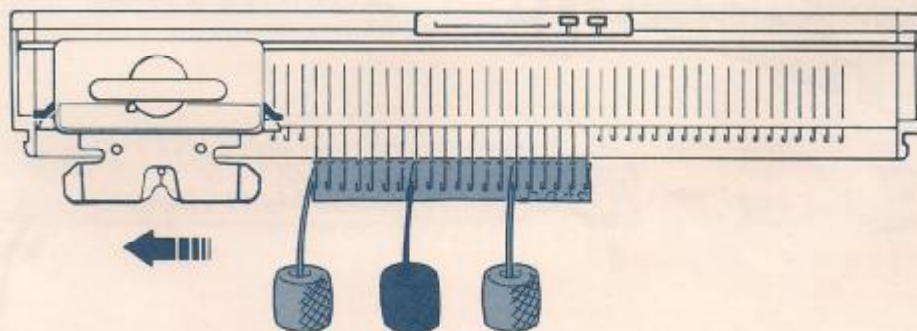



- Lay yarns on the needle hooks starting from the Carriage side. To avoid separation of stitches at the edge of each colour yarn, cross yarns as illustrated.

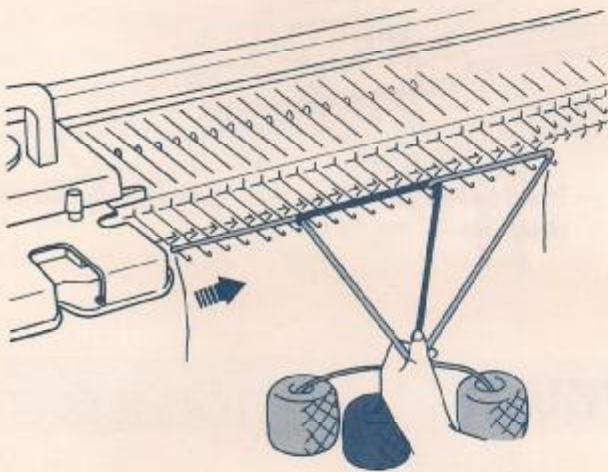
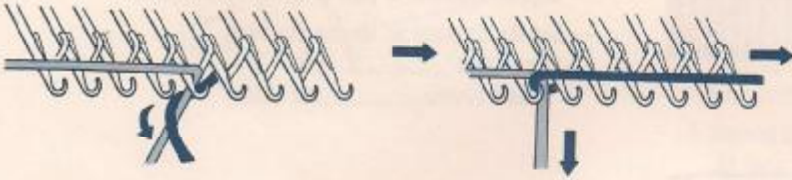

- Holding the yarns gently to take up slak, move the Carriage slowly across the needles to knit the second row.
- Following the Pattern Chart, continue knitting by laying the yarns on the needle hooks as done for the first and second rows.

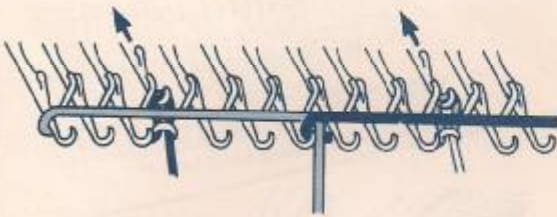
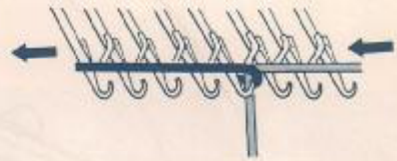

- To knit only 1 or 2 stitches in one colour, lay the yarn on those needles and push them by hand back to B position.
- Continue to knit by laying the yarns on the needle hooks omitting the needles knitted by hand.

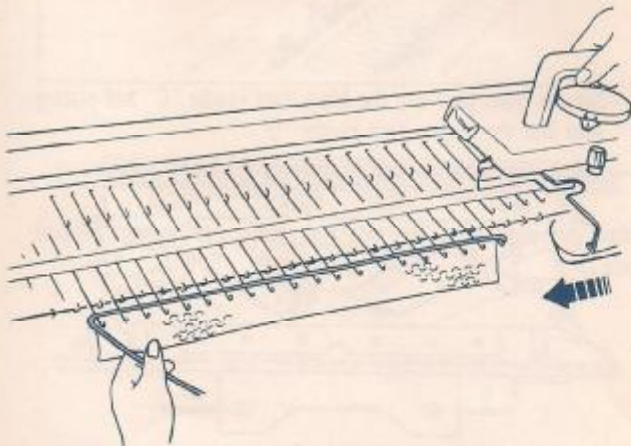

How to knit Stockinet.

- Lay the main yarn "A" on hooks of the needles in C position before moving the Carriage.
- Move the Carriage, knitting a row.



Plating

Two different colour yarns are knitted together. One yarn appears on one side while the second yarn appears on the other side of the fabric.

Since two yarns are knitted together, use thinner yarns than those for the other patterns, and Stitch Dial must be set at the number which totals the stitch dial number for each type of yarn used.

- Cast-on with waste yarn or either of two yarns.
- Set the Carriage as for the Stockinet.
 - Cam Lever..... 0
 - Russel Levers..... = (both)

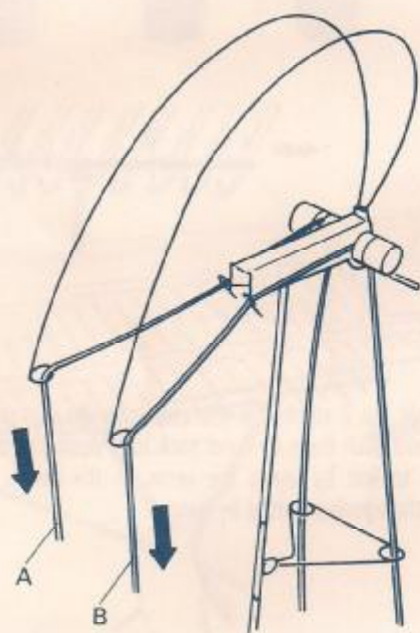
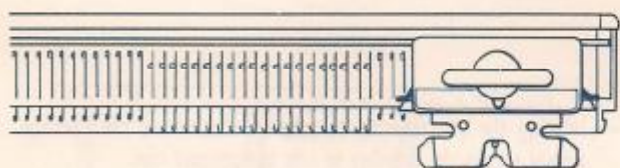

- Thread the main yarn "A" into the left side Auto Tension and the plating yarn "B" into the right one.

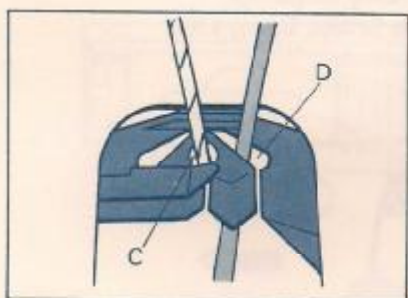

- Set the main yarn into the Main Yarn Feeder "C" and plating yarn into the Plating Yarn Feeder "D".
- Knit in the same manner as done for stockinet.

Main yarn appears on knit side and plating yarn appears on purf side.

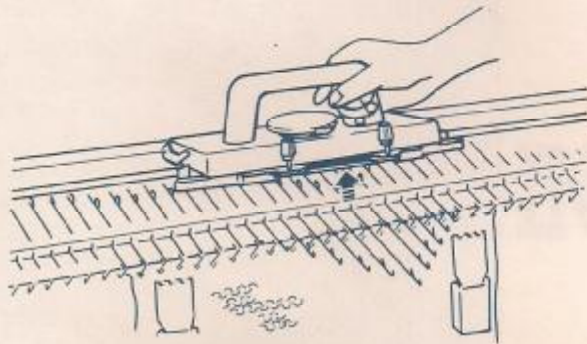
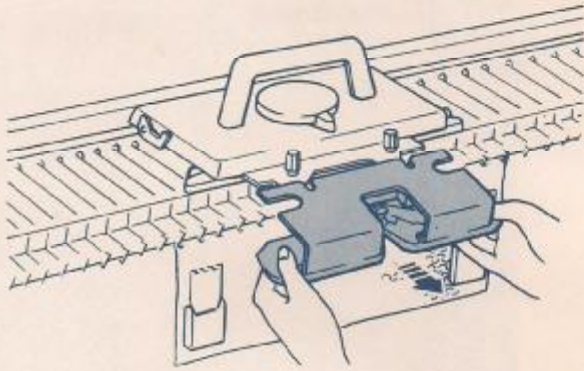

If the Carriage has jammed

In the middle of the row, do not push the Carriage by force, proceed as follows to release the Carriage from jamming.

1. Lay down the RC Lever.
2. Remove the yarn from the Yarn Feeder.
3. Loosen both Arm Nuts and remove the Arm from the Carriage.
4. Move the Carriage in its proceeding direction while lifting the front of the Carriage until it clears off the working needles.
5. Pick up dropped stitch, if any.
6. Push back the needles in C or D position to B position replacing the stitches into its needle hooks using Transfer Tool.
7. Unravel the incomplete row, and pass the Carriage to the side of the yarn end.
8. Attach the Arm.
9. Readjust the Row Counter and raise the RC Lever.
10. Replace the yarn into the Yarn Feeder.

Continue to knit.

MAINTENANCE

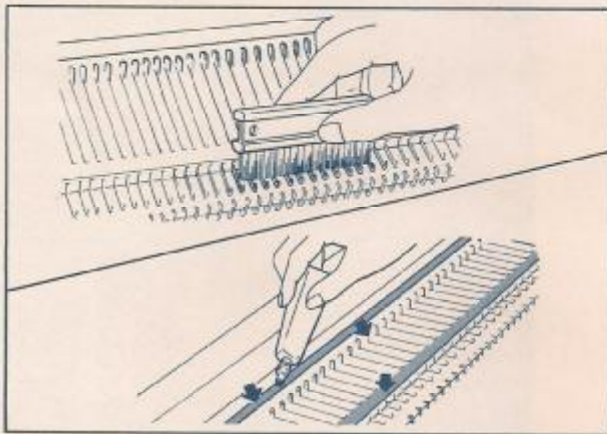

Remove the Carriage from the Needle Bed.

NEEDLE BED

Remove all lints using the Cleaning Brush.

Apply oil along the rail and front guide of the Needle Bed.

Wipe needle butts with an oil soft cloth.

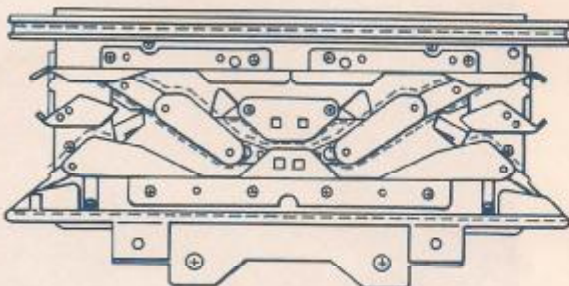

CARRIAGE

Remove the Arm from the Carriage.

Turn over the Carriage and brush off all fluff and oil the side of all the metal parts and slider and Carriage pipe.

Wipe the places indicated by the dotted line in the diagram with a piece of oil cloth.

Repack the Carriage and Arm.

