



INSTRUCTION BOOK

RIBBER CARRIAGE
RJ 1

CONTENTS

	page
RIBBER CARRIAGE	1
OPERATION TABLE	
Punch Card Knitter	3
Electronic Knitter	4
DOUBLE JACQUARD	
Punch Card Knitter	6
Punching a Card for Double Jacquard	7
Electronic Knitter	10
To change pattern while knitting Double Jacquard	12
To knit Single Motif in Double Jacquard	12
To knit Double Jacquard using Switch 3	12
To knit Double Rib which looks the same as Double Jacquard	12
If incorrectly knitted in the course of Double Jacquard	12
If incorrectly knitted in the course of Double Jacquard using Switch 3	12
MULTI COLOURED JACQUARD	13
HINTS WHEN KNITTING DOUBLE JACQUARD AND MULTI COLOURED JACQUARD	15

RIBBER CARRIAGE

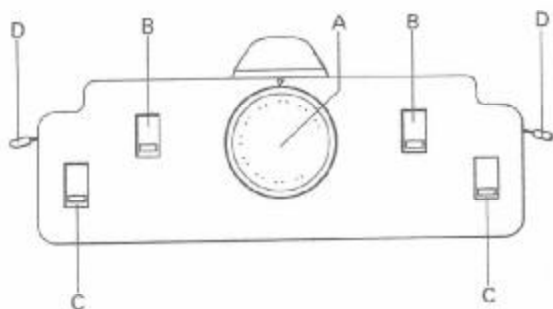

- A — Stitch Dial
- B — Set Levers
- C — Select Levers
- D — Russel Levers

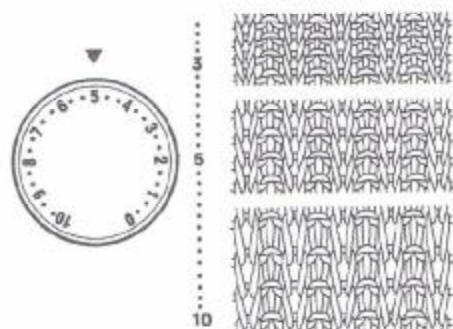

Stitch Dial

Controls stitch size.

Set a selected number or dot to ▽ mark.

The larger the number the bigger the stitch, and the smaller the number the smaller the stitch.

According to the thickness of yarn to be used, select proper setting of Stitch Dial.



Set Levers

Control needles in "B" position.

- Ⓐ NON KNITTING POSITION, needles in B position will not knit.
- Ⓑ KNITTING POSITION, needles in B position will knit.

Left Lever works when the Carriage moves to the left.
Right Lever works when the Carriage moves to the right.

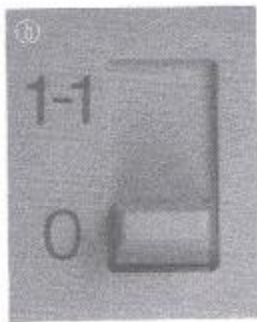

Select Levers

Used to knit Double Jacquard or Multi Coloured Jacquard.

- Ⓐ 1-1.....Every alternate needle knits Slip Stitch
- Ⓑ 0.....Every needle knits Stockinet

Left Lever works when the Carriage moves to the left.
Right Lever works when the Carriage moves to the right.



Russel Levers

Control needles in "D" position.

- Ⓐ NON-KNITTING POSITION, needles remain in D position.
- Ⓑ KNITTING POSITION, needles in D position will knit back to B position.

Left Lever works when the Carriage moves to the left.
Right Lever works when the Carriage moves to the right.

OPERATION TABLE

For Cast-on and main knitting, Operation Table gives settings and operation of machine.

PUNCH CARD KNITTER

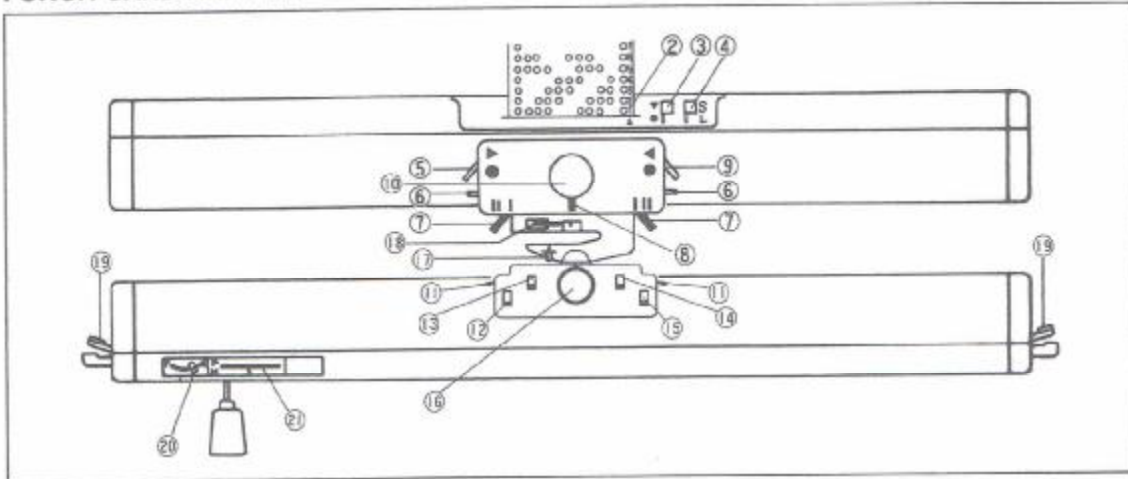

	①	Procedural order of the Operation Table	
PATTERN PANEL	②	Pattern Row Number	↓ — Set the Punch Card and lock at 1
	③	Stop Knob	
	④	L Knob	
KNITTER CARRIAGE	⑤	Side Lever (left)	
	⑥	Intarsia Levers (left & right)	Always set at 1 when using Ribber
	⑦	Russel Levers (left & right)	Always set at II, except when partial knitting
	⑧	Cam Lever	
	⑨	Side Lever (right)	
	⑩	Stitch Dial	
RIBBER CARRIAGE	⑪	Russel Levers (left & right)	Always set at =, except when partial knitting
	⑫	Select Lever (left)	
	⑬	Set Lever (left)	
	⑭	Set Lever (right)	
	⑮	Select Lever (right)	
	⑯	Stitch Dial	
RIBBER ARM	⑰	Auxiliary Yarn Feeder Lever	
	⑱	Driving Lever	→ — resting position ↑ — working position
RIBBER NEEDLE BED	⑲	Pile Levers (left & right)	↑ — upper position ↓ — lower position
	⑳	Half-Pitch Lever	
	㉑	Swing Indicator	
	㉒	Arrow mark indicates knitting direction of Carriage and number shows the number of rows required to be knitted.	

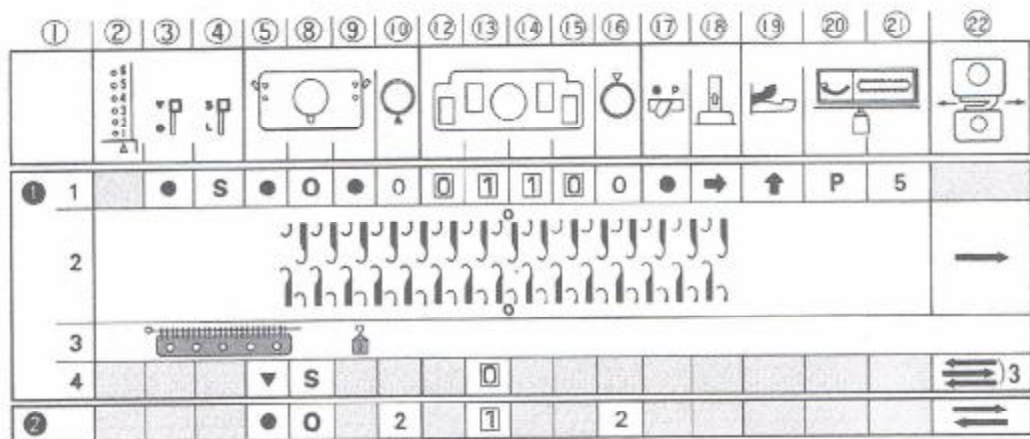

ELECTRONIC KNITTER

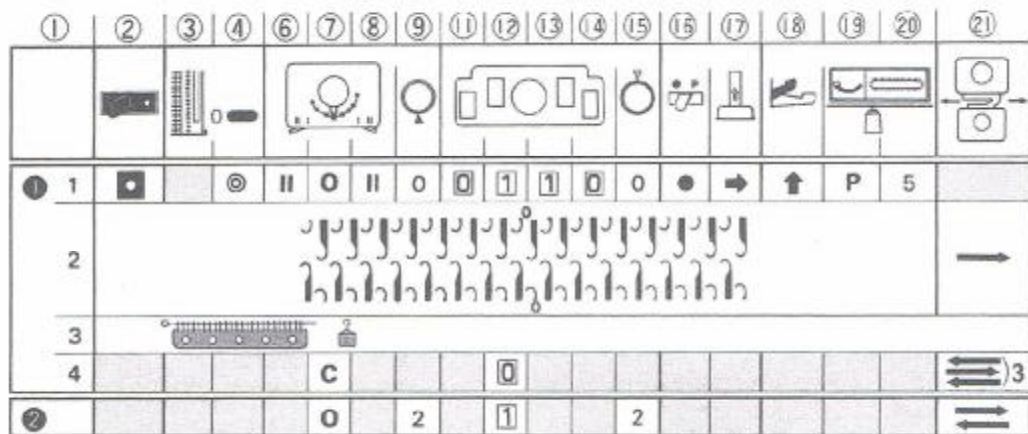
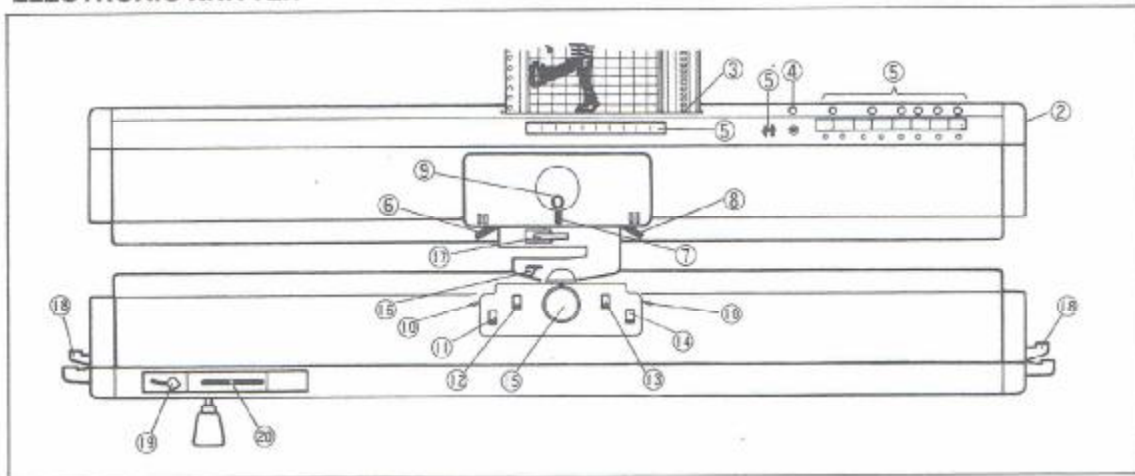

	①	Procedural order of the Operation Table	
	②	ON-OFF Switch	■ — Turn ON the machine
PATTERN PANEL	③	Pattern Row Number	↓ — Set the Pattern Card
	④	Inspection Switch	● — Light is ON ○ — Light is OFF
	⑤	Pattern Controls	Set Pattern Controls (Pattern Width, Direction Switch and Pattern Switches) as instructed.
KNITTER CARRIAGE	⑥	Russel Lever (left)	
	⑦	Cam Lever	
	⑧	Russel Lever (right)	
	⑨	Stitch Dial	
RIBBER CARRIAGE	⑩	Russel Lever (left & right)	Always set at = . except when partial knitting.
	⑪	Select Lever (left)	
	⑫	Set Lever (left)	
	⑬	Set Lever (right)	
	⑭	Select Lever (right)	
RIBBER ARM	⑮	Stitch Dial	
	⑯	Auxiliary Yarn Feeder Lever	
RIBBER NEEDLE BED	⑰	Driving Lever	→ — resting position ↑ — working position
	⑱	Pile Levers (left & right)	↑ — upper position ↓ — lower position
	⑲	Half-Pitch Lever	
	⑳	Swing Indicator	
	㉑	Arrow mark indicates knitting direction of Carriage and number shows the number of rows required to be knit.	

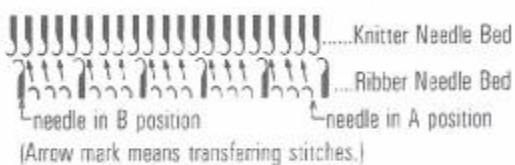

Move P Carriage without P Presser on Knitter to the left and back.



Move P Carriage without P Presser on Ribber to the right.



Move P Carriage with P Presser on Knitter to the left and back.



Move P Carriage with P Presser on Ribber to the right.

DOUBLE JACQUARD

Punch Card Knitter

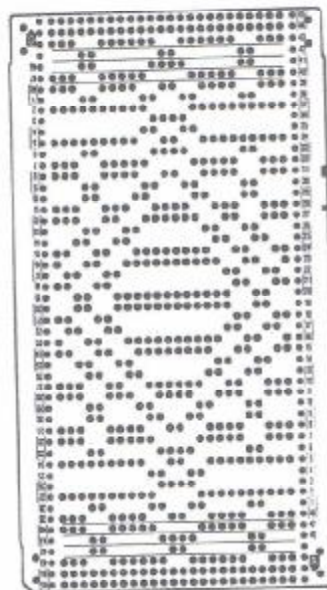

Double Jacquard is a fabric using a Punch Card, without floats of yarn across the back.

Using the Yarn Changer and a Punch Card, Pattern is made on Knitter side, with Cam Lever at SLIP, and Ribber knits Slip Stitch over alternate needle.

The sample is knitted with thin yarns, using the Punch Card given on the right.

Use Close Knit Bar.

① 1	●	S	①	①	①	①	●	O	●	O	①	①	①	①	●	→	↑	H	5	
2																			→	
3																				
4						▼	S	1		①			1							↔↔↔ 3
5	↓						O	▼	4	①			4							↔↔↔
6	Hook contrast yarn on Holder B.																			
② 1	1	▼		②	①		S			1-1	①	①	1-1				↑			↔↔↔
2	2	3		①	②															↔↔↔) 2
3	4			②	①															↔↔↔

* Set up Automatic Yarn Changer.

- A.....Holder A ①
 - B.....Holder B ①
 - C.....Holder C ②
 - D.....Holder D
- } positions of Holders

Punching a Card for Double Jacquard

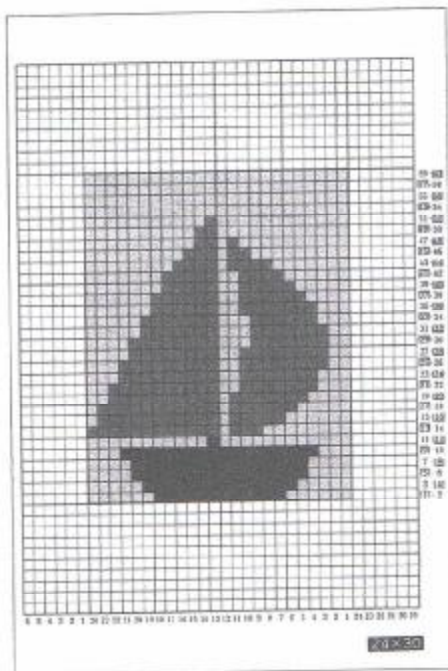

To punch a card for Double Jacquard using a blank card it is important to realise that each row of Double Jacquard pattern consists of two rows of slip stitch knitting. One is with background yarn and the other is with contrast yarn.

Follow the procedure below.

1. Draw your pattern on the graph paper supplied with the blank card set. Use the side marked **24 x 30**.
Maximum size of a pattern is 30 rows by 24 stitches to fit in a standard card, because one row of a pattern requires two rows of punching on the card.



IMPORTANT:

Even numbers of rows must be knitted in each colour, so the total number of rows for the pattern must also be an even number.



2. Mark the pattern from the graph paper onto the Card. Use the card with the rectangular numbers at the right edge.
- (1) Colour the first row of the Card, then the 4th and 5th rows missing 2nd and 3rd rows. Repeat in the same way throughout so that 2 rows of background yarn (coloured rows) alternate with 2 rows of contrast yarn. The division of coloured and plain rows is the same as the orange and blue rows on the check card.

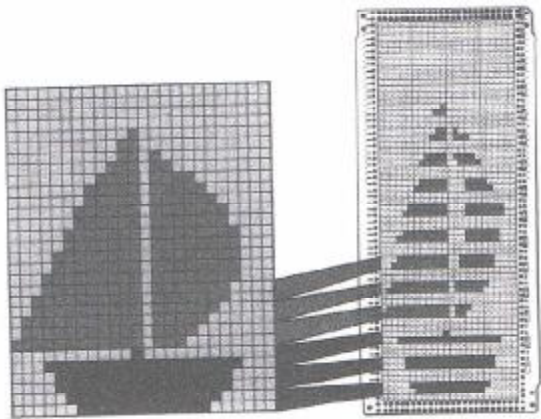

- (2) Mark the parts of contrast yarn on the first and second rows of the pattern onto the second and third rows of the Card (non-coloured rows) respectively.

In the same manner mark the parts of contrast yarn of every 2 rows of the pattern onto non-coloured rows of the Card.

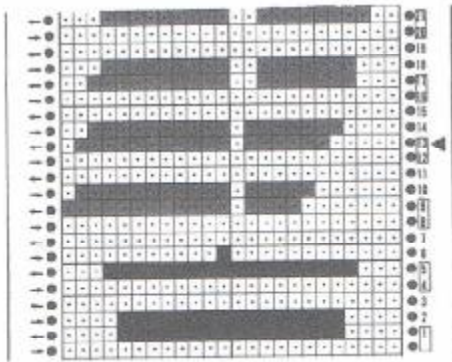

- (3) If more than two yarns are to be used for the pattern, mark the position to change the yarn (at the odd row number).

The row number to appear at the Pattern Panel while knitting corresponds to the row of five rows below.

Holder button for the yarn to be selected next is pushed when the Carriage is at right side, so the yarn changing mark must be positioned one row before the yarn is knitted.

3. Punch the sections marked.

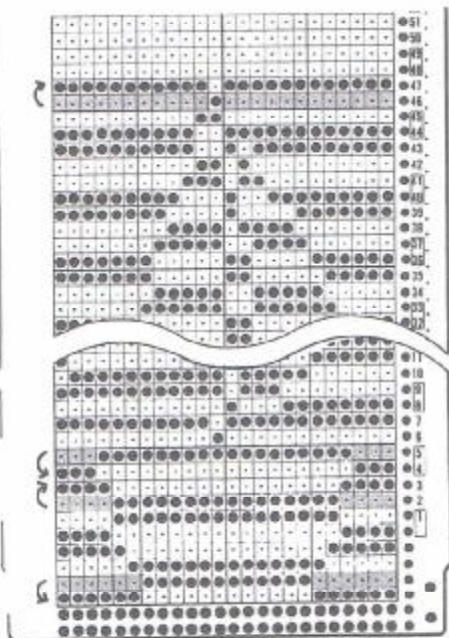

4. Punch the sections for background yarn which correspond to the non-punched sections of the pattern rows in the following manner.

- (1) For the first row, punch the sections which correspond to the non-punched sections on the second row.
- (2) Of the two consecutive coloured rows of the NP Card, punch the lower row to match the non-punched section of the row below, and punch the upper row to match the non-punched section of the row above.
- (3) The last row of punching must be for the background yarn so that it matches the first row punched on the card.

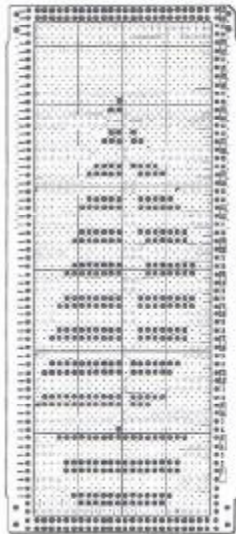
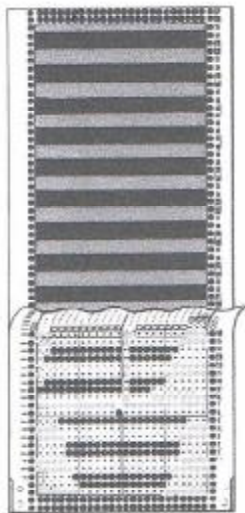

5. To check that the card is correctly punched, lay it over Check Card.

Make sure that the edges of punched card match the Check Card.

Punched holes in orange colour.....background yarn
 Punched holes in blue colour.....contrast yarn

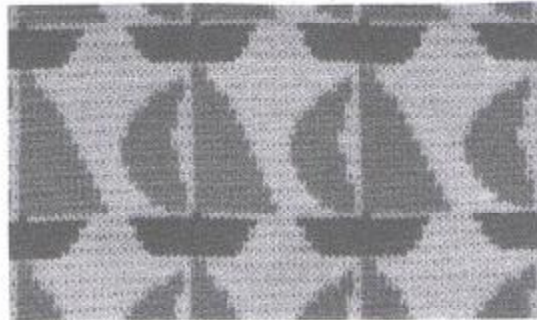

- 6 } Row numbers rectangled Knit with background yarn.
- 5 }
- 4 }
- 3 } Row numbers not rectangled Knit with contrast yarn.
- 2 }
- 1 }

Extra Pre-Punched Card sets for Double Jacquard (Series 73 & 74) are also available.

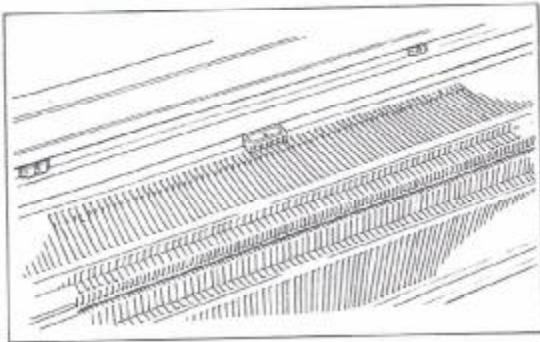

Cast-On

- ① — 1 Set the machine controls for the initial row.
- 2 Arrange needles and set Point Cams and Needle-1 Cam and knit from the left to the right.
- 3 Suspend Cast-on Comb with Weights.
- 4 Change machine controls for knitting subsequent 3 rows. Knit 3 rows.
- 5 Change machine controls and knit 1 row.
- 6 Hook contrast yarn on Holder B. Set Pattern Switches as shown on the left.

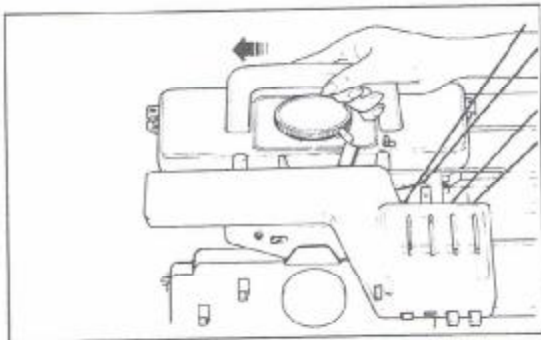

Main Knitting

- ② — 1 Change machine controls to knit Double Jacquard. Start knitting from the right to the left till Driving Lever hits Feeding Lever to change the yarn every two rows. (Two lights of the Switch 1 lights on alternately every two rows.) While knitting, change the yarns following the mark on the Notation Column by pushing the respective Holder Button when a buzzer sounds.

The Holder button holding the yarn to be selected next must be pushed when the Carriage is at the right side.

Shows the rows to knit in contrast colour.

Shows the rows to knit in background colour.

Push the Holder Button A when the buzzer sounds.

Push the Holder Button B when the buzzer sounds.

Push the Holder Button D when the buzzer sounds.

Push the Holder Button C when the buzzer sounds.

Push the Holder Button B when the buzzer sounds.

Notation Column
(When black mark appears, the buzzer sounds and the respective Holder Button has to be pushed.)

IMPORTANT In Double Jacquard, it takes two complete movements of the linked carriages to make one row of finished knitting on the main bed. The light by Pattern Switch 1 shows whether you are knitting background (right) or contrast (left).

To change pattern while knitting Double Jacquard

To change the pattern width or the Pattern Card.

- 1- Place the Carriage on the right and press Inspection Switch so the light comes on.
- 2- Re-set the Pattern Width Indicator or exchange the Pattern Card.
- 3- Press Inspection Switch so the light goes off.
- 4- Start knitting.

To re-set the Pattern Switches

1. Place the Carriage on the right.
- 2- Press the selected Pattern Switches so its light comes on or goes off.
- 3- Start knitting.

To change the positions of N1 Cam and/or the Point Cam on the side with the Carriage.

- 1- Place the Carriage on the right and press Inspection Switch so the light comes on.
- 2- Replace the N1 Cam and/or right Point Cam and disconnect the Ribber Carriage from the Arm.
- 3- Move the Knitter Carriage twice without knitting by pushing the Release Lever.
- 4- Press Inspection Switch so the light goes off.
- 5- Connect the Ribber Carriage and start knitting.

IMPORTANT!

Press Switch 6 just before knitting Double Jacquard and make sure that the right light of Switch 1 is on. (The Carriage is on the right.)

To knit Single Motif in Double Jacquard

- Set Point Cams and N1 Cam at the required positions and knit in the same manner as for ordinary Double Jacquard.

N.B. To change the positions of Point Cams and/or N1 Cam while knitting, refer the instructions above. When resetting the left Point Cam there will be no need to move the Knitter Carriage twice without knitting.

To knit Double Jacquard using Switch 3

- Press Switch 3 simultaneously with Switch 6 and knit in the same manner as for ordinary Double Jacquard.
- To use Pattern Switch 3 with its light on while knitting Double Jacquard, press Switch 3 so the light comes on with the Carriage on the right.

To knit Double Rib which looks the same as Double Jacquard

- 1- After the pattern in Double Jacquard has been completed press Inspection Switch so the light comes on.
- 2- Set Pattern Card at the blank position of the Card.
- 3- Press Inspection Switch to read the blank position.
- 4- Press Inspection Switch so the light comes on and continue to knit in the same manner as for ordinary Double Jacquard.
* If you knit Double Jacquard in combination with Double Rib the fabric effect is different.

If incorrectly knitted in the course of Double Jacquard

- 1- Unravel an even number of rows.
- 2- Press Inspection Switch so the light comes on and return the Pattern Card only half the number of rows unravelled. Press Inspection Switch so the light goes off.
- 3- Return the Row Counter and Pattern Paper the same number of rows unravelled.
- 4- Since two lights of Switch 1 light on alternately every two rows, reset Pattern Switch 1 according to the number of rows unravelled.
- 5- Re-arrange the Holder Buttons of the Yarn Changer to correspond with the mark in the Notation Column.
* Unless your Carriage has passed the second (last) Point Cam, there will be no need to touch the pattern mechanism or turn the Pattern Card back.
The only thing you have to do is to return the Carriage to the beginning of the row.

If incorrectly knitted in the course of Double Jacquard using Switch 3

- 1- In Double Jacquard using Pattern Switch 3, it takes 4 complete movements of the linked Carriages to knit one row of the Pattern Card, therefore unravel a multiple of four rows.
- 2- Press Inspection Switch so the light comes on and return the Pattern Card only quarter the number of rows unravelled.
- 3- Return the Row Counter and Pattern Paper the same number of rows unravelled.
- 4- Re-arrange the Holder Buttons of the Yarn Changer to correspond with the mark in the Notation Column.
* There will be no need to reset the Pattern Switch 1.

Cast-On

- ① — 1~4 Set machine controls, arrange needles as instructed, and work cast-on.
- 5 Change machine controls and knit 2 rows.
- 6 Hook contrast yarn on Holder B and C respectively.
Press Switch 3 so the light comes on.

Main Knitting

- ② — 1 Press Inspection Switch so the light comes off.
Set Cam Lever to "S" (SLIP).
Set Driving Lever to upright position.
Set Select Levers to and Set Levers to
Knit 1 row from the left to the right.
Bring Holder A to ② position and Holder B to ① position.
- 2 Knit 1 row from the right to the left.
Make sure that the Driving Lever operates Feeding Lever and the yarn in the Main Yarn Feeder is exchanged for the yarn in Holder B.
- 3 Knit 1 row from the left to the right and bring Holder C to ① position.
- 4 Knit 1 row from the right to the left.
- 5 Knit 1 row from the left to the right and bring Holder A to ① position.
- 6 Knit 1 row from the right to the left and repeat steps ② — 1~6.

HINTS WHEN KNITTING DOUBLE JACQUARD AND MULTI COLOURED JACQUARD

Select Levers

These are the additional mechanisms used to knit Double Jacquard and Multi Coloured Jacquard.

- * By setting Select Levers to **[1-1]** and Set Levers to **[0]**, every alternate needle knits Slip Stitch on the Ribber and stripes of one row will be formed on the wrong side of the fabric.
- * By setting Select Levers to **[0]** and Set Levers to **[1]**, every needle knits Stockinet on the Ribber and stripes of two rows will be formed on the wrong side of the fabric.

Be sure to have an even number of needles in working position on the Ribber at all times because every alternate needle, starting with the first needle nearest to the Carriage, knits Slip Stitch.



If an odd number of needles are in working position on the Ribber, the same needles will knit Slip Stitch every row.



Decreasing stitches at the edge

To decrease one stitch at both edges.

- 1- On the Ribber, transfer two stitches onto the adjacent needles at the side where the ribber needle lies to the outside of the knitter needle and push the empty needles back to A position.



N.B. Always decrease two stitches at one side instead of decreasing one stitch at each side.

- 2- On the Knitter, transfer both edge stitches onto their adjacent needles and push the empty needles back to A position.



To decrease several stitches at the edge.

You can decrease only on the Carriage side.

- 1- Set Half Pitch Lever to P.
- 2- Transfer the required even number of ribber stitches to their corresponding knitter needles.
N.B. If an odd number of stitches are required to be decreased, subtract or add one stitch to make the total decreased stitches an even number.
- 3- Cast off the required number of stitches to be decreased, using the yarn.
- 4- Set Half Pitch Lever to H to continue knitting.

Increasing stitches at the edge

To increase one stitch at both edges.

1- On the Ribber, push two empty needles from A to B position at the side where the knitter needle lies to the outside of the ribber needle.



N.B. Always increase two stitches at one side instead of increasing one stitch at each side.

2- On the knitter, push one empty needle from A to B position at each side.



To increase several stitches at the edge.

You can increase on the opposite side of the Carriage.

1- On the Knitter, push the required number of needles to B position.

2- On the Ribber, push the required even number of needles to B position.

N.B. If an odd number of stitches are required to be increased, subtract or add one stitch to make the total increased stitches an even number.

3- Knit one row.

4- Hang Edge Weight and continue to knit.

Partial Knitting

To decrease stitches.

* Follow the instructions given in the instruction book of Ribbing Attachment, provided that an even number of needles must be pushed to D position on the Ribber.

To increase stitches

* Follow the instructions given in the instruction book of Ribbing Attachment, provided that an even number of needles must be pushed back to B position on the Ribber.

Recommended Stitch Dial settings for each type of yarn

	thin yarn	light yarn	medium yarn
Knitter	2 — 4	4 — 6	7 — 8
Ribber	2 — 4	4 — 6	7 — 8

*For cast-on, refer to the Stitch Dial settings for Double Rib instructed in the instruction book of Ribbing Attachment.