

knitking

magazine



Season
Spanning
Collection

▼ Table ▼ Of ▼ Contents ▼

KNITKING MAGAZINE - VOLUME 23 NO. 1

○○○○ GENERAL INSTRUCTIONS	12
732 FAIR ISLE TURTLENECK	13
733 WOMENS COAT DRESS	14
734 WOMENS 2 PC. DOUBLE KNIT DRESS	15
735 WOMENS 3 PC. ENSEMBLE	16
736 BULKY TURTLENECK PULLOVER	19
737 MENS CABLE AND LACE PULLOVER	20
738 WOMENS NOTCH COLLAR SUIT	23
739 WOMENS 2 PC. LACE DRESS	25
740 UNISEX FAIR ISLE PULLOVER	27
○○○○ TECHNICAL TIPS	27
741 BOYS FAIR ISLE PULLOVER	28
742 WOMENS CUT-A-WAY JACKET	30
743 ANGORA AND PEBBLE PULLOVER	31
744 2 PC. PUFF SKIRT DRESS	33
○○○○ KNITKING NEWS	34
745 WOMENS 2 PC. DRESS	35
746 SHEATH DRESS	37
747 WOVEN VEST	38
748 SILKIE PULLOVER AND SKIRT	39
749 GIRLS GARTER CARRIAGE DRESS	41
750 SIDEWAYS KNITTED PULLOVER	42
751 WOMENS FAIR ISLE DRESS	43
752 MENS FAIR ISLE PULLOVER	45

732

▼ Luscious ▼

... color and the softness of Caprinae mixes with Pebble to make a delightful and simple to knit Pull-over. The Collar is separate so you can change the look at will. Make it on the Punch Card Bulky machine with Ribbing attachment.



▼ Editorial ▼

As we launch our 23rd year of publication with this exciting issue, we would like to take this opportunity to extend to you best wishes for a healthy and happy New Year.

Our outstanding selection of knitwear in this issue will provide patterns for the whole family. From children's sweaters to men's dress pullovers, fairisle to weaving, acrylics to mohair — Knitking covers the spectrum for your knitting and wearing pleasure!

Our designs are created with the utmost attention given to knitting technique, texture and color presentation. We recognize that many of you enjoy ordering your Knitking yarn kits as featured in our magazine. For those of you who desire a different color the solution is easy. With your Knitking yarn color cards (available for purchase) you can select the colors of your choice for any garment and order your kit in the colors you select. Let your imagination be your guide.

In this issue we have altered the shaping notations on our garment charts in order to make our garment patterns easier to follow and understand. For example, a reference that every 3 rows you are to decrease 1 stitch 5 times, is now written as 3-1-5x, rather than as 5x1 3. This change was made in response to recommendations by many of our subscribers; we hope that you will find it helpful.

Suzanne Str

▼ Travel ▼ Treasure ▼



735

You'll love the sumptuous softness and style of this 3-piece ensemble. Knitted in Stockinette stitch and Fair Isle. Repeat the design on the yoke of dress and lower edge of Skirt. Bands are ribbed in color stripes. Knit it on a standard Punch Card or Electronic machine with Ribber. Ice Cream is the yarn.

▼ Incredibly ▼ Lovely ▼

736

A mixture of Glace and Caprinae knitted in a Tuck and Skip stitch on the Punch Card Bulky machine make the perfect match in this beautiful pullover. The Collar and Bands are Ribbed.

▼ Cables, ▼ Lace, ▼ Garter ▼ Stitch ▼



737

... are all in this most attractive Man's Pullover. Experienced knitters will need a Compuknit III knitter with Garter Carriage to knit this one. The end result will more than please your man. The yarn is Venetia.

▼ Back ▼ To ▼ Basics ▼

738

Knit this two-piece Suit with Venetia on any standard machine. It's perfect for the office or any travel venture. Knitted in stockinette stitch, the straight skirt is topped with a sleek double breasted and notched collar Jacket.





739

... and an elegant scoop neckline in the back create a lovely two-piece dress you can wear forever. The simple lines are flattering to all figures. Knit it on a standard or electronic machine with Lace Carriage in our popular Venetia yarn.



740

741

A perfect trio of family Pullovers, for her, for him, for boys or girls. All are in sizes to cover your favorite family. A great Fair Isle Design that is quickly knitted on the Punch Card Bulky machine with Ribber. The yarn is Nordic.

▼ Kaleidoscope ▼ Of ▼ Color ▼



▼ Glorious ▼ Cut-A-Way ▼ Jacket ▼



742

... takes a favorite place in any knitted wardrobe. Light in weight and soft as a cloud, you'll wear it everywhere. Knitted from the top down for ease in shaping, the half Fishermans Rib can be made on any bulky machine with ribber. With Knit-king's twelve colors of Caprinae yarn, you'll find the perfect one for your jacket.

▼ General ▼ Instructions ▼

THE PRINTED INSTRUCTIONS

Follow the printed instructions or use them in combination with the Charts. When there is any question in the instructions, you have the Charts to show you how the section will look.

Be sure to READ AHEAD so that you KNOW what to do for the size you are knitting. In the shapings, where the number of stitches are the same but the number of times different, you might find shapings like this...3 sts. 1 (2) [3]x - so that for the first size you will bind off 3 sts. 1x, 2nd size 3 sts. 2x, 3rd size 3 sts. 3x. Sometimes the ROWS will be different for each size-so you must watch out for different row numbers.

Shoulder and neck shapings for the back section of a garment usually are shaped at the same time-so ALWAYS WATCH for the words, AT THE SAME TIME.

HOLDING STITCHES ON THE LEFT SIDE WHILE SHAPING THE RIGHT SIDE

There are different ways to hold stitches on one side while completing the other side. Usually, we tell you to bind off the center sts. for neck and put the left side into holding position while completing the right side. The easiest way, and really the best for beginners, is to take a piece of RAVEL CORD and hand knit the center neck stitches, pulling them back against the needle bed of machine to the "A" or out of work position. The stitches remain in the HOOKS of the needles so you are really only knitting them HALF WAY. With another color of Ravel Cord, knit the remaining sts. on the left side in the SAME WAY.

It is important to protect these held stitches in some way-so you can either hang a REVERSING BAR so that the EYES of the bar go BETWEEN the Gate Pegs on the machine and that the UPPER TIPS of bar only show above the needle bed, OR the simplest way is to use a piece of 1" masking tape and GENTLY place it beneath the knitting-right below the Gate Pegs. DO NOT press the tape, only enough pressure to hold it in place. This will prevent the Carriage (or Slide) from marking the held section.

It is VERY IMPORTANT that you mark the PATTERN ROW where you divide for the split for NECK (or SHOULDER) shaping. If you are using a PUNCH CARD, mark the card-if you are using an ELECTRONIC machine, mark the design window. Also take note of the Row number for the division. When you are ready to work the left section, bring the HELD stitches back to "B" (working) position by pulling each end of the Ravel Cord GENTLY and ripping it off. Be sure to align all needles straight in the "B" or knitting position.

Now you are ready to REFER TO YOUR OWN INSTRUCTION MANUAL for your machine to set the controls to begin knitting the left half. The neck stitches can be bound off after completing the right side, or you can leave them in hold until each side is finished. Bind off or remove them onto contrast waste yarn ready to be picked up for knitting a neckband or for other finishing.

FULL FASHION DECREASING OR INCREASING

For stockinette stitch, use the Full Fashion method for decreasing or increasing (except for regular cap shaping on sleeves where you decrease the edge stitch).

TO DECREASE: Hang the 3rd stitch onto the 2nd stitch, then move the end stitches in to fill the empty needle.

TO INCREASE: Move the 2nd end stitches 1 needle outward, then pick up the 3rd stitch from the row below and hang it onto empty needle.

PATTERN SYMBOLS

- () Symbol for 2nd size.
- [] Symbol for 3rd size.

There are up to 3 sizes given for Patterns in KNITKING MAGAZINE. For example, the Charts and printed instructions will show the cast on as - 124, first size, (132), second size, [140] third size.

- Needles in holding position.
- ✕ Needles back into working position
- Needle not used-in out of work position

Shaping symbols are given in the following order: Rows-Sts-Times. For example: 4-1-3x means: Every 4 rows decrease/increase 1 stitch 3 times. The shaping begins at the given row number.

THE SAMPLE SWATCH

Before you knit any garment, you must knit a sample swatch using the yarn you have chosen for your garment. If you do not get the correct Stitch and Row Gauge as given for a Pattern in KNITKING MAGAZINE, try different tensions. If you are using the specified yarn, you should be able to get the correct gauge using a smaller or larger tension. If you are using a different yarn, you may have to make several swatches, but the gauge is very important.

To make a sample swatch, Cast on 60 stitches with waste yarn and knit 6 rows. Mark the tension number for your sample swatch by making holes (you can do this with a Lace Carriage or by hand), 4 transfers for Tension 4, 6 transfers for Tension 6, etc. Knit 6 more rows.

Change to garment yarn and set Counter at 0. Knit 30 rows (in Stockinette stitch or Pattern stitch, according to the garment). With Contrast waste yarn, knit the 10th stitch FROM EACH SIDE by hand. Knit 30 rows. Change to waste yarn and knit 12 rows. Remove the sts. from the machine by pushing the Carriage (or Slide) across without yarn.

Pull and stretch the sample swatch both lengthwise and diagonally from corner to corner, then lengthwise again. Gently block the swatch (KNITTING PRESSING CLOTHS are great for this), or you can allow the sample to rest several hours or even over night so that the stitches can return to their basic form.

THE KNITKING STITCH/ROW GAUGE and STITCH/ROW CALCULATOR can be used to find the NUMBER OF STITCHES or ROWS TO 1". After knitting a sample swatch place the STITCH/ROW GAUGE horizontally with the START LINE on the INSIDE of LEFT stitch mark on sample. Keep it straight then read the number on the Gauge directly below the inside RIGHT mark on Gauge. This will give you the STITCH GAUGE TO 1". For instance, if the number is 8, then you have 8 stitches to 1". To find the ROWS TO 1", measure from the first row of garment yarn, VERTICALLY to the last row. Read the NUMBER from the LOWER EDGE of GAUGE, same as you did for stitches and if the number should be 14, you have 14 rows to 1".

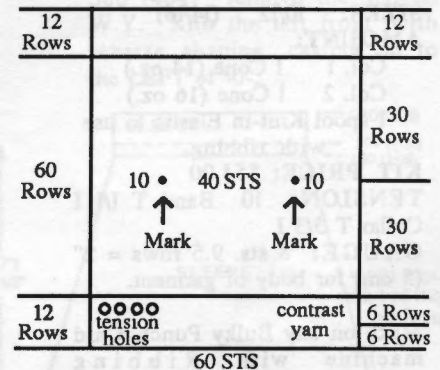

THE STITCH/ROW CALCULATOR will now give you the number of sts. or rows needed for a specific measurement. Line the ARROW to the number 8 (8 sts. to 1"). Should you need 20 inches of stitches, find the number 20 below and right above the 20 the Calculator shows 160 sts. It works the same way for rows using the Row Gauge.

FINISHING

Gently block all sections-For PULLOVERS, JACKETS, and DRESSES: Join the front to back at shoulders and sides. Sew sleeves together and set in. Hem lower edge and sleeve edges if needed. For a double neckband or armhole band, sew 1 edge to inside and 1 to the outside of neck or armhole. For a single ribbed band, sew 1 edge to the outside of neck or armhole edge. For a cardigan or jacket with buttonholes, finish buttonholes and sew on buttons.

PANTS: Join front to back at sides. Sew inside leg seams, then join to center front and back. Make hem at waistline and inset elastic. Hem lower edge of pant legs.

ABBREVIATIONS

BO	Bind Off	L.C.	Lace Carriage
Carr.	Carriage	MB	Main Bed
CO	Cast on	Nds.	Needles
Col.	Color	Pat.	Pattern
Dec.	Decrease	P	Purl
EON	Every Other Needle	RB	Ribber Bed
FNR	Full Needle Rib	R	Row
G.C.	Garner Carriage	St.	Stitch
G.S.	Garner Stitch	St. st.	Stockinette Stitch
HP	Holding Position	Strnd	Strand
Inc.	Increase	T	Tension
I.C.	Intarsia Carriage	W.Y.	Waste Yarn
K	Knit	WP	Working Position



WOMENS FAIRISLE TURTLENECK

YARN: Col. 1 Caprinae
Col. 2 Pebble

SIZES: 10/12 (14/16)

AMOUNT:

Col. 1 1 Cone (14 oz.)
Col. 2 1 Cone (16 oz.)
1 spool Knit-in Elastic to use with ribbing.

KIT PRICE: \$54.00
TENSION: 10 Band T 1/1 I
Collar T 3/3 I
GAUGE: 8 sts. 9.5 rows = 2" (5 cm) for body of garment.

Make on any Bulky Punch Card machine with Ribbing Attachment.
Use Punch Card No. 1 (every 2nd ndl. selection). for Fair Isle Design.

BACK: W.Y. cast on 80 (88) sts. After several rows end with 1 row Ravel Cord to the right. Counter at -0-. With Col. 1, knit 1 row then set pattern on next row to the right. Set for Fair Isle knitting and insert Col.

2 in -B- feeder and continue in Fair Isle Design. Knit to R 60 (66). **SHAPE ARMHOLE:** ON EACH SIDE, bind off 4 (6) sts. then on EVERY ROW decrease 1 st. 4 (5)x. Knit to R 102 (112). **SHAPE SHOULDER:** ON EACH SIDE, every 2 rows bind off 5 sts. 3x. After R 108 (118), bind off the remaining sts.

FRONT: Work the front the same as the back to R 90 (100). Bind off the center 12 (14) sts., put the ndls. on the left into holding position and complete the right side first. *ON NECK EDGE, on EVERY ROW decrease 1 st. 11x AND AT THE SAME TIME, after R 102 (112) SHAPE SHOULDER same as the back. Bring the ndls. on the left to WP, turn R Counter back to 90 (100) set pattern and complete the left half following instructions from *.

SLEEVE CUFFS: K1, P1 Rib. Bring 34 ndls. on MB to WP. Rehang the open sts. of sleeve with purl side facing you. You must bring the sleeve section UP BETWEEN THE RIBBER AND KNITTER in order to knit the cuff. Decrease the sts. evenly across. Use Col. 1 and knit-in elastic. Knit 1 row at T10 of MB, then transfer every 2nd st. to the ribber. With T 1/1/I, knit 20 rows. Knit one row across with T10 on MB and T5 on Ribber. Transfer Rib sts. to MB then latch off the crochet method.

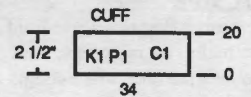

WAISTBAND: Make 2. K1/P1 Rib. Bring 76 (84) sts. to W.P. on the MB. Rehang the open sts. of waist with purl side facing same as described in sleeve cuff. Decrease the sts. evenly across. Use Col. 1 and knit-in elastic. Knit 1 row at T10 of MB, then transfer every 2nd st. to the ribber. With T1/1 I, knit 24 rows. Knit last row across with T10 on MB and T5 on Ribber. Transfer Rib sts. to MB then latch off the crochet method.

COLLAR: The Collar is optional - you can attach it or leave separated and use as a collar scarf. K1, P1 Rib. T 3/3 I. Cast on 100 (108) sts. at T 1/1 I. After selvedge change to T3/3 I and knit 50 rows. Knit one row across with MB T10, Ribber T 5. Transfer rib sts. to MB then latch off the crochet method.

FINISHING: See General Instructions.

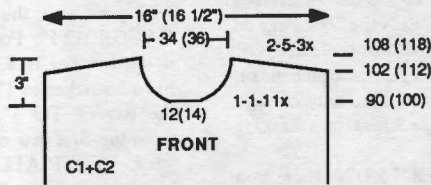

SLEEVES: W.Y. cast on 50(54) sts. Knit several rows ending with 1 row Ravel Cord to the right. Change to garment yarn, Counter at -0-. Knit 1 row with Col. 1 to set Pat. left to right.

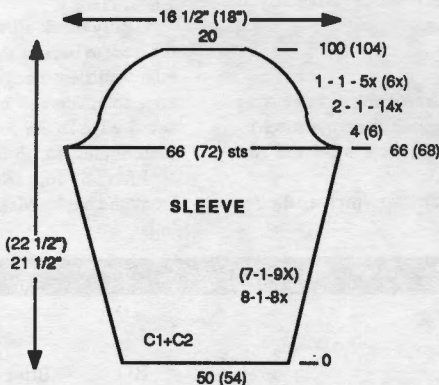

Insert Col. 2 in -B- feeder and set for Fair Isle Pat. same as before. ON EACH SIDE, every 8th row increase 1 st. 8x (every 7th row 1 st. 9x). After R 66 (68) **SHAPE CAP:** ON EACH SIDE, bind off 4 (6) sts. then every 2 rows decrease 1 st. 14x, then EVERY ROW 1 st. 5x (6x). After R 100 (104), bind off the remaining sts.

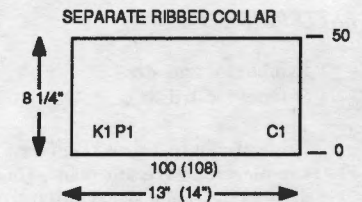
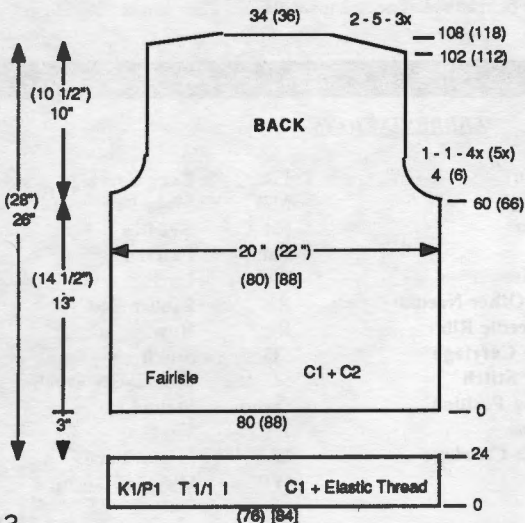

*732 Sweater Fair Isle Card

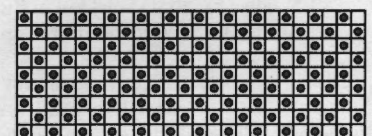



WOMENS COAT DRESS

YARN: Venetia
SIZES: 6/8 (10/12)
AMOUNT:
 Col. 1 Champagne 16 oz. 24 oz.
 Col. 2 Black 16 oz. 24 oz.
KIT PRICE: \$49.50 \$74.50
TENSION: 2.1 St. st. for Hem 3 - Pattern
GAUGE: 19 sts. 23 Rows = 2" (5 cm)
 6 Buttons - 1/2" diameter plus 1 decorative button for neckband, approximately 1 1/4".

Make on any standard Punch Card or Electronic machine. A Fair Isle vertical stripe pattern.

BACK: W.Y. cast on 172 (180) sts. After several rows end with 1 row Ravel Cord to the right. Change to Col. 1. Counter -0-. With T 2.1, knit 12 rows, setting Fair Isle Pattern

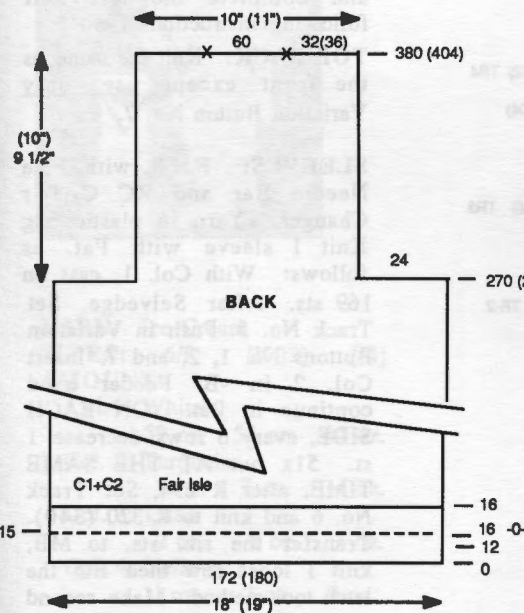

(2x1) on 12th row to the right. Insert Col. 2 in B Feeder and push in MC Button. LEAVE CARD ON STOP as this is a continuous verticle stripe. With T 3, knit to R 15, then with T 5, knit 1 row to the right. Change T back to 3 and put Counter at -0-. Knit to R 16, Pick up first row of Col. 1 and place onto ndls. to form hem. Continue in Pat. After R 270 (288), ON EACH SIDE BO 24 sts. for armhole. Knit to R 380 (400). Mark the 32 (36) sts. on each side for shoulder then remove each section separately onto W.Y.

RIGHT FRONT: W.Y. cast on 78 (82) sts. to the RIGHT OF -0-. After several rows end with 1 row Ravel Cord to the right. Change to Col. 1. Counter -0-. With T 2.1, knit 12 rows, setting Fair Isle Pattern on 12th row to the right. Insert Col. 2 in -B- Feeder and push in MC Button. Knit in Fair Isle same as for back. With T 3, knit to R 15, then with T 5, knit 1 row to the right. Change T back to 3 and put Counter at -0-. W.Y. cast on 33 sts. on the left. Knit 1 row St. st. with Col. 1 over

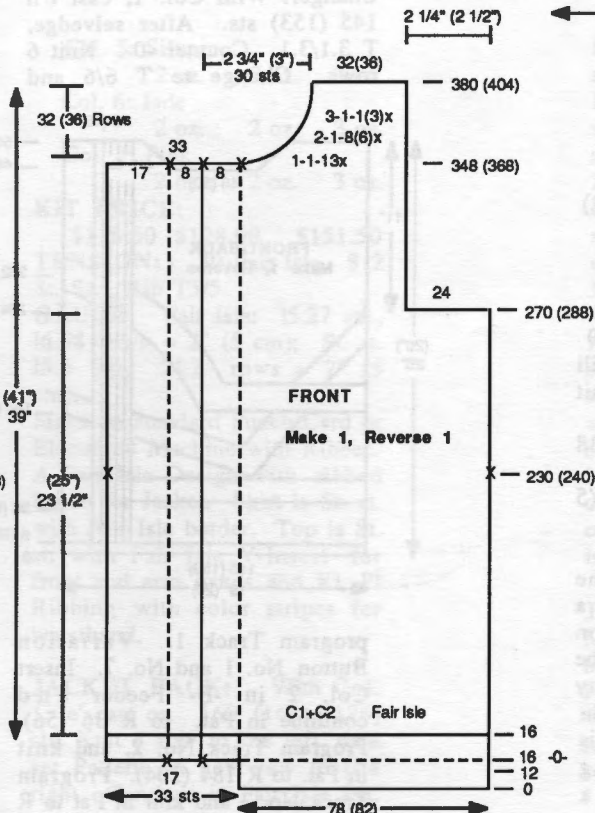

these new sts. Mark the 17th st. counting from the left edge with a bit of yarn for fold line. Set the 33 cast on sts. into pattern by hand then continue in Pat. Knit to R 16. Pick up first row of Col. 1 to form hem then continue knitting to R 230 (240) and mark the right edge and fold line on the left. as you did before with W.Y. Knit to R 270 (288) ON THE RIGHT, BO. 24 sts. then knit to R 348 (368). Mark the fold line on the left then remove the 33 sts. on a stitch holder or W.Y. Continue in Pat. and ON NECK EDGE, decrease 1 st. EVERY ROW 13x, 1 st. every 2 rows 8 (6)x, 1 st. every 3 rows 1 (3)x. After R 380 (404) remove the sts. on W.Y. Knit the left front with reverse shaping, casting on to the LEFT of -0-.

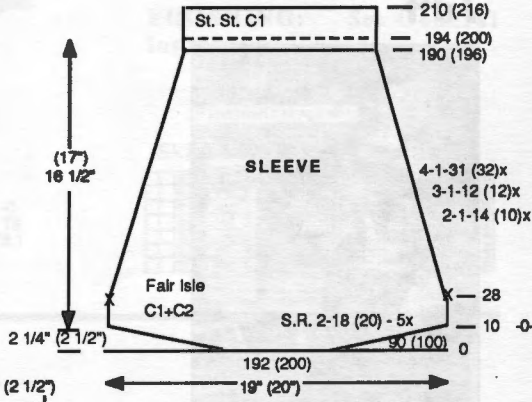

SLEEVES: Close both shoulders first. Bring 192 (200) ndls. to W.P. With purl side facing, pick up sts. evenly across armhole. SET THE STS. INTO PATTERN (you can use PART Buttons with no yarn) Work SHORT ROWS and be sure to always wrap inside ndl. in holding position using the color on the holding ndl. On opposite side of Carriage, on every 2nd row, bring to HP 18 (20) sts. 5x on each side. On opposite side of carriage set ndls from HP into Pattern. Knit across. Set remaining HP ndls into pattern. Counter at 0. Knit 28 rows. Counter at 0. ON EACH SIDE, every 2 rows decrease 1 st. 14 (10)x; then every 3 rows 1 st. 12 (12)x; every 4 rows 1 st. 31 (32)x. Knit R 190 (196) with T 5 for fold line. Change to T 3 and knit in Pat. to R 194 (200) Stop Pattern, at T 2.1, knit St. st. to R 210 (216) Knit

(continued from previous page)
1 very loose row and BO the latch tool method.

NECKBAND: Shoulders and sleeves must be completed. Bring 152 ndls. to W.P. With wrong side facing, pick up sts. around neckline as follows. Leaving 17 sts. on each side for facing. Neckband sts. should be picked up as follows: 46 sts. for right front, 60 sts. for back

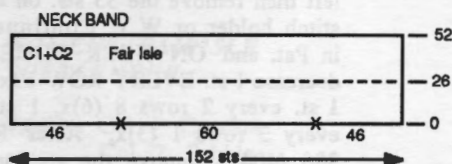

neck, 46 sts. for left front. Set in Pattern. T 3. After R 26, mark each side for center fold. Knit to R 52. Knit 1 loose row then bind off the latch tool method.

FINISHING: See General Instructions. Fold bands to the inside and sew in place. Weave the open sts. together at lower edge of front bands. Place right front over left front then leave approximately 7" free on lower edge then close the opening up to the marked row. Sew buttons along left front band on the inside approximately 3" apart. Weave open edges of neckband. Sew a decorative button on the outside of neckband. Make

loops for buttonholes with a crochet hook and sew the loops opposite the buttons on the inside of right band.

Dress Pattern Card - #733

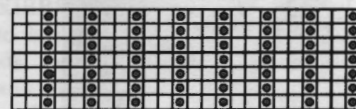

734



**WOMENS 2 PC
DOUBLE KNIT DRESS**

YARN: Venetia
SIZES: 6/8 (10/12)
AMOUNT:
Col. 1: Black 24 oz. 32 oz.
Col. 2: Champagne 24 oz. 32 oz.
KIT PRICE: \$72.00 \$96.00
TENSION: F.N.R. 6/6 (Lili Buttons) for Top Double Knit Design; T 3 for Skirt
GAUGE: F.N.R. 15 sts., 28 rows = 2" (5 cm)
Skirt: 19 sts. 23 rows = 2" (5 cm)

complimentary printed copy of the design, which appears on KnitKing's Floppy Disk (this issue), please send a self-addressed stamped envelope with your request.

TOP FRONT: Set each cone of yarn into a plastic bag. F.N.R. Be sure to use the Fine Needle Bar and Ribber Color Changer. With Col. 1, cast on 145 (153) sts. After selvedge, T 3.1/3.1. Counter -0-. Knit 6 rows. Change to T 6/6 and

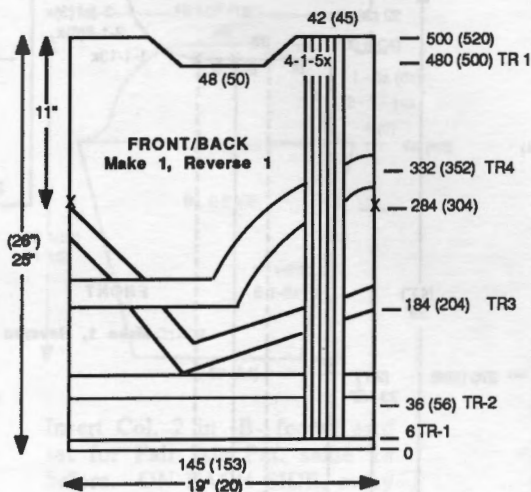

program Track 1. Variation Button No. 1 and No. 7. Insert Col. 2 in -B- Feeder and continue in Pat. to R 36 (56). Program Track No. 2. and knit in Pat. to R 184 (204). Program Track No. 3 and knit in Pat to R

284 (304) then mark each side with W.Y. for setting in sleeve. Continue in Pat. to R 332 (352). Program Track No. 4 and knit in Pat. to R 480 (500). Program Track No. 1 again. BO the center 48 (50) sts., put the ndls. on the left into HP and complete the right side first. Push the M Key. *ON NECK EDGE, every 4 rows decrease 1 st. 5x. After R 500 (520), transfer the rib sts. to MB. Knit 1 loose row then BO the latch tool method. Bring the Ndl. on the left to WP, PUSH IN BOTH PART BUTTONS AND PUSH THE M KEY. Push the Carr. across from left to right to select ndls. Insert Yarn, release the Part Buttons and complete the left half following instructions from *.

TOP BACK: Knit the same as the front except use only Variation Button No. 7.

SLEEVES: F.N.R. with Fine Needle Bar and RC Color Changer. Yarn in plastic bag Knit 1 sleeve with Pat. as follows: With Col. 1, cast on 169 sts. After Selvedge, Set Track No. 5. Push in Variation Buttons No. 1, 2, and 7. Insert Col. 2 in -B- Feeder and continue in Pat. ON EACH SIDE, every 6 rows decrease 1 st. 51x but AT THE SAME TIME, after R 294, Set Track No. 6 and knit to R 320 (340). Transfer the rib. sts. to MB, knit 1 loose row then BO the latch tool method. Make second

sleeve without pattern, using only the No. 7 (KRC) variation button.

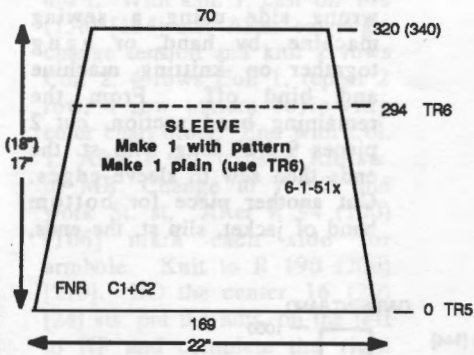

CUFF: FNR T3.1/3.1

Bring 48 (52) ndls to WP. After selvedge, knit 10 rows. Transfer sts. to MB. With purl side facing, pick up sts. gathering evenly across lower edge of sleeve. Knit 1 loose row then BO the latch tool method.

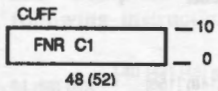

NECKBAND: F.N.R. T3.1/3.1 Fine Needle Bar. Close 1 shoulder first. Bring 135 (139) ndls. to WP. After selvedge, knit 10 rows.

Transfer rib sts. to MB. With purl side facing, pick up sts. evenly around neckline. Knit 1 loose row then BO the latch tool method.

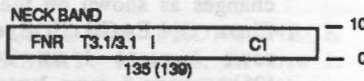

SKIRT: Make 2 sections. W.Y. cast on 170 (180) sts. Std. machine. After several rows, end with 1 row Ravel Cord to the right. With Col. 1, T 2.1, knit 11 rows then set Fair Isle Pat. on next row to the

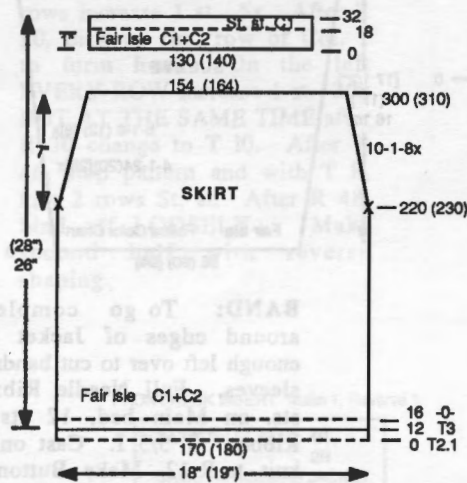

right. If using Punch Card pattern, put card on stop. Insert Col. 2 in -B- Feeder and with T 3, knit 4 rows Pat. COUNTER - 0-. Continue in Fair Isle. After R 16, pick up first row of garment to form hem. Cont. in Fair Isle with T3. After R 220 (230), mark each side and ON EACH SIDE, every 10 rows decrease 1 st. 8x. After R 300 (310), remove the sts. on contrast waste yarn. Bring 130 (140) ndls. to W.P. With purl side facing, hang the open sts. of one waist section onto these ndls., decreasing evenly across. Set Pattern. T 3. Knit 18 rows. Stop Pat. and knit 14 rows. After R 32, pick up first row of band to form hem. Knit 1 loose row then BO the latch tool method.

FINISHING: See General Instructions.

Skirt Pattern Card - #734

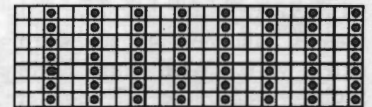

735



- Col. 5: Silver
2 oz. 2 oz. 3 oz.
- Col. 6: Jade
2 oz. 2 oz. 3 oz.
- Col. 7: Pink
2 oz. 2 oz. 3 oz.

KIT PRICE:

\$118.50 \$128.00 \$151.50

TENSION: 10 Fair Isle, 8.2 St. St., Rib T5/5

GAUGE: Fair Isle: 15.27 sts., 16.58 rows = 2" (5 cm); St. st. 15.6 sts. 21.2 rows = 2" (5 cm).

Make on standard Punch Card or Electronic Machine with Ribber. A Fair Isle Design with ribbed bands for Jacket. Skirt is St. st. with Fair Isle border. Top is St. st. with Fair Isle V-insert for front and arm bands and KI, PI Ribbing with color stripes for waistband.

JACKET BACK: With Col. 1, 'e' cast on 160 (168) [176] sts. Knit 1 row to the left then set Pattern on next row to the right. Continue in Fair Isle Pat.

following the changes in color as shown on the Chart. After R 124 (130) [136] mark each side with bit of contrast yarn for setting in sleeves. Knit to row 208 (218) [228]. Bind off the center 22 (24) [26] sts. Put the ndls. on the left into HP and complete the right side first. Mark down Pattern Row number. *SHAPE SHOULDER AND NECK AT THE SAME TIME. For shoulder, every 2 rows BO 18 sts. 3x (19 sts. 3x) [20 sts. 3x] and for neck, every 2 rows BO 5 sts. 3x. Bring the ndls. on the left to working position. Set correct row of pattern then complete the left half following instructions from *.

JACKET FRONT:

Make 1, Reverse 1. **MAKE 2 POCKET LININGS FIRST.** With Col. 1, 'e' cast on 47 sts. With T 9.1, knit 46 rows St. st. Remove the sts. on contrast waste yarn.

(continued next page)

YARN: Ice Cream
SIZES: 6/8 (10/12) [14]
AMOUNT:

- Col. 1: White
52 oz. 56 oz. 64 oz.
- Col. 2: Turquoise
3 oz. 3 oz. 4 oz.
- Col. 3: Lilac
2 oz. 2 oz. 3 oz.
- Col. 4: Yellow
1 oz. 2 oz. 2 oz.

(continued from previous page)

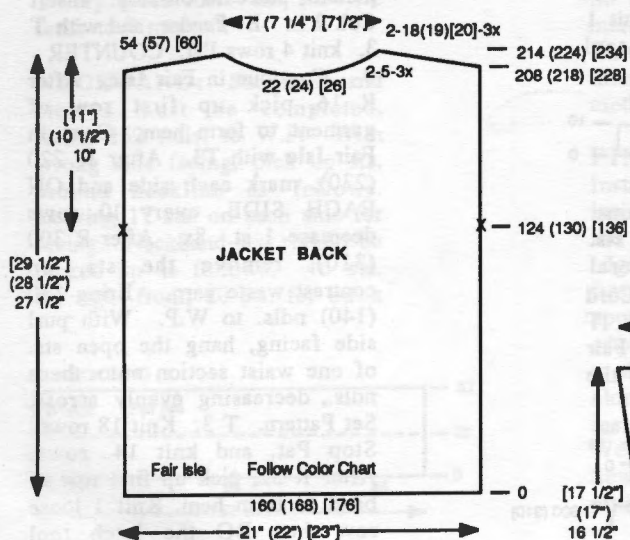

Right Front: With Col. 1, 'e' cast on 84 (88) [92] sts. Knit 1 row to the left then set Pat. on next row to the right. Continue in Fair Isle Pat. following color changes as shown on the Chart. Knit to R 52 (56) [60]. Leave 23 (25) [27] sts. on the left then BO the next 47 sts. with extra yarn. With purl side facing, hang the 47 pocket lining sts. onto the empty needles. Continue in Pat. across all ndls. Knit to R 124 (130) [136]. Mark each side with bit of contrast yarn. **ON THE LEFT, SHAPE NECK:** every 3 rows decrease 1 st. 16 (14) [14]x then every 4 rows decrease 1 st. 10 (13) [14]x. After R 208 (218) [228] **SHAPE SHOULDER** same as the back. Knit the left front with reverse shaping, making sure the pocket lining is placed counting from the right edge.

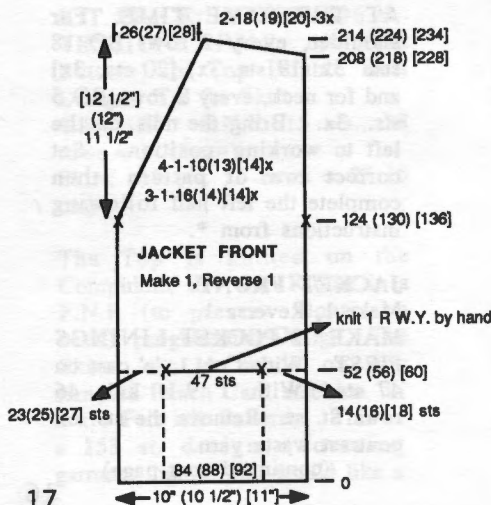

SLEEVES: With Col. 1, 'e' cast on 86 (90) [94] sts. Knit 1 row to the left then set Pat. on next row to the right. Continue in Fair Isle Pat. following color changes as shown on the Color Chart. **ON EACH SIDE,** every 4 rows increase 1 st. 24 (20) [25]x, every 5 rows 1 st. 8 (12) [8]x. After R 136 (140) [144], Bind off loosely or remove on W.Y.

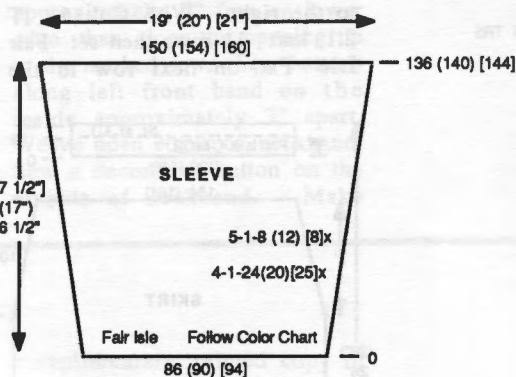

BAND: To go completely around edges of Jacket with enough left over to cut bands for sleeves. Full Needle Rib: 13 sts. on Main bed, 12 sts. on Ribber. T 5/5 I. Cast on and knit to R 12. Make Buttonhole over sts. 6,7,8,9. REPEAT THE BUTTONHOLE over same needles after Rows 42 (46) [48], 76 (80) [84], 108 (114) [120], 144 (148) [156]. Knit to R 214 (222) [236] Mark each side for shoulder, knit to R 244 (252) [270]. Mark each side for center neck. Continue to knit to

CUFF BAND (Portion of Garment Band)

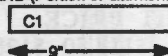

R 1000. Transfer rib sts. to MB. BO.

POCKET BAND: Make 2. Full Needle Rib. 10 sts. on MB, 9 sts. on Ribber. T 5/5 I. Knit 54 rows. Transfer rib sts. to MB. BO.

POCKET BAND Make 2

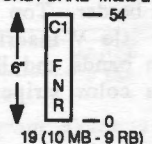

INSIDE POCKET Make 2

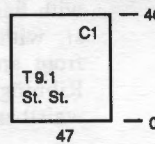

FINISHING: See General Instructions. Sew Pocket Band to pocket opening. Sew pocket lining on the inside. *First* baste or pin band around outside edge

of jacket, with buttonholes on the right side of jacket. You can sew the band in place from the wrong side using a sewing machine, by hand, or hang together on knitting machine and bind off. From the remaining band section, cut 2 pieces 9 1/2" long, slip st. the ends then sew to sleeve edges. Cut another piece for bottom band of jacket, slip st. the ends,

GARMENT BAND

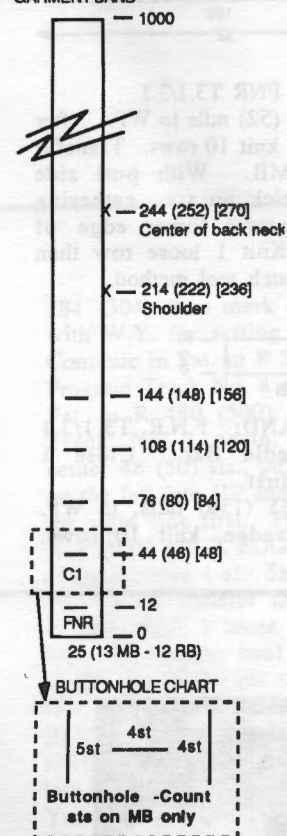

then sew to lower edge of jacket. Miter corners and stitch back where lower edge meets button/buttonhole band. Finish buttonholes and sew on buttons.

COLOR CHART - MAIN COLOR: C1-White throughout

Col. No.	No. Rows	Color Name
2	14	Turquoise
3	10	Lilac
4	4	Yellow
5	12	Silver
6	8	Jade
7	8	Pink
2	12	Turquoise
3	8	Lilac
4	4	Yellow
5	12	Silver
6	8	Jade
7	6	Pink

Repeat color chart

PULLOVER BACK: K1, P1 Ribbing. with color stripes. T 4/4 I. With Col. 1, cast on 148 (156) [164] sts. After selvedge, change tension and knit 2 rows Col. 2, 4 rows Col. 1, repeat 2 row, 4 row pattern following color chart order. End with Col. 1. After R 40, transfer Rib sts. to MB. Change to T 8.2. and work St. st. After R 94 (100) [106] mark each side for armhole. Knit to R 190 (200) [210]. BO the center 16 (20) [24] sts. put the ndls. on the left to HP and complete the right side first. *SHAPE NECK AND SHOULDER AT THE SAME TIME. For Shoulder every 2 rows BO 10 sts. 3x, then BO the remaining shoulder sts. For Neck, every 2 rows BO 3 sts. 4x. Bring the ndls. on the left to working position, turn Row Counter back to 190 (200) [210] and complete the left half following instructions from *.

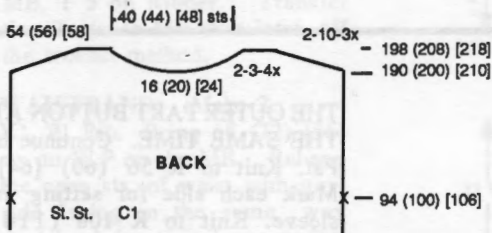

PULLOVER FRONT: Work the front the same as the back to R 82 (88) [94]. Divide in the center and put the ndls. on the left to HP and complete the right side first. *ON NECK SIDE, decrease 1 st. every 2 rows 43 (45) [47]x; then every 3 rows 1 st. 10x. AT THE SAME TIME, mark R 94 (100) [106] with a bit of yarn for armhole. After R 198 (208) [218] bind off (or remove on W.Y.) the remaining

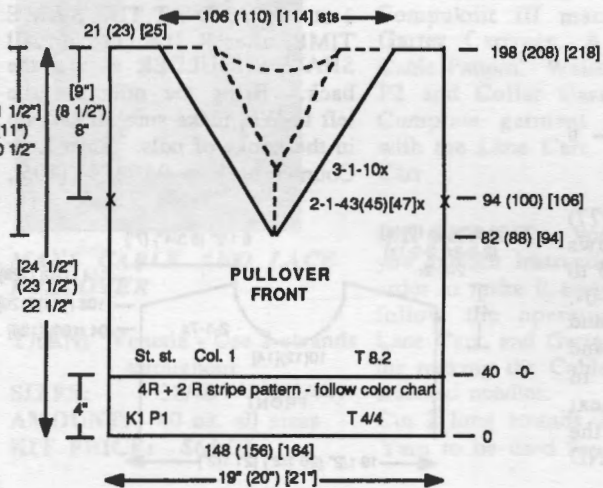
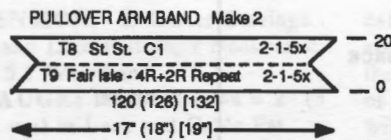
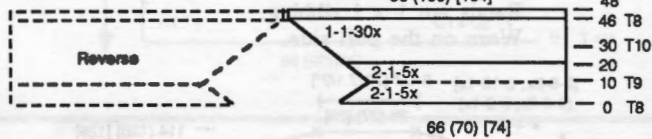

sts. Bring the ndls. on the left back to WP. Turn Row Counter back to 82 (88) [94] and complete the left half following instructions from *

PULLOVER FRONT NECK INSERT: Make 1, Reverse 1. W.Y. cast on 66 (70) [74] sts. to the right of -0-. Knit several rows ending with 1 row Ravel Cord to the right. Counter 0. With Col. 1 and T 8, work St. st. On the left, every 2 rows decrease 1 st. 5x. After R 10, change to T 9, Set Fair Isle Pattern and on the left, every 2 rows increase 1 st. 5x. After R 20, pick up first row of Col. 1 to form hem. On the left EVERY ROW increase 1 st. 30x BUT AT THE SAME TIME after R 30 change to T 10. After R 46, stop pattern and with T 8, knit 2 rows St. st. After R 48, bind off LOOSELY. Make second half with reverse shaping.

SKIRT FRONT: W.Y. cast on 142 (150) [160] sts.. Knit several rows ending with 1 row Ravel Cord to the right. With T 8 and Col. 1, knit 10 rows, setting Pattern on 10th row to the right. Counter -0-. After R 10, pick up first row held on W.Y. to form hem. Continue in Pat. and ON EACH SIDE, every

Fair Isle - Pattern #735
24 sts - 100 rows

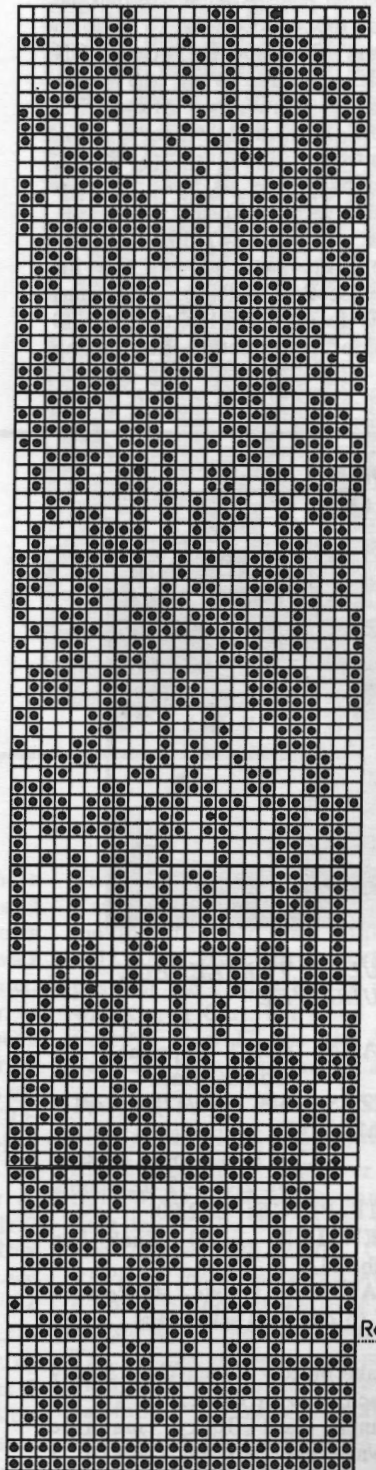

ARMBANDS: Sew in front insert first then close shoulders. With purl side facing, pick up 120 (126) [132] sts. from armhole. With T 9, knit 2 rows St. st. setting pattern on 2nd row. ON EACH SIDE, decrease 1 st. every 2 rows 5x. After R 12, stop pattern and with T 8, knit St. st. and ON EACH SIDE, increase 1 st. every 2 rows 5x. After R 22, pick up first row of band and BO LOOSELY.

FINISHING: See General Instructions. Work 1 row single crochet across back neck then 1 row reverse single crochet.

(continued next page)

(continued from previous page)
 10 rows increase 1 st. 3x. After R 36, Stop Pat. and with T 8.2 and Col. 1, continue in St. st. Knit to R 200 (210) [220]. ON EACH SIDE, every 10 rows decrease 1 st. 7x. After R 270 (280) [290] remove the sts. onto W.Y.

SKIRT BACK: W.Y. cast on 82 (86) [90] sts. Knit several rows ending with 1 row Ravel Cord to the right. With T 8 and Col. 1, knit 10 rows, setting Pattern on 10th row to the right. Counter -0-. After R 10, pick up first row held on W.Y. to form hem. Continue in Pat and ON THE LEFT, every 10 rows increase 1 st. 3x. After R 36, stop Pat. and with T 8.2, continue in St. st. to R 56. Remove these sts. onto contrast waste yarn. To the right of -0-, cast on 82 (86) [90] sts. and work the same as you did for first section to R 56. With purl side facing, overlap the first 10 sts. of first section and rehang

all sts. Counter at 56. Continue in St. st. the same as front skirt.

WAISTBAND: Make 2. Bring 92 (100) [110] ndls. to WP. With purl side facing, hang the open sts. of skirt waist onto these ndls. decreasing evenly across. With T 8.2 and Col. 1,

knit 28 rows. Pick up first row of band and hang onto same ndls. Knit 1 loose row then BO the latch tool method.

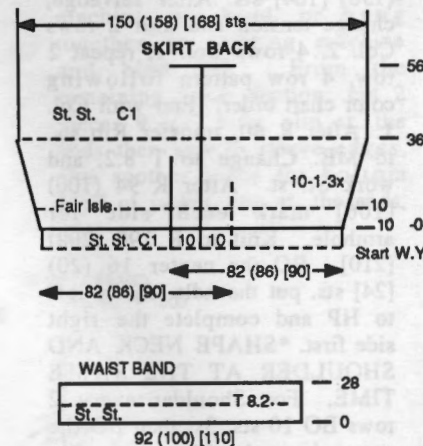
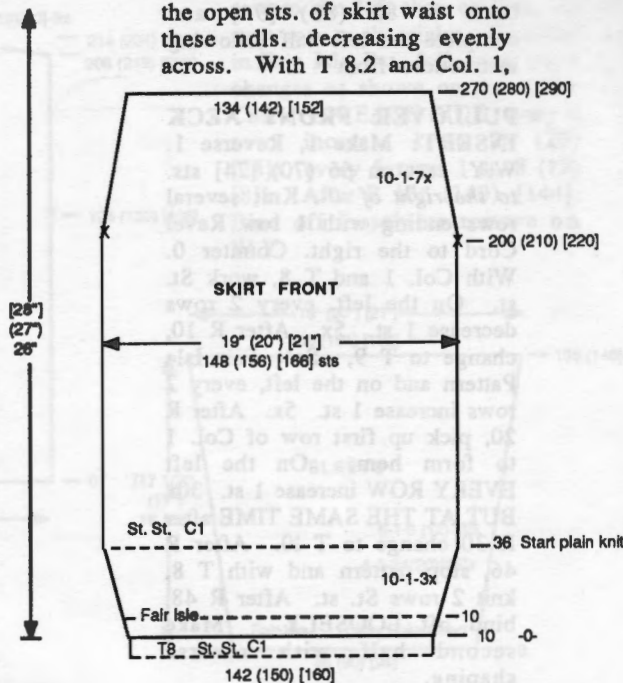

FINISHING: See General Instructions. Work 4 rows single crochet down each side of slit then turn to the inside and sew in place.

736



BULKY TURTLENECK PULLOVER

YARN: Col. 1 Caprinae
 Col. 2 Glace
SIZES: 6/8 (10/12) [14/16]
AMOUNT:
 Col. 1: 2 cones all sizes
 Col. 2: 5-2 oz. spools
KIT PRICE: \$62.00
TENSION: 10 Tuck Pat.
 Rib. T1/1 II
GAUGE: 7.5 sts. 10 Rows = 2" (5 cm) in Tuck st. Pat.

Make on any Punch Card Bulky machine with Ribber. Punch Card Bulky machine owners use Tuck Pat. Card No. 7 included with machine. Other

machine owners, punch card. Body of Pullover is a Tuck and Skip st. Pat. with Col. 1 in -A-Feeder and Col. 2 for Plating. Bands are 1 x 1 ribbing. Worn on the purl side.

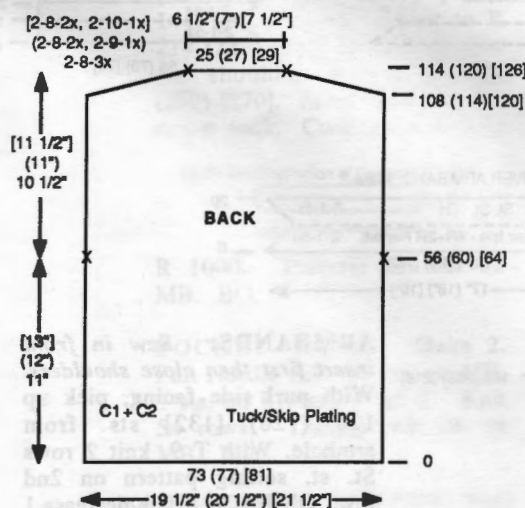

BACK: W.Y. cast on 73 (77) [81] sts. Knit several rows ending with 1 row Ravel Cord to the right. Counter at -0-. Change to garment yarns and with Col. 1 as main yarn and Col. 2 as plating yarn, knit to the left then set Pat. on next row to the right. Push in the OUTER TUCK BUTTON AND

THE OUTER PART BUTTON AT THE SAME TIME. Continue in Pat. Knit to R 56 (60) [64]. Mark each side for setting in sleeve. Knit to R 108 (114) [120]. **SHAPE SHOULDER:** On each side every 2 rows, bind off 8 sts. 3x, (8 sts. 2x, 9 sts. 1x) [8 sts. 2x, 10 sts. 1x]. After R 114 (120) [126] bind off the remaining sts.

FRONT: Work the front the same as the back to R 94 (100) [106]. Bind off the center 10 (12) [14] sts. put the ndls. on the left into HP and complete the right side first. Mark down Pat. row number. *ON NECK EDGE, every two rows decrease 1 st. 7x AND AT THE SAME TIME, after R 108 (114) [120] SHAPE SHOULDER same as the back. Bring the ndls. on the left to WP, make sure all sts. are in the hooks of ndls. Turn Row Counter back to 94 (100) [106],

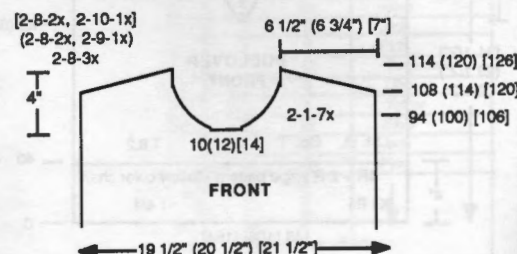

set Pat to correct row and complete the left half following instructions from *.

SLEEVE: W. Y. cast on 56 (60) [64] sts. same as back/front. After Ravel Cord Row set Pattern same as before. ON EACH SIDE, every 7 rows increase 1 st. 9 (10) [11] x. After R 70 (76) [82], mark center st. then remove on W.Y.

SLEEVE CUFFS: K1, P1 Rib. Bring 32 (36) [40] ndls. on MB to WP. Rehang the open sts. of sleeve with purl side facing you. You must bring the sleeve section UP BETWEEN THE KNITTER AND RIBBER in order to knit the cuff. Decrease the sts. evenly across. Use 1 strand Col. 1 and 1 strand Col. 2 together. Knit 1 row T 10 on MB then transfer every 2nd st. to the ribber. T 1/1 II. Knit 20 rows. Knit 1 row with T 10 on

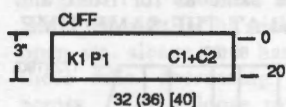

MB, T 5 on Ribber. Transfer the rib sts. to MB then latch off the crochet method.

WAISTBAND: Make 2. K1, P1 Rib. Bring 68 (72) [86] sts. to W.P on the MB. Rehang the open sts. of waist with purl side facing in the same way explained for the sleeve cuffs. Decrease the sts. evenly across. With 1 strand Col. 1 and Col. 2,

knit 1 row T 10 on MB then transfer every 2nd st. to Ribber. T 1/1 II. Knit 24 rows. Knit 1 row T 10 on MB, T 5 on Ribber then transfer the rib sts. to MB and latch off the crochet method

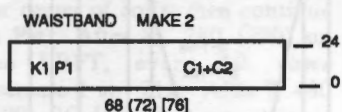

COLLAR: Close 1 shoulder first. K1, P1 Rib. Change tensions as directed. Ribber slide on I. With Col. 1 and 2 together, cast on 86 (90) [94] sts. After selvedge, with T 4/4, knit 20 rows, T 3/3, knit 10 rows, T 2/2, knit 10 rows. T 1/1, knit 10 rows. Transfer Rib sts. to MB then with knit side facing, pick up sts. around

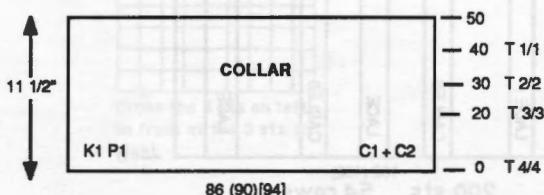
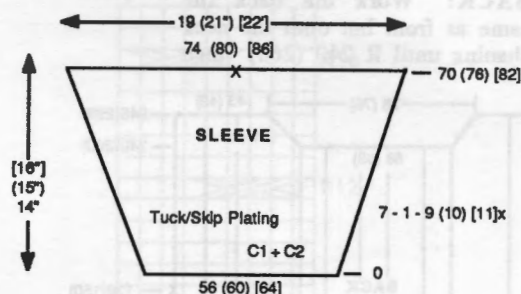

neckline and knit 1 very loose row (T 10) and latch off the crochet method.

FINISHING: See General Instructions. Make a 1 1/2" pleat at each shoulder, folding over toward the sleeve. With Glace, work large feather stitching for approximately 8" down toward the armhole.

Pattern #736

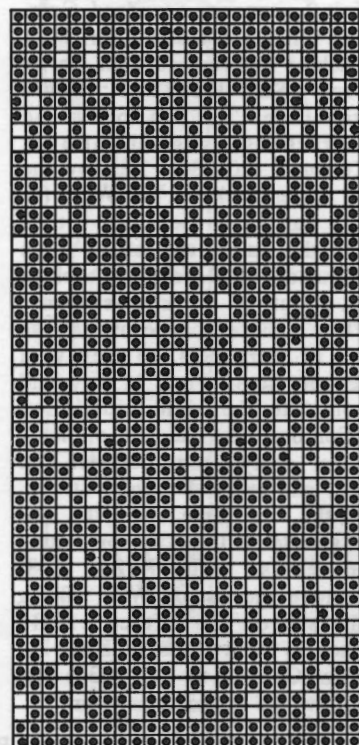

Card No. 7

737

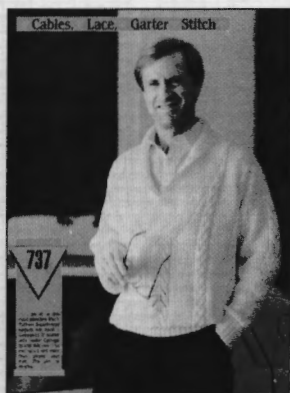

MANS CABLE AND LACE PULLOVER

YARN: Venetia - Use 2 strands throughout
SIZES: 38/40 (42/44)
AMOUNT: 40 oz. all sizes
KIT PRICE: \$64.00

TENSION: 10 Garter Carriage and Lace Pattern; 7 Neckband; 5.1 Waistband
GAUGE: 13 sts. 21 rows = 2" (5 cm) in Lace and Cable Pat.
 For **experienced** knitters with Compuknit III machines and Garter Carriage. A Lace and Cable Pattern. Waistband is K2, P2 and Collar Garter Stitch. Complete garment is knitted with the Lace Carr. and Garter Carr.

IMPORTANT: We are giving you explicit instructions here in order to make it easy for you to follow the operations of the Lace Carr. and Garter Carr. and for making the Cables over the selected needles. Cut 2 long strands of (double) Yarn to be used for knitting the

cable stitches by hand. There are 9 sts. used for the Cables and the cables are made every 6 rows of actual knitting and the rows will show on your Row Counter. To begin with, the Lace Carr. is moved 8 times, ALWAYS move the Lace Carr. (and the Garter Carr. after knitting) COMPLETELY OFF THE NEEDLE BED ONTO THE RAILS when not in use. Knit 2 rows with the Garter Carr. (Row Counter 4) Move the Lace Carr. 8x, knit 2 rows with Garter Carr. (Row Counter 6) Again move the Lace Carr. 8x and then make the first set of Cables on the left six sts. of 9 st. cable pattern. Transfer the 3 left sts over the 3 right sts. (See cable chart). With a long doubled strand of yarn, knit the 9 sts. by hand and

THEN knit 2 rows with Garter Carr. Continue in this manner, moving the Lace Carr until the ndls. are back in working position (-B-) then knit 2 rows with Garter Carr. but when Row Counter is at 12, use the Lace Carriage first, then make Cables over the 6 sts. on the RIGHT side of the 9 st. cable pattern. Cross the left 3 sts. over the right 3 sts. (See cable chart). Knit the 9 sts. by hand, then knit 2 rows with Garter Carr. REPEAT these operations every 6 rows of actual knitting as registered on the Row Counter. The number of times you move the Lace Carr. changes, so watch carefully. Alternate the Cables from left to right continuing the (continued next page)

(continued from previous page)
transfer pattern of left 3 sts. over right 3 sts. as described. Make the cable transfers AFTER moving the Lace Carr. Knit the sts. by hand and continue.

FRONT: W.Y. cast on 162 (162) sts. Knit several rows ending with 1 row Ravel Cord to the right. T 10. COUNTER -0-. Change to 2 strands Venetia. Knit 2 rows with Standard Carr. then remove Standard Carr. from machine and replace with Garter Carr. SET PATTERN: Begin with Lace Carr. and follow the instructions as given above. Knit to R 120 (130) Remove the 26 center neck sts. on W.Y. (or you can bind them off) then knit the sts. to the left of these by hand with Ravel Cord back to -A- (out of work position). Place a piece of tape over these out of work ndls. so they will remain there. Press M Key and complete the right side first. *Continue in Pat. and on neck edge, every 5 rows decrease 1 st. 16x, and every 4 rows 1 st. 9x. At the same time, mark the side edge after R 138 (150) for setting in sleeves. After R 248 (268) remove the sts. on W.Y. Bring the sts. on the left carefully back to W.P. Press M Key. Put Row Counter to 120 (130) and follow the instructions from *.

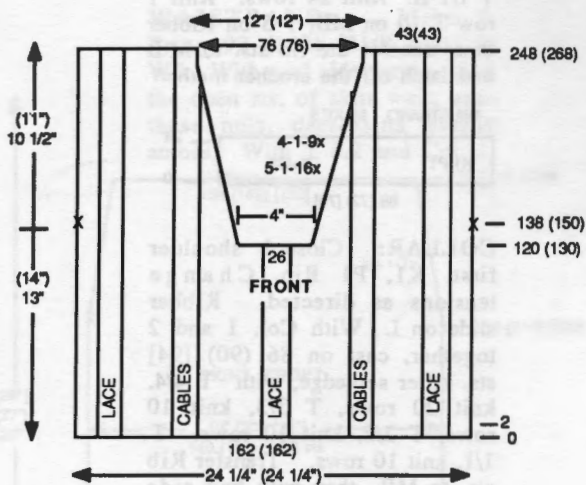

BACK: Work the back the same as front but omit the neck shaping until R 240 (260) then

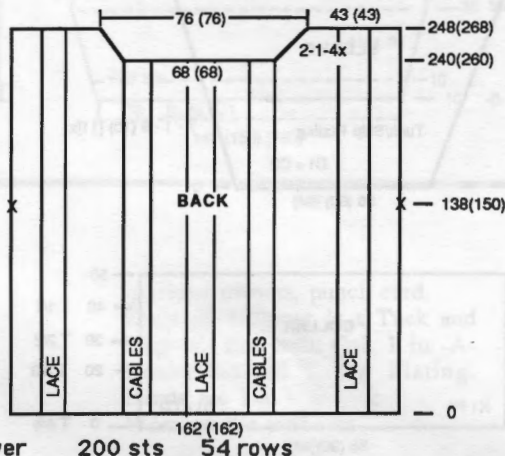

remove the center 68 (68) sts. onto W.Y. Knit the remaining sts. on the left back to -A- position with a Ravel Cord same as you did for the front. Press M Key. Complete the right side first. *ON NECK EDGE, every 2 rows decrease 1 st. 4x. After R 248 (268) remove the sts. onto W.Y. Bring the sts. on the left back to W.P. same as you did for the front. Press M Key. Counter back to 240 (260) and complete the left half following instructions from *.

SLEEVES: W.Y. cast on 148 (148) sts. Knit several rows ending with 1 row Ravel Cord to the right. T 10. Counter -0-. Change to 2 strds. Venetia and with standard Carr. knit 2 rows. Replace std. Carr. with Garter Carr. and program Pattern then continue same as for front and back and AT THE SAME TIME,

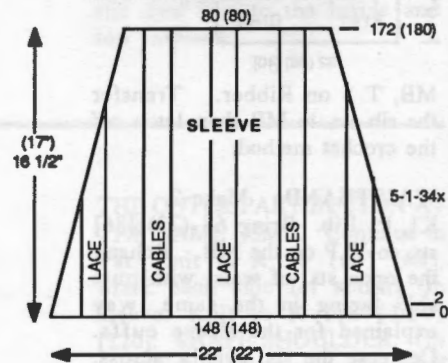

#737 - Mens Cable and Lace Pullover

200 sts 54 rows

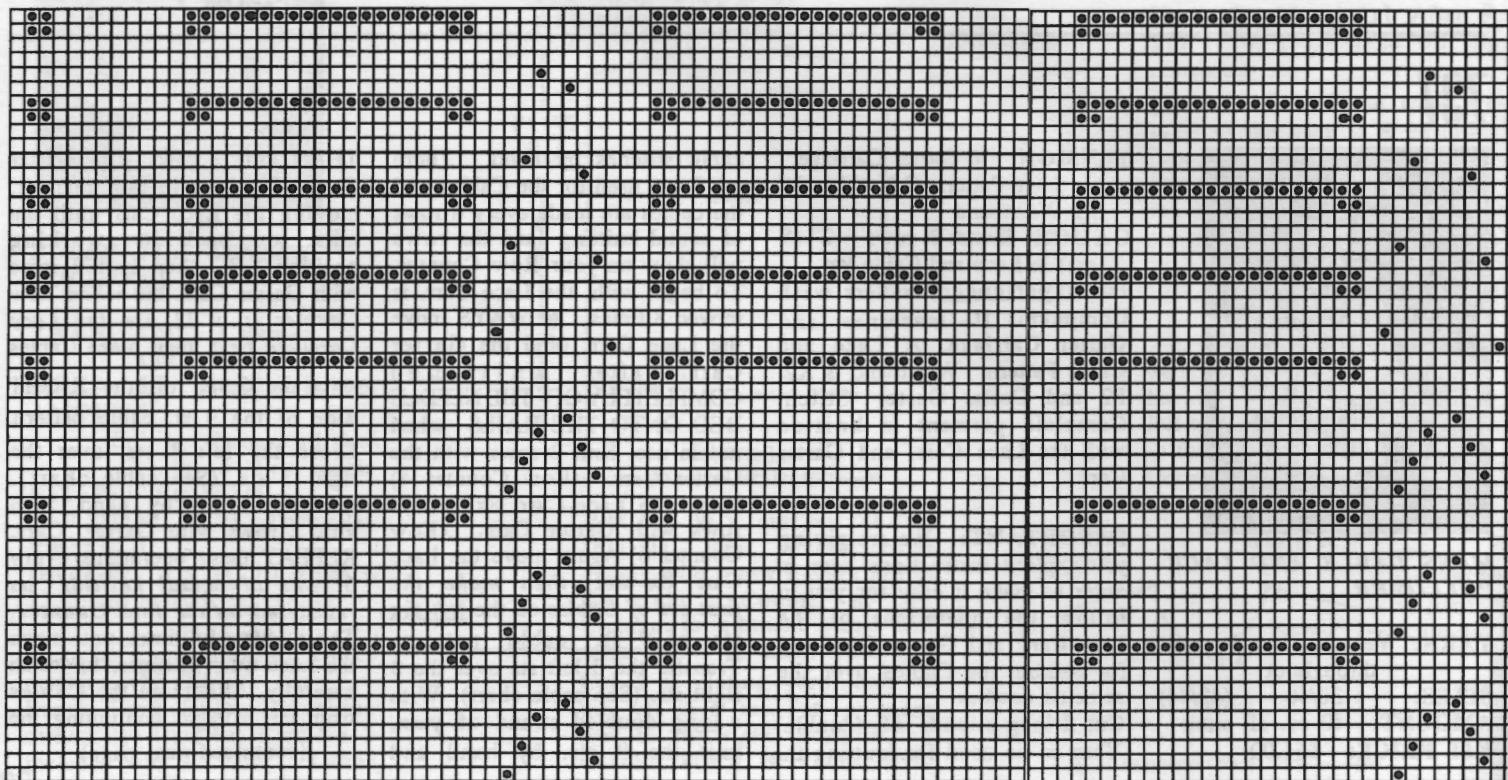

ON EACH SIDE, every 5 rows decrease 1 st. 34x. After R 172 (180) remove the sts. on W.Y

WAISTBAND: Make 2. With G.C. and Compuknit III Pattern 534. K2, P2 Rib; T 5.1. With doubled yarn, cast on 148 (152) sts. Program Pat. and knit to R 36. With purl side facing, hang the open sts. of waist onto these ndls. decreasing evenly across. Knit 1 loose row then BO the latch tool method.

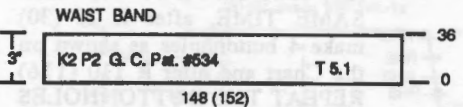

SLEEVE CUFFS: With G.C. and Compuknit III Pat. 534. K2, P2 Rib. T 5.1. With doubled yarn, cast on 68 (70) sts. Program Pat. and knit to R 36. With purl side facing pick up the open sts. sleeve and hang onto these ndls. decreasing evenly across. Knit 1 loose row then BO the latch tool method.

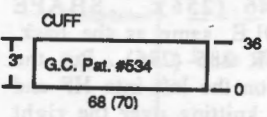

COLLAR: Compuknit III Pat. 537. Garter Stitch. T 7. With doubled strand of yarn, cast on 32 sts. Program Pattern. ON

THE LEFT, every 10 rows increase 1 st. 20 (21)x. Knit to R 240 (250). Mark each side for center of collar then continue in Pat. After R 280 (290) on the LEFT, every 10 rows decrease 1 st. 21x. After R 480 (500) BO loosely.

FINISHING: See General Instructions. Overlap left front of collar over right front then with right sides facing, pin Collar in place, with shaped edge against neckline, matching center back and easing Collar

Cable Chart
Every 6 rows of actual knitting

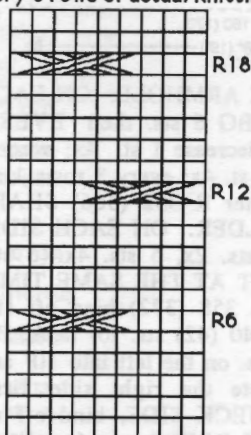

Cross the 3 sts on left in front of the 3 sts on right.

edges at front (see picture) With 1 strd. yarn, slip stitch crochet the collar in place.

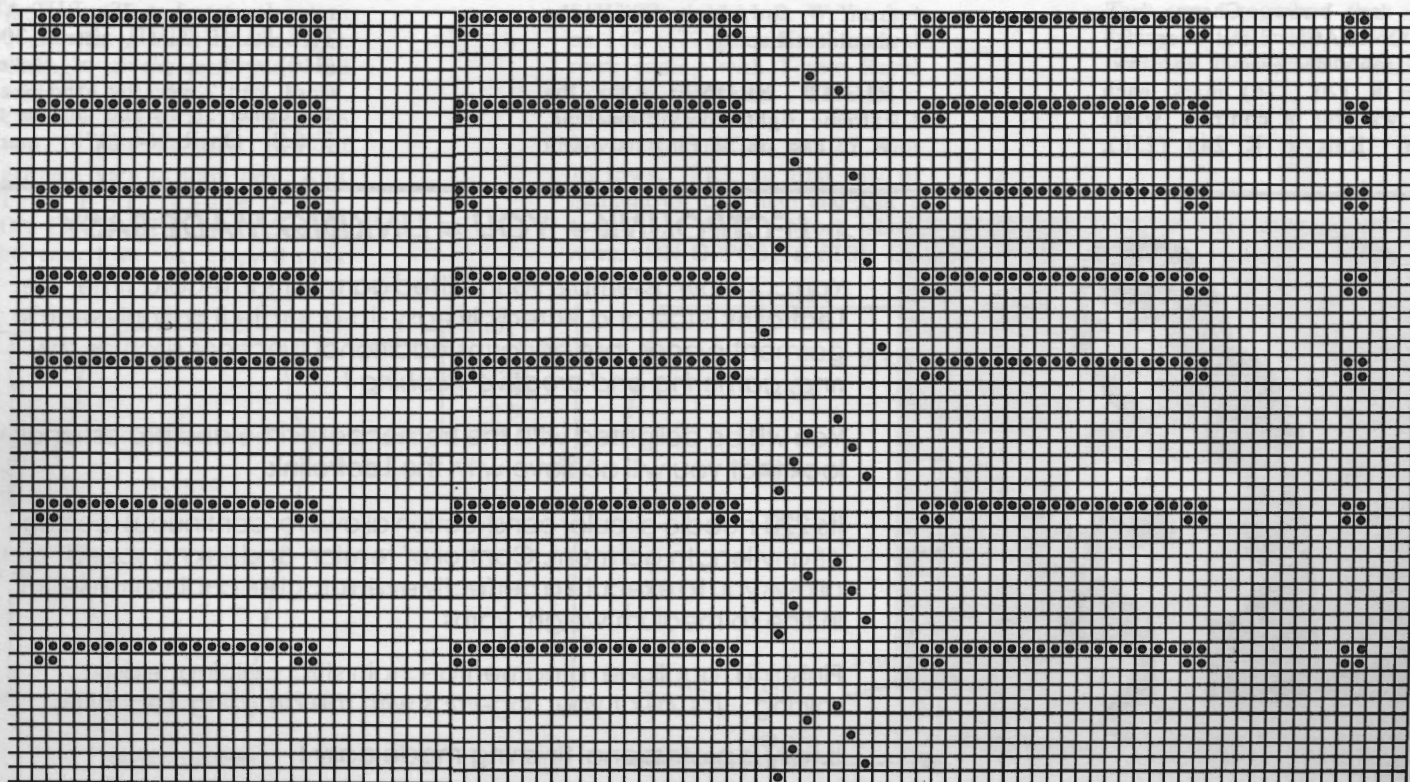
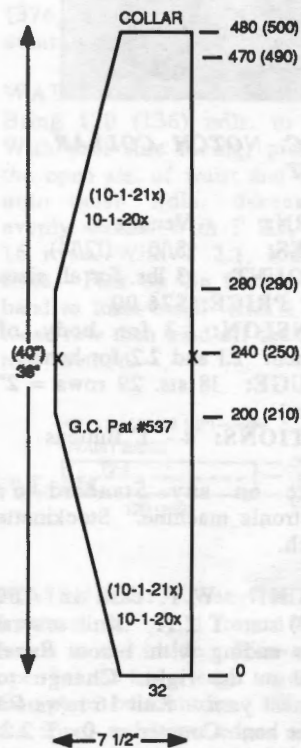



2 PC. NOTCH COLLAR SUIT

YARN: Venetia
SIZES: 8/10 (12/14)
AMOUNT: 3 lbs. for all sizes
KIT PRICE: \$76.00
TENSION: 3 for body of garment 2.1 and 2.2 for hems.
GAUGE: 18 sts. 29 rows = 2" (5 cm)
NOTIONS: 4 - 1" Buttons

Make on any Standard or Electronic machine. Stockinette stitch.

BACK: W.Y. cast on 160 (170) sts. T 2.1. Knit several rows ending with 1 row Ravel Cord to the right. Change to garment yarn. Knit 16 rows for under hem. Counter at -0-. T 2.2. Knit 16 rows. Pick up first row of garment to form hem. With T 5.1 knit 1 row. Change to T 3. ON EACH SIDE every 24 (25) rows decrease 1 st. 5x. After R 120 (126) mark each side with bit of contrast waste yarn. Knit to R 246 (256).

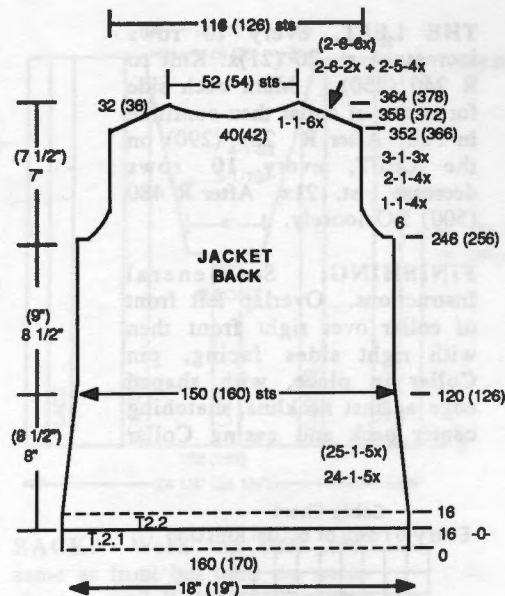

SHAPE ARMHOLE: ON EACH SIDE, BO 6 sts. then EVERY ROW decrease 1 st. 4x; every 2 rows 1 st. 4x; every 3 rows 1 st. 3x. After R 352 (366) SHAPE SHOULDER. ON EACH SIDE, BO 6 sts. 2x, 5 sts. 4x (6 sts. 6x) BUT AT THE SAME TIME, after R 358 (372) bind off the center 40 (42) sts. for neck. Put the ndls. on the left into HP and complete the right side first. *ON NECK SIDE, bind off on EVERY ROW 1 st. 6x. Bring the ndls. on the left to working position, turn Row Counter back to 358 (372) and complete the left half following instructions from * and don't forget the shoulder shaping.

RIGHT FRONT: To the extreme right side of machine, W.Y. cast on 54 (58) sts. Knit

several rows ending with 1 row Ravel Cord to the right. Change to garment yarn T 2.1. Knit 16 rows. Counter -0-. Mark st. 54 (58) T2.2. ON THE LEFT SIDE, W. Y. cast on 108 sts. Mark the center of these 108 new sts. with a bit of W.Y. With T 2.2 and garment yarn, knit 16 rows. Pick up the original 54 (58) sts. and place onto ndls. to form hem. Change to T 3 and continue in St. st. ON THE RIGHT, decrease 1 st. every 24 (25) rows 5x. BUT AT THE SAME TIME, after R 28 (30) make 4 buttonholes as shown on the Chart and after R 110 (116) REPEAT THE BUTTONHOLES over the same ndls. After R 120 (126) mark the right edge with bit of W.Y. Knit to R 229 (236) then work *short rows for bust dart*. ON OPPOSITE SIDE OF CARR. PUT INTO HOLDING POSITION every 2 rows 7 sts. 7x. Bring all the ndls. to WP and knit to the right. Put counter back to 230 (236) (the short rows do not count). Knit to R 246 (256). SHAPE ARMHOLE same as the back. Knit to R 286 (296) Put the 108 sts. on the left into HP and continue knitting over the right side sts. only to R 300 (310). Change to T 2.2. Knit to R 352 (366). Shape shoulder same as back. Bring the ndls. on the left to WP. T 3. Counter 286 (296). ON EACH SIDE, every 6 rows decrease 1 st. 18x, BUT AT THE SAME TIME, after R 300 (310) with a piece of Ravel Cord, knit 2 rows by hand over the center 36 sts and change to T 2.2. On R 364 (378) mark

LECTROLINK + YOU = LINKING MADE EASY

You can now assemble your knitted garments in record time. The **Lectrolink** is fast and incredibly easy -to-operate. It not only seams garment pieces, but performs additional functions such as *shirring, gathering and creative stitching*!

You will be delighted with the tremendous time and professional look that you will achieve with the **Lectrolink**.

Its 220-needle circular construction allows for continuous feeding of any length garment. Control of tension and linking speed allows you to execute a perfectly even crochet chain stitch seam in fine to medium weight yarns

Finishing, applique, ornamental chain stitch, piping, elastic shirring....It's all at your fingertips with the amazing **Lectrolink**.

It truly is professional finishing made easy!



each side with bit of contrast yarn then work **SHORT ROWS** on each side to shape collar: Put 5 sts. opposite Carr into HP 1x on each side then push them back to working position. **REPEAT 3 more times every 10 rows to R 408 (422).** Remove the sts. onto contrast W.Y. **WORK THE LEFT FRONT THE SAME BUT OMIT THE BUTTONHOLES**

19x (every 8 rows 1 st. 25x). After R 224 (232). **SHAPE CAP: ON EACH SIDE, BO 7 (9) sts.** then **EVERY ROW** decrease 1 st. 7x, every 2 rows 1 st. 10x, every 3 rows 1 st. 10x, every 2 rows 1 st. 10x, **EVERY ROW** 1 st. 7x. After R 312 (320) bind off the remaining sts.

CARR. bring to HP 60 sts. on each side. Bring back to working position 20 sts. every 2 rows 3x. Knit to R 100. Mark each side with bit of contrast yarn. Knit to R 200 and mark each side same as before. Knit to R 270 (276) and mark each side as before. **ON EACH SIDE,** decrease 1 st. every 10 rows 9x (10x). After R 366 (376) remove the sts. onto contrast waste yarn.

WAISTBAND: Make 2. Bring 120 (136) ndls. to WP. With purl side facing, pick up the open sts. of waist and hang onto these ndls. decreasing evenly across. With T 2.2, knit 16 rows. With T 2.1, knit 14 rows. Pick up the first row of band to form band. Knit 1 very loose row then bind off the latch tool method.

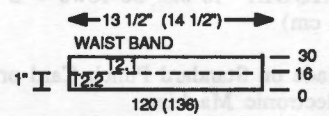
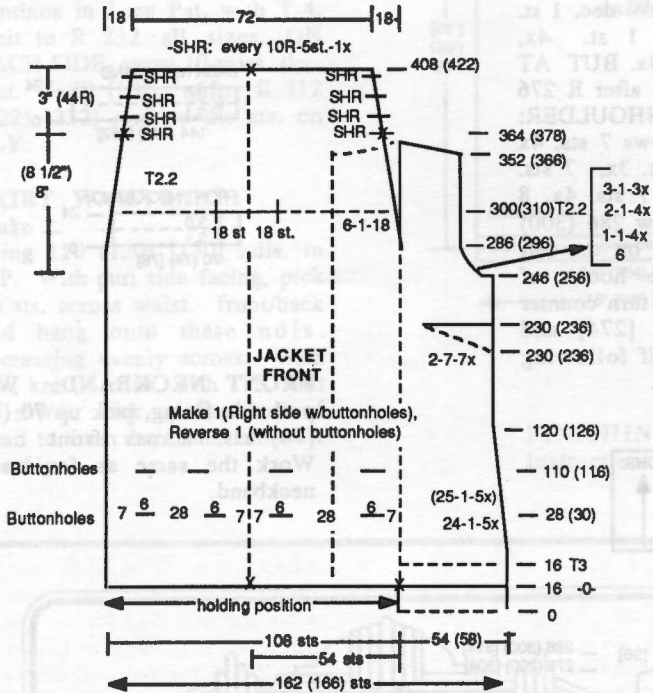

SLEEVES: W.Y. cast on 80 (86) sts. After several rows, knit 1 row Ravel Cord to the right. Change to garment yarn and with T 2.0, knit 16 rows. Counter at 0. T 2.1. Knit 16 rows. Pick up first row of garment yarn to form hem. Knit 1 row T 5.1. Change to T 3. **ON EACH SIDE,** every 7 rows increase 1 st. 6x; every 8 rows

SKIRT: Make 2. W.Y. cast on 162 (172) sts. Knit several rows ending with 1 row Ravel Cord to the right. Change to garment yarn. T 2.1. Knit 14 rows. Counter -0- T 2.2. Knit 16 rows. Pick up first row of garment to form hem and knit 1 row T 5. T 3. Work short rows. **ON OPPOSITE SIDE OF**

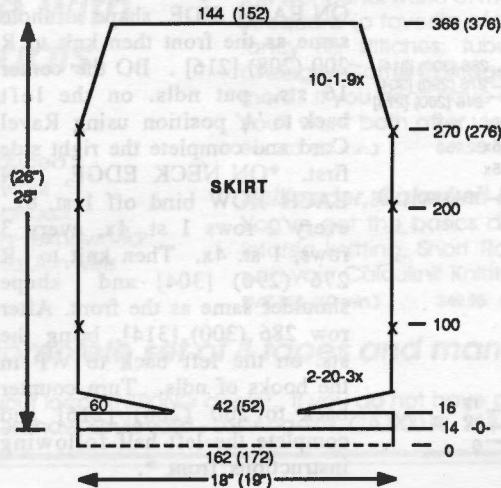
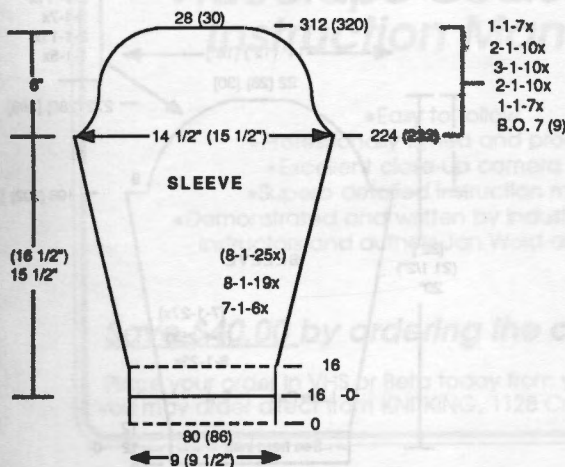

FINISHING: See General Instructions. Fold front 108 st. bands to the inside. Weave the open sts. of lower edge together. Complete buttonholes. Weave the upper and lower edges of the 18 sts. separately (this forms the lapels). Weave the back neck sts. together then fold facing to the inside. Close slit on front. Sew on buttons.



WOMEN'S TWO PIECE LACE DRESS

YARN: Venetia
SIZES: 6/8 (10/12) [14/16]
AMOUNT:
 2 cones (2 lbs.) all sizes
KIT PRICE: \$47.00
TENSION: 4 (Lace)
GAUGE: 16 sts., 26 rows = 2" (5 cm)

Made on Standard Punch Card or Electronic Machine.

IMPORTANT NOTE:
Knit all hems as follows:

- 1 Row T-4
- 9 Rows T-3
- 13 Rows T-3.1

After R 12, reset counter to -0-. Knit to R11. After R11, pick up first row to form hem. Knit 1 row T-6 then change to Tension 4, knit to right and begin LACE Pattern.

FRONT: W.Y. cast on 146 (154) [162] sts. and following the instructions above as given for hem. Set Pattern and continue in pattern T-4 to R 184

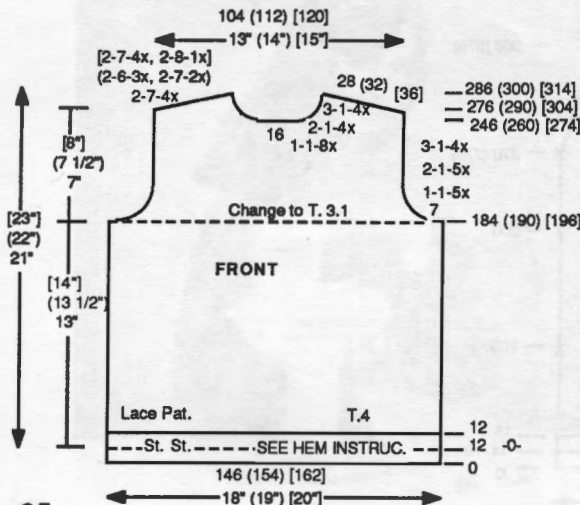

25

(190) [196]. Change to T 3.1 and continue in Pat. **SHAPE ARMHOLE: ON EACH SIDE, BO** 7 sts. then on **EVERY ROW**, dec. 1 st. 5x, every 2 rows 1 st. 5x, every 3 rows 1 st. 4x. After R 246 (260) [274] Bind off the center 16 sts. put the ndls. on the left back to 'A' position (use a Ravel Cord) and complete the right side first. Be sure to note Row number. ***ON NECK EDGE, EVERY ROW** dec. 1 st. 8x, every 2 rows 1 st. 4x, every 3 rows 1 st. 4x. **BUT AT THE SAME TIME**, after R 276 (290) [304] **SHAPE SHOULDER:** Bind off every 2 rows 7 sts. 4x (every 2 rows 6 sts. 3x, 7 sts. 2x) [every 2 rows 7 sts. 4x, 8 sts. 1x]. After row 286 (300) [314] bring the sts. on the left back to WP in the hooks of ndls. Set Pat. row, turn counter back to 246 (260) [274] and complete the left half following instructions from *.

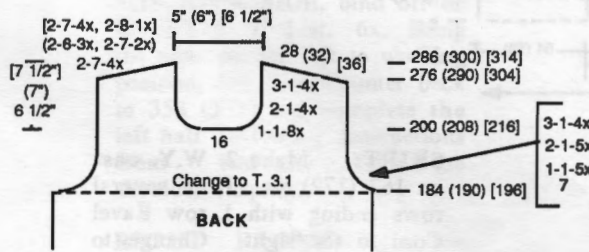
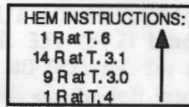

BACK: Make the back the same as the front to R 184 (190) [196]. Change to Tension 3.1. **ON EACH SIDE**, shape armhole same as the front then knit to R 200 (208) [216]. **BO** the center 16 sts., put ndls. on the left back to 'A' position using Ravel Cord and complete the right side first. ***ON NECK EDGE, ON EACH ROW** bind off 1 st. 8x., every 2 rows 1 st. 4x, every 3 rows, 1 st. 4x. Then knit to R 276 (290) [304] and shape shoulder same as the front. After row 286 (300) [314], bring the sts. on the left back to WP in the hooks of ndls. Turn counter back to 200 (208) [216] and complete the left half following instructions from *.

BACK NECKBAND:
 St. st. With purl side facing, pick up 144 (148) [152] sts. across back neck. With T 3.1, knit 12 rows. With T 3.0, knit 12 rows. Pick up first row of band and bind off loosely.

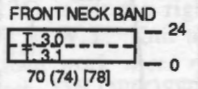
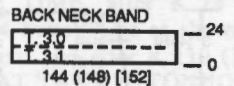

FRONT NECKBAND: With purl side facing, pick up 70 (74) [78] sts. across front neck. Work the same as for back neckband.

SLEEVES: Cast on 68 (72) [76] sts. and work the band same as for front and back hem. After hem, continue in Lace Pat with T-4. **ON EACH SIDE**, every 8 rows increase 1 st. 23x (every 7 rows 1 st. 25x) [every 7 rows 1 st. 27x]. After R 196 (202) [208] **SHAPE CAP: ON EACH**

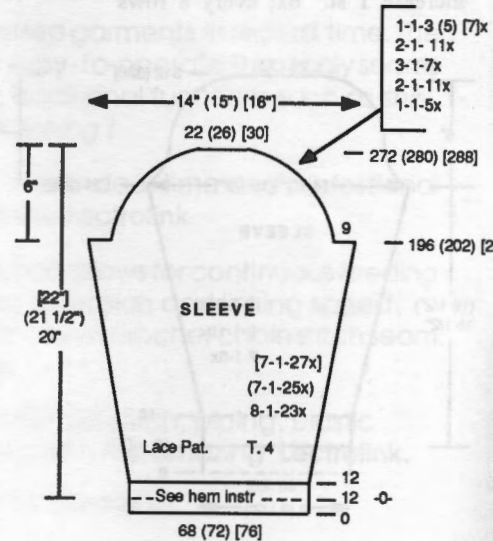

SIDE, bind off 9 sts. Then **EVERY ROW** dec. 1 st. 5x, every 2 rows 1 st. 11x, every 3 rows 1 st. 7x, every 2 rows 1 st. 11x, and **EVERY ROW** 1 st. 3 (5) [7]x. After R 272 (280) [288] bind off the remaining sts.

SKIRT: Make 2.

Cast on 146 (154) [162] sts. and work the hem same as for top back and front. After hem, continue in Lace Pat. with T-4. Knit to R 232 all sizes. **ON EACH SIDE**, every 10 rows dec. 1 st. 8 (9) [10]x. After R 312 (322) [332] remove the sts. on W.Y.

SKIRT WAISTBAND:

Make 2.

Bring 110 (120) [130] ndls. to WP. With purl side facing, pick up sts. across waist front/back and hang onto these ndls. decreasing evenly across. With T-4, knit 16 rows, with T-3, knit 16 rows. Pick up first row of band to form hem and bind off loosely.

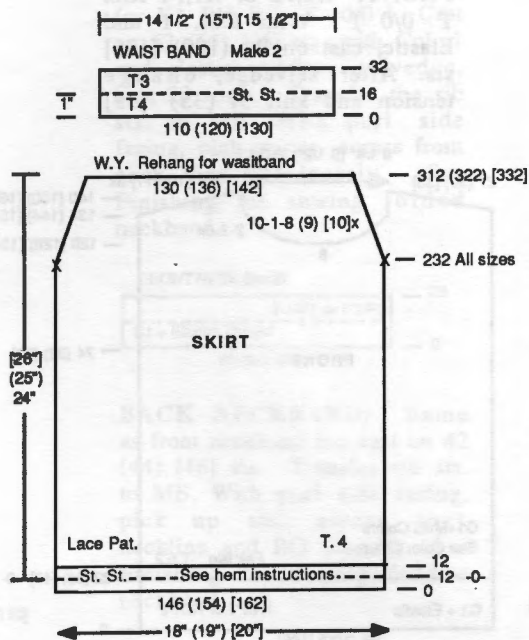

#737 - Lace Pattern

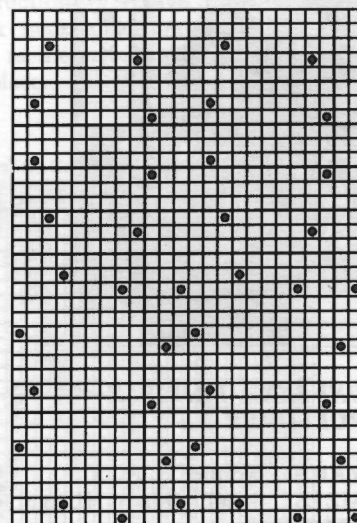

FINISHING: See General Instructions.



The First Complete Videotape Course with Instruction Manuals

- Easy to follow
- Professionally filmed and produced
- Excellent close-up camera work
- Superb detailed instruction manuals
- Demonstrated and written by industry-reknowned instructors and authors Jan Wold and Jan Mills

Basic Machine Knitting

Fundamentals of machine knitting including machine parts, multiple cast-on and bind-off techniques, shaping techniques; *includes making a complete garment.*
BVK101 (75 min.) \$54.95 (Includes manual)

Patterning Capabilities: Punch Card & Electronic

Get to know the full capabilities of texture and technique. Major patterning techniques (Fairisle, Lace, Weaving, Tuck, etc); 4-Color Changer; Disk Drive; Pattern Design Computer.
BVK102 (110 min.) \$54.95 (Includes manual)

Ribber and Garter Carriage

These major accessories open a whole new spectrum in the wonderful world of machine knitting. Learn double Jacquard (a favorite of the pricey fashion designers!); fancy rib stitches; tubular knitting; Ribber 4-Color Changer; Garter Carriage cast-on, pattern stitches and more. If you don't have a Ribber or Garter Carriage—you'll want both after viewing this tape.
BVK 103 (55 min.) \$49.95 (Includes manual)

Knitleader, Calcuknit & Advanced Techniques

You've got the basics down pat now—time to learn Intarsia knitting, Short Rows, Cords, Cables, Charting with your Calcuknit Knitting Calculator and more.
BVK 104 (60 min.) \$49.95 (Includes manual)

Save \$40.00 by ordering the complete set of 4 tapes and manuals for only \$169.95!

Place your order in VHS or Beta today from your local KNITKING dealer. If you do not have a KNITKING dealer in your area, you may order direct from KNITKING, 1128 Crenshaw Boulevard., Los Angeles, CA 90019, 213-938-2077. Visa, M/C welcome.



UNI-SEX FAIRISLE PULLOVER

YARN: Nordic
SIZES: Small (Med) [Large]
AMOUNT:

- Col. 1 Black
 16 oz 18 oz 22 oz.
 - Col. 2 Flag: 4 oz. all sizes
 - Col. 3 Mink: 5 oz. all sizes
 - Col. 4 Fuschia: 3 oz. all sizes
 - Col. 5 Gold: 2 oz. all sizes
 - Col. 6 Violet: 2 oz. all sizes
 - Col. 7 Turquoise: 1 oz. " "
 - Col. 8 Spruce: 2 oz. all sizes
- Knit in Elastic - 1 spool

KIT PRICE:
 \$45.00 \$47.50 \$52.00
TENSION: 5. Rib. T- 0/0 I
GAUGE: 9.6 Sts. 12.8 Rows =
 2" (5 cm)

Make on any Punch Card Bulky machine with Ribber.
 A Multi-color Fair Isle Design with K2/P2 or K1/P1 ribbing for bands.

FRONT: K2,P2 or K1,P1 Rib. T 0/0 I With Col. 1 and Elastic, cast on 94 (100) [106] sts. After selvedge, change tension and knit 31 (35) [39]

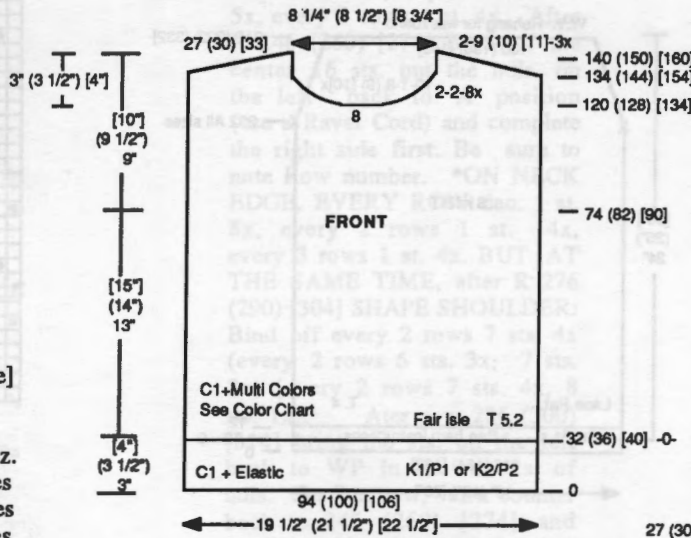

rows. Transfer rib sts. to MB. Cut off elastic. Change to T 5.2. Set Fair Isle Pat. on next Row to the the Right. COUNTER -0-. Knit in Pat. following COLOR CHART for changes in color. After R 74 (82) [90] mark each side for setting in Sleeves. Cont. in Pat. to R 120 (128) [134]. Bind off the center 8 sts. for all sizes. Put the ndls. on the left into HP and complete the right side first. Mark down Pat. Row number. *On every 2 rows ON NECK EDGE, bind off 2 sts. 8x and after R 134 (144)

[154] SHAPE SHOULDER: BO 9 (10) [11] sts. 3x. Bring the ndls. on the left into WP, SET PAT. Turn Row Counter back to 120 (128) [134] and complete the left half following instructions from *.

BACK: Work the back the same as front to R 134 (144) [154] (omit the neck shaping.)
SHAPE SHOULDER: ON EACH SIDE, BO 9 (10) [11] sts. 3x then mark center 40 sts. for back neck opening. BO (or remove on W.Y.) the remaining neck sts.

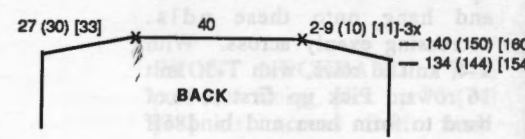

SLEEVES: With W.Y. cast on 56 (58) [60] sts. After several rows end with one Ravel Cord to the LEFT. Change to Col. 1 at T 5.2 and set Pat. on next row to the right. Continue in Fair Isle Pat. following the color changes in Feeder B as shown (continued next page)

knitking technical tips

On occasion, the Disk Drive will not "boot" a given pre-formatted diskette ("boot" refers to the Disk Drive's ability to get the information stored on the diskette; a pre-formatted diskette is one with patterns already on it).

When this occurs, you should use the following routine:

- 1) Open the diskette door by pushing the Eject button.
- 2) Remove the diskette.
- 3) Close the diskette door by pushing down on the Disk In/Out Bar.
- 4) Turn the On/Off Switch first On, then Off, then On again.
- 5) Open the disk door by again pushing the Eject button.
- 6) Insert your diskette, and close the disk door.

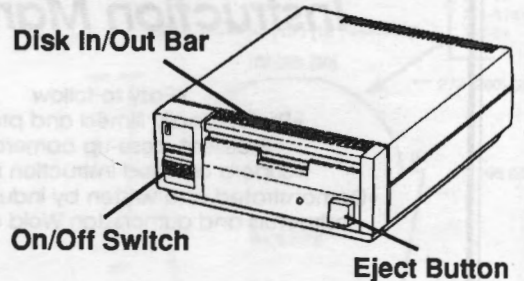

If you still are experiencing problems "booting" the diskette, repeat this procedure. Repeat again, if necessary.

As a matter of good practice, you should always initiate any use of this Disk Drive by following the above routine—it serves to prepare the Disk Drive for the incoming diskette by aligning the drive mechanism properly.

(continued from previous page)
 on color chart. ON EACH SIDE,
 every 7 rows increase 1 st. 10x
 for all sizes, then every 8 rows
 1 st. 3(4)[5]x. After R 94 (102)
 [110] bind off or remove the sts.
 on W.Y.

SLEEVE CUFF: K1 P1 Rib.
 With Col. 1 and knit-in Elastic
 Thread at T. 0/0 I, cast on 42
 (44) [46] sts. After selvedge,
 knit 24 rows. Transfer Rib sts.
 to MB. Cut elastic. With
 wrong side facing, pick up the
 open sts. of sleeve and hang
 onto these ndls. decreasing
 evenly across. Knit 1 very
 loose row, then BO.

FRONT NECKBAND: K2 P2
 (or K1 P1) Rib. T- 0/0 I Cast
 on 62 (64) [66] sts. with Col. 1
 and elastic. After selvedge,
 knit 28 rows. Transfer the rib
 sts. to MB. With purl side
 facing, pick up sts. across front
 neck then BO loosely. See
 Finishing for sewing folded
 neckband.

FINISHING: See General
 Instructions. Weave front and
 back neckbands together then
 fold to the wrong side and sew
 in place.

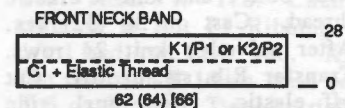
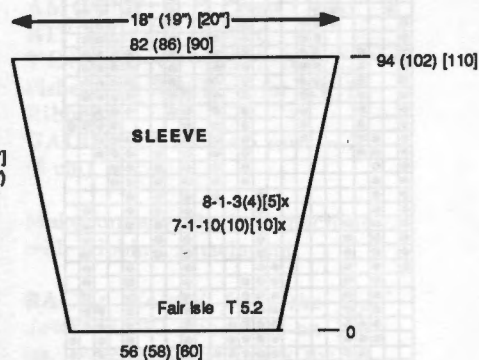

BACK NECKBAND: Same
 as front neckband but cast on 42
 (44) [46] sts. Transfer rib sts.
 to MB. With purl side facing,
 pick up sts. across back
 neckline and BO loosely. See
 Finishing for sewing folded
 neckband.

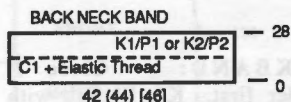

COLOR CHART FOR FAIR ISLE PATTERN

Black as Main Color, Follow Rows and Colors Below:

- | | | | |
|------|--------|-----------|---------------------|
| 10 R | Col. 2 | Flag | Starting at Row -0- |
| 6 R | Col. 3 | Mink | |
| 4 R | Col. 4 | Fuschia | |
| 8 R | Col. 5 | Gold | |
| 10 R | Col. 6 | Violet | |
| 2 R | Col. 7 | Turquoise | |
| 6 R | Col. 3 | Mink | |
| 8 R | Col. 8 | Spruce | |
| 6 R | Col. 4 | Fuschia | |

REPEAT UNTIL DONE

Pattern Card for #740 & 741

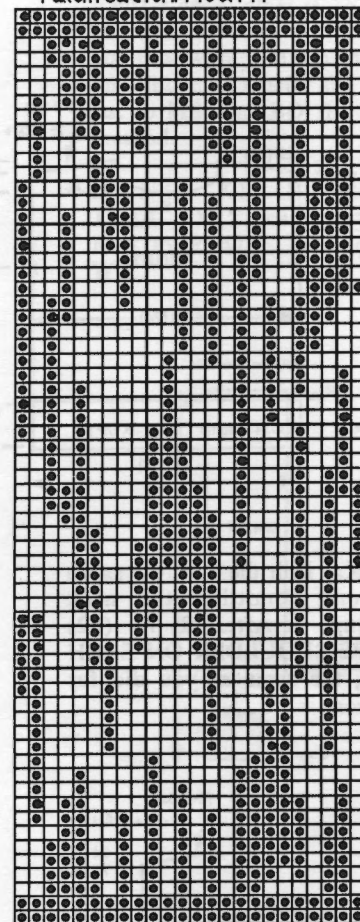

741

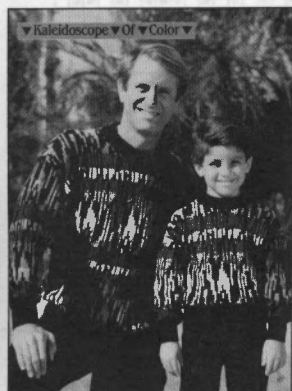

**BOYS FAIR ISLE
 SWEATER**

YARN: Nordic
SIZES: 5/6 (7/8)

AMOUNT:

- Col. 1 Black 8 oz. All sizes
- Col 2 Flag 1 oz. All sizes
- Col 3 Mink 1 oz. All sizes
- Col 4 Fuschia 1 oz. All sizes
- Col. 5 Gold 1 oz. All sizes
- Col. 6 Violet 1 oz. All sizes
- Col. 7 Turquoise 1 oz. All sizes

Col. 8 Spruce 1 oz. All sizes
 1 SPOOL KNIT-IN ELASTIC

KIT PRICE: \$20.00

TENSION: 5.2 Fair Isle; Rib
 T 0/0 I with knit in elastic.

GAUGE: 9. 6 sts. 12.8 Rows
 = 2" (5 cm)

Make on any Punch Card Bulky
 machine with Ribber.

FRONT: K1, P1 Rib. T-0/0 I
 With Col. 1 and knit in elastic,

cast on 68 (72) sts. After
 Selvedge, knit 27 rows.
 Transfer Rib sts. to MB. Cut
 elastic and increase 1 st. on
 each side. Change to garment
 tension, and set Pattern (KC)
 on next row to the right. (Row 28).
 Set for Fair Isle Pattern and
 changing colors in Feeder B as
 shown on the Color Chart.
COUNTER -0-. Knit to R 38
 (40). Mark each side with bit
 of contrast yarn for setting in
 sleeves. Knit to R 68 (72).
 Bind off the center 6 sts., put
 the ndls. on the left into HP and
 complete the right side first.
 Make note of Row Number on
 pattern. *ON NECK SIDE, every
 2 rows BO 2 sts. 5x, and after
 (continued next page)

(continued from previous page)
 R 78 (82), SHAPE SHOULDER:
 Every 2 rows BO 7 sts. 2x, 8
 sts. 1x (every 2 rows BO 8 sts.
 3x). Bring the ndls. on the left
 back to WP, turn Row Counter
 back to 68 (72) Set correct
 pattern row and complete the left
 half following instructions from
 *.

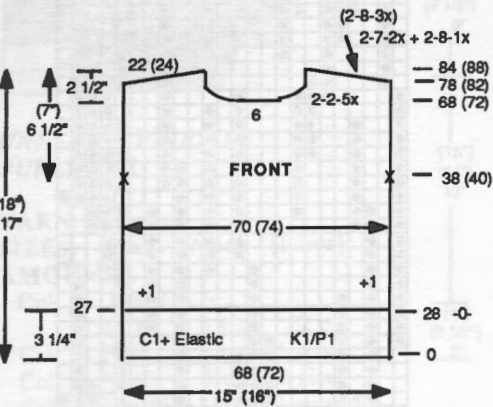

BACK: Knit the back the same
 as front omitting the neck
 shaping. After R 78 (82)
 SHAPE SHOULDER ON EACH
 SIDE, the same as you did for
 the front.

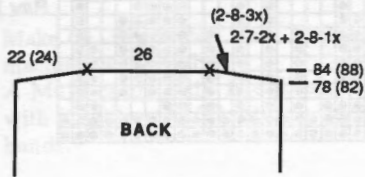

SLEEVES: W.Y. cast on 44
 (48) sts. After several rows,
 end with 1 row Ravel Cord to
 the LEFT. Change to Col. 1 and
 Set Pat. on next row to the
 right. Counter -0-. Continue in
 Fair Isle Pattern same as before

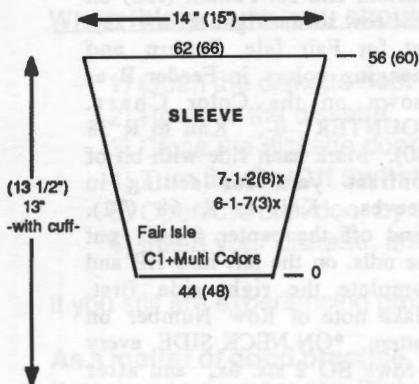

following *Color changes in
 Feeder B as shown on the Color
 Chart.* ON EACH SIDE, every 6
 rows increase 1 st. 7x (3x),
 every 7 rows 1 st. 2x (6x).
 After R 56 (60), knit 1 very
 loose row then BO the latch tool
 method.

SLEEVE CUFFS: K1, P1 Rib
 with Col. 1 and knit-in elastic
 thread. Cast on 30 (32) sts.
 After selvedge knit 24 rows.
 Transfer Rib. sts. to MB. Cut
 off elastic. With purl side
 facing, pick up the open sts. of
 sleeve and hang onto these ndls.
 decreasing evenly across. Knit
 1 very loose row then BO the
 latch tool method.

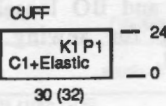

NECKBAND: Close 1
 shoulder first. K1, P1 Rib with
 Col. 1 and elastic thread. Cast
 on 76 (80) sts. Knit 28 rows.
 Transfer rib sts. to MB. Cut off
 elastic. With purl side facing,
 pick up 42 (44) sts. across front
 neckline, and 34 (36) across the
 back. BO loosely.

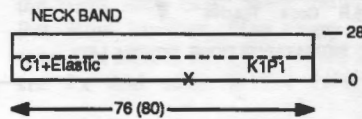

FINISHING: See General
 Instructions. Close neckband at
 shoulder then fold neckband
 over to the inside and sew in place.

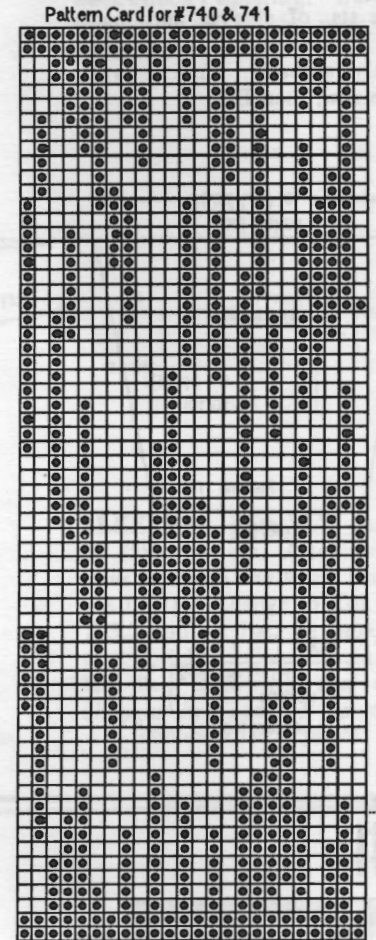

COLOR CHART FOR FAIR ISLE PATTERN
 Black as Main Color, Follow Rows and Colors Below:

10 R	Col. 2	Flag	Starting at Row -0-
6 R	Col. 3	Mink	↓
4 R	Col. 4	Fuschia	
8 R	Col. 5	Gold	↓
10 R	Col. 6	Violet	
2 R	Col. 7	Turquoise	↓
6 R	Col. 3	Mink	
8 R	Col. 8	Spruce	↓
6 R	Col. 4	Fuschia	

REPEAT UNTIL DONE



CUT-A-WAY RIBBED JACKET

YARN: Caprinae
SIZES: One size fits all.
AMOUNT: 2 Cones (28 oz.)
KIT PRICE: \$54.50
TENSION: 3/3 I for Half Fishermans Rib; 1/1 I for K1, P1 Ribbing
GAUGE: 8 sts. 14.5 rows = 2" (5 cm)

Make on any Bulky machine with Ribbing Attachment.

BACK: Knitted from the top down. K1/P1 Rib. Cast on 101 sts. After selvedge, mark the 30 sts. on each side for shoulder. Change to T 1/1 I and knit 2 rows. Change settings to Half Fishermans Rib (See Ribber manual for proper settings). T3/3 I and continue in half Fishermans Rib. Knit to R 90. Mark each side for setting in sleeve. Knit to R 178. Change to K1, P1 ribbing (all controls normal) T 1/1 I. Knit to R 180. Knit last row at T 10 on main bed, T 5 on Ribber. Transfer ribber sts. to MB then bind off the latch tool method.

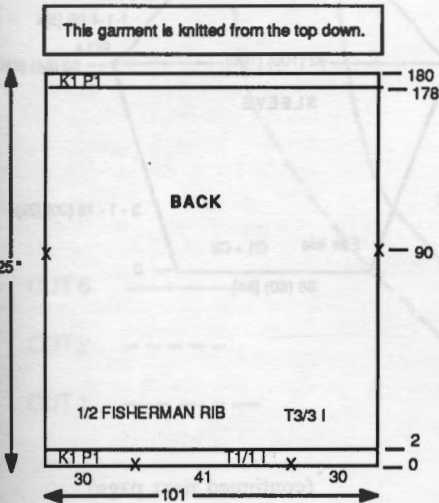

FRONT: Knitted from the neck down. Make 1, reverse 1. K1, P1 Rib. Cast on 41 sts. After selvedge, change to T 1/1 I and knit 2 rows. Change settings to half Fishermans Rib. T-3/3 I. After R 90, mark right/left edge for setting in sleeves. After R 138 every 2 rows decrease 1 st. 20x. After R 178. Change controls to K1, P1 Ribbing. T 1/1 I and knit to R 180. Knit last row with T 10 on main bed, T 5 on Ribber. Transfer ribber sts. to MB then bind off the crochet method.

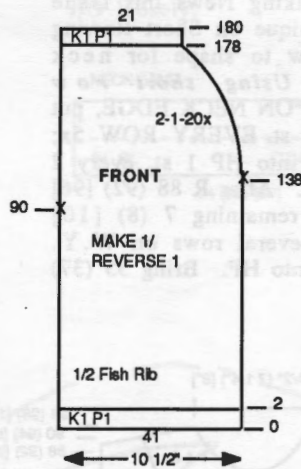

SLEEVES: K1, P1 Rib. cast on 100 sts. After selvedge, change to T 1/1 I and knit 2 rows. Change setting to half Fishermans Rib. T 3/3 I and continue in Half Fishermans Rib. ON EACH SIDE, every 7 rows decrease 1 st. 10x. After R 90, remove on to W.Y.

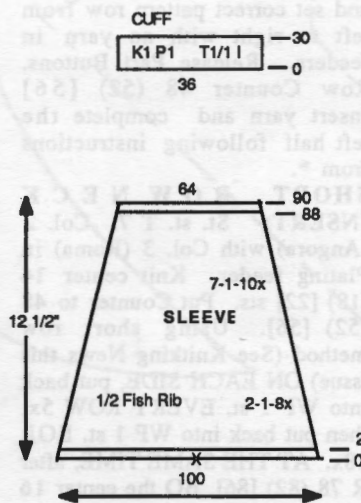

SLEEVE CUFFS: K1, P1 Ribbing. T-1/1 I. Bring 36 ndls. to WP and with wrong side facing, pick up sts. and hang onto these ndls. decreasing evenly across. Knit 1 row then transfer every other st. to Ribber and knit 30 rows K1, P1. Knit last row with T 10 on MB, T-5 on Ribber. Transfer the Ribber sts. to MB and BO the crochet method.

BAND: K1, P1 Ribbing. T1/1/I. W.Y. cast on 31 sts. Knit to R 470. Remove on W.Y.

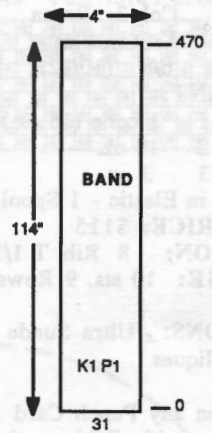

FINISHING: Close shoulders easing the 41 sts. of front shoulder to the back 30 sts. for shoulder. Seam sides and sleeves. Pin the band all around edges of Jacket and weave the open sts. at center back. Sew band in place.



WOMENS ANGORA and PEBBLE PULLOVER

YARN: Col. 1: Pebble
Col. 2: Angora/Wool
Col. 3: Roma
Knit-in Elastic

SIZES: 6/8 (10/12) [14]

AMOUNT:

Col. 1 1 cone (16 oz.)

Col. 2 10 oz.

Col. 3 3 oz.

Knit in Elastic - 1 Spool

KIT PRICE: \$115

TENSION: 8 Rib. T 1/1 I

GAUGE: 10 sts. 9 Rows = 2" (5 cm)

NOTIONS: Ultra Suede Trim for appliques

Make on any Punch Card Bulky machine with Ribber in Fair Isle Pattern. Use every second needle Punch Card (a standard card that comes with your machine). Bands are K1, P1 ribbing.

BACK: W.Y. cast on 92 (100) [108] sts. Knit several rows ending with 1 row Ravel Cord to the LEFT. Change to Col. 1 and set Pattern to the RIGHT. Counter at -0-. Insert Col. 2 in

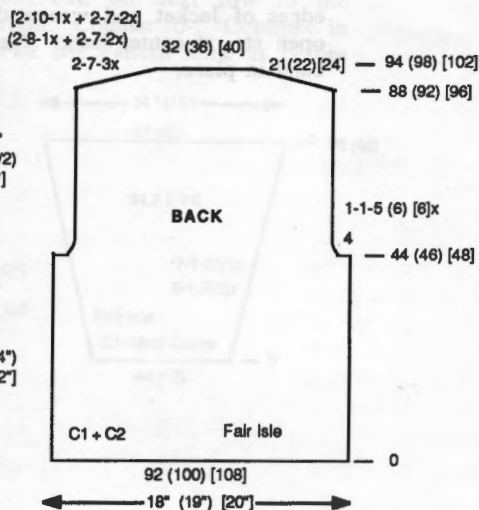

B Feeder and continue in Fair Isle Pattern. Knit to R 44 (46) [48]. **SHAPE ARMHOLE:** ON EACH SIDE, BO 4 sts. then decrease 1 st. EVERY ROW 5 (6) [6]x. After R 88 (92) [96] **SHAPE SHOULDER:** ON EACH SIDE, BO (or use short row method) 7 (8) 10) sts. 1x, 7 sts. 2x for all sizes. After R 94 (98) [102] remove the remaining neck sts. on W.Y.

FRONT: Work the same as the back to R 48 (52) [56]. Put 49 (55) [61] ndls. on the left to holding position and complete the right side first. Mark down row number on pattern card. (See Knitkng News this issue for Technique on Short Rowing every row to shape for neck insert) *Using short row method:* *ON NECK EDGE, put into HP 1 st. EVERY ROW 5x; then put into HP 1 st. every 2 rows 18x. After R 88 (92) [96] knit the remaining 7 (8) [10] sts. on several rows on W.Y. and put into HP. Bring 35 (37)

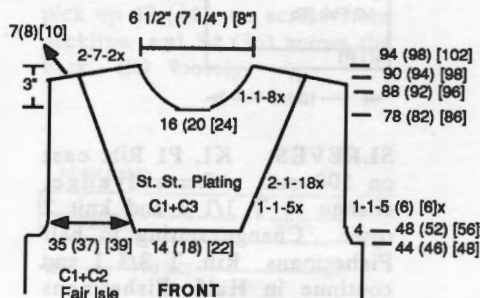

[39] ndls. on the left to WP and be sure the sts. are in the hooks of ndls. Push in Part buttons and set correct pattern row from left to right with no yarn in feeders. Release Part Buttons. Row Counter 48 (52) [56] Insert yarn and complete the left half following instructions from *.

SHORT ROW NECK INSERT: St. st. T 7. Col. 2 (Angora) with Col. 3 (Roma) in Plating feeder. Knit center 14 (18) [22] sts. Put Counter to 48 (52) [56]. Using short row method (See Knitkng News this issue) ON EACH SIDE, put back into WP 1 st. EVERY ROW 5x, then put back into WP 1 st. EOR 18x. AT THE SAME TIME, after R 78 (82) [86], BO the center 16

(20) [24] sts. put the ndls. on the left to HP and complete the right side first. *ON NECK SIDE, EVERY ROW decrease 1 st. 8x and after R 90 (94) [98] **SHAPE SHOULDER:** Short row every other row 7 sts. 2x all sizes. Bring the ndls. on the left to WP. Row Counter 78 (82) [86] and complete the left half following instructions from *.

SLEEVES: W.Y. cast on 56 (60) [64] sts. After several rows end with 1 row Ravel Cord to the LEFT. Set Pattern on next row same as you did for back. Counter -0-. Continue in Fair Isle Pat. ON EACH SIDE, every 3 rows increase 1 st. 18 (20) [22] x. After R 60 (64) [68], **SHAPE CAP:** on each side, BO 4 st. then EVERY ROW BO 1 st. 4 (6) [8] x then every 2 rows BO 4 sts. 7x. After R 80 (86) [92] BO the remaining sts.

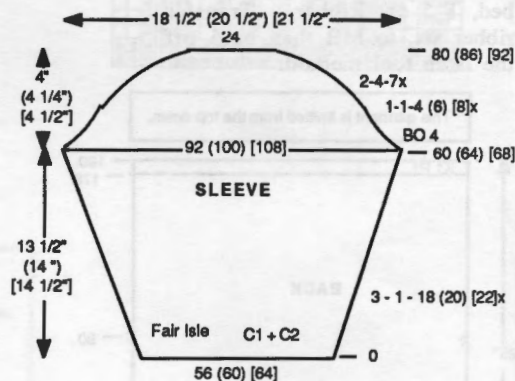
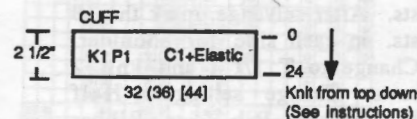

(continued next page)

SLEEVE CUFF: K1, P1 Rib. T 1/1 I. Bring 32 (36) [44] ndls. to W.P. With purl side facing, hang the open sts. of sleeve onto these ndls. decreasing evenly across. Knit 1 row Col. 1 and knit-in elastic, then transfer every other st. to Ribber. Knit 18 rows. Knit 1 row with T 10 on MB, T 5 on Ribber. Transfer the ribber sts. to MB and BO the latch tool method.

WAISTBAND: K1, P1 Rib. T 1/1 I. Make 2. Bring 82 (86) [90] ndls. to WP. With purl side facing, hang the open sts. of waist onto these ndls. decreasing evenly across. Knit 1 row Col. 1 and knit-in elastic, then transfer every 2nd st. to Ribber. Knit 24 rows. Knit 1 row with T 10 on MB, T 5 on Ribber. Transfer the rib sts. to MB and BO the latch tool method.

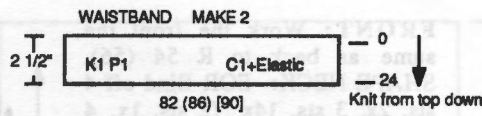

NECKBAND: For neckband use Col. 2 and Col. 3 for plating. Close 1 shoulder first. Bring 74 (80) [86] ndls. to WP. With purl side facing, pick up 32 (36) [40] sts across back neck, and pick up 42 (44) [46] sts across front neck. Work St. st. with plating. Knit 8 rows at T 6, 2 rows at T 4. Insert elastic with plating and with T 6, knit 10 rows. Pick up first row of band to form hem then BO loosely.

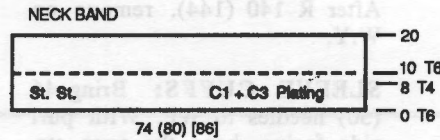

FINISHING: See General Instructions. Cut out Ultra Suede design backing it with Wonder Under or Tuff Fuse press on backing. Using a small zig-zag st. on sewing machine, sew all around design.

#743 - Fair Isle Pattern Card

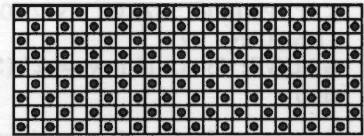

APPLIQUE PATTERN FOR TRIM

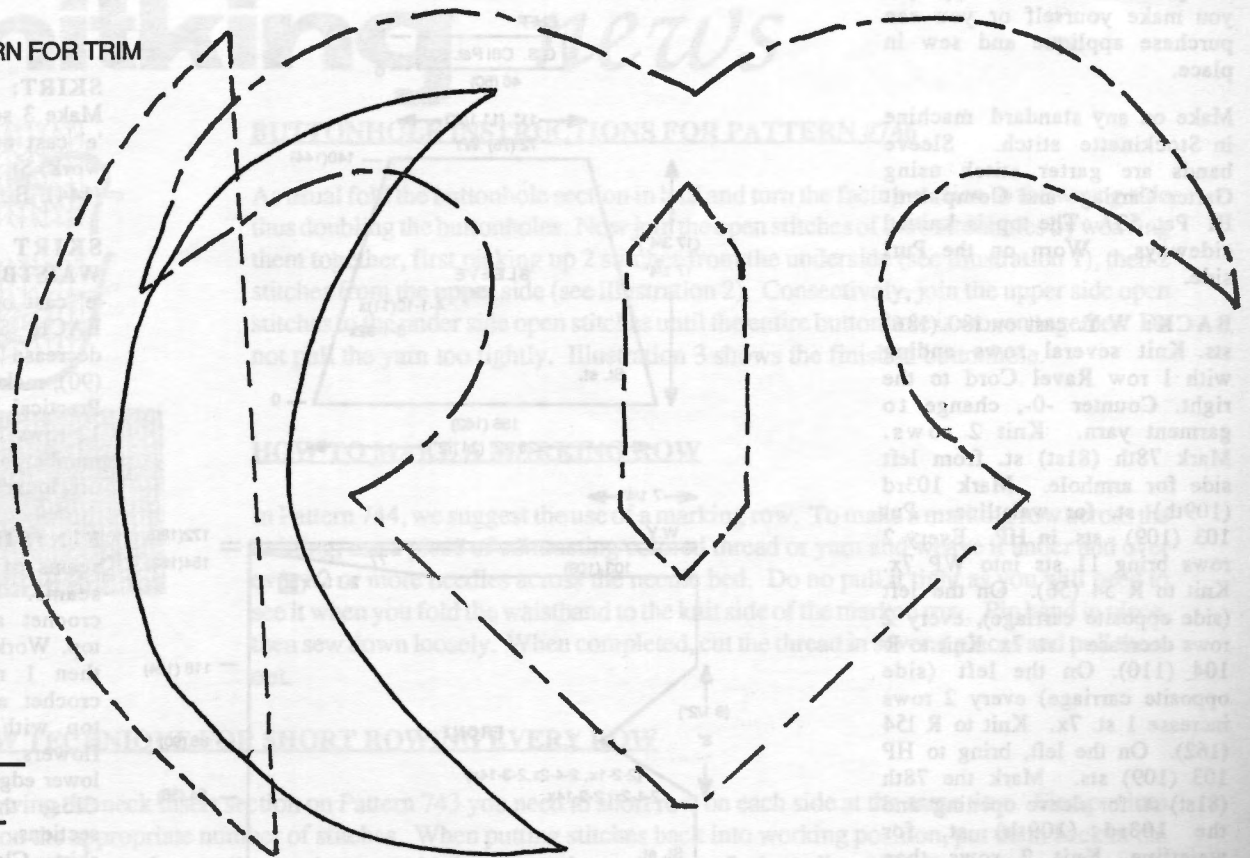

- CUT 6 —————
- CUT 2 - - - - -
- CUT 1 - · - · -



2 PC. PUFF SKIRT DRESS

YARN: Ice Cream
SIZES: 4/6 8/10
AMOUNT: 4l oz. 43 oz.
KIT PRICE: \$70.00 \$72.00
TENSION: 9
GAUGE: 13 st. 16 rows = 2" (5 cm.)

Fabric and Ribbon for applique design on front of top and netting to form puff on skirt are not included in Kit. Use 2 1/2" wide and 1 1/2" wide ribbon. Purchase 1/2 yd netting for skirt. See picture for ribbon applique you make yourself or you can purchase applique and sew in place.

Make on any standard machine in Stockinette stitch. Sleeve bands are garter stitch using Garter Carriage and Compuknit III Pat. 537. The top is knitted sideways. Worn on the Purl side.

BACK: W.Y. cast on 180 (186) sts. Knit several rows ending with 1 row Ravel Cord to the right. Counter -0-, change to garment yarn. Knit 2 rows. Mark 78th (81st) st. from left side for armhole. Mark 103rd (109th) st. for waistline. Put 103 (109) sts. in HP. Every 2 rows bring 11 sts into WP 7x. Knit to R 54 (56). On the left (side opposite carriage), every 2 rows decrease 1 st. 7x. Knit to R 104 (110). On the left (side opposite carriage) every 2 rows increase 1 st. 7x. Knit to R 154 (162). On the left, bring to HP 103 (109) sts. Mark the 78th (81st) st. for sleeve opening and the 103rd (109th) st. for waistline. Knit 2 rows then every 2 rows bring to HP 11 sts. 7x. After R172 (180), bring all needles to W.P. and remove on W.Y.

FRONT: Work the front the same as back to R 54 (56). **SHAPE NECK:** EOR Bind off 4 sts. 2x, 3 sts. 14x (2 sts. 1x, 4 sts. 2x, 3 sts. 14x). After R 86 (90), EOR cast on 3 sts. 14x, 4 sts. 2x (3 sts. 14x, 4 sts. 2x, 2 sts. 1x). Continue knitting the same as the back and be sure to mark for sleeve opening and waist. Remove on W.Y.

SLEEVES: Close both shoulders first. With Purl side facing, pick up the sts. for sleeve from marked st. to marked st. **DO NOT REMOVE WASTE KNITTING** at this time. 156 (162) sts. **ON EACH SIDE**, every 3 rows decrease 1 st. 32x; then every 4 rows 1 st. 10 (11)x. After R 140 (144). remove on W.Y.

SLEEVE CUFFS: Bring 46 (50) needles to WP. With purl side facing, hang the open sts. of sleeve onto these ndls. decreasing evenly across. Set Garter Carriage and Compuknit III Pat. No. 537 (G.S.) and knit 12 rows. B.O.

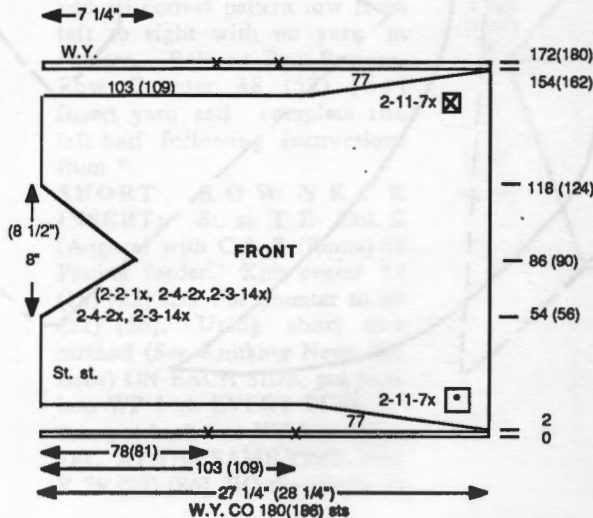
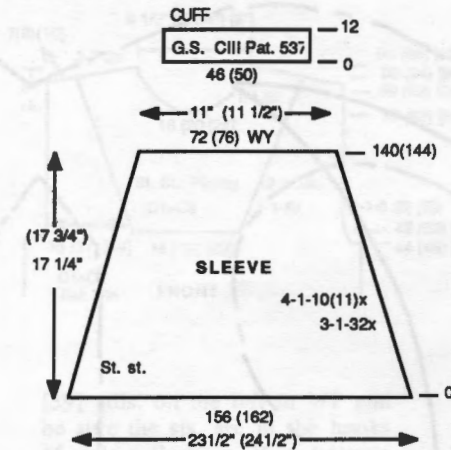
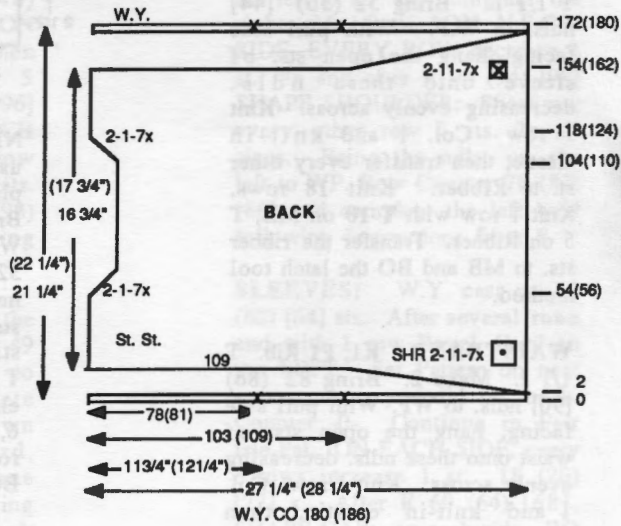

SKIRT:
 Make 3 sections the same. 'e' cast on 194 (200) sts. and work St. st. Knit to R 140 (144). Bind off.

SKIRT YOKE AND WAISTBAND: Make 2. 'e' cast on 120 (126) sts. **ON EACH SIDE**, every 10 rows decrease 1 st. 8x. After R 86 (90), make a marking row. (See Practical Hints this issue). Knit 12 rows. Turn tension down 1 number and knit 12 rows. Bind off loosely.

FINISHING: Weave side seams of top then sew sleeve seams. Work 1 row single crochet around lower edge of top. Work 1 row single crochet, then 1 row reverse single crochet around neckline. Trim top with appliques of ribbon flowers. Sew ribbon around lower edge (see picture). **SKIRT:** Close the seams of 3 skirt sections. Gather the top edge of skirt. Close side seams of skirt yoke then adjust gathers of skirt to fit. Pin carefully then on the right (purl) side, slip st. crochet the gathered skirt and yoke

together. Fold waistband to the knit side and sew loosely to marked row. Insert elastic in casing. To make pouf in skirt, you will need approx. 1 yd 72" netting. Sew the 72" width together then fold in half. Gather and sew 1 edge to inside edge of lower section of yoke. Allow the netting to drape down and fold up 5 inches of the lower edge of skirt (the netting inside the fold makes the pouf needed. Sew the 5 inches of skirt to the netting.

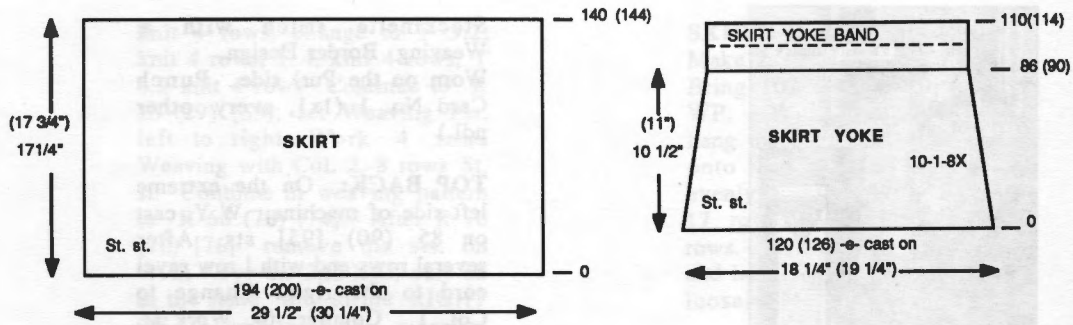

knitking news

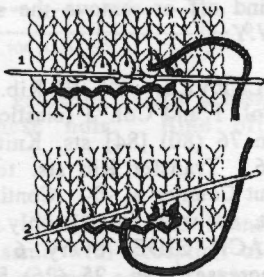

BUTTONHOLE INSTRUCTIONS FOR PATTERN #746

As usual fold the buttonhole section in half and turn the facing section to the wrong side thus doubling the buttonholes. Now join the open stitches of the buttonholes by weaving them together, first picking up 2 stitches from the underside (see illustration 1), then 2 stitches from the upper side (see illustration 2). Consectively, join the upper side open stitches to the under side open stitches until the entire buttonhole is woven together. Do not pull the yarn too tightly. Illustration 3 shows the finished buttonhole.

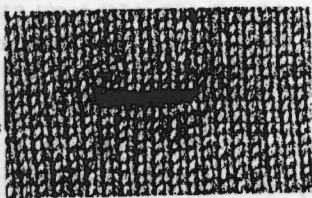

HOW TO MAKE A MARKING ROW

In Pattern 744, we suggest the use of a marking row. To make a marking row across the knitting, use a piece of contrasting colored thread or yarn and weave it under and over every 2 or more needles across the needle bed. Do no pull it tight as you will need to see it when you fold the waistband to the knit side of the marked row. Pin band in place, then sew down loosely. When completed, cut the thread in several places and pull them out.

SHORT ROW TECHNIQUE FOR SHORT ROWING EVERY ROW

When short rowing the neck insert section on Pattern 743 you need to short row on each side at the same time. First put into holding position the appropriate number of stitches. When putting stitches back into working position, put them back in the regular manner. However, for needles on the same side as the carriage, wrap the 2nd needle and push the 1st needles back to working position.



WOMENS 2 PC. DRESS

YARN:

- Col. 1: Pearlyte- Charcoal
- Col. 2: Pebble - Grey/Creme
- Col. 3: Knit-in Elastic
- Col. 4: Sewing thread

SIZES: 6/8 (10/12) [14/16]

AMOUNT:

- Col. 1 21 oz. 23 oz. 25 oz.
- Col. 2 2 oz. 2 oz. 2 oz.
- Col. 3 1 Spool-all sizes
- Col. 4 1 (1200 yd) Spool

KIT PRICE:

\$30.00 \$32.50 \$35.00

TENSION: St. st. 5, K1, P1

Rib. 0.1/0.1 FNR: 3.1/3.1

GAUGE: 14.28 sts. 23.64

Rows = 2" (5 cm).

Stockinette stitch with a Weaving Border Design. Worn on the Purl side. Punch Card No. 1 (1x1, every other nrl.)

TOP BACK: On the extreme left side of machine, W.Y. cast on 85 (90) [95] sts. After several rows end with 1 row ravel cord to the right. Change to Col. 1. Counter -0-. Work st. st. Knit 10 rows. **ON THE RIGHT SIDE,** every 2 rows increase 1 st. 5x. After R 20, cast on 50 (55) [60] sts. After R 29, set Weaving Pat from left to right then knit 3 rows Weaving, 4 rows St. st. and REPEAT 6 times more BUT AT THE SAME TIME, Shape shoulder: every 10 rows increase 1 st., 5x. Continue in St. st. After R 72 mark with a bit of extra yarn. **ON NECK EDGE,** every 2 rows decrease 1 st., 5x. After R 122 (130) [138] mark for center of neck. Knit to R 162 (170) [178] then increase every 2 rows, 1 st. 5x. Mark with a bit of yarn R 172 (180) [188]. After R 175 (183) [191] Set Weaving Pattern left to right then continue in Weaving Pat.

same as before and AT THE SAME TIME, shape shoulder: Every 10 rows decrease 1 st. 5x. After R 228 (240) [256] bind off (or remove on W.Y.) 50 (55) [60] sts. then, every 2 rows decrease 1 st. 5x for armhole. After R 248 (260) [276] mark for center underarm then CONTINUE WITH THE FRONT SECTION. Put Counter at -0-. Knit 10 rows then shape armhole: every 2 rows increase 1 st. 5x. At R 20 cast on 50 (55) [60] sts. Every 10 rows inc. 1 st. 5x. At R 29 begin the Weaving, setting Pat. left to right same as back. After R 72 (80) [88] mark with a bit of yarn, then SHAPE NECK: Bind off 4 sts. 1x, then every 2 rows decrease 1 st. 10x. Mark center after R 122 (130) [138] then knit to R 152 (160) [168]. Every 2 rows increase 1 st. 10x, then 4 sts. 1x. Mark with a bit of yarn at R 172 (180) [188] After R 175 (183) [191] set Weaving Pattern same as before and AT THE SAME TIME shape shoulder, every 10 rows decrease 1 st. 5x. After R 228 (240) [256], bind off (or remove on W.Y.) 50 (55) [60] sts. then every 2 rows decrease 1 st. 5x. Knit to R 248 (260) [276] and bind off or remove the sts. on W.Y.

SLEEVES: K1, P1 Rib. With Col. 1 and Col. 3 (elastic), cast on 76 (80) [84] sts. Knit to R 36. Transfer Rib sts. to MB. Put Counter at -0-. Continue in St. st. with Col. 1 only. **ON EACH SIDE,** every 6 rows, increase 1 st., 25 (26) [27]x. After R 150 (156) [162] SHAPE CAP: **ON EACH SIDE,** bind off

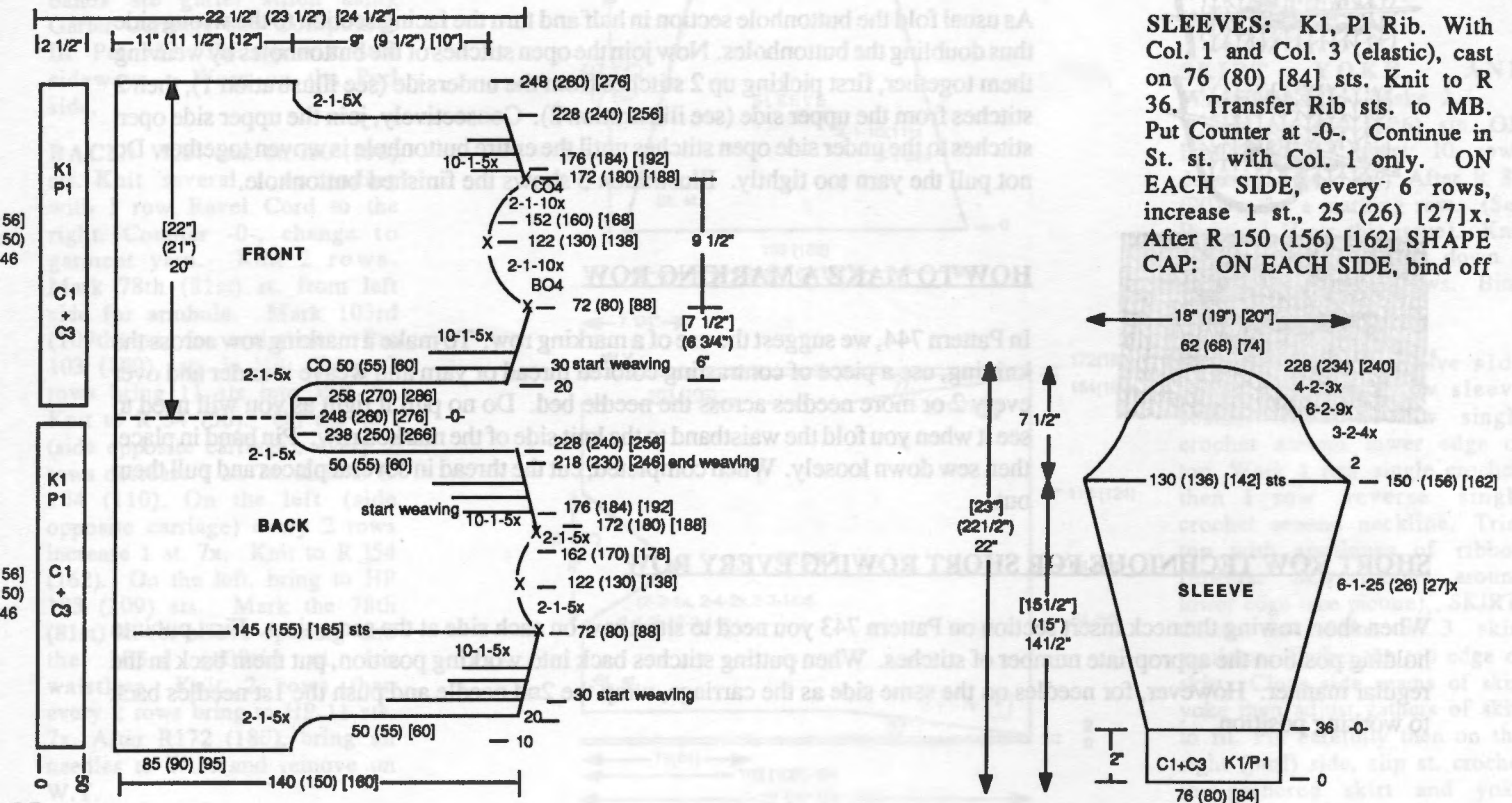

2 sts. then every 3 rows bind off 2 sts. 4x; every 6 rows 2 sts. 9x; every 4 rows 2 sts. 3x. After R 228 (234) [240], bind off the remaining sts.

NECK BAND: Close 1 shoulder first. Bring 144 (148) [152] ndls. to W.P. With knit side facing, pick up sts. around neckline and hang onto these ndls. 66 (68) [70] across the back and 78 (80) [82] sts, across the front. With T 4, knit 2 rows, with T 3, knit 12 rows. Pick up first row of band to form hem. Bind off loosely.

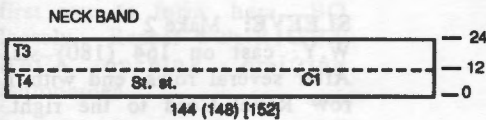

WAISTBAND FOR TOP: Make 2. K1, P1 Rib. With Col. 1 and Col 3 (elastic) cast on 146 (150) [156] sts. Knit 50 rows. Transfer Rib sts. to MB pick up the waist edge of front or back with knit side facing

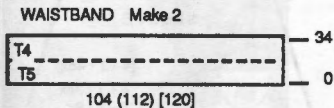

you and gathering evenly across onto these ndls. Bind off loosely.

SKIRT: The Back and Front are the same with exception of back slit at lower edge of skirt. Knit the back first, then knit the front, omitting slit. To the left of -0-, cast on 74 (78) [82] sts. in the following manner. With Col. 1 and Col. 4 (matching sewing thread), leave a long end on the left and bring every 2nd ndl. to holding position. 'e' cast on over these ndls. and put the two strands into feeder. Push these ndls. back to -D- position and bring the alternate ndls. to HP and with long strand hanging on the left, 'e' cast on over these ndls. Hang the Cast on Comb carefully into the cast on sts. and bring them all to holding position. Knit st. st. Begin side shaping immediately while knitting in st. st. and weaving pattern, every 10 rows increase 1 st. 7x. Begin with T 3 and

knit 4 rows, change to T 3.2, knit 4 rows, T 4, knit 4 rows, T 4.2 knit 4 rows Continue to R 25 (29) [33], set Weaving Pat. left to right. Work 4 rows Weaving with Col. 2, 8 rows St. st. Continue in weaving pattern to R 66 (70) [74]. After R 70 (72) [76] remove the sts. on W.Y. For the 2nd half, cast on in the same way to the RIGHT OF -0- and work the weaving side shaping and tension increases in the same manner. After R 70 (72) [76] hang the left side onto the machine OVERLAPPING 6 sts. in the center to form a facing. Continue with Tension 5 and st. st. After R 160 (170) [180], ON EACH SIDE, every 10 rows decrease 1 st. 7x. After R 230 (240) [250], work short rows. ON OPPOSITE SIDE OF CARR. bring 50 ndls. to HP, knit across (be sure to always wrap inside needle when working short rows), then bring 50 ndls. opposite Carr. to HP. knit across. On every 2nd row bring back to WP 10 sts. 5x ON EACH SIDE. After R 240 (250) [260], remove the sts. on W.Y. Work the front skirt section the same, omitting the slit and casting on the full amount of 136 (144) [152] sts.

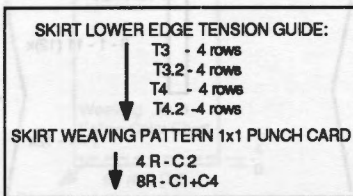
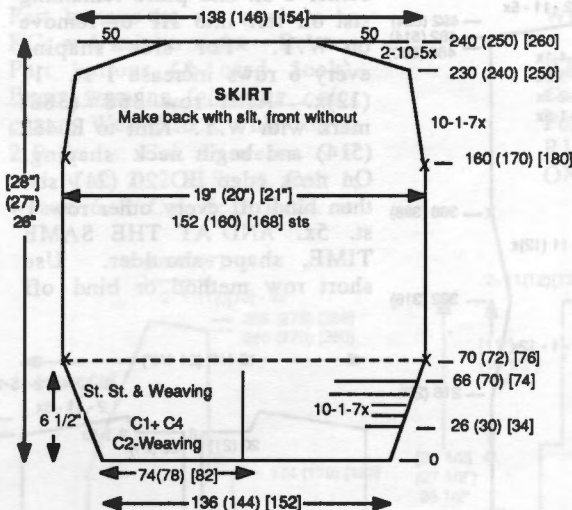

SKIRT WAISTBAND:

Make 2. Bring 102 (112) [120] ndls. to WP. With knit side facing, hang the open sts. of skirt waist onto these ndls. decreasing evenly across. With T 5, knit 17 rows. With T 4, knit 17 rows. Pick up first row of band and hang onto these ndls. B. O. loosely.

FINISHING: See General Instructions. Insert elastic through casing of skirt waistband.

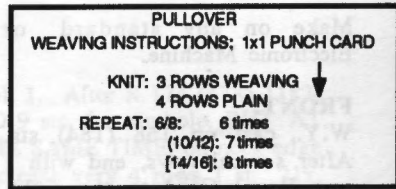

***745 - Weaving Pattern**

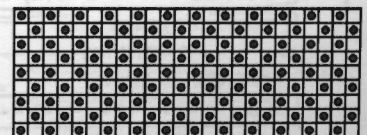



SHEATH DRESS

YARN: Roma
SIZES: 6/8 (10/12)
AMOUNT: 20 oz 24 oz
KIT PRICE: \$24.00 \$28.50
TENSION: 4
GAUGE: 17 sts. 24 rows = 2" (5 cm)
NOTIONS: 10 Buttons, approx. 1/2"

Make on any standard or Electronic Machine.

FRONT:
 W.Y. cast on 168 (184) sts. After several rows, end with 1 row Ravel Cord to the right. Change to garment yarn. At T 4

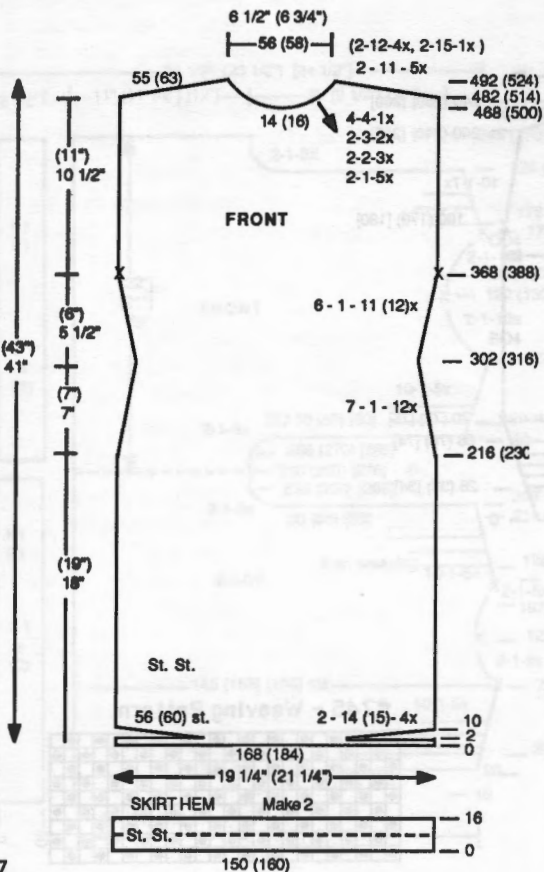

knit 2 rows and set carriage for Short Row knitting. *ON LEFT SIDE, bring 56 (60) ndls. to HP. Knit across (be sure to wrap inside ndl. to prevent holes). Repeat from * for right side. ON OPPOSITE SIDE OF CARRIAGE push back to WP 14 (15) sts. every other row 4x on each side. Continue in st. st. After R 216 (230) every 7 rows decrease 1 st. 12x. After R 302 (316) every 6 rows increase 1 st. 11 (12)x. After R 368 (388) mark both sides with W.Y. Knit to R 468 (500). BO the center 14 (16) sts. Place the sts. on the left into HP or remove on W.Y. Using short row method or bind off *on neck edge every two rows decrease 1 st. 5x, every 2 rows 2 sts. 3x, every 2 rows 3 sts 2x and every 4 rows 4 sts 1x. AT THE SAME TIME, after R 482 (514) shape shoulder. Using short row method or bind off every 2 rows 11 sts 5x (every 2 rows 12 sts 4x, 15 sts 1x). After R492 (524) remove remaining sts. on W.Y. Bring sts. on left back into WP. Turn counter back to R 468 (500) and knit left half following instructions from *.

BACK:
 Knit same as Front until R 302 (316). After R 302 (316) BO center 6 st. and place remaining sts. on left into HP or remove on W.Y. *For side shaping every 6 rows increase 1 st. 11 (12)x. After row 368 (388) mark with W.Y. Knit to R 482 (514) and begin neck shaping. On neck edge BO 20 (21) sts. then bind off every other row 1 st. 5x. AND AT THE SAME TIME, shape shoulder. Use short row method or bind off

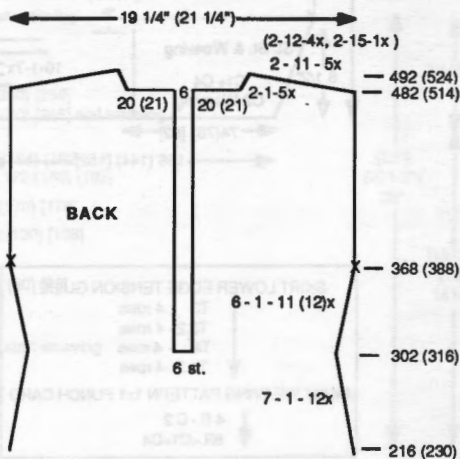

every 2 rows 11 sts. 5x, (every 2 rows 12 sts. 4x; 15 sts. 1x). Bring sts. on left back into WP. Turn counter back to R 302 (316) and knit left half following instructions from *.

SKIRT HEM: Make 2
 W.Y. cast on 150 (160) sts. After several rows, end with 1 row Ravel Cord to the right. Change to garment yarn. Knit 16 R st. st. Pick up first row to form hem. With purl side facing, hang open sts. of Front onto these ndls. decreasing evenly across. BO loosely. Repeat for Back.

SLEEVE: Make 2
 W.Y. cast on 164 (180) sts. After several rows, end with 1 row Ravel Cord to the right. Change to garment yarn. On each side every 5 rows decrease 1 st. 8x, every 4 rows 1 st. 34x (every 4 rows 1 st. 45x). After R 180 (190) remove remaining sts. on W.Y.

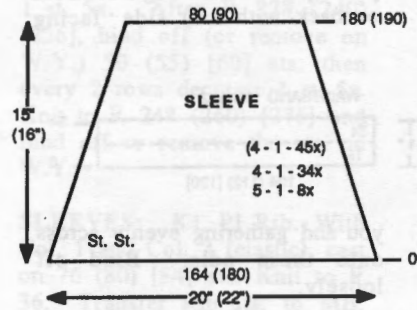

CUFF: Make 2
 W.Y. cast on 46 (50) sts. After several rows, end with 1 row Ravel Cord to the right. Change to garment yarn. Knit 16 R st. st. Pick up first row to form hem. With purl side facing, hang open sts. of Sleeve onto these ndls. decreasing evenly across. BO loosely.

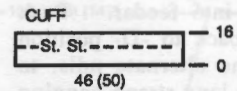

CENTER BACK BAND:
 Make 1 plain, 1 with buttonholes

Put 108 (116) ndls to WP. With purl side facing hang center back opening of garment onto these ndls and knit 7 rows st. st. and

make first half of buttonholes. Counting carefully from the left ndl., leave 4 ndls., place a small piece of ravel cord in next 3 ndls. and manually knit through, leave next 9 (10) ndls. alone, place ravel cord in next 3 ndls. Continue following needle count on chart. Knit to R 17. Make

CENTER BACK BAND Make 2 (1 with buttonholes, 1 without)

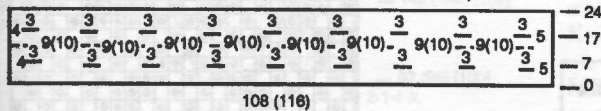

108 (116)

second half of buttonholes as before. Knit to R 24. Pick up first row to form hem. BO loosely. Repeat with RIGHT BACK opening omitting buttonholes.

NECK BAND: Make 1

Weave both shoulder seams. Move 132 (132) ndls to WP. With purl side facing hang entire neck opening (including back center band) onto these ndls. Knit st. st. to R 12. Make first half of buttonhole (see CENTER BACK BAND). After R36 make second half of buttonhole. After R 48 pick up first row to form hem. BO loosely.

FINISHING:

Refer to General Instructions. See Knitkng News for buttonhole finishing.

NECK BAND

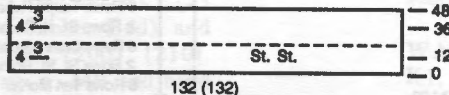

132 (132)

747



WOVEN VEST

YARN:

- Col. 1: Beige Roma
- Col. 2: Cream Rubane
- Col. 3: Taupe Rubane
- Col. 4: Beige/Grey Pebble
- Col. 5: Tan Mohair
- Col. 6: Monofil

SIZES: 6/8 (10/12) [14]

AMOUNT:

- Col. 1: 1 cone all sizes
- Col. 2: 1 ball all sizes
- Col. 3: 1 ball all sizes
- Col. 4: 2 oz all sizes
- Col. 5: 2 oz all sizes
- Col. 6: 1 spool monofil

KIT PRICE: \$40.00

TENSION: Weaving T 7, K1P1 Rib: 1/1(Arm band); T 7/7 (Front Band)

GAUGE: 13.4 sts. 20.22 R = 2" (5 cm)

Make on any Standard or Electronic Machine with Ribber.

FRONT: Make 1, Reverse

With Col. 1 circular cast 64 (68) [72] sts. Knit 4 R, transfer ribber sts. to MB. Set pattern: Push both Part buttons in and without yarn, knit to left. Leave Part buttons in, set carriage to KC, and knit to right. Release Part buttons (& card lock). Begin weaving following color chart. Weave 10 R with Col. 4; 2 R St. st. Col. 1; weave 6 R with Col. 2; 2 R St. st. Col. 1; weave 6 R Col. 5; 2 R St. st.

Col. 1. After R 174 (178) [182] BO 9 sts. for armhole, BUT AT THE SAME TIME, on neck edge decrease very 4 rows 1 st. 21x, every 6 rows 1 st. 1x (2x) [3x]. After R 260 (270) [280] Short Row shoulders: every other row 11 (12) [13] sts. 3x. After R 268 (278) [188] return ndls. to WP and remove on W.Y.

BACK: Make 1, reverse 1

Cast on 126 (134) [142] sts. Follow instruction for Front to R174. After R 174 BO 8 sts. ON EACH SIDE. Continue

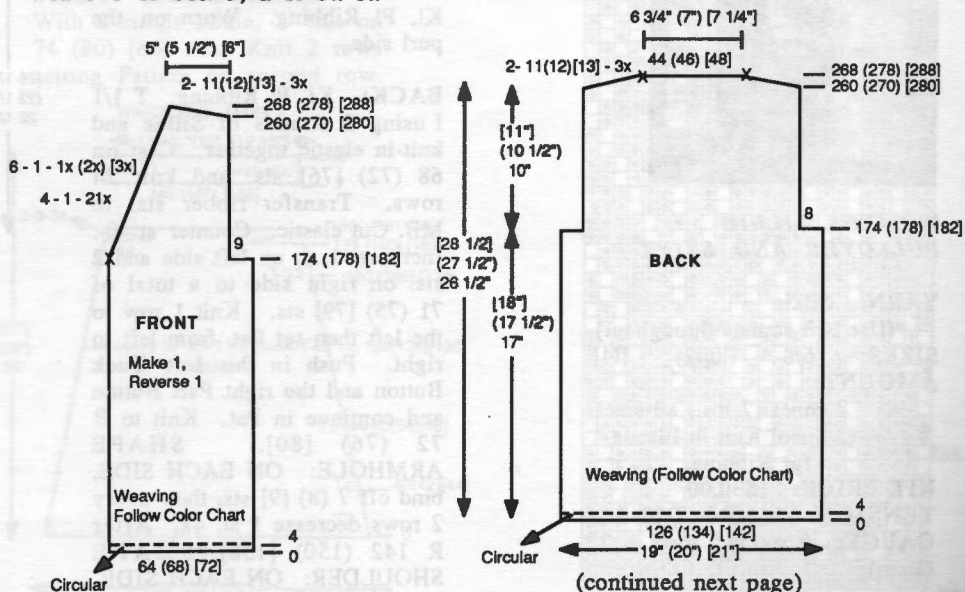

(continued next page)

(continued from previous page) weaving in pattern to R 260 (270) [280]. Short Row shoulders: every other row 11 (12) [13] sts. 3x. After R 268 (278) [288] return ndls. to WP, mark neck sts. and remove on W.Y.

ARM BAND: Make 2
Weave shoulder seams. K1P1 Rib: With Col. 1 cast on 156 (160) [164] sts. After selvedge, knit 32 R. Transfer rib sts. to MB. With knit side facing, hang sts. of armhole onto these ndls. BO loosely. See Finishing for hem.

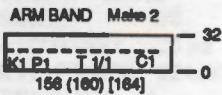

COLLAR AND FRONT BAND: Make 2.
T 7/7 (7/7) [7.1/7.1]
K1P1 Rib: With 2 strands of Col. 1 and 1 strand Col. 6 (monofil) cast on 192 (200) [200 - one point looser tension] sts. After R 16 (18) [18] transfer 140 (144) [144] sts. on left to

MB and BO. On left, every other row decrease 2 sts. 12x (13x) [13x]. After R 40 (44) [44] transfer sts. to MB and BO.

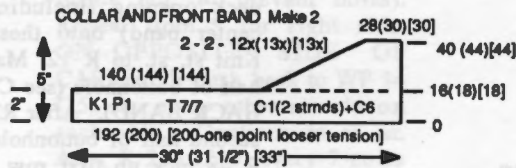

COLOR CHART FOR WEAVING PATTERN

START: 4 Rows Circular in Main Color

CONTINUE:

- 10 Rows Pebble
- 2 Rows St. st. Roma
- 6 Rows Taupe Rubane
- 2 Rows St. st. Roma
- 6 Rows Cream Rubane
- 2 Rows St. St. Roma
- 8 Rows Tan Mohair
- 2 Rows St. St. Roma

FINISHING:
Slip stitch open sts. of neck. Weave center back seam of collar and stitch bands to front

and neck. Form hem on arm band and stitch ends of arm bands to armhole. See General Instructions.

#747 - Woven Vest

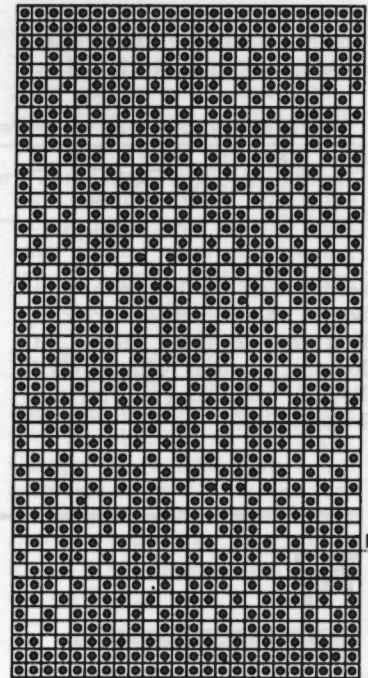

748



WOMENS SILKIE PULLOVER AND SKIRT

YARN: Silkie
(Use two strands throughout)
SIZES: 6/8 (10/12) [14]
AMOUNT:
2 cones (2 lbs.) all sizes
2 Spool Knit-in Elastic for Ribbing.
KIT PRICE: \$30.00
TENSION: 4. Rib. T 1/1 I
GAUGE: 8 sts. 14.5 rows = 2" (5 cm)

Make on any Punch Card Bulky machine with Ribbing Attachment.

The Pattern is a combined Tuck and Skip stitch. Push in the left Tuck Button and the right Part Button. Punch Card. Bands are K1, P1 Ribbing. Worn on the purl side.

BACK: K1, P1 Ribbing. T 1/1 I using 2 strands of Silkie and knit-in elastic together. Cast on 68 (72) [76] sts. and knit 24 rows. Transfer ribber sts. to MB. Cut elastic. Counter at 0-. Increase 1 st. on left side and 2 sts. on right side to a total of 71 (75) [79] sts. Knit 1 row to the left then set Pat. from left to right. Push in the left Tuck Button and the right Part Button and continue in Pat. Knit to R 72 (76) [80]. **SHAPE ARMHOLE:** ON EACH SIDE, bind off 7 (8) [9] sts. then every 2 rows decrease 1 st. 4x. After R 142 (150) [158], **SHAPE SHOULDER:** ON EACH SIDE,

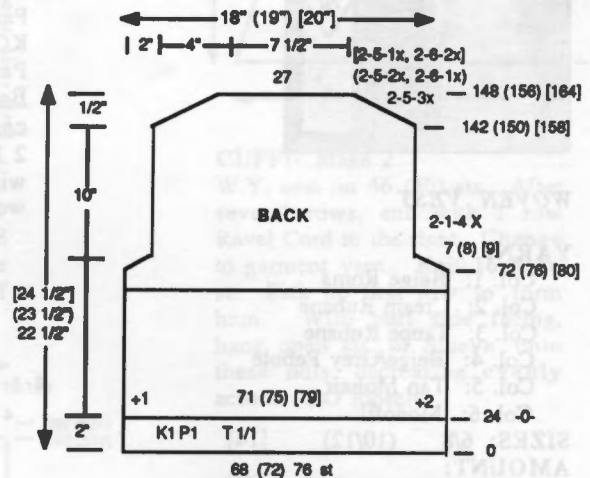

bind off or short row every 2 rows 5 sts. 3x (every 2 rows 5 sts. 2x, 6 sts. 1x) [every 2 rows 5 sts. 1x, 6 sts. 2x]. After R 148 (156) [164] bind off the remaining sts.

FRONT: Use 2 strands of Silkie same as for back. Work the front the same as the back to R 92 (96) [100]. Bind off the center 12 sts. put the ndls. on

the left into holding position and complete the right side first. **MARK DOWN PATTERN NUMBER ON CARD.** *ON NECK EDGE, every 8 rows decrease 1 st. 7x (every 8 rows 1 st. 7x) [every 9 rows 1 st. 7x] and AT

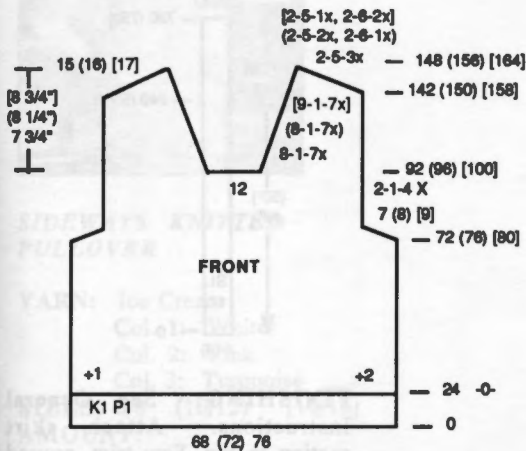

THE SAME TIME, after R 142 (150) [158] SHAPE SHOULDER same as the back. Bring the ndls. on the left back into working position (be sure sts. are in the hooks of ndls.) Put Counter back to 92 (96) [100] Set correct pattern row and complete the left half following instructions from *.

SLEEVES: With W.Y. cast on 58 (60) [62] sts. After ending with Ravel Cord row from right to left change to 2 strands Silkite and knit 1 row to the right to set pattern. Set card to "go". Continue in pattern. ON EACH SIDE, every 17 (18) [19] rows increase 1 st. 5x. After R 86 (90) [96], SHAPE CAP: ON EACH SIDE, bind off 4 (5) [6] sts., then every 2 rows bind off 1 st. 19 (21) [23]x; and EVERY ROW 1 st. 6 (4) [2]x. After R 130 (136) [142] bind off the remaining sts.

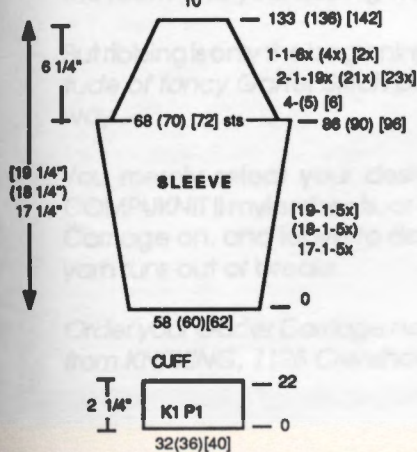

CUFF: K1, P1 Rib. Bring 32 (36) [40] ndls to WP. Rehang the open sts. of sleeve with purl side facing you. You must bring the sleeve section UP BETWEEN THE KNITTER AND RIBBER in order to knit the cuff. Decrease sts. evenly across. Use 2 strands Silkite and knit-in elastic. Knit 1 row T 4 on MB and transfer every 2nd st. to the ribber. At T 1/1 I knit 22 rows. Knit 1 row with T 10 on MB, T 5 on Ribber. Transfer the sts to MB then latch off the crochet method.

COLLAR and TIE: FNR: T 2/2 I. Single strnd Silkite. Cast on 47 sts. (23 Main Bed, 24 Ribber Bed) and knit to R 190 (200) [210]. Transfer Rib sts. to MB and bind off loosely.

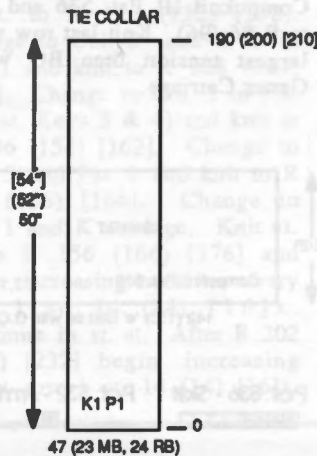

SKIRT: Make 2 sections With 2 strnds Silkite, 'e' cast on 74 (80) [86] sts. Knit 2 rows setting Pattern on second row.

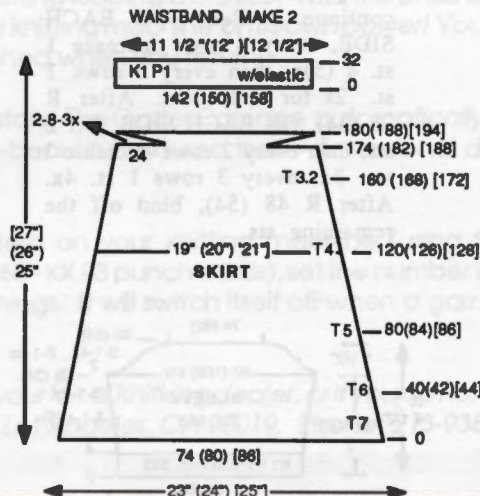

With T 7, knit to R 40 (42) [44]. Change to T 6, knit to R 80 (84) [86]. Change to T 5, knit to R 120 (126) [128]. Change to T 4, knit to R 160 (168) [172]. Change to T 3.2 knit to R 174 (182) [188]. Work Short Rows. ON OPPOSITE SIDE OF CARR. bring 24 sts. to holding position on the next 2 rows. (Be sure to always wrap the inside ndl. in HP when knitting short rows.) ON OPPOSITE OF CARR. push back to working position 8 sts. 3x ON EACH SIDE. After R 180 (188) [194] knit 1 row across in st. st., then remove on W.Y. Make a second section the same.

WAISTBAND: Make 2. K1, P1. T 0.2/0.2 I. Two strnds Silkite plus 2 strands knit-in Elastic Thread. Cast on 142 (150) [158] sts. Knit 32 rows. Transfer Rib sts. to MB. With wrong side facing, hang the open sts. onto these ndls. decreasing evenly across. B O loosely.

FINISHING: See General Instructions. Fold Tie in half and pin to center back neck then sew in place around neckline on each side to the front opening. Slip st. crochet across the center neck. Tie in bow.

Punch Card for Pattern #748

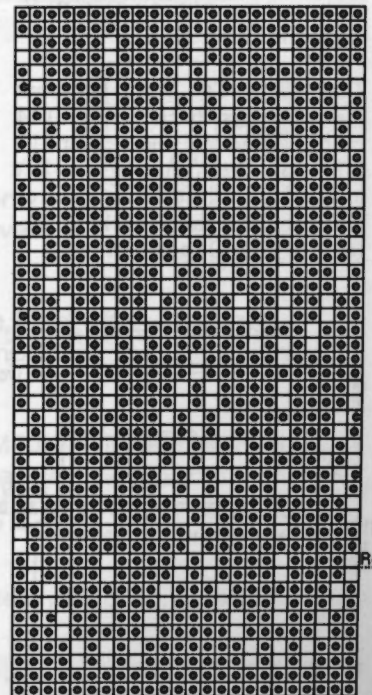



LITTLE GIRLS GARTER CARRIAGE DRESS

YARN: Amore
SIZE: 3/4 5/6
AMOUNT: 7 balls all sizes
KIT PRICE: \$16.00
TENSION: G.C.: 7.1
GAUGE: 14 sts. 23 Rows = 2" (5 cm)

Make on the Compuknit III or Standard Punch Card machine with Garter Carriage. Compuknit III machine owners use Pat. 546 for Top section, Pat 536 for skirt section, Punch card machine owners, punch cards.

TOP BACK: 'e' cast on 92 (100) sts. Set Compuknit III Pat. 546. Knit to R 96 (102). **SHAPE ARMHOLE: ON EACH SIDE,** bind off 2 (3) sts. then on every 2 rows decrease 1 st. 3x. Knit to R 170 (182). Mark the neck opening with a bit of W.Y. then remove on W.Y.

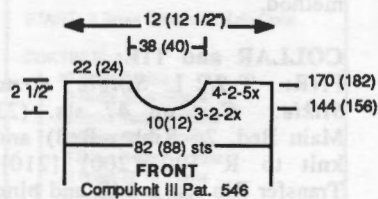

TOP FRONT: Work the front the same as back to R 144 (156). Bind off the center 10 (12) sts., then remove the left half onto contrast waste yarn or you can knit them back to -A- (out of work) position with a

ravel cord. Complete the right side first. *ON NECK EDGE, every 3rd row bind off 2 sts. 2x; every 4th row 2 sts. 5x. After R 170 (182), bind off (or remove on W.Y.) the remaining sts. Hang the left side sts. (or bring them back to WP) onto the machine (be sure they are on the correct ndls and in the hooks). Counter back to 144 (156). Complete the left half following the instructions from *.

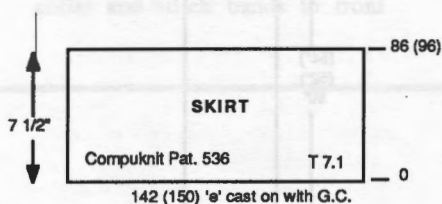

SKIRT: Make 2 sections. 'e' cast on 142 (150) sts. Set Compuknit III Pat. 536 and knit to R 86 (96). Knit last row with largest tension then BO with Garter Carriage.



Pat. 536 - Skirt  Pat. 532 - Arm Band 

SLEEVES: Compuknit III Pat. 532 for K1 P1 rib band. 'e' cast on 80 (86) sts. Work 4 rows K1 P1 rib then change to Compuknit III Pat. 546 and continue in Pat. ON EACH SIDE, every 4 rows increase 1 st. 4 (5)x; then every 5 rows 1 st. 2x for both sizes. After R 28 (34), ON EACH SIDE, BO 2 sts. then every 2 rows decrease 1 st. 3x; every 3 rows 1 st. 4x. After R 48 (54), bind off the remaining sts.

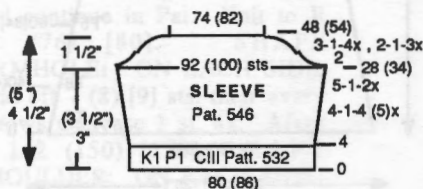

TRIM: (to go around dropped waistline). Cast on 6 sts. and knit St. st. After R 540 (550), mark each side with W.Y. Knit to R 730 (750). BO.

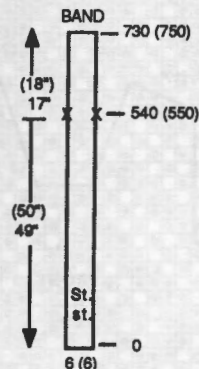

FINISHING: See General Instructions. Attach skirt section to top. Sew trim around waist to cover seam and tie in bow at front (see picture).

Pat. 546 - Dress Bodice

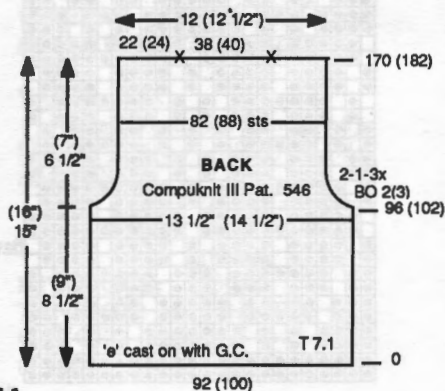
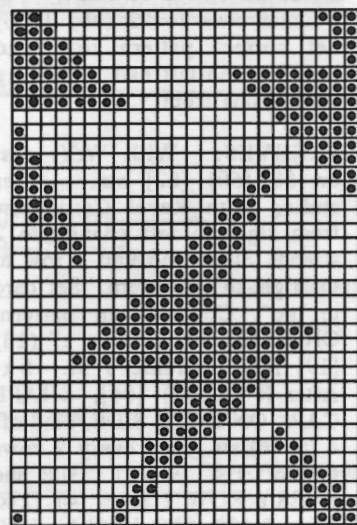



SIDEWAYS KNITTED PULLOVER

YARN: Ice Cream

Col. 1: White

Col. 2: Pink

Col. 3: Turquoise

SIZES: 6/8 (10/12) [14/16]

AMOUNT:

Col. 1: 1 lb. all sizes

Col. 2: 3 oz all sizes

Col. 3: 3 oz all sizes

KIT PRICE: \$39.50

TENSION: G C: T 8, K Carr:

T 9, Rib: T3.1 G C

GAUGE: 13 sts. 16 rows = 2"

(5 cm)

Make on any standard machine with Garter Carriage.

FRONT:

Starting at ndl. 64 (70) [76] to the right of -0- and K carriage, W.Y. cast on 36 (40) [44] sts. After several rows, end with 1

row Ravel Cord to the right. Change to Col. 2, G. C., set Pat. 1 (Compuknit III Pattern 537) and knit 10 (10) [10] rows. AT THE SAME TIME, increase on the left side every 6 rows 1 st. 5x, every 4 rows 1 st. 5x, every 3 rows 1 st. 6x, every other row 1 st. 14x, every row 1 st. 10 (14) [18]x. Change to Col. 1 and K carriage. Knit St. st. to R 38 (40) [42]. Change to Col. 3 and G. C. with Pat. 2 (Compuknit III Pattern #461 with Variation Keys 3 & 4). Knit to R 48 (50) [52]. Change to Col. 1 & K carriage. Knit st. st. to R 76 (80) [84]. Change to Col. 2, G.C. and Pat. 1 and knit to R 86 (90) [94]. Change to Col. 1, in Pat. 2 (use Variation Keys 3 & 4) and knit to R 96 (100) [104]. Change to Col. 3 in Pat. 1 and knit to R 106 (110) [114]. Cast on 52 (56) [60] sts. to the left. Change to Col. 1 and K carriage. Knit st. st. to R 126 (132) [138]. Change to Col. 2 and G C. in Pat. 1 and knit to R 128 (134) [140]. Change to Col. 1 in Pat. 2 (Var. Keys 3 & 4) and knit to R 146 (154) [162]. Change to Col. 3 and Pat. 1 and knit to R 148 (156) [164]. Change to Col. 1 and K carriage. Knit st. st. to R 156 (166) [176] and begin decreasing neckline every row 1 st. 14 (14) [16]x. Continue in st. st. After R 202 (216) [232] begin increasing every row 1 st. 14 (14) [16]x.

Knit to R 248 (266) [290]. Change to Col. 3 and G C. in Pat. 1 and knit to R 258 (276) [300]. Change to Col. 1 and Pat. 2 (Var. Keys 3 & 4) and knit to R 268 (286) [310]. BO 52 (56) [60] sts. on left. Change to Col. 2 and Pat. 1 and knit to R 278 (296) [320] BUT AT THE SAME TIME begin decreasing on left every row 1 st. 10 (14) [18]x, every 2 rows 1 st. 14x; every 3 rows 1 st. 6x; every 4 rows 1 st. 5x; every 6 rows 1 st. 5x. Change to Col. 1 and K carriage. Knit to R 316 (336) [362] in st. st. Change to Col. 3 and G. C. Pat. 2 Knit to R 326 (346) [372]. Change to Col. 1 and K carriage. Knit in st. st. to R 364 (386) [414]. Change to Col. 2 and G C. Pat. 1. Knit to R 374 (396) [424]. Remove remaining sts. on W.Y.

BACK:

Starting at ndl. 64 (70) [76] to the left of -0-, W.Y. cast on 36 (40) [44] sts. Follow remaining instructions for Front, reversing references to left and right.

NECK BAND: Make 1

Close one shoulder. With G.C. on T 3.1 and K1P1 rib pattern, CO 122 (126) [126] sts. Knit 20 rows. With purl side facing hang sts. of neck onto these ndls. BO loosely. Close remaining shoulder seam.

(continued next page)

THE GARTER CARRIAGE KNITS RIBBING AUTOMATICALLY AND MUCH, MUCH MORE!!

The KnitKing Garter Carriage makes knitting Ribbing a breeze. With the press of a button, the Garter Carriage moves across your knitting machine *on its own power!* You can leave the room and your ribbing will be finished when you return!

But ribbing is only the beginning of the story: The Garter Carriage *automatically casts on, binds off and knits a multitude of fancy Garter Stitch patterns*—beautiful textured three-dimensional designs impossible to knit any other way.

You merely select your desired pattern on your knitting machine (using the COMPUKNIT III keyboard, the COMPUKNIT II mylar sheets, or the KH 860 - KK 93 punch cards), set the number of rows needed, switch your Garter Carriage on, and leave to do other things. It will switch itself off when a garment section is completed or if the yarn runs out or breaks.

Order your Garter Carriage now from your local KnitKing dealer, or if you do not have one in your area, order direct from KNITKING, 1128 Crenshaw Blvd., Los Angeles, CA 90019. Phone: 213-938-2077.

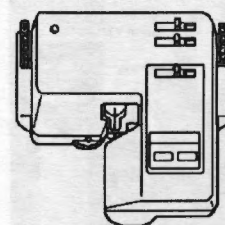

(continued from previous page)

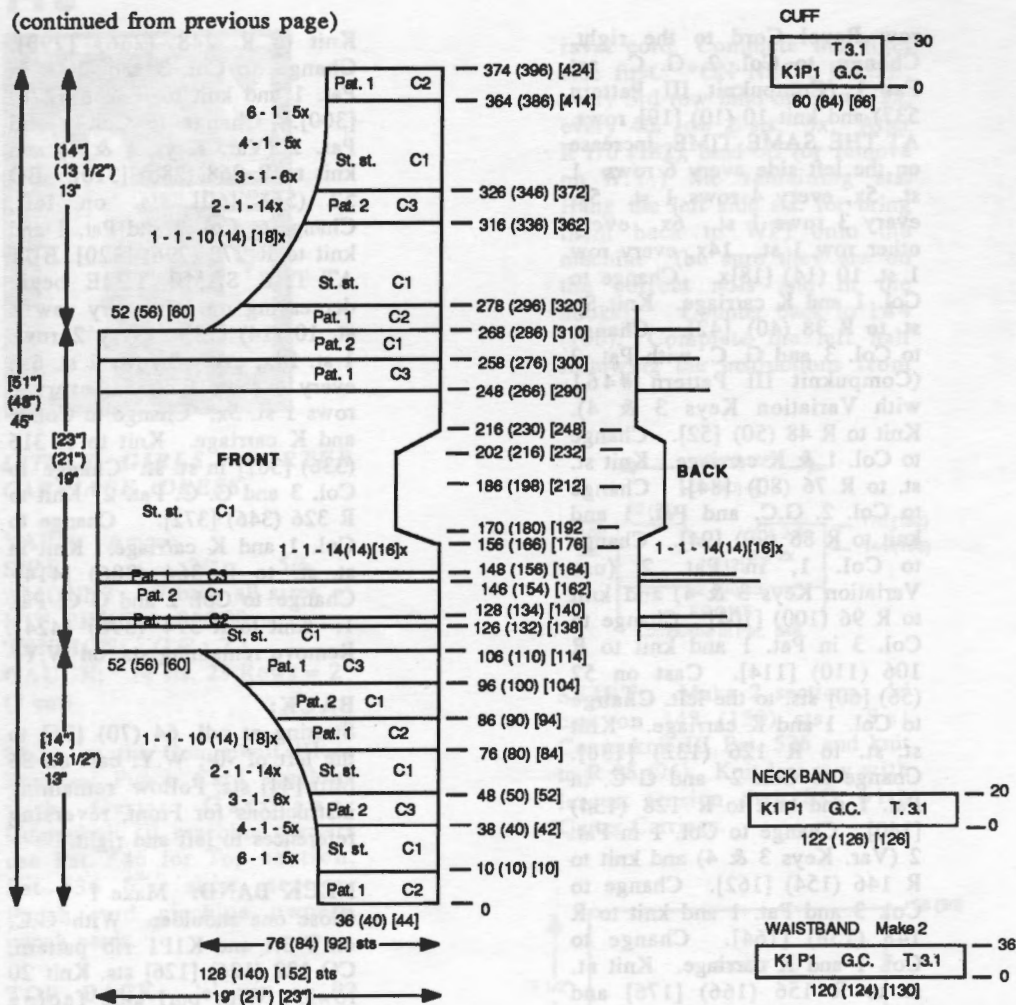

CUFF: Make 2

With G C set on T 3.1 and K1P1 rib pattern, CO 60 (64) [66] sts. Knit 30 R. With purl side facing, hang open sts. of Sleeve onto these ndls, decreasing evenly across. BO loosely. Repeat for other sleeve.

WAISTBAND: Make 2

With G.C. set on T 3.1 and K1P1 rib pattern, CO 120 (124) [130] sts. Knit 36 rows. With purl side facing, hang sts. of Front onto these ndls, decreasing evenly across. BO loosely. Repeat for BACK.

FINISHING:

See General Instructions.

Pat. 2 #461



Pat. 1 #537



751



WOMENS FAIRISLE DRESS

YARN: Pearlyte

SIZES:

6/8 (10/12) [14/16]

AMOUNT:

Col. 1 1 cone (16 oz) all sizes

Col. 2 1 cone (16 oz) all sizes

Knit in Elastic - 1 Spool for

all sizes.

KIT PRICE: \$38.00

TENSION: T 5 - Ribbing

Tension as per instructions.

GAUGE: 17 sts, 22.5 Rows = 2" (5 cm)

Make on any Electronic or Standard Punch Card machine. COMPUKNIT III, Pat. No. 529 Fair Isle Design in Compuknit III Pattern Book.

Bands are K1, P1 Ribbing.

BACK: FNR: With Col. 1, cast on 150 (160) [170] sts. After selvedge, with T 3.2/3.2 I, knit 8 rows circular (16 rows). Transfer rib sts. to MB and put counter at -0-. Change to T 5, knit 1 row to the left then set Fair Isle Pattern to the right. Insert Col. 2 in 'B' feeder and continue in Pat. ON EACH SIDE, every 18 (20) [22] rows

inc. 1 st. 5x. After R 90 (100) [110], mark each side with bit of contrast yarn. After R 316 (320) [324] mark each side with bit of contrast yarn for armhole. After R 420 (430) [440], bind off the center 18 (20) [22] sts., put the ndls. on the left into HP and complete the right side first. Be sure to mark down Pattern Row number. *SHAPE SHOULDER AND NECK AT THE SAME TIME. For shoulder: Every 2 rows BO 4 sts. 10x, then BO the remaining sts. For neck: Every 2 rows BO 3 sts. 10x. Bring the ndls. on the left into WP. Be sure sts. are in the hooks of needles. Set Pattern for correct row, Row Counter back to 420 (430) [440] and complete the left half following instructions from *.

(continued next page)

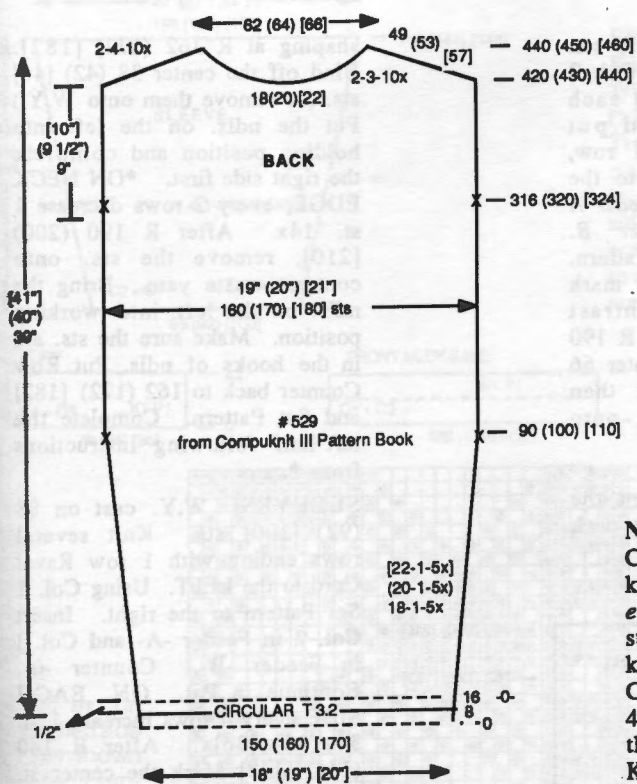

FRONT: Work the front the same as back to R 336 (340) [346]. Divide in the center and put the ndls. on the left into HP and complete the right side first. Mark down Pattern row number as you did before. *ON NECK EDGE, full fashion decrease every 6 rows 2 sts. 15 (16) [17]x, and after R 420 (430) [440] SHAPE SHOULDER same as the back. Bring the ndls. on the left back to WP (in the hooks of ndls). Set correct Pat. row. Counter to 336 (340) [346] and complete the left half following instructions from *.

RIGHT EDGE NECKBAND + BACK NECKBAND

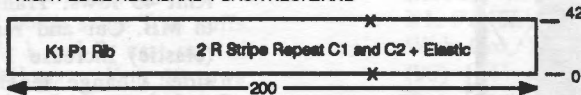

LEFT EDGE NECKBAND

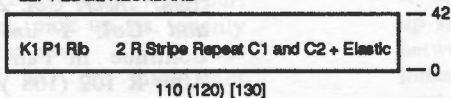

SLEEVE BAND

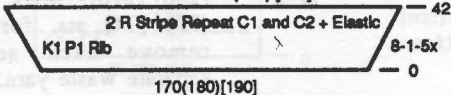

NECKBANDS: K1, P1 with Col. 1 and Col. 2 stripes with knit in elastic. T 1/1 I. *Right edge neckband:* Cast on 200 sts. with Col. 1. After selvedge, knit the color stripes of 2 rows Col. 1, 2 rows Col. 2. After R 42, (end with 2 rows Col. 2) then transfer rib sts. to MB. Knit 1 loose row Col. 1 then BO the crochet method. *Left edge Neckband.:* Knit the same as Right edge band except cast on 110 (120) [130] sts.

BELT (or SCARF): St. st. T 5. Bring 59 ndls. to WP. With Col. 1, 'e' cast on over these ndls. Knit 1 row to the left, then *leaving 3 ndls. in WP, drop the next 2 sts. and repeat from * across. Knit 20 rows. Follow chart for color changes to R 48. Continue with Col. 1 to R 450, then knit the same Color stripes beginning with 4 rows Col. 2 at R 450. (see chart) and ending with 20 rows Col. 1. After R 498,

bring all empty needles to working position. Knit 1 loose row with Col. 1 at T 10 and BO loosely.

FINISHING: Close shoulders. With right sides together (bound off edge against neckline) Sew or single crochet the right edge band to neckline from shoulder across back neck and down to V then repeat for left neck edge band from shoulder to 'V' The band crosses on the front from right to left with left band under the right band.

BELT: Make fringe by wrapping yarn around a 5 1/2" cardboard then cut only 1 edge. With 2 strands Col. 1 and 2 strands Col. 2, fold in half and with crochet hook, pull yarn through every group of 3 sts. across each end and make knot. Trim fringe evenly to 5" length. (See Picture).

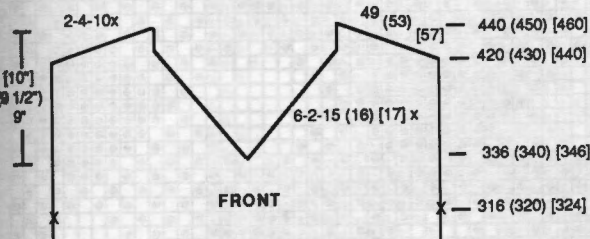

SLEEVE BANDS: Make 2. K1, P1 with Col. 1 and Col. 2 stripes with knit in elastic. T 1.2/1.2 I. With Col. 1, cast on 170 (180) [190] sts. After Selvedge, knit 2 rows Col. 1, 2 rows Col. 2 and repeat the color stripes AND AT THE SAME TIME, ON EACH SIDE, every 8 rows inc. 1 st. 5x. End with last 2 rows Col. 1. Transfer rib. sts. to MB. Knit 1 loose row with Col. 1, then BO the crochet method.

SCARF / BELT

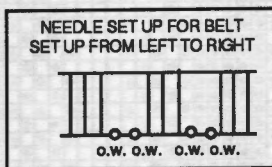
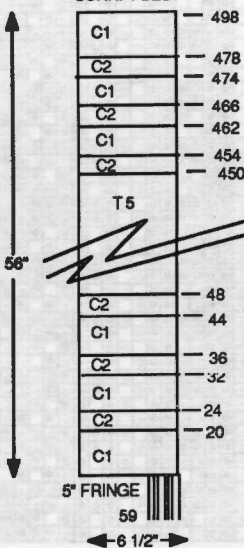

Pat. 529 - Fair Isle

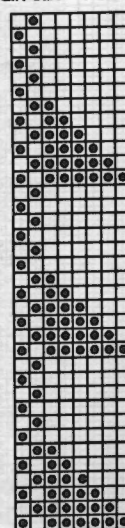



MENS FAIR ISLE PULLOVER

YARN: Silkie
SIZES: Small (Med) [Large]
AMOUNT:

- Col. 1: Black
1 Cone (16 oz.) all sizes
- Col. 2: Red
1 Cone (16 oz.) all sizes
- Col. 3 1 Spool Knit-in Elastic all sizes.

KIT PRICE: \$26.00
TENSION: 8; K1, P1 Rib 0.1/0.1 I
GAUGE: 15.5 sts., 17.5 Rows = 2" (5 cm)

A Fair Isle Design created on the KCIII Pattern Design Computer and made on the COMPUKNIT III machine with Ribbing Attachment.

BACK: K1, P1 Ribbing, T 0.1/0.1 I With Col. 1 and Col 3, cast on 162 (170) [178] sts.

Knit 43 rows. Transfer Rib sts. to MB. Cut and remove Col. 3 (elastic) Increase 1 st. on each side. Change tension and put Counter at -0-. Knit 1 row, setting Fair Isle Pattern to the right. *Insert Col. 2 in Feeder A and Col. 1 in Feeder B.* Continue in Fair Isle Pattern. After R 102 (108) [114], mark each side with bit of contrast yarn for sleeves. Knit to R 190 (200) [210]. Mark the center 66 (70) [74] sts. for neck then remove each section onto separate waste yarn.

FRONT: Work the front the same as the back up to the neck

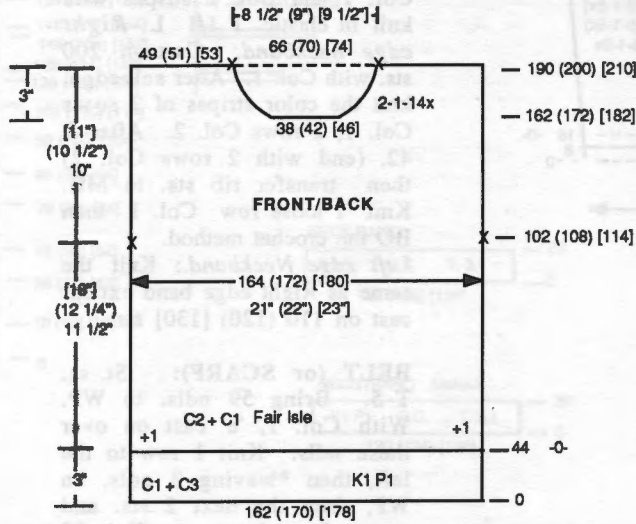

*752 Mens Fair Isle - Front/Back 180 sts. 48 rows

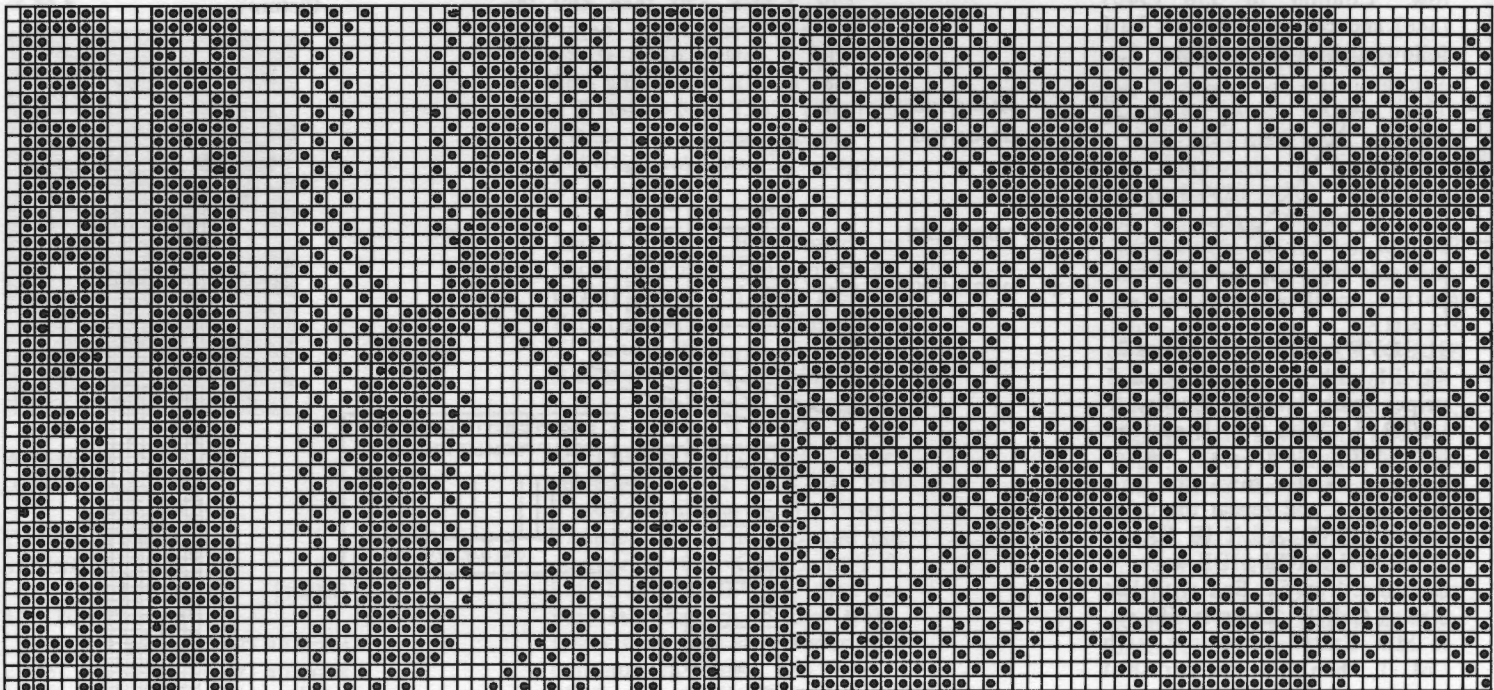

shaping at R 162 (172) [182]. Bind off the center 38 (42) [46] sts. (or remove them onto W.Y.) Put the ndls. on the left into holding position and complete the right side first. *ON NECK EDGE, every 2 rows decrease 1 st. 14x. After R 190 (200) [210], remove the sts. onto contrast waste yarn. Bring the ndls. on the left into working position. Make sure the sts. are in the hooks of ndls. Put Row Counter back to 162 (172) [182] and Set Pattern. Complete the left half following instructions from *.

SLEEVES: W.Y. cast on 88 (92) [100] sts. Knit several rows ending with 1 row Ravel Cord to the LEFT. Using Col. 1 Set Pattern to the right. Insert Col. 2 in Feeder -A- and Col. 1 in Feeder -B-. Counter -0-. Continue in Pat. ON EACH SIDE every 4 rows increase 1 st. 34 (35) [36]x. After R 140 (144) [148] Mark the center st. then bind off LOOSELY or remove on W.Y.

SLEEVE CUFFS: K1, P1 Ribbing. T 0.1 /0.1 I With Col. 1 and Col. 3, cast on 78 (84) [90] sts. Knit to R 44. Transfer the rib sts. to MB, cut elastic. With wrong side facing, hang the open sts. of sleeve onto these ndls. decreasing evenly across. With Col. 1, knit 1 LOOSE row then BO the latch tool method.

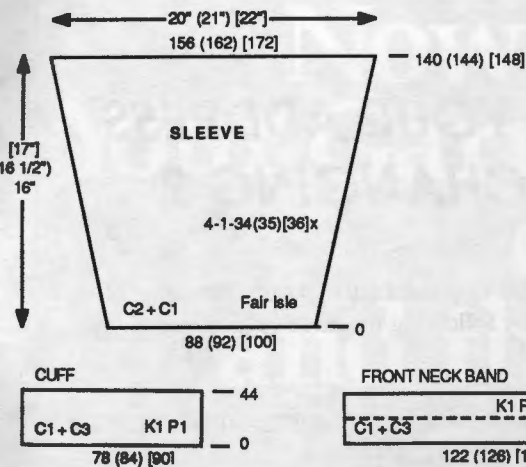

FRONT NECKBAND:

K1, P1 Ribbing same T as cuffs. With Col. 1 and 3, cast on 122 (126) [130] sts. Knit 40 rows. Transfer the rib sts. to MB. Cut elastic. Pick up first row of rib to double neckband. With purl side facing, pick up sts. evenly across front neck. Knit 1 loose row then BO the latch tool method.

BACK NECKBAND:

K1, P1 Ribbing same T as cuffs. With Col. 1 and 3, cast on 86 (90) [94] sts. Knit 40 rows. Transfer the rib sts. to MB, cut elastic. Pick up first row of rib to double neckband. Then pick up sts. evenly across back neck between marked stitches, knit 1 loose row then BO the latch tool method.

FINISHING: See General Instructions Close ends of neckband.

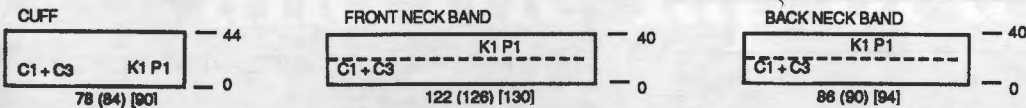

Add 48 sts. on right and left side of pattern shown here to complete sleeve. These sts. should be a repeat of the 24 end sts. as shown.

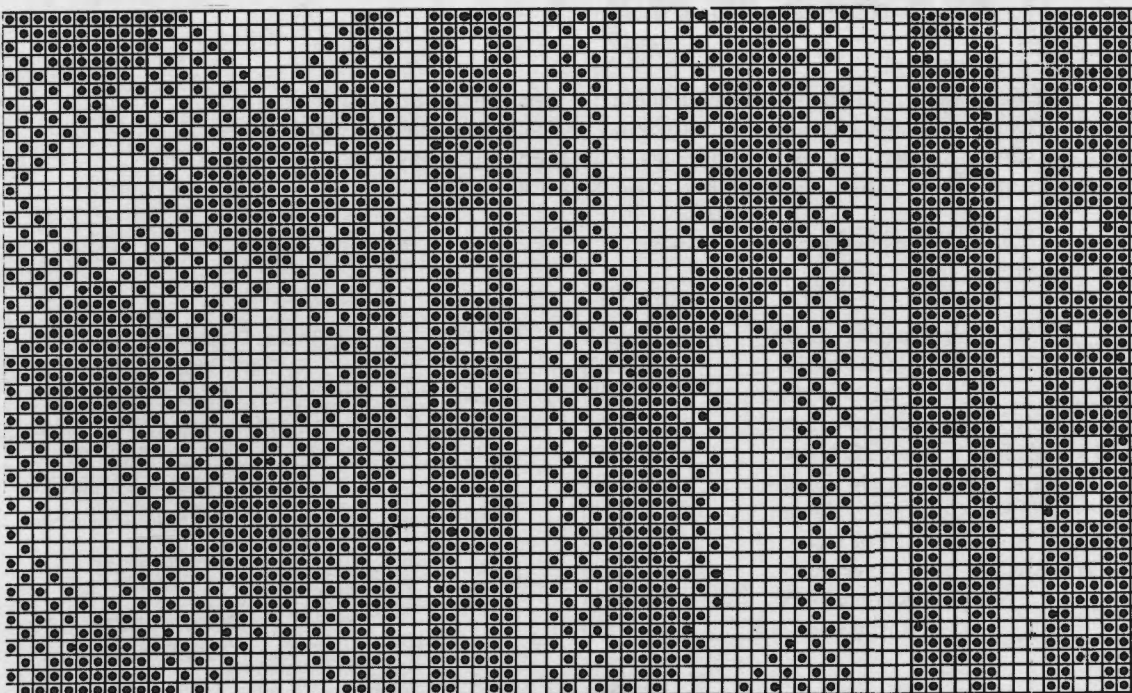
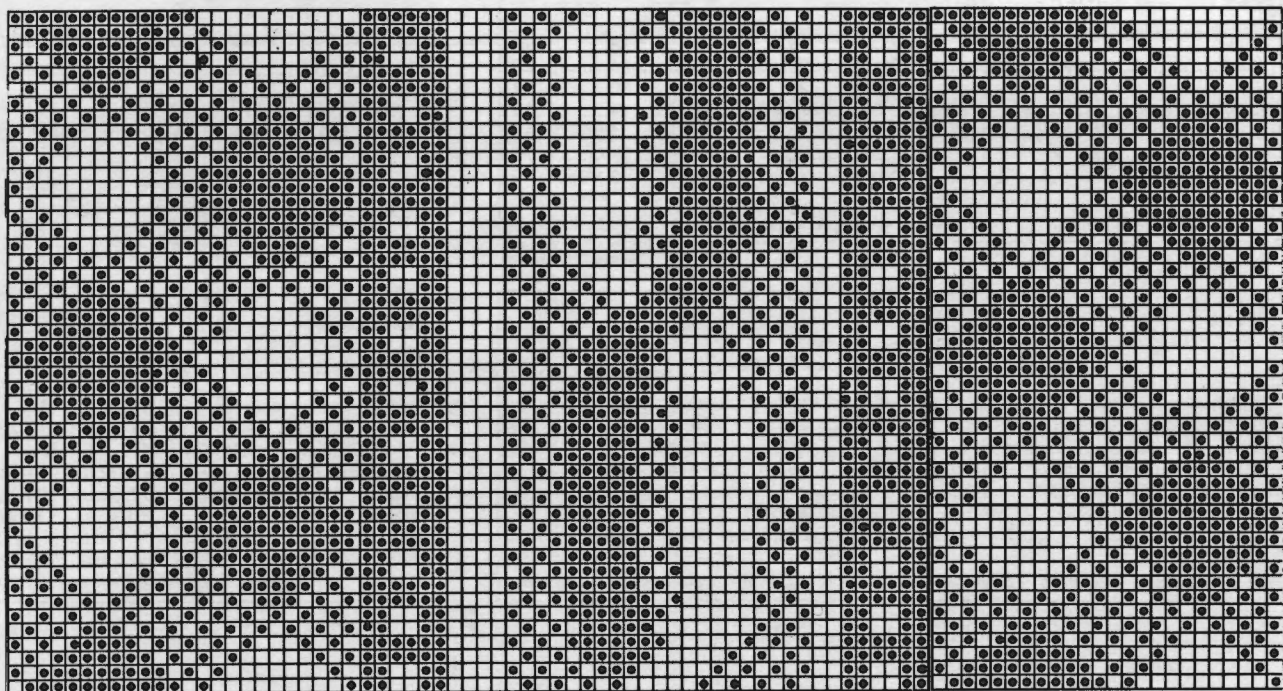

Knitking Sizing Chart

MISSES

Size	6	8	10	12	14	16	18
Bust	30 1/2	31 1/2	32 1/2	34	36	38	40
Waist	22	23	24	25 1/2	27	29	31
Hip	32 1/2	33 1/2	34 1/2	36	38	40	42
Back Waist Length	15 1/2	15 3/4	16	16 1/4	16 1/2	16 3/4	17
Shoulder to Shoulder	13 1/2	13 1/2	14	14 1/2	15	15 1/2	16
Armhole Depth	7	7	7 1/2	7 1/2	7 1/2	8	8
Sleeve Length Under Arm	16 1/2	16 1/2	17 1/2	17 1/2	17 1/2	18	18

These are actual body sizes. Proper ease allowance is necessary as determined by the style.

CHILDREN

Size	12 mo	2 yr	4	6	8	10	12
Chest	19	21	23	25	27	28	30
Waist	19	20	21	22	23	24	25
Hip	20	22	24	26	28	30	32
Back Waist Length	7	8 1/2	9 1/2	10 1/2	12 1/2	14	15
Shoulder to Shoulder	7 1/2	8 1/2	9 1/2	10	11	11 1/2	12
Armhole Depth	3 1/2	4	5 1/2	6	6 1/2	6 1/2	7
Sleeve Length Under Arm	6	7 1/2	9 1/2	10 1/2	12	13 1/2	15

These are actual body sizes. Proper ease allowance is necessary as determined by the style.

Mens

Size	34	36	38	40	42	44
Chest	34	36	38	40	42	44
Waist	30	32	34	36	38	40
Hip	35	37	39	41	43	45
Back Waist Length	15 1/2	15 1/2	16	16 1/4	16 1/4	16 1/4
Shoulder to Shoulder	15 1/2	16	16 1/2	17	17 1/2	18
Armhole Depth	8	8 1/2	9	9 1/2	10	10 1/2
Sleeve Length Under Arm	19	19 1/2	19 1/2	20	20	20 1/2

These are actual body sizes. Proper ease allowance is necessary as determined by the style.

WOMENS

Size	38	40	42	44
Bust	42	44	46	48
Waist	34	36	38	40 1/2
Hip	44	46	48	50
Back Waist Length	17 1/4	17 1/2	17 1/2	17 3/4
Shoulder to Shoulder	16 1/2	17	17 1/2	18
Armhole Depth	8 1/4	8 1/4	8 1/4	8 1/2
Sleeve Length Under Arm	18 1/2	18 1/2	18 1/2	18 1/2

These are actual body sizes. Proper ease allowance is necessary as determined by the style.

IS YOUR ADDRESS CHANGING ?

If so, you can insure the proper handling of this change by following the three suggestions below:

- 1) When advising us of your new address, please also indicate your old address.
- 2) Please provide us with six weeks notice to affect this change.
- 3) PLEASE PRINT ALL INFORMATION LEGIBLY.

yarns by knitking

The finest quality KNITKING yarns are used to create the beautiful fashions found in KNITKING Magazine. Kit prices are located with the instructions for each garment. Each yarn comes in a wide selection of colors. The different types of yarns have been selected to allow for blending, mixing, and contrasting—both color and texture. Color cards are available through KNITKING or an authorized Knitking dealer.

Content and approximate yardage is included in the chart below:

	<i>Yds./Pound</i>	<i>Yds./Pound</i>	
Amore	100% Acrylic (50 gr. ball) 245 yds/ball	Pebble	Boucle Cotton/Acrylic/Rayon 700
Angora	100% Rabbit Hair (10 gr. ball) 33 yds/ball	Primo	100% Mercerized Cotton 2500
Acrylite	2/12 Acrylic 2400	Roma	80% Acrilan/20% Antron 2600
Bulkytime	100% Bulky Orlon with slubs 1500	Rubane	(50 gr ball) 100% Polyamid 1/8" ribbon 82/ball
Caprinae	78% Mohair/13% Wool/9% Nylon 980	Silkie	2-Ply Orlon 2100
Glace	100% Slinky Bright Rayon 2400	Starlite	Acrylic w/Metallic Thread 2400
Ice Cream	54% Cotton/46% Rayon 1700	Venetia	70% Wool/30% Rayon 2400
Kotton	100% Cotton 2200		
Lumiyarn	Thin Metallic Yarn (50 gr. cone) 3500		
Nordic	100% Australian Wool 1650		
Pearlyte	100% Rayon Boucle 2200		

**Complete Set
of
Color Cards:
Only \$15.00**

Now You Can Knit Your Garments in the Wink of an Eye and the Tap of a Foot!

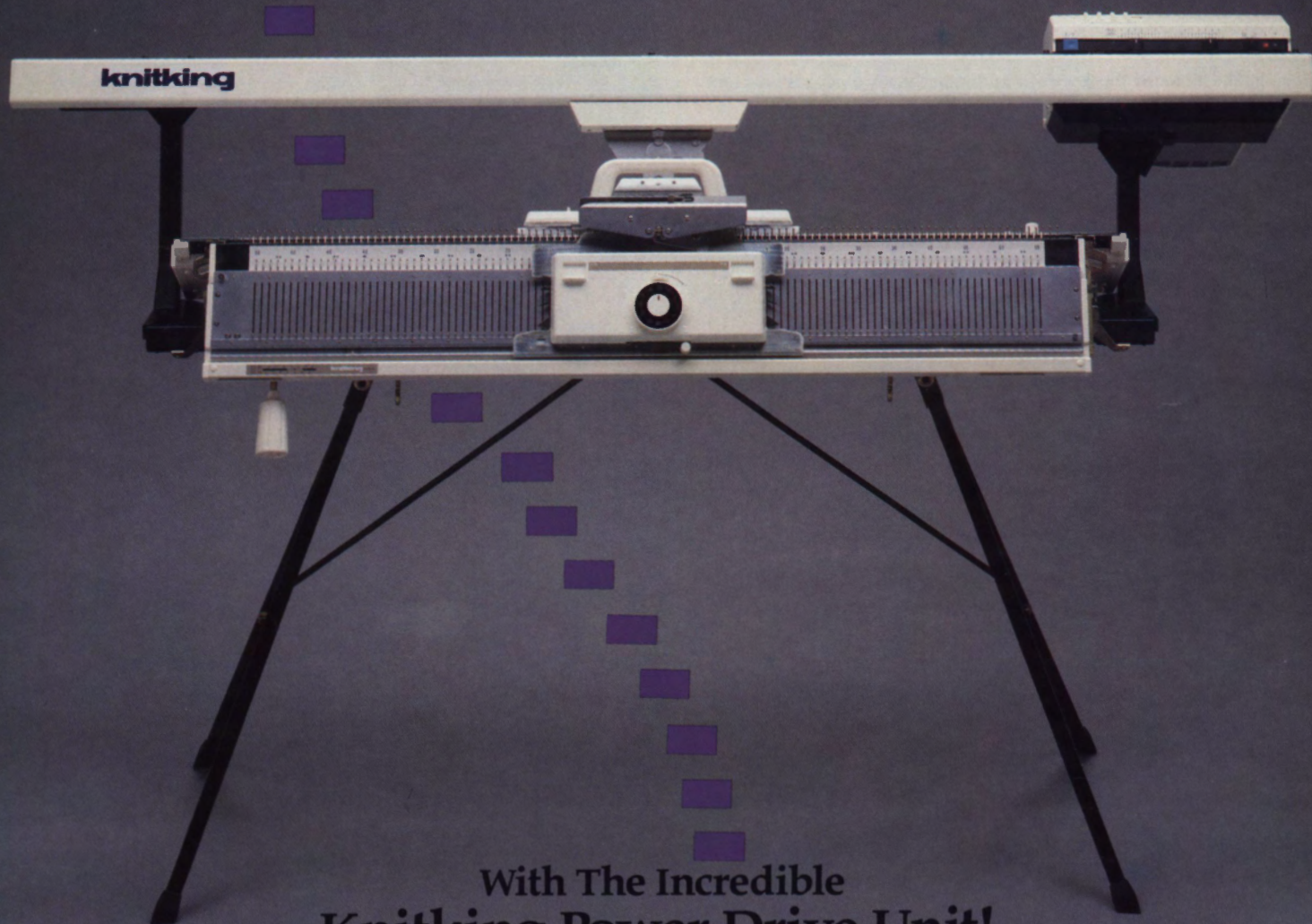

With The Incredible Knitking Power Drive Unit!

It attaches to the carriage of your Knitking knitting machine and, with the push of a button or tap of the foot pedal, automatically moves the carriage back and forth across the knitting bed!

knitking

Where Savings And Value
Are Always In Fashion

1128 Crenshaw Blvd., Los Angeles, CA 90019 213-938-2077

The Unequaled Features of the KNITKING POWER DRIVE UNIT Will Help Make the Ease and Speed of Garment Creation More Incredible Than Ever!

Operates at two speeds to best accommodate your stitch type, and the weight and

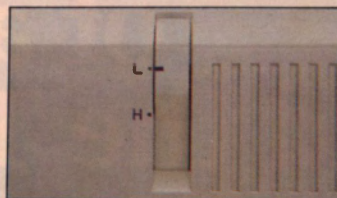

tension of your yarn.

Turn on the motor by the press of a button or the tap of an optional foot



pedal, for continuous or one-row-at-a-time knitting.

Easily control the distance left and right that the carriage



will travel.

It turns itself off automatically

Set the row counter for the number of rows



you want to knit and the PDU will shut off automatically when the preset row number is complete.

Yarn Tension Unit with special

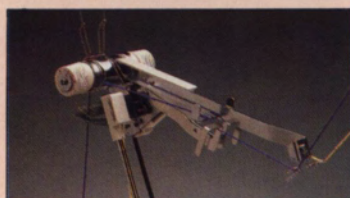

sensors shut off the Unit automatically if the yarn runs out, breaks, or if a knot is detected.

It's complete and versatile

The Knitking Power Drive Unit comes complete with

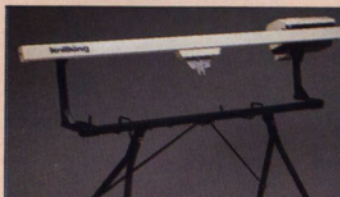

a sturdy, custom designed table-stand.

It can be used with both standard bed and bulky knitting machines



... with no additional parts or attachments!

knitking

1128 Crenshaw Blvd., Los Angeles, CA 90019 213-938-2077

743

Angora / wool blend mixes with Pebble in the versatile, simple Fair Isle Design. The neck insert is knitted in short rows with our angora/wool plated with Roma. An ultra suede cut-out is applied to outline the insert. Knit it on the Punch Card Bulky with Ribber.



▼ Parfait ▼ Perfect ▼



744

A pouf of a Dress worn on the purl side. A scattering of Ribbon appliques make attractive accents. You can knit it on any standard machine with Ice Cream yarn.

▼ Woven ▼ Stripes ▼



745

... add texture and interest to this two piece Dress. The Top is knitted sideways, the Skirt in two sections with a border at the lower edge. Knit it on any standard or electronic machine with weaving capability. Pearlyte is the basic yarn, with Pebble for weaving. The bands are ribbed.

▼ All ▼ Day ▼ Comfort ▼



746

747

. . . begins with a softly fitted sheath Dress knitted with Roma in Stockinette stitch or any standard machine . . . then top it with a woven vest using a variety of coordinated Knitknit textured yarns. Any standard punch card or electronic machine with ribber can be used.

▼ Year ▼ Round ▼ Fashion ▼

748

... to delight anyone, is a two-piece Dress that is knitted in a Tuck and Skip stitch on the Punch Card Bulky machine. A softly tied Collar is the final touch for flattering loveliness. Knit it with our Silkie yarn.

▼ Sweet ▼ And ▼ Sassy ▼

749

... and sure to please a small girl. Knitted entirely with the Garter Carriage, the Dress has a dropped ribbed skirt, the bodice a simple Garter Carriage Design. Knit on any standard or electronic machine with a Garter Carriage. Easy to wash and dry Amore is the yarn.

▼ Ice ▼ Cream ▼

750

... is the name of Knitking's popular yarn used to knit this sideways Pullover. It's a combination of Garter Stitch and stockinette stitch and can be knitted on any standard or electronic machine with a Garter Carriage.



▼ Spring ▼ Into ▼ Summer ▼

751

A lovely one-piece Dress in a Fair Isle Design is the perfect addition to your spring wardrobe. It is very easy to knit on any standard or the electronic machine. Choose your two favorite colors of our Pearlyte yarn. The bands are striped ribbing and the fringed Belt, knitted in Stockinette stitch with needles out of work, can alternate as a neck Tie or Scarf.

▼ Striking ▼

752

. . . to say the least about this outstanding Pullover any man will surely be delighted to wear. An original design created on the KC III Pattern Design Computer for use on the CompuKnit III knitter. The bands are ribbed, the yarn Silkie.

Dual Gauge Knitter

Two Knitting Machines for the Price of One

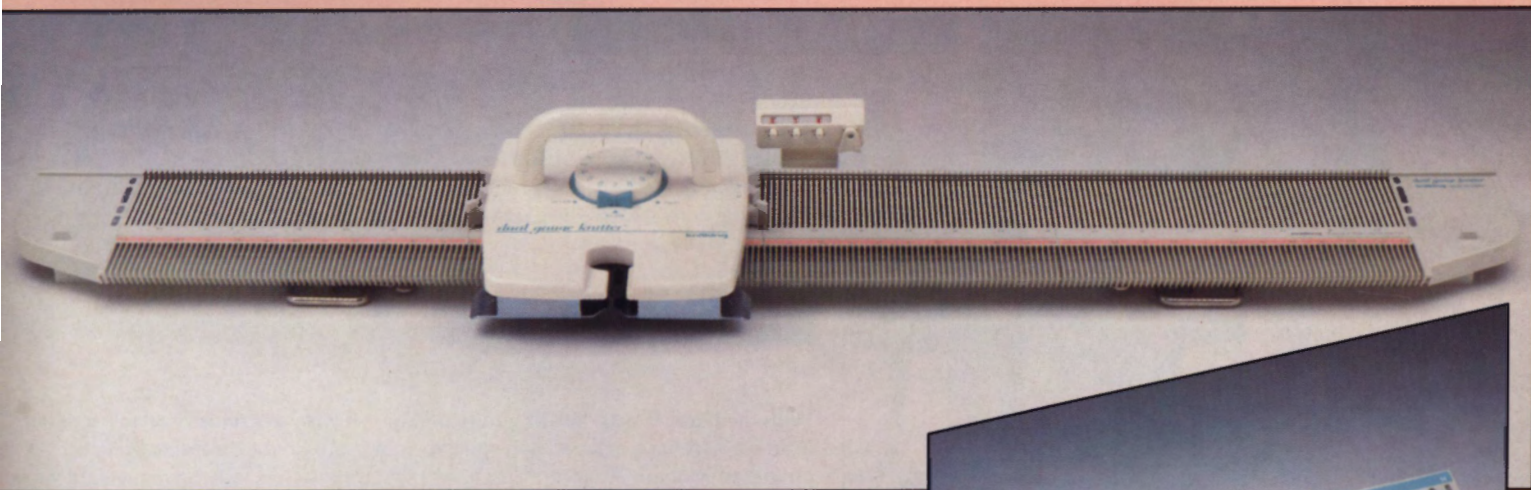

Think of it...one knitting machine that takes the place of two!

As its name implies, this unique knitter offers you the choice between using it as a Standard Bed knitting machine (4.5 mm gauge with 220 needles) or as a Bulky knitting machine (9.0 mm gauge with 110 needles). These two industry-standard gauges are necessary to knit the full range of available yarns...Because of its gauge convertability, **The Dual Gauge Knitter** is the **one** machine that will handle them all!

Pattern capabilities include Stockinette, Skip, Tuck, Holding, Lace, Cabling...and built-in **Intarsia and Plating!!** Fully portable at only 13 lbs., the **Dual Gauge Knitter** also comes complete with Row Counter, Table Clamps, Tools and **Instructional VHS Videotape and Manual.**

The experienced machine knitter will appreciate the wonderful possibilities of Intarsia knitting and Plating on **both** Standard and Bulky beds at a surprisingly **low cost.** The hand knitter or beginning knitter will appreciate the ability to **quickly** knit the **full range of yarns** on one **easy-to-use** machine—the economical **Dual Gauge Knitter!**

The unique features of the **Dual Gauge Knitter** make it **two** truly remarkable knitting machines...in **one!**



The Dual Gauge Knitter's transformation from a Standard Bed machine to a Bulky machine (or vice-versa), is easily accomplished by removing one set of lightweight, color-coded needle plates...and simply replacing them with the other set!

knitking

Where Savings And Value
Are Always In Fashion

1128 Crenshaw Blvd., Los Angeles, CA 90019 213-938-2077

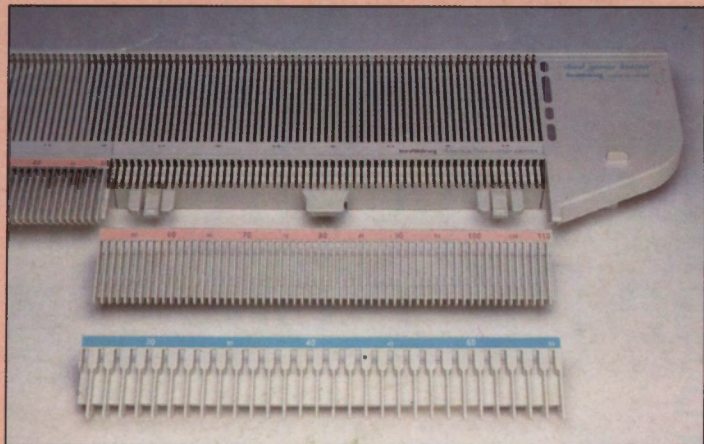

DUAL GAUGE

Just slide out one set of four, lightweight needle plates and replace them with the alternate set of color-coded plates to transform the **Dual Gauge Knitter** from a Standard bed machine (with 220 needles at a 4.5 mm gauge) to a Bulky one (with 110 needles at a 9.0 mm gauge)—the Bulky needle plates prevent every other needle from entering into the knitting position. It's that simple!



TENSION DIAL

Designed for the hand knitter who wants to proceed cautiously into the world of machine knitting, the **Dual Gauge Knitter** features a Tension Dial with numerical settings that actually correspond to hand knitting needle numbers—a tension setting of "10" will provide the same knitting tension as hand knitting with #10 needles, creating that supple hand-knit look!



RANGE OF YARNS

With the **Dual Gauge Knitter**, the full range of yarns becomes available for your knitting—from fine thread and sport-weight Wools and Cottons, to boucles, chunkies, Mohair, Angora, Alpaca, worsted weight, specialty heavy-weight yarns, and everything in between!



INTARSIA DESIGNS

Built-in Intarsia capability extends your artistic freedom to create any Free-Form Design without concern for number of yarn colors. Even the hard-to-create Picture-In-Picture designs are a snap on the **Dual Gauge Knitter**.

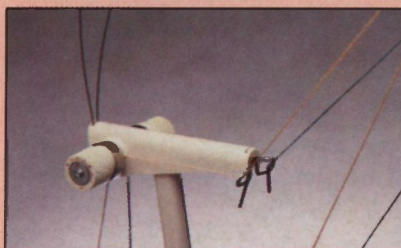

DUAL YARN TENSION

Twin Overhead Yarn Feeders are included—no need to stop and re-thread a different yarn when your knitting calls for a different color or texture!



VIDEO INSTRUCTION

Comes complete with a fully-illustrated Instruction Manual, and a VHS Videotape with visual instructions for machine knitting your first three garments.

knitking

1128 Crenshaw Blvd., Los Angeles, CA 90019 213-938-2077