



## **H**oliday **H**appenings

A perfect selection of lovely knitted garments makes gift giving for all members of your family, easy and fun. You'll enjoy the quick to knit patterns for your special friends, as well.

# 22/4

# Table Of Contents

KNITTING MAGAZINE - VOLUME 22 NO. 4

0000 GENERAL INSTRUCTIONS	12
712 WOMENS MOHAIR AND VENETIA JACKET	13
713 WOMENS CABLE DRESS	14
714 WOMENS 3 PC. SUIT, TOP AND SCARF	16
715 WOMENS SKIP STITCH SUIT	18
716 WOMENS 2 PC. RIPPLE SUIT	21
717 WOMENS HOLIDAY SWEATER	23
718 ANGORA PEPLUM PULLOVER	25
719 WOMENS FAIR ISLE & TUCK BULKY PULLOVER	26
720 MENS BULKY INTARSIA PULLOVER	28
721 WOMENS JUMPSUIT	30
722 WOMENS 3 PC. ENSEMBLE	32
723 MENS FAIRISLE CARDIGAN	35
0000 KNITTING NEWS	36
724 WOMENS BULKY PULLOVER	37
725 MENS BULKY THREAD LACE PULLOVER	38
726 FRINGED PULLOVER	39
727 WOMENS OVERSIZED TOP AND SKIRT	41
728 GIRLS CHRISTMAS TREE SWEATER	42
729 BOYS INTARSIA PULLOVER	43
730 HOLIDAY CRAFT ITEMS	44
731 GIRLS 3 PC. OUTFIT	47

# Editorial

This editorial is truly a two-edged sword. On one hand, it is easy to write because we are filled with tremendous pride as we present our fourth issue for 1988. Another year is behind us and we can look back through Knit-ting's history of outstanding magazines and feel a special sense of excitement over what we feel is one of our finest issues ever. On the other hand, the more somber side of this two-edged sword is the dedication of this last issue of 1988 to the memory of Mike Arm- strong, one of the most talented individuals ever to work at Knitking, who passed away suddenly in late summer this year.

Mike was known to many of you through telephone contact through our technical assistance department. To others, your only contact with Mike came through your enjoyment of the many beautiful and unique creations he fashioned for Knitking magazine. He was an inspiration for knitters. In the relatively short time that Mike had been knitting on machines, he made it his business to not only master every known capability of each machine and accessory, then creatively test the machine to perform techniques and patterns only dreamed about by others!

Some of his most beautiful designs and patterns are found in this issue. Take a special look at #723 one of our favorites because of his clever use of the KCIII Pattern Design Computer in creating this unique houndstooth pattern.

There was a long standing joke in our Design Depart- ment about who "made the cover". Mike many times laughed and said it really didn't matter to him . . . he usually knitted the men's sweaters and he said that he "knew we'd never put a man on the cover." Well, we can happily say that two of his finest are on our cover and that decision was made early and known to him!

To those of you who had the pleasure of meeting or talking with Mike over the years, you'll know exactly what we mean when we say we are dedicating this issue to a genuinely nice human being. The world could use more Mike Armstrong's. He touched our lives and our hearts—for that we can be thankful. We'll miss him.

*Suzanne Str*

# Family Focus

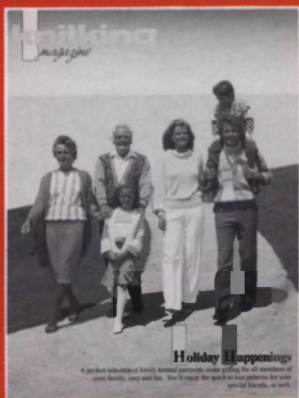

*Garments worn by our "Close Knit Family" are included in this issue of KNITTING MAGAZINE. Three generations step out dressed in great Designer knits, all ready for a day of fun.*

Publisher: KNITTING CORPORATION, 1128 Crenshaw Blvd., Los Angeles, CA 90019. Telephone: (213) 938-2077. Published quarterly. Subscriptions: USA-\$20.00 annually, single copies \$5.50. \$23.00 -all other countries. The entire contents of KNITTING MAGAZINE are copyrighted and must not be reproduced in any shape or form without the express permission, in writing, of the publisher.  
©COPYRIGHT 1988 KNITTING CORPORATION

# Grand Entrance



## 714

. . .to any gala affair. You'll stop the show wearing this striking Suit with matching chic Hat. It is mostly Stockinette stitch with a touch of Fair Isle on the Camisole, then the design becomes bold and bright on the Scarf and sparkles under the veil of the hat. Knit it with Venetia and beautiful Lumiyarn on a standard Punch Card machine.

# Career Bound



## 715

A fashion favorite is a two piece slim Suit to wear everywhere. It is very easy to knit on any standard machine in a Skip (sometimes called Slip) stitch design. Venetia is the yarn.

# Fashion Flash

## 716

Step into this smart two piece suit and travel to all ports of call. The skirt is Stockinette stitch and the Chanel type Jacket a brand new fabulous design that is easier to knit than you think. Knit it on any Bulky machine. . . we guarantee success. The yarn is Starlite.





717

... yourself in this unbelievable Holiday Pullover that makes a fantastic fashion statement. The Compuknit III isolates the Pointsettias and Leaves. The bright knitted ribbon bands tie it all together. Knit it with a beautiful metallic yarn spun especially for KNITKING with Venetia added to the bands.



**P**lush **A**ngora

**718**

...knits up into a Designer's dreamy, feminine Blouse. It's easy and quick to knit in Stockinette stitch on a standard machine. The Peplum is made using short rows. The yarn is an Angora and Wool blend that is absolutely elegant, soft and light in weight. A perfect gift for a special someone, but you will want one as well.

# Glorious Angora

## 719

... Pebble and our Rubane Ribbon Yarn combine for a very different Pullover. The front and back are in Fair Isle and the side panels and sleeve a Tuck stitch. It's knitted on the Punch Card Bulky machine and Ribber.



# 720

A design to entrance and delight any man. . . The Pullover is knitted in sections-part Intarsia and part a Ribbing pattern. The removable Dickey insert is held in place with Velcro. A special purchase yarn, Musarde—a wool and alpaca blend—is hand dyed and subtly shaded and as soft and light as a feather. Knit it on a Bulky machine with Ribbing Attachment.

## Potato Patches

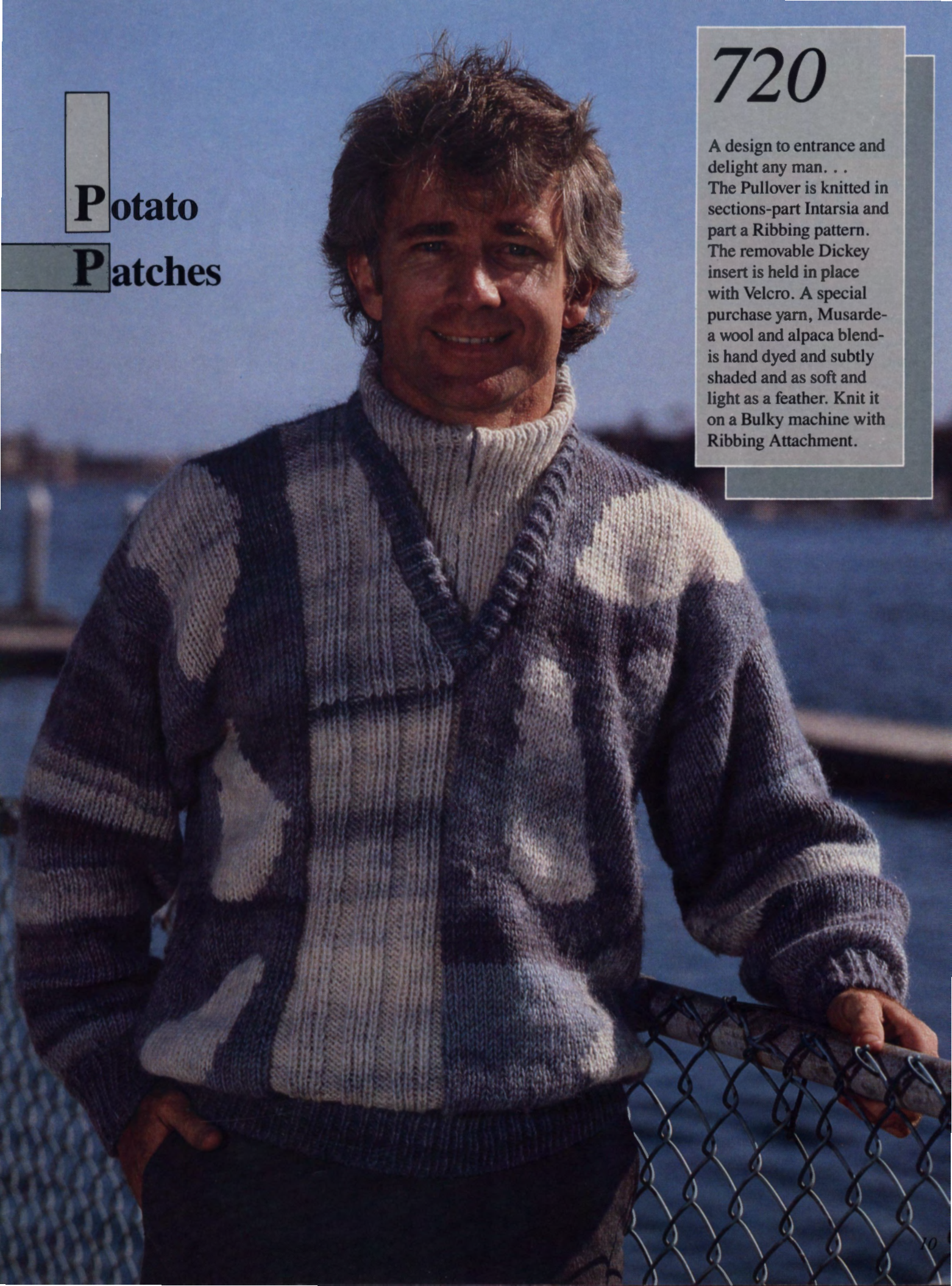

# Gracefully Styled

## 721

...and so easy to wear is a simple to knit jumpsuit with soft tucks at shoulders and a surprise bodice. It's perfect for holiday entertaining at home and you can wear your favorite sparkling jewels and belt. Knit it with Venetia on any standard machine. All Stockinette stitch.



# General Instructions

## THE PRINTED INSTRUCTIONS

Follow the printed instructions or use them in combination with the Charts. When there is any question in the instructions, you have the Charts to show you how the section will look.

Be sure to READ AHEAD so that you KNOW what to do for the size you are knitting. In the shapings, where the number of stitches are the same but the number of times different, you might find shapings like this...3 sts. 1 (2) [3]x - so that for the first size you will bind off 3 sts. 1x, 2nd size 3 sts. 2x, 3rd size 3 sts. 3x. Sometimes the ROWS will be different for each size-so you must watch out for different row numbers.

Shoulder and neck shapings for the back section of a garment usually are shaped at the same time-so ALWAYS WATCH for the words, AT THE SAME TIME.

## HOLDING STITCHES ON THE LEFT SIDE WHILE SHAPING THE RIGHT SIDE

There are different ways to hold stitches on one side while completing the other side. Usually, we tell you to bind off the center sts. for neck and put the left side into holding position while completing the right side. The easiest way, and really the best for beginners, is to take a piece of RAVEL CORD and hand knit the center neck stitches, pulling them back against the needle bed of machine to the "A" or out of work position. The stitches remain in the HOOKS of the needles so you are really only knitting them HALF WAY. With another color of Ravel Cord, knit the remaining sts. on the left side in the SAME WAY.

It is important to protect these held stitches in some way-so you can either hang a REVERSING BAR so that the EYES of the bar go BETWEEN the Gate Pegs on the machine and that the UPPER TIPS of bar only show above the needle bed, OR the simplest way is to use a piece of 1" masking tape and GENTLY place it beneath the knitting-right below the Gate Pegs. DO NOT press the tape, only enough pressure to hold it in place. This will prevent the Carriage (or Slide) from marking the held section.

It is VERY IMPORTANT that you mark the PATTERN ROW where you divide for the split for NECK (or SHOULDER) shaping. If you are using a PUNCH CARD, mark the card-if you are using an ELECTRONIC machine, mark the design window. Also take note of the Row number for the division. When you are ready to work the left section, bring the HELD stitches back to "B" (working) position by pulling each end of the Ravel Cord GENTLY and ripping it off. Be sure to align all needles straight in the "B" or knitting position.

Now you are ready to REFER TO YOUR OWN INSTRUCTION MANUAL for your machine to set the controls to begin knitting the left half. The neck stitches can be bound off after completing the right side, or you can leave them in hold until each side is finished. Bind off or remove them onto contrast waste yarn ready to be picked up for knitting a neckband or for other finishing.

## FULL FASHION DECREASING OR INCREASING

For stockinette stitch, use the Full Fashion method for decreasing or increasing (except for regular cap shaping on sleeves where you decrease the edge stitch). TO DECREASE: Hang the 3rd stitch onto the 2nd stitch, then move the end stitches in to fill the empty needle.

TO INCREASE: Move the 2nd end stitches 1 needle outward, then pick up the 3rd stitch from the row below and hang it onto empty needle.

## PATTERN SYMBOLS

( ) Symbol for 2nd size.

[ ] Symbol for 3rd size.

There are up to 3 sizes given for Patterns in KNITTING MAGAZINE. For example, the Charts and printed instructions will show the cast on as - 124, first size, (132), second size, [140] third size.

⬤ Needles in holding position.

⊗ Needles back into working position

⊖ Needle not used-in out of work position

3x1 The number in the box is the number of Rows between shapings. The

4 3x1 above the box gives the sts., and the number of times to make the decreases (or increases). For example: 3x1 over the box with 4 means- At the given Row number, \*decrease 1 st., knit 4 rows\* and REPEAT from \* to \* 2 times more for a total of 3 times in all. All decreasing (or increasing) WITHOUT ROW NUMBER IN BOX must be made on EVERY 2ND ROW.

## THE SAMPLE SWATCH

Before you knit any garment, you must knit a sample swatch using the yarn you have chosen for your garment. If you do not get the correct Stitch and Row Gauge as given for a Pattern in KNITTING MAGAZINE, try different tensions. If you are using the specified yarn, you should be able to get the correct gauge using a smaller or larger tension. If you are using a different yarn, you may have to make several swatches, but the gauge is very important.

To make a sample swatch, Cast on 60 stitches with waste yarn and knit 6 rows. Mark the tension number for your sample swatch by making holes (you can do this with a Lace Carriage or by hand), 4 transfers for Tension 4, 6 transfers for Tension 6, etc. Knit 6 more rows.

Change to garment yarn and set Counter at 0. Knit 30 rows (in Stockinette stitch or Pattern stitch, according to the garment). With Contrast waste yarn, knit the 10th stitch FROM EACH SIDE by hand. Knit 30 rows. Change to waste yarn and knit 12 rows. Remove the sts. from the machine by pushing the Carriage (or Slide) across without yarn.

Pull and stretch the sample swatch both lengthwise and diagonally from corner to corner, then lengthwise again. Gently block the swatch (KNITTING PRESSING CLOTHS are great for this), or you can allow the sample to rest several hours or even over night so that the stitches can return to their basic form.

THE KNITTING STITCH/ROW GAUGE and STITCH/ROW CALCULATOR can be used to find the NUMBER OF STITCHES or ROWS TO 1". After knitting a sample swatch place the STITCH/ROW GAUGE horizontally with the START LINE on the INSIDE

of LEFT stitch mark on sample. Keep it straight then read the number on the Gauge directly below the inside RIGHT mark on Gauge. This will give you the STITCH GAUGE TO 1". For instance, if the number is 8, then you have 8 stitches to 1". To find the ROWS TO 1", measure from the first row of garment yarn, VERTICALLY to the last row. Read the NUMBER from the LOWER EDGE of GAUGE, same as you did for stitches and if the number should be 14, you have 14 rows to 1".

12 Rows		12 Rows
		30 Rows
60 Rows	10 • 40 STS • 10 ↑ Mark ↑ Mark	30 Rows
12 Rows	○○○○ tension holes	contrast yarn
	60 STS	
	6 Rows	6 Rows

THE STITCH/ROW CALCULATOR will now give you the number of sts. or rows needed for a specific measurement. Line the ARROW to the number 8 (8 sts. to 1"). Should you need 20 inches of stitches, find the number 20 below and right above the 20 the Calculator shows 160 sts. It works the same way for rows using the Row Gauge.

## FINISHING

Gently block all sections-For PULLOVERS, JACKETS, and DRESSES: Join the front to back at shoulders and sides. Sew sleeves together and set in. Hem lower edge and sleeve edges if needed. For a double neckband or armhole band, sew 1 edge to inside and 1 to the outside of neck or armhole. For a single ribbed band, sew 1 edge to the outside of neck or armhole edge. For a cardigan or jacket with buttonholes, finish buttonholes and sew on buttons.

PANTS: Join front to back at sides. Sew inside leg seams, then join to center front and back. Make hem at waistline and inset elastic. Hem lower edge of pant legs.

## ABBREVIATIONS

BO	Bind Off	L.C.	Lace Carriage
Carr.	Carriage	MB	Main Bed
CO	Cast on	Ndfs.	Needles
Col.	Color	Pat.	Pattern
Dec.	Decrease	P	Purl
EON	Every Other Needle	RB	Ribber Bed
FNR	Full Needle Rib	R	Row
G.C.	Garter Carriage	St.	Stitch
G.S.	Garter Stitch	St. st.	Stockinette Stitch
HP	Holding Position	Strnd	Strand
Inc.	Increase	T	Tension
I.C.	Intarsia Carriage	W.Y.	Waste Yarn
K	Knit	WP	Working Position



## WOMANS MOHAIR & VENETIA JACKET

**YARN:** CAPRINAE (Mohair) and Venetia

**SIZES:** Small Medium Large

**AMOUNT:**

Col. 1: Venetia - 2 cones

Col. 2: Caprinae-2 cones

**KIT PRICE:** \$90.00

**TENSION:** 10 Rib. 1/1 II

**GAUGE:** 4.57 sts. 4 rows = 1"

Make on the PC Bulky machine with Ribber. A Fair Isle Design using Punch Card No. 1. Bands are K1, P1 Ribbing.

Caprinae in Feeder A, Venetia in Feeder B.

**BACK:** W.Y. cast on 86 (90) [96] sts. Knit several rows ending with 1 row Ravel Cord to the LEFT. With Venetia in Feeder A, set pattern left to right. Activate card, push in MC and place Caprinae in Feeder A and Venetia in Feeder B. Counter 0. Knit in Pattern to R 44 (48) [52]. Mark each side for setting in sleeves. Continue in Pat. to R 86 (92) [100]. **SHAPE SHOULDERS:** ON EACH SIDE, bind off 10 sts. 2x, 9 sts. 1x. (10 sts. 3x) [11 sts.3x]. After R 92 (98) [108] bind off the remaining sts.

**FRONT:** Make 1, reverse 1. W.Y. cast on 42 (45) [48] sts. same as you did on the back ending with Ravel Cord row to the left. Follow the back instructions for setting up pattern and continue in pattern to R 44 (48) [52]. Mark the left edge for setting in sleeve. Continue in pattern to R 76 (80) [84]. **SHAPE NECK:** Bind off 5 (5) [6] sts. then decrease 1 st. EOR 8x (10x) [12x]. After R 86 (92) [100] **SHAPE SHOULDER** same as the back.

**SIDE PANEL:** Make 2. K1, P1 Rib. With C 1, cast on 28 (30) [32] sts. Knit to R 26. Transfer rib sts. to MB and set in Fair Isle Pat. same as before. Knit to R 70 (74) [78] Divide in the Center. Put ndls. on the left to HP and complete the right side first. \*ON INNER EDGE, decrease 1 st. EVERY ROW 12

(13) [14]x. After R 82 (86) [92] bind off remaining sts. Bring the ndls. on the left to WP, turn Row Counter back to 70 (74)[78] and complete the left half following instructions from \*.

**SLEEVES:** W.Y. cast on 56 (60) [62] sts. same as you did before. After Ravel Cord Row to the LEFT, change to C 1 and set pattern on next row. Counter 0. Knit in Fair Isle Pat. same as before. ON EACH SIDE, increase 1 st. every 6 rows 10 (10) [11]x. After R 60 (66) [68], **SHAPE CAP.** ON EACH SIDE, bind off 4 (5)[6] sts. then decrease 1 st. every 2 rows 15 (15) [16]x then EVERY ROW, 1 st. 6 (8) [9]x. After R 100 (106) [110] bind off the remaining sts.

**SLEEVE CUFFS:** K1, P1 Rib. Bring 32 (34) [38] ndls. on MB to WP. With purl side facing, hang the open sts. of sleeve onto these ndls. decreasing evenly across. With 3 strands C 1, knit 1 row on MB from LEFT TO RIGHT. Transfer every other st. to ribber and knit 25 rows. Knit 1 row with MB Tension 10, Ribber Tension 5. Transfer the rib sts. to MB and BO the crochet method.

**BACK WAISTBAND:** K1, P1 Rib. Bring 76 (80) [86] ndls. on MB to WP. With purl side facing, hang the open sts. of back waist onto these ndls. decreasing evenly across. Transfer every other st. to ribber and with 3 strands C 1, knit 25 rows then knit 1 row with MB Tension 10, Ribber Tension 5. Transfer the rib sts. to MB and BO the crochet method.

**FRONT WAISTBAND:** Make 2. K1, P1 Rib. Bring 40 (42) [44] ndls. on MB to WP. With purl side facing, hang the open sts. of front waist onto these ndls. decreasing evenly across. Transfer every other st. to ribber and with 3 strands C 1, knit 25 rows then 1 row to the right with MB Tension 10, Ribber Tension

5. Transfer the rib sts. to MB and BO the crochet method.

**FRONT BAND:** Make 2. one with buttonholes. **FNR:** With 2 strands C 1, cast on 29 sts. for all sizes. Knit to R 156 (172) [184], making buttonholes on the rows as shown on the Chart and following the instructions as in Practical Knitting Hints, this issue. Make second band without buttonholes.

**COLLAR:** Make 1. **FNR:** With 2 strands C 1, cast on 86(90) [96] sts. Work FNR with changes in tensions as follows: 28 (30) [32] rows T 1.2, 18 (20) [22] rows Tension 1.1, 18 (20) [22] rows Tension 1. Knit 6 rows **CIRCULAR.** Remove on waste yarn.

**CORD TRIM TO COVER OUTSIDE SEAMS:** With 2 strands C 1 and tension 2, cast on 5 sts. Set machine for knitting a cord (push in one part button). **Shoulder:** - knit 46 (50) [54] rows.

**Underarm:** Make 2 - knit 62 (70) [78] rows

**Sleeve:** Make 2 - knit 154 (160) [168] rows.

**Front and Back** - knit 392 (420) [428] rows.

**FINISHING:** Weave all sections together on the purl side. Set in sleeves on the Purl side. Sew front bands in place. Sew on Collar with one side of circular knitting on the inside and one to the outside of neckline then remove waste knitting. Cover all seams with cords, sewing them on carefully.

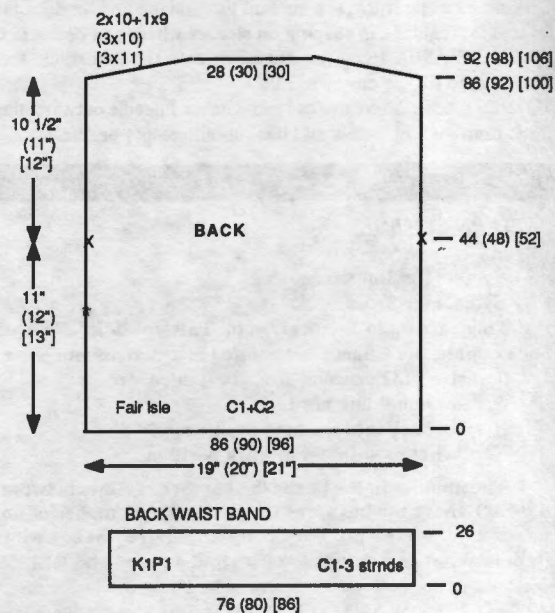
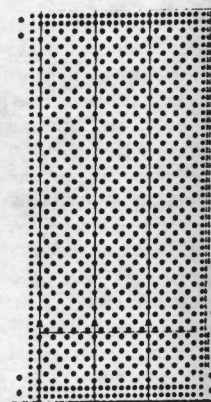
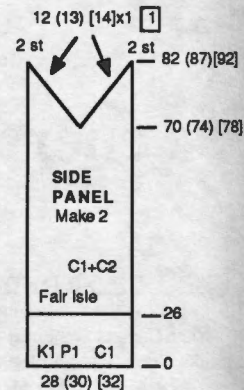

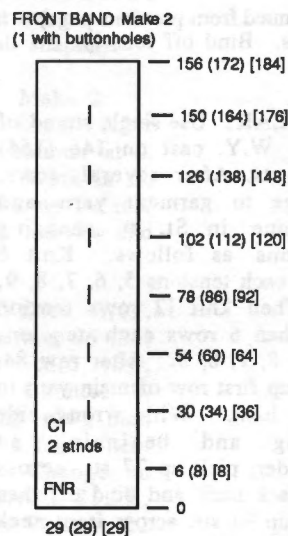
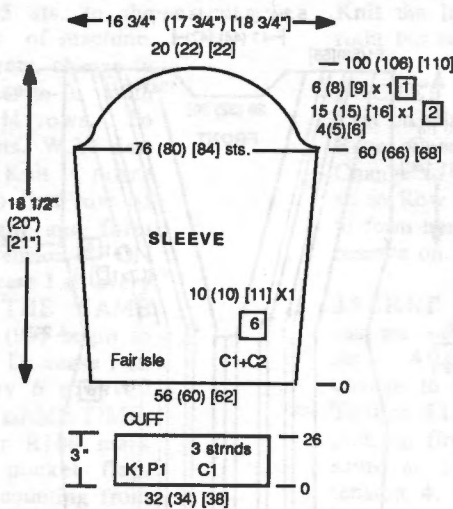
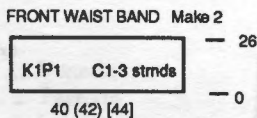
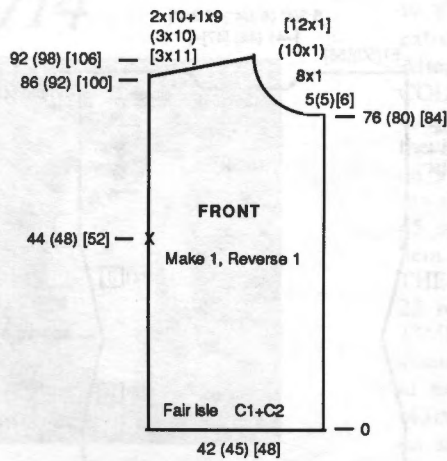

**CORD TRIM FOR OUTSIDE SEAMS** 2 strands C1 at T2  
5 sts. - 1 Part button depressed

1. Shoulder: 6" (6 1/2") [7"] - 46(50)[54] R - Make 2
2. Underarm: 7 1/2" (8") [8 1/2"] - 62 (70) [78] R - Make 2
3. Sleeve: 19" (20") [21"] - 154 (160) [168] R - Make 2
4. Front & Back: 51" (53") [55"] - 392 (420) [428]

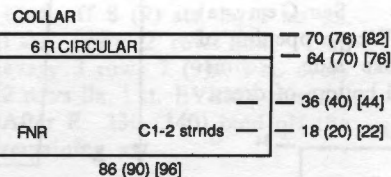

**COLLAR TENSION GUIDE**

- 18 (20) [22] R at T1  
18 (20) [22] R at T1.1  
28 (30) [32] R at T 1.2

# 713



## WOMENS CABLE DRESS

**YARN:** Venetia  
**SIZES:** 8/10 (12/14) [16]  
**AMOUNT:**

40 oz. 44 oz. 48 oz.

**KIT PRICE :**  
\$58.00 \$63.00 \$69.00

**TENSION:** 8 St. st. Rib 7/8  
**GAUGE:** St. st. 14 sts. 19.5 rows = 2" (5 cm) Rib. 15.5 sts. 18.5 rows for Cable Pat. = 2" (5 cm)

Use two strands Venetia with exception of F.N.R. at lower edge of dress and st. st. Collar where you will use one strand.

**BACK:** 'e' cast on 131 (138) [145] sts. and work stockinette st. ON EACH SIDE, increase 1 st. every 30 rows 6x. After R 192 (194) [196] on each side, decrease 1 st. every 10 rows 6x. After R 256 (262) [268] increase 1 st. every 8 rows 6x. After R 308 (314) [320] mark each side for setting in sleeve. After R 400 (410) [420] bind off the center 33 (36) [39] sts for neck, put the sts. on the left into HP

and complete the right side first. \*ON NECK EDGE, decrease 1 st. every 2 rows 4x. After R 410 (420) [430] bind off or remove the sts. on W.Y. Bring the ndls. on the left to WP, turn Row Counter back to 400 (410) [420] and complete the left half. Follow Ins. from \*.

**FRONT:** F.N.R. Cast on 142 (150) [158] sts. After selvedge, knit 4 rows. SET into rib pattern as shown on the chart for transferring needles. On every 6th row, cross the cables as shown on the chart and ON EACH SIDE, increase 1 st. every 26 rows 7x. After R 184, ON EACH SIDE, dec. 1 st. every 9 rows 7x then after R 248, divide in the center and ON EACH SIDE OF 0 move all the sts. of knitter and ribber over to the next outside needle, keeping in pattern. At the same time, ON EACH SIDE, inc. 1 st. every 6 (7) [7] rows 7x. Continue moving sts. over then making cables every 6 rows and after R 294 (298) [302] mark each side for setting in sleeve. Continue

in pattern and after R 362 (372) [382], bind off the center 28 (32) [36] sts. put the sts. on the left into HP and complete the right side first. \*on neck edge dec. 1 st. every 2 rows 13x. After R 388 (398) [408] BO or remove on W.Y. Bring the ndls. on left to WP, turn Row Counter back to 362 (372) [382] Be sure ndls are set in correct Pat. and complete the left half. Follow instructions from \*.

**SLEEVES:** Close both shoulders first. Bring 138 (146) [154] ndls. to WP. With wrong side facing hang front and back onto these ndls. using marked edges as a guide. Set the rib. pattern as shown on chart. ON EACH SIDE, decrease 1 st. every 4 rows 36x. After R 148 (152) [156], remove the sts. on W.Y.

**SLEEVE CUFFS:** K1, P1 Rib. Cast on 49 (53) [57] sts. and work 34 rows K1, P1 Ribbing. Trans. rib sts. to MB. Hang the sleeve sts. held on W.Y. onto these ndls. decreasing evenly (continued next page)

(continued from previous page)  
 across. Bind off loosely.

**COLLAR:** Use single strand of yarn. W.Y. cast on 146 (154) [162] sts. After several rows, change to garment yarn and continue in St. st. changing tensions as follows. Knit 6 rows each tensions 5, 6, 7, 8, 9, 10. Then knit 12 rows tension 10+ then 6 rows each tensions 10, 9, 8, 7, 6, 5. After row 84, pick up first row of main yarn to form hem. With wrong side facing and beginning at shoulder, pick up 77 sts. across the back neck and bind off then pick up 94 sts. across front neck and bind off.

**FINISHING:** See General Instructions. Weave opening of collar and close side seams. Crochet around bottom of dress.

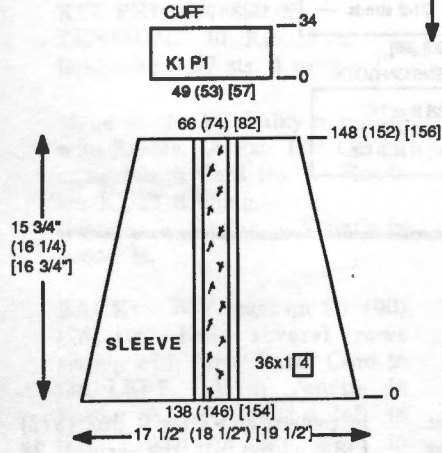
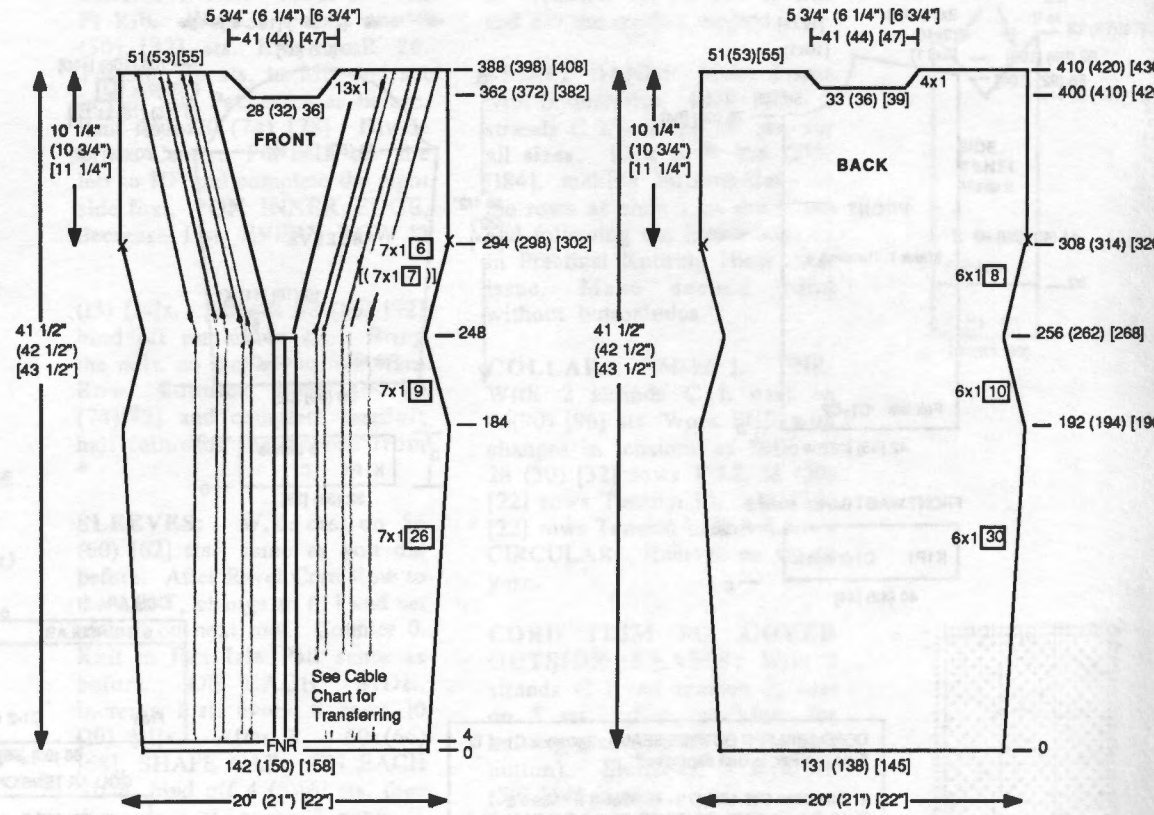

After Perfect Selvedge Follow This Chart for Needle Transferring

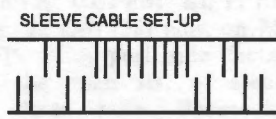

2-Cable Chart Make cables every 6th row

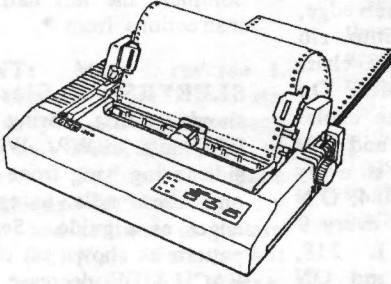
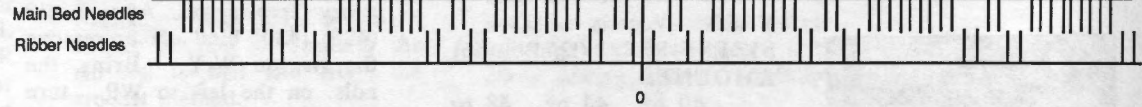
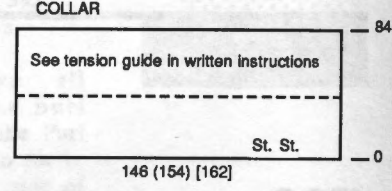
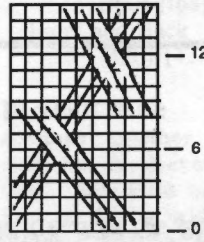

**ONE PICTURE IS WORTH A 1000 WORDS !!**

With the new KNITKING-compatible dot-matrix printer, you can now print out a hard copy of the original patterns you have created using the KC III pattern design computer.

**USE THIS PRINTER TO:**

- Provide a "hard copy" of your unique patterns to share with your friends.
- Provide a template of your patterns to use as a guide for creating your own punch cards for use with your punch card machines.
- Provide a ready pictorial reference of your design creations.

**FEATURES INCLUDE:** • Yarn color change Indicator • Extra large pattern print-out accommodation • Form Feed feature • Uses plain paper or tractor-fed • Includes a unique "Kwik-Konnect" cable for connection to KC III

*By connecting this new printer to your KC III, you too can appreciate the "1000 word value" of having "one picture"...This innovative combination is truly a "match made in heaven," as the opportunities to expand your knitting horizons are now virtually unlimited!!*

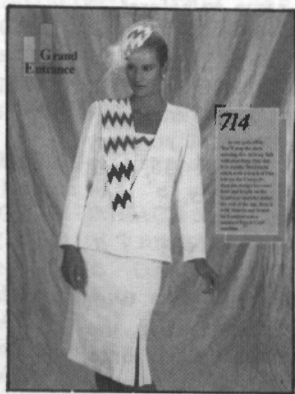

### 3-PC. SUIT, SCARF and HAT

**YARN:** COL. 1: Venetia  
COL. 2: Pearlyte  
COL. 3: Lumiyarn

**SIZES:** 6/8 (10/12)

**AMOUNT:**

COL 1: 2 cones all sizes  
COL 2: 1 cone all sizes  
COL 3: 2 spools all sizes

**KIT PRICE:** \$75.00

**TENSION:** 4 (Venetia)  
4 (Pearlyte)

**GAUGE:** Venetia: 16 sts. 27 rows = 2" (5 cm)

Pearlyte: 14 sts. 24 rows = 2" (5 cm)

**NOTIONS:** Need one button for jacket; and small hat form, comb and veiling for hat.

Make on any standard or Electronic Machine in Stockinette st. with Fair Isle Design on Camisole and Scarf.

**JACKET BACK:** W.Y. cast on 152 (160) sts. Knit several rows ending with 1 row Ravel Cord to the right. Change to COL. 1. Tension 3.1. Counter 0. Knit 28 rows. Pick up first row to form hem. Change to tension 4. ON EACH SIDE decrease 1 st. every 23 rows 4x. Knit to R 236 (242). SHAPE ARMHOLE: ON EACH SIDE, bind off 6 (7) sts. 1x, 1 st. EVERY ROW 4x, 1 st. every 2 rows 3x, 1 st. every 3 rows 3x. After R 332 (344) bind off the center 28 (30) sts. for neck. Put the sts. on the left to HP and complete the right side first. \*SHAPE SHOULDER AND NECK AT THE SAME TIME. For shoulder, bind off 5 sts. 6x, 6 sts. 1x (6 sts. 4x, 7 sts. 2x). For neck, bind off 3 sts. 2x. Bring the ndls. on the left back to WP, turn Row counter back to 332 (344) and complete the left half following instructions from \*.

**JACKET RIGHT FRONT:** W.Y. cast on 45 sts. to the extreme right side of machine. After Ravel Cord row, change to COL. 1 and Counter to 0. With tension 3.1, knit 14 rows. To the left of these sts. W.Y. cast on 96 (102) sts. Knit 14 more rows then pick up first row of 45 sts. on the right and form hem. Change to Tension 4. ON THE RIGHT, decrease 1 st. every 23 rows 4x. AT THE SAME TIME, after R 93 (99) begin to shape front neck. Decrease 1 st. at neck edge every 6 rows 40 (43)x and AT THE SAME TIME, on side edge, after R108 mark 43 sts. for false pocket flap. Begin with ndl. 7 counting from RIGHT/LEFT edge. After R 209 work short rows for bust dart. ON OPPOSITE SIDE OF CARR. put into HP 5 sts. 2x, 6 sts. 5x. All ndls. back to WP and knit to the right. Do not count the bust dart rows so put counter back to 210. After R 236 (242) SHAPE ARMHOLE: Bind off 6 (7) sts. 1x, 1 st. every tow 4x, 1 st. 3 x EOR, 1 st. every 3rd row 3x. After R 332 (344) shape shoulder same as the back.

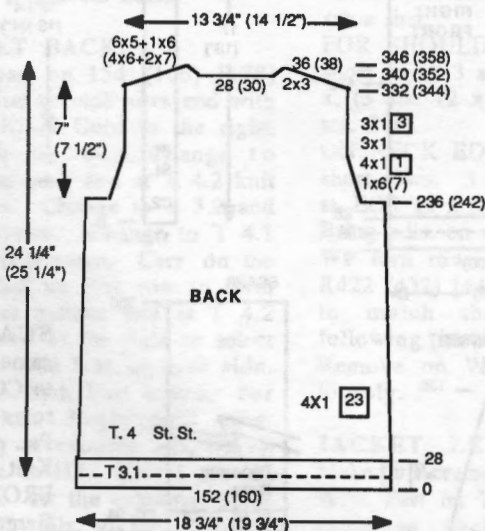
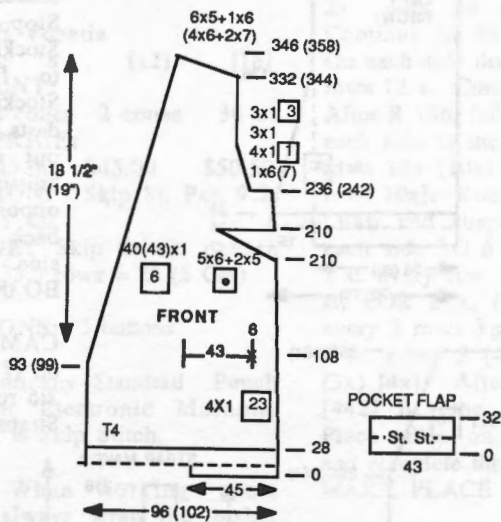

**JACKET LEFT FRONT:** Knit the left front same as the right but reverse all shapings.

**POCKET FLAP:** Make 2. Cast on with W.Y. 43 sts. After Ravel Cord Row, counter at 0. Change to Col. 1. Work in st: st. to Row 32. Pick up 1st row to form hem. Knit one row and remove on W.Y.

**JACKET SLEEVES:** W.Y. cast on same as before, 76 (80) sts. After ravel cord row, change to COL. 1. Counter 0, Tension 3.1. Knit 28 rows then pick up first row to form hem same as before. Change to tension 4. ON EACH SIDE, increase 1 st. every 9 rows 22 (24)x. After row 246 (250) SHAPE CAP: ON EACH SIDE, bind off 8 (9) sts. 1x, 1 sts 5x, 1 sts. every 2 rows 12x, 1 st. every 3 rows 7 (9)x, 1 st. every 2 rows 11x, 1 st. EVERY row 5x. After R 330 (340) bind off the remaining sts.

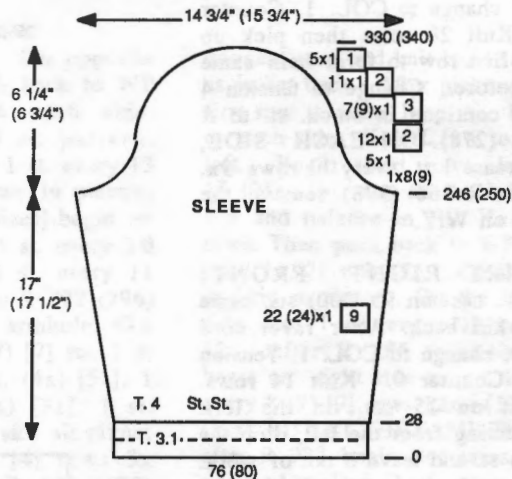

**JACKET FRONT FACING:** Make 1, Reverse 1.

W.Y. cast on 51 (57) sts. same as before. After ravel cord row, change to COL. 1 and counter at 0. Tension 4. Knit to R 92 (98). ON THE LEFT, (right for second section) decrease 1 st. every 6 rows 40 (43)x. After R 341 (353) work short rows. ON opp. side of Carr. put into HP 3 sts. 1x, 4 sts. 2x (4 sts. 1x, 5 sts. 2x). Bring all the ndls. to work, knit 1 row then bind off or remove on W.Y.

**BACK NECK FACING:** Crochet or 'e' cast on 64 (66) sts. Knit 2 rows. On opposite side of Carr. bring 15 ndls. to HP before knitting the next 2 rows. On opposite side of Carr. bring back to WP 2 sts. 5x, 1 st. 5x ON EACH SIDE. After R 22, with wrong side facing, hang the back neck edge of jacket onto these ndls. BO.

(continued next page)

(continued from previous page)

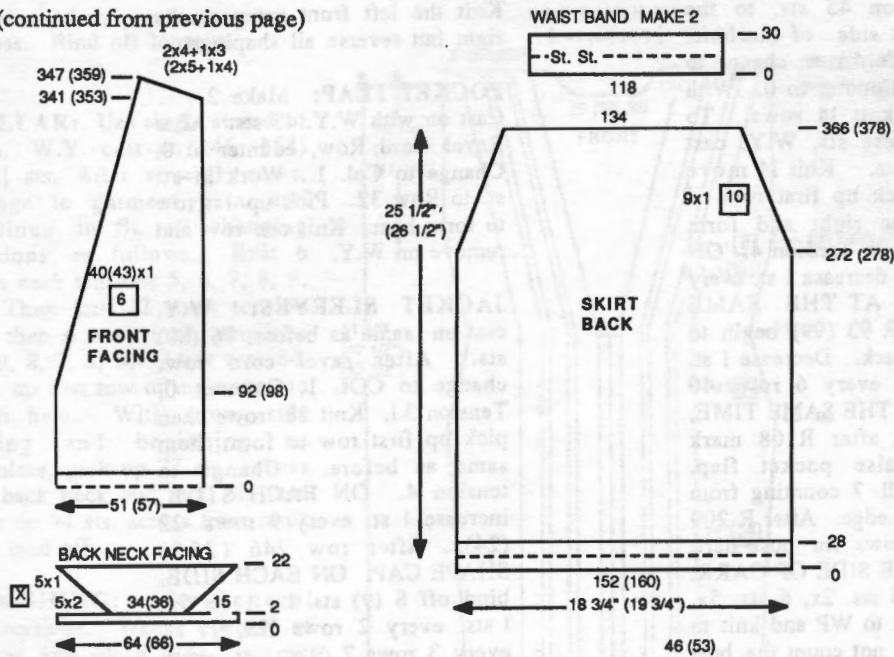

**SKIRT BACK:** W.Y. cast on same as before 152 (160) sts. Tension 3.1. After Ravel cord row change to COL. 1. Counter 0. Knit 28 rows then pick up the first row to form hem same as before. Change to tension 4 and continue in stock. st. to R 272 (278). ON EACH SIDE, decrease 1 st. every 10 rows 9x. After R 366 (378) remove the sts. on W.Y.

**SKIRT RIGHT FRONT:** W.Y. cast on 95 (100) sts. same as skirt back. After ravel cord row, change to COL. 1. Tension 3.1. Counter 0. Knit 14 rows. Cast on 15 sts. on the left. Counting from the left, drop the 15th st. and leave it out of work. Every few rows as you knit, latch that 15th st. up so that it will form a fold later. Knit 14 more rows. Pick up original cast on sts. to form hem. Change to Tension 4. On the left decrease 1st. every 10 rows 13x. After R 258 (264) on the right, decrease 1 st. every 10 rows 9x. After R 352 (364), remove the remaining sts. on W.Y.

**SKIRT LEFT FRONT:** W.Y. cast on 55 (60) sts. After Ravel Cord row, set Counter 0. Knit 14 rows. Cast on 15 sts. on the right. Counting from the right, drop the 15th st. and latch it up the same as for right front. Knit 14 more rows. Change to Tension 4. ON THE RIGHT, decrease 1 st every 10 rows 13x. After R 259 (265), on the left, decrease 1 st. every 10 rows 9x. After R 352 (364), remove the sts. on W.Y.

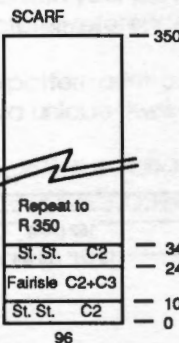
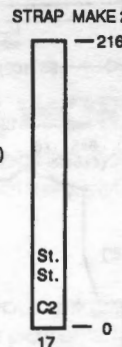
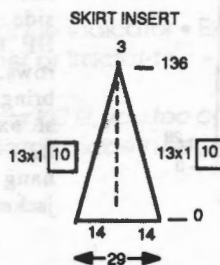
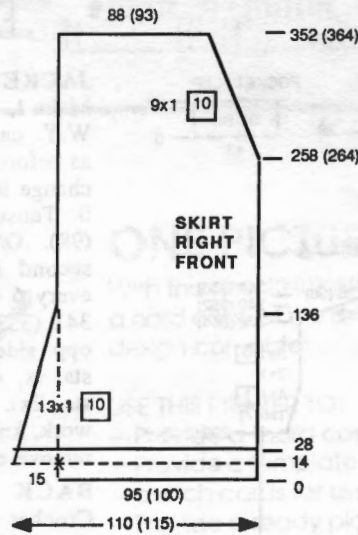
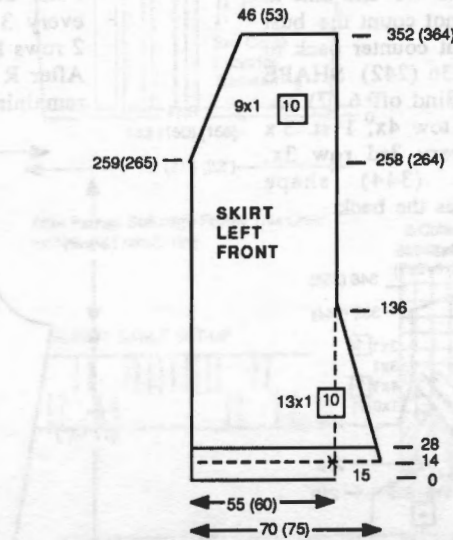

**SKIRT PLEAT INSERT:** W.Y. cast on same as before, 29 sts. After Ravel Cord row, change to COL. 1. Tension 4. Counter 0. Drop the center st. and latch it up as you knit. ON EACH SIDE, decrease 1 st. every 10 rows 13x. After R 136, bind off the remaining 3 sts.

**SKIRT WAISTBAND:** Make 2. Bring 118 ndls. to W.P. With wrong side facing, hang the open sts. of back waist onto these ndls., decreasing evenly across. Knit 30 rows. Pick up first row of band and with yarn threaded in tapestry needle or double eyed tool, loosely go through the doubled sts. binding them off.

**CAMISOLE:** W.Y. cast on 120 (128) sts. Knit several rows ending with 1 row Ravel Cord to the right. Change to COL. 2, Ten. 4. Knit 4 rows Stockinette st. setting Pattern on 4th row. Set machine for Fair Isle and place 2 strands of COL. 3 in B feeder. Knit 24 rows pattern. Stop Pat. and knit 36 rows Stockinette st. Pick up first row to form hem. Continue Stockinette st. After R 76, make darts. On opposite side of Carr. put into HP 36 sts. before knitting the next 2 rows. On opposite side of Carr. bring back to WP 6 sts. 6x. on each side. Continue St. st. to R 214. BO the crochet method.

**CAMISOLE STRAPS:** Cast on 17 sts. with COL. 2 and knit 216 rows St. st. Bind off. Fold Straps in half and sew seam.

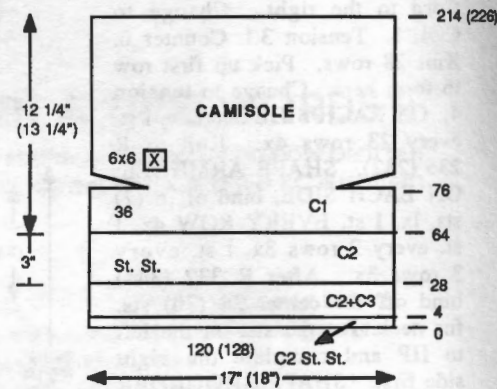

**SCARF:** W.Y. cast on 96 sts. same as you did before. Change to COL. 2. Counter 0. \*Knit 10 rows St. st. setting Fair Isle Pat. on 10th row (WITH COL. 2). Knit 24 rows Pattern.\* REPEAT FROM \* to \* to row 350. Remove on W.Y. Fold Scarf in half and sew seam. Close both ends.



**FINISHING:** See General Instructions. Fold top of Camisole to the right side with soft elastic under fold and sew in place. Sew on straps. Sew false pocket flaps on fronts.

**HAT:** Use 2 strands Venetia and Tension 10. "e" cast on 20 sts. Col. 1. ON EACH SIDE, increase 1 st. every 2 rows 15x, then knit to R 70. ON EACH SIDE decrease 1 st. every 2 rows 15x. After R 112, ON EACH SIDE, increase 1 st. every 2 rows 10x. After R 134, bind off.

**HAT TRIM:** Single strand Col 1 Venetia. T-4. Cast on 30 sts. and work the Fair Isle Design 4x, same pattern as Scarf. Bind off.

**HAT FINISHING:** Press then cover Hat form so that extension piece folds inside front of hat. Use a glue gun or white glue and glue around the edges, but sew the extension to the inside around the edges. Sew a comb in place on the inside. Press trim and press onto Tough Fuse or Wonder Under, cut excess away then press in place (see picture). Tie bow in Veil and attach.

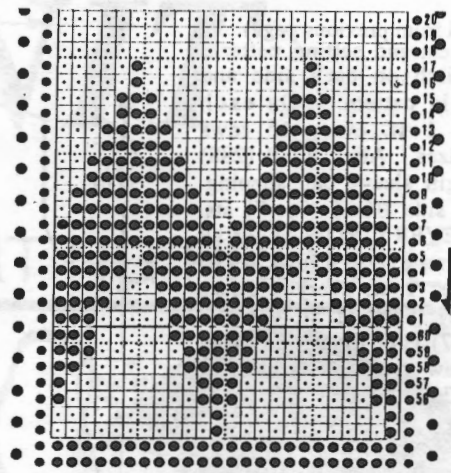

\*Knit 10 rows st. st., 24 rows fairisle pattern. Repeat from \*. (See printed instructions.)

# 715

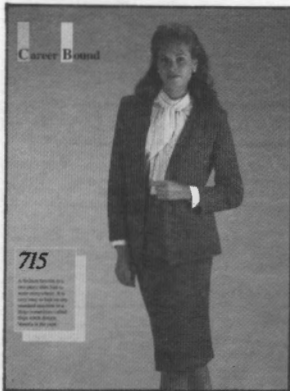

## WOMENS SKIP STITCH SUIT

**YARN:** Venetia  
**SIZES:** 8 (12) [16]  
**AMOUNT:**  
 2 cones 2 cones 36 oz  
**KIT PRICE:**  
 \$45.00 \$45.00 \$50.50  
**TENSION:** Skip St. Pat. 9.2,  
 Bands T 4.2  
**GAUGE:** Skip Stitch pattern  
 11 sts. 35.5 rows = 2" (5 Cm)

**NOTIONS:** 3 buttons

Make on any Standard Punch Card or Electronic Machine. Pattern is Skip Stitch.

**Note:** When working short rows, always wrap the inside needle to prevent holes.

**JACKET BACK:**  
 W.Y. cast on 154 (166) [178] sts. After several rows end with 1 row Ravel Cord to the right. Counter to -0-. Change to Garment yarn and at T 4.2 knit 10 rows. Change to T 3.2 and knit 4 rows. Change to T 4.1 and knit 9 rows. Carr. on the left. Pick up first row to form hem, set pattern and at T 4.2 knit 1 row to the right to select needles. Add 1 st. on each side. Push in both Part buttons for Skip stitch. Begin short rows. Starting at extreme left, bring 63 ndls. to HP. Knit 1 row to the left. At the extreme right bring 63 ndls. to HP. Knit 1

row to the right. On opposite side of carr., push back to WP 21 ndls. 3x on each side. Continue in Skip st. pattern. On each side dec. 1 st. every 13 rows 12 x. Continue in pattern. After R 186, (all sizes) begin on each side to inc. 1 st. every 10 rows 10x (10x) [1 st. every 11 rows 10x]. Knit to R 292 (296) [300] and shape armhole. On each side BO 6 (7) [7] sts. 1 x; 1 st. every row 4x, (4x) [5x]; 1 st. EOR 2 x, (3x) [3x]; 1 st. every 3 rows 3 x for all sizes; 1 st. every 3 (4) [4] rows 3x (3x) [4x]. After R 422 (432) [442] BO the center 20 sts. Place ndlls. on the left to HP and complete the right side first. MARK PLACE IN PATTERN.

\*Shape shoulder and neck at the same time.

**FOR SHOULDER:** BO or use short rows, 3 sts. 10 x, 2 sts. 2 x, (3 sts. 12 x) [3 sts. 10 x, 4 sts. 2 x].

**ON NECK EDGE:** BO or use short rows: 3 (5) [7] sts. 1 x, 1 st. EOR 11 x for all sizes.

Bring ndls. on the left back into WP turn row counter back to R422 (432) [442] and complete to match the right side following instructions from \*. Remove on W.Y. or bind off loosely.

**JACKET LEFT FRONT:** Make 1, Reverse 1.

W.Y. cast on 74 (80) [84] sts. same as back. Change to

garment yarn and knit band same as jacket back. After picking up first row to make hem inc. 1 st. on each side. Knit 1 row to the left. Begin short rows. leave 15 (21) [25] sts. on the left in WP and balance in HP. Knit 2 rows. Then push back to WP 20 ndls. 1x, 21 ndls. 2x. Continue in Skip st. pattern. On the right side dec. 1 st. every 13 rows 12x. After R 186 (all sizes) begin on right side to inc. 1 st. every 8 (9) [9] rows 12x, (12x), [12x]. BUT AT THE SAME TIME after R 233 begin decreases on neck edge. Dec. 1 st. every 10 rows 14x and 1 st. every 9 rows 8 times (1 st. every 10 rows 7 times and 1 stitch every 9 rows 17 times) [1 st. every 9 rows 24 times and 1 st. every 8 rows 2 times] BUT AT THE SAME TIME After R 292 (296) [300] begin armhole shaping. BO 6 (7) [7] sts. 1x; 1 st. every row 4x, (5x) [5x]; 1 st. EOR 3x all sizes; 1 st. every 3 rows 3x all sizes; 1 st. every 3 (3) [4] rows 3 (3) [4]x; and 1 st. every 4 rows 4 times all sizes After R 422 (432) [442] shape shoulder same as back. Remove on W.Y. or bind off loosely.

**SLEEVES:**

W.Y. cast on 76 (82) [88] sts. same as before. After Ravel Cord row change to garment yarn and knit band in st. st. with same tensions as jacket back. At R23, pick up first row (continued next page)

CALCUKNIT  
 of our previous

Order from: your  
 ANGELES, CA 90

and America Express are accepted

(continued from previous page)  
to form hem and setting pattern,  
add 1 stitch on each side and  
continue in pattern. On each  
side inc. 1 st. every 15 rows  
16x all sizes. After R280 (288)  
[296] begin sleeve cap shaping.  
On each side BO 6 (7) [7] sts.  
1x; 1 st. EVERY ROW 5x for all  
sizes, 1 st. every 3 rows 6 (6)  
[10] times; 1 st. every 4 rows  
15x (16x) [11x]; 1 st. every 3  
rows 7 (7) [11] times; and 1 st.  
every row 5 x for all sizes.  
After R 392 (404) [416] BO the  
remaining 22 (24) [24] sts.

**JACKET FRONT BANDS:**  
Make 2, 1 with buttonholes  
St. st.: W.Y. cast on 196 (200)  
[200] sts. After several rows  
end with 1 row Ravel Cord to  
the right. Change to Garment  
yarn and at T 4.2 knit 1 row.  
Change to T 4.1 and knit 5  
rows. Make buttonhole (3 sts.)  
See chart. Knit to R 10. Change  
to T 3.2 and knit 4 rows.  
Change to T 4.2 and knit 4  
rows. Make second row of  
buttonholes over the same  
needles as before. Knit to R 23.  
Pick up first row to form hem  
and remove on W.Y.  
Make second band without  
buttonholes.

**BACK NECKBAND:**  
W.Y. cast on 50 (54) [60] sts.  
same as before. After ravel cord  
row change to garment yarn and  
complete same as front bands.

**SKIRT:** Make 2 the same.  
W.Y. cast on 142 (154) [166]  
sts. After several rows end with  
1 row Ravel Cord to the right.  
Change to Garment yarn and  
knit band with same tension and  
row guide as back jacket band.  
After R 23 pick up first row to  
form hem, add 1 st. on each  
side. Set Skip stitch pattern and  
continue in pattern. On each  
side inc. 1 st. every 71 rows 4x  
for all sizes. Begin at R 362 to  
dec. on each side 1 st. every 20  
rows 6x. After R 468, short row  
20 stitches on each side two  
times. At R 472 change to T  
4.2 and knit waistband with st.  
st. for 24 rows. After R 496  
remove on W.Y.

**FINISHING:**  
See General Instructions.  
Join Bands to front and back  
neck. Set in sleeves. Join side  
seams of skirt. Fold waist band  
to inside and insert elastic.

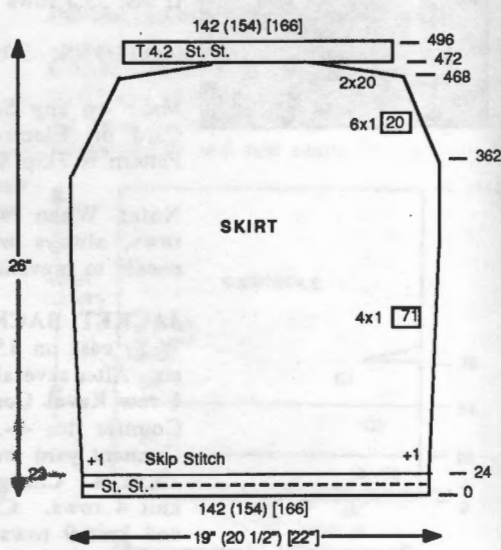
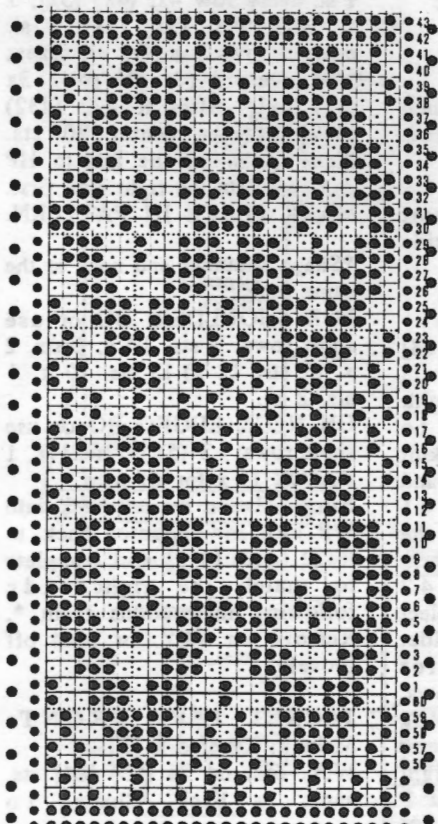
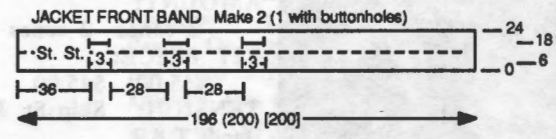
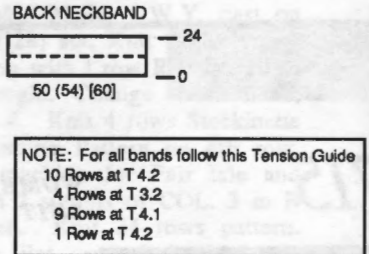
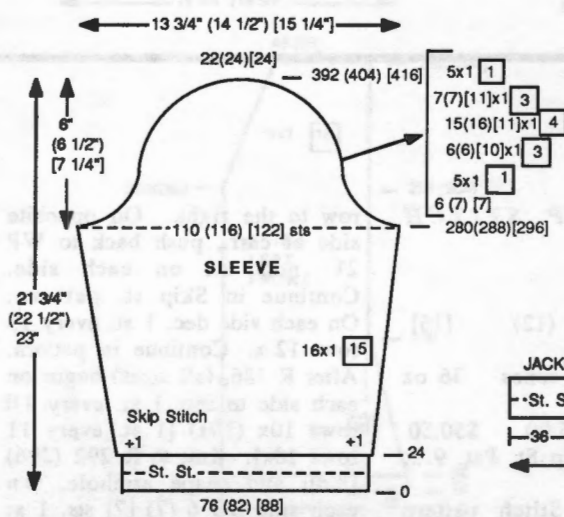
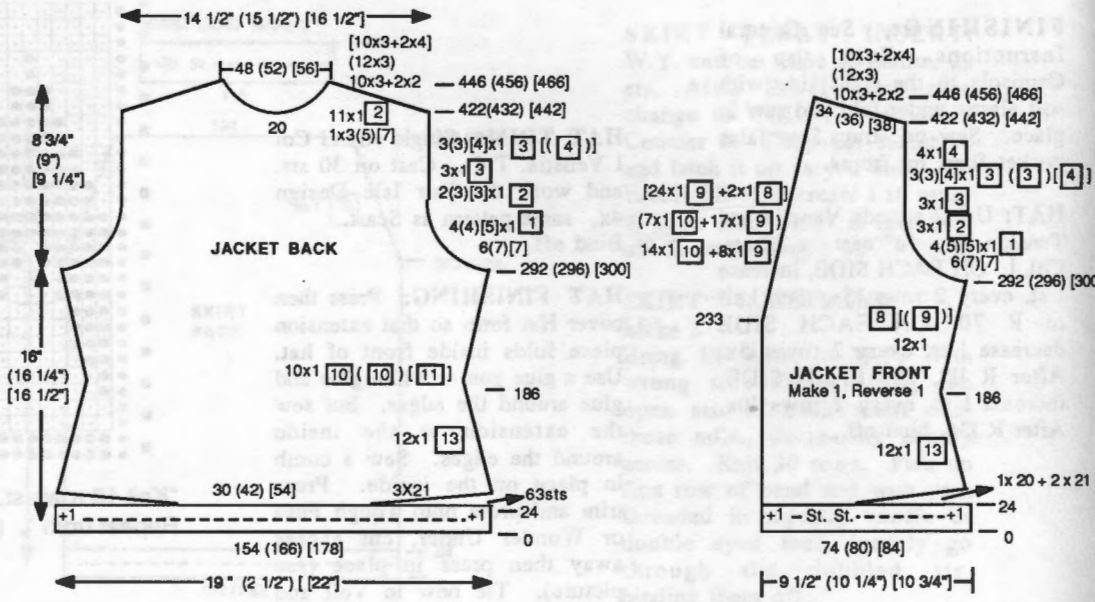

NOTE: For shaping: If no () appear, follow shaping instructions that appear for all sizes. If () appear follow appropriate guide for the size being knitted.

# CALCUKNIT

by **knit**king

## IT SOLVES ALL YOUR CHARTING PROBLEMS

It's purse size  
6 1/2" x 4 1/4" x 3/4"

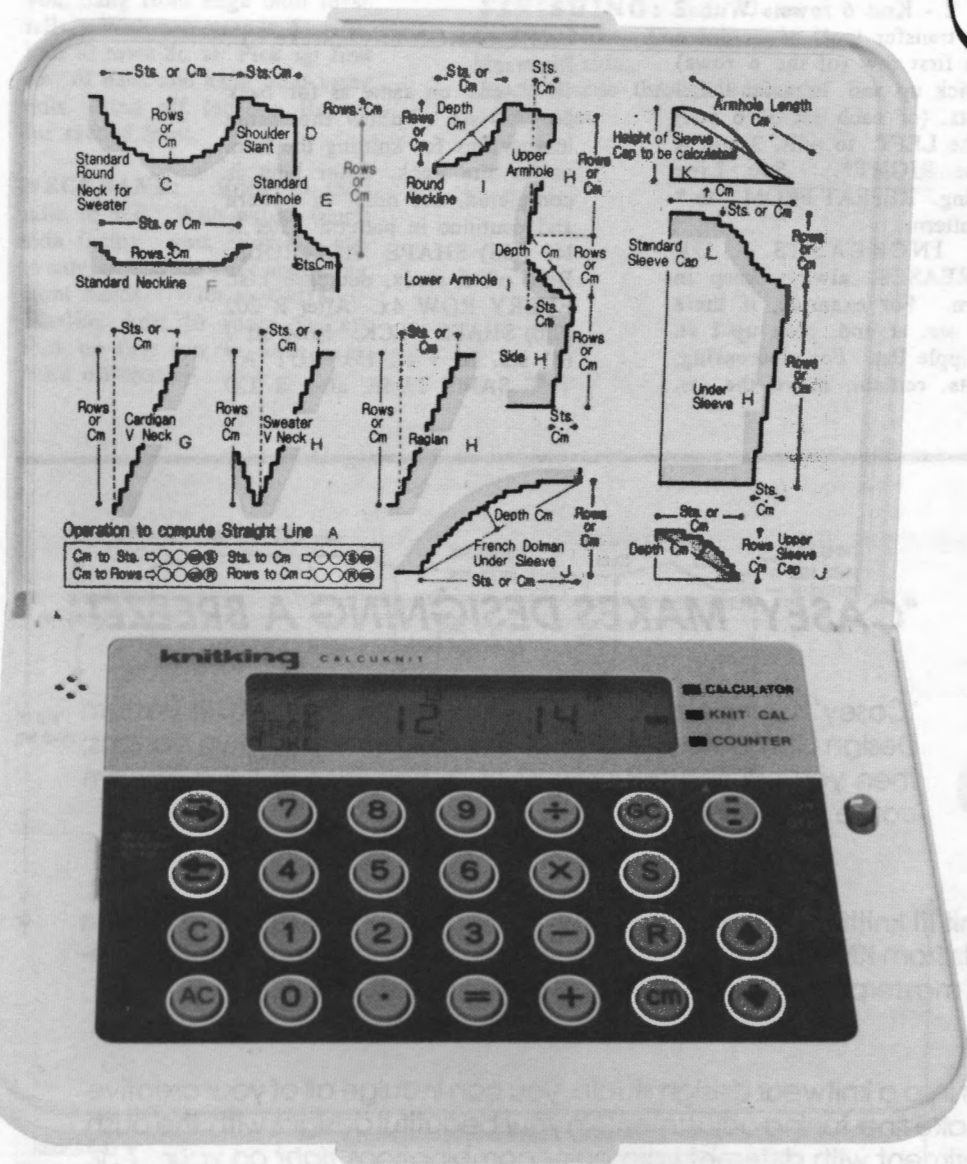

CALCUKNIT takes the time, the tedium, the guesswork and the inaccuracies out of charting both machine and hand knits . . . CALCUKNIT is simple to operate and always accurate.

To chart garments you first make a sample swatch and obtain a correct stitch and row gauge. You then feed them both into the CALCUKNIT . . . Follow by feeding in the garment section measurements . . . The CALCUKNIT then converts your measurements to actual stitches and rows . . . The next step is to feed the garment section by letter (H, for example, is a raglan shape or a V neck). Follow this with the width, in stitches, and the length, in rows, and the CALCUKNIT will give you exact instructions, where to increase, decrease, etc. for your shapings.

CALCUKNIT has three functional settings . . . In the Calculator setting it functions as a standard calculator . . . In the Knit Calculator setting it computes all of your charting . . . In the Counter setting it has a beep alarm: Press a button with each row you knit and the beeper sounds off when you reach the programmed number of rows.

CALCUKNIT operates on two long-life, replaceable lithium batteries.

CALCUKNIT breaks the price barrier for Knitting Computers. It sells for one quarter of the price of our previous low-priced Knit Computer.

Order from your local dealer or direct from KNITTING at 1128 CRENSHAW BLVD., LOS ANGELES, CA 90019. You can order by telephone. Just call 213-938-2077. VISA, MasterCard and American Express are accepted.



### WOMENS 2 PC. RIPPLE SUIT

#### YARN: Starlite

Elastic Thread

Elastic used with yarn for the Stockinette stitch hem of Jacket and Jacket Sleeve hem.

SIZES: 8/10 (12/14)

#### AMOUNT:

Starlite: 38 oz. 40 oz.

Elastic Thread: 1 Spool all sizes

KIT PRICE: \$36.00 \$38.00

TENSION: 6.2 for Jacket. 2 for Skirt

GAUGE: 9.5 sts. 19 rows = 2" (5 cm) for Jacket. 10 sts. 14 rows = 2" (5 cm) in Stockinette st. for Skirt.

Made on the Punch Card Bulky machine. Jacket is a Ripple Pattern. Skirt is Stockinette stitch. Bands are St. st.

**IMPORTANT NOTE: SET UP FOR RIPPLE PATTERN AS FOLLOWS:** Beginning with Ndl. 1 to the right of 0—put this ndl. OUT OF WORK, then working from center out ON EACH SIDE, leave 6 ndls. in work and place 7th ndl. out of work. Continue across the ndl. bed. (See Line Drawing).

**\*STEP 1.** - Knit 6 rows. With 2 prong transfer tool, reach down to the first row (of the 6 rows) and pick up and transfer the 2 end sts. (of each set of 6 sts.) on the RIGHT, to ndls. 3 and 4 on the LEFT.

**STEP 2** - Knit 6 rows. With 2 prong transfer tool, reach down to the first row (of the 6 rows) and pick up and transfer the 2 end sts. (of each set of 6 sts.) on the LEFT to ndls. 3 and 4 on the RIGHT\*. See Line Drawing. REPEAT FROM \* to \* for pattern.

**FOR INCREASES OR DECREASES**, always keep in Pattern. For example, if there are 3 sts. at end, pick up 1 st. for Ripple Pat. For decreasing, if 2 sts. remain, move the sts.

over to fill the ndl. out of work, thus keeping in Ripple Pattern.

**BACK:** W.Y. cast on 92 (98) sts. Knit several rows ending with 1 row ravel cord to the right. Change to TWO STRANDS of Starlite and 1 strand knit in elastic. Counter 0. Knit 10 rows St. st. Pick up first row to form hem. Cut elastic and remove from feeder. SET NDLS. into pattern following Line Drawing. Continue in pattern. After R 148 (152) SHAPE ARMHOLE: ON EACH SIDE, BO 5 sts. 1x, 1 st. EVERY ROW 4x. Knit in pattern to R 228 (238). SHAPE SHOULDER: ON EACH SIDE, BO 6 sts. 2x, 7 sts. 1x (7 sts. 3x). After R 234 (244) BO the remaining neck sts.

**LEFT FRONT:** Make 1, Reverse 1.

W.Y. cast on same as for back 50 (53) sts. Follow the same instructions for knitting the hem as for the back. After hem is completed, set ndls. in pattern and continue in pattern. After R 149 (153) SHAPE ARMHOLE: Bind off 5 sts. 1x, decrease 1 st. EVERY ROW 4x. After R 202 (210) SHAPE NECK: Bind off 7 (8) sts. 1x, 1 st. 15x BUT AT THE SAME TIME, after R 229

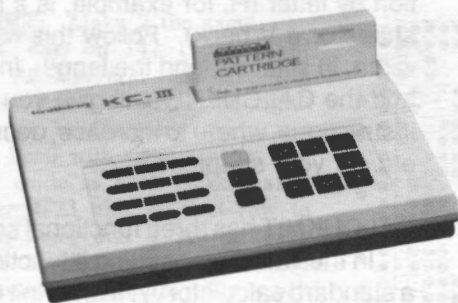

## "CASEY" MAKES DESIGNING A BREEZE!

"Casey" is our nickname for the revolutionary new KCIII Pattern Design Computer. And, if you like to create your own designs, then you will find this newest of accessories to be a "dream come true."

This accessory for your **Compuknit III** knitting machine is not only one of the most recent entries in a long line of innovative products from KNITKING -- It is quite possibly the most versatile tool yet developed for creating the design masterpieces that will truly astound your friends.

By turning your color television set into a knitwear design studio, you can indulge all of your creative fancies, while at the same time make fine-tuning adjustments in your beautiful designs with the push of a button. Then, you can experiment with different yarn color combinations *right on your T.V. screen!*

Casey has been earning rave reviews from knitters all over the country. So, don't hesitate...with Christmas almost here, at \$459.95 the **KCIII** will make the perfect gift for that special knitter you know.

**(239) SHAPE SHOULDER** same as the back.

**SLEEVES:** W.Y. cast on same as you did before. After ravel cord row, change to two strands Starlite, 1 strand knit in elastic. Counter 0. Knit 10 rows St. st. Pick up first row to form hem. Cut and remove elastic. Set the ndls. into pattern same as before and continue in Pattern ON EACH SIDE, increase 1 st. every 9 rows 14 (16)x. After R 148 (154) ON EACH SIDE, bind off 5 sts. 1x, 1 st. every 2 rows 24 (26)x. After R 198 (208) bind off the remaining sts.

**FRONT BANDS:** Make 2. Bring 62 (67) ndls. to WP. With wong (purl) side facing you, hang front edge onto these ndls. With two strands Starlite, knit 10 rows St. st. Pick up first row of band and hang onto same ndls. Bind off loosely. Repeat for second front.

**NECKBAND:** Bring 76 (82) ndls. to WP. With wrong (purl) side facing you, pick up sts. evenly around neckline including front bands. With two strands Starlite, knit 10 rows St. st. Pick up first row to form hem. Bind off loosely.

**SKIRT:** Two strands Starlite. W.Y. cast on 96 (101) sts. same as before. After ravel cord row, change to Starlite. Counter 0. Work Stockinette st. Knit 14 rows. Pick up first row to form hem. ON OPPOSITE SIDE OF CARR. bring to HP, 30 ndls. knit across then bring 30 ndls. opposite Carr. to HP. Knit to the right. Always working opposite Carr. bring back to WP 10 sts. 3x ON EACH SIDE. Be sure to wrap inside ndl. to prevent holes. Knit to R 148. ON EACH SIDE, decrease 1 st. every 8 rows 6x. After R 198 (204) mark the next row and knit 28 rows for waistband. Pick up marked row to form hem. Bind off loosely.

**FINISHING:** See General Instructions. The knit side is the right side. Insert elastic through casing of skirt waist.

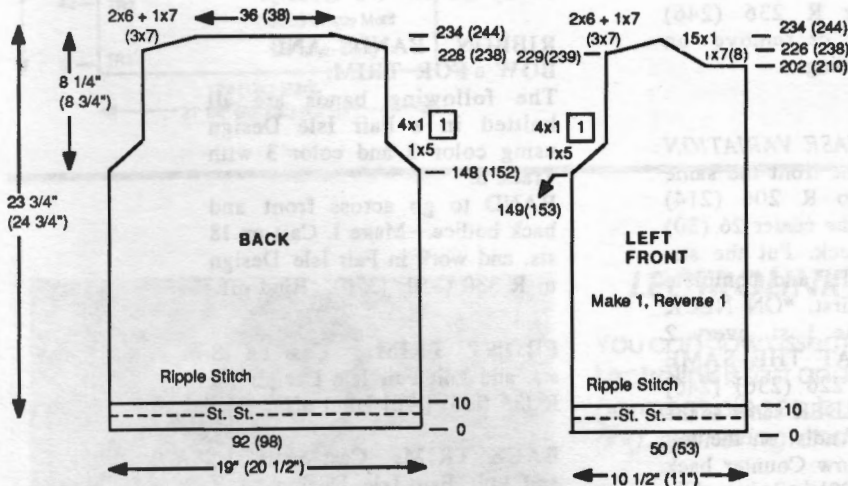
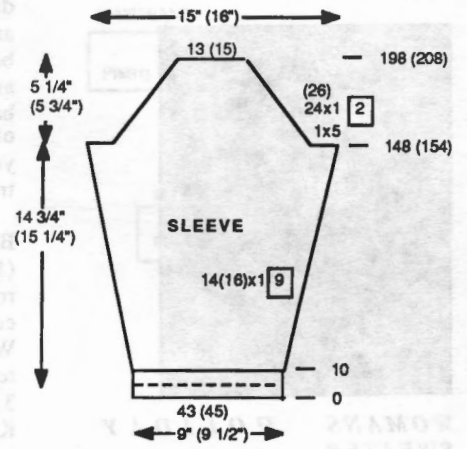

**STEPS FOR CREATING RIPPLE PATTERN**

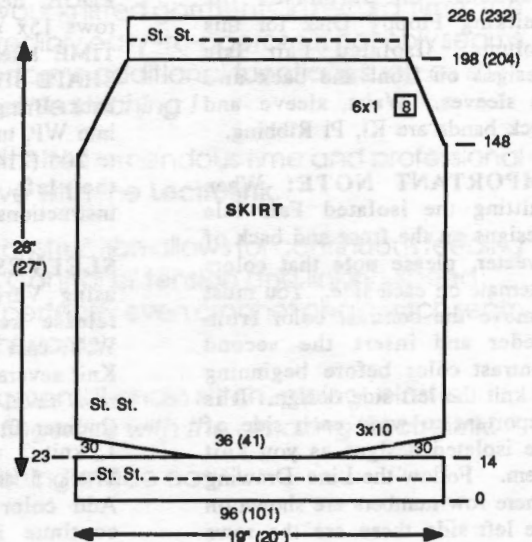
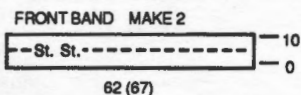
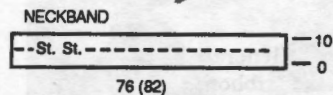
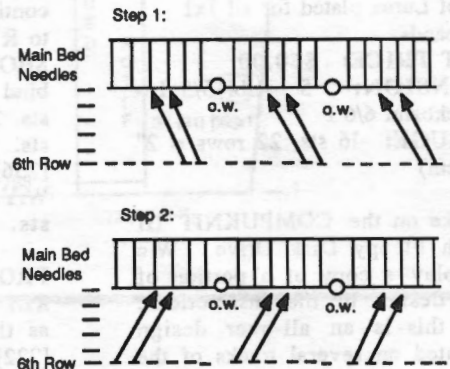



## WOMANS HOLIDAY SWEATER

**SIZES:** 8/10 (12/14) [16]

### YARN:

*Amounts given are for all sizes.*  
**Color 1:** Special Lurex- 2 Cones  
 Always use 2 strands together

**Color 2:** Isabella - Red - 6 balls  
 Use 1 strand

**Color 3:** Venetia - Green - 4 oz.  
 Accent Thread-2 spools  
 Mirage More-1 spool  
 Knit all three yarns together

**Color 4:** Venetia - Beige - 3 oz.  
 Knit together with 2 strands  
 of Lurex plated for all 1x1  
 bands.

**KIT PRICE:** \$60.00

**TENSION:** 5 Rib. 5/5 I -  
 Neckband 6/6 I

**GAUGE:** 16 sts. 22 rows = 2"  
 (5 cm)

Make on the COMPUKNIT III with Floppy Disk Drive. We display a copy of a portion of the design in the instructions. As this is an all-over design located on several tracks of the Floppy Disk, you can use this design as a guide for programming your own locations, or purchase the Knitkng Floppy Disk for this Volume. Isolated Fair Isle Designs on front and back and on sleeves. Waist, sleeve and neck bands are K1, P1 Ribbing.

**IMPORTANT NOTE:** When knitting the isolated Fair Isle Designs on the front and back of sweater, please note that colors alternate on each side. You must remove the contrast color from feeder and insert the second contrast color before beginning to knit the left side design. It is important to wrap each side of the isolated designs as you knit them. Follow the Line Drawing where row numbers are shown on the left side these are the rows

to change track number and color changes. There are 6 different tracks. Tracks 1, 2, 3, and 4 are used for the front and back. Track 5 is for the sleeves and Track 6 is for the ribbon bands. Please watch the left side of the charts where it will tell you when to program a new track.

**BACK:** W.Y. cast on 172 (180) [188] sts. Knit several rows ending with 1 row ravel cord to the right. Counter 0. With color 1, (use 2 strands together throughout) knit to R 3. Program Track 1, Variation Key 1. Knit to the right to set needles, insert color 3 in B Feeder, knit the first motif, change to color 2 in B feeder before knitting the 2nd motif. Continue to R 47. Program Track 2 and knit the two isolated patterns in the same way with color 2, then 3 in B feeder. After R 91, program Track 3 and work in the same way as before. Continue in St. st. with color 1 to R 152 (158) [164]. SHAPE ARMHOLE; but remember to SET TRACK 4 AT R 161. For armhole, ON EACH SIDE, bind off 7 (8) [9] sts. 1x, 4 sts. 1x, 3 sts. 1x, 2 sts 4x, 1 st. 7x. When Pat. is completed, continue in st. st. with color 1 to R 226 (236) [246]. SHAPE SHOULDERS: ON EACH SIDE, bind off 7 sts. 3x, 8 sts. 1x. (8 sts. 3x, 6 sts. 1x) [8 sts. 3x, 7 sts. 1x]. After R 236 (246) [256], bind off or remove on W.Y. the remaining sts.

**FRONT: RELEASE VARIATION KEY 1.** Work the front the same as the back to R 206 (214) [222]. Bind off the center 26 (30) [34] sts. for neck. Put the sts. on the left into HP and complete the right side first. \*ON NECK EDGE, decrease 1 st. every 2 rows 15x and AT THE SAME TIME after R 226 (236) [246] SHAPE SHOULDER same as the back. Bring the ndls. on the left into WP, turn Row Counter back to 206 (214) [222] and complete the left half following instructions from \*.

**SLEEVES:** Knit 1 sleeve using Variation Key 1 then release key for 2nd sleeve. W.Y. cast on 72 (80) [84] sts. Knit several rows ending with 1 row ravel cord to the right. Counter 0. With 2 strands col. 1, knit 3 rows st. st. then set Track 5 and knit to the right. Add color 2 to B feeder and continue in isolated design.

Each time no needles are selected, knit until the next pattern is selected, then change the color in feeder B. AT THE SAME TIME, ON EACH SIDE, increase 1 st. every 5 rows 30 (31) [32]x. After R 158 (164) [170] SHAPE CAP: ON EACH SIDE, bind off 5 sts. 2x, 3 sts. 2x, 2 sts. 3x, 1 st. 17 (19)[21]x, 2 sts. 4x, 3 sts. 2x, 4 sts. 1x. After R 220 (230)[240] bind off the remaining sts.

**NECKBAND.** Make 1. Color 4.

K1, P1 Ribbing. T-6/6 I.

You must insert ribber plating finger. Close 1 shoulder first. Cast on 143 (151) [159] sts. Knit 10 rows. Transfer rib sts. to MB. Pick up sts. around neckline and hang onto these ndls. Bind off loosely.

**CUFFS:** Make 2 Color 4. K1, P1 Ribbing T-5/5 I. Plating same as neckband. Cast on 61 (65) [69] sts. Knit 30 rows. Transfer rib sts. to MB. Pick up open sts. of sleeve and hang onto these ndls. decreasing evenly across. Bind off loosely.

**WAISTBAND:** Make 2. Color 4. K1, P1 Ribbing T 5/5 I. Plating same as before. Cast on 127 (135) [143] sts. Knit 30 rows. Transfer rib sts. to MB. Pick up open sts. of waist and hang onto these ndls. decreasing evenly across. BO loosely.

### RIBBON BANDS AND BOW FOR TRIM.

The following bands are all knitted in a Fair Isle Design using color 2 and color 3 with Track 6.

**BAND** to go across front and back bodice. Make 1. Cast on 18 sts. and work in Fair Isle Design to R 330 (350) [370]. Bind off.

**FRONT TRIM:** Cast on 18 sts. and knit Fair Isle Design to R 156 (166) [176] Bind off.

**BACK TRIM:** Cast on 18 sts. and knit Fair Isle Design to R 166 (176) [186]. Bind off.

**BOW:** Cast on 18 sts. and knit Fair Isle Design to R 180. Bind off.

**FINISHING:** See General Instructions. Sew the ribbon bands in place (See Picture). Make Bow and attach on front.

Single Motif Pattern  
For Complete Pattern,  
Purchase Knitting Magazine Floppy Disk

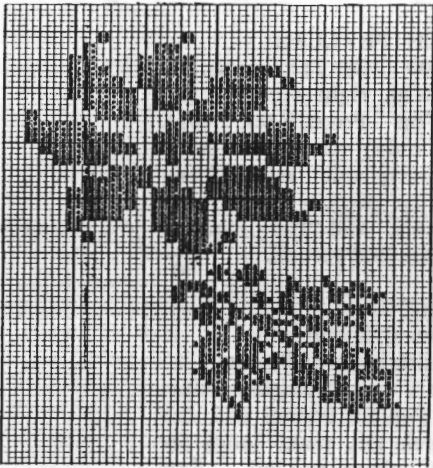

**RIBBON TRIM SECTIONS**  
MAKE FOUR DIFFERENT LENGTHS

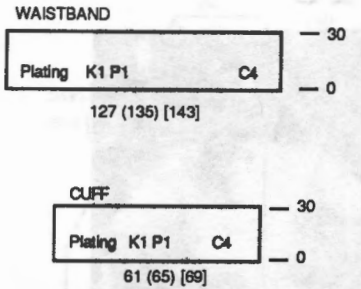
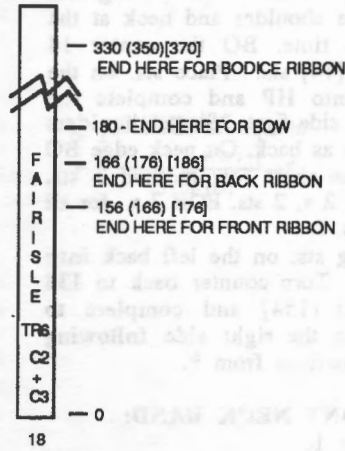

**NECKBAND**

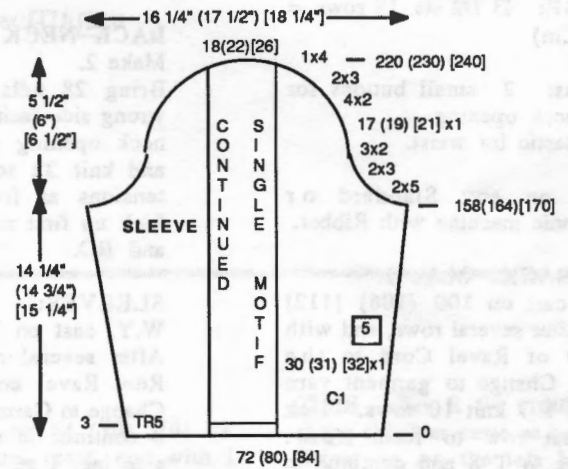
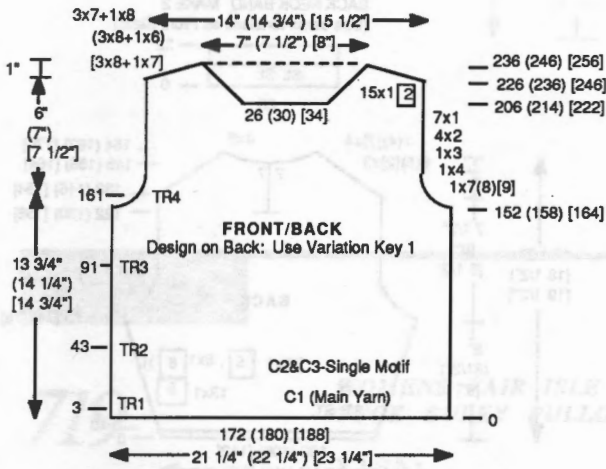

**LECTROLINK + YOU = LINKING MADE EASY**

You can now assemble your knitted garments in record time. The **Lectrolink** is fast and incredibly easy-to-operate. It not only seams garment pieces, but performs additional functions such as *shirring, gathering and creative stitching!*

You will be delighted with the tremendous time and professional look that you will achieve with the **Lectrolink**.

Its 220-needle circular construction allows for continuous feeding of any length garment. Control of tension and linking speed allows you to execute a perfectly even crochet chain stitch seam in fine to medium weight yarns

Finishing, applique, ornamental chain stitch, piping, elastic shirring....*It's all at your fingertips with the amazing Lectrolink.*

It truly is professional finishing made easy!





### ANGORA PEPLUM PULLOVER

**YARN:** Angora/Wool Blend  
**SIZES:** S (M) [L]  
**AMOUNT:**  
 10 oz. 11 oz. 13 oz.  
**KIT PRICE:**  
 \$90.00 \$99.00 \$117.00  
**TENSION:** St. st. T 8  
**GAUGE:** 13 1/2 sts. 18 rows =  
 2" (5 Cm)

**Notions:** 2 small buttons for  
 back neck opening.  
 1/4" elastic for waist.

Make on any Standard or  
 Electronic machine with Ribber.

**TOP BACK:** Make 1.  
 W.Y. cast on 100 (106) [112]  
 sts. After several rows, end with  
 1 row of Ravel Cord to the  
 right. Change to garment yarn  
 and at T 7 knit 10 rows. Pick  
 up first row to form hem.  
 Change to T 8 and continue in  
 st. st. ON EACH SIDE inc. 1 st.  
 every 5 rows 13 x, (1 st. every  
 5 rows 8 x, 1 st. every 6 rows 5  
 x), [1 st. every 5 rows 8 x, 1 st.  
 every 6 rows 5 x]. After R 70  
 (74) [78] shape armhole. On  
 each side bind off 3 sts. 1 x,  
 decrease 1 st. every row 5 x.,  
 all sizes. After R 122 (130)  
 [138] divide in center for back  
 neck opening. Place sts. on the  
 left in HP or remove on W.Y.  
 and complete the right side first.  
 Continue in st. st. to R138  
 (146) [154] and shape shoulder.  
 \*BO or use short row method 3  
 sts. 8 x, 4 sts. 1 x, (3 sts. 5 x,  
 4 sts. 4x) [3 sts. 2 x, 4 sts. 7  
 x]. AT THE SAME TIME after  
 R 148 (156) [164] shape neck.  
 BO or use short row method 7  
 sts. 1 x, then 5 sts. EOR 4 x,  
 (5 sts. EOR 4 x) [4 sts. EOR 5  
 x].\*

Place sts. on the left side into  
 WP. Turn counter back to 138  
 (146) [154] and follow  
 instructions from \* to \*.

**FRONT TOP:** Make 1.  
 Same as Back to R 138 (146)  
 [154]. Omit Neck opening slit.  
 Shape shoulder and neck at the  
 same time. BO the center 14  
 (14) [14] sts. Place sts. on the  
 left into HP and complete the  
 right side first. \*Shape shoulders  
 same as back. On neck edge BO  
 or use short row method 3 sts.  
 EOR 2 x, 2 sts. EOR 7 x for all  
 sizes.

Bring sts. on the left back into  
 WP. Turn counter back to 138  
 (146) [154] and complete to  
 match the right side following  
 instructions from \*.

### FRONT NECK BAND:

Make 1.  
 Bring 54 ndls. to WP. With  
 wrong side facing, hang front  
 neck opening onto these ndls.  
 At T 8, knit 8 rows, at T 7 knit  
 8 rows, at T 8 knit 12 rows.  
 After R 32 pick up first row to  
 form hem and BO.

### BACK NECK BANDS:

Make 2.  
 Bring 28 ndls. to WP. With  
 wrong side facing hang 1/2  
 back neck opening onto these ndls.  
 and knit 32 rows, using same  
 tensions as front neck band.  
 Pick up first row to form hem  
 and BO.

### SLEEVES:

W.Y. cast on 72 (76) [82] sts.  
 After several rows end with 1  
 Row Ravel cord to the right.  
 Change to Garment yarn and at T  
 8 continue in st. st. On each  
 side inc. 1 st. every 4 rows 12  
 x, (1 st. every 5 rows 12 x), [1  
 st. every 5 rows 12 x]. After R  
 58 (62) [66] shape sleeve cap.  
 On each side BO or use short  
 row method 3 sts. 1 x, 1 st.  
 every row 3 x, 1 st. EOR 3 x, 1  
 st. every 4 rows 3 x, 1 st. every  
 row 3 x, 4 sts. EOR 6 x for all  
 sizes. BO the remaining sts.  
 loosely.

### SLEEVE BANDS:

K1/P1 rib: Cast on 73 (75) [77]  
 sts. After selvedge at T 2/2 II  
 knit 10 rows. Transfer ribber  
 sts. to MB and with wrong side  
 facing hang sleeve edge onto  
 these ndls. decreasing when  
 necessary and BO.

### PEPLUM:

Make 1.  
 W.Y. cast on 22 sts. all sizes.  
 After Ravel Cord row, change to  
 Garment yarn and at T 8  
 continue in st. st. On left side  
 inc. 1 st. every 4 rows 24 x, 1  
 st. every 5 rows 36 x. After R  
 320 mark right side with W.Y.

for center. After R 364 begin  
 decreases on the left side. Dec.  
 1 st. every 5 rows 36 x, 1 st.  
 every 4 rows. 24 x. After R 640  
 remove on W.Y.

### ATTACH PEPLUM:

Bring 100 (106) [112] ndls. to  
 WP. With right side facing  
 hang Top Front/Back (one  
 section only) onto these ndls.  
 With wrong side facing hang  
 1/2 of the peplum onto these  
 same ndls. and BO loosely.  
 Repeat for 2nd section.

### FINISHING:

See General Instructions.  
 Weave side seam of Peplum.  
 Crochet 1 row of single crochet  
 around Peplum bottom and also  
 back neck slit, make loops for  
 buttons where needed. Sew  
 buttons in place.

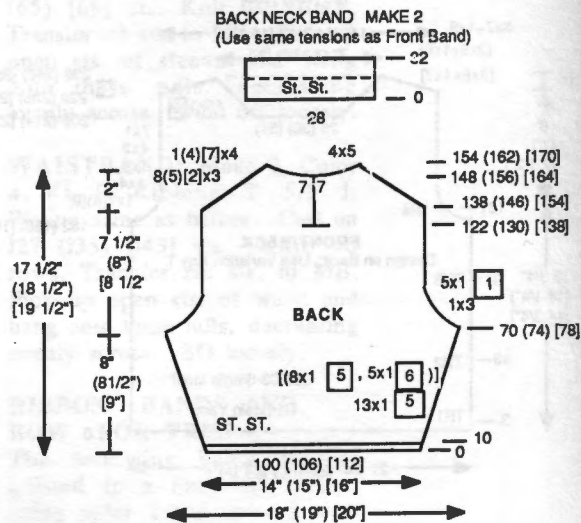



FRONT NECK BAND MAKE 1

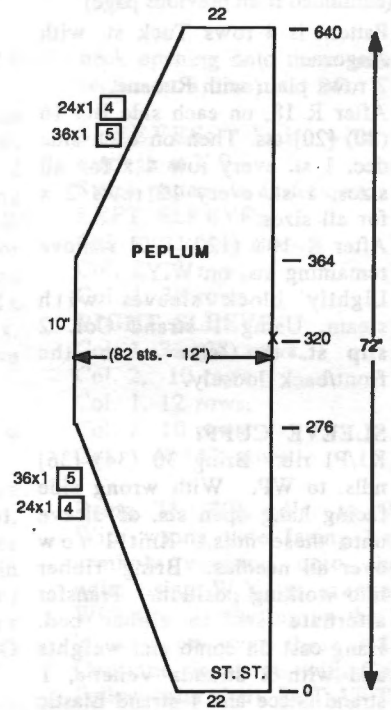
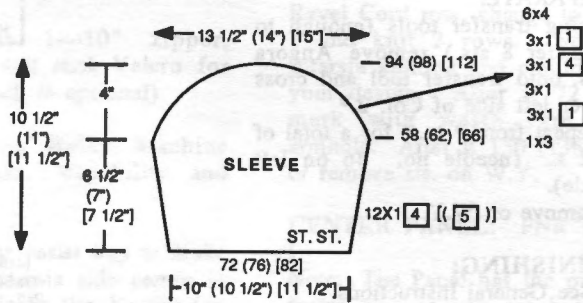
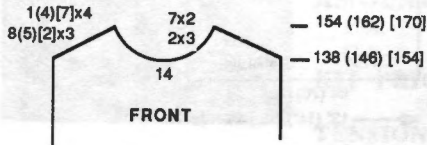
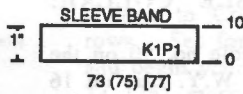

719

WOMENS FAIR ISLE AND TUCK BULKY PULLOVER

YARN:

- Col. 1 Pebble
  - Col. 2 Rubane
  - Col. 3 Angora
  - Col. 4 Venetia
  - Col. 5 Glace
  - Col. 6 Elastic Thread
- SIZES: 6/8 (10/12) [14]  
 AMOUNT:
- |        |         |           |         |
|--------|---------|-----------|---------|
| Col. 1 | 1 cone  | 1 cone    | 1 cone  |
| Col. 2 | 6 balls | 7 balls   | 7 balls |
| Col. 3 |         |           |         |
| Col. 4 | 4 oz.   | 5 oz.     | 6 oz.   |
| Col. 5 | 1 spool | all sizes |         |
| Col. 6 | 1 spool | all sizes |         |

KIT PRICE:

\$124.00 \$133.00 \$135.00  
 TENSION: Body T 6, Sleeve T 10, Rib 1/1 II.  
 GAUGE: Body - 10 sts. 10 R = 2" (5 Cm)  
 Sleeves - 5 sts. 12 1/2 rows = 2" (5 Cm)

Make on the Bulky Punch card machine with Ribber. Intarsia Carriage was used for Outer Neck Band

BACK:

W.Y. cast on 64 (70) [76] sts. After several rows, end with 1 row Ravel Cord to the right. Change to Col. 4 and knit 1 row to the left. Set Pat. 1 (Fairisle Pattern) and knit to the right to select needles. Set card to -Go-. With Col. 2 in feeder -A- and Col. 1 in Feeder -B- continue in pattern. After R 40 mark each side with W.Y. Continue in pattern to R94 (100) [100]. On each side shape shoulder. BO or use the short row method, 5 sts. 2x, 6 sts. 1x; (5 sts. 1x, 6 sts. 2x); [6 sts. 2x, 7sts. 1x]. BO or remove on WY the remaining sts.

FRONT:

Same as Back to R 78 (82) [82]. Shape neck opening. BO the center 14 (16) [18] sts. Place remaining sts. on the left into HP and complete the right side first. MARK PLACE IN PATTERN. On neck edge BO 1 st. EVERY ROW 9x (1 st. EVERY ROW 10x) [1 st. EVERY ROW 10x]. BUT AT THE SAME

TIME after R 94 (100) [100] shape shoulder same as back. Bring sts. on the left back to WP. Turn counter back to R 78 (82) [82]. Return card to correct line in pattern. Select needles and complete the left side to match the right.

INNER NECK BAND:

Make 1. Join one shoulder first. Bring to WP 70 (76) [78]. With wrong side facing hang neck opening onto these needles. With Col. 2 at T 5, knit 9 rows. Change to T 10 knit 1 row and BO. Close 2nd. shoulder.

SIDE PANEL AND SLEEVE:

W.Y. cast on 100 (110) [110] sts. After several rows end with 1 row ravel cord RIGHT to LEFT. Carr. on the left. Set Pat. No. 2 (Tuck st.). Thread Col. 2 into feeder, (allow a long end, at least 3 times the length of machine. This will be used later to slip st. side seams) and at T 10, knit to the right to select ndls. Mark center st. with WY. (continued next page)



(continued from previous page)

Pattern is 4 rows Tuck st. with Angora.

2 rows plain with Rubane.

After R 18, on each side BO 16 (20) [20] sts. Then on each side dec. 1 st. every row 4 x for all sizes, 1 st. every 12 rows 2 x for all sizes.

After R 108 (120)[120] remove remaining sts. on W.Y.

Lightly block sleeves with steam. Using 1 strand Col. 2 slip st. the sleeve to the front/back loosely.

**SLEEVE CUFF:**

K1/P1 rib: Bring 30 (34) [36] ndls. to WP. With wrong side facing hang open sts. of sleeve onto these ndls. Knit 1 row over all needles. Bring ribber into working position. Transfer alternate sts. to ribber bed. Hang cast on comb and weights and with 2 strands Venetia, 1 strand Glace and 1 strand Elastic together at T 1/1 II knit 25 rows. At T 9 on MB and T 4 on ribber knit 1 row. BO.

**WAIST BANDS: Make 2.**

K1/P1 rib: Bring 80 (84) [86]

ndls. to WP. With wrong side facing hang Front or Back onto these ndls. and proceed same as for Cuff.

Knit 34 rows and BO.

**OUTER CABLE COLLAR:**

Make 1.

Starting at needle no. 50 on the extreme right, W.Y. cast on 16 sts. and knit 20 rows. Bring Intarsia Carriage into work and set needles for Intarsia.

Using Col. 3 over 8 sts. and Col. 2 over 8 sts. \*Knit 6 rows. Please remember to cross yarns to avoid separation. Knit 8 rows same color sequence. DO NOT CROSS YARNS SO PIECES SEPARATE.

Using transfer tools (enough to transfer 8 sts.) remove Angora sts. onto transfer tool and cross over left side of Col. 2.\*

Repeat from \* to \* for a total of 12 x. (needle no. 46 on left side).

Remove on W.Y.

**FINISHING:**

See General Instructions.

Weave outer Collar to Inner Neck band.

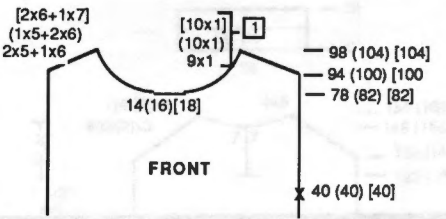
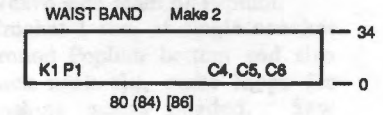
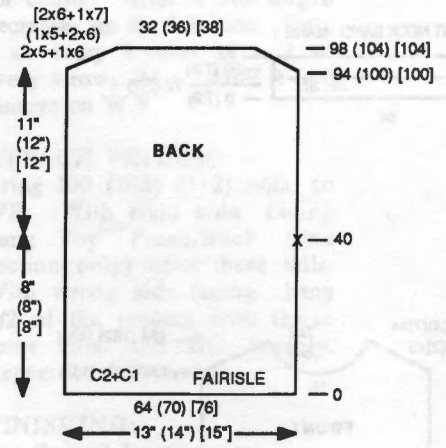

See written instructions for cable collar.

**CUFF**

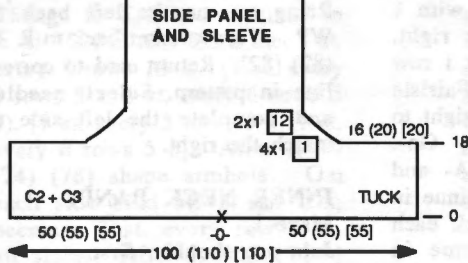
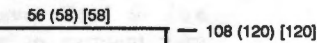
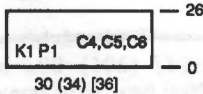

CARD 2: TUCK CARD FOR SLEEVES

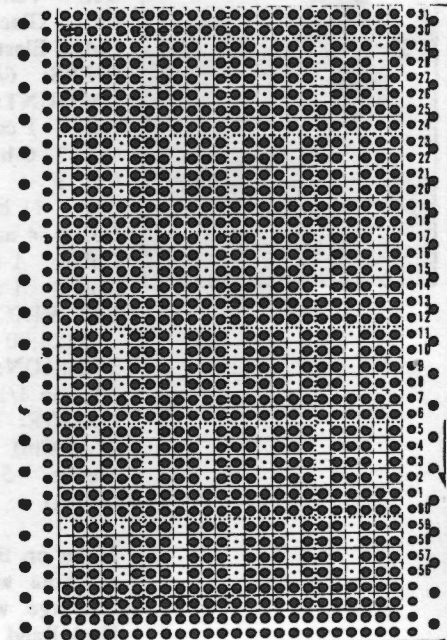

CARD 1: FRONT/BACK FAIR ISLE

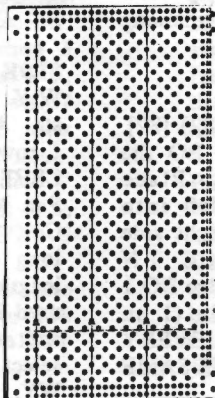



## MENS BULKY INTARSIA SWEATER

**YARN:** Musarde Hand Spun Special Kit Yarn  
55% Wool, 45% Alpaca

Col. 1 Dark Blue, Variegated  
Col. 2 Light Blue Variegated

**SIZES:** 42/44 (46/48)

**AMOUNT:**

Col. 1 11 skeins 12 skeins

Col. 2 4 skeins 5 skeins

**KIT PRICE:**

\$97.50 \$110.50

**TENSION:** See Instructions

**GAUGE:** Intarsia and Back: At T9, 7 sts. 10 1/2 Rows = 2" (5 Cm).

**NOTIONS:** 1—10" zipper, approx. 18" self stick Velcro for Dickie (which is optional)

Make on the Bulky Machine with Intarsia capability and Ribber.

**NOTE:** The easiest way to make the Front Intarsia side panels is to draw them on the Knitleader. Any free form design will do. The Yarn is variegated so it is not important to have a chart for exact placement of the design. Our "Potato" shapes were approx. 3" wide and 7" long but irregular.

The Back was knit the Intarsia method even though there is no design involved. This way the stitch gauge matched the Front. If you prefer to knit with the regular carriage, you will have to make a sample and try to match the stitch gauge for the Intarsia.

**BACK:** Make 1 at T 9.

W.Y. cast on 82 (86) sts. After several rows, end with 1 row Ravel Cord to the right. Change to Col. 1. Knit 2 rows and set for Intarsia knitting. (See note.) After R 72 (76) mark each side with W.Y. for sleeve. After R 124 (130) shape neck opening. BO the center 20 (22) sts. Place the sts. on the left in HP and complete the right side first. \*On neck edge dec. 1 st. EOR 3x. After R 130 (136) BO or remove sts. on W.Y. Bring sts. on the left back into WP. Turn counter back to R 124 (130) and complete to match the right side. Follow instructions from \*

**LEFT FRONT PANEL:** T 9 Intarsia Method

W.Y. cast on 41 (44) sts., same as Back. After Ravel Cord row, change to Col. 1 and knit 2 rows. Set for Intarsia knitting and begin your design. After R 72 (76) mark with W.Y. for armhole. After R 76 (80) on neck edge, dec. 1 st. EOR 1x (2x), 1 st. every 4 rows 13 x. After R 130 (136) BO or remove sts. on W.Y.

**RIGHT FRONT PANEL:** T 9 Intarsia Method

W.Y. cast on 24 (25) sts. After Ravel Cord row, change to Col. 1 and knit 2 rows. Set for Intarsia knitting and continue in your design. After R 72 (76) mark with waste yarn for armhole. After R 130 (136) BO or remove sts. on W.Y.

**CENTER PANEL:** FNR T 4/4 I

Note: The Panel has the pattern facing you as you are knitting, therefore it is necessary to knit according to the drawing, otherwise it will have the shaping on the wrong edge. St. Gauge for FNR - 8 sts. 10 rows = 2" (5 Cm.).

FNR: With Col. 2 cast on 21 (23) sts. After selvedge arrange needles as follows.

On MB leave all needles in WP (B). On Ribber, starting at the left, transfer 3 sts. to MB. Leave the next 3 sts. on ribber, transfer the next 3 ribber sts. to MB etc. across.

Knit to R 84 (88) and mark with W.Y. On right side dec. 1 st. every 4 rows 14 x, 1 st. EOR 1 (2) x. After R 144 (150) transfer Ribber sts. to MB and BO.

**NECK BAND:** Make 1.

**JOIN THE 3 FRONT PANELS TOGETHER.**

**CLOSE BOTH SHOULDERS.**

K1/P1 rib: With Col. 1 cast on 97 (101) sts. After selvedge, ON EACH SIDE dec. 1 st. every other row 7 x, then inc. 1 st. EOR 7x. Pick up first row to form hem. Transfer Ribber sts. to Main Bed. Knit 1 row over all ndls. Either remove on W.Y. or with wrong side facing hang

neck opening onto these ndls. (a section at a time) and BO.

**SLEEVES:** Knit with K-carriage at T 9.

Stripe pattern is as follows:

**LEFT SLEEVE:**

Col. 1, 42 (44) rows.

Col. 2, 18 rows.

Col. 1, 38 rows.

**RIGHT SLEEVE:**

Col. 1, 26 (28) rows.

Col. 2, 10 rows

Col. 1, 12 rows.

Col. 2 10 rows.

Col. 1 40 (42) rows.

Bring 76 (80) ndls. to WP. With wrong side facing hang armhole opening onto these ndls. using W.Y. as markers. With Col. 1, starting on the left 'e' cast on over these ndls. Continue in st. st. with Col.1. Follow color chart, BUT AT THE SAME TIME ON EACH SIDE, Dec. 1 st. every 6 rows 16 x. After R 98 (102) Remove on W.Y.

**WAIST BANDS:** Make 2 at T 3/3 II.

K1/P1 rib: With Col. 1 cast on 73 (77) sts. After selvedge, knit 20 rows. Transfer ribber sts. to MB and with wrong side facing hang open sts. of Front/Back onto these ndls., decreasing evenly across and BO.

**SLEEVE CUFFS:** T 3/3 II

K1/P1 rib: With Col. 1 cast on 35 (39) sts. After selvedge knit 18 rows. Transfer ribber sts. to MB. With wrong side facing hang open sts. of sleeve onto these ndls. decreasing evenly across and BO.

**DICKIE:** (Optional)

Make 1, Reverse 1. T 3/3 II K1/P1 rib: With Color 2 CO 47 sts. After selvedge knit 12 (13) rows. On left (right for other side) BO 21 sts. then dec. 1 st. every 3 rows 2 x, 1 st. EOR 22 x, 1 st. every row 2 x. After R 64 bind off any remaining sts. Join the two pieces at center back. Sew in zipper to front opening.

We used 3" x 1/2" self adhesive Velcro to anchor the Dickie insert temporarily into 'V neck.

(continued next page)

(continued from previous page)

**FINISHING:**

See General Instructions.  
Sew side seams.

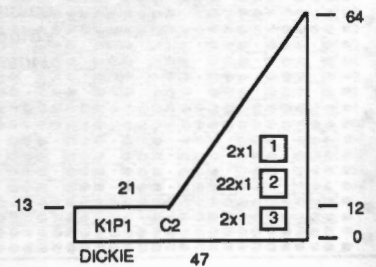
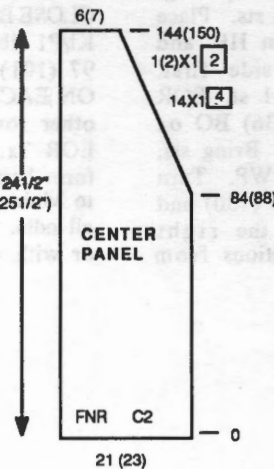
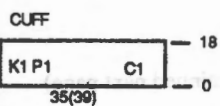
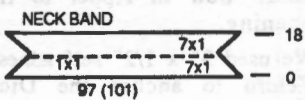
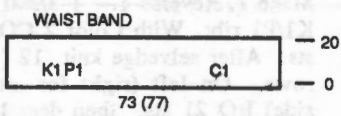
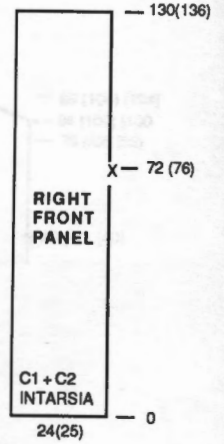
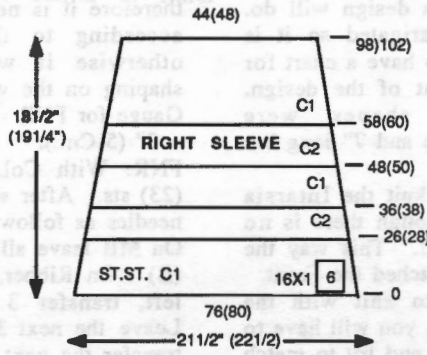
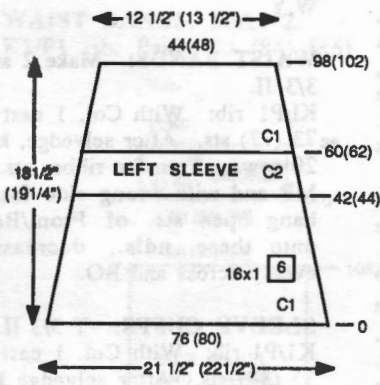
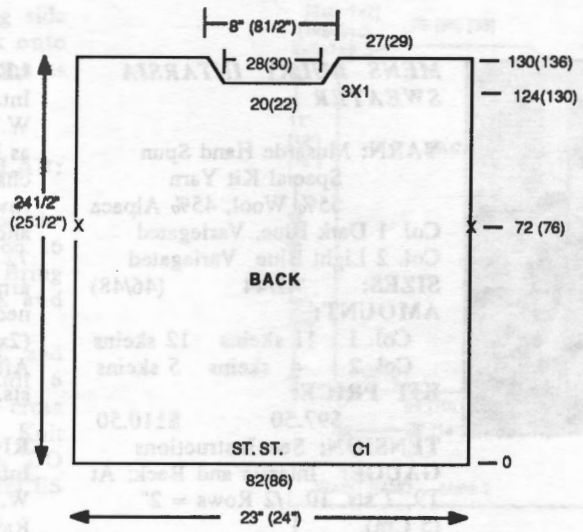
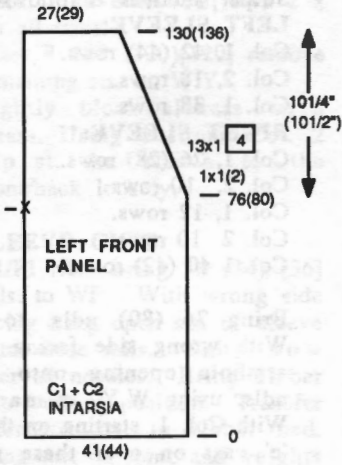



## WOMENS JUMPSUIT

**YARN:** Venetia  
**AMOUNT:** 2 cones  
**KIT PRICE:** \$44.50  
**SIZES:** 8 (12) [16]  
**FULL LENGTH:**  
 54" (55") [56"]  
**TENSION:** 4.2  
**GAUGE:** 18 sts. 23 rows = 2" (5 cm)

Make on Standard Machine in Stockinette stitch. Bands are stockinette st with tension changes.

**BACK:** W.Y. cast on 154 (162) [184] sts. Knit several rows ending with 1 row Ravel Cord to the right. Change to garment yarn. Counter 0. Continue in Stockinette st. and ON EACH SIDE, increase 1 st. every 12 rows 5x. After R 78 (84) [88], SHAPE ARMHOLE: ON EACH SIDE, BO 9 (9) [11] sts. 1x then decrease 1 st. EVERY ROW 7 (6) [9]x, every 2nd row 1 st. 6 (6) [9]x. every 3 rows 1 st. 5 (5) [4]x. Knit to R 172 (182) [190]. SHAPE SHOULDER and watch for NECK SHAPING: For shoulder, BO (or use short row method) 5 sts. 3x, 6 sts. (6 sts. 2x, 7 sts 3x). [7 sts. 4x, 8 sts. 1x] BUT AT THE SAME TIME, after R 176 (186) [194], BO the center 48 (50) [52] sts. put the ndls. on the left into HP and complete the right side first. \*Continuing the shoulder shaping, on neck edge decrease 1 st. every 2 rows 2x. Bring the ndls. on the left to WP, turn Row Counter back to 176 (186) [194] and complete the left half following the instructions from \*.

**FRONT:** Make 1 reverse 1. W.Y. cast on same as you did for back. 131 (136) [144] sts. After Ravel Cord row to the right. Set Counter at 0 and change to garment yarn.

Knit 1 row to the left then put 30 sts. on the right (left for second section) into HP. On every 2nd row, bring back to WP 10 sts. 3x. ON SIDE EDGE, increase 1 st. every 12 rows 5x AND AT THE SAME TIME, on front edge, decrease 1 st. every 3 rows 4x then 1 st. every 2 rows 23x BUT AT THE SAME TIME, after R 79 (85) [89] SHAPE ARMHOLE same as the back After R 168 (174) [178] SHAPE SHOULDER 7 sts 5x (3 sts. 4x, 9 sts. 1x), [8 sts. 1x, 9 sts. 4x]. Knit 2nd section with reverse shaping.

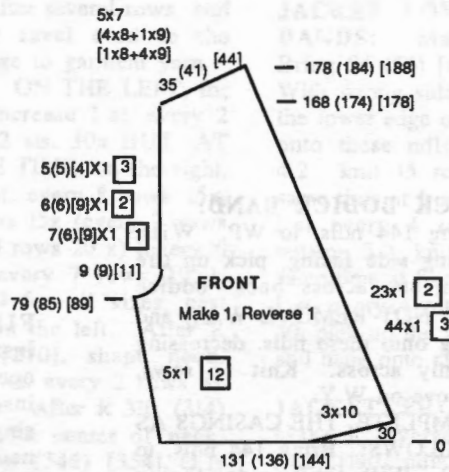
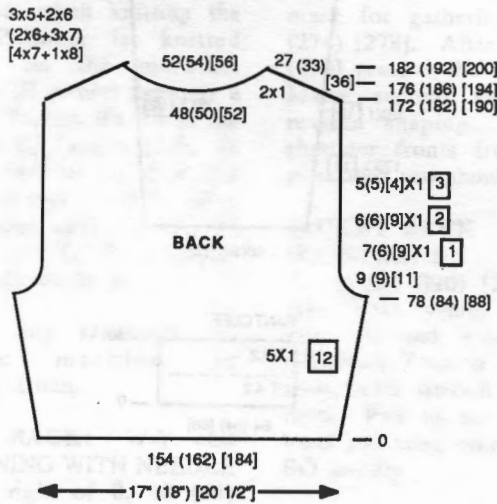

**SLEEVES:** With W.Y. cast on 88 (92) [104] sts. After several rows end with 1 row Ravel Cord to the right. Counter 0, change to garment yarn. Work Stockinette stitch. ON EACH SIDE, increase 1 st. every 11 rows 12x, every 12 rows 2x. After R 178 (178) [182], SHAPE CAP: ON EACH SIDE, BO 9 sts. then decrease 1 st. every 2 rows 7 (8) [12]x, every 3 rows 1 st. 12 (12) [8]x, every 2 rows 1 st. 8 (9) [13]x. After R 246 (250) [258] BO the remaining sts.

**SLEEVE CUFFS:** Make 2. Bring 50 (50) [54] needles to WP. With wrong side facing, hang the open sts. of sleeve onto these ndls. decreasing evenly across. Work Stockinette st. 28 rows T 4.2, 28 rows T 3.2. After R 56, pick up first row of band and BO loosely.

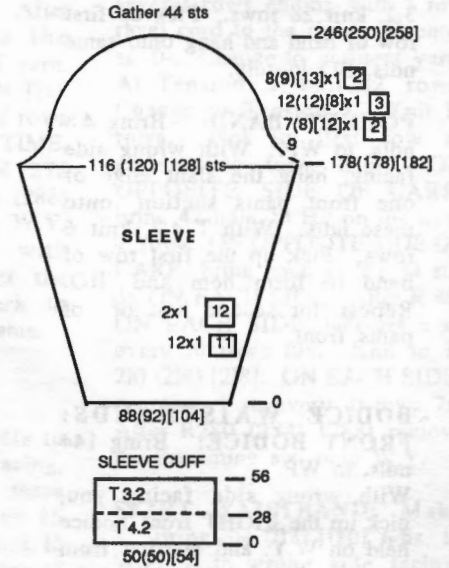

**PANTS FRONT:** Make 1, reverse 1. W.Y. cast on same as before 66 (68) [72] sts. After ravel cord row, change to garment yarn and counter 0. ON INSIDE EDGE, decrease 1 st. every 11 rows 17x, every 10 rows 10x and ON OUTSIDE EDGE, decrease 1 st. every 32 rows 9x. After R 299 (299) [303] SHAPE CROTCH on the inside edge. BO 10 sts. decrease 1 st. every 2 rows 4x, every 17 rows 7x and AT THE SAME TIME, ON OUTSIDE EDGE, after R 348 (350) [356] decrease 1 st. every 3 rows 15x. After R 414 (414) [422] remove the sts. on W.Y.

**PANTS BACK:** Make 1, reverse 1. W.Y. cast on 70 (72) [76] sts. same as you did before. After Ravel Cord row, change to garment yarn, Counter 0. SHAPE THE INSIDE AND OUTSIDE the same as you did for the front (check chart). After R 298 (298) [302] SHAPE CROTCH: BO 10 sts. then decrease 1 st. EVERY ROW 8x. Knit to R 414 (414) [422] then work SHORT ROWS. ON OPPOSITE SIDE OF CARR. bring to HP 22 sts. 4x. Bring all the ndls. back to WP and knit 1 row. Remove the sts. on W.Y.

(continued next page)

(continued from previous page)

**POCKET:** Make 2. Cast on 48 sts. and work stockinette st. to R 110. Remove the sts. on W.Y.

**PANTS CUFFS:** Make 2.

Close the **INSIDE** legs of front and back and crotch first, then bring 64 (64) [68] ndls. to WP. With wrong side facing, Pick up the sts. held on W.Y. for legs and hang onto these ndls. decreasing evenly across. With T 4.2, knit 28 rows, with T 3.2, knit 28 rows. Pick up first row of band and hang onto same ndls. BO loosely.

**POCKET BAND:** Bring 48 ndls. to WP. With wrong side facing, hang the slant edge of one front pants section onto these ndls. With T 4.2, knit 6 rows. Pick up the first row of band to form hem and BO. Repeat for second half of pants front.

**BODICE WAISTBANDS:**

**FRONT BODICE:** Bring 144 ndls. to WP.

With wrong side facing you, pick up the **RIGHT** front bodice held on W.Y. and starting from the left edge, hang the open sts. Leave 28 ndls. on the right **EMPTY** and decrease evenly across to the end ndl. on the left. Hang the **LEFT** open sts. of bodice with the right edge on the end needle and leave the 28 ndls. on the left with only the right bodice sts. on them. Decrease the sts. evenly between. **DO NOT REMOVE THE W.Y.** as you will need the marking later. Knit 6 rows and remove on W.Y.

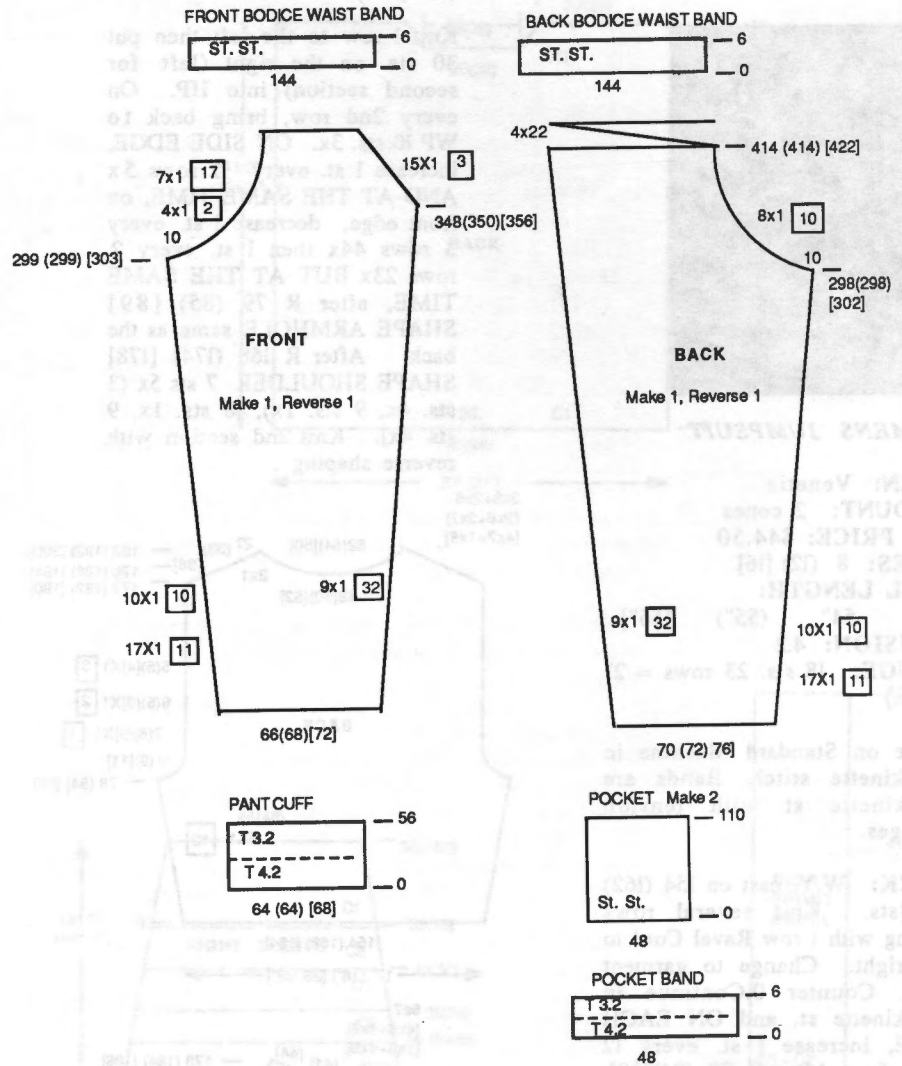

**BACK BODICE BAND:**

Bring 144 ndls. to WP. With wrong side facing, pick up the open sts. across back bodice (**DO NOT REMOVE W.Y.**) and hang onto these ndls. decreasing evenly across. Knit 6 rows, remove on W.Y.

**COMPLETE THE CASINGS AS FOLLOWS:** Bring 144 ndls. to W.P. With knit side facing (right side) hang the pocket sts. on each side first, then hang the open sts. of pants front onto the center ndls. overlapping 7 sts. of the pocket and decreasing evenly across the center. With wrong side (Purl) facing, pick up the **LOWER** sts. held on W.Y. of bodice ( leaving the 6 rows free) and hang onto same ndls. Knit 6 rows then pick up the the sts. held on W.Y. to form a casing. BO loosely. Remove the W.Y. **REPEAT FOR BACK BAND** omitting the pockets instructions.

**FINISHING:** See General Instructions. Leave side seam open on inside at waist and insert elastic. Work 1 row single crochet around front and neck. Sew Pocket down on inside of pants.

**WOMENS 3 PC PEARLYTE ENSEMBLE**

**YARN:** Pearlyte  
**SIZE:** 12 (14) [16]  
**AMOUNT:**

Col. 1 Violet 3 cones all sizes  
 Col. 2 White 1 cone all sizes  
 Col. 3 Monofil - 1 spool

**KIT PRICE:** \$82.00  
**TENSION:** 4.2 for Jacket, 5 for Skirt; Pullover Fair Isle T-3, St. st. for sleeve band, T-2. 1 x 1 ribbing T-0/0 I for Pullover  
**GAUGE:** 15 sts. 22 rows = 2" (5 cm) Jacket; 17 sts. 20 rows = 2" (5 cm) Skirt; 14 sts. 27 rows = 2" (5 cm) Pullover.

You will need spool of matching Polyester sewing thread to add to the Pearlyte when knitting the Skirt. Pullover is knitted sideways on the machine. Compuknit III owners use only a portion of Pattern No. 73 in the Compuknit III Pattern Book. 18 rows are used for the Fair Isle Design. Punch Card machine owners, punch card. Neck and waistband are K1, P1 Ribbing. Sleeve bands are St. st.

Make on any standard or electronic machine in Stockinette stitch.

**JACKET BACK:** W.Y. cast on BEGINNING WITH NEEDLE 18 on the right of 0, 40 (44) [46] sts. After several rows, end with 1 row ravel cord to the right. Change to garment yarn. Counter 0. ON THE LEFT, for all sizes, increase 1 st. every 2 rows 44x, 2 sts. 30x BUT AT THE SAME TIME, on the right, increase 1 st. every 8 rows 15x, every 9 rows 15x (every 7 rows 14x, every 8 rows 20 x) [every 6 rows 10x, every 7 rows 29x]. After R 149 for all sizes, cast on 10 sts. on the left. After R 264 (266) [270], shape neck. Decrease 1 st. every 2 rows 8x for all sizes. After R 310 (314) [320] mark for center of neck. After R 340 (346) [354] ON NECK EDGE, increase 1 st. every 2 rows 8x. Neck shaping completed at R 356 (362) [370] Knit to R 364 (378) [386] then decrease 1 st. every 9 rows 15x, every 8 rows 15x (every 8 rows 20x, every 7 rows 14x) [every 7 rows 29x, every 6 rows 10x]. BUT AT THE SAME TIME, after R 471 (479) [491], cast on 10 sts. on the LEFT and bind off 2 sts. every 2 rows 30x, 1 st. every 2 rows 44x. After R 620 (628) [640] remove the sts. on W.Y.

**JACKET FRONT:** Make 1, Reverse 1. W.Y. cast on 40 (44) [46] sts. After several rows, end with 1 row ravel cord to the right. Counter 0. Change to garment yarn. ON THE LEFT increase 1 st. every 2 rows 44x then cast on 2 sts. every 2 rows 30x AND AT THE SAME TIME, on the right, increase 1 st. every 8 rows 15x, every 9 rows 15x (every 7 rows 14x, every 8 rows 20x) [every 6 rows 10x, every 7 rows 29x]. BUT AT THE SAME TIME, after R 149 for all sizes, cast on 10 sts. on the left. After R 232 (234) [238] mark the right edge with a bit of yarn. After R 255 (257) [261] ON THE LEFT, decrease 1 st. every 2 rows 30x AND AT THE SAME TIME, mark for gathering at R 272 (274) [278]. After R 284 (286) [290] remove the sts. on W.Y. Make second section with reverse shaping. Gather the shoulder fronts from mark to mark then sew shoulder seams.

**JACKET BACK**

**WAISTBAND:**  
 Bring 184 (190) [200] ndls. to WP. With wrong side facing, hang the back waist onto these ndls. With Tension 4.2, knit 15 rows, with tension 3.2, knit 15 rows. Pick up the first row of band and hang onto same ndls. BO loosely.

**JACKET LOWER FRONT**

**BANDS:** Make 1, reverse 1. Bring 54 (56) [60] ndls. to WP. With wrong side facing, pick up the lower edge of front and hang onto these ndls. With tension 4.2 knit 15 rows and at the same time at front edge, increase 1 st. every 4 rows 3x. With tension 3.2, knit 15 rows and at same time at front edge, decrease 1 st. every 4 rows 3x. After R 30, pick up the first row of band and hang onto same ndls. BO.

**JACKET FRONT BANDS:**

Make 1, reverse 1. Bring 174 (182) [190] ndls. to WP. With wrong side facing, pick up the front edge and INCLUDE the lower front shaping (see chart). Knit the same as the lower Front Bands.

**JACKET SLEEVE BANDS:**

Shoulder seams must be completed. Front shoulders should have been gathered between markers. Bring 50 (54) [56] ndls. to WP. With wrong side facing, hang the sleeve edge onto these ndls. Knit the same as the back waistband.

**JACKET BACK NECKBAND:**

Bring 54 (56) [60] ndls. to WP. With wrong side facing, hang the back neck edge onto these ndls. With tension 4.2, knit 15 rows. With tension 3.2, knit 15 rows. Pick up the first row of band and hang onto same ndls. BO.

**SKIRT:** Make 2 sections the same. Use a strand of Polyester thread together with yarn. W.Y. cast on 148 (152) [160] sts. Knit several rows ending with 1 row ravel cord to the right. Counter at -0-. Change to garment yarn. At Tension 4 knit 12 rows. Change to Tension 5. Knit 12 rows. Pick up first row of garment to form hem. ON OPPOSITE SIDE OF CARR. bring 42 ndls. to HP on the next 2 rows. ON OPPOSITE SIDE OF CARR. bring back to WP 14 sts. 3x ON EACH SIDE. After R 40, ON EACH SIDE, increase 1 st. every 10 rows 10x. Knit to R 210 (214) [218]. ON EACH SIDE, decrease 1 st. every 10 rows 7x. After R280 (284) [288] remove the remaining sts. onto W.Y.

**SKIRT WAISTBAND:** Make 2. Bring 104 (112) [120] ndls. to W.P. with wrong side facing, hang the open sts. of waist onto these ndls. decreasing evenly across. With tension 5, knit 17 rows, with tension 4, knit 17 rows. Pick up first row of band and hang onto these ndls. BO.

**FINISHING FOR SKIRT**

**AND JACKET:** See General Instructions. Close side seams. Weave the ends of bands together. Insert elastic in waistband.

**PULLOVER BACK and**

**FRONT:** The same. W.Y cast on 160 (167) [174] sts. Knit several rows ending with 1 row ravel cord to the right. Counter 0, change to Color 1. Mark needle 60 (64) [68] with a bit of contrast yarn for arm opening. Knit 7 rows then set Fair Isle Pat. from left to right. Knit 18 rows Fair Isle Pat with colors 1 and 2. Stop pattern and with color 1, knit 18 (20) [22] rows St. st. setting pattern at row 43 (45) [47]. Continue to follow Chart, knitting 18 rows pattern, then stop pattern and knit 18 (20) [22] rows St. st. Watch the row numbers on the Chart. At the same time, after R 70 (72) [74] SHAPE NECK:  
 (continued next page)



(continued from previous page)  
 Decrease 1 st. EVERY ROW 10x.  
 Continue in pattern. After R 124  
 (130) [136] mark for center of  
 neck. After R 170 (178) [186]  
 increase 1 st. EVERY ROW 10x.  
 Mark armhole same as before.  
 After R 250 (262) [274] remove  
 the sts. on W.Y.

**WAISTBAND:** Make 2.  
 K1, P1 Ribbing T-0/0 II. With  
 Color 2 and 1 strand Color 3  
 together, cast on 139 (147) [155]  
 sts. Knit 40 rows. Transfer  
 ribber sts. to MB, pick up  
 front/back waist and hang onto  
 these ndls. decreasing evenly  
 across. BO loosely.

**NECKBAND:** Close one  
 shoulder first. K1, P1 Ribbing T-  
 0/0 II. With Color 2 and 1  
 strand Color 3 together, cast on  
 161 (169) [177] sts. Knit 12  
 rows. Transfer ribber sts. to MB.  
 Beginning at open shoulder,  
 pick up sts. around neckline and  
 hang onto these ndls. BO  
 loosely.

**SLEEVE BANDS:** Close  
 second shoulder. Bring 132  
 (136) [140] ndls. to WP. With  
 wrong side facing, pick up sts.  
 along armhole and hang onto  
 these ndls. T-2. With Color 2,  
 work St. st. to Row 16. Pick up  
 first row of band and hang onto  
 the machine. Bind off loosely.

**FINISHING PULLOVER:**  
 With wrong sides together, sew  
 side seams from waist edge to  
 markers for armholes. Close  
 double bands.

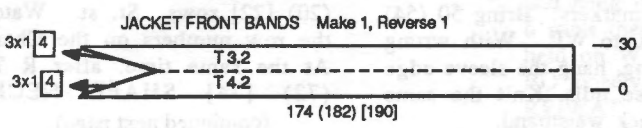
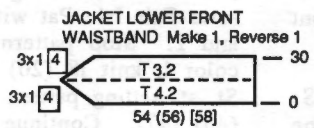
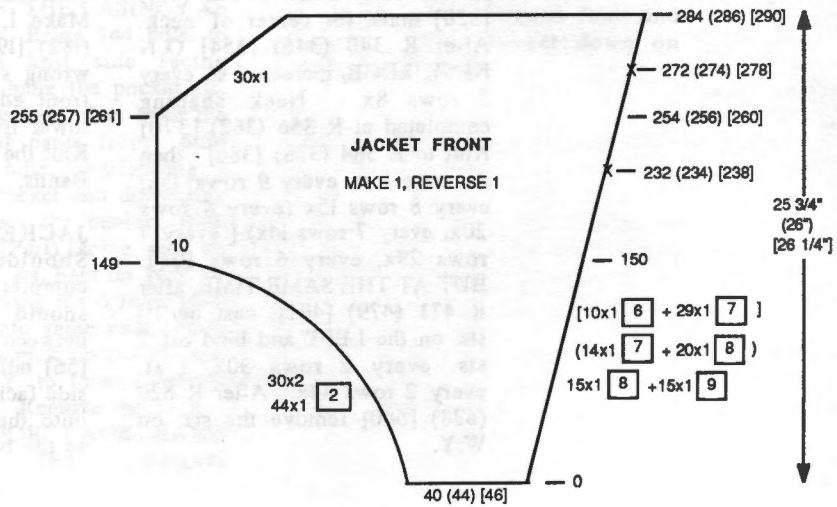
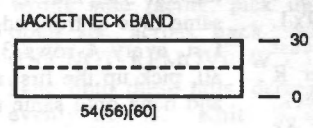
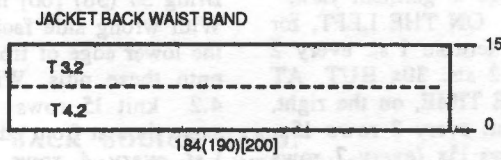
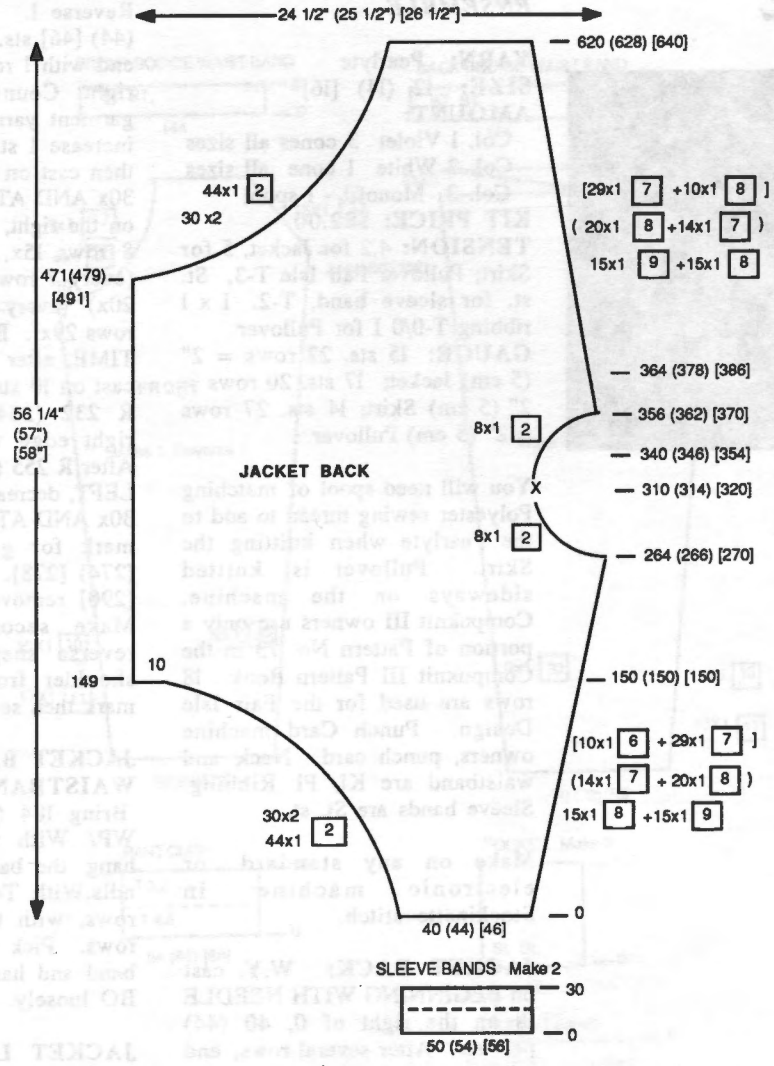



SKIRT WAIST BAND

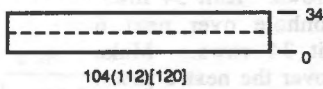

STITCH = 8  
ROW = 20

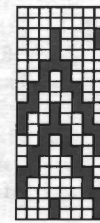

PULLOVER SLEEVE BAND

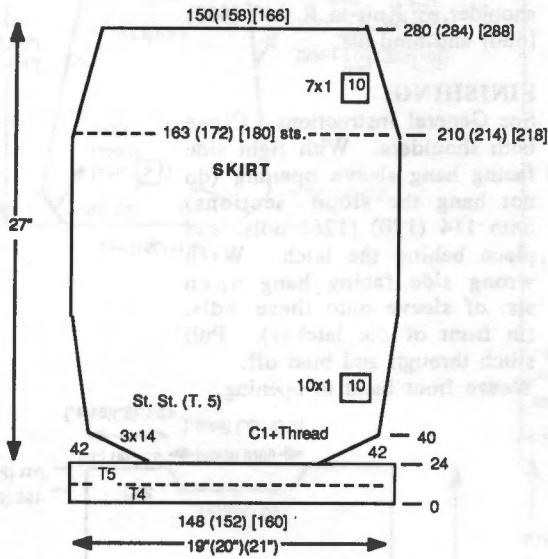
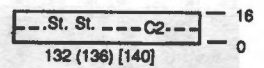

PULLOVER BACK & FRONT

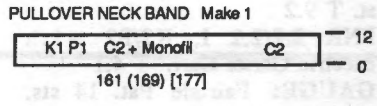
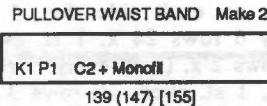
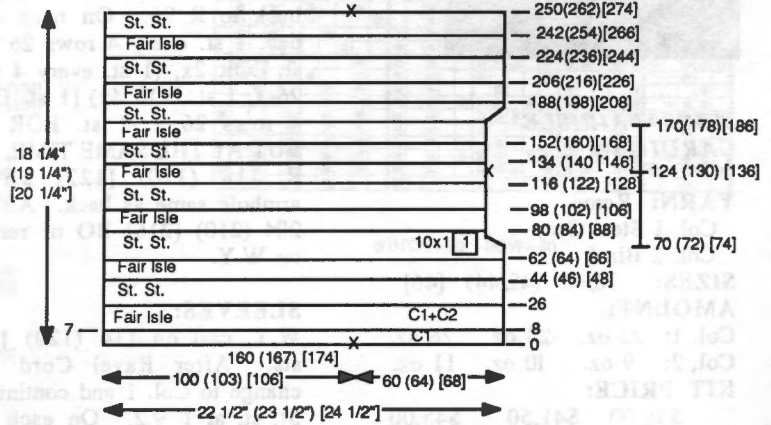

# FDD19

## FLOPPY DISK DRIVE FOR COMPUKNIT III



The Floppy Disk Drive makes pattern work unbelievably easy. There are many programmed Disks available, including one for pattern stitch designs from each edition of KNITTING MAGAZINE. Invest in a Floppy Disk Drive today and start your own pattern stitch Disk collection.

## STITCH WORLD EXTRAS . . . . Pattern Stitch Book and Programmed Disk



A complete new and marvelous (very contemporary) assortment of 63 Pattern Stitches for the COMPUKNIT III. Fair Isle, Single Motifs, Thread Lace, Regular and Fine Lace, Skip Stitch, Tuck Stitch, and Garter Stitch. Up to 200 stitches wide. Pattern number 667 in this issue is one of the excellent pattern stitch designs illustrated in the Book and programmed onto the Disk.

Order from your local KNITTING DEALER or direct from KNITTING at 1128 Crenshaw Blvd., Los Angeles, CA 90019.



### MENS FAIRISLE CARDIGAN

**YARN:** Roma  
Col. 1 Steel Grey  
Col. 2 Black

**SIZES:** 38/40 (42/44) [46]

**AMOUNT:**

Col. 1: 22 oz. 24 oz. 26 oz.

Col. 2: 9 oz. 10 oz. 11 oz.

**KIT PRICE:**

\$38.00 \$41.50 \$45.00

**TENSION:** Fairisle T 10, St. st. T 9.2

**FNR** 2.2/2.2 I, K2/P2 with Electric Garter Carr. T 4.1

**GAUGE:** Fairisle Pat. 14 sts. 19.5 R = 2" (5 Cm)

Sleeves 14 sts. 17.5 R = 2"

**NOTIONS:** 4 Buttons.  
Approx. 3/4"

Make on any Electronic Machine with Ribbing ability. Pattern is Fairisle design.

**NOTE:** Col. 1 = 2 strands together throughout.  
Col. 2 = 2 strands together throughout.

**BACK:** Fairisle pattern. Make 1  
W.Y. cast on 156 (166) [172] st. After several rows end with 1 row Ravel Cord to the right. Change to Col. 1 and at T 10 knit 1 row to the left. Set Fairisle pattern, press Variation Key 3 and 4 for double length and double width, and knit to the right to select needles. With Col. 2 in feeder - B- continue in Fairisle Pattern. After R 118 (120) [122] ON EACH SIDE dec. 1 st. 1x all sizes, then 2 sts. 9 x, (2 sts. 9 x), [2 sts. 8 x]. After R 198 (204) [210] shape neck. **MARK PLACE IN PATTERN.** BO the center 50 (52) [54] sts. Place the sts. on the left into HP and complete the right side first. \*On neck edge dec. 2 sts. EOR 2x. After

R 204 (210) [216] BO or remove remaining sts. on W.Y. Bring sts. on the left back into WP. Make sure the sts. are in the hooks of the needles. Return to correct place in pattern and select the needles. Turn counter back to R 198 (204) [210] and complete to match the right side following instructions from \*.

**FRONT:** Make 1, Reverse 1. W.Y. cast on 77 (83) [87] sts. same as back and knit same as back to R 96. On neck edge dec. 1 st. every 4 rows 26 x, 1 st. EOR 2x, (1 st. every 4 rows 26 x, 1 st. EOR 4x) [1 st. Every 4 rows 26 x, 1 st. EOR 6x]. **BUT AT THE SAME TIME,** after R 118 (120) [122] shape armhole same as back. After R 204 (210) [216] BO or remove on W.Y.

**SLEEVES:**

W.Y. cast on 114 (120) [126] sts. After Ravel Cord row, change to Col. 1 and continue in St. st. at T 9.2. On each side Inc. 1 st. EOR 11 (12) [13] x. Then on each side dec. 1 st. every 6 rows 24 x, 1 st. every 10 rows 2 x, (1 st. every 5 rows 30 x, 1 st. every 10 rows 3 x), [1 st. every 5 rows 33 x, 1 st. every 10 rows 2x]. After R 200 (206) [212] remove on W.Y.

**SLEEVE CUFFS:** Made on the Electric Garter Carriage at T 4.1.

**K2/P2 RIB:** With Col. 1 cast on 66 (68) [70] Sts. Knit 34 rows. With wrong side facing hang open sts. of sleeve onto these ndls. decreasing evenly across. BO loosely.

**BACK WAIST BAND:** Made on the Electric Garter Carriage at T 4.1.

**K2/P2 rib.** With Col. 1 cast on 156 (164) [172] sts. Knit 34 (36) [38] rows. With wrong side facing hang open sts. of Back onto these needles and BO loosely.

**FRONT WAIST BANDS:** Make 2.

**K2/P2 Rib.** Cast on, same as other bands 80 (83) [87] sts. Knit 34 (36) [38] rows. With wrong side facing hang open sts. of front panel onto these needles and BO.

**FRONT AND NECK BAND:** Make 1.

**FNR:** With Col. 1 cast on 12 sts. After Selvedge knit 6 (8) [10] rows. Make button hole in

center over next 6 rows. Knit 34 rows. Make buttonhole over the next 6 rows. Knit 34 rows. Make buttonhole over next 6 rows. Knit 34 rows. Make buttonhole over the next 6 rows. Row 132 (134) [136]. Knit to R295 (303) [310] and mark with W.Y. for shoulder. Knit to 320 (330) [340] and mark for center back, continue knitting to R 345 (357) [370] and mark for shoulder. Knit to R 640 (660) [680] and bind off.

**FINISHING:**

See General Instructions. Close both shoulders. With right side facing hang sleeve opening (do not hang the slope sections) onto 114 (120) [126] ndls. and place behind the latch. With wrong side facing hang open sts. of sleeve onto these ndls. (in front of the latches). Pull stitch through and bind off. Weave front band to opening.

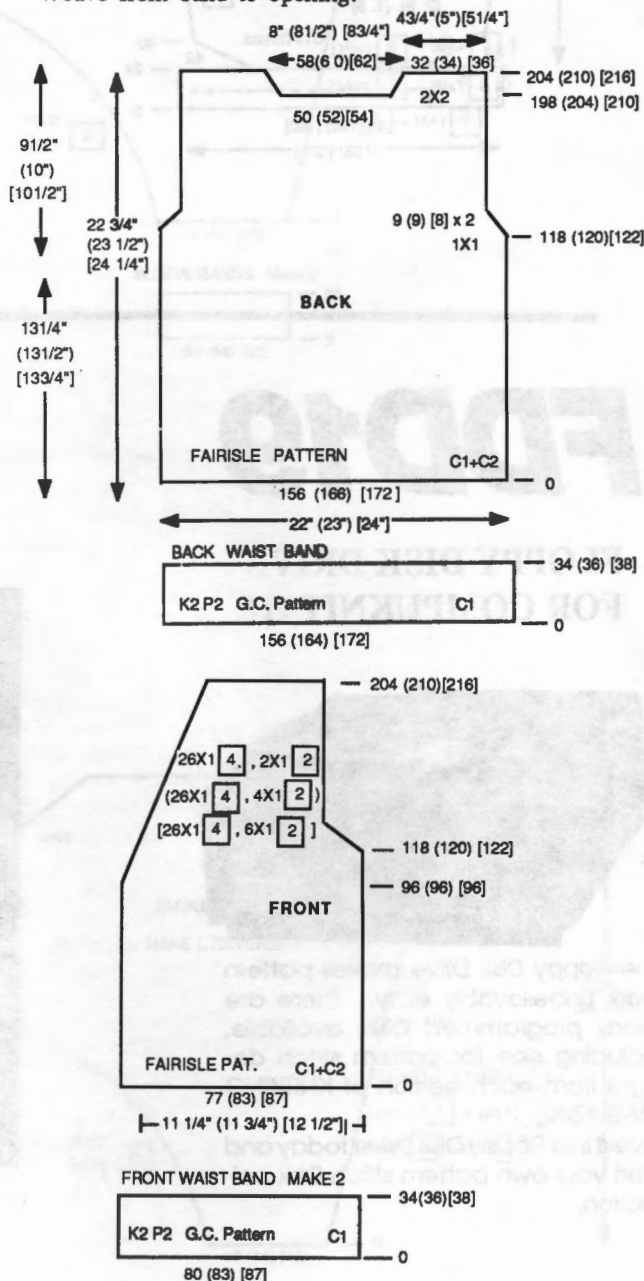

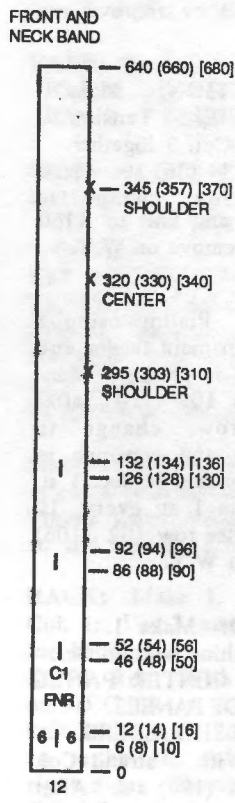
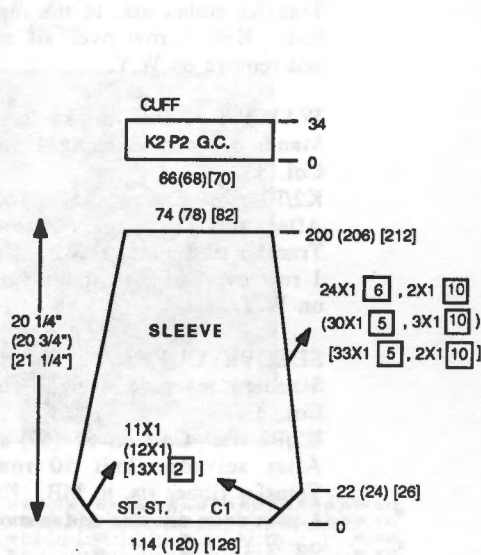

1	2	3	4	5	6	7	8	9	10	11	12	13	14	15	16	17	18	19	20	21	22	23	24	25	26	27	28	29	30	31	32	33	34	35	36	37	38	39	40	41	42	43	44	45	46	47	48	49	50	51	52	53	54	55	56	57	58	59	60	61	62	63	64	65	66	67	68	69	70	71	72	73	74	75	76	77	78	79	80	81	82	83	84	85	86	87	88	89	90	91	92	93	94	95	96	97	98	99	100
1	2	3	4	5	6	7	8	9	10	11	12	13	14	15	16	17	18	19	20	21	22	23	24	25	26	27	28	29	30	31	32	33	34	35	36	37	38	39	40	41	42	43	44	45	46	47	48	49	50	51	52	53	54	55	56	57	58	59	60	61	62	63	64	65	66	67	68	69	70	71	72	73	74	75	76	77	78	79	80	81	82	83	84	85	86	87	88	89	90	91	92	93	94	95	96	97	98	99	100

STITCH = 30 ROW = 40

# knitking *news*

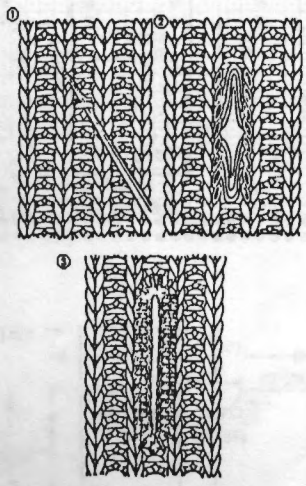

## RIBBING BUTTONHOLE

The reversible Caprinae (Mohair) and Venetia jacket, Pattern 712, has a Rib band with buttonholes. The illustration on the left shows a simple way to make a small buttonhole. With a crochet hook, spread and pull the knitting apart for as many rows needed for an opening. Tack the opening at each end then work a buttonhole stitch all around the opening. Use matching buttonhole twist or fine matching yarn.

## REVERSE SHAPING MADE EASY

When you have two sections of a garment - one to knit in reverse, an easy way to do this is simply to change the Row Counter side for the second section. Normally, even numbers are on the right side - so you need only to change the Row Counter so that even numbers are on the left side while you are knitting. In this way, you can follow the instructions exactly with no confusion.

## MOVING OR CHANGING ADDRESSES??

If so, you can insure the proper handling of this change by following the three suggestions below:

- 1) When advising us of your new address, please also indicate your old address.
- 2) Please provide us with six weeks notice to affect this change.
- 3) PLEASE PRINT ALL INFORMATION LEGIBLY.

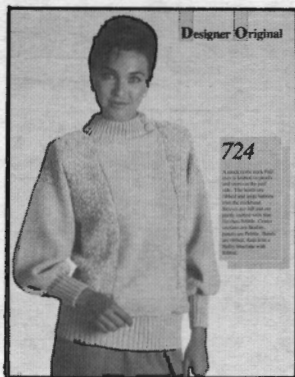

## WOMENS BULKY PULLOVER

### YARN:

Col. 1 Pebble  
Col. 2 Glace  
Col. 2 Starlite  
Col. 3 Venetia

SIZES: 6/8 (10/12)

### AMOUNT:

Col. 1 1 cone all sizes  
Col. 2 1 cone all sizes  
Col. 3 1 cones all sizes  
Col. 3 1 cone all sizes

KIT PRICE: \$75.00

TENSION: See instructions.

GAUGE: Back and Front Plating at T 4.2 = 8.5 sts. 12.5 rows = 2" (5 Cm) St. st. for Front sections, 11 sts. 18 rows = 2" (5 Cm)

Sleeves T 2, 9.5 sts. 15 rows = 2" (5 Cm)

NOTIONS: Optional (2 buttons for collar)

Main body of Pullover was made on the Bulky machine. Ribbing was knitted on the standard machine with Ribber. The Purl Side is the right side.

**BACK:** Make 1. Tension 4.2

Plating: Use 1 strand Col. 1 in main feeder and 1 strand Col. 2 in plating feeder.

W.Y. cast on 80 (86) sts. After several rows end with 1 row Ravel Cord to the right. Change to garment yarn and continue in plating to row 52 (56). Mark each side with W.Y. for sleeve opening. After R 124 (130) Mark neck opening with W.Y. and BO or remove each section on W.Y.

**FRONT:** Make 1, Reverse 1.

**SIDE PANELS:** T 4.2  
W.Y. cast on 28 (30) sts. After Ravel Cord row, change to garment yarn and continue in plating same as back. After R 52 (56) mark for armhole. After R 110 (114) shape neck edge.

Dec. 1 st. EOR 2 x. After R 124 (130) BO or remove on W.Y.

**FRONT SECTION:** Make 1.  
**CENTER PANEL:** Tension 2. Use 2 strands Col. 3 together. W.Y. cast on 34 (36) sts. After Ravel Cord row, change to garment yarn and knit to R160 (164). BO or remove on W.Y.

**SLEEVES:** Plating using 1 strd. Col. 4 in main feeder and 1 strd. Col. 3 in plating feeder. W.Y. cast on 109 (114), after ravel cord row, change to garment yarn and continue in Plating. On each side dec. 1 st. EOR 5 x, then 1 st. every 10 rows 9 x. After row 102 (106) remove sts. on W.Y.

**NECK BAND:** Make 1. Standard machine with Ribber. JOIN FRONT CENTER PANEL TO FRONT SIDE PANELS. CLOSE BOTH SHOULDERS. K2/P2 rib: With 1 strand Col. 3, cast on 191 (199) sts. After

selvage at T 3/3 I knit 60 rows. Transfer ribber sts. to the main bed. Knit 1 row over all sts. and remove on W.Y.

**WAIST BANDS:** Make 2. Standard machine using 1 strd. Col. 3  
K2/P2 rib: Cast on 152 (160). After selvage knit 50 rows. Transfer ribber sts. to MB. Knit 1 row over all sts. and remove on W.Y.

**SLEEVE CUFFS:** Standard machine using 1 strd. Col. 3  
K2/P2 rib: Cast on 65 (69) sts. After selvage knit 50 rows. Transfer ribber sts. to MB. Knit 1 row over all sts. and remove on W.Y.

**FINISHING:** See General Instructions. Weave neck Band to neck opening. Weave cuffs to sleeve and waistband to garment. Overlap slightly in front. See Photo. Attach sleeves and sew side seams.

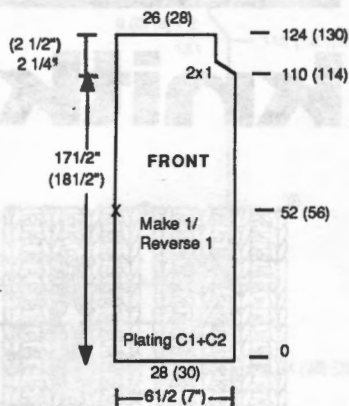
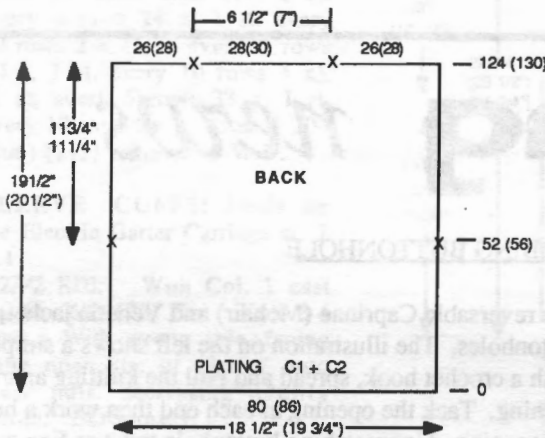

WAIST BAND MAKE 2 - Standard Machine & Ribber

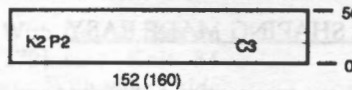

CUFF - Made on Standard Machine and Ribber

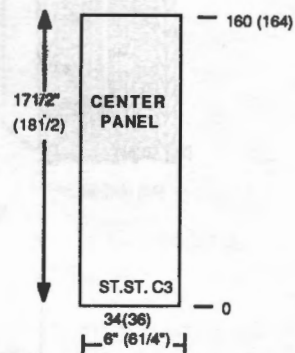
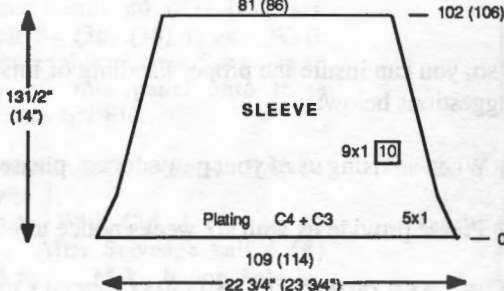
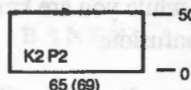

NECK BAND Made on Standard Machine and Ribber

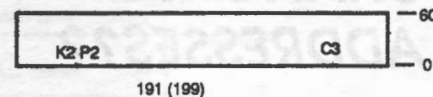

**MENS BULKY THREAD LACE PULLOVER**

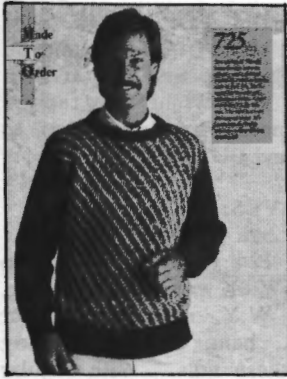

**YARN:** Special Kit Yarn  
 Col. 1: Wool/Angora Tweed  
 Col. 2: White and Brown Tweed

**SIZES:** 40/42 (44/46)  
**AMOUNT:**

Col. 1 18 oz. 20 oz.  
 Col. 2 6 oz. 8 oz.

**KIT PRICE:** \$20.00 \$22.00

**TENSION:** Thread Lace T 2.2, Ribbing T 0/0 II.

**GAUGE:** Thread Lace 9.5 sts. 13.5 rows = 2", St. st. 10 sts. 14 rows = 2" (5 Cm)

Make on the Punch Card Bulky machine with Ribber. Pattern is Thread Lace. Sleeves are in st. st. and Ribbing K1/P1.

**BACK:** Make 1.  
 Col. 1: Use 3 strands together for Ribbing.

K1/P1 Rib: With Col. 1, cast on 105 (111) st. After selvedge, knit 26 rows. Transfer ribber sts. to the ME. Add 1 st. on the right side. Remove 1 strand Col. 1 from feeder. (Thread Lace pattern uses 2 strands Col. 1 in Feeder -A- and 1 strand Col. 2 in Feeder -B- throughout). With Col. 1, knit 1 row to the left. Release end needle selection mechanism (see page 42 in Manual). Set carriage to KC and knit to the right to select ndls. Add Col. 2 to feeder -B- and press in BOTH center buttons on carr. Release punch card (GO) and continue in thread lace pattern. After R 120 (122), shape armhole. On each side BO 2 sts. 1 x, (1 st. 1 x), 3 sts. EOR 3 x. After R 182 (188), BO the center 36 (38) sts. Mark place on punch card. Place sts. on the left into HP and complete the right side first. \*On neck edge BO 1 st. EOR 2 x. After R 188 (194) BO the remaining sts. Bring the sts. on the left back into WP. (sts. must be in the hooks of the ndls.) Turn card

back to Mark. Turn counter back to 182 (188). Select ndls. for pattern and knit left side to match the right side following instructions from \*.

**FRONT:** Make 1.  
 Same as Back to R 170 (174). Bind off the center 18 (20) sts. Place the sts. on the left into HP and complete the right side first. Be sure to mark place in pattern. \*On neck edge BO 3 sts. 2 x, 2 sts. 1 x, 1 st. 3 x. After R 188 (194) BO the remaining sts. Return ndls. on the left to WP. Set pattern. Turn row counter back to R 170 (174) and knit to match the right side following instructions from \*.

**NECK BAND:** Make 1.  
 Close 1 shoulder first.  
 K1/P1 rib: With 3 strds. Col. 1, cast on 95 (101) sts. After selvedge knit 20 rows. Transfer Ribber sts. to Main Bed. Pick up 1st. row to form hem. With wrong side facing, hang neck opening onto these ndls. and BO loosely.  
 Close 2nd. shoulder.

**SLEEVES:**  
 Col. 1 only. Use 2 strands together. T 2.  
 'e' cast on 89 (92) sts. Knit 1 row. On each side inc. 1 st. EOR 1 x (2x), 1 st. every 3rd. row 5 x. After R 18 on each side decrease 1 st. every 6th row 21 (22) x. After row 146 (150) remove on W.Y.

**SLEEVE CUFFS:** Use 3 strds. Col. 1 together at T 0/0 II  
 K1/P1 rib: With Col. 1 cast on 33 (39) sts. After selvedge knit 26 rows. Transfer Rib sts. to MB. With wrong side facing hang open sts. of sleeve edge onto these ndls. decreasing evenly across. BO loosely.

**FINISHING:**  
 See General Instructions.  
 Sew in sleeves. Close side seams. Close neck band.

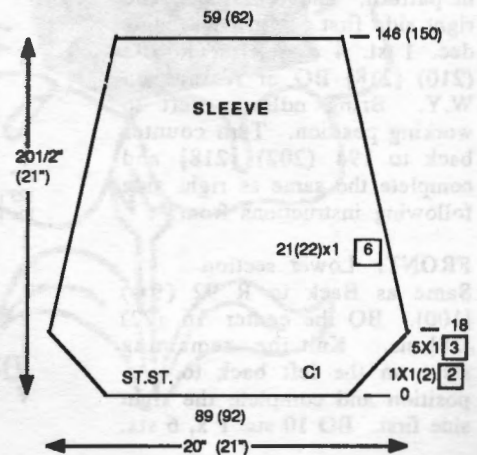
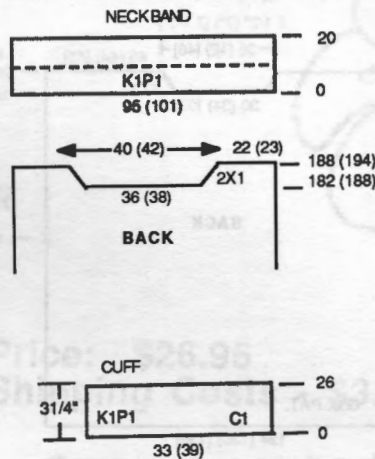
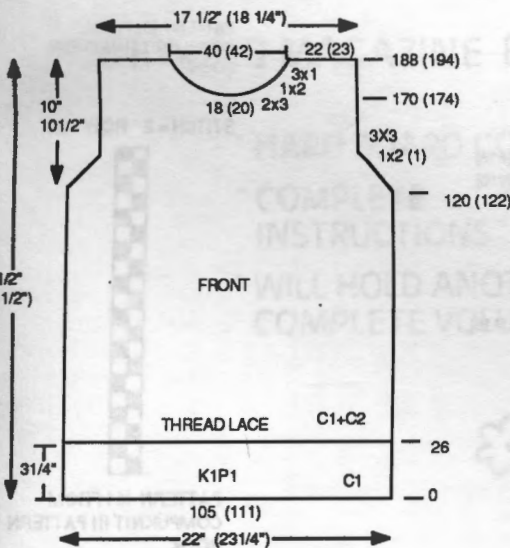
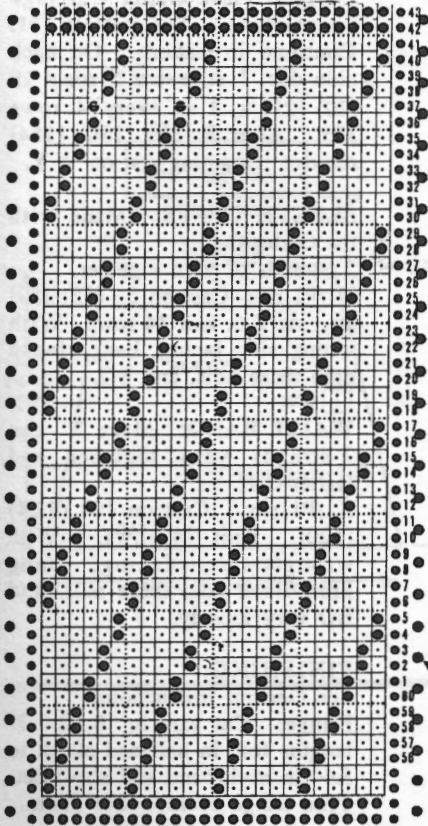



**FRINGED PULLOVER**

**YARN:** Acrylite  
**SIZES:** 6/8 (10/12) [14]  
**AMOUNT:**  
 28 oz. 29 oz. 30 oz.  
**KIT PRICE:**  
**TENSION:** Garter Carr: T 10  
**GAUGE:** Pattern #1: 12 sts.  
 18 rows = 2" (5 Cm)  
 Pattern #2: 11 sts. 19 rows = 2"  
 (5 Cm)

Make on the Electronic Machines with the Garter Carriage. Punch Card owners can easily adapt a suitable pattern for the 24 stitch card.

**BACK:** Make 1. Use 2 strands Acrylite together throughout.  
 W.Y. cast on 124 (130) [136] sts. After several rows end with 1 row Ravel Cord to the right. Change to garment yarn. Program pattern #1. Place Garter Carr. on needle bed and continue in pattern. After R 110 (114) [118] mark each side with W.Y. for sleeve. After R 194 (202) [210] shape neck opening. BO the center 30 (34) [38] sts. Place the remaining sts. on the left into HP ( In this case since we are using the G.C. be sure to knit the sts. back to -A-Position). Record or mark place in pattern, and complete the right side first. \*On neck edge, dec. 1 st. 4 x. After R 202 (210) [218] BO or remove on W.Y. Bring ndls on left to working position. Turn counter back to 194 (202) [218] and complete the same as right side following instructions from \*.

**FRONT:** Lower section Same as Back to R 92 (96) [100]. BO the center 16 (22) [28] sts. Knit the remaining sts. on the left back to -A- position and complete the right side first. BO 10 sts. 1 x, 6 sts.

1 x, 4 sts. 1 x, 3 sts. 2 x, 2 sts. 6 x, 1 st. 11 x, 1 st. every 4 rows 5 x. BUT AT THE SAME TIME, after R 110 (114) [118] mark for sleeve. After R 158 (162) [166] BO the remaining sts.  
 Bring sts. on the left back into WP. Turn counter back to R 92 (96) [100]. Set correct row for pattern and knit to match the right side reversing shaping.

**FRONT:** Upper section inset. 2 strds. together.  
 W.Y. cast on 114 (120) [126] sts. After Ravel Cord row change to garment yarn and starting at the left side, -e- cast on over these ndls. With regular carr. knit 2 rows. Set Pattern #2. Place G.C. onto machine. Leave the center 14 (20) [26] sts. in WP. On each side knit back to -A- position all ndls. Shape front inset by bringing additional ndls. to working position. On each side, bring to WP 9 sts. 1 x, 5 sts. 1 x, 4 sts. 1 x, 3 sts. 2 x, 2 sts. 4 x, 1 st. 12 x, 1 st. every 5 rows 6 x. After row 96 (100) [104] shape neck. BO the center 12 (14) [16] sts. Knit the remaining sts. on the left back to -A- position, and complete the right side first. BE SURE TO MARK PLACE IN PATTERN. On neck edge dec. 1 st. EOR 13 x. After R 124 (128) [132] BO or remove sts. on W.Y. Bring sts. on the left back into WP. Be sure sts. are in the hooks of the ndls. Turn counter back to R 96 (100) [104], return to place in pattern, complete to match the right side.

**NECK BAND:** Make 1. Made with Garter Carr.

Sew upper front inset to lower front.  
 Close 1 shoulder. Use 4 strand only.  
 K1/P1 rib: Cast on 140 (148) [156] sts. At T 1.2 knit 80 rows. Pick up first row to form hem. With wrong side facing, hang neck opening onto these ndls. and BO.

**SLEEVES:**  
 Close 2nd. shoulder.  
 Bring 124 (130) [136] ndls.to WP. With wrong side facing, using W.Y. markers as your guide., hang sleeve opening onto these ndls. With regular carriage, knit 1 row, from left to right. Place Garter Carriage on machine. Set pattern #1. Continue in pattern. On each side dec. 1 st. every 5 rows 19 (20) [21] x, 1 st. every 4 rows 12x. After R 146 (150) [154] remove remaining sts. on W.Y.

**SLEEVE CUFFS:** Made with the Garter Carr.  
 2 Strands of yarn together.  
 K1/P1 rib: Cast on 51 (55) [59] sts. At T 6, knit 34 rows. With wrong side facing, hang sleeve onto these ndls. and BO.

**WAIST BAND:** Make 2. Use 2 strands yarn together and Garter Carr.  
 K1/P1 rib: Cast on 108 (114) [120]. Knit 34 rows. With wrong side facing, hang Front/Back onto these ndls. and BO very loosely.

**FINISHING:**  
 See General Instructions.  
 Fringe: Cut yarn in 6 1/2 - 7" lengths fold in half and attach to fold in neck band and also inset. Trim fringe evenly. See Photo.

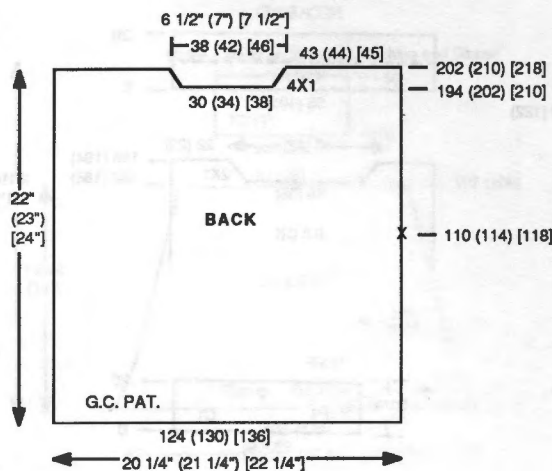

PATTERN 461 FROM  
 COMPUKNIT III PATTERN  
 BOOK

STITCH = 2 ROW = 20



PATTERN 461 FROM  
 COMPUKNIT III PATTERN  
 BOOK

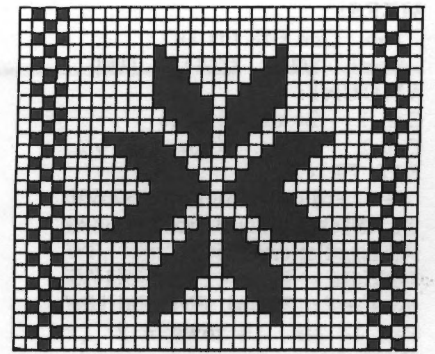
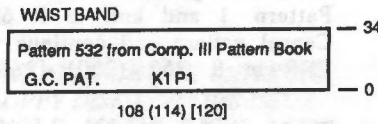
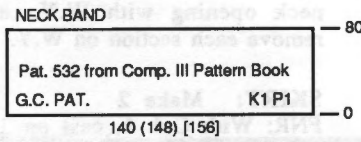
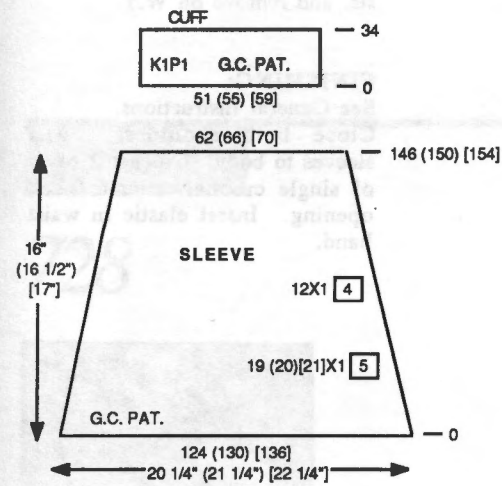
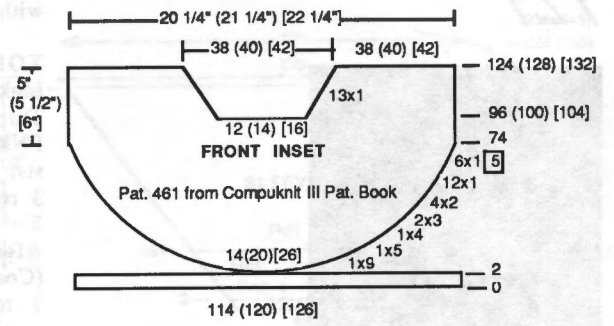
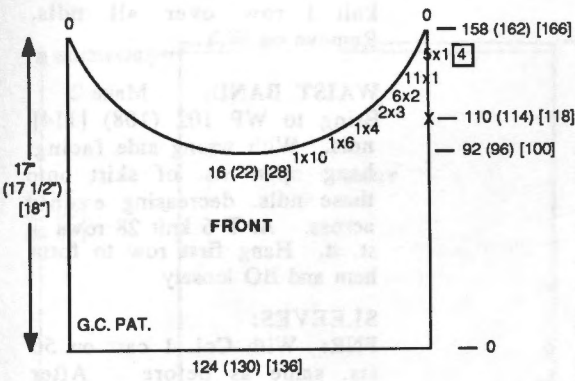

STITCH = 33 ROW = 28

# IT'S READY NOW!

KNITTING MAGAZINE BOUND VOLUME **22**

- HARD BOARD COVER
- COMPLETE INSTRUCTIONS
- WILL HOLD ANOTHER COMPLETE VOLUME

 Price: \$26.95  
Shipping Costs - \$3.50





## WOMENS OVERSIZED TOP AND SKIRT

**YARN:** Acrylite

Col. 1 Red

Col. 2 Grey

**SIZES:**

Top: One size fits all.

Skirt: 8/10 (12/14) [16]

**AMOUNT:**

Col. 1 24 oz. all sizes

Col. 2 18 oz. 20 oz. 22 oz.

**KIT PRICE:**

\$34.50 \$36.00 \$37.50

**TENSION:** FNR 5/5 I, FNR Fairisle Pattern 5/5 lili.

**GAUGE:** FNR 11.5 sts. 17.5 rows = 2" (5 Cm), FNR Fairisle Pat. 14 sts., 16 rows = 2" (5 Cm).

Make on any Electronic Machine with Ribber and Color Changer.

**TOP:** Front/Back the same. Make 2

Thread Col. 2 in Color Changer  
**FNR:** With Col. 1 cast on 194 sts. After regular selvedge, knit 3 rows. Carriage on the left. Set Pat. 1 and begin Fairisle. After R 63, set Pattern 2. (Compuknit III owners program 1 motif on Yellow 77 and 1 motif on Green 29). After R 155 set pattern 3. (be sure to use key 3 & 4 for double width and double length). After R 196, mark each side with W.Y. for sleeve opening. Continue in pattern to row 339. Set Pattern 2 same as before and knit to R 431. Transfer ribber sts. to MB. Knit 1 row over all sts. Mark neck opening with W.Y. and remove each section on W.Y.

**SKIRT:** Make 2

**FNR:** With Col. 1, cast on 112 (120) [128] sts. same as Top. After selvedge, knit 3 rows. Set Pattern 1 and knit to R 63. Cancel pattern and continue in FNR to R 252 (260) [268].

Transfer ribber sts. to MB and knit 1 row over all ndls. Remove on W.Y.

**WAIST BAND:** Make 2.

Bring to WP 102 (108) [114] ndls. With wrong side facing, hang open sts. of skirt onto these ndls. decreasing evenly across. At T 6 knit 28 rows in st. st. Hang first row to form hem and BO loosely.

**SLEEVES:**

**FNR:** With Col. 1 cast on 50 sts. same as before. After selvedge, knit 3 rows, set Pat. 1 and continue in Fairisle. ON EACH SIDE inc. 1 st. every 3 rows 20 x, 1 st. EOR 40 x. After R 63, cancel Fairisle pattern and continue in plain FNR to 145. Transfer ribber sts. to MB and knit 1 row over all sts. and remove on W.Y.

**FINISHING:**

See General Instructions. Close both shoulders. Join sleeves to body. Crochet 2 rows of single crochet around neck opening. Insert elastic in waist band.

PAT. 1

STITCH = 24 ROW = 30

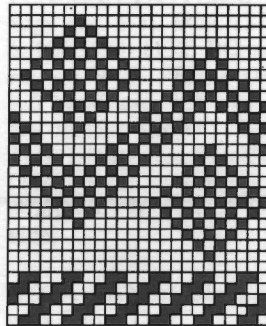

WAIST BAND MAKE 2

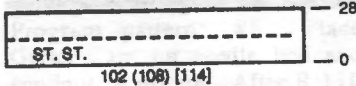

PAT. 2

STITCH = 49 ROW = 47

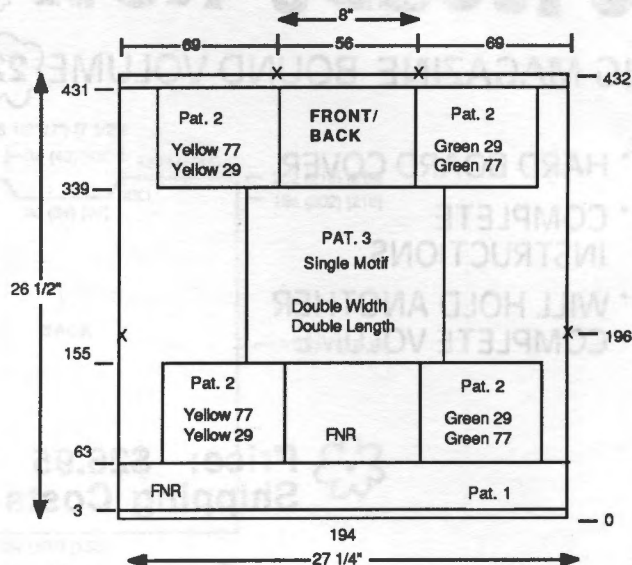
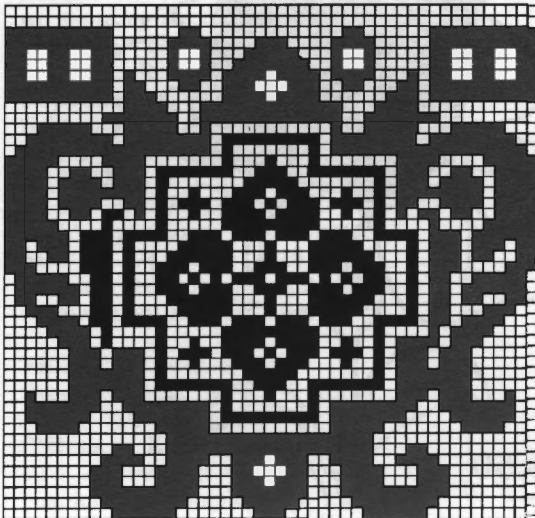



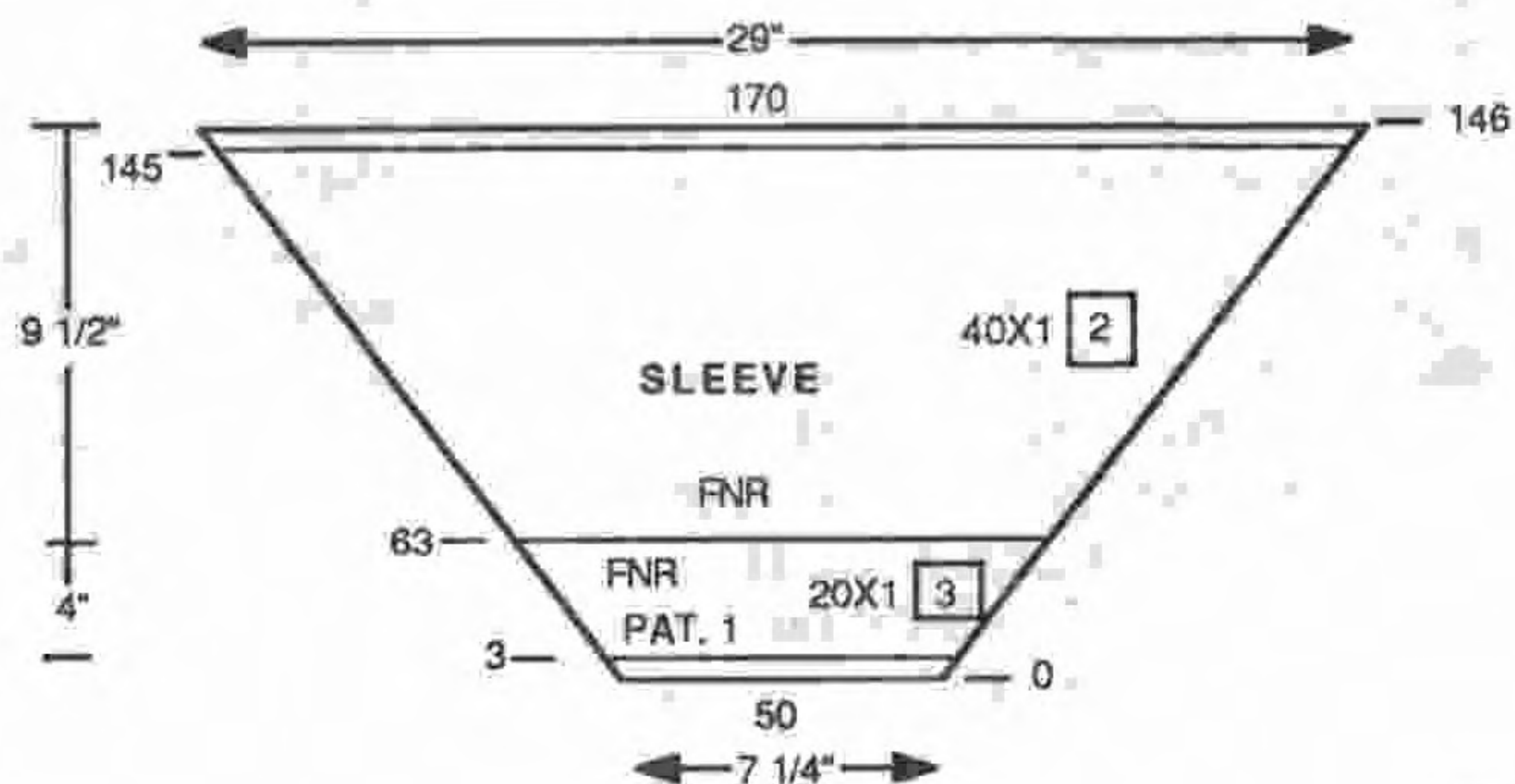
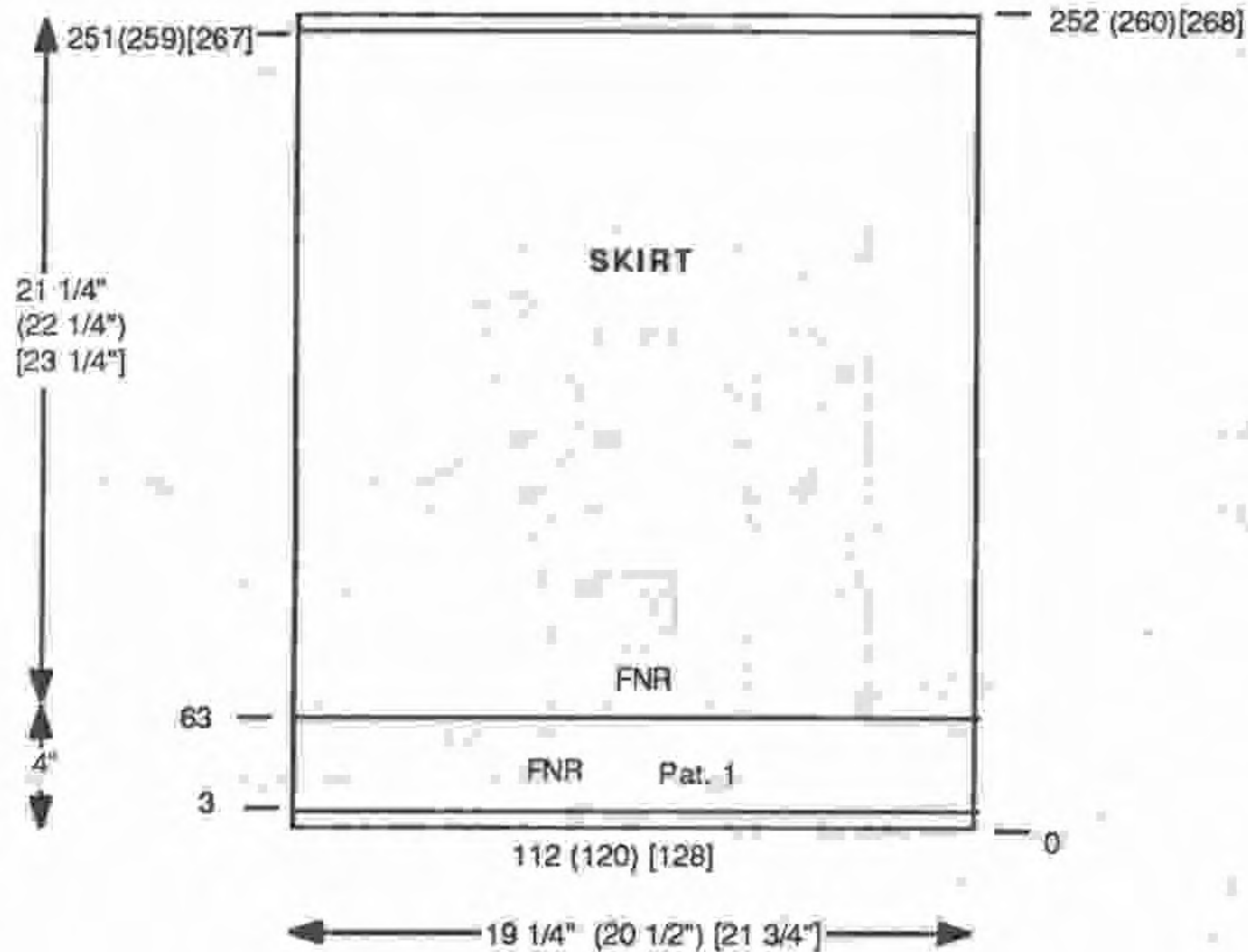

728



**GIRLS CHRISTMAS TREE SWEATER**

**YARN:**

- Col. 1: Silkie - White 1 Cone all sizes
- Col. 2: Mami Rex - Green - 2 spools  
Accent Thread - 2 spools
- Col. 3: Lumiyarn - Gold - 1 spool  
(use 3 strands together)
- Col. 4: Isabella - Red (2 strnds tog.)  
4 balls

**KIT PRICE: \$30.00**

**SIZES: 6/8 10/12**

**TENSION: 7 - RIB; 2/2 II**

**GAUGE: 15 sts. 20 rows = 2" (5 cm)**

**NOTE: THIS PATTERN IS**

AVAILABLE ON THE KNITTING FLOPPY DISK FOR THIS ISSUE. SINGLE MOTIF TREE AND LETTERING ON BACK OF "MERRY CHRISTMAS" AND POINSETTIAS.

Make on the COMPUKNIT III with Ribber. Single Motifs in Fair Isle Designs. Bands are K1, P1 Ribbing.

**BACK:** W.Y. cast on 124 (132) sts. Knit several rows ending with 1 row Ravel Cord to the Right. Counter 0. Change to Col. 1 and continue in St. st After R. 72 (78) mark each side with bit of contrast yarn for setting in sleeves. After R 89 (101) Set Fair Isle Pattern on Track 12- Knit 1 row to set ndls. Use Variation Key No. 1 - Pointsettia Design, with color 1 and 4. When design is completed after 20 rows, knit 3 rows Stockinette stitch with Col. 1 then next pattern will automatically set on same track. Work Fair Isle Pattern with Col. 1 and 3 (10 rows for Merry Christmas- single motif). When design is completed, continue in St. st. to R 150 (160). Bind off the center 54 (58) sts., put the ndls. on the left into HP and complete the right side first. \*SHAPE SHOULDER AND NECK AT THE SAME TIME. For Shoulder, bind off 6 sts. 4x, 7 sts. 1x. (6 sts. 2x, 7 sts. 3x). For neck,

decrease 1 st every 2 rows 4x. Bring the ndls. on the left to WP, turn Row Counter back to 150 (160) and complete the left half following instructions from \*.

**FRONT:** W.Y. cast on the same as for back, 124 (132) sts. After Ravel Cord row, put counter at -0- and with Col 1. knit St. st. to R 3 then Set Fair Isle Design on Track 11 on the next row. Variation Key No. 2 - Single Motif - Col. 1 and Col. 2. Continue in pattern. After R 72 (78), mark each side with bit of contrast yarn for setting in sleeves. After R 126, change to Col. 1 and Col. 3 (Star) (you will

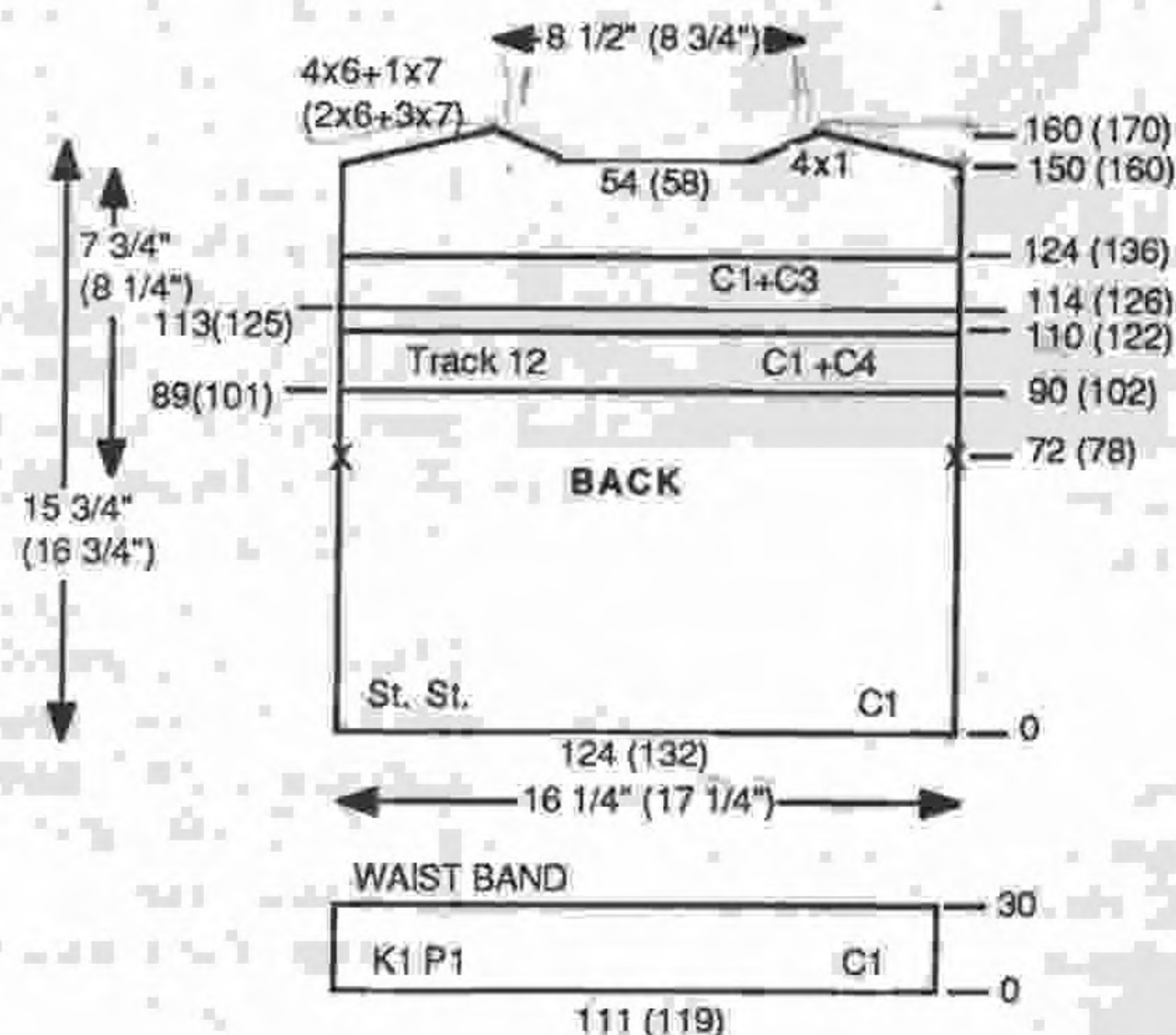

(continued next page)

(continued from previous page)  
 need to duplicate stitch a few rows with green when garment is completed). Star is completed at R 146. Continue in St. st. with Col. 1 to R 150 (160). Bind off the center 54 (58) sts. put the ndls. on the left into HP and complete the right side first. \*SHAPE SHOULDER AND NECK AT THE SAME TIME the same as you did for the back. Bring ndls. on the left to WP, turn Row Counter back to 150 (160) and complete the left half following instructions from \*.

**WAISTBAND:** Make 2. K1, P1 Ribbing. Cast on 111 (119) sts. with color 1 and knit 30 rows. Transfer the rib sts. to MB. Hang the open sts. of back/front onto these ndls. decreasing evenly across. BO loosely.

**NECKBAND:** Close 1 shoulder. K1, P1 Ribbing. With Col. 1, cast on 139 (147) sts. and knit 16 rows. Transfer the rib sts. to MB. Pick up sts. around neckline and BO loosely.

**SLEEVES:** Knit neckband first then close second shoulder.

Bring 120 (128) ndls. to WP. Pick up sts. from mark to mark on front and back and hang onto these ndls. With Col. 1, knit 3 rows St. st. then set Track 2, press the DOWN key to R 20 and press Variation Key 5 and set pattern on next row. Knit with Col. 1 and Col. 4. When pattern is completed (20 rows) stop pattern and continue in St. st. with Col. 1. AT THE SAME TIME, ON EACH SIDE, decrease 1 st. every 4th row 27 (28)x. After R 114 (120) remove the sts. on W.Y.

**SLEEVE CUFFS:** K1, P1 Ribbing. With Col. 1, cast on 57 (61) sts. Knit 30 rows. Transfer rib sts. to MB. Hang the open sts., of sleeve onto these ndls. decreasing evenly across. Bind off loosely.

**FINISHING:** See General Instructions. Work duplicate stitch over top of tree with Green as part of it will be in gold because of star. Trim tree with sequins, beads, tiny figures you can purchase in a craft or needlework store. See Picture.

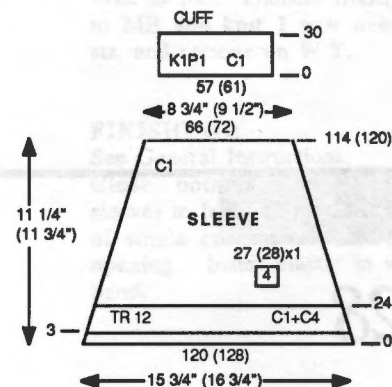
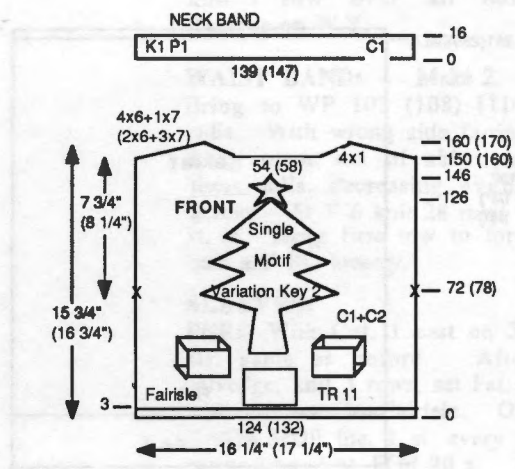

## 729



### BOYS INTARSIA PULLOVER

**SIZES:** 6/8 (10/12)

**YARN:** Amore, Glace, Metallic  
 Col. 1: White Amore - 5balls  
 Col. 2: Black Amore - 1 ball  
 Col. 3: Yellow Amore - 1 ball  
 Col. 4: Tan Amore - 1 ball  
 Col. 4: Red Glace - 1 spool  
 Col. 5: Red Amore - 1 ball  
 Col. 6: Silver Thread -1 spool

**KIT PRICE:** \$25.00

**TENSION:** T7 Intarsia. T6 St. st., T-1/1 I K1, P1 Rib.

**GAUGE:** Intarsia - 15 sts. 28 rows = 2" (5 cm)  
 St. st. 14 sts. 26.5 rows = 2" (5 cm)

Make on any standard machine with Intarsia capabilities and Ribbing Attachment. Send \$1.00 and SASE for enlarged drawing. We used the Intarsia Yarn Brake for uniform tension control.

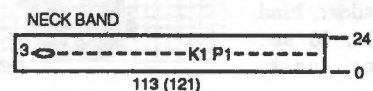

**BACK:** W.Y. cast on 110 (117) sts. Knit several rows ending with 1 row Ravel Cord to the right. Counter 0. Change to Color 1 and work St. st. to R 118 (124). Mark each side with bit of contrast yarn for setting in sleeves. After R 228 (240) bind off the center 30 (33) sts. put the ndls. on the left into HP and complete the right side first. \*SHAPE SHOULDER AND NECK AT THE SAME TIME. For Shoulder, bind off (or use short row method) 9 sts. 4x (9 sts. 2x, 10 sts. 2x) FOR NECK, decrease 1 st. 4x. Bring the ndls. on the left to WP, turn Row Counter back to 228 (240) and complete the left half following instructions from \*.

**FRONT:** INTARSIA TENSION 7. W.Y. cast on 116 (124) sts. After several rows end with 1 row Ravel Cord to the right. Counter 0, change to Col. 1. Knit St. st. to R 8 (14) then follow the Drawing for the Intarsia Design. AT THE SAME TIME, after R 124 (132) mark

each side with bit of yarn for setting in sleeves. After R 26 (238) bind off the center 20 (23) sts. for neck. Put the ndls. on the left into HP and complete the right side first. \*ON NECK EDGE, decrease 1 st. every 2nd row 11 (12)x and at the same time, after R 242 (256), SHAPE SHOULDER, bind off (or use short row method) 9 sts. 3x, 10 sts. 1x. (10 sts. 3x, 9 sts. 1x). Bring the ndls. on the left to WP, turn Row Counter back to 226 (238) and complete the left half following instructions from \*.

**LEFT SHOULDER BANDS:** Close right shoulder first. For the FRONT band, with wrong side facing, pick up 24 (36) sts. beginning at neck edge. (do not stretch these sts. as you will have a part of shoulder to close). Knit St. st. and after R 6, make 2 buttonholes over ndls. 3 and 4 counting from the left and over ndls. 6 and 7 counting from the right. REPEAT the buttonholes over the same ndls.

after R 18. Knit to R 24. Pick up first row of band and hang onto same ndls. BO.  
For the Back shoulder band, with wrong side facing, pick up 24 (36) sts. and work the same as front band but omit the buttonholes.

**NECKBAND:** Close one shoulder first. K1,P1 Ribbing. Cast on 113 (121) sts. with color 1 and work K1, P1 Ribbing. After R 6, make one buttonhole by transferring st. 4 on the right to adjacent ndl on the MB and st. 4 on ribber to adjacent ndl. Leave empty ndls. in work. Knit to R 18 and Repeat the buttonhole. Knit to R 24. Transfer ribber sts. to MB. With wrong side facing, pick up sts. around neckline (including shoulder bands) and hang onto same ndls. BO loosely. Close remaining sts. of left shoulder.

**WAISTBAND:** K1, P1 Ribbing. Make 2. Cast on 111

(119) sts. with col. 1 and work 30 rows K1, P1 ribbing. Transfer rib sts. to MB. With wrong side facing, hang the open sts. of waist onto these ndls. B O loosely.

**SLEEVES:** Bring 116 (123) ndls. to WP. With wrong side facing pick up sts. from marked edges of front and back. Color 1. Work St. st. ON EACH SIDE, decrease 1 st. every 5 rows 28 (29)x. After R 144 (150) remove on W.Y.

**SLEEVE CUFFS:** K1 P1 ribbing. Cast on 53 (57) sts. with color 1 and work 30 rows K1,P1 ribbing. Transfer ribber sts. to MB. With wrong side facing hang the open sts. of sleeve onto these ndls. decreasing evenly across. BO loosely.

**FINISHING:** Sew up sides and sleeves. Finish buttonholes and sew on buttons.

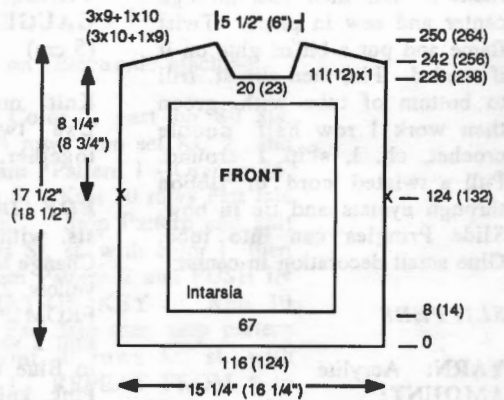
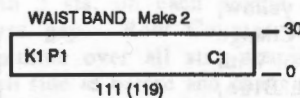
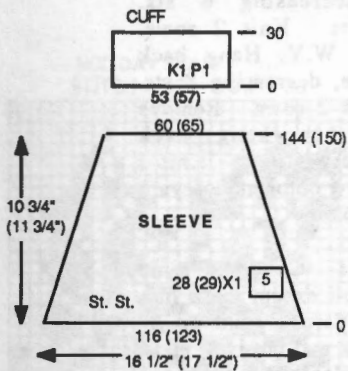
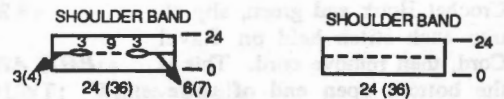
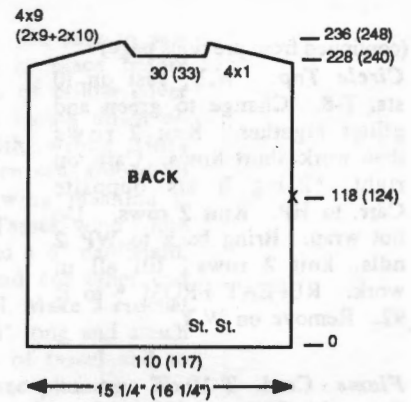

# 730



## HOLIDAY CRAFT ITEMS

### CANDLE

**YARN:** Acrylite  
Color 1 - Red Approx 2 oz.  
Color 2 - Green Approx 1 oz.  
Small amount of thin glitter to add to base frill.  
Small amount orange for flame.  
1 Pringles can with cover  
**TENSION:** 6 on main bed - 5.2 on Ribber  
**GAUGE:** 7.5 sts. 22 rows  
**CIRCULAR** (11 rows MB, 11 rows on Ribber = 1")  
Make on any standard machine with Ribber in FULL NEEDLE CIRCULAR RIBBING.

### Candle:

Half Pitch. Use fine needle bar. Bring 31 needles on MB to WP and 30 ndls. on Ribber to WP. With a Ravel Cord, cast on. Hang Comb and weights, then MOVE PITCH LEVER TO P for circular knitting. Left Part button in on MB, right Part button UP on Ribber. Change to red yarn - T 6 on MB, 5.2 on Ribber. Set Counter to 0 and knit to R 188 (94 rows on each bed). With W.Y. knit circular for 12 rows on each bed. Cut yarn and move carriages across to drop the sts. off machine.

### Frill: Stockinette st. and Short Rows. T-10

W.Y. cast on 20 sts. Knit several rows ending with carriage on the right. Change to green and add fine glitter yarn in same feeder. Knit 2 rows. \*on the left side, bring 18 sts. HP. Knit 2 rows over the 2 needles in work. Do not wrap as hole is part of design. Bring back 2 needles to WP, knit 2 rows until all are in work. REPEAT FROM \* to row 338. Remove on W.Y. Weave open sts. together and remove W.Y.  
(continued next page)

(continued from previous page)

**Circle Top:** W.Y. cast on 10 sts. T-8. Change to green and glitter together. Knit 2 rows then work Short Rows. Carr. on right. \*Bring 8 sts opposite Carr. to HP. Knit 2 rows. Do not wrap. Bring back to WP 2 ndls, knit 2 rows till all in work. REPEAT FROM \* to R 92. Remove on W.Y.

**Flame Cord.** T-10. 'e' cast on 5 sts with Orange. Set machine for knitting a cord. Knit to R 44. BO.

**FINISHING:** With no. 2 Crochet Hook and green, slip st. into each stitch held on Ravel Cord, then remove cord. This is the bottom open end of tube. Slip st. the open end of top of tube with red and remove W.Y. Pin circle top to top. With green slip st. around. Fold flame in half then pull through center and sew in place. Twist flame and put a bit of glue on it if needed. Pin, then slip st. frill to bottom of tube with green then work 1 row half double crochet, ch. 1, skip 1 around. Pull a twisted cord or ribbon through eyelets and tie in bow. Slide Pringles can into tube. Glue small decoration in center.

### SLIPPERS

**YARN:** Acrylite

**AMOUNT:**

Color 1 - 2 oz.

Color 2 - 2 oz.

USE 3 STRANDS YARN TOGETHER

**SIZES:** 9 1/2" - 10" - 11"

To make smaller or larger, increase or decrease 4 sts. and 4 rows.

**TENSION:** Pattern T-3,

Ribbing 3/3 II

**GAUGE:** Fair Isle - Alternate

EON Punch Card - Card on Go

5 sts. = 1", 4 rows = 1"

Same Card on stop. 5 sts. = 1", 4.76 rows = 1"

Make on any Punch Card Bulky machine and be sure to use 3 strands of yarn together.

**K1, P1 Ribbing:** With Color 1, cast on 35 (39) [43] sts. and knit 24 rows. Transfer ribber sts. to MB. Knit 1 row then set Pattern on next row from left to right. Continue in Fair Isle Pattern (You can keep pattern on STOP or use the alternate pattern on GO. Add second color and knit 28 (32) [36] rows. Stop

Pattern and with color 1, knit 1 row then bind off.

**FLOWER:** With 2 strands color 2, cast on 5 sts. T-9. Set machine for knitting a cord.\* Knit 24 rows. Pick up row 1 and hang on end ndl. REPEAT from \* until there are 5 petals. BO. Form petals into a circle and secure.

**FINISHING:** Fold slipper in half and sew up ribbing to beginning of pattern. Sew back seam pulling up at lower heel edge to round it. Attach Flower at instep and make 3 French knots in center with yellow.

### BOY AND GIRL DOLLS

**YARN:** Small amounts of Acrylite in Blue, Pink, Yellow, Grey, Brown or Black. Use left over yarns.

**TENSION:** 2

**GAUGE:** 10 sts. 14 rows = 2" (5 cm)

Knit on any Bulky machine. Use two strands of yarn together.

**BOY DOLL:** 'e' cast on 38 sts. with grey. Knit 6 rows. Change to yellow. \*Knit 2 rows yellow, 2 rows Blue and REPEAT FROM \* 3x more. With yellow, knit 2 rows (row 24). Change to Blue and knit 14 rows. With Pink, knit 10 rows. With Blue, knit 1 row. Reverse the knitting, knit 1 row. Reverse the knitting, knit 2 rows. With yellow, knit 4 rows. With blue, knit 4 rows. Remove on W.Y. Hang the sts. back onto machine, decreasing 6 sts. evenly across (4th then every 5th, 2 sts. on ndl.) With yellow, knit 2 rows. Remove on W.Y. Hang back onto machine, decreasing 6 sts. across as before. With blue, knit 2 rows. Remove on W.Y. Hang back onto machine with 2 sts. on each ndl. 14 sts. With yellow, knit 2 rows. Thread tapestry ndl. and remove the sts. onto end of yarn and pull up.

**FINISHING:** Fold so that seam will be in center back and weave or sew up seam. Stuff with Polyester Fiber Fill (not too tight) With pink make a running st. around neck and pull up tightly to form head. Sew down center through body from top of pants to feet then on each side form arms by sewing from

shoulder to pants. Close feet. Make tiny pom-pon for top of hat and sew in place. Make Scarf with yellow. Cast on 3 sts. T-4. Push in Right Part Button and knit to Row 90. Bind off but leave enough to form a fringe at ends. Embroider eyes and mouth (See Picture)

### GIRL DOLL

Same yarn and tension as for Boy Doll - Use two strands of Acrylite on Bulky machine.

With Black 'e' cast on 38 sts. With tension 1, knit 6 rows (shoes) With Red Tension 2, knit 10 rows. Put every 2nd ndl. in HP and with white Angora or mohair, and tension 4, knit 2 rows. With red, Tension 2, knit 2 rows. With white knit 10 rows, setting pattern from left to right on 10th row. Knit in Fair Isle Pattern with red and white for 8 rows. Change to pink and st. st. Knit 10 rows. Remove onto W.Y. Hang back onto machine, decreasing 6 sts. evenly across. Knit 2 rows. Remove on W.Y. Hang back onto machine, decreasing 8 sts. across. Knit 2 rows. Remove on W.Y. then hang back doubling every stitch. Knit 1 row. Remove onto end of yarn as for boy doll.

**FINISHING:** Complete same as for boy doll except make hair by winding yarn around an 8" cardboard 20x and cut both ends. Sew this in place to form bangs and back hair, then wind yarn around 8" cardboard approx. 60x, tie in center and cut one end. Sew to top of head. Trim hair (see picture).

Slipper Pattern Card

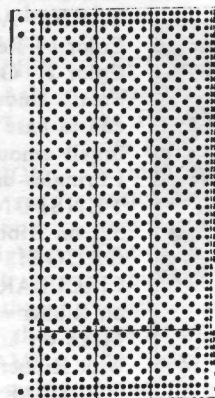

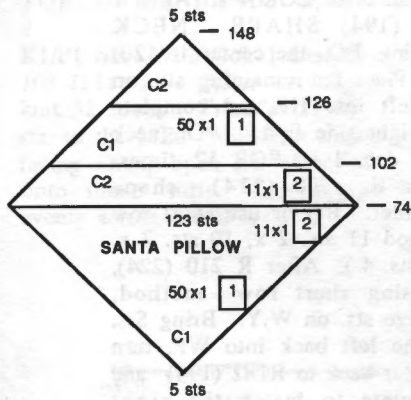

**BACK SLIT**

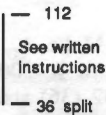

**HOLIDAY SCARF**  
STITCH = 32 ROW = 30

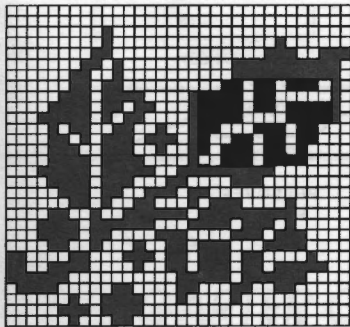

**SANTA PILLOW COVER**

**YARN:** Acrylite  
**AMOUNT:**  
Color 1 Red - 4 oz.  
Color 2 White - 2 oz.  
Small amount Black  
**TENSION:** 6 Stockinette st.  
**GAUGE:** 16 sts. 18 rows = 2"  
(5 cm)

Make on any standard machine.  
Can also be used as a Pajama Bag for a small child.

**IMPORTANT NOTE:** WHEN decreasing on EVERY ROW, on Carriage side, knit the end st. by hand then allow that st. to knit again. This prevents the edge being too tight. When

increasing, you only need to bring a new needle to working position or HP and it automatically casts on. **FRONT:** Make 1 'e' cast on 5 sts. with White. ON EACH SIDE, increase 1 st. EVERY ROW 50x then 1 st. every 2nd row 1lx. After R 74, change to Red. ON EACH SIDE, decrease 1 st. every 2nd row 1lx, then EVERY ROW 50x BUT AT THE SAME TIME, after row 102 change to White and after R 126, change to Red. After R 148, bind off the 5 remaining sts.

**BACK:** The back is made the same as front with exception of the split for back opening. After R 36, divide in the center and remove the sts. left of 0 onto W.Y. Cast on 8 sts. left of center for facing. Continue knitting but remember to change color on same rows as front. After R 112, remove the sts. on W.Y. Hang the left side back onto machine and cast on 8 sts. to the right of 0. Row counter back to 36. Knit to match the right half. After R 112, remove 8 sts. on the right and fold over onto 8 sts. (facing). Hang the right side held on waste yarn onto the machine with the 8 sts. of under facing onto the 8 sts. There will be 8 sts. in center with 3 sts. on each needle to close gap. Row Counter 112. Continue over all sts., shaping each side as before and changing color on established rows. After R 148, BO.

**TRIM:** T-8. With white, 'e' cast on 5 sts. Knit 2 rows. \*Put 2 ndls. on the left into HP and knit 12 rows over the 3 ndls. in work. All ndls. in work, knit 4 rows. REPEAT FROM \* to R 688. BO.

**EYES & NOSE:** Open cast on 34 sts. with red yarn. Knit 30 rows. Knit a few rows W.Y. then change to black. Knit 30 rows. Knit a few rows with waste yarn then remove from machine. Steam this piece then press some light weight Stitch Witchery on the purl side. With a pencil, mark a 1 3/4" diameter circle on the wrong side, one in red, one in black then cut out. Cut the black one in half and sew in place for eyes. Sew nose in place (see picture for placement). You can zig-zag around using a small stitch on sewing machine and with matching thread.

**FINISHING:** Be sure to sew eyes and nose in place before sewing sections of pillow cover together. Sew facing down on opening. With wrong sides together, pin then sew around all sides using sewing machine if you like. For Tassel, wind white yarn 60x around a 6" cardboard. Tie one end and cut other end and make tassel. Make a crochet chain approx. 6" long and attach one end to tip of tassel and to pillow cover (see picture). For whiskers, wind white yarn 60x around 6" cardboard. Tie one end, cut other end. Sew in place beneath nose.

**SCARF:**

**YARN:** Amore  
**AMOUNT:** White: 2 balls  
Red: 2 balls  
**KIT PRICE:** \$9.00  
**TENSION:** 6  
**GAUGE:** 26.5 R, 14 sts. = 2"  
(5 cm.)

Make on Electronic machine.

With Color 1, cast on 80 sts. Knit 3 rows then set KC 2 and program \*Pattern 1 - Orange 36, Green 5. Knit 30 rows Fair Isle pattern. Stop Pattern and knit 9 rows St. st. with color 1 then program Pattern 2 and PUSH IN VARIATION KEY 1. Knit 30 rows Fair Isle then stop pattern and knit 10 rows St. st. with color 1. REPEAT FROM \* to Row 478 ending with 4 rows St. st. instead of 10.

**FINISHING:** Fold scarf in half and sew up side seam. Cut fringe 8 inches long. Use 4 strands of yarn, fold in half and make fringe across each end of scarf. See picture.

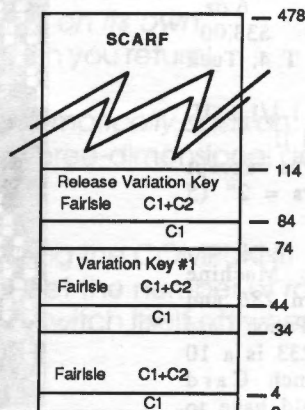



STITCH = 10  
ROW = 14

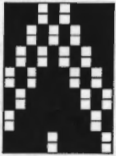

PATTERN 233  
FROM COMPUKNIT III  
PATTERN BOOK

STITCH = 8  
ROW = 8



PAT. 286  
COMP III  
PAT. BOOK

## GIRLS 3 PC. OUTFIT

**YARN:** Roma  
Col. 1 Royal Blue  
Col. 2 White  
Col. 3 Lilac

**SIZES:** 6/6x (8)

**AMOUNT:**

Col. 1	16 oz.	16 oz.
Col. 2	4 oz.	5 oz.
Col. 3	5 oz.	6 oz.

**KIT PRICE:** \$29.50 \$33.00

**TENSION:** St. st. T 4, Tuck

St. Pattern T 5.

Waist Band Rib - 1.1/1.1 II,

Neck Band Rib - T 1/1 II

**GAUGE:** All patterns except  
rib - 14 sts. 29 rows = 2" (5  
Cm)

Make on Electronic Machine  
with Ribber. Pattern 286 and  
304 are adaptable to Punch Card  
machines, but Pat. 233 is a 10  
st. pattern, and Punch Card  
machine owners would have to  
substitute a suitable pattern.

### NOTE:

The purl side is the right side.  
Since these are Tuck st. patterns,  
the pattern has a tendency to  
pucker together. In order to get  
a nice straight stitch line  
between St. St. and Tuck st.  
patterns **ALWAYS START TUCK  
ST. PATTERN WITH 2 ROWS  
STOCKINETTE ST.** (Setting Tuck  
Stitch pattern on the second  
row) and **ALWAYS CANCEL  
TUCK ST. PATTERN 2 ROWS  
BEFORE STARTING THE NEXT  
PATTERN.** This gives a smooth  
straight row between patterns.

Make a sample swatch for  
pattern #286. This has needles  
out of work. It is best to mark  
the needles that are out of work  
on the needle bed. This way,  
when you come to this pattern  
in the sequence you know  
exactly which needles to transfer  
and take out of work.

PAT. 286 USES KC II setting.

**SHORT ROWS:** Be sure to  
always wrap inside needles in HP  
when knitting short rows.

**TOP FRONT:** Make 1.

W.Y. cast on 108 (116) sts.  
After several rows, end with 1  
row Ravel Cord to the right.  
Change to Col. 2 and knit 4  
rows. Change to Col. 1 and  
knit 2 rows st. st. setting Tuck  
st. Pattern 233 on second row.  
After R 46 (50) cancel pattern  
and knit 2 rows st. st. (See  
note). After R 48 (52) Change  
to Col. 3 and knit 4 rows.  
Change to Col. 2 and set Pat.  
286. Knit in Tuck st. to R 128  
(136). Change to Col. 1. Knit

STITCH = 24 ROW = 48

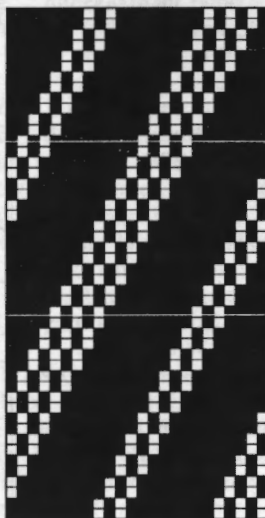

PAT. 304 FROM COMP III PAT. BOOK

4 Rows. Change to Col. 3, set  
Tuck st. pattern. On each side  
cast on 2 sts. EOR 4 x. After R  
182 (194) SHAPE NECK  
opening. BO the center 16 (20)  
sts. Place the remaining sts. on  
the left into HP and complete  
the right side first. \*On neck  
edge dec. 1 st. EOR 12 times.  
After R 200 (214) shape  
shoulder. BO or use short row  
method 11 sts. 2 x, 10 sts. 2 x,  
(11 sts. 4). After R 210 (224),  
if using short row method,  
remove sts. on W.Y. Bring Sts.  
on the left back into WP, turn  
counter back to R182 (194) and  
complete to match the right  
side. Follow instructions from  
\*.

**TOP BACK:** Make 1.

Same as Front to R 200 (214).  
BO the center 32 (36) sts. Place  
remaining sts. on the left into  
HP and complete the right side  
first. Shape neck opening and  
shoulders at the same time.  
Shape shoulders, same as Front.  
On neck edge dec. 1 st. EOR 4  
x. After R 210 (224), if using  
short row method BO or remove  
remaining sts. on W.Y.

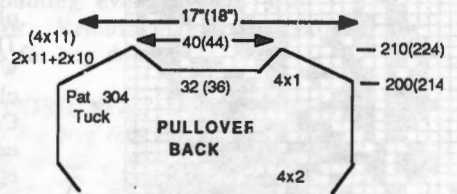

**TOP NECK BAND:**

Make 1. Close one shoulder  
first.

K1/P1 rib: With Col. 3 cast on  
137 (145) sts. After selvedge,  
knit 32 rows. Transfer Rib sts.  
to Main Bed. Pick up first row  
to form hem. Knit 1 row over  
all sts. With wrong side  
facing, hang neck opening onto  
these ndls. and BO.

PULLOVER SLEEVE BAND

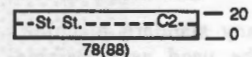

NECK BAND

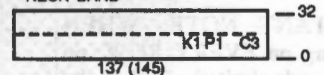

**TOP WAIST BAND:** Make 2.

**K1/P1 rib:** With Col. 1 cast on 103 (111) sts. After selvedge knit 32 rows. Transfer ribber sts. to the MB. With knit side facing, hang open sts. of waist onto these ndls. decreasing evenly across and BO.

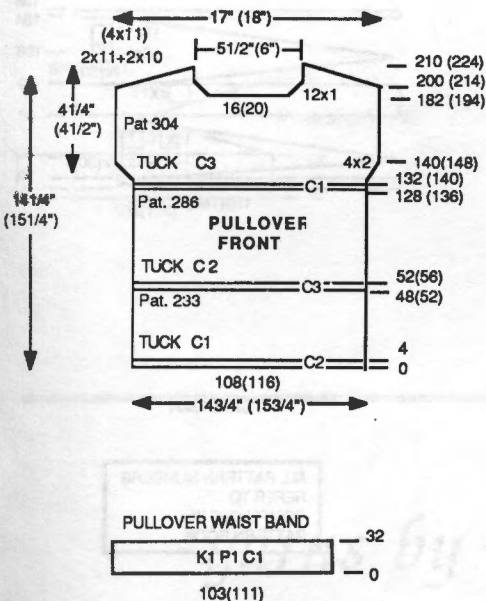

**CARDIGAN BACK:**

Make 1 - Knitted sideways  
 W.Y. cast on 113 (121) sts. same as before. Change to Col. 1 and knit 4 rows. Change to Col. 2. Set Tuck st. Pat. 286 and knit to row 68 (72). Change to Col. 3. Knit 4 rows. Change to Col. 1. Set Tuck St. Pat. 304 and continue in pattern. BUT AT THE SAME TIME, on the neck edge dec. 1 st. EOR 5 x. After R 112 (118) Change to Col. 2 and knit 4 rows st. st. After R 116 (122) change to Col. 3. Set Tuck st. Pat. 304. BE SURE TO PRESS VARIATION KEY NO. 1. TO REVERSE

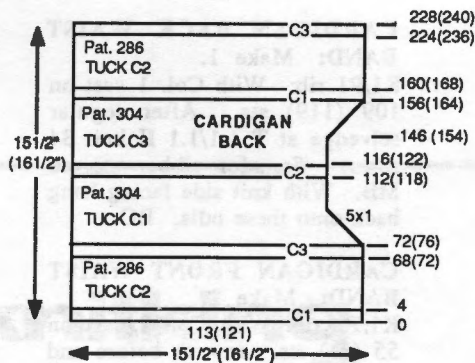

**PATTERN.** After R 146 (154) on neck edge inc. 1 st. EOR 5 x. After R 156 (164). Change to Col. 1 and knit 4 rows. st. st. Change to Col. 2, set Tuck St. pattern 286 and knit to R 224 (236). Change to Col. 3 and knit 4 rows st. st. Remove on W.Y.

**CARDIGAN FRONT:**

**Left Front:**

W.Y. cast on 113 (121) sts. same as before. Change to Col.

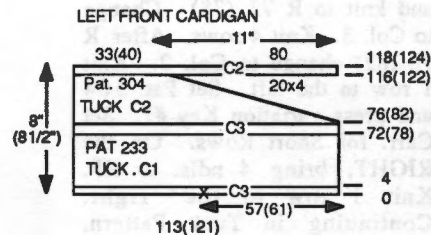

(continued next page)

**THE GARTER CARRIAGE KNITS RIBBING AUTOMATICALLY AND MUCH, MUCH MORE!!**

The KnitKing Garter Carriage makes knitting Ribbing a breeze. With the press of a button, the Garter Carriage moves across your knitting machine *on its own power!* You can leave the room and your ribbing will be finished when you return!

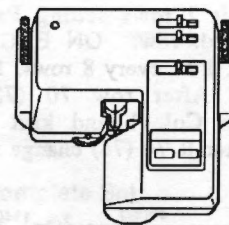

But ribbing is only the beginning of the story: The Garter Carriage *automatically casts on, binds off and knits a multitude of fancy Garter Stitch patterns*—beautiful textured three-dimensional designs impossible to knit any other way.

You merely select your desired pattern on your knitting machine (using the COMPUKNIT III keyboard, the COMPUKNIT II mylar sheets, or the KH 860 - KK 93 punch cards), set the number of rows needed, switch your Garter Carriage on, and leave to do other things. It will switch itself off when a garment section is completed or if the yarn runs out or breaks.

Order your Garter Carriage now from your local KnitKing dealer, or if you do not have one in your area, order direct from KNITKING, 1128 Crenshaw Blvd., Los Angeles, CA 90019. Phone: 213-938-2077.

(continued from previous page)

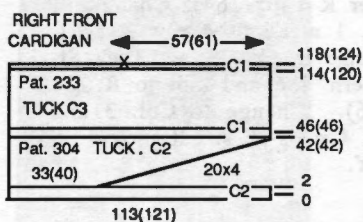

3. Knit 1 row to the left. Mark with W.Y. ndl. 57 (61) for armhole. Knit to R 4. Change to Col. 1. Set Tuck Pattern 233 and knit to R 72 (78) Change to Col. 3. Knit 4 rows. After R 76 (82) change to Col. 2. Knit 1 row to the left. Set Pat. 304 and press variation Key #1. Set Carr. for Short Rows. On the RIGHT, bring 4 ndls. to HP. Knit 1 row to the right. Continuing in Tuck Pattern, bring 4 ndls. to HP every 2nd row 19x more. After R 116 (122) change to Col. 2, all ndls. in work. Knit 2 rows st. st. After R. 118 (124) BO.

*Right Front:*

Reverse shaping.

For short rows. Carr. is on the left. 80 ndls. on right in HP. Push back to WP the 4 inside ndls. EOR for a total of 20 x.

**DO NOT use Variation key 1 for pattern 304.**

**CARDIGAN SLEEVES:**

W.Y. cast on 112 (120) sts. same as before. Change to Col. 3 and knit 2 rows setting Pat. 286 on 2nd. row. ON EACH SIDE dec. 1 st. every 8 rows. 13 (14) x. After row 70 (72) change to Col. 1 and knit 4 rows. After R 74 (76) change to

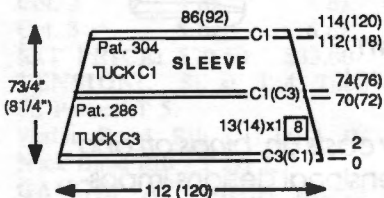

Col. 1. Knit 2 rows setting pat. 304 on 2nd row. After R 112 (118) change to Col. 1 and knit 2 rows. Remove on W.Y.

**2ND. SLEEVE**

Same as before but NOTE COLOR CHANGES ON ROW -0- AND ROW 70 (72). SEE CHART.

**CARDIGAN SLEEVE**

**CUFFS:**

Make 1 with Col. 1 and 1 with Col. 3.

W.Y. cast on 84 (90) sts. same as before. Change to Col. 1 (Col. 3) and knit 70 rows. Pick up first row to form hem. With Knit side facing, hang open sts. of sleeve onto these ndls. decreasing evenly across. BO.

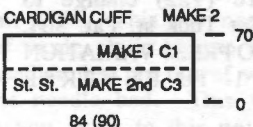

**CARDIGAN BACK WAIST**

**BAND: Make 1.**

K1/P1 rib: With Col. 1 cast on 109 (119) sts. After regular selvedge at T 1.1/1.1 II knit 34 rows. Transfer ribber sts. to MB. With knit side facing hang back onto these ndls. BO.

**CARDIGAN FRONT WAIST**

**BAND: Make 2.**

K1/P1 rib: With Col. 1 cast on 55 (61) sts. same as before and knit 34 rows. Transfer ribber sts. to MB. With knit side facing hang front section onto these ndls. and BO.

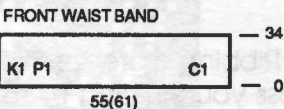
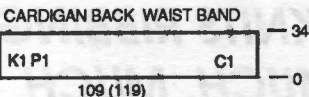

**CARDIGAN NECK BAND:**

**Make 1, Reverse 1.**

Close BOTH shoulders of Cardigan.

W.Y. cast on 152 (160) sts. same as before. After several rows knit Ravel Cord row. Change to Col. 2. Knit 2 rows. Carr. on the right. On the right side leave 30 ndls. in WP. Bring the balance to -E- or HP. Set carr. for short rows. Knit 1 row to the left. Wrap inside needle to avoid holes. Knit 1 row to the right. On the carriage side push back to WP

10 ndls. EOR 13 times. Row 30. Carr. on the right. On same side as carr. bring 10 ndls. to HP every other row 13 x. After R 56 knit 24 rows st. st. and repeat through R 136. See Chart. BO.

Fold lengthwise, starting at center of back neck, sew or weave to neck opening.

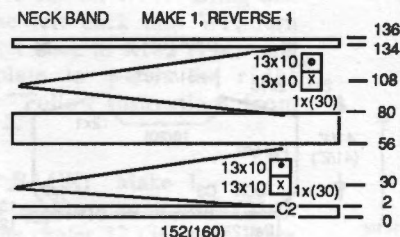

CARDIGAN

ALL PATTERN NUMBERS REFER TO COMPUKNIT III PATTERN BOOK



**SKIRT:** Make 1. Made sideways.

W.Y. cast on 106 (114) sts. After Ravel Cord row change to Col. 1 and knit 11 rows. Carr. on left. \*On opposite side of carriage (right) bring to HP 5 sts. EOR 11x. Bring back to W.P. 5 sts. EOR 11x. Repeat from \* 29 (31) x more. Remove on W.Y.

**SKIRT WAIST BAND:** Make 2.

Join side seam of skirt. (Weaving is the best method.) W.Y. cast on 78 (84) sts. same as before. Change to Col. 1. Knit 30 rows. Pick up first row to form hem. With purl side facing, hang 1/2 of skirt waist onto these ndls. BO. Repeat for second half of skirt waist. Insert elastic and close side seam.

**SPECIAL NOTE:**  
All small striped sections of 2 rows each should be knitted in stockinette stitch.

**FINISHING:**  
See General instructions.

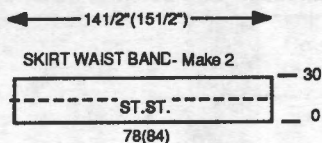
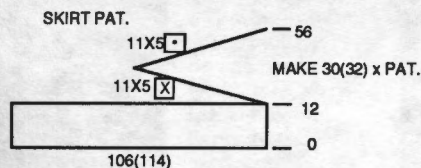

## yarns by **knitking**

The finest quality KNITKING yarns are used to create the beautiful fashions found in KNITKING Magazine. Kit prices are located with the instructions for each garment. Each yarn comes in a wide selection of colors. The different types of yarns have been selected to allow for blending, mixing, and contrasting—both color and texture. Color cards are available through KNITKING or an authorized Knitking dealer.

Content and approximate yardage is included in the chart below:

	<i>Yds./Pound</i>
Amore _____ 100 % Acrylic (50 gr. ball)	245 yds/ball
Angora _____ 100% Rabbit Hair (10 gr. ball)	33 yds/ball
Acrylite _____ 2/12 Acrylic	2400
Bulkytime _____ 100% Bulky Orlon with slubs	1500
Caprinae _____ 78% Mohair/13% Wool/9% Nylon	980
Glance _____ 100% Slinky Bright Rayon	2400
Ice Cream _____ 54% Cotton/46% Rayon	1700
Kotton _____ 100% Cotton	2200
Lumiyarn _____ Thin Metallic Yarn (50 gr. cone)	3500
Nordic _____ 100% Australian Wool	1650
Pearlyte _____ 100% Rayon Boucle	2200
Pebble _____ Boucle Cotton/Acrylic/Rayon	700
Primo _____ 100% Mercerized Cotton	2500
Roma _____ 80% Acrilan/20% Antron	2600
Rubane (50 gr ball) 100% Polyamid 1/8" ribbon	82/ball
Silkie _____ 2-Ply Orlon	2100
Starlite _____ Acrylic w/Metallic Thread	2400
Venetia _____ 70% Wool/30% Rayon	2400

**Complete Set  
of  
Color Cards:  
Only \$12.00**

# Knitkng Sizing Chart

## MISSES

Size	6	8	10	12	14	16	18
Bust	30 1/2	31 1/2	32 1/2	34	36	38	40
Waist	22	23	24	25 1/2	27	29	31
Hip	32 1/2	33 1/2	34 1/2	36	38	40	42
Back Waist Length	15 1/2	15 3/4	16	16 1/4	16 1/2	16 3/4	17
Shoulder to Shoulder	13 1/2	13 1/2	14	14 1/2	15	15 1/2	16
Armhole Depth	7	7	7 1/2	7 1/2	7 1/2	8	8
Sleeve Length Under Arm	16 1/2	16 1/2	17 1/2	17 1/2	17 1/2	18	18

*These are actual body sizes. Proper ease allowance is necessary as determined by the style.*

## WOMENS

Size	38	40	42	44
Bust	42	44	46	48
Waist	34	36	38	40 1/2
Hip	44	46	48	50
Back Waist Length	17 1/4	17 1/2	17 1/2	17 3/4
Shoulder to Shoulder	16 1/2	17	17 1/2	18
Armhole Depth	8 1/4	8 1/4	8 1/4	8 1/2
Sleeve Length Under Arm	18 1/2	18 1/2	18 1/2	18 1/2

*These are actual body sizes. Proper ease allowance is necessary as determined by the style.*

## CHILDREN

Size	12 mo	2 yr	4	6	8	10	12
Chest	19	21	23	25	27	28	30
Waist	19	20	21	22	23	24	25
Hip	20	22	24	26	28	30	32
Back Waist Length	7	8 1/2	9 1/2	10 1/2	12 1/2	14	15
Shoulder to Shoulder	7 1/2	8 1/2	9 1/2	10	11	11 1/2	12
Armhole Depth	3 1/2	4	5 1/2	6	6 1/2	6 1/2	7
Sleeve Length Under Arm	6	7 1/2	9 1/2	10 1/2	12	13 1/2	15

*These are actual body sizes. Proper ease allowance is necessary as determined by the style.*

## Mens

Size	34	36	38	40	42	44
Chest	34	36	38	40	42	44
Waist	30	32	34	36	38	40
Hip	35	37	39	41	43	45
Back Waist Length	15 1/2	15 1/2	16	16 1/4	16 1/4	16 1/4
Shoulder to Shoulder	15 1/2	16	16 1/2	17	17 1/2	18
Armhole Depth	8	8 1/2	9	9 1/2	10	10 1/2
Sleeve Length Under Arm	19	19 1/2	19 1/2	20	20	20 1/2

*These are actual body sizes. Proper ease allowance is necessary as determined by the style.*

# The First Complete Machine Knitting Videotape Course with Instruction Manuals

This professionally-produced Video Course, featuring industry-rekowned Jan Wold, offers insight and instruction on the broadest range of techniques and knitting machine accessories. The accompanying Instruction Manuals allow you to follow along in the "written word", if you prefer. But whether you watch, read, or do both, this course is sure to make you a better machine knitter—regardless of your level of expertise!

## BASIC MACHINE KNITTING

Fundamentals of machine knitting including machine parts, multiple cast-on and bind-off techniques, shaping techniques, hems, necklines, swatches; *Includes making a pullover from start-to-finish; much more!*

75 MIN. \$54.95

## PUNCHCARD/ELECTRONIC PATTERNING

Get to know the full capabilities of texture and technique. Master the major patterning techniques (Fair Isle, Lace, Weaving, Tuck, etc.); 4-Color Changer; Disk Drive; Pattern Design Computer—a course by itself.

110 MIN. \$54.95

## RIBBER/GARTER CARRIAGE

These accessories open a new spectrum into machine knitting. Learn Double Jacquard (a favorite of the pricey fashion designers!); fancy rib stitches; tubular knitting; Ribber 4-Color Changer; Garter Carriage cast-on, pattern stitches and more.

55 MIN. \$49.95

## KNITLEADER CALCUKNIT/ADVANCED TECHNIQUES

You've got the basics down pat now—time to learn Intarsia knitting, Short Rows, Cords, Cables, Charting with your Calcuknit Knitting Calculator and more—The sky is the limit!

60 MIN. \$49.95

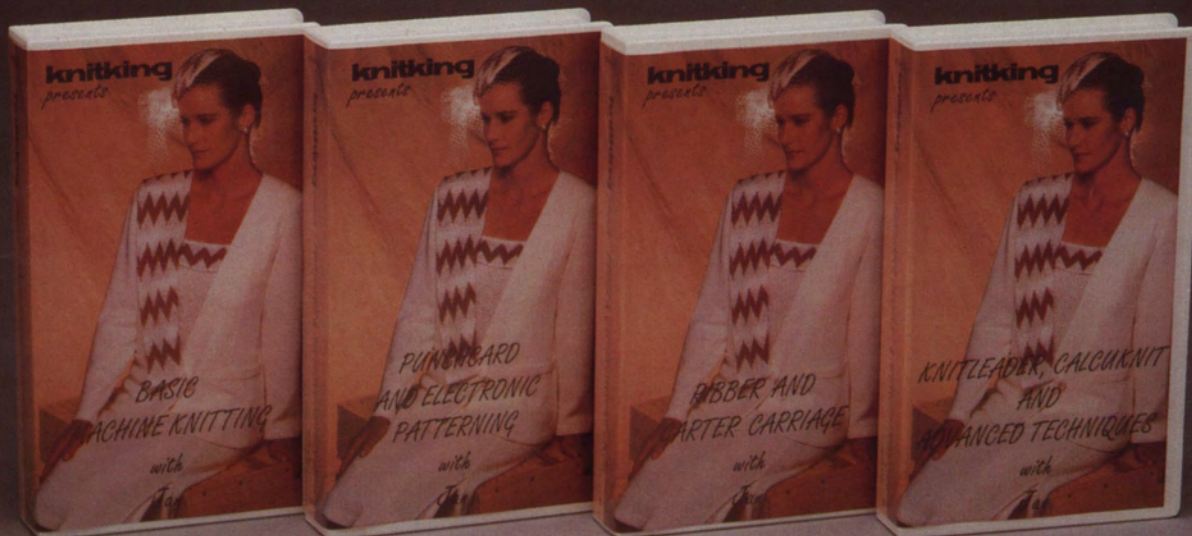

**Save \$40.00 by ordering the complete course of 4 Tapes and Manuals for only \$169.95!**

Order VHS or Beta format tapes individually or as a set from your local KNITKING Dealer.

If you do not have a KNITKING Dealer in your area, you may order from:

## knitking

Where Savings And Value  
Are Always In Fashion

1128 Crenshaw Blvd., Los Angeles, CA 90019 (213) 938-2077



# Gracious

## 722

...and too lovely to pass up. It is styled for just about everyone. The slim Skirt is Stockinette stitch, the sleeveless Pullover a gorgeous Fair Isle design and you top it all with the flowing Cocoon cover-up for the perfect flattering trio. Knit it on a standard or Electronic machine with our shining Pearlyte.

# A Standard Knit Cardigan

## 723

...becomes outstanding if you knit it in a bold Houndstooth plus a zig-zag Fair Isle design on the front and back. It's knitted on an Electronic machine with Ribber or you can use your Garter Carriage for the bands. The yarn is Roma.

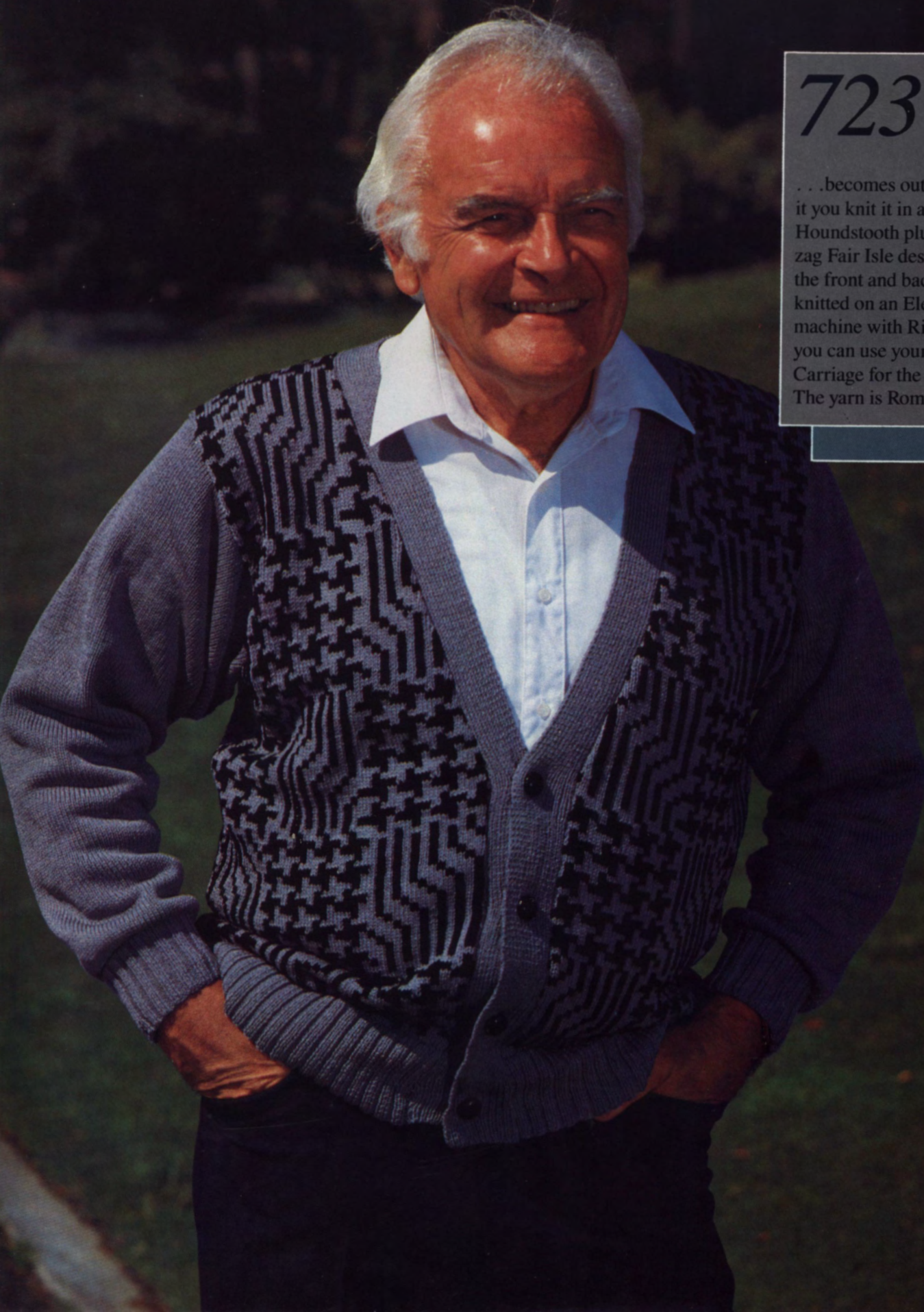

# Designer Original

## 724

A mock turtle neck Pull-over is knitted in panels and worn on the purl side. The bands are ribbed and large buttons trim the neckband. Sleeves are full and are partly knitted with Starlite then Pebble. Center sections are Starlite, panels are Pebble. Bands are ribbed. Knit it on a Bulky Machine with Ribber.

Made  
To  
Order

725

The newest of Thread Lace designs knits up quickly into a soft and luxurious Pullover for the man in your life. He'll enjoy the warmth and extra good looks. A special order Kit for this one. The yarn is a wool and angora blend. It's knitted on the Bulky Machine with a ribbing attachment.

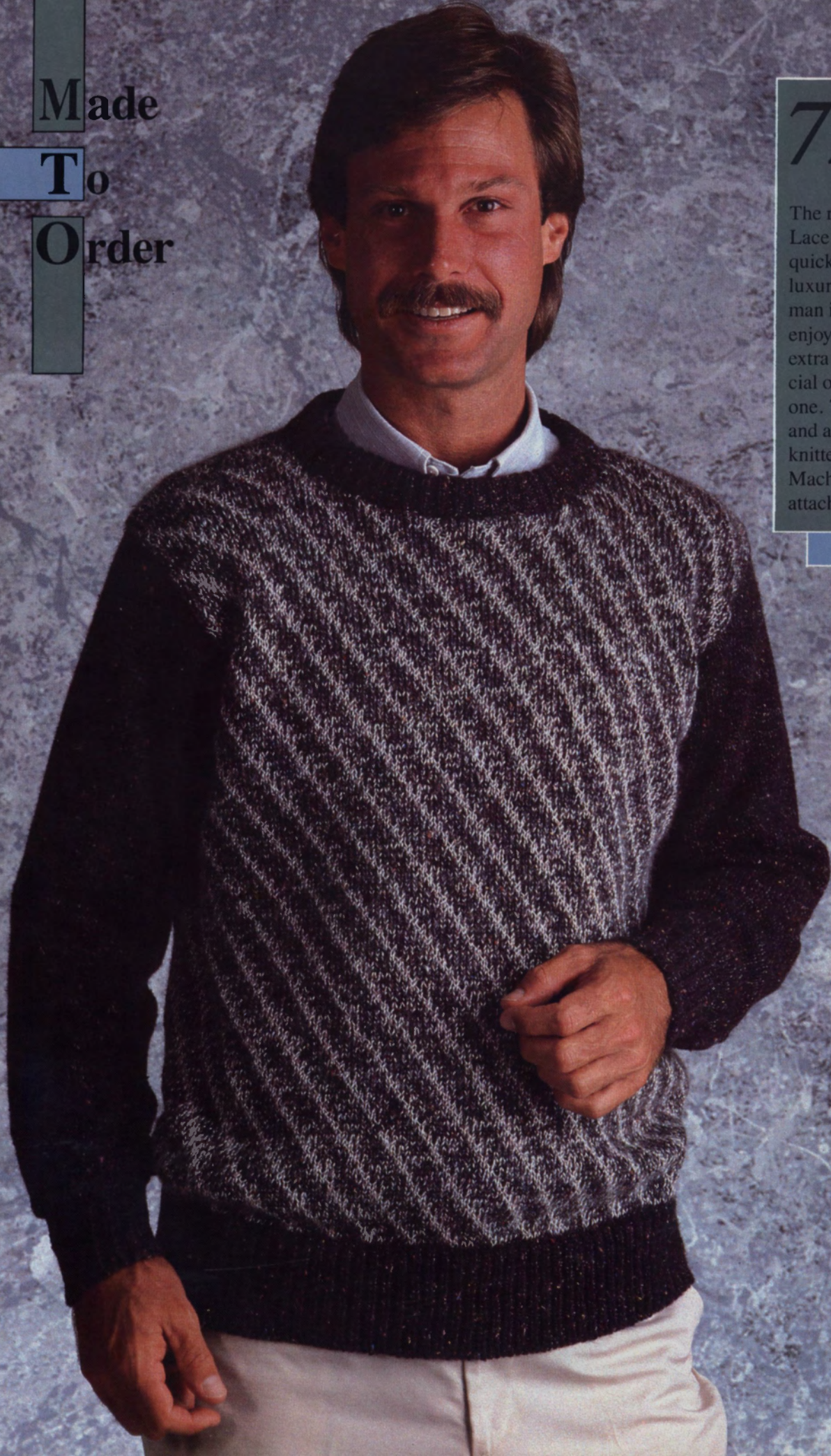

# The **T**urtle **T**riumphs

## 726

...again and again. A warm winter white Sweater is knitted on the COMPUKNIT III with Garter Carriage. Fringe is used for accents on the bodice, shoulder and ribbed Collar and Sleeve cuffs. A Teens delight; to be knitted with our machine wash and dry Acrylite.





# Big and Beautiful



## 727

A stunning oversized Top flows softly over a slim Skirt. Wear it to any Holiday party and watch heads turn. The Skirt and sleeve Cuffs are bordered with a Fair Isle Design and the large isolated Design on the front of Top is absolutely gorgeous. Knit is on the COMPUKNIT III with Acrylite.

# The Children's Hour



728 &  
729

...begins with bright Pullovers that are knitted in the Christmas spirit. Knit her Sweater on the COMPUKNIT III that isolates a large Christmas Tree on the front, Pointsettia border on the sleeves, then a surprise bonus across the back greets you with "Merry Christmas." His sweater: Mr. Penguin lines up for the big home run hit, a large Intarsia Design.

# Holiday Gifts



## 730

Slippers, Dolls, Candle Decoration, Scarf and a Shades of Picasso Pillow Cover (or Pajama Bag) are all fun to knit and will make great gifts. The Slippers and Dolls were knitted on a Bulky machine; Scarf, Candle Decoration and Pillow Cover on Standard machine. A Ribber is needed for circular knitting on the Candle Decoration. Knit all but Scarf using Acrylite.

# Triple Her Delight

## 731

...with a three piece ensemble that any young girl will adore. The Skirt is knitted sideways on the machine in stockinette stitch using short rows, then top it with a tuck stitch Pullover and matching Jacket. Roma is the yarn (for wash and wear) and you knit it on any standard Punch Card or Electronic machine.



# Now You Can Knit Your Garments in the Wink of an Eye and the Tap of a Foot!

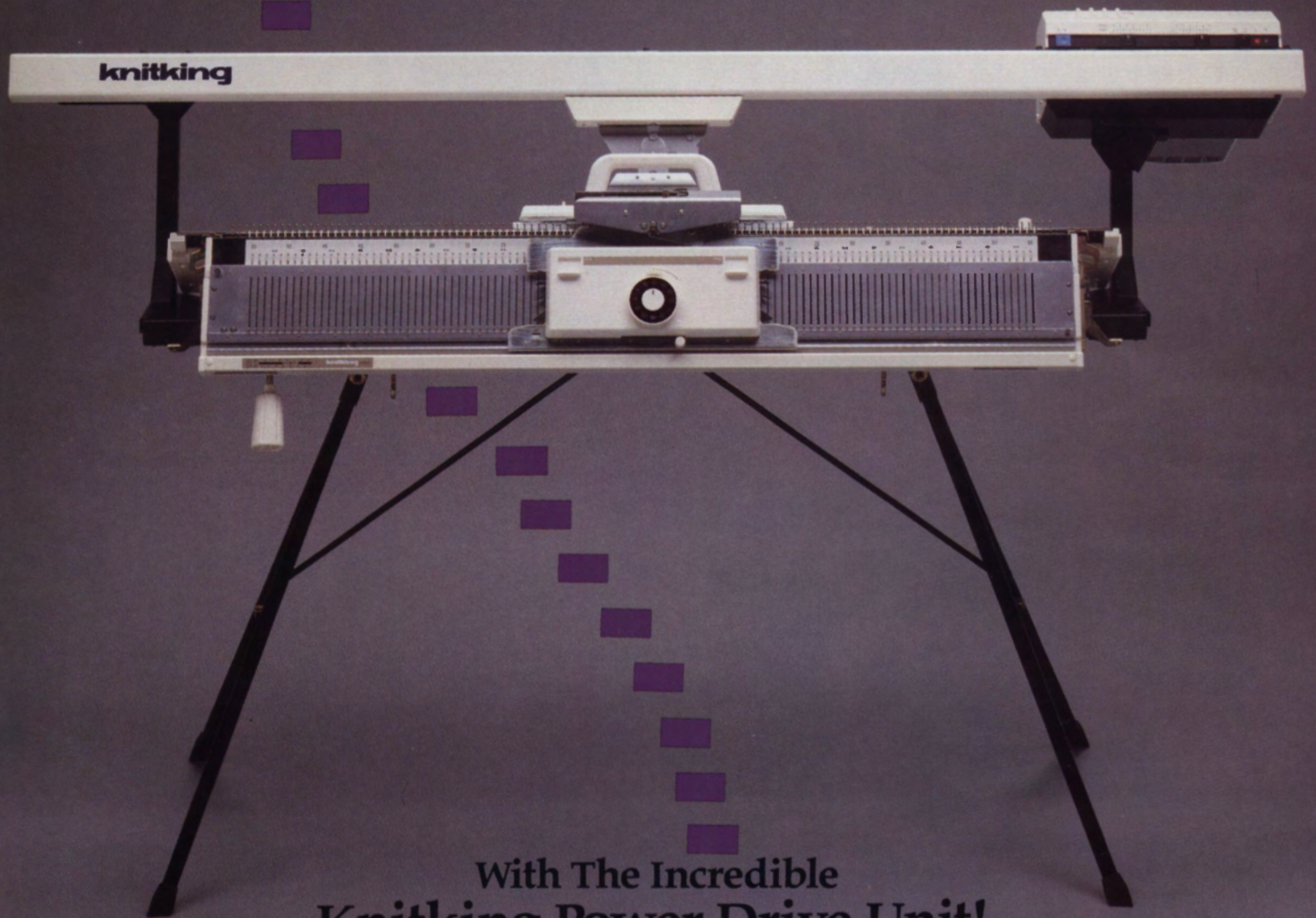

## With The Incredible Knitking Power Drive Unit!

It attaches to the carriage of your Knitking knitting machine and, with the push of a button or tap of the foot pedal, automatically moves the carriage back and forth across the knitting bed!

**knitking**

Where Savings And Value  
Are Always In Fashion

1128 Crenshaw Blvd., Los Angeles, CA 90019 213-938-2077

# The Unequaled Features of the KNITKING POWER DRIVE UNIT Will Help Make the Ease and Speed of Garment Creation More Incredible Than Ever!

Operates at two speeds to best accommodate your stitch type, and the weight and

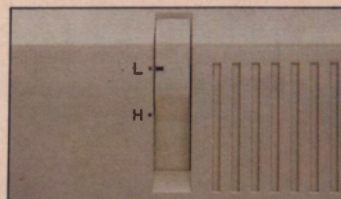

tension of your yarn.

Turn on the motor by the press of a button or the tap of an optional foot



pedal, for continuous or one-row-at-a-time knitting.

Easily control the distance left and right that the carriage



will travel.

## It turns itself off automatically

Set the row counter for the number of rows

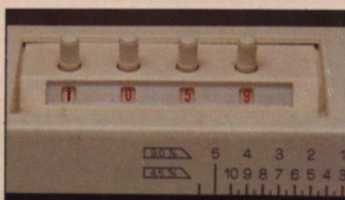

you want to knit and the PDU will shut off automatically when the preset row number is complete.

Yarn Tension Unit with special

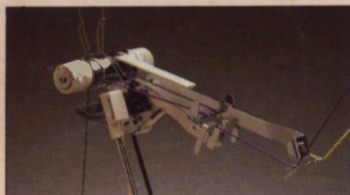

sensors shut off the Unit automatically if the yarn runs out, breaks, or if a knot is detected.

## It's complete and versatile

The Knitking Power Drive Unit comes complete with

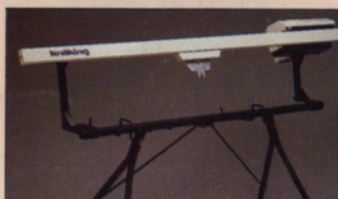

a sturdy, custom designed table-stand.

It can be used with both standard bed and bulky knitting machines



... with no additional parts or attachments!

# knitking

1128 Crenshaw Blvd., Los Angeles, CA 90019 213-938-2077