



**Go For  
The Best**

and knit any of our Spring into Summer garments. We have designed them all to keep you happily knitting for yourself and for all members of your family.



# 672 Perfect Put-Togethers

A special rib pattern make a Skirt that is topped with a lovely sleeveless shell. Cables are down the front panel and it has a soft Collar. Combine Skirt and Shell with a beautiful Jacket that has panels of cables repeated on the sideways knitted sleeves. Make it on any standard machine with ribber. Venetia is the yarn.

673

# Surprise

Wear this lovely figure flattering two piece Dress with its demure front and surprising deep plunging neckline at the back. It is easy to knit on any standard machine with ribber. Adorn it with a favorite necklace. Knit it with our new Starlite yarn.



# Table of Contents

KNITTING MAGAZINE - VOLUME 22 NO. 2

0000 GENERAL INSTRUCTIONS	12
671 WOMENS DRESS	13
672 LADIES 3 PC. ENSEMBLE	15
673 WOMENS 2 PC. TOP AND SKIRT	17
674 WOMENS PULLOVER	18
675 MENS PULLOVER	19
676 WOMENS 2 PC. DRESS	20
677 WOMENS TOP AND SKIRT	21
678 WOMENS DRESS	22
679 WOMENS PLATED TOP	23
680 WOMENS 2 PC. DRESS	25
681 WOMENS 3 PC. ENSEMBLE	26
682 WOMENS PULLOVER WITH LEAVES	29
683 GIRAFFE TOP	30
684 WOMENS DRESS	31
685 WOMENS 2 PC. DRESS	33
686 WOMENS JACKET	34
687 MENS CARDIGAN	35
688 WOMENS DRESS AND COAT	36
689 THREAD LACE DRESS	39
690 PANDA SWEATER DRESS	40
691 CHILDS CARDIGAN	41
0000 KNITTING NEWS	43

## Cover



# 671

## Unbelievably Beautiful

is a new up-to-the-minute Fair Isle Jacket that is knitted in sections on any electronic machine with Ribbing Attachment. Applied trim is Snakeskin. The bands are ribbed and the yarn is Venetia and Metallic. A jacket type zipper and buttons are needed.

# Editorial

We have told the story before but it is certainly one worthy of retelling, especially in this Olympic year.

Anabel Moriarty lived in Stowe, Vermont and she had a son, Marvin, who became such a good snow skier that he was chosen to represent the U.S.A. in the Olympics . . . In 1956 Anabel purchased a knitting machine from KNITTING and the first thing she wanted to knit was a ski hat for her son that would be snug and warm. She taught herself how to use the machine but her learning skills were not quite fast enough for Marvin who was in a hurry to get that hat. Anabel had not yet learned how to shape a curve to fit over the top of the head so she just decreased one stitch on each side every other row and finished off with a point at the top. She knitted with four-ply worsted at a tight tension . . . The hat was made of two flat pieces, approximately nine inches long at the sides and twelve inches at the point in the middle. She joined the pieces on a sewing machine. When worn the hat could be pulled down to cover the ears or rolled up a few inches and worn above the ears.

Marvin wore it for a practice run and it was an instant hit . . . Everybody on the Olympic ski team wanted one and Anabel was in business. Since that time the "Moriarty" has become the most copied hat in the world. In the 1970's it was practically the only ski hat sold throughout the world. Anabel had up to thirty knitters working for her full time and her company alone produced over two million hats, all on KNITTING machines.

If you were fortunate enough to see the opening ceremony of the 1980 Winter Olympics you would have seen practically every team wearing the celebrated Moriarty design hat. Tamara McKinney and many of her friends on the U.S. women's Olympic ski team wore hats with rabbit designs on them. These hats were also made on KNITTING machines by Ouisha McKinney, a KNITTING dealer in Lexington, Kentucky. She is Tamara's sister.

The Moriarty hat was the popular hat again in the 1984 and 1988 Winter Olympics. The company is under new ownership and still flourishing with an average of 25 knitters employed. Hat designs and other knitted products are more diversified but the original Moriarty hat is still the most popular on the slopes and Stowe, Vermont is referred to in the National press as the home of the Moriarty hat.

This unique hat, that was an accident of design, has now achieved what is perhaps the ultimate reward. It is featured as a special issue Olympic stamp by the U.S. Postal Service and is pictured worn on the head of a downhill skier.



The Moriarty story is one of many known to us, of KNITTING customers who become entrepreneurs. One day we will tell you about St. John knits, the company that has several factories, several hundred KNITTING machines, hundreds of operators and whose sales are approaching fifty million dollars annually.

674 &  
675

## Nautical and Nice

Pull up the anchor and sail away on a vacation adventure. Each of you can wear a bright and fun to knit Pullover. We knitted them both with our newest Bulkytime yarn, on the bulky Punch Card machine of course. All bands are 1 x 1 ribbing.





# 676 Beautifully Simple

A very easy to knit two piece Dress is in Stockinette stitch with plating technique. The Skirt is knitted sideways and has a soft flare at lower edge. Wide sleeve cuffs and waistband are K1, P1 ribbing. A novelty chain drapes from shoulder fringe to a pretty pin at waist. Knit it with Venetia, Glace and Mirage in Sizes 8 to 16.



677

## Glorious Color

---

on a Fair Isle Blouse teams up with a new short length full needle rib Skirt. We knitted the two piece Dress with our 'Special Sale' yarn for a bargain price to you. It was made on an Electronic machine, but a Punch Card machine can be used as well.

678

## Textured Beauty

Take it easy and set your Garter Carriage turtling along. You will love the results and will wear this smart Pullover everywhere. A great beginners design for the new owner of a Garter Carriage. Acrylite is the yarn.





679

# Applique

shows up on garments everywhere and our beautiful Pullover is accented with snakeskin applique leaves. You outline the 'V' insert and the full dolman sleeves. It's plated with Glace and Venetia in Stockinette stitch. The bands are ribbed.





## 680 **Bulky Mini**

For the young at heart . . . a lovely, easy to knit  
Skirt and Blouse. Large buttons simulate a  
double breasted Jacket. Knit it on any bulky  
machine with Ribber in no time at all, using our  
bulky Venetia.

# 681

## Striking Beauty

---

A Ribbing Attachment is needed for knitting this three-piece elegant ensemble with no floats on the back. The sleeveless Shell is Stockinette stitch and has a single motif. Note the single rose on the lower section of skirt. Knit it with fine Venetia and Lurex.





**682**

## **Pleasing Petals**

---

decorate the shoulders of a lovely Pullover that is knitted in two Tuck Stitch designs. A scattering of Pearls accentuate the Tuck stitches. The Petals are knitted separately then applied in place. The bands are ribbed.



# General Instructions

## THE PRINTED INSTRUCTIONS

Follow the printed instructions or use them in combination with the Charts. When there is any question in the instructions, you have the Charts to show you how the section will look.

Be sure to READ AHEAD so that you KNOW what to do for the size you are knitting. In the shapings, where the number of stitches are the same but the number of times different, you might find shapings like this...3 sts. 1 (2) [3]x - so that for the first size you will bind off 3 sts. 1x, 2nd size 3 sts. 2x, 3rd size 3 sts. 3x. Sometimes the ROWS will be different for each size-so you must watch out for different row numbers.

Shoulder and neck shapings for the back section of a garment usually are shaped at the same time-so ALWAYS WATCH for the words, AT THE SAME TIME.

## HOLDING STITCHES ON THE LEFT SIDE WHILE SHAPING THE RIGHT SIDE

There are different ways to hold stitches on one side while completing the other side. Usually, we tell you to bind off the center sts. for neck and put the left side into holding position while completing the right side. The easiest way, and really the best for beginners, is to take a piece of RAVEL CORD and hand knit the center neck stitches, pulling them back against the needle bed of machine to the "A" or out of work position. The stitches remain in the HOOKS of the needles so you are really only knitting them HALF WAY. With another color of Ravel Cord, knit the remaining sts. on the left side in the SAME WAY.

It is important to protect these held stitches in some way-so you can either hang a REVERSING BAR so that the EYES of the bar go BETWEEN the Gate Pegs on the machine and that the UPPER TIPS of bar only show above the needle bed, OR the simplest way is to use a piece of 1" masking tape and GENTLY place it beneath the knitting-right below the Gate Pegs. DO NOT press the tape, only enough pressure to hold it in place. This will prevent the Carriage (or Slide) from marking the held section.

It is VERY IMPORTANT that you mark the PATTERN ROW where you divide for the split for NECK (or SHOULDER) shaping. If you are using a PUNCH CARD, mark the card-if you are using an ELECTRONIC machine, mark the design window. Also take note of the Row number for the division. When you are ready to work the left section, bring the HELD stitches back to "B" (working) position by pulling each end of the Ravel Cord GENTLY and ripping it off. Be sure to align all needles straight in the "B" or knitting position.

Now you are ready to REFER TO YOUR OWN INSTRUCTION MANUAL for your machine to set the controls to begin knitting the left half. The neck stitches can be bound off after completing the right side, or you can leave them in hold until each side is finished. Bind off or remove them onto contrast waste yarn ready to be picked up for knitting a neckband or for other finishing.

## FULL FASHION DECREASING OR INCREASING

For stockinette stitch, use the Full Fashion method for decreasing or increasing (except for regular cap shaping on sleeves where you decrease the edge stitch). TO DECREASE: Hang the 3rd stitch onto the 2nd stitch, then move the end stitches in to fill the empty needle.

TO INCREASE: Move the 2nd end stitches 1 needle outward, then pick up the 3rd stitch from the row below and hang it onto empty needle.

## PATTERN SYMBOLS

( ) Symbol for 2nd size.

[ ] Symbol for 3rd size.

There are up to 3 sizes given for Patterns in KNITTING MAGAZINE. For example, the Charts and printed instructions will show the cast on as - 124, first size, (132), second size, [140] third size.

☐ Needles in holding position.

☒ Needles back into working position

☐ Needle not used-in out of work position

3x1 The number in the box is the number of Rows between shapings. The

☒ 3x1 above the box gives the sts., and the number of times to make the decreases (or increases). For example: 3x1 over the box with 4 means- At the given Row number, \*decrease 1 st., knit 4 rows\* and REPEAT from \* to \* 2 times more for a total of 3 times in all. All decreasing (or increasing) WITHOUT ROW NUMBER IN BOX must be made on EVERY 2ND ROW.

## THE SAMPLE SWATCH

Before you knit any garment, you must knit a sample swatch using the yarn you have chosen for your garment. If you do not get the correct Stitch and Row Gauge as given for a Pattern in KNITTING MAGAZINE, try different tensions. If you are using the specified yarn, you should be able to get the correct gauge using a smaller or larger tension. If you are using a different yarn, you may have to make several swatches, but the gauge is very important.

To make a sample swatch, Cast on 60 stitches with waste yarn and knit 6 rows. Mark the tension number for your sample swatch by making holes (you can do this with a Lace Carriage or by hand), 4 transfers for Tension 4, 6 transfers for Tension 6, etc. Knit 6 more rows.

Change to garment yarn and set Counter at 0. Knit 30 rows (in Stockinette stitch or Pattern stitch, according to the garment). With Contrast waste yarn, knit the 10th stitch FROM EACH SIDE by hand. Knit 30 rows. Change to waste yarn and knit 12 rows. Remove the sts. from the machine by pushing the Carriage (or Slide) across without yarn.

Pull and stretch the sample swatch both lengthwise and diagonally from corner to corner, then lengthwise again. Gently block the swatch (KNITTING PRESSING CLOTHS are great for this), or you can allow the sample to rest several hours or even over night so that the stitches can return to their basic form.

THE KNITTING STITCH/ROW GAUGE and STITCH/ROW CALCULATOR can be used to find the NUMBER OF STITCHES or ROWS TO 1". After knitting a sample swatch place the STITCH/ROW GAUGE horizontally with the START LINE on the INSIDE of LEFT stitch mark on sample. Keep it straight then read the number on the Gauge directly below the inside RIGHT mark on Gauge. This will give you the STITCH GAUGE TO 1". For instance, if the number is 8, then you have 8 stitches to 1". To find the ROWS TO 1", measure from the first row of garment yarn, VERTICALLY to the last row. Read the NUMBER from the LOWER EDGE of GAUGE, same as you did for stitches and if the number should be 14, you have 14 rows to 1".

12 Rows		12 Rows
60 Rows	10 • 40 STS • 10 ↑ Mark                      ↑ Mark	30 Rows 30 Rows
12 Rows	○○○○ tension holes contrast yarn	6 Rows 6 Rows
60 STS		

THE STITCH/ROW CALCULATOR will now give you the number of sts. or rows needed for a specific measurement. Line the ARROW to the number 8 (8 sts. to 1"). Should you need 20 inches of stitches, find the number 20 below and right above the 20 the Calculator shows 160 sts. It works the same way for rows using the Row Gauge.

## FINISHING

Gently block all sections-For PULLOVERS, JACKETS, and DRESSES: Join the front to back at shoulders and sides. Sew sleeves together and set in. Hem lower edge and sleeve edges if needed. For a double neckband or armhole band, sew 1 edge to inside and 1 to the outside of neck or armhole. For a single ribbed band, sew 1 edge to the outside of neck or armhole edge. For a cardigan or jacket with buttonholes, finish buttonholes and sew on buttons.

PANTS: Join front to back at sides. Sew inside leg seams, then join to center front and back. Make hem at waistline and inset elastic. Hem lower edge of pant legs.

## ABBREVIATIONS

BO	Bind Off	L.C.	Lace Carriage
Carr.	Carriage	MB	Main Bed
CO	Cast on	Ndls.	Needles
Col.	Color	Pat.	Pattern
Dec.	Decrease	P	Purl
EON	Every Other Needle	RB	Ribber Bed
FNR	Full Needle Rib	R	Row
G.C.	Garter Carriage	St.	Stitch
G.S.	Garter Stitch	St. st.	Stockinette Stitch
HP	Holding Position	Strnd	Strand
Inc.	Increase	T	Tension
I.C.	Intarsia Carriage	W.Y.	Waste Yarn
K	Knit	WP	Working Position

# 671



## LADIES JACKET

**SIZES:** S/M (L)  
**YARN:** Venetia and Metallic  
**AMOUNT:** Same for both  
 Col. 1 Beige Ven. 1 lb.  
 Col. 2 Dk. Br. Ven. 1 lb.  
 Col. 3 Cinnamon V. 1 lb.  
 Col. 4 Metallic 2 cones  
**NOTE:** Color 4 = 2 strands together throughout  
**KIT PRICES:** \$130.00  
 Snakeskin Kit: Add \$40.00 to kit price. Can be purchased separately.  
**TENSION:** Eng. Rib 1/1 I, at 'P'. FNR 4/4 I, K1/P1 rib 1/1 II at 'H'.  
**GAUGE:** FNR 16.5 sts and 33.5 rows = 2" (5 cm.)  
 Eng. Rib, 20 sts. 32 rows = 2"  
**NOTIONS:** Four strips of Snakeskin 3/4" wide and 50" long. One strip of Snakeskin 3/4" wide and 22" long. Four buttons and 1 Jacket-type zipper (21"-22" long).

Make on any Electronic machine with ribber.  
 Fair Isle design is knit with the Color Changer so there are no floats.

**CENTER BACK PANEL:** Make 1. FAIR ISLE DESIGN WITH NO FLOATS TECHNIQUE  
 FNR: With Col. 1 cast on 60 sts. After selvedge, knit 3 rows. Set Fair Isle pattern, add color 4 (remember 2 strands together). Continue in Fair Isle. After R414 (430) transfer rib sts. to MB. Mark st. 8 (7) on each side and BO.

**SIDE PANELS:** English rib. Make 4: (2 for the back and 2 for the front). Use 2 strands of Col. 2 together throughout.  
 K1/P1 rib: With Col. 2 cast on 51 (55) sts. After selvedge, set carriages for Eng. Rib and knit to R394 (410). Transfer rib sts. to MB and BO.

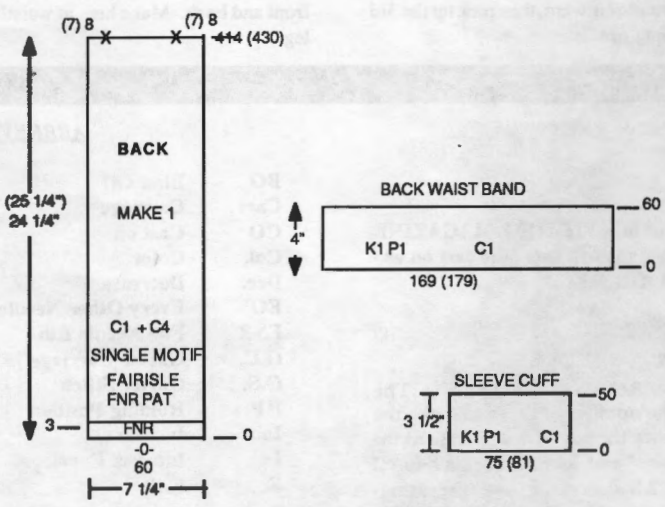
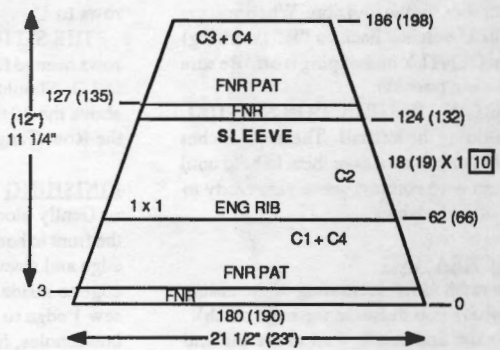
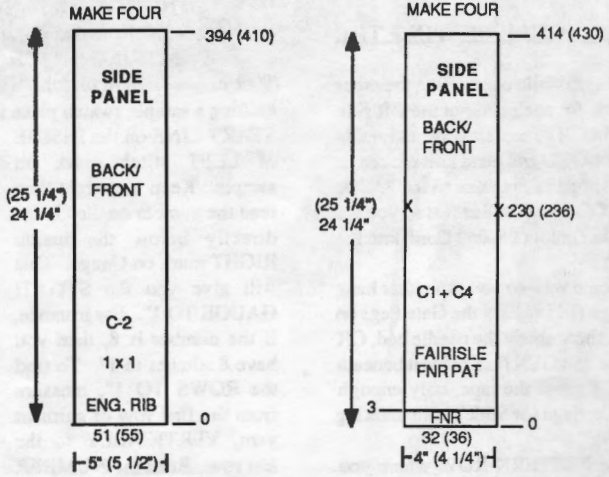
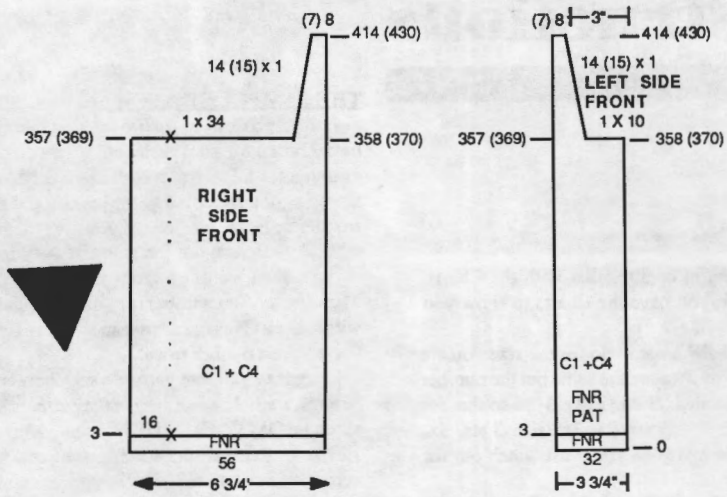

**SIDE PANELS:** FAIR ISLE design with no floats. Make 4 FNR: With Col.3 cast on 32 (36) sts. After selvedge, set pattern and with Col. 3 and Col. 4 knit to R230 (236). On each side mark with W.Y. for sleeve opening. After R 414 (430) transfer rib sts. to MB and BO.

**FRONT: LEFT SIDE**  
 Make 1. FAIR ISLE design with no floats.  
 FNR: With Col. 1 cast on 32 sts. After selvedge, set pattern and with Col. 1 and Col. 4 knit to R357 (369). On the right side BO 10 sts., then 1 st. EOR 14 (15) x. After R414 (430) transfer rib sts. to MB and BO.

**FRONT: RIGHT SIDE**  
 Make 1. FAIR ISLE design with no floats.  
 FNR: With Col. 1 cast on 56 sts. Mark with W.Y. the 16th ndl. from the left edge for front fold. After selvedge set Fair Isle pattern and with Col. 1 and Col. 4 knit to R357 (369). On left side BO 34 sts., then 1 st. EOR 14 (15) x. After R414 (430) transfer rib sts. to MB and BO.

**SLEEVES:** FAIR ISLE design with no floats.  
 FNR: With Col. 1 cast on 180 (190) sts. After selvedge set pattern and continue with Col. 1 and Col. 4 in Fair Isle. On each side BO 1 st. every 10 rows 18 (19) x. After R62 (66) change to Eng. Rib. (Transfer every other needle to obtain K1/P1 needle arrangement. With Col. 2 at T1/1, I, continue in Eng. Rib. to R124 (132). Remember to continue decreases on both sides. Cancel Eng. Rib and place all ndls. into WP for FNR. Change to Col. 3 and knit 3 rows. Set Fair Isle pattern and with Col. 3 & Col. 4 continue in pattern. After R 186 (198) transfer rib sts. to MB, knit 1 row, and remove on W.Y.

**SLEEVE CUFFS:** K1/P1 rib: With Col. 1 Cast on 75 (81) Sts. After selvedge, at T 1/1 II knit 50 rows. Transfer rib sts. to MB and with the wrong side facing hang open sts. of sleeve onto these ndls. decreasing evenly across, and BO.

**BACK WAIST BAND:** Make 1.  
 Join 1 Eng. Rib panel to EACH SIDE of center. Then, 1 Fair Isle Panel on each side of Eng. Rib. (See Finishing).

**K1/P1 rib:** With Col. 1 cast on 169 (179) sts. After selvedge knit 60 rows. Transfer rib sts. to MB and with wrong side facing, hang Back onto these ndls.. BO.

**LEFT FRONT WAIST BAND:** Make 1. Join front panels together. (See Finishing)

**K1/P1 rib:** With Col. 1 cast on 95 (99) sts. After selvedge, knit 60 rows. Transfer rib sts to MB and with wrong side facing, hang Left Side Front onto these ndls. and BO.

**RIGHT FRONT WAIST BAND:** Make 1. **K1/P1 rib:** With Col. 1 cast on 107 (113) sts. After selvedge knit 12 rows. On right side make an 8 stitch buttonhole, starting on the 8th stitch from the right. Knit to row 48 and make 2nd button hole. After Row 60, transfer rib sts. to MB and with wrong side facing hang Right Front onto these ndls. (Please remember to allow for fold to cover zipper) and BO.

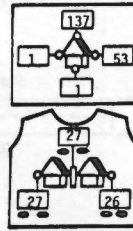
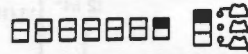
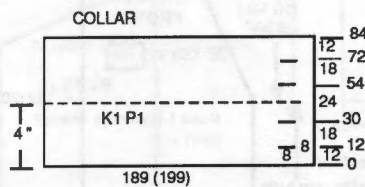
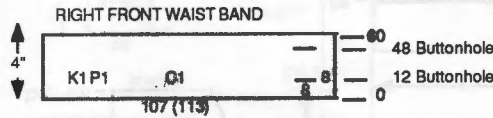
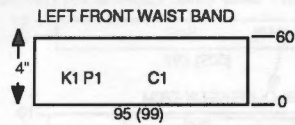

YEL. NDL. NOS. GRN. NDL. NOS.

**FINISHING:** Panels must be joined before knitting the waistbands. Carefully pin panels with **RIGHT SIDES TOGETHER AND BASTE** with sewing thread, making sure the lengths are correct and even (see measurements on Charts). Fold right front facing to the inside on the marked 16th stitch. Sew (or you can slip stitch crochet) the sections together one stitch in from edge. Weave or sew Collar to opening. Cut strips of Snakeskin about one inch longer than needed. Pin them with fine silk pins. Pin them in place to cover seams. Set your sewing machine for a zig-zag stitch and thread machine with matching thread. **PLACE PAPER UNDER THE KNITTING ON THE WRONG SIDE** and slowly stitch snakeskin in place on the right side on each edge. When completed, tear away the paper. Baste, then sew one edge of zipper to the left side of Jacket with the knitting edge 1/4" away from zipper tape. Sew the other edge of zipper to the **RIGHT** side of Jacket on the **INSIDE EDGE** so that fold-over covers zipper. Finish buttonholes and sew on buttons.

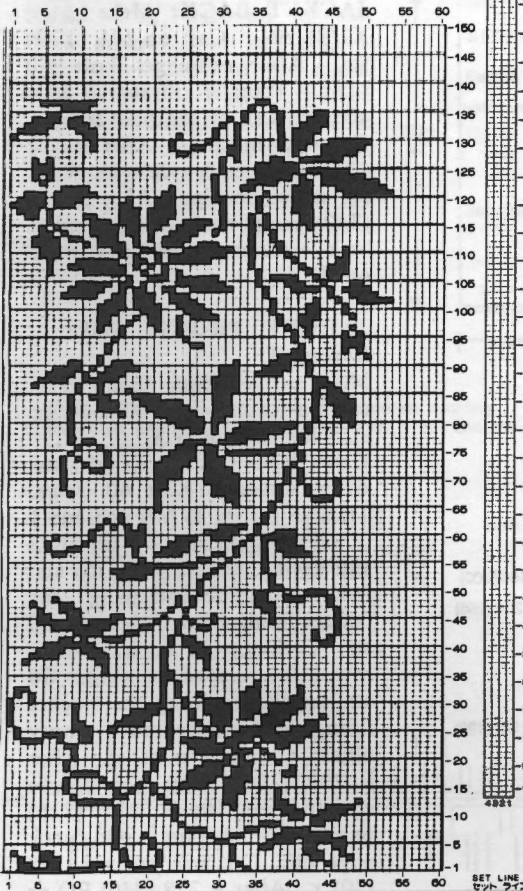

SEND \$1.00 PLUS SASE FOR ENLARGED COPY

# knitking

SEMINAR & OPEN HOUSE  
SEPTEMBER 13 - 17, 1988



Join us! Our open house runs from September 13 through 17 and will be held at KNITKING, 1128 Crenshaw Blvd, Los Angeles, CA 90019.

Come and meet our experts along with many acknowledged guest authorities. You'll get to see great new products too!

**Enjoy!** You'll love our daily Fashion show and contest! Daily winners will receive prizes and are eligible for the finals and a **GRAND PRIZE** at the close of the seminar.

*Among the outstanding teachers at the Seminar will be Yukiko Mitsumata, Mary Louise Norman, Jan Wold and Jan Mills, and many many more.*

**Win!** All types of garments are eligible, so start knitting now! (Sorry, knitting machine dealers and employees of KNITKING are not eligible).

**It's Free!** Just bring yourself and some friends and join us for prizes, events, and free coffee and doughnuts.

Our regular seminar visitors will tell you ours is the best, so remember to come and meet us here at KNITKING.

**Please note the revised date: September 13 through 17.**



**672**  
**Perfect**  
**Put-Togethers**

## LADIES 3 PC. ENSEMBLE

**YARN:** Venetia  
**SIZES:** 8/10 (12/14)  
**AMOUNT:** 50 oz. 52 oz.  
**KIT PRICE:** \$72.00 \$75.00  
**TENSION:** St. st. T 5, Skirt 4/4 I. K1/P1 rib. 1/1 II. FNR 1/1 I.  
**GAUGE:** St. st. 16 sts. 24 rows = 2" (5 Cm).  
 Skirt 19.5 sts. 23 rows = 2" (5 Cm).  
**Notions:** 5 buttons.

Make on any Standard or Electronic machine with Ribber attachment.

**BLOUSE BACK:** Make 1.  
 K1/P1 rib: Cast on 157 (165) sts. After regular selvedge knit 50 rows. Transfer rib sts. to MB. Add 1 st. on the right and continue in St. st. After R172 (180) mark each side with W.Y. for sleeve opening. After R 288 (300) mark with W.Y. for neck opening and BO or remove on W.Y.

**BLOUSE FRONT:** Make 1.  
 K1/P1 rib: Cast on same as Back and knit 50 rows. Transfer rib sts. to MB. Knit 2 rows st. st. On the right side, leave 57 (61) sts. in WP. Remove remaining sts. on the left on W.Y. and complete the right side first. Continue in st. st. After R172 (180) mark the right side with W.Y. for sleeve opening. After R 256 (266) on the left (neck edge) dec. 1 st. EOR 6 (8) x. After R 288 (300) BO or remove the remaining sts. on W.Y.  
 On the left rehang 57 (61) sts. with Row Counter at 52 and complete to match the right panel but reverse neck shaping. Side panels are completed, now complete the center panel. Rehang the center 44 sts. Add 1 st. on each side for seaming.

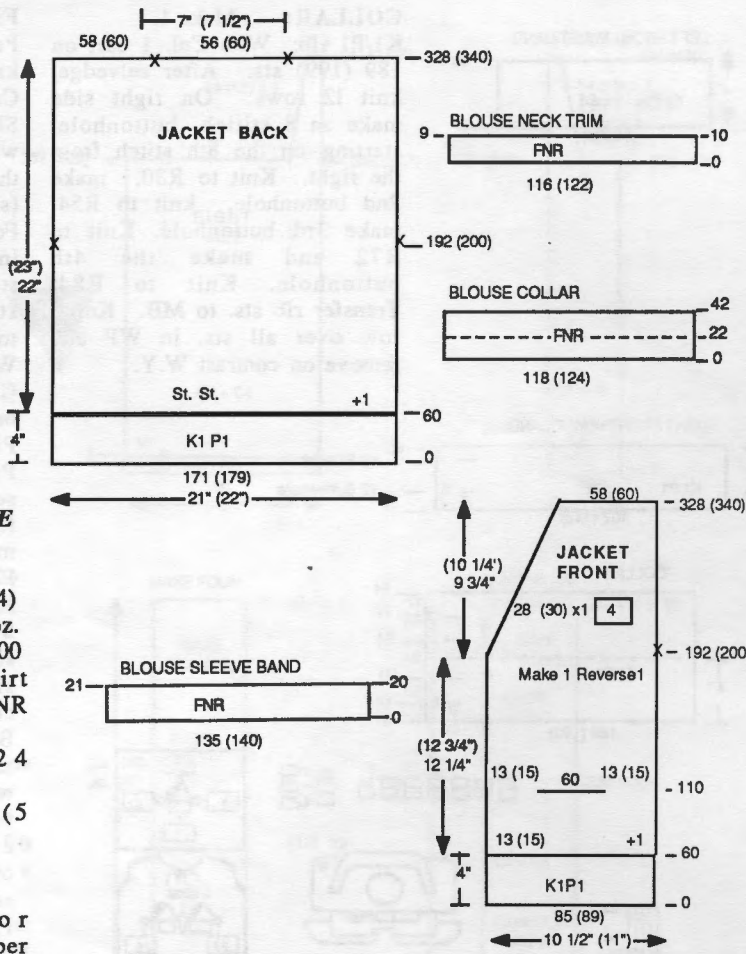

Bring the ribber into WP. Set lever to H (half pitch), and transfer ndls. to correspond with chart. At T 3/3 I make cables every 14 rows. After R 256 (266) BO.

**BLOUSE NECK TRIM:**  
 Make 1.  
 FNR: Cast on 116 (122) sts. After selvedge knit 9 rows. Transfer rib sts. to MB and knit 1 row across. Remove on W.Y.

**BLOUSE COLLAR:** Make 1  
 FNR: Cast on 118 (124) sts. After selvedge, at T 2/2 I knit 22 rows. Change to T 1/1 I and knit to R 42. Transfer rib sts. to MB and knit 1 row across. Remove on W.Y.

**BLOUSE SLEEVE BAND:**  
 Make 2.  
 FNR: Cast on 135 (140) sts. After selvedge, knit 20 rows. Transfer rib sts. to MB and knit 1 row across and BO.

**BLOUSE FINISHING:**  
 Join shoulders. Join center panel to side panels. Sew or weave neck band and collar to neck opening. Join sleeve bands to sleeve opening.

**JACKET BACK:** Make 1.  
 K1/P1 rib: Cast on 171 (179) sts. After selvedge knit 60 rows. Transfer rib sts. to MB and add 1 st. on the right side. Continue in st. st. After R 192 (200) mark each side with W.Y. for sleeve opening. After R 328 (340) mark neck opening with W.Y. markers and BO or remove on W.Y.

**JACKET FRONT:** Make 1, Reverse 1.  
 Make pocket lining first. W.Y. cast on 60 sts. Knit 50 rows st. st. Remove on W.Y.  
 K1/P1 Rib: Cast on 85 (89) sts. After selvedge Knit 60 rows. Transfer rib sts. to MB and add 1 st. on the right side. With right side facing, count in 13 (15) sts. from each side and hang the pocket lining onto the center 60 sts. Continue in st. st. After row 110, remove the center 60 sts. on W.Y. Hang the pocket lining onto these now empty ndls. Continue in st. st. After R 192 (200) mark for sleeve opening. After R 210 (216) begin neck shaping. On neck edge dec. 1 st. every 4 rows 28 (30) x. After R 328 (340) BO or remove remaining sts. on W.Y.



**JACKET FRONT/BACK BANDS:** Make 2 — 1 with buttonholes.

**FNR:** Cast on 192 (200) sts. After selvedge knit 9 rows. (if this is the band with the buttonholes, follow chart for buttonhole placement.) Knit to R 18. Transfer rib sts. to MB and knit 1 row across. Remove on W.Y.

**JACKET FRONT/BACK BAND** Make 1 with buttons and 1 without

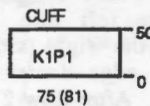
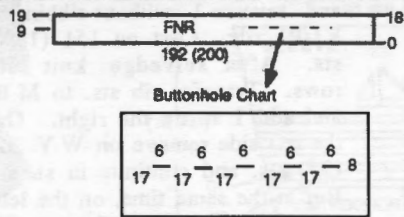

**POCKET TRIM:** Make 2.

**K1/P1 rib:** Cast on 60 Sts. After selvedge knit 18 rows. Transfer rib sts. to MB and knit 1 row across. Remove on W.Y.

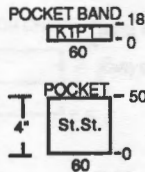

**SLEEVES:** Section 1, make 2. W.Y. cast on 66 (69) sts. After several rows end with 1 row ravel cord to the right. Change to garment yarn and knit 2 rows. Bring all ndls. to HP and set carriage for short rows. On same side as carr. push back into WP 3 sts. 22 (23) x. After Row 134 (140) mark each side with W.Y. for sleeve center.

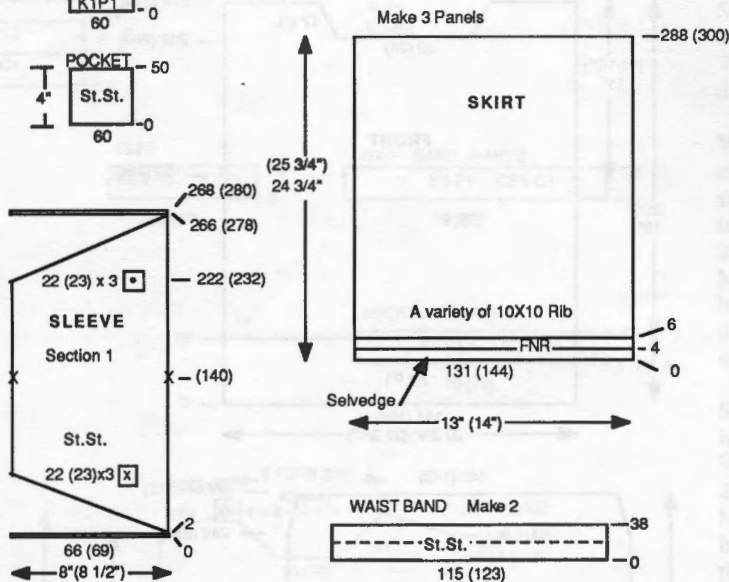

After R 222 (232) on side opposite carr. bring into HP 3 sts EOR 22 (23) x. After R 266 (278) knit 2 rows over all sts. and remove on W.Y.

**SLEEVES:** Section 2, make 2. **FNR:** W.Y. cast on 46 sts. After several rows end with 1 row Ravel Cord to the right. See Cable Chart and arrange ndls. accordingly. Make cable every 14 rows and knit to R 136 (142). Mark each side with W. Y. for center. After R 272 (284) remove sts. on contrast W.Y.

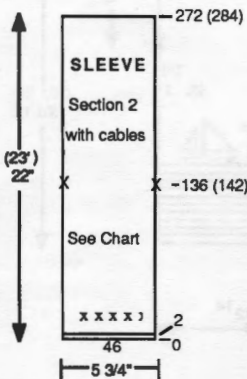

**SKIRT CHART**

After 4 rows of selvedge + 2 rows of FNR transfer sts. according to the chart. Begin at left with 6 needles on ribber in W.P. and end with 4 needles on right in W.P.

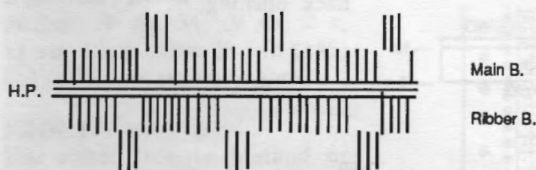

**CABLE CHART NEEDLE POSITION**

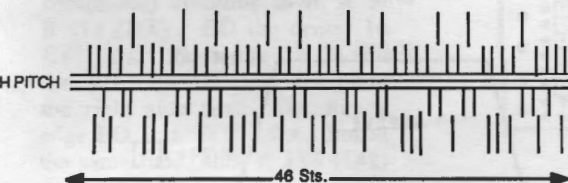

**SLEEVE CUFFS:**

**K1/P1 rib:** Cast on 75 (81) sts. After selvedge knit 50 rows. With wrong side facing hang sleeve edge onto these ndls. and BO.

**JACKET FINISHING:**

Join Sleeve section 1 to Sleeve section 2 using W.Y. markers as a guide. Close both shoulders. Join Bands to neck section. Join pocket trim to pocket edge.

**SKIRT:** Make 3 panels. Variation of 10 x 10 rib.

**FNR:** Cast on 131 (144) sts. After selvedge knit 2 rows. See chart and transfer sts. accordingly. At T 4/4 I knit to R 288 (300). Transfer rib sts. to MB and BO. With crochet hook single crochet 1 row around the top closing the pleats on top edge. Repeat for each section.

**SKIRT WAIST BAND:**

Make 2. Join the 3 skirt panels together. Bring 115 (123) ndls. to WP. With wrong side facing hang 1/2 skirt top onto these ndls. Knit 38 rows. Pick up first row to form hem and BO. Repeat for 2nd half of skirt.

**SKIRT FINISHING:**

Insert elastic in casing. Close band.

**THE GARTER CARRIAGE KNITS RIBBING AUTOMATICALLY AND MUCH, MUCH MORE!!**

The KnitKing Garter Carriage makes knitting Ribbing a breeze. With the press of a button, the Garter Carriage moves across your knitting machine on its own power! You can leave the room and your ribbing will be finished when you return!

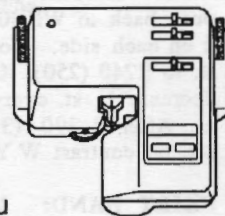

But ribbing is only the beginning of the story: The Garter Carriage automatically casts on, binds off and knits a multitude of fancy Garter Stitch patterns—beautiful textured three-dimensional designs impossible to knit any other way.

You merely select your desired pattern on your knitting machine (using the COMPUKNIT III keyboard, the COMPUKNIT II mylar sheets, or the KH 860 - KK 93 punch cards), set the number of rows needed, switch your Garter Carriage on, and leave to do other things. It will switch itself off when a garment section is completed or if the yarn runs out or breaks.

Order your Garter Carriage now from your local KnitKing dealer, or if you do not have one in your area, order direct from KNITKING, 1128 Crenshaw Blvd., Los Angeles, CA 90019. Phone: 213-938-2077.



## WOMENS 2 PC. TOP AND SKIRT

**YARN:** Starlite  
**SIZES:** 10/12 (14)  
**AMOUNT:** 25 oz. 27 oz.  
**KIT PRICE:** \$23.00 \$25.00  
**TENSION:** St. st. T 6, FNR 1.1/1.1 I, K1/P1 T 1.1/1.1 II.  
**GAUGE:** St. st. 14.5 sts. 22 rows = 2"

Make on any Standard or Electronic machine with Ribber attachment.

**SKIRT:** Front/Back the same  
**FNR:** With garment yarn C O 150 (158) sts. After selvedge knit 12 rows. Transfer rib sts. to MB and knit 2 rows st. st., then begin short rows. On side opposite carr. bring to HP 40 Ndl. Knit 1 row. On side opposite carr. bring 40 ndls. to HP. Knit 1 row. Be sure to wrap inside needle to prevent holes. On side opposite carr. push back to WP 10 sts. EOR 4 x on each side. Continue in st. st. to R240 (250). On each side decrease 1 st. every 10 rows 5 x. After R 290 (300) remove sts. on contrast W.Y.

**SKIRT BAND:** Make 2.  
 W.Y. cast on 122 (130) sts. After Ravel Cord Row, change to garment yarn and Knit 32 R. Pick up 1st Row to form hem. With wrong side facing hang open sts. of skirt onto these ndls. decreasing evenly across. B.O.

**FRONT:** Make 1.  
 K1/P1 rib: Cast on 151 (159) sts. After selvedge, knit 60 rows. Transfer rib sts. to MB. Add 1 st. on the right. Continue in st. st. to R150 (156). Mark each side with W.Y. for sleeve opening. After R232 (240) shape neck. BO the center 20

(24) sts. Place the remaining sts. on the left into HP and complete the right side first. \*On neck edge decrease 1 st. EOR 17 x. After Row 274 (284) remove remaining sts. on contrast W.Y. Bring sts. on the left back into WP. Turn counter back to 232 (240) and complete the right side. Follow Instructions from \*.

**BACK:** Make 1 with ribbing and reverse 1 without ribbing. K1/P1 rib: Cast on 151 (159) sts. After selvedge knit 60 rows. Transfer rib sts. to MB and add 1 st. on the right. On the left side remove on W.Y. 32 (35) sts. and continue in st. st. But at the same time, on the left side BO 1 st. every 3 rows 71

(74) x. After row 150 (156) mark side with W.Y. for sleeve opening. After R274 (284) remove remaining sts. on W.Y. Reverse Back section: Bring 120 (125) ndls. to WP. Starting at left side rehang the 32 (35) sts. held on W.Y. With bodice folded to inside rehang the remaining 88 (90) sts. from last row of ribbing. Continue as for first section but reversing all shaping.

**SLEEVES:**  
 Close shoulders first. Bring 162 (170) ndls. to WP. With wrong side facing and using W.Y. markers as a guide, hang sleeve opening onto these ndls. On each side Dec. 1 st. EOR 9 (10) x. Then Dec. 1 St. every 5th row 22 (24) x. After R134 (140) remove remaining sts. on W.Y.

**SLEEVE CUFFS:**  
 K1/P1 rib: Cast on 65 (69) sts. After selvedge knit 60 rows. Transfer rib sts. to MB. With wrong side facing hang open sts. of sleeve onto these ndls. decreasing evenly across. BO.

**BACK NECK BANDS:**  
 Make 2.  
**FNR:** Cast on 144 (150) sts. After selvedge knit 12 rows. Transfer rib sts. to MB. and knit 1 row over all ndls, in WP. and remove on W.Y.

**FRONT NECK BAND:**  
 Make 1.  
**FNR:** Cast on 66 (70) sts. After selvedge knit 12 rows. Transfer rib sts. to MB. Knit 1 row over all ndls. in WP. Remove on W.Y.

**FINISHING:**  
 See General Instructions. Weave or sew neck bands to neck opening.

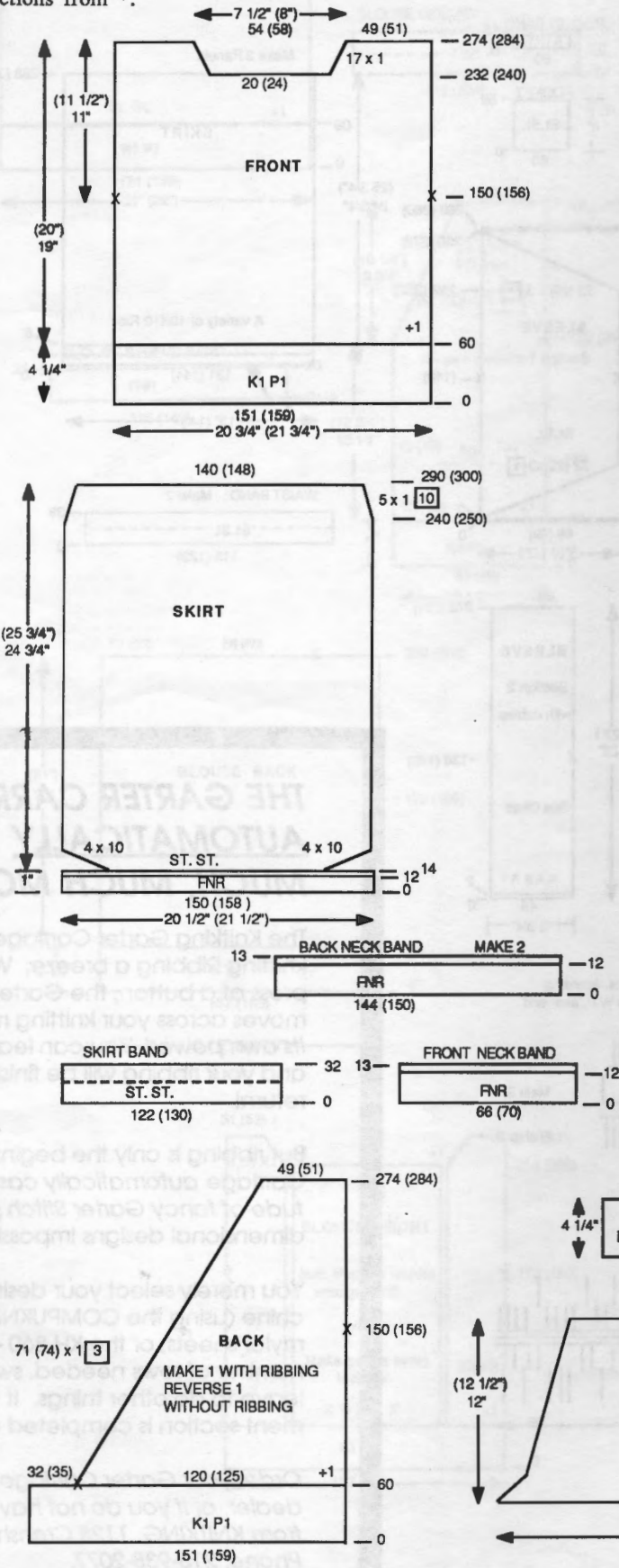

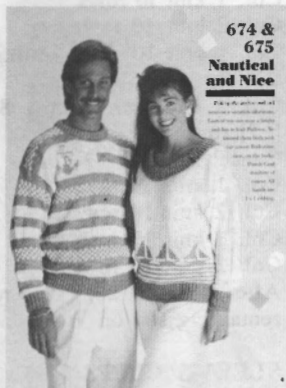

674 & 675  
Nautical and Nice

## WOMENS PULLOVER

**YARN :** Bulkytime  
**SIZES :** 8/10 (12/14)  
**AMOUNT :**  
 Col. 1- White 20 oz. 22 oz.  
 Col. 2- Blue 8 oz. 10 oz.  
 Col. 3- Venetia 1 Oz. (used in ribbing only.)  
**KIT PRICE :** \$24.00 \$27.00  
**TENSION :** St. st. T 2.1, Rib.  
 Neckband T 1/1 I, Rib Bands.  
 1.2/1.2 II.  
**GAUGE :** 10 sts. 13 rows = 2" (5 Cm)

Make on the Bulky Machine. Boat design can be done, either with Intarsia method or Fair Isle Punch card. Bands are K1/P1 rib (we used Intarsia method).

**BACK :**  
 W.Y. cast on 96 (102) sts. After several rows end with 1 row ravel cord to the right. \* Change to Col. 1 and knit 2 rows. Change to Col. 2. Knit 2 rows. \* Repeat from \* to \* 5 x. After R 20 continue with Col. 1 only. After R 76 (78) mark each side with W.Y. for sleeve. After R 136 (142) shape shoulders. BO or use short row method, 9 sts. 3x, (9 sts. 2 x, 11 sts. 1 x.) After R 142 (148) BO or remove on waste yarn.

**FRONT :**  
 Use either Intarsia Method or Fair Isle Method. Same as back to R 20. After R 20 set boat pattern. After R 42 ( Boat completed) continue in st. st. to R 114 (118). BO the center 14 (16) sts. Place the Ndl. on the left into HP and complete the right side first. On neck edge BO 1 st. EOR 14 x. But at the same time, after R 136 (142) shape shoulder, same as back. Bring Ndl. on the left back into WP. Turn counter back to 114 (118) and complete to match the right side.

### STRIPE COLOR CHART

C2	2	R
C1	2	R
	0	

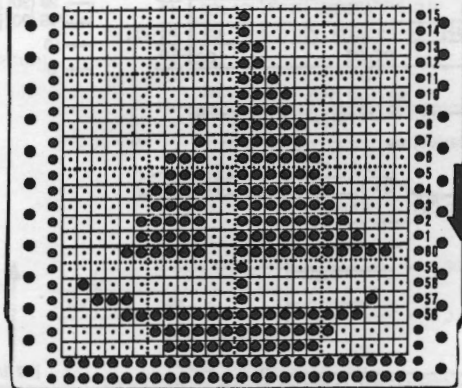
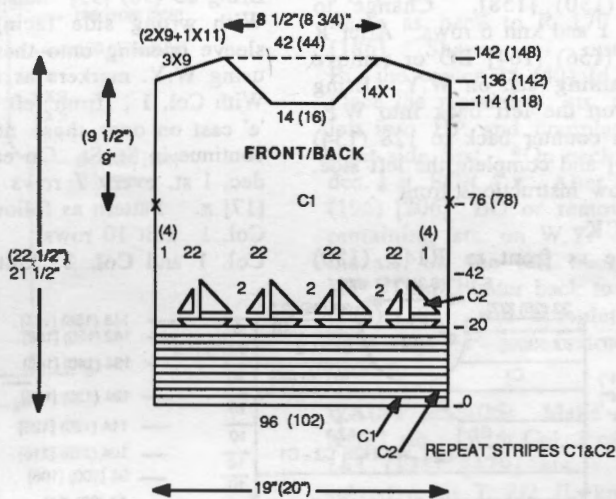
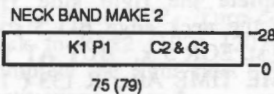
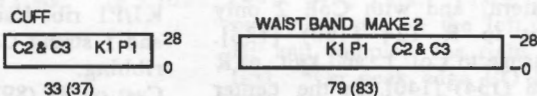
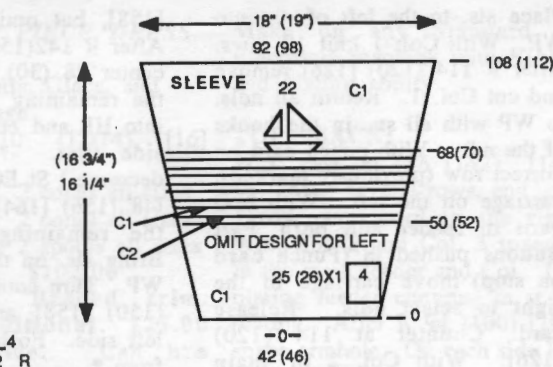

**SLEEVES :**  
 W.Y. cast on 42 (46) sts. After ravel cord row change to Col. 1 and continue in st. st. On each side inc. 1 st. every 4 rows 25 x. (1 st. every 4 rows 26 x). At the same time, after R 50 (52) Change to Col. 2 and knit 2 rows. Change to Col 1 and knit 2 rows. Repeat alternating these 2 colors through R 68 (70). Set Boat Pattern. ( 1 Single Motif in center). After R 108 (112) BO or remove on W.Y. Second Sleeve has no design.

**WAISTBANDS :**  
 make 2 K1/P1 rib : With 1 strand Col. 2 and 1 strand Col. 3 together, cast on 79 (83) Knit 28 rows. Transfer rib sts. to MB and with wrong side facing hang open sts. of Front/Back onto these ndls. decreasing evenly across. BO .

**SLEEVE CUFFS:**  
 K1/P1 rib: Cast on same as Waist Bands, 33 (37) sts. Knit 28 rows. Transfer rib sts. to MB. With wrong side facing hang open sts. of sleeve onto these ndls. decreasing evenly across. BO

**NECKBAND :**  
 make 2 K1/P1 rib : With 1 strd. Col. 2 and 1 strd. Col. 3 together, cast on 75 (79) sts. Knit 28 rows. Transfer rib sts. to MB and remove on W.Y.

**FINISHING :**  
 See General Instructions. Join the 2 pcs. for neckband and weave to neck opening. Crochet loops for buttons.

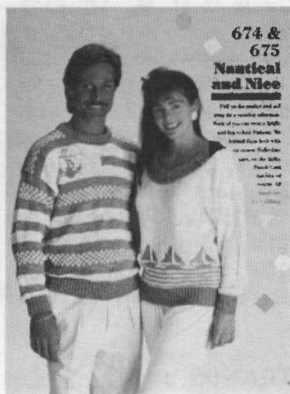

## MAN'S PULLOVER

**YARN:** Bulkytime & small amount Venetia for Ribbing

**SIZES:** Sm (Med) [Lge]

**AMOUNT:**

Col. 1: Blue 14 oz 15 oz 16 oz

Col. 2: White 11oz 12 oz 13 oz

Col. 3: Venetia: 2 oz. all sizes

**KIT PRICE:**

\$23.00 \$24.50 \$26.00

**TENSION:** St. st. T 2.1 , Rib

1.2/1.2 II

**GAUGE:** 10 sts. 13 rows = 2" (5cm)

Make on the Bulky Punch card machine with Ribber.

**FRONT:**

W.Y. cast on 98 (104) [110] sts. After several rows, end with 1 row ravel cord to the right. Change to Col. 2 and knit 10 rows st. st. Change to Col. 1 and knit 8 (10) [12] rows, setting Fair Isle pattern on the last row. With Col.1 and Col. 2 knit 10 rows in Fair Isle. Cancel Fair Isle and with Col. 1 knit 8 (10) [12] row. Change to Col. 2 and knit 10 rows. Change to Col. 1 and knit 10 rows. Change to Col. 2 and knit 10 rows. Change to Col. 1 and knit 10 rows. Change to Col. 2 and knit 10 rows setting Fair Isle pattern on the last row. With Col. 1 and 2 knit 10 rows Fair Isle. After R94 (98) [102] mark each side with W.Y. for sleeve opening. Change to Col. 1 and knit 10 rows. Change to Col. 2 and knit 1 row to the left. Set pattern for anchor (single motif). You may use either the Motif Knitting Cams (L) (R) or push back the needles that appear outside the single motif. Knit 1 row to the right to select ndls. and continue in single motif. After R 104 (110) [116], place the sts. to the left of -0- into HP and continue anchor design on the right. After R 114 (120) [126] MARK ROW NO. ON PUNCH CARD. Bring ndls. on the right to HP. Remove Col. 2 from feeder.

Place sts. to the left of -0- into WP. With Col. 1 knit 10 rows. After R 114 (120) [126] remove and cut Col. 1. Return all ndls. to WP with all sts. in the hooks of the ndls. With punch card on correct row (previously marked), carriage on the left. With NO yarn in feeder and both Part Buttons pushed in (Punch card on stop) move carriage to the right to select ndls. Release card. Counter at 114 (120) [126]. With Col. 2 in main feeder and Col. 1 in feeder B continue in Anchor design. After R 122 (128) [134] cancel pattern. and with Col. 2 only knit to R 124 (130) [136]. Change to Col. 1 and knit to R 128 (134) [140]. In the center BO 16 (18) [20] sts. Place the sts. on the left into HP and complete the right side first. \*On the neck edge BO 3 sts. 1 x, 1 st. EOR 5 x. BUT AT THE SAME TIME After R 133 ( 139) [145] set Fair isle pattern and with Col. 1 and Col. 2 knit to R 142 (150) [158]. Change to Col. 1 and knit 6 rows. After R 148 (156) [164] BO or remove remaining sts. on W.Y. Bring sts. on the left back into WP. Turn counter back to 128 (134) [140] and complete the left side. Follow instructions from \*.

**BACK:**

Same as front to R142 (150)

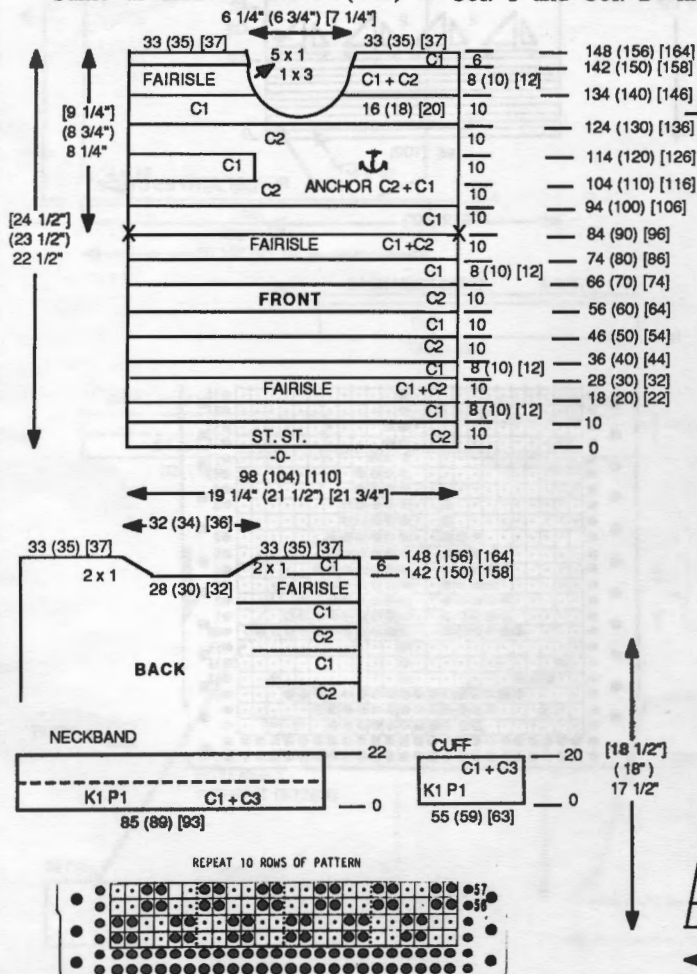

[158], but omit Single Motif. After R 142(150) [158] BO the center 28 (30) [32] sts. Place the remaining sts. on the left into HP and complete the right side first. \*On Neck edge decrease 1 St EOR 2 x. After R 148 (156) [164] BO or remove the remaining sts. on W.Y. Bring sts. on the left back into WP. Turn counter back to 142 (150) [158] and complete the left side. Follow instructions from \*.

**NECK BAND:** Make 1. CLOSE ONE SHOULDER first.

K1/P1 rib: Use 1 strand Col. 1 and 1 strand Col. 3 together for ribbing. Cast on 85 (89) [93] sts. After selvedge knit 22 rows. Pick up first row to form hem and with wrong side facing hang neck opening onto these ndls. and BO.

**SLEEVES:** Close second shoulder. Bring 85 (90) [95] ndls. to WP. With wrong side facing hang sleeve opening onto these ndls. using W.Y. markers as a guide. With Col. 1, from left to right 'e' cast on over these ndls. and continue in St. St. On each side dec. 1 st. every 7 rows 15 (16) [17] x. Pattern as follows: Col. 1 knit 10 rows. Col. 1 and Col. 2 knit 8 (10)

[12] Fair Isle. Col. 1 knit 10 rows Col. 2 knit 10 rows Col. 1 knit 10 rows Col. 2 knit 10 rows Col. 1 knit 10 rows setting Isle pattern on last row. Col. 1 and Col. 2 knit 8 [12] rows in Fair Isle. Cancel Fair Isle Col. 1 knit 10 rows Col. 2 knit 10 rows Col. 1 knit 10 rows Col. 2 knit 10 rows After R 116 (120) [124] rem remaining sts. on W.Y.

**SLEEVE CUFFS:** K1/P1 rib: With Col. 1 Col. 3 cast on 55 (59) [63] After selvedge knit 20 r With Wrong side facing l open sts. of sleeve onto t ndls. and BO.

**WAIST BANDS:** K1/P1 Rib: Cast on wit strand Col. 1 and 1 strand C 83 (89) [95] sts. After selve knit 24 Rows. With wrong facing hang Front/Back e these ndls. decreasing eve across and BO.

**FINISHING:** See General Instructions. Join 10 row slit in fr opposite single motif.

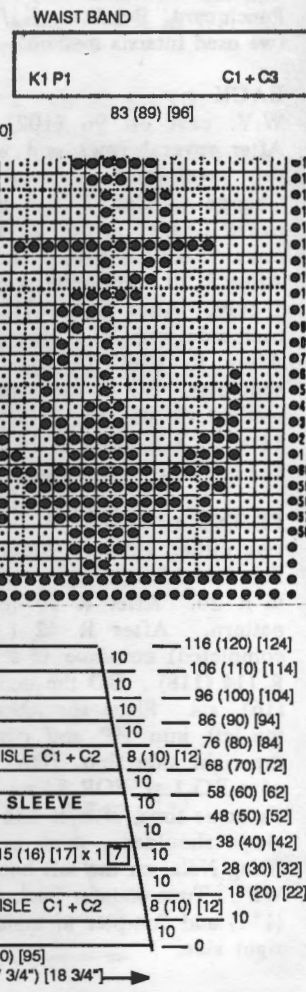

# 676

## WOMENS 2 PIECE DRESS

**YARN:** Venetia, Glace, and Mirage

**SIZES:** 8/10 (12/14) [16]

**AMOUNT:**

Col. 1- Ven. 2 cones all sizes

Col. 2- Glace 2 cones all sizes

Col. 3- Mirage 2 spools all sizes

**KIT PRICE:** \$102.00

**NOTIONS:** Beaded trim. Add an additional \$25.00 to kit price. Can be purchased separately.

**TENSION:** T 10, FNR 1/1 I, and K1/P1 T2/2 II

**GAUGE:** 13 sts. 18.5 rows = 2" (5 cm.)

Make on any Standard or Electronic machine with Ribber and Plating ability.

### TOP BACK:

W.Y. cast on 136 (142) [148] sts. After several rows, end with 1 row ravel cord to the right. With Col. 2 and Col. 3 together in the main feeder and Col. 1 in plating feeder continue in st. st. plating. After R 94 (100) [106] shape armhole. On each side BO 3 (4) [5] sts. 1 x, 3 sts. 1 x, 2 sts. 1 x, 1 st. 9 x. After R 182 (192) [202] BO the center 42 (44) [46] sts. Place the remaining sts. on the left into HP and complete the right side first. \*On neck edge BO 1 St. EOR 2 x. After R 186 (196) [206] BO or remove remaining sts. on W.Y. Bring sts. on the left back into WP. Turn counter back to R182 (192) [202] and complete the right side. Follow Instructions from \*.

### FRONT:

Same as back to R 170 (178) [186]. Shape neck opening. BO the center 38 (40) [42] sts. Place the remaining sts. on the left into HP and complete the right side first. \*On neck edge, dec. 1 st. EOR 4 x. After R 186 (196) [206] BO or remove the remaining sts. on W.Y. Bring the sts. on the left back into WP. Turn counter back to R170 (178) [186] and complete the right side. Follow Instructions from \*.

### WAIST BANDS: Make 2.

K1/P1 rib: With Col. 1 cast on 163 (171) [179] sts. After selvedge, at T 2/2 II, knit 60 rows. Transfer rib sts. to the MB. With Wrong side facing, hang open sts. of Front/Back onto these ndls. INCREASING evenly across. (pick up loop from row below to fill in the empty spaces). BO.

### NECK BAND:

FNR: With Col. 1 cast on 116 (122) [128] sts. After selvedge, knit 10 rows. Transfer rib sts. to MB and knit 1 row across. Remove on W.Y.

### SLEEVES: Make 2.

W.Y. cast on 98 (102) [106] sts. same as Front/Back. With Col. 2 and Col. 3 in main feeder and Col. 1 in plating feeder, continue in st. st. ON EACH SIDE Inc. 1 st. every 8 rows, 8 (9) [10] x. After R 76 (80) [84] shape sleeve cap. On each side BO 3 (4) [5] sts, 1 x, 3 sts. 1 x, 2 sts. 1 x, 1 st. 4 x, 1 st. every 4 rows, 3 (4) [5]x, 1 st. EOR 30 x, 2 sts. EOR 3 x. After R 168 (176) [184] BO the remaining sts.

### SLEEVE CUFFS:

K1/P1 rib: With Col. 1 cast on 69 (73) [77] sts. After selvedge knit 60 rows. Transfer rib sts. to MB and with wrong side facing, hang open sts. of sleeve onto these ndls. decreasing evenly across. BO.

### SKIRT: Make 1.

W.Y. cast on 179 (185) [191] sts. After several rows, end with 1 row ravel cord to the right. Change to Garment Yarn, (Col. 2 in Main Feeder and Col. 1 in plating feeder, knit 6 rows. Begin short rows. Turn counter off. \* Bring all ndls. to HP. Push back to WP 50 ndls. 1 x, then 25 ndls. 1 x, and 5 ndls. 1 x. Next bring to HP 20 ndls. 1 x. Turn counter on and knit 10 rows over all sts. \* Repeat from \* to \* for a total of 39 (41) [43] x ending with 3 Rows over all ndls. Remove on W.Y.

### SKIRT BAND: Make 2.

BRING TO WP 124 (130) [136] ndls. With wrong side facing hang 1/2 of skirt waist onto these ndls. Knit 36 rows. Hang first row to form hem and bind off.

### FINISHING:

See General Instructions. Close shoulders. Weave neck band to neck opening. Set in sleeves and weave side seam of skirt. Crochet 2 rows single crochet around skirt bottom with 1 strand of Col. 2. Sew on beaded trim (see picture).



676 Beautifully Simple

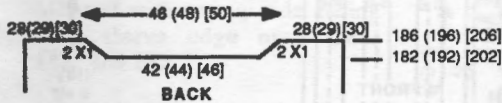

BACK

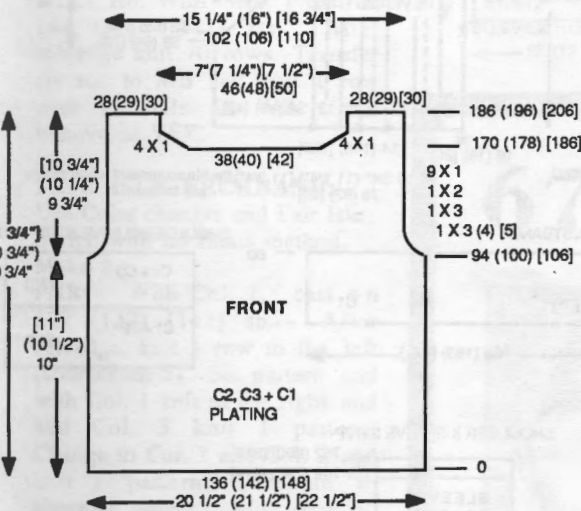

FRONT

C2, C3 + C1 PLATING

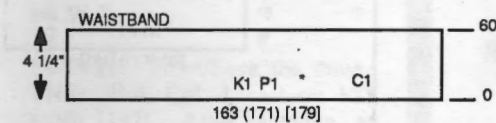

WAISTBAND

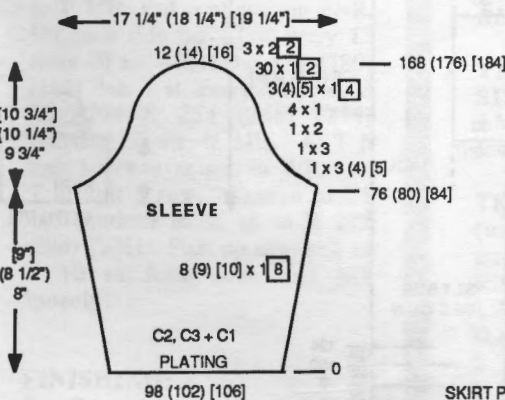

SLEEVE

C2, C3 + C1 PLATING

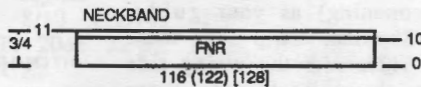

NECKBAND

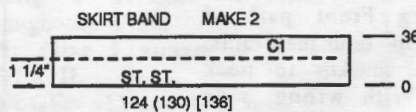

SKIRT BAND MAKE 2

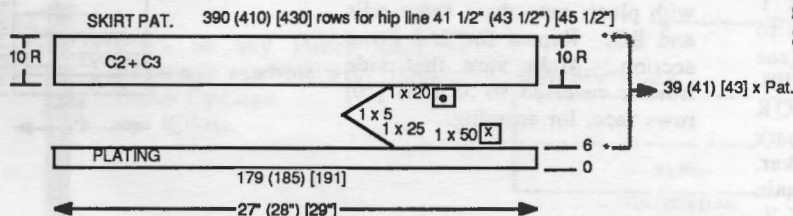

SKIRT PAT. 390(410)[430] rows for hip line 41 1/2" (43 1/2") [45 1/2"]

179(185)[191]

27" (28") [29"]

**SLEEVES:**

Close both shoulders first. Bring 118 (124) [130] ndls. to WP. With wrong side facing hang sleeve opening onto these ndls. using W.Y. markers as your guide. Pull all ndls. to HP. and close the latches. With regular carr. at T 10 knit 1 row st. st. from left to right. Counter at -0-. Change to Garter Carr. and continue in pattern. On each side dec. 1 st. every 7 rows 14x. 1 st. every 8th row 1x, (1 st. every 7 rows 14 x, 1st. every 6 rows 2x) [1 st. every 7 rows 12 x, 1 st. every 6 rows 5x]. After R 106 (110) [114] BO or remove remaining sts. on WY.

**SLEEVE CUFFS:** Regular Ribber. (1 strand only)

(If using garter carr. to make the ribbing, use 1 strand yarn and pattern #532 or punch card and use T 2.)

K1/P1 rib: Cast on 69 (73) [77], sts. After selvedge knit 60 rows. Transfer rib sts. to MB, pick up first row to form hem and with wrong side facing hang open sts. of sleeve edge onto these ndls. BO.

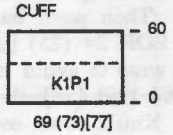
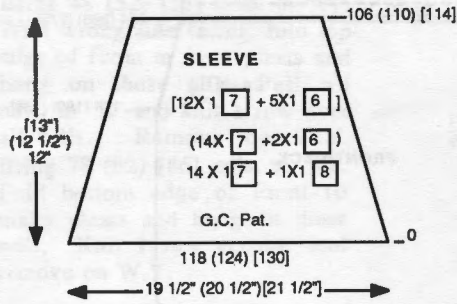

Repeat through R 48 then 2 rows of holes for joining

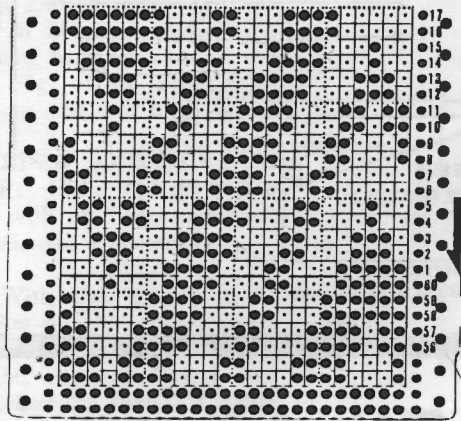

**WAIST BANDS:**

K1/P1 rib: Cast on 121 (127) [133] sts. After selvedge knit 80 rows. Transfer rib sts. to MB. Pick up first row to form hem and with wrong side facing hang open sts. of sleeve onto these ndls. BO.

**FINISHING:**

See General Instructions. Close neck band if desired or leave open. Band curls naturally.

PAT. No. 470 from Computnit III Book

**679**



**WOMENS PLATED TOP**

**YARN:** Glace and Venetia  
**SIZES:** 6/8 (10/12) [14]  
**AMOUNT:**  
 Col. 1-Br. Glace 1 cone all sizes  
 Col. 2-Gr. Glace 1 cone all sizes  
 Col. 3-Br. Ven. 1 cone all sizes  
 Col. 4-Gr. Ven 8 oz. all sizes  
 Col. 5-Br. Isabella - 1 spool (Very small amount)  
**KIT PRICE:** \$77.00  
**NOTIONS:** Snakeskin Trim  
 Add \$20.00 to kit price.

**TENSION:** Plating T 10, Ribber T 5/5 I.  
**GAUGE:** 14 sts. 19.5 rows = 2" (5cm)

Make on any Standard or Electronic Machine with Ribber and plating ability.

**FRONT/BACK:** The same.  
 To the right of -0- W.Y. cast on 78 (80) [82] sts. After several rows, end with 1 row Ravel Cord to the right. Change to Garment yarn. With Col. 1 in main feeder and Col. 3 in plating feeder continue in plating technique. On left side, inc. 1 st. every 10 rows 9 (10) [11] x. After R102 (110) [120] begin decreases for front -V-. Dec. 1 st. EVERY row 105 x. BUT AT THE SAME TIME on the left, after R 106 (110) [114], inc. 1 st. EOR 5 x. After R116 (120) [124], on the left cast on 46 (50) [54] sts. After R 207 (215) [225] mark for center and inc. 1 st. EVERY row 105 x. BUT AT THE SAME TIME after R 297 (311) [325] BO 46 (50) [54] sts. at the same time BO 1 st. EOR 5x on sleeve edge. Then Dec. 1 st. every 10 rows 9 (10) [11] x. After row 414 (430) [450] remove on W.Y.

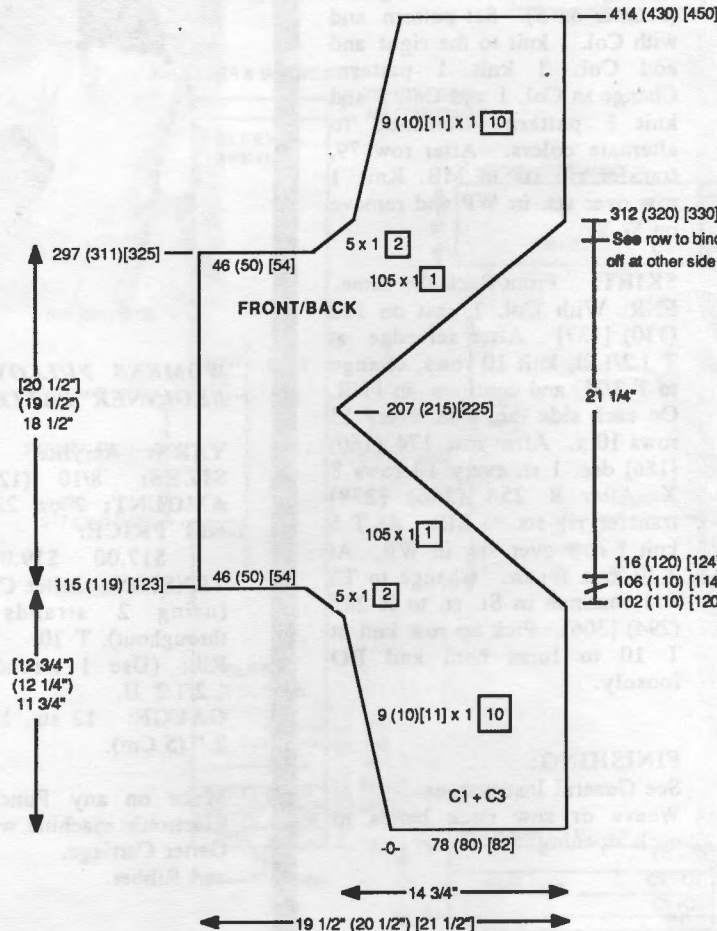

**FRONT-V-INSERT:** Make 1.  
 Note: Before you start you may want to make a 52 st. cast-on rag to be used for the 52 st. and 2 cast on rags of 44 (43) [42] sts. Starting at ndl. no. 76 to the left of -0-, hang the cast-on rag on 44 (43) [42]. With Col. 2 in main feeder and Col. 4 in plating feeder begin plating. On the left decrease 1 St. EOR 69 x, 1 st. every row 6x. **AT THE SAME TIME** on the right, inc. 1 st. EOR 6 (7) [8] x. After R 14 (16) [18] with Ravel Cord, knit all ndls back to 'A' position. Starting at ndl. 76 to the right of -0- cast on with cast on rag 44 (43) [42] sts. Change to garment yarn and continue in Plating. On the right dec. 1 st. EOR 69 x, 1 st. every row 6 x. **AND AT THE SAME TIME** on the left, dec. 1 st. EOR 6 (7) [8] x. After R 14 (16) [18], hang cast on rag over the center 52 ndls. bring needles from A position to B position. Continue in plating over all sts. (Remember the decreases on each side.) and after R 146 BO the remaining sts.

**BACK-V-INSERT:** Make 1.  
 NOTE: You may want to make a 58 (60) [62] st. cast-on rag to be used for the center 58 (60) [62]. Starting at ndl. no. 76 to the left of -0-, with wrong side facing hang shoulder sts. of front on 44 (43) [42] sts. On the left Dec. 1 st. EOR 69 x, 1 st. Every row 6 x. **AT THE SAME TIME** on the neck edge Inc. 1 st. EOR 3 x. After R 8 with Ravel Cord knit all needles to 'A' position. Starting at ndl. no. 76 to the right of -0-, knit to match the left side, reversing all shaping. After R 8 hang cast on rag onto 58 (60) [62] st. in the center and continue over all sts. in plating. After R 146 BO the remaining 2 sts.

**WAIST BANDS:** Make 2.  
 Note: The Waist Band is made using the plating attachment on the Ribber. See Manual if you are not familiar with this technique. Using Col. 1 in main feeder and Col. 3 in plating feeder, cast on 131 (139) [147] sts. Knit 50 rows. Transfer rib sts. to MB and with wrong side facing hang bottom edge of of Front/Back onto these ndls. BO.

**SLEEVE CUFFS:**  
 Cast on, same as Waist Band, 63 (67) [71] sts. same as waist band and knit 50 rows. Transfer rib sts. to MB and with wrong side facing hang open sts. of sleeve edge onto these ndls. decreasing evenly across. BO.

**FINISHING:**  
 See General Instructions. Join -V- insert to front/back. Before closing apply snakeskin appliques using paper underneath. (See picture). With 2 strands Col. 2 crochet 1 row single crochet then 1 row reverse single crochet around neckline. Embroider stems with Col. 5. Front strips of snakeskin are repeated on the Back. Picture applique is only on the Front.

Diagram

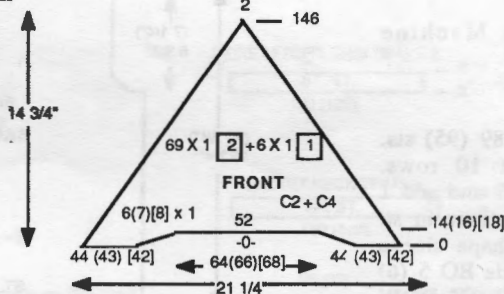
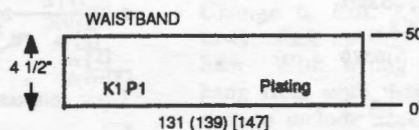
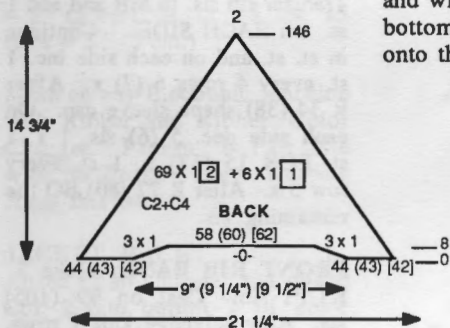
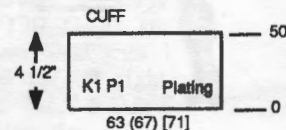

## LECTROLINK + YOU = LINKING MADE EASY

You can now assemble your knitted garments in record time. The **Lectrolink** is fast and incredibly easy-to-operate. It not only seams garment pieces, but performs additional functions such as *shirring, gathering and creative stitching!*

You will be delighted with the tremendous time and professional look that you will achieve with the **Lectrolink**.

Its 220-needle circular construction allows for continuous feeding of any length garment. Control of tension and linking speed allows you to execute a perfectly even crochet chain stitch seam in fine to medium weight yarns

Finishing, applique, ornamental chain stitch, piping, elastic shirring....*It's all at your fingertips with the amazing Lectrolink.*

It truly is professional finishing made easy!



## WOMENS 2 PC. DRESS

**YARN:** Bulky Venetia

**SIZES:** 6/8 (10/12)

**AMOUNT:** 27 oz. 29 oz.

**KIT PRICE:** \$24.00 \$26.00

**TENSION:** Top 4.1, Skirt bottom T 4.1, Skirt Top 4.4.

Top Waist bands 1.1/1 I, Sleeve rib 0.1/0 I.

**GAUGE:** 9.5 sts. and 13.5 rows = 2" (5 cm).

**NOTIONS:** Ten decorative buttons for the front.

Make on any Bulky Machine with Ribber.

### TOP BACK:

K1/P1 rib: Cast on 89 (95) sts. After selvedge knit 10 rows. Transfer rib sts to MB and add 1 st. on the right. Continue in st. st. After R 94 (98) shape sleeve opening. On each side BO 5 (6) sts. 1 x, then 1 st. EVERY ROW 5 x. After R 140 (148) shape shoulders. BO or use short row method. 6 st. 3 x, (6 sts. 2 x, 7 sts. 1 x). After R 146 (154) mark with W.Y. for neck opening and BO or remove on W.Y.

### TOP FRONT:

Same as back to R 130 (136). Shape neck opening. BO the center 14 (16) sts. Place the sts. on the left into HP and complete the right side first. \*On neck edge dec. 1 st. every row 10 x. After R 140 (148) shape shoulders same as Back. After completing right side, bring ndls. on the left back to R 130 (136) into WP. Turn counter back and complete the left half. Follow Instructions from \*.

### NECK BAND:

Close 1 shoulder first.

K1/P1 rib: Cast on 69 (73) sts. After selvedge knit 8 rows.

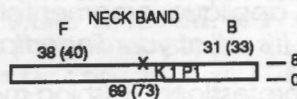
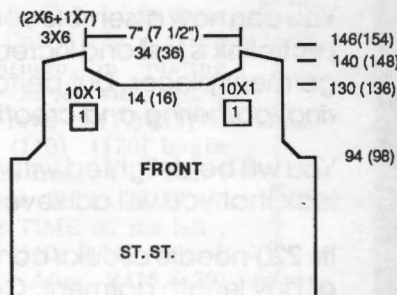
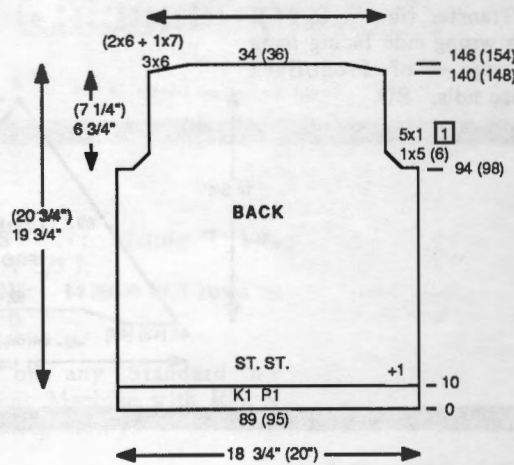
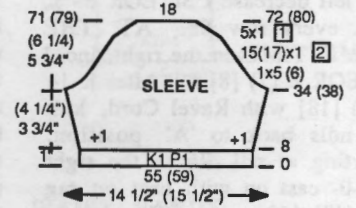
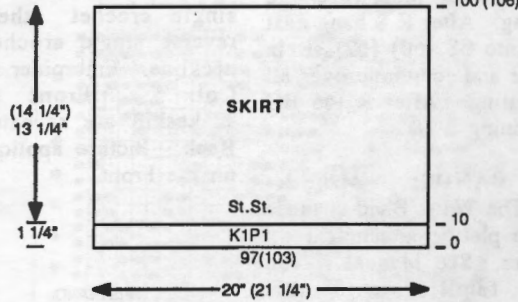
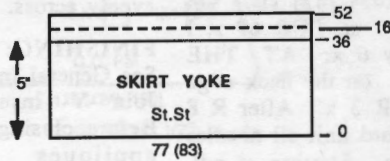
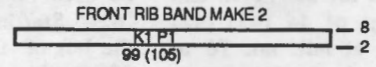

Transfer rib sts. to MB. Mark with W.Y. (see chart) for Front/Back placement. With wrong side facing hang neck opening onto these ndls. and BO. Close second shoulder.

### SLEEVES:

K1/P1 rib: Cast on 55 (59) sts. After selvedge knit 8 rows. Transfer rib sts. to MB and add 1 st. on EACH SIDE. Continue in st. st. and on each side inc. 1 st. every 4 rows 6 (7) x. After R 34 (38) shape sleeve cap. On each side dec. 5 (6) sts. 1 x, 1 st. EOR 15 (17) x, 1 st. every row 5 x. After R 72 (80) BO the remaining sts.

### FRONT RIB BAND: Make 2.

K1/P1 rib: Cast on 99 (105) sts. After selvedge knit 7 rows. At T 8 knit 1 additional row and BO loosely.

### SKIRT: Made in 2 sections.

#### LOWER SKIRT: Make 2.

K1/P1 rib: Cast on 97 (103) sts. After selvedge knit 10 rows. Transfer rib sts. to MB and continue in st. st. After R 100 (106) remove on W.Y.

#### SKIRT YOKE: Make 2.

Bring 77 (83) ndls. to WP. With wrong side facing, hang open sts. of lower skirt sections onto these ndls., decreasing evenly across. Counter at -0-. Knit 36 rows. Knit 1 additional row at T 8. Knit to R 52. Pick up loose row to form hem and BO.

### FINISHING:

See General Instructions.

Join side seams of Top and set in sleeves. Hand stitch Front Rib Band (cast on edge) to Front, using shoulder edge as guide. Sew on Buttons. (See photo).



## 681 Striking Beauty



### WOMENS 3 PC. ENSEMBLE

**YARN:** Col. 1 - Fine Venetia  
Col. 2 - Antique Gold Metallic

**SIZES:** 10/12 (14)

#### AMOUNT:

Col. 1 2 cones both sizes  
Col. 2 2 large cones both sizes  
**KIT PRICE:** \$80.00  
**TENSION:** FNR double knit T 4/4 lili, St. st. T 2.1  
**GAUGE:** FNR 18 sts. 44 rows = 2" (5 cm). St. st. 19 sts. 25 rows = 2" (5 cm).

Make on any Electronic machine with Ribber and Ribber Color Changer. Pattern is Fair Isle with no floats. (See Knitting Hints this issue.)

#### JACKET BACK:

Attach Color Changer and thread Col. 2 into button 2 of color changer. Leave Col. 1 for regular cast on.

FNR: With Col. 1 cast on 156 (166) sts. After selvedge, at T 2/2 II knit 10 rows. Knit 1 row to the left. Set Pattern No. 1 and with KC II setting, knit 1 row to the right to select needles. Set carriages for double knit and continue in pattern. On each side inc. 1 st. every 20 rows 9 (10) x. After R 204 (216), on each side dec. 1 st. EOR 24 (26) x. After R 408 (430) transfer rib sts. to MB. Mark the back neck opening with W.Y. markers, (see chart) and BO.

#### JACKET FRONT:

Reverse 1.  
**NOTE:** Be sure to cast on either from -0- to the right or -0- to the left. On one side use the reverse Key (1) to reverse the pattern. This will make the pattern match perfectly in the center.

FNR: with Col. 1 (to the right of -0- cast on 78 (84) sts. and continue same as back. After R 10, set pattern no. 1 and continue as for Back. On right side inc. 2 sts. every 40 rows 4 x. (2 sts. every 40 rows 5 x). After R 204 (216) on armhole side BO 2 sts. every 4 rows 12 (13) x. After R 352 (370) shape neck. BO 6 (10 sts.) 1 x, 4 sts. every 4 rows 1 x, 2 sts. every 4 rows 8 x. After R 408 (430) BO the remaining sts.

#### SLEEVES:

FNR: With Col. 1 cast on 60 (68) sts. same as before. After R 10 set pattern No. 1. (For second sleeve use Variation key 1 to reverse pattern.) Continue as before. On each side inc. 1

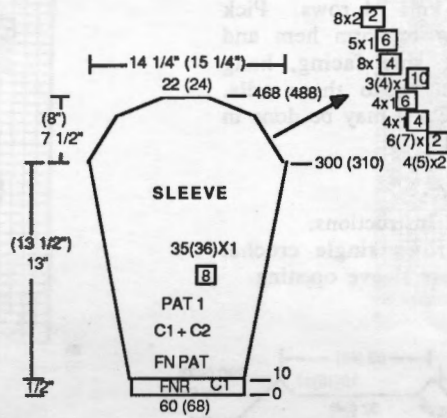

st. every 8 rows 35 (36)x. After R 300 (310) shape sleeve cap. On each side BO 2 sts. 4 (5) x, 1 st. EOR 6 (7) x, 1 st. every 4 rows 4 x, 1 st. every 6 rows 4 x, 1 st. every 10 rows 3 (4) x, 1 st. every 4 rows 8 x, 1 st. every 6 rows 5 x, 2 sts. EOR 8 x. After R 468 (488) transfer rib sts. to MB and BO.

#### JACKET NECK TRIM:

Make 1.

Close both shoulders first. W.Y. cast on 130 (140) sts. After several rows, end with 1 row Ravel Cord to the right. Change to Col. 2. At T 3 knit 6 rows st. st. Pick up first row to form hem. With wrong side facing, hang neck opening onto these ndls. and BO.

#### JACKET FRONT TRIM:

Make 2.

W.Y. cast on 120 (127) sts. Change to Col. 2, T 3, knit 6 rows. Pick up first row to form hem. With wrong side facing hang front onto these ndls. (Be sure to include neck trim.) and BO.

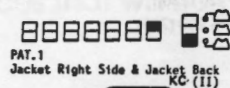
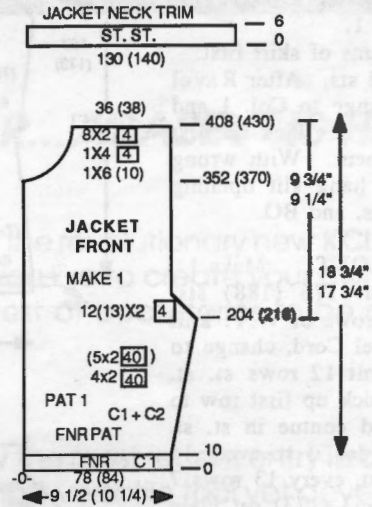
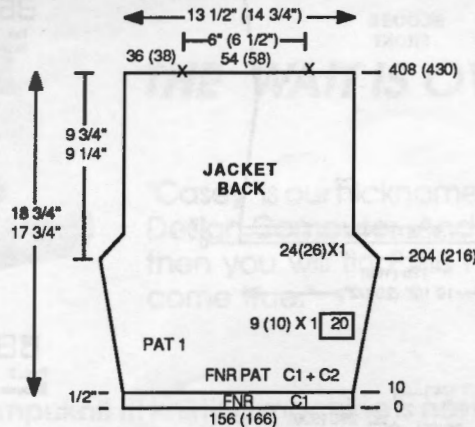
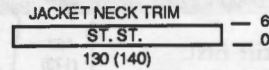
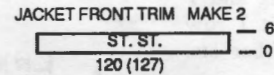

1111 Buttons

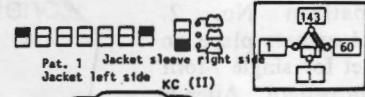
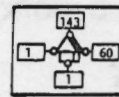

1111 buttons

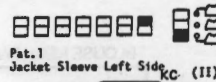

1111 Buttons

**SKIRT:** Make 2. (1 with rose motif and 1 without) Knitted from Waist to Lower edge. W.Y. cast on 158 (168) sts. After several rows, end with 1 row Ravel Cord to the right. Change to Col. 1 and knit 36 rows st. st. Pick up first row to form hem. Bring Ribber into knitting position. Set Ribber to H and bring corresponding ribber ndls. to WP. At T 4/4 lili, knit 1 row to the left. Hang ribber cast on comb and add wights. Knit 2 rows. Set Pat. 3, knit to the right to select ndls. Set carriages and continue in double knit. On each side inc. 1 st. every 12 rows 10 x. After R 366 (386), on the right side, mark for opening. Knit to R 410 (420) and dec. 2 sts. every 30 rows 1 x, 2 sts. every 24 rows 1 x, 2 sts. every 20 rows 1 x, 2 sts. every 16 rows 1 x, 2 sts. every 12 rows 1 x, 2 sts. every 10 rows 1 x, 2 sts. every 4 rows 1 x. But at the same time, after R 411 (431), carr. on the left. Set Pat 2 A (Compuknit III owners set on Green 33 (38). Press Variation Key #5). After R 543 (562) set Pat. 3 and continue to R 587 (607). Cancel pattern 3. With carriages at normal setting and T 5/5 lili, with Col. 1 knit 1 row to the right. Transfer ribber sts. to the MB and BO.

**TRIM FOR SKIRT SIDE SLIT:** Make 1.

Close side seams of skirt first. W.Y. cast 170 sts. After Ravel Cord row change to Col. 1 and knit 6 rows st. st. Pick up first row to form hem. With wrong side facing, hang slit opening onto these ndls. and BO.

**BLOUSE FRONT:** Make 1. W.Y. cast on 176 (188) sts. After several rows of W.Y. knit 1 row of Ravel Cord, change to Col. 2 and knit 12 rows st. st. After R 12, pick up first row to form hem and continue in st. st. After R 12, pick up first row to form hem and continue in st. st. On each side dec. 1 st. every 14 rows 6 x, (1 st. every 13 rows 7 x). After R 163 (173) set Plain Fair Isle pattern No. 2. (Compuknit III owners place on Yellow 50.) Set for single Motif and continue in pattern. After R 200 (206) shape armhole. On each side BO 5 (6) sts. 1x, 4 sts. 1 x, 1 st. every row 10 x, 1 st. EOR 38 x, (1 st. every row 12 x, 1 st. EOR 49 x. AFTER R 260 (266) shape neck opening. BO the center 32 (34) sts. Place the sts. on the left into HP and complete the right side first.

\*On neck edge dec. 1 st. EOR 15 (16) x. After R 290 (300) bring the ndls. on the left back into WP. Turn counter back to R 260 (266) and complete the right side. Follow Instructions from \*.  
opening. Place the sts. to the left of -0- into HP and complete the right side first. \*Knit to R 280 (290). Remember the decreases on both sides. On the left BO 26 (28) sts. for neck opening. Then on neck edge dec. 1 st. EOR 5x. After R 290 (300) bring the ndls. on the left back into WP. Turn Row Counter back to 220 (230) and complete the left side. Follow Instructions from \*.

**BLOUSE NECK BAND:**

W.Y. cast on 116 (126) sts. After Ravel Cord row change to Col. 2 and knit 74 rows. Pick up first row to form hem and with wrong side facing, hang neck opening onto these ndls. BO. (NOTE: It may be done in sections.)

**FINISHING:**

See General Instructions. Crochet 2 rows single crochet around Blouse sleeve opening.

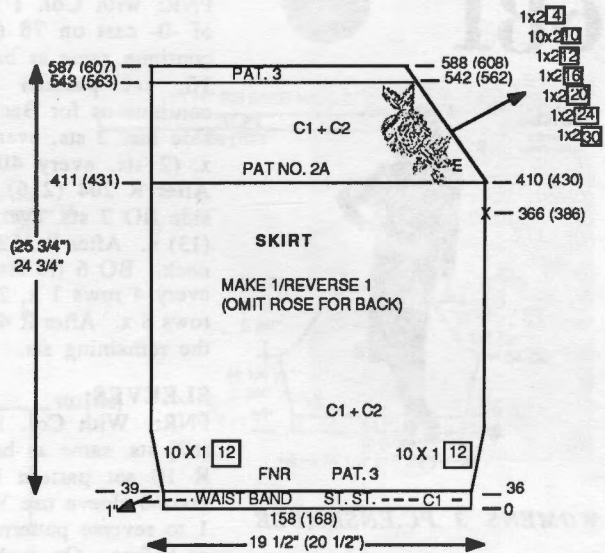
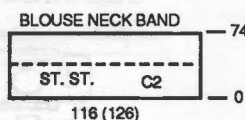
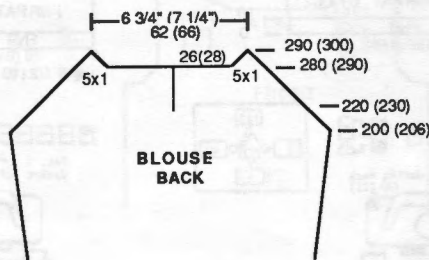
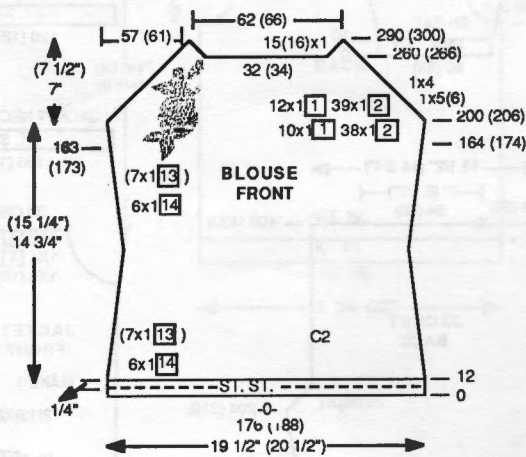

910 Owners

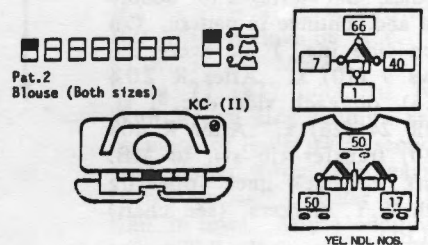
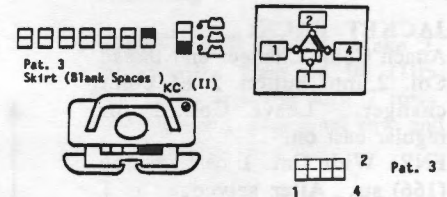
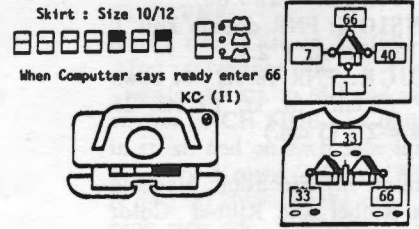

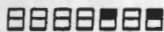

When Computer says ready enter 66.

KC (II)

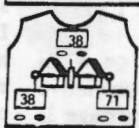
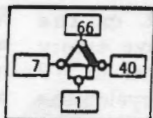

GRN. NDL. NOS.

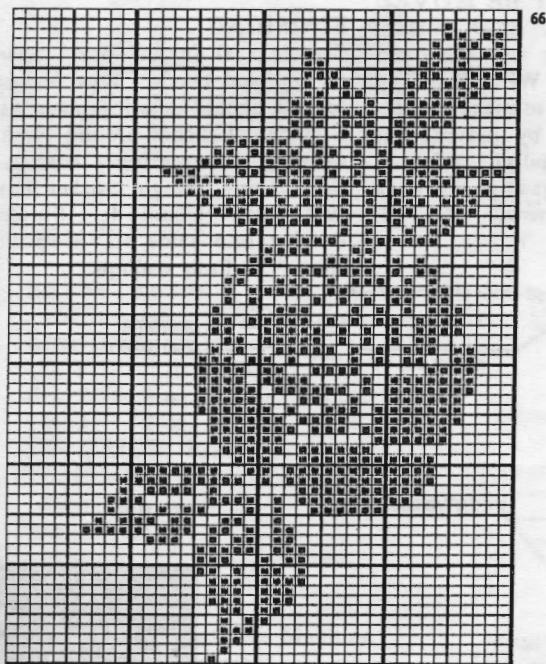

Pat. 2 & 2A

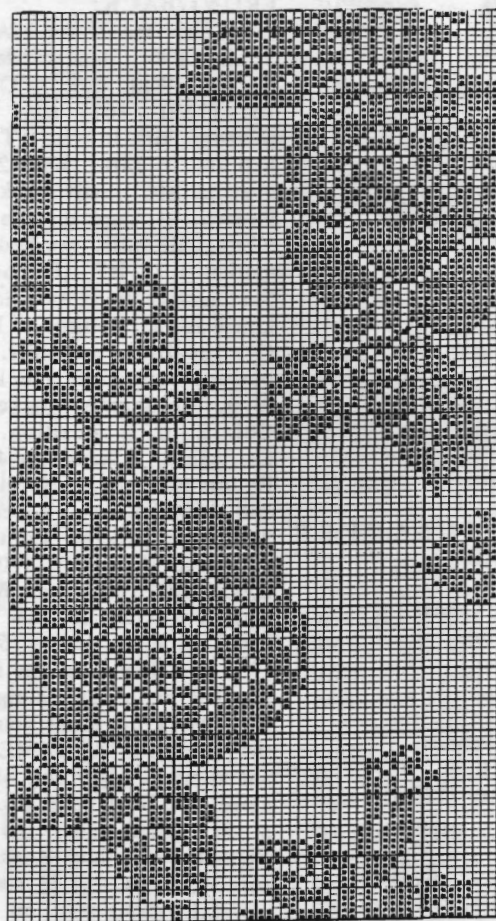

Pat. 1



### THE WAIT IS OVER... "CASEY" IS HERE !!!

"Casey" is our nickname for the revolutionary new KCIII Pattern Design Computer. And, if you like to create your own designs, then you will find this newest of accessories to be a "dream come true."

This accessory for your **Compuknit III** knitting machine is not only the most recent entry in a long line of innovative products from KNITKING -- It is quite possibly the most versatile tool yet developed for creating the design masterpieces that will truly astound your friends.

By turning your color television set into a knitwear design studio, you can indulge all of your creative fancies, while at the same time make fine-tuning adjustments in your beautiful designs with the push of a button. Then, you can experiment with different yarn color combinations *right on your T.V. screen!*

You can read more about "Casey" on the back cover of this magazine. But don't hesitate...order your very own **KCIII** today and take advantage of our low introductory price of \$449.95. The sky is the limit!



682  
Pleasant  
Petals

## WOMENS PULLOVER WITH LEAVES

- YARN:** Ice Cream  
 Col. 1: White  
 Col. 2: Grey  
 Col. 3: Pink  
 Col. 4: Blue  
 Col. 5: Lavender  
 Col. 6: Yellow
- SIZES:** 8/10 (12/14) [16]
- AMOUNT:**  
 Col. 1: 24 25 26 oz.  
 Col. 2: 1 oz. all sizes  
 Col. 3: 2 oz. all sizes  
 Col. 4: 1 oz. all sizes  
 Col. 5: 1 oz. all sizes  
 Col. 6: 1 oz. all sizes

- KIT PRICE:**  
 \$61.00 64.00 66.00
- TENSION:** T8, Rib 1/1 I
- GAUGE:** 7 1/2 9
- Front/Back: 15 sts. 18 rows=2"  
 Sleeves: 13 sts. 22 rows = 2"  
 (5 cm.)
- NOTIONS:** 7 dozen beads (not included in kit)

Make on Standard or Electronic Machine. Pat. 1 only for Electronic Machine. Pat. 2 on any Standard or Electronic Machine. Ribbing is done on standard ribber. PURL SIDE is the right side.

**TUCK PATTERN:**  
 For manual selection of ndls.: (Standard Machine).  
 With a Water Base Marking Pen, mark the needle bed as follows:  
 To the right of 0, mark ndls. 20, 40, 60, 80.  
 To the left of 0, mark ndls. 1, 21, 41, 61, 81.  
 With a different color pen, (marker 2), mark the needle bed as follows:  
 To the right of 0, mark ndls. 10, 30, 50, 70, 90.  
 To the left of 0, mark ndls. 11, 31, 41, 61, 81.

**FRONT/BACK:**  
**PATTERN MADE BY MANUAL SELECTION.** (Standard Machine)  
 K1/P1: With Col. 1, Cast on 151 (159) [167] sts. After selvedge, knit 36 rows. Transfer Rib sts. to MB. Knit 2 rows over all sts. Start Tuck Stitch Pattern, carriage on the right. \*Bring all ndls. marked with marker 1 to HP (E position). Set carriage to H position and knit 4 rows. Return to Normal (N) position so ndls. in E position will knit, and knit 14 rows. Bring ndls. marked with Col. 2 to E position. Set Carriage to H, and knit 4 rows. Return carriage to Normal (N), and knit 14 rows\*. Repeat from \* to \* for pattern. Continue in pattern to 158 (164) [170]. ON EACH SIDE, mark with W.Y. for sleeve. After R 248 (258) [268], BO the center 62 (66) [70] sts. Place sts. on the left into HP, and complete right side first (Mark the place you are in the pattern). \*\*AT SAME TIME, shape neck edge and shoulder slope. On Neck edge, decrease 1 st. 5x. On shoulder, BO or use Short Row Method, 8 sts. 5x, (8 sts. 3x, 9 sts. 2x) [8 sts. 1x, 9 sts. 4x]. Bring ndls. on the left back into WP. Turn counter back to 248 (258) [268]. Find place in pattern and complete left half. Follow instructions from \*\*.

**SLEEVES:**  
 Tuck st. with Punch card, Pat. 2. COMPUKNIT III owners use Pat. 245.  
 With Col. 1, Cast on 132 (140) [148] sts. Knit 2 rows setting Pattern on 2nd row. ON EACH SIDE, decrease 1 st. every 5 rows 23x. After R 116 (120) [124], remove remaining sts: on W.Y.

**SLEEVE CUFFS:**  
 K1/P1: With Col. 1, Cast on 75 (79) [83] sts. Knit 36 rows. Transfer Rib sts. to MB. With wrong side facing, hang open sts. of sleeve onto these ndls. decreasing evenly across. BO loosely.

**LEAF PATTERN:**  
 Make 12- 2 of colors 2, 4, 5, 6, and 4 of color 3.  
 Using ndls. 1&2 to the left of 0 and ndl. 1 to the right of 0, 'e' Cast on 3 sts. Knit 1 row to the left. Bring 1 additional ndl., carriage side, to WP and 'e' cast on this ndl. Knit 1 row to the RIGHT. Follow Chart and with 1 prong transfer tool, move st. 2 on the left to st. 3 and on the right, move st. 1 to st. 2.

(filling 1 empty ndl. on the right). ALWAYS leave empty ndls. each side of center in WP after making center eyelets on every second row. Knit 1 row to the left. Continue in this manner, always 'e' cast on when carriage is on the left, and move sts. OUT 1 ndl. when carriage is on the right. ALL STS. ON EACH SIDE OF THE CENTER EYELETS MUST BE MOVED OUT TO THE END NDL. Continue in this way until you have 21 sts. in WP. Knit 16 rows (remember to make eyelets every 2nd row by moving all sts. to the end ndls). After R 36, begin decreasing on each side every 2nd row. ON THE

RIGHT, move end st. to next ndl. and knit this st. through to make only 1 st. Make eyelet by moving all sts. right of center st. over to the end ndl. On the LEFT, move end st. over to next ndl., knit it through, then make eyelet by moving all sts. left of center over to end ndl. Continue in this manner until there are 5 sts. left. BO tightly.

**FINISHING:**  
 See General Instructions. Sew on optional beads. Sew leaves to both shoulders using photo as a guide. Crochet around Neck opening 1 row single crochet. Second row, \*single crochet into first 4 sts. Chain 4. Single crochet into same st. Repeat from \* to form scallops.

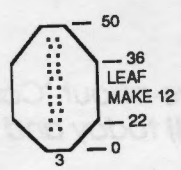
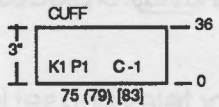
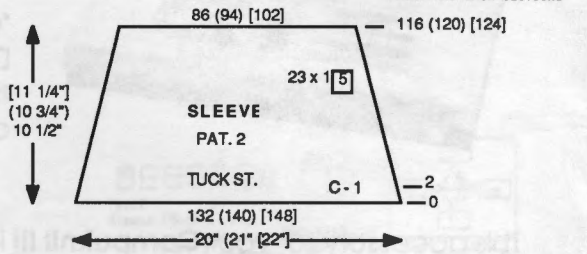
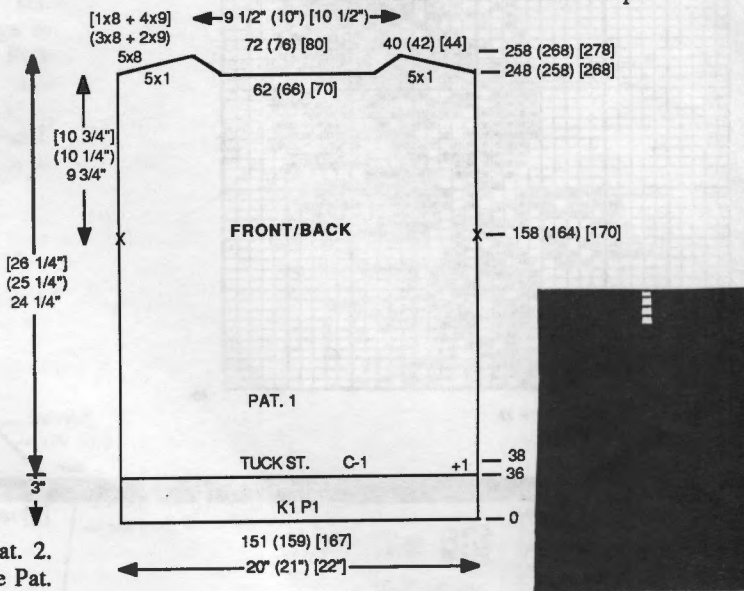

20 STS. 34 ROWS  
PAT. 1

PAT. NO. 1 FOR ELECTRONIC MACHINE  
FRONT AND BACK SECTIONS

245

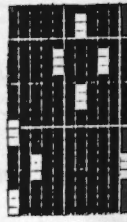

SLEEVE PATTERN  
TUCK ST. PATTERN  
12 STS. 24 ROWS.



683  
**Safari**

## GIRAFFE TOP

**YARN:** Kotton  
**SIZES:** 6/8 (10/12) [14]  
**AMOUNT:**  
 Col. 1 1 lb. all sizes  
 Col. 2 8 oz. 8 oz. 8 oz.  
 Col. 3 2 oz. 2 oz. 2 oz.  
**KIT PRICE:** \$22.00  
**TENSION:** St. st. & Fair Isle pattern T 6.  
 Rib is T 3/3 II  
**GAUGE:** 15.5 sts. 22.5 rows = 2" (5cm)

Make on any Electronic Machine with Ribber attachment. Giraffe is a Single Motif on the Front. Sleeves are a different Fair Isle pattern.

**FRONT:** Make 1.  
 Color Stripes for the ribbing are as follows.  
 4 Rows color 1  
 4 Rows color 2  
 2 Rows color 3  
 K1/P1 Rib: With Col.1 cast on 133 (139) [145] sts. After selvedge change to T 3/3 II and knit 40 rows. (Please follow color stripes - see chart.)  
 Transfer rib sts. to MB. Add 1 st. on the right. With Col. 1 continue in st. st. On each side Inc. 1 st every 14 rows 4x, 1 st. every 15 rows 2x, (1 st. every 13 rows 6x, 1 st. EVERY 12 rows 1 x), [1 st. every 12 rows 6x, 1 st. every 11 rows 2 x]. BUT AT THE SAME TIME, after R 65 (69) [73], set pattern for Giraffe. Use Single Motif settings and be sure to wrap the outside edge of pattern with separate strand of Col. 1 to prevent holes. AFTER R 126 (130) [134], on each side BO 17 sts. After R 204 (214) [224] BO the center 56 (60) [64] sts. Place the remaining sts. on the left into HP and complete the right side first. \*Knit to R244 (254) [264] and BO or remove the remaining Sts. on W.Y.

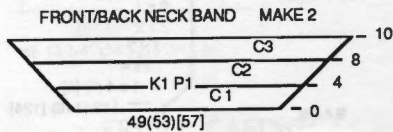
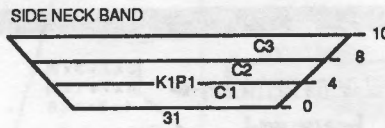
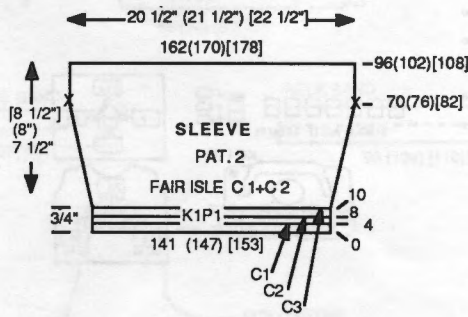
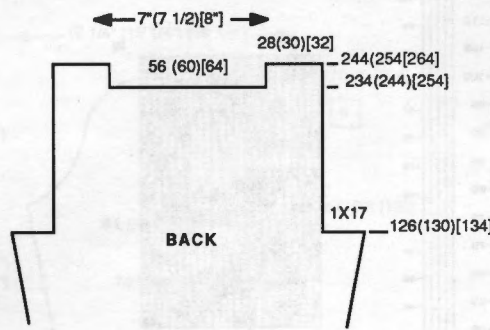

**RIB STRIPE CHART**

C3	2R	10
C2	4R	8
K1P1	4	4
C1	4R	0

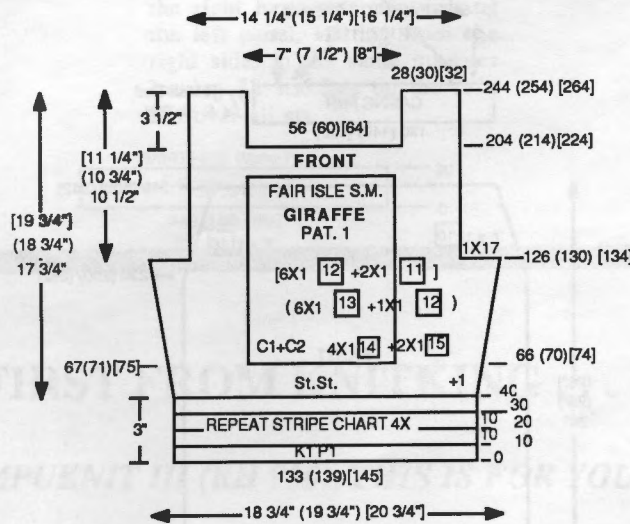

Bring Sts. on the left back into WP. Turn counter back to R 204 (214) [224] and complete the left half. Follow instructions from \*.

**BACK:** Make 1  
 Same as Front (but omit Giraffe) to row 234 (244) [254]. BO the center 56 (60) [64] sts. Place the sts. on the left into HP and complete the right side first. After R244 (254) [264] BO or remove the remaining sts. on W.Y. Bring needles on the left to W.P. Turn Row counter back to R 234 (244) [254]. Knit to R 244 (254) [264]. BO or remove on W.Y.

**SLEEVES:**  
 K1/P1 rib: With Col. 1, cast on 141 (147) [153] sts. After selvedge knit 4 Rows Col. 1, 4 Rows Col. 2, 2 Rows Col. 3. After R 10, transfer rib sts. to MB, add 1 st. on the right side, and knit 1 row across to the left with Col.1. Set Fair Isle pattern for sleeve and with Col.1 and Col. 2 continue in Fair Isle. BUT AT THE SAME TIME, on each side Inc. 1 st. every 6 rows 10 (11) [12] x. After R 70 (76) [82] mark each side for sleeve placement. After R 96 (102) [108], BO or remove on W.Y.

**NECK BANDS:**  
**FRONT/BACK:** Make 2  
 K1/P1 rib: With Col. 1, cast on 49 (53) [57] sts. After selvedge, follow color chart same as before. But at the same time on each side Inc. 1 St. EOR 4 x. After R 10, transfer rib sts. to MB. With wrong side facing, hang center Front/Back neck opening onto these ndls. and BO.

**SIDE NECK BAND:**  
 Make 2.  
**CLOSE BOTH SHOULDERS FIRST.**  
 K1/P1 rib: With Col. 1 cast on 31 sts. same as Front/Back neckbands. Continue, same as before and after Row 10, transfer rib sts. to MB. With wrong side facing, hang side of neck opening onto these ndls. and BO.

**FINISHING:**  
 See General Instructions. Weave neckband openings. We used black fabric pens to darken spots on eyes, horns, and ears for highlights.

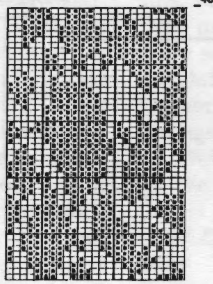
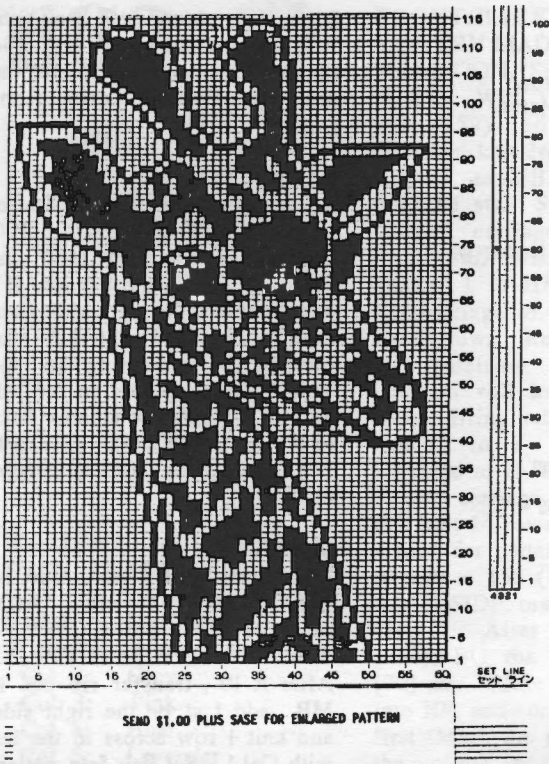

1 Pattern: 25 st. 48 rows. 25 Pat. No. 16 from Stitch World Extras

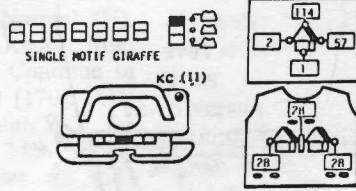

SEND \$1.00 PLUS SASE FOR ENLARGED PATTERN

# 684



684 Shape of Things to Come

## WOMENS DRESS

**YARN:** Venetia  
**SIZES:** 6/8 (10/12) [14]  
**AMOUNT:** 26 oz 28 oz 30 oz  
**KIT PRICE:**  
 \$37.00 40.00 42.00  
**TENSION:** St. st. T4  
**GAUGE:** 19 sts. 26 rows = 2" (5cm)  
**NOTIONS:** 2 small snap fasteners and 1/4" elastic for Waist Band.

Make on any Standard or Electronic Machine.

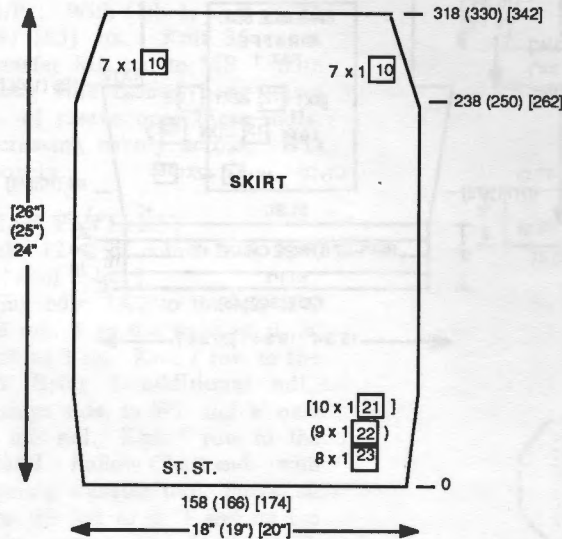
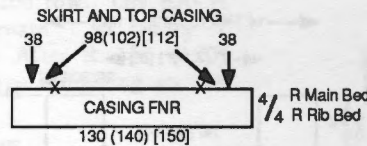
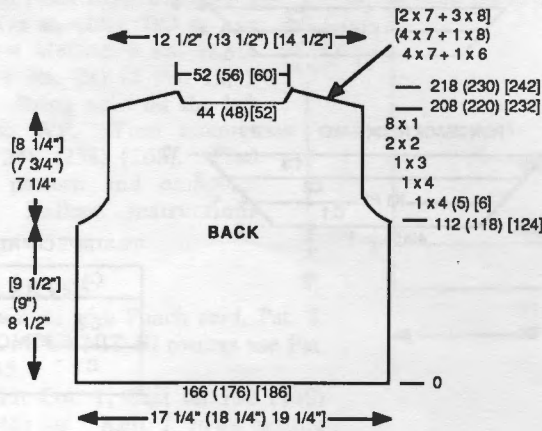

**SKIRT:** Make 2.  
 W.Y. cast on 158 (166) [174] sts. After several rows end with 1 row Ravel Cord to the right. Change to garment yarn and continue in st. st. On each side inc. 1 st. every 23 rows 8 x, (1 st. every 22 rows 9 x) [1 st. every 21 rows 10 x]. After R 238 (250) [262] on each side dec. 1 st. every 10 rows 7 x. After row 318 (330) [342] remove on W.Y.

**DRESS BACK:** Make 1.  
 W.Y. cast on 166 (176) [186] sts. same as before. Change to garment yarn and continue in st. st. After R 112 (118) [124] shape armhole. On each side BO 4 (5) [6] sts. 1x, 4 sts. 1 x, 3 sts. 1 x, 2 sts. 2 x, 1 st. 8 x. After R 208 (220) [232] shape neck opening and shoulder AT THE SAME TIME. BO the center 44 (48) [52] sts. Place the remaining sts. on the left in HP and complete the right side first.\* On the neck edge dec. 1 st. EOR 4 x. On the shoulder BO or use short row method 7 sts. 4 x, 6 sts. 1 x, (7 sts. 4 x, 8 sts. 1 x), [7 sts. 2 x, 8 sts. 3 x]. Bring the ndls. on the left back into WP. Turn counter back to R 208 (220) [232] and complete the right side. Follow instructions from \*.

**LEFT FRONT:** Make 1.  
 NOTE: In order to have the neck opening centered on -0- you must cast on as follows: Start at ndl. number 44 (46) [48] to the RIGHT OF -0-. Then cast on to the left 127 (134) [141] sts. W.Y. cast on same as before 127 (134) [141] sts. Change to garment yarn and continue in st. st. knit same as back to R 184 (194) [204]. Omit armhole shaping on the right side. ON EACH SIDE of -0-, bind off 9 (10) [11] sts. (total of 18 (20) [22] sts.) Put the needles on the left into HP and complete the right side first. \*ON NECK EDGE, BO 8 sts. 1x, 2 sts. 2x, 1 st. 5 (6) [7]x. After R218 (230) [242], remove the remaining 18 sts. onto W.Y. Bring the ndls. on the left into WP, turn Row Counter back to 184 (194) [204] and complete the left side. Follow Instructions from \* but after R 208 (220) [232] shape shoulder same as the back.

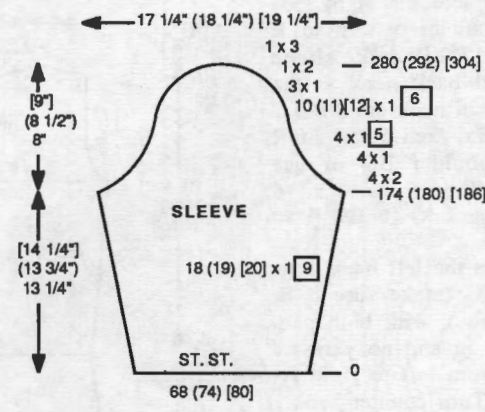
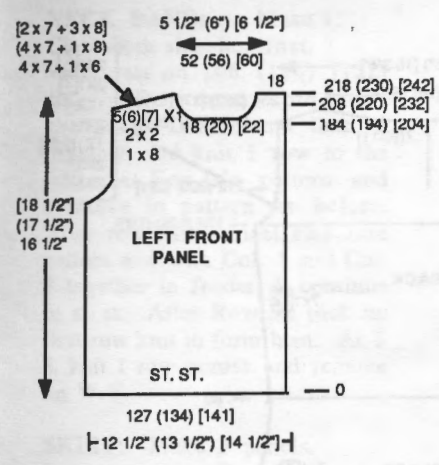

**RIGHT FRONT:** Make 1.  
W.Y. cast on 127 (134) [141] sts. Change to garment yarn and continue in st. st. On the left dec. 1 st. every 3 rows 70 (74) [78] x. After R 112 (118) [124] shape armhole same as Back. After R 208 (220) [232] shape shoulder same as Back.

**SKIRT HEM:** Make 2.  
W.Y. cast on 148 (156) [164] sts. Change to garment yarn and knit 20 rows. Pick up first row to form hem. With wrong side facing hang open sts. of skirt bottom onto these ndls. decreasing evenly across and BO.

**CASING FOR BACK**  
**WAIST:** Make 2.  
\*Bring 130 (140) [150] ndls. to WP. With right side facing hang top skirt edge onto these ndls. decreasing evenly across. Bring ribber into working position. Place setting to H. Set main bed carriage as follows. Push both Part Buttons in and knit 4 rows. Cancel Part Buttons on Main Bed. Push up both P R buttons on ribber carriage and knit 4 rows. Transfer ribber sts. to MB.\* With Wrong side facing hang open sts. of Back onto these ndls. decreasing evenly across and BO.

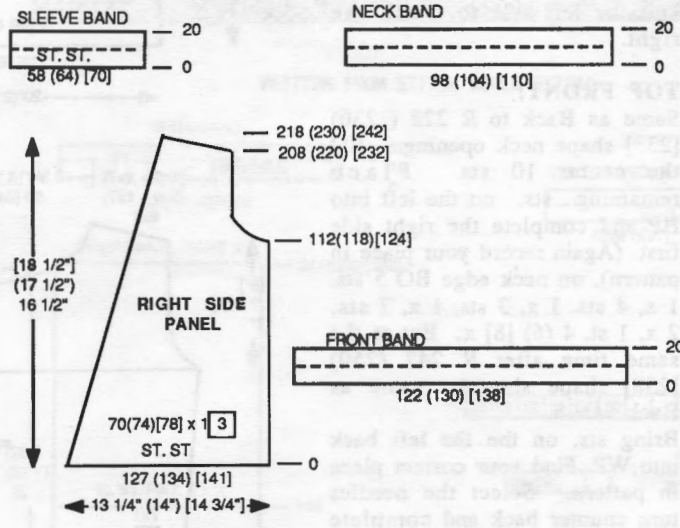

**FRONT CASING:**  
Same as back from \* to \*. With wrong side facing starting from the left side decrease 35 (32) [29] sts. out of 127 (134) [141] hang Right Panel onto 92 (102) [112] ndls. decreasing evenly across leaving 38 ndls free on the right hand side. Now hang the left panel, starting from the right side, in the same manner leaving 38 sts. free on the left. BO over all sts.

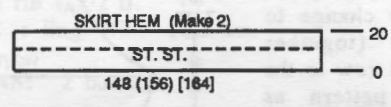

**FRONT BAND FOR RIGHT BODICE:** Make 1.  
W.Y. cast on 122 (130) [138] sts. Change to garment yarn and knit 20 rows. Pick up first row to form hem. With wrong side facing hang right side of bodice onto these ndls. and BO.

**NECK BAND:** Make 1.  
W.Y. cast on same as before 98 (104) [110] sts. Change to garment yarn and knit 20 rows. Pick up first row to form hem. With wrong side facing hang front and back neck opening onto these ndls. and BO.

**SLEEVE:**  
W.Y. cast on same as before, 68 (74) [80] sts. Change to garment yarn and continue in st. st. On each side inc. 1 st. every 9 rows 18 (19) [20] x. After R 174 (180) [186], on each side BO 2 sts. 4x, 1 st. 4x, 1 st. every 5 rows. 4 x, 1 st. every 6 rows. 10 (11) [12] x, 1 st. 3 x, 2 sts. 1x, 3 sts. 1x. After R 280 (292) [304] BO the remaining sts.

**SLEEVE BANDS:**  
W.Y. cast on same as before, 58 (64) [70] sts. Change to garment yarn and knit 20 rows. Pick up first row to form hem. With wrong side facing, hang open sts. of sleeve onto these ndls. decreasing evenly across. BO.

**FINISHING:**  
See general instructions. On the Left Front Panel sew snap fasteners on shoulder seam. String elastic through casing.

# ANOTHER FIRST FROM KNITKING ...

**IF YOU OWN A COMPUKNIT III (KH 930), THIS IS FOR YOU!!**

A Pre-Programmed Floppy Disk with all of the Pattern Stitches (except intarsia) for the garments in this issue. Just insert the disk into your Floppy Disk Drive, dial the Pattern Stitch of your choice and...AWAY YOU GO!!!

The price direct from KNITKING is \$9.95 plus \$.50 shipping.

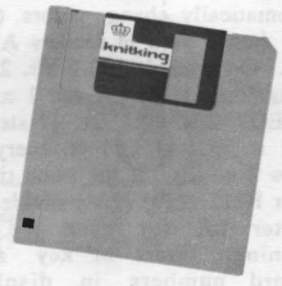



**685**  
**Incomparable**  
This new dress is knit for the  
High Neck, Full Sleeve, and  
Ankle Length. The fabric is  
a premium quality and made of the  
finest yarn. Back to the future of  
fashion design.

## WOMENS 2 PC. DRESS

**YARN:** Col. 1-Pink Venetia.  
Col. 2 - White Venetia  
Col. 3 Rainbow metallic

**SIZES:** 8/10 (12/14) [16]

**AMOUNT:**  
Col. 1 33 oz. 34 oz. 35 oz.  
Col. 2 13 oz. 14 oz. 15 oz.  
Col. 3 3 spools all sizes.

**KIT PRICE:**  
\$87.00 \$90.00 \$93.00

**TENSION:** Fair Isle pattern T 6. Skirt T 2 with Garter Carriage.

**GAUGE:** Fair Isle pattern 17 sts. 20 rows = 2"

**Notions:** 2 small buttons for back neck.

Make on the Compuknit III. Pattern is from Stitch World Extra's, 135 sts. wide and 96 rows. Skirt knitted using the Electric Garter Carriage.

**TOP BACK:**  
W.Y. cast on 174 (182) [190] sts. After several rows, end with 1 row ravel cord to the right. Change to Col. 1 and Col. 3 (used together throughout), and knit 1 row to the left. Set Fair Isle pattern and knit to the right to select ndls. Add Col. 2 in feeder B and continue in Fair Isle pattern. On each side dec. 1 st. every 8 rows 7 x. After R 80, on each side inc. 1 st. 7x every 12th row. After R 172 (176) [180] shape armhole also press Variation button 6 to automatically change colors. (do not change yarn in feeders A & B). On armhole BO 5 sts. 2 x, 3 sts. 2 x, 1 (2) [3] sts. 1 x, 1 st. EOR 2 x, 1 st. 2x, 2 sts. 1 x, 1 st. EOR 3 x, 1 st. every 4 rows 2 x. But at the same time after R212 (220) [228] divide in center for back neck opening. Press 'M' key and record numbers in display window so can return to the correct place in pattern. Place

the sts. on the left of -0- into HP and complete the right side first. Continue in pattern to R 242 (250) [258] and shape shoulder and back neck at the same time. On neck edge BO 7 (9) [11] sts. 1x, then 6 sts. EOR 3 x. On shoulder BO or use short row method 6 sts. 6 x, (6 sts. 5 x, 7 sts. 1 x) [6 sts. 4 x, 7 sts. 2 x]. Bring ndls. on the left back into WP. Press M (make sure it is the correct row.), with both part buttons press in and no yarn in feeders, go from left to right to select ndls. Turn counter back, press MC button add yarn and knit the left side to match the right.

**TOP FRONT:**  
Same as Back to R 222 (230) [238] shape neck opening. BO the center 10 sts. Place remaining sts. on the left into HP and complete the right side first. (Again record your place in pattern). on neck edge BO 5 sts. 1 x, 4 sts. 1 x, 3 sts. 1 x, 2 sts. 2 x, 1 st. 4 (6) [8] x. But at the same time after R 242 (250) [258] shape shoulder same as Back. Bring sts. on the the left back into WP. Find your correct place in pattern. Select the needles turn counter back and complete to match the right side.

**PEPLUM HEM:** Make 2. W.Y. cast on 139 (146) [152] sts. After Ravel Cord row change to Col. 1 & 3 (used together) and at T 5 knit 16 rows. Pick up first row to form hem. With wrong side facing hang open sts. from Front/Back onto these ndls. decreasing evenly across. BO

**SLEEVES:**  
W.Y. cast on 66 (68) [70] sts. After ravel cord row change to Col. 1 & Col. 3 (together through) and knit 1 row to the left. Set Fair Isle pattern as before, add Color 2 to 'B' feeder and continue in Fair Isle. On each side in. 1 st. every 3 rows 36 x, 1 st. every 4 rows 2 x, (1 st. every 3 rows 38 x, 1 st. EOR 3 x) [1 st. every 3 rows 36 x, 1 st. EOR 8 x]. After R 114 press key #6 to reverse colors. After R 116 (120) [124] shape sleeve cap. On each side dec. 5 sts. 2 x, 3 (4)[5] sts. 1 x, 3 sts 2 x, 2 sts. 3 x, 1 st. 3 x, 1 st every 4 rows 8 (9) [10] x, 1 st. EOR 7 x, 3 sts. 3 x, 5 sts. 1 x. After R 192 (200) [208] BO the remaining sts.

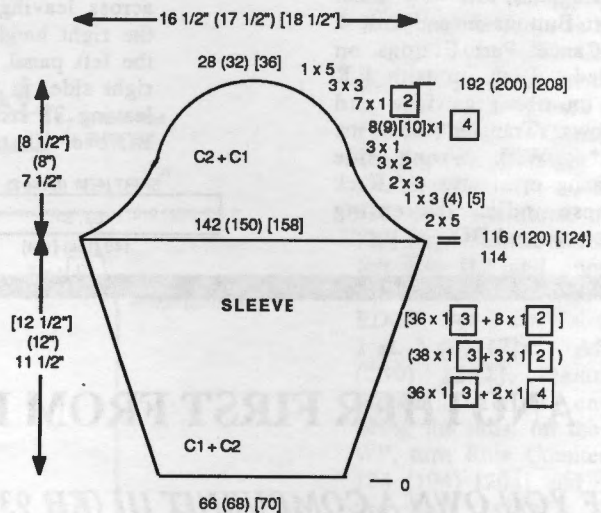
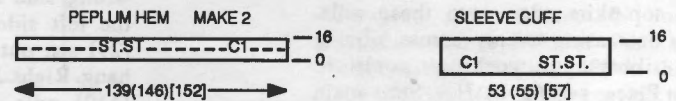
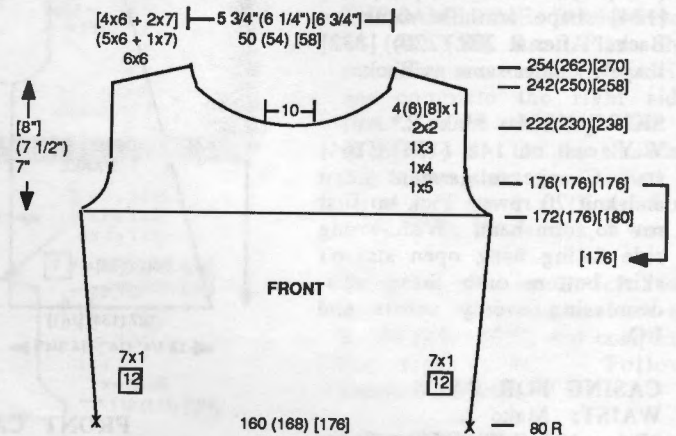
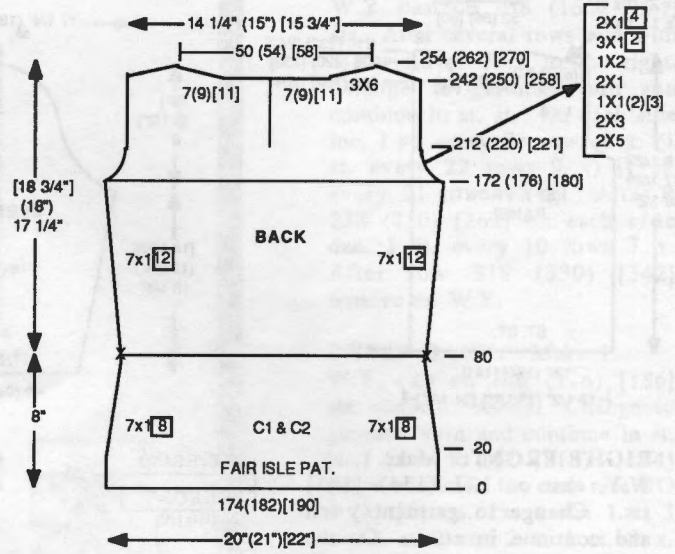

**SLEEVE BANDS:**  
W.Y. cast on 53 (55) [57] sts. After ravel cord row, change to Col. 1 & Col. 3 together and at T 5 Knit 16 rows. Pick up first row to form hem and with wrong side facing hang open sts. of sleeve onto these ndls. decreasing evenly across.



**NECK BAND:** Make 1.  
Close both shoulders first.  
W.Y. cast on 106 (114) [122]  
sts. After ravel cord row,  
change to Col. 1 and Col. 3  
together and knit 1 row to the  
left. Set Fair Isle pattern and  
continue in pattern as before.  
After row 16, cancel Fair Isle  
pattern and with Col. 1 and Col.  
3 together in feeder A continue  
in st. st. After Row 32 pick up  
first row knit to form hem. At T  
8, knit 1 row across and remove  
on W.Y.

**SKIRT:** Make 3 panels.  
Input patterns. See chart.  
Made with the Electric Garter  
Carriage.  
With Col. 1 only, cast on cast  
on 170 (182) [194] sts. Set  
pattern for 6 x 6 rib and at T2  
continue in garter st. pattern.  
After R 156, cancel 6 x 6 rib  
and set pattern for 2 x 2 rib.  
(#534) in pattern book. After R  
344 (356) [368] remove on  
W.Y.

**SKIRT WAIST BAND:**  
Make 3.  
Join the 3 panel together.  
W.Y. cast on 85 (91) [97] sts.  
After ravel cord row change to  
Col. 1 and at T 4.2 knit 34  
rows. Pick up first row to form  
hem. With wrong side facing  
hang 1/2 the skirt top onto  
these ndls. and BO.

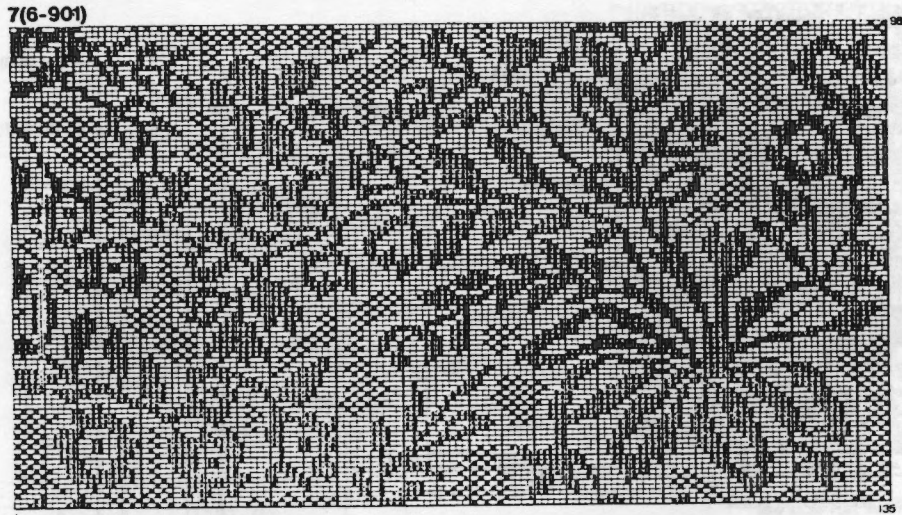

PATTERN FROM STITCH WORLD EXTRAS

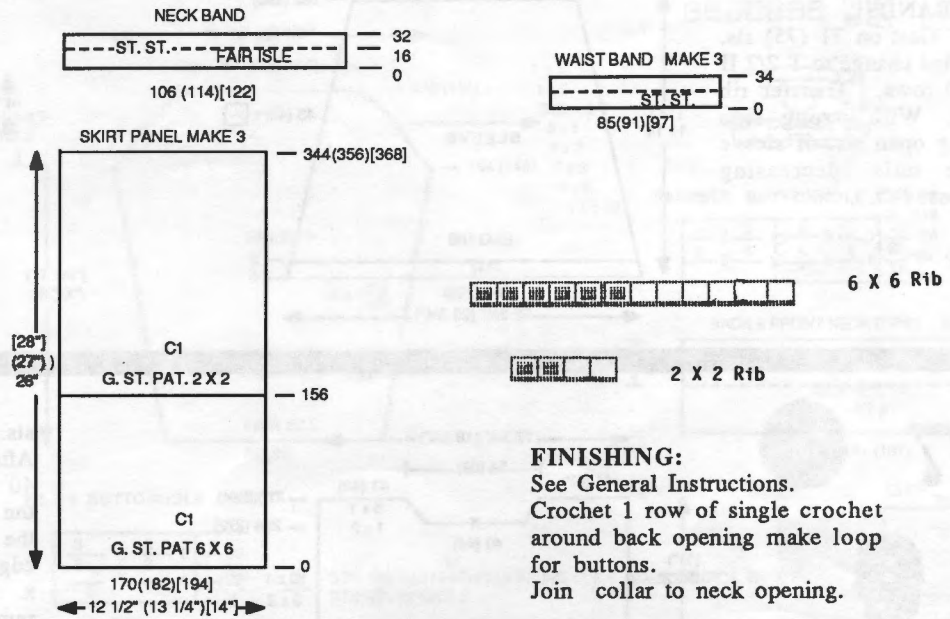

**FINISHING:**  
See General Instructions.  
Crochet 1 row of single crochet  
around back opening make loop  
for buttons.  
Join collar to neck opening.

# 686



## WOMAN'S JACKET

**YARN:** Silkie  
**SIZES:** 8/10 (12/14)  
**AMOUNT:** 26 oz. 28 oz.  
**KIT PRICES:** \$25.00 \$27.00

**TENSION :** English Rib T 2/2  
I, K1/P1 rib T 2/2 II.  
**GAUGE :** Eng. Rib. 16.5 sts.  
31 rows = 2"  
**NOTIONS:** 2 buttons.

Make on any Standard or  
Electronic Machine with Ribber.

**BACK:**  
K1/P1 Rib: Cast on 177 (185)  
Sts. After selvedge knit 2 rows.  
Set carriages for English Rib and  
continue. After R 222 (230)  
mark each side with W.Y. for  
sleeve opening. After R 404  
(420) transfer rib sts. to MB.  
Knit 1 row over all sts. in WP.  
With W.Y. mark for neck  
opening and remove on W.Y.

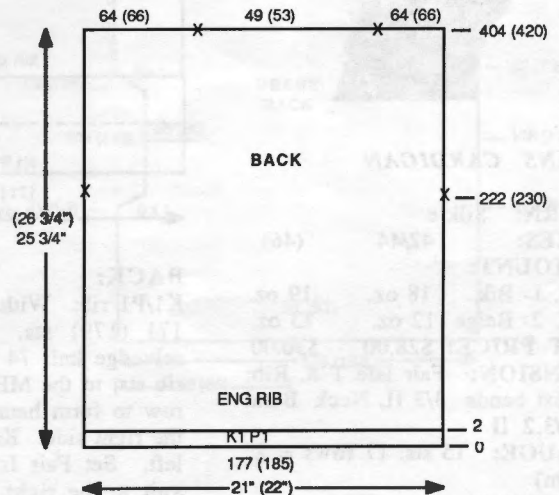

**FRONT:** Make 1, Reverse 1. K1/P1 Rib. Cast on 89 (93) sts. After selvedge, knit 2 rows. Set carriages for Eng. Rib and continue in pattern. After R222 (230), on the right side decrease 1 st. every 7 rows 25 (27) x. After R 404 (420) transfer rib sts. to MB. Knit 1 row over all ndls. in WP and remove on W.Y.

**SLEEVES:**

K1/P1 rib: Cast on 191 (199) sts. After selvedge knit 2 rows. Set carriages for Eng. Rib and continue. ON EACH side decrease 1 st. every 4 rows 43 (45). After row 182 (190) transfer rib sts. to MB. Knit 1 row across all ndls. in WP and remove on W.Y.

**SLEEVE BANDS:**

K1/P1 rib: Cast on 71 (75) sts. After selvedge change to T 2/2 II and knit 50 rows. Transfer rib sts. to MB. With wrong side facing, hang open sts. of sleeve onto these ndls. decreasing evenly across. BO.

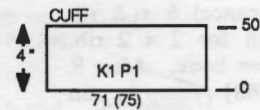
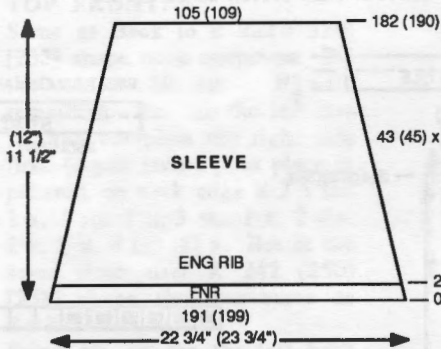
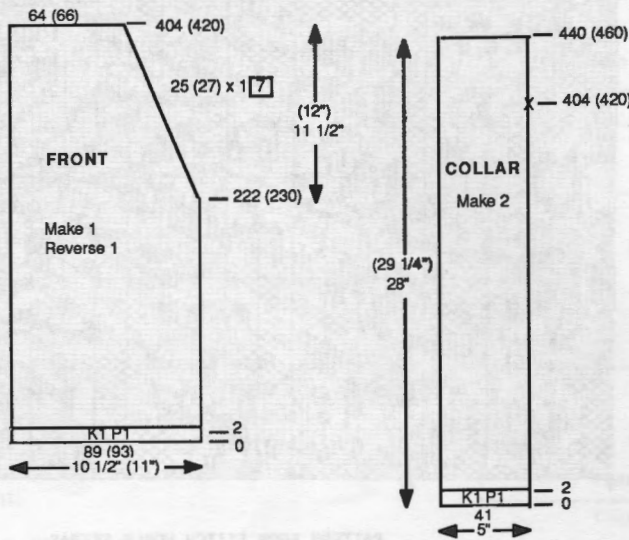

**COLLAR:** Make 2.

K1/P1 rib: Cast on 41 sts. After regular selvedge, knit 2 rows. Set carriages for Eng. Rib and continue. After R 404 (420) mark 1 side with W.Y. (this is where you match it to the shoulder seam.) After R440 (460) transfer rib sts. to MB and BO or remove on W.Y.

**FINISHING:**

See General Instructions. When attaching collar be sure to end with the correct side folded to the front. Attach buttons. (See photo).

**NOTE:** The 49 (53) sts. on the Back Neck line were gathered evenly across to fit into the 72 (80) Rows.

**687**

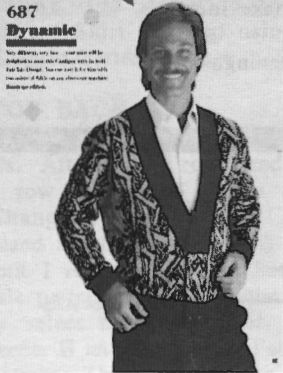

**MANS CARDIGAN**

**YARN:** Silkie  
**SIZES:** 42/44 (46)  
**AMOUNT:**  
 Col. 1- Blk 18 oz. 19 oz.  
 Col. 2- Beige 12 oz. 13 oz.  
**KIT PRICE:** \$28.00 \$30.00  
**TENSION:** Fair Isle T 8, Rib: Waist bands 3/3 II, Neck Band 3.2/3.2 II  
**GAUGE:** 15 sts. 17 rows = 2" (5cm)  
**NOTIONS:** 6 buttons

Make on any Electronic machine with Ribber.

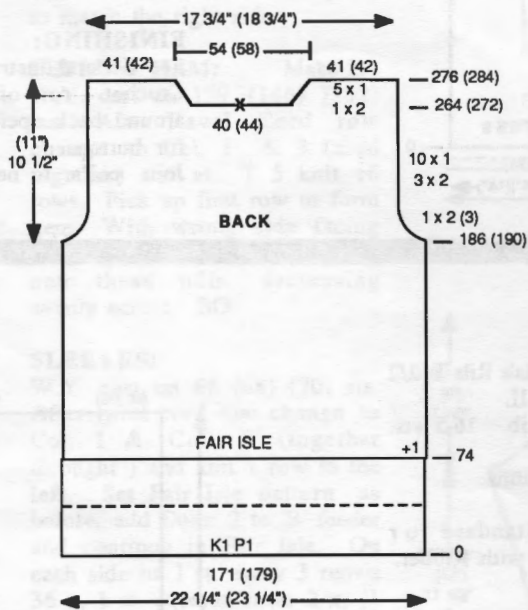

**BACK:**

K1/P1 rib: With Col. 1 cast on 171 (179) sts. After regular selvedge knit 74 rows. Transfer rib sts. to the MB. Pick up first row to the MB. Knit 1 row to the left. Set Fair Isle pattern and knit to the right to select ndls. Add Col. 2 in feeder B and continue in Fair Isle pattern. After R 186 (190), shape armhole. On each side BO 2 (3)

sts. 1 x, 2 sts. 3x, 1 st. 10 x. After R 264 (272) BO the center 40 (44) sts. Place the sts. on the left into HP and complete the right side first. \*On neck edge BO 2 sts. 1 x, 1 st EOR 5 x. After R 276 (284) BO or remove the remaining sts. on W.Y. Bring up on the left back into WP. Turn counter back to R 264 (272) and complete the left half. Follow Instructions from \*.

**FRONT:** Make 1, reverse 1. (One with buttonholes and one without.)

K1/P1 rib: (Buttonhole Front). Starting with ndl. number 13 to the right of -0-, with Col. 1 cast on TO THE LEFT 99 (103) sts. After regular selvedge knit 22 rows. Using your favorite method, make buttonholes (see chart). (If you are using W.Y. remember to knit back the corresponding ribber sts. as well.) Knit to R 50 and repeat the buttonholes. Knit to R 74. Transfer ribber ndls. to MB and pick up first row to form hem. On the right side cast on 27 sts. Knit 1 row to the left. Set Fair Isle pattern and continue same as back. After R 84 make buttonholes (see chart) After R 104 repeat buttonholes. After R

114, on the right side BO 52 sts., then on the right dec. 1 st. every 8 rows 1 x, 1 st. every 6 rows 4 x, 1 st. every 4 rows 4 (6) x, 1 st. EOR 6 x. After R 186 (190) on the left shape sleeve opening. BO 2 (3) sts. 1 x, 2 sts. 3 x, 1 st. 10 x. After R 276 (284) BO or remove on W.Y. the remaining sts. Repeat for other Front but omit the buttonholes and reverse shaping.

**NECK BANDS:** Make 2.  
**CLOSE BOTH SHOULDERS FIRST.**

**K1/P1 rib:** With Col. 1 cast on 181 (187) sts. After selvedge knit 74 rows. Transfer rib sts. to MB. Pick first row to form hem. With wrong side facing and starting at center of back neck opening to first mark at lower front, hang 1/2 onto these ndls. BO. Repeat for 2nd half.

**SLEEVES:**  
W.Y. cast on 84 (90) sts. After several rows end with 1 row ravel cord to the right. Change to Col. 1 and knit 1 row to the left. Set pattern and continue in Fair Isle. On each side inc. 1 st. every 4 rows 20 (21) x, 1 st. every 5 rows 12 x. After R 144 (148) shape sleeve cap. On each side BO 5 (6) sts. 1 x, 5 sts. 1 x, 3 sts. 2 x, 2 sts. 4 x, 1 st. 3 x, 2 sts. 3 (5) x, 3 sts. 1 x, 5 sts. 1 x. After R 176 (184) BO the remaining sts.

**FINISHING:**  
See General Instructions. Finish buttonholes and sew on buttons.

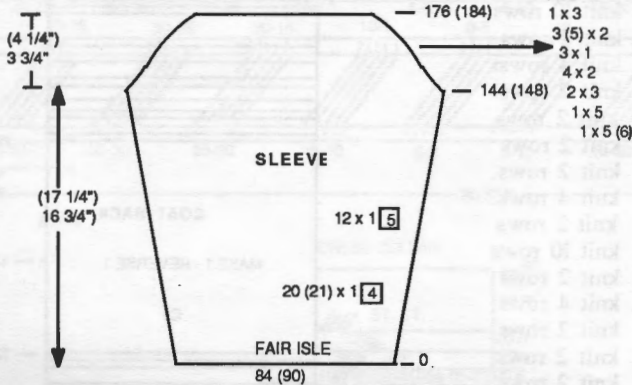
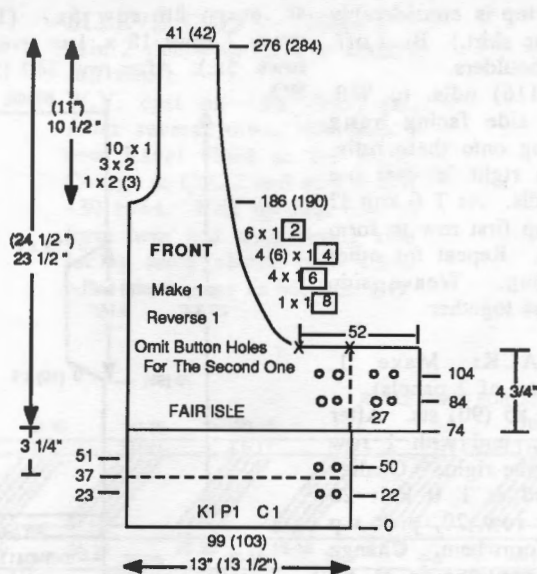

**K1 P1 BUTTONHOLE CHART**

3	5	3	6	74
2	5	2	6	50
3	5	3	6	22
2	5	2	6	0

3/2 STS. ON MAIN BED (COUNTING ONLY NDLS. ON POS. B)  
3/2 STS. ON RIBBER B

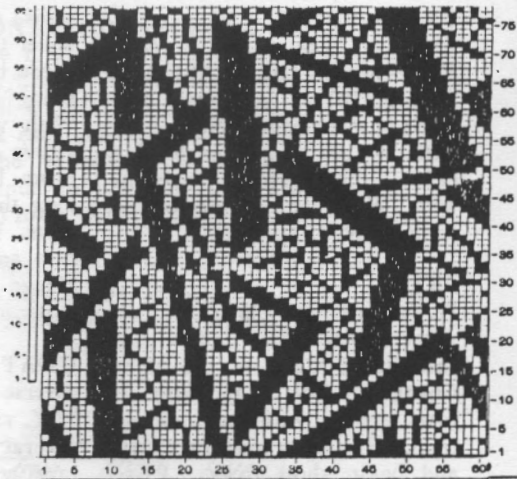

SEND \$1.00 PLUS SASE FOR ENLARGED PATTERN  
60 sts. and 78 rows

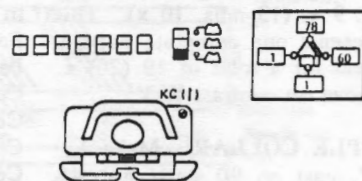

**FAIRISLE BUTTONHOLE CHART**

5	5	5	5	5	5	5	5	5	5	10	114
5	5	5	5	5	5	5	5	5	5	20	104
5	5	5	5	5	5	5	5	5	5	10	84
5	5	5	5	5	5	5	5	5	5	10	74

(5 STS. BUTTONHOLES)

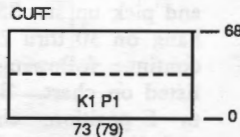
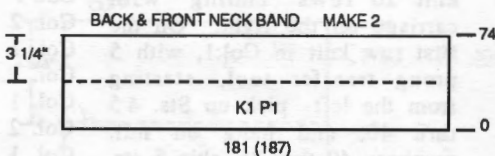

**688**



**KIT PRICE:** \$52.00  
**TENSION:** St. st. - T1,  
Bands T 0, Collar T 0.2 (1)  
**GAUGE:** 23 sts. and 36 rows  
= 2" (5cm)  
**NOTIONS:** 2 buttons (approx.  
1.5 cm) for collar.  
Made on the Simple 7 machine.

**DRESS BACK:**  
W.Y. cast on 126 (132) sts.  
After several rows, end with 1  
row Ravel Cord to the right.  
Change to Col. 1 and knit 1 row.  
Starting at the left side mark St.  
63 (66) with W.Y. (This is for  
sleeve opening). Continue in  
st. st. to R 79 (83). Shape  
neck. Decrease 1 st. EOR 5 x.  
After R 109 (115), on the left  
BO 28 (30) sts. (This is for the  
back neck opening). After R  
129 (135), on neck edge,  
increase 1 St. EOR 5x. After R  
218 (228), mark st. 63 (66) for  
sleeve opening and remove on  
W.Y.

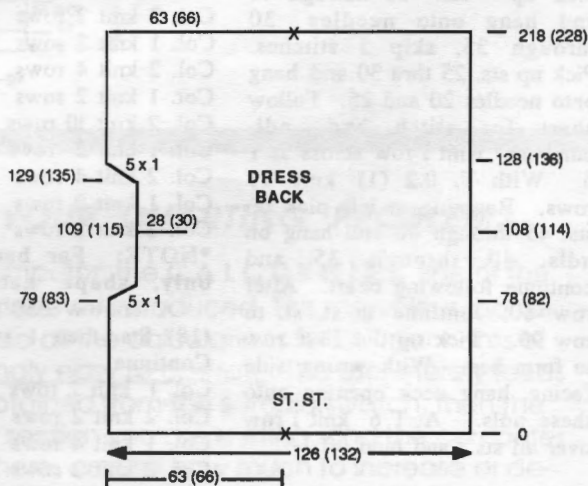

**WOMENS DRESS AND COAT**

**YARN:** Silkie  
**SIZE:** 40/42 (44/46)  
**AMOUNT:**  
Col. 1: Grey: 2-1/2 lbs. all sizes  
Col. 2: Black: 1 lb. all sizes

**DRESS FRONT:**

Same as back to R 79 (83). Shape neck. DECREASE 1 st. EOR 9 (10) x. After row 121 (125) on neck edge increase 1 St. EOR 9 (10) x. After R 218 (228), mark sleeve opening with W.Y. and remove on contrast W.Y.

**SKIRT:**

W.Y. cast on 126 (130) sts. After several rows end with 1 row Ravel Cord to the right. Change to Col. 1 and knit 22 rows ending with carr. on the right. Bring all needles to HP and begin short rows. Push back into WP 14 ndls. 9 x, (13 ndls. 10 x.). Then on opposite side as carr. bring into HP 14 ndls. 9 x, (13 ndls. 10 x.). This represents one complete pattern. Repeat for a total of 19 (20) x. Remove on contrast W.Y.

**RIPPLE COLLAR:** Make 1.

W.Y. cast on 90 sts. (ndl. 45 on the left and 45 on the right. After approx 20 rows of W.Y., change to Col. 1, counter at -0 and at T 6. knit 1 row to the left. Change to T 0.2 (T1) and knit 20 rows ending with carriage on the right. On the first row knit in Col.1, with 5 prong transfer tool, starting from the left pick up Sts. 45 thru 40, and hang on ndl. numbers 40 thru 35, skip 5 sts. and pick up sts. 35 thru 30, and hang on 30 thru 25, skip 5 and continue following st. numbers listed on chart. Bring all ndls. to E position, change to T 6, and knit 1 row to the left. Change to T0.2 (1) and knit 19 rows. Beginning at right side pick up sts. 35 through 40 and hang onto needles 30 through 35, skip 5 stitches. Pick up sts. 25 thru 30 and hang onto needles 20 and 25. Follow chart for stitch and ndl. numbers. Knit 1 row across at T 6. With T. 0.2 (1) knit 19 rows. Beginning at left pick up sts. 45 through 40 and hang on ndls. 40 through 35 and continue following chart. After row 60, continue in st. st. to row 90. Pick up the first row to form hem. With wrong side facing, hang neck opening onto these ndls. At T 6 knit 1 row over all sts. and bind off.

**FINISHING:**

See General Instructions:  
Skirt: Bring 86 (92) sts. to WP. With right side facing, hang 1/2 of Skirt waist onto these ndls. With wrong side facing, hang 1 back or 1 front onto these ndls. (you will have to pleat evenly

across as the top is considerably wider than the skirt.) Bind off. Close both shoulders. Bring 110 (116) ndls. to WP. With wrong side facing hang sleeve opening onto these ndls. From left to right 'e' cast on over these ndls. At T 0 knit 12 rows. Pick up first row to form hem and BO. Repeat for other sleeve opening. Weave side seams of dress together.

**COAT BACK:** Make 1, reverse 1. (total of 2 panels).

W.Y. cast on 85 (90) sts. After several rows, end with 1 row ravel cord to the right. Change to Col. 2 and at T 0 knit 20 rows. After row 20, pick up first row to form hem. Change to T 1 and continue in st. st. Pattern is as follows.

Col. 2 knit 30 rows  
Col. 1 knit 10 rows  
Col. 2 knit 2 rows  
Col. 1 knit 4 rows.  
Col. 2 knit 2 rows.  
Col. 1 knit 2 rows.  
Col. 2 knit 2 rows.  
Col. 1 knit 2 rows.  
Col. 2 knit 4 rows.  
Col. 1 knit 2 rows  
Col. 2 knit 10 rows  
Col. 1 knit 2 rows  
Col. 2 knit 4 rows  
Col. 1 knit 2 rows  
Col. 2 knit 2 rows  
Col. 1 knit 4 rows  
Col. 2 knit 2 rows  
Mark at row 188 (194)  
Col. 1 knit to row 290 (300)  
Col. 2 knit 2 rows  
Col. 1 knit 4 rows  
Col. 2 knit 2 rows  
Col. 1 knit 2 rows  
Col. 2 knit 4 rows  
Col. 1 knit 2 rows  
Col. 2 knit 10 rows  
Col. 1 knit 2 rows  
Col. 2 knit 4 rows  
Col. 1 knit 2 rows  
Col. 2 knit 2 rows  
**\*NOTE: For back sections only, shape neck.**

After row 330 (340) BO 16 (18) Sts. then 1 st. EOR 5 x. Continue.  
Col. 1 knit 2 rows  
Col. 2 knit 2 rows  
Col. 1 knit 4 rows  
Col. 2 knit 2 rows  
After row 340 (350) BO.

**COAT FRONT:** Make 1, reverse 1.

Same stripe sequence as the back and same up to R 188 (194). Begin decrease on neck edge. Dec. 1 st. every 7 rows 16 x, 1

st. every 8th row 5x. (1 st. every 7 rows 18 x, 1 st. every 6 rows 5x.). After row 340 (350) BO.

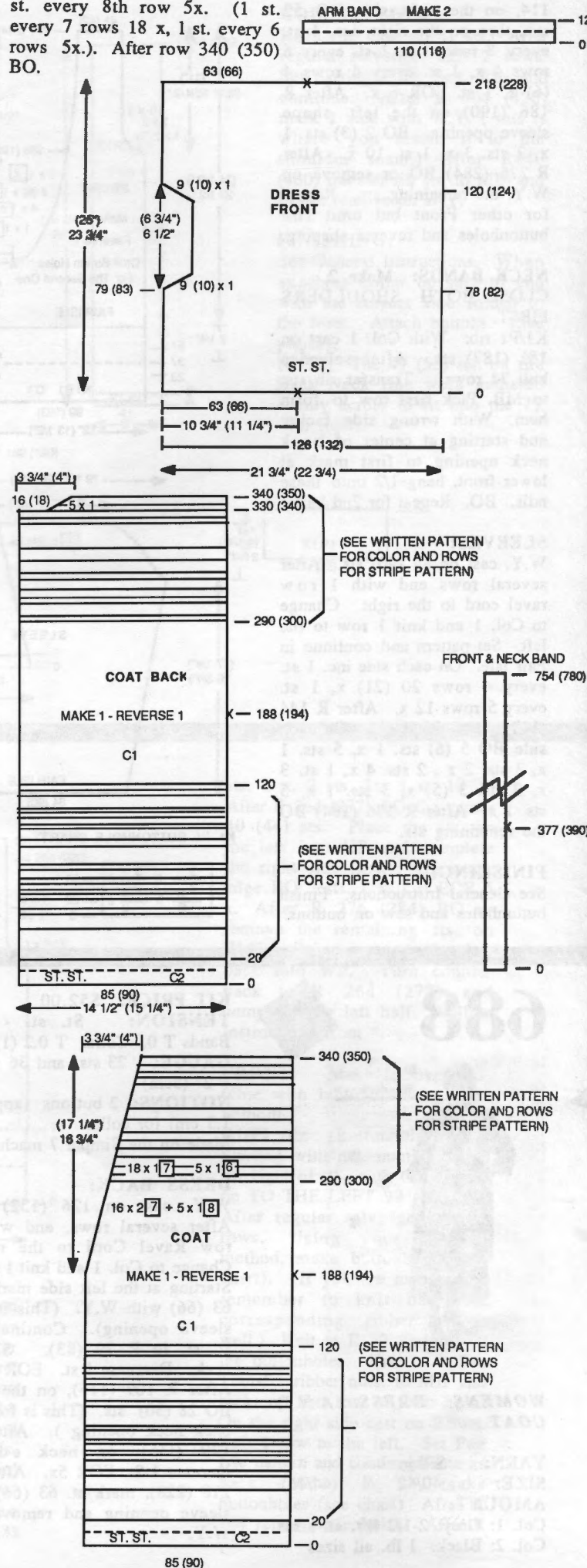

**SLEEVES:** Make 4 (make 2 and reverse 2). Bring to WP 97 (100) ndls. With wrong side facing hang sleeve opening, (From Shoulder to W.Y. marker only. It takes 2 sleeve panels to make 1 whole sleeve.) With Col. 2 continue in st. st. and knit 10 rows. **BUT AT THE SAME TIME** on one side dec. 1 st. EVERY ROW 30 x. then 1 st. every 4 rows 17 (18) x.

Follow the chart for color stripe pattern.

Color stripes are as follows.

Set counter at 10. Change to

Col. 1 knit 36 (40) rows.

Col. 2 knit 2 rows

Col. 1 knit 4 rows

Col. 2 knit 2 rows

Col. 1 knit 2 rows

Col. 2 knit 2 rows

Col. 1 knit 2 rows

Col. 2 knit 4 rows

Col. 1 knit 2 rows.

Col. 2 knit 10 rows

Col. 1 knit 2 rows

Col. 2 knit 4 rows

Col. 1 knit 2 rows

Col. 2 knit 2 rows

Col. 1 knit 2 rows

Col. 2 knit 2 rows

Col. 1 knit 4 rows

Col. 2 knit 2 rows

Col. 1 knit 10 rows

After R 106 (110) remove remaining sts. on W.Y.

**SLEEVE CUFFS:** Make 2.

Join 2 sleeve sections to make 1 full sleeve.

W.Y. cast on 98 (102) sts. After several rows, end with 1 row Ravel Cord to the right. Change to Col. 2 and at T 0 knit 130 rows. Pick up first row to form hem and with wrong side facing hang sleeve onto these ndls. decreasing as needed. BO.

**FRONT AND NECK BAND:**

Make 1.

With Col. 2 'e' cast on 9 sts.

At T 0 knit 377 (390) rows.

Mark each side with W.Y. (this is the center of the back) continue in st. st. to R 754 (780) rows. BO.

**FINISHING:**

See General Instructions.

Sew front band to neck opening.

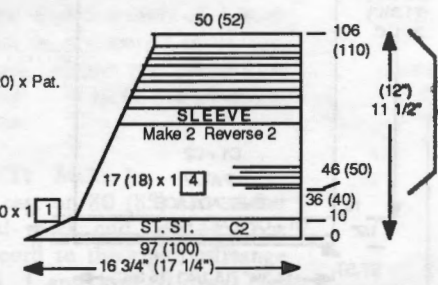
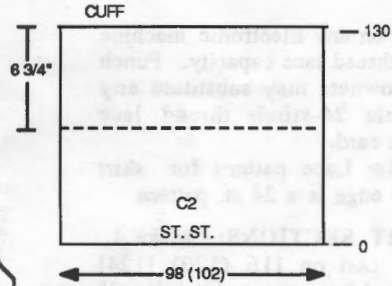
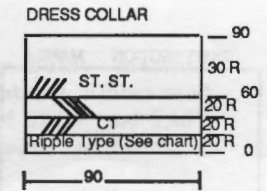
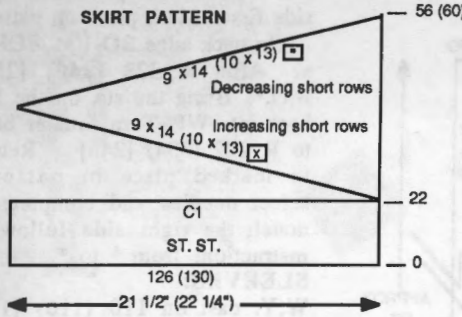
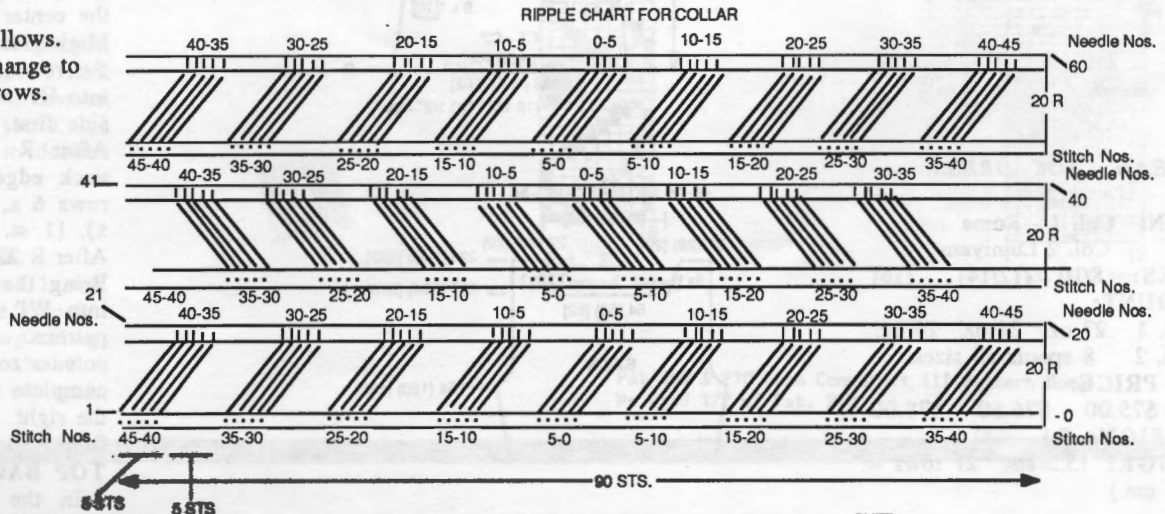

(SEE WRITTEN PATTERN FOR COLOR AND ROWS FOR STRIPE PATTERN)

## THE AMAZING CALCUKNIT SOLVES ALL OF YOUR CHARTING PROBLEMS

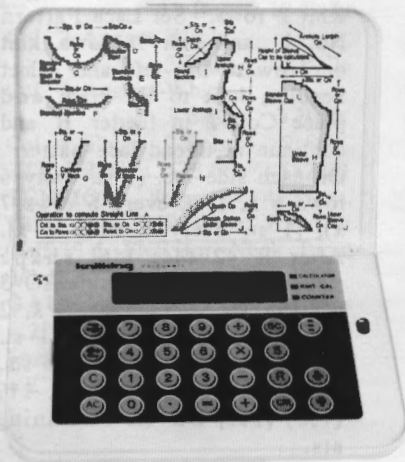

Our new purse-size charting computer, the **CALCUKNIT**, is one of the most popular knitting accessories ever introduced. This marvelous hand-held computer is designed to do all the calculations for knit garments of any size and shape. It is amazingly easy to operate. The user merely feeds in the stitch and row gauge obtained from the sample swatch, then the measurements of the garment section you are knitting, and the computer read out tells exactly when, where, and by how much to increase or decrease. The unique **CALCUKNIT** is self-contained; you will need no other computer.

The price-breaking **CALCUKNIT** has three functional settings: Knit Calculator (described above), Row Counter/Alarm, and Std. Calculator.

Order from your local dealer, or if you do not have one in your area, order direct from **KNITTING**, 1128 Crenshaw Blvd., Los Angeles, CA 90019. Phone: 213-938-2077.

# 689



689  
Feminine

## THREAD LACE DRESS

**YARN:** Col. 1 - Roma  
Col. 2 Lumiyarn  
**SIZES:** 8/10 (12/14) [16]  
**AMOUNT:**  
Col. 1 23 oz. 24 oz. 26 oz.  
Col. 2 8 spools all sizes.  
**KIT PRICE:**  
\$75.00 \$76.50 \$78.00  
**TENSION:** 7.1  
**GAUGE:** 15.5 sts. 21 rows =  
2" (5 cm.)

Make on any Electronic machine with thread lace capacity. Punch card owners may substitute any suitable 24-stitch thread lace punch card.

Regular Lace pattern for skirt lower edge is a 24 st. pattern.

**SKIRT SECTIONS:** Make 4. W.Y. cast on 116 (120) [124] ndls. After approximately 2" end with one row Ravel Cord to the right. Using latch tool and crochet method, with 1 strand Col. 1 and 1 strand Col. 2 together, cast on over these needles from left to right. Knit 2 rows. Set regular lace pattern No. 1 (Comp. III owners use Pat 210 from pattern book). Knit 16 rows, knit one row to the left, then select needles; program Pat. 2 (Thread Lace) to the right and with Col. 2 in feeder B, continue in thread lace pattern. After R 244 (250) [256] remove on W.Y.

**TOP FRONT:** Make 1. Join 2 skirt sections together first. Bring 146 (154) [162] ndls. to WP. With wrong side facing hang open sts. of skirt onto these ndls. decreasing evenly across. With Col. 1 knit 1 row from left to right. Remove yarn from feeder. Press both part buttons in and move carriage to the left. Set Thread Lace pattern. With both part buttons

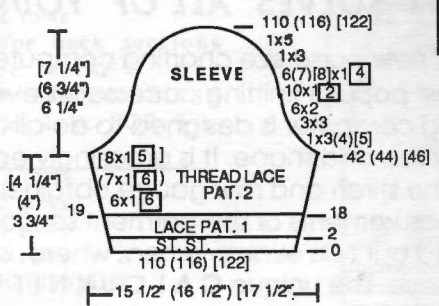
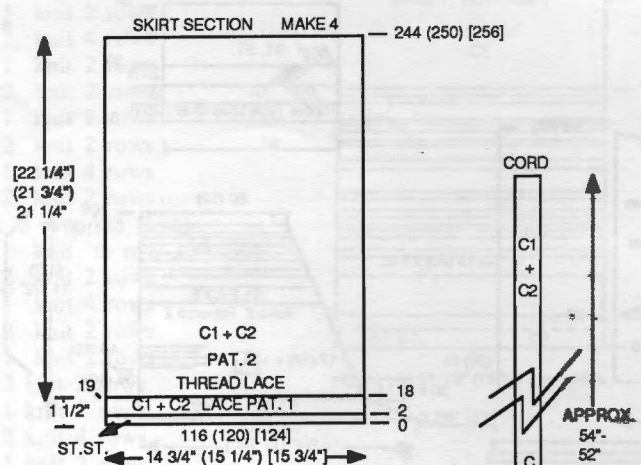
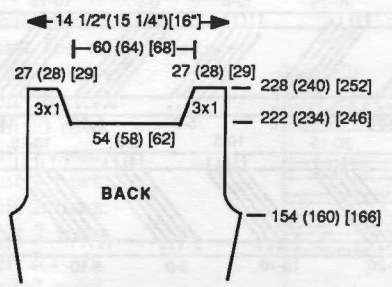
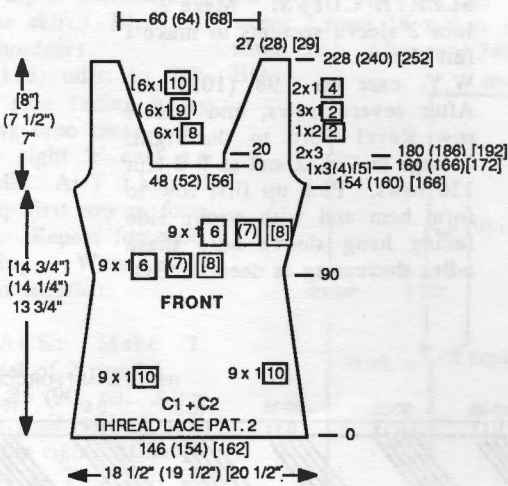

in move the carriage to the right to select ndls. Counter at -0-. With Col. 1 in feeder A and Col. 2 in feeder B continue in thread lace. On each side dec. 1 st. every 10 rows 9 x. Then inc. 1 st. every 6 (7) [8] rows 9 x. After R 154 (160) [166] shape armhole. ON EACH SIDE BO 3 (4) [5] sts. 1 x, 3 sts. 2 x, 2 sts, 1x, 1 st. EOR 3 x, 1 st. every 4 rows 2 x. But at the same time after R 160 (166) [172] shape neck opening. In the center BO 48 (52) [56] sts. Mark place in pattern and place the remaining sts. on the left into HP and complete the right side first. \*Continue in pattern. After R 180 (186) [192], on neck edge dec. 1 st. every 8 rows 6 x, (1 st. every 9 rows 6 x), [1 st. every 10 rows 6x.] After R 228 (240) [252] BO. \* Bring the sts. on the left back into WP. Return to place in pattern. Select ndls. Row counter to 160 (166) [172] and complete the left side to match the right following instructions from \* to \*.

**TOP BACK:** Make 1. Join the remaining 2 skirt panels together. Same as front to R 222 (234) [246]. Shape back neck opening. BO the center 54 (58) [62] sts. Place the remaining sts. on the left into HP and complete the right side first. Mark place on pattern. \*On neck edge BO 1 st. EOR 3 x. After R 228 (240) [252] B.O.\* Bring the sts. on the left back into WP. Turn counter back to R 222 (234) [246]. Return to marked place in pattern, select needles and complete to match the right side following instructions from \* to \*.

**SLEEVES:** W.Y. cast on 110 (116) [122] sts. After several rows end with 1 row Ravel Cord to the right. With 1 strand of Col. 1 and 1 strand Col. 2, using crochet method, from left to right, using latch tool cast on over these ndls. Carr. on the right. Knit 2 rows. Set Lace Pattern No. 1 and knit 16 rows, knit one row to the left and select needles; knit to the right and place Col. 2 in feeder B and continue in thread lace pattern. On each side inc. (1 st. every 6 rows 6 x, 1 st. every 6 rows 7 x), [1 st. every 5 rows 8 x]. After R 42 (44) [46] shape sleeve cap. On each side BO 3 (4) [5] sts. 1 x, 3 sts. 3 x, 2 sts. 6 x, 1 st. EOR 10 x, 1 st. every 4 rows 6 (7) [8] x, 3 sts. 1 x, 5 sts. 1 x. After R 110 (116) [122] BO the remaining sts.

**LACE BAND FOR FRONT NECK OPENING:**

W.Y. cast on 42 (46) [50]. After several rows, end with 1 row Ravel Cord to the right. With 1 strd. Col. 1 and 1 strd. Col. 2 together, using crochet method as before, cast on over these ndls. Knit 2 rows st. st. Set Pat. 1 and knit to R 18. Change to st. st. and knit to R 22. Remove on W.Y.

**CORD FOR HIP TRIM:**

Using Tube knitting technique, (see manual 'cord'), with 1 strd. Col. 1 and 1 strd. Col. 2 cast on 3 stitches and knit (at T 4) approx. 52" (54") or to desired hip size. BO.

**FINISHING:**

See General Instructions. With 1 strd. Col. 1 and 1 strd. Col. 2 together, Single Crochet 1 row around neck opening. Stitch Hip Trim on the line where the skirt and the top meet.

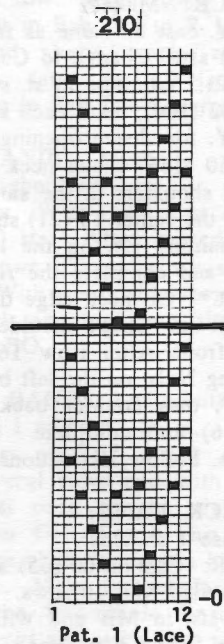
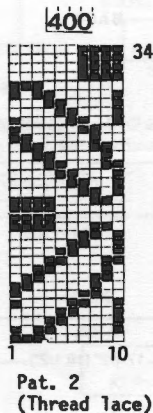
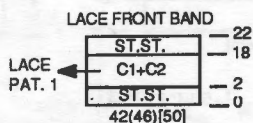

Pat 400 & 210 From Compuknit III Pattern Book  
 We used 1/2 of Pat. 210

**690**



**PANDA SWEATER DRESS**

**YARN:** Amore, Angora & Glace  
**SIZES:** 8/10 (12)  
**AMOUNT:**  
 Col. 1 Amore-White 11 Balls 12 Balls  
 Col. 2 Angora-Black: 5 Balls 5 Balls  
 Col. 3 Angora-White: 3 balls 3 Balls  
 Col. 4 Glace 2 Spls. 2 Spls.  
**KIT PRICE:** \$78.00 \$82.00  
**TENSION:** Intarsia T4, St. st. T3.2., Rib, FNR Waist Band & Cuff 1/1 I, FNR for Neck Band 0/0 II.  
**GAUGE:** St. st.: 9 sts., 14 rows = 2" (5 cm.)  
 Front Intarsia: 9 sts., 15.5 Rows = 2" (5 cm.)

Make on any Bulky machine with Intarsia ability. Ribber used for FNR. Send \$1.00 and SASE for large drawing of Panda, if desired.

**NOTE:** Use 2 strands of Amore together throughout. Angora, use 1 strand. Glace use 4 strands together. Watch for tension changes.

**FRONT:** Make 1 W.Y. cast on 80 (85) sts. After several rows end with 1 row ravel cord to the right. Change to Col. 1 and knit 2 rows. Set machine for Intarsia and continue in design. After R 118 (120), mark each side with W.Y. for sleeve opening. After R162 (168) shape neck opening. BO the center 10 (13) sts. Place the remaining sts. on the left into HP and complete the right side first. \* On neck edge BO 2 sts. 2 x, 1 st. every 4 rows 3 x. But at the same time, after R180 (186) shape shoulder. BO or use short row method 7 sts. 4x. (7 sts. 3x, 8 sts. 1x). Bring sts. on the left back into WP. Turn counter back to 162 (168) and complete left half. Follow instructions from \*.

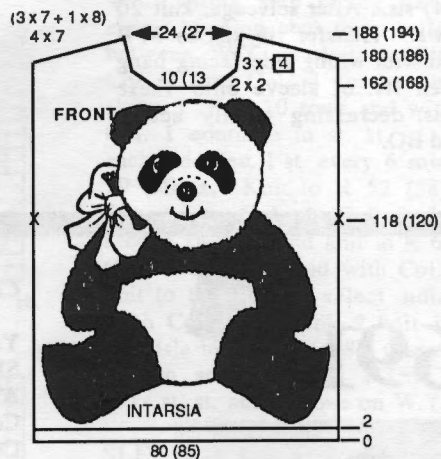

**BACK: Make 1**  
 W.Y. cast on same as front 80 (85) sts. Change to Col. 1 and at T3.2 continue in st. st. After R102 (104), mark each side with W.Y. for sleeve opening. After R160 (166) shape neck opening and shoulders at the same time. BO the center 18 (21) sts. Place remaining sts. on the left into HP and complete the right side first.\* On neck edge dec. 1 st. EOR 3x. Shape shoulders, same as front. After Row 168 (174) bring Ndl. on the left back into WP, turn counter back to 160 (166) and complete the left side. Follow instructions from \*.

**NECK BAND:**

Close 1 shoulder.  
**FNR:** Cast on 60 (65) sts. After selvedge Knit 10 rows. Transfer rib sts. to MB and with wrong side facing hang neck opening onto these ndls. and BO.  
 Close 2nd shoulder.

**SLEEVES:**

Bring 74 (79) ndls. to WP. With wrong side facing hang sleeve opening onto these ndls. Use W.Y. markers as a guide. Bring all ndls. to HP. From left to right, with Col. 1 'e' cast-on over these ndls. and continue in st. st. On each side dec. 1 st. EVERY row 7x, then 1 st. every 7 rows, 10 x. After R80 (84) remove remaining sts. on W.Y.

**SLEEVE CUFFS:**

**FNR:** With Col. 1 cast on 22 (24) sts. After selvedge, knit 20 rows. Transfer rib sts. to MB and with wrong side facing hang open sts. of sleeve onto these ndls. decreasing evenly across and BO.

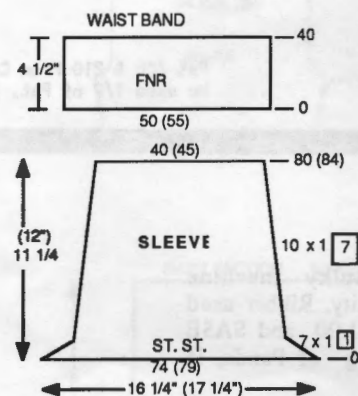
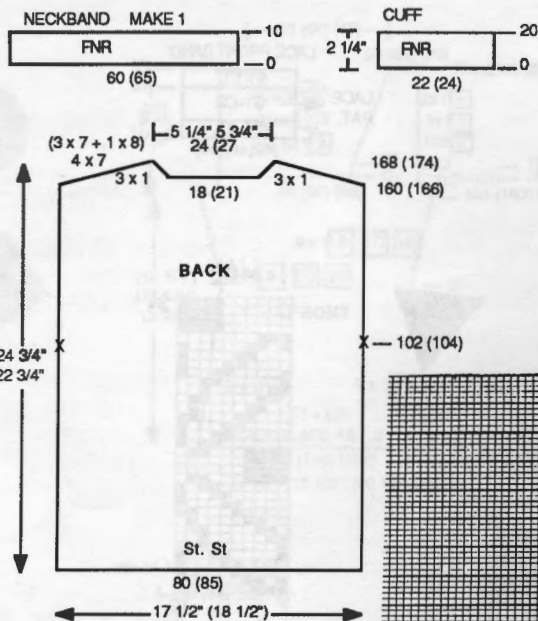

**WAIST BANDS: Make 2**  
**FNR.** With Col. 1 cast on 50 (55) sts. After selvedge knit 40 rows. Transfer rib sts. to MB and with wrong side facing hang open sts. of Front/Back onto these ndls. decreasing evenly across. BO.

**FINISHING:**  
 See General Instructions.

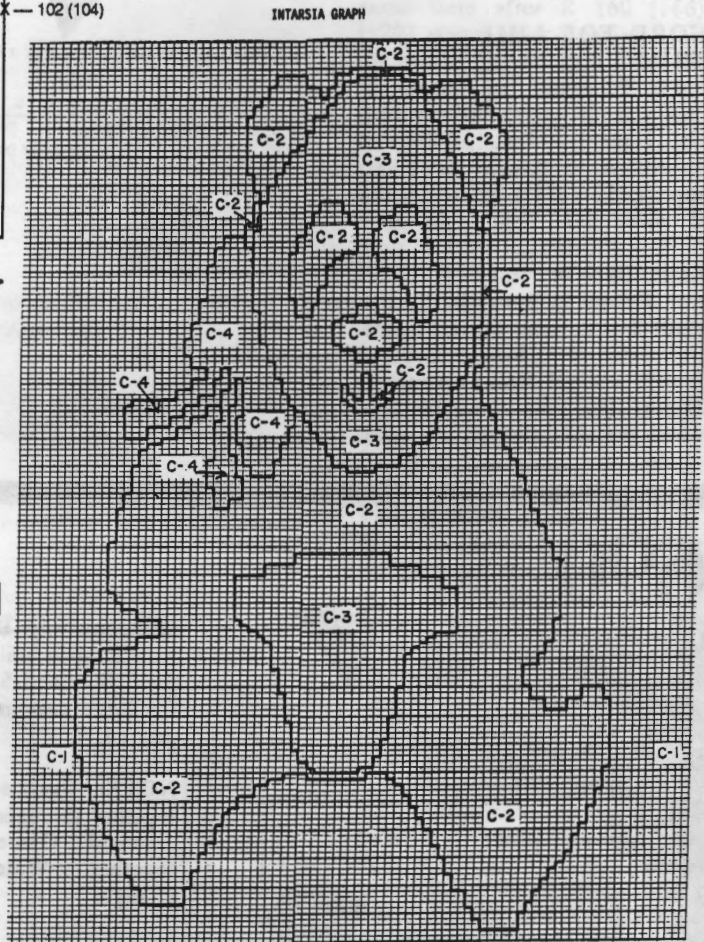

Col. 1 - WHITE ANORE  
 Col. 2 - BLACK ANGORA  
 Col. 3 - WHITE ANGORA  
 Col. 4 - RED GLACE

691

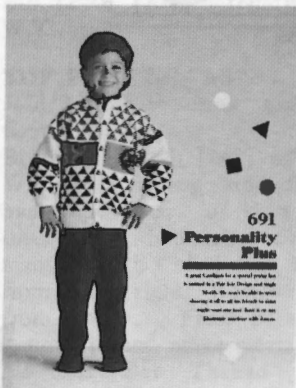

**CHILDS CARDIGAN**

**YARN:** Amore  
**SIZES:** 4/6 (8)  
**AMOUNT:**  
 Col. 1 5 balls 6 balls  
 Col. 2 4 balls 5 balls  
 Col. 3 1 ball 1 ball  
 Col. 4 1 ball 1 ball  
**KIT PRICE:** \$27.00 \$32.00  
**NOTIONS:** 6 buttons  
**TENSION:** St. st. & Fair isle T 6. Ribber T 3.1/3.1 II  
**GAUGE:** 15 sts. 22 rows = 2" (5 cm)

Make on any Electronic machine with Ribber. Punch Card Machine owners may punch card for the 2 diamond patterns, but would have to substitute some

other patterns for the single motifs. Pat. 1 and Pat. 3 have to be input into Compuknit III machine. Pat 2 is #407 in pattern book. Pat. 4 is #87 in pattern book.

**BACK:**

W.Y. cast on 120 (128) sts. After several rows end with 1 row ravel cord to the right. Change to Col. 1 and knit 3 rows ending on the left. Set Pat. 1 and knit to the right to select ndls. With Col. 2 in feeder B, continue in Fair Isle pattern. After R 64, with Col. 1 only continue in st. st. After R 88 (94) mark each side with W.Y. for sleeve opening. After R 107



(115) set Pat. 2. (Comp III owners use Pat. 407 from book.) knit to the right to select ndls. and with Col. 1 & Col. 2 continue in Fair Isle pattern. After R 166 (176) shape back neck. BO the center 30 (34) sts. Mark place in pattern. Place remaining sts. on the left in HP and complete the right side first. \*SHAPE NECK AND SHOULDER AT THE SAME TIME. On neck edge dec. 1 st. EOR 3 x. On shoulder BO or use short row method, 14 sts. 3 x, (14 sts. 1x, 15 sts. 2 x ).

Bring ndls. on the left back into WP. Turn counter back to R166 (176). Return to correct line of pattern, select ndls. and complete the right side. Follow Instructions from \*.

**BACK WAIST BAND:**

Make 1. K1/P1 rib: with Col. 1, cast on 111 (119) sts. After regular selvedge knit 34 rows. Transfer rib sts. to the MB and with wrong side facing, hang back onto these ndls. decreasing evenly across. BO.

**LEFT FRONT:** Make 1. To the left of 0, W.Y. cast on 60 (64) sts. same as Back. Change to Col. 1 and knit 4 rows setting Pat.1 on the 4th row. With Col. 1 & Col. 2 continue in Fair Isle pattern. After R 64 cancel pattern and with Col. 1 only, knit 2 (6) rows. Change to Col. 4 and knit 1 row to the left. Set Pat. 4, SINGLE MOTIF and start on Yellow 45. Knit to the right to select the ndls. Add Col. 3 to feeder B and continue in Single Motif Fair Isle pattern. But at the same time after R 88 (94) on left side mark for sleeve opening. After R 106 (110) change to Col. 1 and knit 2 (6) rows st. st. setting Pat. 2 on the last row. With Col. 1 & Col. 2 knit to R 148 (156). On the right side, shape neck. BO 5 (7) sts. 1 x, 3 sts. 1 x, and 1 st. EOR 10 x. BUT AT THE SAME TIME after R 166 (176) shape shoulders same as Back.

**RIGHT FRONT:** Make 1. To the right of 0, W.Y. cast on 60 (64) sts. as before. Knit to row 64. Cancel pattern. With Col. 1 knit 2 (6) rows st. st. Change to Col. 3 and knit 1 row to the left. Set Pat. 3. Comp III owners use Sel. 2 for single motif. Program 2 motifs. Green 10 (12). Variation keys 3 and 4. Knit 1 row to the right to select ndls. Add Col. 4 in feeder B and knit single motif. After R106 (110) cancel pattern and with Col. 1 knit 2 (6) R setting Pat.

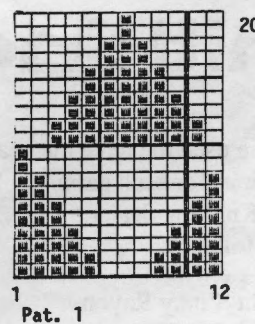
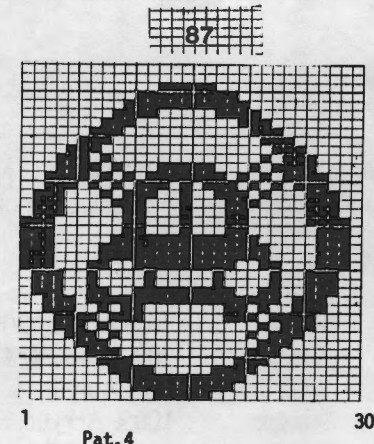
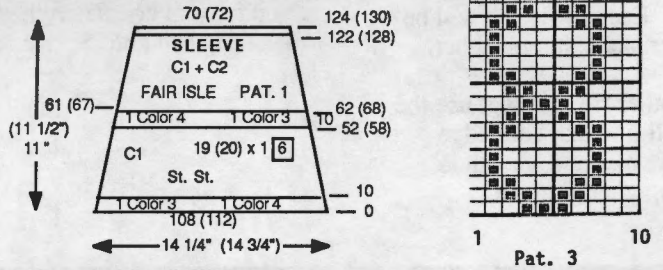
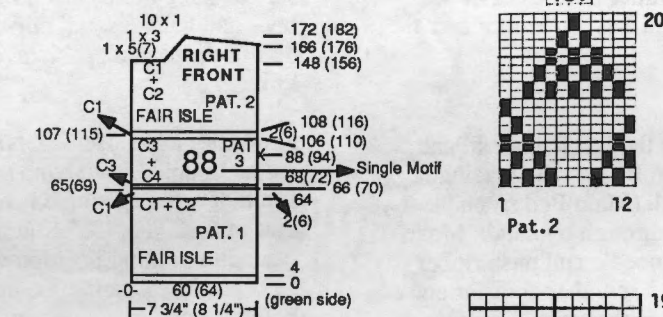
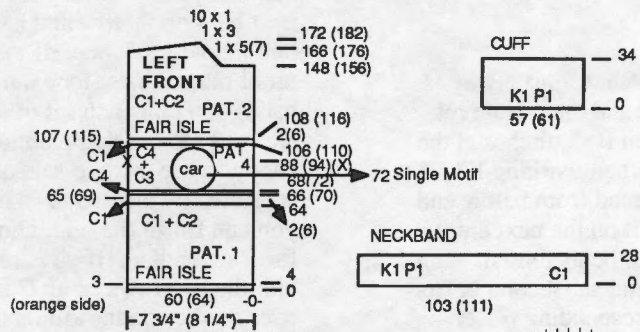
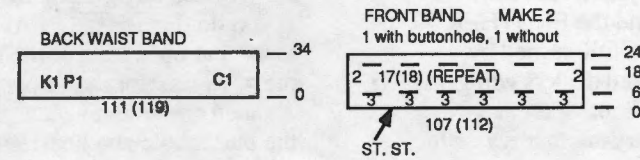
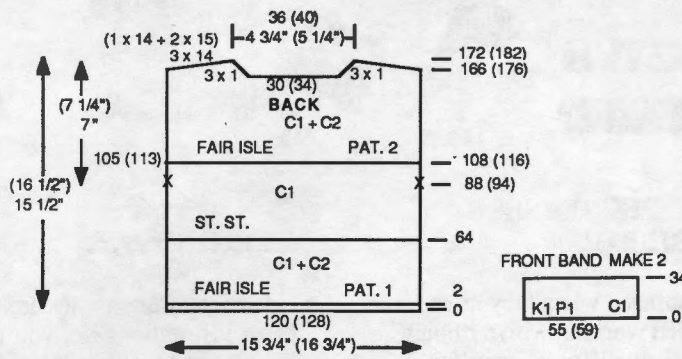

2 on last row. After row 108 (116) knit in Fair Isle to R 148 (156) and shape neck and shoulders same as left front continuing in Fair Isle pattern.

**NECK BAND:** Make 1.

Join both shoulders first. K1/P1 rib: With Col.1 cast on 103 (111) sts. After selvedge knit 28 rows. Transfer rib sts. to MB. With wrong side facing, hang neck opening onto these ndls. and BO.

**FRONT BANDS:** 1 with button holes and 1 without. St. st.

W.Y. cast on 107 (112) sts. After several rows end with 1 row ravel cord to the right. Change to Col. 1 and knit 6 rows. See chart for button hole placement. Make buttonholes if this is the buttonhole band. Knit 12 rows and make 2nd. row of buttonholes. After R 24, pick up first row to form hem and with wrong side facing hang front opening onto these ndls. (be sure to include the neck band.) and bind off.

**FRONT WAIST BANDS:** Make 2.

K1/P1 rib: With Col. 1 cast on 55 (59) sts. After selvedge knit 34 rows. Transfer rib sts. to MB and with wrong side facing hang front onto these ndls. and BO.

**SLEEVES:**

Bring 108 (112) ndls. to WP. With wrong side facing hang sleeve opening onto these ndls., between W.Y. markers. With Col. 3 (use Col. 4 for second sleeve.) Knit 10 rows and with Col. 1 continue in st. st. On each side dec. 1 st. every 6 rows 19 (20) x. Knit to R 52 (58). Change to Col. 4 (Col. 3 for second sleeve ) and knit to R 61 (67). Set Pat. 1 and with Col.1 knit to the right to select ndls. With Col. 1 and Col. 2 knit in Fair Isle to R 122 (128). Cancel pattern and with Col. 1 knit 2 rows st. st. and remove on W.Y.

**SLEEVE CUFFS:**

K1/P1 rib: With Col. 1 cast on 57 (61) sts. After selvedge change to T 3.1/3.1 I and knit 34 rows. Transfer rib sts. to MB. With wrong side facing hang sleeve edge onto these ndls. and BO.

**FINISHING:** See General instructions.

## INCREASES AND DECREASES WHEN USING A RIBBER

Knitters can become confused when they must increase or decrease when working with a ribbing attachment. There are many different ways for increasing and decreasing and the **BROTHER RIBBER TECHNIQUES BOOK** carried by **KNITKING** and its authorized dealers will give you examples that are excellent. However, perhaps you would like to try another way which might be easier for you.

### TO INCREASE:

As you must know, end stitches most always are a knitter (Main Bed ) stitch and there is no rule that you cannot have 2 Main Bed stitches at the ends - so to increase 1 st. when working K1,P1 Ribbing, pick up a cross thread from below end st. on Main Bed and place it on the next empty knitter needle, on the side to be increased. Knit 1 row, then transfer the 2nd end st. (second in from the outside edge) to the corresponding ribber needle and push empty knitter needle out of work. You have increased 1 st. on knitter and 1 st. on Ribber.

### TO DECREASE:

To decrease 1 st. pick up the last Ribber st. and place it onto the end Main Bed needle placing it in front of the needle latch (Main Bed stitch behind latch) and knit it through by hand. Move this stitch over to empty needle and push ribber needle out of work, knit 1 row then transfer end st. to knitter needle, knit it through. Continue ribbing to next decrease. Each time, you will be decreasing 1 st. on knitter and 1 st. on Ribber.

For double knitting, or other rib knitting, use the same method and you will find that your edge increases and decreases are nice and smooth to make it easier for seaming your garment.

## BUTTONHOLES

Horizontal buttonholes are not difficult to make. Most instructions tell you to knit the buttonhole sts. by hand using a contrast yarn or ravel cord. If you do this for only 1 row, it can be difficult to see the open sts. for the top of buttonhole and the open sts. for the lower edge of buttonhole. A much easier and neater way as well, is to knit the buttonhole stitches **TWICE** using the contrast yarn or cord. Continue knitting to the next buttonhole row and again knit the buttonhole sts. twice. If there must be a double set of buttonholes (for example a doubled front band) you knit each set of stitches. When you are ready to finish the buttonholes, you will be happy to see the two sets of sts. actually separated by the two rows of hand knitting and you can finish the buttonholes using your favorite method. If you are using the Ribber, knit the two rows (with Contrast or Ravel Cord) over needles on the knitter and the ribber then be sure to bring these ends down between the needle beds and hang a small clip onto the ends so they do not cause you problems as you continue to knit.

For **VERTICAL BUTTONHOLES** whether they are on doubled front band that is in stockinette stitch or a ribbed single layer band, you must knit in **SECTIONS**. Stitches on the left are placed in holding position while you knit the right sections, then these needles are placed into holding position while you knit the left section. You must of course set the Carriage controls correctly and knit the one section at a time.

---

## *yarns by* **knitking**

The finest quality **KNITKING** yarns are used to create the beautiful fashions found in **KNITKING** Magazine. Kit prices are located with the instructions for each garment. Each yarn comes in a wide selection of colors. Color cards are available through **KNITKING** or an authorized Knitking dealer.

Content of the yarns used in this issue follows:

Glace	100% Bright Slinky Rayon	Roma	80% Acrilan/20% Antron
Angora	100% French Angora Rabbit	Venetia	70% Wool/30% Rayon
Pearlyte	100% Rayon Boucle	Acrylite	2/12 Acrylic
Silkie	100% 2-Ply Orlon	Amore	100% Acrylic
Bulkytime	100% Bulky Orlon	Starlite	100% Acrylic with Metallic Thread



## 683 **Safari**

Out of Africa, the jungle print of a Skirt inspired the design for this Pullover. A single Giraffe Motif is on the front, the sleeves pick up jungle spots and stripes to tie it all together. Knit it on any Electronic with Kotton.

# 684 Shape of Things to Come

Slim line, surplice front closure and fitted sleeves are back in our fashion world. A narrow belt encircles the waist of this pretty dress that is knitted in stockinette stitch on any standard machine. The yarn is Venetia.





# 685 **Incomparable**

A two piece Dress has a bold Fair Isle Design (taken from Stitch World Extra's) on the flattering Blouse. The Skirt is permanently pleated and is made using the Garter Carriage. Knit it with two colors of lovely Venetia.

686

## Perfect Topper

to wear everywhere. The classy Jacket in

English Rib is a great traveling companion and can be worn over casual or dressy clothing. The front bands fold

over and continue around the neck, forming the collar. Buttons decorate the lower edge of front band. Knit this one

on any standard or electronic machine with ribbing attachment using our

Silkie yarn. Sleeve bands are

K1, P1 Ribbing.

Sizes 8 to 14.



687

# Dynamic

Very different, very new. . . your man will be delighted to wear this Cardigan with its bold Fair Isle Design. You can knit it for him with two colors of Silkie on any electronic machine. Bands are ribbed.





690  
**Beary Nice**

Panda is an Intarsia Design down the front of a child's Dress. It's knitted on a bulky machine with Intarsia technique. Cuddly and warm, the yarn is a combination of our Amore, Angora and Glace. Full needle ribbing makes the bands. Sizes 8 to 12.





689

## **Feminine**

Thread Lace knitted with Roma and Lumiyarn makes up into a very young and most flattering dress. This lovely garment is highlighted with a second color. It's perfect for a party as well as a Spring Fling.

688

## Simple Seven

knits a complete ensemble to flatter a full figure. The Skirt section of dress is knitted sideways using short rows. Stripes are used for accent on the three quarter length sleeves, lower edge and shoulders of a lovely Coat.

Knit it with Silkie for perfect results.



*"I go with my Simple Seven . . .*

*It helps keep me  
looking and  
feeling  
good . . . "*



# Simple Seven by **knitking**

THE IDEAL KNITTING MACHINE FOR BEGINNERS . . .

Complete with well-illustrated, easy-to-follow, 60 page Instruction Manual. One hour V.H.S. video tape of lessons including step-by-step instructions for knitting three sweaters . . . The shipping carton doubles as a carrying case.

HOW TO USE  
YOUR MACHINE



HOW TO USE  
YOUR MACHINE



Has Twin Yarn Feeders for two color designs . . . The tool kit includes special Cable Tools, Needle Pushers for fancy stitch selection, Row Counter for accurate row count, Silicone oil for lubrication, etc. etc.



Home knitting machines generally come in two classifications: Standard—for knitting yarns from single ply to sport weight—Bulky for knitting yarns from sport weight to bulky . . . Standard machines have a space between needles of 4.5 millimeters. Bulky machines have a space of 9.00 millimeters . . . In order to knit a range of yarns from dress weight to bulky it was always necessary to own two machines. Simple Seven has a needle space of 7.00 millimeters and it knits dress yarns and bulky yarns with equal ease.

Simple Seven has 132 needles. If you knit four ply worsted at four stitches per inch, you can knit up to 33 inches wide . . . In addition to knitting clothes you can knit afghans, throw rugs, bed spreads, table clothes, etc . . . The instruction manual teaches you how to knit Skip Stitch Patterns, Lace Patterns, Tuck Stitch Patterns (popcorn stitch, etc), Knit and Purl Stitch Patterns, Cable Stitch Patterns and much much more . . . Simple Seven has great versatility for its low low price.

Order from your local Knitking dealer, or if you do not have one in your area, direct from KNITKING. Phone 213-938-2077. VISA, MasterCard and American Express are accepted.



KNITKING 1128 Crenshaw Boulevard, Los Angeles, California 90019



691

▶ **Personality  
Plus**

---

A great Cardigan for a special young boy is knitted in a Fair Isle Design and single Motifs. He won't be able to resist showing it off to all his friends (a sister might want one too). Knit it on any Electronic machine with Amore.

# WAY TO GO . . .

# knitking

Are you satisfied with nothing but the finest, most versatile and yet easy to use home knitting machine equipment? Then read on and be amazed . . .



*"I bet you never saw a computer that looked like me before!! The folks at KNITKING call me KC III . . . You can call me "Casey". I have an affinity for (truth is I'm crazy about them) color Television sets, Disk Drives and Compuknit III knitting machines . . . Put us all together, manipulate our controls and I promise oodles of creative fun that will make you and your family the best dressed people on your block . . .*

*Hook me up (one plug only) to your color T.V. set and I will project a grid onto its screen. Also projected will be one cursor, the size of one rectangle in the grid . . . With the controls on my right-side you can move that cursor anywhere you wish*

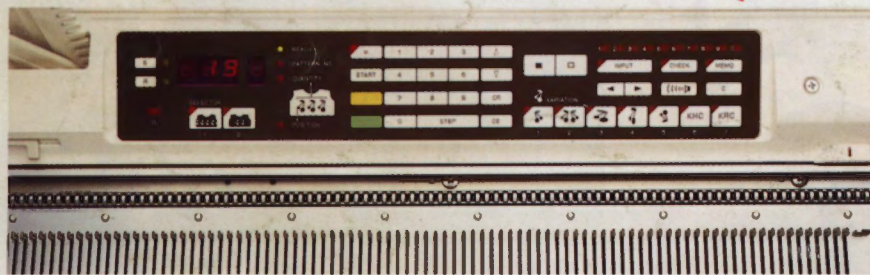

*The Compuknit III has the capacity to store designs with a total number of 13,600 stitches . . . The total can be made up with a number of small designs or one very large one . . . I just know however that our creative juices will not allow us to stay there, even though it is possible to remove and replace any one design at random . . . Once we have created something together we will not want to let it go . . . and that is where my friend the Disk Drive comes in . . . Plug me into a Knitking Disk Drive and all of our design masterpieces can be transferred to a Disk for recall*

*to create any design your clever heart desires . . . My cursor moves accurately from rectangle to rectangle (each one represents a stitch) filling them in or leaving them blank at your command . . . When you have your design completed you can fill in the colors of your choice (with the controls on my left side). Any errors you make as you go along can easily be corrected . . . The 555 designs programmed into the Compuknit III knitter are also a part of my repertoire . . . You can project any one (or several) on to your T.V. screen and alter its form, remove or add parts, isolate sections, join several designs together and generally create unique designs that will please you and astound your friends.*

*I have an outlet that connects directly with a Compuknit III knitter . . . Hook me up and you can go ahead and knit your masterpiece, just as you viewed it on your T.V. screen . . . Now isn't that something?*



*at any time into the Compuknit III . . . Every design has its own number and you recall it just by pushing that number on your Compuknit III . . . Every Disk has 40 tracks and each track accomodates 13,600 stitches . . . One Disk actually has 40 times the capacity of the Compuknit III . . . and you can build a library of Disks.*

*And that's not all!! I have another friend with whom I am compatible (a special hook up cable is needed). Connect me to a Dot Matrix printer and we will print out actual designs created by you on your T.V. screen. This will give you ready pictorial reference to all the beautiful patterns we dreamed up and stored on Disks . . . Exciting?"*

*"If you would like a hands-on demonstration, or have any questions, get in touch with your local Knitking dealer or, if you do not have one in your area, call KNITKING at 213-938-2077 and ask for 'Casey'. I am at your service . . . KNITKING and its dealers will also tell you my current special price and that of my friends . . . Mastercard, Visa and American Express are accepted."*