

KNITTING MANUAL

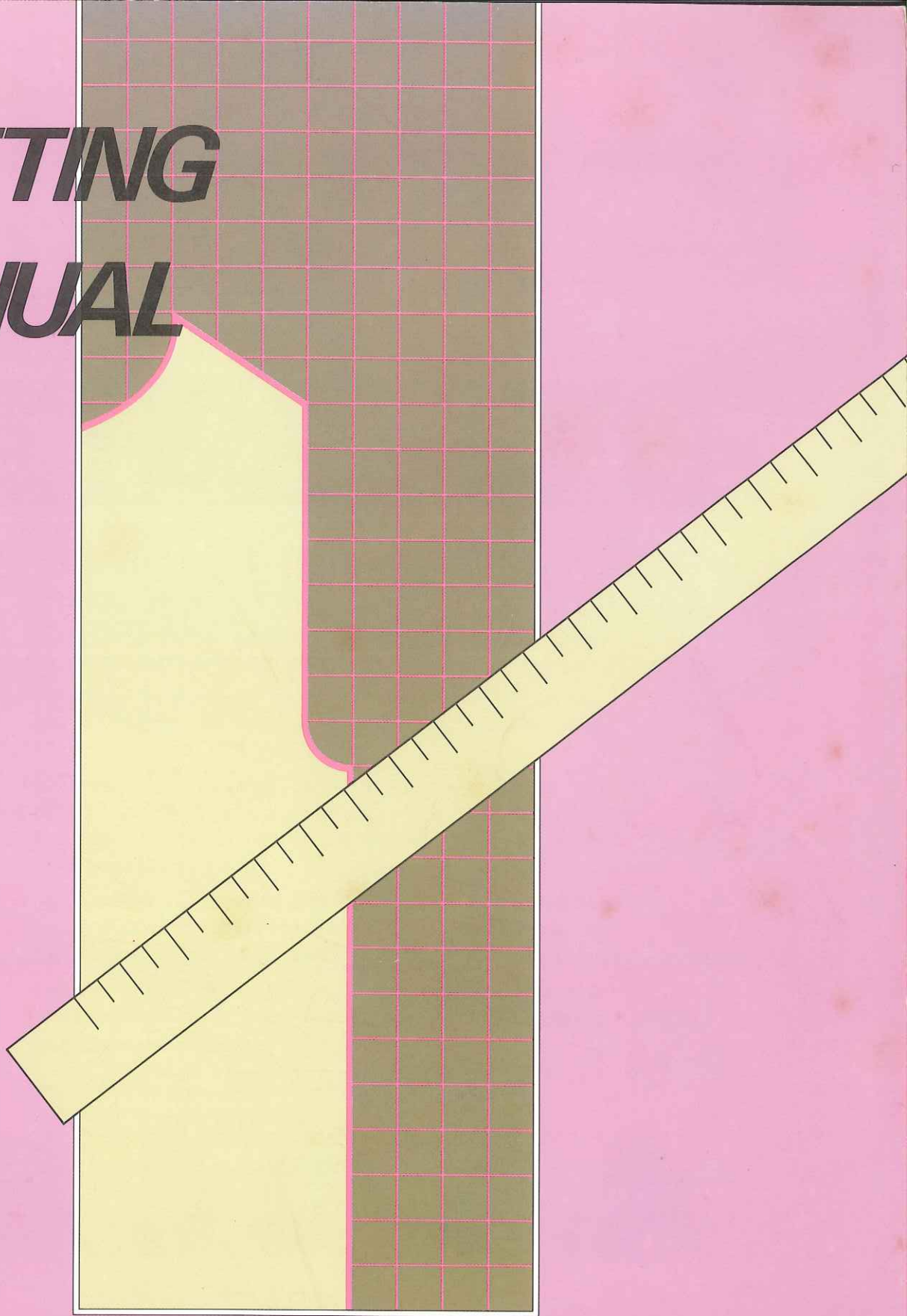

MODEL F-370/270

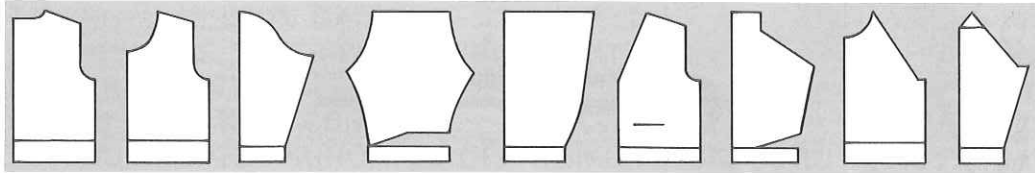

To get to know garment knitting...

With easy-to-follow method, this manual helps you obtain comprehensive knowledge of garment knitting.

Knitting procedure with the use of the built-in Knit Contour, and a collection of necessary knitting techniques are given for your frequent reference.

Keep this manual beside you while you are sitting in front of the machine so as to expand your scope of knitting. And the preprinted pattern styles will also enable you to satisfy your creativity in knitting.

This manual opens with TAKING A TENSION GAUGE, as it is the first and most important step, which should not be overlooked, to make your garment correctly to desired size.

For the owners of the knitting machine without the Knit Contour, separate Knit Contour attachment is available for an optional purchase.



...till a garment is completed.

1

Set up the machine



Refer to the Operation Manual.

2

Knit a tension swatch



The Gauge Scale helps you take a correct tension gauge.

3

Set the Knit Contour



Row number
Pattern Paper
Stitch Scale

4

Knit pieces



5

Block out and press



6

Make up the garment



CONTENTS

	page
TAKING A TENSION GAUGE	1
IF A MISTAKE TAKES PLACE WHILE KNITTING.....	4
PATTERN PAPER	5
SETTING THE KNIT CONTOUR	7
TO UNDERSTAND PRINCIPLES OF THE KNIT CONTOUR	11
KNITTING ON THE KNIT CONTOUR	13
KNITTING WITHOUT USING THE KNIT CONTOUR	19
KNITTING TECHNIQUES.....	23
Fully fashioned decrease/increase	23
Partial knitting by decreasing stitches.....	24
Partial knitting by increasing stitches	26
Holding stitches.....	28
Cast off	30
Mock rib	31
Hemming	32
Trimming.....	33
Buttonhole.....	34
Joining.....	35
K1. P1. rib	36
Cable stitch	37
Garter stitch.....	37
Cord knitting.....	38
Pompon	38
KNITTING GUIDE.....	39
A-2 Lady's Cardigan	39
A-3 Lady's Raglan Sleeve Pullover	40
A-4 Lady's Skirt	41
A-5 Lady's Slacks	42
A-6 Lady's One-piece Dress.....	43
B-2 Man's Cardigan.....	44
B-3 Man's Raglan Sleeve Pullover	40
C-1 Child's Pullover	46
C-2 Child's Cardigan.....	39
C-3 Child's Raglan Sleeve Pullover	47
C-4 Child's Slacks.....	42
C-5 Child's Skirt.....	48
C-6 Child's Top.....	48
C-7 Child's Coat	50
C-8 Child's Brief.....	51
C-9 Leggings.....	52
C-10 Rompers	53
INDEX.....	55

TAKING A TENSION GAUGE

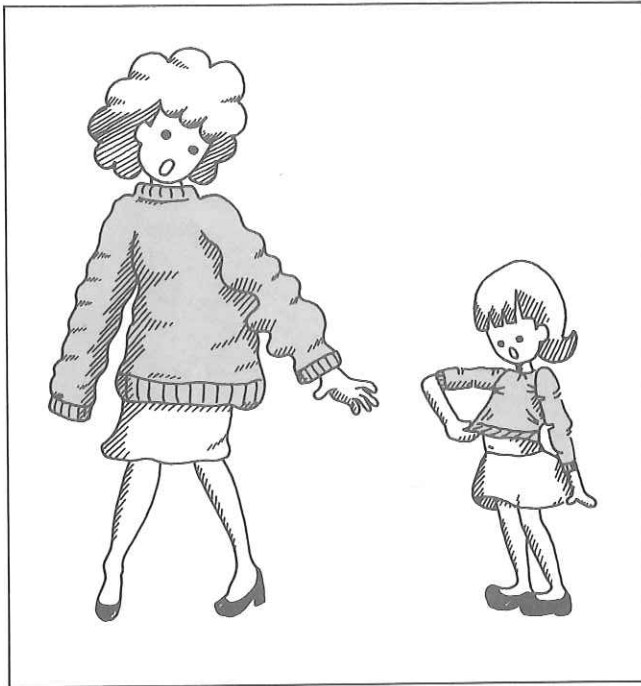

Tension Gauge

Your success in knitting greatly depends on taking a correct tension gauge, because knitted fabrics are affected by type of yarn and stitch. If this most important step is overlooked or ignored, you will never be able to knit your garment to the correct size.

Tension swatch

Tension swatch is a practical method to determine correct tension gauge for the yarn and stitch type you selected for knitting a garment.

With the yarn you selected, knit the tension swatch in the predetermined manner as described below.

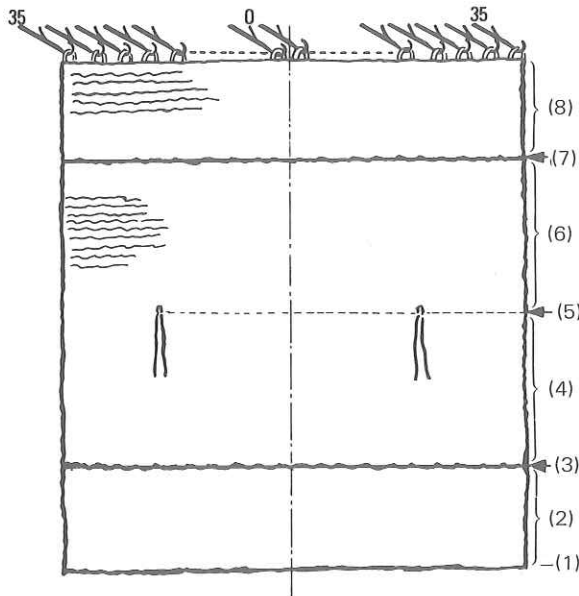

To knit a tension swatch

Before knitting the tension swatch, try knitting till you obtain suitable Stitch Dial number for the selected yarn.

Then knit the swatch in the manner instructed below.

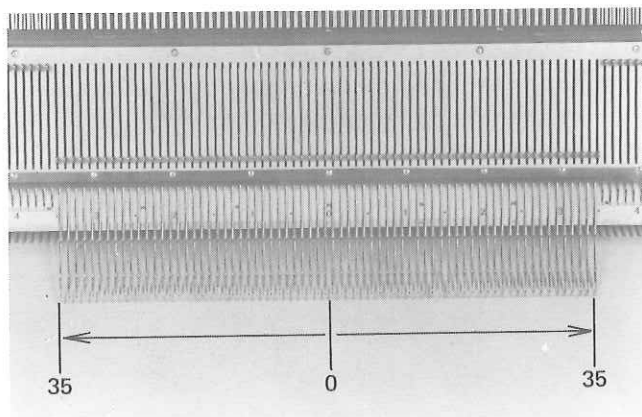

- (1) Push up 35 needles on both sides of "0" on Needle bed and cast on.
Knit several rows in stockinet continuously.

(2) In the selected stitch type, knit 20 rows.

(3) With a contrast yarn, knit 2 rows in stockinet.

(4) In the selected stitch type, knit 30 rows.

(5) Push both 21st needles from centre(0) to D position.
With a piece of contrast yarn, knit them back to B position by hand.

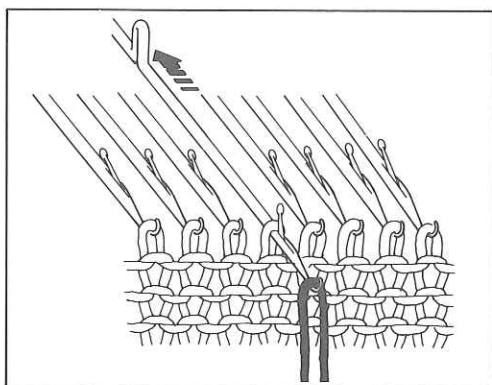

(6) Knit another 30 rows.

(7) With a contrast yarn, knit 2 rows in stockinet.

(8) Knit another 20 rows.

TAKE NOTE OF THE STITCH DIAL NUMBER BEFORE REMOVING THE TENSION SWATCH FROM THE MACHINE.

(9) Remove the swatch from the machine and leave it for several hours to relax.

(10) Press the swatch lightly with a steam iron, or with an ordinary iron over a damp cloth.

To take a tension gauge, follow the instruction on page 3.

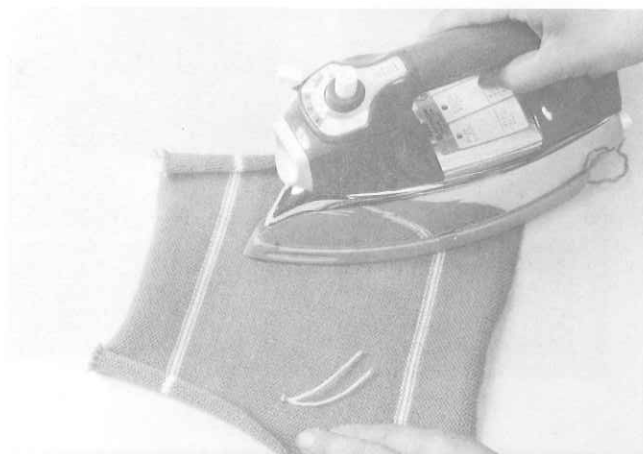
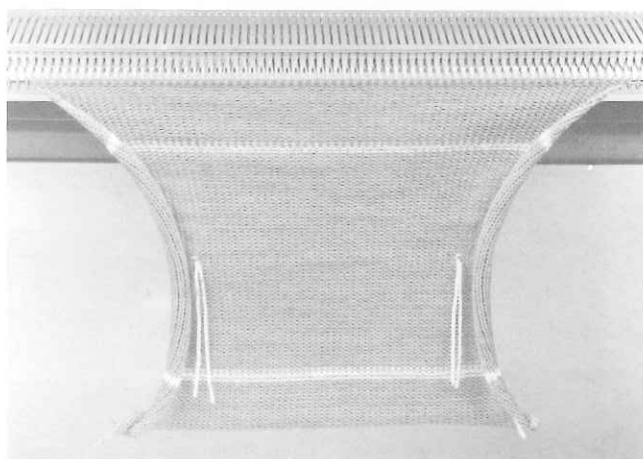
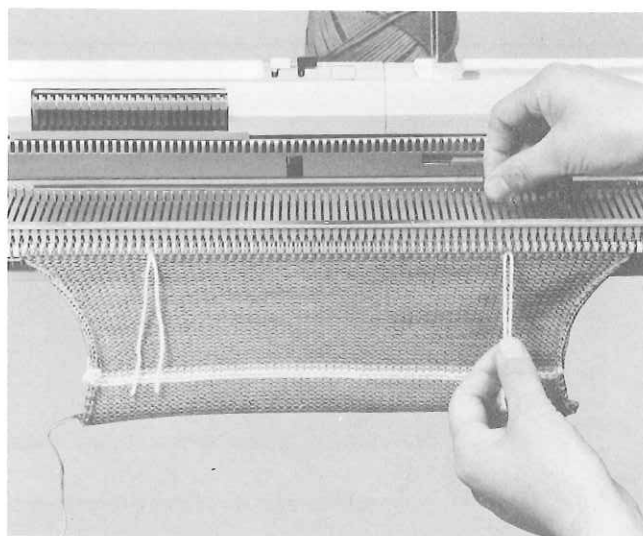
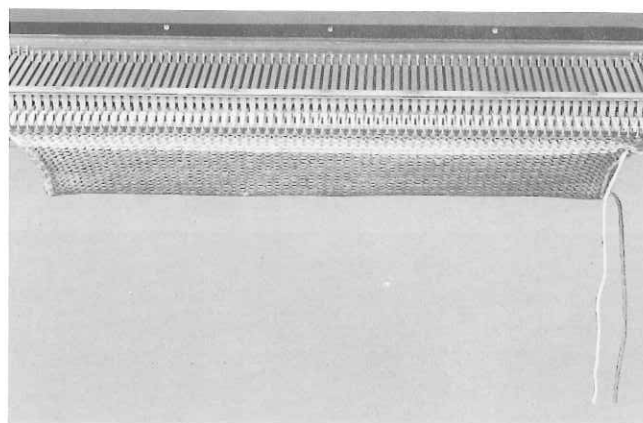

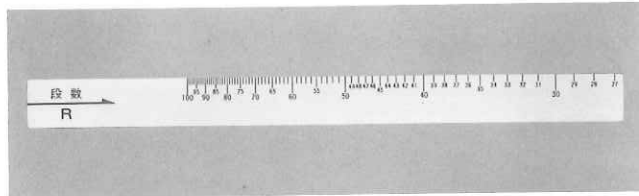
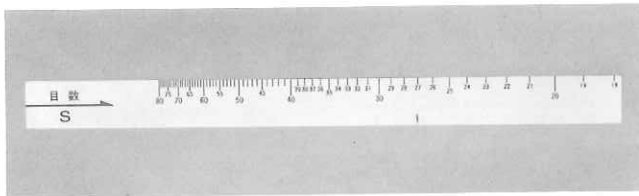

Gauge Scale

This scale is so designed to measure the length of 60 rows and the width of 40 stitches of the tension swatch, and designate them as so many stitches and rows per 10cm.

The scale is two sided. The side S is used for measuring stitches and the side R is for rows.

The photographs below show how the Gauge Scale is used.

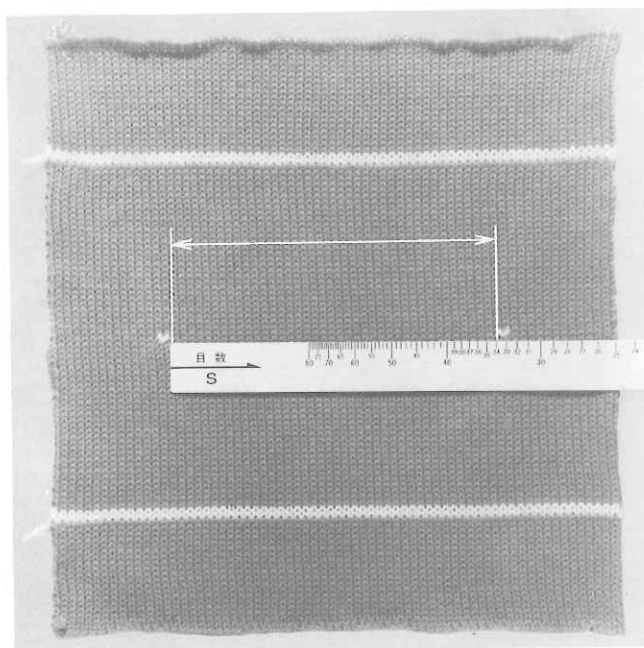

How to measure the tension swatch

Stitch (Horizontal)

Place the Gauge Scale, with the "S" side up, onto the tension swatch so as the left end of the Scale is touching the inside of the stitch in a contrast yarn. Measure to the point of the other contrast stitch and the number which corresponds with this stitch.

The Scale should be read from the side indicated by the arrow, i.e. from the left side.

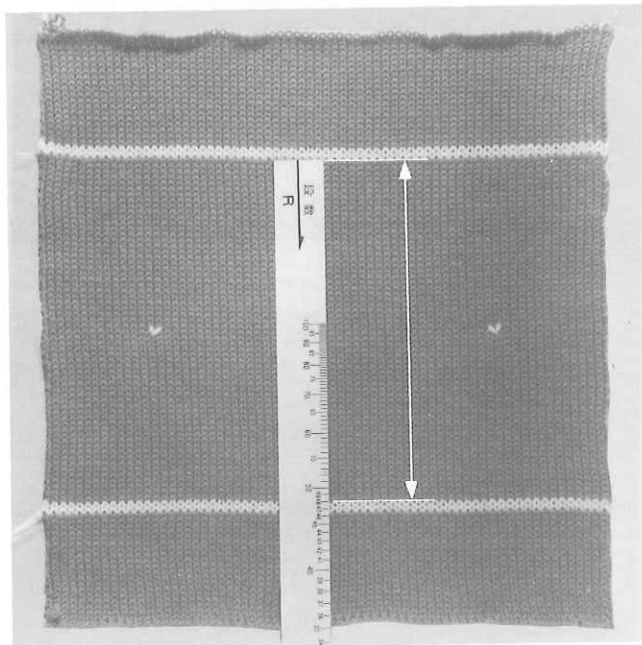

Row (Vertical)

Place the Gauge Scale, with the "R" side up, onto the tension swatch so as it covers the length in between the rows knitted in a contrast yarn. Measure this length and the number indicated on the Scale.

The Scale should be read from the side indicated by the arrow.

TAKE NOTE OF THE TENSION GAUGE.

(Number of stitches and rows)

IF A MISTAKE TAKES PLACE WHILE KNITTING

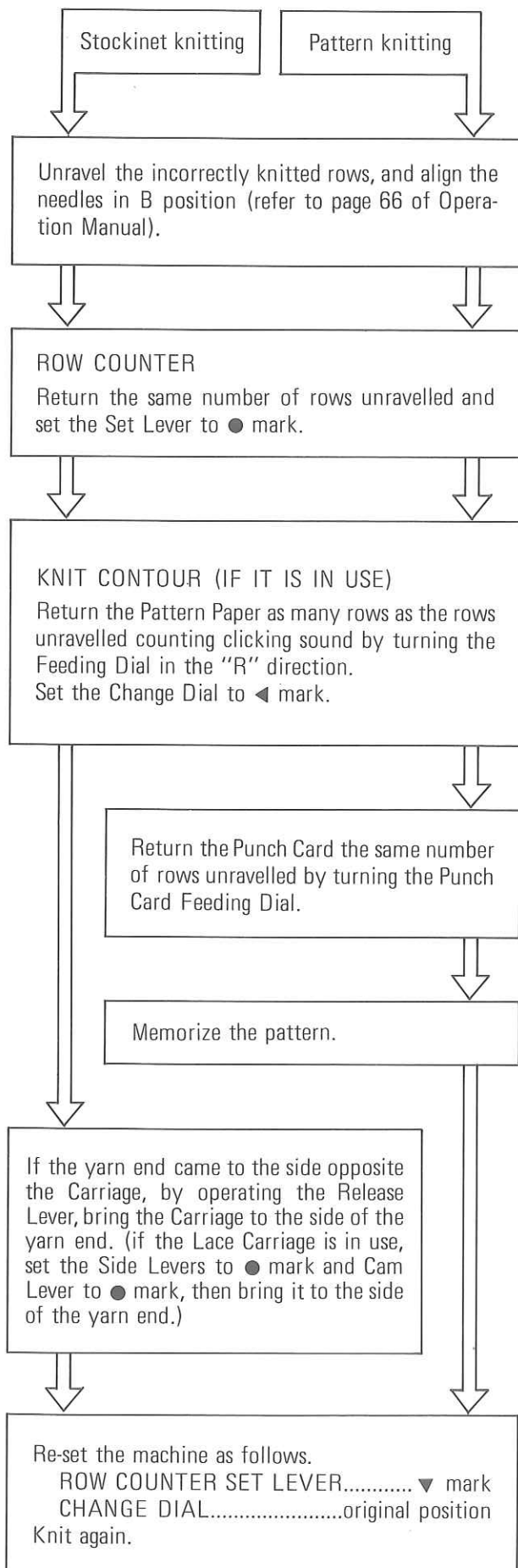

* If the vertical expansion is in use, unravel an even number of rows.

* In the lace fabric, if there are empty needles on the same row to be unravelled, fill those needles with the stitches replaced back from their adjacent needles before unravelling (refer to page 67 of Operation Manual).

* If knitting is being done with the Change Dial at 61-120, return the Pattern Paper half the number of rows unravelled. (It is suggested to unravel even number of rows.)

* If the vertical expansion is in use, return the Punch Card half the number of rows unravelled.

Example: If 3 rows have been knitted incorrectly, undone 4 rows and return the Punch Card 2 rows, Row Counter and Knit Contour 4 rows.

* In case of lace knitting, the Card Memory Numbers in a box should not be counted in the number of rows to be returned.

1. Set the Stop Knob at ● mark.

2. Lift up the Carriage by pushing the Release Lever (if the Lace Carriage is in use, set the Side Levers to ● mark and Cam Lever to ● mark), and move the Carriage as many times as required below:—

* If the yarn end is at the same side of the Carriage, move the Carriage twice across the needle bed.

* If the yarn end is at the opposite side of the Carriage, move it to the side of yarn end.

3. Re-set the Stop Knob at ▼ mark.

PATTERN PAPER

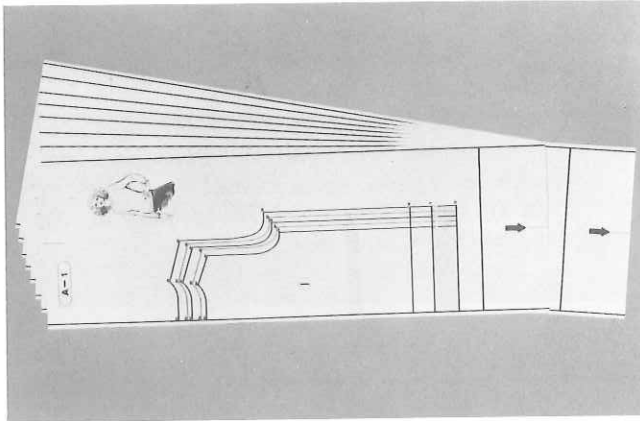

Pattern Paper Set

19 sheets of Pattern Paper representing 19 different pattern styles come with the machine incorporating the Knit Contour unit. Each pattern style is drawn to 1/2 size with 2–5 sizes which are lettered A, B, C, D & E from the smaller to larger sizes.

Selecting a pattern style

Of the 19 different pattern styles available to you, select the pattern of your choice. The table below shows the selection.

Pattern Style	Pattern Style No.	Page No.	Pattern Style	Pattern Style No.	Page No.
Lady's Pullover	A – 1	1,2,3	Child's Pullover	C – 1	25,26
Cardigan	A – 2	4,5,6	Cardigan	C – 2	27,28
Raglan Sleeve Pullover	A – 3	7,8,9	Raglan Sleeve Pullover	C – 3	29,30
Skirt	A – 4	10	Slacks	C – 4	31,32
Slacks	A – 5	11,12	Skirt	C – 5	33
One-piece Dress	A – 6	13,14,15	Top	C – 6	34
			Coat	C – 7	35
Man's Pullover	B – 1	16,17,18	Briefs	C – 8	36
Cardigan	B – 2	19,20,21	Leggings	C – 9	37
Raglan Sleeve Pullover	B – 3	22,23,24	Rompers	C – 10	38

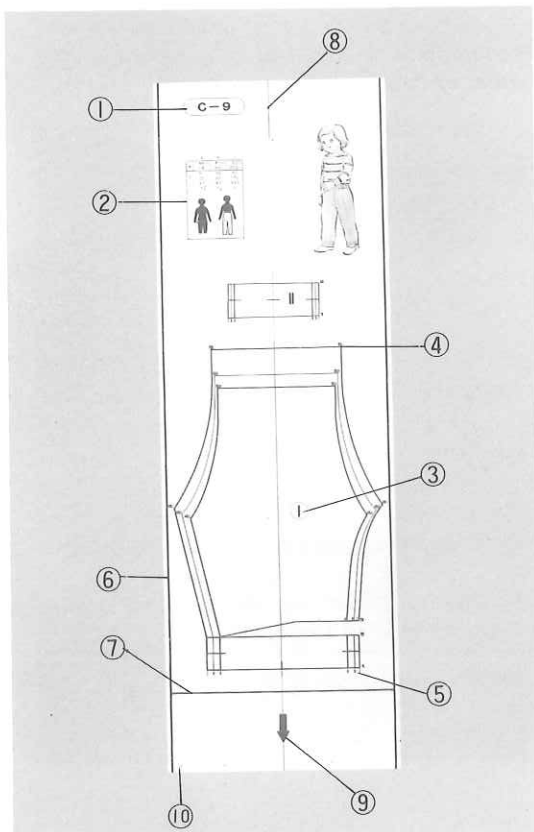

What are given on each pattern style.

- ① Pattern style number
- ② Measurement table
- ③ Pattern piece number
- ④ Shaping sequence number
- ⑤ Pattern size
(lettered A, B, C, D, E)
- ⑥ Vertical Standard Line
- ⑦ Horizontal Standard Line
- ⑧ Centre Line
(to set the Pattern Paper in correct position)
- ⑨ Arrow mark
(to set in the Knit Contour)
- ⑩ Page number

Selecting a pattern size

Measurement Table, shown opposite as an example, is given for each pattern style, and consists of two sections and each part has been graded into five sizes. On section (shaded line) shows body measurement and the other shows the pattern measurements (measurements of finished garments).

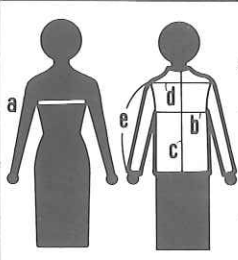
	A	B	C	D	E
	81 cm (32")	86 cm (34")	91 cm (36")	96 cm (38")	101 cm (40")
a	81 cm (32")	86 cm (34")	91 cm (36")	96 cm (38")	101 cm (40")
b	84 (33)	89 (35)	94 (37)	99 (39)	104 (41)
c	55.5 (21 ³ / ₄)	56.5 (22 ¹ / ₄)	59 (23 ¹ / ₄)	60 (23 ⁵ / ₈)	62 (24 ³ / ₈)
d	31.5 (12 ³ / ₈)	34.5 (13 ¹ / ₂)	35.5 (14)	37.5 (14 ³ / ₄)	39 (15 ³ / ₈)
e	53 (20 ⁷ / ₈)	54.5 (21 ¹ / ₂)	56 (22 ¹ / ₈)	57 (22 ¹ / ₂)	58 (22 ⁷ / ₈)

To select one size from those five sizes given, take your body measurement at the position indicated by the black figure in the Table, and select one size nearest to your requirements.

	Where to take measurements
① Bust	Over the fullest part of your bust and around back
② Waist	Around the natural waist curve line
③ Hip	Over the highest part of buttocks
④ Back width	From shoulder point to shoulder point
⑤ Length	From the first vertebra to the disired position
⑥ Sleeve length	From shoulder point to wrist

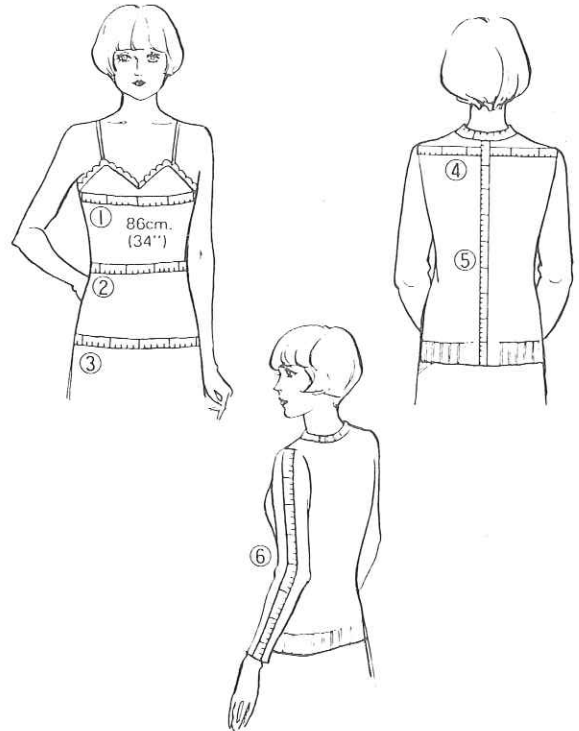

Example: If your body measurement (bust) is 86cm. (34"), select size B.

Take the measurement of the other parts of your body as illustrated opposite and listed below, and check them against the selected pattern size.

The pattern measurements include ease allowance.

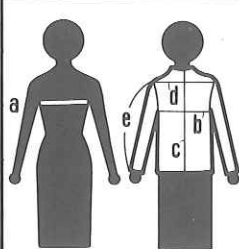
	A	B	C	D	E
	81 cm (32")	86 cm (34")	91 cm (36")	96 cm (38")	101 cm (40")
a	81 cm (32")	86 cm (34")	91 cm (36")	96 cm (38")	101 cm (40")
b	84 (33)	89 (35)	94 (37)	99 (39)	104 (41)
c	55.5 (21 ³ / ₄)	56.5 (22 ¹ / ₄)	59 (23 ¹ / ₄)	60 (23 ⁵ / ₈)	62 (24 ³ / ₈)
d	31.5 (12 ³ / ₈)	34.5 (13 ¹ / ₂)	35.5 (14)	37.5 (14 ³ / ₄)	39 (15 ³ / ₈)
e	53 (20 ⁷ / ₈)	54.5 (21 ¹ / ₂)	56 (22 ¹ / ₈)	57 (22 ¹ / ₂)	58 (22 ⁷ / ₈)

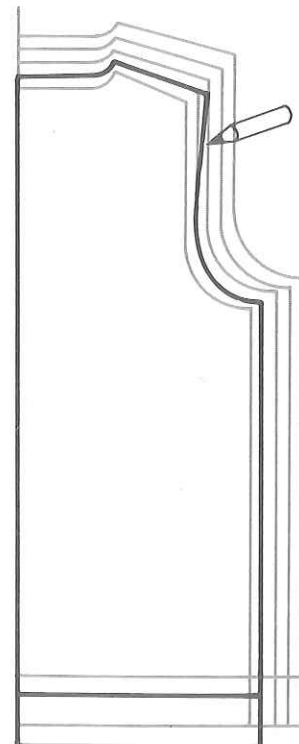

If the body measurements are notably different from the pattern measurements, adjust the length and width of the pattern as shown.

SETTING THE KNIT CONTOUR

The Knit Contour tells you where to cast on/cast off and the number of stitches to be increased/decreased while knitting a garment with the use of the Pattern Papers.

- ① Paper Lever
- ② Clip
- ③ Paper Holder
- ④ Paper Slit
- ⑤ Row Number Window
- ⑥ Row Number Dial
- ⑦ Feeding Dial
- ⑧ Change Dial
- ⑨ Feed Lever

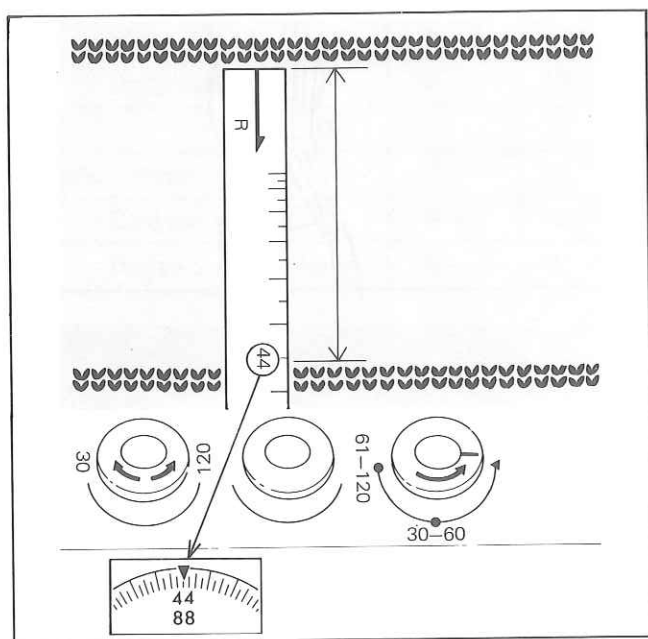
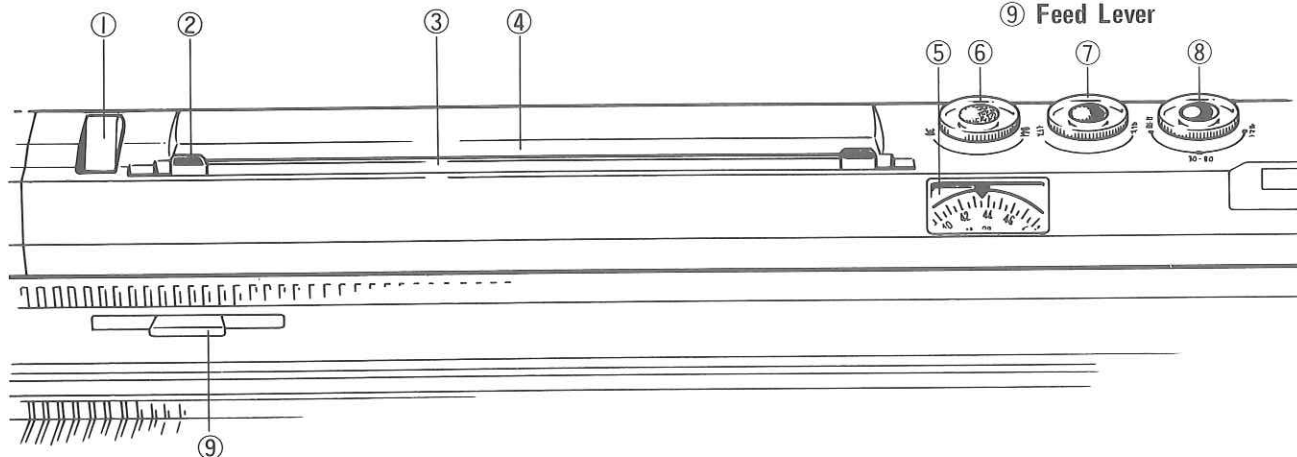

After you have succeeded in ascertaining the correct tension gauge, set the Knit Contour in the following order.

- i Set the row number.
- ii Set the Pattern Paper.
- iii Select a Stitch Scale and set in place.

Set the row number

The number read on the Gauge Scale is the base for setting the row number.

- (1) Set the Change Dial to ◀.
- (2) Turn the Row Number Dial to set the red pointer in the Row Number Window to correspond with the number read on the Gauge Scale.

Important: Be sure to set the Change Dial to ◀ whenever setting the Row Number.

- (3) Set the Change Dial either to 30-60 or 61-120.

* When the gauge row number is less than 60, set the Change Dial at 30-60, and the upper numerals function.

* When the gauge row number is more than 60, set the Change Dial to 61-120, and the lower numerals function.

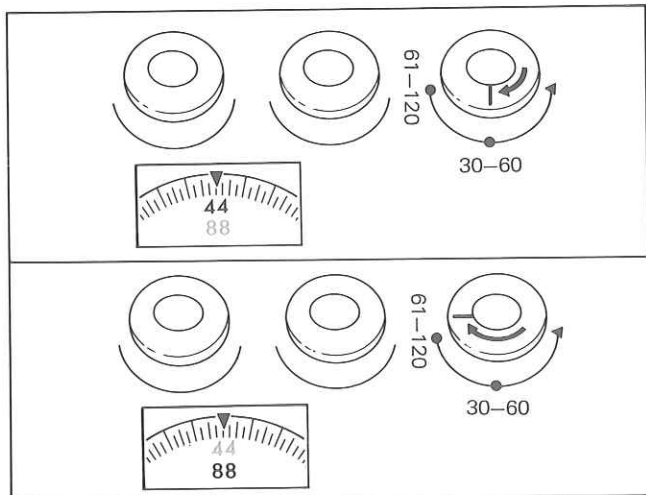

Set the Pattern Paper

- (1) Set the Paper Lever to the ● mark.
(The Paper Holder is opened.)
When the Paper Lever is set at...
▼..... the Pattern Paper is securely held.
●..... the Pattern Paper is free to move.
- (2) Insert the selected Pattern Paper into the Paper Slit in the direction of its arrow mark.

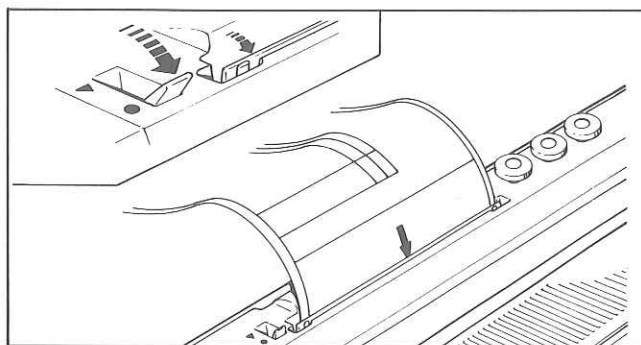

- (3) After you have inserted the Pattern Paper 5–6cm., set the Paper Lever back to ▼ mark. Feed the Pattern Paper by turning the Feeding Dial to "F" direction until the bottom end of the Pattern Paper comes out from the rear slit.

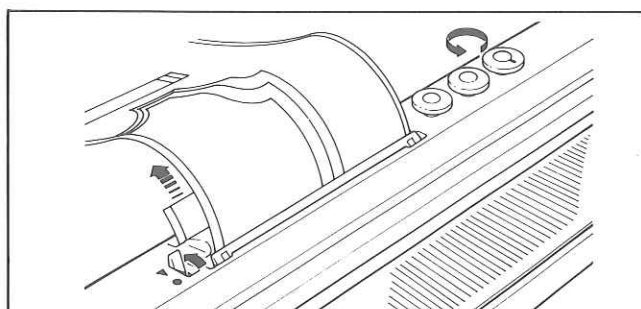

- (4) Re-set the Paper Lever to the ● mark. Hold both ends of the Pattern Paper, joining the Centre Line of the front and back so that they are in a straight line.

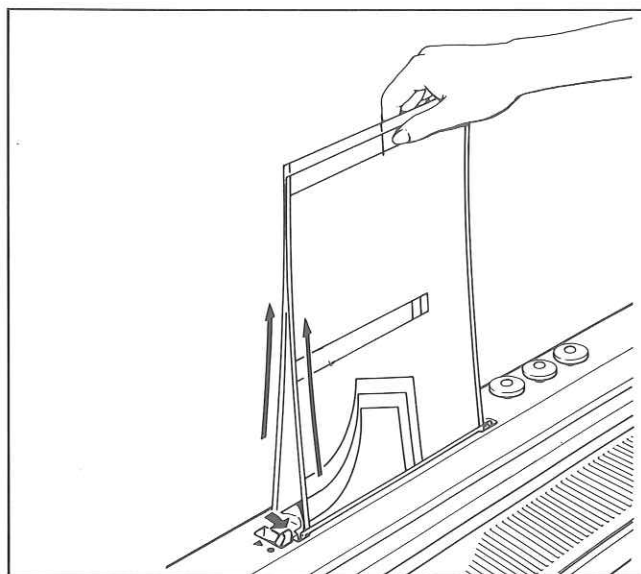

- (5) Afterwards, set the Paper Lever back to the ▼ mark.

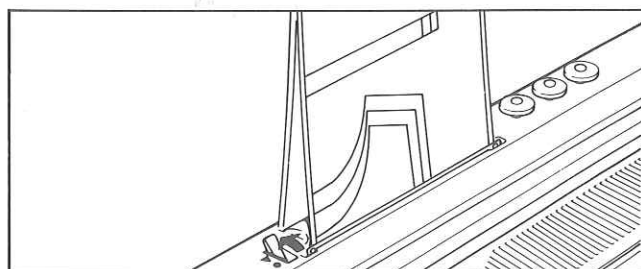

Select a Stitch Scale and set in place

A set of 8 Stitch Scales and a set of 6 Centre Scales accompany the machine for the use on the Knit Contour.

The Scale is so designed to represent various sizes of a stitch measured by the Gauge Scale, and regulates the necessary number of stitches for shaping a garment when in use with the Pattern Paper.

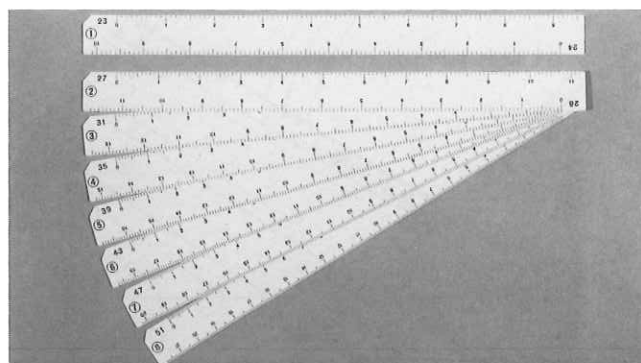

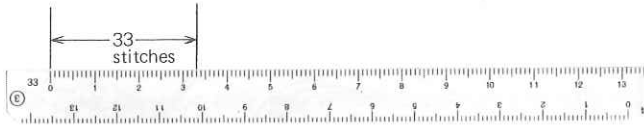

Scale No.	①	②	③	④	⑤	⑥	⑦	⑧
Range of Stitches	23 } 26	27 } 30	31 } 34	35 } 38	39 } 42	43 } 46	47 } 50	51 } 54

Scale No.	⑪	⑫	⑬	⑭	⑮	⑯
Range of Stitches	23 } 26	27 } 30	31 } 34	35 } 38	39 } 42	43 } 44

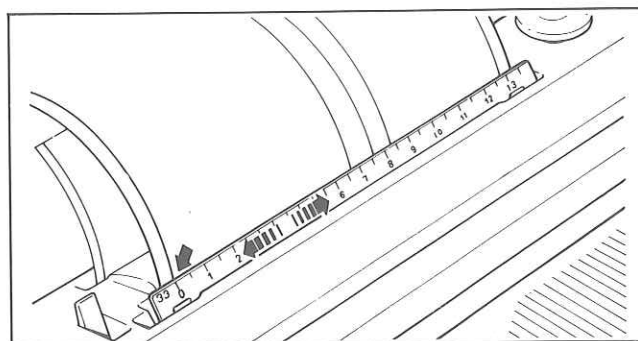
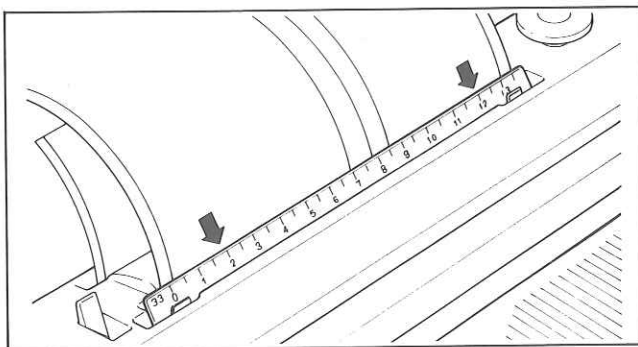
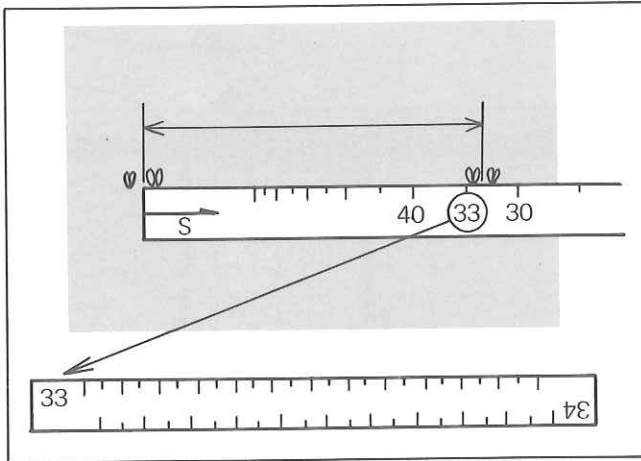

The number at the corners of the Scale denote the number of stitches determined by using the Gauge Scale.

Example: The side denotes 33 actual stitches over a 10cm. width.

Stitch Scale

8 scales are numbered ① through ⑧ and each of them covers four stitch sizes.

Centre Scale

6 scales are numbered ⑪ through ⑯ and each of them covers four stitch sizes, but the scale ⑯ covers only two stitch sizes.

The Centre Scales are used for Slacks, Leggings, etc.

- (1) Select the Stitch Scale with the number equal to that of the stitches counted on the swatch.

(For example, if the number of stitches read on the Gauge Scale was 33, the Stitch Scale having 33 at the corner should be selected.)

- (2) Insert the selected Stitch Scale into the Clips of the Paper Holder so as the selected number is facing you at the left side.

- (3) Adjust the Stitch Scale to fit its "0" mark with the Vertical Standard Line on the Pattern Paper.

When using the Centre Scale, set its "0" mark at the Centre Line on the Pattern Paper.

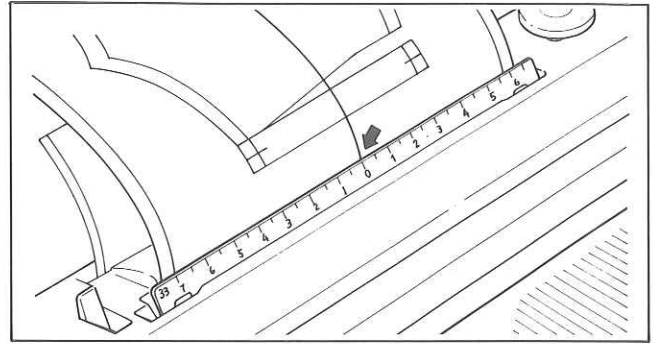

- (4) Return the Pattern Paper by turning the Feeding Dial to "R" direction till its Horizontal Standard Line appears at the Stitch Scale and adjust the setting of the Stitch Scale so as it is parallel to the Standard Line.

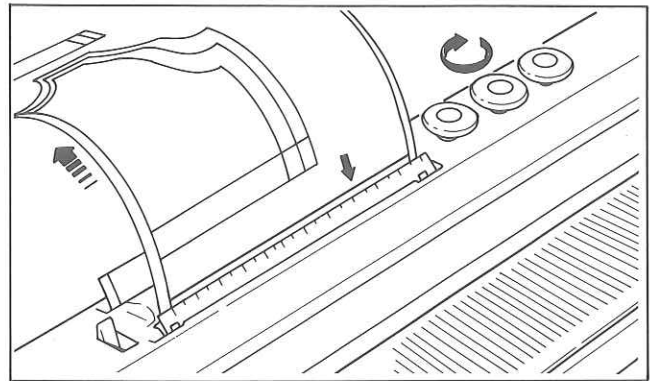

To operate the Knit Contour...

Slide the Carriage across till it activates the Feed Lever located under the Row Counter which will rotate the Pattern Paper.

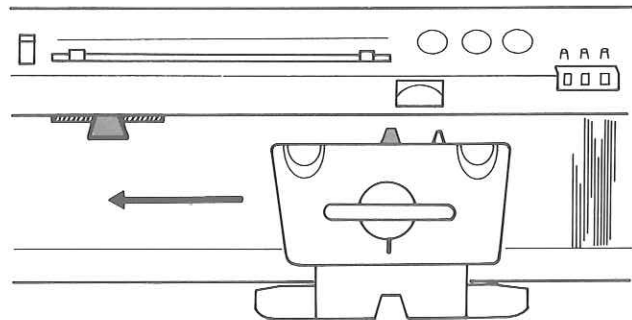

TO UNDERSTAND PRINCIPLES OF THE KNIT CONTOUR

The **tension gauge** determined over the tension swatch is the base for making a garment to its correct size.

Example: Tension Gauge in 30 stitches by 40 rows.

The tension Gauge, designated as so many stitches and rows per 10cm., is represented by the Stitch Scale and row number. (30 stitches for Stitch Scale, and 40 rows for row number as an example.) They are considered to establish the same number of stitches and rows per 10cm. throughout the pattern in the Knit Contour (actually for each 5cm. square as the pattern is reduced to 1/2 size).

Those selected Stitch Scale and row number regulate the number of stitches and rows, and require the following basic technique at each step of knitting.

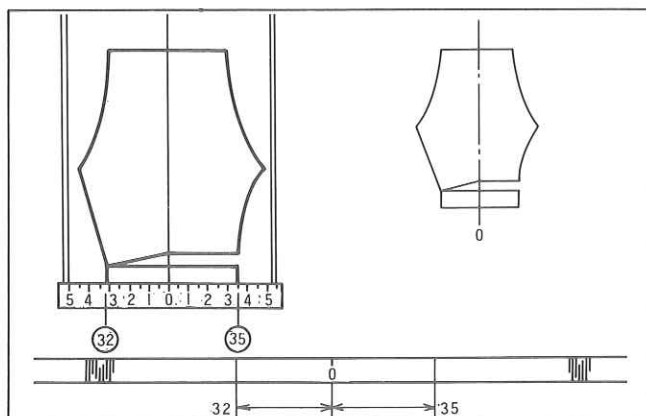
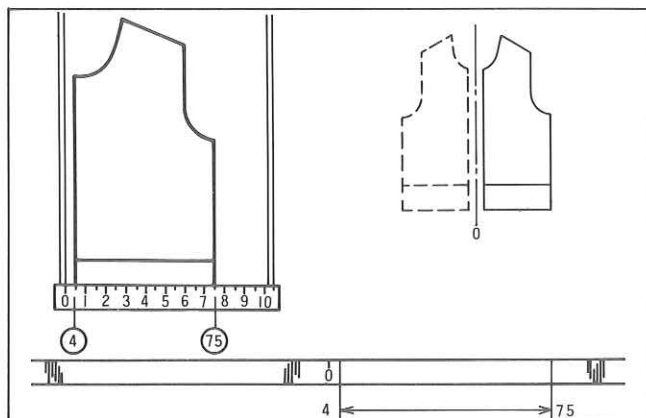
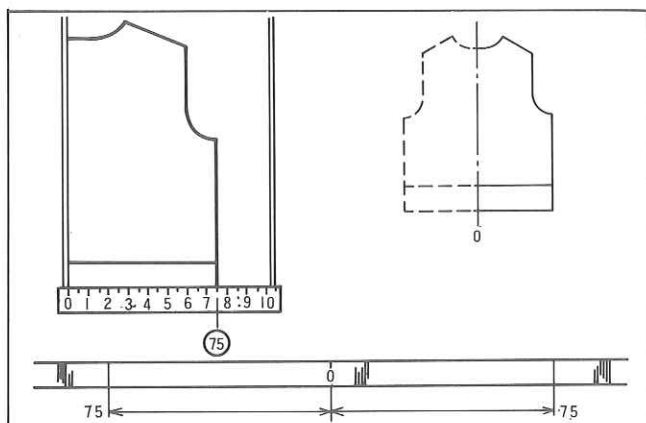
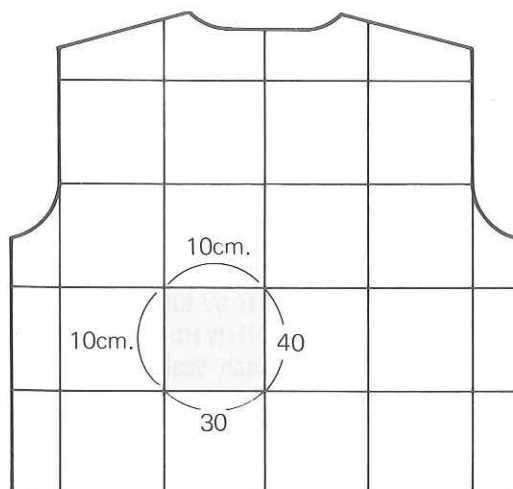

Cast on

- (A) Pattern styles given half of it centering the Vertical Standard Line.
(Example: Pullover, Skirt, etc.)

Cast on the same number of stitches as read on the Stitch Scale on both sides of "0" on the Needle Bed.

Shape the fabric symmetrically by applying the same technique on both sides.

- (B) Patterns given on the paper off the Vertical Standard Line.

(Example: Front of Cardigan, etc.)

Knit the right front and left front separately.

Cast on the same number of needles on either side of "0" on the Needle Bed and shape each side of the fabric differently.

To knit the other piece with the same pattern, read the number of stitches on the right side for the left and vice versa.

- (C) Whole pattern is given.

(Example: Slacks, Leggings, etc.)

Use a Centre Scale and set its "0" at the Centre Line on the Pattern Paper.

Read the number of stitches on the Scale for the right side and left side separately and cast on the same number of stitches.

Shape each side differently following the contour line, and to knit the other piece with the same pattern, read the number of stitches, on the right for the left and vice versa.

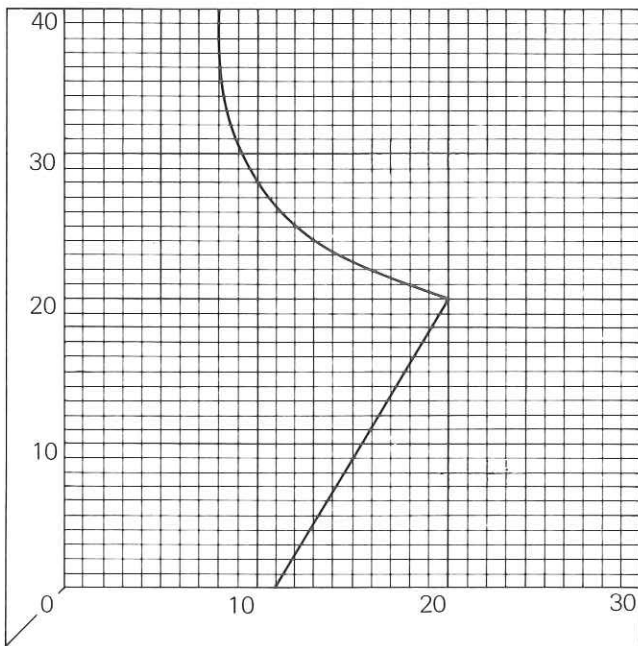

As the pattern paper advances in the Knit Contour, the crossing point of the contour line with the Stitch Scale shifts and according to the selected Stitch Scale and the row number, this will indicate where and what number of stitches to increase or decrease to obtain the correct shaping for garment.

Basic techniques as required by the contour line are shown below as an example.

Decrease

- (1) 46 stitches are now on the machine.
- (2) As the Pattern Paper advances, the contour line crosses the Stitch Scale at 42.
Decrease 4 stitches to have 42 stitches on the machine.

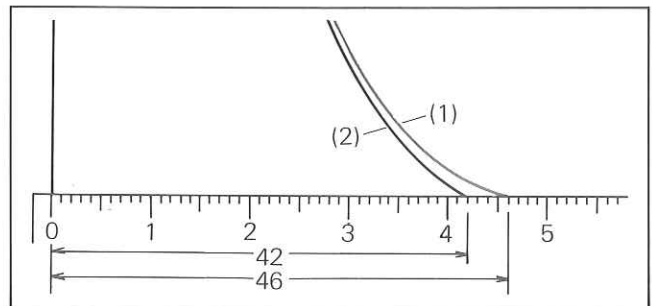

Increase

- (1) 33 stitches are now on the machine.
- (2) As the Pattern Paper advances, the contour line shows 34 stitches at its crossing point with the Stitch Scale.
Increase 1 stitch to have 34 stitches on the machine.

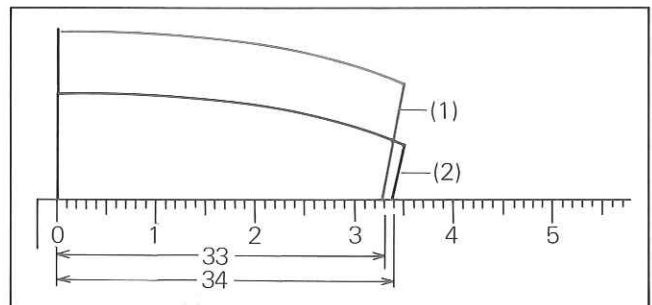

Partial Knitting by decreasing stitches

- (1) 53 stitches are now in B position on the machine.
- (2) As the Pattern Paper advances, the contour line shows 48 stitches at its crossing point with the Stitch Scale on the following row.
Push 5 needles to holding position on the side opposite the Carriage to have 48 stitches in B position.

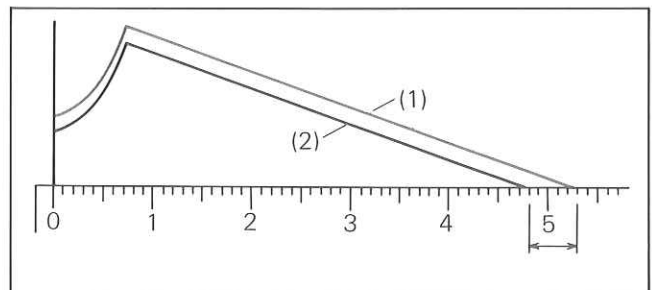

Partial Knitting by increasing stitches

- (1) 22 stitches are now in B position on the machine.
- (2) As the Pattern Paper advances, the contour line shows 28 stitches at its crossing point with the Stitch Scale on the following row.
Push 4 needles back to knitting position to knit 28 stitches on the next row.

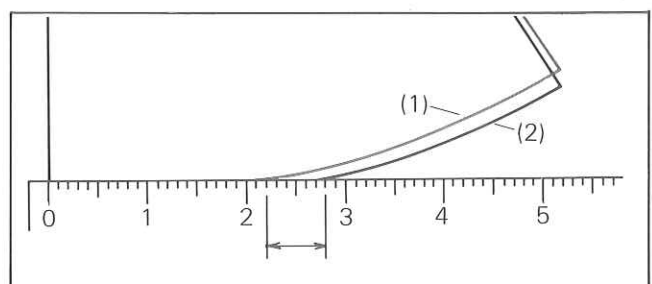

KNITTING ON THE KNIT CONTOUR

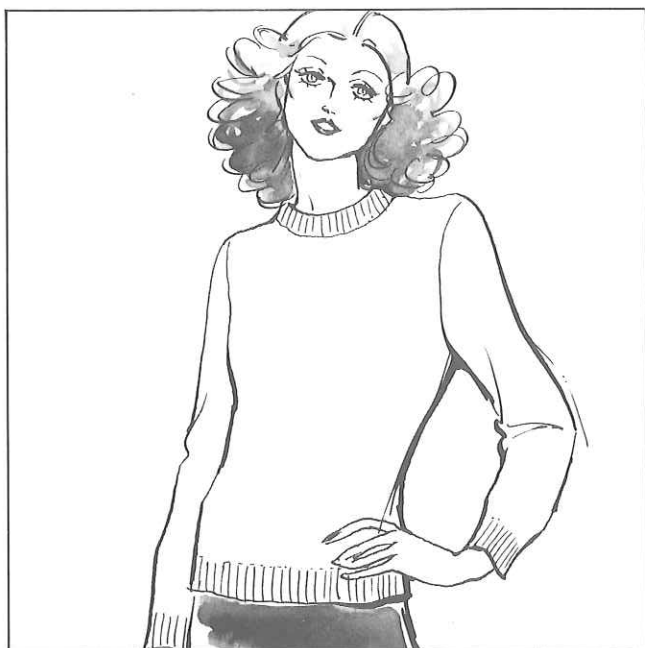

Following the instructions below, practise garment knitting with the use of the Pattern Paper.

The LADY'S PULLOVER (A-1) or MAN'S PULL-OVER (B-1) is taken as an example, and the techniques necessary for it are applicable to other types of garment.

The instructions given after the **P** mark should be followed when the Punch Card is in use.

Before starting to knit, make sure of the following preliminary steps:—

- (1) Select a pattern and adjust the size if notably different from your size.
- (2) Take a tension gauge.
- (3) Set the Knit Contour (attachment) correctly.

Note: If you made a mistake while knitting, correct it referring to page 4.

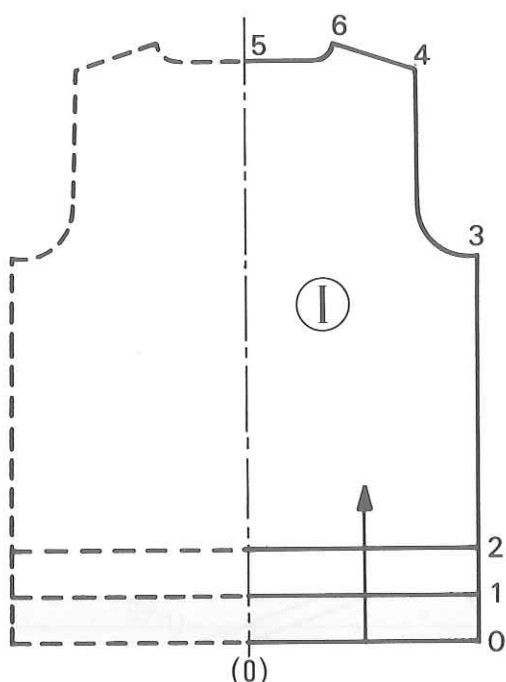

IF YOU ARE KNITTING ONLY ON THE KNITTER, WORK MOCK RIB FOR WELT, CUFF AND NECK-BAND IN PLACE OF K1.P1. RIB.

Back — pattern (I)

- (1) To work mock rib...
 - Set the Pattern Paper to starting line "0" for mock rib, set the Change Dial to ◀, and set the Stop Knob to ● mark.
 - Read the number of stitches required for cast on.
 - Push up the same number of needles on both sides of centre(0) to B position and arrange them as shown.

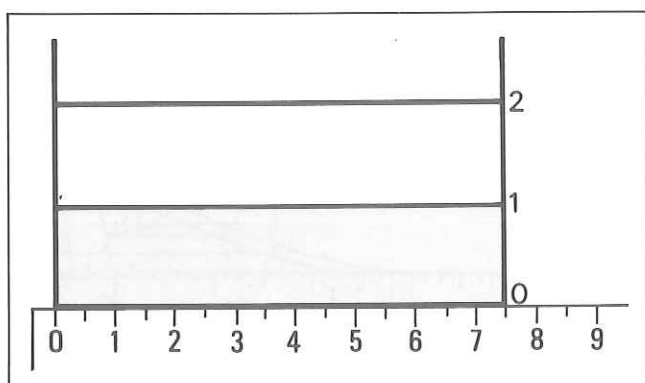

- With waste yarn, cast on and knit several rows.
- Knit 1 row with Ravel Cord.
- Set the Change Dial at 30–60 or 61–120 (refer to page 7).
- Set the Stitch Dial 2–3 numbers lower than the main tension and knit with main yarn up to "2".
- Push up the empty needles to B position.
- Turn up by placing the loops of the first row knitted in main yarn onto the corresponding needles. (Refer to page 31.)

To work K1.P1. rib...

- Set the Pattern Paper to starting line "1". for K1.P1. rib.
- Read the number of stitches required for cast on and push up the same number of needles to B position on both the Knitter and Ribber.
- Arrange the needles for knitting K1.P1. rib by using the Needle Pusher and cast on.
- Knit up to "2" in K1.P1. rib.
- Transfer the Ribber stitches onto the Knitter and drop the Ribber to its lowest position.
- Exchange the Ribber Arm for the Knitter Arm, and remove the Ribber Weights and Cast on Comb from the fabric.

P Insert a Punch Card and set the Stop Knob at ● mark.

Knit 1 row in stockinet to memorize the pattern. Set the Cam Lever to the stitch type you are going to knit and set the Stop Knob to ▼ mark.

(2) Set the Stitch Dial for the main tension and knit straight up to the armhole "3".

(3) For the armhole, stitches must be decreased equally on both sides following the contour line. Continue to knit up to the shoulder point "4".

(4) To shape the shoulder, apply decreasing (refer to page 24), and knit up to neckline "5".

(5) At the neckline, divide into three sections, right, centre straight and left to work each section separately.

(6) Read on the Stitch Scale the number of stitches for the centre straight section (a) and either the right or left section (b), opposite the Carriage, and hold their stitches (refer to page 28).

P Mark the present row number of the Punch Card.

(7) For the needles in B position, decrease the stitches at the neck and on the shoulder, up to the neck point "6".

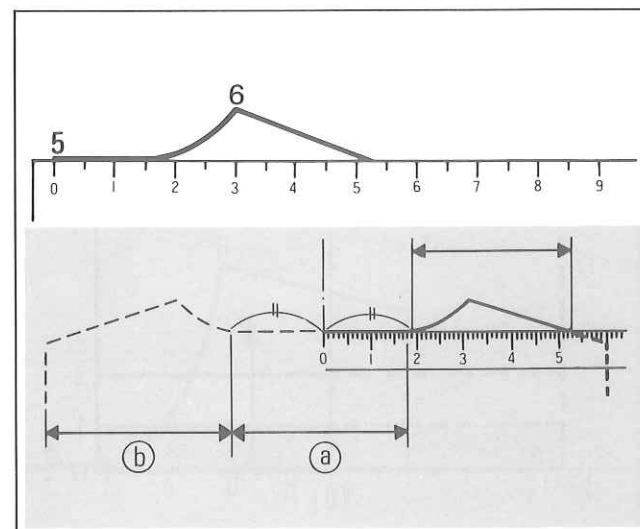
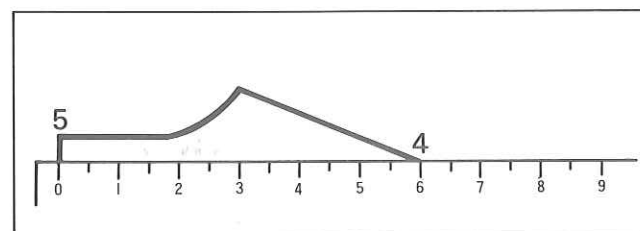
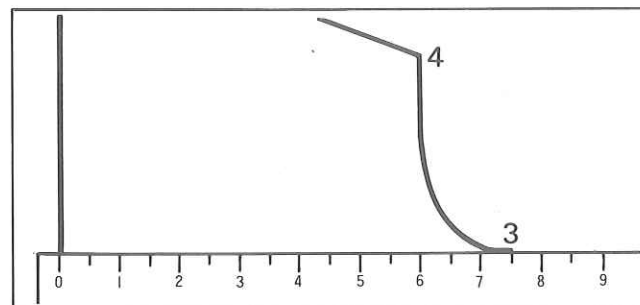
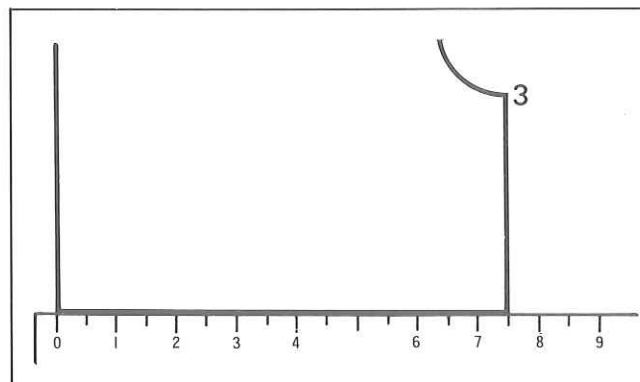
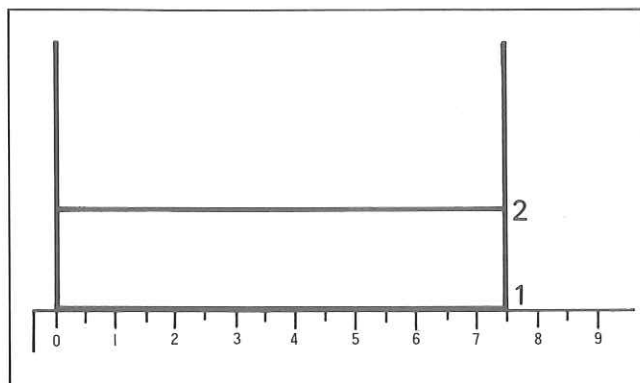

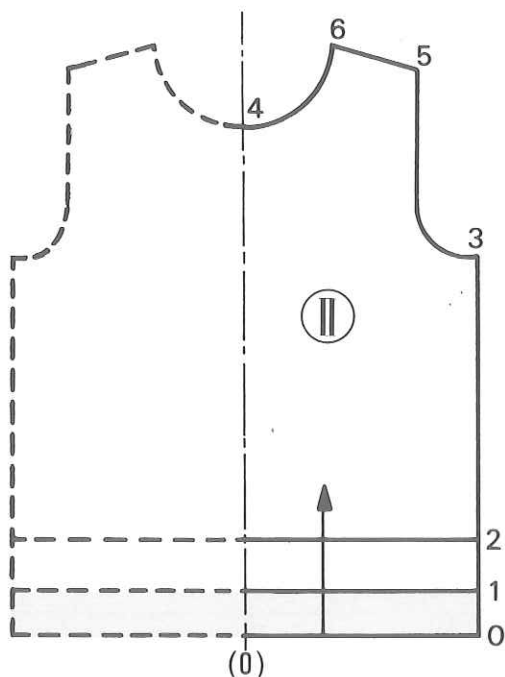
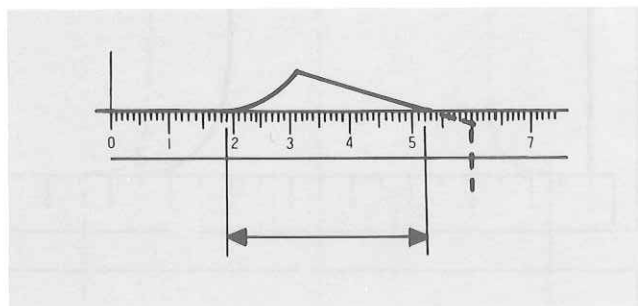
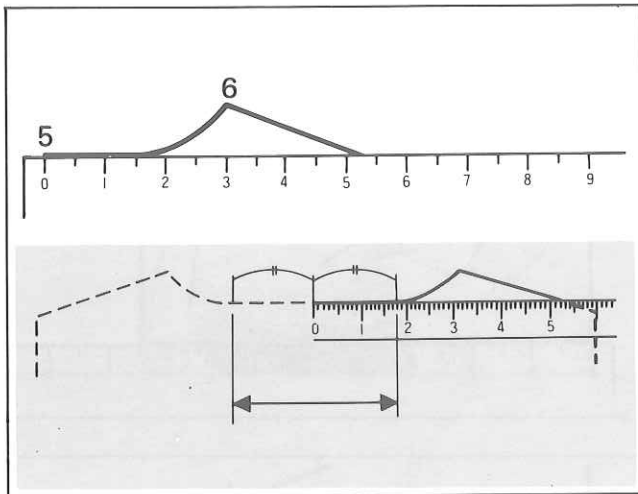
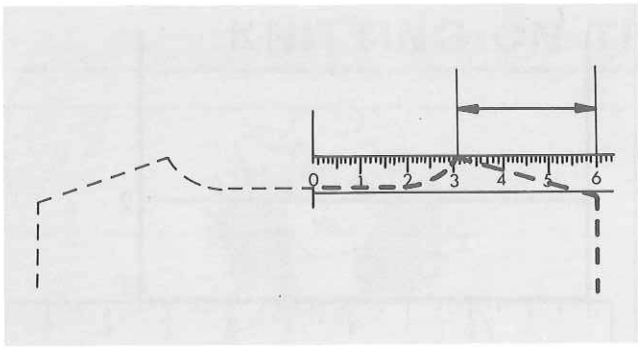

- (8) At the neck point, cut the main yarn, push the needles for the shoulder from holding position to knitting position and knit several rows of waste knitting over them (refer to page 29). Remove the section from the machine and push the empty needles back to A position.

P Return the Punch Card to the same row number which you marked, and set the Stop Knob to the ● mark.

- (9) Return the Pattern Paper to the neckline "5" and read the number of stitches for the centre straight section. Push those needles to knitting position.

Set the Change Dial to ◀ and knit several rows of waste knitting over those needles.

Remove the section from the machine and push back the empty needles to A position.

- (10) For the second shoulder, apply the same techniques as done for the first shoulder but reverse shaping.

(a) Have the Carriage on the side of the first completed shoulder and re-set the Change Dial to the original setting.

(b) Replace the stitches which represent the remaining part of the shoulder, and align them in knitting position.

P Re-set the Cam Lever to the stitch type of the main knitting and set the Stop Knob to ▼ mark.

(c) Thread the main yarn into the Yarn Feeder and knit shaping the neck edge and the shoulder by decreasing stitches.

Front — pattern II

- (1) Set the Pattern Paper for the front and knit in the same manner up to the neckline "4" as done for the back.
- (2) At the neckline, divide into three sections, right, centre straight and left, to work each section separately.

P Mark the present row number of the Punch Card and set the Stop Knob to the ● mark.

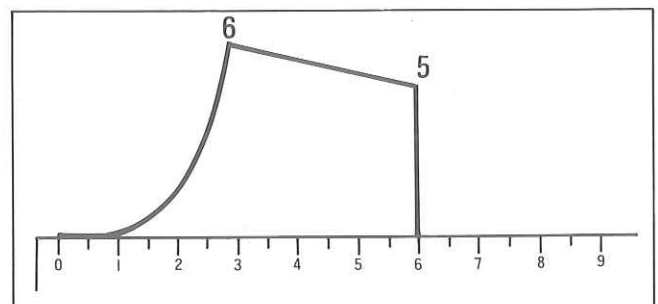

- (3) Read on the Stitch Scale, the number of needles for the centre straight and side section nearest the Carriage and push these needles to holding position.

Set the Change Dial to ◀ and knit several rows of waste knitting over needles in B position.

Remove the section from the machine and push the empty needles back into A position (note needle numbers).

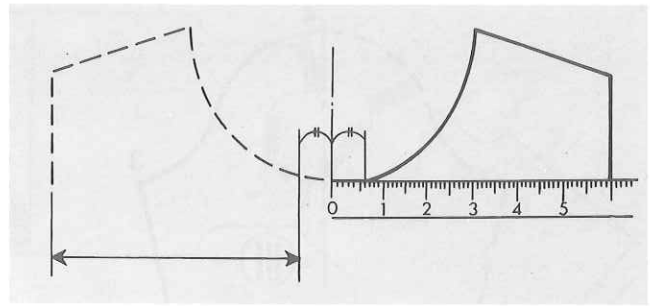

- (4) Push the needles for the centre straight section of the neckline to knitting position and knit several rows of waste knitting.

Remove the section from the machine, (note the needle numbers) and push the empty needles back into A position.

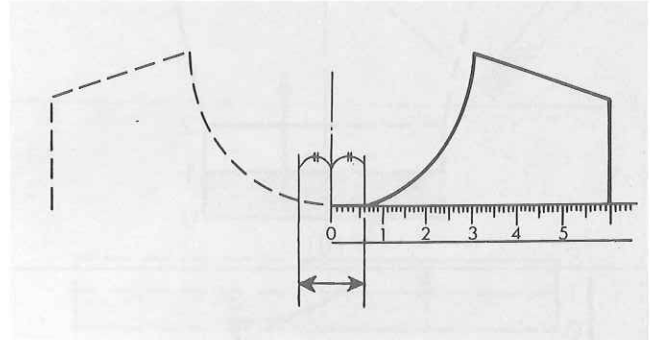

- (5) Bring the Carriage to the side of the yarn, using the Transfer Tool, replace the stitches manually from holding to knitting position.

P Re-set the Cam Lever to the stitch type of the main knitting and set the Stop Knob to ▼ mark.

Re-set the Change Dial to the original setting and continue to knit shaping the neck edge by decreasing stitches up to the shoulder point "5".

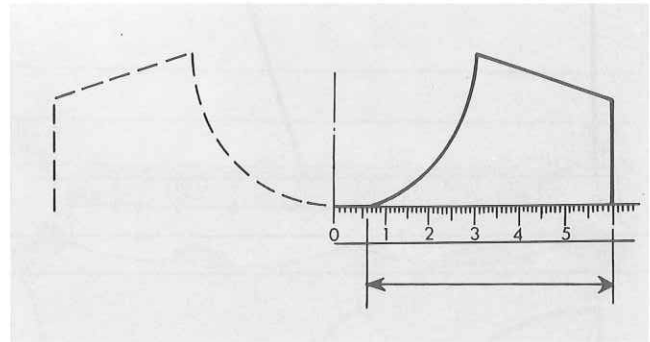

- (6) From the shoulder point, shape the shoulders in partial knitting (decreasing stitches) and at the same time continue to decrease at the neck edge up to the neck point "6".

- (7) At the neck point, cut the main yarn, push the needles for the shoulder from holding position to knitting position.

P Return the Punch Card to the card memory number you marked on the row at the neckline and set the Stop Knob to ● mark.

Knit several rows of waste knitting, remove the section from the machine and push the empty needles back into A position.

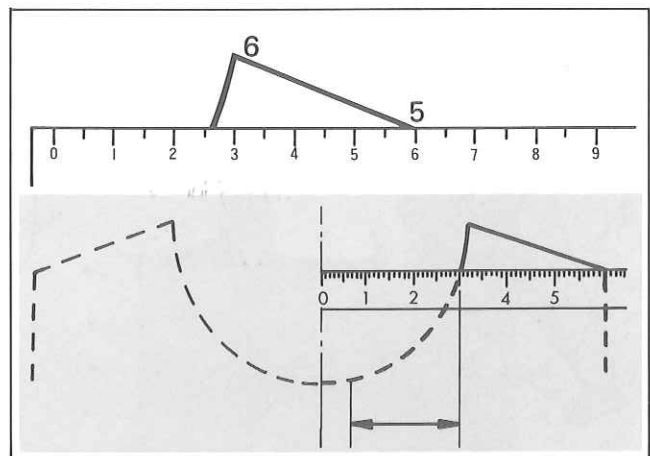

- (8) Return the Pattern Paper to the neckline "4" and push the needles for the second half up into B position, and fill the needles with the stitches of the last row knitted in the main yarn.

P Re-set the Cam Lever to the stitch type of the main knitting and set the Stop Knob to ▼ mark.

Knit in the same manner as for the first half, but reverse shaping.

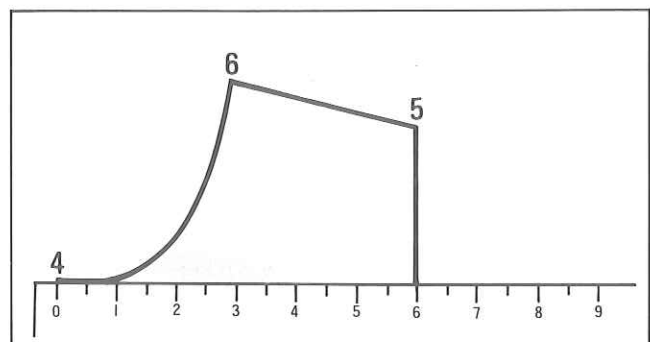

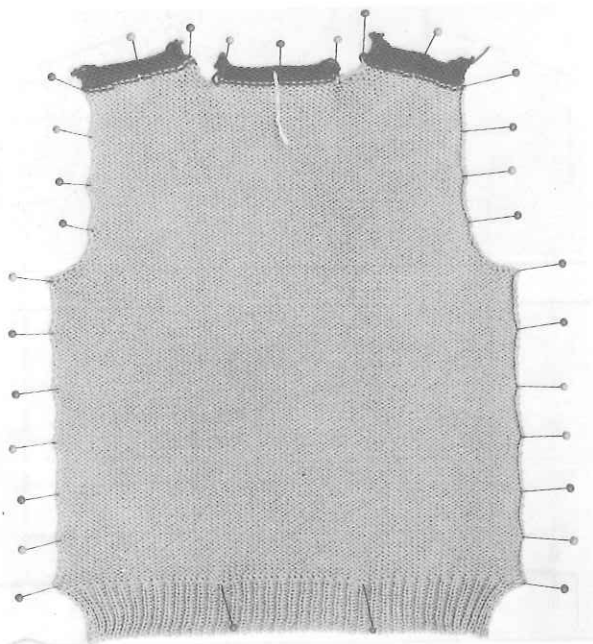
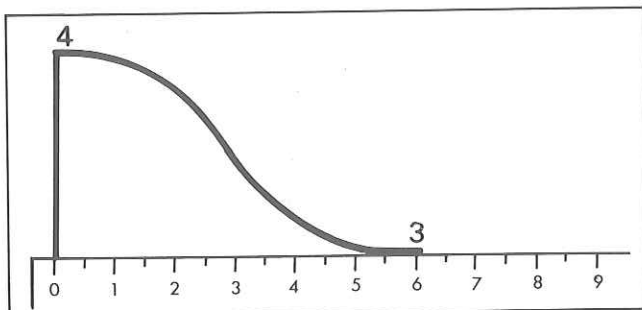
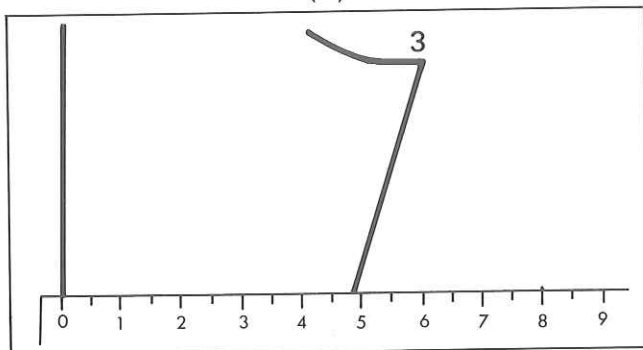
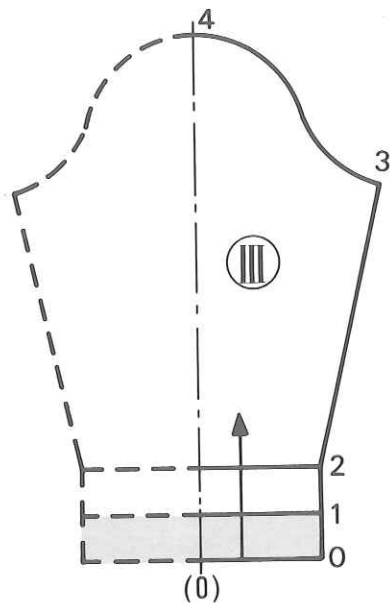

Sleeves — pattern III

Knit two pieces in the same pattern.

- (1) Set the Pattern Paper for the sleeve to the starting line "0" or "1" for knitting and read the number of stitches for the cast on.
In the same manner as done for the welt (refer to page 13 or 14), knit up to "2".

P Insert a Punch Card and set the Stop Knob at ● mark.

Knit 1 row in stockinet to memorize the pattern. Set the Cam Lever to the stitch type you are going to knit and set the Stop Knob to ▼ mark.

- (2) Set the Stitch Dial and Row Number Dial for the main tension.

Knit up to "3", increasing stitches on both sides at the same time.

- (3) Shape the top by decreasing stitches.

- (4) Put a yarn mark at the centre of the top, and cast off the stitches (refer to page 30 or 31).

Blocking and pressing

After knitting the pieces of your garments, you must lay them flat and pin them out to their correct shape and size.

Then press them lightly with a warm iron over a damp cloth and leave the pieces to dry before removing the pins.

Join the right shoulder

With the right sides facing pick up the stitches of the last row knitted in the main yarn and place them onto the same needles.

Knit 1 row with the Main Carriage, setting the Stitch Dial at 8–9, and cast off by using a Tappet Tool.
(Cast off using the Tappet Tool – page 30)

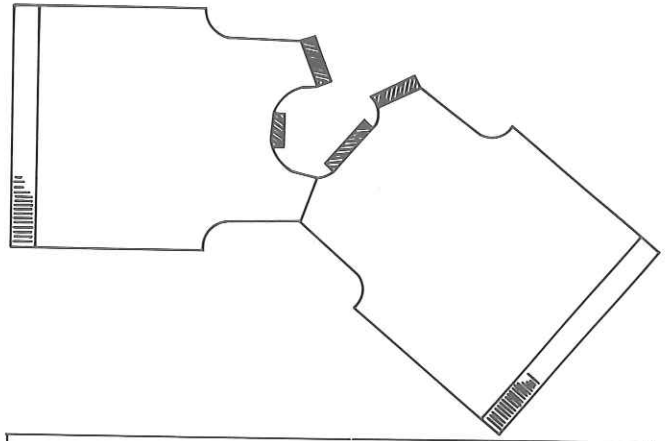

Neckband – pattern ④

Set the Pattern Paper for the neckband to the starting line "0" or "1", then knit in the same manner as done for the welt (refer to page 13 or 14).

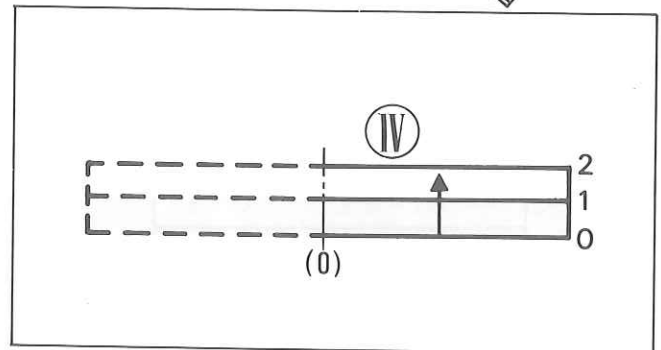

Join the neckband to the neck edge

Pick up the stitches from the neck edge evenly with the wrong side facing you and place them onto the same needles.

Knit 1 row with the Main Carriage, setting the Stitch Dial at 8–9, and cast off by using a Tappet Tool.
(Cast off using the Tappet Tool – page 30)

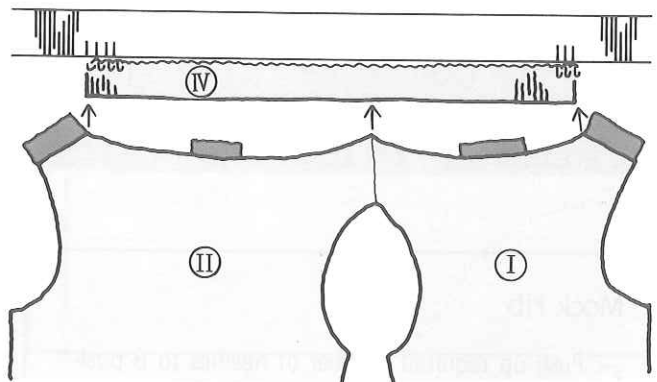

Making up

- (1) Pick up and finish off the left shoulder to correspond with the right shoulder.
- (2) Join the side, neckband and sleeve seams.
(Blind stitch – page 35).

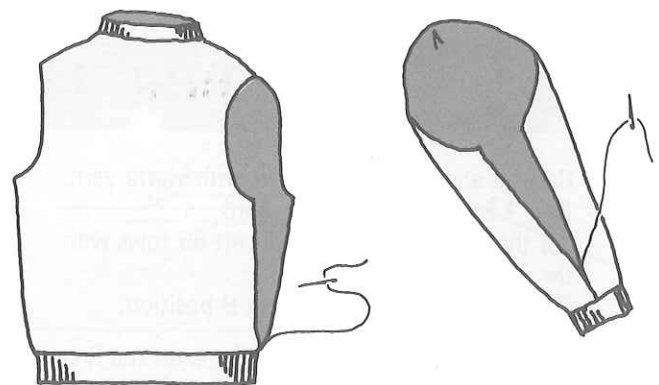

- (3) Turn the garment to the wrong side and slip the sleeves into the armhole. Pin them as illustrated and work slip stitch along the edges.
(Slip stitch – page 35)

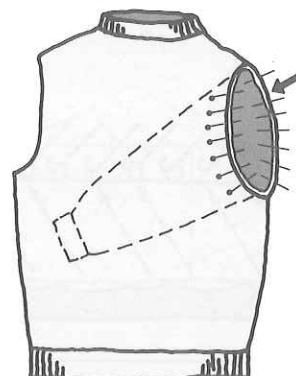

KNITTING WITHOUT USING THE KNIT CONTOUR

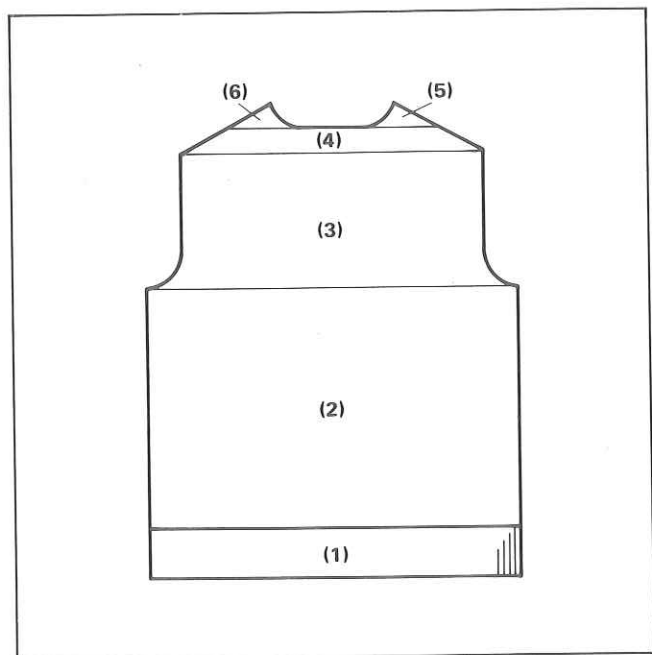

The instruction below explains how to knit a garment without using the Knit Contour. A pullover is taken as an example based on the size and the tension gauge as shown below.

Measurements of finished garment

Bust 94cm.

Length 59cm.

Back Width 36cm.

Sleeve Length 56cm.

Material needed

3-ply (medium fine) yarn 250gs.

Tension Gauge

38 stitches by 54 rows to 10cm. sq.
measured over stockinet.

Stitch Dial 5

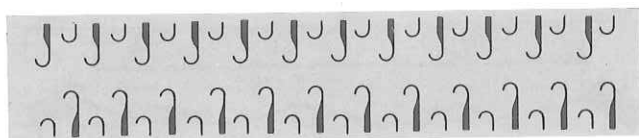

Mock rib

- Push up required number of needles to B position and arrange them as shown below.

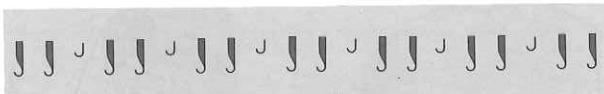

- Cast on and knit several rows with waste yarn.
- Knit 1 row with the Ravel Cord.
- Set the Stitch Dial to 2 and knit 66 rows with the main yarn.
- Push up the empty needles to B position.
- Turn up the hem placing the loops on the first row knitted with main yarn onto the needles as shown below.
(Refer to page 31).

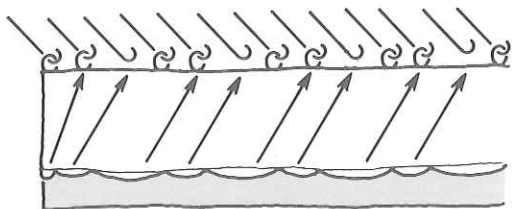

Back

(1) To knit welt

- Arrange 168 needles of both beds, (Knitter and Ribber) to B position for K1.P1. rib as instructed.
Swing Indicator 5
Half Pitch Lever P

- Stitch Dial at 0, cast on over the needles with main yarn.

- Row Counter 000

Stitch Dial 2–3

Knit 27 rows in ribbing, and have the Carriage at right side.

- Transfer all the ribber stitches onto the corresponding knitter needles using the Double Eye Transfer Tool. (168 stitches on the knitter.)

- Drop the Ribber to its lowest extent and exchange the ribber arm for the knitter arm.

Note: Mock rib can be applied in place of K1. P1. rib for welt, cuff and neckband.

(2) To knit straight up to the armhole

- Stitch Dial ⑤, knit 176 rows without shaping (Row Counter at 203) Carriage at the right side.

(3) To shape armhole

- Décrease 5 stitches at the beginning of next 2 rows, 3 stitches of next 2 rows, and 2 stitches of next 4 rows.
- Decrease 1 stitch at both ends of next and following alternate rows, 6 times in all till the Row Counter shows 223. (*)
- 132 stitches remain on the needles.
- Knit 80 rows without shaping. (Row Counter at 303) Carriage at right side.

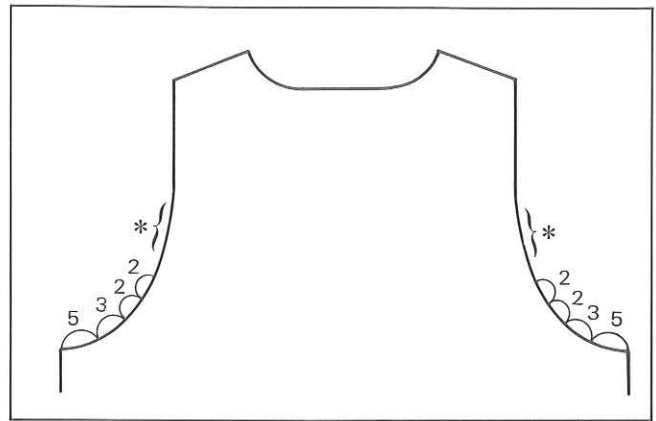

(4) To shape shoulder

- Decrease 4 stitches at the beginning of next 4 rows.

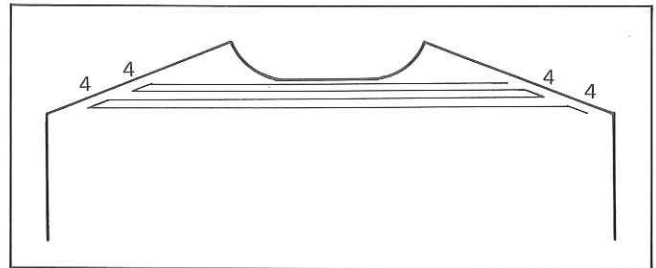

(5) To shape neck & right shoulder

- Using odd length of the main yarn, with the Transfer Tool cast off 42 stitches at the centre. (Cast off using the Transfer Tool – page 31.) Push back the empty needles to A position.
- Knit with the Ravel Cord the 36 stitches by hand and push them back to A position one by one. (Holding stitches with Ravel Cord – page 28.)

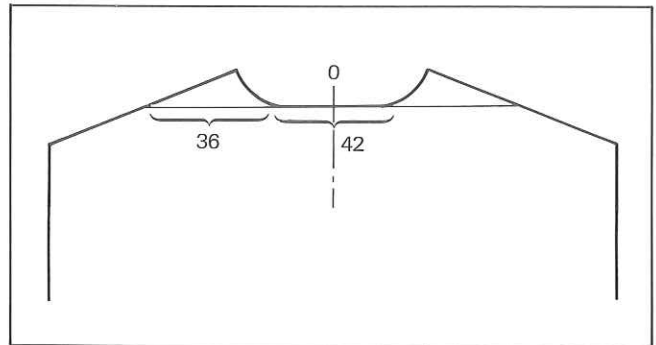

- Decrease 4 stitches at the beginning of next 3 rows,
- 3 stitches of next row (neck side),
- 4 stitches of next row (shoulder side),
- 3 stitches of next row (neck side),
- 4 stitches of next row (shoulder side).
- 3 stitches of next row (neck side).
- 4 stitches of next row ((shoulder side).
- Knit 1 row and cast off remaining 4 stitches. (Row Counter at 317).

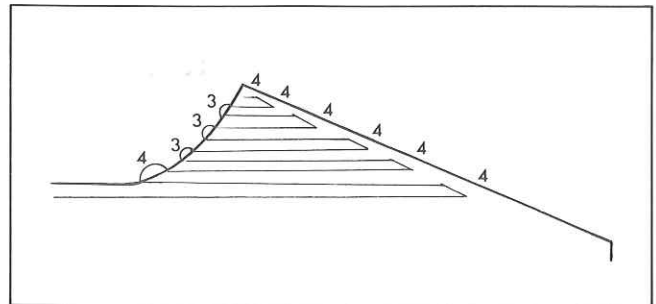

(6) To shape left section

- Bring the Carriage to the left side.
- Undo the Ravel Cord and replace the stitches into the hooks of the needles aligned in B position. (Refer to page 28.)
- Shape the left section as done for the right section.

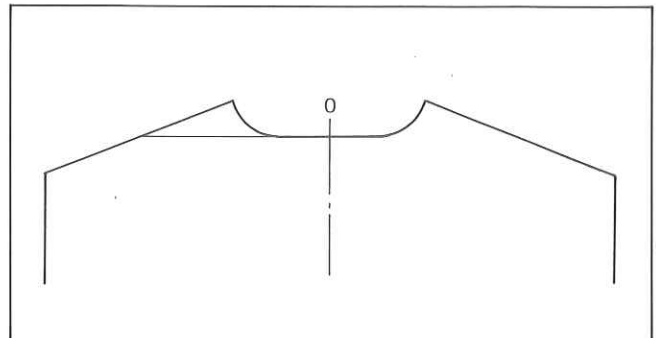

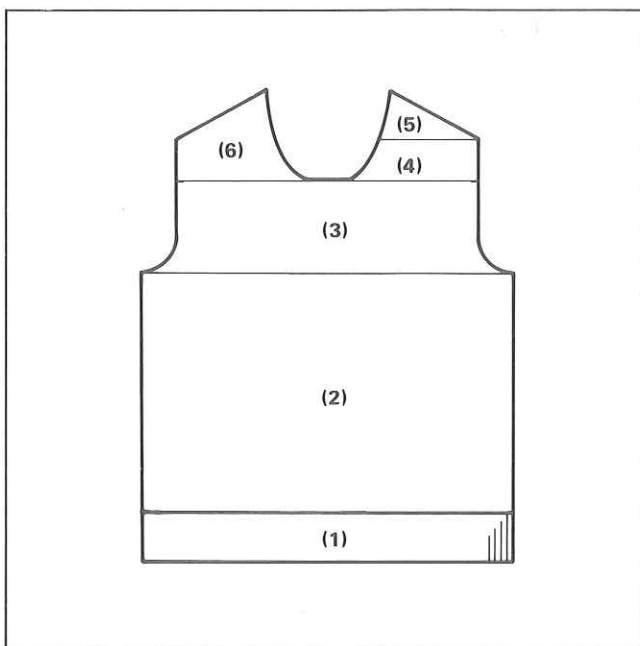

Front

(1)–(3) To knit up to the neckline

- Follow the instructions for the back till the Row Counter shows 223.
- Knit 34 rows without shaping Carriage at the right side. (Row Counter at 267)

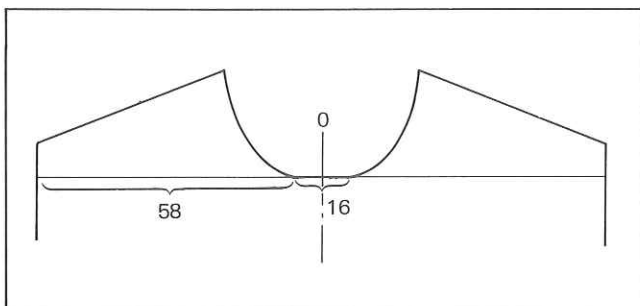

(4) To shape front neckline of right section

- Using the same yarn used for knitting, cast off 16 stitches at the centre section by hand. Push back the empty needles to A position.
- Knit with the Ravel Cord 58 stitches of the left section by hand and push them back to A position one by one.
- Knit 1 row.

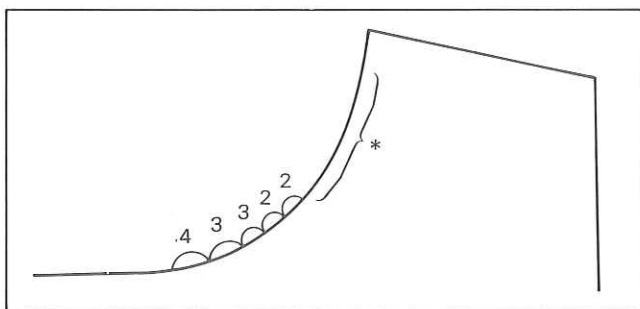

- Decrease 4 stitches at the beginning of the next row.
- Decrease 3 stitches at the beginning of the next and following alternate row.
- Decrease 2 stitches at the beginning of the next and every following alternate row, 2 times in all.
- Decrease 1 stitch at the beginning of the next and every following alternate row, 12 times in all. (*)
- Knit 1 row, Carriage at the right side. (Row Counter at 301)

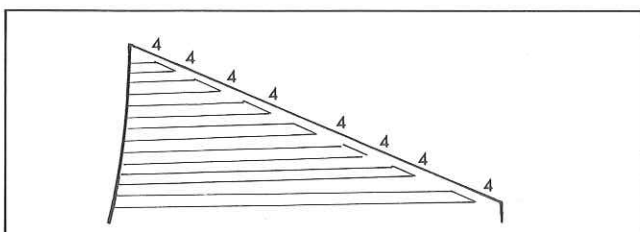

(5) To shape right shoulder

- Decrease 4 stitches at the beginning of next and following alternate rows 8 times in all. (Row Counter at 317)

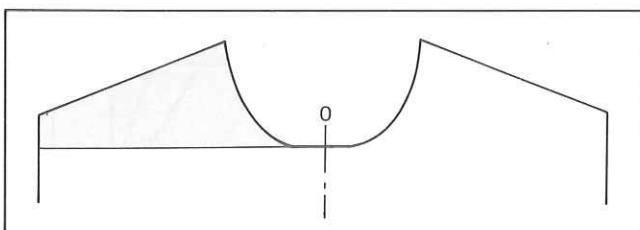

(6) To shape left section

- Bring the Carriage to the left side.
- Undo the Ravel Cord and replace the stitches into the hooks of the needles aligned in B position.
- Knit the left section as done for the right section.

Sleeves (both alike)

(1) To knit cuff

- Arrange 74 needles on both beds and knit in the same manner as done for the welt.

(2) To shape underarm

- Stitch Dial ⑤, increase 1 stitch at both ends of the next and every following 7th row, 28 times in all, until the Row Counter shows 224.
- 130 stitches remain on the Knitter.

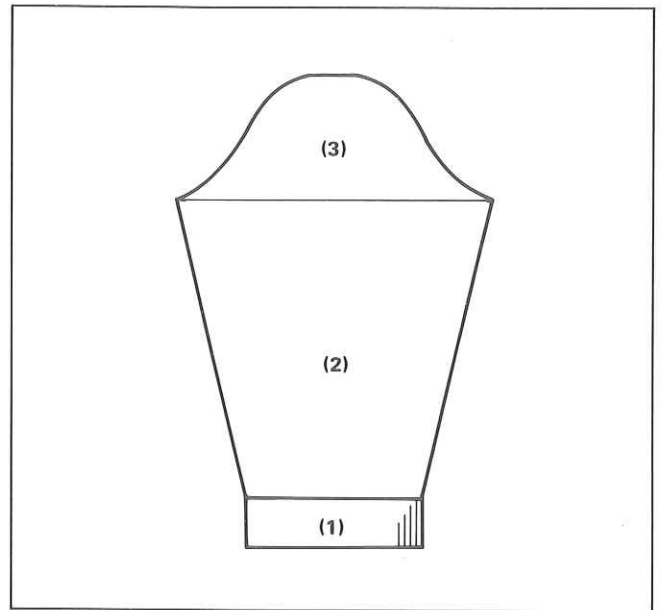

(3) To shape sleeve top

- Decrease 4 stitches at the beginning of the next 4 rows, 3 stitches of next 2 rows, and 2 stitches of next 10 rows.
- Decrease 1 stitch at both ends on the next row and every following alternate row, 18 times in all. (*)
- Knit 1 row.
- Decrease 2 stitches at the beginning of the next 4 rows.
- 3 stitches of the next 2 rows.
- 4 stitches of the next 2 rows.
- 5 stitches of the next 2 rows.
- Cast off the remaining 20 stitches. (Row Counter at 296)

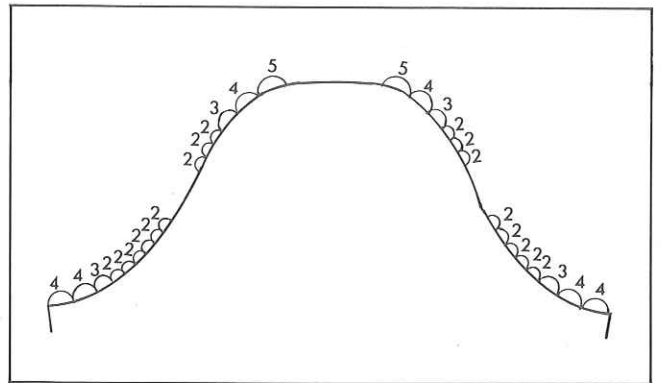

Neckband

Block and press each piece and join the right shoulder (refer to page 17), before knitting the neckband.

Arrange 168 needles on both beds for K1.P1. rib and knit 15 rows as for the welt.

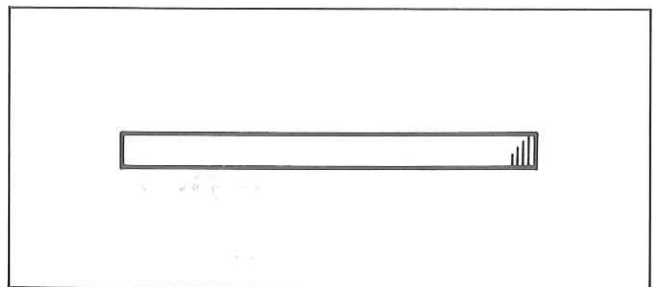

Making up

Follow the instructions on page 18 to join the neckband to the neck edge and make up.

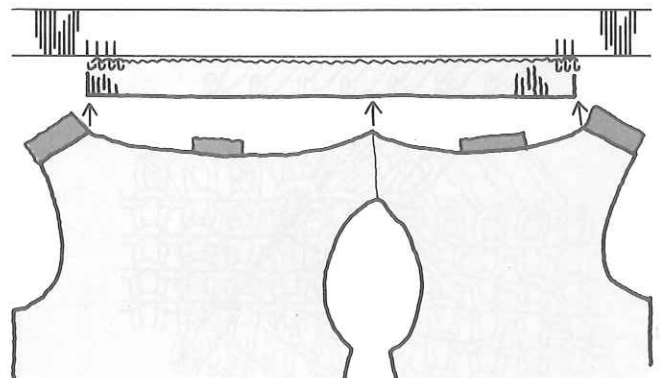

KNITTING TECHNIQUES

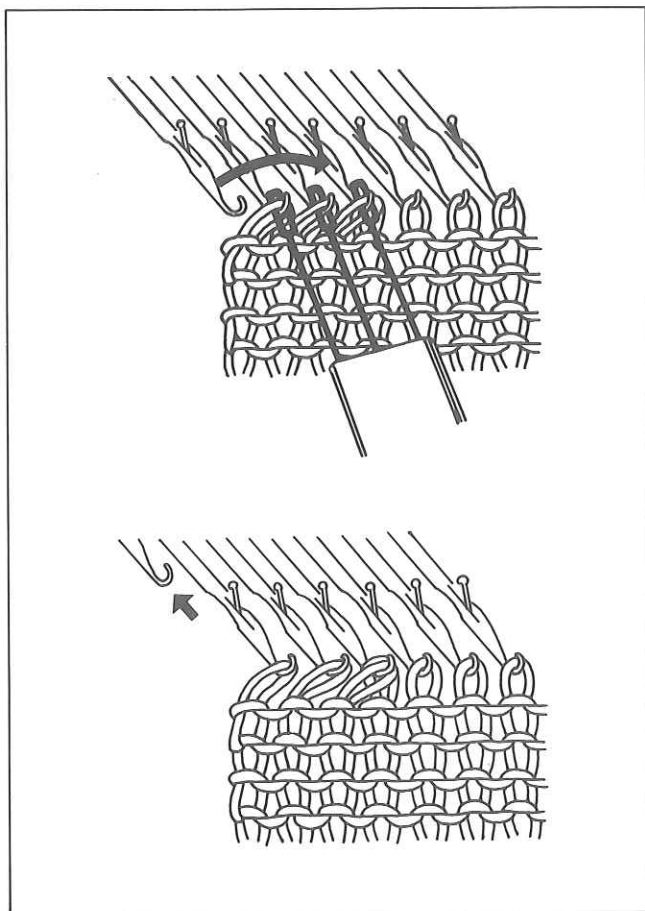

Fully fashioned decrease

(1) With the 3 x 1 tool, transfer the three end stitches one needle in.

(2) Push the end empty needle back to A position. Continue to knit.

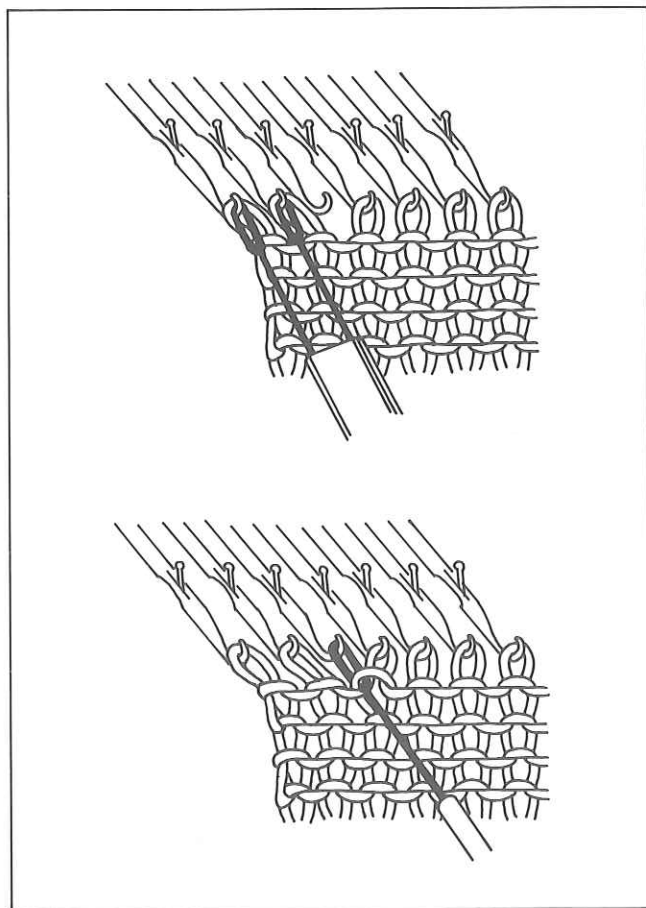

Fully fashioned increase

(1) Adjacent to the end stitch push an empty needle up into B position. With the 2 x 1 tool transfer the two end stitches one needle out.

(2) Pick up the loop below the third stitch and place it onto the empty needle as shown. Continue to knit.

PARTIAL KNITTING is a practical method for shaping a gentle slope, such as a shoulder, back of slacks and so on.

Partial knitting by decreasing stitches

(Main Carriage only)

Set the Russel Levers to the **I** position.

- (1) Push up the needles to be decreased, to D position, on the opposite side of the Carriage.

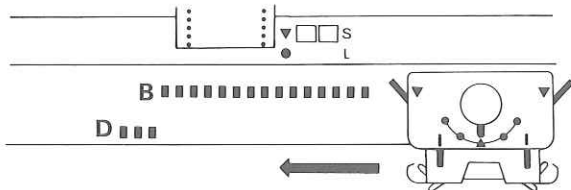

- (2) Knit 1 row. (The needles in B position knit the yarn. The needles in D position remain inactive and the yarn passes over them.)
- (3) To prevent a hole from being formed in the fabric, pass the yarn under the first inside needle in D position and over the other needles. (If partial knitting is required on both sides, apply step (1) before knitting the next row.)
- (4) Knit 1 row by moving the Carriage back. This completes the first operation of partial knitting.
- (5) Repeat steps (1)–(4).

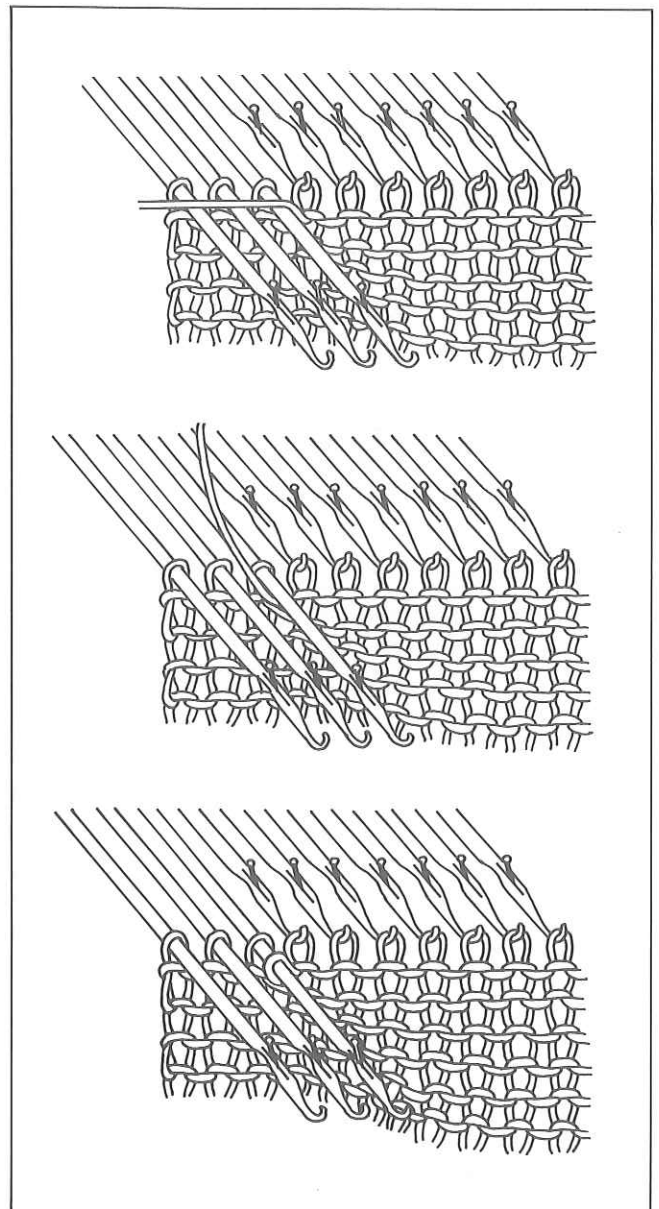

At the completion of partial knitting, work as follows to knit continuously.

A. In case of stockinet

Push the needles in D position back to C position. Needles in C position will knit and align in B position.

B. In case of pattern knitting

With a Transfer Tool, push the needles in D position towards A position until the stitches move onto the Transfer Tool, then place the stitches in the needle hooks.

Align the needles correctly in B position.

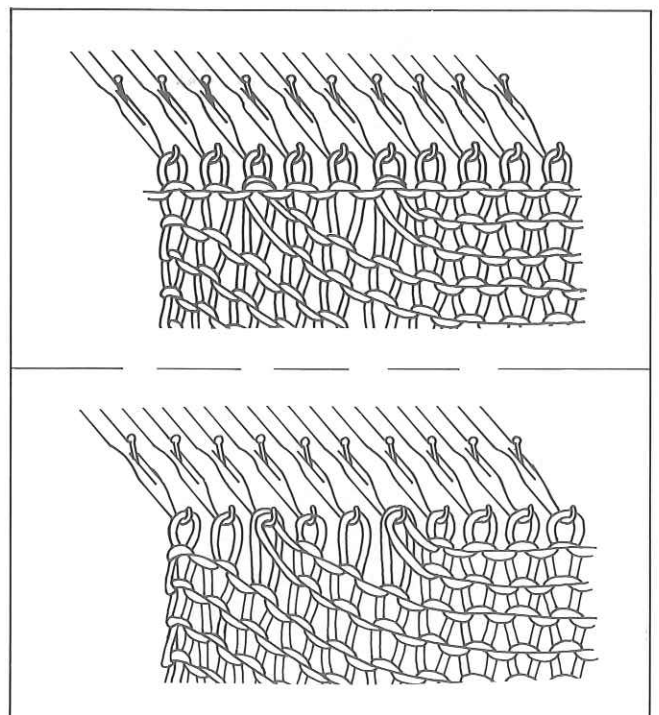

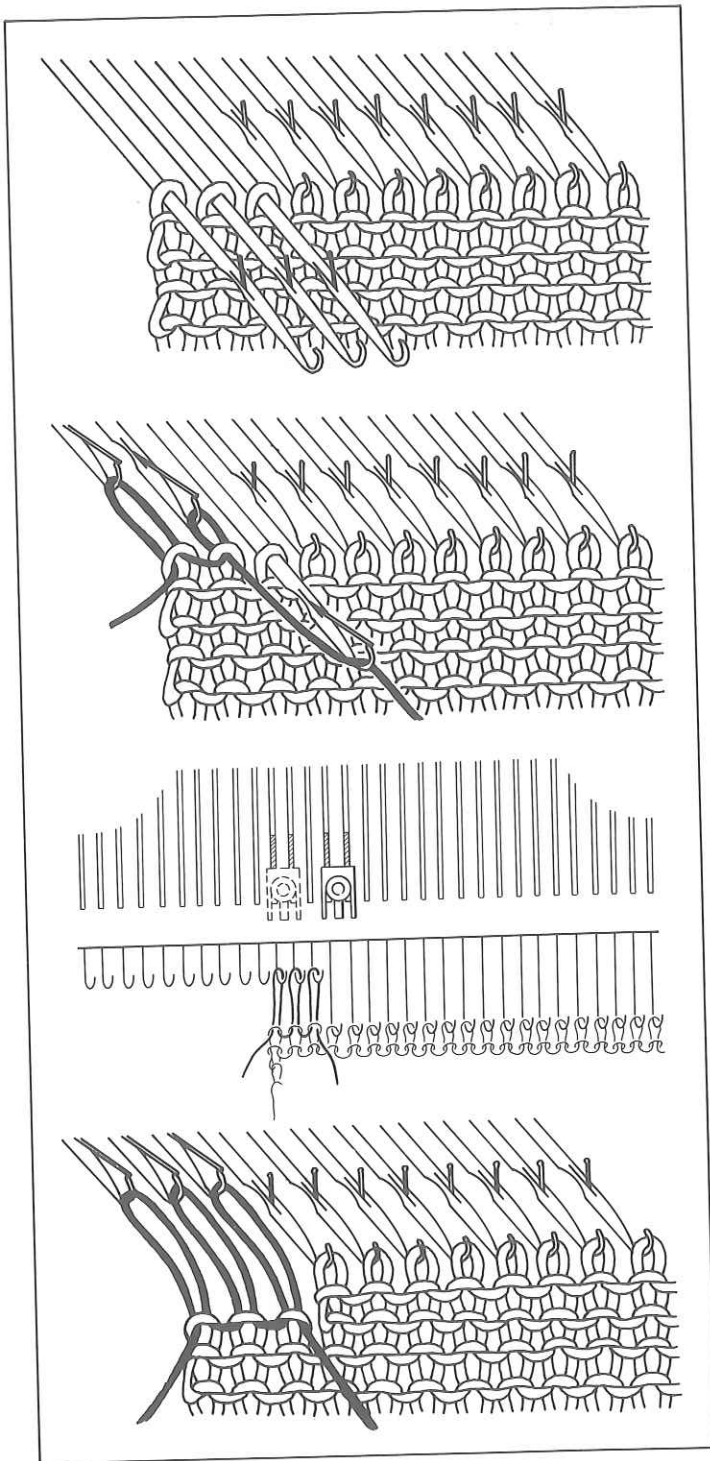

Partial knitting by decreasing stitches

(Lace Carriage only)

- (1) On the side without yarn end, push up the needles required for decrease to D position.
- (2) Lay the Ravel Cord into the open needle hooks, and knit the needles back one by one from D to A position by hand.
- (3) Replace the Edge Pin at the two end needles in B position.
- (4) Knit two rows.
- (5) Repeat steps (1) through (4) as many times as is required.

When the partial knitting is completed, hang the weights and replace the stitches into needle hooks by pulling up the Ravel Cord.

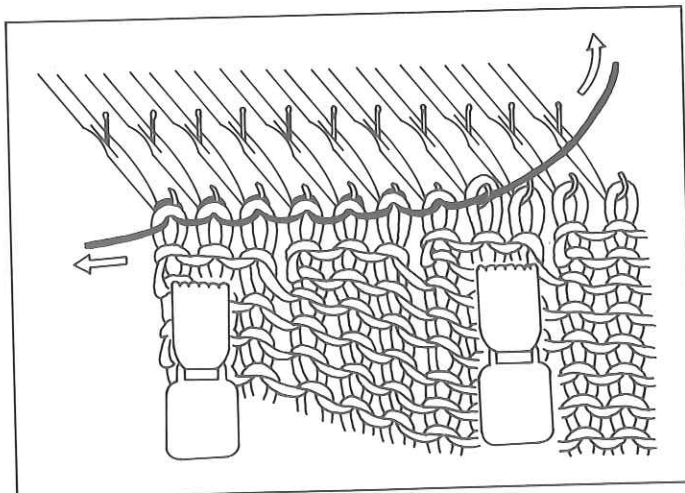

If partial knitting is required at both sides apply steps (1) to (3) and (4*) Knit 1 row.

Repeat steps (1) to (4*) as many times as required.

Partial knitting by increasing stitches

(Main Carriage only)

Set the Russel Levers to the I position.

- (1) On the side opposite the Carriage, push up the needles for the width to be shaped by partial knitting to D position.
- (2) Knit 1 row.
(The needles in B position knit the yarn. The needles in D position remain inactive and the yarn passes over them.)
- (3) Pass the yarn under the first inside needle in D position and over the other needles.
(If partial knitting is required on both sides, apply step (1) before knitting the next row.)
- (4) Knit 1 row by moving the Carriage back.
- (5) Before knitting the next row, work on the side opposite the Carriage as follows.

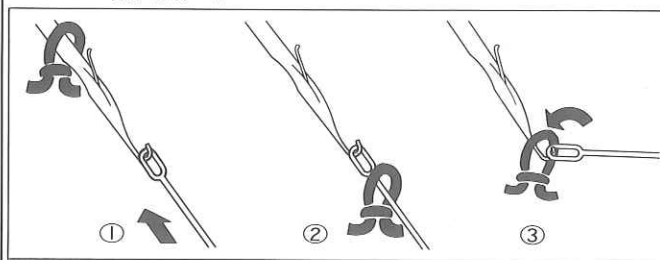
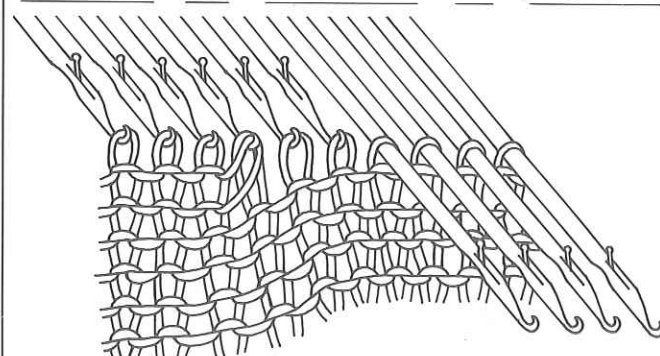
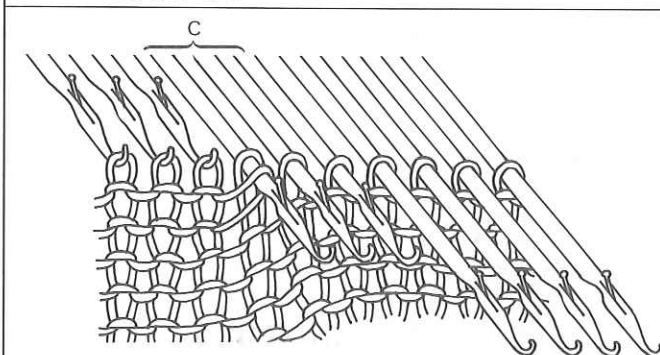
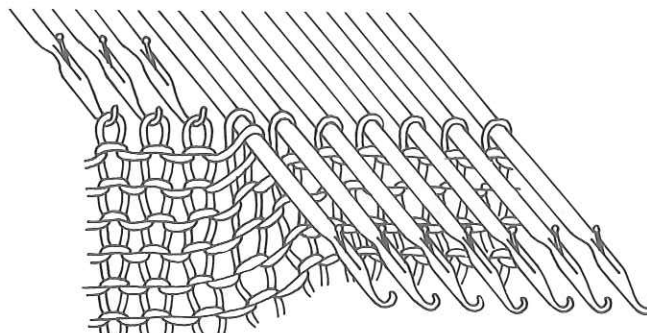
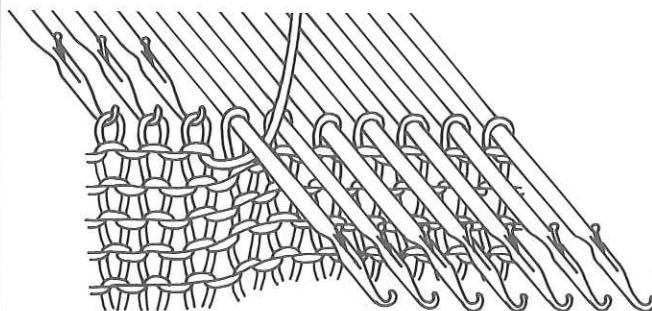
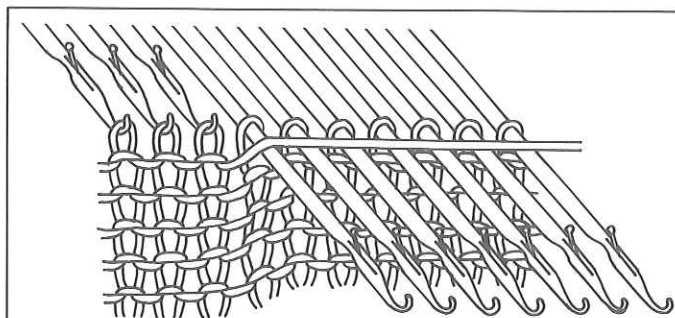

A. In case of stockinet knitting

Push the needles to be increased back to C position.

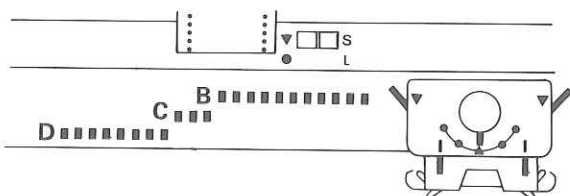

B. In case of pattern knitting

With a Transfer Tool, push the needles to be decreased towards A position till their stitches move onto the Transfer Tool. Then place the stitches in the needle hooks.

Align the needles correctly in B position.
(See the illustration.)

- (6) Repeat steps (2)–(5).

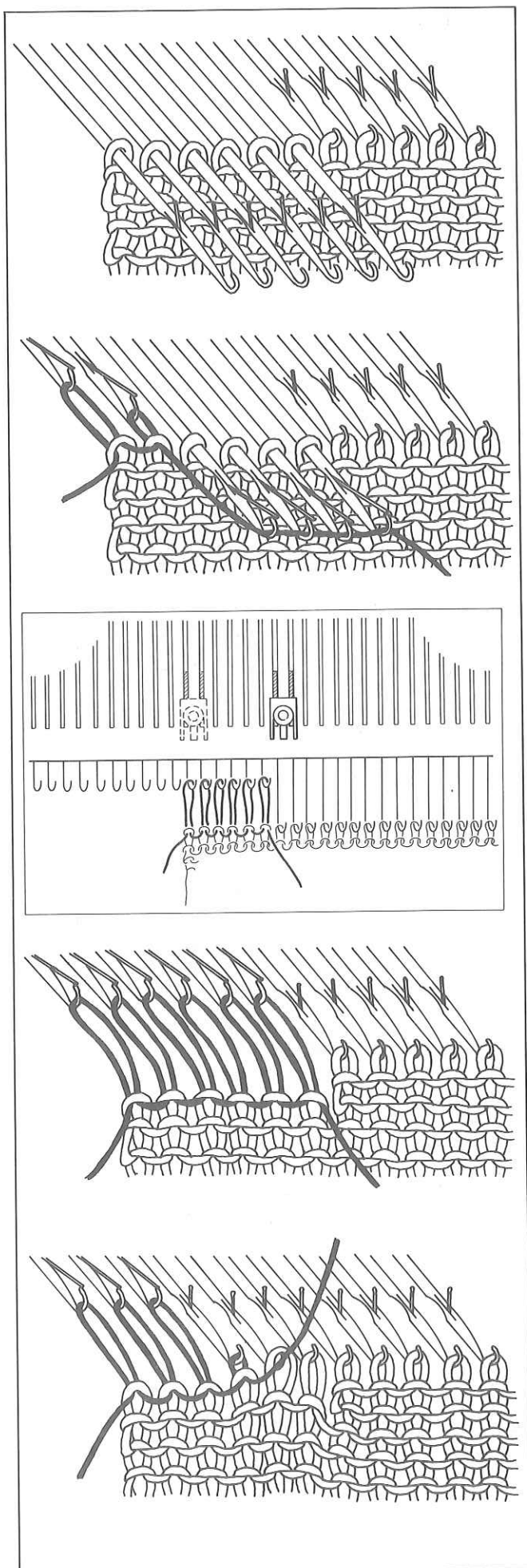

Partial knitting by increasing stitches

(Lace Carriage only)

(1) On the side without yarn end, push up the needles required for shaping by partial knitting to D position.

(2) Lay the Ravel Cord into the open needle hooks and knit the needles back one by one from D to A position by hand.

(3) Replace the Edge Pin at the end two needles in B position.

(4) Knit two rows.

If partial knitting is required on both sides apply steps (1) to (3), but at step (4) knit 1 row only.

(5) On the side without yarn end, push up the needles required for increase to B position, and unravel the Ravel Cord to replace the stitches into the needle hooks.

(6) Replace the Edge Pin at the end two needles in B position.

* Repeat steps (3) through (5) as many times as required for partial knitting.

When knitting separately as for the neckline, apply these methods to hold the stitches for latter work.

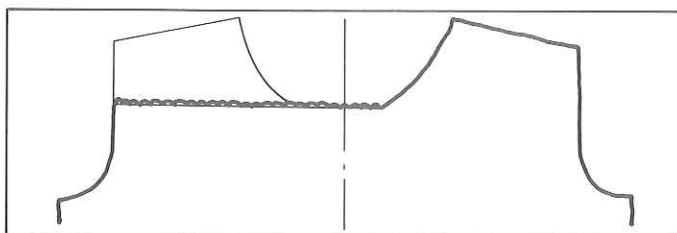

Holding stitches in D position

(Main Carriage only)

(1) Push up the needles for the section to be held, to D position.

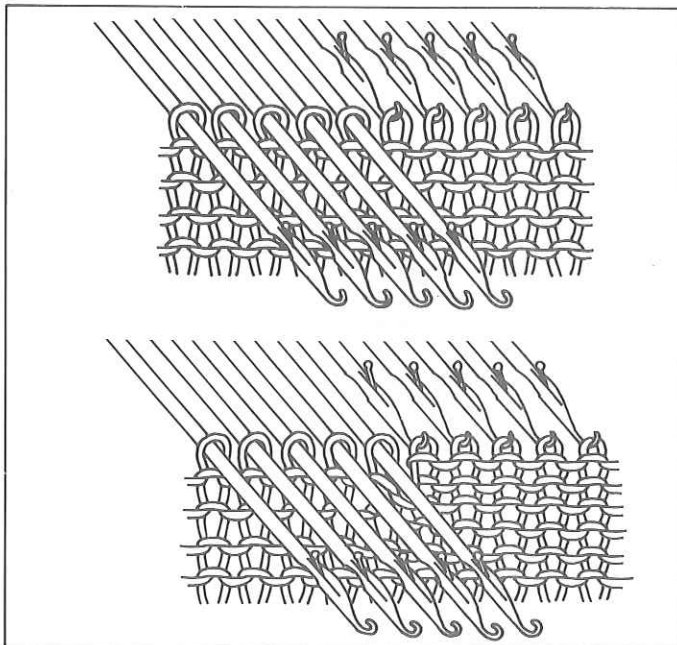

(2) Set the Russel Levers to the I position and continue to knit for the needles in B position.

Holding stitches with Ravel Cord

(1) Push up the needles for the section to be held, to D position, and lay the Ravel Cord across the hooks. Starting from the end needle, manually knit the needles one by one to A position.

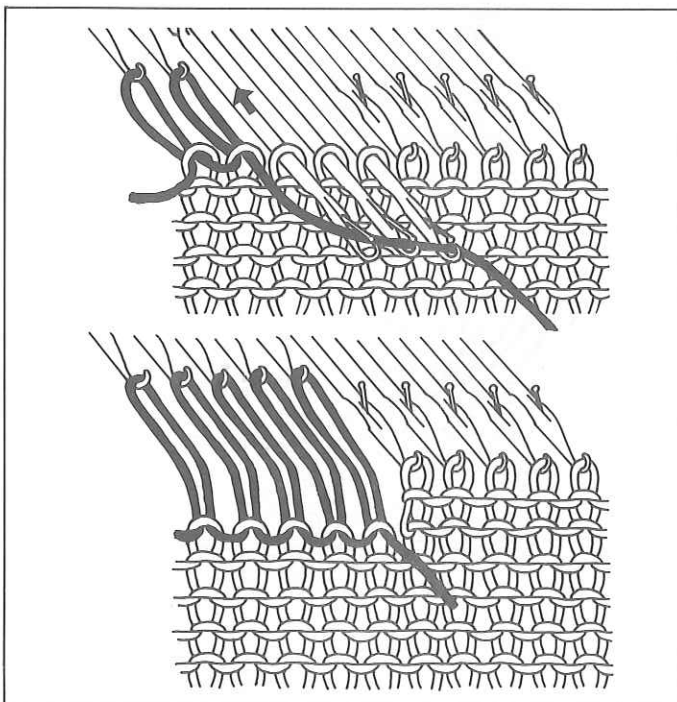

(2) Continue to knit over the needles in B position.

* To replace the stitches, hold the Ravel Cord firmly at both ends and pull outwards bringing the needles to B position and replace the stitches in the needle hooks.

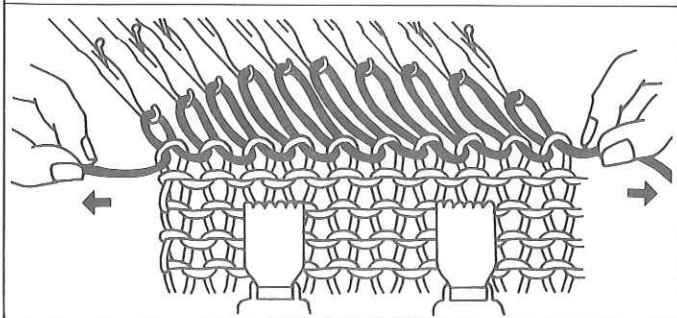

Note: Hang the Claw Weights.

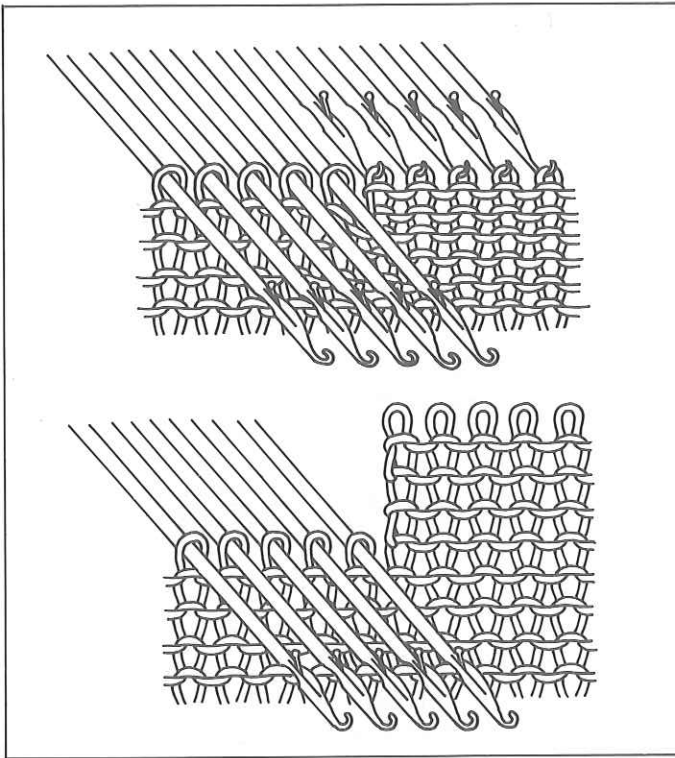

Holding stitches on waste knitting

(Main Carriage only)

Set the Cam Lever to STOCKINET (0) and the Russel Levers to the I position.

- (1) Leaving the needles in B position for the section to be held, push the remaining needles into D position.
- (2) Knit several rows of waste knitting over the needles in B position. Then remove the section from the machine.

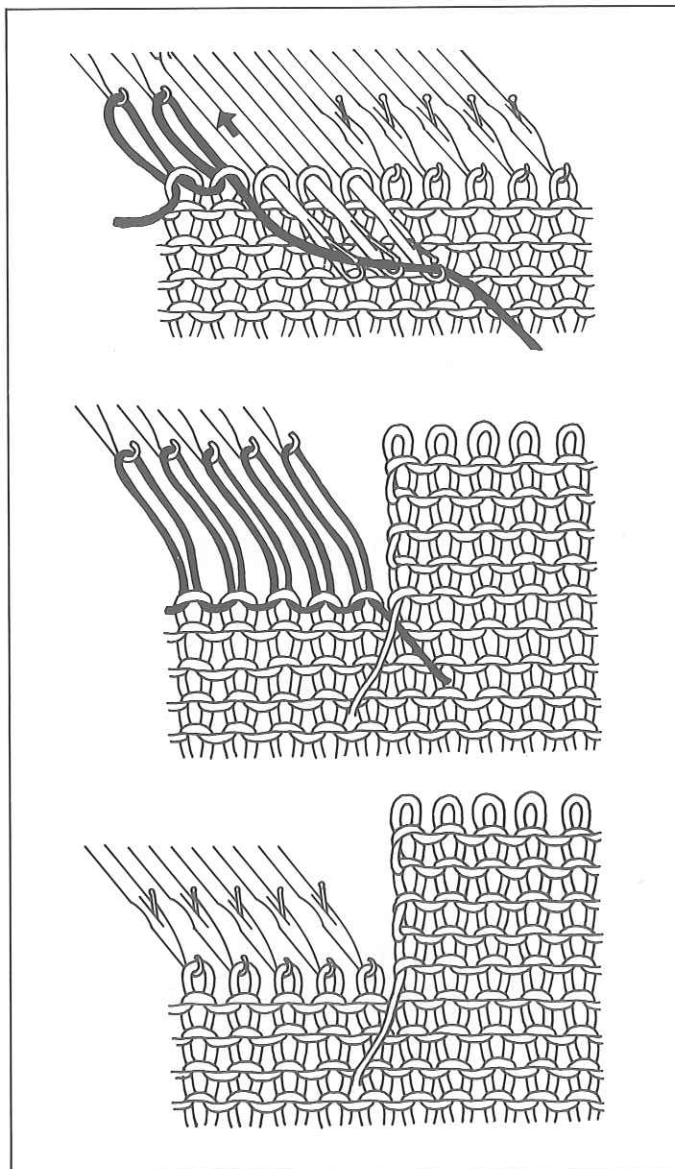

Holding stitches on waste knitting

(Lace Carriage only)

- (1) Except for the stitches to be held on waste knitting, push up the needles to D position.
- (2) Lay the Ravel Cord across the open hooks of the needles in D position and by hand knit the needles back one by one to A position.
- (3) Set the Side Levers to ● mark, stop the Punch Card, and knit the several rows of waste knitting over the needles in B position. Then remove the section from the machine.

To continue knitting, reset the Side Levers and Stop Knob at the original position, unravel the Ravel Cord to replace the stitches in the needle hooks (refer to page 28).

When re-knitting the stitches held on waste knitting, pick up the stitches on the last row of the main knitting and place them onto the corresponding needles.

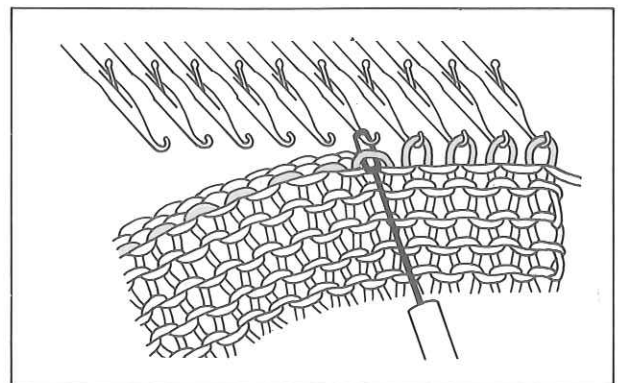

Cast off with Tappet Tool

This is used for closing the stitches when main knitting is completed.

- (1) Knit the cast off row with the Main Carriage, setting the Stitch Dial 3–4 numbers higher, then push the needles to D position. On the side opposite the Carriage, hook the first stitch with the Tappet Tool and push back the needle to A position. The stitch is transferred onto the Tappet Tool.

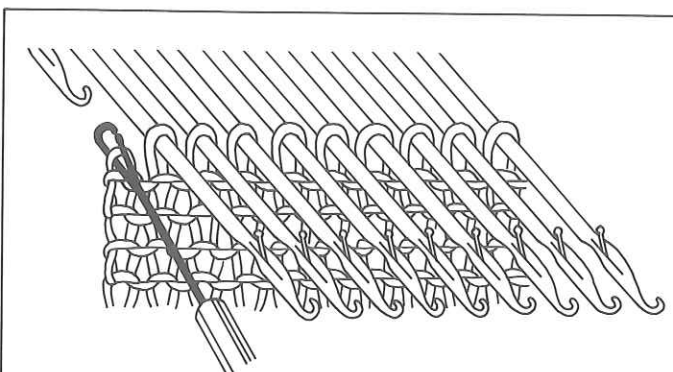

- (2) Place the stitch behind the latch of the Tool.

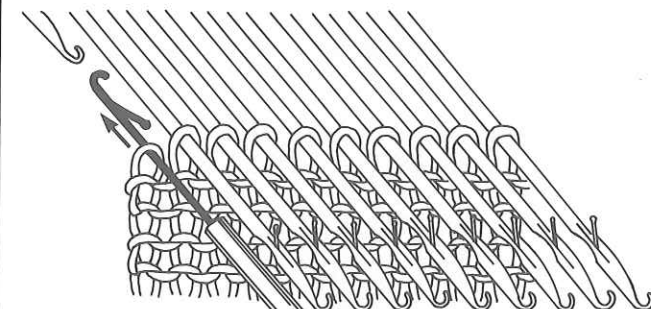

- (3) Hook the second stitch, push the needle back as indicated by the arrow but pull the Tappet Tool in the opposite direction.

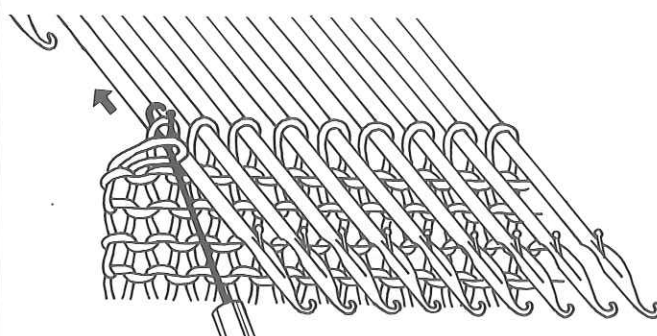

The first stitch will have slipped off the tool.

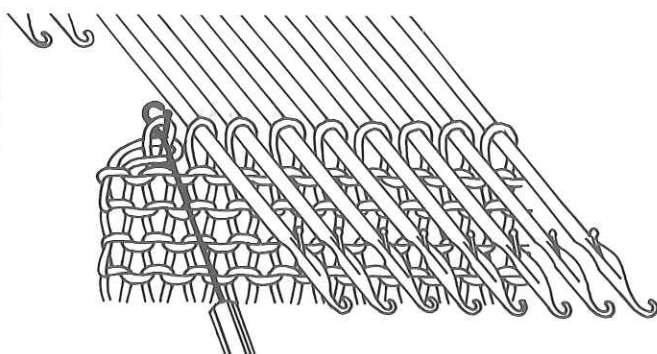

- (4) Repeat steps (2)–(3).

Cast off the last stitch by guiding the yarn end through the stitch with the Tappet Tool as shown.

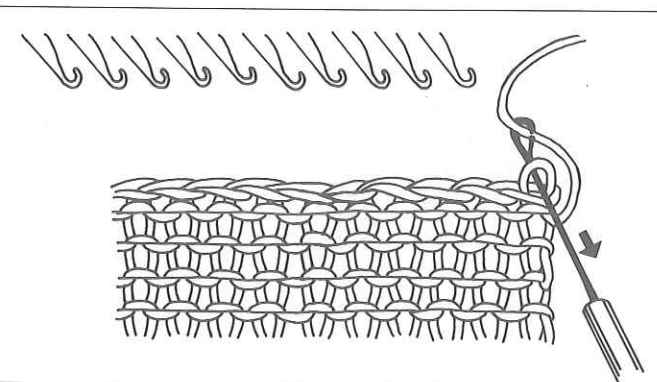

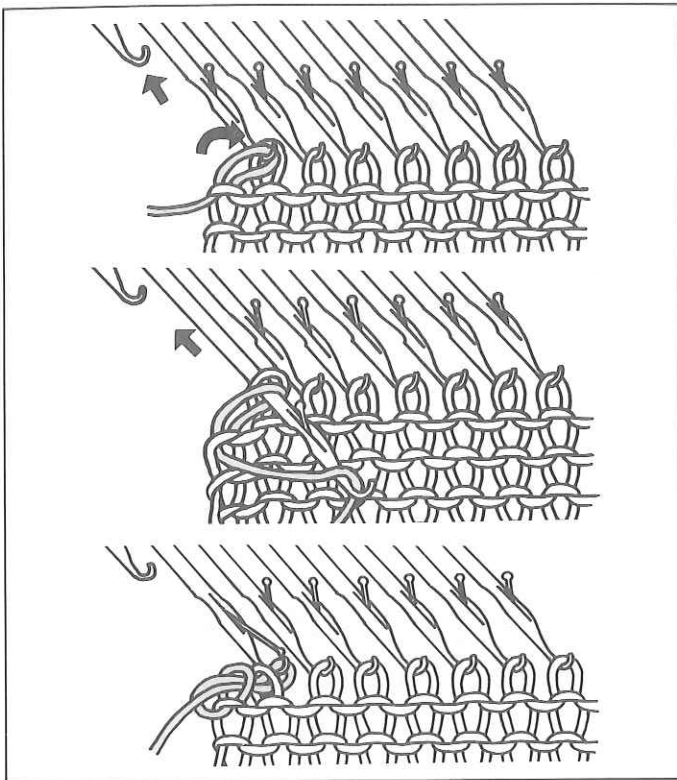

Cast off with Transfer Tool

- (1) Transfer the first stitch onto the second needle.
- (2) Push the second needle to D position to have both stitches behind the latch, and lay the yarn inside the needle hook.
- (3) Push the needle back towards A position.
- (4) Repeat (1)–(3).

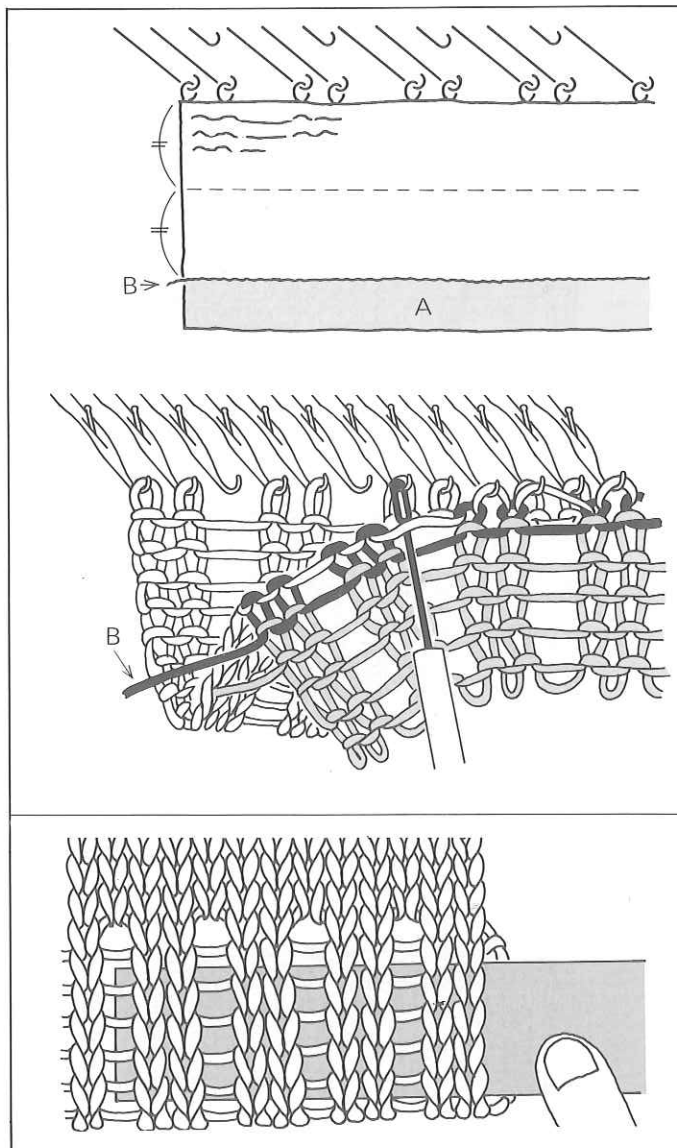

Mock rib

- (1) Push up the required number of needles to B position and push every third needle back to A position.
- (2) Cast on and knit several rows of waste knitting "A", then knit one row with the Ravel Cord "B".
- (3) Set the Stitch Dial 3 numbers lower than the original number and knit twice the depth of the hem.
- (4) Return the needles that were pushed back to A position to B position. Pick up the sinker loops from the first row of the main knitting and place them onto the empty needles in B position.
- (5) Reset the Stitch Dial to the original number and continue to knit.

* If the Ravel Cord is pulled out, the waste knitting comes off.

When ironing, insert a ruler-like object into the side opening of the ribbed knitting and stretch the fabric vertically.

Hemming

- (1) Cast on and knit several rows of waste knitting "A" then knit one row with the Ravel Cord "B".
- (2) With the main yarn, knit twice the depth of the hem.
- (3) Pick up the sinker loops from the first row of the main knitting and place them onto the corresponding needles.
- (4) With the Stitch Dial set 2 numbers higher, knit one row.
- (5) Set the Stitch Dial to the original number and continue to knit.

* If the Ravel Cord is pulled out, the waste knitting comes off.

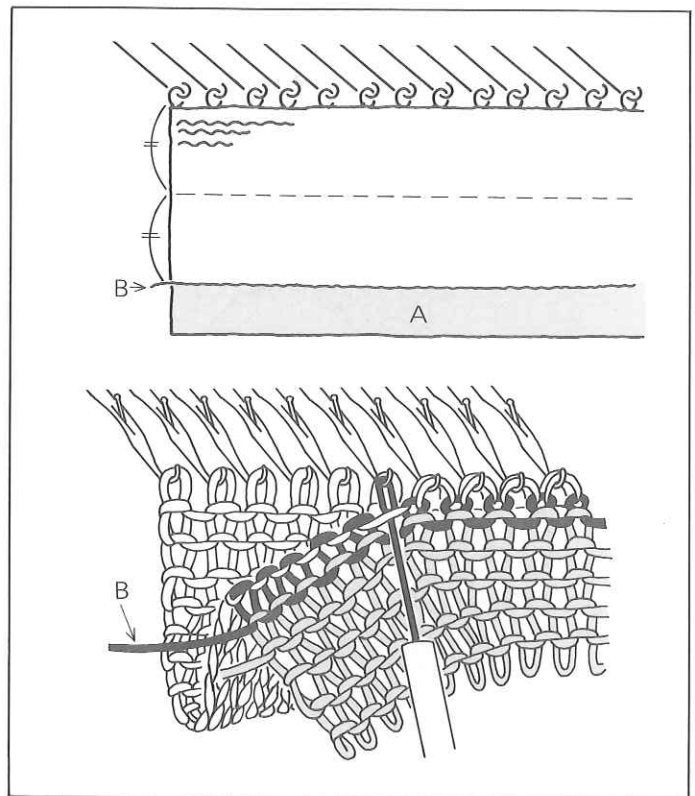

PICOT EYELETS

At the folding row, transfer every other stitch onto its adjacent needle.

Note: Align the empty needles in B position, and continue to knit.

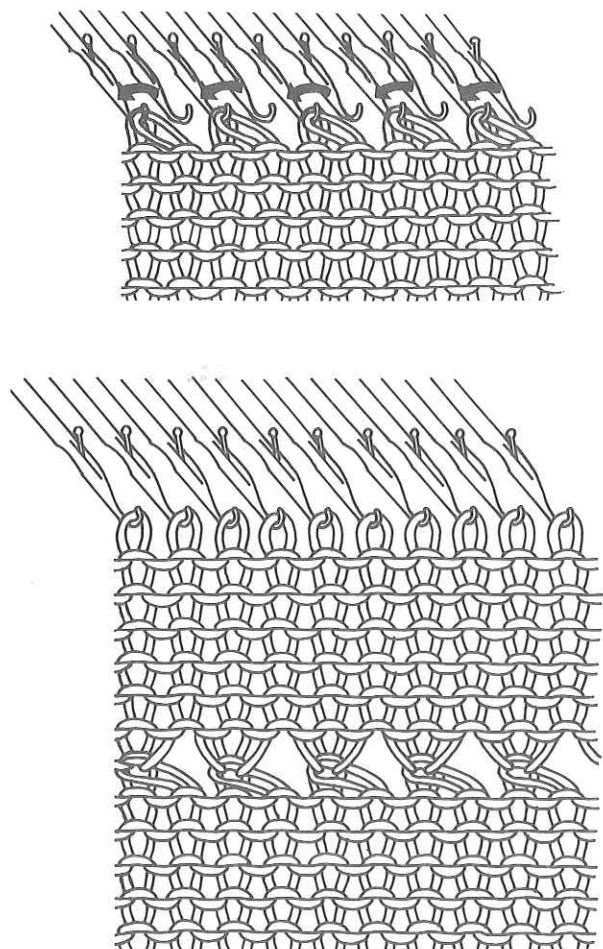
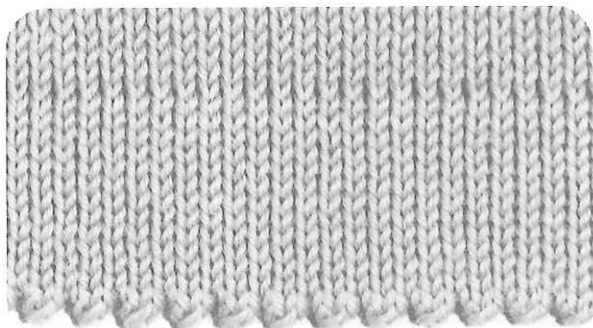

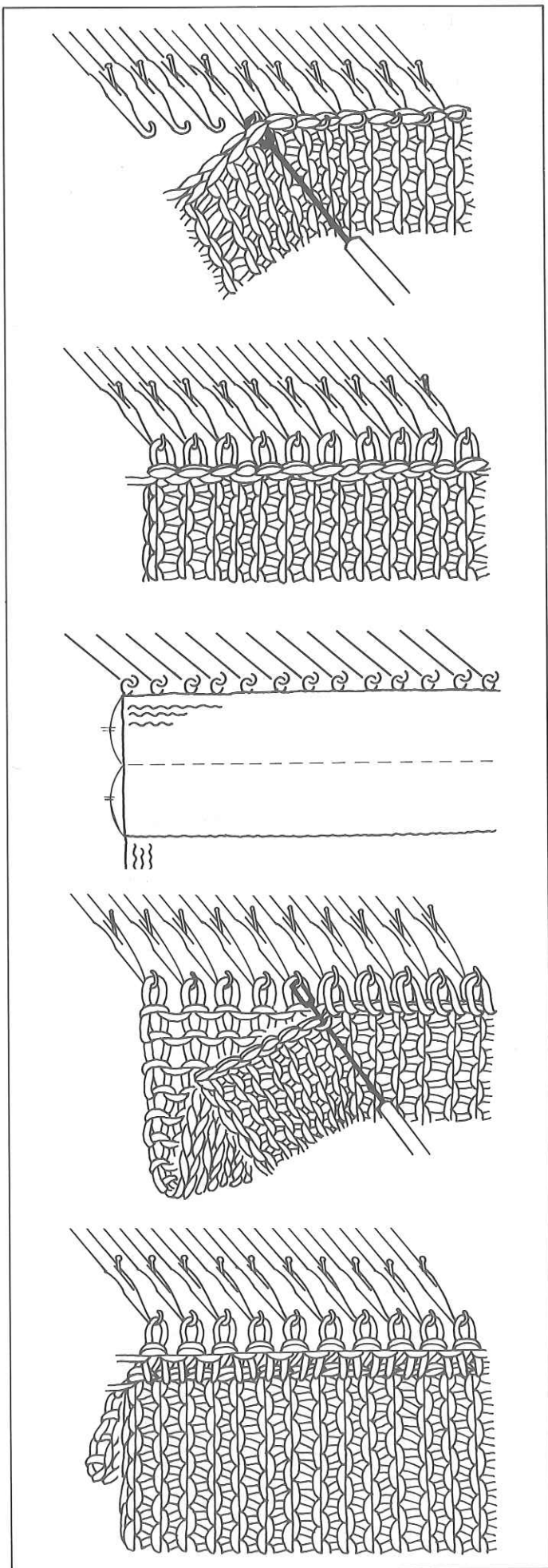

Trimming

Applicable to neckband, border etc.

- (1) With the wrong side facing you, place the stitches of a side edge onto the needles omitting a stitch at appropriate intervals.
- (2) With the main yarn, knit 1 row in stockinet with the Stitch Dial 1 number lower than that used for stockinet.
- (3) Re-set the Stitch Dial to the original number and knit twice the depth of the hem.
- (4) Pick up the sinker loops on the first row and place them onto the needles.
- (5) With the Stitch Dial set 2 numbers higher, knit 1 row.
- (6) Cast off using a Transfer Tool. (Refer to page 31.)

Buttonhole

- (1) Transfer 2 stitches onto their adjacent needles respectively.
- (2) Knit 1 row and remove the hooked yarn from the right side needle.
- (3) Knit 1 row. Pick up the yarn crossing above and place it onto the needle.
- (4) Continue to knit up to the next buttonhole.

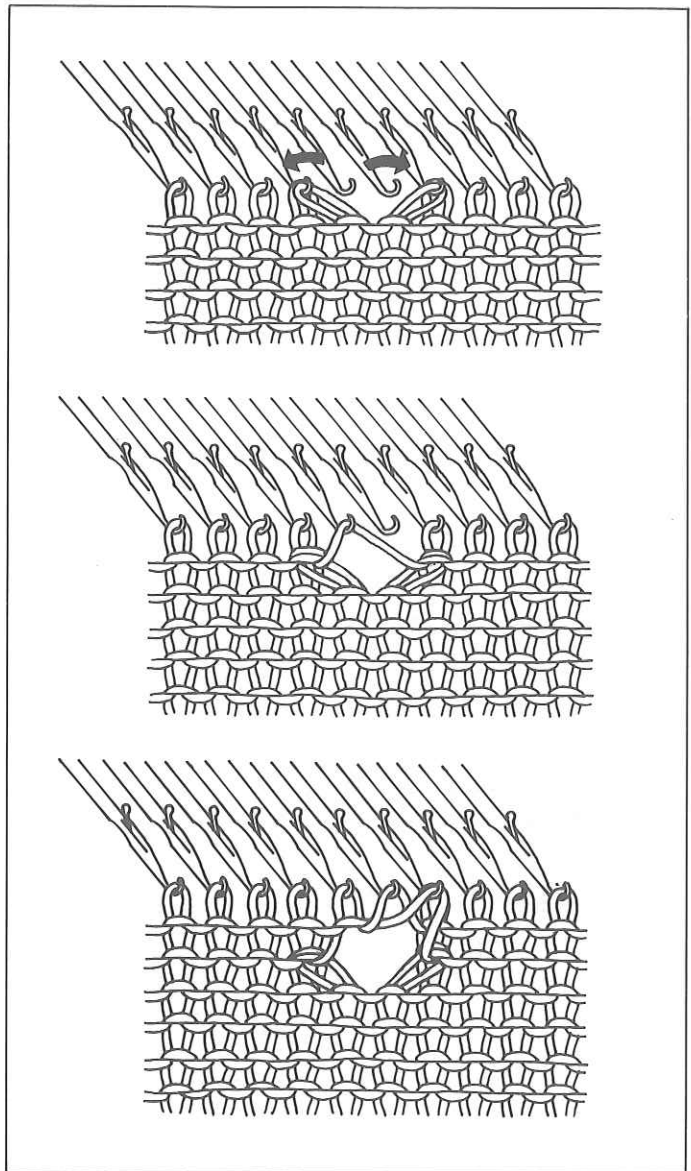

When making buttonholes on a double border, adjust the number of rows or stitches in between the inside buttonholes and outside buttonholes so that they correspond when the border is folded.

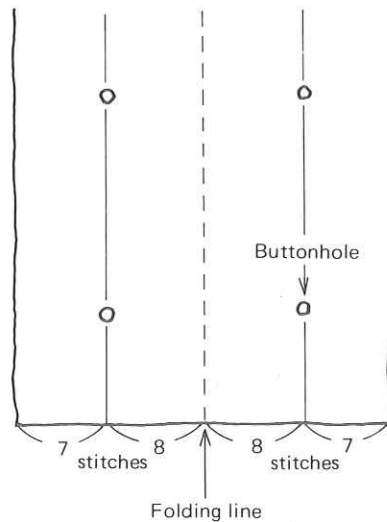
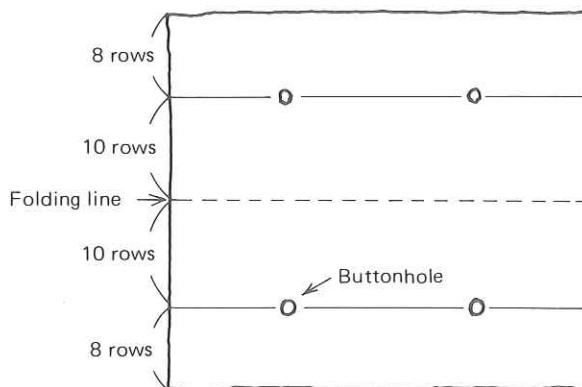

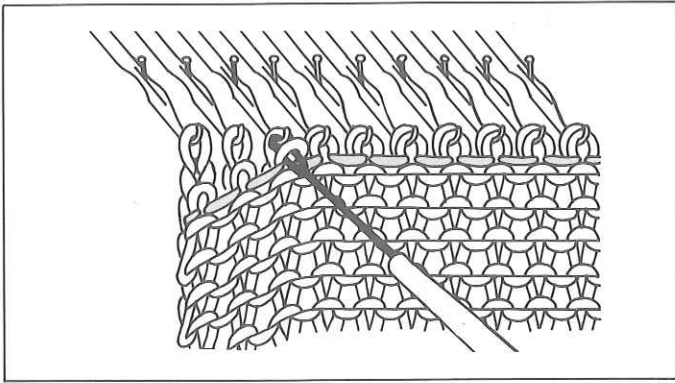

Joining on the machine

This is used for joining shoulders, joining a waistband to the waist edge, or joining a neckband to the neck edge, etc.

Pick up the stitches from the fabrics to be joined with the right side facing each other, and place them onto the same needles.

Knit 1 row with the Main Carriage, and cast off using the Automatic Linker or a Tappet Tool (refer to page 30).

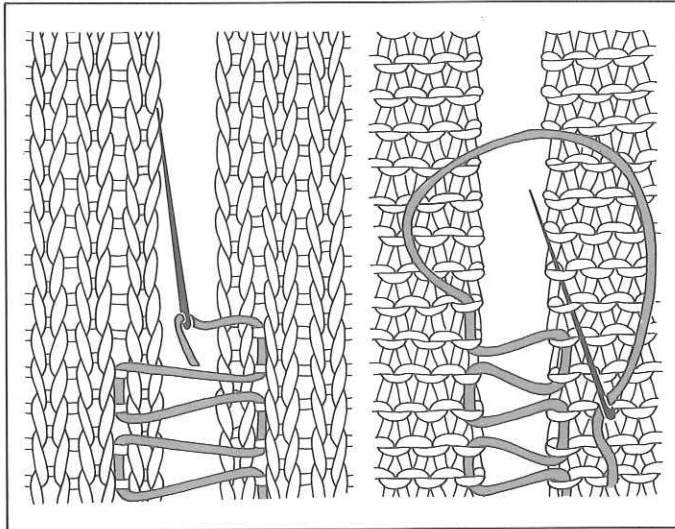

Blind stitch

This is used for joining side seams.

With the right side of both fabrics facing you, pick up two sinker loops together between the last two stitches from the side edges alternately, as illustrated.

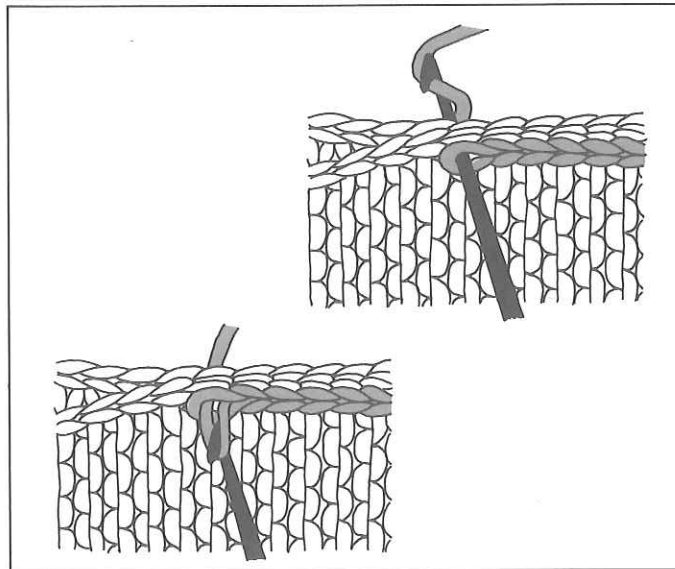

Slip stitch

This is used for setting in the sleeves or joining side seams.

Place the fabrics to be joined with the right side facing each other. Insert the Crochet Hook into the edge stitches and catch the yarn as shown.

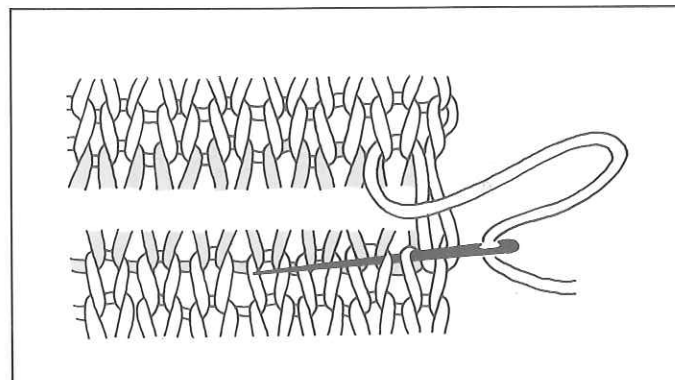

Grafting

This is used for joining two open stitches, where ridges formed by seaming should be soft to the touch.

Align both fabrics as shown and thread the knitting yarn through the stitches with the Tapestry Needle.

K1. P1. rib

With waste yarn, cast on, and knit several rows.

With the Ravel Cord, knit 1 row.

Using main yarn, knit the number of rows required for the ribbed welt.

(1) Push every alternate needle up into D position. These stitches are to be reformed into purl stitches. Pull the first needle back from D to A position, push the empty needle back into B position. Drop the stitch down to the Ravel Cord.

(2) From the rear hook the bar of the first stitch knitted in main into the tappet tool, and allow the bar to slide behind the latch. Twist the tappet tool to the right to form a loop.

(3) Working from the front, catch the bar of the yarn crossing above into the hook of the Tappet Tool, pull the tool backwards through the loop (stitch) to form a purl stitch. Continue in this manner until all the bars have been latched up.

(4) Place the last stitch back onto the empty needle.

(5) Repeat this procedure over the remaining stitches held on the needles in D position.

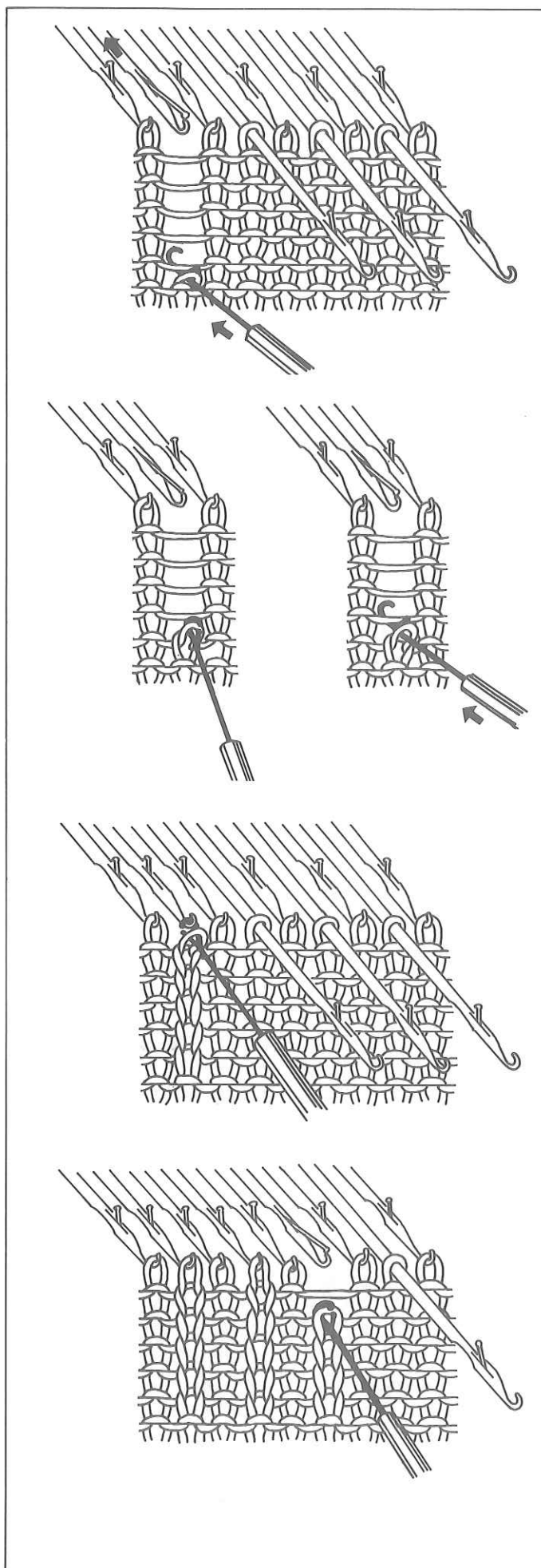

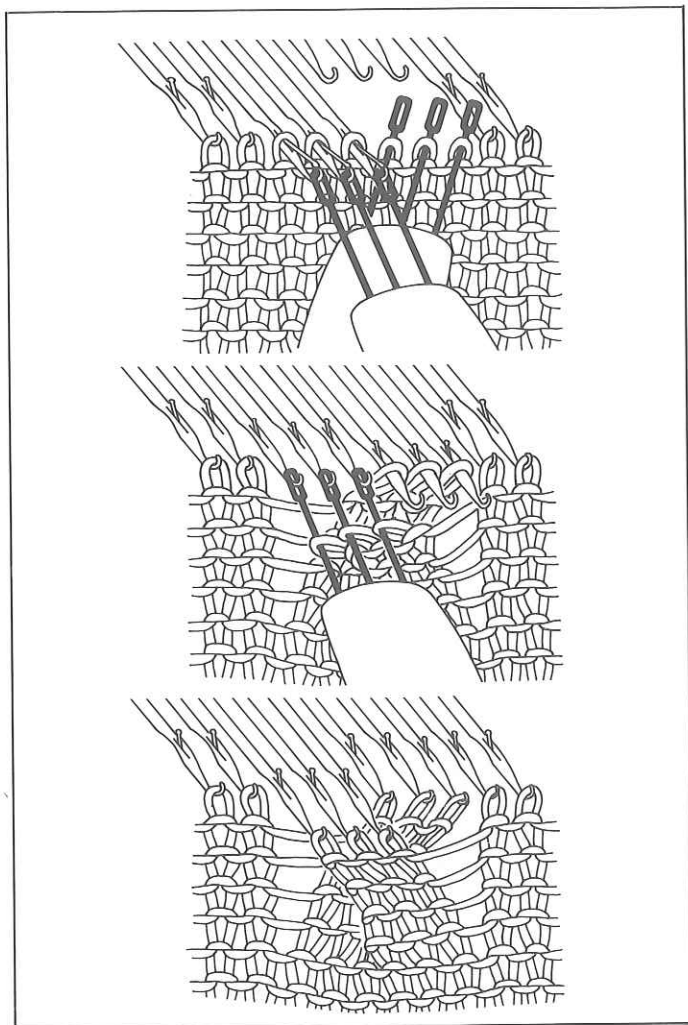

Cable stitch

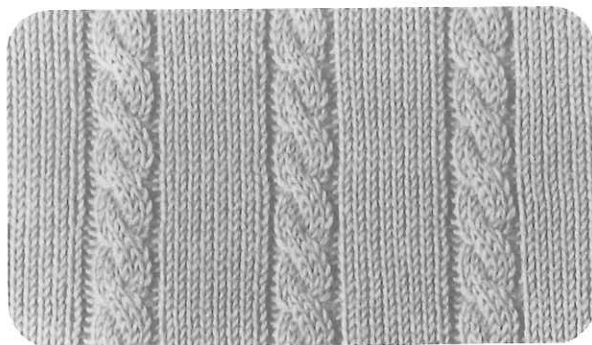

- (1) Using two treble transfer tools, take three stitches off the needles onto each tool.
- (2) Cross and transfer the three stitches at the right onto 3 empty needles at the left, transfer the remaining three stitches to the empty needles at the right.
- (3) Push these 6 needles up into D position, knit required number of rows.
- (4) Repeat the above procedure.

After three or four patterns have been worked, on either side of the cable drop a stitch down to the beginning of the pattern, insert the Tappet Tool into the stitch and latch up purl-ways.

(Refer to Page 36)

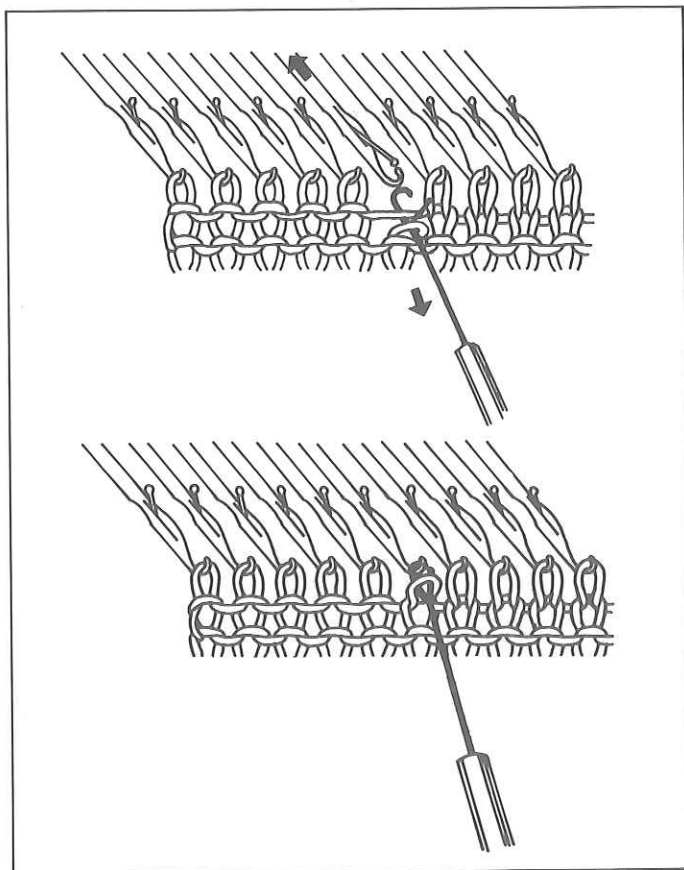

Garter stitch

Set the Stitch Dial to one number lower than that used for stockinet.

- (1) Knit 2 rows.
- (2) Open the latches of all needles and purl all the stitches on the last row using Tappet Tool.
- (3) Repeat these steps.

Cord knitting

- (1) Place the Carriage on the right side of the Needle Bed.
Depending upon the thickness of the cord, bring 3–5 needles to D position.
Cast on the stitches by the winding method as illustrated.
- (2) Set the machine as follows.

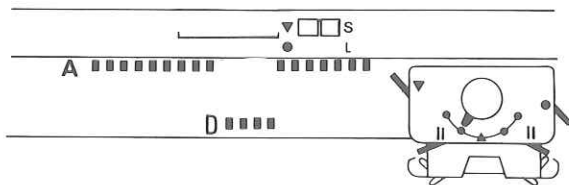

- (3) Move the Carriage back and forth knitting one row, holding the knitting down by hand.
- (4) Continue knitting, pulling the cord down lightly by hand, until the desired length has been achieved.

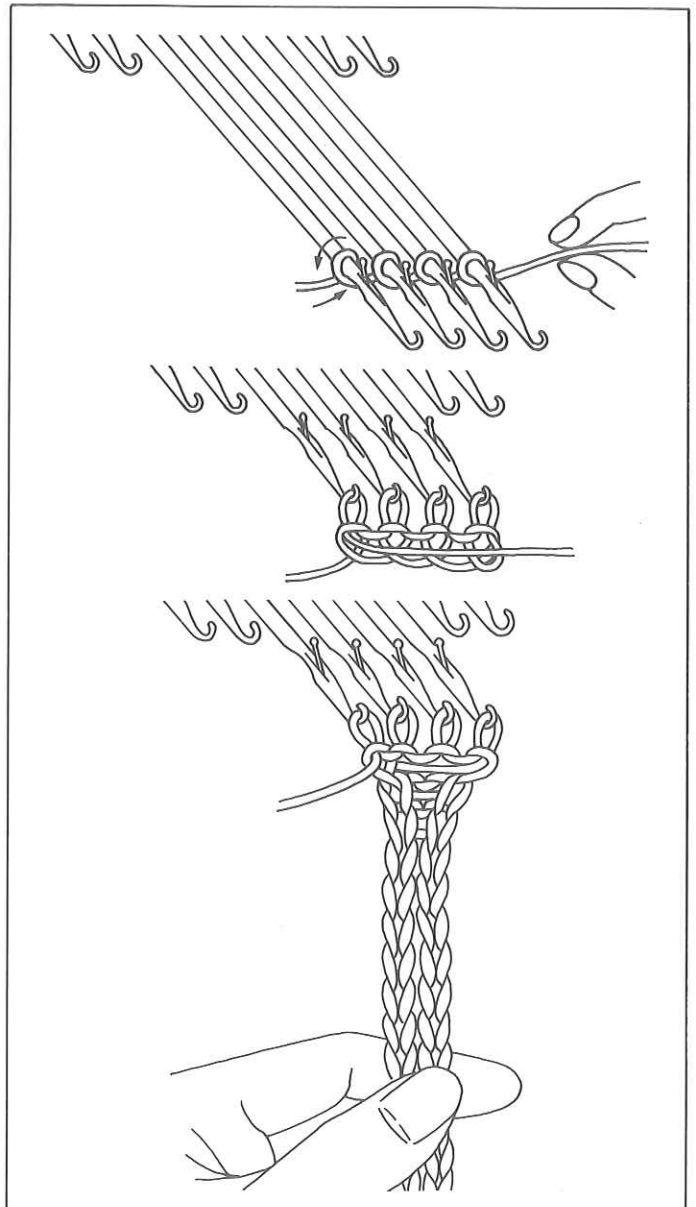

Pompon

- (1) Cut 2 discs out of cardboard with the same diameter for the size of the pompon with a hole of 1/4 of the diameter.
- (2) Thread the Tapestry Needle with yarn for the pompon, wind evenly around the discs until the centre hole is almost filled.
- (3) Insert one scissor blade between the 2 discs and cut all around the yarn.
- (4) Open the discs and with cotton thread, tie the centre together.
Pull out the discs and trim the pompon into shape.

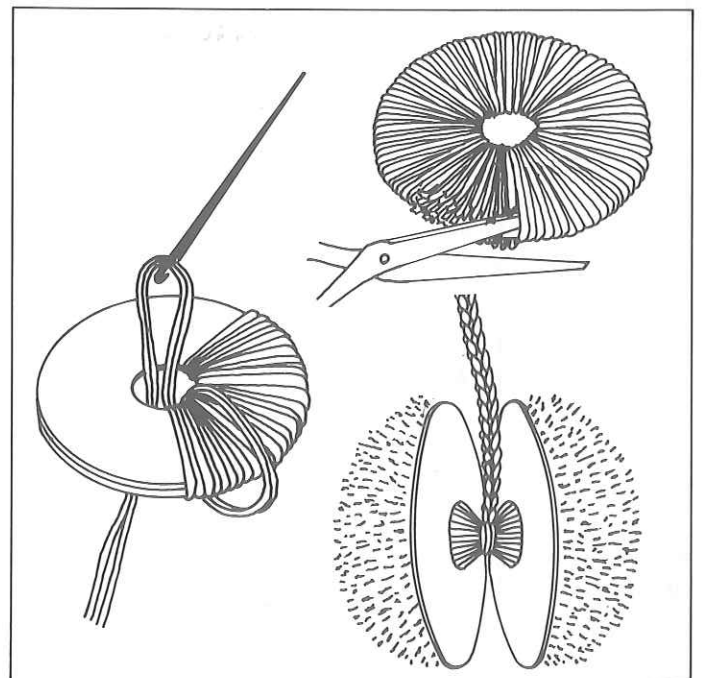

KNITTING GUIDE

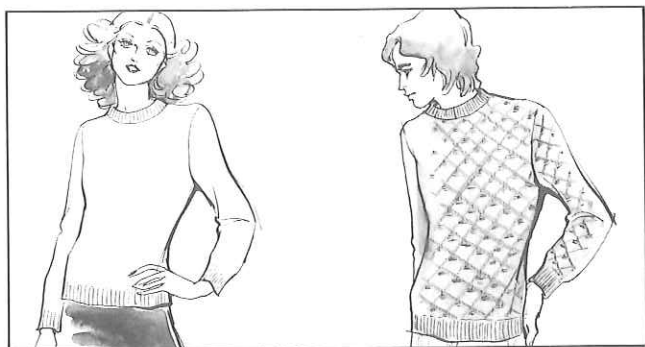

It is advisable to knit the Lady's or Man's Pullover as a first try (refer to Page 13) before knitting the other types of garment, as the pullover requires most of the basic techniques necessary for garment making and these techniques are applicable to other garments.

A - 2

LADY'S CARDIGAN

C - 2

CHILD'S CARDIGAN

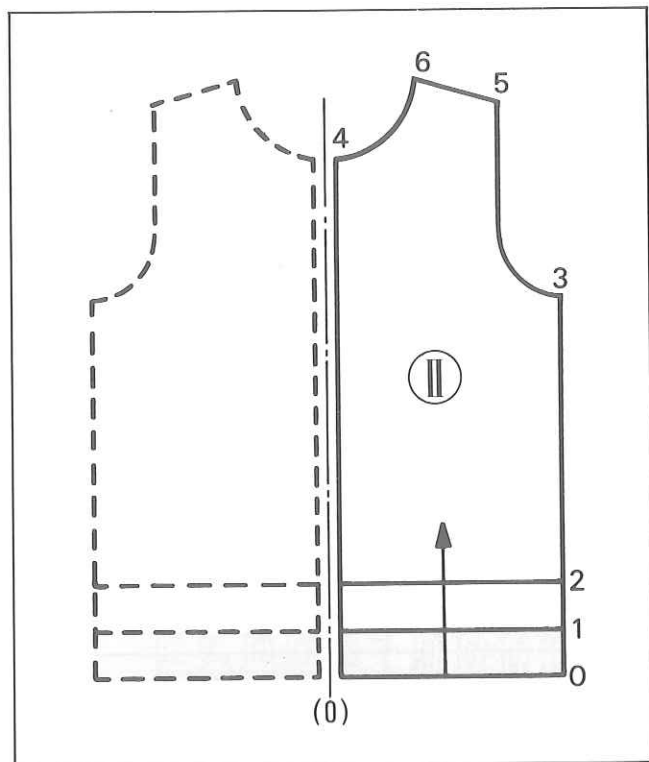

Back - pattern ①

Knit in the same manner as for the back of the LADY'S PULLOVER (refer to page 13).

Fronts - pattern ②

Knit the right and left fronts in a symmetrical pattern.

- At the starting line "0" or "1", cast on stitches on either side of centre (0).
- Turn up for welt in mock rib or transfer stitches onto knitter in K1.P1. rib.
- Knit straight up to "3".
- Knit up to "4", decreasing on the side of armhole.
- Knit up to "5", decreasing at the neck edge.
- Knit up to "6", decreasing on the shoulder.

Borders - pattern ③

- Before knitting the border, mark the position for buttonholes on the pattern.
- Knit two pieces of the border in the same pattern.
- At the starting line "1", cast on twice the number of stitches as read on the Stitch Scale.
- Knit in K1.P1. rib up to "2".
- Transfer stitches onto knitter and cast off.

Sleeves - pattern ④

Knit in the same manner as for sleeve of the LADY'S PULLOVER (refer to page 17).

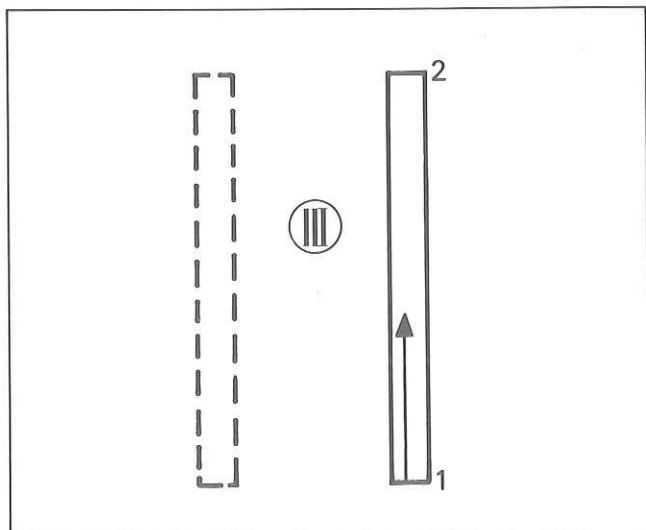

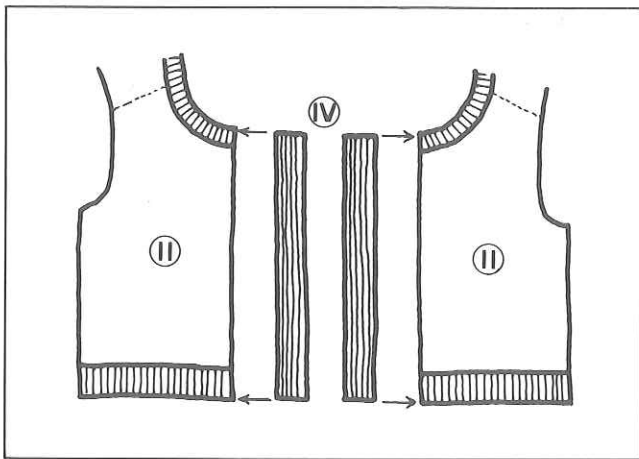

Neckband — pattern ⑤

Join both shoulders before knitting the neckband.

In the same manner as for neckband of the LADY'S PULLOVER, knit the neckband and join it to the neck edge (refer to page 18).

Making up

- Join both borders to the front edges. (Illustration)
- Join the side and sleeve seams.
- Set in sleeves.

A — 3

LADY'S RAGLAN SLEEVE PULLOVER

B — 3

MAN'S RAGLAN SLEEVE PULLOVER

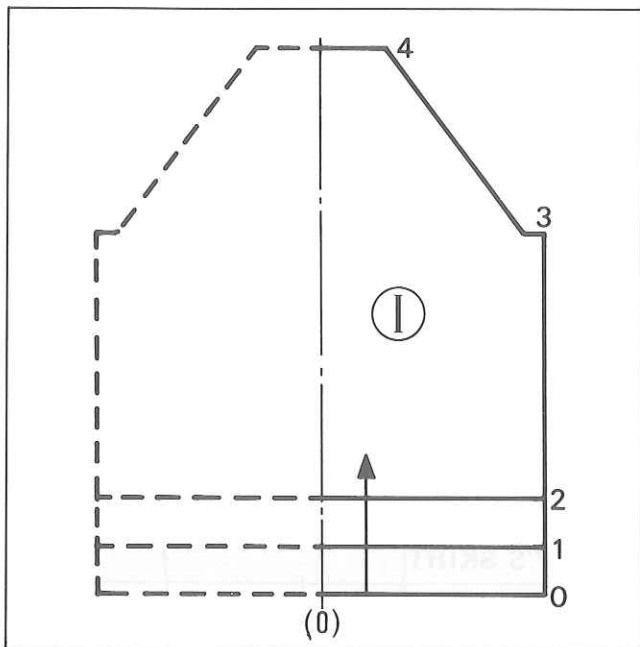

Back — pattern ①

- At the starting line "0" or "1", cast on stitches on both sides of centre (0).
- Work mock rib or K1.P1. rib up to "2".
- Turn up for welt in mock rib or transfer stitches onto knitter in K1.P1. rib.
- Knit straight up to "3".
- Knit up to "4", decreasing on both sides.
- Cast off.

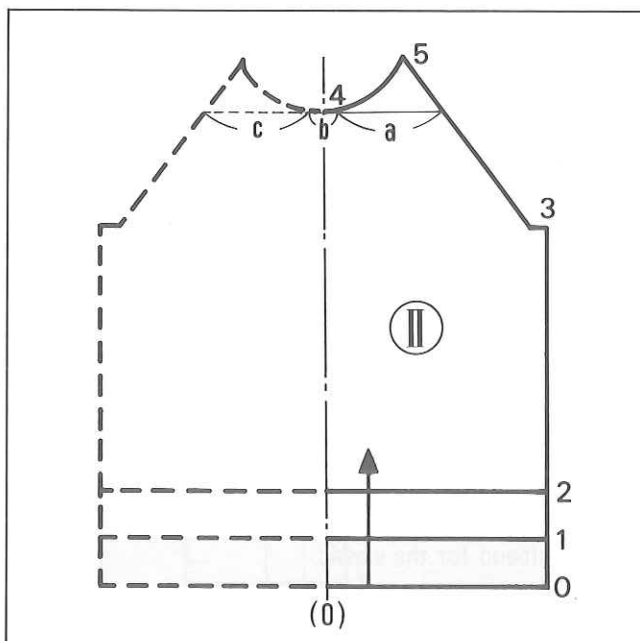

Front — pattern ②

- At the starting line "0" or "1", cast on stitches on both sides of centre (0).
- Work mock rib or K1.P1. rib up to "2".
- Turn up for welt in mock rib or transfer stitches onto knitter in K1.P1. rib.
- Knit straight up to "3".
- Knit up to "4", decreasing on both sides.
- Push the needles for sections "b" and "c" to holding position.
- For section "a", knit up to "5", decreasing on both side.
- Cast off the stitches for section "b".
- Push the remaining needles to knitting position, then knit in the same manner as done for section "a" but reversing the shape.

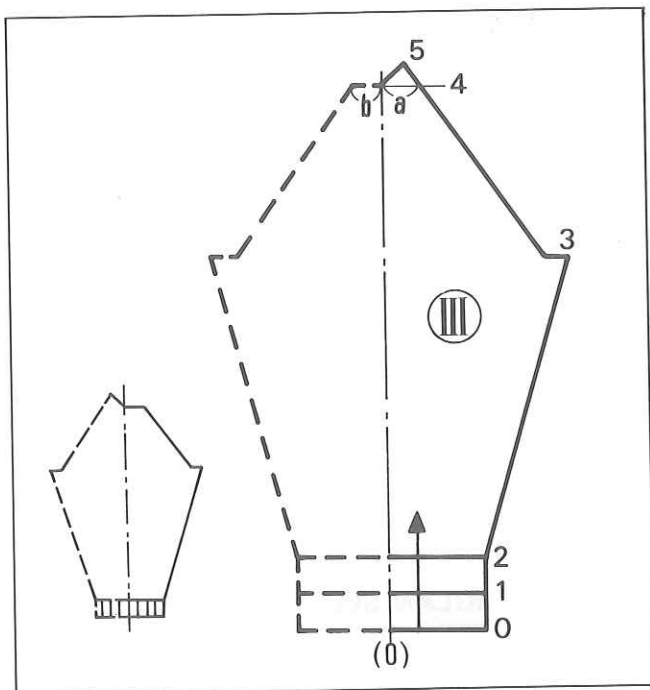

Sleeves – pattern (III)

- At the starting line "0" or "1", cast on stitches on both sides of centre (0).
- Work mock rib or K1.P1. rib up to "2".
- Turn up for cuff in mock rib or transfer stitches onto knitter in K1.P1. rib.
- Knit up to "3", increasing on both sides.
- Knit up to "4", decreasing on both sides.
- Decrease for section "b".
- For section "a", knit up to "5", decreasing on both sides.

Knit the other sleeve on the same pattern but reversing the shape.

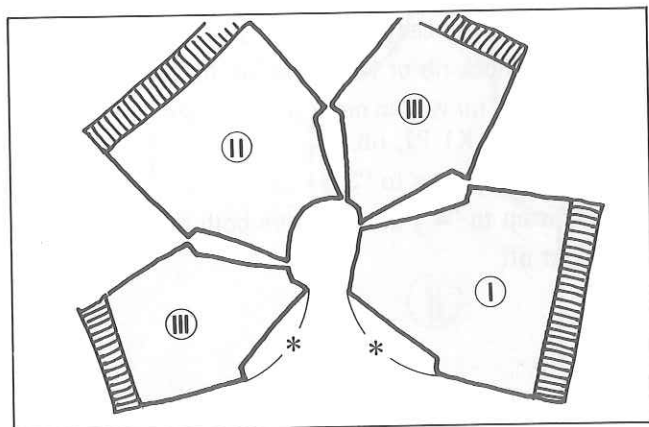

Neckband – pattern (IV)

Before knitting the neckband, join three raglan seams except for the back left raglan line (*). (Illustration)

Knit in the same manner as for neckband of the LADY'S PULLOVER (refer to page 18).

Making up

- Join the remaining raglan seam.
- Join both the side and sleeve seams continuously.

A – 4

LADY'S SKIRT

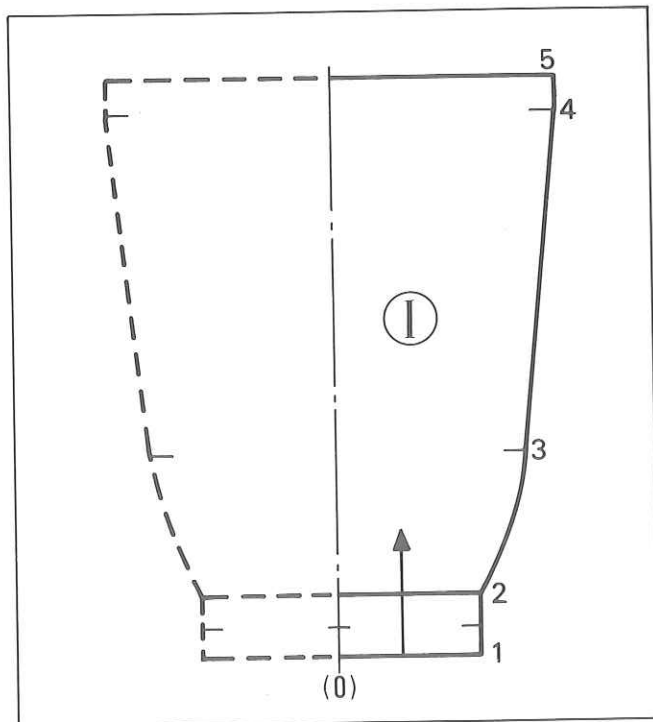

For 2 panels – pattern (I)

For 4 panels – pattern (II)

Knit two (four) pieces of the same pattern.

- At the starting line "1", cast on stitches on both sides of centre (0).
- Knit up to "2" and turn up for waistband.
- Knit up to "3", increasing on both sides.
- Put yarn marks on both sides.
- Knit up to "4", increasing on both sides.
- Put yarn mark through the row.
- With the Stitch Dial one number lower than the main tension, knit in stockinet up to "5" and cast off.

Making up

- Join the side seams leaving an opening inside the waistband for the elastic.
- Fold in the hem and stitch it down.
- Insert elastic through the waistband.

A - 5

LADY'S SLACKS

C - 4

CHILD'S SLACKS

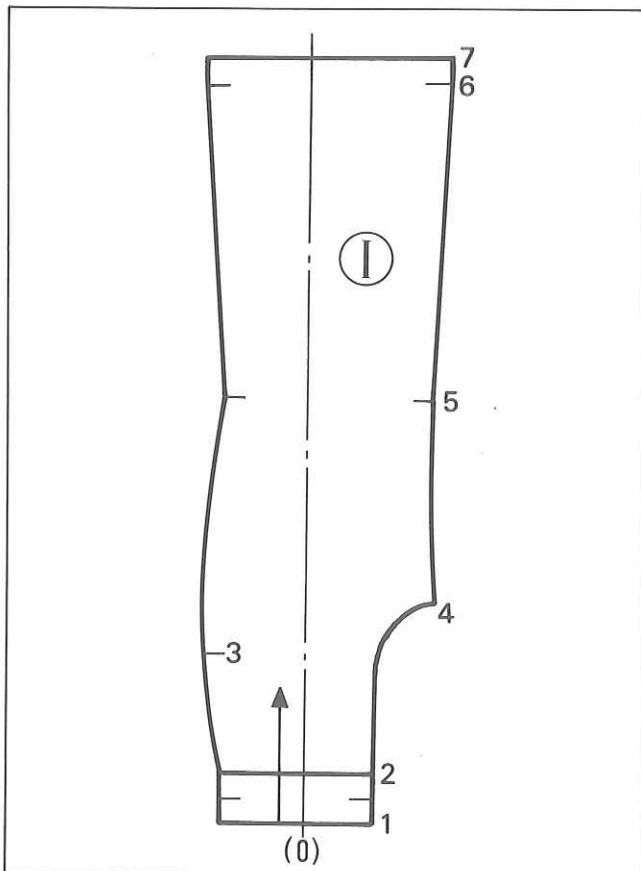

- Knit two pieces each for front and back legs, but reverse shaping.
- Use the Centre Scale.

Front legs - pattern ①

- At the starting line "1", cast on stitches required respectively on each side of centre (0).
- Knit up to "2" and turn up for waistband.
- Knit up to "3", increasing for the side.
- Put yarn mark at the side edge.
- Knit up to "4", increasing for the crutch.
- Knit up to "5", decreasing on both sides.
- Put yarn marks on both sides.
- Knit up to "6", increasing on both sides.
- Put yarn mark through the row.
- With the Stitch Dial one number lower than the main tension, knit in stockinet up to "7".
- Cast off.

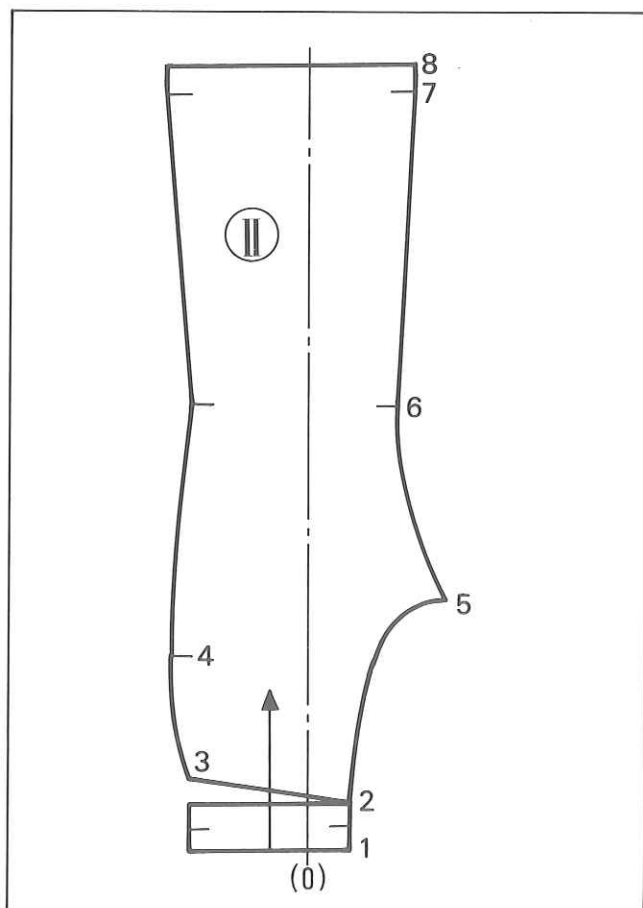

Back legs - pattern ②

- Knit up to "2" in the same manner as done for the front.
- Knit 1 row and push all needles to holding position.
- Work partial knitting by increasing stitches up to "3".
- Knit up to "4", increasing on both sides.
- Put yarn mark at the side edge.
- Knit up to "5", increasing for the crutch.
- Knit up to "6", decreasing on both sides.
- Put yarn marks on both sides.
- Knit up to "7", increasing on both sides.
- Put yarn mark through the row.
- With the Stitch Dial one number lower than the main tension, knit in stockinet up to "8".
- Cast off.

Making up

- Join the centre front and back seams.
- Join the leg seams leaving an opening inside the waistband for the elastic.
- Fold in the hems and stitch them down.
- Insert elastic through the waistband.

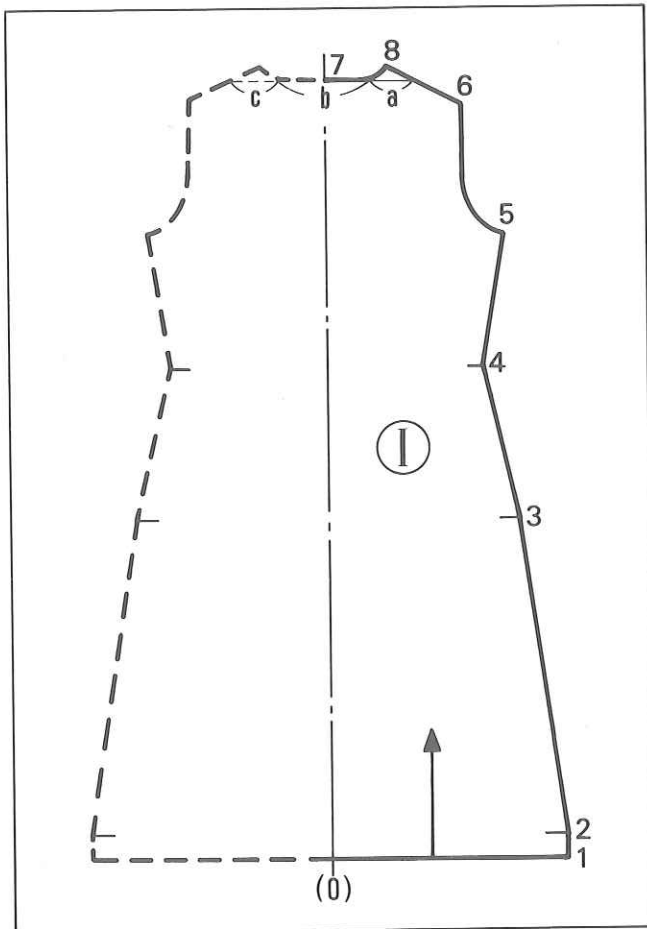
**Back** - pattern ①

- At the starting line "1", cast on stitches on both sides of centre (0).
- With the Stitch Dial one number lower than the main tension, knit in stockinet up to "2".
- Put yarn mark through the row.
- Knit up to "3", decreasing on both sides.
- Put yarn mark on both sides.
- Knit up to "4", decreasing on both sides.
- Put yarn mark on both sides.
- Knit up to "5", increasing on both sides.
- Knit up to "6", decreasing on both sides.
- Knit up to "7", decreasing on both sides.
- Push the needles for sections "b" and "c" to holding position.
- For section "a", knit up to "8", decreasing at the neck edge and on the shoulder respectively.
- For section "b", cast off.
- Push the remaining needles to knitting position, then knit in the same manner as done for section "a" but reversing the shape.

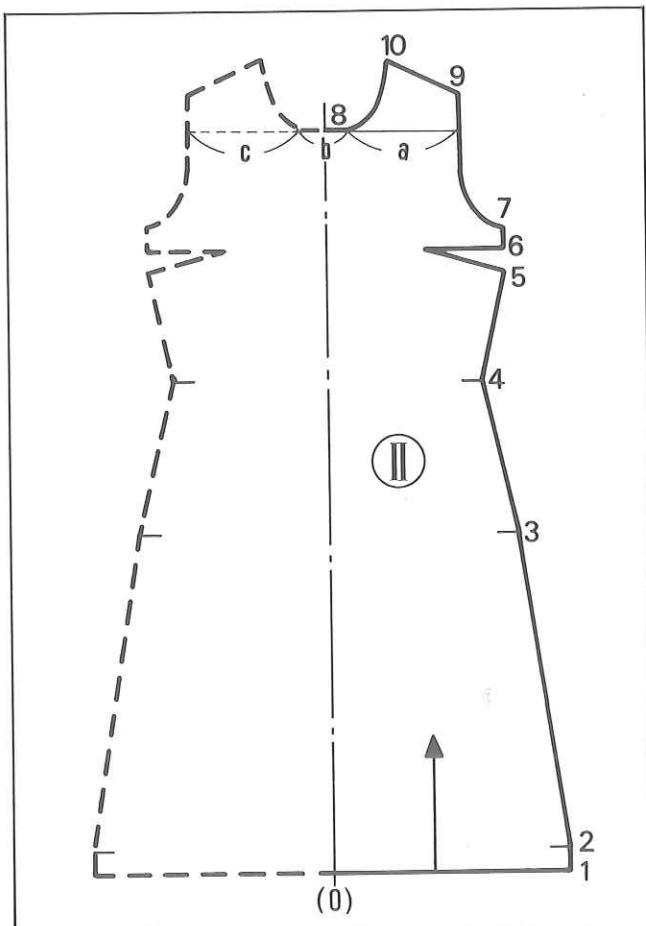
**Front** - pattern ②

- Knit up to "5" in the same manner as done for the back.
- For the bust darts, work partial knitting on both sides up to "6".
- Knit straight up to "7".
- Knit up to "8", decreasing on both sides.
- Push the needles for sections "a" and "b" to holding position.
- For section "c", remove on waste knitting.
- For section "b", cast off.
- For section "a", knit up to "9", decreasing at the neck edge.
- Knit up to "10", decreasing on the shoulder.
- Replace the stitches for section "c" onto the needles, then knit in the same manner as done for section "a" but reversing the shape.

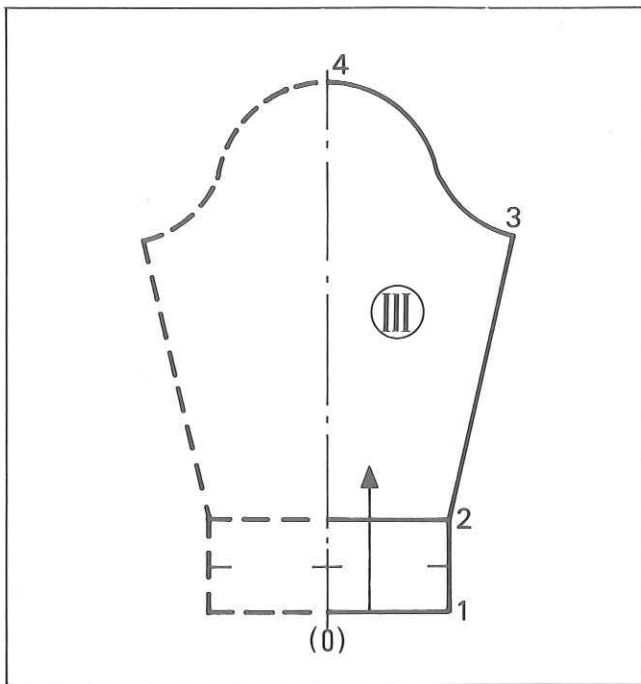

Sleeves – pattern III

- At the starting line "1", cast on stitches on both sides of centre (0).
- Work mock rib or K1.P1. rib up to "2".
- Transfer stitches onto knitter in K1. P1. rib and turn up for cuff.
- Knit up to "3", increasing on both sides.
- Knit up to "4", decreasing on both sides.
- Cast off the remaining stitches.

Neckband – pattern IV

Join the right shoulder before knitting the neckband.

- At the starting line "1", cast on stitches on both sides of centre (0).
- Work mock rib or K1.P1. rib up to "2".
- Transfer stitches onto knitter in K1. P1. rib and turn up for band.
- Join to the neck edge (refer to page 18).

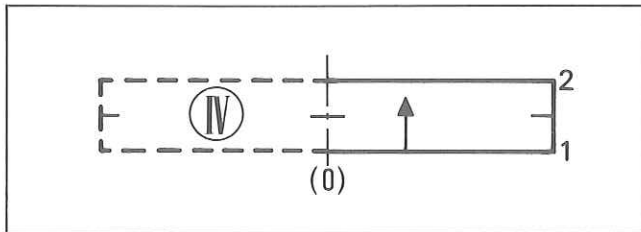

Making up

- Join the left shoulder.
- Join the side and sleeve seams.
- Set in the sleeves.
- Fold in the hems and stitch them down.

B – 2

MAN'S CARDIGAN

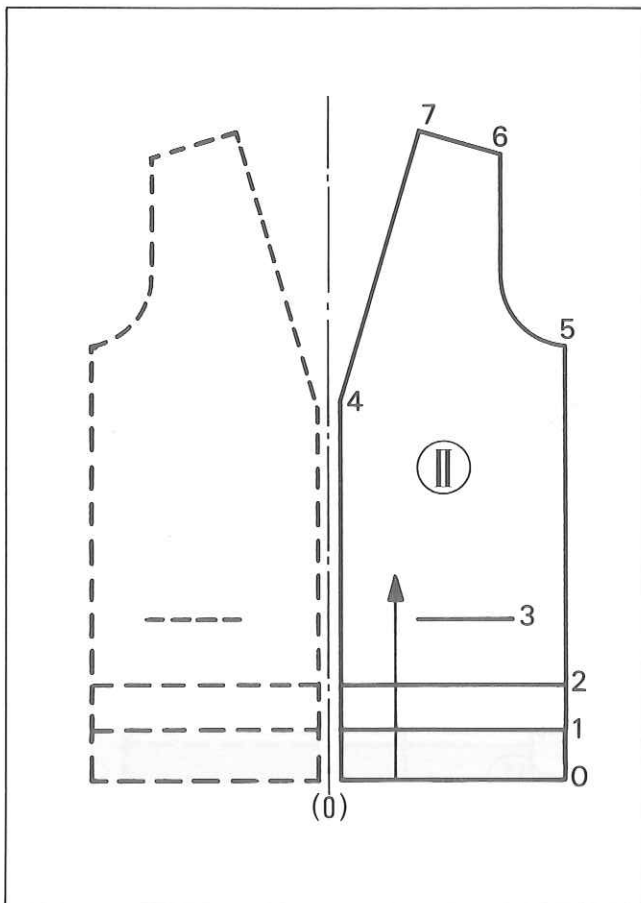

Back – pattern I

Knit in the same manner as for back of the MAN'S PULLOVER (refer to page 13).

Fronts – pattern II

Knit the right and left fronts in a symmetrical pattern.

- At the starting line "0" or "1", cast on stitches on either side of centre (0).
- Work mock rib or K1.P1. rib up to "2".
- Turn up for welt in mock rib or transfer stitches onto knitter in K1. P1. rib.
- Knit straight up to "3".
- Knit a contrast coloured yarn by hand for the pocket opening.
- Knit straight up to "4".
- Knit up to "5", decreasing at the neck edge.
- Knit up to "6", decreasing on both sides.
- Knit up to "7", decreasing on the shoulder.

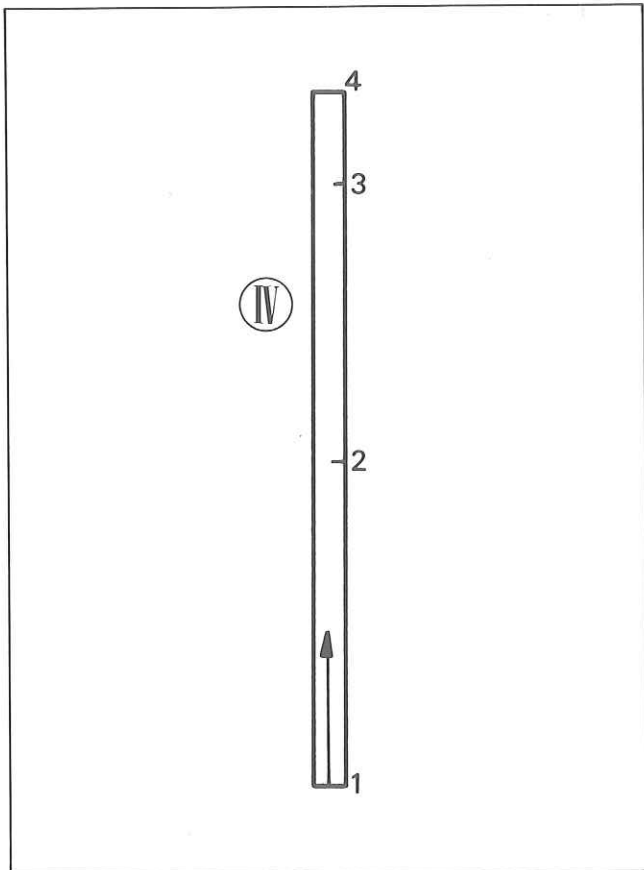

Sleeves – pattern ③

Knit in the same manner as for sleeve of the MAN'S PULLOVER (refer to page 17).

Border – pattern ④

- Space out and mark buttonhole positions between "1" and "2".
- At the starting Line "1" cast on twice the number of stitches read on the stitch scale.
- Knit in K1.P1. Rib up to "4" making buttonholes where marked and putting yarn marks at "2" and "3".
- Return the Pattern Paper to "1".
- Without yarn marks or buttonholes, knit up to "4".
- Transfer stitches onto knitter and cast off.

Fold the Border Band in half lengthways and place yarn marks on the second half to correspond with the first half. (Illustration)

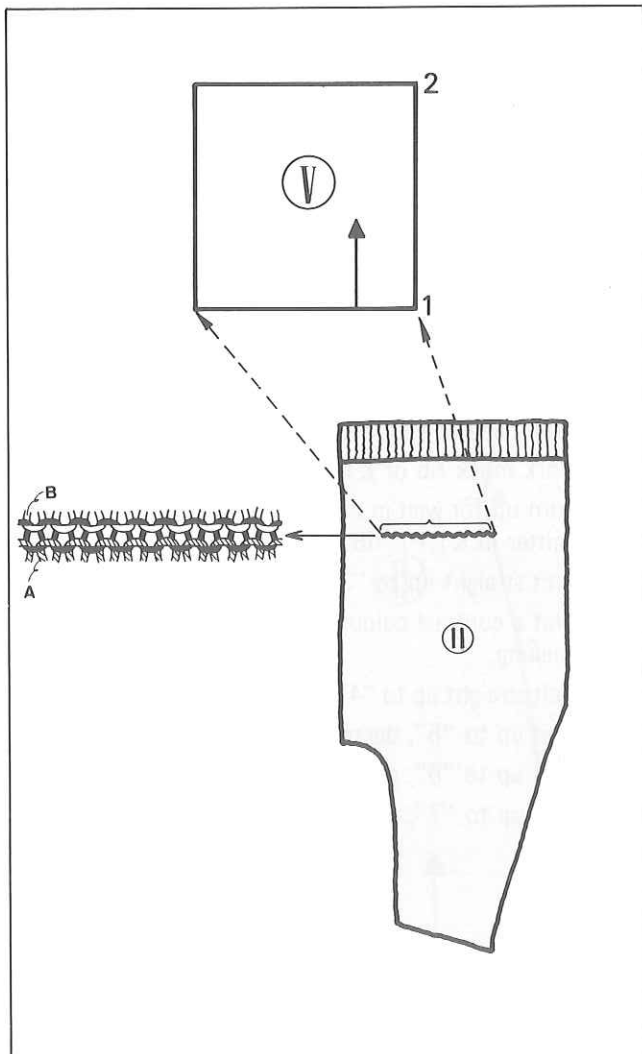
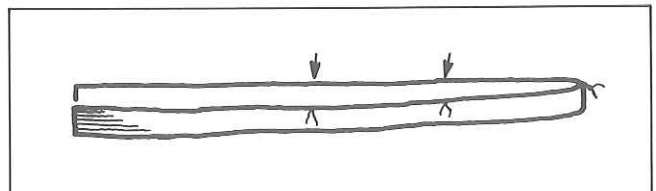

Pockets – pattern ⑤

Knit two pieces with the same pattern.

- At the starting line "1", push the required number of needles to B position.
- Pick up stitches on the row (A) interlooped with the contrast yarn for the pocket opening. (Illustration)
- Knit in stockinet up to "2".
- Cast off.

Pocket bands – pattern ⑥

Knit two pieces in the same manner.

- At the starting line "0" or "1", cast on stitches on both sides of centre (0).
- Work mock rib or K1.P1. rib up to "2".
- Turn up for band in mock rib or transfer stitches onto knitter in K1.P1. rib.
- Pick up stitches on the row (B) interlooped with the contrast yarn for the pocket opening. (Illustration)
- Knit 1 row with the Stitch Dial 3–4 numbers higher and cast off.

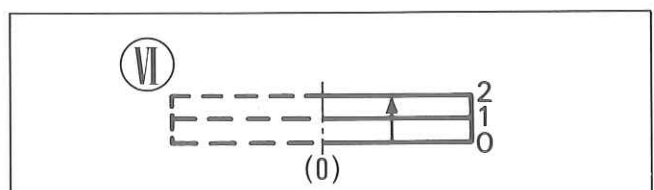

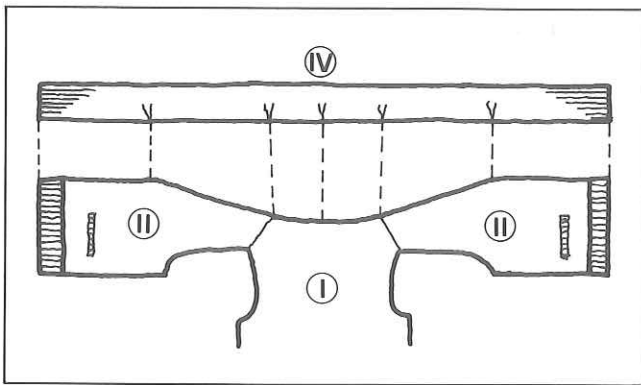

Making up

- Stitch down the pockets and bands.
- Join both shoulders.
- Join the border to the front centre and neck edge. (Illustration)
- Join the side and sleeve seams.
- Set in the sleeves.
- Make buttonholes and sew buttons on the border.

C - 1

CHILD'S PULLOVER

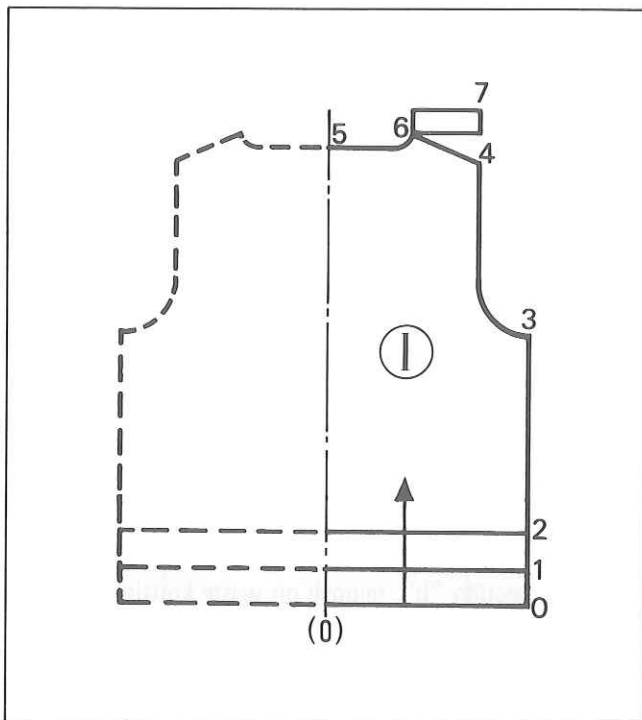

Sizes C, D and E require the same manner as for the LADY'S PULLOVER (refer to page 13). A and B have a shoulder opening and require slightly different techniques for shaping the shoulder.

The instructions given here are for making a shoulder opening and joining the neckband.

Back - pattern I

In the same manner as for back of the LADY'S PULLOVER (refer to page 13), knit up to neck point "6" by working partial knitting on the left shoulder, then knit the underlap continuously in the following manner.

- Push the needles for the left shoulder to knitting position.
- Knit in stockinet up to "7".
- Put yarn mark through the row.
- Return the Pattern Paper to "6" and knit up to "7" once more.
- Cast off.

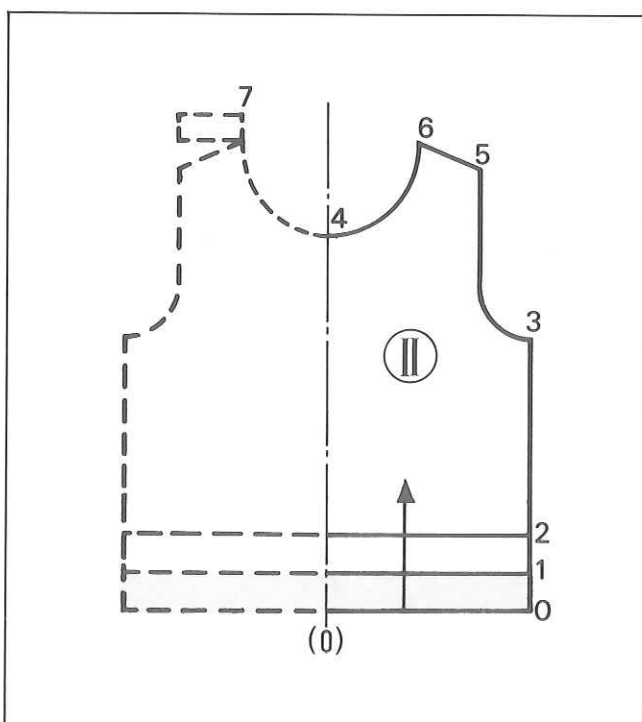

Front - pattern II

In the same manner as for front of the LADY'S PULLOVER (refer to page 15), knit up to neck point "6" by working partial knitting on the left shoulder, then knit the facing continuously in the following manner.

- Put yarn mark through the row.
- Knit in stockinet up to "7".
- Cast off.

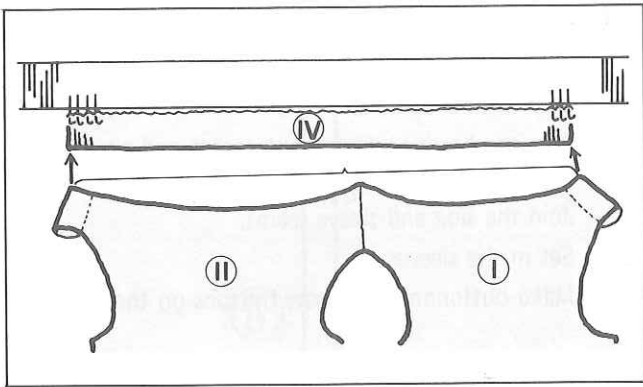

Neckband — pattern ④

Before knitting the neckband, join the right shoulder, fold in the facing and underlap at the yarn mark and stitch down onto the shoulder.

Knit in the same manner as for the neckband of the LADY'S PULLOVER (refer to page 18).

After knitting the neckband, join it to the neck edge. (Illustration)

C — 3

CHILD'S RAGLAN SLEEVE PULLOVER

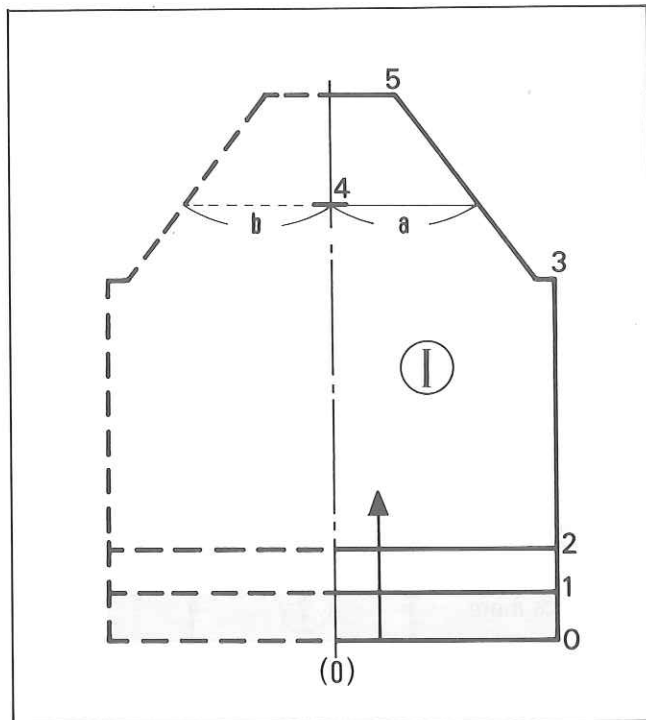

Knit in the same manner as for the LADY'S RAGLAN SLEEVE PULLOVER (refer to page 40) except for the back of size A and B with a back opening.

The instructions given here are for knitting the back and for joining the neckband of size A or B.

Back — pattern ①

- At the starting line "0" or "1", cast on stitches on both sides of centre (0).
- Work mock rib or K1.P1. rib up to "2".
- Turn up for welt in mock rib or transfer stitches onto knitter in K1.P1. rib.
- Knit straight up to "3".
- Knit up to "4", decreasing on both sides.
- Push the needles for section "a" to holding position.
- For section "b", remove on waste knitting.
- For section "a", knit up to "5", decreasing on the raglan edge, then cast off.
- Replace the stitches for section "b" onto the needles, then knit in the same manner as done for section "a", but reversing the shape.

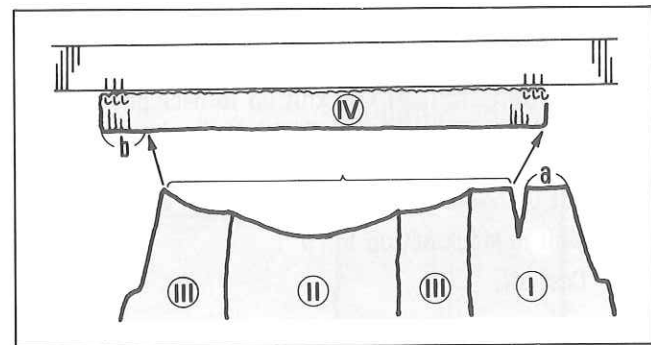

Join the neckband to the neck edge on the machine in the manner as shown. Then revolve the remaining neck edge "a" to the other side "b" and join them in the same manner.

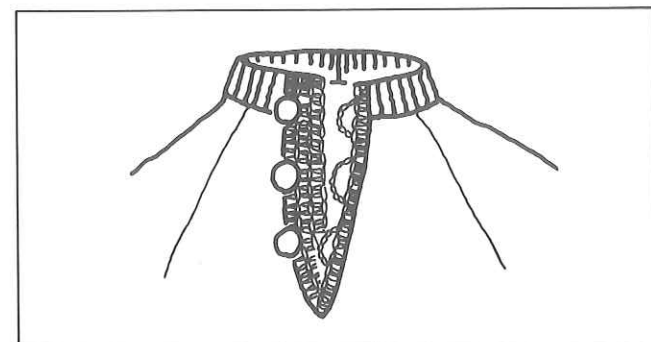

Making up

Trim the back opening in crochet stitch, make loop buttonholes and sew on buttons. (Illustration)

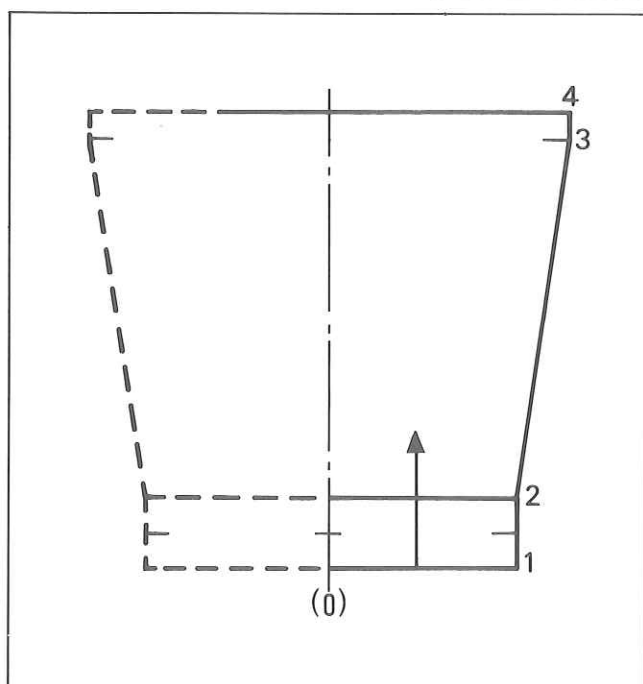

Knit two pieces of the same pattern.

- At the starting line "1", cast on stitches on both sides of centre (0).
- Knit up to "2".
- Turn up for waistband.
- Knit up to "3", increasing on both sides.
- Put yarn mark through the row.
- With the Stitch Dial one number lower than the main tension, knit in stockinet up to "4".
- Cast off.

Making up

- Join the side seams leaving an opening inside the waistband for the elastic.
- Fold in the hem and stitch it down.
- Insert elastic through the waistband.

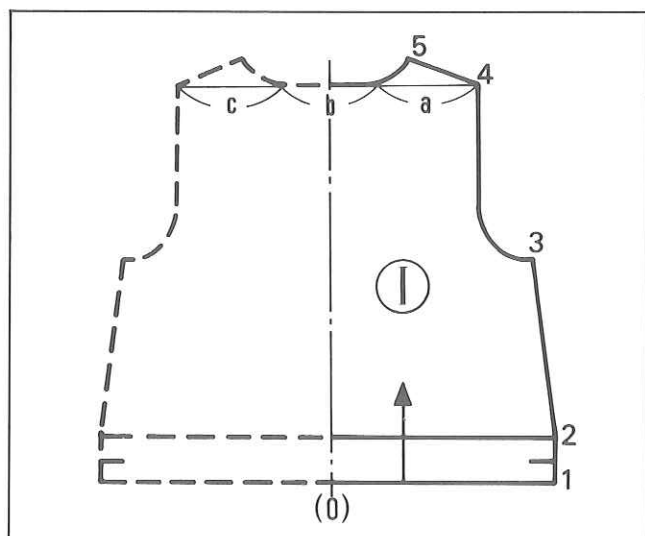

Back - pattern ①

- At the starting line "1", cast on stitches on both sides of centre (0).
- Knit up to "2" and turn up for hem.
- Knit up to "3", decreasing on both sides.
- Knit up to "4", decreasing on both sides.
- Push the needles for sections "b" and "c" to holding position.
- For section "a", knit up to "5" decreasing at the neck edge and on the shoulder respectively.
- For section "c", push the needles to knitting position and knit up to "5" in the same manner as done for section a but reversing the shape.
- For section "b", cast off.

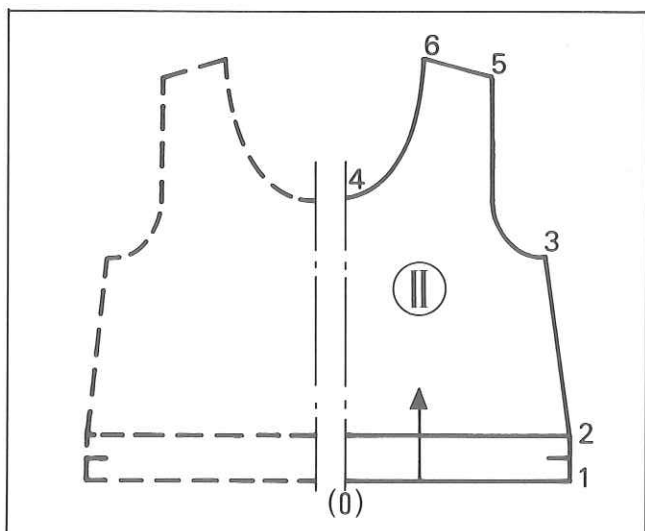

Fronts - pattern ②

Knit the right and left fronts in a symmetrical pattern.

- At the starting line "1", cast on stitches on either side of centre (0).
- Knit up to "2" and turn up for hem.
- Knit up to "3", decreasing on the side edge.
- Knit up to "4", decreasing on the armhole edge.
- Knit up to "5", decreasing at the neck edge.
- Knit up to "6", decreasing on the shoulder.

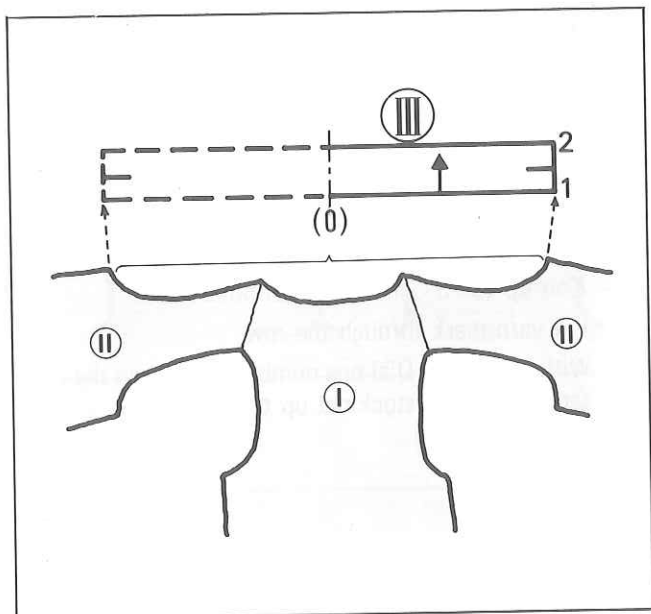

Neckband — pattern ③

- Join both shoulders before knitting the neckband.
- Set the Stitch Dial one number lower than the one originally used.
- At the starting line "1", push the required number of needles to B position on both sides of centre(0).
- Pick up the stitches from the neck edge and place them onto the needles. (Illustration)
- With the Stitch Dial one number lower than the main tension, knit up to "2".
- Turn up for neckband.
- Knit 1 row with the Stitch Dial 3–4 numbers higher and cast off.

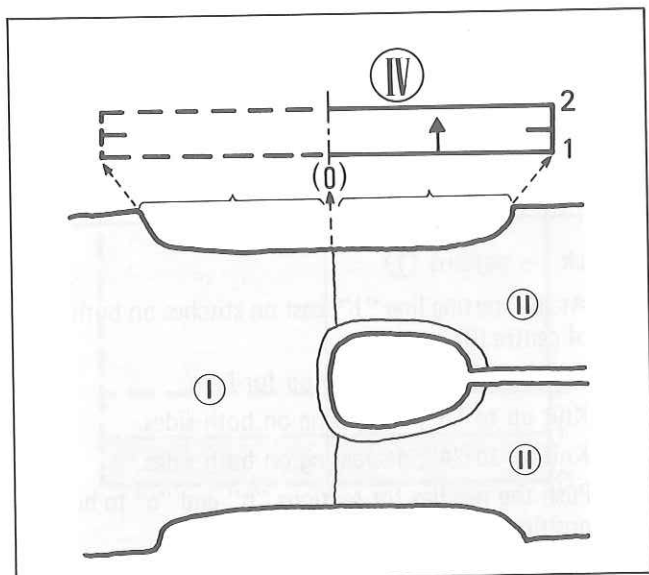

Armbands — pattern ④

- Set the Stitch Dial to the same number as used for the neckband.
- Knit two pieces with the same pattern.

Pick up the stitches from the armhole edge and knit in the same manner as done for the neckband. (Illustration)

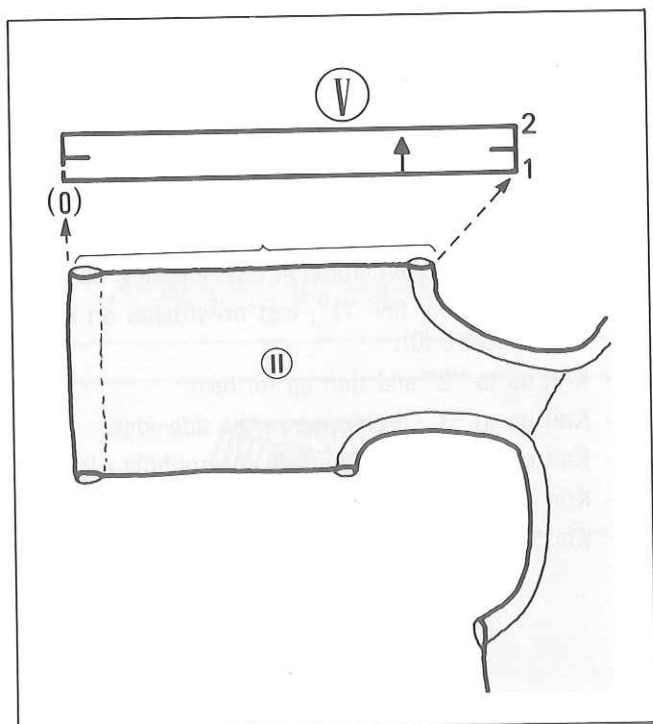

Borders — pattern ⑤

Set the Stitch Dial to the same number as used for the neckband.

- At the starting line "1", push up the required number of needles to B position on either side of centre(0).
- Pick up the stitches from the front centre edge and place them onto the needles. (Illustration)
- With the Stitch Dial one number lower than the main tension, knit up to "2".
- Turn up for border and knit 1 row with the Stitch Dial 3–4 numbers higher to cast off.

Making up

- Join side seams.
- Knit two pieces of cord of about 30cm. long and sew on the neck.
- Make two pompons and attach to the cord.

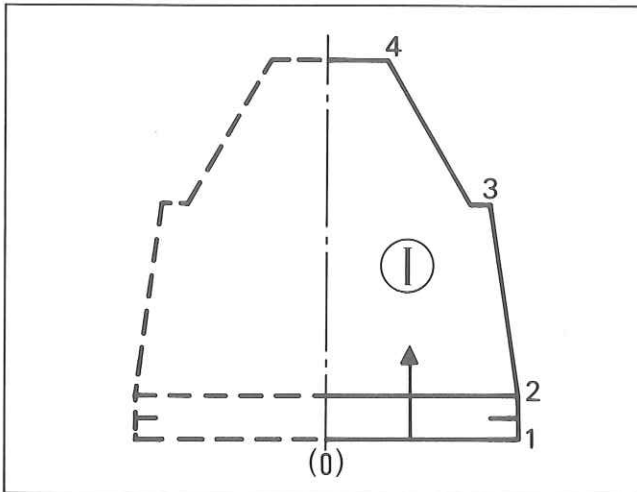
**Back** – pattern ①

- At the starting line "1", cast on stitches on both sides of centre (0).
- Knit up to "2", and turn up for hem.
- Knit up to "3", decreasing on both sides.
- Knit up to "4", decreasing on both sides.
- Cast off.

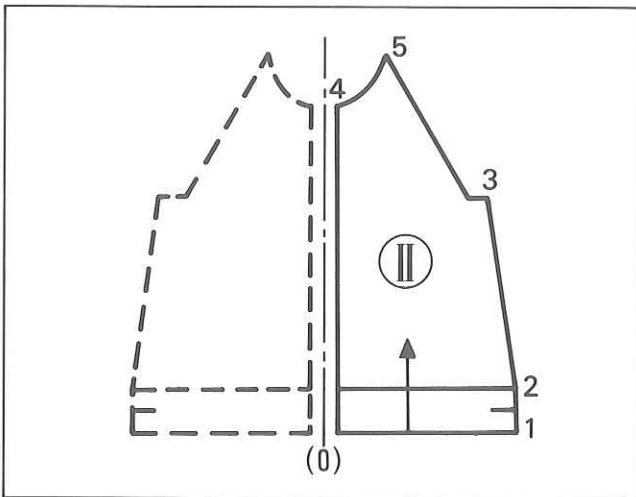
**Fronts** – pattern ②

Knit the right and left fronts in a symmetrical pattern.

- At the starting line "1", cast on stitches on either side of centre (0).
- Knit up to "2" and turn up for hem.
- Knit up to "3", decreasing on the side edge.
- Knit up to "4", decreasing at the raglan edge.
- Knit up to "5", decreasing at the neck edge and the raglan edge respectively.

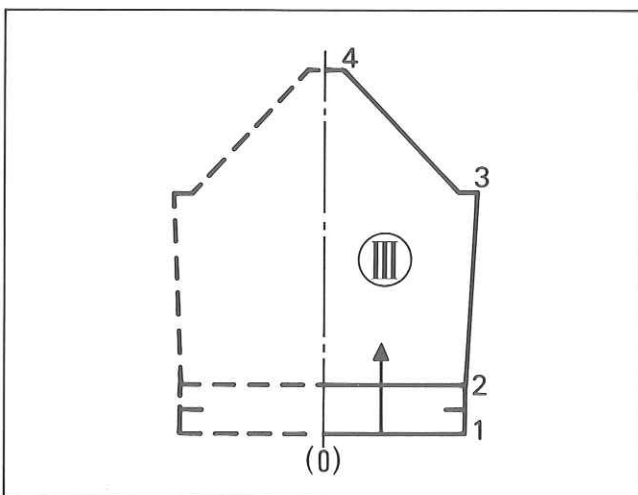
**Sleeves** – pattern ③

- At the starting line "1", cast on stitches on both sides of centre (0).
- Knit up to "2" and turn up for cuff.
- Knit up to "3", increasing on both sides.
- Knit up to "4", decreasing on both sides.
- Cast off.

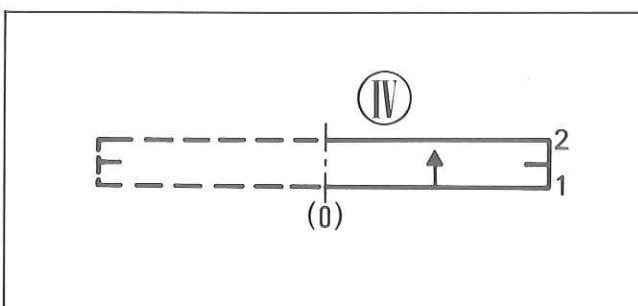
**Neckband** – pattern ④

Join all raglan seams before knitting the neckband.

- At the starting line "1", push the required number of needles to B position on both sides of centre (0).
- Pick up the stitches from the neck edge and place them onto the needles.
- With the Stitch Dial one number lower than the main tension, knit up to "2".
- Turn up for neckband, knit 1 row with the Stitch Dial 3–4 numbers higher and cast off.

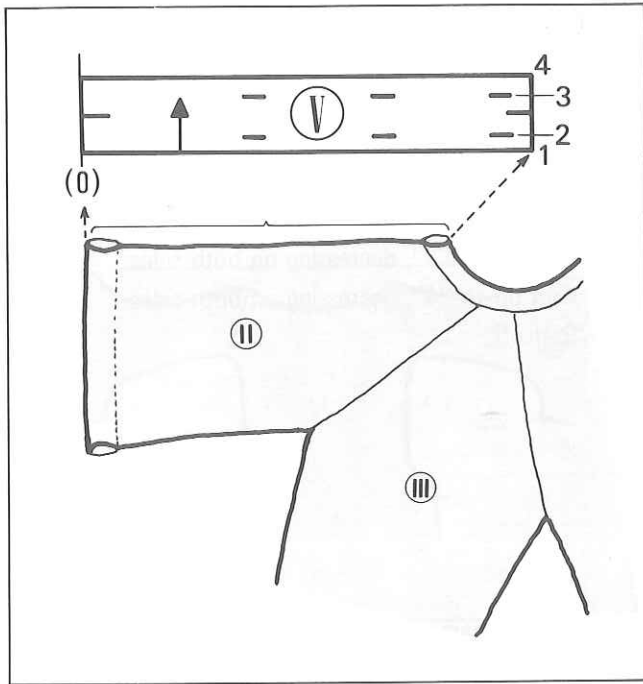

Borders – pattern ⑤

Set the Stitch Dial to the same number as used for the neckband.

- At the starting line "1", push the required number of needles to B position on both sides of centre (0).
- Pick up the stitches from the centre front edge and place them onto the needles. (Illustration)
- Knit up to "4", making buttonholes at "2" and "3".
- Turn up for border, knit 1 row with the Stitch Dial 3–4 numbers higher and cast off.

Knit the other border in the same manner except for the buttonholes.

Making up

- Join the side and sleeve seams.
- Sew on buttons.

C – 8

CHILD'S BRIEF

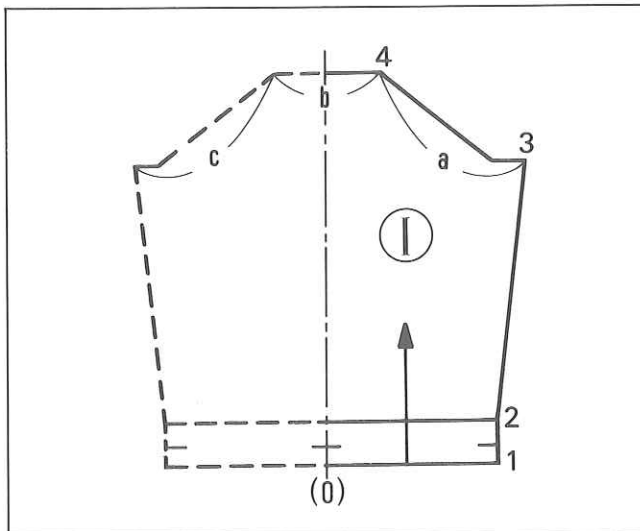

Front – pattern ①

- At the starting line "1", cast on stitches on both sides of centre (0).
- Knit up to "2" and turn up for waistband.
- Knit up to "3", increasing on both sides.
- Work partial knitting on both sides up to "4".
- Push the needles for sections "a" and "c" to holding position.
- For section "b", remove on waste knitting.
- Push the needles for section "a" to knitting position and remove on waste knitting.
- Remove the remaining stitches on waste knitting.

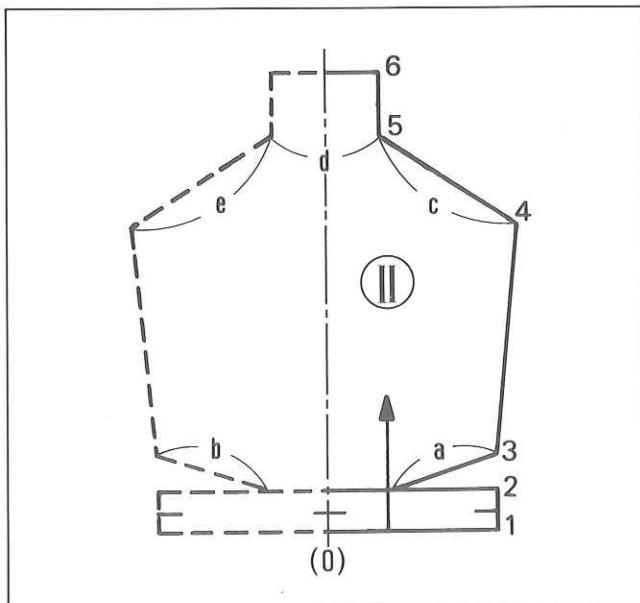

Back – pattern ②

- Knit up to "2" in the same manner as done for the front.
- Knit 1 row and push the needles for sections "a" and "b" to holding position.
- Work partial knitting on both sides up to "3".
- Knit up to "4", increasing on both sides.
- Work partial knitting on both sides up to "5".
- Push the needles for sections "c" and "e" to holding position.
- For section "d", knit up to "6" and remove on waste knitting.
- Remove the stitches for sections "c" and "e" on waste knitting respectively.

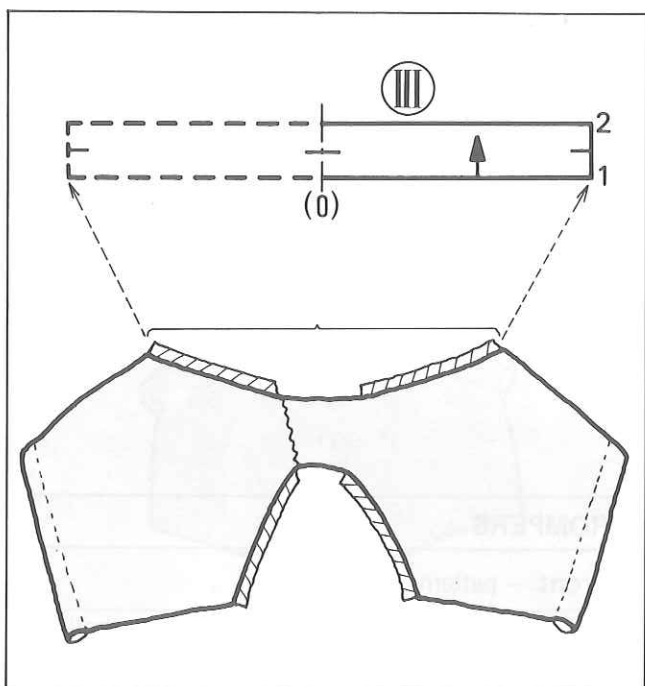

Legbands – pattern ③

- Graft the front and back at the crutch before knitting the legband.
- Knit two pieces with the same pattern.
- At the starting line "1", cast on stitches on both sides of centre (0).
- Work mock rib or K1.P1. rib up to "2".
- Turn up for band in mock rib or transfer stitches onto knitter in K1.P1. rib.
- Pick up the stitches from the leg opening and place them onto the needles. (Illustration)
- Knit 1 row with the Stitch Dial 3–4 numbers higher and cast off.

Making up

- Join the side seams leaving an opening inside the waistband.
- Insert elastic through the waistband.

C – 9

LEGGINGS

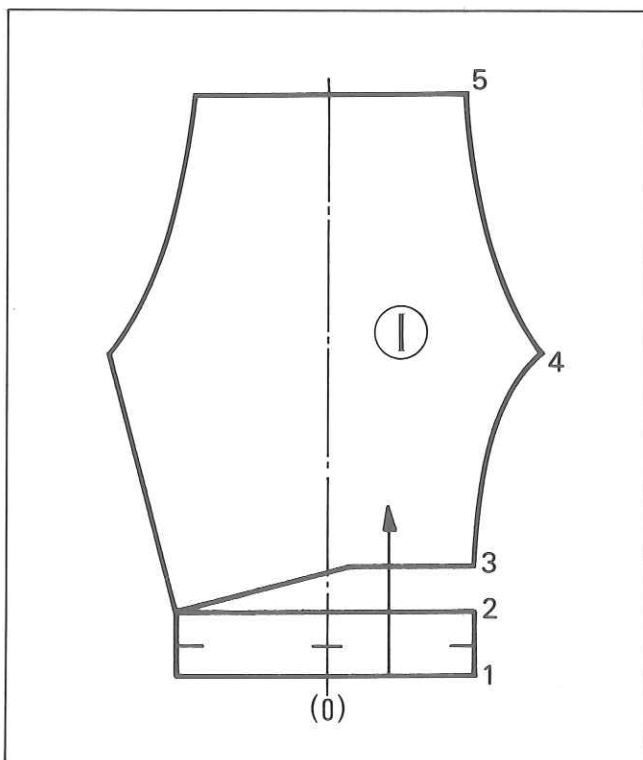

Leggings – pattern ①

- Knit two pieces with the same pattern, but reverse shaping.
- Use the Centre Scale.
- At the starting line "1", cast on stitches required respectively on each side of centre (0).
- Knit up to "2" and turn up for waistband.
- Knit 1 row and push all the needles to holding position.
- Work partial knitting up to "3".
- Knit up to "4", increasing on both sides.
- Knit up to "5", decreasing on both sides.
- Remove the stitches on waste knitting.

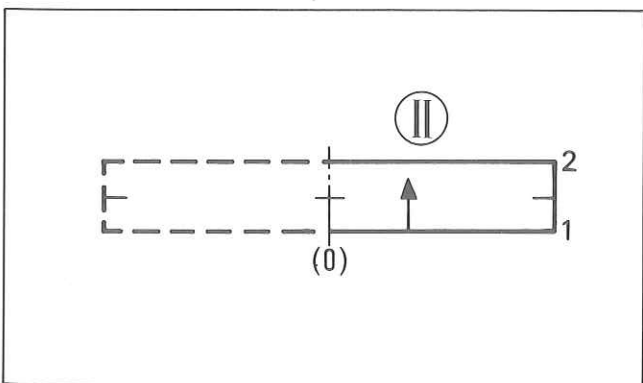

Anklebands – pattern ②

Knit two pieces with the same pattern.

- At the starting line "1", cast on stitches on both sides of centre (0).
- Work mock rib or K1.P1. rib up to "2".
- Turn up band for mock rib or transfer the K1.P1. rib stitches onto the knitter, and knit 1 row.
- Replace the stitches of the ankle edge of the leggings.
- Knit 1 row with the Stitch Dial 3–4 numbers higher and cast off.

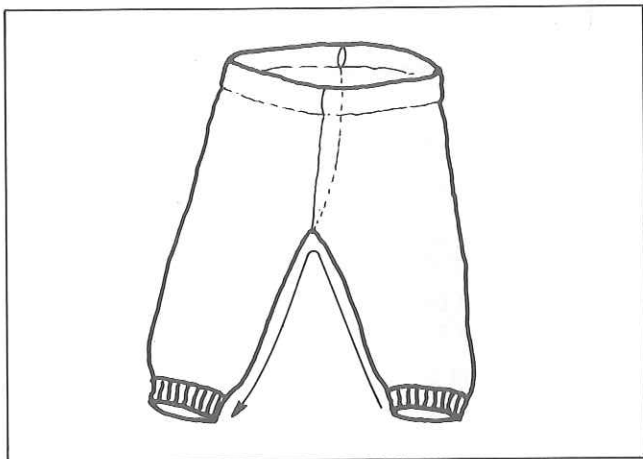

Making up

- Join the centre back and front seams leaving an opening inside the waistband.
- Join the inside leg seams continuously.
(Illustration)
- Insert elastic through the waistband.

C – 10

ROMPERS

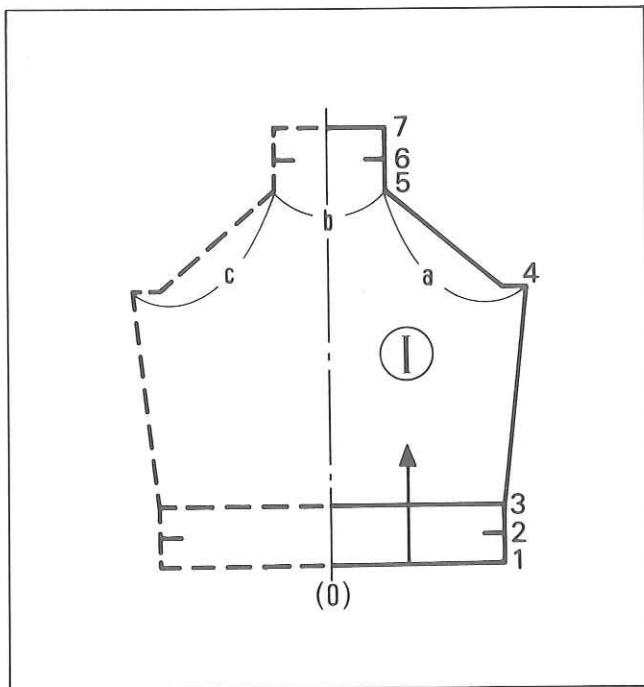

Front – pattern ①

- At the starting line "1", cast on stitches on both sides of centre (0).
- Knit up to "2" and purl the stitches on the row.
- Knit up to "3" and turn up for waistband.
- Knit up to "4", increasing on both sides.
- Work partial knitting on both sides up to "5".
- Push the needles for sections "b" and "c" to holding position.
- For section "a", push the needles to knitting position and remove on waste knitting.
- Remove the stitches for section "c" on waste knitting.
- Push the needles for section "b" to knitting position and knit straight up to "6".
- Put yarn mark through the row.
- Knit in stockinet up to "7" and cast off.

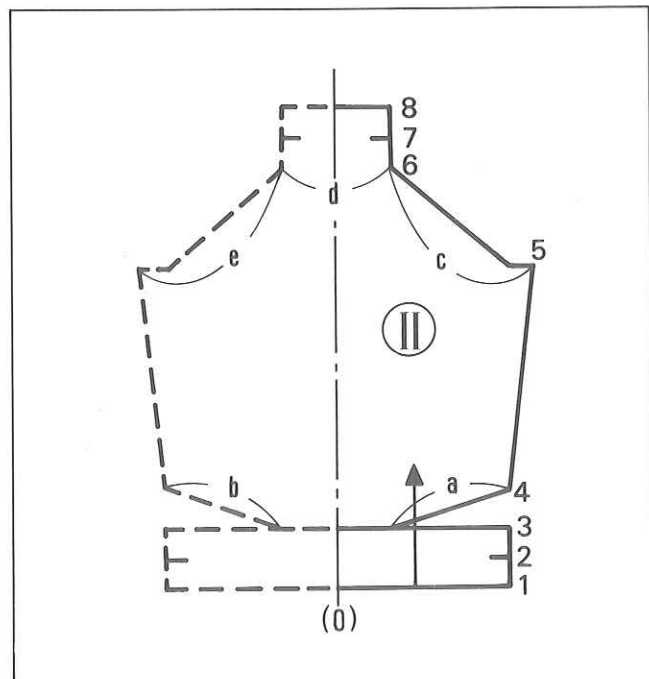

Back – pattern ②

- Knit up to "3" in the same manner as for the front.
- Knit 1 row and push the needles for section "a" and "b" to holding position.
- Work partial knitting up to "4".
- Knit up to "5", increasing on both sides.
- Work partial knitting on both sides up to "6".
- In the same manner as done for the front, remove the stitches for section "c" and "e" on waste knitting.
- For section "d", knit up to "7".
- Put yarn mark through the row.
- Knit in stockinet up to "8".
- Cast off.

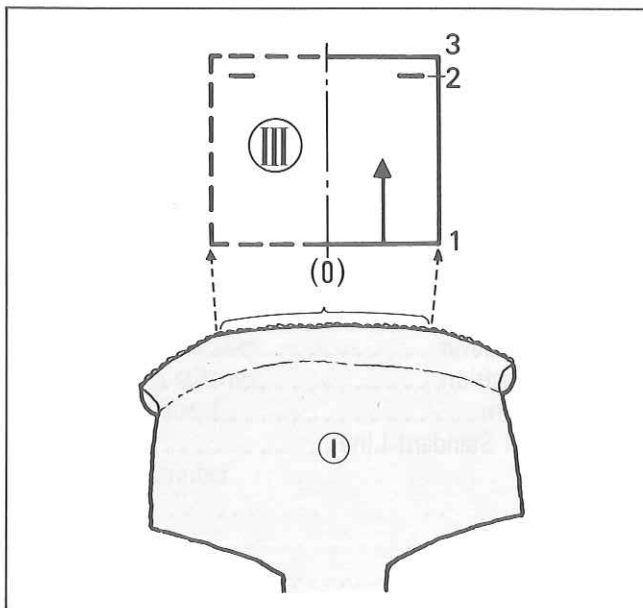

Bib — pattern III

- At the starting line "1", push the needles to B position on both sides of centre (0).
- Pick up the same number of purl stitches from the centre of front waistband and place them onto the needles.
- Knit straight up to "2".
- Make buttonholes.
- Knit up to "3" and cast off.

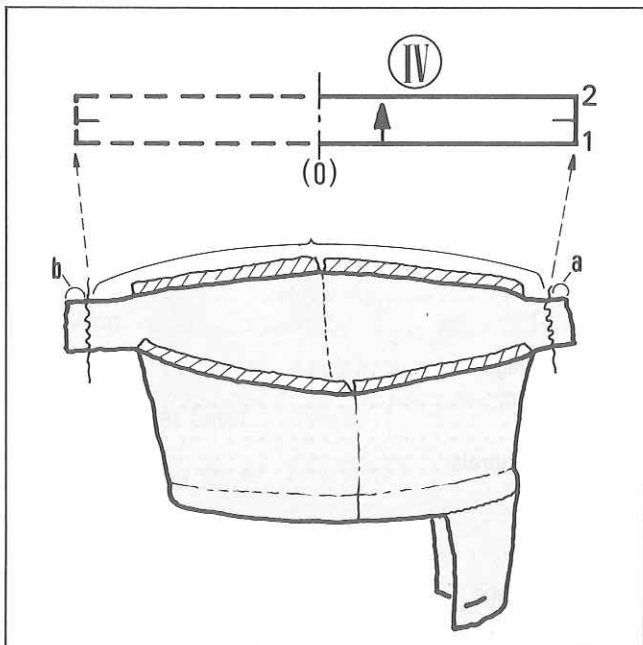

Legbands — pattern IV

- Before knitting the legband, join the side seams.
- Knit two pieces with the same pattern.
- At the starting line "1", cast on stitches on both sides of centre (0).
- Work mock rib or K1.P1. rib up to "2".
- Transfer stitches onto knitter in K1.P1. rib, then turn up for band and knit 1 row.
- Pick up the stitches from the leg opening edge except for sections "a" and "b" and place them onto the needles. (Illustration)
- Knit 1 row with the Stitch Dial 3–4 numbers higher and cast off.

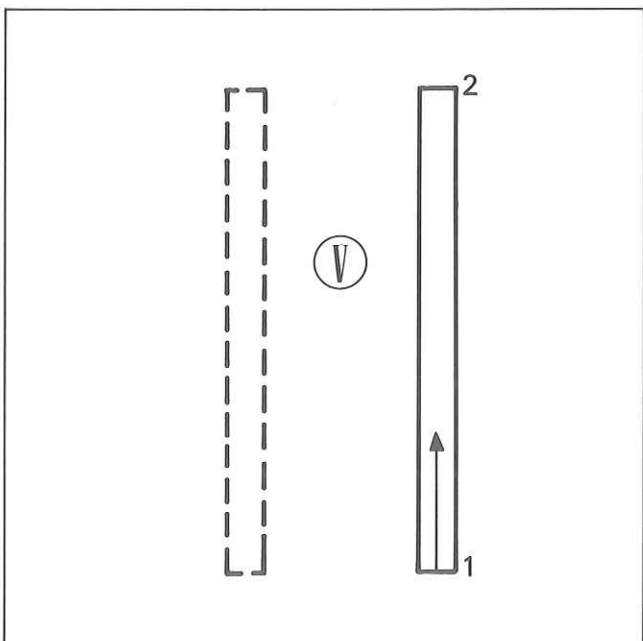

Shoulder straps — pattern V

- Knit two pieces with the same pattern.
- At the starting line "1", cast on for twice the number of stitches as read on the Stitch Scale.
- Knit in K1.P1. rib up to "2".
- Transfer stitches onto knitter and cast off.

Making up

- Stitch down the facings on the crutch.
- If the legbands are knitted in K1.P1. rib, fold them in half and stitch down.
- Trim the edge of the bib in crochet stitch.
- Sew the shoulder straps on and also the buttons.

INDEX

A

Armhole 18, 19
 Arrow 4
 Arrow mark 5

B

Back width 6
 black figure 6
 blocking 17
 body measurement 6
 bust 6
 buttocks 6

C

cable stitch 37
 card memory number 16, 4
 carriage 8
 cast off 30
 cast on 11
 cast on comb 14
 centre(0) 2
 centre line 5, 8
 center scale 9
 centre straight section 14
 change dial 7, 16, 23
 claw weight 29
 clip 7
 contrast yarn 2, 4
 contrast stitch 4
 crochet hook 35
 cuff 22

D

damp cloth 17
 decrease 12
 decreasing 14
 double border 34
 Double Eye Transfer Tool 19

E

ease allowance 6
 edge pin 25, 27
 empty needles 16, 32

F

Feeding Dial 7, 8
 Feed Lever 7, 10

G

garment 18
 Gauge Scale 4

H

Half Pitch Lever 19
 holding position 15, 16
 hooked yarn 34
 Horizontal Standard Line 5, 10

I

increase 12

K

K1, P1, rib 13
 Knit Contour 3, 7
 knitted fabric 1
 knitter 14
 knitter arm 14, 19
 knitting position 16

L

lace carriage 23
 lace fabric 23
 loops 13
 lower numerals 7

M

main carriage 18
 main knitting 15
 main yarn 13
 making up 18, 22
 Measurement Table 5
 multiple stitches 38

N

neckband 18, 22, 35
 neck edge 18, 35
 neckline 14
 neck point 14
 neck side 20
 needle bed 1
 needle hook 3, 25
 needle pusher 3, 14

O

ordinary iron 2

P

page number	5
paper holder	7, 8
Paper Lever	7
Paper Slit	7
partial knitting.	
by decreasing stitches	12
by increasing stitches	12
Pattern Measurement	6
Pattern Paper	5, 7, 8
Pattern Piece Number	5
Pattern Size	5
Pattern Styles	5
Pattern Style Number	5
Pompon	39
pressing	17
Punch Card	15
Punch Card Feeding Dial	23

R

Ravel Cord	26, 28
Release Lever	23
rear slit	8
Ribber	14
Ribber Arm	14, 19
Ribber Weight	14
Row Counter	19
Row Counter Set Lever	23
Row Number	3, 7
Row Number Dial	17
Row Number Window	7
Russel lever	25

S

Shaping Sequence Number	5
shoulder point	6, 14
Side Lever	23, 30
sinker loops	32, 33
sleeve top	22
steam iron	2
Stitch Dial	19
Stitch Scale	3, 7, 9
stitch type	2, 15
Stitch Dial Number	1
Stop Knob	14, 30
stretch	6
Swing indicator	19

T

Tappet Tool	18, 36
Tension Gauge	1, 4, 7, 11
Tension Swatch	1
thick yarn	1, 3
three-eye Transfer Tool	38
Transfer Tool	20, 32

U

underarm	22
upper numerals	7

V

vertebra	6
Vertical Exapansion	23
Vertical Standard Line	5, 10, 11

W

waistband	36
waist curve line	6
waist edge	36
wales	38
waste knitting	15, 30
welt	19
wrist	6

Y

Yarn Feeder	15
-------------	----