

rhapsody

You, in satin
and lace ...
a beautiful
combination!

21-2

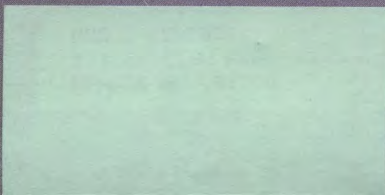

584

perfectly
pleasing

A simple sheath of a Dress, styled to please everyone, is knitted with Bulky Venetia on any standard machine in basic Stockinette stitch. Fisherman Rib for Pockets and a separate removable Collar insert were knitted with regular Venetia using machine with Ribber. Sizes 10 to 16.



594 flattering

Swing through the day in a one-piece Dress that seems to float around you. The Skirt section is knitted sideways then attached to bodice. It's a delicate Lace Pattern and you will wear it forever. Knitted with Venetia and Glace.



table of contents

KNITTING MAGAZINE — VOLUME 21, NO. 2

	PAGE NO.
584 - WOMENS DRESS	13
585 - WOMENS LACE PULLOVER	14
586 - WOMENS DRESS & COVER UP	15
587 - WOMENS PULLOVER	16
588 - WOMENS EVENING DRESS	17
589 - WOMENS DRESS	18
590 - WOMENS EVENING DRESS	20
591 - WOMENS POLKA DOT TOP & SKIRT	22
592 - WOMENS ANGORA PULLOVER	23
593 - CHILDS JUMPER, BLOUSE & SOCKS	24
594 - WOMENDRESS	25
595 - WOMENS PULLOVER	26
596 - WOMENS TOP & SKIRT	27
597 - WOMENS LEISURE SUIT	29
598 - MENS SWEATER	30
599 - LACE TABLE CLOTH	31
600 - BEDSPREAD WITH PILLOW SHAM	33
601 - WOMENS PULLOVER	35
602A - WOMENS SAILOR DRESS	36
602B - CHILDS SAILOR DRESS	37
603 - WOMENS PULLOVER	39
604 - YOUNG MENS PULLOVER	40
KNITTING NEWS	41

editorial

KNITTING SEMINARS ARE GREAT... There are more and more of them and the skills displayed during them are improving all the time... Seminars are great for the opportunities they afford every knitter not only to learn from the expert demonstrators but for the many new friends they will make and with whom they can exchange knowledge and ideas... Seminars are great for viewing new machines, new accessories and new techniques. Time was when practically all pattern stitch selection was performed manually and long finger nails were an asset in the pulling and pushing of needles, and yarn was fed manually into the machine.

We certainly have come a long way baby!!! Right up to computerized fully programmable machines with Electric Carriages and Motor Drive units, Floppy Disk Drives, R.G.B. Color Monitors for designing original graphics for the permanent retention and repeated use on COMPUKNIT III knitting machines with 200 needle single motif capability... Multi Color Changes, Ribber to Knitter Transfer Carriages... Electronic Seaming Machines, Computers for charting garments to size, etc., etc. There seems no end to the innovations... and how exciting they all are.

There are machines for very fine weight yards, machines for regular weight (to sport weight), yarns and machines for bulky yarns... We remember when machine manufacturers did not think it economically wise to make bulky machines, they did not believe there would be a market for them... The KH 260 Bulky has been our biggest selling machine for almost two years...!! Thereby, confounding the marketing experts.

We remember when there was little to demonstrate at Seminars. When there were only two models of machines, both basically stockinette stitch machines. There was not much to excite students except that even then, they did beautiful knitting at amazing speed. Knitting Fair Isle and Tuck Stitch Designs was a different story. It was slow, tedious and you needed to concentrate intently in order to avoid errors. Lace Designs involved the hand transferring of stitches one needle at a time. Some techniques were enough to turn off all but the most ardent enthusiast.

Thank goodness for the pioneers, it was their enthusiasm and demand for more versatility and simplicity of operation in knitting machines that accounts for the ever increasing sales of the machines of today. Machines that truly have to be seen to be believed and, when demonstrated to potential customers, create a desire in them to own and use.

Yes, Seminars are great... and we encourage you to attend as many as you can irrespective of the sponsors... You will always learn some new skills.

Although many KNITTING dealers around the U.S. sponsor their own Seminars, KNITTING the parent company only runs one a year and it is the Greatest...!! We have the technical 'know how' of the manufacturers of our knitting machines ready to assist, to provide us with their greatest and most skilled operators... All these and more will be teaching and demonstrating at our annual Seminar and Open House... This year it starts September the 14th and runs through the 19th. We promise not only to teach you new things in addition to the old and tried and true things but we will show new products that will amaze and astound you... Please plan to be with us.

588 cover

Thread Lace is news and this elegant evening Dress is truly gorgeous. It is knitted on the COMPUKNIT III MACHINE. Do line it with matching Satin and drape a sash around your waist. Venetia and Mami Rex. Sizes 10 to 16.

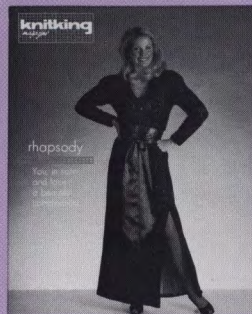

Publisher: KNITTING CORPORATION, 1128 Crenshaw Blvd., Los Angeles, Calif. 90019. Telephone: (213) 938-2079. Published quarterly. Subscriptions: USA—\$18.00 annually, single copies \$5.00; \$21.00 all other countries. The entire contents of KNITTING MAGAZINE are copyright and must not be reproduced in any shape or form without the express permission, in writing, of the publisher.
© COPYRIGHT 1987 KNITTING CORPORATION

601 grandeur

Everyone wants an elegant Angora Sweater and this one is designed to fit almost everyone. It's knitted sideways on a bulky machine using Short Rows. Combine Angora, Glace and Venetia for a sensational effect.



589 classy classic

Look your best and wear this lovely dress for any occasion. The Ribbing detail down the front flatters any figure. It is made with our Venetia yarn.
Sizes 8 to 18.





591 polka dots

flatter and draw attention . . . and this lovely two-piece Dress is a winner. The Top gives you a chance to practice your skill with Intarsia knitting. The Skirt is Stockinette stitch with a slight flare. Knit it with Venetia in sizes 12 to 16.

592 softee blouse

We can't resist the softness of Angora and when it is combined with ribbing in Glace and Mirage, the result is unbelievably beautiful. The trim is a purchased applique. Pearls embellish the neckline and Cap Sleeves. Sizes are small to large.



603 fashion asset

Use your bulky machine to knit this Pullover sideways with a short row design in Angora. Pebble is the main yarn. Bulky Venetia together with Glace is used for the bands. Sizes 12 to 18.



596 rainbow bright

A two-piece Dress with plenty of allure. The Skirt is a full needle rib, the long Topper a Fair Isle Design in rainbow colors. It's knitted on any Electronic machine. Venetia is the yarn. Sizes 10 to 16.



586 span the seasons

Our new yarn Pearlite knits up into a lovely cap sleeve Sheath. A Fair Isle Design with Stockinette stitch insert at neck. The lovely triangle Shawl is an added attraction. Sizes 6 to 14.





602
double
your
pleasure

Two-piece matching sailor Dresses . . . one for Mother and one for Daughter. The Skirts are permanently pleated, the Tops have traditional Sailor Collars with perky bows attached. Our Roma yarn can be machine washed and dried and is perfect for the knitting.

Mother Sizes 6 to 16.
Daughter Sizes 2 to 8.

general instructions



THE PRINTED INSTRUCTIONS

Follow the printed instructions or use them in combination with the Charts. Where there is any question in the instructions, you have the Charts to show you how the section will look.

Be sure to READ AHEAD so that you KNOW what to do for the size you are knitting. In the shapings, where the number of stitches are the same but the number of times different, you might find shapings like this... 3 sts. 1x (2x) [3x]—so that for the first size you will bind off 3 sts. 1x, 2nd size 3 sts. 2x, 3rd size 3 sts. 3x. Sometimes the ROWS will be different for each size—so you must watch out for different row numbers.

Shoulder and neck shapings for the back section of a garment usually are shaped at the same time—so ALWAYS WATCH for the words AT THE SAME TIME.

HOLDING STITCHES ON THE LEFT SIDE WHILE SHAPING THE RIGHT SIDE

There are different ways to hold stitches on one side while completing the other side. Usually, we tell you to bind off the center sts. for neck and put the left side into holding position while completing the right side. The easiest way and really the best way for beginners is to take a piece of RAVEL CORD and hand knit the center neck stitches, pulling them back against the needle bed of machine to the "A" or out of work position. The stitches remain in the HOOKS of the needles so you are really only knitting them HALF WAY. With another color of Ravel Cord, knit the remaining sts. on the left side in the SAME WAY.

It is important to protect these held stitches in some way—so you can either hang a REVERSING BAR so that the EYES of the Bar go BETWEEN the Gate Pegs on the machine and that the UPPER TIPS of Bar only—show above the needle bed...OR the simplest way is to use a piece of 1 inch masking tape and GENTLY place it beneath the knitting—right below the gate pegs. Do NOT press the tape—only enough pressure to hold it in place. This will prevent the Carriage (or Slide) from marking the held section.

It is VERY IMPORTANT that you mark the PATTERN ROW where you divide for the split for NECK (or SHOULDER) shaping.... If you are using a PUNCH CARD—MARK THE CARD—if you are using an ELECTRONIC machine, MARK THE DESIGN WINDOW. Also take note of the Row number for the division. When you are ready to work the left section, bring the HELD stitches back to B (working) position by pulling each end of the Ravel Cord GENTLY and rip it off—be sure to align all needles straight in the B or knitting position.

Now you are ready to REFER TO YOUR OWN INSTRUCTION MANUAL for your machine—to set the controls to begin knitting the left half. The neck stitches can be bound off after completing the right side or you can leave them in hold until each side is finished, then bind them off or remove them onto contrast waste yarn ready to be picked up for knitting a neckband or for other finishing.

FULL FASHION DECREASING OR INCREASING

For Stockinette stitch, use the Full Fashion method for decreasing or increasing (except for regular cap shaping on sleeves where you decrease the edge stitch).

TO DECREASE: Hang the 3rd stitch onto the 2nd stitch then move the end stitches in to fill the empty needle.

TO INCREASE: Move the 2nd end stitches 1 needle outward, then pick up the 3rd stitch from the row below and hang it onto empty needle.

PATTERN SYMBOLS (Code for Symbols on page 13.)

() Symbol for 2nd size.

[] Symbol for 3rd size.

There are up to 3 sizes given for Patterns in KNITTING MAGAZINE. For example, the Charts and printed instructions will show the cast-on as... 124—First size. [132]—Second size. [140]—Third size.

R= ROW

◻ Needles in holding position.

⊗ Needles back into working position.

⊗ For Short Row Knitting

THE SAMPLE SWATCH

Before you knit any garment, you must knit a sample swatch using the yarn you have chosen for your garment. If you do not get the correct Stitch and Row Gauge as given for a Pattern in KNITTING MAGAZINE—try different tensions. If you are using the specified yarn, you should be able to get the correct gauge using a smaller or larger tension. If you are using a different yarn, you may have to make several swatches—but the gauge is very important.

To make a sample swatch—Cast on 60 stitches with waste yarn and knit 6 rows. Mark the tension number for your sample swatch by making holes (you can do this with a Lace Carriage or by hand), 4 transfers for Tension 4, 6 transfers for Tension 6, etc. Knit 6 more rows.

Change to garment yarn and set Counter at 0. Knit 30 rows (in Stockinette stitch or Pattern stitch—according to the garment). With Contrast waste yarn knit the 10th stitch FROM EACH SIDE—by hand. Knit 30 rows. Change to waste yarn and knit 12 rows. Remove the sts. from the machine by pushing the Carriage (or Slide) across without yarn.

Pull and stretch the sample swatch both lengthwise and diagonally from corner to corner, then lengthwise again. Gently block the swatch (KNITTING PRESSING CLOTHS are great for this)—or you can allow the sample to rest several hours or even over night so that the stitches can return to their basic form.

THE KNITTING STITCH/ROW GAUGE and STITCH/ROW CALCULATOR can be used to find the NUMBER OF STITCHES or ROWS TO 1 INCH.

The KNITTING STITCH/ROW GAUGE will give you the NUMBER OF STITCHES or ROWS to 1 inch. After knitting a sample swatch by following our instructions, place the STITCH/ROW GAUGE horizontally with the START LINE on the INSIDE of LEFT stitch mark on sample.

Keep it straight then read the number on the Gauge directly below the inside RIGHT mark on Gauge. This will give you the STITCH GAUGE TO 1 INCH. For instance, if the number is 8, then you have 8 stitches to 1 INCH. To find the ROWS TO 1 INCH, measure from the first row of garment yarn, VERTICALLY to the last row. Read the NUMBER from the LOWER EDGE of GAUGE same as you did for stitches and if the number should be 14, you have 14 rows to 1 inch.

The STITCH/ROW CALCULATOR will now give you the number of sts. or rows needed for a specific measurement. Line the ARROW to the number 8 (8 sts. to 1 inch) and should you need 20 inches of stitches, find the number 20 below and right above the 20 the Calculator shows 160 sts. It works the same way for rows using the Row Gauge.

12 ROWS		12 ROWS
60 ROWS	10 • 40 STS. • 10 ↑ MARK ↑ MARK	30 ROWS 30 ROWS
12 ROWS	oooo TENSION HOLES	CONTRAST YARN 6 ROWS 6 ROWS
60 STS.		

FINISHING

Gently block all sections—For PULLOVERS, JACKETS and DRESSES: Join the front to back at shoulders and sides. Sew sleeves together and set in. Hem lower edge and sleeve edges if needed. For a double neckband or armhole, band sew 1 edge to inside and 1 to the outside of neck or armhole. For a single ribbed band, sew 1 edge to the outside of neck or armhole edge. For a cardigan or jacket with buttonholes, finish buttonholes and sew on buttons.

PANTS: Join front to back at sides. Sew inside leg seams, then join to center front and back. Make hem at waistline and insert elastic. Hem lower edge of pants' legs.



⊗ Needle not used—in out of work position.

3x1

⊗ The number in the box is the number of Rows between shapings. The 3 x 1 above the box gives you the sts. and number of times to make the decreases (or increases)—FOR EXAMPLE: 3 x 1 over the box with 4 means—At the given Row number, *decrease 1 st. knit 4 rows* and REPEAT from * to * 2 times more for a total of 3 times in all. All decreasing (or increasing) WITHOUT ROW NUMBER IN BOX must be made on EVERY 2nd ROW.

584



WOMENS DRESS

SIZES: 10/12 (14/16)
YARN: Bulky Venetia = Col. 1
 Regular Venetia = Col. 2
AMOUNT:
 Col. 1 40 oz. 44 oz.
 Col. 2 9 oz. 9 oz.
TENSION: St. st. T 10+
 Rib. See Instructions
GAUGE: St. st. 12 sts. 18 rows = 2"

Make on any Standard or Electronic machine with Ribber. Trim and Collar are Fisherman Rib.

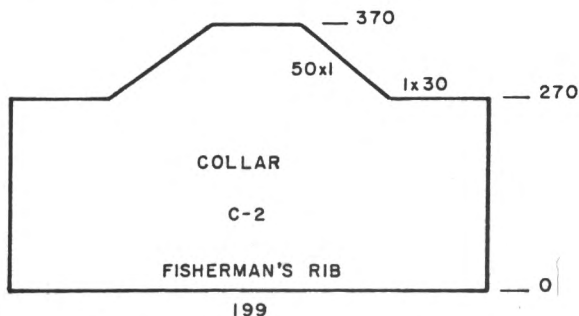

DRESS BACK:

K1, P1 Rib: With Col. 2 cast on 127 (135) sts. After regular selvedge, change ribber setting for Fisherman Rib. Tension 3/3 II. Knit 20 rows. Transfer rib sts. to MB. Add 1 st. on the right. Change to Col. 1 and continue in St. st. with T 10+. After R 178 (182) ON EACH SIDE, dec. 1 st. every 12th row 6x. Then ON EACH SIDE, inc. 1 st. every 8th row 6x but AT THE SAME TIME, after R 276 (280) mark each side with W.Y. for sleeve opening. After R 400 (408), bind off the center 38 (40) sts. Place Ndl. on left to holding position and complete the right side first. *SHAPE SHOULDER AND NECK AT THE SAME TIME. ON NECK EDGE, dec. 1 st. EOR 5x and FOR SHOULDER, bind off or use Short Row Method, 8 sts. 5x (9 sts. 3x, 8 sts. 2x). Bring Ndl. on left back to WP, Row counter back to R 400 (408) and complete the left half. Follow instructions from *.

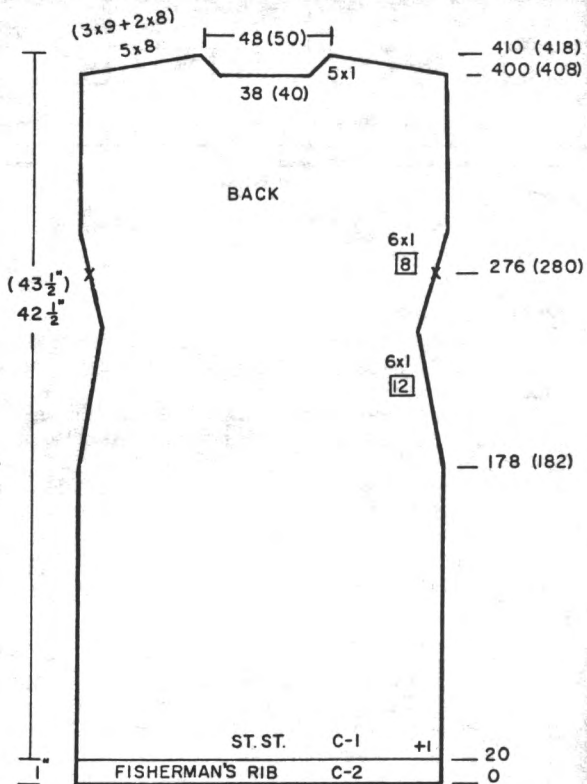

DRESS FRONT:

Work the front the same as back to R 360 (366). SHAPE NECK: Bind off the center 20 (22) sts. place Ndl. on the left to holding position and complete the right side first. *ON NECK EDGE, bind off 1 st. EOR 14x. After R 400 (408) SHAPE SHOULDER SAME AS BACK. Bring Ndl. on left to WP, Row Counter 360 (366) and complete the left half. Follow instructions from *.

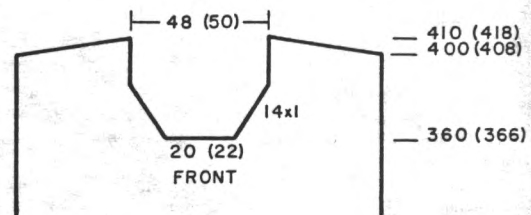

SLEEVES:

K1, P1 Rib: With Col. 2 and T 3/3 II, cast on 163 (171) sts. Hang weights and work ONLY 2 rows Circular for selvedge. (Do not tighten tension for sleeve edge.) Change Ribber setting to Fisherman Rib and knit 14 rows. Transfer Rib sts. to MB. Add 1 st. on the right. Change to Col. 1 and St. st. ON EACH SIDE, dec. 1 st. every 3rd row 42x. After R 154 (158), remove on W.Y.

SLEEVE CUFFS:

Fisherman Rib. With Col. 2, cast on 55 (59) sts. After regular selvedge, change to T 2/2 II. Knit 80 rows. Transfer Rib sts. to MB. With wrong side facing, hang the open sts. of sleeve onto these Ndl. decreasing evenly across. Knit 1 row T 10 over all sts. Bind off.

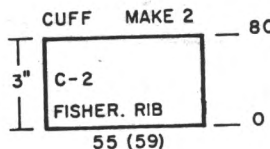
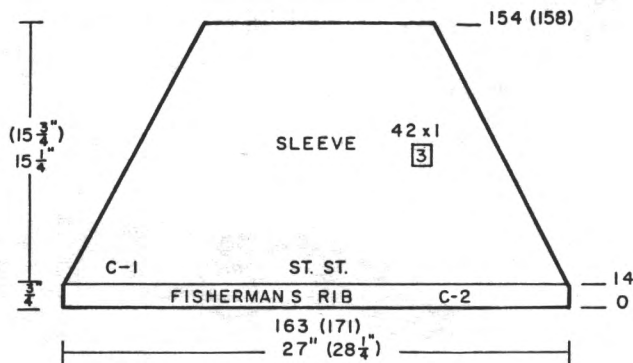

COLLAR INSERT

Fisherman Rib. With Col. 2, cast on 199 sts. After regular selvedge change to T 3/3 II and knit to Row 270. ON EACH SIDE, BO 30 sts. (Transfer corresponding Ribber sts. to MB FIRST). ON EACH SIDE, dec. 1 st. EOR 50x. After R 370, transfer Rib. sts. to MB and BO.

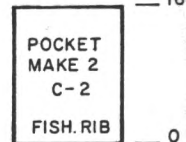

POCKETS: Make 2. 57
 Fisherman Rib: Cast on 57 sts. with Col. 2. Knit 2 rows ONLY FOR SELVEDGE. Change to T 2/2 II and knit to R 160. Transfer Rib sts. to MB. Knit 1 row over all sts. then BO.

FINISHING:

See General Instructions. Join short sides of Collar. Work 1 row single crochet around Neck opening with Col. 1 then work 1 row reverse single crochet. Fold Pocket and pull to form a point. (See Photo). Secure with Button if desired. For positioning of Pockets, allow approximately 17" up from hem for lower edge of pocket and approx. 1 1/2" to 2" from side seam.

585



WOMENS LACE PULLOVER

SIZES: One size fits 6 to 20
YARN: Roma
AMOUNT:
 Col. 1 8 oz.
 Col. 2 8 oz.
 Col. 3 8 oz.
TENSION: Lace Pattern T 4
 K1, P1 Rib. 0/0 II
GAUGE: Lace 14 sts. 18 rows = 2"

Make on any Standard or Electronic machine with Lace Carriage and Ribber. Make Punch Card or draw on Mylar Sheet. 930 machine owners use Pat. 104 from Pattern Book.

BACK:

K1, P1: With Col. 1, cast on 179 sts. Knit to R 70. Transfer Rib sts. to MB then pick up first row to form hem. Add 1 st. on the right side. Knit 2 rows, then begin Lace Pattern BUT AT THE SAME TIME ON EACH SIDE, dec. 1 st. EOR 40x, then 1 st. EVERY ROW 49x. After R 200, ON EACH SIDE, inc. 1 st. EOR 65x. After R 330, bind off.

FRONT:

Work the Front the same as back to R 290. Bind off the center 30 sts. With a RAVEL CORD, knit the sts. on Left back to A (out of work) position. Complete right side first. *ON NECK EDGE, dec. 1 st. EOR 15x. After R 330 bind off remaining sts. or remove on W.Y. Carefully bring the sts. on left to working position (in the hooks of ndls). Turn Row Counter back to R 290 and complete the left half. Follow instructions from *.

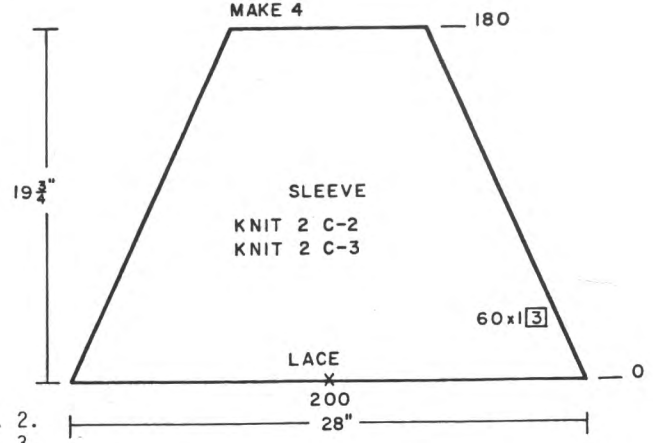

SLEEVES: Make 2 Col. 2.
 2 Col. 3.

W.Y. cast on 200 sts. After several rows, end with 1 row Ravel Cord to the right. Change to garment yarn. Counter 0. 'e' CAST ON over the Ravel Cord row. Knit 2 rows then begin Lace Pat and AT THE SAME TIME, ON EACH SIDE, dec. 1 st. every 3rd row 60x. After Row 180, remove the sts. on W.Y. When you have completed all 4 sections of sleeves, join two same color sections on one side then join other two sections. See Picture.

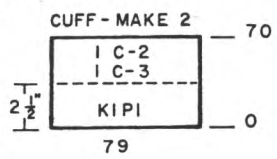

SLEEVE CUFFS: Make 2

K1, P1 Rib: With Col. 2 cast on 79 sts. Knit to R 70. Transfer Rib sts. to MB then pick up first row to form hem. With WRONG side facing, hang the open sts. of sleeve onto these Ndls. decreasing evenly across. MANUALLY knit 1 row across all sts. Bind off. REPEAT for second Cuff but use Col. 3.

ASSEMBLY DIAGRAM

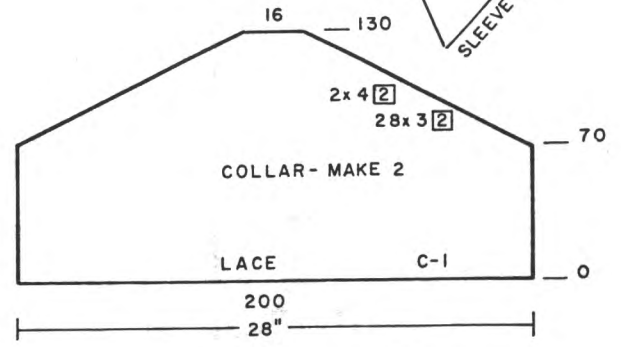
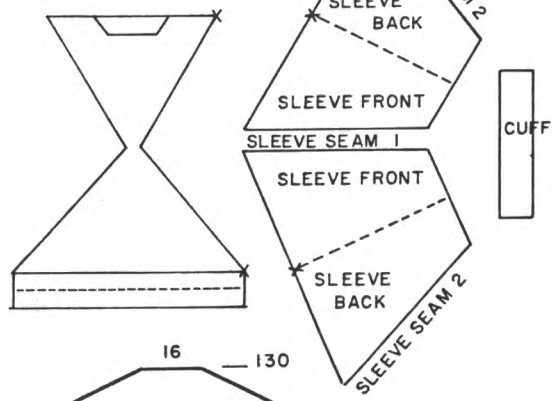

COLLAR: Make 2 sections.

W.Y. cast on same as you did before 200 sts. After Ravel Cord Row, with Col. 1, 'e' cast on. Knit 2 rows then begin Lace Pat. After R 70, ON EACH SIDE, BO 3 sts EOR 28x then 4 sts. EOR 2x. After R 130, bind off remaining sts. After completing second section, join the 2 pieces together along the cast on edge with right sides together. Join LEFT and RIGHT SIDES together (Rows 0 to 70). Leave edges from Row 70 to 130 open.

FINISHING:

Close shoulder. Attach Collar.

Repeat Punchard thru Row 53. Then Punch 2 Rows for connecting Card.

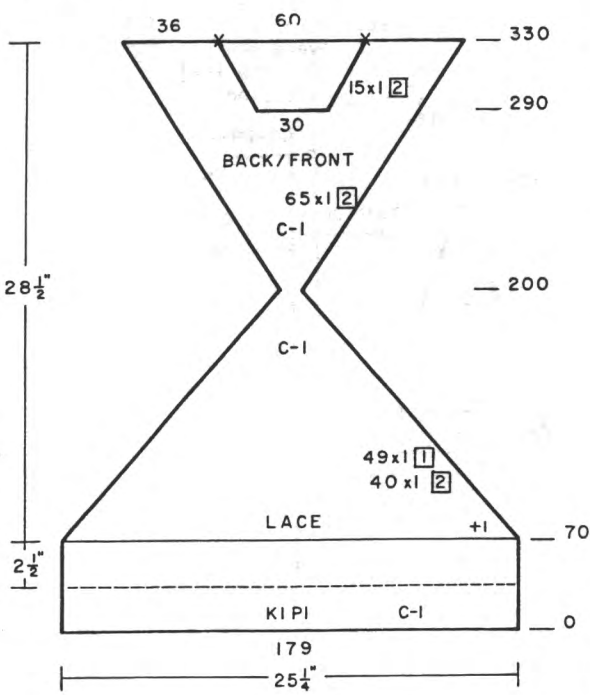
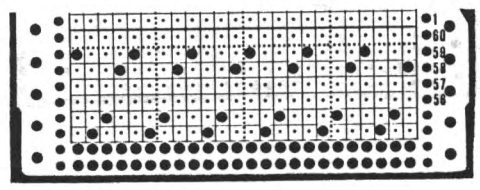



WOMENS DRESS & COVER-UP

SIZES: 6/8 (10/12) [14]

YARN: Pearlite

AMOUNT:

Col. 1 27 oz. 28 oz. 32 oz.
Col. 2 27 oz. 28 oz. 29 oz.

TENSION: Fair Isle T 4, FNR 2/2 II

GAUGE: 15 sts. 20 Rows = 2"

Make on any Standard Punch Card or Electronic Machine with Ribber.
A Fair Isle Design and St. st.

BACK:

FNR: With Col. 1, cast on 124 (130) [136] sts. After regular selvedge, knit 20 rows. Transfer Rib sts. to MB and knit 1 row to the left. SET PATTERN and knit 1 row to the right to select Ndl's. Add Col. 2 and continue in Fair Isle Design. ON EACH SIDE, inc. 1 st. every 10th row 14 (15) [16]x.
After R 202 (208) [214], ON EACH SIDE, decrease 1 st. every 8th row 10x.
After R 282 (288) [294] [300], ON EACH SIDE, increase 1 st. every 6th row 10x.
After R 432 (442) [452] Mark Neck Opening with W.Y. then BO or remove on W.Y.

FRONT:

Work the front the same as back to R 328 (330) [340]. Divide in center for 'V' Neck opening. Place Ndl's. on left to HP and complete the right side first. Mark Pattern row on Pucnh Card or Mylar Sheet so you will know where to begin on the left side.*Continue side inc. ON NECK EDGE, dec. 1 st. every 4th row 26 (28) [1 st. every 4th row 23x, 1 st. every 3rd row 7x].
R 432 (442) [452], BO or

remove on W.Y.

Bring the Ndl's. on left to WP. Turn Row Counter back to 328 (330) [340] SET PATTERN TO MARKED ROW ON CARD OR MYLAR SHEET and BE SURE TO SELECT NEEDLES and then continue in Fair Isle Design follow instructions from *.

NECK INSERT:

FNR: With Col. 1, cast on 60 (64) [68] sts. After regular selvedge, with T 2/2 II, knit 10 rows. Transfer Rib sts. to MB and continue in St. st. and AT SAME TIME, ON EACH SIDE, dec. 1 st. every 5th row 18x (1 st. every 4th row 14x, 1 st. every 5th row 8x) [1 st. every 4th row 20x, 1 st. every 5th row 10x]. After R 136 (140) [144], bind off remaining sts.

NECK INSERT

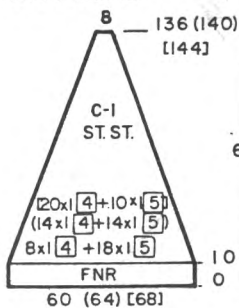

COVER-UP

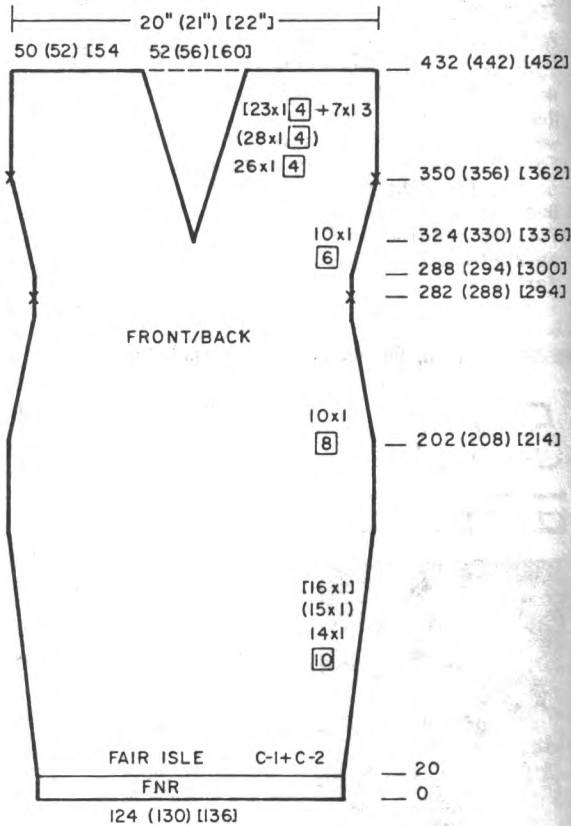
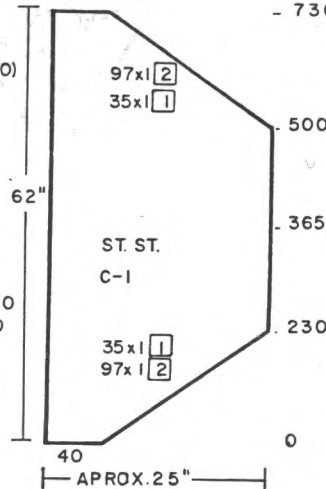

NECK TRIM: Make 1.

With Col. 2, 'e' cast on 8 sts. Continue in St. st. to R 314 (324) [334]. Bind off. JOIN BOTH SHOULDERS. Fold Neck Trim lengthwise and beginning at one shoulder seam, sew to Neck Opening by hand. Join Neck Insert to neck opening in the same way.

NECK TRIM MAKE 1



SLEEVE BANDS

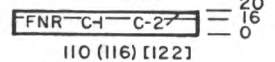

SLEEVE BANDS: Make 2.

FNR: With Col. 1, cast on 110 (116) [122] sts. After regular selvedge, knit 16 rows. Change to Col. 2, knit 4 rows. Transfer rib sts. to MB and knit 1 row over all sts. With wrong side facing, hang armhole onto these Ndl's. Bind off loosely.

COVER-UP

Starting at Ndl. 40 to the LEFT OF 0, with Col. 1, 'e' cast on over 40 Ndl's. Hang weights and continue in St. st. ON THE RIGHT SIDE, inc. 1 st. EOR 97x, 1 st. EVERY ROW 35x. After R 230, knit straight to R 500. ON THE RIGHT, dec. 1 st. EVERY ROW 35x, 1 st. EOR 97x. After R 730, bind off remaining sts.

FINISHING:

See General Instructions. With Col. 1 work 1 row single crochet around edges of Cover-up then using 1 strand Col. 2 and 1 strand Gold Metallic, *work 3 single crochets, chain 3, single crochet in last single crochet, Chain 2, and REPEAT from * around.

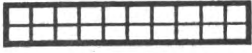

WOMENS PULLOVER

SIZES: 10/12 (14/16) [18/20]
YARN: Amore
AMOUNT:
 Col. 1 8 9 10 Balls
 Col. 2 2 2 2 Balls
TENSION: St. st. 7. Neckband ONLY 5.2
GAUGE: 14 sts. 23 rows = 2" (5 cm)

Make on any Electronic machine. Body of garment is Stock. st. Trim is a Fair Isle Design. KH 930 machine owners use Pat. 9 from Pat. book. Other machine owners, mark Mylar Sheet.

BACK:

Waste Yarn cast on 162 (172) [182] sts. After several rows, end with 1 row Ravel Cord to the left. Change to Col. 1, Counter 0. Continue in St. st.
 After R 142 (146) [150], mark each side with W.Y. for armhole.
 After R 226 (238) [250], SHAPE NECK: BO center 42 (46) [50] sts. Put sts. on left to holding position and complete the right side first.
 *ON NECK EDGE, dec. 1 st. EOR 10x.
 After R 246 (258) [270], bind off or remove on WY.
 Bring the sts. on left back to WP, Row Counter 226 (238) [250] and complete left half. Follow instructions from *.

FRONT:

Cast on same as back and knit to R 136 (144) [152]. Divide in Center for V neck shaping. Place sts. on left to holding position and complete right side first.
 *ON NECK EDGE, dec. 1 st. every 3rd R 31 (33) [35]x BUT AT THE SAME TIME, after R 142 (146) [150] ON EACH SIDE, mark for Armhole with bit of WY. After R 246 (258) [270], BO or remove on WY.
 Bring sts. on left back to WP. Turn Row Counter back to 136 (144) [152] and complete left half. Follow instructions from *.

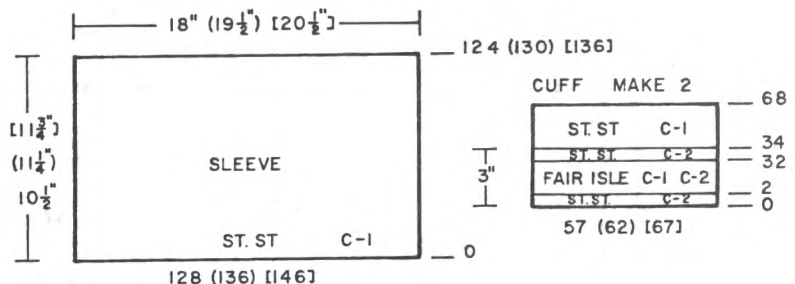

SLEEVES: Col. 1
 WY cast on 128 (136) [146] sts. same as before. Knit to R 124 (130) [136]. Remove on WY.

WAIST BAND MAKE 2

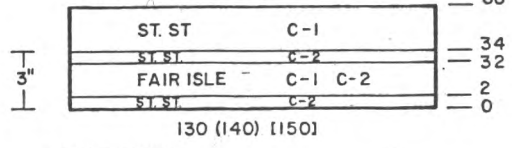

WAIST BANDS:

WY cast on 130 (140) [150] sts. same as before. Change to Col. 2, knit 1 row. Set Fair Isle Pat. 930 machine owners use Pat. 9. PRESS VARIATION BUTTON NO. 5 (upside down button).
 With Col 1 in Feeder A and Col. 2 in Feeder B, continue in Fair Isle Pat. After R 32, cancel Pat. With Col. 2, knit 2 rows. Change to Col. 1 and continue St. st.
 After R 68, pick up first row to form hem. With wrong side facing, hang the open sts. from Back/Front onto these Ndl. decreasing evenly across. Bind off LOOSELY.

SLEEVE CUFFS:

WY cast on 57 (62) [67] sts. same as before. Change to Col. 2 and knit same as Waist Band. (Be sure to use No. 5 Variation Button).
 After forming hem, hang open sts. of Sleeve edge onto these Ndl. decreasing evenly across. Bind off.

NECK BAND MAKE 2

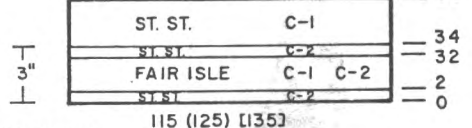

NECKBAND:

Join shoulders of front and back. Bring 115 (125) [135] ndls. to WP. WITH WRONG SIDE FACING, hang one half of the Neck opening onto these Ndl. Start at center back and end at point of 'V'. Do not Use Variation 5.
 With color 2, knit 2 rows, setting Pat. on 2nd row. With Col. 1 and 2, continue in Fair Isle Pattern.
 After R 32, STOP PAT. change to Col. 2, knit 2 rows. Change to Col. 1 and knit to Row 68. Pick up first row to form hem and bind off LOOSELY.

FINISHING:

See General Instructions.

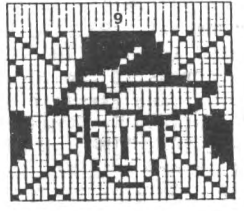
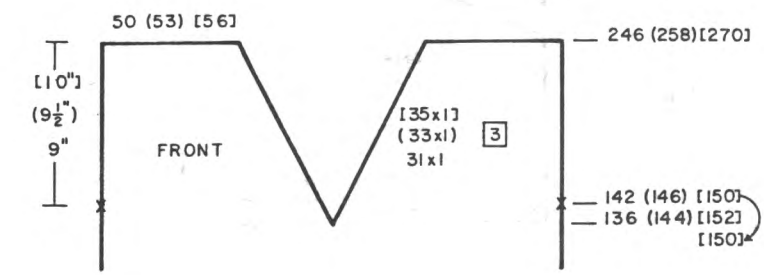
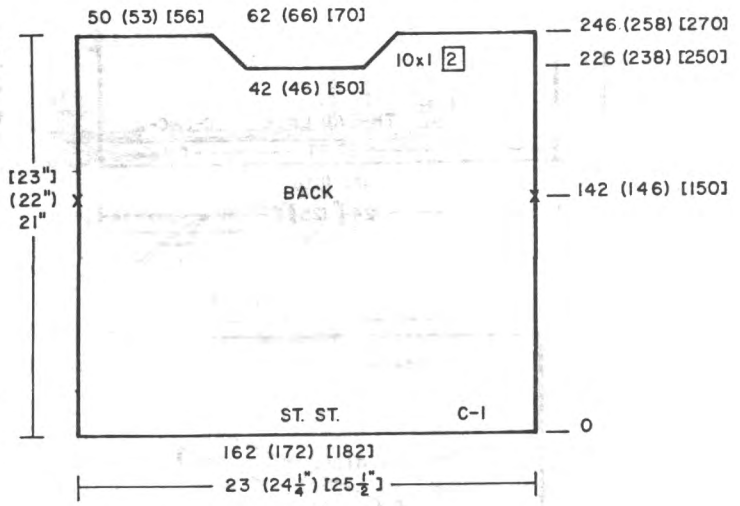



WOMENS EVENING DRESS

SIZES: 10/12 (14/16)
YARN: Venetia = Color 1
 Soft Mami Rex = Color 2
AMOUNT:
 Col. 1 32 oz. 36 oz.
 Col. 2 8 Spools all sizes.
TENSION: Thread Lace T 10
GAUGE: 13 sts. 16 rows = 2" (5 cm)

Make on the KH 930 using Thread Lace Pattern No. 397. Trim is St. st. Purl side is right side.

BACK SKIRT:

W.Y. cast on 162 (170) sts. After several rows, end with 1 row Ravel Cord to the right. Counter 0. Change to Col. 1. T 5. Knit 8 rows. Pick up first row of garment to form hem. Bring all Ndl. to 'E' (holding) position then knit 1 row to the left. PROGRAM PAT. 397 using Sel. 1. T 10. Knit in Thread Lace Pattern to R 326 (336). Remove on W.Y.

BODICE:

Bring 118 (126) Ndl. to working position. Hang open sts. of Back Skirt onto these Ndl. decreasing evenly across. With Carr. on far left (outside sensor) program Pat. 397. Push in both part buttons (NO YARN IN FEEDER) and move Carr across to the right to select Ndl. Place yarns in Yarn Feeders and continue in Thread Lace Pat. BUT AT THE SAME TIME, ON EACH SIDE, inc. 1 st. every 10th row 6x. After R 66 (70) SHAPE ARMHOLE: ON EACH SIDE, BO 5 (6) sts 1x, 4 (5) sts. 1x, 4 sts. 1x, 3 sts. 1x, 2 sts. 1x, 1 st. 3x. After R 136 (144), with contrast waste yarn, mark for Neck opening and BO or remove on W.Y.

SKIRT FRONT:

W.Y. cast on same as back skirt. 135 (140) sts. T 5.- Col. 1. Knit 8 rows. Pick up first row to form hem same as before. Knit 1 row then Program Pat. 397 and begin Thread Lace Pattern as before with T 10. After R 326 (336), remove on contrast waste yarn.

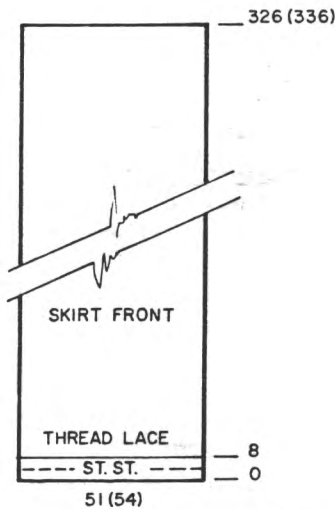

NARROW SKIRT FRONT:

W.Y. cast on same as you did before - 51 (54) sts. Work the same as other skirt sections to R 326 (336) then remove on W.Y.

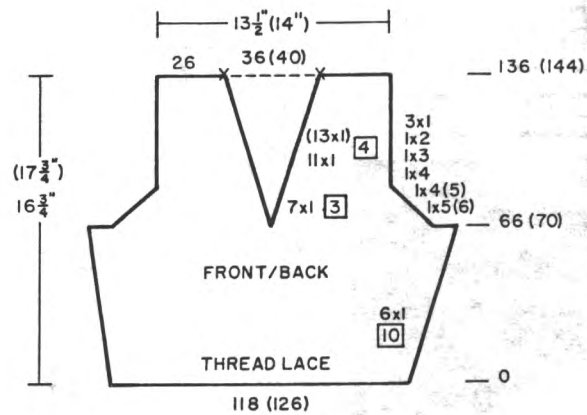
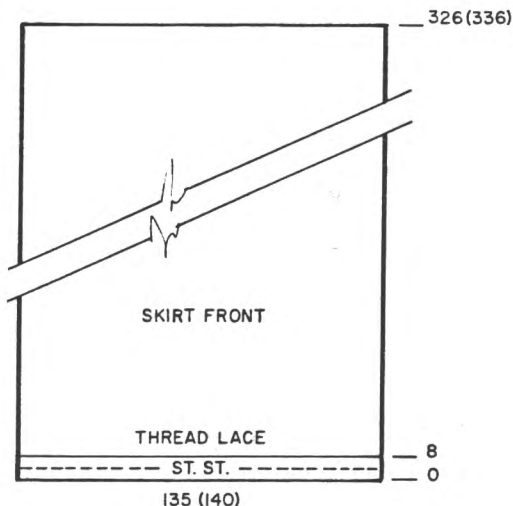
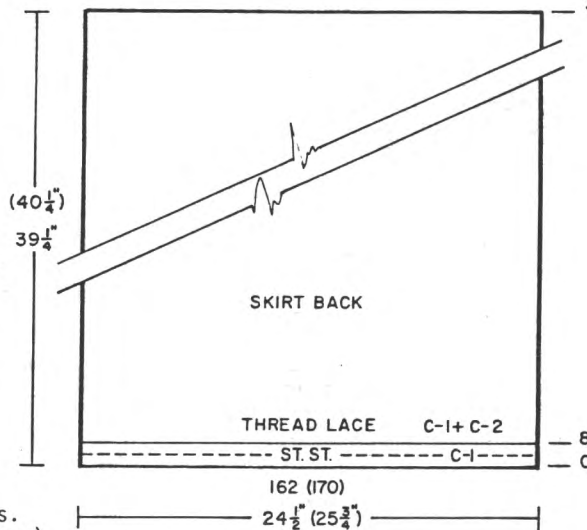

FRONT BODICE:

Bring 118 (126) Ndl. to WP. With PURL SIDE FACING and beginning at far right, hang open sts. of NARROW Front Strip onto these Ndl., then hang wider Front strip in same manner but OVERLAP ACROSS NARROW STRIP for approx. 3 inches. Distribute the remaining sts. evenly across.

PROGRAM PAT. 397 and with Carr. on the far left and NO YARN IN FEEDERS, PUSH IN BOTH PART BUTTONS and select Ndl. from left to right. Work the same as before BUT AT THE SAME TIME, ON EACH SIDE, inc. 1 st. every 10th row 5x.

After R 66 (70), divide in the center for Neck opening. PRESS M to memorize Row Number SHAPE NECK AND ARMHOLE AT THE SAME TIME. LEFT SIDE IN H*FOR NECK, bind off 1 st. every 3rd row 7x, 1 st. every 4th Row 11 (13)x. FOR ARMHOLE, decrease same as back bodice.

After R 136 (144) bind off or remove on W.Y.

PUSH M KEY. Bring all the Ndl. to WP (IN HOOKS OF NDLS.) Row Counter 66 (70) and complete the left half. Follow instructions from * and if you do not know how to begin knitting the left half, GO TO PAGE 122 of the KH 930 Instruction Manual.

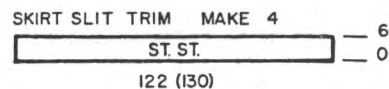

TRIM FOR SKIRT SLIT: Make 4.

Bring 122 (130) Ndl. to WP. With KNIT SIDE FACING, hang HALF the length of the slit onto these Ndl. T 5, Col. 1. Knit 6 rows. Pick up first row to form hem. Bind off. REPEAT FOR 2nd HALF OF SKIRT PANEL. Make Trim in the same way for second section of Skirt.

SLEEVES:

W.Y. cast on 48 (54) sts. same as before.
 Change to Col. 1 T 5. Knit 8 rows.
 Pick up first row to form hem. Knit
 1 row to the left. PROGRAM PAT. 397
 and knit to the right to select Ndl's.
 T 10. Continue in Thread Lace Pat.
 ON EACH SIDE, inc. 1 st. every 5th
 row 22 (28)x.
 After R 154 (158) SHAPE CAP: ON
 EACH SIDE, BO 5(6) Sts. 1x, 4 Sts. 1x,
 1 st. every 4th row 12 (13)x.
 After R 206 (214), BO remaining sts.

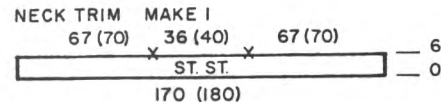
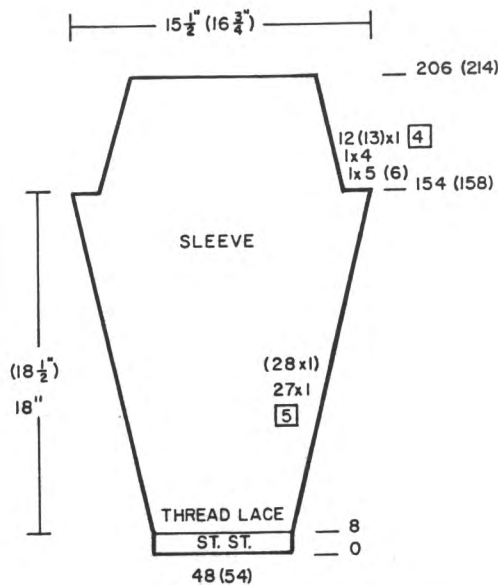

NECK TRIM: Make 1.

With Col. 1, 'e' cast on LOOSELY
 170 (180) sts. T 5. Knit 6 rows
 St. st. Pick up first row to
 form hem. See Chart and mark with
 W.Y. for back Neck and sides of V.
 Knit 1 Row and Bind Off.

FINISHING:

See General Instructions.
 Sleeve is slightly puffed so
 ease to fit or gather slightly
 around top of sleeve cap.
 Join Neck trim and sew to Neck
 edge, overlapping at point of V.

589

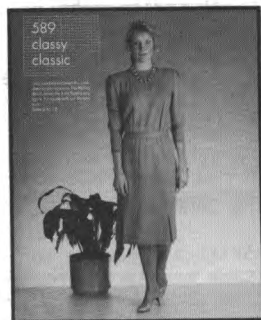

WOMENS DRESS

SIZES: 8/10 (12/14) [16/18]
 YARN: Venetia
 AMOUNT: 26 oz. 27 oz. 28 oz.
 TENSION: St. st. 4.2
 GAUGE: 17 sts. 23 rows = 2"

Make on any Standard Machine.
 Casing is FNR.

SKIRT FRONT PLEAT SECTIONS:

Make 1, reverse 1

NOTE: The pleat sections have
 an inner fold line which is a
 needle out of work and an outer
 fold line made by placing the
 specified needle to holding po-
 sition for 1 row then returning
 it to work on the next row.
 Set Cam to hold needles and
 you must push this needle back
 to work by hand on every 2nd
 row.

W.Y. Cast on 55 (59) [63] sts.
 After several rows end with 1 row
 Ravel Cord to the right.
 Counter 0. Change to Garment yarn.
 Counting from the right side
 (left for 2nd section), place
 15th st. to the out of work
 position. The 22nd st. will
 be the outer fold st.

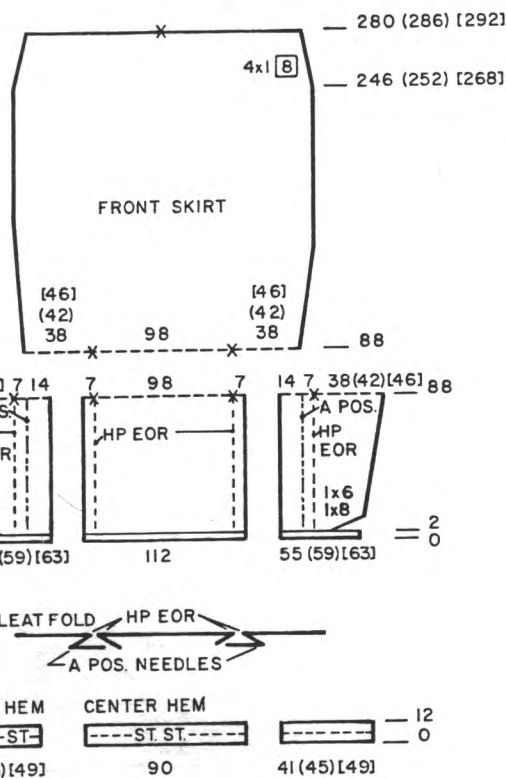

CENTER PLEAT SECTION: Make 1.

W.Y. cast on same as before.
 112 sts. After Ravel Cord
 row, change to garment yarn.
 Counter 0. Work the OUTER
 FOLD ST. ON NEEDLE 8 ON EACH
 SIDE.
 After R 88, remove each section
 on separate W.Y. (see Chart).
 JOIN SIDE SECTIONS TO CENTER
 SECTION.

SKIRT FRONT HEM:

SIDE PANELS: Make 2. Bring 41
 (45) [49] Ndl's. to WP. With wrong
 side facing, hang open sts. of one
 side section onto these Ndl's de-
 creasing evenly across.
 Knit 12 rows. Pick up first row
 to form hem and BO.
 REPEAT FOR OTHER SIDE PANEL.

CENTER PANEL: Bring 90 Ndl's. to WP.
 With wrong side facing, hang open
 sts. of center panel onto these
 Ndl's, decreasing evenly across.
 Knit 12 rows. Pick up first row
 to form hem and BO.

SKIRT FRONT:

After the pleat sections have
 been joined together, bring
 to WP 174 (182) [190] Ndl's.
 With WRONG SIDE FACING, and
 beginning on the LEFT, hang the
 joined pleat sections onto these
 Ndl's as follows:
 Hang the first 38 (42) [46] sts.
 then FOLD the next 7 sts. to form
 pleat
 Hang the center section on
 98 Ndl's. FORMING THE PLEATS as
 shown on the Chart ON EACH SIDE.
 Hang the next pleat section in
 the same way as you did before
 making the pleat OPPOSITE from
 first pleat. The Chart will
 make it easier for you to see
 what is to be done.
 Counter 88. Continue in St. st.
 to R 246 (252) [268].
 ON EACH SIDE, dec. 1 st. every
 8th row 4x.
 After R 280 (286) [292], remove
 onto W.Y. Mark center st. first.

Knit 2 rows then begin the holding
 of the 22nd st. for 1 row, push
 it back on the next row (See
 Chart and above instructions).
 AT THE SAME TIME, ON OPPOSITE
 SIDE OF CARR. after Row 1
 (Carr. is on the left), bring
 to HP 14 sts. 1x. On every
 2nd row, bring back to WP
 8 sts. 1x, 6 sts. 1x.
 Continue in St. st. remembering
 the fold line and AT THE SAME
 TIME, on OUTSIDE EDGE (see Chart)
 inc. 1 st. every 15th row 10x.
 After R 88, remove 22 sts. on
 W.Y. then remove 38 (42) [46] sts.
 on W.Y.
 REVERSE SHAPING for 2nd section.

CONTINUED..

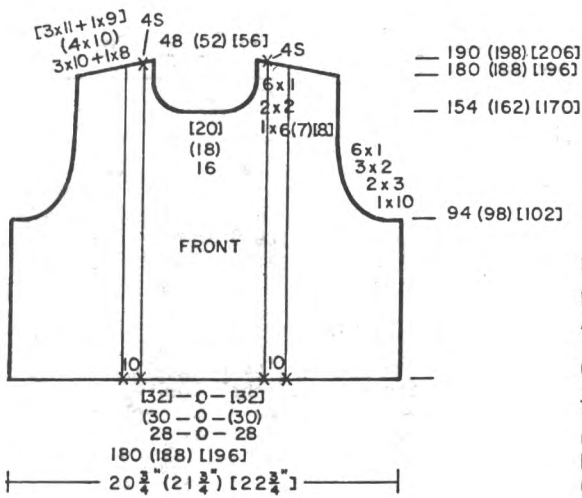

FRONT BODICE:

NOTE: The Cable Design on the front bodice is made by dropping the specified stitches and manually latching them up to a knit st. then when this is completed, the mock cable is made by pulling the sts. together in center and tacking it on the inside. While you are knitting, it is a good idea to mark every 20 rows with W.Y. in the center of mock cable.

Bring 180 (188) [196] Ndl. to WP. W.Y. cast on same as before. After Ravel Cord row, change to garment yarn and Counter 0. ON EACH SIDE OF 0, mark Ndl. 28 (30) [32].

Continue St. st. to R 94 (98) [102]. SHAPE ARMHOLE: ON EACH SIDE, bind off 10 sts. 1x, 3 sts. 2x, 2 sts. 3x, 1 st. 6x. After R 154 (162) [170] bind off the center 16 (18) [20] sts. place the sts. on the left to HP and complete the right side first. *ON NECK EDGE, bind off 6 (7) [8] sts. 1x, 2 sts. 2x, 1 st. 6x, BUT AT THE SAME TIME, after R 179 (187) [195], SHAPE SHOULDER using the short row method. 10 sts. 3x, 8 sts. 1x (10 sts. 4x) [11 sts. 3x, 9 sts. 1x]. REMOVE THE SHOULDER STS. ON W.Y. Bring the Ndl. on left to WP turn Counter back to 154 (162) [170] and complete the left half. Follow instructions from *.

BACK BODICE:

W.Y. cast on same as before 172 (180) [188] sts. After Ravel Cord row, change to garment yarn. Counter 0. Knit to R 12 (20) [28]. Place sts. to the LEFT OF 0 in holding position or you can remove them onto W.Y. and complete the right side first.

After R 94 (98) [102], SHAPE ARMHOLE: Bind off 10 sts. 1x, 2 sts. 3x, 1 st. 8x, 1 st. every 4th row 4x. After R 179 (187) [195], SHAPE SHOULDER using Short Rows. 9 sts. 3x, 7 sts. 1x. (9 sts. 4x) [10 sts. 3x, 8 sts. 1x]. Remove the shoulder sts. and neck sts. separately on W.Y. Bring Ndl. (or rehanging sts.) to WP. Counter 12 (20) [28] and complete the left half, reversing armhole and shoulder shaping.

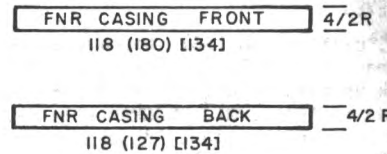
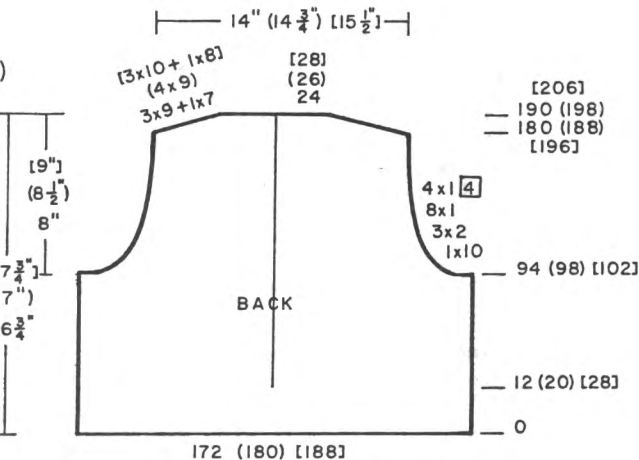
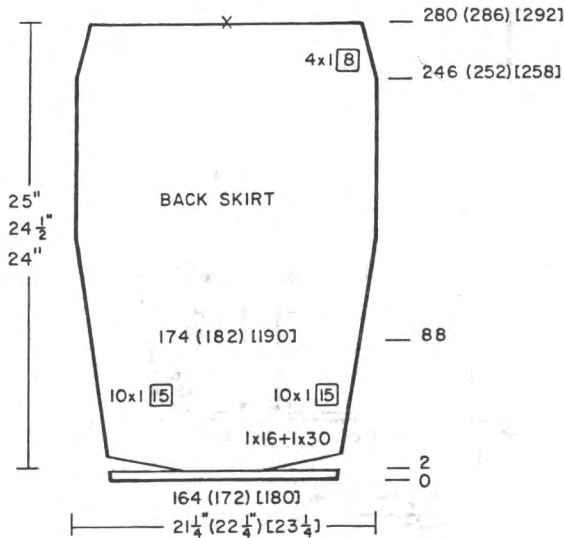

CASING:

Bring 118 (127) [134] Ndl. to WP. Hang open sts. of skirt onto these ndls. as follows:

Starting from left and right, count in toward center 10 (11) [12] sts. Place the next 3 sts. together on next ndl. Count 10 (11) [12] sts. place the next 3 sts. together on next ndl. Count 10 [11] [12] Ndl. place next 4 sts. together on next ndl. etc. across to center. Bring Ribber to working position. Pitch H. Bring up ndls. to form FNR.

Knit 1 row from right to left to form zig-zag Hang Comb and weights. Knit 4 rows.

ON MAIN BED ONLY. Change controls and knit 2 rows ON RIBBER ONLY. Transfer rib sts. to MB, knit 1 row. Remove on W.Y.

Bring 118 (127) [134] ndls. to WP. With KNIT SIDE FACING, hang open sts. of front bodice onto these ndls, decreasing evenly across. With WRONG SIDE FACING, hang open sts. of casing onto these same ndls. Bind off.

MAKE BACK CASING SAME AS YOU DID FOR THE FRONT. Join the Back Skirt and Bodice to the casing in same manner as front.

SKIRT BACK HEM:

Bring 126 (134) [144] Ndl. to WP. With wrong side facing, hang open sts. of lower skirt onto these ndls. decreasing evenly across. Knit 12 rows. Pick up first row to form hem and BO.

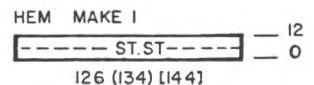

SLEEVES:

W.Y. cast on same as before 60 (70) [74] sts. After Ravel Cord row, change to garment yarn. Counter 0. Continue in St. st. ON EACH SIDE, increase 1 st. every 6th row 23x. After R 162 (166) [170], ON EACH SIDE, SHAPE CAP: Bind off 10 sts. 1x, 1 st. every 3rd row 4x, 1 st. every 4th row 3x, 1 st. every 6th row 6x, 1 st. every 4th row 6x, 1 st. EOR 5x, 2 sts. 2x. After R 254 (262) [270], bind off remaining sts.

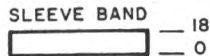

SLEEVE BANDS:

50 (53) [56]

Bring 50 (53) [56] Ndl. to WP. With wrong side facing, hang open sts. of lower sleeve edge onto these Ndl., decreasing evenly across. Knit 18 rows. Pick up first row to form hem. Bind off.

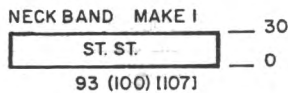

NECKBAND:

Close one shoulder. NOTE: There will be 4 extra sts. on front Bodice shoulders because of the mock Cables. Distribute these sts. evenly across the 10 Mock Cable sts. BEFORE CLOSING SHOULDER, with PURL SIDE (wrong side) facing, working from SHOULDER EDGE, count 27 sts. then one at a time, drop the next 2 sts. and latch them up into a knit st. all the way down front. leave 1 purl st. and latch the next 4 sts. up one at a time. Leave 1 purl st. and drop the next 2 one at a time and latch up these sts. Do the same on other front side of bodice. Bring 93 (100) [107] Ndl. to WP. With wrong side facing, pick up sts. around neck edge evenly. Knit 30 rows. Pick up first row to form hem and bind off.

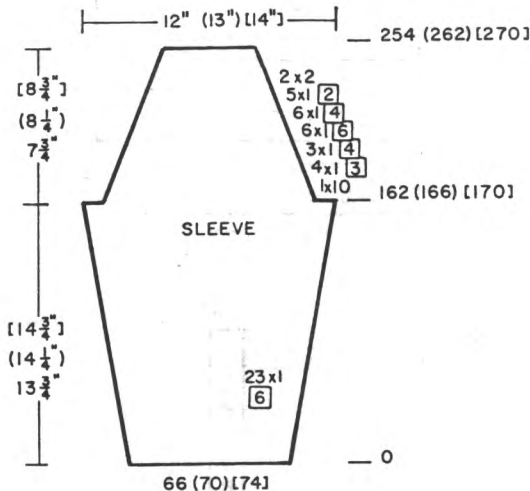

BELT:

Set machine for FNR. See Chart for needle arrangement. After regular selvedge, change to T 5/4.1 II and continue in FNR to desired length.

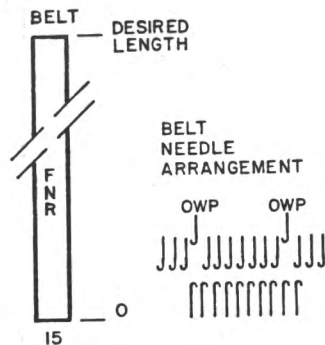

FINISHING:

See General Instructions. On the front bodice where you have marked every 20 rows, pull the sts. together with yarn threaded in tapestry needle. Secure on the inside. This forms the Mock Cable.

590



BACK:

FNR: Cast on 164 (174) [182] st. with Col. 1. After Regular selvedge knit 14 rows. Transfer Rib sts. to MB and continue in St. st. Knit 2 rows over all sts. then work SHORT ROWS: ON OPPOSITE SIDE OF CARR. Bring to HP 40 sts. before knitting the next 2 rows. ON OPPOSITE SIDE OF CARR. bring back to working position 10 sts. 4x ON EACH SIDE. (ALWAYS WRAP THE INSIDE NDL. IN HP to prevent holes when knitting Short Rows). ON EACH SIDE, dec. 1 st. every 50th row 6 (7) [7]x AND AT THE SAME TIME, after R 200, mark the right edge with W.Y. for side slit. After R 368 (376) [384], dec. 1 st. every 10th row 6x. After R 496 (506) [516], knit 1 row T 10. Return to garment tension and knit to R 520 (530) [540]. Pick up the LOOSE marked row to form hem and bind off.

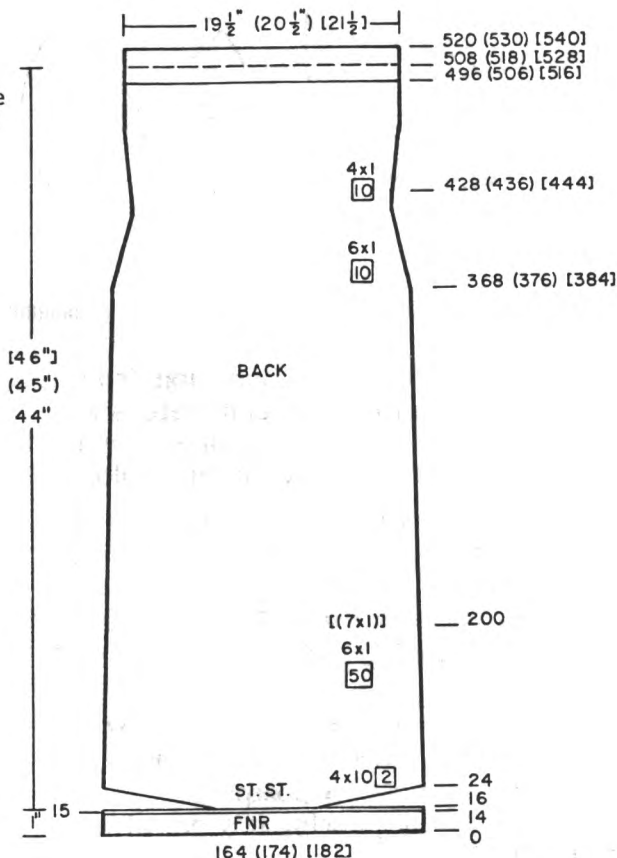

WOMENS EVENING DRESS

SIZES: 6/8 (10/12) [14/16]

YARN: Std. Venetia = Col. 1
Papillon = Col. 2

AMOUNT: Col. 1 24 oz. 26 oz. 28 oz.
Col. 2 1 Cone for all sizes.

TENSION: St. st. 5, FNR 5/5 II

GAUGE: 15 sts. 22 Rows = 2"

NOTIONS: Hook and Eye for Belt

Make on any Standard or Electronic machine with Ribber. Stockinette stitch with FNR for Bands.

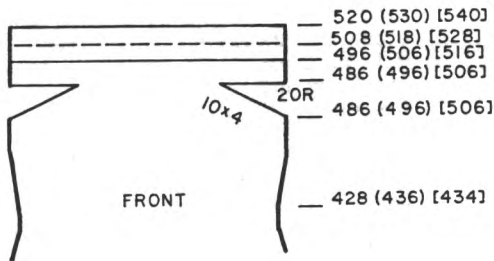

FRONT:

Work the front the same as back to R 486 (496) [506] then work Short Rows for BUST DART and DO NOT COUNT THESE ROWS. ON OPPOSITE OF CARR. bring to HP 10 sts. 4x ON EACH SIDE. ON OPPOSITE OF CARR. bring all Ndl. to WP before knitting next 2 rows and continue same as back.

Side Bands for Slit Opening Make 2

FNR: With Col. 1, cast on 110 sts. After regular selvedge, knit 10 rows. Transfer Rib sts. to MB. Knit 1 row. Remove on W.Y. Bring 110 Ndl. to WP. With right side facing, hang 1 edge of slit onto these Ndl. Hang slit facing held on W.Y. onto these Ndl. with WRONG SIDE FACING. Bind off LOOSELY. REPEAT for second side of slit.

ROSETTE DIAGRAMS

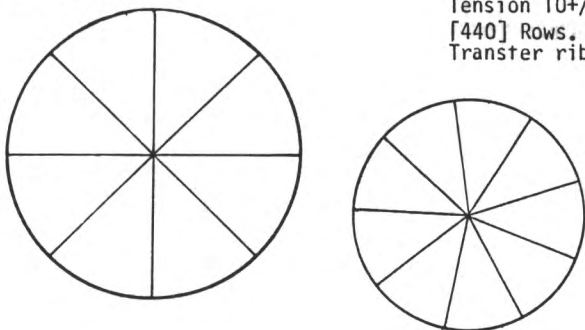

SHOULDER STRAP MAKE 1

FNR	C-1	6
		0
		80
ST. ST.	C-2	70
	C-1	64
	C-2	54
	C-1	48
	C-2	38
	C-1	32
	C-2	22
	C-1	16
ST. ST.	C-2	6
FNR	C-1	0

118 (120) [122]

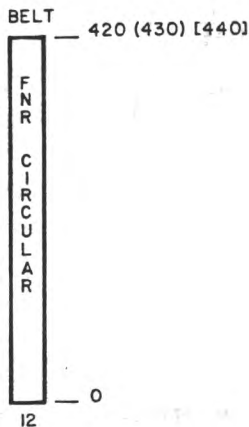
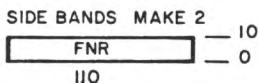

BELT:

FNR: With Col. 2, cast on 12 sts. Set for circular knitting and with Tension 10+/10+ I, knit 420 (430) [440] Rows. Transfer rib sts. to MB and Bind off.

SHOULDER STRAP

FNR: With Col. 1, cast on 118 (120) [122] sts. T 5/5 II. Knit 6 rows. Trans: rib sts. to MB. Col. 2 Tension 10+ St. st. Knit 10 rows. Change to T 5, knit 6 rows. Continue to follow Chart for Col. changes to R 80 then remove onto W.Y. FNR: With Col. 1, cast on same as above. Knit 6 rows. Transfer Rib sts. to MB. Knit 1 row. With WRONG SIDE FACING, hang the first section onto these Ndl. Bind off LOOSELY.

ROSETTE SECTION

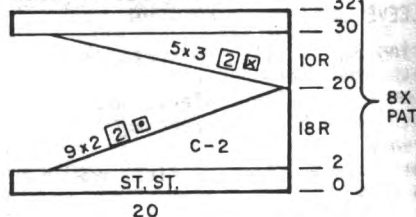

ROSETTE SECTION

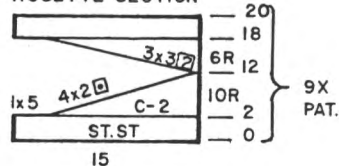

ROSETTES: For Shoulder Trim

T 10+ - With Col. 2, 'e' cast on 20 sts. for LARGE PIECE. Knit 2 rows. ON OPPOSITE SIDE OF CARR. bring to HP 2 sts. 9x (SEE CHART). After row 20, push back to WP 3 sts. 5x. After R 30, knit 2 rows. Repeat for a total of 8 times. Join edges to form a circle. SMALL SECTION: 'e' cast on with Col. 2, 15 sts. and follow chart to form second circle. Join edges to form circle.

FINISHING:

See General Instruction. Single crochet around Rosette shapes and pinch to form flower (See Photo). Insert Elastic through casing at top of bodice if desired.

The leading knitting publication from England, it contains 36 complete and outstanding patterns for women, men and children. Illustrated in full color.

VOLUME 8 is filled with colorful Beach and Resort wear for men, women and children.

VOLUME 9 has an assortment of Sweaters designed to please you and amaze your friends.

Garments are knitted with **PUNCH CARD, ELECTRONIC** and **BULKY** machines. At **\$6.95** postpaid anywhere in the world, it's definitely a **'BEST BUY'**.

MACHINE KNITTING FASHION



Order direct from **KNITKING**
1128 Crenshaw Blvd., Los Angeles, CA 90019

591

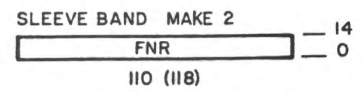
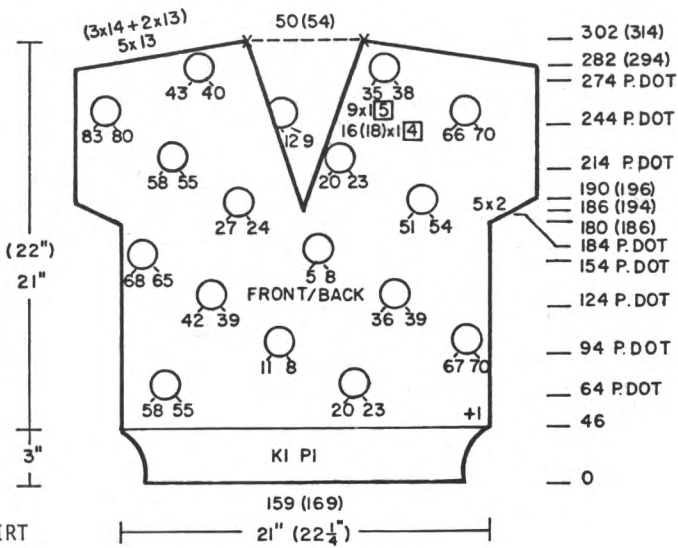

SLEEVE BANDS: Make 2 T 5/5 II
FNR: With Col. 1 cast on 110 (118) sts. Knit 14 rows. Transfer rib sts. to MB. Knit 1 row then remove on W.Y.

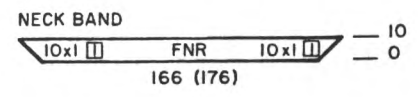

NECKBAND:
FNR: With Col. 1, cast on 166 (176) sts. ON EACH SIDE, inc. 1 st. EVERY ROW 10x. After R 10, transfer rib sts. to MB. Knit 1 row then remove on W.Y.

FINISHING:
See General Instructions. Weave Neckband to neck opening. Weave sleeve bands to sleeve edge.

SKIRT: - Made with Short Row Shaping. W.Y. cast on 190 (195) sts. After several rows end with 1 row Ravel Cord to the right. Change to Col. 1. Counter 0. Knit 4 rows St. st. *Bring all the Ndl. into Holding position. ON THE RIGHT HAND SIDE, push back to 'D' (working) position 40 Ndl. Knit 2 rows. Push 25 Ndl. back to WP. Knit 2 rows. Push 5 Ndl. back to WP. Knit 2 rows. Begin short row decreases. ON RIGHT SIDE, bring into HP 20 Ndl. Knit 2 rows. Release holding Cam and knit 8 rows over all sts. Continue to follow Chart and complete 1 section. REPEAT PATTERN 13 (14)x MORE ending with 4 rows instead of 8 for joining side seam. Remove on contrast W.Y.

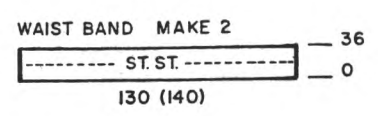

WAISTBANDS - Make 2
St. st.: With col. 1, cast on 130 (140) sts. Knit 36 rows. Pick up first row to form hem. With wrong side facing, hang 1/2 of skirt waist onto these Ndl. Knit 1 row across and BO loosely. Repeat band for second half.

FINISHING:
See General Instructions. Weave side seam. OPTIONAL: Work 2 rows single crochet around lower edge of skirt.

WOMENS POLKA DOT TOP & SKIRT

SIZES: 12/14 (16)
YARN: Venetia
AMOUNT:
Col. 1 24 oz. 28 oz.
Col. 2 2 oz. 2 oz.
TENSION: St. st. 5
K1, P1 Rib 1/1 II
GAUGE: 15 sts. 24 rows = 2"

Make on any Standard Machine with Ribber and Intarsia Carriage. Intarsia method is used for the Polka Dots. Bands are ribbed.

TOP BACK:
K1, P1 Rib: CO 159 (169) sts. Knit 46 rows. Transfer Rib sts. to MB. Add 1 st. on right. Continue in St. st. and INTARSIA DESIGN. Follow the Chart for placement of Polka Dots. After R 180 (186), ON EACH SIDE inc. 2 sts. EOR 5x. Continue in Intarsia Design. After R 282 (294) SHAPE SHOULDERS: ON EACH SIDE, bind off 13 sts. 5x (14 sts. 3x, 13 sts. 2x. BO or remove the sts. on W.Y.

TOP FRONT:
Work the front the same as back to R 186 (194). Divide in center for V neck shaping. Place sts. on left to holding position and complete the right side first. *ON NECK EDGE, dec. 1 st. every 4th row 16 (18)x, 1 st. every 5th row 9x and DON'T FORGET TO COMPLETE THE INCREASES ON SLEEVE EDGE SAME AS BACK. After R 282 (294) SHAPE SHOULDER same as back Bring the sts. on left back to WP, turn Row Counter back to 186 (194) and complete the left half. Follow instructions from *.

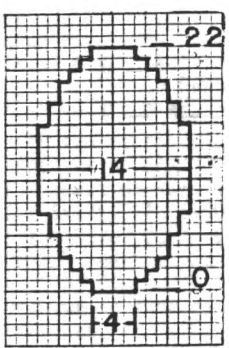
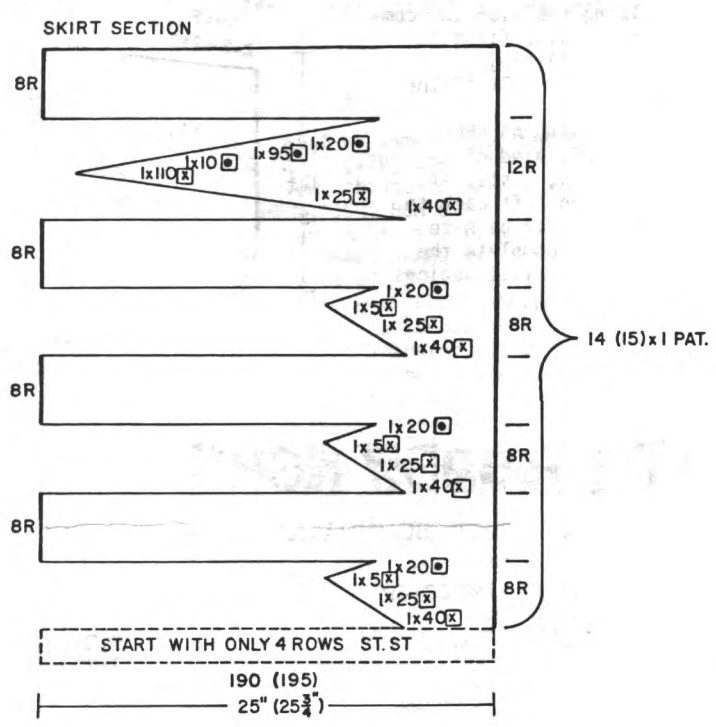



WOMENS ANGORA PULLOVER

SIZES: Small (Medium) [Large]
YARN: Angora = Col. 1, Glace = Col. 2,
 Mirage = Col. 3.

AMOUNT:
 Col. 1 11 12 13 balls
 Col. 2 1 Cone for all sizes.
 Col. 3 1 Spool for all sizes.
TENSION: St. st. Angora on Bulky ma-
 chine with Tension 2.
 For Bands, see Instructions.
GAUGE: Angora St. st. 9.5 sts.
 14 rows = 2"

Body of Pullover was made on the Bulky machine. Bands were knitted on Standard Machine with Ribber. Purchase 3 Appliques and 7 dozen beads to stitch on when garment is completed. See Picture.

FRONT: - Bulky Machine.

W.Y. cast on 84 (90) [96] sts. After several rows, end with 1 row Ravel Cord to the right. Change to Angora. Counter 0. ON EACH SIDE, inc. 1 st. every 4th row 4x AND AT THE SAME TIME, after R 12, mark each side for armhole. Continue in St. st. After R 68 (70) [72], bind off the center 4 sts. Place sts. on left to holding position and complete the right side first. *ON NECK EDGE, bind off 3 sts. 1x, 2 sts. 2x, 1 st. 3 (4) [5]x BUT AT THE SAME TIME, after R 78 (82) [86] SHAPE SHOULDER. Bind off or use Short Row method, 8 sts. 2x, 9 sts. 2x. (9 sts. 4x) [9 sts. 2x, 10 sts. 2x]. Bring the sts. on left back to WP, turn counter back to 68 (70) [72] and complete the left half. Follow instructions from *.

WAISTBANDS: Standard Machine. Make 2.

K1, P1 Rib: Cast on 153 (161) [169] sts with Col. 2 & 3 together. Tension 1/1 I. Knit 146 (150) [154] rows. Transfer Rib sts. to MB. Knit 1 row then remove on contrast W.Y. Bring to WP 84 (90) [96] Ndl's. Hang the open sts. of waistband onto these Ndl's, decreasing evenly across. With WRONG SIDE (Purl side) facing, hang the open sts. of Angora Top onto these Ndl's. Using Angora, knit 1 row BY HAND pushing needles back to A position. (This is necessary in order to have large stitches so waist will have some stretch to it). CAREFULLY bring sts. forward and bind off.

SLEEVE TRIM: Standard Machine

With 1 strd. Glace and 1 strd. Mirage TOGETHER, cast on 122 (128) [134] sts. With tension 4.2, work St. st. to Row 18. Pick up the first row to form hem. Close shoulder and with WRONG side facing, hang marked sleeve edge of Angora Top onto these Ndl's. Bind off loosely. REPEAT FOR OTHER SLEEVE.

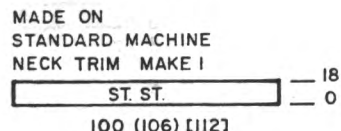
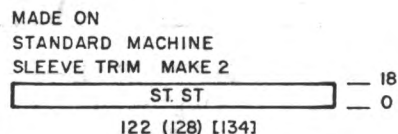
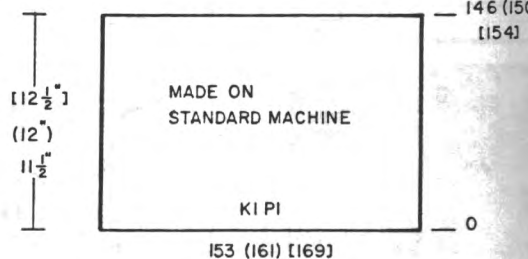

NECK TRIM: Standard Machine. With 1 strd. Glace and 1 strd. Mirage together, cast on 100 (106) [112] st. With Tension 4.2, knit St. st. to R 18. Pick up first row to form hem. Knit 1 row, then remove on W.Y.

FINISHING:

See General Instructions. Weave Neck Trim to neck opening. Sew Appliques to front. Sew Beads around neck and armhole. We spaced the beads 4 sts. apart. Work 1 row single crochet around back slit. Use Mirage as thread for sewing on appliques and beads. Crochet a loop and use 1 bead for back closure.

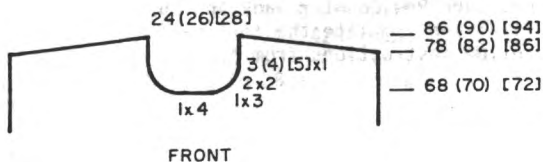

BACK - Bulky Machine.

Work the back same as front to R 64 (68) [72]. Divide in center for back slit. Place sts. on left in holding position and complete the right side first. *Knit to R 78 (82) [86]. SHAPE SHOULDER AND NECK AT THE SAME TIME. SHAPE SHOULDER SAME AS FRONT AND ON NECK SIDE, bind off 7 (8) [9] sts. 1x, 5 sts. 1x. Bring the sts. on left back to WP, turn Row Counter back to 64 (68) [72] and complete the left half. Follow instructions from *.

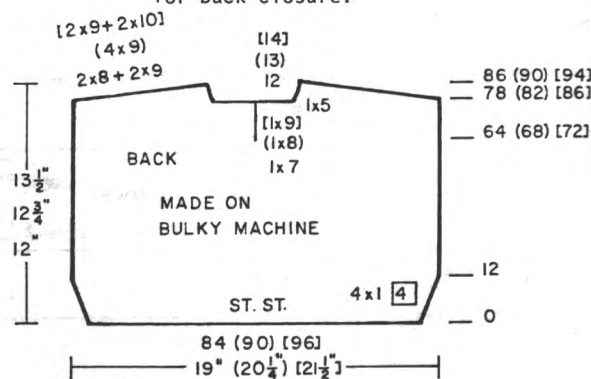

IT'S READY NOW!

KNITKING MAGAZINE BOUND VOLUME 20

- * HARD BOARD COVER
- * COMPLETE INSTRUCTIONS
- * WILL HOLD ANOTHER COMPLETE VOLUME

Price: \$24.95
 Shipping Costs - \$3.25

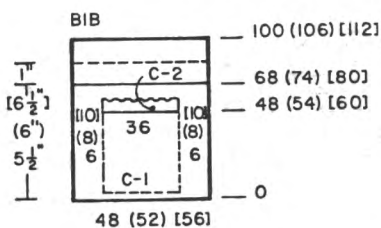

BIB

Bring 48 (52) [56] Ndl. to WP. With wrong side facing, pick up center loop at W.Y. marker on Skirt front then working on each side, pick up loops and hang on empty Ndl. 48 (52) [56] sts. Knit to Row 48 (54) [60]. Break yarn.

Over the center 36 sts. make the Pocket same as you did on Skirt. When completed and all needles are back in WP, turn Counter back to 48 (54) [60]. Knit to Row 68 (74) [80]. Change to Col. 2. Knit to R 100 (106) [112]. Pick up first row of Col. 2 to form hem. Bind off LOOSELY.

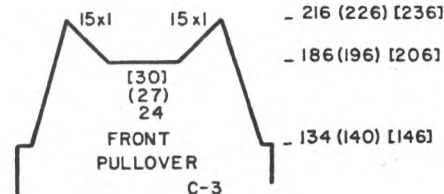

PULLOVER FRONT:

Work the front the same as back to R 186 (196) [206]. Bind off the center 24 (27) [30] sts. place Ndl. on left to HP and complete the right side first. *Continue Raglan shaping and on NECK EDGE, dec. 1 st. EOR 15x. Bring Ndl. on left back to WP Row Counter back to 186 (196) [206] and complete the left half. Follow instructions from *.

SHOULDER STRAP MAKE 2

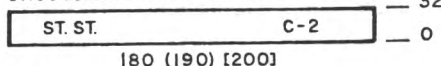

SHOULDER STRAPS: Make 2

'e' cast on with Col. 2, 180 (190) [200] sts. Knit 32 rows St. st. Pick up first row to form hem. Bind off. Fold in half lengthwise and close seam then fold so that seam is in CENTER and steam lightly.

JOIN STRAPS TO SIDE OF BIB. (See Photo). Sew Buttons on other end of Straps at desired length. Crochet loops and attach to inside lower edge of waistband to form buttonholes.

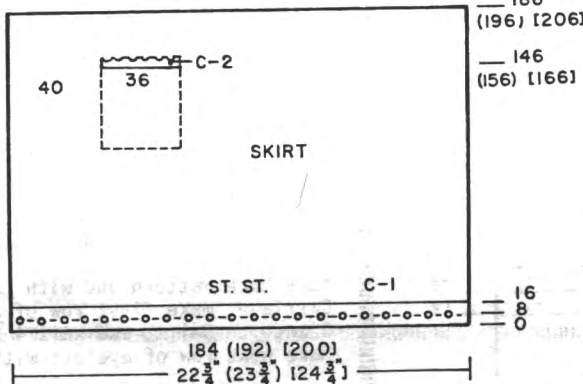
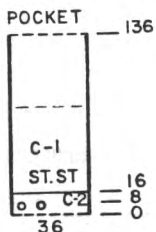

PULLOVER BACK:

W.Y. cast on same as for Skirt. 102 (111) [120] sts. After Ravel Cord row, change to Col. 3. Counter 0. MAKE PICOT HEM SAME AS ON SKIRT. Continue in St. st. to R 134 (140) [146]. SHAPE ARMHOLE: ON EACH SIDE, bind off 3 sts. then ON EACH SIDE, work FULL FASHION DECREASES, 3 stitches over 3 sts. With 3 Ndl. Transfer tool, remove 3 end sts. and place them onto Ndl. 4, 5, 6. Push empty Ndl. out of work. REPEAT these decreases every 10th row 7 (8) [9]x IN ALL. After R 208 (218) [228], bind off the center 48 (51) [54] sts. Place sts. on left to HP and complete right side first. *ON NECK EDGE, dec. 1 st. EOR 3x. Bring the Ndl. on left to WP, turn Counter back to 208 (218) [228] and complete the left half. Follow instructions from *.

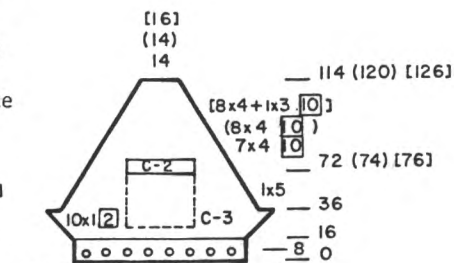

SLEEVES: 60 (68) [76]

'e' cast on with Col. 3. 60 (68) [76] sts. Work the Picot hem same as before and after R 16, hang hem. ON EACH SIDE, inc. 1 st. EOR 10x. After R 36 on EACH SIDE, BO 5 sts. then ON EACH SIDE, FULL FASHION DECREASE 4 sts. over 4 sts. every 10 rows 7 (8)x [4 sts. 8x, 3 sts. 1x] BUT AT THE SAME TIME, after R 72 (74) [76], make POCKET same as before over the center 28 sts. knitting 100 rows for length of pocket. Make Picot Band with color 2. Bring all Ndl. to WP, Counter 72 (74) [76] and continue in Col. 3 to R 114 (120) [126]. Bind off. MAKE SECOND SLEEVE WITHOUT POCKET.

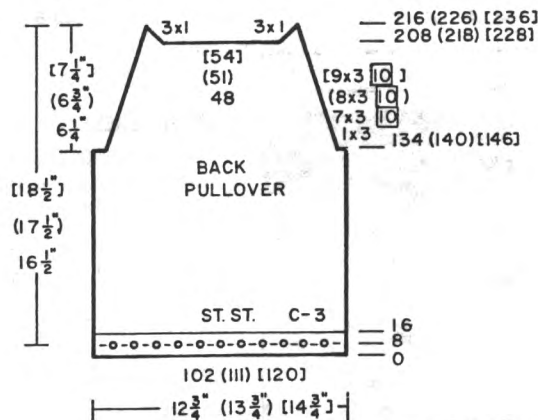

CONTINUED

JUMPER, BLOUSE & SOCKS.

SIZES: 2/3 (4/5) [6/7]

YARN: Regular Venetia

AMOUNT:

Col. 1 12 oz. 13 oz. 14 oz.

Col. 3 8 oz. 9 oz. 10 oz.

Col. 2 2 oz. all sizes

TENSION: 4

GAUGE: 16 sts. 24 1/2 rows = 2"

Make on any Standard or Electronic Machine with Ribber. Stockinette stitch with ribbed bands.

JUMPER SKIRT: Make 2.

W.Y. cast on 184 (192) [200] sts. After several rows end with 1 row Ravel Cord to the right. Counter 0. Col. 1, T 4. Knit 7 rows. Change to T 10. Knit 1 row then make Picot; (Transfer every second st. to neighboring Ndl. leave empty Ndl. in WP).

Knit 1 row. Change to T 4. Continue in St. st. After R 16, pick up first row to form hem. After R 146 (156) [166], make Pocket. At the extreme LEFT, put 40 sts. into HP. Leave next 36 sts. in WP and the remaining to the right in HP. Break yarn. Counter 0. With Col. 2, knit 7 rows. With T 10, knit 1 row then make Picot same as before, knit 1 row. Change to T 4, knit to R 16. Pick up first row of pocket to form hem. Change to Col. 1 and continue in St. st. to R 136.

BRING ALL NDLS. TO WP. Counter 146 (156) [166]. Knit to R 186 (196) [206]. Mark center front with W.Y. then remove on W.Y.. Make second section the same but omit Pocket.

WAISTBAND: Make 1.

Join two sections of skirt together on one side only. W.Y. cast on same as you did for Skirt. 140 (150) [160] sts. After Ravel Cord row, change to Col. 1 and knit 32 rows. Pick up first row to form hem. With wrong side facing, hang the open sts. of skirt onto these Ndl. decreasing evenly across. Bind off loosely.

WAIST BAND MAKE 1

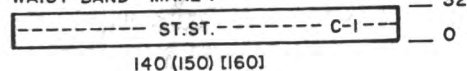

NECKBAND:

K1, P1 Rib: With Col. 3, cast on 149 (155) [161] sts. After regular selvedge, change to T 2/2 II. Knit 32 rows. Transfer rib sts. to MB. Pick up first row to form hem. With WRONG SIDE FACING, locate center of front neck and hang on center needle. Working to the right, pick up sts. along frong neck then sleeve and 1/2 the back. Working to the left pick up sts. in same manner. Bind off.

FINISHING:

Weave raglan sleeves to front and back. Join side seams. Close ribbing center back neck.

STOCKINGS:

K1, P1 Rib: With Col. 1, cast on 41 (47) [53] sts. T O/O II. Knit 22 rows. Transfer rib sts. to MB and continue St. st. After R 64 (68) [72], ON EACH SIDE, remove 11 (12) [13] sts. onto W.Y. Continue St. st. to R 94 (108) [122]. CHANGE TO Col. 2 and WORK SHORT ROWS: ON OPPOSITE SIDE OF CARR. bring 1 st. to HP 9x (be sure to wrap inside Ndl. to prevent holes). ON OPPOSITE SIDE OF CARR. bring back to WP 1 st. EOR 9x. Change to Col. 1 and continue St. st to R 160 (184) [208]. CHANGE TO COL. 3 and WORK SHORT ROWS for Heel. ON OPPOSITE SIDE OF CARR, bring to HP, 1 Nd1. 9x ON EACH SIDE, then push back 1 Nd1. 9x ON EACH SIDE. After R 196 (220) [244], remove the sts. onto W.Y.

POCKET FOR STOCKING:

With 2 strds. Col 1, 'e' cast on 12 sts. Knit 12 rows. Change to Col. 2 knit 4 rows. After R 16. bind off.

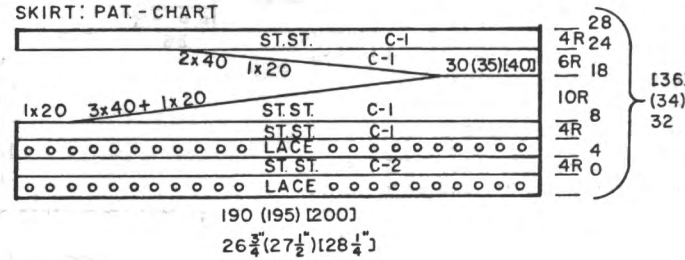
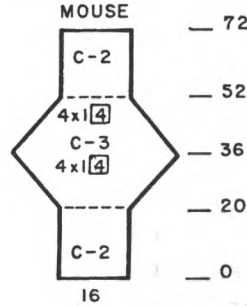
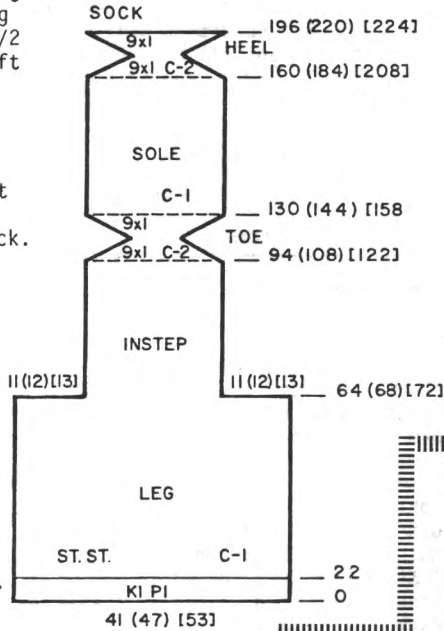
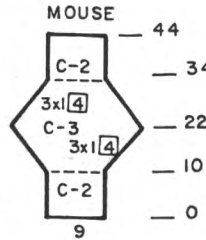
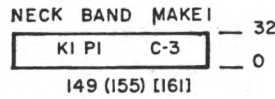

SKIRT:

W.Y. cast on 190 (195) [200] sts. After several rows end with 1 row Ravel Cord to the right. Change to Col. 1. Counter 0. Knit 2 rows. *Set Lace Pattern and with Lace Carriage, make first row of eyelets. Change to Col. 2 and knit 4 rows. Make next row of eyelets with Carr.

Change to Col. 1 and knit 4 rows Start SHORT ROWS. ON THE LEFT S bring to HP 20 sts. 1x, then 40 sts. 3x. 20 sts. 1x. Push back to WP 20 sts. 1x, then 40 sts. 2x. ALL NDLS. IN WORK, With Col 1, knit 4 rows St. st. REPEAT FROM * 32 (34) [36]x in a Remove on W.Y.

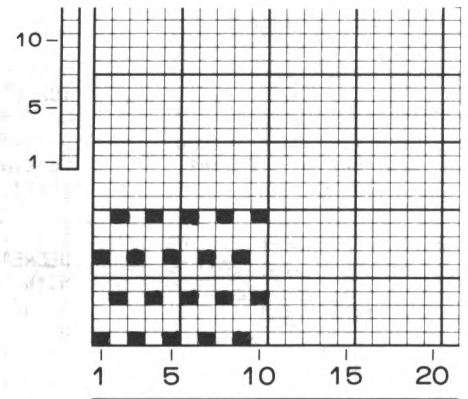
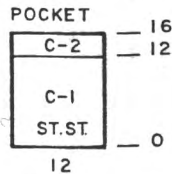

594



WOMENS DRESS

SIZES: 6/8 (10/12) [14/16]
 YARN: Venetia = Col. 1
 Glace = Col. 2
 AMOUNT: Col. 1 25 oz. 26 oz. 27 oz.
 Col. 2 1 Cone all sizes.
 TENSION 6
 GAUGE: 14 sts. 20 1/2 rows = 2"

Make on any ELECTRONIC or STD. Machine with Lacemaker. Skirt section knitted sideways with Short Rows and Lace.

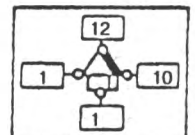

TOP FRONT:
 Bring to WP 118 (124) [130] Ndl's.
 Hang 1/2 of Skirt waist edge onto these Nds. Counter 0.
 *With Col. 1, knit 4 rows.
 Set Lace Pattern and make row of eyelets with Lace Carr.
 Change to Col. 2, knit 4 rows.
 Make eyelets and REPEAT FROM * to Row 40 (44) [48]. CONT. IN PAT. SHAPE ARMHOLE: ON EACH SIDE, bind off 4 (5) [6] sts. 1x, then 4 sts. 1x, 2 sts. 1x, 1 st. 4x. BUT AT THE SAME TIME, after R 46 (50) [54] divide in the center for 'V' neck shaping. Place the sts. on the left in NWP (knit them back by hand with a Ravel Cord to A position) BE SURE TO NOTE PATTERN ROW.
 *ON NECK EDGE, dec. 1 st. every 4th row 15 (17)x (1 st. every 4th row 14x, 1 st. every 3rd row 5x).
 After R 112 (120) [128], remove the remaining sts. on W.Y. Bring sts. on left back to WP, turn Row Counter back to R 46 (50) [54] WATCH PATTERN and complete the left half. Follow instructions from *.

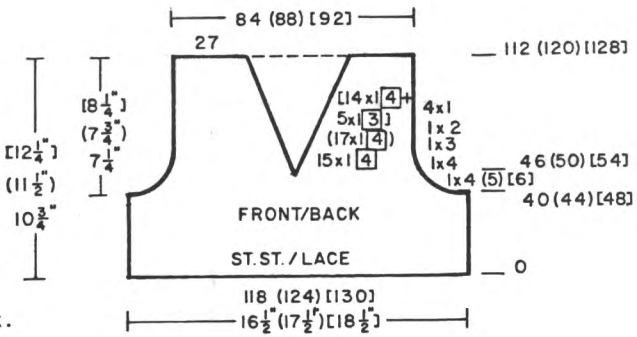

SLEEVES:
 W.Y. cast on 97 (100) [103] sts. After several rows end with 1 row Ravel Cord to the right. Counter 0. Change to Col. 1. Knit 2 rows. *Make eyelets, change to Col 2, knit 4 rows. Make eyelets Change to Col. 1 and knit 14 rows.* REPEAT FROM * TO *. AT THE SAME TIME after R 8 (10) [12] inc. 2 sts. EOR 21 (23) [25]x. After R 50 (56) [62] continue in Pattern.
 After R 184 (196) [208] dec. 2 sts. EOR 21 (23)[25]x. After R 234 (252) [270] remove remaining sts. on W.Y.

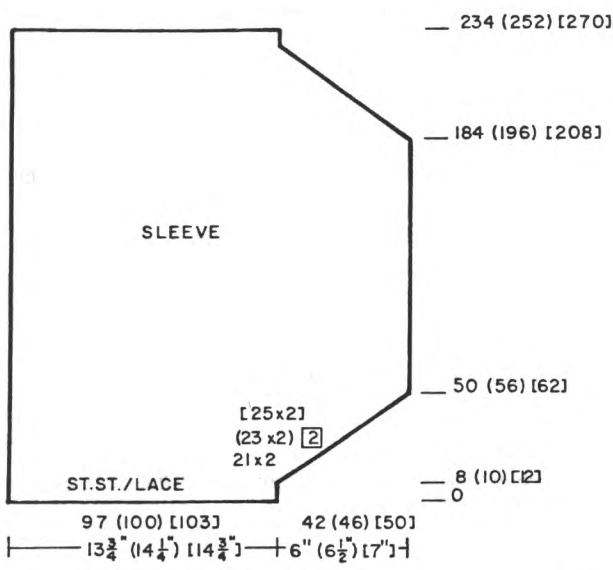

SLEEVE BANDS:
 With Col. 1, 'e' cast on over every other Ndl. 44 (50) [56] sts. then bring empty ndls. to WP. Knit 10 rows.
 Make 1 row eyelets, knit 4 rows. Make eyelets. Change to Col. 2. Knit 4 rows REPEAT FROM * TO * BUT AT THE SAME TIME after R 20 Pick up first row to form hem. Knit in Pattern to R 40. Remove on W.Y.

BODICE CHART

o o LACE o o o	4R
C-2	4R
o o LACE o o o	4R
C-1	4R

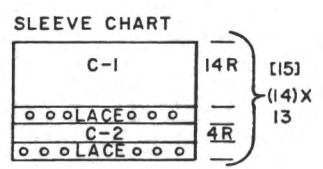
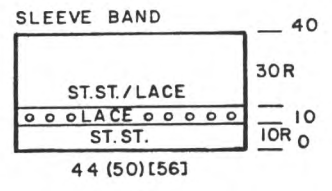

FINISHING:
 See General Instructions. Work 2 rows single crochet around Neck edge and and bottom of dress using 2 strands Col. 2. SHOULDER PADS - Optional. 'e' cast 24 sts. with Col. 1. Knit 40 rows. Bind off. Stuff to desired thickness (fold in half first) then sew around edges.

595



WOMENS PULLOVER
 SIZES: 8/10 12/14
 YARN: Nordic
 AMOUNT:
 Col. 1 12 oz. 13 oz.
 Col. 2 12 oz. 13 oz.
 TENSION: Bulky Machine Tension 3 for Fair Isle Pattern Ribbing - See Instructions.
 GAUGE: 11.5 sts. 11.5 rows = 2"

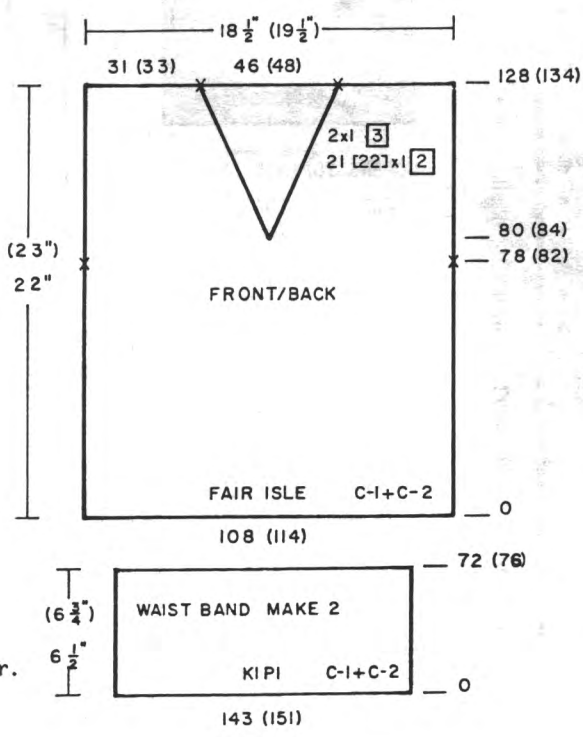

BACK: KH 260 Bulky Machine.
 W.Y. cast on 108 (114) sts. After several rows end with 1 row Ravel Cord to the right. Counter 0. Change to Col. 1. Knit 2 rows, setting Fair Isle Pat. on 2nd row.
 Knit in Pattern to R 78 (82). Mark each side with W.Y. for armhole. After R 128 (134), mark Neck opening with W.Y. then BO or remove each section on contrast W.Y.

FRONT: KH 260 Bulky Machine.
 Work the front same as back to R 80 (84). Divide in center for 'V' neck shaping. Place sts. on the left to HP and complete the right side first. MARK PAT. ROW.
 *ON NECK EDGE, dec. 1 st. EOR 21 (22)x. then 1 st. every 3rd row 2x. After R 128 (134) BO or remove on W.Y. the remaining sts. Bring Ndl's. on left to WP. Turn Counter back to 80 (84) SET CORRECT PAT. ROW and complete the right side. Follow instructions from *.

Body of Pullover is a Fair Isle Design knitted on the KH 260 Punch Card machine. All Ribbing is made on Standard machine with Ribbing Attachment. Can use Color Changer.

SLEEVES: KH 260 Bulky Machine.

W.Y. cast on 100 (106) sts. same as front and back. After setting Pattern, with Col. 1 and Col. 2, Knit 86 (90) rows. Bind off or remove on W.Y.

WAISTBANDS: Make 2. Standard machine with Ribber and Color Changer if you have one.

K1, P1 Rib: With Col. 1, cast on 143 (151) sts. After regular selvedge, change to T 4/4 I and begin Color stripes.

Knit 2 rows Col. 2
2 rows Col. 1

Repeat these 4 rows to R 70 (74)

With T 5/5 I, knit 1 row.

With T 6/6 I, knit 1 row.

After R 72 (76), transfer Rib st. to MB. With wrong side facing, hang open sts. of FRONT onto these Ndl. (Pick up cross thread between sts. to fill in extra sts. needed between Bulky and Regular sts. Bind off LOOSELY.

REPEAT FOR BACK WAISTBAND.

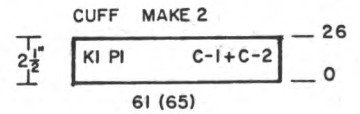
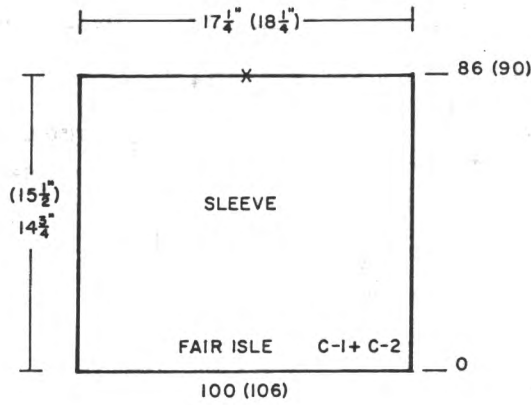

SLEEVE CUFF: Make on Standard Machine with Ribbing Attachment and Color Changer if you have one.

K1, P1 Rib. With Col. 1, cast on 61 (65) sts. same as for Waistband. Knit in stripe Pattern to R 24. With T 5/5 I, knit 1 row. With T 6/6 I, knit 1 row. Transfer Rib sts. to MB and with wrong side facing, hang open sts. of Sleeve edge onto these Ndl. decreasing evenly across. Bind off LOOSELY.

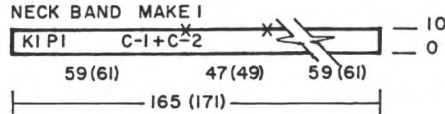

NECKBAND: Make on Standard Machine with Ribbing Attachment same as for other bands.

K1, P1 Rib: With Col. 1, cast on 165 (171) sts. After regular selvedge, change to T 5/5 I and knit in color stripes of 2 rows Col. 2, 2 Rows Col. 1. After R 10, transfer Rib sts. to MB and remove on W.Y.

FINISHING:

See General Instructions. Close shoulders and weave Neckband to neck opening overlapping at front 'V'.

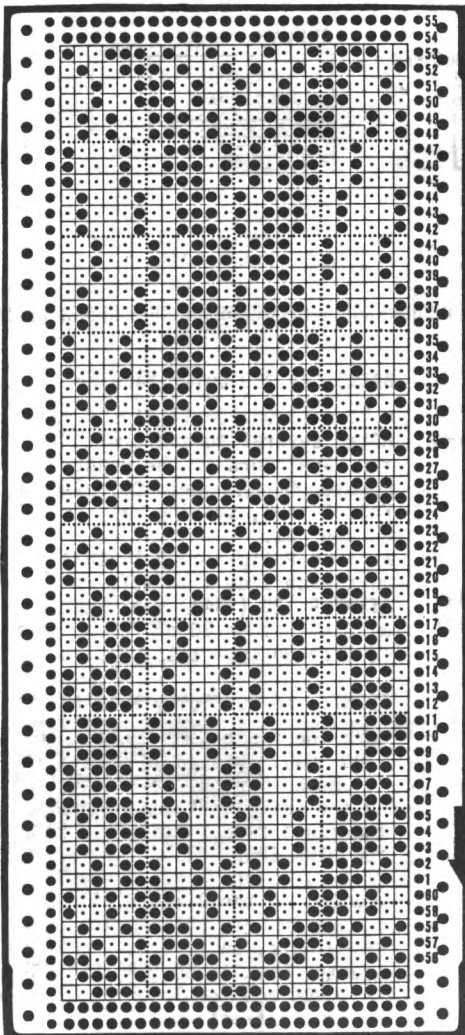
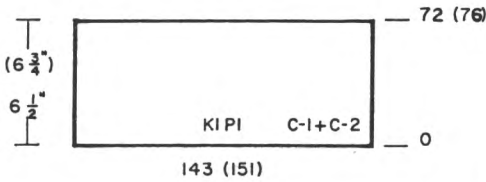

596

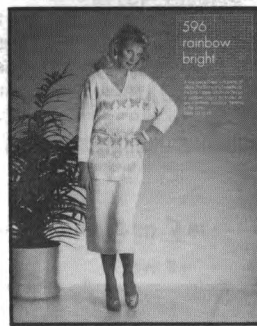

WOMENS TOP & SKIRT

SIZES: 10/12 (14/16)

YARN: Venetia

AMOUNT:

Col. 1 45 oz. 46 oz.

Col. 2 3 oz. 3 oz.

Col. 3 3 oz. 3 oz.

Col. 4 3 oz. 3 oz.

TENSION: St. st. 5, Rib. 3/3 I

GAUGE: Top, 16 sts. 23 rows = 2"

Skirt, 14 sts. 21.5 rows = 2"

Make on any Electronic machine with Ribber. Top has rows of Fair Isle designs. Skirt is FNR.

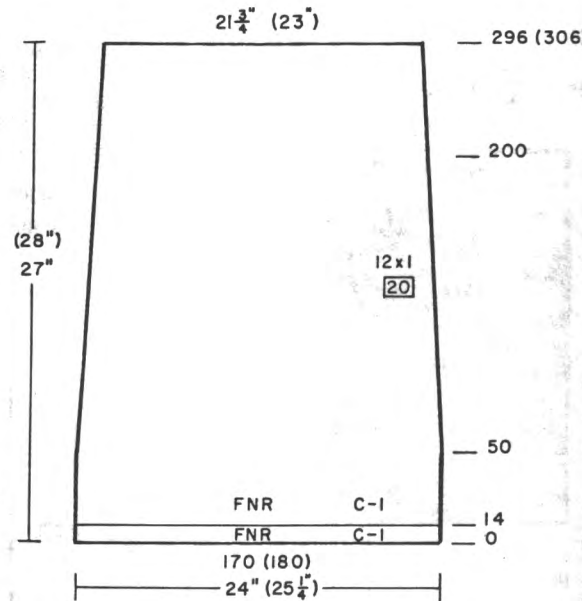

SKIRT: Make 2

FNR: With Col. 1, cast on 170 (180) sts. After regular selvedge, change to T 6/6 II. Knit 14 rows. Change to T 4/3 I, knit 50 rows. ON EACH SIDE, dec. 1 st. every 20th row 12x. After R 200, change to T 3/3 I. After R 296 (306), transfer rib st. to MB. Knit 1 row then remove on W.Y.

WAISTBAND FOR SKIRT: Make 2.

Bring 120 (130) Ndl. to WP.
With wrong side facing, hang open sts. from skirt edge onto these Ndl. decreasing evenly across.
With T 5, knit 36 rows St. st.
Pick up first row of band to form hem. Bind off loosely.

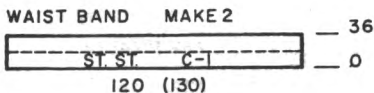

PATTERN CHART

C-1 C-4 P3		30R
C-1 C-3 P2		8 (10)R
C-1 C-2 P1		30R

TOP BACK:

FNR T 6/6 II. With Col. 1, cast on 180 (190) sts. Knit 20 rows. Transfer rib sts. to MB and continue St. st. T 5.
After R 25, set Pat. 1 and follow Chart. (30 Rows Pattern, 8 rows St. st. for SMALL SIZE (30 rows Pattern, 10 rows St. st. for LARGER SIZE).
After R 212 (216), mark with WY for neck opening and bind off or remove on W.Y.

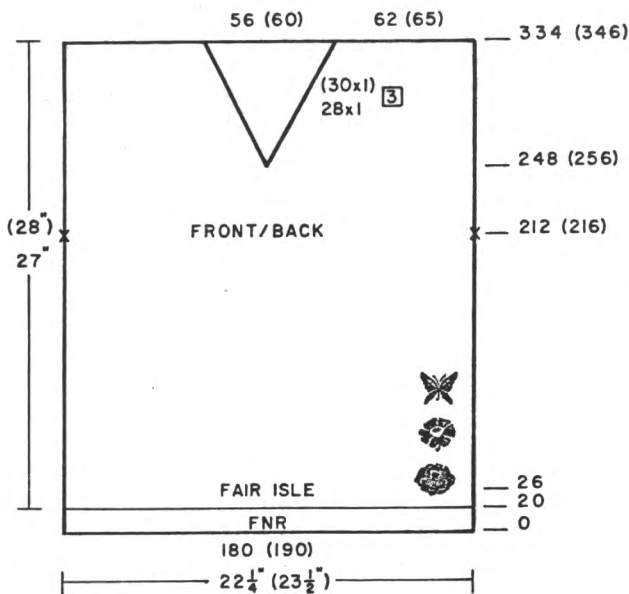

TOP FRONT:

FNR: Cast on same as back and knit to R 212 (216). Mark each side for sleeve opening.
After R 248 (256) divide in center for 'V' neck shaping.
Place sts. on left to holding position and complete right side first.
*ON NECK EDGE, dec. 1 st. every 3rd row 28 (30)x.
After R 334 (346), bind off or remove on W.Y. Bring the Ndl. on left to WP, turn Row Counter back to 248 (256) and complete the left half. Follow instructions from *.

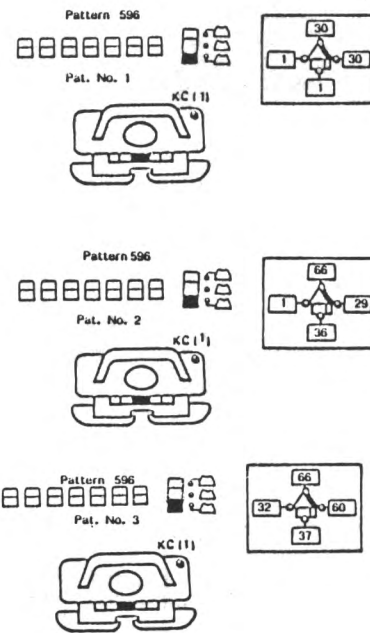

SLEEVES:

With Col. 1, cast on 180 (190) sts. Work St. st. ON EACH SIDE, dec. 1 st. every 6th row 8x, then 1 st. every 4th row 39 (41)x.
After R 174 (180), remove on W.Y.

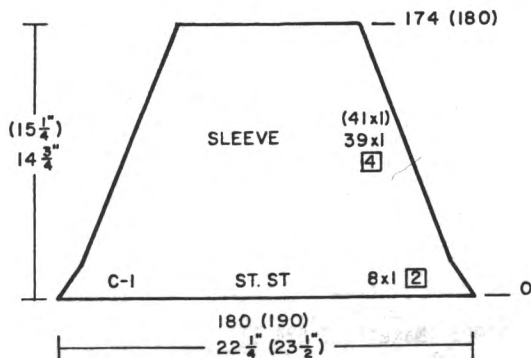

SLEEVE BANDS: Make 2

FNR Rib. T 6/6 II. With Col. 1, cast on 54 (60) sts. After regular selvedge, knit 10 rows. Transfer Rib sts. to MB. Hang open sts. of sleeve onto these Ndl. decreasing evenly across. Bind off loosely.

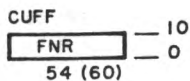

NECKBAND: 1 Piece.

FNR: T 6/6 II. With Col. 1, cast on 162 (170) sts. After regular selvedge, knit 10 rows BUT AT THE SAME TIME, ON EACH SIDE, inc. 1 st. EVERY ROW 10x.
Transfer Rib sts. to MB. Knit 1 row then remove on W.Y.

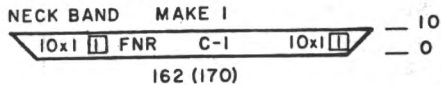

FINISHING:

See General Instructions.
Weave the Neckband to neck edge and join at center of 'V'.

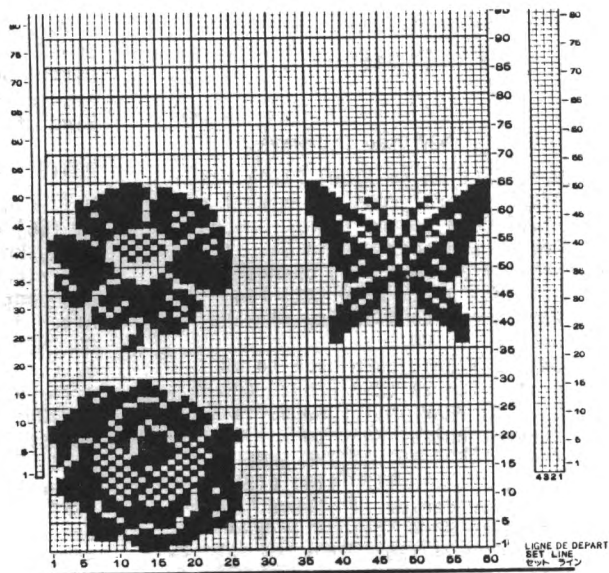



WOMENS LEISURE SUIT

SIZES: 8/10 (12/14) [16]

YARN: Amore

AMOUNT:

Col. 1	11	12	13 Balls
Col. 2	3	3	3 Balls
Col. 3	3	3	3 Balls

TENSION: St. st. 6, Rib. 4/4 II

GAUGE: 14 1/2 sts. 22 1/2 Rows = 2"

Make on any Std. Machine with Ribber. Stockinette stitch with Ribbed Bands.

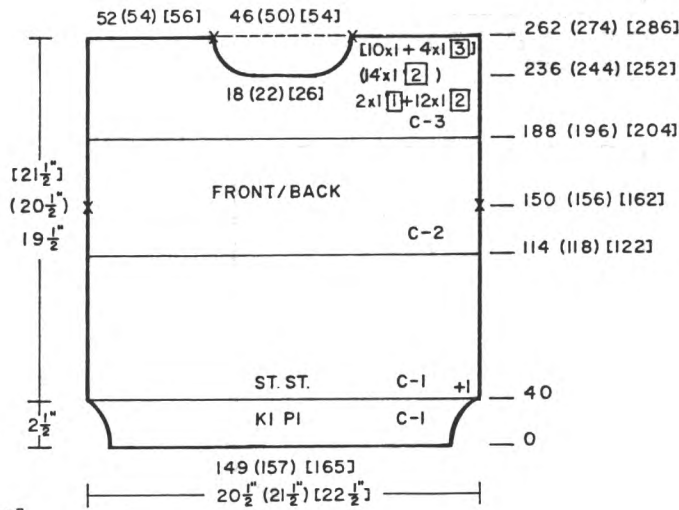

SLEEVE BAND MAKE 2

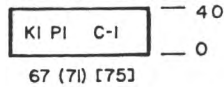

SLEEVE BANDS: Make 2.

K1, P1 Rib: With Col. 1, cast on 67 (71) [75] sts. After regular selvedge, knit 40 rows. Transfer Rib sts. to MB. With wrong side facing, hang sleeve edge onto these Ndls. Bind off loosely.

NECK BAND MAKE 1

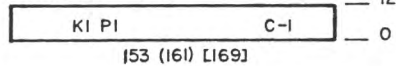

NECK BAND: Make 1, T 5/4 II

K1, P1 Rib: With Col. 1 cast on 153 (161) [169] sts. After selvedge, knit 12 rows. CLOSE 1 SHOULDER. With wrong side facing, hang neck edge onto these Ndls. Bind off loosely.

PANTS FRONT: Make 1, reverse 1.

W.Y. cast on with Col. 1 62 (66) [70] sts. After several rows, knit 1 row Ravel Cord to the right. Change to Col. 1 and continue in St. st. Counter 0. After R 44 SEE CHART FOR INCREASES ON INSIDE EDGE AS SHOWN FOR YOUR SIZE. After R 290 (296) [302] SHAPE CROTCH: Bind off 3 sts. 1x, 2 sts. 2x, 1 st. every 4th row 3 (5) [7]x. After R 357 (369) [381], ON THE LEFT (right for 2nd section), decrease 1 st. every 10th row 7x. After R 428 (440) [452], BO or remove on W.Y. Make 2nd section with reverse shapings.

BACK:

K1, P1 Rib: With Col. 1 cast on 149 (157) [165] sts. T 4/4 II. After regular selvedge, knit 40 rows. Transfer Rib sts. to MB. Add 1 st. on the right side. With Col. 1, continue in St. st. After R 114 (118) [122], change to Col. 2. After R 150 (156) [162], mark each side with W.Y. for setting in sleeves. After R 188 (196) [204], change to Col. 3 and continue in Stripe Pattern. After R 262 (274) [286] mark neck opening with W.Y. and BO or remove on W.Y.

FRONT:

Work front same as back to R 236 (244) [252]. Bind off the center 18 (22) [26] sts. for neck. Place sts. on left into HP and complete the right side first. *ON NECK EDGE, BO 1 st. EOR 12x, 1 st. EVERY ROW 2x (1 st. EOR 14x) [1 st. EOR 10x, 1 st. every 3rd Row 4x]. After R 262 (274) [286] BO remaining sts. Bring Ndls. on left to WP, turn Row Counter back to 236 (244) [252] and complete left half. Follow instructions from *.

SLEEVE MAKE 2

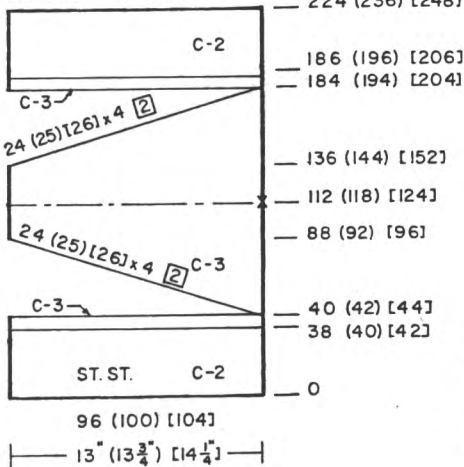

SLEEVES: Knitted Sideways.

W.Y. Cast on 96 (100) [104] sts. After several rows end with 1 row Ravel Cord to the right. Change to Col. 2 and continue in St. st. After R 38 (40) [42] change to Col. 3. After R 40 (42) [44] Work Short Rows: Bring all the needles to HP. ON THE RIGHT, push back to WP 4 sts. EOR 24 (25) [26]x. (BE SURE TO WRAP INSIDE NDLS. to prevent holes. Knit to R 136 (144) [152] BUT AT THE SAME TIME, after R 112 (118) [124], mark for center of sleeve. Bring to HP 4 sts. on left side EOR 24 (25) [26]x. After R 184 (194) [204] knit 2 rows over all sts. Change to Col. 2. After R 224 (230) Remove on W.Y.

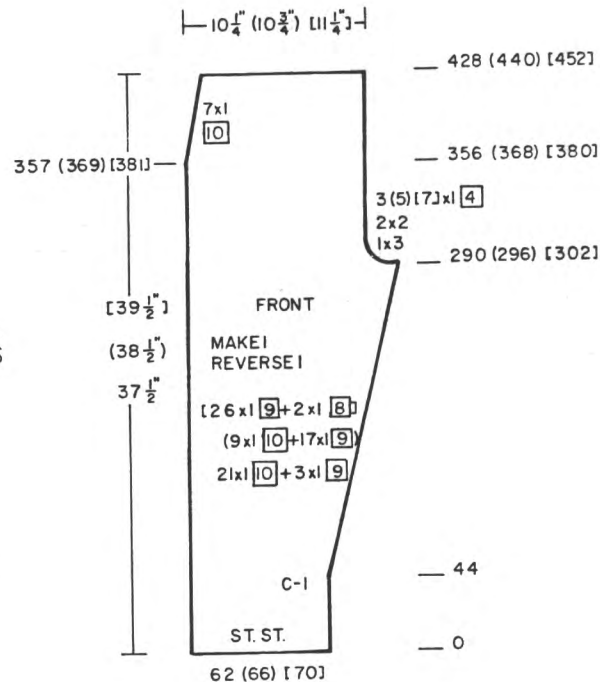

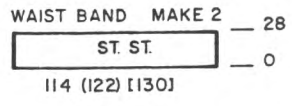
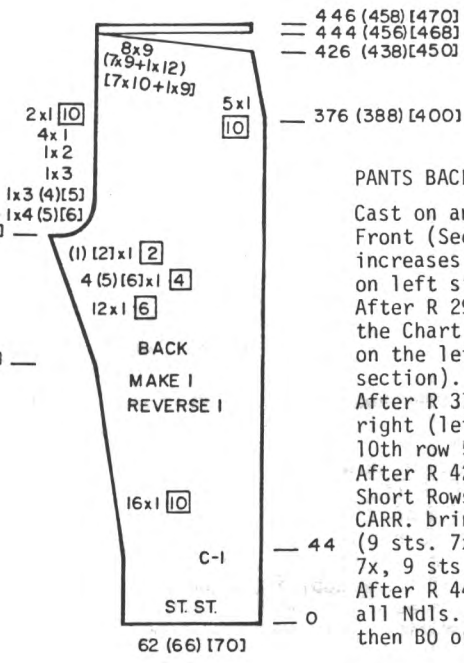

WAISTBAND: Make 2.
 Join the center (crotch) seams of fronts together.
 Bring to WP 114 (122) [130] Ndls. With wrong side facing, hang the front edge of joined sections onto the Ndls. decreasing evenly across. With Col. 1, knit 28 rows. Pick up first row of band to form hem. Bind off loosely.
JOIN INSIDE SEAM OF BACK SECTIONS. Bring the same amount of Ndls. to WP and complete waistband same as for front.

PANTS BACK: Make 1, reverse 1.
 Cast on and knit to R 44 same as Front (See Chart) and follow increases and decreases as noted on left side.
 After R 291 (297) [303] Follow the Chart for the crotch shaping on the left side (right for 2nd section).
 After R 376 (388) [400], on the right (left) dec. 1 st. every 10th row 5x.
 After R 426 (438) [450], work Short Rows: ON OPPOSITE SIDE OF CARR. bring to HP 9 sts. 8x (9 sts. 7x, 12 sts. 1x) [10 sts. 7x, 9 sts. 1x].
 After R 444 (456) [468] bring all Ndls. to WP, knit 2 rows then BO or remove on W.Y.

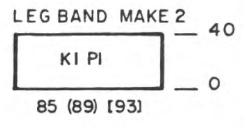

LEG BANDS: Make 2.
 K1, P1 Rib. T 4/4 II
 Cast on 85 (89) [93] sts. with Col. 1. Knit 40 rows. Transfer Rib sts. to MB. With wrong side facing, hang lower edge of leg onto these Ndls. decreasing evenly across. Pick up first row of -and to form hem. Bind off loosely.

FINISHING:
 See General Instructions.

598

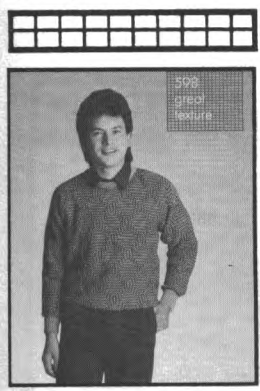

MENS SWEATER:

SIZES: 36/38 (40/42) [44]
YARN: Bulky Venetia
AMOUNT:
 Col. 1 19 oz 20 oz. 21 oz.
 Col. 2 15 oz. 16 oz. 17 oz.
TENSION: Pattern 10+ Rib. 5/4.2 I
GAUGE: 11 sts. 25 rows = 2"

Make on any Standard machine with Ribber. 930 Machine owners use Pat. No. 294 from Pat. Book. A Two Color Tuck Stitch with the Purl side as the right side. Bands are ribbed.

BACK:

Work the back the same as front to R 302 (314) [326]. Bind off the center 32 (36) [40] sts. place the Ndls. on left to HP and complete the right side first. MARK PAT. ROW.
 *ON NECK EDGE, BO 3 sts. 1x, 1 st. 2x, After R 312 (324) [336], BO or remove on W.Y. the remaining sts.
 Bring the Ndls. on left to WP, turn Row Counter back to 302 (314) [326] and complete the left half. Don't forget to SET CORRECT PAT. ROW. Follow the instructions from *.

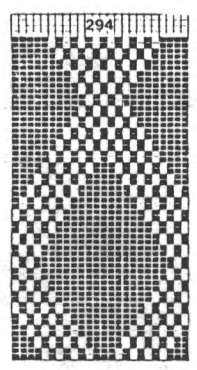

FRONT:

K1, P1 Rib: With Col. 1, cast on 117 (123) [129] sts. After Selvedge, knit 30 rows. Transfer Rib sts. to MB. Add 1 st. on the right side. Carriage on the RIGHT, set Pattern and knit 1 row to the left to select Ndls. Carr. on LEFT, push in BOTH TUCK BUTTONS, knit 1 row to the right. Remove Col. 1 from Feeder and change to Col. 2. Knit 2 rows. Change to Col. 1, knit 2 rows etc.
REPEAT FOR PATTERN THROUGHOUT.
 After R 190 (198) [206], mark each side for sleeve opening.
 After R 276 (284) [292], **SHAPE NECK:** Bind off the center 18 (20) [22] sts. Place sts. on left to HP and complete the right side first. (MARK PAT. ROW)
 *ON NECK EDGE, bind off 3 sts. 1x, 2 sts. 2x, 1 st. every 4th row 6 (7) [8]x.
 After R 312 (324) [336], bind off or remove on W.Y. the remaining sts.

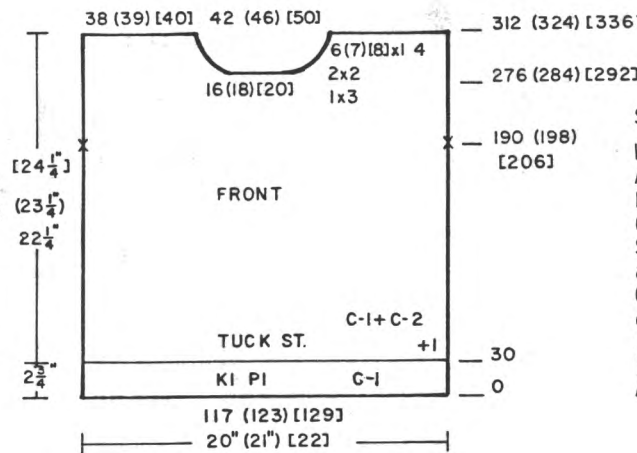
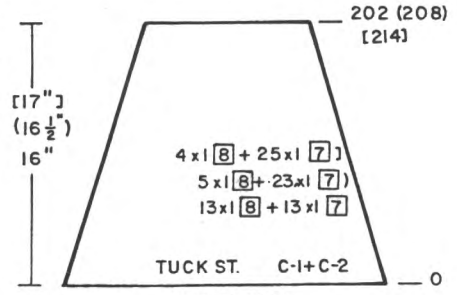
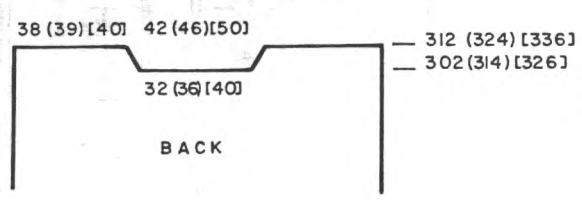

SLEEVES:

W.Y. cast on 110 (116) [122] sts. After several rows end with 1 row Ravel Cord to the right. Change to Col. 1. Counter 0. Set Pattern and continue the same as back BUT AT THE SAME TIME, ON EACH SIDE, decrease 1 st. every 8th row 13x, every 7th row 13x. (every 8th row 5x, every 7th row 13x) [every 8th row 4x, every 7th row 25x]. After R 202 (208) [214], remove on W.Y.

SLEEVE BANDS:

K1, P1 Rib: With Col. 1, cast on 57 (61) [65] sts. After regular selvedge, knit 30 rows. Transfer Rib sts. to MB. With knit side facing, hang open sts. of sleeve edge onto these Ndl's. doubling the end st. if necessary. Bind off LOOSELY. REPEAT FOR SECOND SLEEVE.

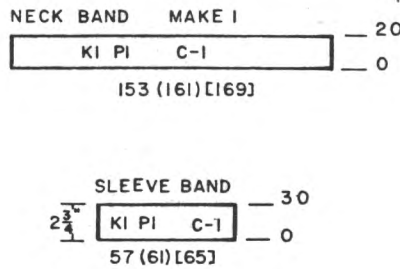

NECKBAND: Make 1.

CLOSE 1 SHOULDER. K1, P1 Rib: With Col. 1, cast on 153 (161) [169] sts. After regular selvedge, knit 20 rows. Transfer Rib sts. to MB. With knit side facing, hang neck edge onto these Ndl's. Bind off LOOSELY.

FINISHING:

See General Instructions. Fold Neck and sleeve bands to the inside and sew in place.

599



LACE TABLE COVER

SIZE: Approx. 68" X 76"
YARN: Glace and Sewing Thread
AMOUNT:
Col. 1 White Glace 45 oz.
Col. 2 Grape 1 small spool
Col. 3 Red 1
Col. 4 Purple 1
Col. 5 Wine 1
Col. 6 Yellow 1
Col. 7 Leo Green 1
Col. 8 Toast 1
Col. 9 Orange Venetia 1 oz.
Col. 10 Dark Green Venetia 1 oz.
White sewing thread 10 Spools
TENSION: Fair Isle, Pat. T 3.1
Lace Pat. T 4.
GAUGE: Lace = 15 sts. 20 rows = 2"

Make on any Standard Punch Card or Electronic machine with Lace Carriage. Fair Isle Designs are Single Motifs.

IMPORTANT NOTE: The single Motif Patterns are made in Panels of 50 sts. and 90 rows with Fair Isle isolated in center. Check your Instruction Manual for wrapping the outside st. on each side when knitting the Motifs. Each Motif begins on a different row as follows:
GRAPES - Begin Pat on Row 14
STRAWBERRIES begin on R 24
BEETS begin on R 24
PINEAPPLE begin on R 16
CHERRY begin on R 24
LEMON begin on R 28
ORANGE begin on R 28
WHEN 90 rows are completed, you must knit 20 rows of LACE before beginning the next section which begins with St. st. then isolated Fair Isle Pattern on specified rows.

PANELS: Make 6.

With 1 strand White Glace and 1 strand thread together 'e' cast on 50 sts. Tension 3.1. Work St. st. to required row number (SEE IMPORTANT NOTE). Work the single Motif with correct color. After R 89, change Tension to 4. Knit 1 row to the right. Set Lace Pat. and knit 20 rows Lace. Follow the Chart for the Motif changes. When you have completed 3 Motifs, turn the Punch Card upside down and complete the second half. End with Stockinette stitch omitting the 20 rows of Lace. Bind off

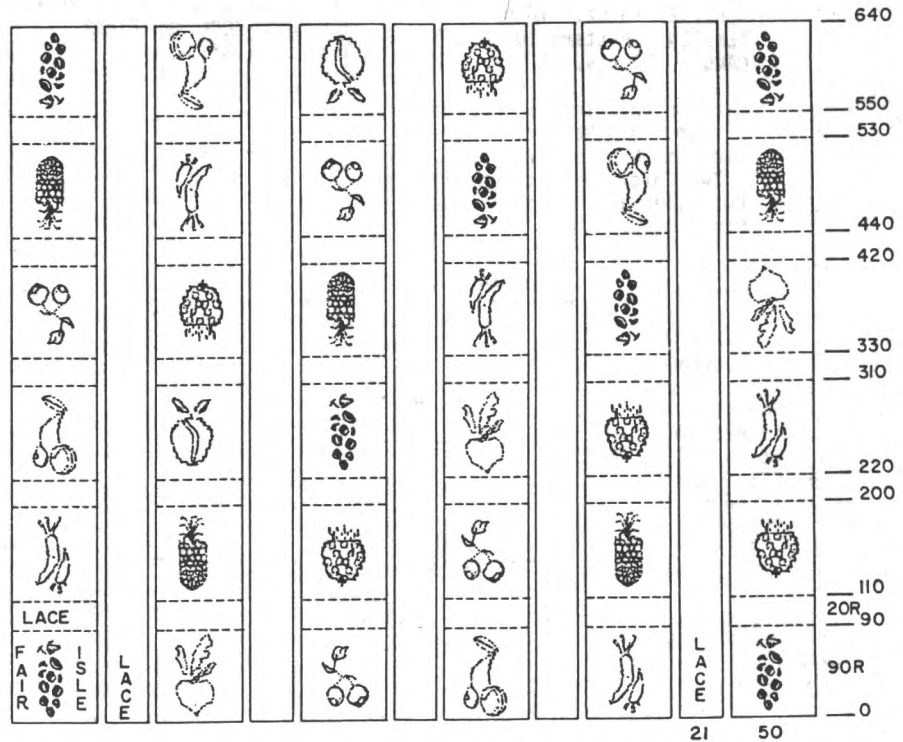

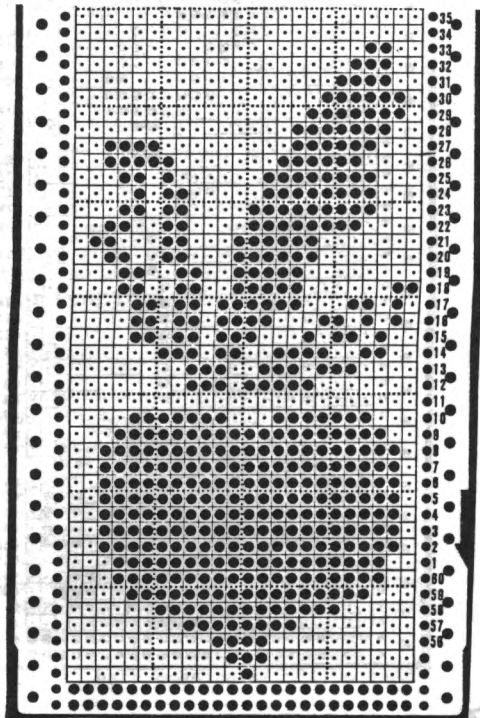
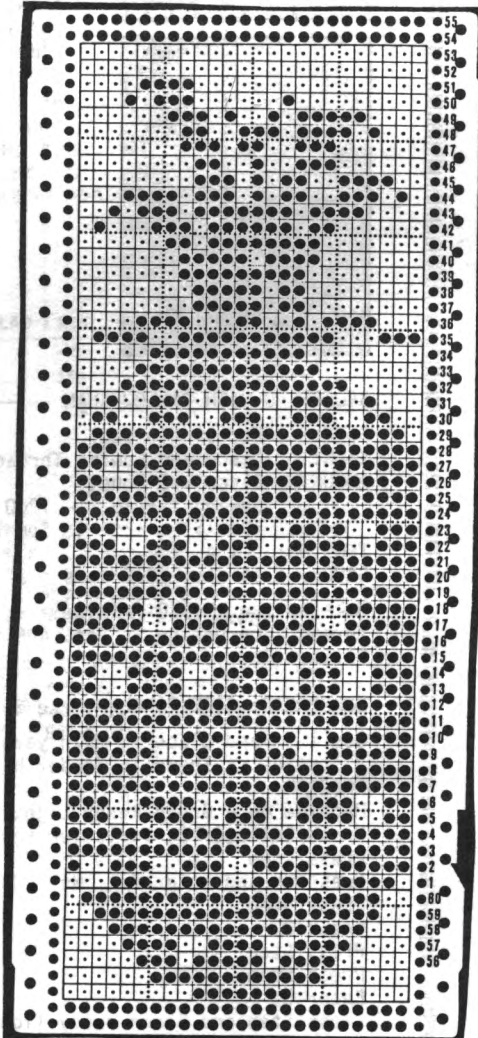
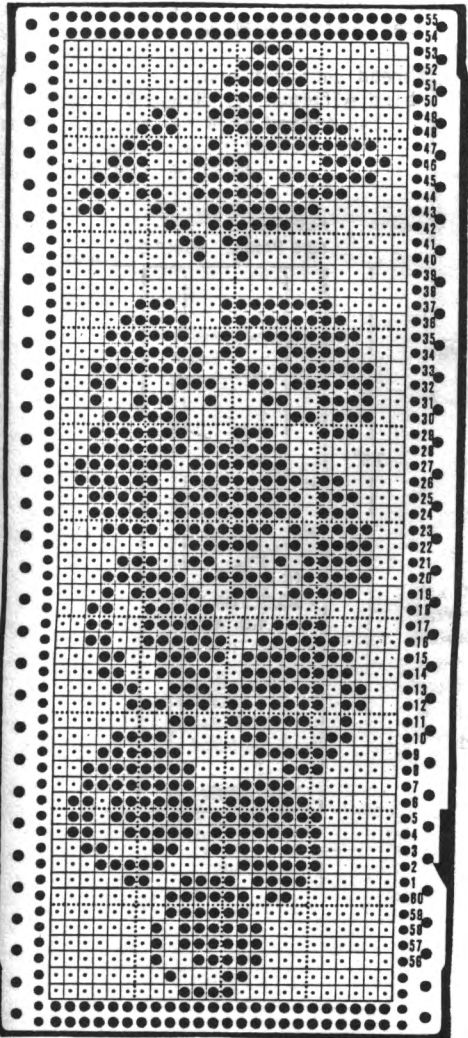
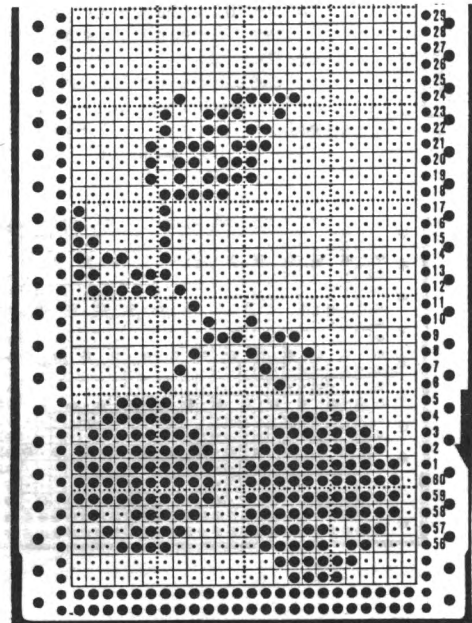
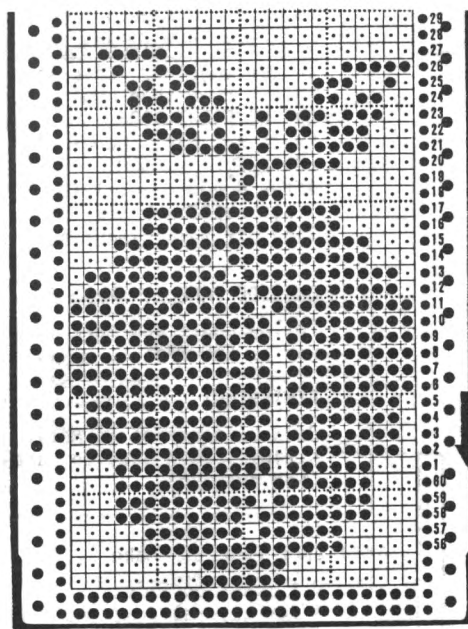
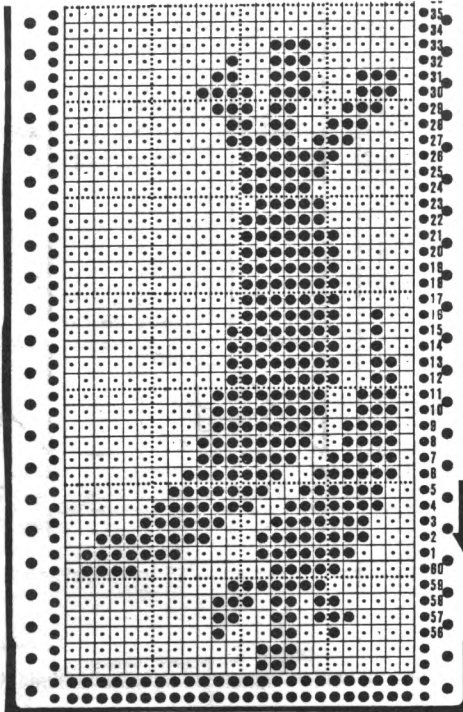
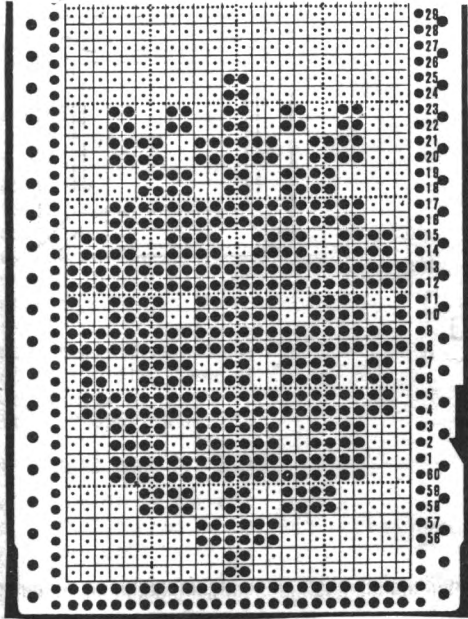

OUTSIDE END PANELS: Make 2.

With 1 strd. Glace and 1 strd. thread together 'e' cast on 2 sts. Knit 2 rows then begin Lace Pat. ON THE RIGHT SIDE, inc. 1 st. EVERY ROW 53x, then 1 st. EOR 22x.
After R 600, dec. 1 st. EOR 22x, 1 st. EVERY ROW 53x.
Bind off remaining sts.

OUTSIDE PANELS: Make 2.

Follow Chart and make in same way as END PANELS.

FINISHING:

Join Lace strips to Motif strips. Join outside Panels. (See drawing).

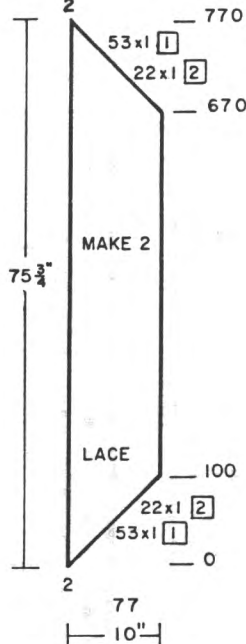
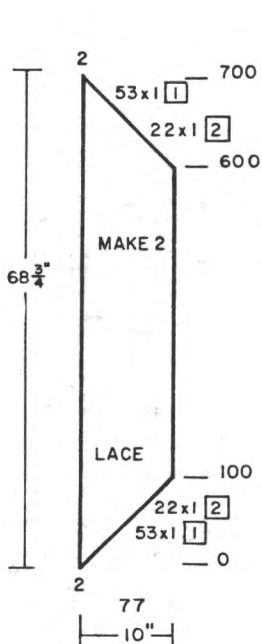

ASSEMBLY DIAGRAM

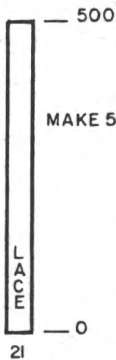
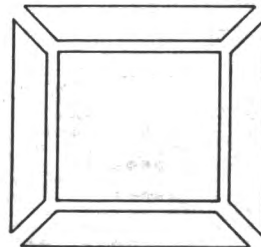

MAKE 5 LACE PANELS: Make 5, T 4

W.Y. cast on 21 sts. After several rows end with 1 row Ravel Cord to the right. Counter 0. Change to Col. 1 (1 strd Glace and 1 strd thread together). 'e' cast on over the Ndl. Knit 2 rows then begin Lace Pattern. After R 500, bind off.

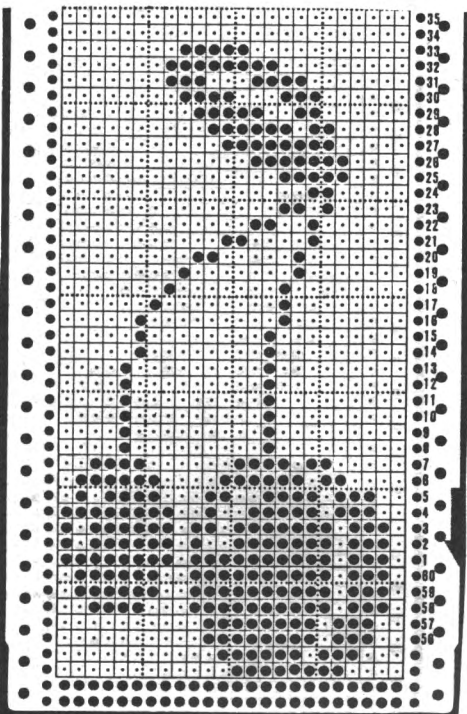
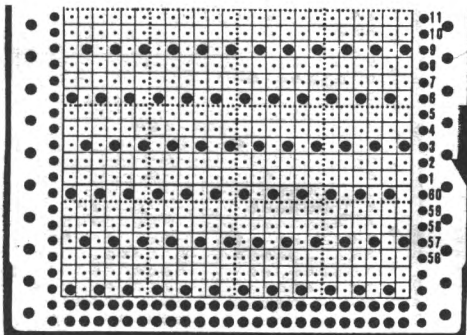

600

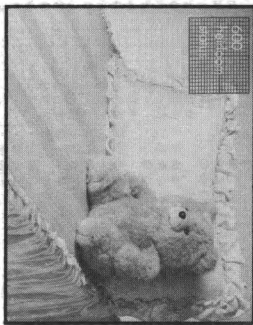

Using 1 strd. Glace and 2 strds thread - 'e' cast on 78 sts. Knit 1 row, Carr on left past Sensor. Set Carr. to KC II. Knit 1 row left to right to select Ndl. Remove the 2 strds of thread from Feeder A and place in Feeder B. Set Carr. for Thread Lace (Push both MC & L Buttons). Continue in Thread Lace Pattern. After R 856, bind off.

BEDSPREAD WITH PILLOW SHAM

SIZE: For Single Bed.
YARN: Glace and Sewing Thread
AMOUNT: Glace - 5 Cones
Sewing Thread - 1200 yd. spools ----- 13 Spools.
TENSION: T 4
GAUGE: 14 sts. 22.5 rows = 2"
Make on the KH 930 machine.
Thread Lace Design is Pat. 406 from Pattern Book.

BEDSPREAD: SIDE PANEL - Make 2.

Use 1 strand Glace as Main yarn and 2 strands of Thead in Feeder B.
PROGRAM:
Machine on - Green Ready Light ON.
Press Selector 2, Variation Key 2
Press Step
Press CE and enter Pat. No. 406
Press Step
Enter 2
Press Step
Press Step
Enter 0
Press Step and Green ready light is on.

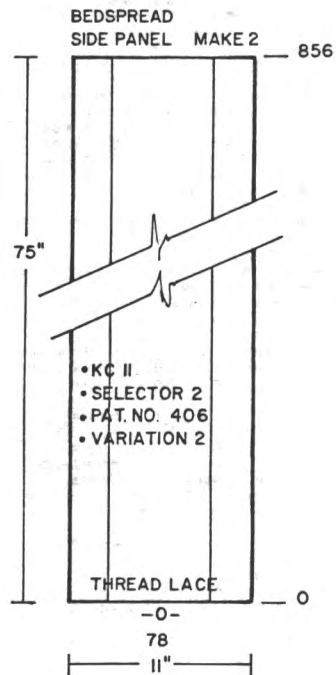

BEDSPREAD CENTER PANEL- Make 1.
 Use 1 strd. Glace as main yarn and 2 strds of thread in Feeder B for Thread Lace Pattern.

PROGRAM:
 Machine on - Green Ready light on.
 Press Selector 2, Variation Key 2
 Press Step
 Press CE and enter Pat No. 406
 Press Step
 Enter 2
 Press Step
 Press CE
 Press Orange Key
 Enter 63
 Press Step
 Enter 2
 Press Step
 Press Green Key
 Enter 18
 Press Step
 Enter 0
 Press Step - Green Ready Light on.
 Cast on 156 sts. same as for Side Panels.
 Knit to R 856. Bind off.

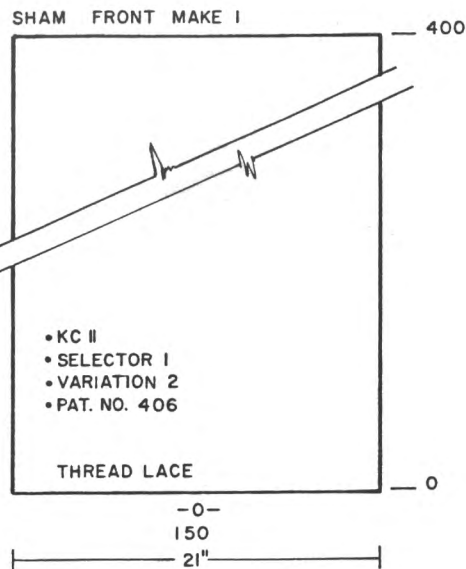
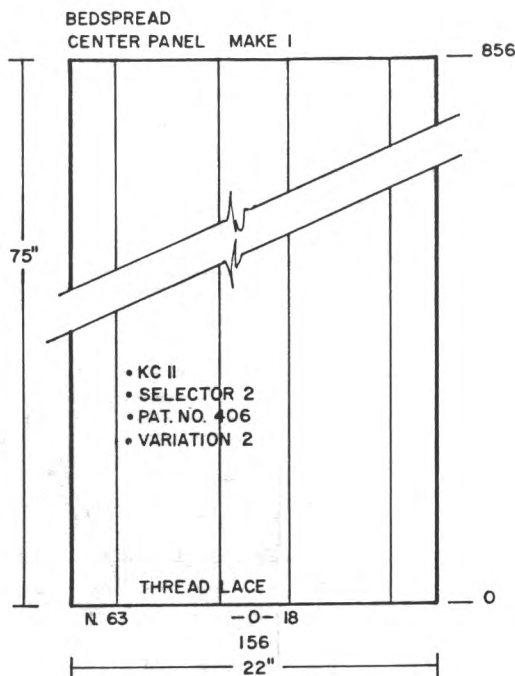

PILLOW SHAM FRONT: Make 1

Use 1 strd. Glace for main yarn and 1 strd of Thread in Feeder B for Thread Lace Pattern.

PROGRAM:
 Use Selector 1 and Variation Key 2.
 Program Pat. 406.
 Cast on 150 sts. same as you did before and knit in Thread Lace Pattern to R 400. Bind off.

BEDSPREAD RUFFLE: Make 1

Use 1 strd Glace for main yarn and 1 strd. thread in Feeder B for Thread Lace Pattern.

PROGRAM:
 Machine on - Green Ready Light on.
 Press Selector 2, Variation 2.
 Press Step
 Press CE and enter Pat. No. 406
 Press Step
 Enter 2
 Press Step
 Press CE
 Press Yellow Key
 Enter 63
 Press Step
 Enter 0
 Press Step - Green Ready Light on.
 Cast on 130 sts. same as before and Knit in Thread Lace Pattern.
 After Row 4,000, bind off.

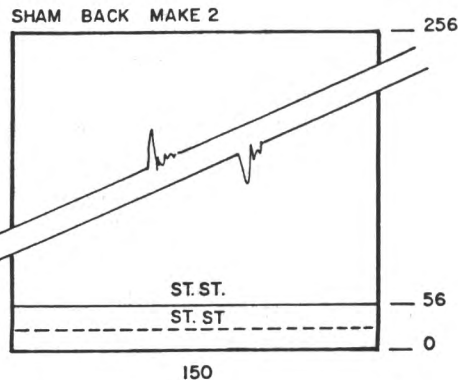
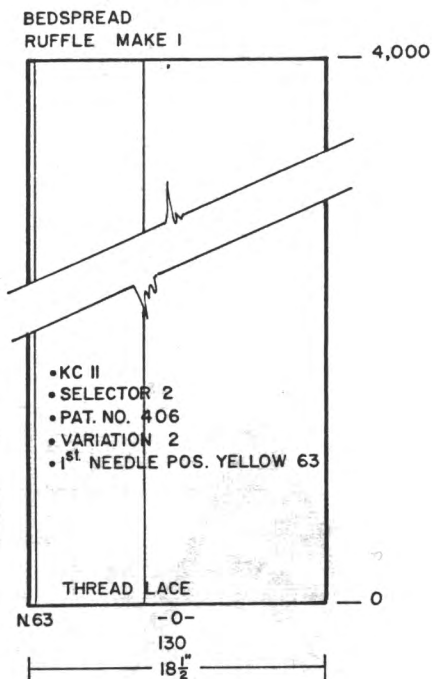

PILLOW SHAM BACK: Make 2.

Use 1 strd. Glace for Main yarn and 1 strd of Thread in Feeder B for Thread Lace Pattern.

'e' cast on 150 sts. and using T 3 knit 56 rows in St. st. Pick up first row to form hem. Continue in St. st. to R 256. Bind off.

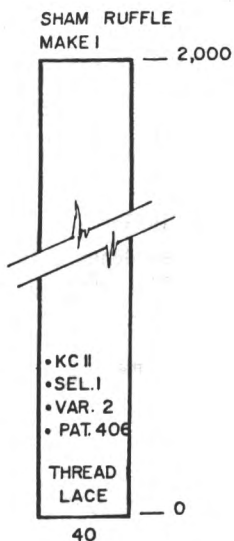

SHAM RUFFLE:

Use 1 strd Glace and 2 strds Thread for Thread Lace Pattern.

PROGRAM:
 Use Selector 1 and Variation Key 2.
 Program Pattern No. 406.
 'e' cast on 40 sts. and knit 2000 rows. Bind off.

FINISHING:

A sewing machine is the easiest to use for assembly, but hand stitching would also provide a beautiful finish. Sew Panels together. Gather the Ruffle for spread and pin to 3 edges (omit the top edge). Allow extra fullness at corners. Sew Pillow Sham pieces together, overlapping the two sections of back. Gather and sew Ruffle around all edges. Insert a King size pillow in opening. You can sew pieces of Velcro to back opening of pillow sham.

601

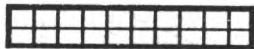

WOMENS PULLOVER

(Not for beginners)
Make Sample Swatch first.

SIZES: One size fits 6 to 16

YARN: Col.1 = White Angora
Col.2 = 2 Strds. Grey Glace +
1 Strd. Grey Regular
Venetia Knit together.

AMOUNT:

Col.1 Angora 16 Balls
Col.2 1 Cone Glace and 12 oz.
Venetia
Col.3 Angora 9 Balls

TENSION: St. st. 3 Rib. 0/0 II
GAUGE: 8 1/2 sts. 12 1/2 R = 2"
Optional - Beaded Tassel

Make on any Bulky machine with
Ribber. Body of Pullover is knitted
using Short Row method. Bands are
K1, P1 Ribbing.

CHART SHOWS SECTIONS. This is the
order in which we knit the garment.
If you want an enlarged copy of
Chart, send \$1.00 and a large size
self addressed, stamped envelope.

SECTION 1: COLOR 1.

Starting at Nd1. 45 to the right of
0, W.Y. cast on 57 sts.
After several rows, end with 1 row
Ravel Cord to the LEFT. Counter 0.
Change to Col. 1, knit 2 rows.
*CARRIAGE ON LEFT. ON OPPOSITE SIDE
OF CARR. bring 1 Nd1. to HP, knit
1 row. (ALWAYS WRAP INSIDE NEEDLES
TO PREVENT HOLES WHEN KNITTING
SHORT ROWS). Knit 1 row.
REPEAT FROM * for a total of
48x (SEE CHART). BUT AT THE SAME
TIME, after R 82 (Carr. on right)
ON OPPOSITE SIDE OF CARR., bring
to HP 1 st. 7x. Break yarn.
Turn Counter back to 2.

SECTION 2: COLOR 2.

Carriage is on the RIGHT.
Push 1 Nd1. to WP, knit 2 rows.
Push 1 additional Nd1. to WP,
knit 2 rows.
Push 1 additional Nd1. to WP,
knit 1 row. (Carr on the LEFT.)
*On extreme RIGHT, bring 1 Nd1.
to HP, knit 1 row (Carr. on RIGHT)
ON OPPOSITE SIDE OF CARR. push
back to WP 1 Nd1. Knit 1 row to
the left.
REPEAT FROM * TO *.
After R 98 Section 2 is completed.

SECTION 3. COLOR 2

Set Counter at 82.
ON THE LEFT, hang 33 sts. from
a "Cast on Rag" (See Practical

Knitting Hints this issue), then
with Color 2, 'e' cast on over
these Ndls. BRING ALL NDLS. TO
HP.
Push 2 Ndls. to WP and begin

section 3. FOLLOWING CHART,
complete sections in NUMERICAL
ORDER, BUT AT THE SAME TIME, after
R 120, mark for Neck opening.
After R 152, mark for center of
Garment and REVERSE SHAPING.
After R 184, mark for Neck opening.
After R 221, BIND OFF 33 sts.
Continue Sleeve and after R 304.
bind off.

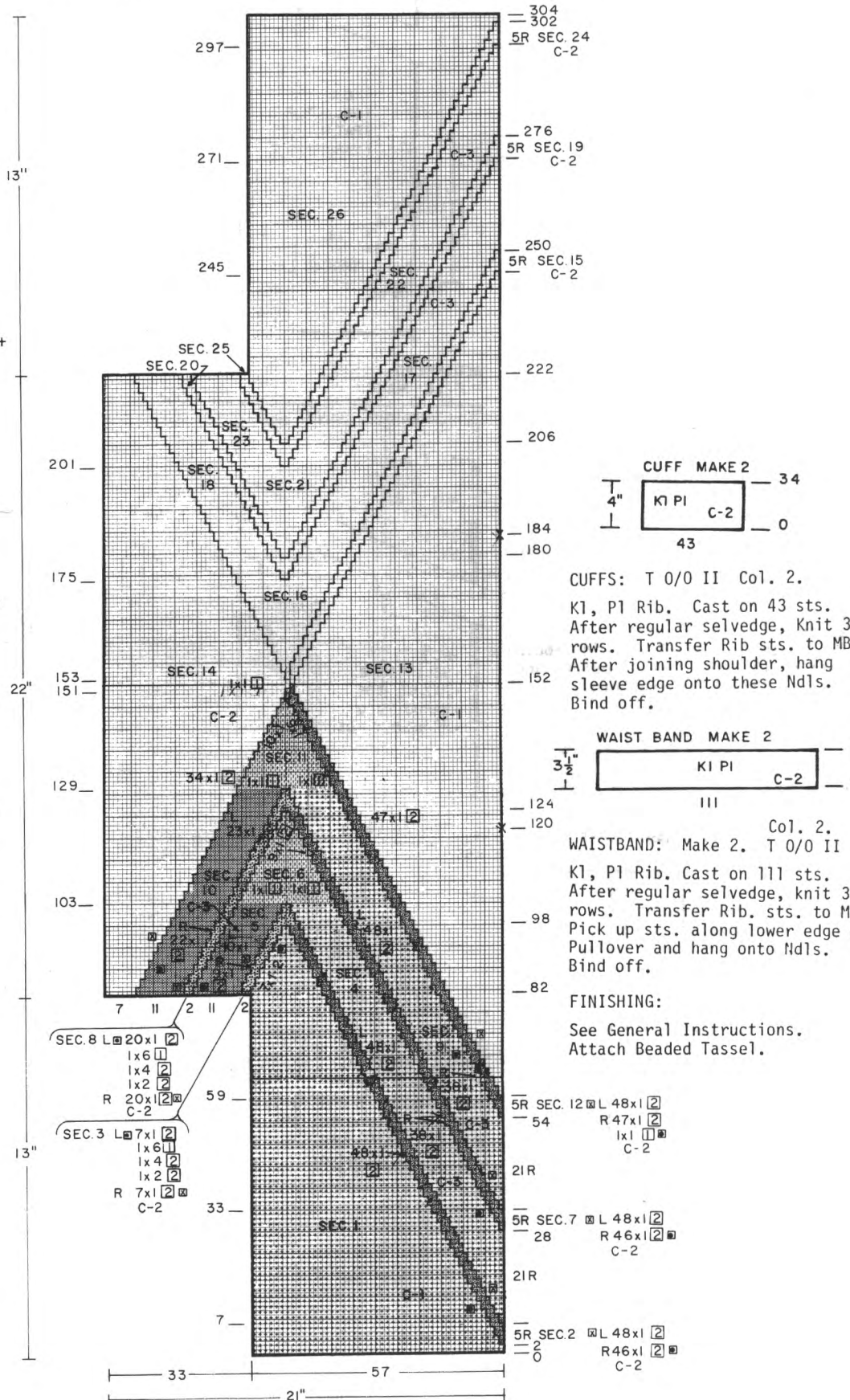



WOMENS SAILOR DRESS

SIZES: 6/8 (10/12) [14/16]
 YARN: Roma
 AMOUNT:
 Col. 1 32 oz. 33 oz. 34 oz.
 Col. 2 2 oz. for all sizes
 TENSION 4.1 St. st. Rib. 4/3.2 I
 GAUGE: 16 sts. 24 rows = 2"

Make on any Standard Machine with Ribber.
 Notions: Snap Fastener & Narrow Elastic

SKIRT: Make 4 Panels

FNR: With Col. 1, cast on 133 (144) [155] sts. using T 4/3.2 II. After regular selvedge, transfer the specified sts. as shown on the Chart for Rib Pattern. Set Carr. to regular Rib - T 4/3.2 I. Knit to R 192 (200) [208]. Transfer Rib sts. to MB, knit 1 row then remove on W.Y. Weave 2 Panels together for front/back.
 CASING FOR ELASTIC. Bring 156 (164) [172] Ndls. to WP. With wrong side facing and following Chart for doubling or tripling sts. hang skirt sts. held on W.Y. onto these Ndls. Bring Ribber up to WP (Pitch H) Knit 1 row over all sts. then HANG CAST ON COMB set MB Carr. and Ribber Carr. so you knit 4 rows MB ONLY 2 rows on RIBBER ONLY. Transfer Rib sts. to MB * Drop Ribber and knit 10 Rows St. st. REPEAT FROM * TO *. Knit 1 row St. st. then remove on W.Y. Weave other 2 Panels together and REPEAT CASING FOR ELASTIC.

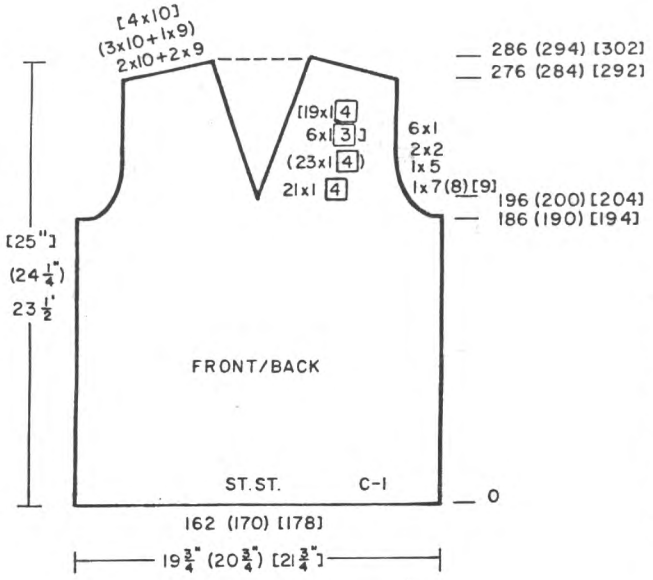
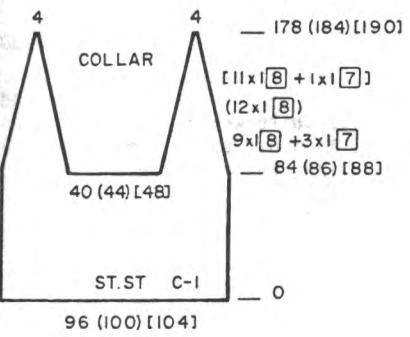

WAIST BAND/CASING

FNR	C-1	4R/2R
ST. ST.	C-1	10R
FNR	C-1	4R/2R

156 (164) [172]

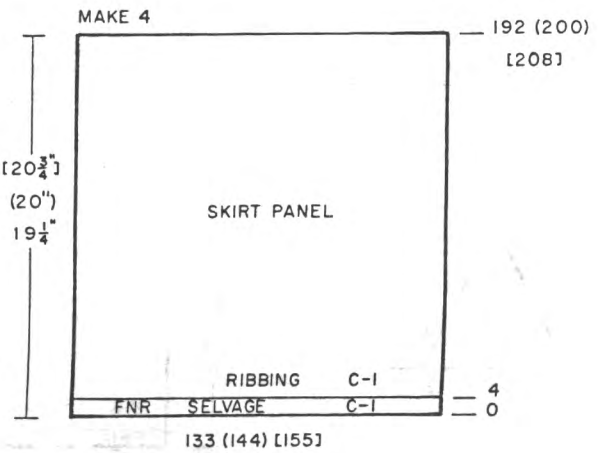

COLLAR:

W.Y. cast on 96 (100) [104] sts. After several rows end with 1 row Ravel Cord to the right. Change to Col. 1, Counter 0. Continue in St. st. After R 84 (86) [88] bind off the center 40 (44) [48] sts. Place sts. on left to holding position and complete the right side first. *ON EACH SIDE, dec. 1 st. every 8th row 9x, 1 st. every 7th row 3x. (1 st. every 8th row 12x) [1 st. every 8th row 11x, 1 st. every 7th row 1x]. After R 178 (184) [190], bind off remaining sts. Bring sts. on left back to WP, turn Counter back to 84 (86) [88] and complete left half. Follow instructions from *.

FRONT:

Bring 162 (170) [178] Ndls. to WP. Hang the open sts. of Casing onto these Ndls. pulling up yarn between sts. to make up for missing sts. Counter 0. Color 1. Continue in St. st. After R 186 (190) [194], SHAPE ARMHOLE: ON EACH SIDE, BO 7 (8) [9] sts. 1x, 5 sts. 1x, 2 sts. EOR 2x, 1 st. EOR 6x, BUT AT THE SAME TIME, after R 196 (200) [204], divide in the Center for V Neck-shaping. Place sts. on left to holding position and complete the right side first. *ON NECK EDGE, dec. 1 st. every 4th row 21 (23) [1 St. Every 4th Row 19x, 1st. Every 3rd Row 6x.] After R 276 (284) [292], SHAPE SHOULDER: BO or you can use Short Row method, 10 sts. 2x, 9 sts. 2x (10 sts. 3x, 9 sts. 1x) [10 sts. 4x]. Bring sts. on left back to WP, turn Row Counter back to 196 (200) [204] and complete left half. Follow instructions from * but DO NOT FORGET Armhole Shaping.

BACK:

Work back same as Front but OMIT NECK SHAPING. After R 286 (294) [302] mark for Neck opening with W.Y. then remove onto W.Y.

SLEEVES:

With W.Y. cast on 92 (100) [106] sts. After several rows end with 1 row Ravel cord to the right. Counter 0, change to Col. 1. Continue in St. st. ON EACH SIDE, inc. 1 st. every 16 rows 10 (10) [11]x. After R 172 (176) [180], SHAPE SLEEVE CAP: FOLLOW CHART FOR YOUR SIZE. After R 250 (258) [266], bind off remaining sts.

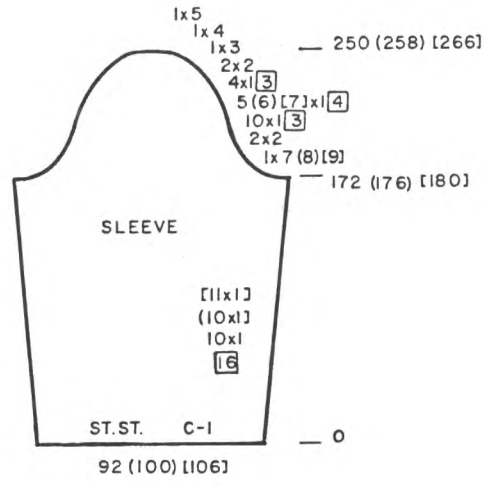

SLEEVE CUFF: Make 2

Bring to WP 52 (56) [60] Ndl's. With wrong side facing, hang the open sts. of sleeve onto these Ndl's, decreasing evenly across. Follow Color Chart for changes in color. After R 46, pick up first row of Cuff to form hem then bind off.

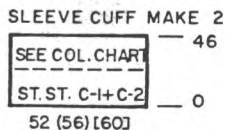

COLLAR BACK TRIM:

W.Y. cast on 82 (86) [90] sts. After several rows end with 1 row Ravel Cord to the right. Change to Col. 2. Counter 0. Begin Stripe Pattern (See Chart). ON EACH SIDE, inc. 1 st. EOR 7x, then decrease 1 st. EOR 7x. After Row 34, pick up first row to form hem. With WRONG SIDE FACING, hang open sts. of Collar onto these Ndl's, decreasing evenly across. Bind off.

COLLAR SIDE TRIM: Make 1, reverse 1.

W.Y. cast on 118 (122) [126] sts. same as back trim. Change to Col. 2. Counter 0. Begin the Stripe Pattern. ON LEFT SIDE (right for 2nd section) inc. 1 st. EOR 7x, then dec. 1 st. EOR 7x. After R 34 pick up first row to form hem. With WRONG SIDE FACING, hang side of Collar onto these Ndl's. Bind off.

CUFF COL. CHART 46

C-2	5R
C-1	2R
C-2	4R
C-1	2R
C-2	4R
C-1	2R
C-2	8R
C-1	2R
C-2	4R
C-1	2R
C-2	4R
C-1	2R
C-2	5R

BIB & COLLAR COL. CHART 34

C-2	5R
C-1	2R
C-2	4R
C-1	2R
C-2	8R
C-1	2R
C-2	4R
C-1	2R
C-2	5R

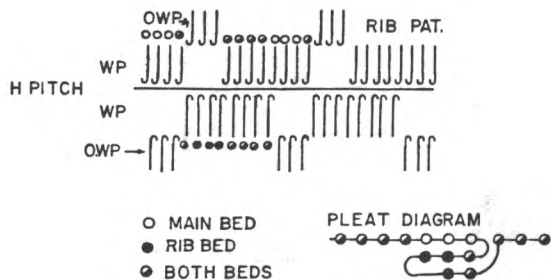

602 B

CHILDS SAILOR DRESS

SIZES: 2/4 (6/8)
YARN: Roma
AMOUNT:
Col. 1 16 oz. all sizes.
Col. 2 2 oz. all sizes.
TENSION: St. st. 4.1 Rib 4/3.2 I.
GAUGE: 16 sts. 24 rows = 2"
Notions: Narrow Elastic & Snap Fastener.

Make on any Standard Machine with Ribber.

SKIRT: Make 2 sections.

FNR: With Col. 1, cast on 166 (177) [188] sts. using T 4/3.2 II. After regular selvedge, transfer the specified sts. as shown on the Chart to form Rib Pattern same as for Womens size. Set Carr. to regular Rib - T4/3.2 I. Continue in Rib Pattern. After R 70 (78) [86], transfer Rib. sts. to MB and remove on W.Y.

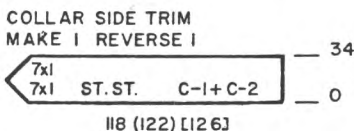
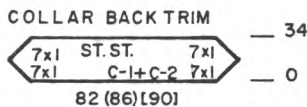

BIB:

W.Y. cast on 58 (60) [62] sts. same way as before. Change to Col. 1, Counter 0. ON EACH SIDE, dec. 1 st. every 3rd row 25 (26) [27]x. After Row 76(80)[84] Bind off Remaining Sts.

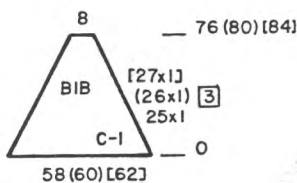

BIB TRIM:

W.Y. cast on 52(54)[56] Change to Col 2. Counter 0. Follow Stripe Chart for Collar Trim. After R 34, pick up first row to form hem. With WRONG SIDE FACING, hang open sts. of Bib onto these Ndl's. Bind off.

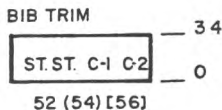

BOW:

FNR: With Col. 2, cast on 12 sts. After regular selvedge, continue with Carriage Controls on same settings and in Circular knitting knit 300 rows. Transfer Rib sts. to MB and BO.

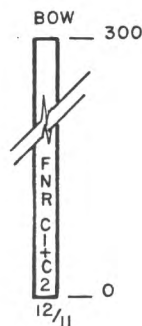

FINISHING:

See General Instructions.

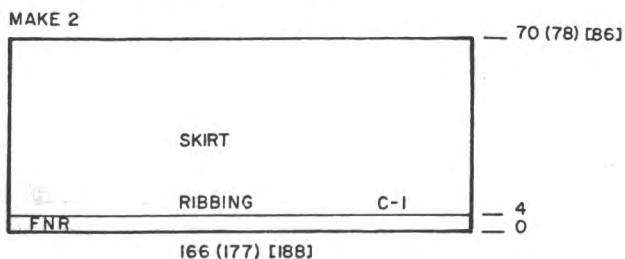

WAIST BAND/CASING

FNR	4R/2R
ST. ST.	10R
FNR	4R/2R
98 (106) [114]	

CASING:

Bring 98 (106) [114] Ndl's. to WP. Using the same technique for doubling sts. as in the womens dress, rehang open sts. of Skirt panel onto these Ndl's. *Bring Ribber up to working position. Knit 4 rows MAIN BED ONLY. Change Carriage setting and knit 2 ROWS RIBBER BED ONLY. Transfer Rib sts. to MB* Knit 10 rows St. st. REPEAT FROM * TO * Knit 1 row Sts. st. then remove on W.Y.

BODICE FRONT:

Bring 106 (114) [122] Ndl's. to WP. Hang the open sts. of Casing onto these Ndl's, pulling up a loop where needed to fill in the difference in amount of sts. With Col. 1, continue St. St. Counter 0. After R 100 (104) [108] SHAPE ARMHOLE: ON EACH SIDE, B0 6 sts. 1x, 3 sts. 1x, 2 sts. 1x, 1 st. 5x BUT AT THE SAME TIME, after R 108 (112) [116], divide in the center for 'V' neck shaping. Place sts. on the left to holding position and complete right side first.

*ON NECK EDGE, dec. 1 st. every 3rd row 10 (11) [12]x, 1 st. every 4th row 7x. After R 164 (172) [180] SHAPE SHOULDER: Bind off or use Short Row Method, 5sts. 4x (5 sts. 3x, 7 sts. 1x) (6 sts. 4x). Bring sts. on left back to WP, Counter back to 108 (112) [116] and complete left half. Follow instructions from *.

SLEEVES:

WY cast on same as you did before ending with 1 row Ravel Cord to the right. Counter 0. Change to Col. 1 and continue in St. st. ON EACH SIDE, inc. 1 st. every 6th row 17x. After R 104 (108)[112] SHAPE SLEEVE CAP: ON EACH SIDE, dec. 1 st. EOR 20x, then bind off 2 sts. 1x, 3 sts. 1x, 4 sts. 1x, 5 sts. 2x. After R 154 (162) [170] bind off remaining sts.

SLEEVE CUFFS:

Bring 46 (54) [62] Ndl's. to WP. Hang the open sts. of sleeve onto these Ndl's. Follow Color Chart and knit St. st. to R 34. Pick up first row of cuff to form hem. Bind off.

COLLAR:

W.Y. cast on same as you did before, 62 (66) [70] sts. After Ravel Cord row, change to Col. 1. Counter 0. Knit St. st. to R 54 (56) [58]. Bind off center 32 (34) [36] sts. Place sts. on left to holding position and complete right side first. *ON EACH SIDE, dec. 1 st. every 10th row 6x (1 st. every 10th row 6x) [1 st. every 10th row 7x]. After R 120 (126) [130] B0 remaining sts. Bring sts. on left back to WP. Turn Counter to 54 (56) [58] and complete left half. Follow instructions from *.

COLLAR TRIM:

W.Y. cast on same as before 56 (60) [64] sts. After Ravel Cord row, change to Garment yarn and follow Color Chart for Stripe Pattern. ON EACH SIDE, inc. 1 st. EOR 4x, then dec. 1 st. EOR 4x. After R 22, pick up first row to form hem. WITH WRONG SIDE FACING, hang open sts. of Collar onto these Ndl's., decreasing evenly across. Bind off.

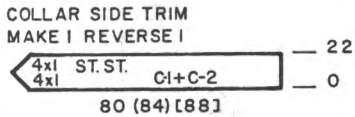
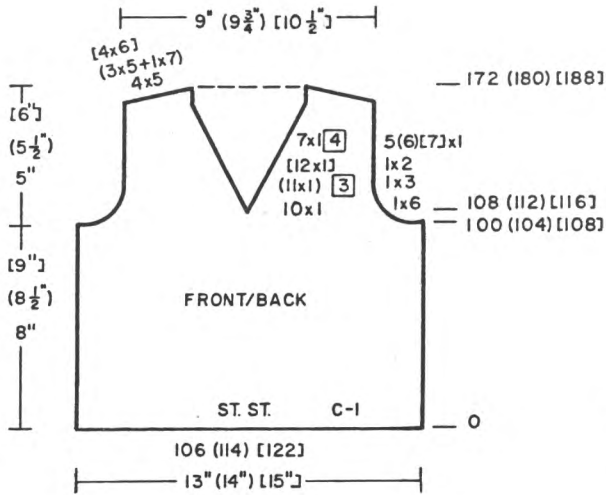

COLLAR SIDE TRIM: Make 1, reverse 1.

W.Y. cast on same as before 80 (84) [88] sts. After Ravel Cord row, change to garment yarn and follow Color Chart for Stripe Pattern. ON THE LEFT (RIGHT for second section), inc. 1 st. EOR 4x, then dec. 1 st. EOR 4x. Pick up first row to form hem. WITH WRONG SIDE FACING, hang side edge of Collar onto these Ndl's. spacing evenly across. Bind off.

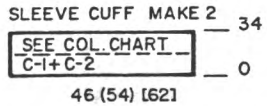
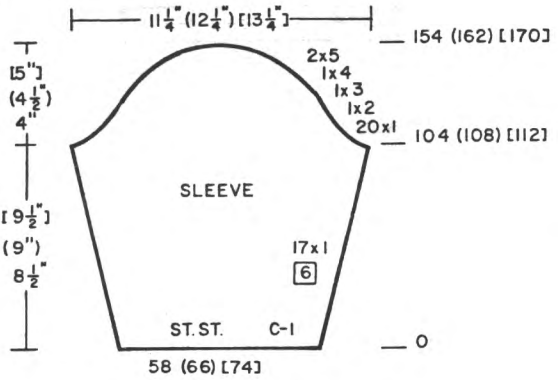

CUFF

COL. CHART	34
C-2	5R
C-1	2R
C-2	4R
C-1	2R
C-2	8R
C-1	2R
C-2	4R
C-1	2R
C-2	5R

BIB & COLLAR

COL. CHART	22
C-2	5R
C-1	2R
C-2	8R
C-1	2R
C-2	5R

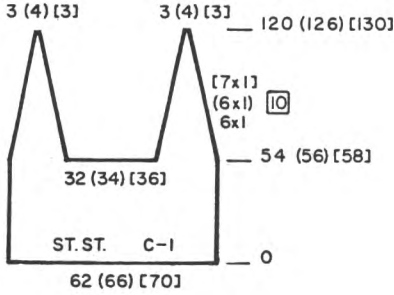
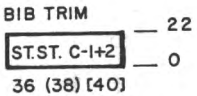
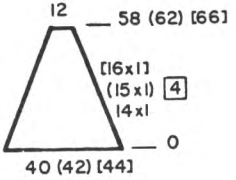

BIB:

W.Y. cast on same as before 40 (42) [44] sts. After Ravel Cord row, change to Col. 1, Counter 0. Continue St. st. ON EACH SIDE, dec. 1 st. every 4th row 14 (15)[16]x [16]x. Bind off remaining sts. After Row 58(62)[66] BIND OFF REMAINING STS.

BIB TRIM:

W.Y. cast on same as before. 36 (38) [40] sts. After Ravel Cord row, change to garment yarn and knit 22 rows. Pick up first row to form hem. With wrong side facing, hang open sts. of Bib onto these Ndl's. then bind off.

BOW:

FNR: With Col. 2, cast on 9 sts. Knit in same manner as Womens Bow. After R 240, B0.

FINISHING:

See General Instructions.

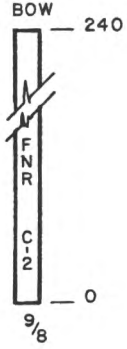
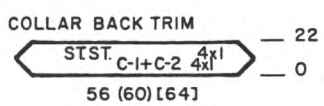

603



After R 157 (167) inc. 1 st. EOR 9 (10)x then cast on 2 sts. After R 228 (244) Bind off 30 (31) sts. then on arm side, decrease 1 st. every 4th row 14 (15)x. After R 288 (308) remove the remaining sts. on W.Y.

Work the second section with cast on to the RIGHT OF 0. To make it easy for you, have EVEN ROW NUMBERS ON THE LEFT, as you will be cast on the 30 (31) sts. on the LEFT and working the Short Row Designs from the LEFT SIDE, then shaping the neckline on the RIGHT SIDE.

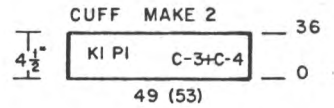

CUFFS:

Join both shoulders. K1, P1 Rib: With 1 strand Col 3 and 1 strd. Col. 4 together, cast on 49 (53) sts. After regular selvedge, knit 36 rows. Transfer Rib sts. to MB. With Purl side facing, hang sleeve edge onto these Ndl. decreasing evenly across. Bind off LOOSELY.

WOMENS PULLOVER

SIZES: 12/14 (16/18)

YARN: Col. 1 = Pebble
Col. 2 = Angora
Col. 3 = Bulky Venetia
Col. 4 = Glace

AMOUNT:
Col. 1 20 oz. 24 oz.
Col. 2 6 6 balls
Col. 3 6 oz. 6 oz.
Col. 4 2 Spools both sizes.

TENSION: St. st. 5, Rib 0/0 II
GAUGE: 7 sts. 13 rows = 2"

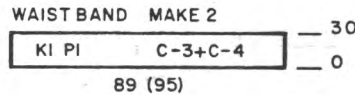

WAISTBANDS: Make 2.

K1, P1 Rib: With 1 strd Col. 3 and 1 strd. Col. 4, together, cast on 89 (95) sts. After regular selvedge, knit 30 rows. Transfer Rib sts. to MB. With Purl side facing, hang waist onto these Ndl. decreasing evenly across. Bind off LOOSELY.

Make on Bulky machine using Short Rows for the design. You can also make it using the Intarsia method if you own a Bulky machine with Intarsia setting or own an Intarsia Carriage. The bands are K1, P1 Ribbing.

FINISHING:

Close side seams. With 1 strd Col. 3, single crochet 1 row around Neck edge. With Col. 2 (Angora) Work 3 rows single crochet around neckline.

FRONT/BACK: Make 1, Reverse 1

W.Y. cast on 34 (36) sts. to the LEFT OF 0. After several rows end with 1 row Ravel Cord to the right. Change to Col. 1. Counter 0. Work St. st. AND AT THE SAME TIME, ON THE RIGHT SIDE, inc. 1 st. every 4th row 14 (15)x. After R 60 (64) ON THE RIGHT, cast on 30 (31) sts. After R 72 (80) knit across to the LEFT and begin SHORT ROW DECREASES. Place 58 (60) sts. on the RIGHT (left for second section) to holding position. knit 2 rows (don't forget to wrap inside Ndl. when knitting short rows to prevent a hole).

ON THE RIGHT, bring 1 st. to holding EOR 5x. DO NOT COUNT THESE SHORT ROWS. Break yarn and MOVE CARRIAGE TO THE RIGHT SIDE. Counter. at 72 (80)

Work INCREASE SHORT ROWS with Col. 2. PUSH BACK TO WP 58 (60) sts. and the remaining sts. to the left of these in holding position. Knit 2 rows then push back to WP 1 st. EOR 5x. With Col. 1, knit 12 rows.

NOW FOLLOW THE CHART FOR THE REMAINING SECTIONS, WORKING THE DECREASE SHORT ROWS FIRST and then the INCREASE SHORT ROWS using the SPECIFIED NUMBER OF STS. AS SHOWN ON THE CHART. BUT AT THE SAME TIME, AFTER ROW 111 (119), SHAPE NECK ON THE LEFT.

Bind off 2 sts. 1x, then decrease 1 st. EOR 9 (10) times. After R 144 (154), mark each side for center of garment.

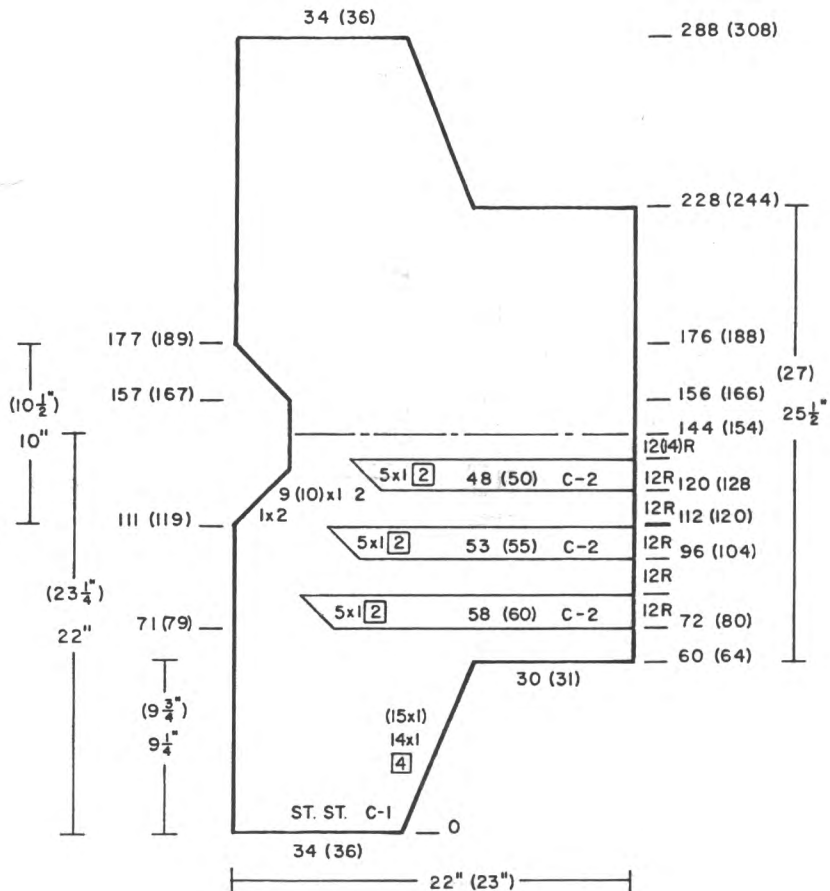

604

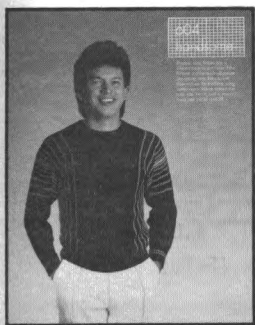

YOUNG MENS PULLOVER
 SIZES: 14/16 (34/36) [38]
 YARN: Venetia
 AMOUNT:
 Col. 1 14 oz. 15 oz. 16 oz.
 Col. 2 2 oz. all sizes
 Col. 3 2 oz. all sizes
 TENSION: St. st. 5, Rib. See Instructions.
 GAUGE: St. st. 16 sts. 26 rows = 2"

STRIPE CHART	
STRIPE	2R
C-1	12R
STRIPE	2R
C-1	10R
STRIPE	2R
C-1	8R
STRIPE	2R
C-1	6R
STRIPE	2R
C-1	4R
STRIPE	2R
C-1	2R
STRIPE	2R

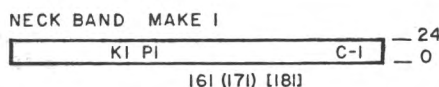
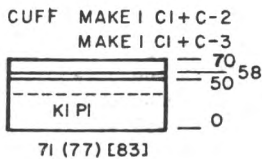
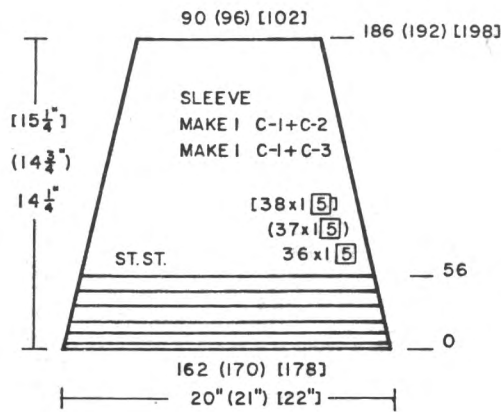

SLEEVES: Make 1 Col.1 & 3
 Make 1 Col. 1 & 2

Pick up Sts. from edge of Front and Back Bodice. 162 (170)[178] Sts.
 Work the color Stripes as shown on Chart and AT THE SAME TIME, On EACH SIDE, dec. 1 St. every 5th Row 36(37) [38]x.
 After R 186(192)[198] remove on W.Y.

CUFFS: Make 2

K1, P1 Rib: With Col. 1, Cast on 71 (77) [83] sts. T 1.1/1.1 II
 After R 50, knit 2 rows Col. 2 (Col. 3 for second sleeve Cuff).
 After R 58, knit 2 rows Col. 2 (Col. 3 for second Cuff).
 After R 70, transfer Rib sts. to MB and with KNIT SIDE FACING (wrong side), hang sleeve edge onto these Ndl. decreasing evenly across. Bind off.

NECKBAND: Close one Shoulder first.

K1, P1 Rib: With Col. 1, cast on 161 (171) [181] sts. T 1.2/1.2 II
 Knit 24 rows. Transfer Rib sts. to MB. Hang neck edge onto these Ndl. Bind off.

Make on any standard Machine with Ribber. Knitted sideways on machine with color stripes as shown. The Purl side is the right side.

BACK:

W.Y. cast on 172 (180) [188] sts. After several rows end with 1 row Ravel Cord to the right. Change to Col. 1, Counter 0. Knit 1 row to the left. Mark with W.Y. for sleeve opening. (See Chart). Knit 1 row to the right then continue in St. st. with color stripes as shown on the Chart. (Col.1&2)
 After R 86 (92) [98] SHAPE NECK: Bind off 4 sts. 1x, 2 sts. 1x, 1 st. 3x.
 After R 138 (150) [162], inc. 1 st. 3x, 2 sts. 1x, 4 sts. 1x,
 After R 178 (196) [214] work the Color Stripes as shown on the Chart. (Col. 1 & 3).
 After Row 234 (252) [270] mark for sleeve opening then BO or remove on W.Y.

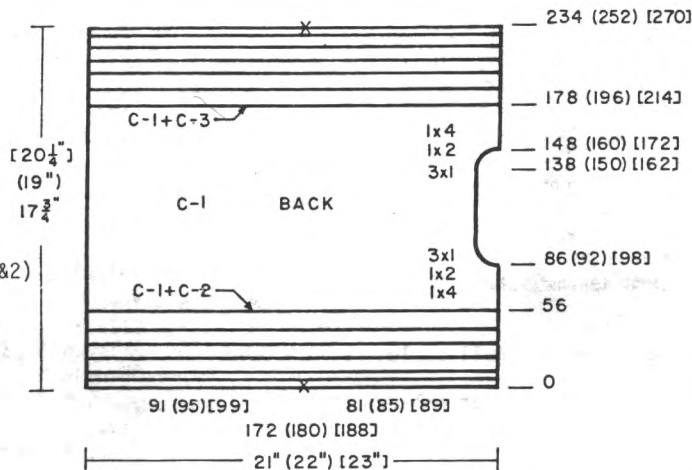

FRONT:

W.Y. cast on 172 (180) [188] sts. same as back. Change to Col. 1, Counter 0. Knit 1 row to left and W.Y. mark for Sleeve opening. Knit 1 row to the right. Change to Col. 3 and follow the Chart for the color stripes with Col. 1 and Col. 3.
 After R 86 (92) [98] SHAPE NECK: Bind off 8 sts. 1x, 5 sts. 1x, 3 sts. 1x, 2 sts. 4x, 1 st. 2x.
 After R 130 (142) [154] ON NECK EDGE, inc. 1 st. 2x, cast on 2 sts. 4x, 3 sts. 1x, 5 sts. 1x, 8 sts. 1x.
 After R 178 (196) [214] begin the Col. Stripes as shown on the Chart with Col. 2 and 1. After R 234 (252) [270] BO or remove on W.Y.

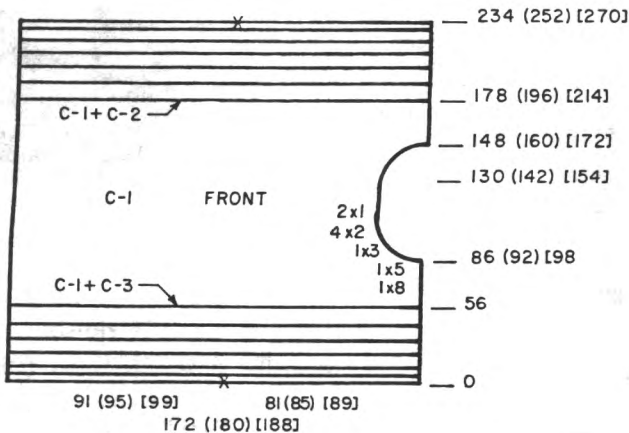

COMPLETE GARMENT DIAGRAM

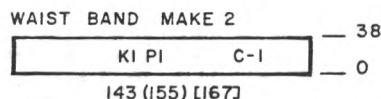
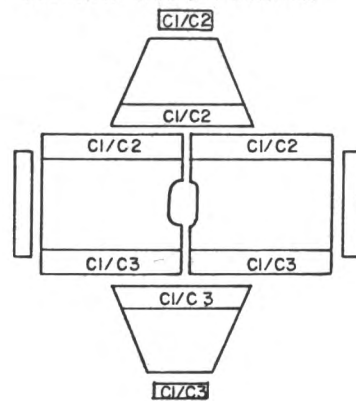

WAISTBAND: Make 2. T 1.1/1.1 II

K1, P1 Rib: With Col. 1, cast on 143 (155) [167] sts. T 1.2/1.2 II
 Knit 38 rows. Transfer Rib sts. to MB. Hang lower edge of Front/Back onto these Ndl. Bind off.

FINISHING:

See General Instructions.
 Fold Neckband and Sleeve Cuff to the inside and stitch in place.



PRACTICAL KNITTING HINTS

The Angora sweater No. 601 in this issue is knitted sideways on the machine and you need to cast on 33 sts. at the underarm. An easy way to do this is to make a separate knitted piece in stockinette stitch (sometimes called a cast-on rag) and if you knit it in stripes, you simply follow a row across and hang onto the machine. Knit a row of Ravel Cord (you can pull this out later and still have your cast-on rag for future use). Now with garment yarn, 'e' cast on the 33 sts. This way you can hang weights to hold your knitting down and no problems while you continue your knitting.

KNIT 1 ROW ACROSS DOUBLE OR TRIPLE STITCHES

Many times you will hang a hem or will need to double or triple stitches on one needle, then bind off. It can be difficult to bind off through multiple stitches and although we usually do not tell you to knit 1 row over multiple stitches (because some experts do not like this extra row) you can bring all needles to holding position and SLOWLY knit 1 row over all stitches. This actually makes it easier for you to make your bind-offs. If too many stitches are on one needle, knit this one row by hand to be sure that the sts. knit off.

HIDDEN PATTERNS IN THE COMPUKNIT III

Many have called in to share the finding of Patterns in the COMPUKNIT III (KH 930) computer that are not in the regular Pattern Book that comes with the machine. Here is a list of the ones reported so far. The Alphabet "Capital Letters" No's 601 through 626. Use Variation Key #1. The Alphabet "small letters" No's 627 through 652. Miscellaneous. We were told to use Variation Key #5 (upside down key) for the following but found it not to be true. Maybe it changes from one machine to another. Experiment!! 653 - 2 st. 2 row DOT. 701 - Advertising for 'Brother'. 702 - KH 930 - and then there are a few we have not had the time to make a sample of, so we are not sure what they are. # 703, 881, 882, 883, 884.

"MY 910 DOES A & B PATTERNS , AND THE 930 DOESN'T"

HOW MANY TIMES HAVE YOU HEARD that Statement. The statement is correct, but not to worry. The COMPUKNIT III (930) , by adding to, or deleting from, a Mylar Sheet Pattern accomplishes the SAME END RESULT.

For Example: Pattern 573 in our last Issue. Vol. 21 No. 1. You will see a Mylar sheet in small scale. and this gives you many clues.

60 Sts. wide and 60 Rows high. On the 930 you must enlarge this to get the total width of 152 (160) Sts. This becomes Pattern No. 2. This done by adding 2 Sts. to the left (this to compensate for the 74(78) Settings in the Diagrams or Houses in the 910 Pattern. On the Right we add 90(98) Sts.

Now we have a pattern 152(160) Sts. Wide and 60 Rows High. INPUT: 152(160) Sts.
60 Rows.

Row 1. Start in lower left hand corner. Program 'Blank' 'Dot' then the Bottom row from Mylar sheet Drawing then 'Blank' 'Dot' etc across the remaining Program. Row 2. Start with 'Dot' 'Blank'. then the second row from Mylar Drawing. Then continue with 'Dot' 'Blank' across row end. Continue in this manner thru Row 60. Program Complete.

INPUT Program No. 1
2 Sts. 2 Rows.
Row 1: 'Blank' 'Dot'
Row 2: 'Dot' 'Blank'

Follow the written Instructions in Magazine. After Row 465(483) Program Pat. 2 and PRESS Variation Key No. 5.(Upside Down Key)

Sounds like a lot of work - but - IT TOOK NO LONGER TO PUT THIS INTO THE COMPUTER THAN IT DID FOR OUR PERSON TO DRAW THE PATTERN ON A 910 MYLAR SHEET. This was due, we know, to the fact that most of the Pattern was alternate dot/blank.

No. 584 - Yarn: Bulky Venetia & Regular Venetia
SIZES: 10/12 (14/16)
Price: \$68.11 73.67
SHIPPING: 3.50 3.50

No. 585 - Yarn: Roma
SIZES: One Size (6 to 20)
Price: 30.00
Shipping: 3.00

No. 586 - Yarn Pearlite
SIZES: 6/8 (10/12) [14]
Price: \$67.40 70.00 72.50
Shipping: 3.50 4.00 4.00

No. 587 - Yarn: Amore
SIZES: 10/12 (14/16) [18/20]
Price: \$43.02 47.80 52.58
Shipping: 3.00 3.50 4.00

No. 588 - Yarn: Venetia & Mami Rex (Soft)
SIZES: 10/12 (14/16)
Price: \$87.70 90.48
Shipping: 5.00 5.00

No. 589 - Yarn: Venetia
SIZES: 8/10 (12/14) [16/18]
Price: \$36.14 37.53 38.92
Shipping: 3.50 3.50 4.00

No. 590 - Yarn: Venetia and Pappillon
SIZES: 6/8 (10/12) [14/16]
Price: \$80.96 83.74 86.52
Shipping: 4.50 4.50 5.00

No. 591 - Yarn Venetia
SIZES: 12/14 (16)
Price: \$36.14 41.70
Shipping: 4.00 4.00

(Appliques & Beads

No. 592 - Yarn: Angora, Glace, Mirage(Not Included)
SIZES: Small Med. Large
Price: \$86.45 91.95 97.45
Shipping: 5.00 5.00 5.00

No. 593 - Yarn: Venetia
SIZES: 2/3 (4/5) [6/7]
Price: \$30.58 33.36 36.14
Shipping: 3.50 3.50 3.50

No. 594 - Yarn: Venetia and Glace
SIZES: 6/8 (10/12) [14/16]
Price: \$54.75 56.14 57.53
Shipping: 4.00 4.00 4.00

No. 595 - Yarn: Nordic
SIZES: 8/10 (12/14)
Price: \$30.00 32.50
Shipping: 3.00 3.00

No. 596 - Yarn: Venetia
SIZES: 8/10 (12/14) [16]
Price: \$73.67 75.06 76.45
Shipping: 5.00 5.00 5.00

No. 597 - Yarn: Amore
SIZES: 8/10 (12/14) [16]
Price: \$40.63 43.02 45.41
Shipping: 3.00 3.00 3.00

No. 598 - Yarn: Bulky Venetia
SIZES: 36/38 (40/42) [44]
Price: \$47.26 50.04 52.82
Shipping: 4.00 4.00 4.50

No. 599 - Yarn: Glace and Thread
SIZE: Approx. 68" x 76"
Price: \$86.50
Shipping: 5.00

No. 600 - Yarn: Glace and Sewing Thread
SIZES: To Fit Single Bed.
Price: \$113.00
Shipping: 6.50

No. 601 - Yarn: Angora, Glace & Venetia
SIZES: To fit Size 6 to 16
Price: \$175.58 (Does not include price of tassel)
Shipping: 6.50

No. 602A- Yarn: Roma
 SIZES: 6/8 (10/12) [14/16]
 Price: \$42.50 43.75 45.00
 Shipping: 3.50 3.50 3.50

No. 603 -Yarn: Pebble, Angora, Bulky Venetia & Glace
 Sizes: 12/14 (16/18)
 Price: \$79.34 87.14
 Shipping: 5.00 5.00

No. 602B- Yarn: Roma
 SIZES: 2/4 (6/8)
 Price: \$22.50
 Shipping: 3.00

No. 604 - Yarn: Venetia
 SIZES: 14/16 (34/36) [38]
 Price: \$25.02 26.41 27.80
 Shipping: 3.00 3.00 3.00

essentials

Order from your local Dealer or direct from
KNITKING - 1128 Crenshaw Blvd.,
 Los Angeles, California 90019

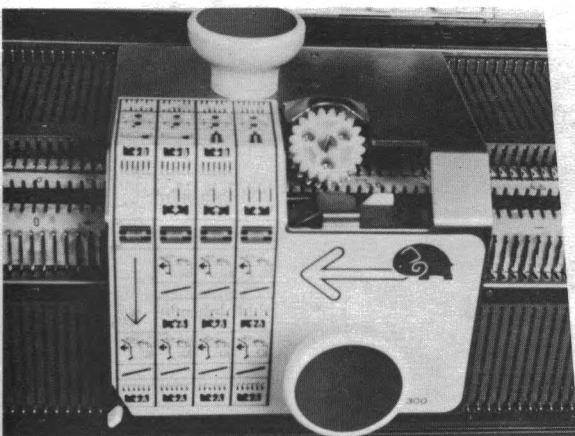

TRANSFER CARRIAGE

For fast and accurate transfer of stitches from Ribber to Knitter, the Automatic Transfer Carriage is **ESSENTIAL**.

Model 8300 is for Ribbers KR 900, KR 880, KR 850 and KR 830 and machine Models KH 830 through **COMPUKNIT III** (not including Bulky machines).

AUTOMATIC PUNCH

The **PM 10** Automatic Punch Card Puncher is essential for speedy punching of all your punch card designs. It's O.K. for all **KNITKING**, Brother, Studio, Singer and Toyota punch card machines.

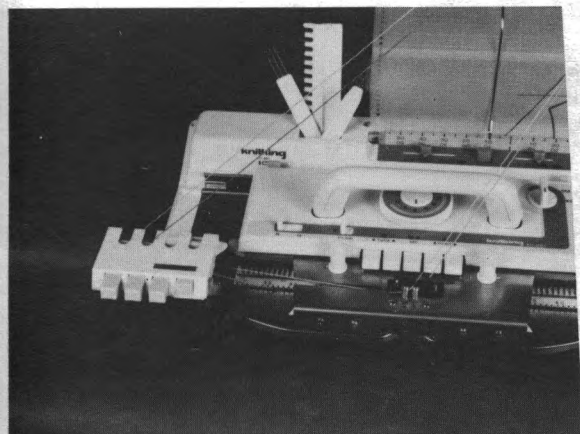
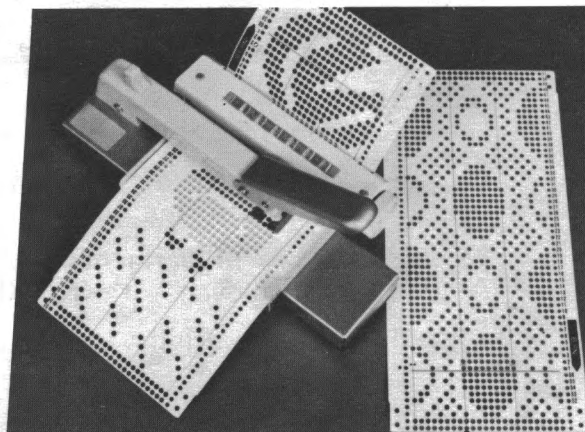

KHC 820-A COLOR CHANGER

The KHC 820-A Color Changer is essential for automatic changing of colors when knitting on **KNITKING** machine Models KH 820 through **COMPUKNIT III** (not including the KH 260 Bulky)

KRC 900 COLOR CHANGER

The KRC 900 Color Changer is essential for automatic color changing and the knitting of four color designs when using a Knitter and Ribber combination. It operates on Models KH 830 through **COMPUKNIT III** (including the KH 260 Bulky) with Ribbing Attachments.

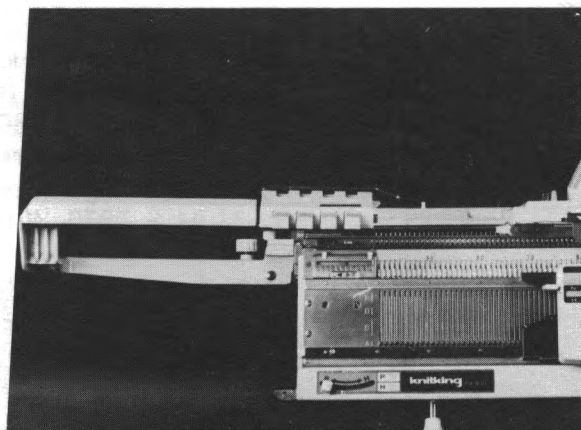

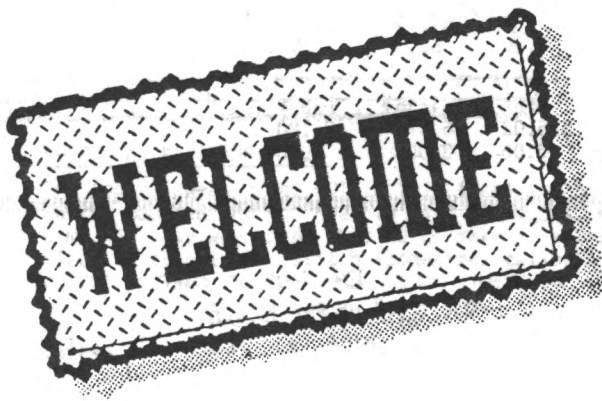

SEMINAR & OPEN HOUSE

knitking

1987

SEPTEMBER 14th through 19th

- * Join us ! Our open house runs from September 14th through 19th and will be held at **KNITKING**, 1128 Crenshaw Blvd., Los Angeles, Calif. 90019.
- * Come and meet our experts along with many acknowledged guest authorities. You'll get to see great new products too!
- * **ENJOY!** You'll love our daily Fashion Show and Contest! Daily winners will receive prizes and are eligible for the finals and a **GRAND PRIZE** at the close of the Seminar.
- * **WIN!** All types of garments are eligible, so start knitting now! (Sorry, knitting machine dealers and employees of **KNITKING** not eligible).
- * **IT'S FREE!** Just bring yourself and some friends and join us for prizes, events and free coffee and doughnuts.
- * Our regular seminar visitors will tell you ours are the best, so plan to be with us at **KNITKING** from September 14th through the 19th... We promise you a great time.
- * **YUKIKO MITSUMATA**, the foremost teacher from the factory in Japan will be with us again.. She has the answers to all of your questions on all of our machines.
- * Another wizard on the machines is Mary Louise Norman. Her classes are always filled and everybody that meets her becomes her friend.
- * You will see our new offices and garment design studio and meet the clever people who make the garments for **KNITKING MAGAZINE**.

- * It's a good idea to make your Hotel reservations well in advance and we recommend any the following; The closest and the lowest in price is the Wilshire Dunes.
Wilshire Dunes Motor Hotel - 4300 Wilshire Blvd., Los Angeles, CA 90010. Tel:213-938-3616
Ambassador Hotel - 3300 Wilshire Blvd., Los Angeles, CA 90010 Tel: 213-387-7011
Hilton - Downtown Los Angeles - 930 Wilshire Blvd., 90017 Tel: 213-629-4321
Hilton - Beverly Hills - 9876 Wilshire Blvd., 90010 Tel: 213-274-7777
Wilshire Hyatt House - 3515 Wilshire Blvd, Los Angeles, CA 90010 - Toll Free 800-228-9000
Century Plaza Hotel - Beverly Hills - Century City area - Avenue of the Stars, 90067
Tel: 213-277-2000

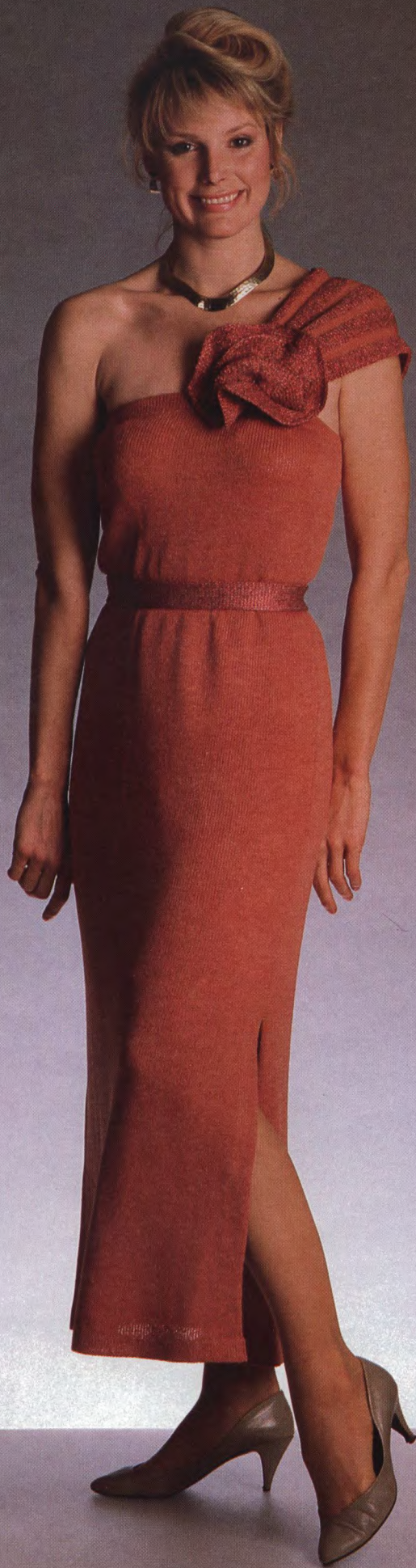

590 night magic

For your special enchanted evening, dare to be different and wear this eye catching off the shoulder evening Gown. It's easy to knit on any standard or electronic machine using our Venetia and Papillon yarn. Sizes 6 to 16.

597

pamper
yourself

with a super Leisure Suit. The balloon type pants are comfortable and warm, the Top has wide stripes of color. For easy care, knit it with Amore that takes to the washer and dryer.
Sizes 8 to 16.



595

outstanding

A Bulky Punch Card machine will surprise you with its interesting Fair Isle Designs and this one we think is one of the prettiest. A Pullover to wear with Skirt or Slacks. Knit it with our newest Nordic yarn.



585 triangles

form a special shaping for a colorful lace Blouse that will catch every eye. It drapes beautifully and is easy to knit on any standard machine with Lace Carriage. Knit it with our Roma yarn.



587 show off

A Fair Isle border Design lends distinction to a lovely Blouse. The fitting is easy and it's perfect to wear with Slacks or Skirt. Knit it with our Amore yarn in sizes 10 to 20.



604

handsome

Snappy, crisp Stripes are a different color on each side of this Pullover and the result will please any young man. Easy to knit sideways on the machine using Venetia yarn. We've made it in a boys size 14/16 and a young mans size 34/36 and 38.



598 great texture

A two-color Tuck stitch Pattern makes up into a handsome Pullover for a handsome Man. It's worn on the purl side and is knitted on the COMPUKNIT III machine. The bands are ribbed. Bulky Venetia is the yarn.

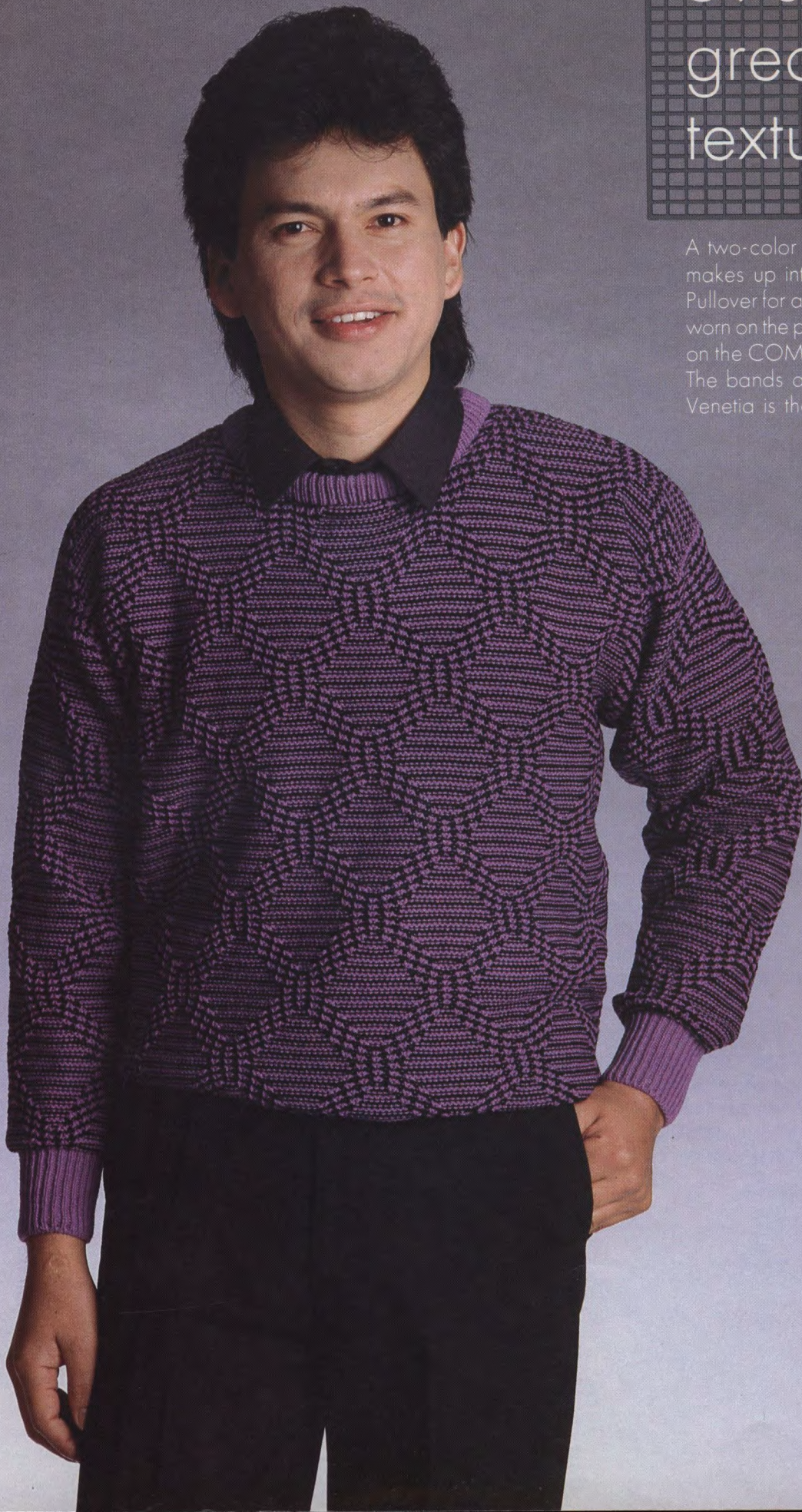

KNITKING Punch Card Programmed Bulky with KR 260 Ribbing Attachment

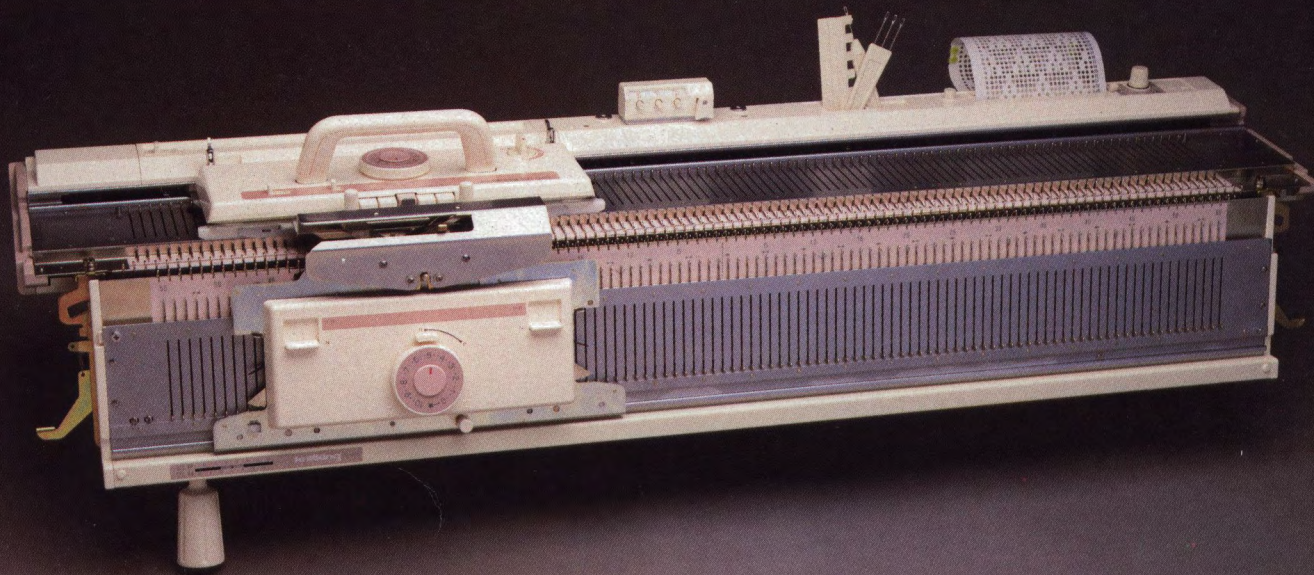

Add a Ribbing Attachment to your KH 260 KNITKING Bulky Knitter and substantially increase its versatility. The KR 260 Ribber allows you to knit all of the standard ribs 1x1, 2x2, 3x1, or any other combination of knit and purl you desire, plus tubular knitting. With 110 needles on the Ribber and 114 needles on the KH 260 Knitter, you have a total of 224 needles. You can knit fully ribbed dresses and sweaters with weights of yarn from fingering up to heavy bulky. You can knit Zig-Zag racking designs, Cable Stitch designs...Herringbone designs, Tuck Stitch Rib designs, Fishermans Rib, etc., etc...

A KR 260 Ribber comes complete with tools, cast on combs, weights, manual and one year limited warranty on parts, detailed instruction and service.

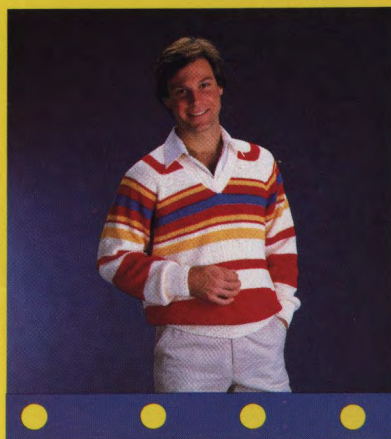

593 a little girls dream



Mice peek from all the pockets on this adorable three-piece ensemble. A Jumper, blouse and Socks . . . all to delight your favorite little girl. Knit it with Venetia is Sizes 2 to 7.

599 take center stage

A knitted Table Cover for all to admire. Different fruits and vegetables are single Motifs isolated in sectional strips with Lace strips between. Just what you need for special breakfast or lunch dining. Use Glace and sewing thread.



600

heirloom

status

Create an elegant guest bedroom beginning with an exquisite Bedspread. The Pattern is Thread Lace. Frilly Ruffles go around the edges. Add a matching king-size Pillow Sham to complete the picture. Use Glace and Sewing Thread.



FOR UNLIMITED VERSATILITY

The Sensational
COMPUKNIT III

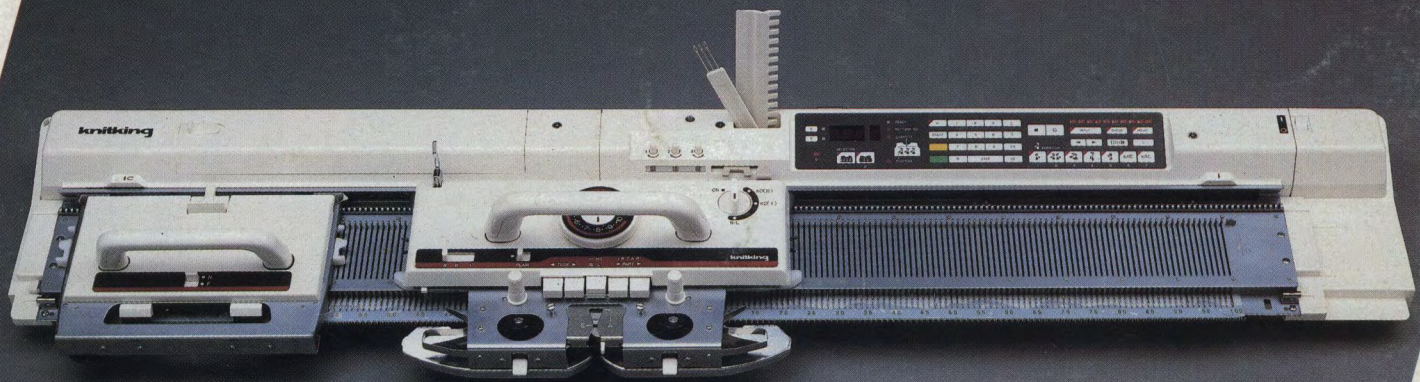

COMPUKNIT III with Lace Carriage and regular Knitting Carriage. Both carriages are standard with the purchase of a COMPUKNIT III. The Lace Carriage knits true Transfer Lace. It automatically knits beautiful yarn-over designs in any combination up to the full 200 needle width of the knitter. It also knits Fine Lace. The Computer permits isolation of Lace designs anywhere you wish in a garment.

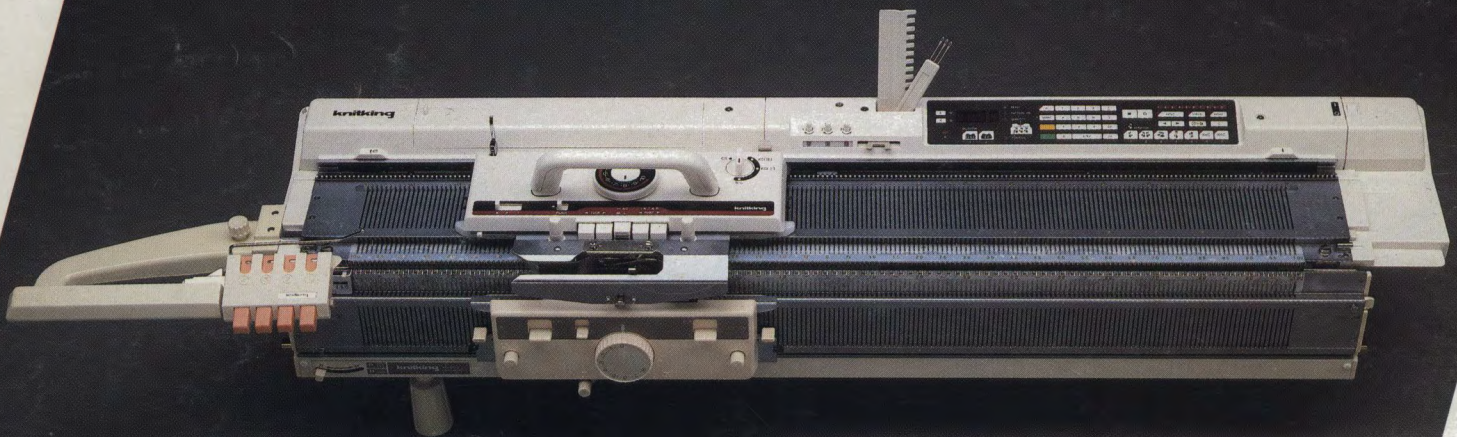

The COMPUKNIT III is illustrated with the KR 900 Ribbing Attachment and the KRC 830 Color Changer (both optional accessories). The Ribbing Attachment knits any combination of knit and purl ribs, racking designs, cable stitches, tubular knitting, etc. Add the KRC 830 Automatic Color Changer and you can knit up to four colors in one row in double knit jacquard. You can also introduce yarns of various textures into a garment. The KHC 820 Color Changer (not shown) operates on the basic machine for the knitting of multi-color designs in Stockinette Stitch.

Order from your local Dealer or direct from **KNITTING CORPORATION**, 1128 Crenshaw Blvd., Los Angeles, California 90019. Tel: 213-938-2077.