

englisch

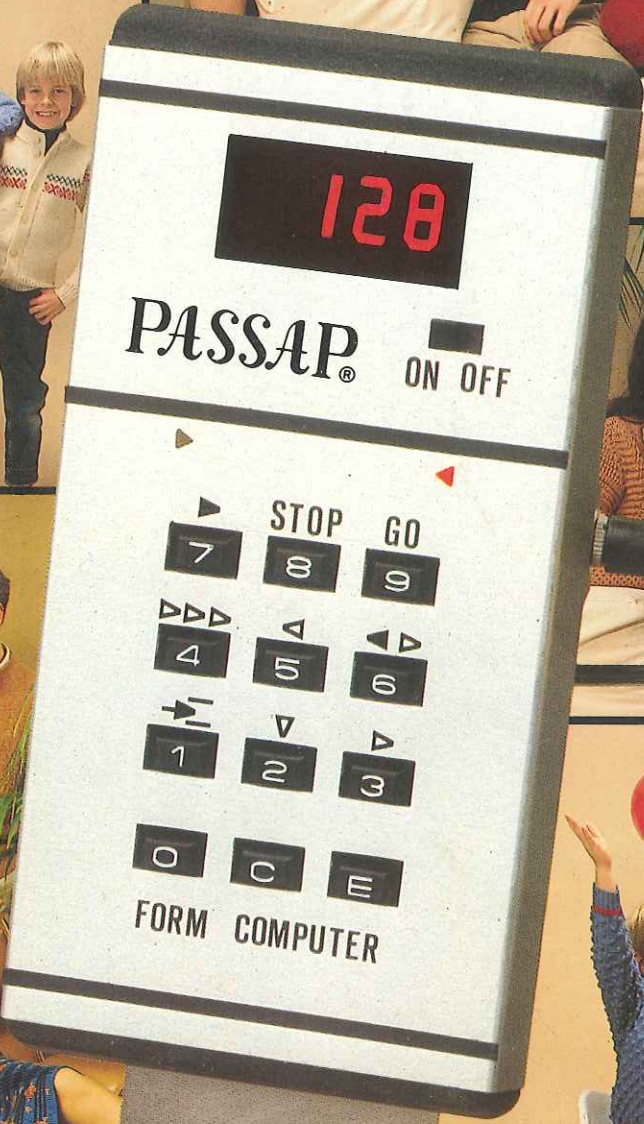

**FORM COMPUTER**

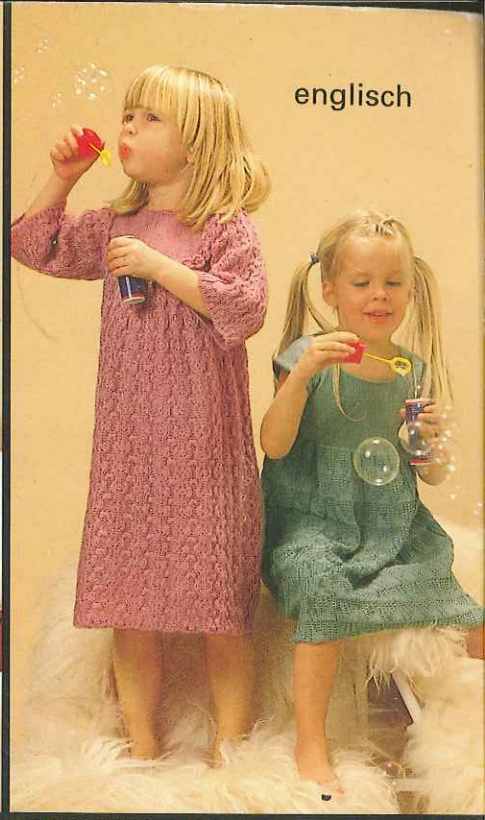

# PASSAP®

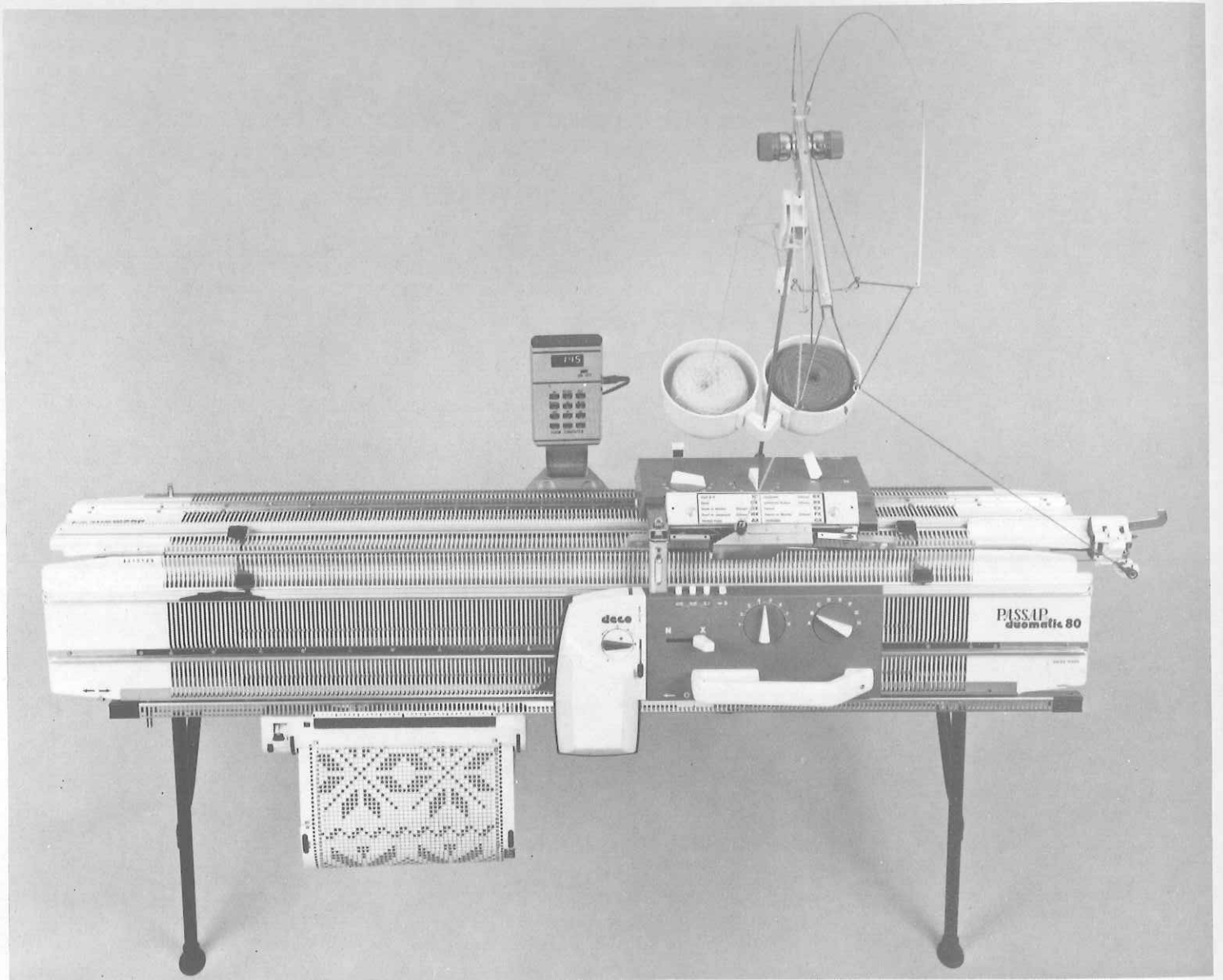

# Instruction Book

# FORM COMPUTER

---

- 2 Outline of the FORM COMPUTER
- 3 Fitting the FORM COMPUTER
- 6 The test square
- 7 Choosing the correct programme
- 8 Inserting individual measurements into the programme
- 10 Entering the programme
- 11 Checking the programme
- 12 Knitting with the computer
- 17 Illustrations of 42 garments
- 33 Practical tips
- 36 Various neckbands and polo neck collar
- 39 Programmes for 42 garments

# FORM COMPUTER

This is just an outline, for more detailed explanations see pages 14 to 16.

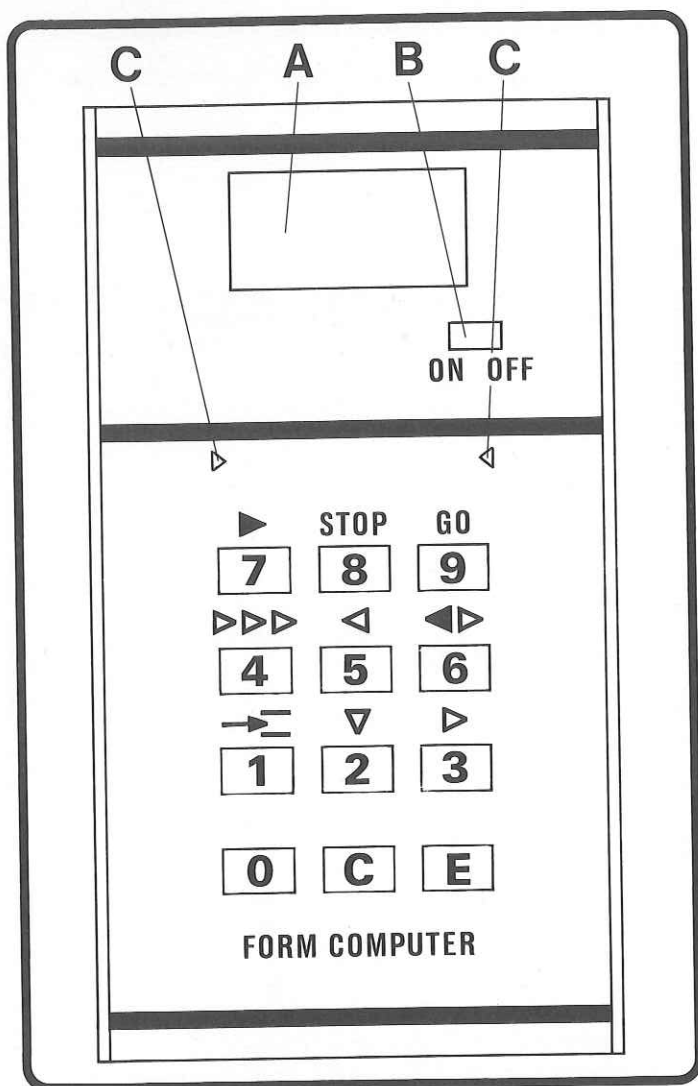

The figures 0–9 have two uses.

- A. As digits when entering the programme (see page 10).
- B. As functions while checking the knitting (see next column).

## A Display

## B ON/OFF switch

**C Lock position indicator.** Lights up left or right according to position of lock.

**Key 9 = GO.** Returns computer to working position after it has been in rest position.

**Key 8 = STOP.** Brings computer to rest position.

**Key 7 = ►** While the indication for "cast on" appears, the left position indicator can be lit up by pressing this Key if one wants to begin with the lock at left.

**Key 6 = ◀▶ mirroring.** Reverses settings (e.g. would re-set calculations for right front to those required for left front).

**Key 5 = ◀ Rolls back programme.** When pressed you can enter the number of rows by which you require the programme to be set back. Always press Key E afterwards.

**Key 4 = ►►► fast forward.** While "cast on" is displayed and after pressing Key 4 you can advance the programme by the number of rows required. Always press Key E afterwards.

**Key 3 = ► 1 row forward.** Advances the programme by 1 row each time it is pressed.

**Key 2 = ▼ knitted rows.** While this Key is pressed the number of rows of knitting already completed will be displayed.

**Key 1 = →= Inserting a figure.** After pressing this Key you can insert a figure during the programme check. Always press Key E afterwards.

**Key 0 = Zero.** This Key is used to clear any figure not required, during the programme check.

**Key C = Clear Key.** Clears incorrect figures which are to be replaced by corrected ones.

**Key E.** After pressing this Key the figure entered immediately previously will be put into store for the computer to use during its calculations.



# Fitting the FORM COMPUTER

## Fitting the supporting foot to the DUOMATIC 80, DUOMATIC S and DUOMATIC with COLOR

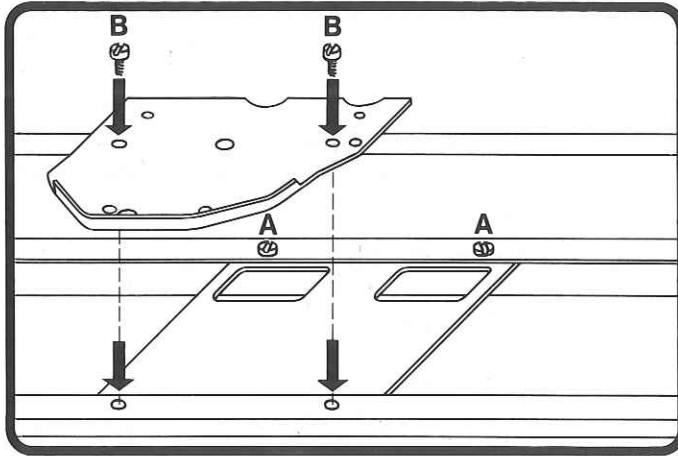

- Remove the locks and edge springs from the beds. Take the machine off the stand and place it upside down on a table.
- As per sketch, slide the connecting plate underneath the edges of the back bed so that the pegs fit into their respective holes.
- Using two of the four largest screws, screw the connecting plate to the inner edge (A).
- Using the two remaining largest screws, screw the support as per sketch to the outer edge and the connecting plate (B).

## Fitting the supporting foot to the ELECTRA 2000

(Ask your stockist about fitting the FORM COMPUTER to the ELECTRA M 75 B)

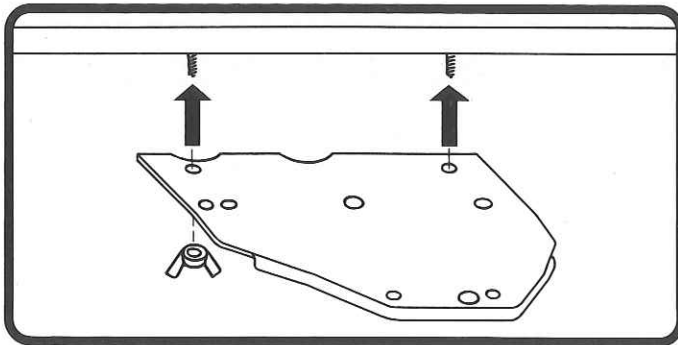

- Use two screws with hexagon heads from the ELECTRA 2000 accessory. Insert the heads of the screws into the holes located at left on the underside of the ELECTRA guide rail. Push the screws to about the middle of the bed.
- Fit the support over the two screws (with the holes as per sketch). Using the two wing nuts from the ELECTRA 2000 accessory, screw the support on, making sure the bent-away parts of the support are facing downwards.

## Fitting the mounting bracket

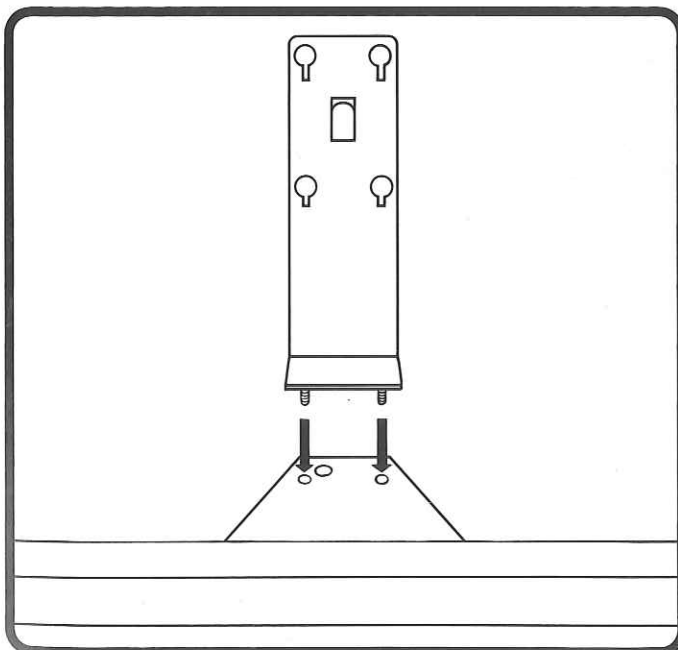

- Insert the two screws of the mounting bracket through the two holes of the supporting foot. Screw on the two knurled nuts from below.

# Fitting the FORM COMPUTER

## Fitting the driver to the back lock when knitting without the ELECTRA

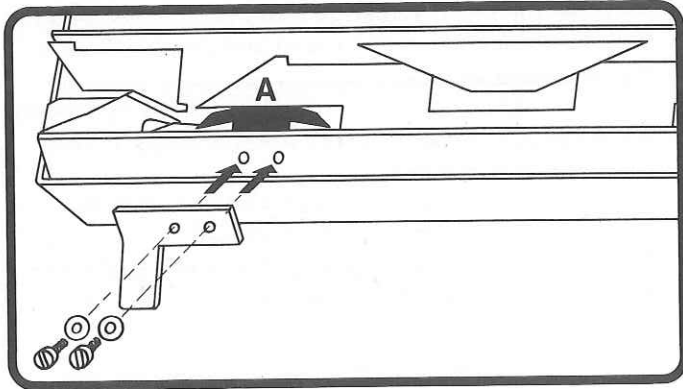

- Remove the back lock from the bed, and place it upside down on the table with the arrow key at right front.
- Loosen the left pusher retaining cam (A), keeping the two screws and washers.
- Screw on the smaller driver with the bent-away part and two holes as follows:

**For the DUOMATIC 80**, use the small silvery screws.

**For the DUOMATIC**, use the small dark-coloured screws.

**For the DUOMATIC S**, use the black, slim but longer screws, and instead of the pusher retaining cam (A) which the DUOMATIC S does not have, use the two wing nuts which must be held in place while the screws are screwed in.

**Note:** In this position, the bent-away part of the driver must face to the left as per sketch.

## Fitting the driver when using the ELECTRA 2000

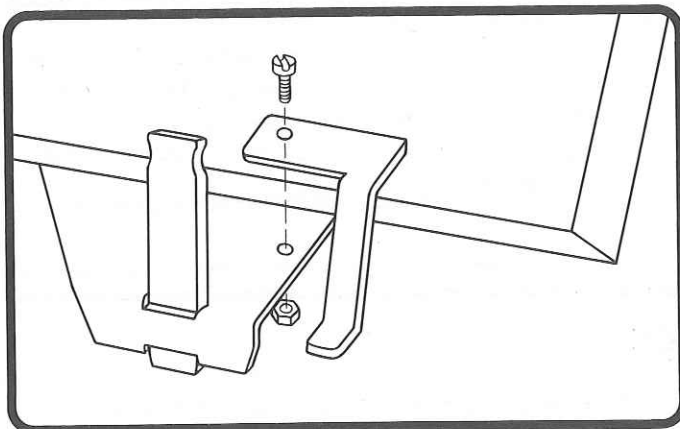

- Place the larger driver, which is bent in two places, from above on to the connecting plate of the lock and ELECTRA.
- Insert one of the largest of the four screws from above in the hole and fix it from underneath with a nut.

## Fitting the magnet holder to its driver

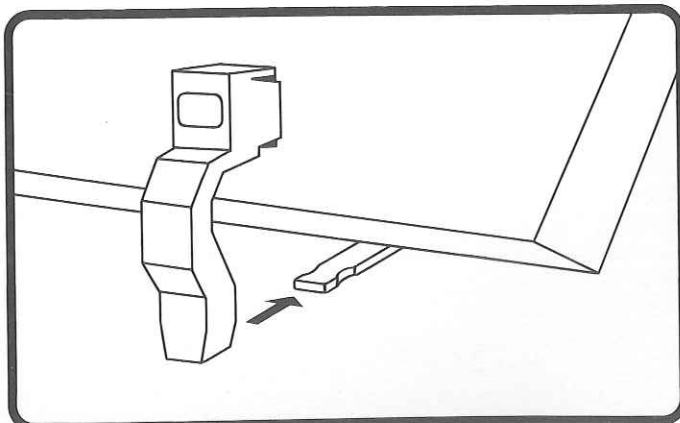

- Push the magnet holder on to the driver, as per sketch, until it snaps in.



# Fitting the FORM COMPUTER

## Connecting the FORM COMPUTER to the mounting bracket

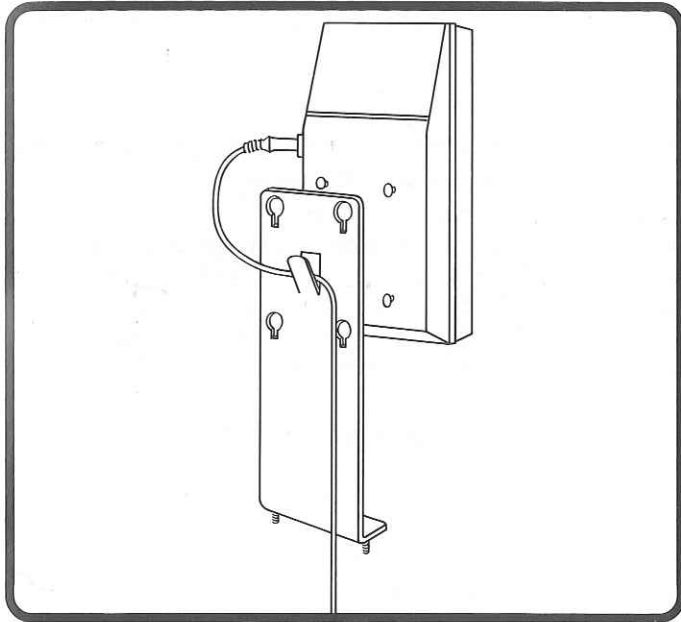

- Insert the four pegs on the back of the computer into the four keyhole-shaped openings of the mounting bracket, then press the computer down.
- Connect the adapter to the computer, and lay the wire into the hook on the back of the mounting bracket.

## Checking that the distance from the magnet to the FORM COMPUTER is correct

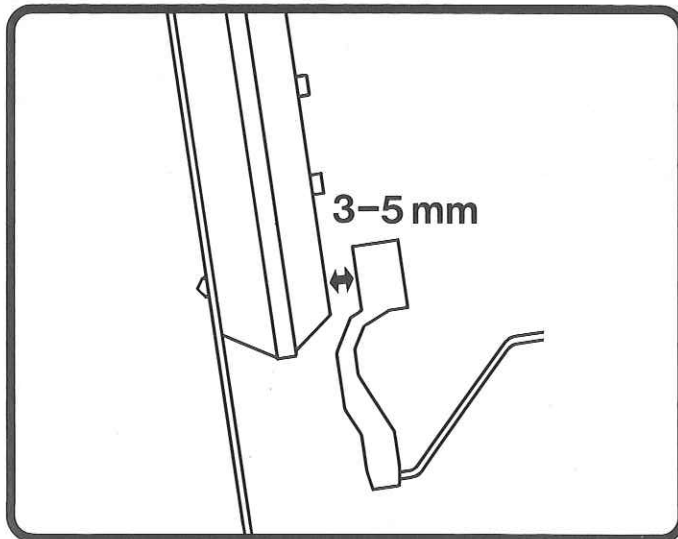

- The distance from the magnet to the lower edge of the FORM COMPUTER must be approximately 3 to 5 mm. An inaccurate distance may lead to errors. Should this be the case, slightly bend the mounting bracket of the FORM COMPUTER.

# The Test Square

Take advantage of what the FORM COMPUTER has to offer: choose the style of garment you prefer, then add the stitch pattern, the yarn and the colour you want.

You have chosen the yarn and the stitch pattern and are now ready to knit the test square. This is vital, for without it the computer cannot work out how many stitches have to be cast on and how many rows have to be knitted.

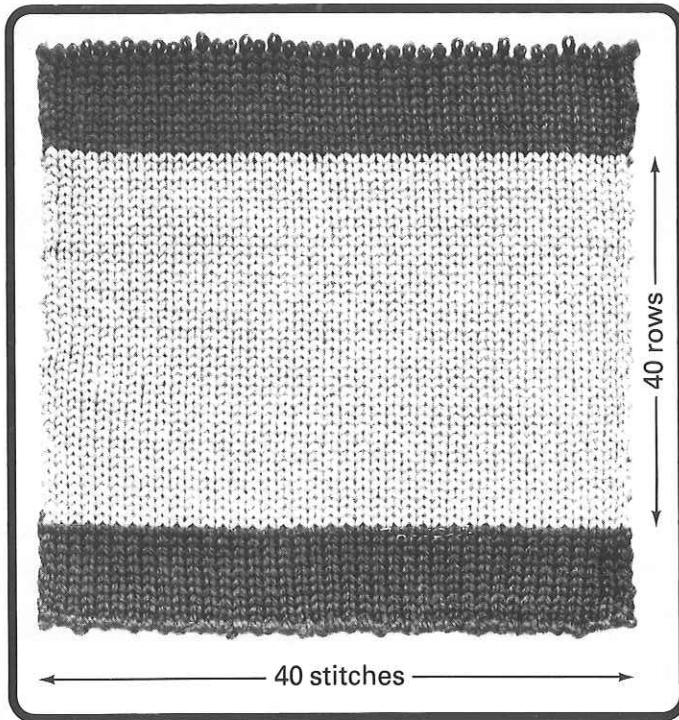

When you work with the FORM COMPUTER you need the measurements in millimetres from a test square 40 rows by 40 stitches.

**Note:** only the stitches on the front bed are counted. Where a stitch pattern has some needles in non-working position then these needles are counted, too. The test square must be worked over 40 needles as indicated on the needle scale.

**For counting rows always refer to the row counter.**

This also applies to double-bed knitting and in particular to tubular where only 20 rows can be seen on the actual piece of knitting whereas the row counter already indicates 40 rows.

**The test square** is always knitted in the yarn, the pattern, the stitch size and the yarn tension you will be using for your garment.

**Casting on and off always with contrast yarn.**

After casting on knit approximately 6 to 10 rows in contrast yarn before changing to your main yarn. Then, before you release your knitting, change back to contrast yarn. Knit 10 to 12 rows and release. Do not forget to press your test square if the finished garment is also to be pressed.

When knitting a particularly stretchy piece of material – or for patterns where 40 rows by 40 stitches result in very small test squares – it is recommended that you knit over a width of 80 needles and 80 rows, dividing the resulting measurements by 2.

**The test square for the border:** When you are knitting a garment with a border (band, welts, etc.) you also have to knit a test square for this so that the computer can work out the rows that have to be knitted. Here, the number of stitches is not important. All that is needed is the measurement, in millimetres, of 40 rows knitted in the stitch pattern selected for the border.



# Choosing the correct programme

The programme for each piece of knitting is contained in the corresponding row of figures given in the description for garments. **Each part (i.e. back, front, etc.) must be programmed separately.** When one part is finished the programme has to be cleared and the appropriate one for the next part entered.

**Start by taking your own measurements, or those of the person for whom you are going to knit.** Look at the chart below, and in the garment descriptions, to see what measurements you need and what individual measurements can be inserted in the programme.

All the measurements are body measurements and therefore the tape measure should fit closely.

**A = The bust/chest measurement** is taken across the widest part of the bust/chest.

**B = The hip size** is measured over the widest part of the hips.

**C = The total length** is taken at the back from the nape of the neck down to the required length of the sweater or dress.

**D = The total length of the skirt** is measured from the waist-band to where the hem should be.

**E = The total length of the sleeves** is measured along the extended arm from the shoulder point to the length required.

Note: this also applies to sleeves that are not set in the normal way, as for example kimono or raglan sleeves.

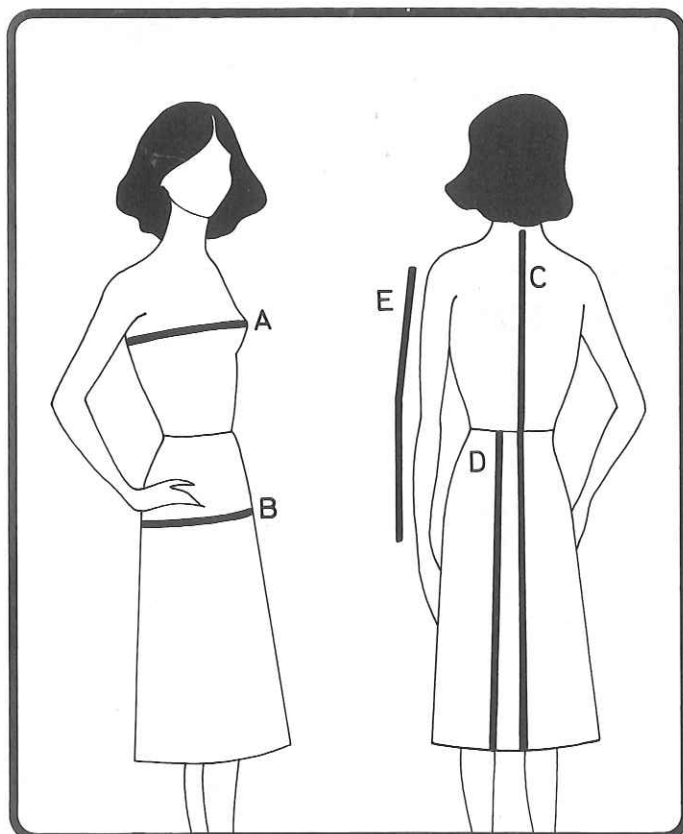

## Shop sizes

Ladies' sizes			Men's sizes		Children's sizes	
Size	Bust	Hips	Size	Chest	Height	Age
34	84 cm = 33¼ ins.	89 cm = 35¼ ins.	42	84 cm = 33¼ ins.	86 cm = 34 ins.	1
36	87 cm = 34¼ ins.	92 cm = 36¼ ins.	44	88 cm = 34¾ ins.	92 cm = 36¼ ins.	2
38	90 cm = 35½ ins.	95 cm = 37½ ins.	46	92 cm = 36¼ ins.	98 cm = 38¾ ins.	3
40	93 cm = 36¾ ins.	98 cm = 38¾ ins.	48	96 cm = 37¾ ins.	104 cm = 41 ins.	4
42	96 cm = 37¾ ins.	101 cm = 39¾ ins.	50	100 cm = 39½ ins.	110 cm = 43¼ ins.	5
44	99 cm = 39 ins.	104 cm = 41 ins.	52	104 cm = 41 ins.	116 cm = 45¾ ins.	6
46	102 cm = 40¼ ins.	107 cm = 42¼ ins.	54	108 cm = 42½ ins.	122 cm = 48 ins.	7
48	108 cm = 42½ ins.	113 cm = 44½ ins.	56	112 cm = 44 ins.	128 cm = 50¼ ins.	8
50	114 cm = 45 ins.	119 cm = 47 ins.			134 cm = 52¾ ins.	9
52	122 cm = 48¼ ins.	128 cm = 50½ ins.			140 cm = 55 ins.	10
54	128 cm = 50½ ins.	134 cm = 52¾ ins.			146 cm = 57½ ins.	11
					152 cm = 60 ins.	12
					158 cm = 62¼ ins.	13
					164 cm = 64½ ins.	14

# Inserting individual measurements into the programme

Now compare the measurements you have taken with the chart above which shows usual shop sizes. If your measurements do not correspond exactly with those in the chart choose the **next smaller size** and when you enter the programme insert your own measurements in the places provided for this purpose. The computer will now calculate the garment to your exact measurements, ensuring a perfect fit.

## Front of a lady's sweater

34	36	40	44
80	80	80	80
148	148	148	148
132	138	146	154
84	87	93	99
84	87	93	99
195	195	195	195
7	7	7	7
7	7	7	7
38	38	38	38
132	138	146	154
84	87	93	99
34	34	34	34
62	62	63	64
235	236	236	236
7	7	7	7
3	3	3	3
169	169	169	169
153	153	178	178
178	188	188	188
146	129	129	129
7	146	146	146
28	7	7	7
191	27	29	31
146	191	191	191
3	147	148	150
67	3	3	3
191	67	67	67
146	191	191	191
42	146	146	146
0	42	45	47
	0	0	0

mm 40 R  
mm 40 sts

mm 40 R  
Border

[ Bust  
Shop size  
Your bust size in cm

[ Total length  
Shop size  
Your total length in cm



## Test square

In each programme the 3rd and 4th line are left free for entering the measurements of the test square as follows:

**mm 40 R: Measurement in millimetres for 40 rows of your knitting.**

**mm 40 sts: Measurement in millimetres for 40 stitches of your knitting (or the measurement which results when knitting over a width of 40 needles on the front bed).**

**mm 40 R Border: The place where the measurement in millimetres for 40 rows for the border has to be inserted is specially marked in each programme.**

## Individual measurements

The measurements are always taken in centimetres. The places where individual measurements can be entered are specially indicated in each programme.

The measurement corresponding to the "shop size" chosen by you can be seen from the line immediately above the corresponding empty line and is expressed in centimetres.

**If you do not wish to alter the "shop size" measurements they must still be repeated in the empty line.**

**Important: You must always enter a figure here.** If you skip this position when entering a programme the computer cannot function correctly.



# Inserting individual measurements into the programme

When inserting individual measurements the following must be remembered:

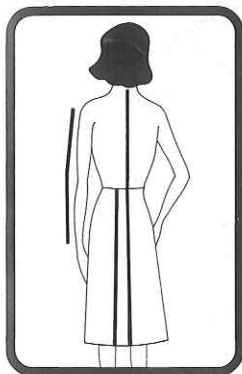

**Measurements related to the length** such as overall length of dresses, sweaters, skirts and sleeves (i.e. measurements referring to rows) **can be increased or decreased.**

Do not forget to adapt the figures of both front and back if you do.

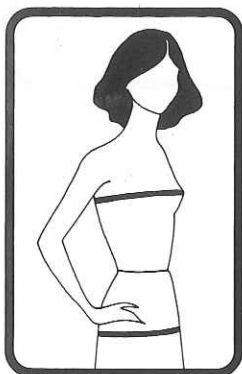

**Measurements across** (relating to the width) such as bust, chest, hips and sleeve width (i.e. measurements referring to stitches) **can only be enlarged.**

If you make the measurements referring to width smaller by mistake the computer will display the **message ERR 3** instead of CAST ON. In such a case press Key C, followed by Key E. You can now check the programme and amend it as explained on page 11.

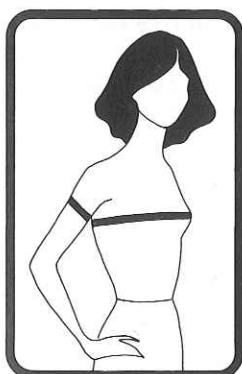

**Note:** If you add to the bust/chest size you will have to increase the upper width of the sleeves by exactly half the centimetres you have added to the bust/chest. If you do not increase the bust/chest measurement do not increase the upper sleeve width either, or the sleeve will not fit into the armhole.

# Entering the programme

Before you connect your transformer check that the voltage corresponds to the one of your mains, and make sure power unit ON/OFF switch is OFF before you connect to mains.

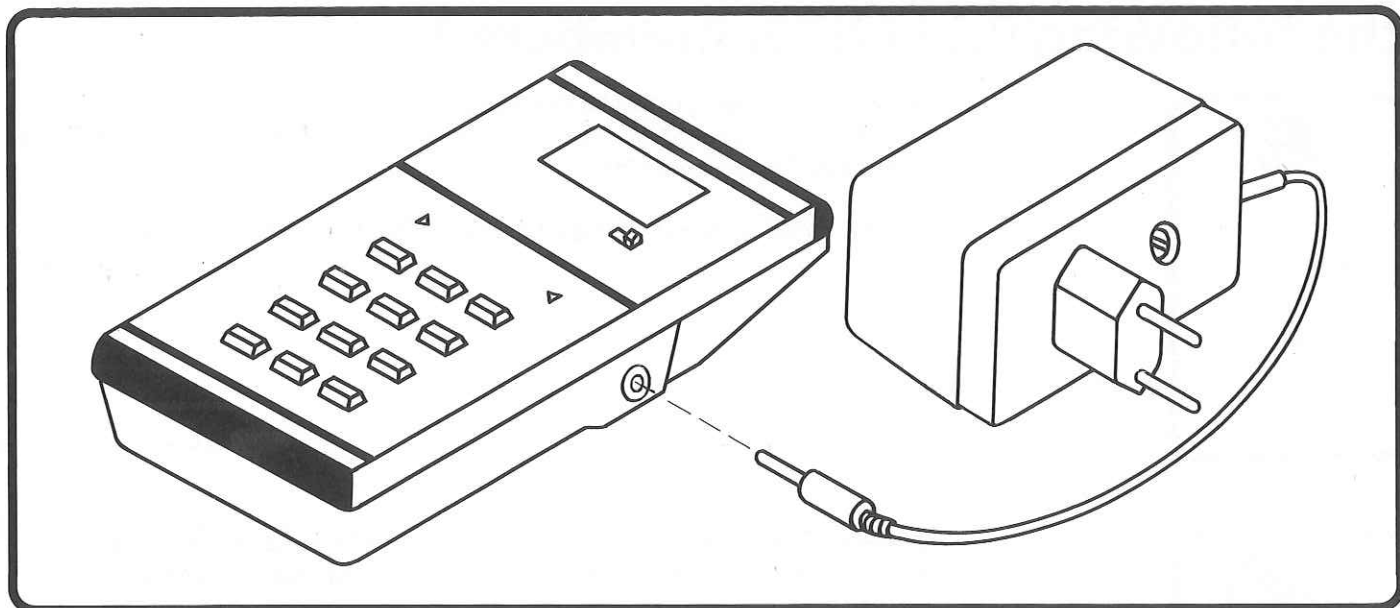

## Switching ON/OFF switch to ON

You can take the computer out of its support and hold it in your hand or place it on the table.

**Note:** When entering the programme, the computer has to be already plugged into the same socket as it will be for knitting. Do not disconnect it between entering the programme and knitting.

When the computer is disconnected from the power supply, or if the current is interrupted in some way, or if the ON/OFF switch is switched OFF, the programme is automatically erased, and you have to re-enter it.

## Enter the two or three digit number which you find on the first line of your programme.

In our example on page 8 this number is 80 (the number on black background indicates the "shop size" to which the programme refers and is never entered).

## The number will appear in the red light display.

## Press Key E when the correct figure appears in the light display.

If a wrong number is displayed because you have entered an incorrect figure, **press Key C to clear the error**. When you get the message ERR alternating with the figure 1 it means you have attempted to enter a figure the computer will not accept. You can clear this also by pressing Key C. Continue in this way, remembering to press Key E after each line, for only then will the computer store a figure with which to calculate later.

**The zero on the last line must also be entered**, followed once more by E. Now the first figure of the row of figures will automatically be displayed once more.



# Checking the programme

---

- **Check that the figure in the display corresponds to the first line of your programme.**
- **Press Key E and the next figure of your programme will be displayed.** Compare it with your written programme and continue to check in this way until the whole programme has been run through and you get the acoustic signal.

## What to do when you discover errors on checking the programme

### **1. You have entered a wrong figure:**

Press Key C to clear the figure, enter the correct one, then press Key E so that the computer will store it. Continue checking.

### **2. You have forgotten to enter a figure:**

Press Key 1 with the symbol for "inserting a figure". Enter the figure you have forgotten and then press Key E. Continue checking.

Should you have forgotten more than one figure, proceed in the same way, i.e. before each figure press Key 1, after each figure press Key E.

### **3. You have entered one figure too many:**

Press Key O to clear this figure.

---

### **Correcting the programme while you knit**

If you have the impression that the computer is giving you information which cannot be right, or if it suddenly does not display anything, you can check the programme again even during your knitting.

- Press Key E.

The first figure of the programme is displayed. By repeatedly pressing Key E you can run through the whole programme and correct it as described above for the first check.

# Knitting with the computer

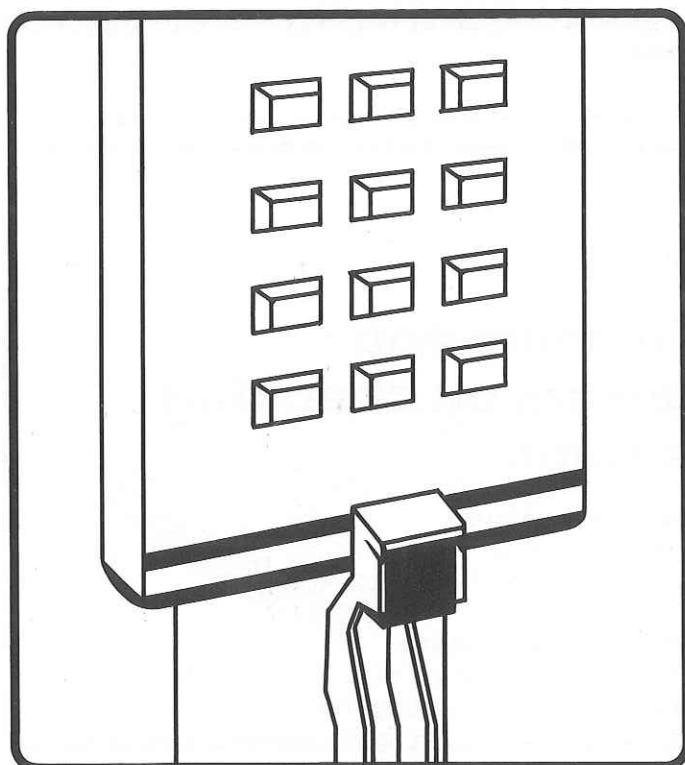

**When knitting with the computer make sure that each time you knit a row the magnet located on the back lock passes in front of the computer, otherwise it will not register this row.**

After checking the programme you will hear an acoustic signal and your first knitting instruction will appear in the display.

**The acoustic signal always sounds when you have to do something other than straight knitting.**

The computer can give you the following knitting instructions:

## Figures with a PLUS or MINUS sign always denote stitches

Displayed indications for stitches always refer to the front bed needles only, i.e. in double bed knitting the stitches on the back bed have to be correspondingly increased or decreased as for the stitches of the front bed. If not all needles are knitting any empty needles in between have to be counted as well.



**+ (plus) at the beginning of the work means casting on**

The number of stitches (i.e. the width of knitting on the front needle bed) which have to be cast on, appears alternately with the figure 1.

(Example: + 128 means: cast on over a width of 128 needles on the front bed)

**Should a figure that is higher than 179 appear in this place,** it means you cannot achieve the correct width, as required for this garment, with your test square. To achieve a wider test square, either increase the stitch size, choose a different pattern or a different yarn.

# Knitting with the computer

---

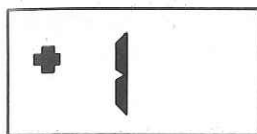

**+ (plus) during knitting means increasing stitches** i. e. always on the side of the knitting where the position indicator lights up and where the lock is.

(Example: + 1 means increase 1 stitch)

If the increases have to be made on the opposite side of the lock, this will be pointed out specially in the garment descriptions.

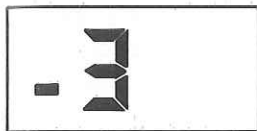

**- (minus) means decreasing stitches** on side of the knitting where the position indicator lights up and where the lock is.

(Example: - 3 means decrease 3 stitches)

---

## Figures without a PLUS or MINUS sign always refer to rows which still have to be knitted

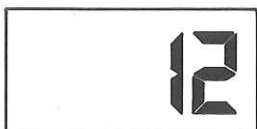

The computer counts backwards the rows that still have to be knitted before the next acoustic signal calling your attention to the next knitting instruction.

(Example: 12 means you still have 12 rows to knit before the computer gives you the next instructions)

---

## Flashing figures indicate knitting instructions

These flashing figures which sometimes appear on their own, sometimes alternating with previously mentioned figures, indicate a knitting process which will always be found in the description to the garment.

Some of these figures always have the same, fixed meaning:

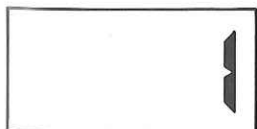

**1 = Cast on.** This figure flashes alternately with the figure denoting the number of stitches to be cast on. (This type of cast on is indicated in the garment description.)

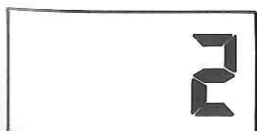

**2 = Transition from border (welts, bands, etc.) to main knitting.** Whether any stitches have to be transferred and how the lock setting has to be altered here, is indicated in the corresponding garment description.



# Knitting with the computer

---

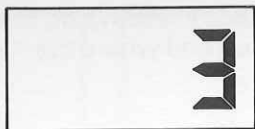

**3 = Dividing the work.** The piece of knitting is always divided exactly at the centre by placing the stitches of the left half on to deckercombs or, depending on the stitch pattern, by putting the corresponding needles out of working position with the aid of the pushers. The right half is always worked first.

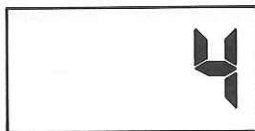

**4 = The first half of the neck opening has been knitted, the second half has still to be knitted.**

When the figure 4 appears in the display, the computer is automatically in rest position indicated by short, repetitive acoustic signals. You can now unhurriedly put the stitches of the second half back on the needles of the machine, set the lock correctly, without fear that the computer might mistakenly continue to count.

**To continue knitting, press Key GO**



**5 = The part is finished.** Cast off the remaining stitches or, depending on the instructions, finish with contrast yarn. When the message 5 appears, the computer is automatically in rest position.

---

## Auxiliary Keys used during knitting

GO

9

**If the same part is to be repeated, press Key GO,** and the computer will again display the beginning of the knitting.

GO

9

**If the same part is to be repeated with reversed shapings,** (e.g. the front part of a jacket), press Key GO, then Key 6 with the symbol for "mirroring".



6

# Knitting with the computer

---



2

**STOP**

8



5



3

## **Key 2 = Knitted rows**

For as long as you press this key the display will show the number of rows that have been knitted so far.

## **Key 8 STOP = Computer in rest position**

Always press this key when there is any possibility of the lock passing in front of the computer and working it when you do not wish to do so, e. g. when rows have to be undone. The rest position is denoted by short, repetitive signals.

## **To continue knitting press Key GO**

## **Key 5 = Undoing knitted rows**

If you have to undo some rows press this key when you have finished, enter the number of rows you have unraveled and then press Key E. The computer now moves back in the programme by as many rows as you have entered.

If the word ERR is displayed, alternating with the figure 2 you have entered more rows than you have actually knitted so far. Press Key C and enter the correct number of rows.

Remember, if you pressed Key STOP before undoing the rows you now have to press Key GO before Key 5.

## **Key 3 = 1 row forward**

If you press this key the programme advances by one row, just as if you had actually knitted one row. You can use Key 3 e. g. to get to the correct place in the programme if you have forgotten to press Key GO.

---

## Programming a new part

Before a new programme is entered the old one has to be cleared first, by switching off the computer, i.e. switching ON/OFF switch to OFF.

Switch ON/OFF switch to ON again and enter programme as described above.

### **ERR 1**

Means you have entered a figure the computer cannot accept. Press Key C and enter the correct figure.

### **ERR 2**

Means you have first pressed Key 5 = rolling back programme for unravelling rows, and then entered a figure which is higher than the rows you have already knitted. Press Key C and enter the correct figure.

### **ERR 3**

This indication is displayed instead of the message "cast on", and means you have reduced a measurement which can only be increased. Press Key C and then Key E. The first figure of the programme now appears.

Now check the programme once more and replace the wrong figure with the correct one as described on page 11.

# Knitting with the computer

---

## Interruption while knitting

Should you not be able to finish a piece of knitting the same day, you can leave the computer switched on overnight. If you want to switch it off, however, first check how many rows you have already knitted by pressing **Key 2 = knitted rows**. Make a note of it, and only then switch to OFF. To continue knitting, you have to re-enter the programme as already described.

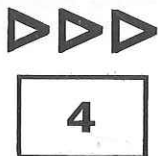

If after checking, the symbol for casting on appears, press **Key 4 ▶▶▶ = fast forward**, enter the row number where you interrupted your knitting, and which is also shown on your row counter. Press Key E and the computer will move forward to the place in the programme where you interrupted.

**Note: In order that you may always find the place you are looking for in the programme, the row counter on your machine must always be set to zero at the beginning of each piece of knitting.**

## Choosing your garment

---

On the following pages you will find the illustrations to the 42 garments that can be knitted with the programmes in this Instruction Book. Choose the pattern you like. As far as colours, stitch patterns and yarns are concerned, the illustrated garments are just some ideas. **You can of course knit each garment in this book with a different stitch pattern.** In addition to the stitch patterns proposed in this book you will find a selection of another 200 stitch patterns in our Stitch Pattern Book.

### **And why not use the same programme more than once?**

The six sweaters illustrated on the page opposite have all been knitted with the same programme no. 8 for a classic sweater with V-neck, and yet look completely different.

Let your imagination run free now that the FORM COMPUTER has freed you from all those tedious calculations.



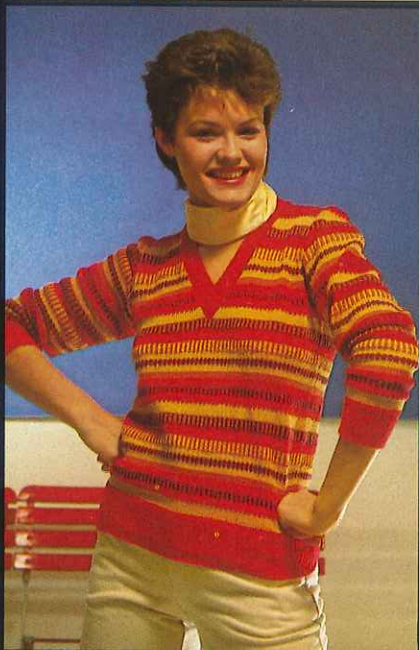
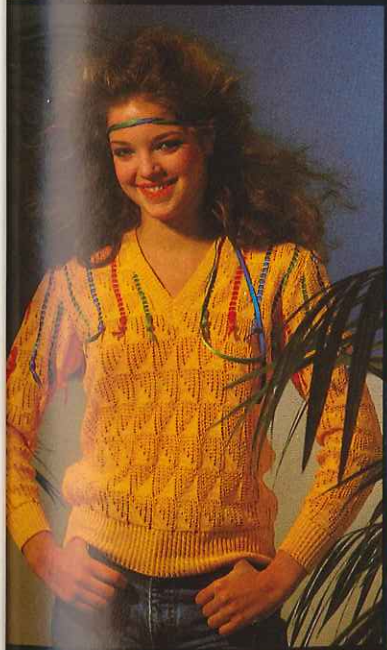



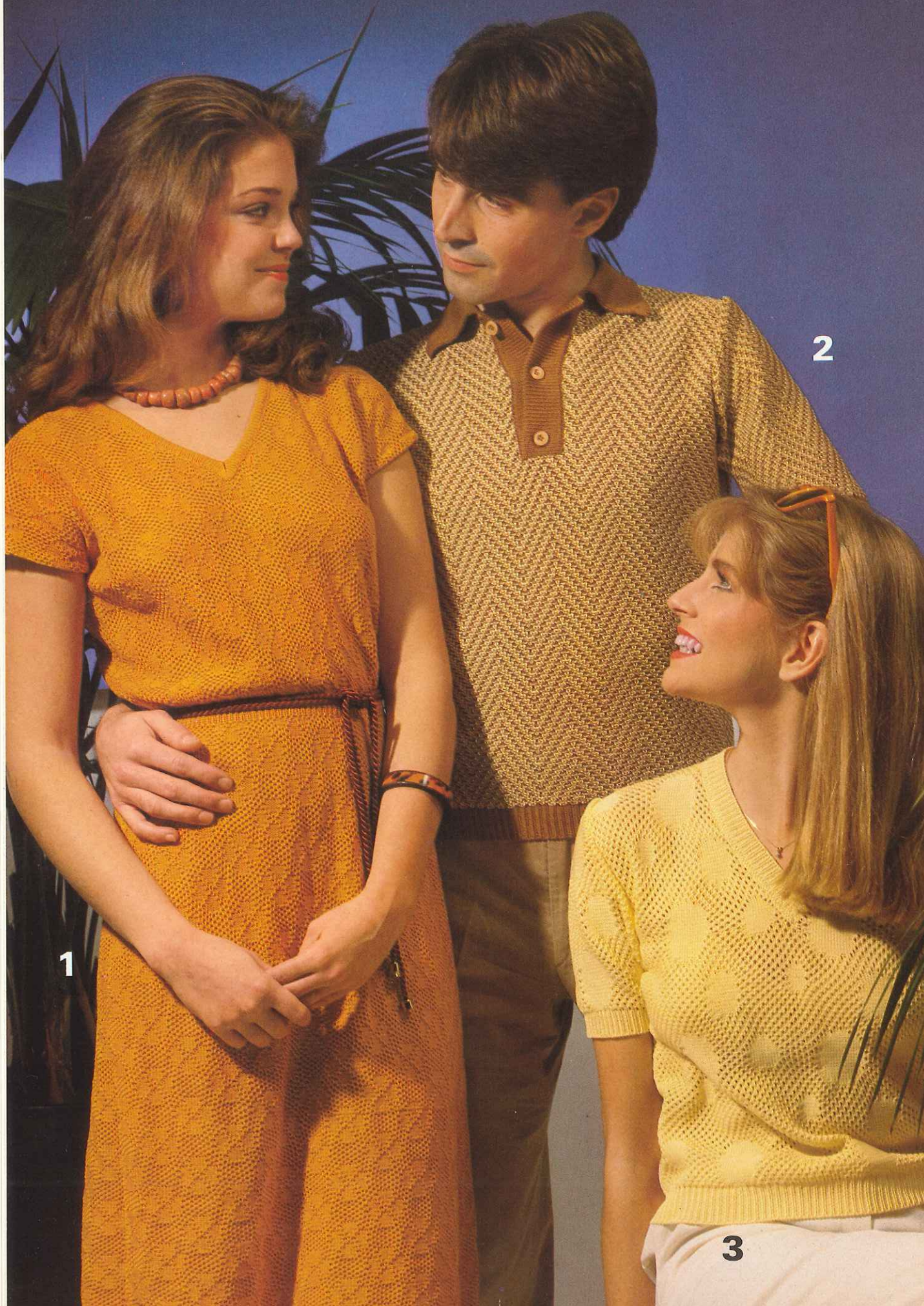

1

2

3





4

5

6



7

8

9





10



12



11

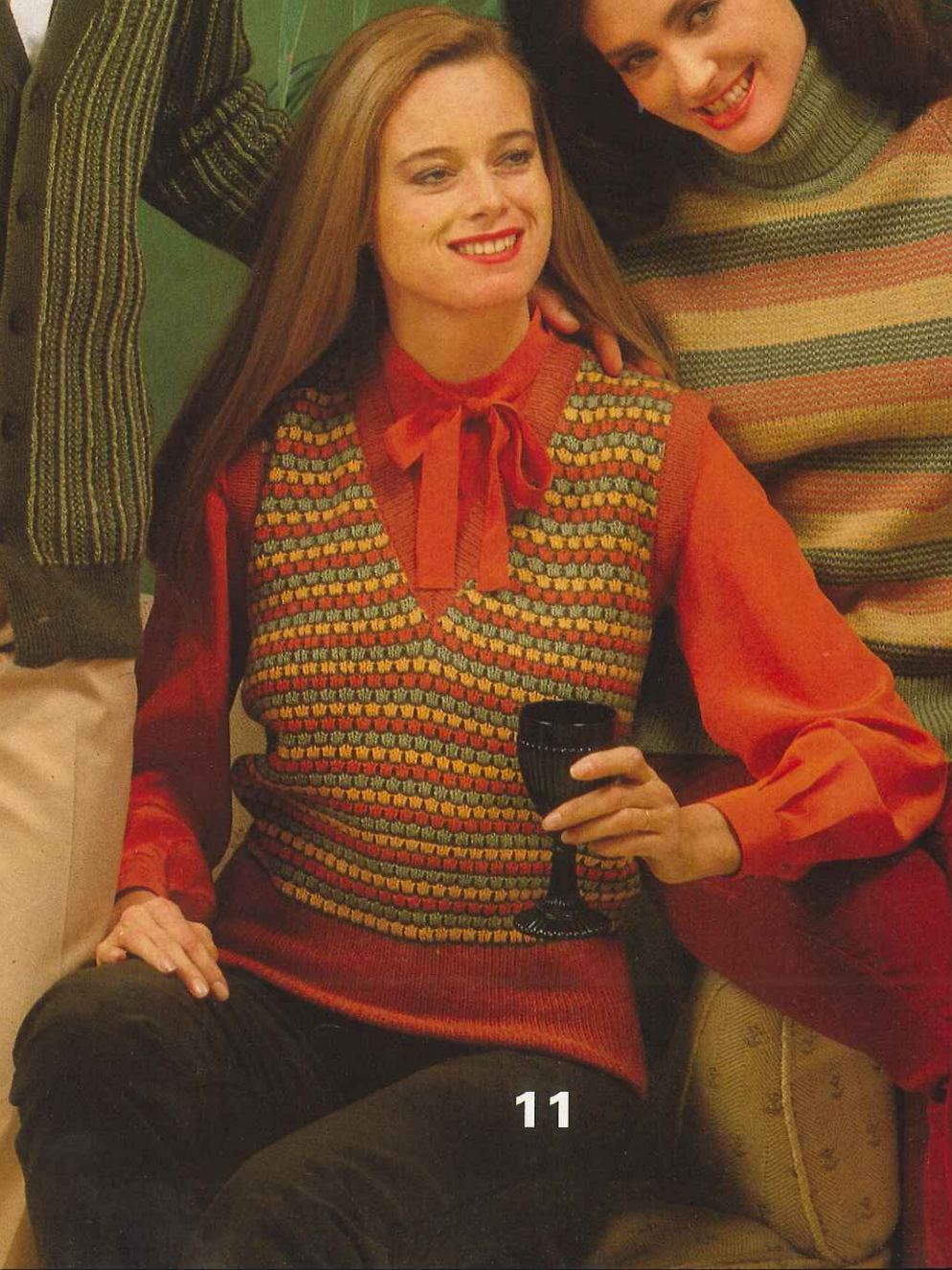



14

13







15

16



17



24

18



20



19

21

22







24

25

23



25



26

27



28



27





29



30



31



32



33



34





35



36



38



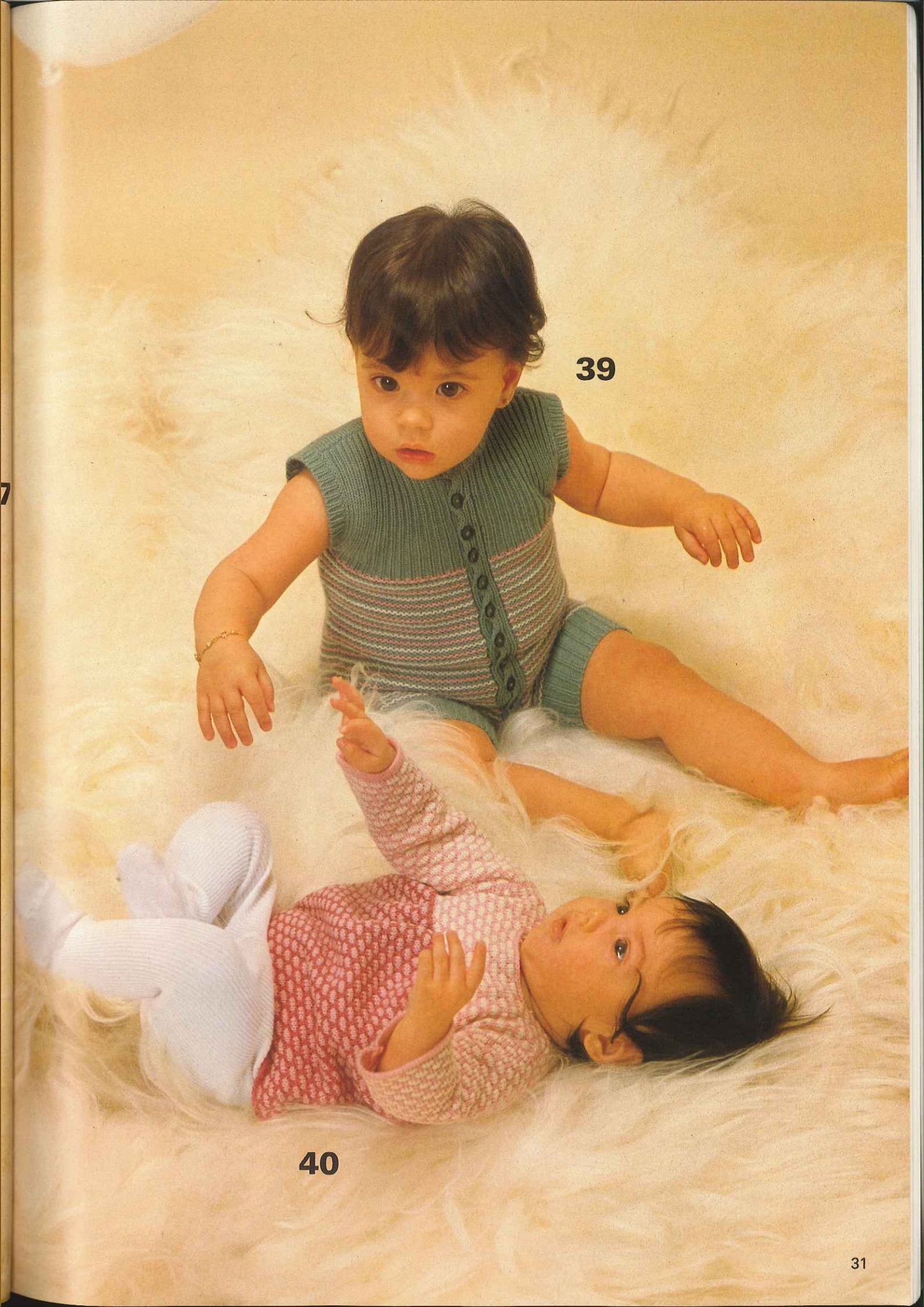

39

40





41



42



# Practical tips

Under the heading "**Flashing figures**" you will find in the following descriptions short knitting instructions. As they always refer to the same procedures they are kept short giving just the key-words. The main ones are described in detail in the following to enable you to refer back to them whenever necessary.

## Flashing figure 1: Cast on with contrast yarn

Contrast yarn is very often used to cast on if the cast on edge is sewn to another part, as in the case of a hem or a border, a yoke or some other piece of knitting.

As a contrast yarn, it is advisable to use a remainder of some yarn which has about the same thickness as the main yarn that you are going to use for your knitting, but it should be of a contrasting colour to make the stitches stand out.

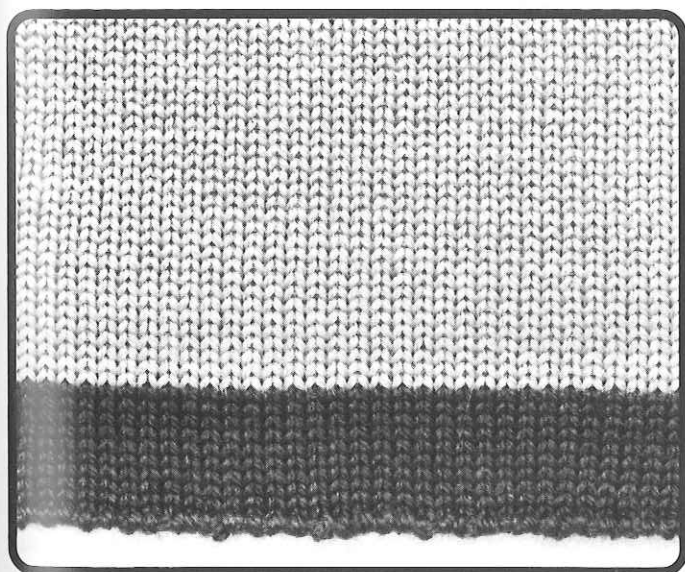

- **Enter the programme**, as described on page 10.
- **Press Key STOP** when flashing figure 1 for casting on appears.
- **With contrast yarn cast on over the indicated number of needles.**  
The type of cast on depends on the pattern which follows. You will find the instructions in the garment description. When casting on with contrast yarn, always use the simplest cast on as it will be unravelled later on, i.e. for single-bed knitting make a simple cast on without pushers, for double-bed knitting cast on with racking.
- **Knit 10 to 12 rows with contrast yarn.**  
Should you notice that you have forgotten to press Key STOP while you were knitting with contrast yarn, first press Key 2 ▽ = knitted rows to see how many rows you have knitted. Then press Key 5 ◀ = unravelling rows. Enter the number of the already knitted rows, and then press Key E. Your programme now goes back to the beginning with flashing figure 1 appearing for cast on.
- **Bring main yarn into the lock.**
- **Set row counter to zero.**
- **Press Key GO** and knit according to the indications given by the FORM COMPUTER.  
Should you have forgotten to press Key GO, check on your row counter how many rows you have already knitted, press Key GO and then as many times Key 3 ▶ = 1 row forward, as the number of rows you have knitted.



# Practical tips

## Flashing figure 5: A few rows with contrast yarn, release

A piece of knitting is finished in contrast yarn, if the piece has to be attached somewhere stitch by stitch using backstitch, e.g. when attaching a neckband.

- **Since the computer is in Rest Position when figures 4 or 5 flash,** you can bring the contrast yarn into the lock and knit 10 to 12 rows.
- **To release the stitches, move the empty lock twice across the needles.**

## Unravelling the contrast yarn

Before unravelling the contrast yarn, the piece of knitting must be pressed. In the case of a stitch pattern that must not be pressed, press only the rows knitted in contrast yarn. This will prevent the stitches from running while you sew.

## Sewing when knitting with contrast yarn

If you have knitted with contrast yarn, make sure that when you are sewing you catch every loose stitch. To be sure that no stitch runs while you sew, only unravel the contrast yarn to the last or last but one row before the main yarn, and unravel the rows while you are sewing.

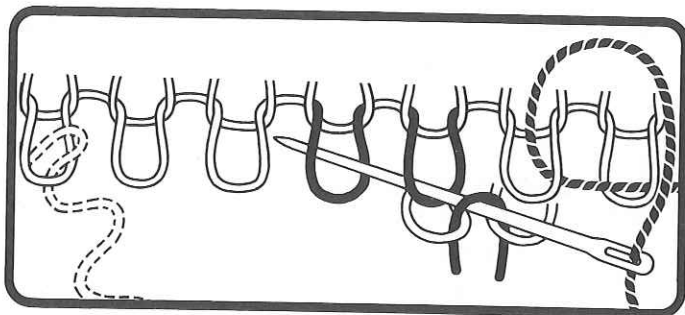

### Making a hem

Stitch by stitch sew open row of stitches, always picking up two stitches at a time and unravelling the contrast yarn stitch by stitch.

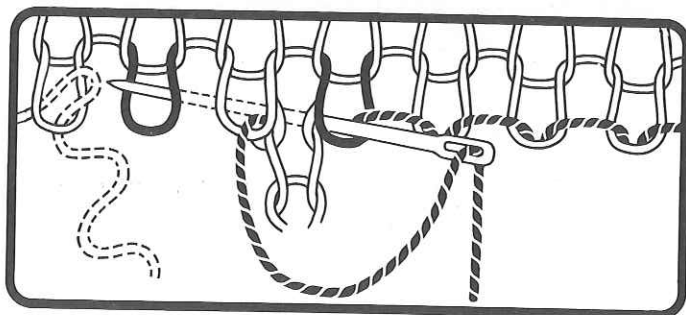

### Back stitching, stitch by stitch

Enter into the open stitch at right of the stitch sewn last and emerge from the open stitch at left of it, unravelling contrast yarn stitch by stitch.

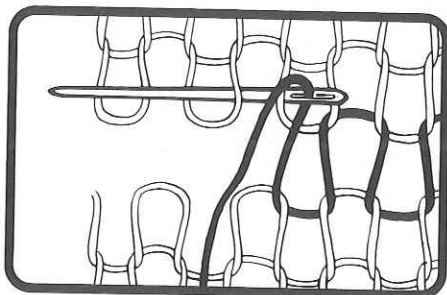

### The graft stitch

With right side of the knitting facing you, form the missing row of stitches.



# Practical tips

## Flashing figure 3: Divide work, continue to knit at right

This indication usually appears at the neck opening. **It means that the knitting must be divided exactly in the middle.** To divide the work there are various methods, depending on the stitch pattern and the material:

### Dividing the work with pushers

This method can be used only for stocking stitch or fairisle with lock setting BX or HX.

- **When knitting in stocking stitch, bring for each needle of the right half the corresponding pusher into Working Position.**
- **Lock BX without arrow key** for knitting the right shoulder.
- **When knitting in fairisle with lock setting BX or HX, put all pushers of the left half into the blocking rail.**
- **Make note of pusher and punchcard positions** when knitting with the DECO in order to keep the stitch pattern correct for knitting the second half.
- **Continue to knit at right with the same lock setting as so far.**

With this method there is a danger that the yarn of the last row knitted on the left half may get worn by constantly moving the lock over it. This can be avoided by knitting one or two rows with contrast yarn by hand over the stitches of the left half when dividing the work.

### Dividing the work with deckercombs

With complicated stitch patterns, thickish yarn, or if you want to protect the material, it is advisable to use this method. If you don't have enough deckercombs with your machine these are available as special accessory.

Place the stitches of the left half on to the deckercombs. In the case of double-bed knitting, place the stitches of the front and the back bed on to separate deckercombs. Before you continue to knit slide the deckercombs down between the two beds.

**Make a note of pusher and punchcard positions** in order to keep the stitch pattern correct when knitting the second half. (Depending on the stitch pattern, it may sometimes be better to divide the knitting 2 rows later, e.g. with fairisle where the first 2 rows were knitted in main colour, but the 2 rows trimming colour have to be knitted yet).



# Practical tips

## Various neckbands and polo neck collar

With each garment there is also the programme used for knitting the neckband or the collar.

If however you decide to knit the garment in a different stitch pattern or with a different yarn, it may be that the suggested neckband is no longer quite suitable. Or maybe you simply prefer a narrow neckband to the collar.

In each case you can knit your neckband with one of the programmes below.

## Measuring the neck opening

Before you knit your neckband or collar, you must first finish the front and back parts. Press the parts if required and join the shoulder seams. Now you can measure the neck opening.

## Test square for neckband or collar

It is important to knit a test square 40 stitches by 40 rows also for the neckband or collar as described on page 6. **In the case of ribs (e.g. 1:1 rib or 2:2 rib) the test square must be stretched sideways when measuring it**, so that the neckband or collar fits closely afterwards.

## Neckband or collar knitted straight

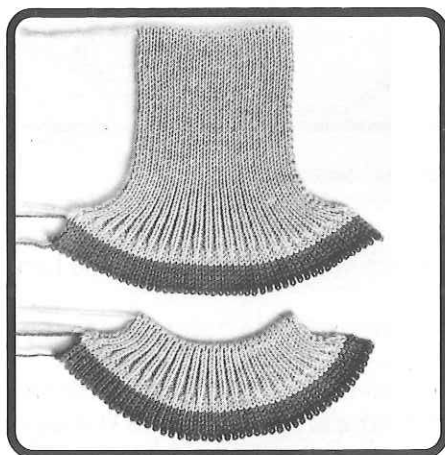

This programme can be used for all neckbands and collars which cannot be knitted tubular, and which do not have any edge increases or decreases. For example: Garments 7, 12, 21, 22, 27, 28, 30.

This programme can also be used for V-neck bands if at the end you fold the two corners to the inside and neaten the mitre in the centre.

Example: Garments 3, 9, 11.

- Enter the measurements of your test square into the programme.
- Enter the measurement in centimetres of your neckband twice at the place indicated.
- Determine the height of your neckband or collar by entering the appropriate measurement in cm at the place indicated.
- Enter the programme into the **FORM COMPUTER** as described on page 10.



# Practical tips

80
160
mm 40 R
mm 40 sts
75
30
38
75
30
6
6
cm height of band
0

## Flashing figures:

- 1 For all double-bed knitting tubular cast on, as it can be used as a neat edge for the neckband or collar.
- 5 A few rows with contrast yarn, release.  
Sewing on is made easier if at flashing figure 5 you first transfer all stitches to the front bed and knit an additional two rows with the main yarn, not forgetting to increase the stitch size accordingly. Only then knit a few rows with contrast yarn and release.

## To make up:

Press band or at least the contrast yarn. Sew band in position on the outside of neck opening, st by st, backstitching through the open loops and unravelling contrast yarn.

Join ends of band.

In the case of a neckband for a V-neck opening begin sewing at the centre front point. At the end fold the two corners of the band to the inside and neaten the mitre in the centre so that the stitches on either side are symmetrical. When joining the ends of a polo neck collar, sew the first 5 cms of the seam on the inside, then the rest on the outside. This will prevent the seam from showing when the collar is folded in half to the outside.

## Neckband or polo neck collar knitted tubular

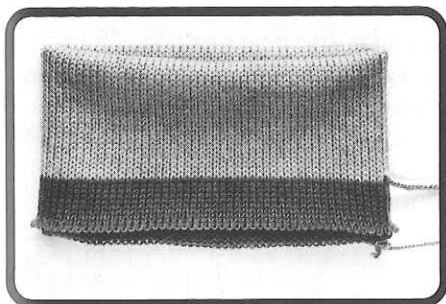

If you want to knit a neckband or collar in stocking stitch it is advisable to knit it tubular as this will save you having to join the ends.

**Test square:** Remember that for the 40 rows of the test square the row counter is relevant, i.e. when the row counter indicates 40 when knitting tubular, you will see only 20 rows on your piece of knitting.

## Flashing figures:

- 1 Press Key STOP. Cast on for tubular using contrast yarn, knit a few rows with contrast yarn.  
Bring the main yarn into the lock, press Key GO.
- 5 Knit a few rows with contrast yarn, release.  
Pressing the piece of knitting can be made easier if you end with a few rows knitted in contrast yarn tubular and then a few rows with lock back and front N.

## To make up:

Press collar or neckband. Start unravelling contrast yarn at one end and attach to outside of neck opening st by st, backstitching through the open loops. Fold in half to inside and attach in the same way, unravel contrast yarn.

80
160
mm 40 R
mm 40 sts
25
20
38
25
20
6
6
cm height of band
0



# Practical tips

## Tubular neckband for V-neck opening

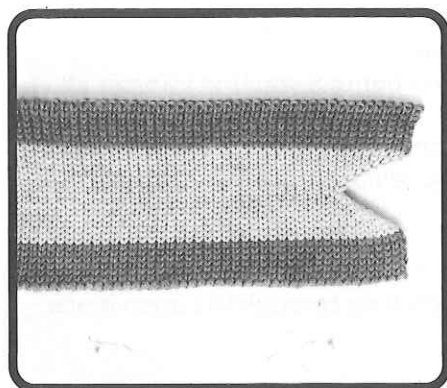

78	
146	
	mm 40 R
	mm 40 sts
41	
30	
	cm neck opening
99	
6	
70	
1	
0	

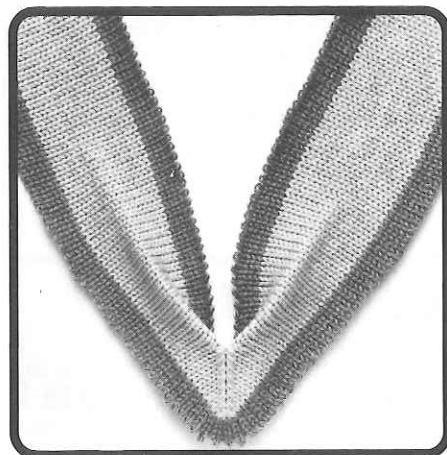

This band is knitted in stocking stitch, tubular and already correctly shaped for the V-neck opening while knitting.

Examples: Garments 1, 5, 15.

### Test square:

Remember that for the 40 rows of the test square the row counter is relevant.

### Flashing figures:

**1 Press Key STOP.** Using contrast yarn make tubular, closed cast on. Knit a few rows with contrast yarn.

Bring main yarn into the lock, **press Key GO.**

**When knitting with the main yarn decrease 1 stitch at left front and back every alternate row.**

**7 From now on increase 1 stitch at left front and back every alternate row** as follows: Bring 1 empty needle into Working Position, transfer the last stitch on to this needle, place purl stitch loop of this last stitch on to the now empty last but one needle.

**5** Knit a few rows with contrast yarn, release.

### To make up:

Take band off the machine and press as it is. Then unravel the cast on, and possibly the last few K/K-rows, if any. Fold neckband as shown in the photo. Sew in position first on the outside of the neck opening, st by st, backstitching through the open loops and unraveling contrast yarn, then in the same way to the inside.

## Abbreviations

In the following garment descriptions you will find these abbreviations for the stitch patterns:

 Racking handle down

 Racking handle up

 Racking handle in 9 o'clock position

 Black strippers

 Orange (red) strippers

2 R Knit 2 rows

4 R Knit 4 rows

 Racking handle one full turn to the right

 Racking handle two full turns to the right

 Racking handle one full turn to the left

 Rack back bed to the extreme right before commencing pattern

 Transfer stitches from back to front

 Transfer stitches from front to back

 U 80 lever position

col 1 First colour

col 2 Second colour

 With front lock alone

× When finished, unravel these stitches



# Lady's summery kimono dress

1

## Front part

34	38	42
100	100	100
136	136	136
162	170	178
96	103	108
96	103	108
max. hip size		
98	98	98
7	7	7
1	1	1
55	55	55
64	64	64
150	158	168
89	95	101
cm hip size		
46	47	47
113	116	116
cm total length dress		
107	107	107
191	191	191
131	133	133
33	33	33
71	71	71
2	2	2
3	3	3
127	127	127
3	3	3
129	130	130
33	33	33
16	16	16
232	232	231
63	63	39
128	130	29
27	29	191
191	191	143
141	143	130
129	130	190
189	190	156
153	156	68
68	68	191
191	191	153
152	153	29
27	29	6
5	6	0
0	0	

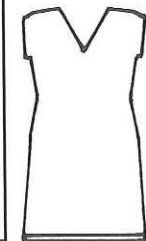

## Back

34	38	42
100	100	100
136	136	136
162	170	178
96	103	108
96	103	108
max. hip size		
98	98	98
7	7	7
1	1	1
55	55	55
64	64	64
150	158	168
89	95	101
cm hip size		
46	47	47
113	116	116
cm total length dress		
107	107	107
191	191	191
131	133	133
33	33	33
71	71	71
2	2	2
3	3	3
127	127	127
3	3	3
129	130	130
33	33	33
16	16	16
232	232	231
63	63	39
128	130	29
27	29	191
191	191	143
141	143	130
129	130	190
189	190	156
153	156	69
69	69	184
184	184	135
134	135	190
189	190	139
139	139	2
2	2	0
0	0	

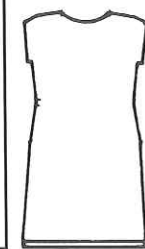

## Neckband

78
146
107
74
99
3
67
4
0

mm 40 R  
mm 40 sts  
cm neck opening

### Note:

For size 42 the test square for 40 stitches must amount to at least 136 mm. Never increase the hip size beyond the indicated maximum hip size.

### Material:

550–620 g medium mercerised cotton yarn (420 m length per 100 g, 132 yds per 1 oz).

### Stitch size:

Pattern and stocking stitch = 5, waist = 4.

### Pattern:

Tuck stitch with DECO punchcard 19.

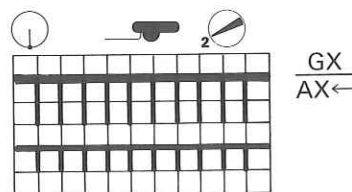

Neckband: Stocking stitch, tubular.

### Flashing figures:

- 1 Front and back part: closed cast on for tubular.  
Neckband: with contrast yarn closed cast on for tubular. When knitting with the main yarn, decrease 1 stitch at left front and back every alternate row-until flashing figure 10.
- 3 Divide work, continue to knit at right.
- 4 End of first shoulder, to knit second shoulder press key GO.
- 5 Front and back part: cast off all remaining stitches.  
Neckband: a few rows with contrast yarn, release.
- 7 Transfer all stitches to front for pattern.
- 8 For the waist transfer every alternate stitch to back bed, empty needles out of Working Position. Lock N/N, St.S 4.
- 9 Transfer all stitches to front for pattern.
- 10 Neckband: increase 1 stitch at left front and back every alternate row to the end.

### To make up:

Block and press parts. Join side and shoulder seams. Measure neck opening and knit neckband to match. Backstitch neckband st by st first to the outside of neck opening, then to inside, st by st, backstitching through the open loops and unravelling contrast yarn. Press seams.



# 2 Man's shirt style sweater, short sleeves

## Front part

48	52	56
87	87	87
166	166	166
126	136	144
96	104	112
96	104	112
195	195	195
7	7	7
6	6	6
38	38	38
126	136	144
96	104	112
31	31	31
61	62	63
232	232	233
7	7	7
2	2	2
161	161	161
153	178	187
179	162	130
146	164	162
7	7	164
34	35	7
72	72	36
160	160	73
7	7	160
34	36	7
161	161	37
178	178	169
145	145	161
146	146	178
5	5	145
0	0	146
		5
		0

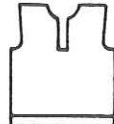

## Back

48	52	56
87	87	87
166	166	166
126	136	144
96	104	112
96	104	112
195	195	195
7	7	7
6	6	6
38	38	38
126	136	144
96	104	112
31	31	31
61	62	63
106	107	107
7	7	7
2	2	2
161	161	161
162	153	178
146	162	162
7	146	146
16	7	7
191	15	16
151	191	191
13	153	153
0	13	13
		0



## Sleeve

48	52	56
87	87	87
166	166	166
82	82	92
34	36	38
34	36	38
195	195	195
7	7	7
2	2	2
38	38	38
90	92	102
38	40	42
13	13	13
29	30	31
102	102	102
5	5	5
153	161	161
138	138	138
191	191	191
152	153	158
143	146	148
0	0	0



## Collar

48	52	56
40	40	40
144	144	144
100	106	114
3	3	3
3	3	3
101	101	101
2	2	2
191	191	191
128	128	128
31	31	31
4	4	4
0	0	0



## Front band

40
144
50
18
101
7
3
71
1
3
0

### Material:

medium mercerised cotton yarn  
(420 m length per 100 g, 132 yds per 1 oz)  
225–280 g brown, 150–200 g yellow.  
3 buttons.

### Stitch size:

Pattern = 5½, stocking stitch = 5½,  
1:1 rib = 2¾.

### Pattern:

Two-coloured tuck stitch with DECO  
punchcard 50.

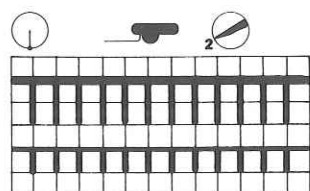

Welt and cuffs: 1:1 rib.

Collar and front bands: Stocking stitch,  
tubular.

### Flashing figures:

- 1 Front and back part, sleeves: tubular cast on for 1:1 rib.  
Collar, front bands: closed cast on for tubular.
- 2 Transfer all stitches to front bed for pattern.
- 3 Divide work, cont. to knit at right.
- 4 End of first shoulder, to knit second shoulder press key GO.
- 5 Front and back part: cast off all remaining stitches.  
Collar and front bands: a few rows with contrast yarn, release.
- 7 Work three buttonholes (3–4 sts across) spread evenly across the front band. For button band disregard 7.

### To make up:

Block and press parts. To ascertain length of front bands, measure along front edges. Then knit one band with and one band without buttonholes. Attach front bands to outside edge of front edges, st by st, backstitching through the open loops and unravelling contrast yarn. At lower edge, place front bands one over the other and sew in position with invisible stitches. Sew collar in position round neck edge as given for front bands. Join side and sleeve seams. Set in sleeves.



## Front part

34	36	40	44
80	80	80	80
148	148	148	148
132	138	146	154
84	87	93	99
84	87	93	99
195	195	195	195
7	7	7	7
7	7	7	7
38	38	38	38
132	138	146	154
84	87	93	99
34	34	34	34
62	62	63	64
235	236	236	236
7	7	7	7
3	3	3	3
169	169	169	169
153	153	178	178
179	188	188	188
146	129	129	129
7	146	146	146
28	7	7	7
191	27	29	31
146	191	191	191
3	147	148	150
67	3	3	3
191	67	67	67
146	191	191	191
42	146	146	146
0	42	45	47
	0	0	0

mm 40 R  
mm 40 sts

mm 40 R  
border

cm bust

cm total length



## Back

34	36	40	44
80	80	80	80
148	148	148	148
118	122	130	138
84	87	93	99
84	87	93	99
195	195	195	195
7	7	7	7
7	7	7	7
38	38	38	38
118	122	130	138
84	87	93	99
34	34	34	34
62	62	63	64
234	234	234	235
7	7	7	7
3	3	3	3
153	153	153	153
162	162	179	188
146	155	164	129
7	7	7	164
28	27	27	7
191	191	191	29
146	147	148	191
3	3	3	150
72	72	72	3
185	185	185	72
129	129	129	185
186	186	186	129
129	129	129	186
188	188	188	129
129	129	129	188
137	137	137	129
3	3	3	137
0	0	0	3
			0

mm 40 R  
mm 40 sts

mm 40 R  
border

cm bust

cm total length



## Sleeve

34	36	40	44
80	80	80	80
148	148	148	148
76	82	88	94
28	30	32	34
28	30	32	34
195	195	195	195
7	7	7	7
2	2	2	2
38	38	38	38
88	94	100	106
32	34	36	38
9	9	9	9
27	27	27	27
106	106	105	107
6	6	6	6
161	161	169	177
153	153	153	161
162	162	162	153
191	191	191	145
137	140	140	191
148	148	146	139
145	145	162	152
153	153	178	162
161	161	0	153
0	0		161
			0

mm 40 R  
mm 40 sts

mm 40 R  
border

cm sleeve width

cm sleeve length



## Neckband

103	
158	
	mm 40 R
	mm 40 sts
162	
64	
	cm neck opening
97	
5	
0	

### Material:

250–300 g medium mercerised cotton yarn, lemon (420 m length per 100 g, 132 yds per 1 oz).

### Stitch size:

Lace pattern back = 5, front = 4,  
1:1 rib = 2<sup>3</sup>/<sub>4</sub>.

### Pattern:

Lace pattern with DECO punchcard 85 and U70 or U80.

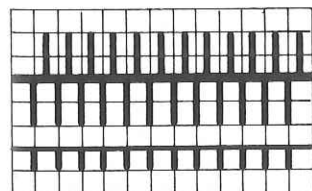

2 R N  
BX

Welt, cuffs and neckband: 1:1 rib.

### Flashing figures:

- 1 Tubular cast on for 1:1 rib.
- 2 Transfer all stitches to back bed for pattern.
- 3 Divide work, cont. to knit at right.
- 4 End of first shoulder, to knit second shoulder press key GO.
- 5 Back and front part: cast off all remaining stitches.  
Neckband: a few rows with contrast yarn, release.

### To make up:

Block and press parts. Join shoulder, side and sleeve seams. Measure neck opening and knit neckband. Sew neckband to neck opening, st by st, backstitching through the open loops and unravelling contrast yarn. Join point. Set in sleeves.



Front part

34	36	40	44	46	48	
100	100	100	100	100	100	mm 40 R
406	406	406	406	406	406	mm 40 sts
60	61	66	70	74	77	mm 40 R border
3	3	3	3	3	3	
3	3	3	3	3	3	
195	195	195	195	195	195	cm bust
7	7	7	7	7	7	cm sleeve width
6	6	6	6	6	6	cm sleeve length
38	38	38	38	38	38	
60	61	66	70	74	77	
84	87	93	99	102	108	
24	24	24	24	24	24	
59	60	62	63	63	64	
235	234	235	235	235	235	
7	7	7	7	7	7	
1	1	1	1	1	1	
161	178	161	177	177	177	
153	179	153	169	161	161	
162	146	179	162	179	179	
155	7	146	146	155	155	
7	30	7	7	7	7	
28	191	34	37	35	37	
191	150	191	191	191	191	
150	1	151	149	153	155	
1	70	1	1	1	1	
71	176	71	72	72	72	
168	161	176	184	184	184	
161	179	161	131	131	131	
153	146	153	161	169	177	
162	7	162	153	161	161	
137	3	164	145	145	145	
7	0	7	155	146	146	
4		1	7	7	7	
0		0	6	7	8	
			0	0	0	

Back

34	36	40	44	46	48	
100	100	100	100	100	100	mm 40 R
150	150	150	150	150	150	mm 40 sts
120	122	132	138	150	156	mm 40 R border
3	3	3	3	3	3	
3	3	3	3	3	3	
195	195	195	195	195	195	cm bust
7	7	7	7	7	7	cm sleeve width
6	6	6	6	6	6	cm sleeve length
38	38	38	38	38	38	
120	122	132	138	150	156	
84	87	93	99	102	108	
24	24	24	24	24	24	
59	60	62	63	63	64	
235	235	235	235	235	235	
7	7	7	7	7	7	
1	1	1	1	1	1	
161	161	161	177	177	177	
153	153	153	153	161	161	
162	162	179	162	179	179	
146	146	146	146	155	155	
7	7	7	7	7	7	
29	31	34	37	35	37	
191	191	191	191	191	191	
143	149	151	151	153	155	
1	1	1	1	1	1	
69	69	69	69	69	69	
184	184	184	184	184	184	
131	131	131	131	132	133	
153	161	161	169	169	169	
162	162	162	179	179	179	
146	146	155	146	146	146	
0	0	0	0	0	0	

Sleeve

34	36	40	44	46	48	
100	100	100	100	100	100	mm 40 R
150	150	150	150	150	150	mm 40 sts
58	62	66	70	72	74	mm 40 R border
3	3	3	3	3	3	
3	3	3	3	3	3	
195	195	195	195	195	195	cm bust
7	7	7	7	7	7	cm sleeve width
4	4	4	4	4	4	cm sleeve length
38	38	38	38	38	38	
84	88	96	106	112	118	
32	33	36	40	42	44	
36	36	36	36	36	36	
58	58	59	61	61	62	
107	107	106	106	107	107	
7	7	7	7	7	7	
1	1	1	1	1	1	
152	160	160	168	176	176	
188	188	162	162	161	161	
129	129	191	191	145	162	
191	191	146	147	191	191	
132	135	18	19	147	148	
11	11	145	162	19	20	
188	188	153	153	162	162	
129	129	161	169	153	153	
153	161	0	0	169	169	
0	0			0	0	

Material:

330–400 g fairly fine Mohair/Acrylic (475 m length per 100 g, 149 yds per 1 oz).

Stitch size:

Pattern = 5, 1 : 1 rib = 2¾, K/K = 3, tubular = 5½.

Pattern:

Single-bed tuck stitch.

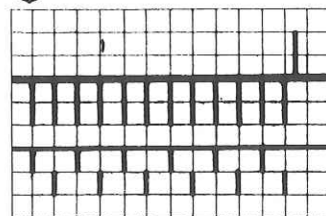

Waist and sleeve bands: 1 : 1 rib.  
Neck and front bands: K/K and tubular.

Flashing figures:

- 1 Front and back part, sleeves: tubular cast on for 1 : 1 rib.  
Front and neck bands: tubular cast on for K/K.
- 2 Transfer all stitches to front for pattern.

- 3 Divide work, continue to knit at right.
- 4 End of first shoulder, to knit second shoulder press key GO.
- 5 Cast off all remaining stitches.  
Neck and front bands: a few rows with contrast yarn, release.
- 7 Buttonhole band: work 6 buttonholes (3–4 stitches across) spread evenly across the band.  
Button band: continue to knit.  
Neckband: about 5 stitches from right edge work buttonhole as given above.
- 8 Lock front and back CX, continue to knit tubular.

To make up:

Pin parts out to size and leave to dry under damp cloth. Join shoulder, side and sleeve seams. Measure along jacket front edges and knit one buttonhole band and one button band to match. St by st, backstitch bands to front edges first on the outside, then on the inside, st by st, backstitching through the open loops and unravelling contrast yarn. Measure neck opening and knit neckband. Attach neckband as given for front bands. Set in sleeves.

Bands

75	
154	
	mm 40 R
	mm 40 sts
151	
58	
	cm band
101	
5	
67	
1	
68	
2	
0	



### Front part

34	36	40	44
80	80	80	80
148	148	148	148
120	124	134	142
3	3	3	3
3	3	3	3
195	195	195	195
7	7	7	7
1	1	1	1
38	38	38	38
120	124	134	142
84	87	93	99
32	32	32	32
60	60	61	62
231	231	231	231
5	5	5	5
56	56	56	56
129	129	129	129
7	7	7	7
48	51	51	53
189	189	189	189
165	167	170	174
67	67	67	67
191	191	191	191
145	145	147	147
38	41	41	43
0	0	0	0



### Back

34	36	40	44
80	80	80	80
148	148	148	148
120	124	134	142
3	3	3	3
3	3	3	3
195	195	195	195
7	7	7	7
1	1	1	1
38	38	38	38
120	124	134	142
84	87	93	99
32	32	32	32
60	60	61	62
231	231	231	231
5	5	5	5
56	56	56	56
129	129	129	129
7	7	7	7
48	51	51	53
189	189	189	189
165	167	170	174
70	70	70	70
185	185	185	185
131	131	133	133
177	177	177	177
161	161	161	161
162	162	162	162
2	2	2	2
0	0	0	0

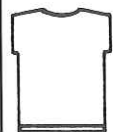

### Neckband

78
146
102
74
99
5
69
1
0

### Sleeve band

80
160
75
60
98
7
3
0

### Material:

fairly fine Mohair/Acrylic (475 m length per 100 g, 149 yds per 1 oz), 80–110 g yellow and 70–90 g pale yellow.

### Stitch size:

Pattern back = 4½, front = 5½, stocking stitch = 5½.

### Pattern:

Summer fairisle acc. to diagram with DECO punchcard 55.

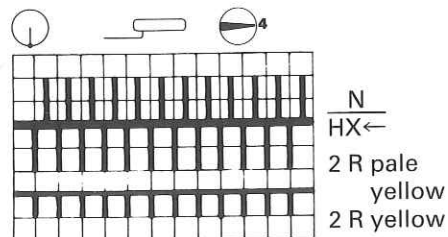

When you have finished, release and unravel all stitches knitted on the front bed.

When decreasing, release the stitches on front bed.

Waist, sleeve and neck bands: stocking stitch tubular.

### Flashing figures:

- 1 Front and back part: closed cast on for tubular. Knit tubular. Sleeve and neck bands: begin with contrast yarn, closed cast on for tubular. When knitting with main yarn, decrease 1 stitch at left front and back every alternate row until flashing figure 7.
- 2 Transfer all stitches to back for pattern.
- 3 Divide work, cont. to knit at right.
- 4 End of first shoulder, to knit second shoulder press key GO.
- 5 Front, back part: cast off all stitches of back bed, unravel stitches of front bed. Sleeve and neck bands: a few rows with contrast yarn, release.
- 7 On neckband increase 1 stitch at left front and back every alternate row until the end.

### To make up:

Block and press parts lightly. Ensure that all stitches of the front bed are unravelled. Join shoulder and side seams. Measure neck opening and armhole, knit bands, and backstitch, st by st, first to outside, then to inside, st by st, backstitching through the open loops and unravelling contrast yarn.



## Skirt part

102	
416	
	mm 40 R
	mm 40 sts
170	
68	
	skirt length
105	
7	
7	
255	
128	
201	
129	
191	
201	
1	
0	



For sizes **34 + 36** knit skirt parts 10 times.  
 For sizes **38 + 40** knit skirt parts 11 times.  
 For sizes **42 + 44** knit skirt parts 12 times.

**Note:**

For a skirt length of 68 cm, the test square for 40 sts must amount to at least 152 mm.

**Material:**

280–350 g fairly fine Mohair/Acrylic (475 m length per 100 g, 149 yds per 1 oz), 1 length waist elastic.

**Stitch size:**

front = 6, back = 4<sup>3</sup>/<sub>4</sub>.

**Pattern:**

Stocking stitch with graduations (short rows). For hem border: opposite the last 5 stitches bring 5 needles into Working Position at right on back bed. Handle down, lock back CX.

**Waistband:**

Stocking stitch, tubular. Begin with contrast yarn. With 9 needles on each bed knit tubular waist band acc. to required length (i.e. waist size + at least 10 cm), a few rows with contrast yarn, release. Press.

**Flashing figures:**

- 1** With contrast yarn cast on for stocking stitch.
- 6** To make graduations, bring all pushers into Working Position at front. Lock BX. Make the decreases as follows: when the lock is at right, bring the indicated number of pushers into Rest Position at left.
- 5** All pushers in Rest Position, lock front N. Press key GO, and repeat the programme as often as is necessary for your size. After the last repeat knit 2 more rows with main yarn. End with a few rows contrast yarn, release.

**To make up:**

Block and press skirt. Graft together beginning and end, unravel contrast yarn. Graft together waistband, insert waist elastic, unravel contrast yarn. Using green tool crochet waistband to skirt top.



### Front part

42	44	48	52	56
91	91	91	91	91
154	154	154	154	154
126	130	136	146	156
86	90	96	104	112
86	90	96	104	112
195	195	195	195	195
7	7	7	7	7
8	8	8	8	8
38	38	38	38	38
126	130	136	146	156
86	90	96	104	112
33	33	33	33	33
63	64	66	67	68
235	235	235	235	235
7	7	7	7	7
2	2	2	2	2
169	169	169	169	169
153	153	153	153	153
145	145	145	179	179
146	146	155	146	137
7	7	7	7	7
25	28	31	33	35
191	191	191	191	191
150	153	155	157	160
128	128	128	128	128
71	71	71	71	71
177	177	177	177	177
161	161	161	161	161
178	178	178	178	178
162	162	162	162	162
137	137	137	137	137
7	7	7	7	7
8	8	8	8	8
0	0	0	0	0



### Back

42	44	48	52	56
91	91	91	91	91
154	154	154	154	154
122	126	130	142	152
86	90	96	104	112
86	90	96	104	112
195	195	195	195	195
7	7	7	7	7
8	8	8	8	8
38	38	38	38	38
122	126	130	142	152
86	90	96	104	112
33	33	33	33	33
62	63	65	66	67
234	234	234	235	235
7	7	7	7	7
2	2	2	2	2
169	169	169	169	177
153	153	153	153	161
146	146	146	145	145
7	7	7	146	146
24	26	30	7	7
191	191	191	30	34
150	153	155	191	191
128	128	128	157	160
71	71	71	128	128
185	185	185	71	71
131	131	131	185	185
169	169	169	131	131
153	153	153	169	169
145	145	145	153	153
137	137	137	145	145
2	2	2	137	137
0	0	0	2	2
			0	0

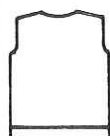

### Sleeve

42	44	48	52	56
91	91	91	91	91
154	154	154	154	154
62	68	72	78	84
24	26	28	30	32
24	26	28	30	32
195	195	195	195	195
7	7	7	7	7
8	8	8	8	8
38	38	38	38	38
88	94	98	104	110
34	36	38	40	42
40	40	40	40	40
63	63	64	64	64
103	105	104	104	106
7	7	7	7	7
2	2	2	2	2
153	153	153	153	161
191	145	145	145	153
149	191	191	191	145
21	147	150	153	191
153	19	22	25	148
0	145	162	161	20
	153	0	0	145
	0			178
				0



### Material:

fairly fine Mohair/Acrylic (475 m length per 100 g, 149 yds per 1 oz), 390–430 g green, 130–160 g pale green, 110–130 g yellow, 50–70 g brown.

### Stitch size:

Fairisle = 5, 2:2 rib = 4½.

### Pattern:

Fairisle with DECO punchcard 37.

### Colour sequence:

Rows acc. to right-hand window of card reader.

Main colour: green

- 0–20 brown
- 20–52 yellow
- 52–96 pale green
- 96–20 brown
- 20–44 yellow
- 44–76 pale green

repeat

Borders and neckband: 2:2 rib.

### Flashing figures:

- 1 Front, back part and sleeves: tubular cast on for 2:2 rib over the width of the indicated needles.  
Neckband: with contrast yarn tubular cast on for 2:2 rib.
- 2 Bring all needles into Working Position. Knit the first 2 rows with lock front and back CX, then set lock for the pattern.

### Neckband

80	
160	
	mm 40 R
	mm 40 sts
75	
30	
	cm neck opening
98	
7	
8	
0	

- 3 Divide work, continue to knit at right.
- 4 End of first shoulder, to knit second shoulder press key GO.
- 5 Front, back part and sleeves: cast off all remaining stitches.  
Neckband: a few rows with contrast yarn, release.

### To make up:

Block and press parts. Join shoulder seams. Measure neck opening, knit neckband and join in a ring. St by st, backstitch neckband first to outside of neck opening, then to inside, st by st, backstitching through the open loops and unravelling contrast yarn. Join side and sleeve seams. Set in sleeves.

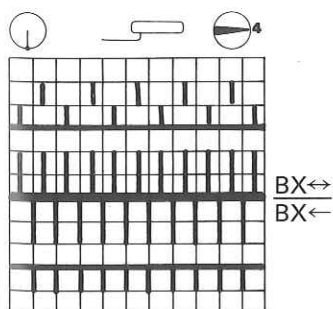

### Front part

34	38	42	46	50	54
48	48	48	48	48	48
145	145	145	145	145	145
120	126	136	144	162	178
44	46	50	53	59	65
44	46	50	53	59	65
195	195	195	195	195	195
7	7	7	7	7	7
26	26	26	26	26	26
38	38	38	38	38	38
120	126	136	144	162	178
84	90	96	102	114	128
30	30	30	30	31	31
64	64	66	68	71	73
226	226	226	226	226	226
7	7	7	7	7	7
13	13	13	13	13	13
69	69	69	69	69	69
191	191	191	191	191	191
138	138	141	142	144	145
83	91	91	101	109	109
7	7	7	7	7	7
5	5	5	5	5	5
105	104	104	104	105	107
179	190	190	190	179	179
164	133	133	133	162	188
167	164	164	164	182	129
1	7	7	7	158	182
7	66	66	76	7	167
53	191	191	191	77	1
191	151	153	156	191	7
150	5	5	5	160	80
5	0	0	0	5	191
0				0	162
					5
					0

### Back

34	38	42	46	50	54
48	48	48	48	48	48
145	145	145	145	145	145
120	126	136	144	162	178
44	46	50	53	59	65
44	46	50	53	59	65
195	195	195	195	195	195
7	7	7	7	7	7
26	26	26	26	26	26
38	38	38	38	38	38
120	126	136	144	162	178
84	90	96	102	114	128
30	30	30	30	31	31
64	64	66	68	71	73
106	107	107	107	107	108
7	7	7	7	7	7
13	13	13	13	13	13
179	179	179	179	179	179
164	164	164	164	162	188
148	167	167	167	182	129
7	1	1	1	148	182
57	7	7	7	7	158
191	61	61	70	78	7
152	191	191	191	191	82
5	153	156	159	162	191
0	5	5	5	5	164
	0	0	0	0	5
					0

### Sleeve

34	38	42	46	50	54
48	48	48	48	48	48
145	145	145	145	145	145
64	64	68	68	72	72
24	24	25	25	26	26
24	24	25	25	26	26
195	195	195	195	195	195
7	7	7	7	7	7
18	18	18	18	18	18
38	38	38	38	38	38
96	98	106	110	112	116
35	36	39	40	41	42
35	36	38	38	39	39
57	58	61	62	64	65
107	108	107	108	108	109
7	7	7	7	7	7
10	10	10	10	10	10
170	170	170	170	170	170
154	162	162	162	162	154
164	154	180	182	180	182
191	146	191	191	191	191
135	191	136	137	138	140
27	136	29	33	40	35
164	28	158	158	158	167
154	146	162	146	146	1
170	154	170	162	162	146
0	162	0	170	170	154
	0		0	0	170
					0

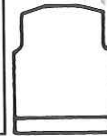

### Neckband

80	
160	
	mm 40 R
	mm 40 sts
75	
30	
	cm neck opening
98	
7	
1	
0	

### Material:

fairly fine Mohair/Acrylic (475 m length per 100 g, 149 yds per 1 oz) 280–350 g green, 80–120 g of each : pale green, salmon, yellow.

### Stitch size:

Fairisle = 5, 2 : 2 rib = 4<sup>1</sup>/<sub>2</sub>.

### Pattern:

Fairisle with DECO punchcard 48b.

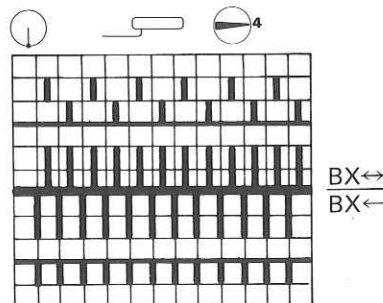

Use punchcard 48b from row 60 to the end (right-hand window of card reader).

### Colour sequence:

Main colour: green  
 Row 60–80 pale green  
 80–00 salmon  
 00–20 yellow  
 repeat

Waist, sleeve and neck bands: 2 : 2 rib.

### Flashing figures:

- 1 Tubular cast on for 2 : 2 rib.
- 2 Bring all needles into Working Position. Knit the first 2 rows tubular (lock CX/CX), then set lock for pattern.
- 3 Divide work, continue to knit at right.
- 4 End of first shoulder, to knit second shoulder press key GO.
- 5 Front part, back and sleeves: cast off all remaining stitches.  
 Neckband: a few rows with contrast yarn, release.

### To make up:

Press parts lightly. Join shoulder seams. Measure neck opening. Knit neckband and attach, st by st, backstitching through the open loops and unravelling contrast yarn. Mitre point at centre front and catch down superfluous material. Join sleeve and side seams. Set in sleeves.



# Flared skirt, knitted in three parts

9

## Skirt part, knitted three times

34	36	40	44	48	52
48	48	48	48	48	48
145	145	145	145	145	145
124	128	132	138	146	160
3	3	3	3	3	3
3	3	3	3	3	3
38	38	38	38	38	38
86	88	94	100	108	122
89	92	98	104	113	128
45	45	47	48	48	48
65	65	67	68	68	68
99	99	99	99	99	99
191	191	191	191	191	191
130	130	130	130	130	130
204	204	204	204	204	204
0	0	0	0	0	0

mm 40 R  
mm 40 sts

cm hips

cm total length



### Material:

fairly fine Mohair/Acrylic (475 m length per 100 g, 149 yds per 1 oz) 240–280 g green, 70–90 g yellow, 40–60 g pale green, 50–70 g of each: dark green, orange, salmon.

### Stitch size:

5

### Pattern:

Fairisle with DECO punchcard 48.

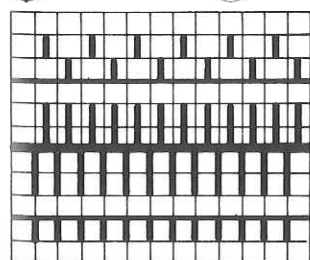
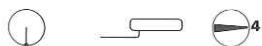

### Colour sequence:

Rows acc. to right-hand window of card reader.

Main colour: green  
Cast on: dark green  
44–08 dark green  
08–48 orange  
48–80 yellow  
80–00 dark green  
00–24 orange  
24–36 yellow  
36–60 dark green  
60–80 orange  
80–00 salmon  
00–20 yellow  
20–40 pale green

continue to repeat in salmon, yellow, pale green repeating punchcard 48 b only from 60 to the end.

### Waistband:

Tubular, stocking stitch, green. Begin with contrast yarn, with 8 needles on each bed and St.S 5. Knit tubular waist band to required length (i.e. your waist size plus at least 10 cm). End with a few rows contrast yarn, release. Press.

### Flashing figures:

- 1 Tubular cast on.
- 5 Cast off remaining stitches.

### To make up:

Block and press parts lightly. Insert waist elastic into waist band and graft together ends. Join skirt seams. Crochet waist band to waist edge of skirt. Press seams lightly.

Front part

42	46	50	54
55	55	55	55
436	436	436	436
49	54	60	62
84	92	100	108
84	92	100	108
195	195	195	195
7	7	7	7
15	15	15	15
38	38	38	38
49	54	60	62
84	92	100	108
39	40	41	41
73	75	77	78
235	235	236	236
7	7	7	7
8	8	8	8
161	169	169	169
153	153	161	161
145	145	153	153
155	155	145	145
7	7	155	146
63	67	7	7
191	191	70	73
147	151	191	191
5	5	153	155
69	69	5	5
191	191	69	69
132	132	191	191
73	77	132	133
7	7	81	83
5	5	7	7
0	0	5	5
		0	0



Back

42	46	50	54
55	55	55	55
180	180	180	180
104	116	128	130
84	92	100	108
84	92	100	108
195	195	195	195
7	7	7	7
15	15	15	15
38	38	38	38
104	116	128	130
84	92	100	108
39	40	41	41
73	75	77	78
106	107	107	107
7	7	7	7
8	8	8	8
153	161	161	161
162	153	153	153
139	145	162	162
7	146	146	146
63	7	7	7
191	66	70	74
149	191	191	191
5	153	156	158
0	5	5	5
	0	0	0

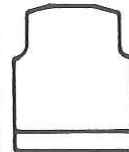

Sleeve

42	46	50	54
55	55	55	55
180	180	180	180
48	54	58	58
22	24	26	26
22	24	26	26
195	195	195	195
7	7	7	7
15	15	15	15
38	38	38	38
80	90	98	100
36	40	44	45
35	35	36	36
59	61	63	64
108	107	109	109
7	7	7	7
8	8	8	8
161	169	169	169
153	153	161	161
146	145	153	153
191	191	145	145
135	142	191	191
34	42	136	136
146	145	43	48
145	153	162	155
153	161	153	145
161	0	161	161
0		169	169
		0	0

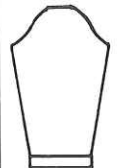

Material:

fairly fine Mohair/Acrylic (475 m length per 100 g, 149 yds per 1 oz) 280–320 g dark green, 180–210 g pale green, 6 buttons.

Stitch size:

Pattern = 5 1/2, K/K = 3 1/2.

Pattern:

AX-pattern acc. to diagram.

Flashing figures:

- 1 Tubular cast on for K/K.
- 2 Transfer stitches for pattern acc. to diagram.
- 5 Front part, back and sleeves: cast off all remaining stitches. For second front part: after pressing key GO, press key for "mirroring". Front band: a few rows with contrast yarn, release.

Note: Front band:

The message "+ 1" means that here you have to work a buttonhole over 8 stitches.

To make up:

Block and press parts lightly. Join shoulder, side and sleeve seams. Set in sleeves. Take measurement for front band and knit band accordingly. With right sides facing sew in position along front and back edge. Unravel contrast yarn, and if necessary superfluous rows. Neaten loose stitches. Attach buttons.

Front band

90	
259	
	mm 40 R
3	
12	
3	
3	
99	
7	
7	
8	
38	
24	
3	
3	
39	
179	
179	
38	
18	
3	
3	
134	
179	
	cm total length
0	

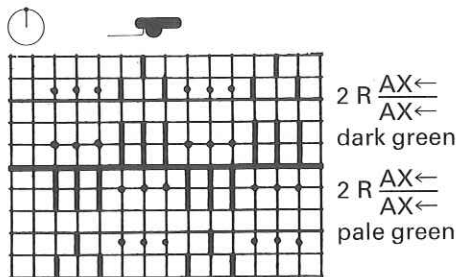

Welt and bands: K/K.



## Front part

36	38	40
88	88	88
132	132	132
138	144	150
3	3	3
3	3	3
195	195	195
7	7	7
24	24	24
38	38	38
138	144	150
87	90	93
21	21	21
60	61	62
236	236	236
7	7	7
3	3	3
169	169	169
161	161	161
153	153	153
179	179	179
155	164	173
7	7	7
27	30	31
191	191	191
139	141	143
128	128	128
67	67	67
191	191	191
151	151	151
50	54	56
0	0	0



## Back

36	38	40
88	88	88
132	132	132
138	144	150
3	3	3
3	3	3
195	195	195
7	7	7
24	24	24
38	38	38
138	144	150
87	90	93
21	21	21
60	61	62
107	107	108
7	7	7
3	3	3
169	169	169
153	153	153
179	179	188
164	173	129
7	7	164
28	30	7
191	191	32
142	144	191
128	128	147
0	0	128
		0

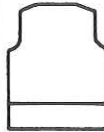

## Bands

80	
160	
	mm 40 R
	mm 40 sts
75	
30	
	cm band
98	
7	
1	
0	

### Material:

fairly fine Mohair/Acrylic  
(475 m length per 100 g, 149 yds per 1 oz)  
110–140 g rust, 40–60 g each: dark  
green, pale green, yellow.

### Stitch size:

Tuck stitch = 4<sup>1</sup>/<sub>2</sub>, K/K = 3<sup>3</sup>/<sub>4</sub>.

### Pattern:

4-coloured tuck stitch pattern with  
DECO punchcard 60.

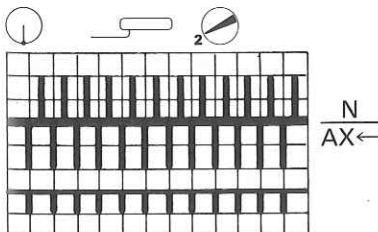

**Colour sequence:** 2 R dark green  
4 R yellow  
2 R dark green  
4 R pale green  
2 R dark green  
4 R rust  
repeat

Waist, neck and armhole bands: K/K.

### Flashing figures:

- 1 Tubular cast on for K/K.
- 2 At front all pushers in Working Position. Set lock for pattern.
- 3 Divide work, continue to knit at right.
- 4 End of first shoulder, to knit second shoulder press key GO.
- 5 Front part, back: cast off all remaining stitches.  
Neck and armhole bands: a few rows with contrast yarn, release.

### To make up:

Block and press parts lightly. Join shoulder and side seams. Measure neck and armhole openings and knit bands to required length. Sew bands in position round neck and armhole openings, st by st, backstitching through the open loops and unravelling contrast yarn. Mitre points on neck and armhole bands, catching down superfluous material on inside.

### Front part

34	36	40	44
87	87	87	87
133	133	133	133
134	142	150	158
84	87	93	99
84	87	93	99
195	195	195	195
7	7	7	7
11	11	11	11
38	38	38	38
134	142	150	158
84	87	93	99
26	26	26	26
61	61	62	63
229	229	229	229
7	7	7	7
2	2	2	2
191	191	191	191
167	171	175	179
47	47	48	52
70	70	70	70
169	169	169	169
189	189	189	189
131	131	131	131
182	182	182	182
7	7	7	7
1	1	1	2
0	0	0	0

mm 40 R  
mm 40 sts  
mm 40 R border  
cm bust  
cm total length

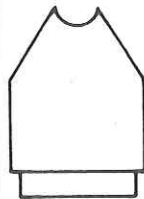

### Back

34	36	40	44
87	87	87	87
133	133	133	133
134	142	150	158
84	87	93	99
84	87	93	99
195	195	195	195
7	7	7	7
11	11	11	11
38	38	38	38
134	142	150	158
84	87	93	99
26	26	26	26
61	61	62	63
101	101	101	101
7	7	7	7
2	2	2	2
191	191	191	191
169	173	177	181
51	51	52	56
0	0	0	0

mm 40 R  
mm 40 sts  
mm 40 R border  
cm bust  
cm total length

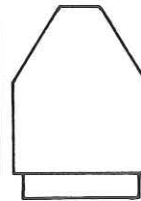

### Polo neck

80	
160	
	mm 40 R
	mm 40 sts
75	
30	
	cm neck opening
98	
7	
53	
0	

### Sleeve

(knit 2<sup>nd</sup> sleeve with reversed shapings)

34	36	40	44
87	87	87	87
133	133	133	133
74	74	78	82
24	24	26	28
24	24	26	28
195	195	195	195
7	7	7	7
11	11	11	11
38	38	38	38
110	118	126	134
36	38	41	44
35	35	35	35
56	57	58	59
69	69	69	69
7	7	7	7
2	2	2	2
191	191	191	191
168	172	176	180
51	51	52	56
71	71	71	71
7	7	7	7
2	2	2	2
191	191	191	191
168	172	176	180
47	47	48	52
188	188	188	188
137	137	137	137
0	0	0	0

mm 40 R  
mm 40 sts  
mm 40 R border  
cm sleeve width  
cm sleeve length

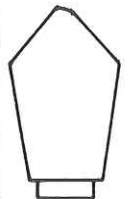

### Material:

fairly fine Mohair/Acrylic  
(475 m length per 100 g, 149 yds per 1 oz)  
170–200 g pale green, 60–80 g each:  
dark green, yellow, rust.

### Stitch size:

Pattern = 5½, 1:1 rib = 2¾.

### Pattern:

Stripes in 4 colours.

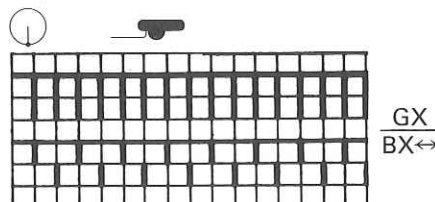

2 R pale green  
2 R contrast colour  
Change contrast colour always after  
20 rows as follows: dark green, yellow,  
rust.

Welt, cuffs, collar: 1:1 rib.

### Flashing figures:

- 1 Tubular cast on for 1:1 rib.
- 2 Transfer all stitches to front bed for pattern.
- 3 Divide work, continue to knit at right.
- 4 End of first shoulder, to knit second shoulder press key GO.
- 5 Front part, back and sleeves: cast off all remaining stitches.  
Collar: a few rows contrast yarn, release.

### To make up:

Block and press all parts. Sew sleeves with mattress stitch between back and front parts, with shorter edge at the front. Measure neck opening, knit collar and attach to outside of neck opening st by st, backstitching through the open loops and unravelling contrast yarn. Close collar seam. Join sleeve and side seams.



## Front part

34	38	42	46
40	40	40	40
160	160	160	160
116	126	134	140
89	95	101	107
166	166	166	166
116	126	134	140
84	90	96	102
89	90	90	90
110	113	114	115
72	72	72	72
7	7	7	7
73	83	88	91
184	184	184	184
131	133	134	136
174	182	182	182
182	166	166	180
	7	7	7
	16	16	19
104	104	104	104
6	6	6	6
184	184	184	184
135	139	139	139
	7	7	7
83	93	98	103
191	191	191	191
144	144	146	148
	8	8	8
	0	0	0



## Back

34	38	42	46
40	40	40	40
160	160	160	160
116	126	134	140
89	95	101	107
38	38	38	38
116	126	134	140
84	90	96	102
89	90	90	90
110	113	114	115
104	104	104	104
6	6	6	6
184	184	184	184
134	136	138	138
	7	7	7
83	93	98	103
191	191	191	191
144	146	147	149
	8	8	8
	0	0	0



## Sleeve

34	38	42	46
40	40	40	40
160	160	160	160
50	50	53	55
20	20	21	22
20	20	21	22
38	38	38	38
90	100	105	110
36	40	42	44
36	40	42	44
41	43	44	44
49	51	52	52
98	98	98	98
7	7	7	7
33	33	33	33
0	0	0	0



## Front band

80	
160	
	mm 40 R
	mm 40 sts
75	
30	
	cm band
98	
7	
1	
0	

## Collar

80	
160	
	mm 40 R
	mm 40 sts
130	
52	
52	
38	
75	
30	
	cm neck opening
13	
14	
14	
98	
70	
1	
0	

## Material:

fairly fine Mohair/Acrylic  
(475 m length per 100 g, 149 yds per 1 oz)  
350–450 g petrol blue, 280–320 g black,  
200–240 g each: pale rust and rust.

## Stitch size:

Pattern = 4½, stocking stitch, tubular = 5.

## Pattern:

4-coloured fairisle with DECO punch-card 94.

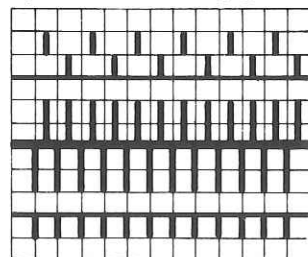

BX↔  
BX

**Colour sequence:** 2 R petrol blue  
2 R pale rust  
2 R black  
2 R rust

Front band: Stocking stitch, tubular.

## Flashing figures:

- 1 Front part, back, sleeves and collar: petrol blue, tubular cast on with all needles.  
Neckband: closed cast on for tubular.
- 3 Divide work, continue to knit at right.
- 4 End of first shoulder, to knit second shoulder press key GO.
- 5 Front part, back and sleeves: cast off all remaining stitches.  
Collar and front bands: a few rows contrast yarn, release.
- 7 Continue to knit tubular.

## To make up:

Block and press parts. Join shoulder seams. Measure neck opening and knit collar to fit. Backstitch collar st by st first to the outside of neck opening, then to inside, st by st, backstitching through the open loops and unravelling contrast yarn. Measure front slit for front bands. Knit front bands and attach as given for collar. Set in sleeves, then join side and sleeve seams.





## Front part

36	40	44
78	78	78
146	146	146
178	178	178
118	118	118
118	118	118
38	38	38
136	146	154
92	98	104
58	58	58
70	72	72
99	99	99
191	191	191
137	137	137
32	37	37
38	38	38
124	132	140
87	93	99
19	19	19
41	42	42
234	234	234
6	6	6
161	161	161
153	178	178
145	145	162
146	155	155
7	7	7
33	33	34
191	191	191
148	148	148
1	1	1
69	69	69
191	191	191
142	142	142
40	42	43
7	7	7
1	1	1
0	0	0

mm 40 R  
mm 40 sts

cm hips

cm skirt length

cm bust

cm length nape  
of neck to waist



## Back

36	40	44
78	78	78
146	146	146
178	178	178
118	118	118
118	118	118
38	38	38
136	146	154
92	98	104
58	58	58
70	72	72
99	99	99
191	191	191
137	137	137
32	37	37
38	38	38
124	132	140
87	93	99
19	19	19
41	42	42
106	106	106
6	6	6
161	161	161
153	178	178
145	145	162
146	155	155
7	7	7
32	32	33
191	191	191
148	148	148
1	1	1
0	0	0

mm 40 R  
mm 40 sts

cm hips

cm skirt length

cm bust

cm length nape  
of neck to waist



## Sleeve

36	40	44
78	78	78
146	146	146
60	60	60
3	3	3
3	3	3
98	98	98
7	7	7
1	1	1
55	55	55
64	64	64
94	102	110
34	37	40
35	38	38
56	59	60
106	106	106
7	7	7
6	6	6
161	161	161
153	153	153
145	145	145
191	191	191
144	147	150
159	159	161
145	145	145
153	153	153
0	0	0

mm 40 R  
mm 40 sts

cm sleeve width

cm sleeve length



## Neckband

78
146
102
74
99
5
69
2
0

mm 40 R  
mm 40 sts

cm neck opening

## Material:

fairly fine Mohair/Acrylic  
(475 m length per 100 g, 149 yds per 1 oz)  
340–400 g petrol blue, 70–100 g each:  
black, brown, beige.

## Stitch size:

5.

## Pattern:

4-coloured tuck stitch pattern acc. to diagram.

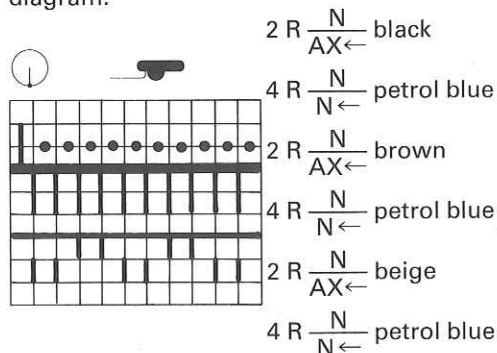

Sleeve hem and neckband: stocking stitch,  
tubular.

## Flashing figures:

- 1 Front part and back: contrast yarn, cast on for stocking stitch. Sleeves: closed cast on for tubular. Neckband: contrast yarn, closed cast on for tubular. When knitting with the main yarn, until flashing figure 8 always decrease 1 stitch front and back at left every alternate row.
- 3 Divide work, continue to knit at right.
- 4 End of first shoulder, to knit second shoulder press key GO.
- 5 Front part, back and sleeves: cast off all remaining stitches. Neckband: a few rows with contrast yarn, release.
- 7 Sleeves: transfer all stitches from back bed to front and set lock for pattern.
- 8 Neckband: every alternate row at left front and back increase 1 stitch to the end.

## To make up:

Block and press parts lightly. Join shoulder seams. Measure neck opening and knit neckband to match. St by st, backstitch to neck opening first on the outside, then to inside, st by st, backstitching through the open loops and unravelling contrast yarn. Join side and sleeve seams. Set in sleeves. Make hem as required, unravel contrast yarn.

Front part

44	48	52	56
136	136	136	136
176	176	176	176
102	106	116	126
45	47	51	55
45	47	51	55
195	195	195	195
7	7	7	7
3	3	3	3
38	38	38	38
108	114	124	132
90	96	104	112
30	31	31	31
64	67	67	67
233	233	233	234
6	6	6	6
161	161	161	169
153	153	153	161
145	145	162	153
146	137	146	145
7	7	7	137
21	21	20	7
188	188	188	22
145	146	147	189
73	73	73	148
136	136	136	73
7	7	7	136
12	12	12	7
185	185	185	12
129	130	130	185
153	153	153	130
145	145	146	153
173	182	182	146
4	4	3	182
0	0	0	5
			0

mm 40 R  
mm 40 sts

mm 40 R  
border

cm chest

cm total length



Back

44	48	52	56
136	136	136	136
176	176	176	176
102	106	116	126
45	47	51	55
45	47	51	55
195	195	195	195
7	7	7	7
3	3	3	3
38	38	38	38
108	114	124	132
90	96	104	112
30	31	31	31
64	67	67	67
104	104	105	105
6	6	6	6
161	161	161	169
153	153	153	161
145	145	162	153
7	7	137	145
23	22	7	7
188	188	21	23
145	146	188	189
0	0	147	148
		0	0

mm 40 R  
mm 40 sts

mm 40 R  
border

cm chest

cm total length

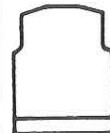

Sleeve

44	48	52	56
136	136	136	136
176	176	176	176
52	54	58	62
3	3	3	3
3	3	3	3
195	195	195	195
7	7	7	7
7	7	7	7
38	38	38	38
86	92	96	100
38	40	42	44
33	34	34	34
59	61	61	62
106	107	107	107
6	6	6	6
161	161	161	169
153	153	153	161
145	145	162	145
191	191	191	191
135	135	135	137
135	135	135	137
145	145	145	145
178	153	153	153
161	161	161	161
0	169	169	169
	0	0	0

mm 40 R  
mm 40 sts

mm 40 R  
border

cm sleeve width

cm sleeve length



Collar

136
176
92
40
98
7
20
0

mm 40 R  
mm 40 sts

cm neck  
opening

Front band

100
166
60
25
97
4
0

mm 40 R  
mm 40 sts

cm band

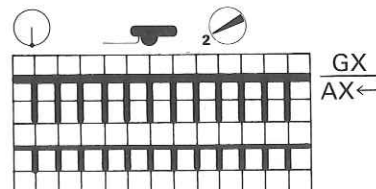

**Colour sequence:** 2 R petrol blue  
2 R black  
2 R pale rust  
2 R black  
2 R rust  
2 R black

Waistband and cuffs: 1 : 1 rib.  
Front bands: stocking stitch, tubular.

Material:

fairly fine Mohair/Acrylic  
(475 m length per 100 g, 149 yds per 1 oz)  
150–200 g black, 70–100 g petrol blue,  
50–70 g rust, 50–70 g pale rust, 1 zip  
16 cm long.

Stitch size:

Pattern = 5½, 1 : 1 rib = 3,  
stocking stitch = 5½.

Pattern:

4-coloured tuck stitch pattern with  
DECO punchcard 30.

Flashing figures:

- 1 Front part, back and sleeves: tubular cast on for 1 : 1 rib.  
Collar and front bands: single-bed cast on with contrast yarn.
- 2 Transfer all stitches to front bed for pattern.
- 3 Divide work, continue to knit at right.
- 4 End of first shoulder, to knit second shoulder press key GO.
- 5 Cast off all remaining stitches.  
Collar and front bands: a few rows contrast yarn, release.

To make up:

Block and press parts lightly. Join shoulder seams. Measure neck opening and knit collar. Attach collar to outside of neck opening, st by st, backstitching through the open loops and unravelling contrast yarn. Fold in half to inside and sew in position, unravel contrast yarn. Measure front edges and knit two front bands to match. Attach as given for collar. Join sleeve and side seams. Set in sleeves. Sew zip in position at front.



### Front part (knit two symmetrical parts)

38	44	48	52
72	72	72	72
416	416	416	416
81	84	89	98
33	34	36	38
33	34	36	38
38	38	38	38
61	64	69	78
90	99	108	122
70	74	70	68
118	122	122	122
237	237	236	238
7	7	7	7
49	49	49	49
170	170	170	170
154	154	182	162
164	164	191	154
191	191	128	182
128	128	7	191
7	7	7	128
7	7	52	7
44	44	191	7
191	191	156	53
150	152	5	191
5	5	73	156
72	72	184	5
184	184	131	74
131	131	172	184
162	162	164	131
164	164	175	172
175	183	3	164
3	3	149	191
7	7	7	130
9	7	7	5
0	0	0	158
			7
			5
			0

mm 40 R  
mm 40 sts

cm bust

cm total length



### Back (knit two symmetrical parts)

38	44	48	52
72	72	72	72
336	336	336	336
150	155	165	178
30	31	33	36
30	31	33	36
38	38	38	38
110	115	125	146
90	99	108	122
70	74	70	68
118	122	122	122
111	111	110	111
7	7	7	7
49	49	49	49
186	186	186	186
129	129	128	131
178	178	190	186
162	162	133	129
154	154	191	178
191	191	135	190
135	135	135	133
135	135	7	180
7	7	53	7
43	43	191	60
191	191	193	191
185	188	5	193
5	5	0	5
0	0	0	0

mm 40 R  
mm 40 sts

cm bust

cm total length



### Sleeve

38	44	48	52
72	72	72	72
160	160	160	160
86	86	90	90
34	34	36	36
34	34	36	36
38	38	38	38
110	110	125	128
44	44	50	51
35	37	37	38
64	66	68	69
110	110	109	109
7	7	7	7
21	21	21	21
170	170	170	170
154	154	162	162
164	164	154	154
159	159	166	166
130	130	191	191
191	191	139	140
132	132	29	31
15	15	166	166
150	150	154	154
164	164	162	162
154	154	170	170
170	170	0	0
0	0		

mm 40 R  
mm 40 sts

cm sleeve width

cm sleeve length



### Material:

fairly fine yarn  
(530 m length per 100 g, 166 yds per 1 oz)  
450–500 g offwhite, 400–500 g brown,  
340–400 g olive, 350–400 g ochre.

### Stitch size:

Fairisle back =  $3\frac{3}{4}$ , front =  $4\frac{1}{2}$ ,  
stocking stitch =  $5\frac{1}{2}$ .

### Pattern:

4-coloured fairisle with DECO punch-  
card 93.

### Flashing figures:

- 1 Front part, back, sleeves and collar: brown, tubular cast on with all needles. Knit 6 rows tubular. Front bands: contrast yarn, cast on for half tubular, open at right.
- 5 Front part, back, sleeves, collar: cast off all remaining stitches. Front band: a few rows with contrast yarn, release.
- 7 Collar: tubular, continue to knit in brown.

### To make up:

Block and press parts. Join back, side and sleeve seams. Measure neck opening and knit collar accordingly. Should your test square not result in the required width, knit the collar in two parts. Then, st by st, backstitch to outside of neck opening, then to inside, st by st, backstitching through the open loops and unravelling contrast yarn. Measure along front edges of coat and knit front band to match, in half tubular. Attach as given for collar. Join sleeve seams and set in sleeves.

### Band

80
160
75
60
98
7
1
0

mm 40 R  
mm 40 sts  
cm band

### Collar

78
146
102
37
100
7
6
68
1
0

mm 40 R  
mm 40 sts  
cm neck opening

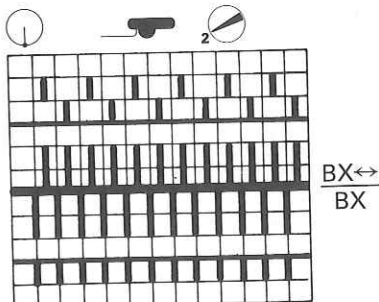

**Colour sequence:** 2 R brown  
2 R offwhite  
2 R olive  
2 R ochre

Front bands: Stocking stitch, tubular.





## Front part

36	40	44
47	47	47
387	387	387
92	104	110
87	93	99
38	38	38
92	104	110
87	93	99
43	45	45
72	76	77
230	230	230
7	7	7
14	14	14
184	184	184
136	136	136
7	7	7
95	103	108
67	67	67
191	191	191
155	161	161
78	86	91
0	0	0

mm 40 R  
mm 40 sts

cm bust

cm total length



## Back

36	40	44
47	47	47
131	131	131
144	168	178
87	93	99
38	38	38
144	168	178
87	93	99
43	45	45
72	76	77
102	102	102
7	7	7
14	14	14
184	184	184
136	136	136
7	7	7
95	103	108
0	0	0

mm 40 R  
mm 40 sts

cm bust

cm total length

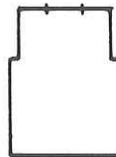

## Sleeve

36	40	44
47	47	47
131	131	131
86	86	86
28	28	28
28	28	28
38	38	38
148	158	166
57	58	59
57	58	59
44	47	48
50	53	54
98	98	98
7	7	7
16	16	16
0	0	0

mm 40 R  
mm 40 sts

cm sleeve length



## Collar

36	40	44
50	50	50
132	132	132
104	104	104
35	35	35
35	35	35
227	227	227
7	7	7
127	127	127
146	154	159
69	69	69
184	184	184
135	135	136
191	191	191
158	159	158
78	86	91
0	0	0

mm 40 R  
mm 40 sts



### Material:

1600–2000 g medium yarn  
(370 m length per 100 g, 116 yds per 1 oz).

### Stitch size:

Pin tuck pattern back = 4½, front = 4,  
Pattern collar = 5½.

### Pattern:

Pin tuck pattern with DECO  
punchcard 76.

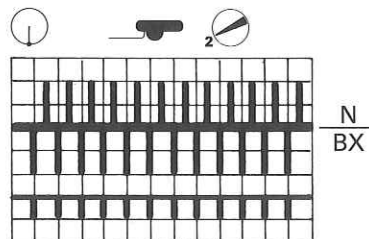

Pattern collar.

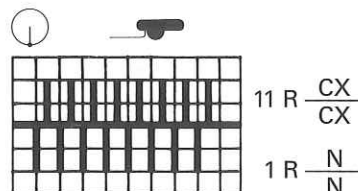

### Flashing figures:

- 1 Front part, back and sleeves: tubular cast on with all needles.  
Collar: closed cast on for tubular.
- 3 Collar: divide work, continue to knit at right.
- 4 End of first lapel, to knit second lapel press key GO.
- 5 Cast off all remaining stitches.

### To make up:

Block and press parts lightly. Join shoulder seams. Set in sleeves. Join side and sleeve seams. With right sides facing, sew collar in position.

36	38	40	42
88	88	88	88
132	132	132	132
168	174	178	178
104	108	109	109
104	108	109	109
38	38	38	38
144	150	156	164
92	95	98	101
55	55	55	55
75	75	75	75
99	99	99	99
191	191	191	191
133	133	133	133
39	39	39	39
0	0	0	0

mm 40 R

mm 40 sts

max. hip size

cm hips

cm skirt length

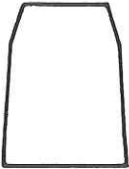
**Note:**

For sizes 40 and 42 the test square for 40 stitches must result in at least 132 mm. Never increase the measurements for the hips beyond the maximum hip measurement.

**Material:**

360–420 g medium yarn  
(370 m length per 100, 116 yds per 1 oz).

**Stitch size:**

5<sup>3</sup>/<sub>4</sub>.

**Pattern:**

Stocking stitch, tubular.

**Flashing figures:**

**1** Contrast yarn, closed cast on for tubular.

Note: Decrease with 20-deckercomb.

**5** Cast off all remaining stitches.

**To make up:**

Knit waistband with 8 needles on each bed, stocking stitch, tubular (waist size + at least 10 cm), begin and end with contrast yarn. Block and press parts. Insert elastic into waistband, close waistband with graft stitch, unravel contrast yarn. Attach waistband to skirt top. Make hem as required, unravel contrast yarn.



## Front part

34	38	40	44
139	139	139	139
165	165	165	165
116	124	128	134
84	90	93	99
84	90	93	99
195	195	195	195
7	7	7	7
2	2	2	2
38	38	38	38
116	124	128	134
84	90	93	99
34	34	34	34
62	63	64	66
229	229	229	229
6	6	6	6
184	184	184	184
131	131	131	131
7	7	7	7
19	20	21	25
70	70	70	70
176	176	176	176
186	186	186	186
129	129	129	129
179	179	179	179
164	164	164	164
5	5	5	5
0	0	0	0

mm 40 R  
mm 40 sts

mm 40 R  
border

cm bust

cm total length



## Back

34	38	40	44
139	139	139	139
165	165	165	165
116	124	128	134
84	90	93	99
84	90	93	99
195	195	195	195
7	7	7	7
2	2	2	2
38	38	38	38
116	124	128	134
84	90	93	99
34	34	34	34
62	63	64	66
229	229	229	229
6	6	6	6
184	184	184	184
131	131	131	131
7	7	7	7
19	20	21	25
70	70	70	70
176	176	176	176
186	186	186	186
129	129	129	129
189	189	189	189
131	131	131	131
2	2	2	2
0	0	0	0

mm 40 R  
mm 40 sts

mm 40 R  
border

cm bust

cm total length

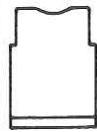

## Sleeve

34	38	40	44
139	139	139	139
165	165	165	165
58	58	58	58
24	24	24	24
24	24	24	24
195	195	195	195
7	7	7	7
2	2	2	2
38	38	38	38
90	94	100	110
37	39	41	45
37	39	41	45
42	42	42	42
56	57	58	59
98	98	98	98
7	7	7	7
2	2	2	2
0	0	0	0

mm 40 R  
mm 40 sts

mm 40 R  
border

cm sleeve length



## Polo neck

103
158
162
64
98
7
28
0

mm 40 R  
mm 40 sts

cm neck opening

## Material:

medium yarn  
(390 m length per 100 g, 122 yds per 1 oz)  
360–400 g white, 150–180 g donkey,  
190–220 g rust.

## Stitch size:

AX-fairisle = 5½, 2:2 rib = 5.

## Pattern:

AX-fairisle with DECO punchcard 9.

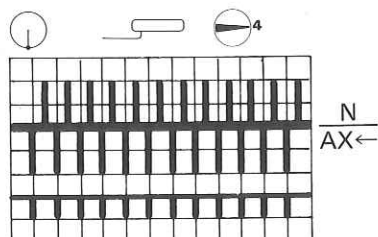

## Colour sequence:

Rows acc. to right-hand window of card reader.

Main colour: white  
0–72 donkey  
72–64 rust  
64–40 donkey  
40–72 rust

Collar: AX-fairisle acc. to diagram, but without punchcard.

Colour sequence: 2 R white, 2 R donkey.  
Welt and cuffs: 2:2 rib.

## Flashing figures:

- Front part, back and sleeves: tubular cast on for 2:2 rib.  
Collar: tubular cast on with all needles for AX-fairisle.
- Bring all needles into Working Position. Knit the first 2 rows with lock front and back CX. Then set lock for pattern.

3 Divide work, continue to knit at right.

4 End of first shoulder, to knit second shoulder press key GO.

5 Front part, back and sleeves: cast off all remaining stitches.

Collar: 2 rows with lock N/N, white, then a few rows contrast yarn, release.

## To make up:

Join shoulder seams. Measure neck opening and knit collar. Backstitch collar to outside of neck opening, st by st, then to inside, st by st, backstitching through the open loops and unravelling contrast yarn. Close collar. Set in sleeves. Join side and sleeve seams.

# 22 Man's sweater with sleeves set in straight

## Front part

42	46	50	54
50	50	50	50
220	220	220	220
86	92	100	108
84	92	100	108
84	92	100	108
195	195	195	195
7	7	7	7
37	37	37	37
38	38	38	38
86	92	100	108
84	92	100	108
42	42	43	43
64	64	65	65
229	229	229	229
7	7	7	7
33	33	33	33
191	191	191	191
150	152	154	157
4	4	4	4
70	71	71	71
152	152	160	168
172	162	172	172
183	146	191	191
5	183	129	129
7	5	9	9
10	7	7	7
0	10	6	6
	0	0	0

mm 40 R  
mm 40 sts

mm 40 R  
border

cm chest

cm total length

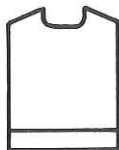

## Back

42	46	50	54
50	50	50	50
220	220	220	220
86	92	100	108
84	92	100	108
84	92	100	108
195	195	195	195
7	7	7	7
37	37	37	37
38	38	38	38
86	92	100	108
84	92	100	108
42	42	43	43
64	64	65	65
101	101	101	101
7	7	7	7
33	33	33	33
191	191	191	191
150	152	154	157
4	4	4	4
0	0	0	0

mm 40 R  
mm 40 sts

mm 40 R  
border

cm chest

cm total length

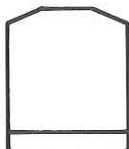

## Sleeve

42	46	50	54
50	50	50	50
220	220	220	220
60	60	60	60
33	33	33	33
33	33	33	33
195	195	195	195
7	7	7	7
37	37	37	37
38	38	38	38
72	76	80	86
40	42	44	46
40	40	40	40
60	61	62	63
98	98	98	98
7	7	7	7
9	9	9	9
0	0	0	0

mm 40 R  
mm 40 sts

mm 40 R  
border

cm sleeve width

cm sleeve length



## Polo neck

103
158
162
64
98
7
32
0

mm 40 R  
mm 40 sts

cm neck opening

## Material:

1050–1200 g medium yarn  
(390 m length per 100 g, 122 yds per 1 oz).

## Stitch size:

AX-pattern and K/K = 4½.

## Pattern:

AX-pattern with DECO punchcard 40.

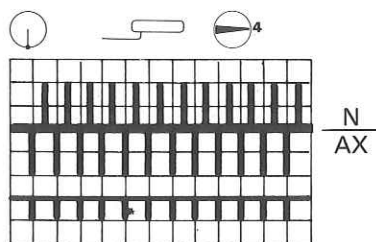

Border and polo neck: K/K.

## Flashing figures:

- 1 Tubular cast on for K/K.
- 2 Set lock for pattern.
- 3 Divide work, continue to knit at right.
- 4 End of first shoulder, to knit second shoulder press key GO.
- 5 Front part, back and sleeves: cast off all remaining stitches.  
Collar: a few rows with contrast yarn, release.

## To make up:

Join shoulder seams. Measure neck opening and knit collar to fit. Attach collar to outside of neck opening, st by st, backstitching through the open loops and unravelling contrast yarn. Close collar. Set in sleeves. Join side and sleeve seams.



## Front part

36	40	44
78	78	78
146	146	146
178	178	178
118	118	118
118	118	118
38	38	38
136	146	154
92	98	104
58	58	58
70	72	72
99	99	99
191	191	191
137	137	137
32	37	37
38	38	38
124	132	140
87	93	99
19	19	18
41	41	41
234	234	234
6	6	6
169	169	169
153	178	178
162	162	179
137	146	146
7	7	7
32	32	33
191	191	191
150	150	150
1	1	1
72	72	72
184	184	184
130	130	130
161	161	161
153	153	153
145	145	145
146	155	164
7	7	7
8	8	8
0	0	0

mm 40 R  
mm 40 sts

cm hips

cm skirt length

cm bust

cm back length



## Back

36	40	44
78	78	78
146	146	146
178	178	178
118	118	118
118	118	118
38	38	38
136	146	154
92	98	104
58	58	58
70	72	72
99	99	99
191	191	191
137	137	137
32	37	37
38	38	38
124	132	140
87	93	99
19	19	18
41	41	41
106	106	106
6	6	6
161	161	161
153	178	178
145	145	162
146	155	155
7	7	7
32	32	33
191	191	191
148	148	148
1	1	1
0	0	0

mm 40 R  
mm 40 sts

cm hips

cm skirt length

cm bust

cm back length

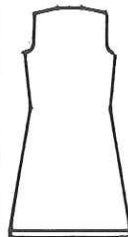

## Sleeve

36	40	44
78	78	78
146	146	146
60	60	60
3	3	3
3	3	3
195	195	195
7	7	7
29	29	29
38	38	38
94	102	110
34	37	40
31	34	34
56	59	60
106	106	106
7	7	7
6	6	6
161	161	161
153	153	153
145	145	145
191	191	191
144	147	150
152	152	154
145	145	145
153	153	153
0	0	0

mm 40 R  
mm 40 sts

mm 40 R  
border

cm sleeve width

cm sleeve length



### Note:

The test square for 40 stitches must result in at least 145 mm.

### Material:

450 g fairly fine Mohair/Acrylic (475 m length per 100 g, 149 yds per 1 oz).

### Stitch size:

Stocking stitch = 5½, 1 : 1 rib = 3¼.

### Pattern:

Front part, back and sleeves: stocking stitch.  
Collar: stocking stitch, tubular.  
Cuffs: 1 : 1 rib.

### Flashing figures:

- 1 Front and back part: contrast yarn, cast on for stocking stitch.  
Collar: contrast yarn, cast on for stocking stitch, tubular.  
Sleeves: tubular cast on for 1 : 1 rib.
- 2 Transfer all stitches to front bed for stocking stitch.
- 3 Divide work, continue to knit at right.
- 4 End of first shoulder, to knit second shoulder press key GO.
- 5 Front part, back and sleeves: cast off all remaining stitches.  
Collar: a few rows contrast yarn, release.

### To make up:

Block and press parts. Measure neck opening and knit collar to fit. Join shoulder, side and sleeve seams. St by st, backstitch collar first to outside, then to inside of neck opening, st by st, backstitching through the open loops and unravelling contrast yarn. Set in sleeves. Make hem to required length, unravel contrast yarn.

## Polo neck

103
158
162
128
98
7
63
0

mm 40 R  
mm 40 sts

cm neck opening

Front part

36	40	44
87	87	87
476	476	476
40	43	44
22	23	24
22	23	24
194	194	194
4	4	4
166	166	166
40	43	44
87	93	99
34	35	35
65	66	67
68	68	68
191	191	191
133	134	134
62	63	64
6	6	6
101	101	101
7	7	7
2	2	2
24	24	32
7	7	7
51	52	53
0	0	0



Back

36	40	44
87	87	87
220	220	220
80	86	90
38	42	44
38	42	44
194	194	194
4	4	4
38	38	38
80	86	90
87	93	99
34	35	35
65	66	67
101	101	101
7	7	7
2	2	2
24	24	32
7	7	7
51	52	53
0	0	0



Material:

fairly fine Mohair/Acrylic  
(475 m length per 100 g, 149 yds per 1 oz)  
140–160 g black, 90–110 g each red,  
brown, rust.

Stitch size:

Pin tuck pattern back = 5 1/4, front = 4,  
front band back = 4 3/4, front = 5.

Pattern:

Pin tuck pattern with DECO punchcard  
95 and COLOR.

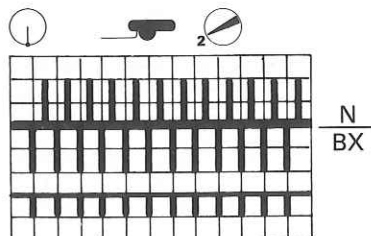

Colour sequence:

2 R black  
2 R red  
2 R brown  
2 R rust

Front bands

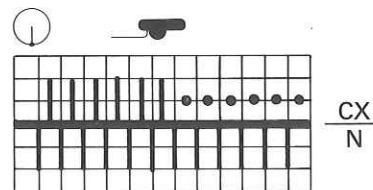

Flashing figures:

- 1 Tubular cast on with all needles.  
Front bands: cast on with contrast yarn.
- 2 Set lock for pattern.
- 5 Cast of all remaining stitches.  
Front bands: a few rows contrast yarn, release.

To make up:

Join shoulder seams. Measure for front bands and armhole bands, knit bands to required length acc. to diagram. Back-stitch the double-bed side of bands to front edges and armhole edges, then fold in half and sew to inside. Unravel contrast yarn and sew down the open loops. Join side seams.



## Front part

34	38	44	48
80	80	80	80
364	364	364	364
100	110	116	126
27	30	31	34
27	30	31	34
38	38	38	38
88	96	102	110
84	90	99	108
83	84	83	83
113	116	117	117
237	238	238	238
7	7	7	7
3	3	3	3
178	186	186	186
170	129	131	131
154	178	178	178
191	162	162	162
133	191	191	191
133	133	133	137
7	133	133	137
31	7	7	7
191	36	38	36
159	191	191	191
1	163	165	167
70	3	3	3
191	71	71	72
139	190	190	191
2	133	133	135
182	191	191	128
7	133	135	191
1	5	135	135
0	7	7	135
	3	2	7
	0	0	2
			0

mm 40 R  
mm 40 sts  
  
  
  
  
  
  
  
  
  
cm bust  
  
  
cm total length



## 1/2 Back

34	38	44	48
80	80	80	80
364	364	364	364
102	111	117	125
27	30	31	34
27	30	31	34
38	38	38	38
88	97	103	109
84	90	99	108
83	84	83	83
113	116	117	117
108	108	109	110
7	7	7	7
3	3	3	3
178	178	178	186
162	162	162	123
191	191	153	178
131	137	191	162
131	137	137	191
7	7	137	135
35	34	7	135
191	191	34	7
167	169	191	37
1	3	170	191
0	0	3	172
		0	3
			0

mm 40 R  
mm 40 sts  
  
  
  
  
  
  
  
  
  
cm bust  
  
  
cm total length



## Sleeve

34	38	44	48
80	80	80	80
108	108	108	108
130	140	144	148
35	38	39	40
35	38	39	40
38	38	38	38
150	164	168	172
40	44	45	46
40	40	40	40
58	59	60	60
109	111	111	111
7	7	7	7
3	3	3	3
185	185	185	185
129	131	131	131
177	185	185	185
186	129	129	129
129	177	177	177
191	161	161	161
134	145	162	145
19	191	191	191
188	135	135	136
129	21	21	23
178	188	188	188
0	129	129	129
	178	178	178
	0	0	0

mm 40 R  
mm 40 sts  
  
  
  
  
  
  
  
  
  
cm sleeve width  
  
  
cm sleeve length



## Front band

80
160
178
140
98
7
1
0

mm 40 R  
mm 40 sts  
  
  
cm band

## Collar

34	38	44	48
80	80	80	80
108	108	108	108
166	178	182	184
45	48	49	50
45	48	49	50
38	38	38	38
142	154	158	160
39	42	43	44
14	15	15	15
15	16	16	16
15	16	16	16
99	99	99	99
71	71	71	71
1	1	1	1
3	3	3	3
0	0	0	0

mm 40 R  
mm 40 sts  
  
  
  
  
  
  
  
  
  
cm neck opening

### Material:

fairly fine Mohair/Acrylic  
(475 m length per 100 g, 149 yds per 1 oz)  
550–700 g rust, 600–750 g black.

### Stitch size:

Fairisle back = 4½, front = 5½.  
Stocking stitch, half tubular = 5½.

### Pattern:

Reversible fairisle with DECO punch-card 63.

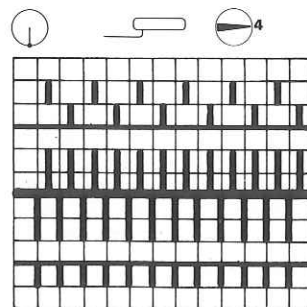

Front bands: half tubular, open at right.

### Flashing figures:

- 1 Tubular cast on in rust with 5 rows tubular.  
Front band: closed cast on for half tubular.
- 5 Cast off all remaining stitches.  
Collar and front band: a few rows contrast yarn, release.
- 7 Collar: knit tubular to the end.

### To make up:

Block and press parts. Join back seam and shoulders. Measure neck opening and knit collar to fit. St by st, backstitch collar to outside of neck opening, then to inside, st by st, backstitching through the open loops and unravelling contrast yarn. Measure along front edges and round collar edges and knit front band in two or three pieces depending on your test square. Join the pieces and backstitch to outer edge first, then to inside, st by st, backstitching through the open loops and unravelling contrast yarn. Join sleeve seams. Set in sleeves.

Front part

36	40	44	50
124	124	124	124
164	164	164	164
120	126	134	154
87	93	99	114
98	98	98	98
7	7	7	7
77	83	81	79
38	38	38	38
120	126	134	154
3	3	3	3
3	3	3	3
36	38	37	37
114	119	119	119
231	231	231	231
6	6	6	6
184	184	184	184
136	135	138	141
7	7	7	7
24	24	27	29
189	189	189	189
146	146	146	153
70	71	71	71
168	176	176	176
161	186	186	186
178	129	129	129
162	178	178	153
137	145	145	162
5	137	146	155
0	5	5	5
	0	0	0

mm 40 R  
mm 40 sts

cm hips

cm total length

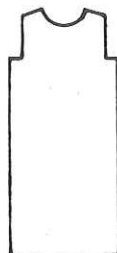

Back

36	40	44	50
124	124	124	124
164	164	164	164
120	126	134	154
87	93	99	114
98	98	98	98
7	7	7	7
77	83	81	79
38	38	38	38
120	126	134	154
3	3	3	3
3	3	3	3
36	38	37	37
114	119	119	119
103	103	103	103
6	6	6	6
184	184	184	184
133	133	136	138
7	7	7	7
24	24	27	29
189	189	189	189
149	151	151	158
0	0	0	0

mm 40 R  
mm 40 sts

cm hips

cm total length



Sleeve

36	40	44	50
124	124	124	124
164	164	164	164
96	100	102	108
39	41	42	44
39	41	42	44
38	38	38	38
96	100	102	108
39	41	42	44
39	41	42	44
45	47	47	47
56	58	59	59
99	99	99	99
71	71	71	71
1	1	1	1
6	6	6	6
0	0	0	0

mm 40 R  
mm 40 sts

cm sleeve length



Collar

103
158
162
128
98
7
63
0

mm 40 R  
mm 40 sts

cm neck opening

Material:

fairly fine Mohair/Acrylic (475 m length per 100 g, 149 yds per 1 oz) 410–450 g pale rust, 210–250 g dark rust.

Stitch size:

5 1/2.

Pattern:

Fairisle with DECO punchcard 89.

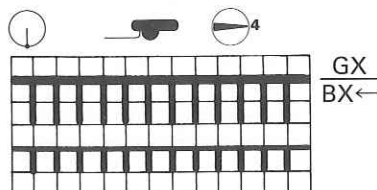

Sleeves: stocking stitch.  
Collar: stocking stitch, tubular.

Flashing figures:

- Single bed cast on with contrast yarn.  
Collar: closed cast on for tubular, with contrast yarn.
- Divide work, continue to knit at right.
- End of first shoulder, to knit second shoulder press key GO.
- Front and back part: cast off all remaining stitches.  
Sleeves and collar: a few rows contrast yarn, release.
- Sleeves: a few rows contrast yarn, release and return stitches to exactly half the number of needles, i.e. place 2 stitches on each needle. Continue to knit stocking stitch.

To make up:

Block and press parts. Join shoulder seams. Measure neck opening and knit collar to match. St by st, backstitch collar to outside of neck opening, then to inside, st by st, backstitching through the open loops and unravelling contrast yarn. Set in sleeves, st by st, backstitching through the open loops and unravelling contrast yarn. Fold cuffs in half to inside and sew in position. Join sleeve and side seams. Make hem.



## Front part

48	52	56
77	77	77
129	129	129
156	168	182
96	104	112
96	104	112
195	195	195
7	7	7
20	20	20
38	38	38
156	168	182
96	104	112
31	32	33
71	73	75
229	229	229
7	7	7
3	3	3
191	191	191
172	175	182
59	65	68
70	71	71
177	185	185
153	134	134
179	153	153
182	179	179
7	155	155
3	7	7
0	6	6
0	0	0

mm 40 R  
mm 40 sts

mm 40 R  
border

cm chest

cm total length

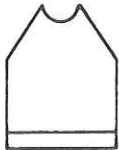

## Back

48	52	56
77	77	77
129	129	129
156	168	182
96	104	112
96	104	112
195	195	195
7	7	7
20	20	20
38	38	38
156	168	182
96	104	112
31	32	33
71	73	75
101	101	101
7	7	7
3	3	3
191	191	191
172	180	187
62	70	73
0	0	0

mm 40 R  
mm 40 sts

mm 40 R  
border

cm chest

cm total length



## Collar

103
158
162
64
98
7
24
0

mm 40 R  
mm 40 sts

cm neck opening

## Sleeve

(knit 2<sup>nd</sup> sleeve with reversed shapings)

48	52	56
77	77	77
129	129	129
82	88	94
26	28	30
26	28	30
195	195	195
7	7	7
20	20	20
38	38	38
126	126	132
40	40	42
32	32	34
62	64	66
71	71	71
7	7	7
3	3	3
191	191	191
175	177	180
60	59	62
187	190	190
136	135	135
69	69	69
7	7	7
3	3	3
191	191	191
177	177	180
63	65	68
0	0	0

mm 40 R  
mm 40 sts

mm 40 R  
border

cm sleeve width

cm sleeve length



## Material:

fairly fine Mohair/Acrylic  
(475 m length per 100 g, 149 yds per 1 oz)  
230–270 g black, 60–80 g each: pale rust  
and dark rust.

## Stitch size:

Pattern = 5½, 1:1 rib = 3½.

## Pattern:

single bed tuck stitch pattern.

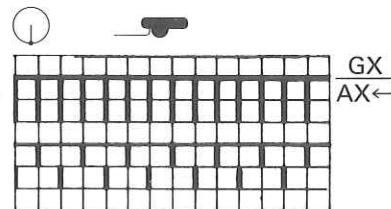

## Colour sequence:

2 R black  
2 R pale rust  
2 R black  
2 R dark rust

Waist and sleeve bands, polo neck  
collar: 1:1 rib.

## Flashing figures:

- 1 Tubular cast on for 1:1 rib.
- 2 Transfer all stitches to front for pattern.
- 3 Divide work, continue to knit at right.
- 4 End of first shoulder, to knit second shoulder press key GO.
- 5 Cast off all remaining stitches.  
Collar: a few rows contrast yarn, release.

## To make up:

Block and press parts. Sew sleeves between front and back parts with shorter raglan edge to the front. Measure neck opening and knit collar. St by st, backstitch collar to outside of neck opening, then to inside, st by st, backstitching through the open loops and unravelling contrast yarn. Join sleeve and side seams.

### Front part

38	42	46
50	50	50
160	160	160
126	136	146
50	54	58
50	54	58
195	195	195
7	7	7
17	17	17
38	38	38
126	136	146
90	96	102
28	28	28
61	62	63
237	236	236
7	7	7
9	9	9
162	186	186
154	129	129
164	178	178
191	162	162
128	158	158
7	7	7
7	61	67
53	191	191
191	149	151
146	9	9
9	71	72
71	184	184
184	130	130
128	178	178
153	167	154
162	2	175
182	7	3
7	26	7
28	0	23
0		0



### Back

38	42	46
50	50	50
160	160	160
110	120	130
44	48	52
44	48	52
195	195	195
7	7	7
17	17	17
38	38	38
110	120	130
90	96	102
28	28	28
61	62	63
234	235	235
7	7	7
9	9	9
154	162	170
164	154	154
158	146	146
7	158	158
59	7	7
191	61	67
146	191	191
9	150	153
69	9	9
184	68	68
131	184	184
161	136	139
179	164	164
4	4	4
0	0	0



### Sleeve

38	42	46
50	50	50
160	160	160
60	62	66
24	25	26
24	25	26
195	195	195
7	7	7
17	17	17
38	38	38
90	100	100
36	40	44
34	34	34
56	57	59
107	108	108
7	7	7
9	9	9
191	170	170
131	154	154
131	146	146
191	191	191
136	139	142
23	29	35
179	146	146
189	180	180
136	162	162
0	170	170
	0	0



### Collar

103
158
162
64
98
7
17
0

The 'long stitch' is knitted at the end of the pattern repeat.

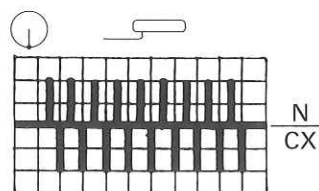

### Material:

medium Mohair/Acrylic (475 m length per 100 g, 149 yds per 1 oz), 30-40 g colour 6, 60-90 g each of colours 5, 4, 3, 1, 290-340 g colour 2 (colour 1 = lightest shade, colour 6 = darkest shade).

### Stitch size:

Fairisle back = 5, front = 5 1/2, 2:2 rib = 3 3/4.

### Pattern:

Fairisle 'long stitch' with DECO punch-card 75.

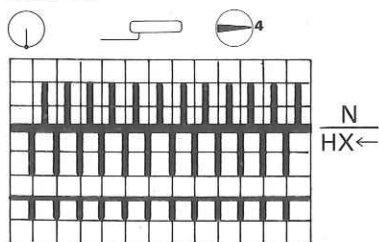

### Colour sequence:

16 × {	2 R col. 2	R 64
	2 R col. 1	
8 × {	2 R col. 2	R 96
	2 R col. 3	
8 × {	2 R col. 4	R 128
	2 R col. 3	
8 × {	2 R col. 4	R 160
	2 R col. 5	
16 × {	2 R col. 6	R 224
	2 R col. 5	
8 × {	2 R col. 4	R 256
	2 R col. 5	
8 × {	2 R col. 4	R 288
	2 R col. 3	
8 × {	2 R col. 2	R 320
	2 R col. 3	
16 × {	2 R col. 2	R 384 total
	2 R col. 1	

Borders and collar: 2:2 rib.

### Flashing figures:

- 1 Tubular cast on for 2:2 rib.
- 2 Bring empty needles into Working Position. Knit the first 2 rows with lock front and back CX. Then set lock for pattern.
- 3 Divide work, continue to knit at right.
- 4 End of first shoulder, to knit second shoulder press key GO.
- 5 Cast off all remaining stitches. Collar: a few rows with contrast yarn, release.

### To make up:

Block and press parts. Join shoulder, side and sleeve seams. Measure neck opening and knit collar. Sew collar together, and attach to outside of neck opening, st by st, backstitching through the open loops and unravelling contrast yarn. Set in sleeves.



## Front part

110	122	134	146	158
48	48	48	48	48
198	198	198	198	198
68	72	76	80	84
68	72	76	80	84
68	72	76	80	84
195	195	195	195	195
7	7	7	7	7
19	19	19	19	19
38	38	38	38	38
68	72	76	80	84
62	66	70	74	80
18	20	22	24	26
41	44	47	50	53
234	234	234	234	234
7	7	7	7	7
1	1	1	1	1
153	161	153	153	153
162	162	162	162	162
137	137	137	137	137
7	7	7	7	7
43	48	52	56	59
191	191	191	191	191
134	135	137	138	140
1	1	1	1	1
68	68	68	68	68
184	184	184	184	184
134	135	135	136	136
7	7	7	7	7
43	48	52	56	59
0	0	0	0	0

mm 40 R  
mm 40 sts

mm 40 R  
border

cm bust

cm total  
length



## Back

110	122	134	146	158
48	48	48	48	48
198	198	198	198	198
68	72	76	80	84
68	72	76	80	84
68	72	76	80	84
195	195	195	195	195
7	7	7	7	7
19	19	19	19	19
38	38	38	38	38
68	72	76	80	84
62	66	70	74	80
18	20	22	24	26
41	44	47	50	53
106	106	106	106	106
7	7	7	7	7
1	1	1	1	1
153	153	153	153	153
162	162	162	162	162
137	137	137	137	137
7	7	7	7	7
43	48	52	56	59
191	191	191	191	191
134	135	137	138	140
1	1	1	1	1
68	68	68	68	68
184	184	184	184	184
134	135	135	136	136
7	7	7	7	7
43	48	52	56	59
0	0	0	0	0

mm 40 R  
mm 40 sts

mm 40 R  
border

cm bust

cm total  
length

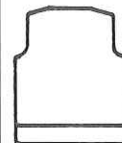

## Sleeve

110	122	134	146	158
48	48	48	48	48
198	198	198	198	198
36	38	40	42	44
36	38	40	42	44
36	38	40	42	44
195	195	195	195	195
7	7	7	7	7
15	15	15	15	15
38	38	38	38	38
52	54	56	58	60
26	27	28	29	30
24	26	28	30	32
41	44	47	50	53
103	103	103	103	103
7	7	7	7	7
1	1	1	1	1
145	145	145	145	145
191	191	191	191	191
137	137	138	138	139
33	37	41	46	49
145	145	145	145	145
0	0	0	0	0

mm 40 R  
mm 40 sts

mm 40 R  
border

cm sleeve  
width

cm sleeve  
length



## Collar

103
158
162
64
98
7
11
0

mm 40 R  
mm 40 sts

cm neck opening

## Material:

medium yarn (530 m length per 100 g, 166 yds per 1 oz), 240–320 g white, 120–160 g blue, 30–50 g red.

## Stitch size:

Pattern = 3<sup>3</sup>/<sub>4</sub>, 2:2 rib = 3.

## Pattern:

Fairisle with DECO punchcard 44.

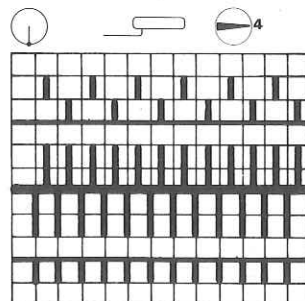

## Colour sequence:

Rows acc. to right-hand window of card reader.

Main colour white

0–16 red  
16–08 blue  
08–28 red  
28–20 blue

Borders, collar: 2:2 rib.

## Flashing figures:

- 1 Tubular cast on for 2:2 rib.
- 2 Bring empty needles into Working Position. Knit the first 2 rows with lock front and back CX. Then set lock for pattern.
- 3 Divide work, continue to knit at right.
- 4 End of first shoulder, to knit second shoulder press key GO.
- 5 Cast off all remaining stitches.  
Collar: a few rows contrast yarn, release.

## To make up:

Block and press parts. Join shoulder, side and sleeve seams. Measure neck opening (without measuring horizontal part at front). Knit collar. Sew collar to neck opening, st by st, backstitching through the open loops and unravelling contrast yarn. Cross collar edges and sew to horizontal part of neck opening. Join side and sleeve seams. Set in sleeves.

Front part

98	104	110	122	134	146	158	164
75	75	75	75	75	75	75	75
230	230	230	230	230	230	230	230
54	56	58	62	66	70	74	76
3	3	3	3	3	3	3	3
3	3	3	3	3	3	3	3
195	195	195	195	195	195	195	195
7	7	7	7	7	7	7	7
8	8	8	8	8	8	8	8
38	38	38	38	38	38	38	38
54	56	58	62	66	70	74	76
58	60	62	66	70	74	80	84
14	16	18	20	22	24	28	32
34	37	40	43	46	50	55	60
232	232	232	232	232	233	233	233
5	5	5	5	5	5	5	5
153	153	153	153	153	153	153	161
145	145	145	145	145	145	145	145
146	146	146	146	146	146	146	146
7	7	7	7	7	7	7	7
18	21	24	26	29	32	34	34
189	189	189	189	189	191	191	191
131	131	132	133	135	136	138	138
70	70	70	70	70	1	1	3
161	161	161	161	161	70	70	70
153	153	153	153	153	161	161	161
145	145	162	162	162	153	153	153
137	146	137	137	137	162	162	162
7	7	7	7	7	146	146	155
5	4	4	4	4	7	7	7
0	0	0	0	0	4	4	4
					0	0	0

mm 40 R  
mm 40 sts  
mm 40 R border  
cm bust  
cm total length



Back

98	104	110	122	134	146	158	164
75	75	75	75	75	75	75	75
230	230	230	230	230	230	230	230
54	56	58	62	66	70	74	76
3	3	3	3	3	3	3	3
3	3	3	3	3	3	3	3
195	195	195	195	195	195	195	195
7	7	7	7	7	7	7	7
8	8	8	8	8	8	8	8
38	38	38	38	38	38	38	38
54	56	58	62	66	70	74	76
58	60	62	66	70	74	80	84
14	16	18	20	22	24	28	32
34	37	40	43	46	50	55	60
104	104	104	104	104	105	105	105
5	5	5	5	5	5	5	5
153	153	153	153	153	153	153	161
145	145	145	145	145	145	145	145
146	146	146	146	146	146	146	146
7	7	7	7	7	7	7	7
17	18	21	24	26	29	31	31
189	189	189	189	189	191	191	191
131	131	132	133	135	136	138	138
0	0	0	0	0	1	1	3
					0	0	0

mm 40 R  
mm 40 sts  
mm 40 R border  
cm bust  
cm total length

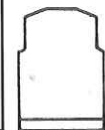

Collar

98	122	158
104	134	164
110	146	
103	103	103
158	158	158
162	162	162
64	64	64
98	98	98
7	7	7
22	28	34
0	0	0

mm 40 R  
mm 40 sts  
cm neck opening

Sleeve

98	104	110	122	134	146	158	164
75	75	75	75	75	75	75	75
230	230	230	230	230	230	230	230
28	30	32	32	34	36	38	40
16	17	18	19	20	21	22	23
16	17	18	19	20	21	22	23
195	195	195	195	195	195	195	195
7	7	7	7	7	7	7	7
8	8	8	8	8	8	8	8
38	38	38	38	38	38	38	38
40	42	44	46	48	48	50	52
23	24	25	26	27	28	29	30
20	22	24	26	28	30	34	38
34	37	40	43	46	49	54	59
101	101	101	101	101	101	101	101
5	5	5	5	5	5	5	5
145	145	145	145	145	145	145	153
191	191	191	191	191	191	191	191
134	135	138	136	137	136	137	137
11	14	16	19	21	24	26	29
0	0	0	0	0	0	0	0

mm 40 R  
mm 40 sts  
mm 40 R border  
cm sleeve width  
cm sleeve length



Material:

390-480 g medium yarn  
(460 m length per 100 g, 144 yds per 1 oz).

Stitch size:

Pattern back = 4, front = 5 1/2, 2 : 2 rib = 4.

Pattern: Racking pattern.

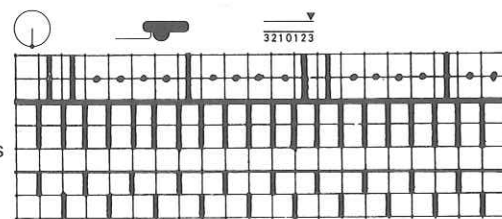

Borders, polo neck collar: 2 : 2 rib.

Flashing figures:

- 1 Tubular cast on for 2 : 2 rib.
- 2 Transfer stitches acc. to diagram.
- 3 Divide work, continue to knit at right.
- 4 End of first shoulder, to knit second shoulder press key GO.
- 5 Cast off all remaining stitches.

Collar: a few rows contrast yarn, release.

To make up:

Block and press parts. Join side, shoulder and sleeve seams. Measure neck opening and knit collar to fit. Close collar seam and attach to neck opening st by st, backstitching through the open loops and unravelling contrast yarn. Set in sleeves.

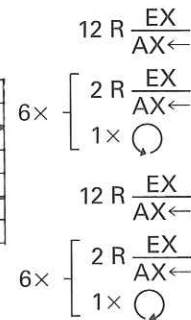



## Front part

110	122	134	146	152
52	52	52	52	52
416	416	416	416	416
38	42	44	46	48
68	72	76	80	84
68	72	76	80	84
195	195	195	195	195
7	7	7	7	7
18	18	18	18	18
38	38	38	38	38
38	42	44	46	48
60	64	68	73	76
20	22	24	25	27
45	48	51	55	58
232	232	232	233	233
7	7	7	7	7
1	1	1	1	1
184	184	184	184	184
131	131	131	131	131
7	7	7	7	7
54	58	63	70	74
189	189	189	191	191
139	141	144	145	146
69	69	69	1	1
153	153	153	69	70
162	179	179	153	153
155	155	146	179	188
7	7	7	155	129
6	7	10	7	146
0	0	0	13	7
			0	15
				0

mm 40 R  
mm 40 sts  
mm 40 R  
border  
cm chest  
cm total length



## Back

110	122	134	146	152
52	52	52	52	52
160	160	160	160	160
86	90	96	100	106
68	72	76	80	84
68	72	76	80	84
195	195	195	195	195
7	7	7	7	7
18	18	18	18	18
38	38	38	38	38
86	90	96	100	106
60	64	68	73	76
20	22	24	25	27
45	48	51	55	58
104	104	104	105	105
7	7	7	7	7
1	1	1	1	1
184	184	184	184	184
131	131	131	131	131
7	7	7	7	7
54	58	63	70	74
189	189	189	191	191
139	141	144	145	146
0	0	0	1	1
			0	0

mm 40 R  
mm 40 sts  
mm 40 R  
border  
cm chest  
cm total length

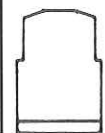

## Sleeve

110	122	134	146	152
52	52	52	52	52
160	160	160	160	160
46	48	50	52	54
18	19	20	21	22
18	19	20	21	22
195	195	195	195	195
7	7	7	7	7
14	14	14	14	14
38	38	38	38	38
80	86	90	100	106
32	34	36	40	42
32	34	36	40	42
30	32	34	36	38
39	41	43	45	47
98	98	98	98	98
7	7	7	7	7
8	8	8	8	8
0	0	0	0	0

mm 40 R  
mm 40 sts  
mm 40 R  
border  
cm sleeve length

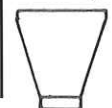

## Neckband

103
158
162
64
98
7
9
0

mm 40 R  
mm 40 sts  
cm neck opening

## Front band

100
259
3
16
3
3
98
6
8
38
25
3
3
42
47
97
3
0

mm 40 R  
cm total length

## Material:

fairly fine wool (530 m length per 100 g, 166 yds per 1 oz) 420–510 g white, 40 g each: red and blue.

## Stitch size:

Fairisle back = 3<sup>1</sup>/<sub>2</sub>, front = 3<sup>3</sup>/<sub>4</sub>, 2:2 rib = 3, K/K = 3.

## Pattern:

Fairisle with DECO punchcard 46.

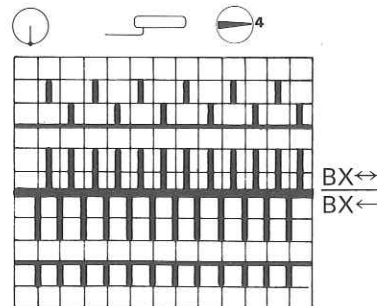

## Coloured trimming:

Following the armhole shaping, use punchcard 46b from row 72–08 with trimming colour red and from row 08–40 with trimming colour blue. On the sleeve, 36 rows before the end, knit only red trimming.

Bands: 2:2 rib.  
Front bands: K/K.

## Flashing figures:

- 1 Tubular cast on for 2:2 rib.  
Front bands: Tubular cast on with all needles.
- 2 Bring all needles into Working Position. Knit the first 2 rows with lock front and back CX. Then set lock for pattern.
- 5 Cast off all remaining stitches.  
Collar: a few rows contrast yarn, release.

## Note: Front bands:

the message "+ 1" means: work a buttonhole here over 6 needles.

## To make up:

Block and press parts. Join shoulder seams. Measure neck opening and knit neckband. Sew neckband to outside of neck opening, st by st, backstitching through the open loops and unravelling contrast yarn. Fold in half to inside and catch down. Measure along front edges and knit two front bands, one of which with buttonholes. Sew front bands in position. Set in sleeves. Join side and sleeve seams.

### Front part

92	98	110	122	134	146	158	164
60	60	60	60	60	60	60	60
155	155	155	155	155	155	155	155
86	88	94	100	104	110	114	120
66	68	72	76	80	84	88	92
66	68	72	76	80	84	88	92
195	195	195	195	195	195	195	195
7	7	7	7	7	7	7	7
11	11	11	11	11	11	11	11
38	38	38	38	38	38	38	38
86	88	94	100	104	110	114	120
66	68	72	76	80	84	88	92
17	18	20	22	24	26	28	30
38	40	43	46	49	52	55	58
228	228	228	228	228	228	228	228
6	6	6	6	6	6	6	6
191	191	191	191	191	191	191	191
149	150	152	155	157	158	160	163
43	46	50	53	56	60	63	66
67	67	67	67	67	67	67	67
191	191	191	191	191	191	191	191
134	134	135	135	135	137	137	137
40	43	47	50	53	57	60	63
0	0	0	0	0	0	0	0

mm 40 R  
mm 40 sts

mm 40 R  
border

cm chest

cm  
total  
length



### Back

92	98	110	122	134	146	158	164
60	60	60	60	60	60	60	60
155	155	155	155	155	155	155	155
86	88	94	100	104	110	114	120
66	68	72	76	80	84	88	92
66	68	72	76	80	84	88	92
195	195	195	195	195	195	195	195
7	7	7	7	7	7	7	7
11	11	11	11	11	11	11	11
38	38	38	38	38	38	38	38
86	88	94	100	104	110	114	120
66	68	72	76	80	84	88	92
17	18	20	22	24	26	28	30
38	40	43	46	49	52	55	58
100	100	100	100	100	100	100	100
6	6	6	6	6	6	6	6
191	191	191	191	191	191	191	191
152	153	155	158	160	162	164	167
46	50	53	56	60	63	66	70
0	0	0	0	0	0	0	0

mm 40 R  
mm 40 sts

mm 40 R  
border

cm chest

cm total length

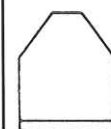

### Neckband

103
158
162
64
97
6
0

mm 40 R  
mm 40 sts

cm neck opening

**Material:** 170–340 g fairly fine yarn (530 m length per 100 g, 166 yds per 1 oz) a remainder red.

**Stitch size:** Pattern: front = 5¼, back = 3¾, 2:2 rib = 3.

**Pattern:** Raised pattern with transfer lock U70 or U80.

### Sleeve

92	98	110	122	134	146	158	164
60	60	60	60	60	60	60	60
155	155	155	155	155	155	155	155
46	50	52	54	58	60	62	64
18	19	20	21	22	23	24	25
18	19	20	21	22	23	24	25
195	195	195	195	195	195	195	195
7	7	7	7	7	7	7	7
11	11	11	11	11	11	11	11
38	38	38	38	38	38	38	38
64	68	72	78	84	88	94	100
25	26	28	30	32	34	36	38
18	19	21	23	25	27	31	35
32	34	37	40	43	46	51	56
68	68	68	68	68	68	68	68
6	6	6	6	6	6	6	6
191	191	191	191	191	191	191	191
147	149	149	152	155	156	159	162
46	50	53	56	60	63	66	70
70	70	70	70	70	70	70	70
6	6	6	6	6	6	6	6
191	191	191	191	191	191	191	191
147	149	149	152	155	156	159	162
43	46	50	53	56	60	63	66
187	188	187	187	188	187	187	188
133	133	135	135	135	137	137	137
0	0	0	0	0	0	0	0

mm 40 R  
mm 40 sts

mm 40 R  
border

cm  
sleeve  
width

cm  
sleeve  
length

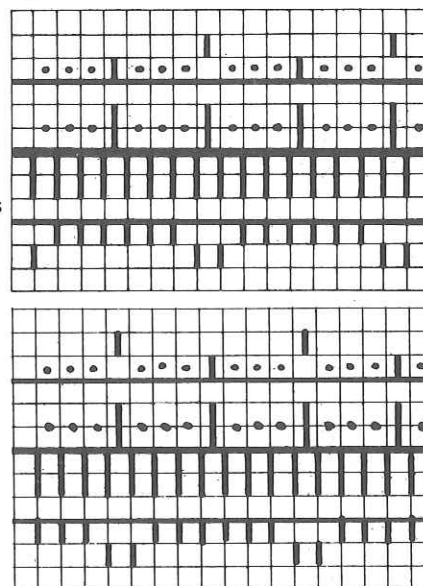
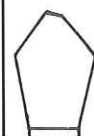

1 R BX←  
AX

6 R BX  
AX

1 R BX  
N

1 R BX←  
AX

6 R BX  
AX

1 R BX  
N

All bands: 2:2 rib. 6<sup>th</sup> to 2<sup>nd</sup> row before end knit in red.

**Flashing 1** Tubular cast on for 2:2 rib.

**figures:** 2 Transfer stitches for pattern acc. to diagram.

3 Divide work, continue to knit at right.

4 End of first shoulder, to knit second shoulder press key GO.

5 Front part, back and sleeves: cast off all remaining stitches.

Neckband: a few rows contrast yarn, release.

### To make up:

Pin parts out to size and leave to dry under a damp cloth. Sew sleeves between front and back parts, with shorter part to the front. Measure neck opening and knit neckband. Sew neckband to outside of neck opening, st by st, back-stitching through the open loops and unravelling contrast yarn. Mitre point. Join sleeve and side seams.



## Front part

110	122	134	146	158
108	108	108	108	108
416	416	416	416	416
40	42	46	48	50
68	72	76	80	84
68	72	76	80	84
195	195	195	195	195
7	7	7	7	7
6	6	6	6	6
38	38	38	38	38
40	42	46	48	50
62	66	70	74	80
16	18	20	21	22
40	42	46	50	52
233	233	233	233	233
7	7	7	7	7
2	2	2	2	2
178	178	178	178	178
145	145	145	145	145
146	155	155	146	146
7	7	7	7	7
12	12	14	19	21
187	187	189	189	189
133	135	137	139	141
67	67	67	67	67
191	191	191	191	191
138	138	139	139	140
23	24	28	30	30
0	0	0	0	0



## Back

110	122	134	146	158
108	108	108	108	108
160	160	160	160	160
84	92	96	100	108
68	72	76	80	84
68	72	76	80	84
195	195	195	195	195
7	7	7	7	7
6	6	6	6	6
38	38	38	38	38
84	92	96	100	108
62	66	70	74	80
16	18	20	21	22
40	42	46	50	52
105	105	105	105	106
7	7	7	7	7
2	2	2	2	2
153	178	178	153	161
164	145	145	164	153
146	146	146	146	145
7	7	7	7	146
10	13	15	17	7
187	187	189	189	21
133	135	137	139	189
0	0	0	0	141
				0

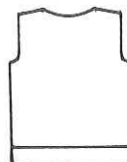

## Sleeve

110	122	134	146	158
108	108	108	108	108
160	160	160	160	160
48	52	54	56	58
19	20	21	22	23
19	20	21	22	23
195	195	195	195	195
7	7	7	7	7
1	1	1	1	1
38	38	38	38	38
66	70	74	76	78
27	28	29	30	31
24	26	28	30	34
35	38	41	44	49
105	105	104	104	104
5	5	5	5	5
153	153	153	153	153
189	188	179	162	145
131	129	191	191	191
191	191	134	136	139
128	131	134	136	141
128	131	145	145	145
145	145	153	153	153
153	153	0	0	0
0	0			



## Front band

100	
259	
	mm 40 R
3	
14	
3	
3	
98	
5	
8	
38	
23	
3	
3	
30	
32	
	cm buttonhole
38	
19	
3	
3	
75	
107	
	cm total length
0	

## Material:

fairly fine wool (530 m length per 100 g, 166 yds per 1 oz), 210–420 g red, 110–220 g white, 70–140 g blue, 5 buttons.

## Stitch size:

Fairisle = 3½, 2:2 rib = 3, K/K = 2¾.

## Pattern:

Fairisle with DECO punchcard 31.

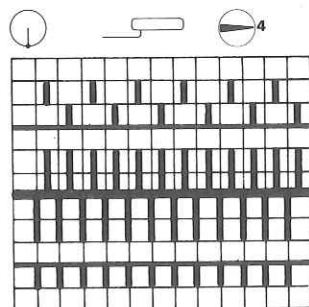

## Colour sequence:

Begin with 24 rows red in fairisle stitch, then in blue/white with DECO punchcard 31. However, each time a figure on black background appears in the right-hand window of the card reader, set DECO to zero and knit 24 rows red in fairisle stitch.

Welt: 2:2 rib.  
Front band: K/K.

## Flashing figures:

- 1 Tubular cast on for 2:2 rib.  
Front band: tubular cast on with all needles.
- 2 Bring empty needles into Working Position. Knit the first 2 rows with lock front and back CX. Then set lock for pattern.
- 5 Cast off all remaining stitches.  
Front band: a few rows contrast yarn, release.

## Note: Front band:

the message "+ 1" means: work a buttonhole here over 6 stitches.

## To make up:

Block and press parts. Join shoulder, side and sleeve seams. Measure jacket front edge to where the last buttonhole is required as well as measuring the total length. Insert both measurements and knit front band. Sew front band in position with mattress stitch, unravel contrast yarn and neaten loose stitches. Set in sleeves. Attach buttons.

Trousers (2<sup>nd</sup> part knitted with reversed shapings)

116	134	146	158
38	38	38	38
154	154	154	154
122	132	140	148
47	51	54	57
47	51	54	57
38	38	38	38
122	132	140	148
3	3	3	3
3	3	3	3
47	54	62	67
69	80	90	97
72	72	73	74
144	144	144	144
175	175	175	175
5	5	5	5
150	150	167	167
191	141	5	5
129	191	142	151
89	129	191	5
3	106	130	191
71	72	110	129
144	144	73	115
183	183	144	73
5	5	183	144
150	167	5	183
142	5	167	5
7	142	5	167
85	7	151	5
99	100	5	151
71	99	7	5
1	71	104	7
13	1	99	115
0	13	71	99
	0	1	71
		13	1
		0	13
			0

mm 40 R  
mm 40 sts

cm total length

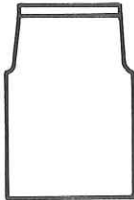

**Material:**

270–540 g fairly fine wool  
(530 m length per 100 g, 166 yds per 1 oz).

**Stitch size:**

Pattern = 3½, stocking stitch = 4½.

**Pattern:**

Single bed tuck stitch pattern.

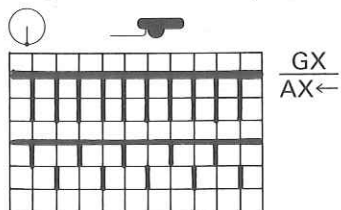

Waistband: stocking stitch.

**Flashing figures:**

- 1 Tubular cast on for 1 : 1 rib. Knit 5 rows then transfer all stitches to front bed for tuck stitch pattern.
- 5 A few rows contrast yarn, release.
- 7 Continue to knit stocking stitch.

**To make up:**

Block and press parts. Join leg and seat seams. Fold waistband in half to inside and sew in position, unravel contrast yarn. Insert waist elastic. Adjust legs to required length.



## Front part

3	6	9	12	months
70	70	70	70	
140	140	140	140	
				mm 40 R
				mm 40 sts
58	68	72	78	
20	24	25	27	
20	24	25	27	
194	194	194	194	
70	70	70	70	
5	5	5	5	
226	226	226	226	
7	7	7	7	
60	62	66	69	
68	68	68	68	
184	184	184	184	
140	142	143	144	
7	7	7	7	
3	3	6	6	
0	0	0	0	

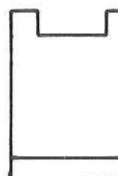

## Back

(2<sup>nd</sup> part knitted with reversed shapings)

3	6	9	12	months
70	70	70	70	
396	396	396	396	
				mm 40 R
				mm 40 sts
42	54	56	62	
15	19	20	22	
15	19	20	22	
194	194	194	194	
70	70	70	70	
5	5	5	5	
226	226	226	226	
7	7	7	7	
60	62	66	69	
68	68	68	68	
184	184	184	184	
152	162	163	167	
7	7	7	7	
3	3	6	6	
0	0	0	0	

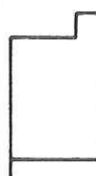

## Sleeve

3	6	9	12	months
70	70	70	70	
140	140	140	140	
				mm 40 R
				mm 40 sts
54	56	59	62	
19	20	21	22	
19	20	21	22	
194	194	194	194	
70	70	70	70	
5	5	5	5	
98	98	98	98	
7	7	7	7	
23	26	29	32	
0	0	0	0	



## Neckband

103	
158	
	mm 40 R
	mm 40 sts
162	
64	
	cm neck opening
97	
4	
0	

## Material:

Baby wool  
(405 m length per 100 g, 127 yds per 1 oz)  
40–60 g green, 30–50 g pale green.

## Stitch size:

Tuck stitch = 5, 1:1 rib = 2<sup>3</sup>/<sub>4</sub>.

## Pattern:

2-coloured tuck stitch pattern with DECO punchcard 39.

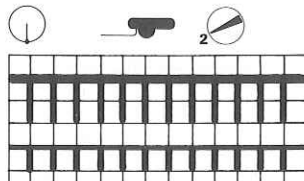

All bands: 1:1 rib.

GX  
AX←  
2 R  
pale green  
2 R  
green

## Flashing figures:

- 1 Tubular cast on for 1:1 rib.
- 2 Transfer all stitches to front bed for pattern.
- 3 Divide work, continue to knit at right.
- 4 End of first shoulder, a few rows with contrast yarn, release. To knit second shoulder, press key GO.
- 5 A few rows contrast yarn, release.

## To make up:

Block and press parts. Join shoulder seams with graft stitch. Sew sleeves in position, st by st, backstitching through the open loops and unravelling contrast yarn. Measure neck opening and knit neckband. St by st, backstitching through the open loops and unravelling contrast yarn, sew neckband in position. Join side and sleeve seams. Attach hook and button.

## Baby's pants

3	6	9	12	months
70	70	70	70	
140	140	140	140	
				mm 40 R
				mm 40 sts
72	75	78	83	
25	26	27	29	
25	26	27	29	
195	195	195	195	
70	70	70	70	
7	7	7	7	
4	4	4	4	
104	104	104	104	
7	7	7	7	
32	35	38	41	
168	168	168	168	
7	7	7	7	
128	128	128	128	
64	64	64	64	
1	1	1	1	
4	4	4	4	
0	0	0	0	

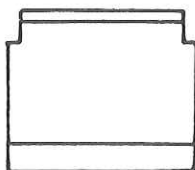
**Material:**

Baby wool  
(405 m length per 100 g, 127 yds per 1 oz)  
35–65 g green, 25–45 g pale green.

**Stitch size:**

Stocking stitch = 5, 1:1 rib = 2<sup>3</sup>/<sub>4</sub>.

**Pattern:**

Stocking stitch with stripes:  
2 R green, 2 R pale green.

Bands: 1:1 rib.

**Flashing figures:**

- 1 Tubular cast on for 1:1 rib.
- 2 Transfer all stitches to front bed for stocking stitch.
- 5 Loosely cast off all stitches.
- 7 Transfer stitches for 1:1 rib, put empty needles out of Working Position.

**To make up:**

Block and press parts. Join the two halves with mattress stitch. Join seat seam. Fold waistband in half to inside and sew in position. Insert waist elastic.



## Front / Back

3	6	9	12	months
97	97	97	97	
125	125	125	125	
				mm 40 R
				mm 40 sts
75	80	82	86	
24	25	26	28	
24	25	26	28	
195	195	195	195	
97	97	97	97	
7	7	7	7	
3	3	3	3	
101	101	101	101	
7	7	7	7	
32	36	39	41	
64	64	64	64	
1	1	1	1	
5	5	5	5	
0	0	0	0	



## Sleeve

3	6	9	12	months
97	97	97	97	
125	125	125	125	
				mm 40 R
				mm 40 sts
40	46	50	53	
13	15	16	17	
13	15	16	17	
195	195	195	195	
97	97	97	97	
7	7	7	7	
3	3	3	3	
100	100	100	100	
63	63	63	63	
128	128	128	128	
144	148	153	157	
4	4	4	4	
0	0	0	0	



### Material:

Baby wool  
(400 m length per 100 g, 125 yds per 1 oz)  
70–100 g white, a remainder green.

### Stitch size:

Stocking stitch = 5, 1:1 rib = 2¾.

### Pattern:

Stocking stitch.  
All bands: 1:1 rib.

### Flashing figures:

- 1 Tubular cast on for 1:1 rib.
- 2 Transfer all stitches to front bed for stocking stitch.
- 5 Front and back part: cast off loosely. Sleeves: a few rows contrast yarn, release.
- 7 Transfer stitches for 1:1 rib, put empty needles out of Working Position.

### To make up:

Block and press parts. Pin 1:1 rib neckbands one on top of the other. Attach sleeves, st by st, backstitching through the open loops and unravelling contrast yarn. Join sleeve and side seams. Attach 2 press studs if required on either side of neck opening to hold bands in position.

Leg

3	6	9	12	months
97	97	97	97	
125	125	125	125	
				mm 40 R
				mm 40 sts
82	86	88	94	
26	27	28	30	
26	27	28	30	
195	195	195	195	
97	97	97	97	
7	7	7	7	
3	3	3	3	
101	101	101	101	
36	36	36	36	
7	7	7	7	
24	29	32	37	
190	190	190	190	
130	130	130	130	
0	0	0	0	



Top

3	6	9	12	months
97	97	97	97	
125	125	125	125	
				mm 40 R
				mm 40 sts
144	152	156	168	
47	48	50	54	
47	48	50	54	
107	107	107	107	
7	7	7	7	
28	33	36	41	
64	64	64	64	
1	1	1	1	
7	7	7	7	
3	3	3	3	
184	184	184	184	
161	163	164	171	
191	191	191	191	
129	129	129	129	
131	131	131	131	
0	0	0	0	



Material:

Baby wool  
(400 m length per 100 g, 125 yds per 1 oz)  
80–110 g green, 60–80 g white.

Stitch size:

Tuck stitch = 4, 1 : 1 rib = 2<sup>3</sup>/<sub>4</sub>.

Pattern:

Double bed tuck stitch pattern.

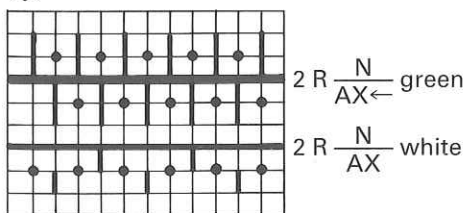

All bands and straps: 1 : 1 rib.

Flashing figures:

- 1 Tubular cast on for 1 : 1 rib.  
Note: Cast on at left of centre of bed for second leg.
- 2 Set lock for pattern.
- 5 First leg: a few rows contrast yarn, release.  
Second leg: return stitches of first leg to needles of machine adjoining second leg.  
Enter programme for top part and continue to knit.  
Top part: cast off loosely.
- 7 Set lock for 1 : 1 rib.

To make up:

Join leg, seat and back seams. Knit straps to required length in 1 : 1 rib with 11 stitches at front and 10 stitches at back. Attach to back part. Sew buttons to front part and attach loops to match.



## Front part

6	12	18	months
96	96	96	
154	154	154	
			mm 40 R 1:1 rib
			mm 40 sts 1:1 rib
28	32	34	
3	3	3	
3	3	3	
65	65	65	
3	3	3	
70	70	70	
71	71	71	
65	65	65	
5	5	5	
24	24	24	
2	2	2	
152	152	152	
195	195	195	
			mm 40 R stitch pattern
7	7	7	
40	46	50	
68	68	68	
7	7	7	
17	20	22	
186	186	186	
137	141	143	
70	70	70	
7	7	7	
11	14	16	
161	161	161	
189	189	189	
129	129	129	
2	2	2	
0	0	0	



## Back

6	12	18	months
96	96	96	
154	154	154	
			mm 40 R 1:1 rib
			mm 40 sts 1:1 rib
28	32	34	
3	3	3	
3	3	3	
70	70	70	
6	6	6	
6	6	6	
24	24	24	
120	120	120	
128	128	128	
149	153	155	
67	67	67	
71	71	71	
65	65	65	
5	5	5	
65	65	65	
2	2	2	
70	70	70	
6	6	6	
70	70	70	
65	65	65	
24	24	24	
65	65	65	
2	2	2	
195	195	195	
			mm 40 R stitch pattern
7	7	7	
43	49	53	
228	228	228	
7	7	7	
17	20	22	
186	186	186	
137	141	143	
68	68	68	
169	169	169	
186	187	187	
128	131	131	
1	1	1	
0	0	0	



## Front band

90	
259	
	mm 40 R
3	
4	
3	
3	
99	
7	
1	
8	
38	
26	
3	
3	
27	
30	
	cm length band
97	
2	
0	

## Neckband Sleeve band

103	
158	
	mm 40 R
	mm 40 sts
162	
64	
	cm neck armhole
96	
3	
0	

## Material:

Baby wool  
(400 m length per 100 g, 125 yds per 1 oz)  
120–150 g green, 10–20 g white, 10–20 g pink.

## Stitch size:

1:1 rib = 3½, garter stitch = 6.

## Pattern:

Yoke, legs and all bands: 1:1 rib.  
Trousers part: garter stitch with U80,  
changing colour every alternate row.

## Flashing figures:

- 1 Tubular cast on for 1:1 rib.
- 2 Transfer from garter stitch to 1:1 rib. Put empty needles out of Working Position.
- 3 Divide work, continue to knit at right.
- 4 End of first shoulder, to knit second shoulder press key GO.
- 5 A few rows with contrast yarn, release.
- 6 Place stitches of first leg on to deckercomb. Cast on for second leg on left side of bed.
- 7 Transfer all stitches for garter stitch.
- 8 Return stitches of first leg to needles of machine adjoining second leg and continue to knit with all needles.

## Note:

When knitting the front band, the message "+ 1" means: transfer centre stitch to adjoining needle to make buttonhole.

## To make up:

Block and press parts very lightly. Graft together shoulders, unravel contrast yarn. Join side seam as far as yoke. Measure neck and armhole openings and knit bands accordingly. Sew bands in position on the outside, st by st, backstitching through the open loops and unravelling contrast yarn. Measure front edge for front bands, knit one with and one without buttonholes. Sew front bands in position with mattress stitch. Join seat seam. Attach buttons.

## Front part

1	3	6	9	12	16	months
100	100	100	100	100	100	
132	132	132	132	132	132	
						mm 40 R
						mm 40 sts
104	108	116	120	128	132	
34	36	38	40	42	43	
34	36	38	40	42	43	
101	101	101	101	101	101	
7	7	7	7	7	7	
29	33	41	47	53	59	
248	248	248	248	248	248	
128	128	128	128	128	128	
173	175	179	181	185	187	
228	228	228	228	228	228	
7	7	7	7	7	7	
11	13	13	15	15	17	
188	188	188	188	188	188	
135	136	136	137	139	139	
67	67	67	67	67	67	
184	184	184	184	184	184	
133	133	135	135	135	136	
5	5	5	5	5	5	
0	0	0	0	0	0	

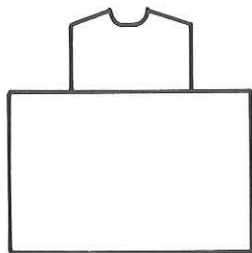

## Back

1	3	6	9	12	16	months
100	100	100	100	100	100	
388	388	388	388	388	388	
						mm 40 R
						mm 40 sts
52	54	58	60	64	66	
17	18	19	20	21	22	
17	18	19	20	21	22	
101	101	101	101	101	101	
7	7	7	7	7	7	
29	33	41	47	53	59	
248	248	248	248	248	248	
128	128	128	128	128	128	
147	148	150	151	153	154	
228	228	228	228	228	228	
7	7	7	7	7	7	
11	13	13	15	15	17	
188	188	188	188	188	188	
135	136	136	137	139	139	
67	67	67	67	67	67	
184	184	184	184	184	184	
133	133	135	135	135	136	
2	2	2	2	2	2	
0	0	0	0	0	0	

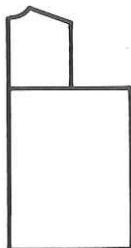

## Sleeve

1	3	6	9	12	16	months
100	100	100	100	100	100	
132	132	132	132	132	132	
						mm 40 R
						mm 40 sts
54	58	60	64	68	72	
18	20	20	22	22	24	
18	20	20	22	22	24	
194	194	194	194	194	194	
100	100	100	100	100	100	
5	5	5	5	5	5	
98	98	98	98	98	98	
7	7	7	7	7	7	
22	25	29	33	35	37	
0	0	0	0	0	0	

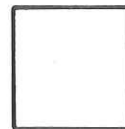

## Material:

Baby wool  
(400 m length per 100 g, 125 yds per 1 oz)  
60–80 g pink, 30–40 g dark pink,  
30–40 g white.

## Stitch size:

5

## Pattern:

2-coloured tuck stitch pattern with  
DECO punchcard 30.

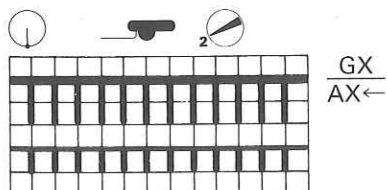

## Colour sequence:

Skirt: 2 R pink  
2 R dark pink  
Bodice: 2 R white  
2 R pink

Cuffs: stocking stitch, tubular

## Flashing figures:

- 1 Front and back part: tubular cast on for 1 : 1 rib, then transfer all stitches to front bed for pattern.  
Sleeves: closed cast on for tubular.
- 2 Transfer all stitches to front bed for pattern.
- 3 Divide work, continue to knit at right.
- 4 End of first shoulder, to knit second shoulder press key GO.
- 5 Front part and back: cast off all remaining stitches.  
Sleeves: a few rows contrast yarn, release.
- 6 Press key STOP, then knit a few rows with contrast yarn, release.  
Return stitches of skirt to needles of machine and decrease indicated number of stitches by placing 2 stitches on to each needle.  
To continue knitting, press key GO.

## To make up:

Block and press parts. Graft together shoulders, unravel contrast yarn. Attach sleeves, st by st, backstitching through the open loops and unravelling contrast yarn. Join sleeve and side seams. Join part of back seam or leave completely open as desired. Attach hooks and buttons.





Front part

6 months	9 months	86	92	104
96	96	96	96	96
130	130	130	130	140
144	156	168	178	176
44	48	52	56	58
44	48	52	56	58
38	38	38	38	38
144	156	168	178	176
44	48	52	56	58
44	48	52	56	58
19	22	25	27	29
30	35	39	43	47
231	233	233	233	233
248	248	248	248	248
128	128	128	128	128
193	199	205	210	209
6	7	7	7	7
48	1	3	6	7
7	56	56	56	56
10	129	131	133	134
68	7	7	7	7
184	12	12	14	16
136	68	68	68	68
7	184	184	184	184
1	136	136	138	138
0	7	7	7	7
	1	3	3	4
	0	0	0	0

mm 40 R  
mm 40 sts

cm total length

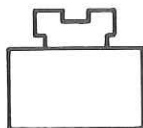

Back

6 months	9 months	86	92	104
96	96	96	96	96
130	130	130	130	140
144	156	168	178	176
44	48	52	56	58
44	48	52	56	58
38	38	38	38	38
144	156	168	178	176
44	48	52	56	58
44	48	52	56	58
19	22	25	27	29
30	35	39	43	47
231	233	233	233	233
248	248	248	248	248
128	128	128	128	128
193	199	205	210	209
6	7	7	7	7
48	1	3	6	7
7	56	56	56	56
10	129	131	133	134
67	7	7	7	7
184	12	12	14	16
136	67	67	67	67
4	184	184	184	184
0	136	136	138	138
	4	6	6	6
	0	0	0	0

mm 40 R  
mm 40 sts

cm total length

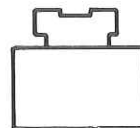

Material:

200–300 g medium cotton yarn (420 m length per 100 g, 132 yds per 1 oz).

Stitch size:

Lace pattern = 4<sup>1</sup>/<sub>4</sub>, stocking stitch = 5<sup>1</sup>/<sub>2</sub>.

Pattern:

Skirt: lace pattern with U70 or U80 and DECO punchcard 70.

Bodice: stocking stitch.

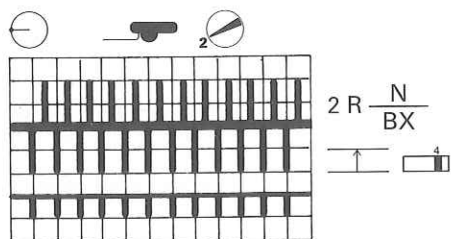

Note:

for size 104 the test square for 40 sts must equal at least 140 mm.

Flashing figures:

- 1 Tubular cast on for 1 : 1 rib, then transfer all stitches to back bed for pattern.
- 3 Divide work, continue to knit at right.
- 4 End of first shoulder, knit a few rows with contrast yarn, release. To knit second shoulder, press key GO.
- 5 A few rows contrast yarn, release.
- 6 Press key STOP, knit a few rows with contrast yarn, release. Return stitches of skirt to needles of machine and decrease stitches as indicated by placing 2 stitches on to each needle. To continue knitting, press key GO.

Should the measurement of the test square for the bodice be very different, press key E to recall the programme once more. Now replace the third and fourth figure with the figures of the measurements of the new test square.

To make up:

Block and press parts. Graft together shoulder seam, unravel contrast yarn. Join side seams. Crochet round neck and armhole openings.



MADAG Maschinen- und Apparatebau Dietikon AG  
CH-8953 DIETIKON/Schweiz-Suisse-Suiza-Switzerland

33.205.73/6 englisch