

The background of the cover is a light purple color. It features a repeating pattern of white, diagonal, brush-stroke-like streaks. Each streak is positioned above a small, solid red circular dot. The streaks and dots are arranged in a grid-like fashion, with the text centered in the middle of the page.

INSTRUCTION BOOK

CHUNKY ELECTRONIC KNITTING MACHINE

SK 890

PRECAUTION

This machine and the Pattern Controller must be kept away from the following places since electronic components are vulnerable to those conditions.

1. Direct and strong sun light.
2. Near to heater, or a place of excessively high temperature.
3. Excessively humid or dusty.

CONTENTS

	page
TO USE THE MACHINE	
MACHINE AND ACCESSORIES	2
SETTING UP THE MACHINE	5
NAMES AND FUNCTIONS OF EACH PART	7
Needle Positions	7
Cam Lever	8
Stitch Dial	8
Side Levers	8
Russel Levers	8
Release Lever	9
Tuck Brushes	9
Weaving Knobs	9
Row Counter and Feeding Trippers	9
YARN PREPARATION	10
THREADING THE YARN	11
YARN AND STITCH DIAL	12
CAST-ON AND KNITTING	13
Cast-on (1)	13
Cast-on (2)	15
Knitting Stripe Pattern	17
Moving the Carriage without Knitting	19
Removing the Knitting	19
TO KNIT PATTERNS USING THE PATTERN CONTROLLER, EC1	20
(See page 20 for the contents of this section.)	
HELPFUL HINTS	45
(See page 45 for the contents of this section.)	
MAINTAINING THE MACHINE	55
REPACKING THE MACHINE	56
DRAWING A PATTERN ON THE DESIGN CARD	57
TO KNIT GARMENTS	58
(See page 58 for the contents of this section.)	
TO USE THE CHUNKY RIBBER, SR155	85
(See page 85 for the contents of this section.)	

MACHINE AND ACCESSORIES

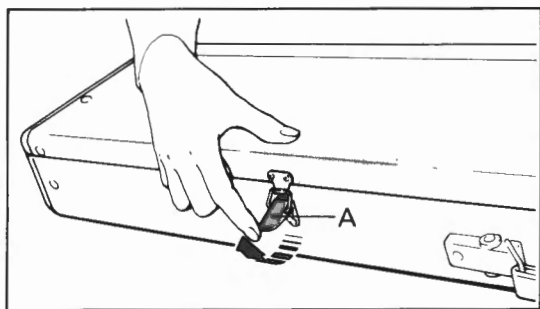

Machine

Place the machine on the table with Carrying Handle away from you.

Unfasten the Latches "A".

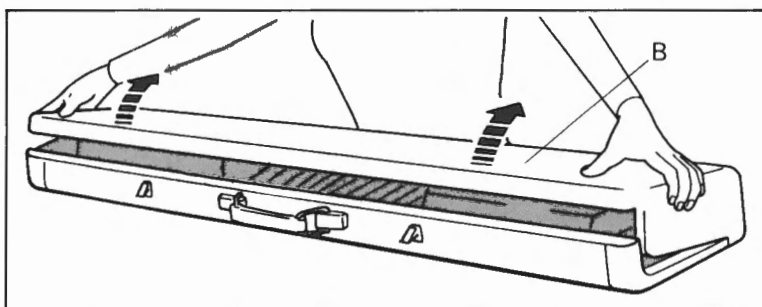

Lift the Top Cover "B" slightly. Pull the cover towards you to remove it from the machine.

Place the Top Cover as shown below.

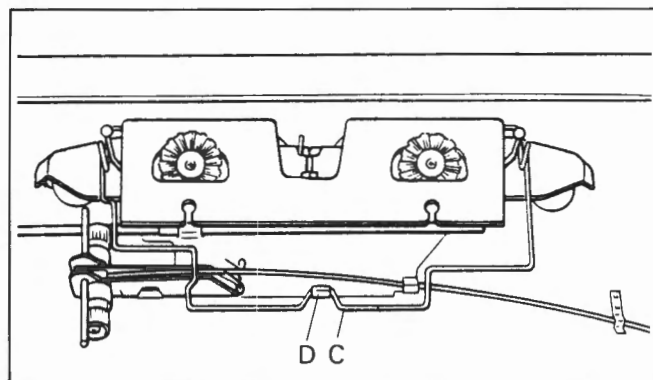
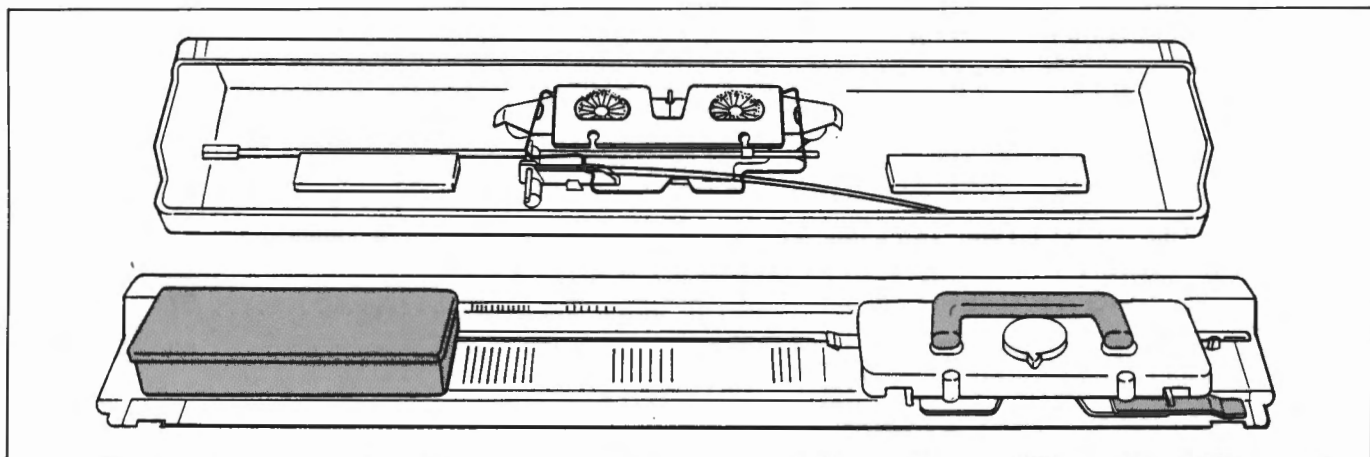

Release the wire spring "C" from the holding bracket "D" inside the Top Cover.

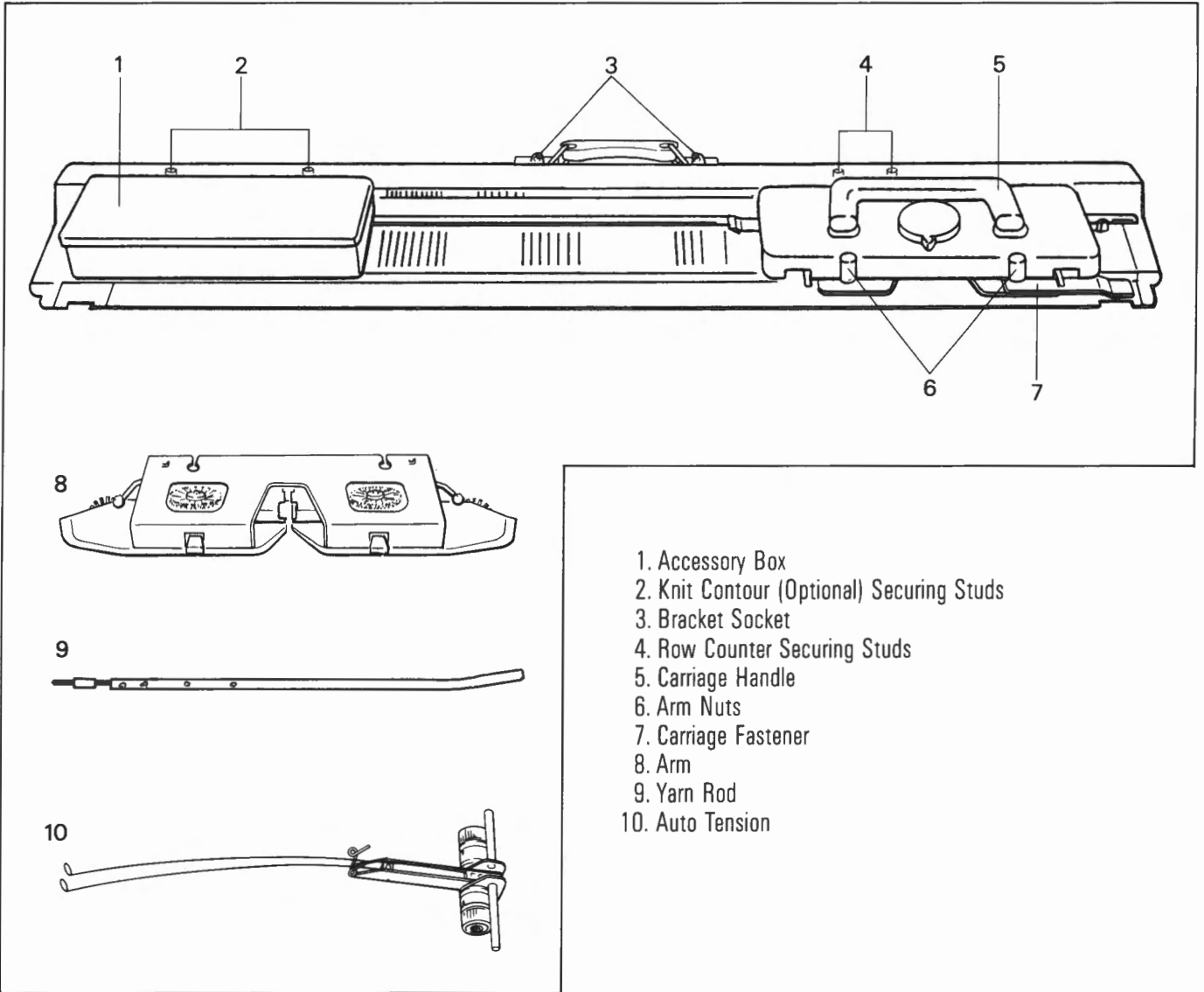

- 1. Accessory Box
- 2. Knit Contour (Optional) Securing Studs
- 3. Bracket Socket
- 4. Row Counter Securing Studs
- 5. Carriage Handle
- 6. Arm Nuts
- 7. Carriage Fastener
- 8. Arm
- 9. Yarn Rod
- 10. Auto Tension

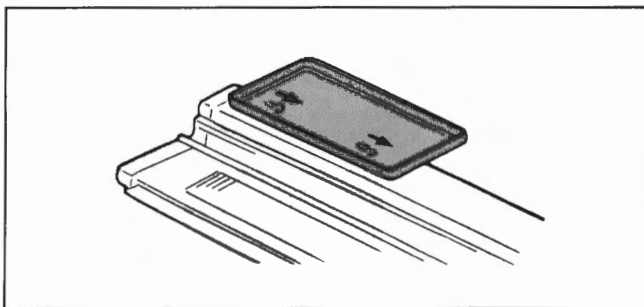

Accessory Box

Remove the Accessory Box from the Needle Bed and open the lid. Use the lid as a tray for the accessories or "Knit Contour, KR 10" by fitting it to the studs on the left side of the machine. When you use it as the Knit Contour's tray, refer to page 84.

Accessories

The following are packed in the Accessory Box.

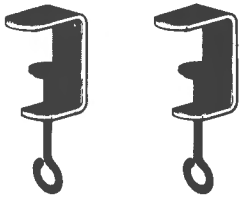

Clamp (2)

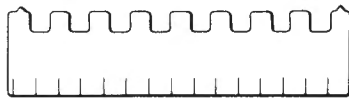

Needle Pusher



Tappet Tool

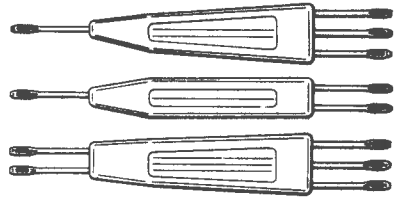

Transfer Tool
(one of each)
1 — 3
1 — 2
2 — 3

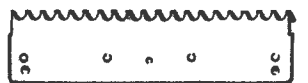
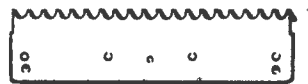

Wide Claw Weight (3)

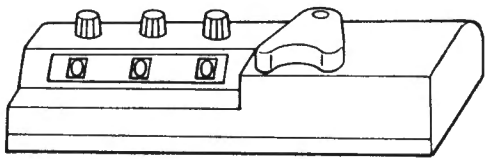

Row Counter

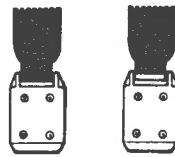

Claw Weight (2)



Tuck Brush (left & right)

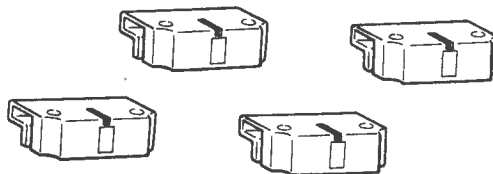

*Point Cam (4)



Needle-1 Cam (2)

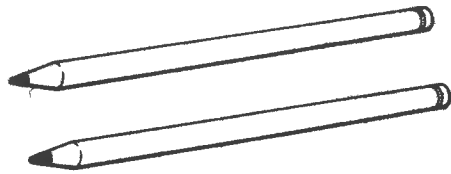

Design Pencil (2)



Tapestry Needle

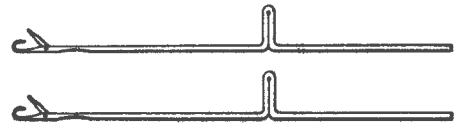

Spare Needle (2)



Ravel Cord (3)



Crochet Hook

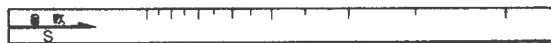

Gauge Scale

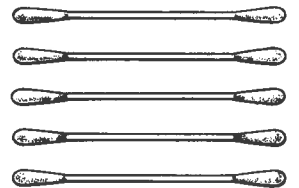

Sensor Cleaner



Oil

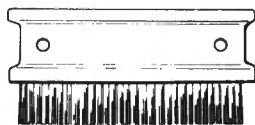

Cleaning Brush

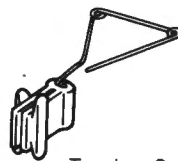

Tension Guide



* Carriage Fastener

* Two of the Point Cams have been set on the Needle Bed.

* The Carriage Fastener is used for securing the Carriage to the Needle Bed.

SETTING UP THE MACHINE

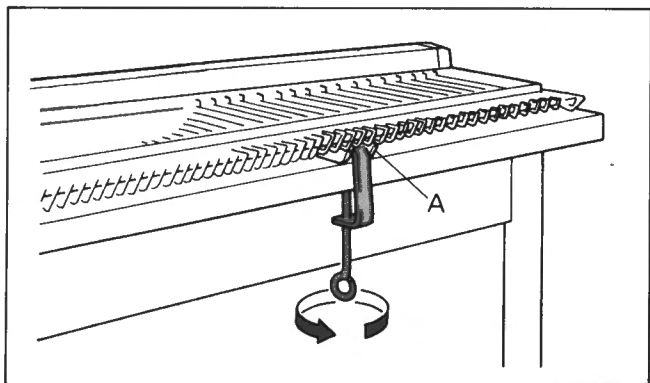

Insert the Clamps into the slots "A" at the bottom of Needle Bed.
Fasten the Clamps by turning screws in the arrowed direction.

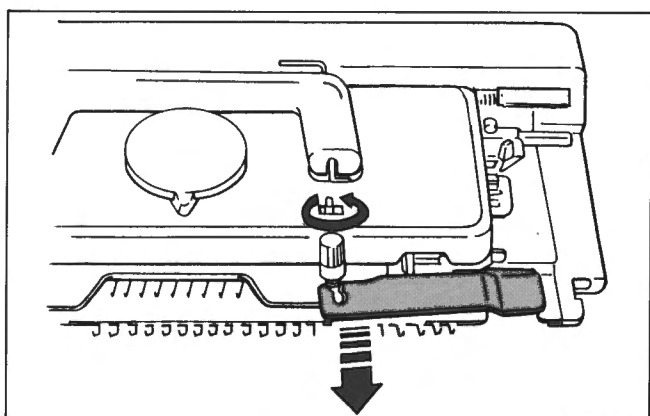

Loosen both Arm Nuts by turning them in the arrowed direction.
Remove the Carriage Fastener.

Keep the Carriage Fastener in the accessory box. Use it to keep the Carriage in place while moving the machine.

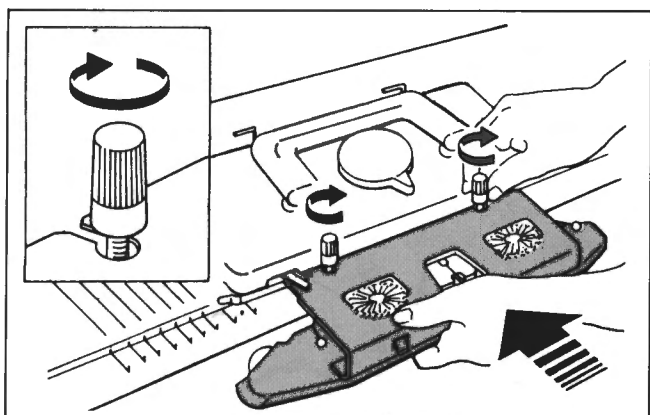

Remove the Arm from the Top Cover and position it under the two Arm Nuts screws.

Hold the Arm securely against the Carriage, and tighten the Arm Nuts by turning them in the arrowed direction.

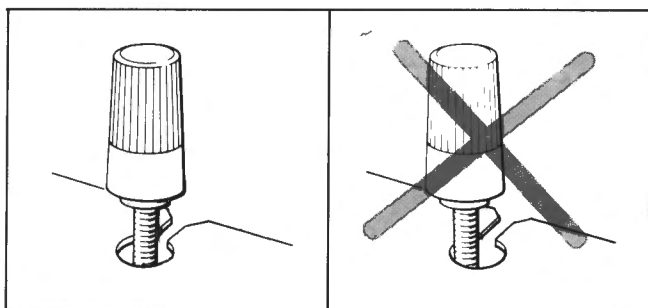

Ensure that the Arm Nuts fit properly into the cut-out of the Arm.

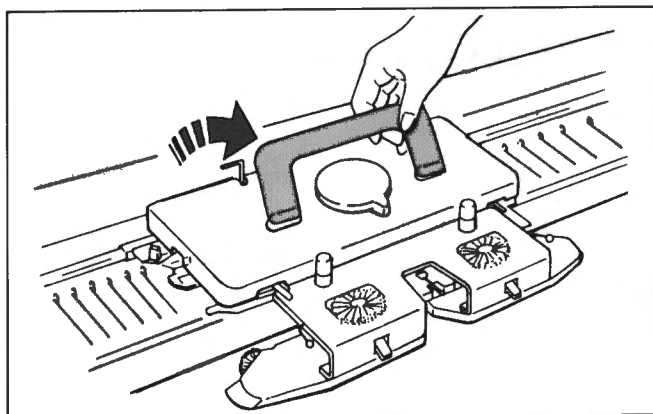

Raise the Carriage Handle, until it clicks into position.

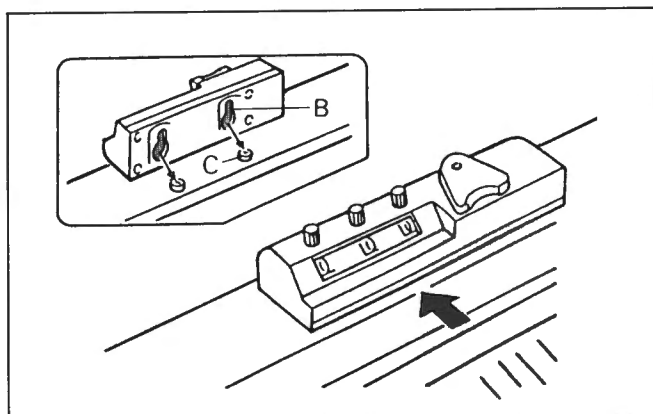

Attach the Row Counter by fitting the slots of the Counter "B" to the Studs "C" on top of the machine.

Remove the Auto-Tension and Yarn Rod from the inside of the Top Cover.

Insert the short bent end of the Yarn Rod "D" into the one of the Handle Bracket Sockets.

Turn the Tension Springs "E" until they click into position.

Fit the Auto-Tension to the top of the Yarn Rod.

Align the notch of the Yarn Rod with the groove of the Tension Guide "F" and insert the guide from above.

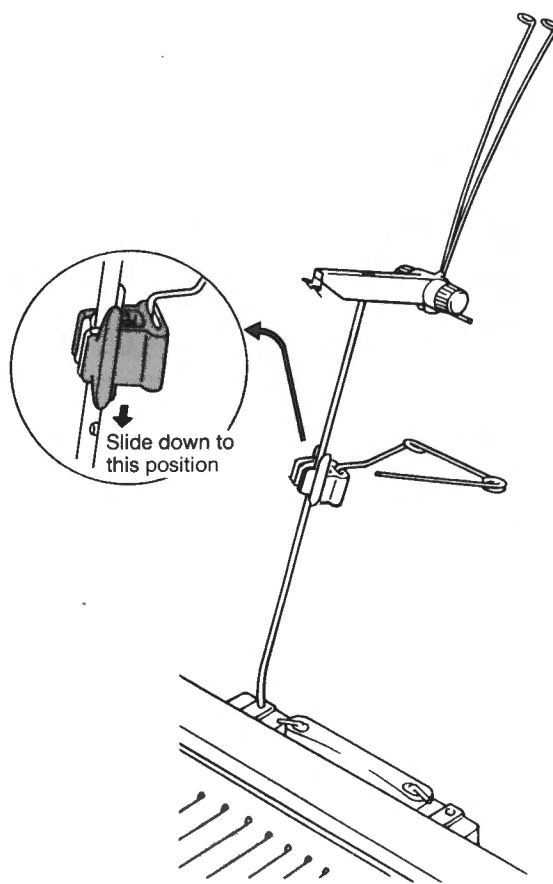
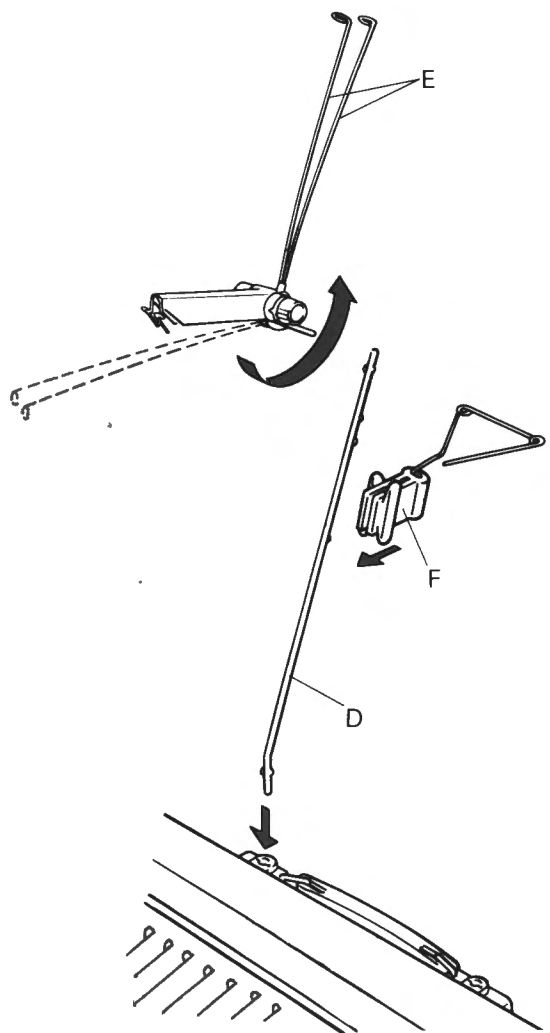

NAMES AND FUNCTIONS OF EACH PART

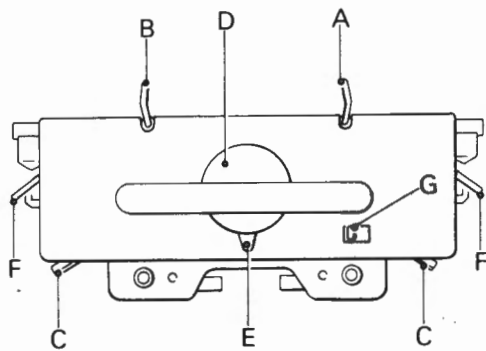
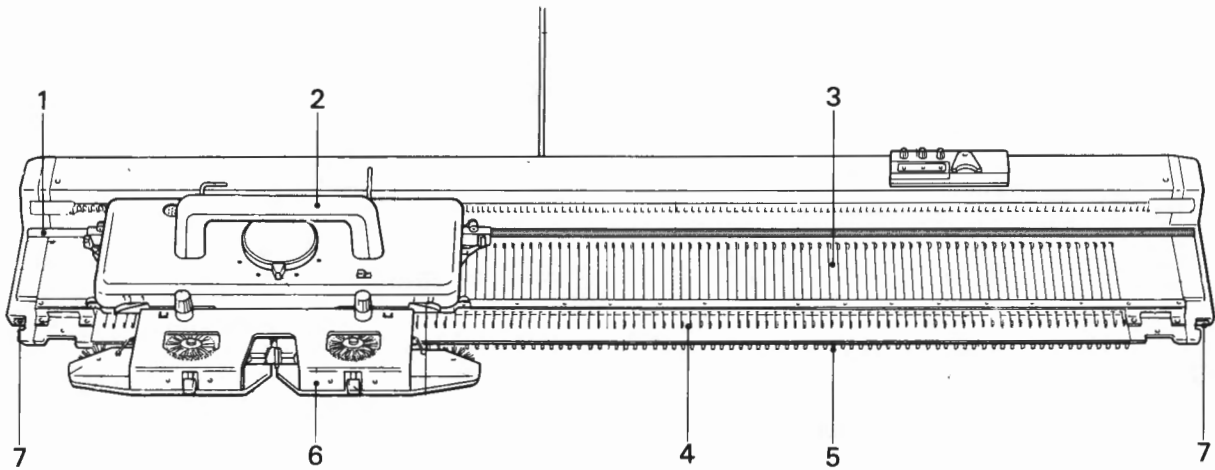

- 1. Rail
- ← 2. Carriage
 - A — RC Tripper
 - B — KC Tripper
 - C — Russel Levers
 - D — Stitch Dial
 - E — Cam Lever
 - F — Side Levers
 - G — Release Lever



- 3. Needle Bed
- ← 4. Latch Needle
 - A — hook
 - B — latch
 - C — stem
 - D — butt
 - E — shank
- 5. Sinker Post

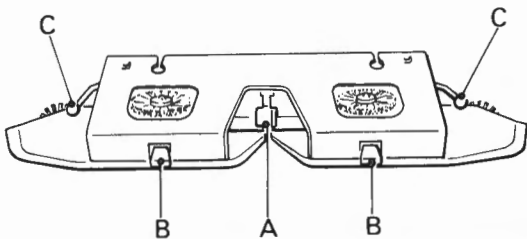

- ← 6. Arm
 - A — Yarn Feeder
 - B — Weaving Knobs
 - C — Weaving Yarn Holders
- 7. Yarn Holders

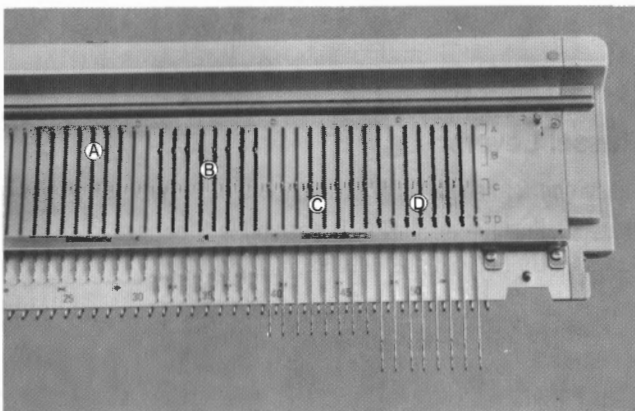

Needle Positions

On both ends of Needle Bed are bracketed letters A, B, C and D.

Align the needle butts inside the brackets.

- A — Needles do not knit.
- B — Needles knit Stockinet and stitch patterns.
- C — Needles knit Stockinet only.
- D — Needles do not knit with Russel Levers at I.
Needles are knitted back to B position with Russel Levers at II.

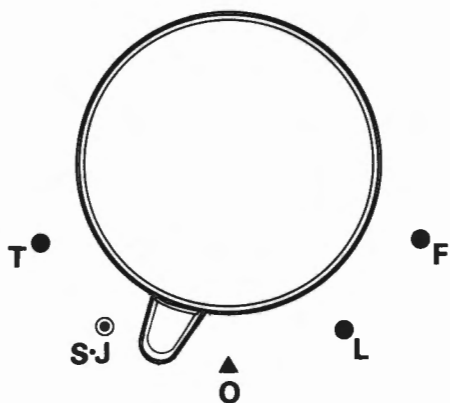

Cam Lever

Use this to select stitch type.
Five positions are marked as shown opposite, and each position is selected by setting the Cam Lever to the selected stitch type.

- O**.....STOCKINET, WEAVING, CAST-ON
- S·J**.....S for SLIP STITCH
 J for DOUBLE JACQUARD
- T**.....TUCK STITCH
- L**.....PUNCH LACE
- F**.....FAIR ISLE (KNIT-IN)

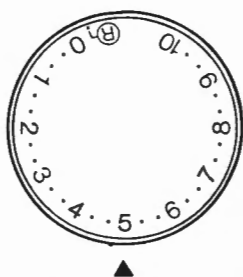

Stitch Dial

Use this to regulate the size of stitches. Set the number to the ▲ mark at the front. The higher the number on the Stitch Dial, the larger the stitch size. (The knitting is loose.) The lower the number, the smaller the stitch. (The knitting is tight.)

Ⓡ is selected when the Ribber (optional) is attached.

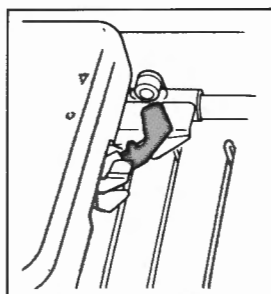
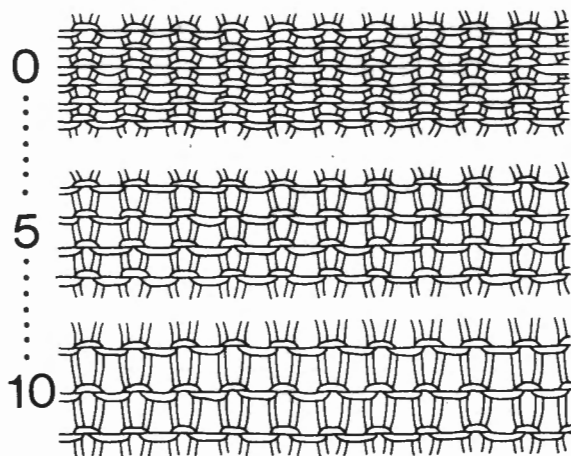

Side Levers

These control needles in B position.

- ▼.....Set to this position to knit patterns, using a Pattern Card.
-Needles knit Stockinet only.

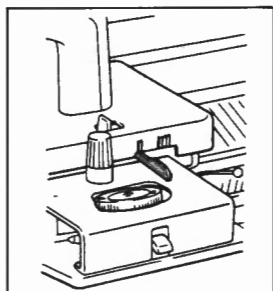
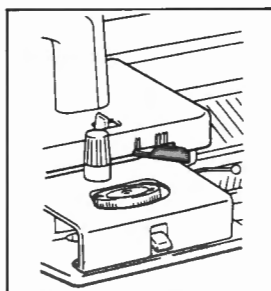

Russel Levers

These control needles in D position.

- ▯.....Knit the needles in D position in Stockinet.
- ┆.....Do not knit the needles in D position.

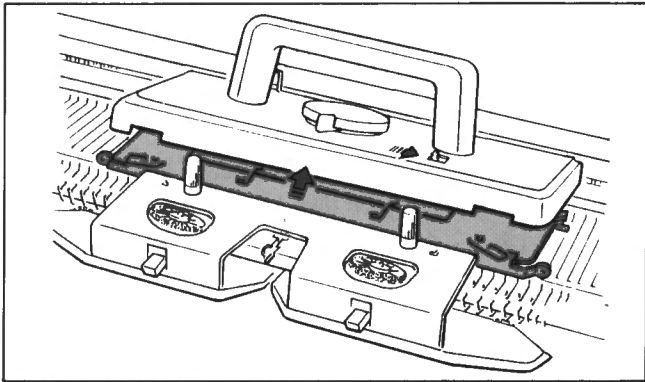

Release Lever

By using this lever, you can release the Carriage from a jam, as well as move it across the bed without knitting.

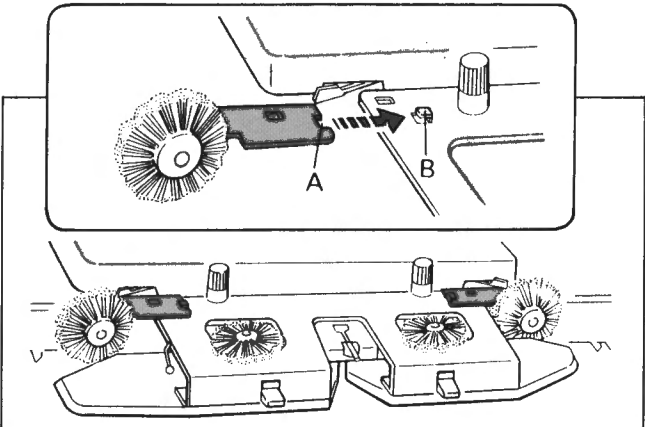

Tuck Brushes

Attach the right Tuck Brush on the right side of the Arm and the left Tuck Brush on the left side, placing the cut-out of Brush "A" under stud "B" on the Arm.

Depending on the type of yarn, the stitches may be loose on the needles. The Tuck Brushes can be used to rectify this, in addition to being used for Tuck Stitch.

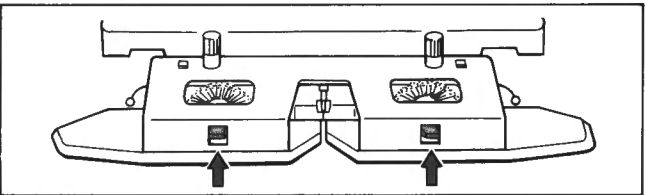

Weaving Knobs

Move these knobs to position the Weaving Brushes.

○..... Set to this position except for Weaving.

~..... Set to this position for cast-on and Weaving.

To set the Weaving Knob to ~, push it up, the Weaving Brush will drop into position.

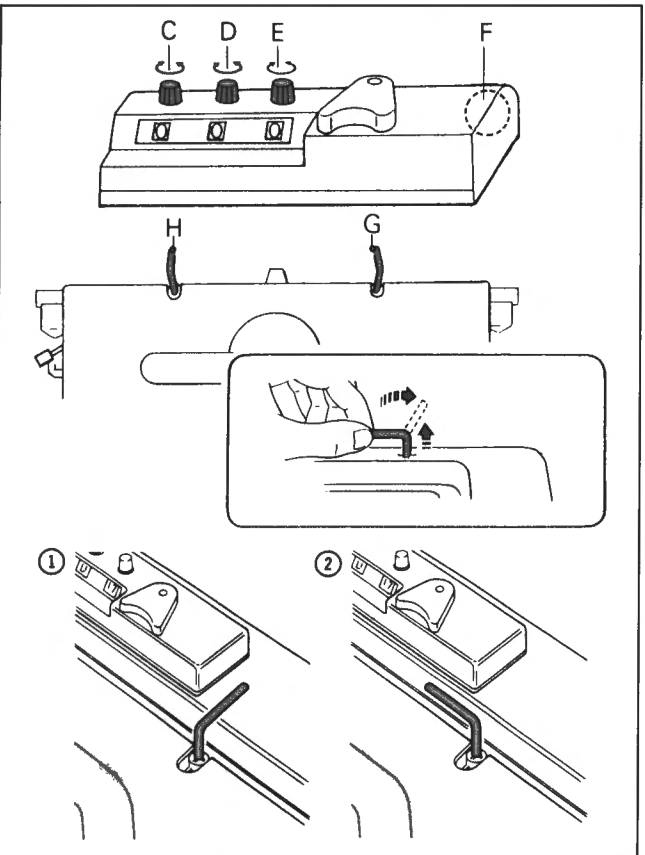

Row Counter and Feeding Trippers

The Row Counter counts the knitted rows automatically. To reset number, turn the knurled knobs "C" "D" and "E" in either direction.

The socket "F" at the top of the Row Counter is used for attaching the Electronic Knit Contour KR 10 (optional). Refer to page 84.

The Feeding Tripper "G" on the right side of the Carriage operates both the Row Counter and the Knit Contour Attachment (optional) if it is in use.

The Feeding Tripper "H" on the left side of the Carriage operates the Knit Contour Attachment only. (KR 7 only).

To engage either Feeding Tripper with the Row Counter or Knit Contour, lift it up, and turn it towards the back of the Needle Bed. To disengage the Feeding Trippers, lift and turn to the side.

① Feeding Tripper is in working position.

② Feeding Tripper is in non-working position.

YARN PREPARATION

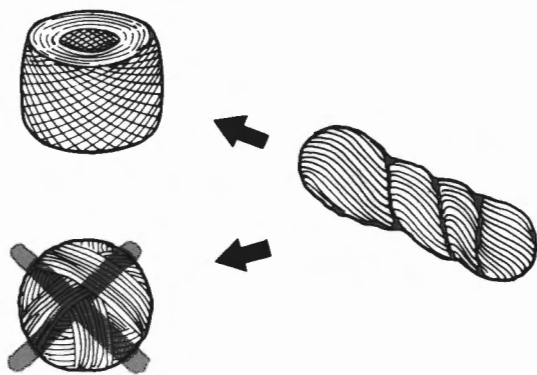

Your machine is designed to knit wide variety of bulky yarns, but it is recommended to use extra thick yarn for practice. (See page 12).

Correct preparation of yarns before you start knitting is very important. This will make knitting more enjoyable and easier. The quality of your garment will be much improved.

It is impossible to knit from a hank of yarn or hand wound ball.

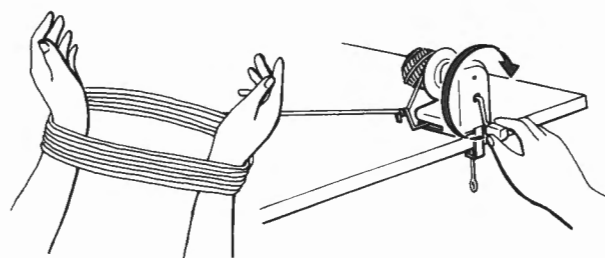

Open the hank of yarn and replace it on your arms (or on an optional Skein Holder) to wind it into a ball, suitable for machine knitting.

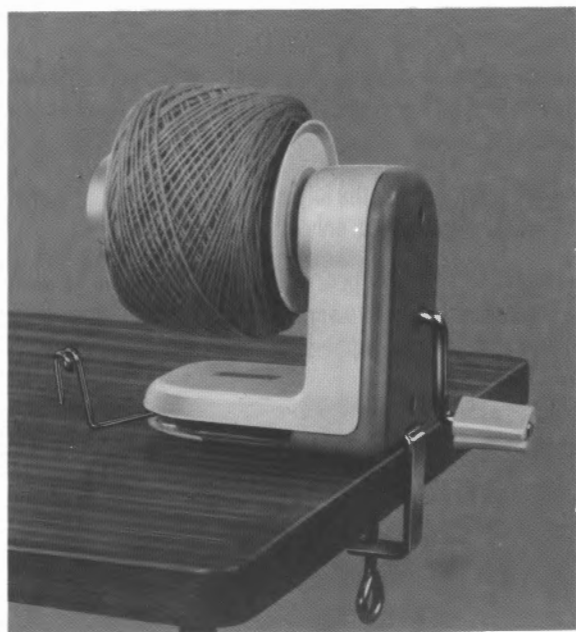
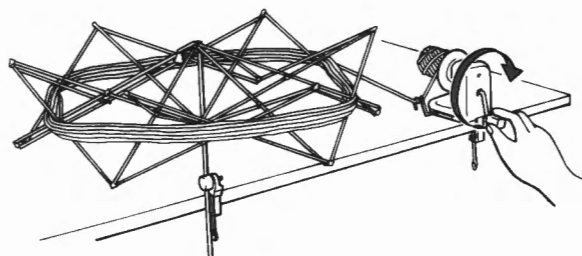

An optional Yarn Ball Winder is recommended for winding yarn.

When yarn is rewound, ensure that the yarn end comes out freely without lifting the ball.

If the ball has been wound too tight for the yarn to come out freely, rewind more loosely.

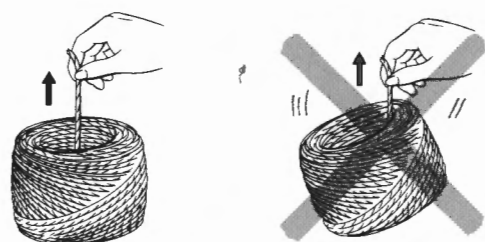

THREADING THE YARN

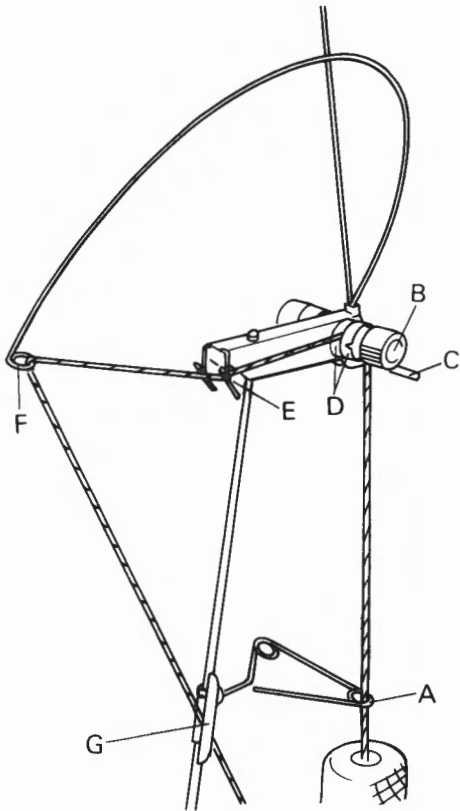

For practice, prepare extra thick yarn.

Thread the right side of Auto Tension as follows:—

- ① through right Tension guide eyelet "A",
 - ② between Tension Dial "B" and Guide Bar "C",
 - ③ between two Tension Discs "D",
 - ④ through right Yarn Guide eyelet "E",
 - ⑤ through right Tension Spring eyelet "F".
- Put the yarn end under Yarn Clip "G".

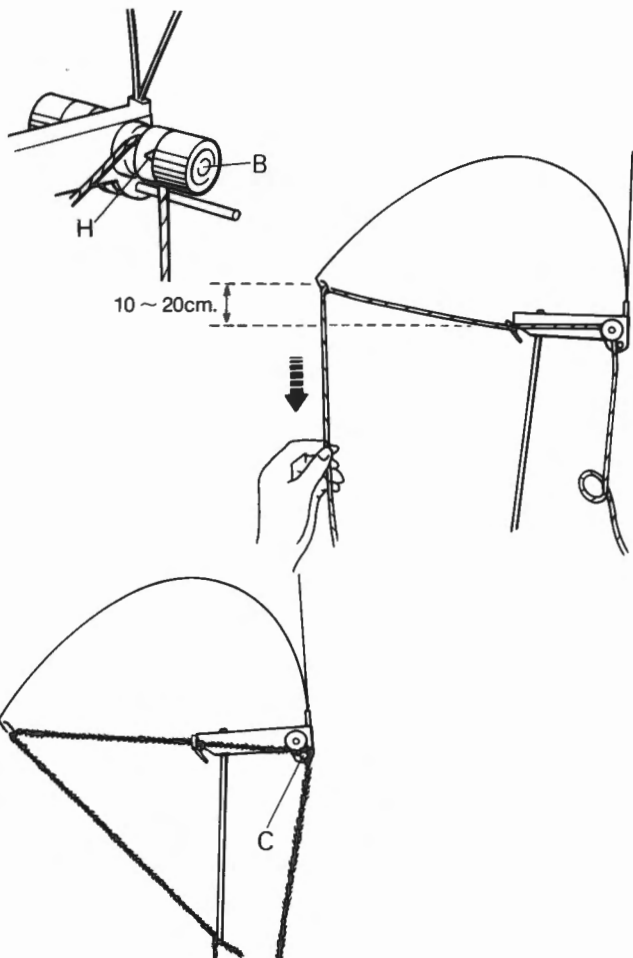

Adjusting Tension Dial

Adjust the Tension Dial according to type of yarn by turning the Tension Dial "B" until required number corresponds to the Δ shape "H" using the following as a guide:—

1. Yarn comes out freely from the yarn ball.
2. Distance between the Tension Spring and the horizontal line — 10~20cm. must be maintained.

The higher the number, the tighter the tension. The lower the number, the looser the tension.

If you use heavy weight slub yarn, place it over the Guide Bar "C" only, not between tension discs "D".

It is advisable to pull out a certain length of the yarn from the yarn ball before casting on.

YARN AND STITCH DIAL

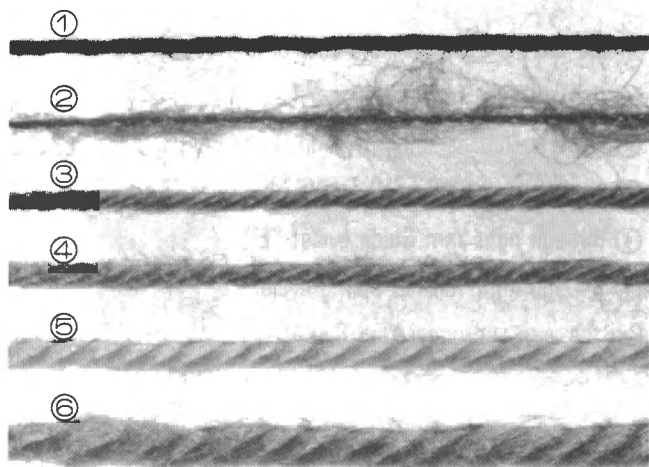

To obtain suitable stitch size, or suitable tension for a garment, set the Stitch Dial Number according to the thickness of the yarn, referring to the yarns and table opposite.

TYPE OF YARN	STITCH DIAL
① Medium thick	1 ~ 2
② Mohair	3 ~ 4
③ Very thick	5 ~ 6
④ Extra thick	6 ~ 8
⑤ Super extra thick	8 ~ 10
⑥ Super extra thick (every second needle)	6 ~ 7

The thicker the yarn, the higher the Stitch Dial Number, and the thinner the yarn, the lower the Stitch Dial Number.



A — Stitch Dial at 1 with medium thick yarn.

B — Stitch Dial at 5 with very thick yarn.

C — Stitch Dial at 9 with super extra thick yarn.

CAST-ON AND KNITTING

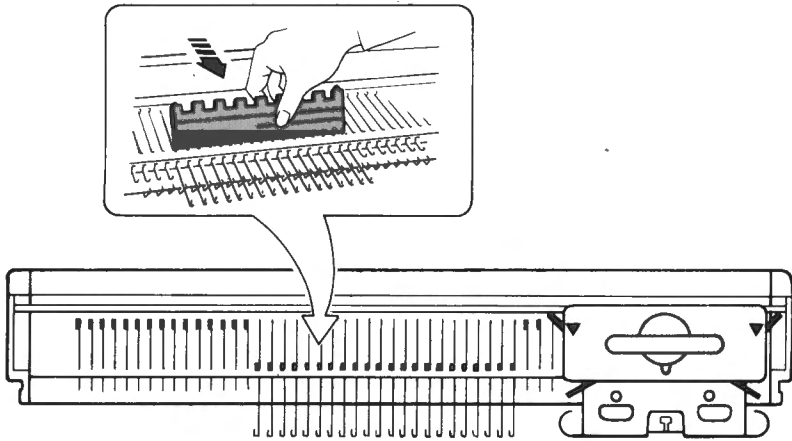

Cast-on (1) — weaving method —

Push the required number of needles from A position to D position.

Set the Carriage as follows.

- Cam Lever..... ○ (STOCKINET)
- Side Levers..... ▼
- Russel Levers..... ||
- Weaving Knobs..... ○

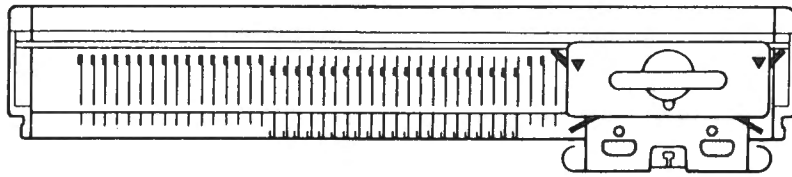

Slowly move the Carriage across the Needle Bed until it has passed all the needles.

The needles are aligned in B position.

Leave the Carriage on the right side.

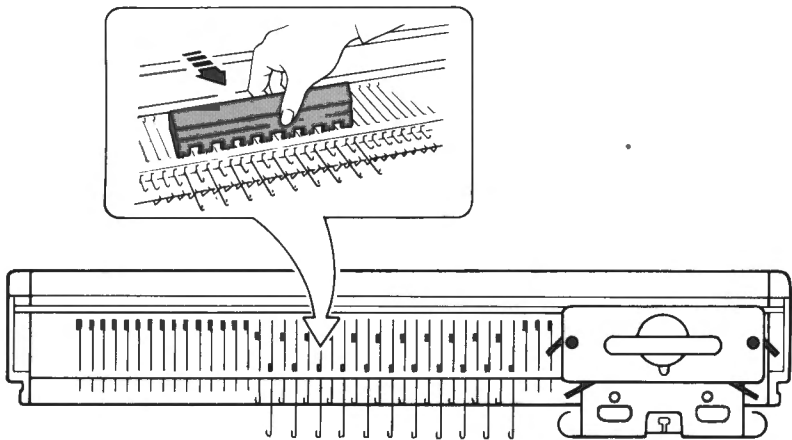

Using the Needle Pusher, push every 2nd needle from B to D position.

- Side Levers..... ●
- Weaving Knobs..... ~

Set the Stitch Dial referring to the table on page 12.

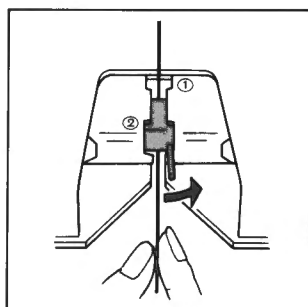
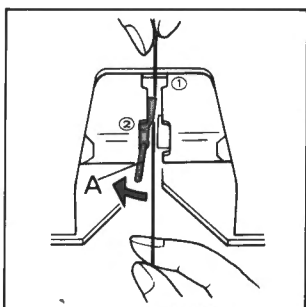

Open Yarn Feeder by moving the Yarn Feeder Gate "A" to the left. Remove the main yarn end from Yarn Clip and bring it to the Yarn Feeder.

Hold the yarn with both hands and slide it into the Yarn Feeder. Close the Yarn Feeder by moving the Yarn Feeder Gate to the right.

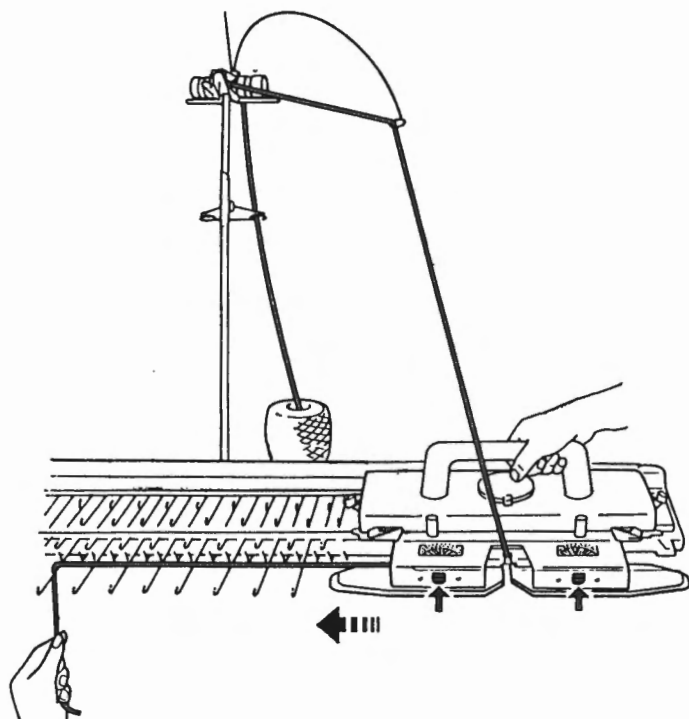

Pull the yarn end from underneath the Arm and lay it over all needles in D position.

Hold the yarn loosely at the left, about 30cm. from the yarn end.

Slowly move the Carriage from right to left until it has passed all the needles, knitting 1 row.

Ensure that the Arm has passed the last knitting needle by approximately 2 ~ 3cm. before beginning the next row.

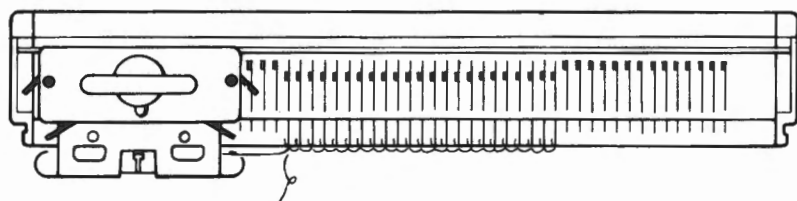

Continue to knit 2 ~ 3 rows.
Cast-on has been finished.

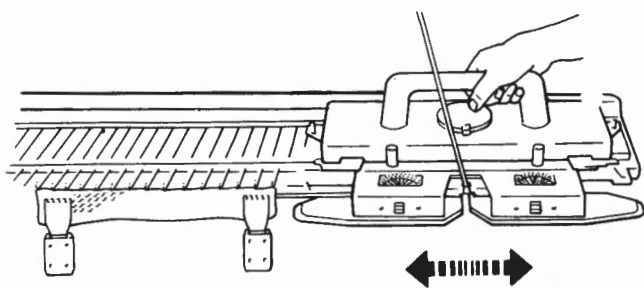

Set Weaving Knobs at **O**.

Knit 4 ~ 5 rows and hang Claw Weights at both ends of the knitting.

Move the Carriage from side to side to knit Stockinet.

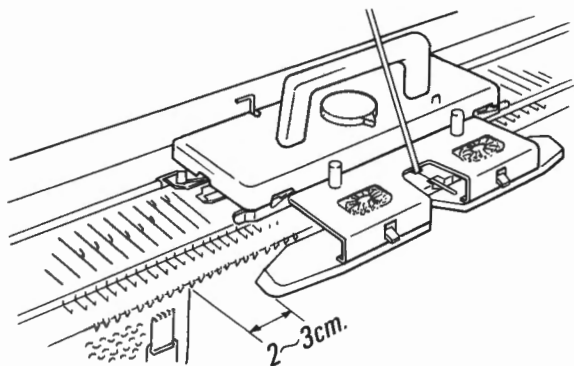

Ensure that the Arm has passed the last knitting needle by approximately 2 ~ 3cm. before starting the next row.

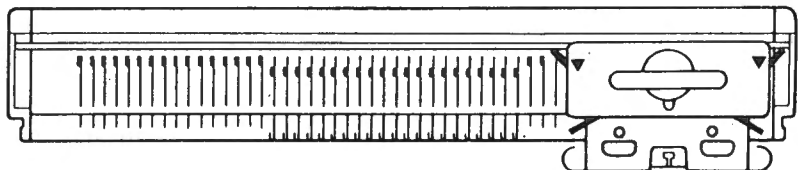
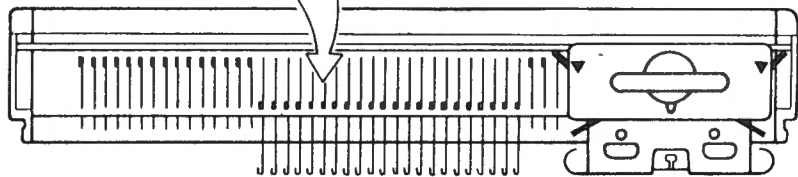
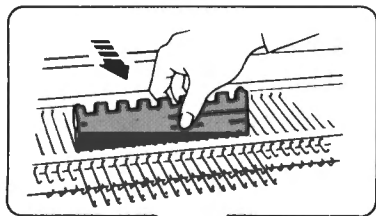

Cast-on (2)

Push the required number of needles from A position to D position.

Set the Carriage as follows:—

Cam Lever..... ○ (STOCKINET)
 Side Levers..... ▼
 Russel Levers..... ||
 Weaving Knobs..... ○

Slowly move the Carriage across the Needle Bed until it has passed all the needles in D position. The needles align in B position. Leave the Carriage on the right side of the Needle Bed.

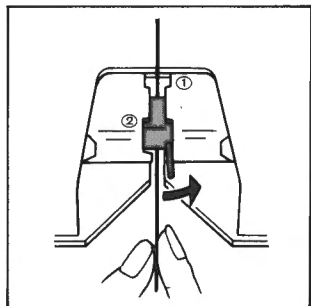
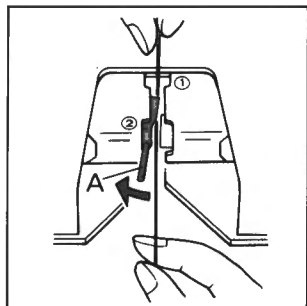

Open Yarn Feeder by moving the Yarn Feeder Gate "A" to the left. Remove the main yarn end from Yarn Clip and bring it to the Yarn Feeder.

Hold the yarn with both hands and slide it into the Yarn Feeder. Close the Yarn Feeder by moving the Yarn Feeder Gate to the right.

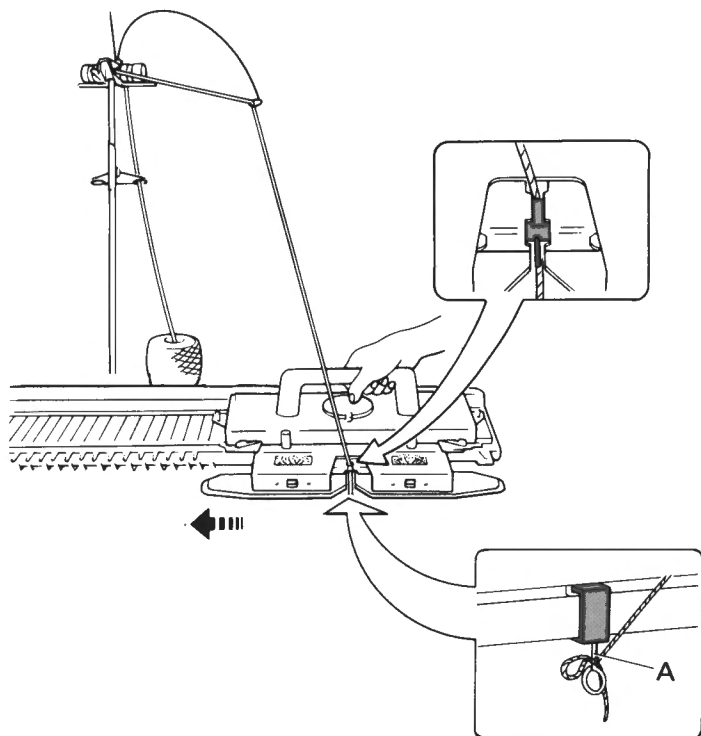

Tie the yarn end to the Clamp Screw Grip "A".

Set the Stitch Dial referring to the table on page 12.

Slowly move the Carriage from right to left until it has passed all the needles in B position.

Be sure to pass the Carriage over the last knitting needle by about 2 ~ 3cm.

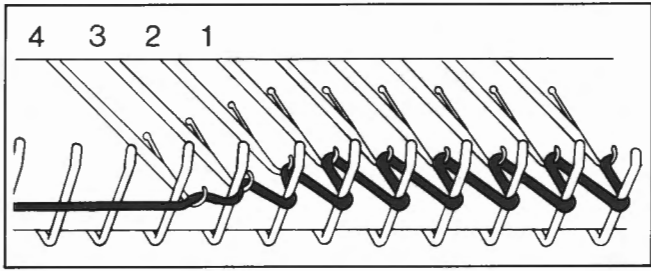

When knitting the first row, the loops may get smaller towards the edge.

To achieve a successful cast-on, these smaller loops must be increased in size.

To correct, hold yarn above the Yarn Feeder and pull it down to allow some slack.

Starting from the loop on the needle "1", push the needles with small loops one by one back to B position.

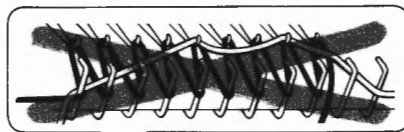
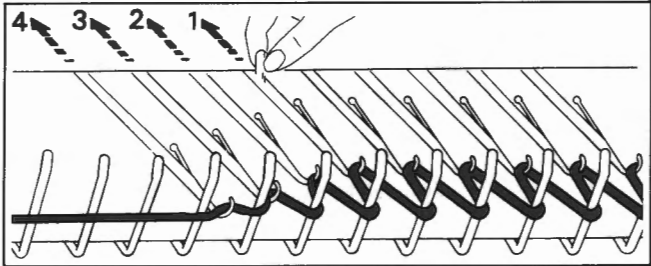

Take the Ravel Cord from the accessory box, and undo it.

Make sure that there is no knot in the cord. Place the end of the Ravel Cord "B" in the clip "C" at the right end of the Needle Bed as shown.

Lay the Ravel Cord across the yarn loops between needle hooks "D" and sinker posts "E". Pull the Ravel Cord with the left hand.

Ensure that the Ravel Cord lies correctly across the loops and is not caught in the needle hooks.

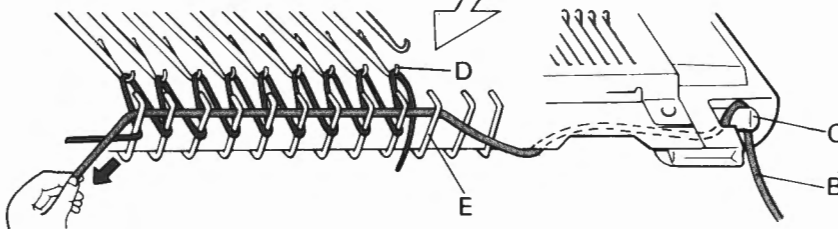

While pulling down the left end of the Ravel Cord, move the Carriage to the right side.

Continue to knit 5 ~ 6 rows.

Release the end of the Ravel Cord from the clip and pull it out from the left end.

Cast-on has been finished.

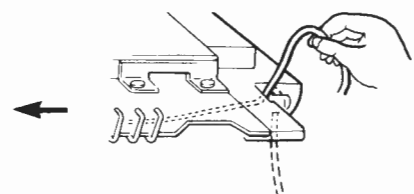
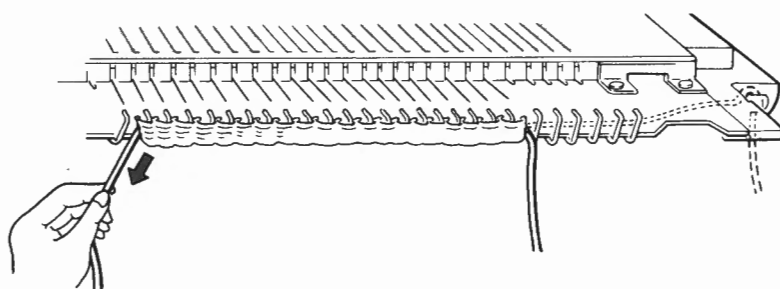
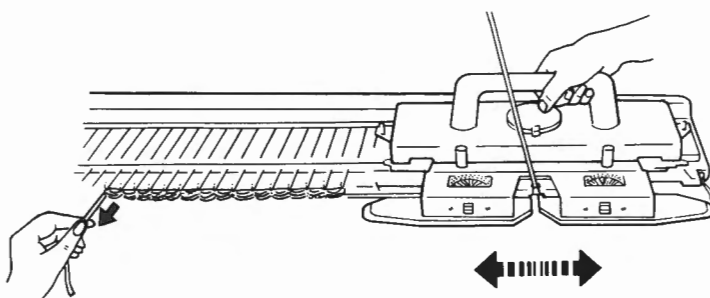

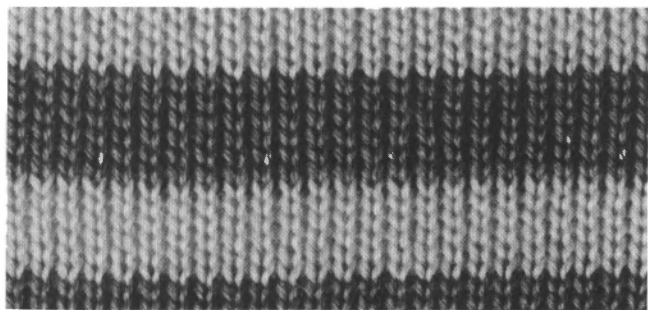

Knitting Stripe Pattern

Knit stripes by changing the yarn in feeder ① every few rows.

Cast-on with main yarn. (either method is acceptable.)

Knit 4 ~ 5 rows in Stockinet and hang Claw Weights at both edges of the knitting.

Unfasten the yarn end from the Clamp Screw Grip if you have used Cast-on method 2.

Open the Yarn Feeder by moving Yarn Feeder Gate "A" to the left. Remove main yarn from the Yarn Feeder.

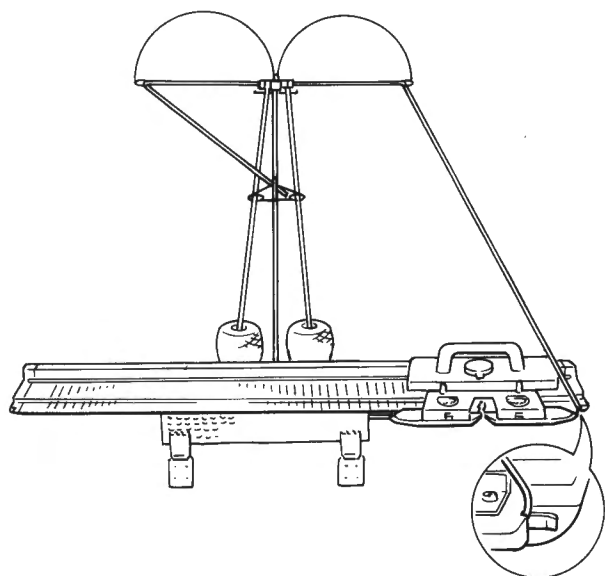
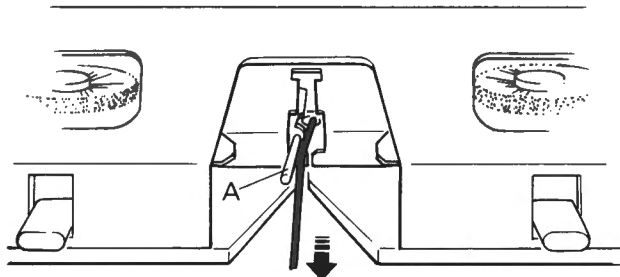

Place the main yarn in the yarn rest on the side of Needle Bed.

IMPORTANT!

The yarn in the left Tension Spring must always be placed in the yarn rest at the left end of the Needle Bed and the yarn in the right Tension Spring in the right yarn rest.

You must always rest the yarn at these ends of Needle Bed, no matter which side you change yarns.

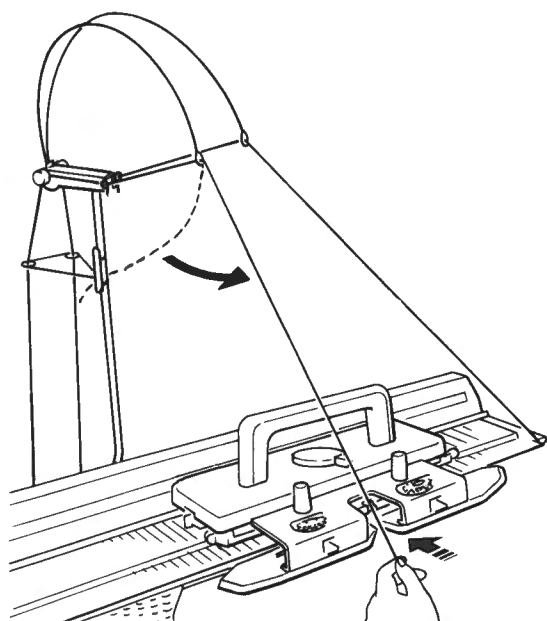

Remove the second colour yarn from the Yarn Clip and pull it down towards the Yarn Feeder.

Open Yarn Feeder by moving the Yarn Feeder Gate to the left and place the yarn in the Yarn Feeder.

Close the Yarn Feeder by moving the Yarn Feeder Gate to the right.

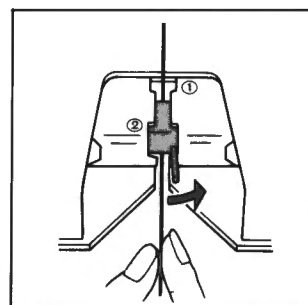
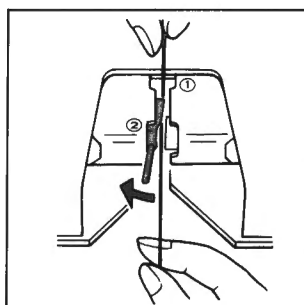

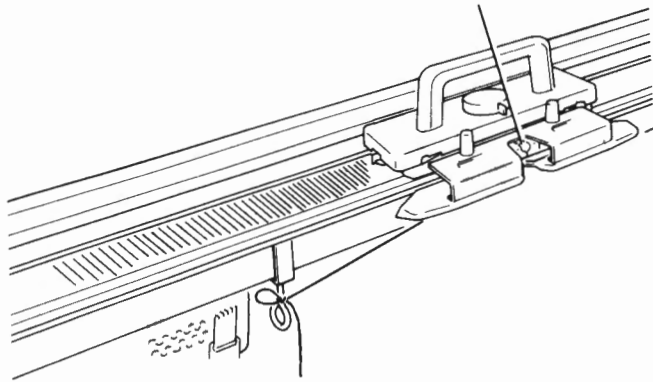

Fasten the yarn end to either Clamp.

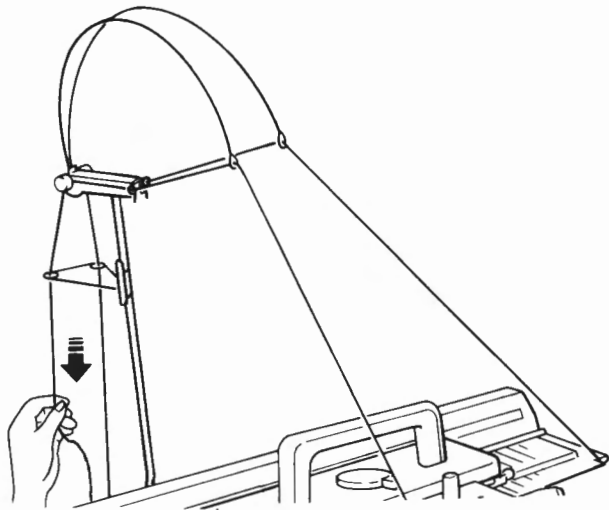

Eliminate slack yarn by pulling the yarn down at the back of Yarn Rod.

Knit even rows.

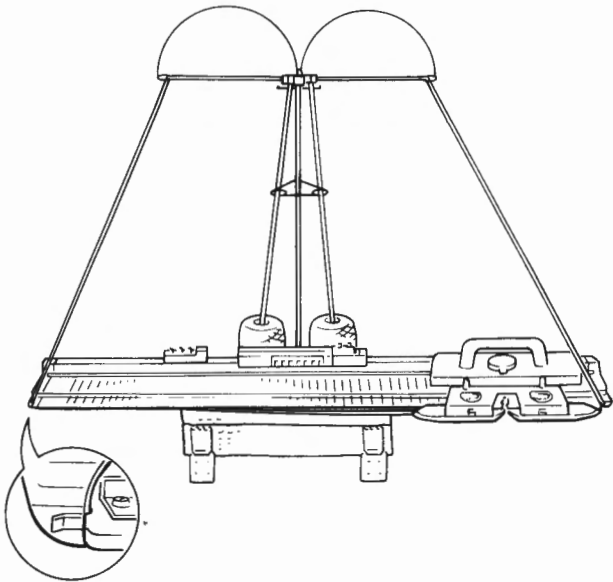

Remove the second colour yarn from Yarn Feeder ① and place it in the empty yarn rest.

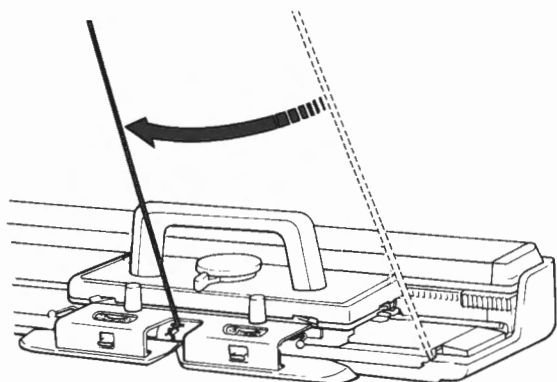

Remove the main yarn from the yarn rest and place it into the Yarn Feeder ①.

Eliminate slack yarn.

Knit even rows, using two yarns alternately.

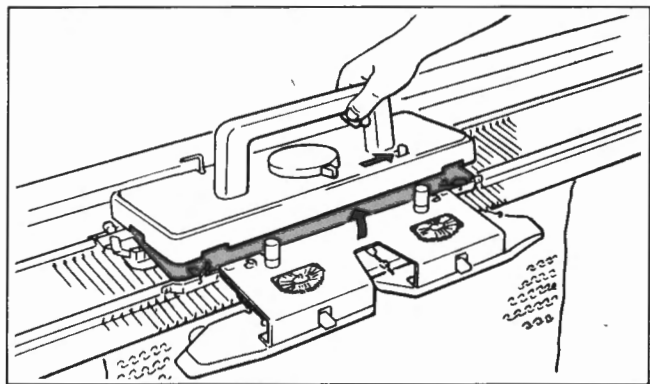

Moving the Carriage without Knitting

Stop the Row Counter, Pattern Panel, Knit Contour (optional).

Using Release Lever

Push this Lever to the arrowed direction to raise the main part of the Carriage and move the Carriage across the knitting.

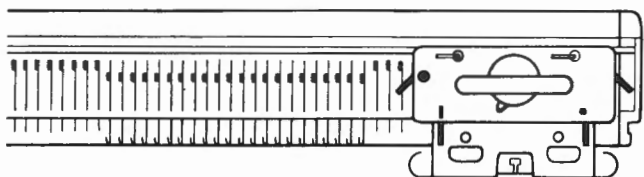

Using Cam Lever

Set the Carriage as follows and move it across the knitting.

Cam Lever.....S
 Side Lever (on side next to knitting).....●
 Russel Lever (on side next to knitting).....I

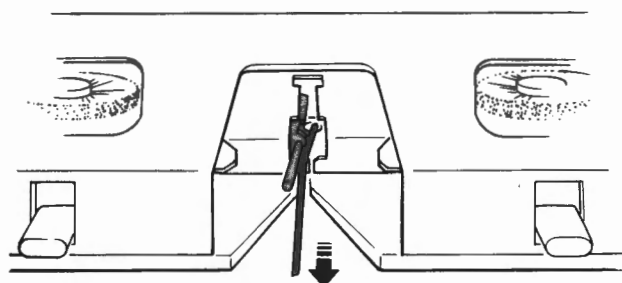

Removing the Knitting

— without casting off —

This is useful for removing tension gauge and samples quickly.
 Remove the yarn from Yarn Feeder.

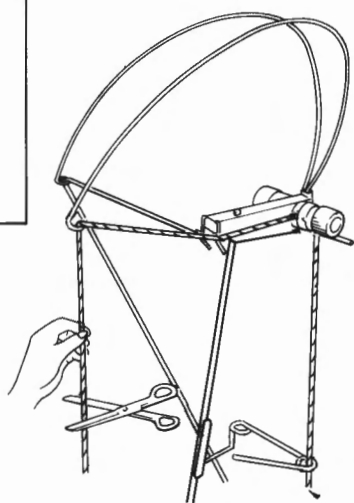
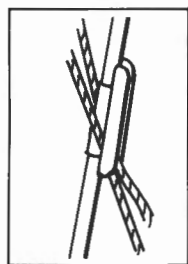

Hold the yarn between the Carriage and Tension Spring and cut it.

Place the yarn ends into the Yarn Clips.

Remove weights from the knitting.

Set Cam Lever to "O" and move Carriage across the knitting.

The knitting comes off the needles.

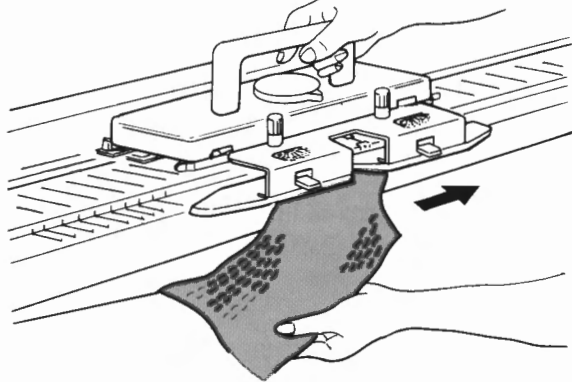

TO KNIT PATTERNS USING THE PATTERN CONTROLLER, EC1

CONTENTS

	page
PATTERN CONTROLLER, EC1	21
CONNECTING THE PATTERN CONTROLLER TO THE MACHINE	22
PATTERN CARD	23
POINT CAM AND NEEDLE-1 CAM	24
PATTERN PANEL	25
PATTERN WIDTH INDICATOR	28
SETTING THE PATTERN CARD	30
PRECAUTION IN PATTERN KNITTING	31
FAIR ISLE (KNIT-IN)	32
TUCK STITCH	35
TUCK LACE	36
SLIP STITCH	37
TUCK/SLIP STITCH PATTERN IN COLOURS	38
SINGLE MOTIF	39
WEAVING	41
PUNCH LACE	43

The Pattern Controller is available as an optional accessory.

PATTERN CONTROLLER, EC 1

The Pattern Controller is an unit necessary for pattern knitting with a Pattern Card.

Names of Each Part and Accessories

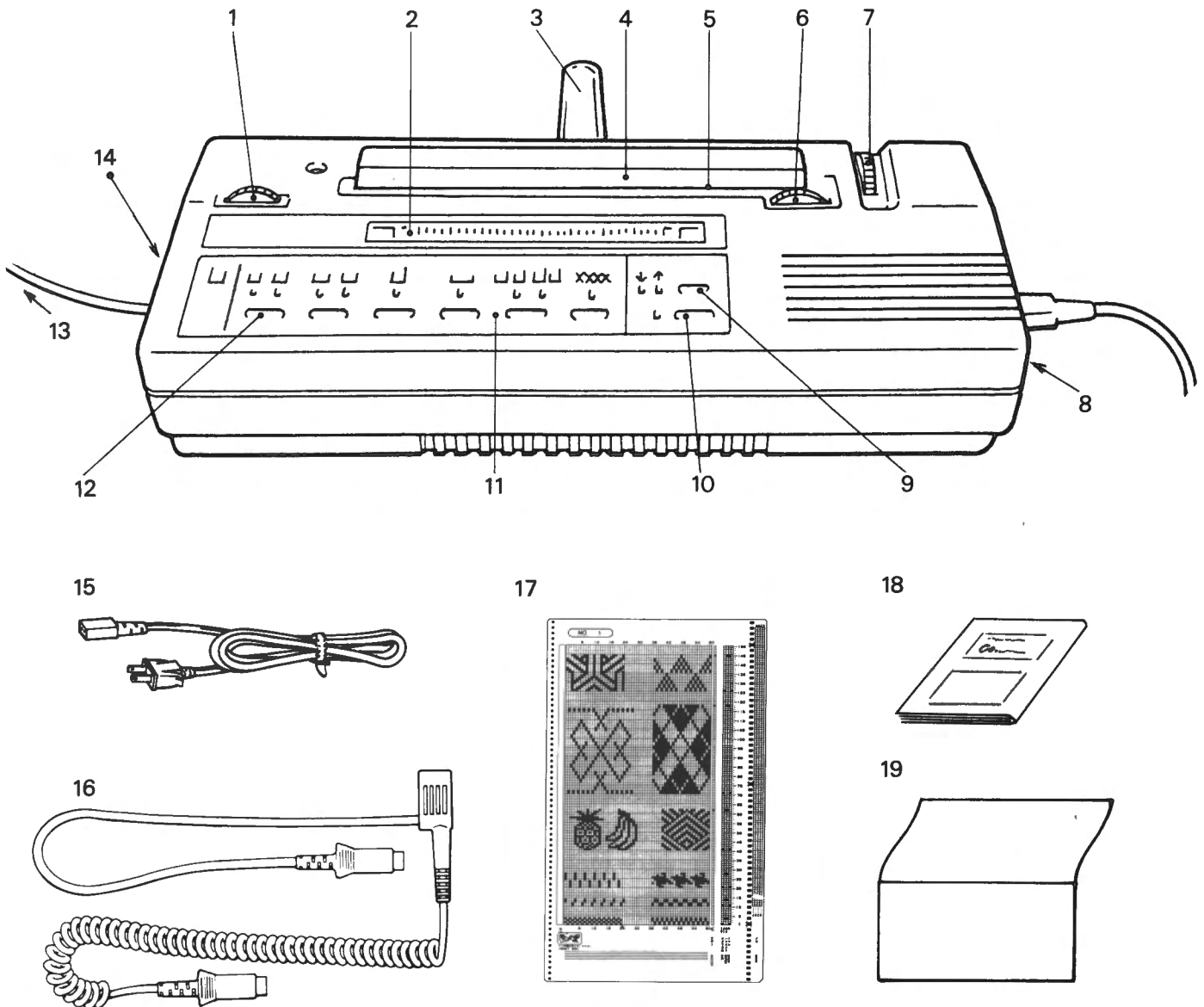

1. Left Pattern Dial
2. Pattern Width Indicator
3. Card Guide
4. Card Cover
5. Card Slot
6. Right Pattern Dial
7. Card Dial
8. On/Off Switch
9. Direction Switch

10. Inspection Switch
11. Pattern Panel
12. Pattern Switch
13. Connection Cord to the Curl Cord
14. Socket
(This is used for plugging the Connection Cord of the Design Controller into)
15. Power Cord
16. Curl Cord
17. Pattern Card (10), Design Card (5)
18. Pattern Collection
19. Card Cleaner

CONNECTING THE PATTERN CONTROLLER TO THE MACHINE

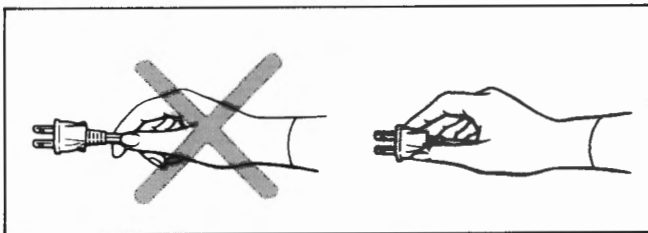
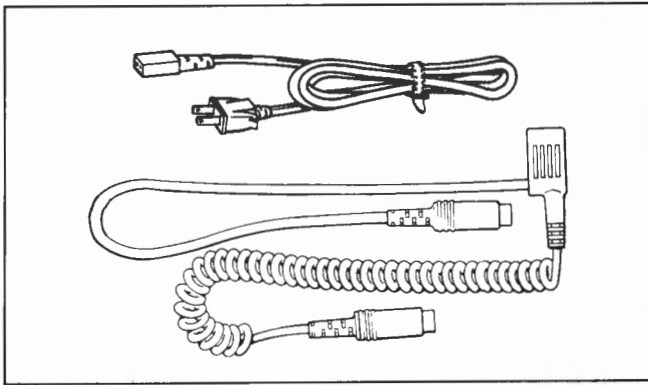

- ① Lift the Auto-Tension off the top of the Yarn Rod. Slide the block of the Curl Cord onto the Yarn Rod and replace the Auto-Tension. Slide the block down until it stops.
- ② Plug the Curl Cord into the socket of the Carriage with the mark ▼ to the front, corresponding to the ▼ on the Carriage.
- ③ Plug the straight cord into the Connection Cord of the Pattern Controller, matching the mark ▼ with the mark —.
- ④ Plug the Power Cord to the socket of the Pattern Controller.
- ⑤ Plug the Power Cord to the wall socket.

Don't switch on the controller, before plugging.

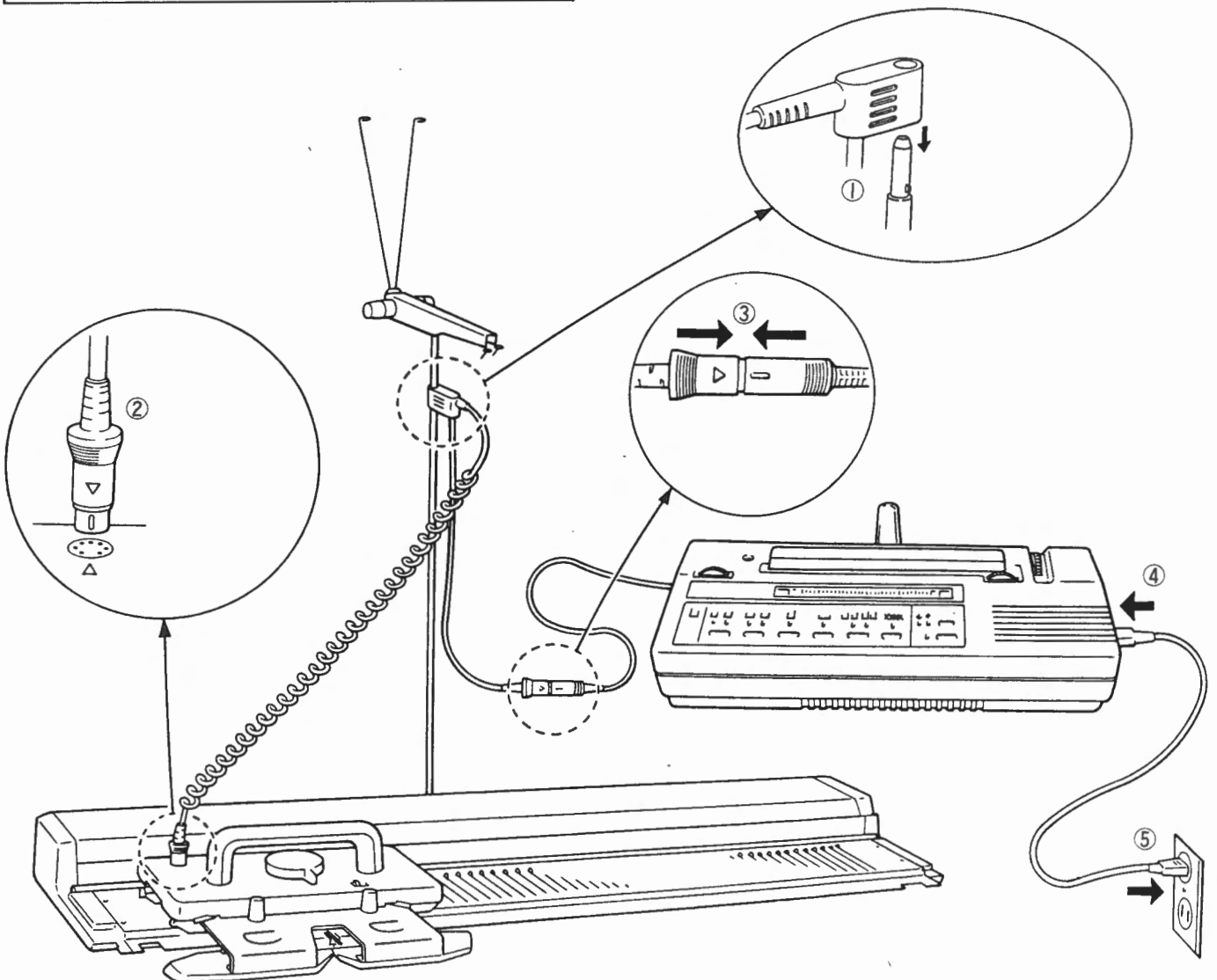

PATTERN CARD

PATTERN CARD is printed with rectangles. Each rectangle is proportional to the size of a stitch. The black area represents a pattern to be produced on a knitting.

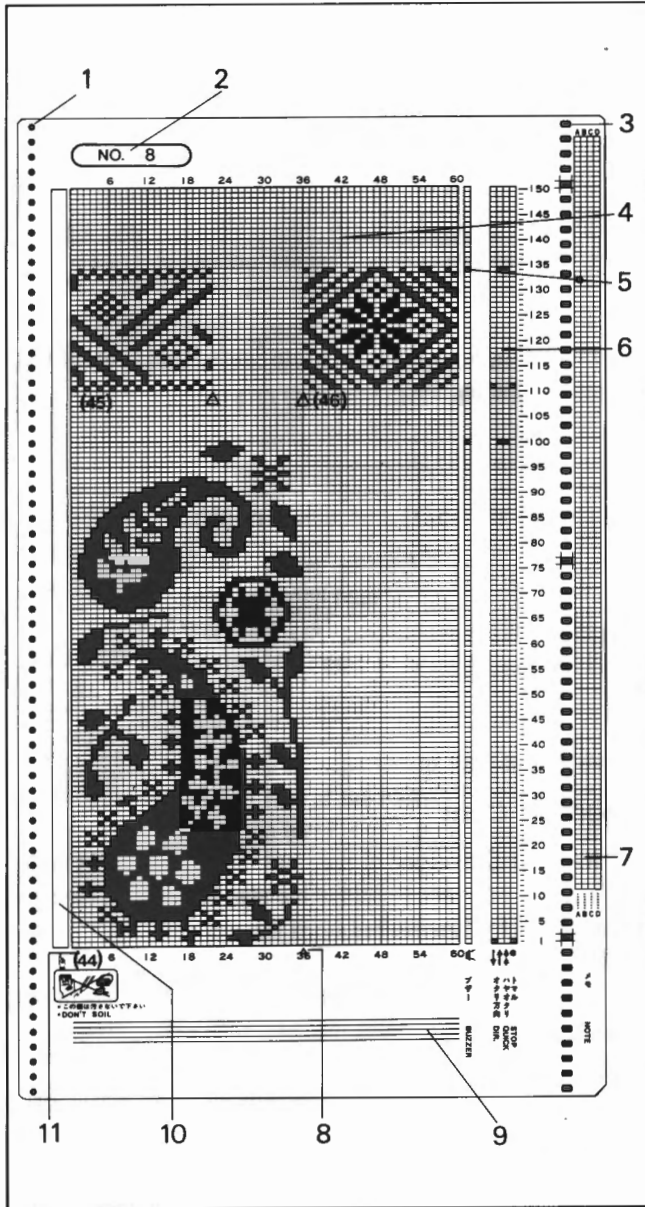

- 1 Feeding hole (left)
- 2 Card Number
- 3 Feeding hole (right)
- 4 Pattern area
A pattern of 150 rows and 60 stitches can be drawn in this area.
- 5 Buzzer column
The mark in this column operates the buzzer when the marked row is read.
- 6 Instruction columns (used to control the movement of Pattern Card).

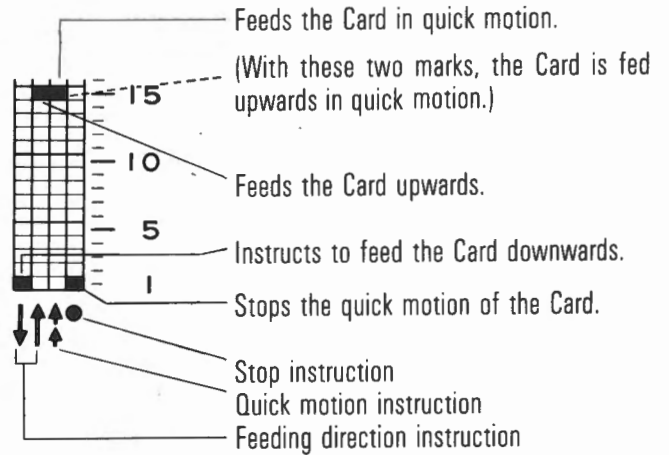

- 7 Notation column
Use this column to note the row to change yarn or other indication. (As there is a 10-row difference between the row to knit and the row visible above the Card Slot, be sure to mark the tenth row above the actual row to be knitted.)
- 8 Pattern width setting mark
The triangle shows where the Pattern Width Indicator can be set to vary the pattern. Set the Pattern Width Indicator corresponding with the triangle mark.
- 9 The horizontal lines are provided as a guide to ensure that the card is correctly inserted.
- 10 Do not soil this column.
- 11 Pattern number

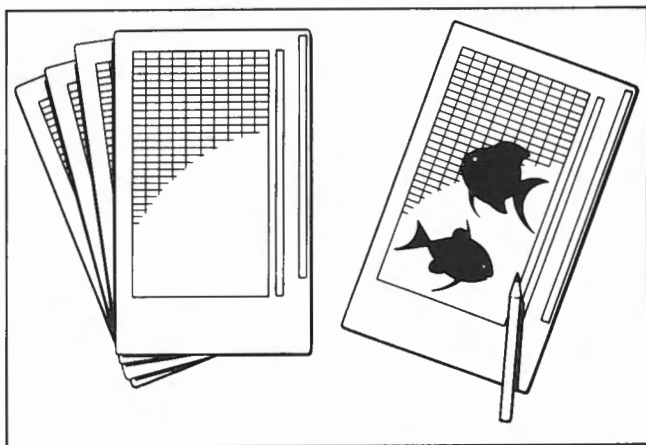

DESIGN CARD (5 sheets)

The Card is made of semi-transparent paper and has same rectangles as the Pattern Card. A pattern of your choice can be drawn on the Card using the Design Pencil. Refer to page 57.

POINT CAM AND NEEDLE-1 CAM

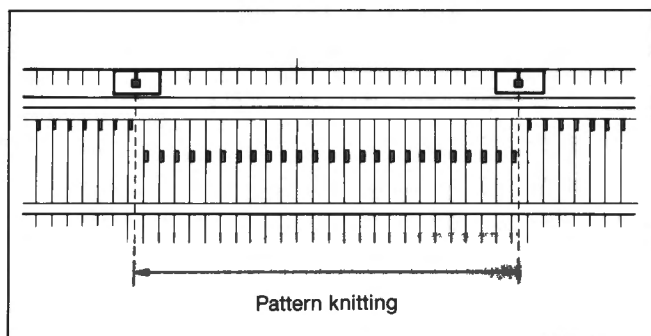

Point Cam

The Point Cams are the ones which slide along the rail at the back of the Needle Bed.

Pattern knitting only operates between the two Point Cams. (The Point Cams determine the range of pattern knitting.)

When setting the Point Cams at both edges of the knitting needles, the pattern will be knitted overall the knitting.

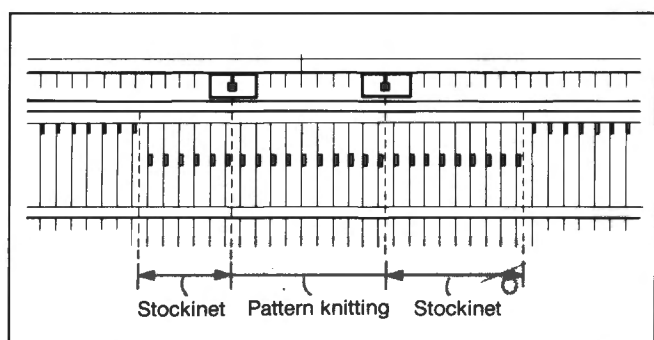

You can use the Point Cams to isolate Single Motif or to eliminate portions of the pattern.

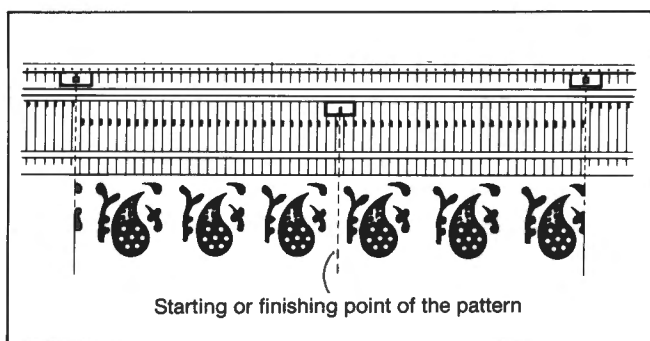

Needle-1 Cam

The Needle-1 Cam is one of the small rectangular blocks with a red line. This has pegs to hold it in place. The pegs fit the small holes behind the Needle Bed.

The red line of the Needle-1 Cam tells the machine where to start and finish the pattern repeat.

Usually, Needle-1 Cam is put at the center of the Needle Bed.

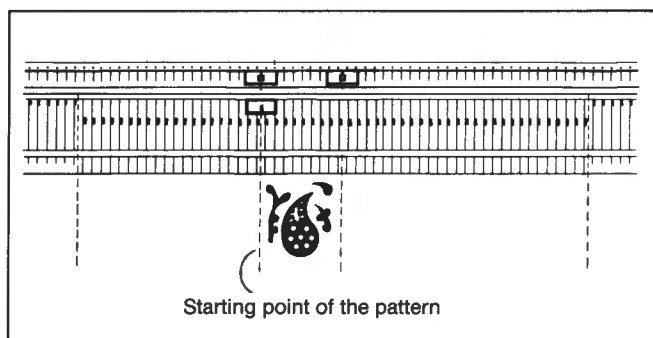

When knitting the pattern partially like Single Motif, put the Needle-1 Cam at either the left or right Point Cam as shown on the left.

You must put the Needle-1 Cam within the two Point Cams or at either Point Cam. Don't put it outside the Point Cams.

PATTERN PANEL

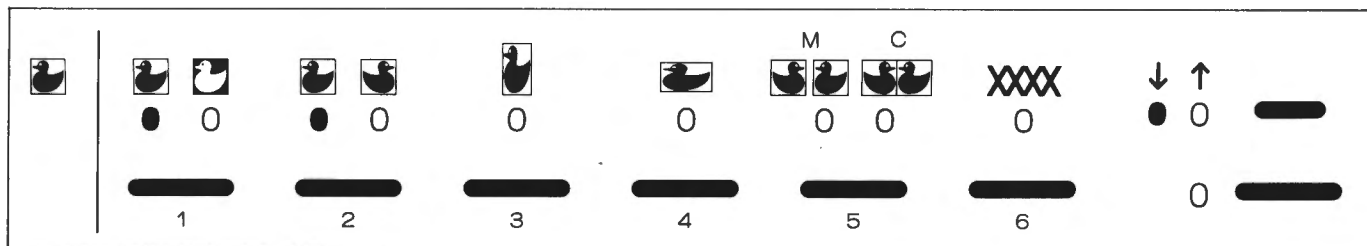

A single picture of a duck at the left end shows the pattern on the Pattern Card, the normal way it is knitted, so you can compare that picture with the pictures by the Pattern Switches (the function switches) and see what the effect of that switch is.

The lights below the pictures show whether that particular function is on or not. By pressing the switch, the light changes, comes on or goes off. When you switch on the Pattern Controller, the left lights of the Pattern Switches 1, 2 and the Direction Switch come on. So press on each switch, according to your need. You can use 2 or more switches together.

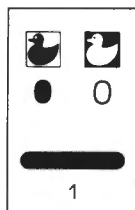

Pattern Switch 1 (Colour Normal/Reverse)

Switch 1 shows the duck either like the sample duck to the left, or with the colours changed round.

Either the left or right light always is on. They determine whether the machine reads the black area or white area of the Pattern Card.

If the left light is on;

Fair Isle will knit a pattern as you see it on the Pattern Card. The machine knits the white area of the Pattern Card (background) with the yarn in Yarn Feeder ① and the black area (pattern) with the yarn in Yarn Feeder ②.

If the right light is on;

Fair Isle will knit a pattern with the colours reversed. The machine knits the white area with the yarn in Yarn Feeder ② and the black area with the yarn in Yarn Feeder ①.

The right light is used mainly for Tuck and Slip Stitch patterns. When the right light is on, the machine knits white area and tucks or slips the black area. You must use the left light for knitting Single Motif.



(Left light ON)

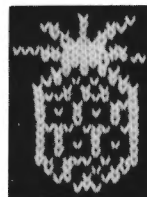

(Right light ON)

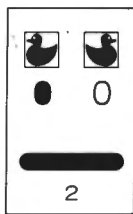

Pattern Switch 2 (Direction Normal/Reverse)

Either the left or right light always is on and indicates which direction a pattern will face.

If the left light is on;

The pattern knits as you see it on the Pattern Card, on the purl side of the knitting.

If the right light is on;

The pattern faces the other way.

If you want the knit side to be the same as the Pattern Card, have the right light on. (In order to knit letters correctly, have the right light on.)



(Left light ON)



(Right light ON)

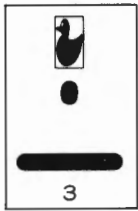

Pattern Switch 3 (Vertical Expansion)

Switch 3 has only one picture and the duck is drawn the same width but twice as tall.

If the light is on;

Any pattern will be knitted twice as tall. There will be two rows of knitting for each row on the Pattern Card. (Press this switch when the Carriage is on the side, ready to start knitting.)

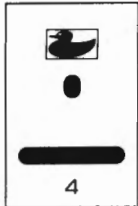
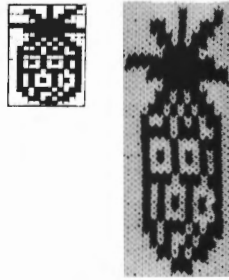

Pattern Switch 4 (Horizontal Expansion)

Switch 4 also has only one picture, and the duck is shown normal height but twice as wide.

If the light is on;

Any pattern will be knitted twice as wide. There will be two stitches for each one on the Pattern Card.

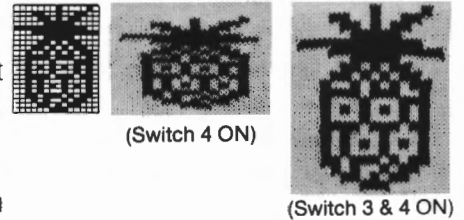

You can use switches 3 and 4 together to get a pattern twice as tall and twice as wide as the pattern drawn on the Pattern Card.

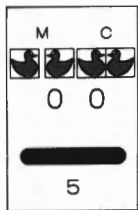

Pattern Switch 5 (Mirror Image)

Switch 5 has two pictures, both with two ducks facing each other. Both these functions give a "mirror image" effect, but slightly differently. If either of these lights is on, the pattern will knit facing one way, then the other way, then the first way again, all across the knitting. These functions are distinguished by letter "M" and "C". M means "Mirror" and C means "Chevron".

The difference is easiest to understand if we use a very simple four stitch pattern. We'll call the stitches 1-2-3-4.

If the left light is on (Mirror);

The pattern will knit 1-2-3-4-4-3-2-1-1-2-3-4-4-3-2-1 and so on. The pivotal stitches (both edges of the pattern) repeat.

If the right light is on (Chevron);

The pattern will knit 1-2-3-4-3-2-1-2-3-4-3-2-1 and so on. The pivotal stitches (both edges of the pattern) do not repeat.

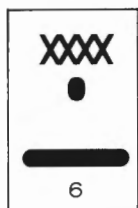
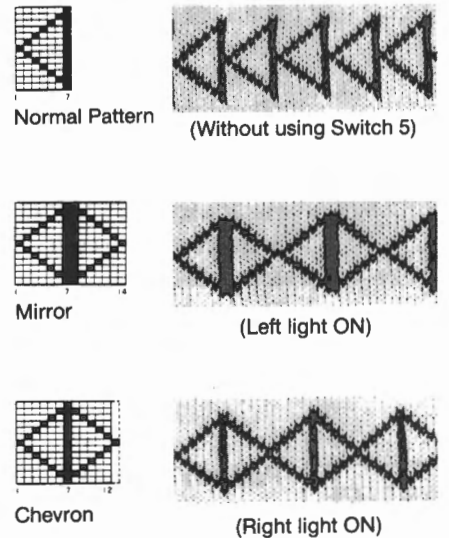

Pattern Switch 6 (Jacquard)

Switch 6 is used only when knitting Double Jacquard with the use of the Ribber. (Refer to pages 94 ~ 95.)

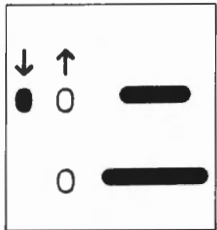

Direction Switch

The Direction Switch is used to change the feeding direction of the Pattern Card. It has two lights.

If the left light is on;
The Pattern Card will be fed downwards.

If the right light is on;
The Pattern Card will be fed upwards.

But normally this direction will be handled completely automatically by the instruction columns of the Pattern Card.

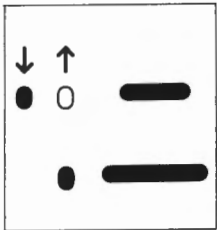

Inspection Switch

The Inspection Switch is used to feed the Pattern Card, or to stop feeding. It is very important and you'll use it a lot. It has only one light. Press the switch to have the light on.

If the light is on;
The Pattern Card will come up by 10 rows and stop. It won't be fed even if the Carriage is moved.

If the light is off;
The Pattern Card will be fed down into the Card Reader by 10 rows and the pattern on the first row will be read by the scanners. (When the pattern is read, you'll hear the scanning sound.)
The Pattern Card will be succeedingly fed responding to the movement of the Carriage.

PATTERN WIDTH INDICATOR

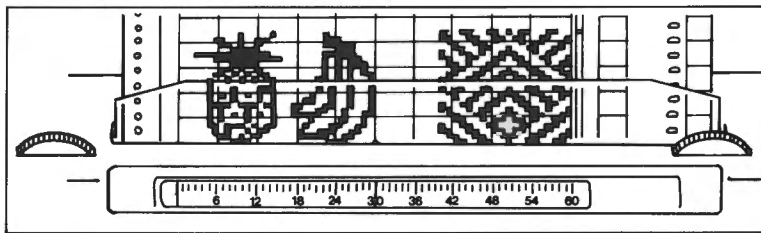

The Pattern Width Indicator has two red pointers (left and right). Each of the pointers is set by turning the Left or Right Pattern Dials, and will pick out a full pattern or a part of the pattern.

The minimum number of stitches which you can pick out by the red pointers is two.

Before setting the red pointers, press the Inspection Switch to have the light on.

The samples below show the patterns with different positions of the Pattern Width Indicator.

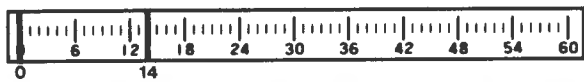
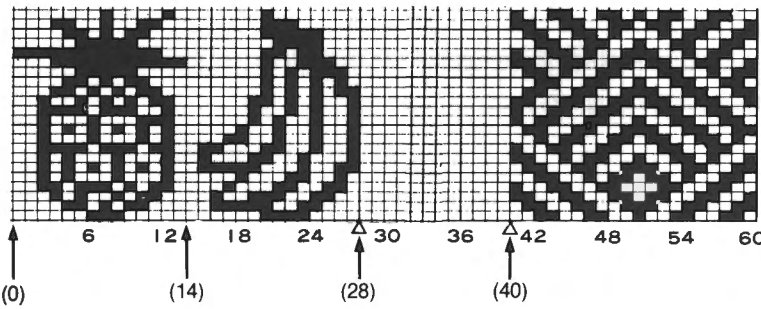

Set the left red pointer to (0) on the scale and the right to (14).

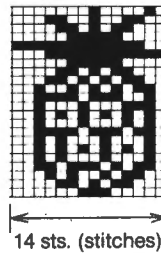
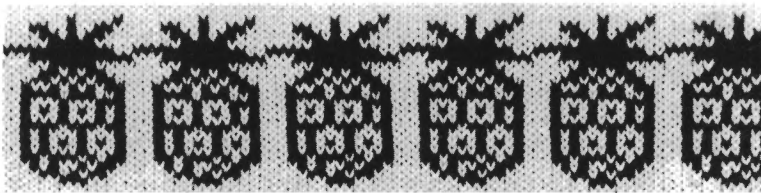

14 stitches from the 1st to the 14th on the Pattern Card will be knitted.

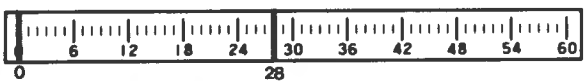

Set the left pointer to (0) and the right to (28).

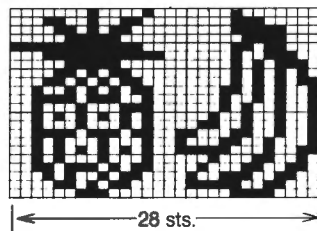
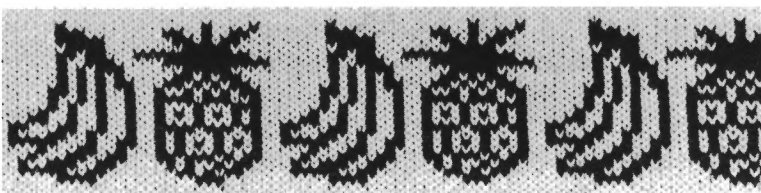

28 stitches from the 1st to the 28th will be knitted.

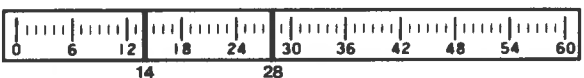

Set the left pointer to (14) and the right to (28).

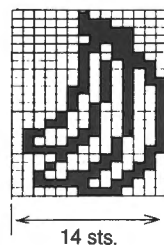
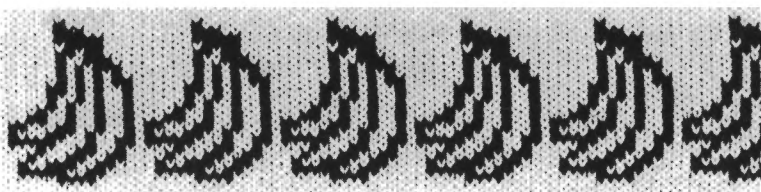

14 stitches from the 15th to the 28th will be knitted.

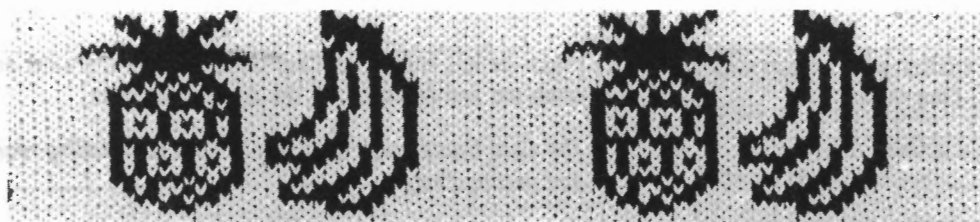
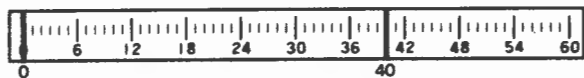

Set the left pointer to (0) and the right to (40).

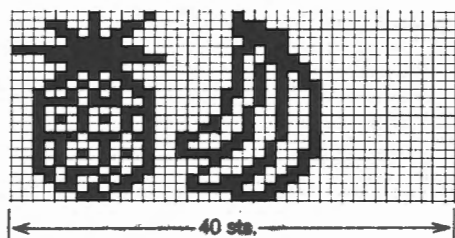

40 stitches from the 1st to the 40th will be knitted.

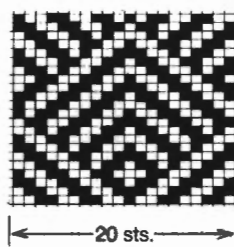
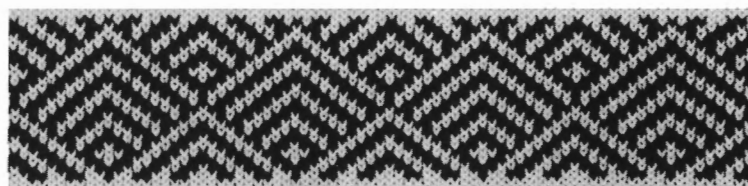
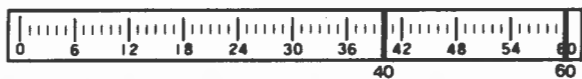

Set the left pointer to (40) and the right to (60).

20 stitches from the 41st to the 60th will be knitted.

The samples above and the ones on the previous page are knitted with the right light of the Pattern Switch-2 ON.

SETTING THE PATTERN CARD

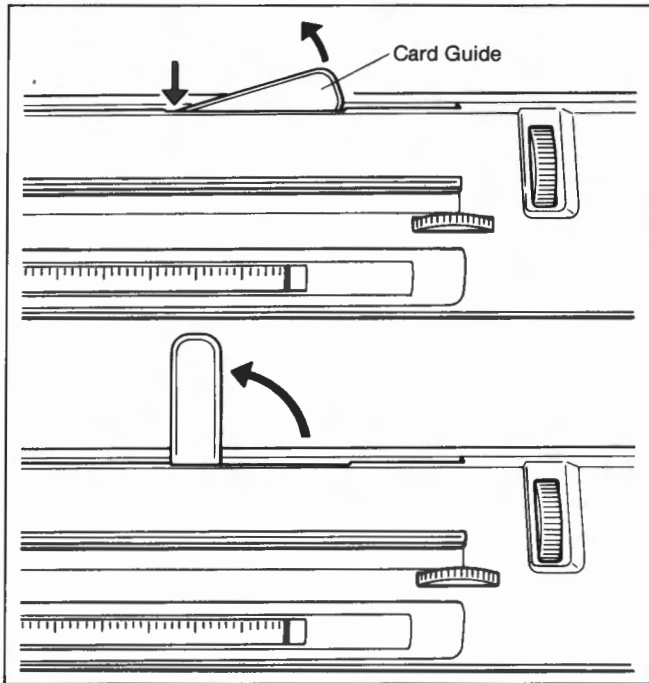

1. Press the left end of the Card Guide to have the other end come out and pull it out in the arrowed direction.

The Card Guide stops the Pattern Card from rolling round and getting caught.

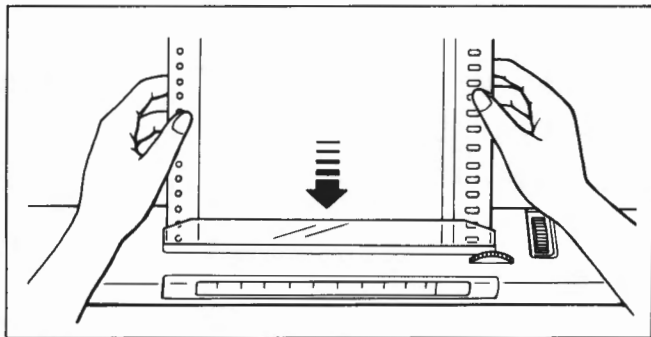

2. Press "ON" the Inspection Switch. (Light comes on.)

3. Hold the Pattern Card in both hands and push it down into the Card Slot behind the plastic card cover.

Check that the horizontal lines on the Pattern Card parallel the Card Slot.

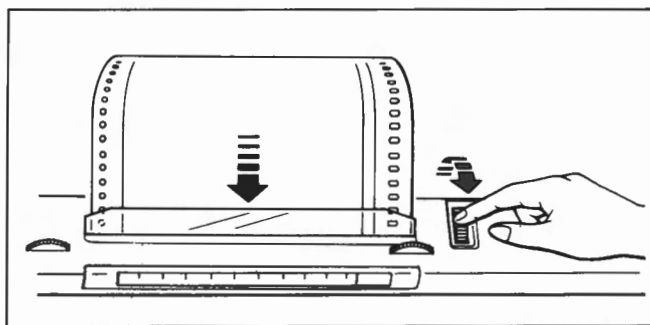

4. Turning the Card Dial towards you, insert the Card into the Slot.

5. Set the Pattern Width by turning the Pattern Dials.

6. Turn the Card Dial towards you until the first row of the pattern is just visible above the Slot.

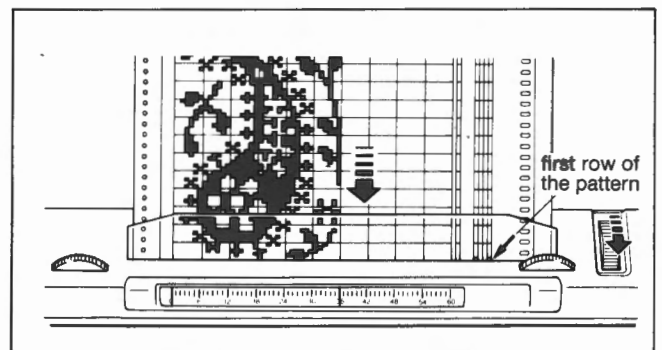
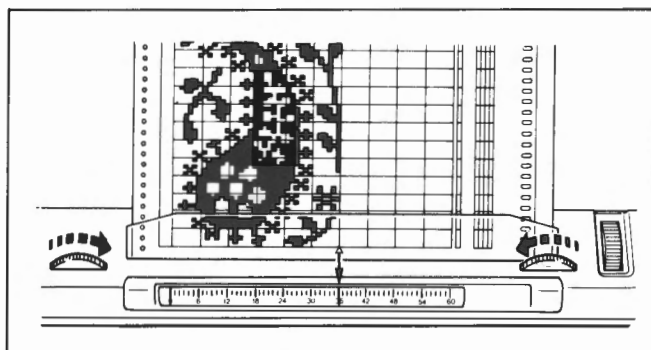

PRECAUTION IN PATTERN KNITTING

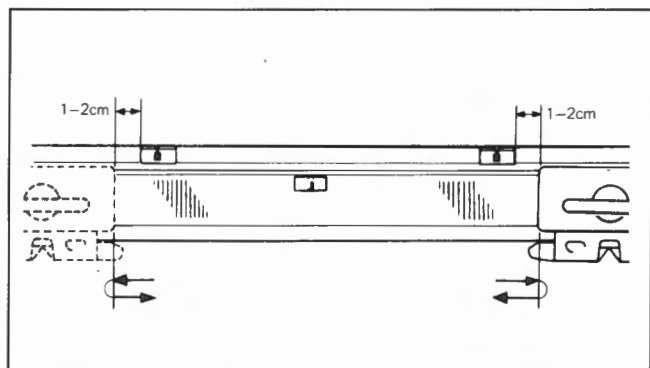

Carriage operation

Move the Carriage until it clears both Point Cams before returning it. If you return the Carriage before clearing the Point Cam, the pattern will be knitted incorrectly.

To correct the memory, turn off the Controller and then follow the instructions given under "To turn off the Controller during knitting" on page 48.

Knitting speed must not exceed the reading speed of patterns. Listen for the scanning sound as you knit.

If the Carriage is moved back and forth too quickly, it may cause the reader to skip a pattern row.

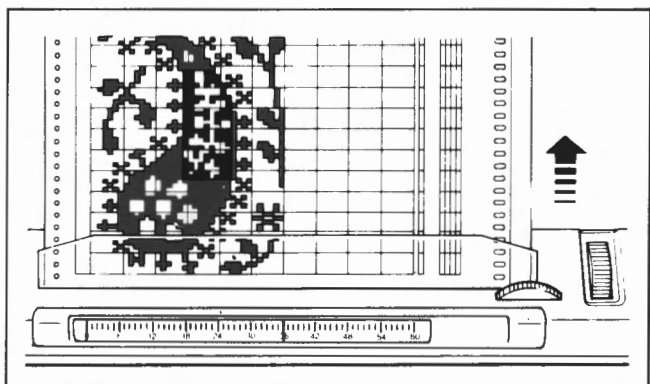

Card returning

When the last row of the pattern has been read, the buzzer sounds once. When the last row of the pattern has been knitted, the Pattern Card returns to the first row of the pattern in a quick motion.

While the Card is in quick motion, hold the Carriage outside the Point Cams till the Card stops, and reading the pattern is completed.

If you move the Carriage before the Card returns, the machine will beep out a warning and the pattern will be knitted incorrectly.

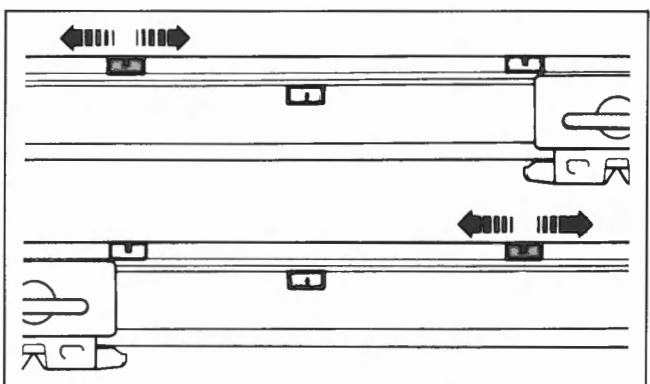

Point Cams and Needle-1 Cam

You may move the Point Cam on the opposite side to the Carriage before knitting the next row, you may never move the Point Cam on the Carriage side during pattern knitting. (If the Point Cams are away from the edge of the knitting as a result of decreasing, make sure the Carriage passed the Point Cams.)

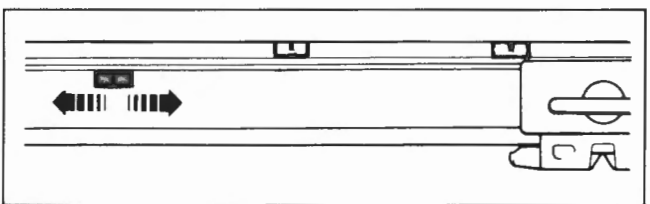

Do not move the Needle-1 Cam.

If the Needle-1 Cam is left outside of the Point Cam as a result of garment shaping, leave it in its original position, but ensure that the Carriage passes it on each row.

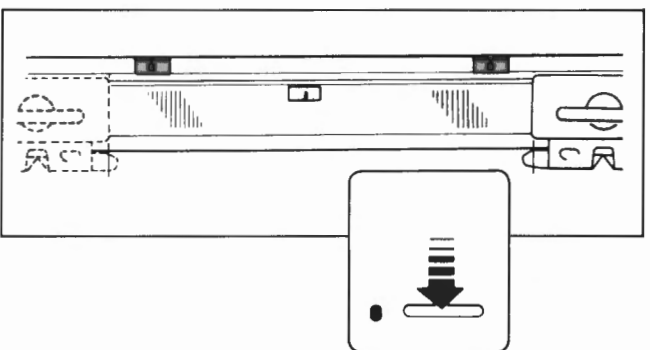

Inspection Switch and Pattern Switches

Don't press the Inspection Switch and the Pattern Switches when the Carriage is between the Point Cams.

If you press them in this situation, some of them won't work.

To press the Inspection Switch and the Pattern Switches, place the Carriage outside of the Point Cams (on the left or right side).

FAIR ISLE (KNIT-IN)

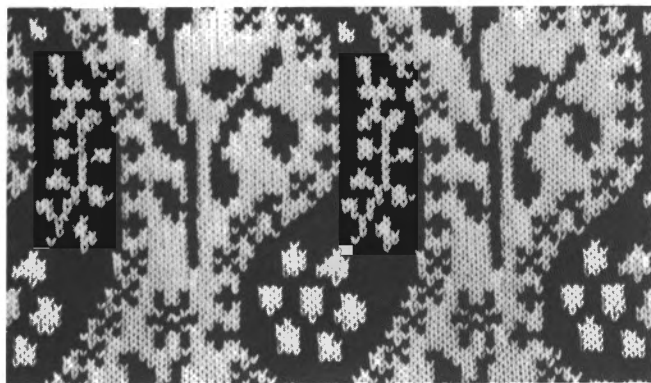

Two yarns of different colours are knitted simultaneously and form patterns on the knitting.

The sample is knitted with the Pattern No.8—(44).

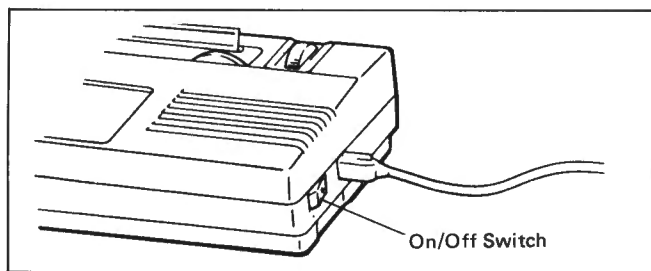
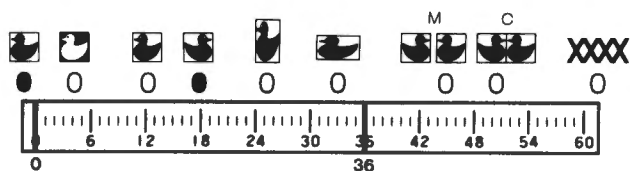

PROCEDURE FOR PATTERN KNITTING

- 1 After connecting the Pattern Controller to the machine, switch on the Pattern Controller.

The Controller will beep. This tells you that all is well.

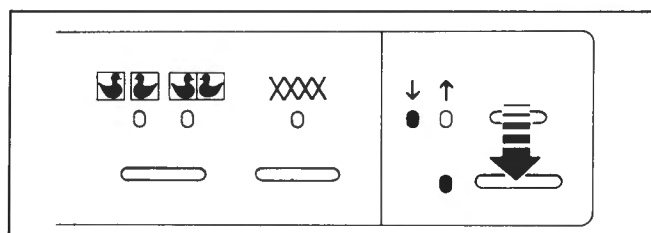

- 2 Press "ON" the Inspection Switch. (The light comes on.)

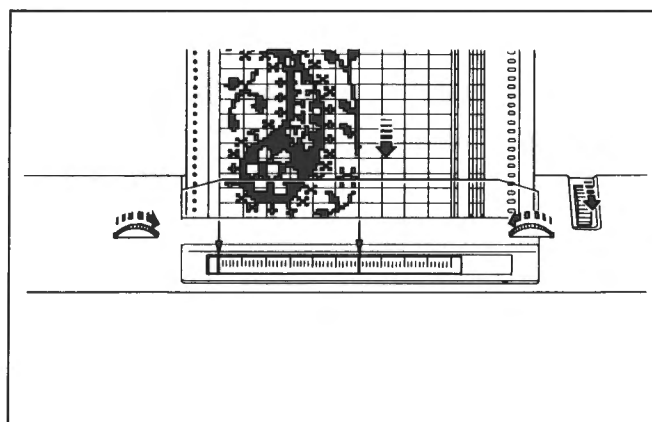

- 3 Insert the Pattern Card into the Card Slot. (Refer to page 30.)

Set the pattern width by turning the Pattern Dials as shown below the picture.

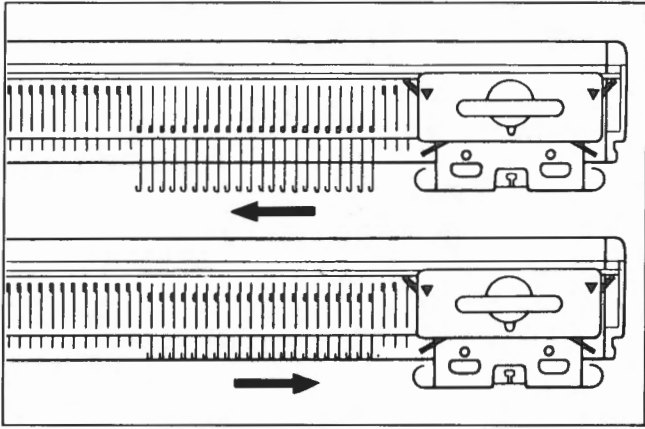

- 4 Push the required number of needles to D position.

Set the Carriage as shown below.

Cam Lever..... ○ (STOCKINET)
 Russel Levers..... || (both)
 Side Levers..... ▼ (both)
 Weaving Knobs..... ○ (both)

Move the Carriage across the needles to align them in B position. (In case knitting has already been started, this step can be skipped.)

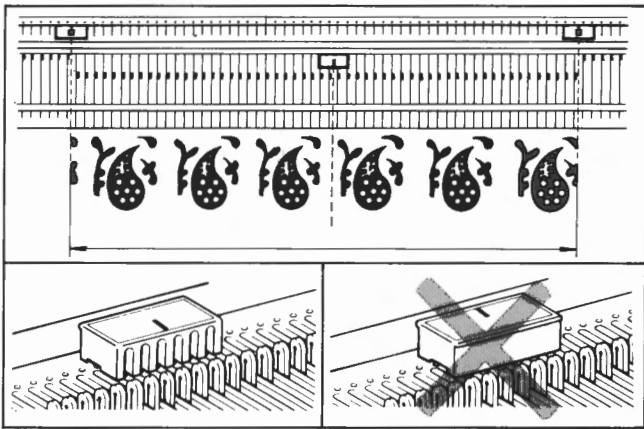

- 5 Set the Point Cams at both ends of the needles in B position so that their red marks come to the outside of the end needles.

Set the Needle-1 Cam at the center of Needle Bed.

Set the Needle-1 Cam into the holes at the back of the Needle Bed.

The Needle-1 Cam must be placed behind the needles, with the red line facing you.

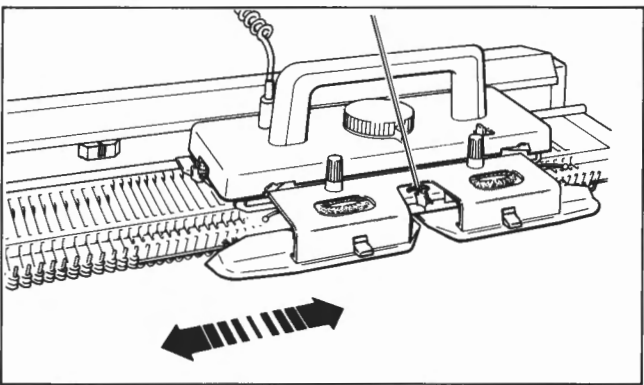

- 6 Thread the main yarn through the Auto-Tension and into Yarn Feeder ①.

Cast-on and knit several rows in Stockinet, finishing with the Carriage on the right. (Refer to pages 13 ~ 14.)

If there is already knitting on the needles, move the Carriage across twice without knitting, by using the Release Lever. This is to enable the machine to memorize the settings of the Point Cams, the Needle-1 Cam.

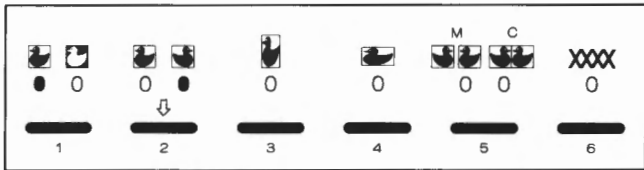

- 7 Press the Pattern Switch as shown below the picture on page 32.

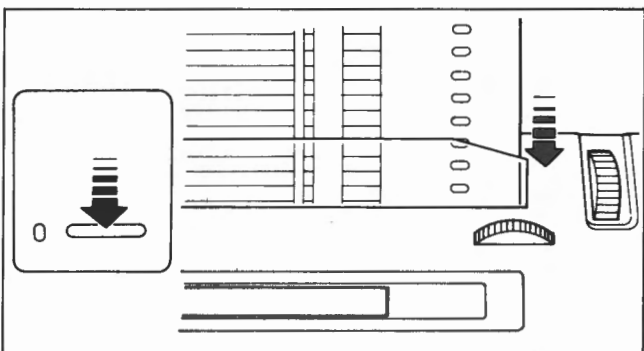

- 8 Press "OFF" the Inspection Switch. (The light goes off. The Pattern Card is fed by 10 rows downwards and the pattern on the first row is read.)

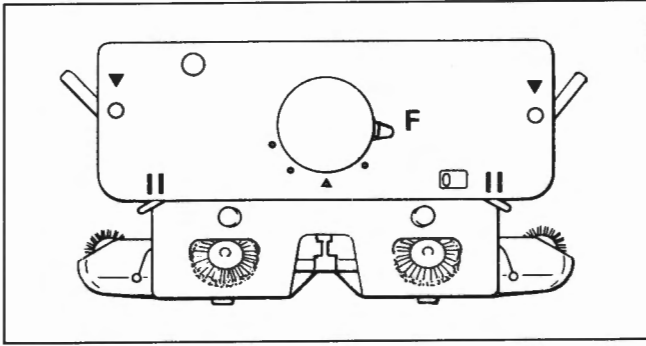

② Set the Carriage as shown below.

Cam Lever..... F (Fair Isle)
 Russel Levers..... II (both)
 Side Levers..... ▼ (both)
 Weaving Knobs..... O (both)

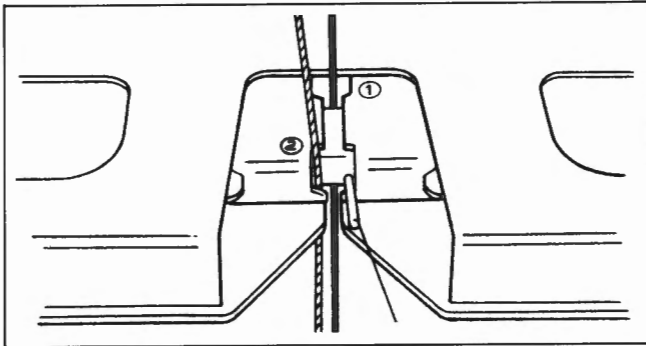

Thread the contrast yarn through the Auto-Tension and into Yarn Feeder ②.

PREPARATORY STEPS FOR PATTERN KNITTING HAVE BEEN COMPLETED. START KNITTING THE PATTERNS.

WHILE KNITTING THE PATTERN

To make both edges of the knitting neat, push up the first needle to D (or C in partial knitting) position before knitting the next row.

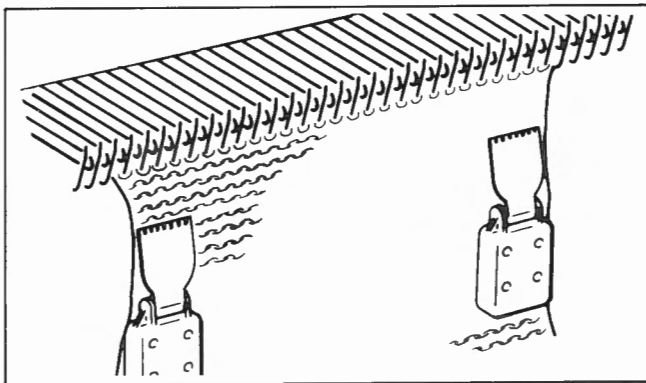
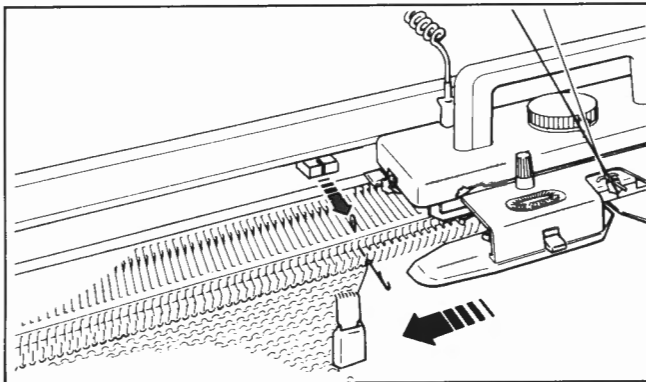

Hang the Claw Weights on both sides of the knitting. (Move them up as knitting progresses.)

SLIP STITCH

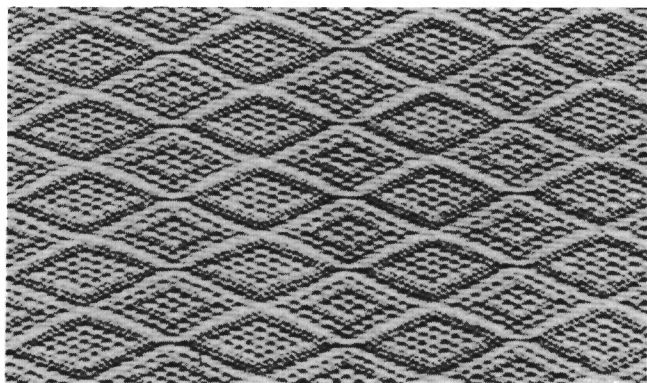

A selected needle remains inactive and the yarn passes in front of the needle. Non-selected needles knit Stockinet.

The sample is knitted with the Pattern No.2-(19).

Before knitting this stitch pattern, follow the Preparatory Steps ①, ②, ③, ④, ⑥, ⑦, ⑧ given on page 32 ~ 33.

The Steps ⑤, ⑨ are a little different. So follow the instructions below.

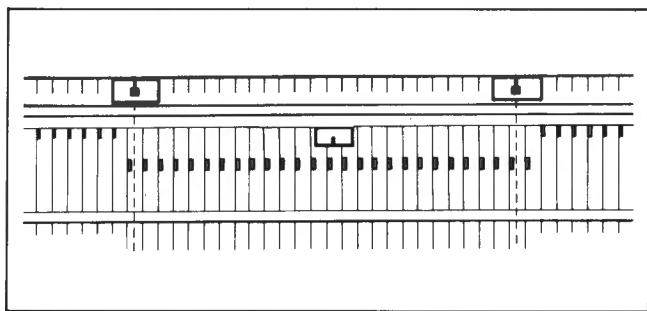
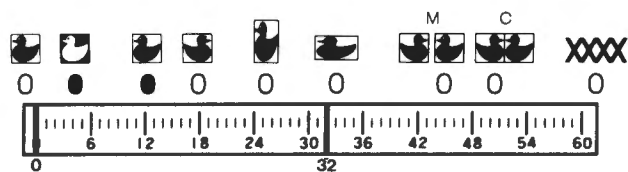

Step ⑤

Set the Point Cams one stitch in from the edge of the knitting to prevent the edge stitches from knitting incorrectly.

Set the Needle-1 Cam at the center of the Needle Bed.

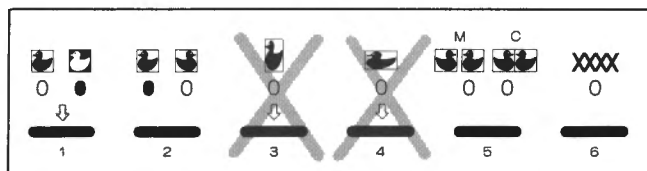

PRECAUTION

The Pattern Switch-1 must be pressed to have the RIGHT light on.

Don't use the Pattern Switches 3 and 4.

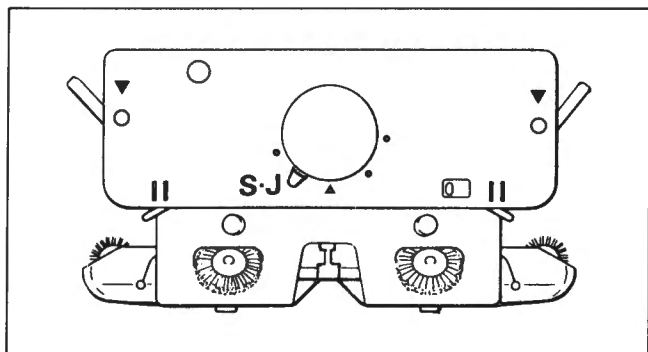

Step ⑨

Set the Carriage as shown below.

Cam Lever..... **S** (Slip)
 Russel Levers..... **II** (both)
 Side Levers..... **▼** (both)
 Weaving Knobs..... **O** (both)

It is recommended to set the Stitch Dial 1 number higher than the other stitch types.

*Hang the Claw Weights and the Wide Claw Weights.
 (Refer to page 36.)*

TUCK/SLIP STITCH PATTERN IN COLOURS

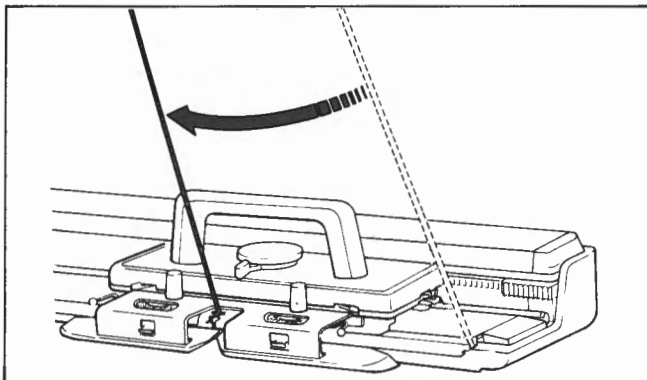
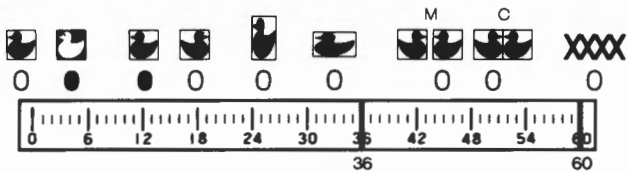
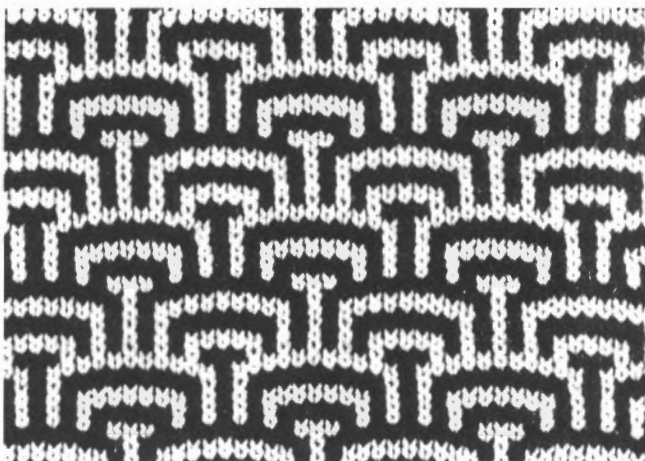
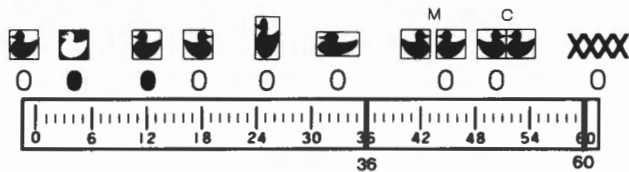
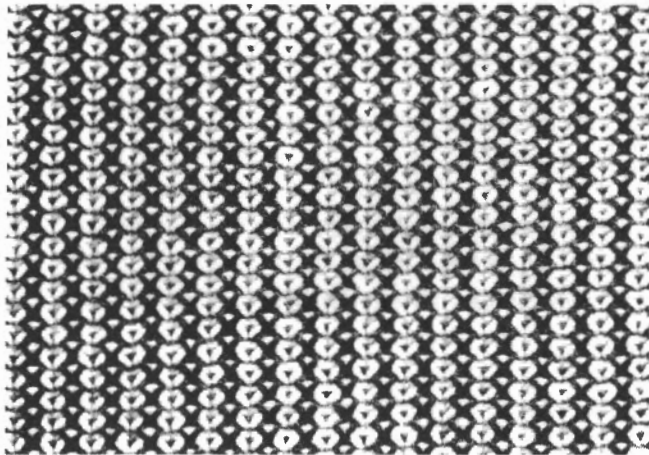

Tuck Stitch patterns and Slip Stitch patterns can be knitted using yarns of different colours.

The sample on top shows the pattern in Tuck with the Pattern No.1-(2) and the second picture shows Slip with the Pattern No.1-(12).

The Preparatory Steps for knitting multi-coloured Tuck and Slip stitches are the same as for single colour work. But only the pattern width is different. So set the Pattern Width Indicator as shown below each sample.

WHILE KNITTING THE PATTERN

Place colour 1 into Yarn Feeder ① and knit first 2 rows.

Exchange colour 1 for colour 2 and knit 2 rows.

Continue to knit exchanging colours every 2 rows. (Exchange the yarns in the same way as for "Knitting Stripe Pattern" on page 17 ~ 18.)

SINGLE MOTIF



A single pattern in Fair Isle (Knit-in) can be knitted at any position on the knitting.

The sample is knitted with the Pattern No.10-(49).

Before knitting this stitch pattern, follow the Preparatory Steps ①, ②, ③, ④, ⑥, ⑦, ⑧, ⑨ given on page 32 ~ 33. The Step ⑤ is a little different. So follow the instructions below.

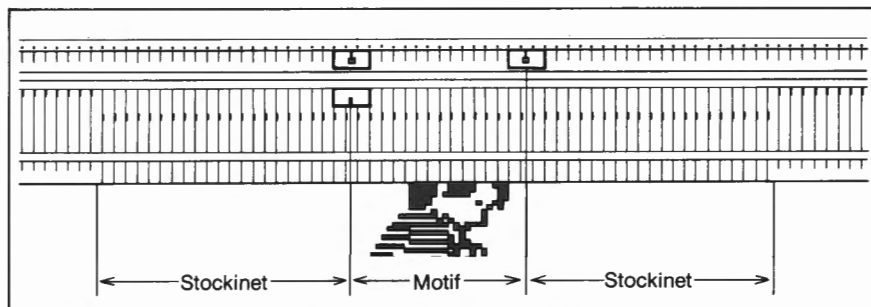
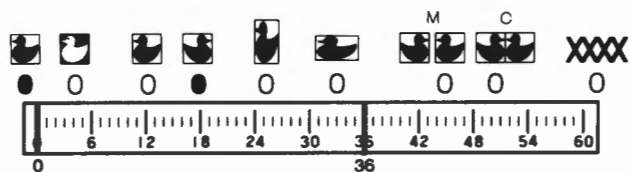

Step ⑤

The sample shown here has the pattern width of 36 stitches. Set the Point Cams 36 needles apart, and align the red line of the Needle-1 Cam with the red line of the left Point Cam, as shown in the diagram.

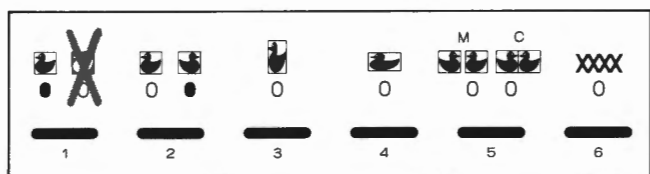

When knitting in Single Motif pattern, the left light of the Pattern Switch-1 must be lit.

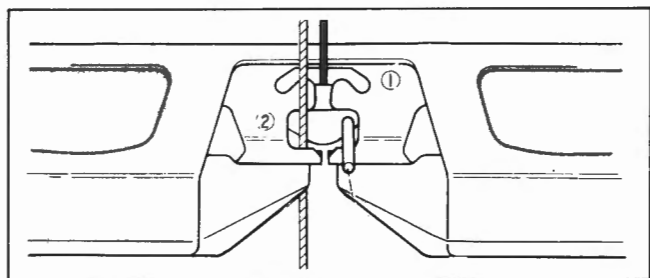

Place the contrast yarn into Yarn Feeder ② in the same way as for Fair Isle.

(Setting the Carriage is the same as for Fair Isle.)

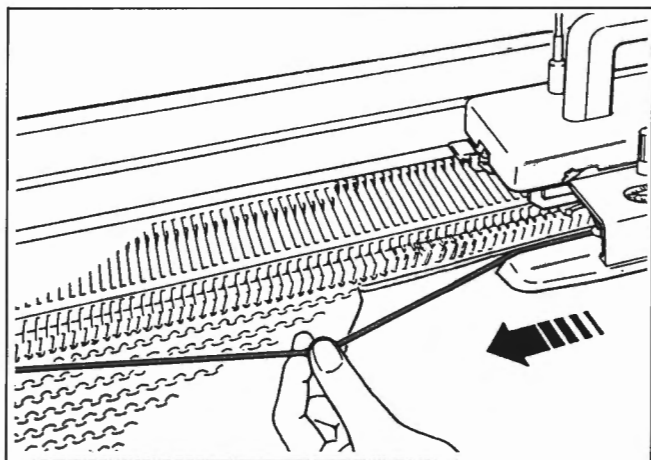

WHILE KNITTING THE PATTERN

To separate the contrast yarn from the ground yarn, hold the contrast yarn as shown opposite, before knitting the next row.

And release the yarn immediately after the Carriage comes to the edge knitting needles. If you don't do so, the yarn will slack at the edge of the Single Motif pattern.

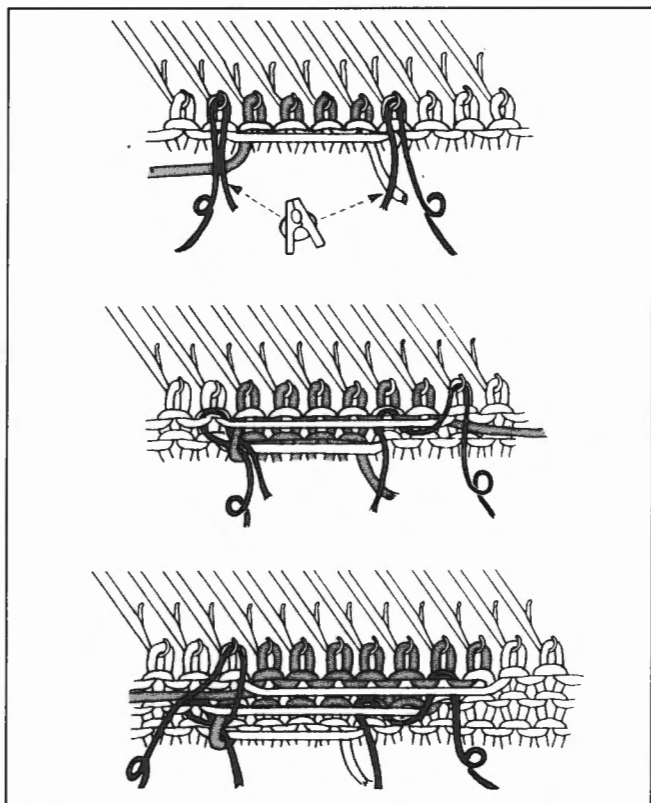

To prevent separation of the contrast yarn from the ground yarn at the edge of the Single Motif pattern, follow the procedure below.

- ① Prepare two pieces of yarn, 60 ~ 70cm. long, cut from the ground yarn.
- ② Place the yarns in the hooks of the needles immediately adjacent to the last needles knitted in the contrast yarn at both edges of the Single Motif. It is advisable to clip the short ends of the yarns together.
- ③ Knit the next row, and place the yarn in the hook of the needle immediately adjacent to the Single Motif on the Carriage side.
- ④ Knit the next row, and place the yarn in the hook of the needle adjacent to the Single Motif on the Carriage side.
- ⑤ Repeat the above steps on each row on the Carriage side.

To knit Stockinet after the Single Motif, set the Cam Lever to **O**. Press "ON" the Inspection Switch and knit.

Hang the Claw Weights on the knitting at the position corresponding to the edges of the Single Motif pattern.

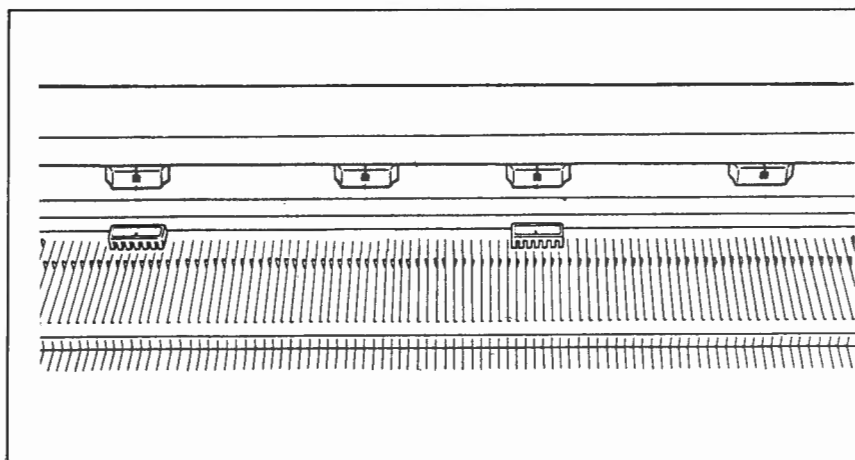

You can knit two isolated Motifs by using two sets of Point Cams and two Needle-1 Cams.

Knit them in the same way as for the Single Motif. But set two sets of Point Cams and Needle-1 Cams as shown opposite. (You can leave space as you want between each set.)

Use one Needle-1 Cam for each set of Point Cams.

WEAVING

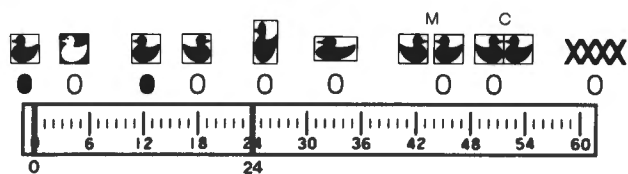
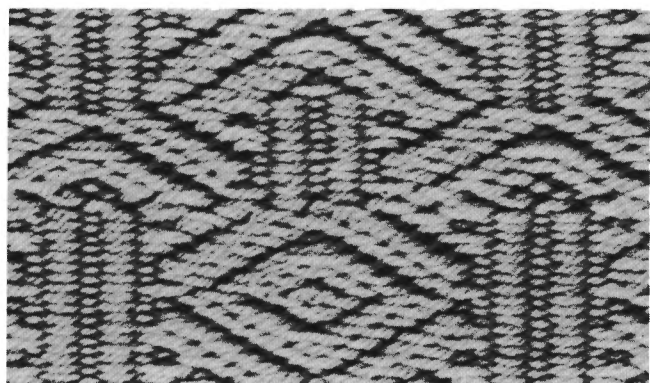

By passing fancy yarn or different materials (hereafter called weaving yarn) between the Stockinet stitches on purl side, a pattern is made on the surface of the knitting.

The sample is knitted with the Pattern No.1-(11).

Before knitting this stitch pattern, follow the Preparatory Steps ① ~ ⑧ given on page 32 ~ 33.

The Step ⑨ is a little different. So follow the instructions below.

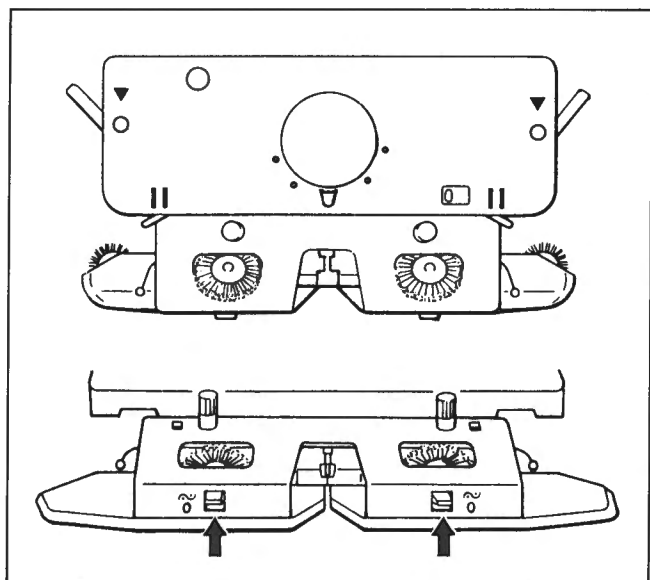

Step ⑨

Set the Carriage as shown below.

Cam Lever..... **O** (Stockinet)
 Russel Levers..... **II** (both)
 Side Levers..... **▼** (both)
 Weaving Knobs..... **∞** (both)

(Push up the Weaving Knobs to set them to ∞.)

Set the Stitch Dial 1 number higher than for Stockinet knitting.

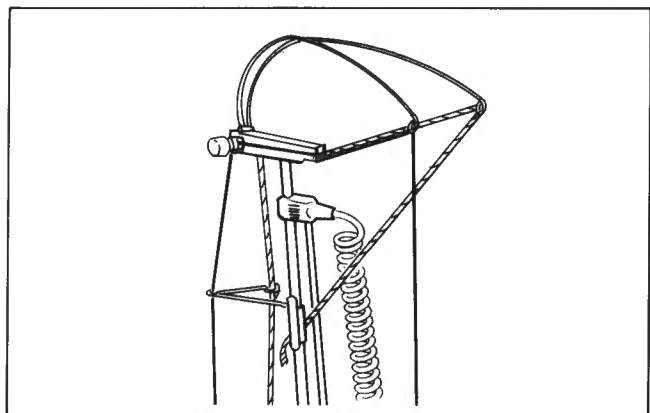

Thread the weaving yarn into the Auto-Tension and hook it into the Yarn Clip.

Hang the Claw Weights on both sides of the knitting.

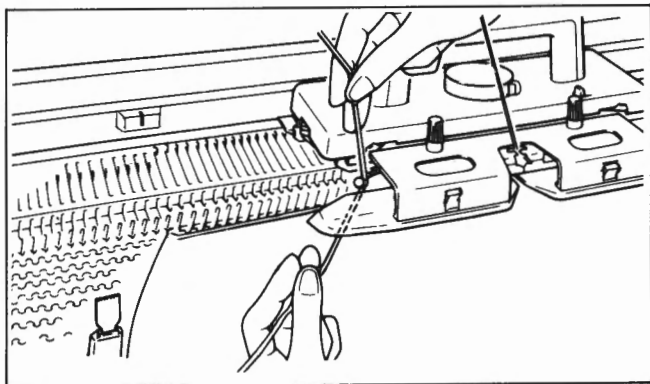

To start pattern knitting, follow the procedure below.

Take the thick yarn from the Clip on the Yarn Rod, and place it in the Weaving Yarn Holder on the leading side of the Carriage.

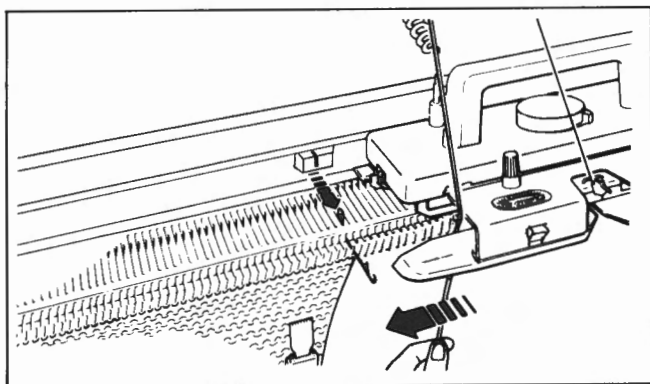

Holding the weaving yarn under the Arm, push the first knitting needle to D position, and then move the Carriage to the other side.

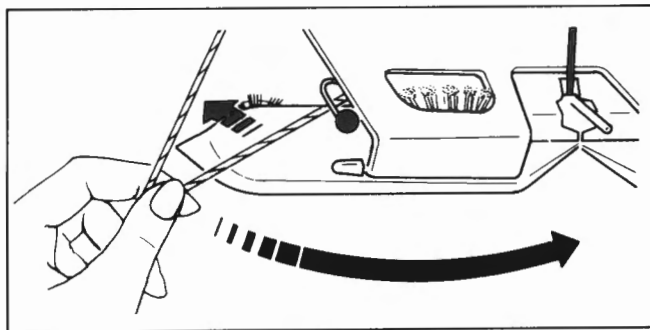

Before knitting the next row, remove the weaving yarn from the Weaving Yarn Holder.

Guide the weaving yarn under the Arm to the other side of the Carriage.

At this step, push the Carriage in the original direction to free the weaving yarn from the brushes under the Arm.

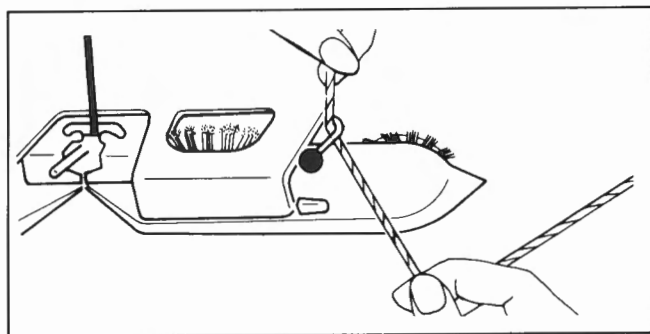

Place the weaving yarn inside the Holder on the leading side of the Carriage.

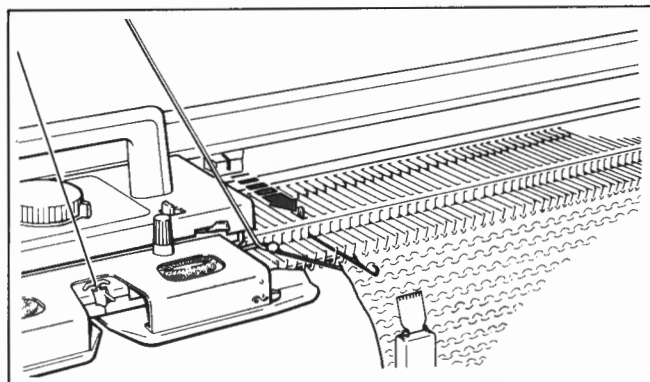

Push the first needle to D position for Stockinet (or C position in partial knitting) and move the Carriage to the other side of the Needle Bed.

Repeat in the same manner, placing the weaving yarn into the Holder on the leading side before knitting the next row.

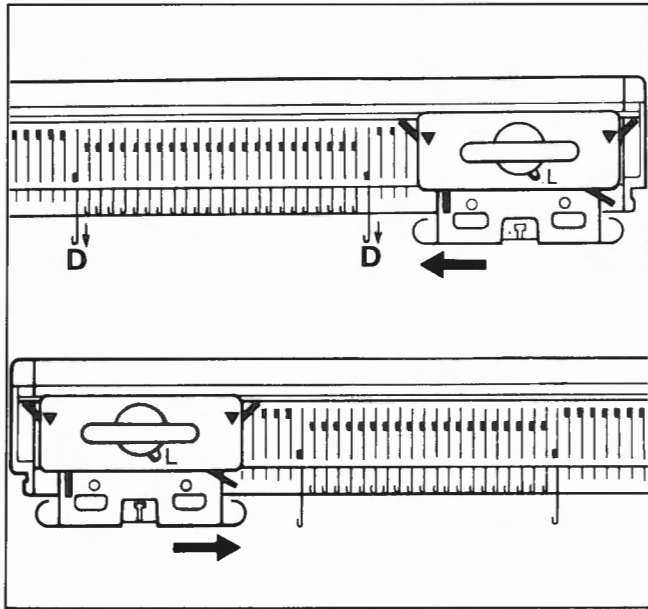

WHILE KNITTING THE PATTERN

Push one needle at both edges of the knitting to D position.

Knit from right to left. (The end needles will not be knitted.)

Knit from left to right. (The end needles will be knitted back to B position.)

Knit the required number of rows pushing the end needles to D position when the Carriage is on the right.

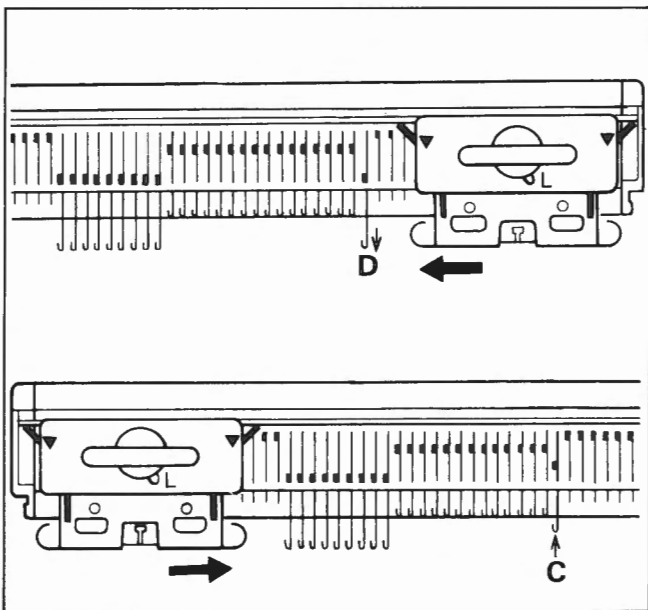

When you do partial knitting, set both Russel Levers to **I**, push one needle on opposite side of resting needles to D position to knit from right to left, and push back the needle to C position to knit from left to right.

HELPFUL HINTS

CONTENTS

	page
IF YOU WANT TO	46
To unravel the knitting on the machine	46
To change the pattern controls or the other settings of the machine during pattern knitting	47
To turn off the Controller during knitting	48
To knit Stockinet during pattern knitting	48
To knit a selected pattern row repeatedly	48
To check the knitted row with the pattern on the Pattern Card	48
WHAT TO DO IF	49
If the Carriage has jammed	49
If a stitch has dropped during knitting	50
If incorrectly knitted	51
If the warning buzzer sounds during knitting or if you notice that you are knitting incorrectly	52
If the Carriage has been removed from the Needle Bed	53
If the end stitches are not stable or if the Carriage is heavy to operate	53
If a needle has been damaged	54

IF YOU WANT TO

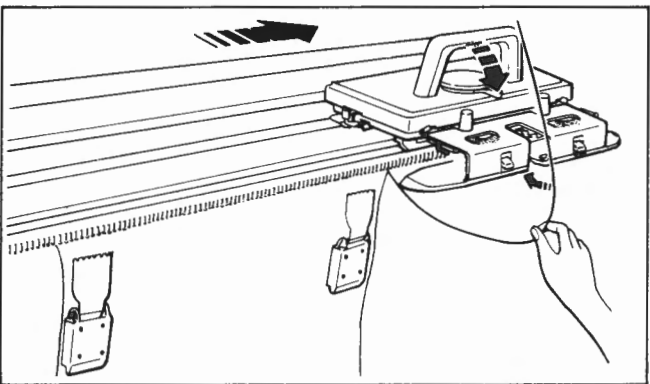
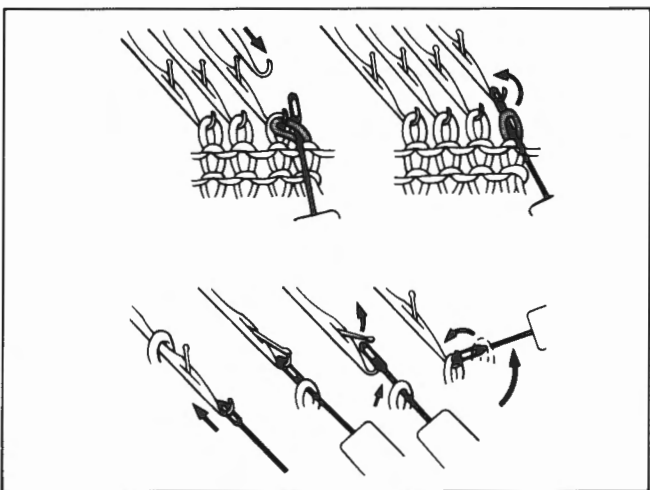
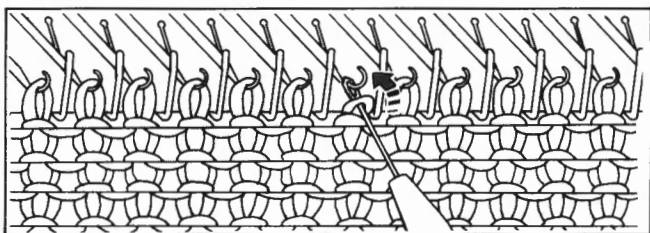
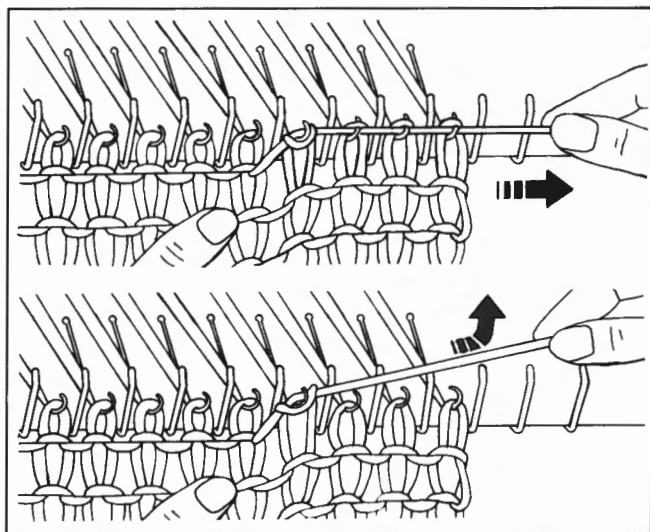

To unravel the knitting on the machine

1. Hang the Claw Weights on both edges of the knitting.
2. Holding the knitting downwards, pull the yarn out, and the row gets tight.
3. Lift the yarn upwards and very slightly backwards. The stitches of previous row slide back into needle hooks.

Ensure all stitches are in the needle hooks.

If some of stitches are not in needle hooks, place them into the hooks using the Transfer Tool.

Repeat the above procedure until the required number of rows have been unravelled.

4. Align the needles in B position.

IF THE KNITTING HAS BEEN SHAPED IN DECREASE OR PARTIAL KNITTING:

(The knitting with decreased edge)

On the row of decrease, the end needle has two stitches, place one stitch back to its original needle.

(In the course of partial knitting)

Replacing the stitches in the needle hooks, push back the needles in D position to B position using Transfer Tool.

5. To continue knitting, pull the unravelled yarn back towards the yarn ball at the back of the Tension Rod, move the Carriage to the side of the yarn end using Release Lever, adjust the Row Counter, and replace the yarn in the Yarn Feeder.

If the Pattern Card is in use, return it by the same number of rows as you have unravelled. (Refer to pages 51 ~ 52.)

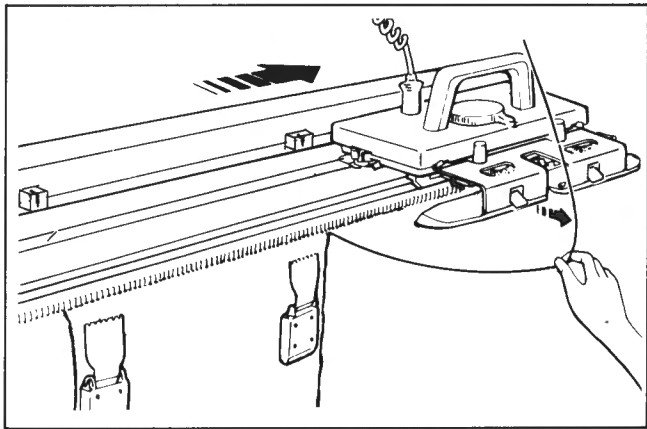

To change the pattern controls or the other settings of the machine during pattern knitting

Before changing the Pattern Controls or the other settings of the machine, make sure the Carriage is outside of the Point Cams. Remove the yarn from the Yarn Feeder.

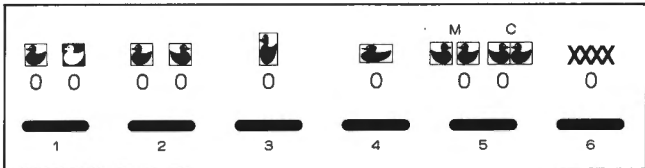

TO RE-SET THE PATTERN SWITCHES

Press "ON" or "OFF" the selected Pattern Switch, and continue knitting.

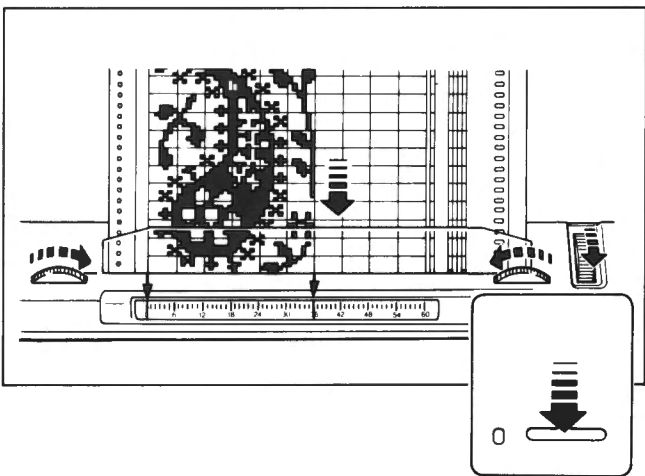

TO CHANGE THE PATTERN WIDTH INDICATOR OR THE PATTERN CARD

Press "ON" the Inspection Switch. (Light is on.)

Re-set the Pattern Width Indicator, or exchange the Pattern Cards.

Press "OFF" the Inspection Switch and start knitting.

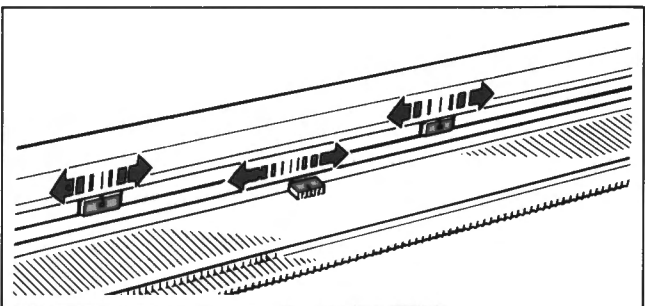

TO CHANGE THE POSITIONS OF BOTH POINT CAMS AND/OR NEEDLE-1 CAM

Press "ON" the Inspection Switch (light is on). Move the Point Cams and/or Needle-1 Cam to the new positions.

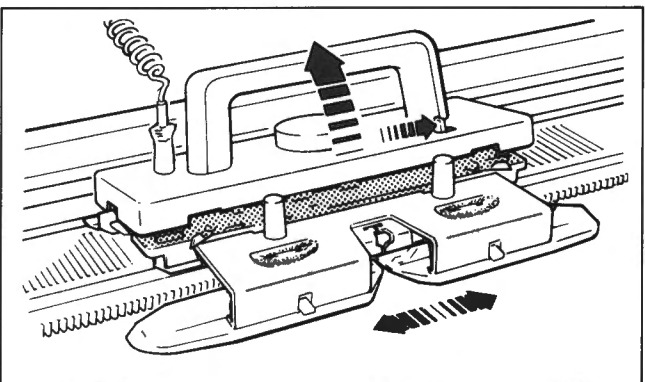

To memorize the new positions of the Point Cams and/or the Needle-1 Cam, move the Carriage twice without knitting (by pushing the Release Lever).

Re-set the Carriage to the original setting.

Press "OFF" the Inspection Switch and continue knitting.

You can change the position of the Point Cam on the side opposite the Carriage, without moving the Carriage to memorize it. (Refer to page 31.)

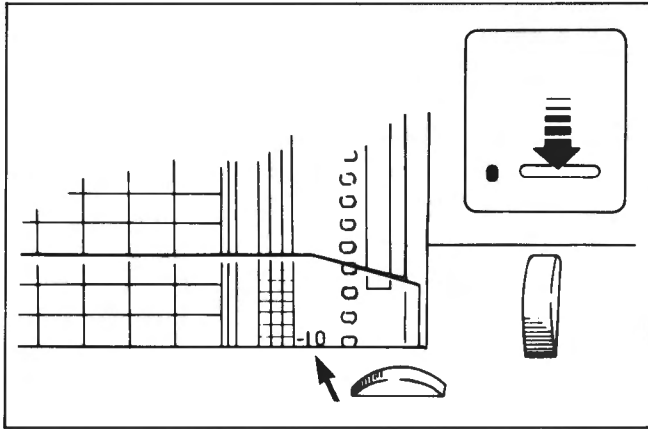

To turn off the Controller during knitting

With the Inspection Switch on, note the row number shown at the Card Slot before turning off the Controller.

To start knitting again,

1. Turn on the Controller, and press "ON" the Inspection Switch.
2. Move the Carriage twice to memorize the positions of the Point Cams and Needle-1 Cam.
3. Set the Pattern Card so that the noted row number is above the Card Slot. (Inspection Switch light is on.)
4. Re-press the same Pattern Switch as the original setting.
5. Press "OFF" the Inspection Switch to read the row to be knitted next. (Light is off.)

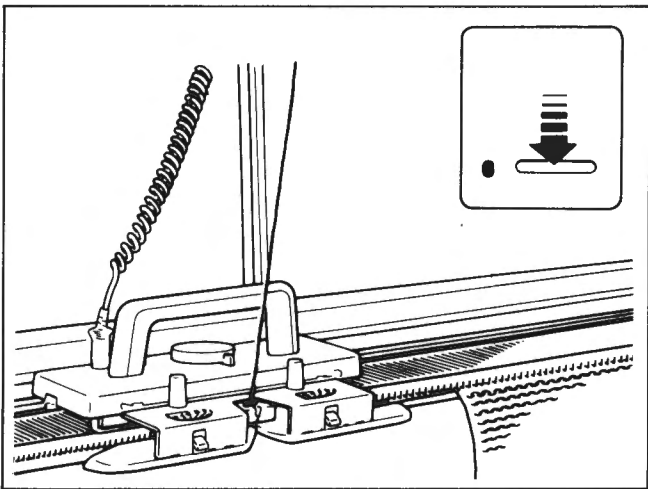

To knit Stockinet during pattern knitting

Press "ON" the Inspection Switch (light is on), and knit with the Cam Lever at "O" (STOCKINET).

If you fail to press "ON" the Inspection Switch, the Pattern Card continues to advance.

To knit in pattern knitting again, re-set the Cam Lever to the original position and press the Inspection Switch "OFF"

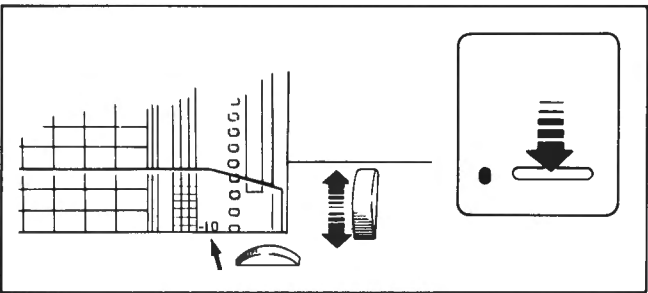

To knit a selected pattern row repeatedly

1. Press "ON" the Inspection Switch.
2. Set the selected pattern row of the Pattern Card at the Card Slot.
3. Press "OFF" the Inspection Switch, the Card goes in and the selected pattern row is read.
4. Press "ON" the Inspection Switch, the Card comes out and stops. (Inspection Switch light is on.)
5. Start knitting, the same row of pattern is repeated.

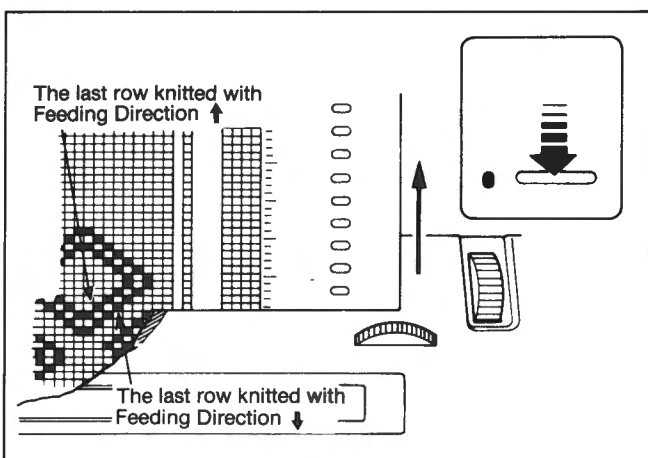

To check the knitted row with the pattern on the Pattern Card

1. Press "ON" the Inspection Switch, and the Card comes by 10 rows to show the row to be knitted up next, at the Card Slot.
2. Feed the Card an additional row to the direction opposite the Feeding Direction Pointer. This row of pattern corresponds to the last row knitted.

To start knitting again, return the Card by one row to its original position. Press "OFF" the Inspection Switch.

WHAT TO DO IF...

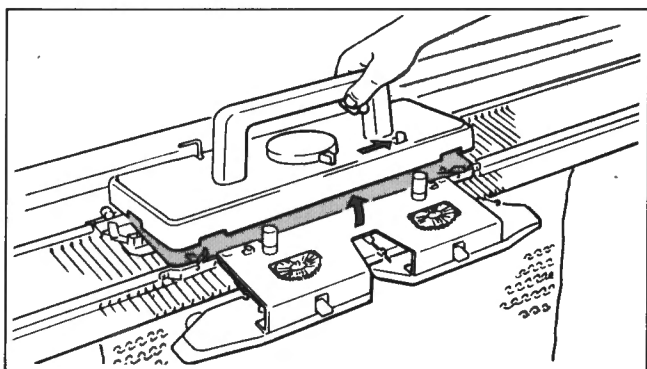

If the Carriage has jammed...

1. Remove the yarn from the Yarn Feeder.
2. Push the Release Lever in the arrow direction, and the top of the Carriage lifts up.

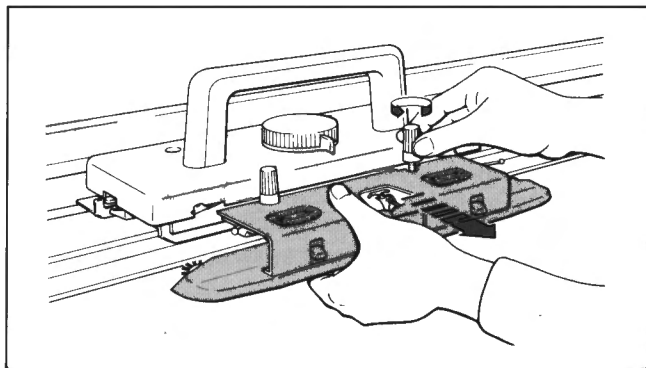

If the yarn has entangled with the Brushes on the Arm or Yarn Feeder, remove the Arm from the Carriage and disentangle the yarn.

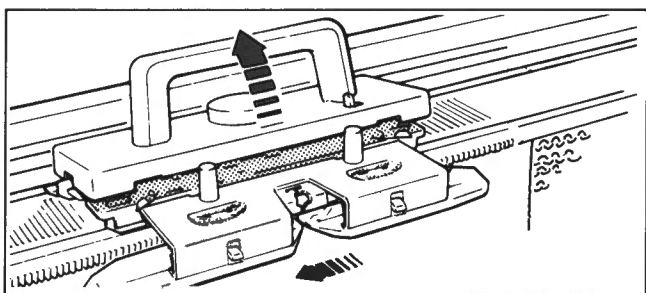

3. With the top of the Carriage up, move the Carriage in the direction it was going till it gets clear of the knitting.

If the Point Cams are in use, move the Carriage until it passes the Cam.

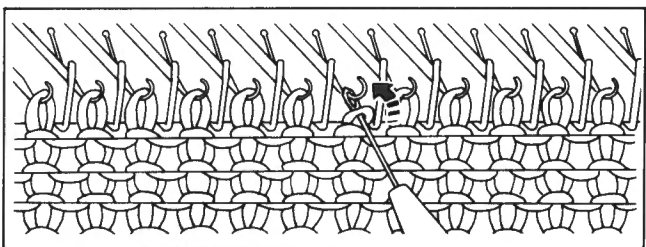

4. Check the stitches, and if stitches have moved behind the latches, replace them into the hooks using a Transfer Tool.
5. Align the working needles in B position and unravel the incomplete row referring to page 46.

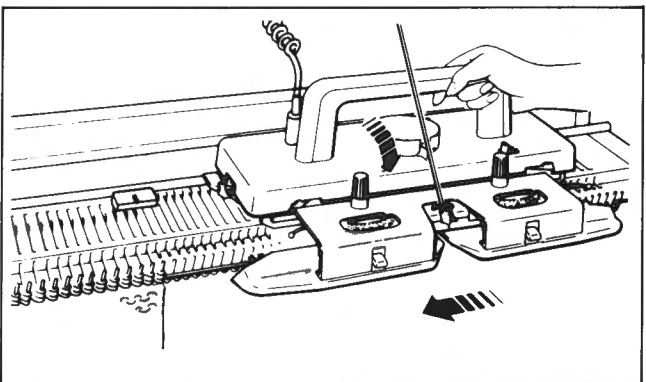

6. With the top of the Carriage up, pass the Carriage to the side with the yarn end. Press down the top of the Carriage and continue to knit.

If the Row Counter, the Knit Contour (Radar) and/or the Pattern Card is/are in use, refer to "If incorrectly knitted..." on page 51 ~ 52 before continuing to knit.

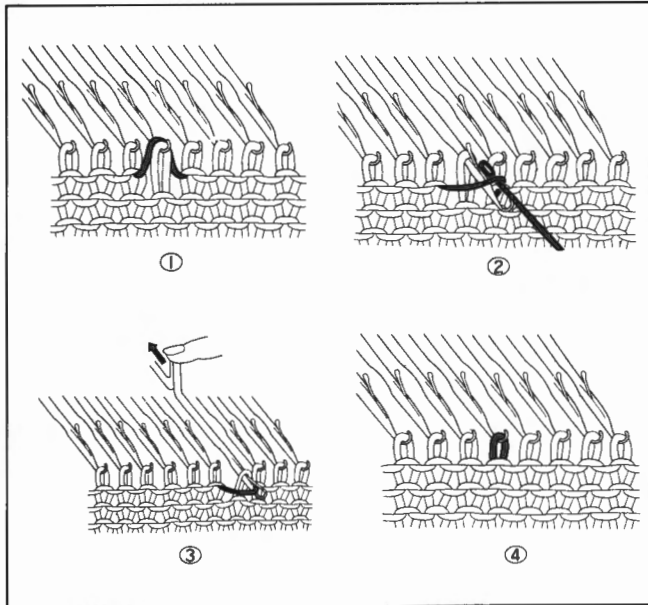

If a stitch has dropped during knitting...

1. Insert a One-Eye Transfer Tool into a stitch below the dropped stitch and replace it into needle hook together with loose yarn.
2. Slowly pull the needle out until the stitch is behind the open latch leaving the loose yarn in the hook.
3. Push the needle back so the latch will close and the stitch behind will slide over the hook reforming a stitch as illustrated.

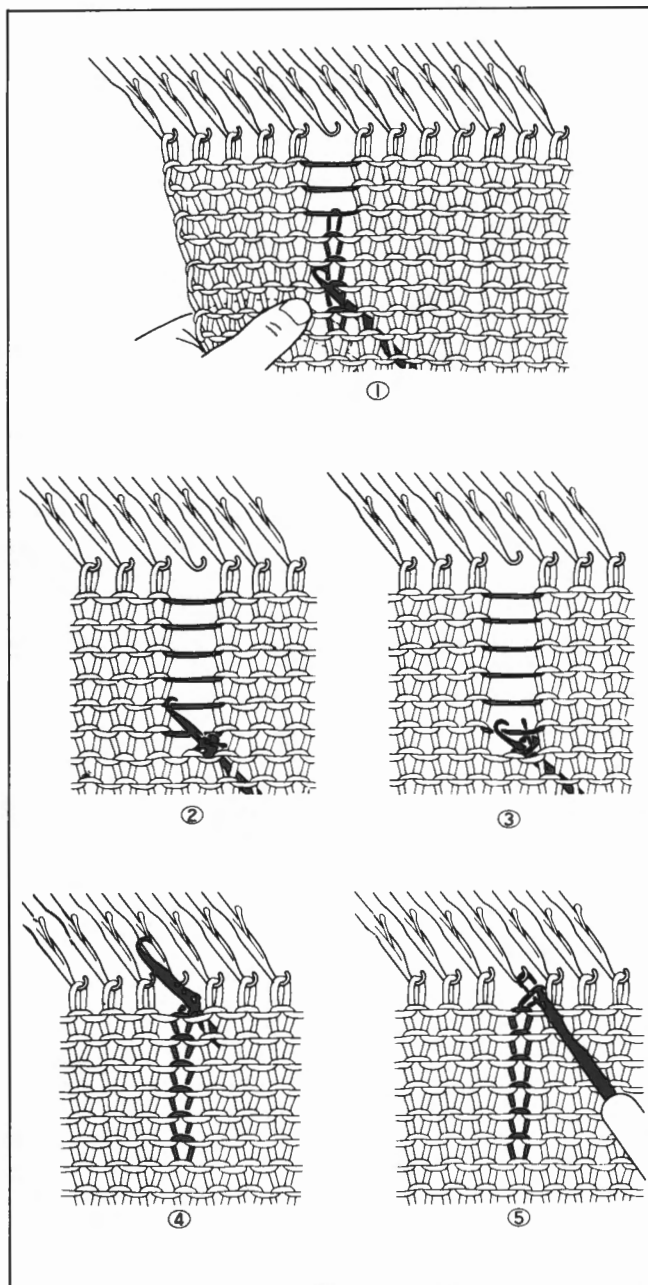

IN CASE A STITCH HAS DROPPED AND RUN DOWN FOR SEVERAL ROWS:

1. Insert a Tappet Tool into the stitch a few rows below the dropped stitch, from the side away from you. Unravel the stitches down to the Tappet Tool.

Hint: With the other hand, pull the knitting downwards. This makes unravelling easier.

2. Push the Tappet Tool towards you so the stitch moves behind the open latch. Catch the yarn crossing above into the hook.
3. By pulling the Tappet Tool backwards, the latch will close and the loose yarn will be trapped in the hook.
4. Continue pulling and the old stitch will slide over the closed latch forming a new stitch in the hook.
5. Repeat this operation up to the top.
6. Place the top stitch onto the needle hook.

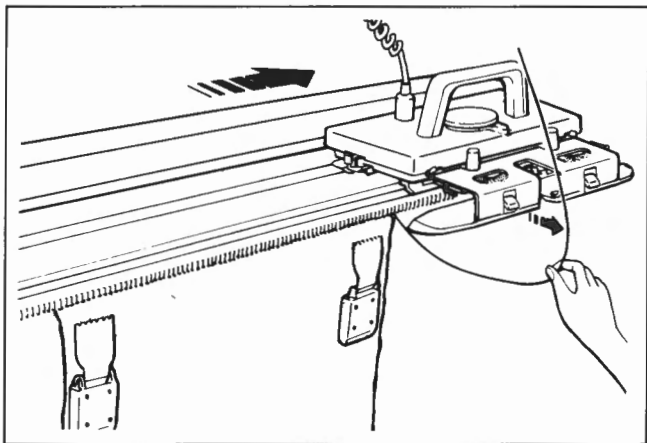

If incorrectly knitted...

(In case of knitting in Stockinet, follow the procedures 1, 2, 4, 5, 8 below.)

1. Have the Carriage clear of the working needles and remove the yarn from the Yarn Feeder.

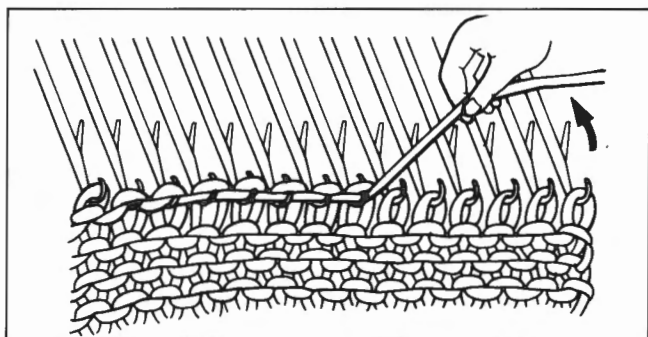

2. Refer to page 46 and unravel the incorrectly knitted rows.

IN CASE OF USING THE PATTERN SWITCH-3:

If an odd number of rows are unravelled, unravel an extra row to make the total unravelled rows an even number.

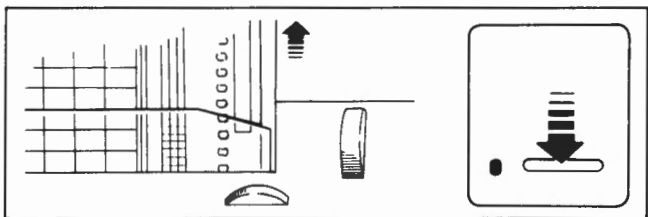

3. Press "ON" the Inspection Switch. (Light is on.)

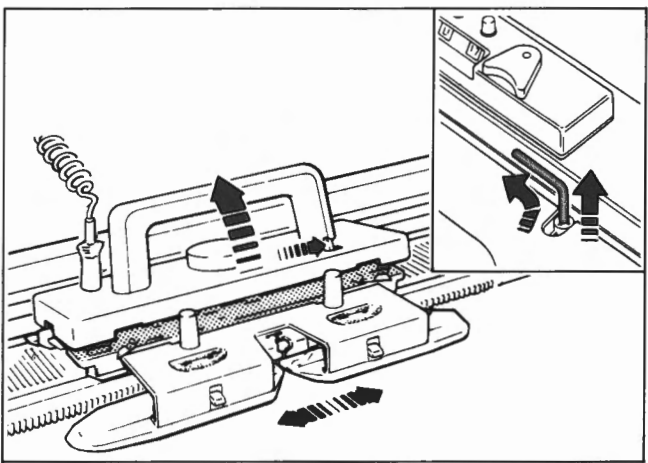

4. If the Carriage is on the side opposite the yarn, turn the right Feeding Tripper to the side to disengage it from the Row Counter. (Refer to page 9.) And move the Carriage to the same side as the yarn using the Release Lever. (Refer to page 9.)

Replace the yarn into the Yarn Feeder.

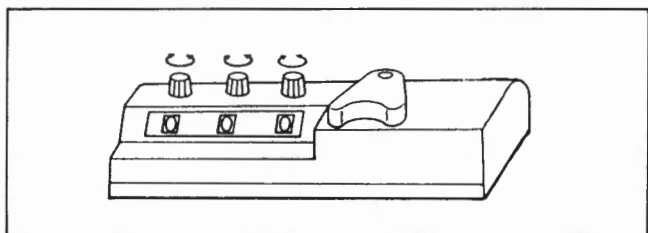

5. Return the Row Counter by the same number as you have unravelled. (If the Knit Contour (Radar) is in use, return the Pattern Paper, too.)

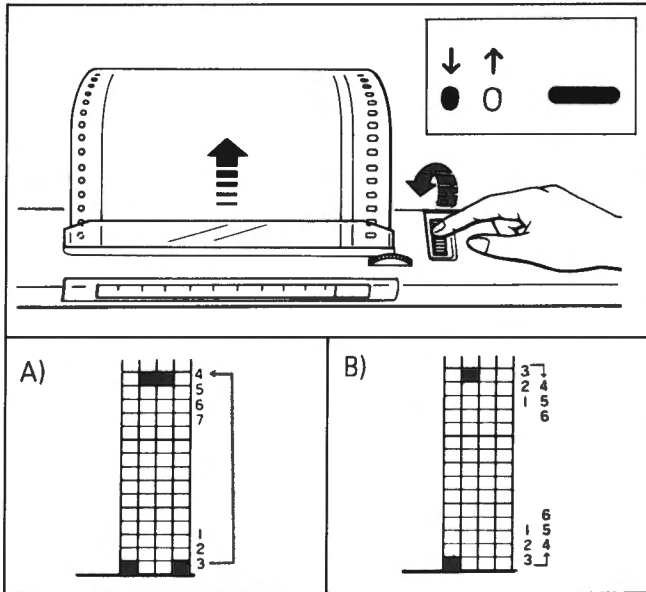

6. Return the Pattern Card by the same number of rows as unravelled in the direction opposite to that shown by the Feeding Direction Pointer. (In case of using the Pattern Switch-3, return the Pattern Card by only half the number of rows unravelled.)

- A) When returning the Pattern Card, if you reach the first row of the pattern before returning the total rows required, turn the Card to the top row, and count the remaining rows from the top of the Card.
- B) If the pattern is knitted in reverse from the top to the first row, count the rows in the direction reverse to that the Card advances.

Don't count the top or bottom end row twice.

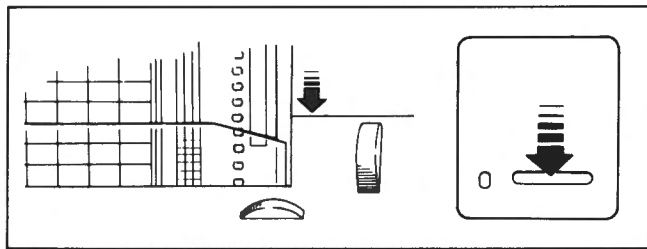

7. Press "OFF" the Inspection Switch. (The Pattern Card is fed downwards by 10 rows and the row to be knitted is read.)

8. Reset the Feeding Tripper to the original setting and press down the top of the Carriage. Continue to knit.

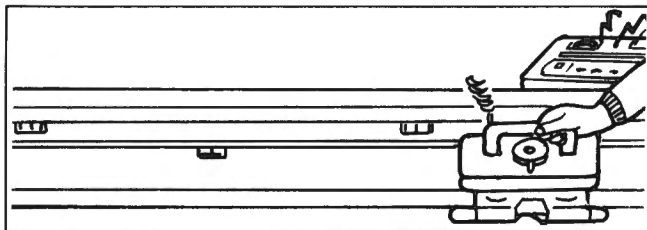

If the warning buzzer sounds during knitting or if you notice that you are knitting incorrectly...

If you move the Carriage when the Pattern Card is in quick motion, or if you are moving the Carriage too fast, the warning buzzer will sound.

When the buzzer sounds or you notice a mistake, follow the instructions below.

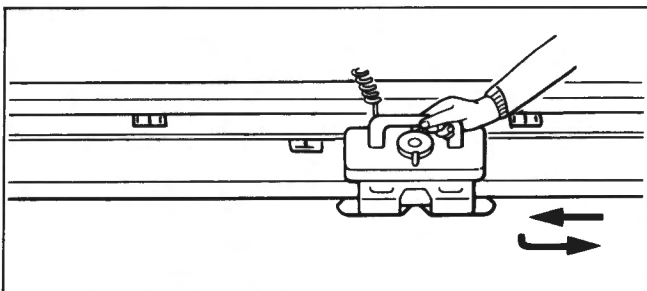

IN CASE YOU STOP THE CARRIAGE BEFORE THE CARRIAGE ENCOUNTERS OR CLEARS THE SECOND (THE LAST) POINT CAM:

1. Return the Carriage to the beginning of the row using the Release Lever. (Refer to page 19.)
2. Repair the stitches and unravel the incomplete row.
3. Press down the top of the Carriage and continue to knit.

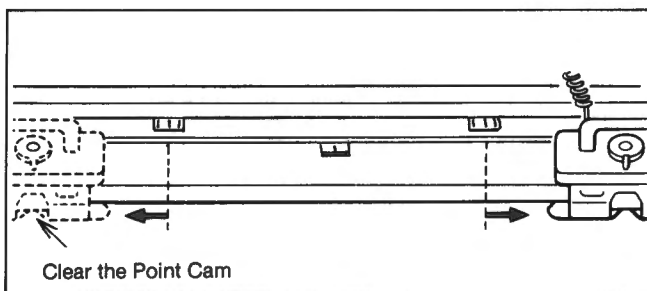

IN CASE YOU STOP THE CARRIAGE WHEN THE CARRIAGE HAS ENCOUNTERED OR CLEARED THE SECOND (THE LAST) POINT CAM:

1. Using the Release Lever, move the Carriage in the direction it was going till it clears the working needles.
2. Press "ON" the Inspection Switch.
3. Return the Carriage to the opposite side using the Release Lever.

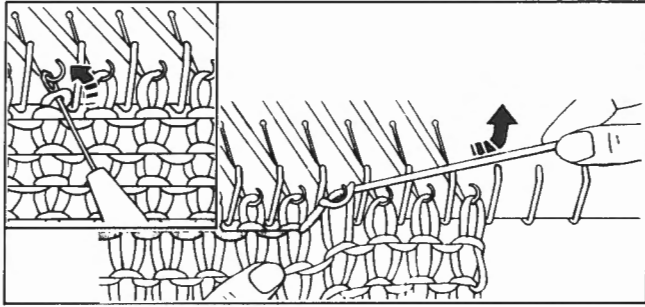

4. Repair the stitches and unravel the incomplete row.
5. Turn back the Pattern Card 1 row.
6. Press "OFF" the Inspection Switch.
7. Press down the top of the Carriage and continue to knit.

The procedures above is the same as "If incorrectly knitted..." on page 51 ~ 52. So refer to that procedures.

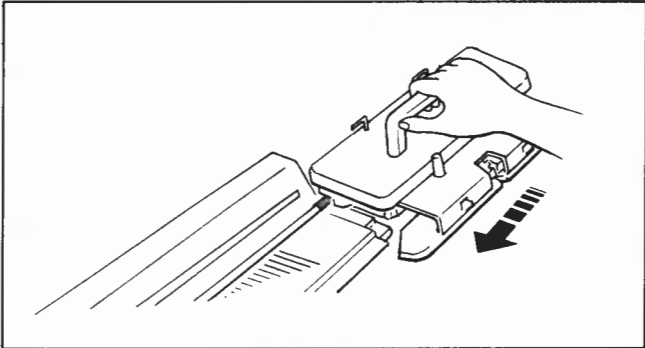

If the Carriage has been removed from the Needle Bed...

Replace the Carriage on the Needle Bed by sliding the Carriage Pipe onto the rail.

Ensure that the Carriage moves smoothly across the Needle Bed.

If the Pattern Card is in use, press "ON" the Inspection Switch and memorize the positions of the Point Cams and Needle-1 Cam with the Carriage. Refer to page 47.

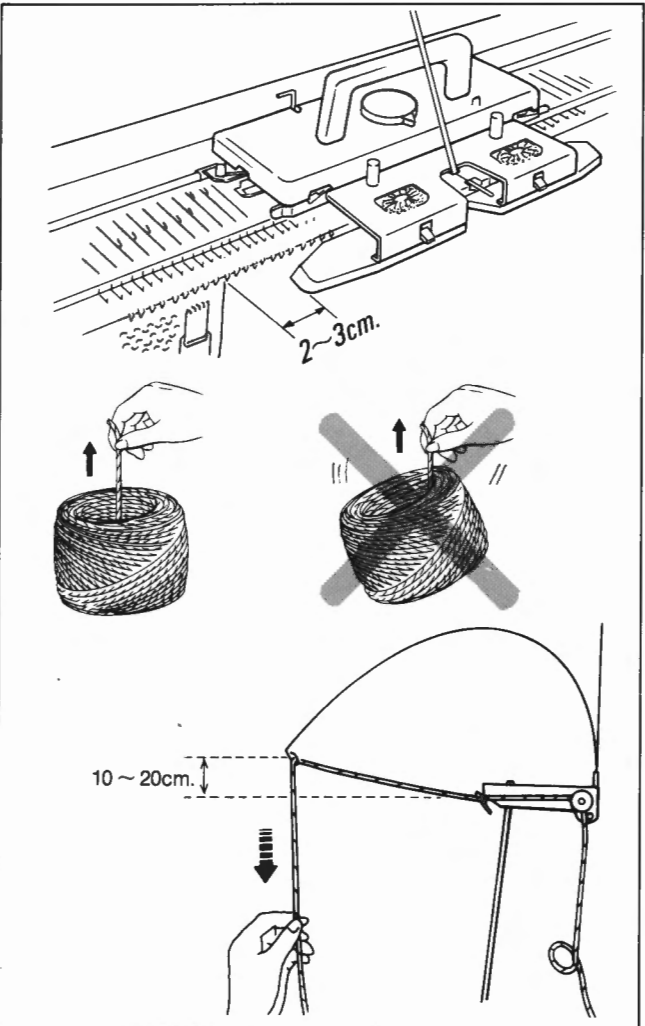

If the end stitches are not stable or if the Carriage is heavy to operate...

Check the following points.

1. Has the Arm passed the last knitting needle by 2 ~ 3cm. before knitting the next row? (Refer to page 14.)
2. Is the yarn coming out freely from the inside of yarn ball? (Refer to page 10.)
3. Is the yarn threaded into the Auto-Tension correctly? (Refer to page 11.)
4. Is the machine lubricated properly? (Refer to page 55.)

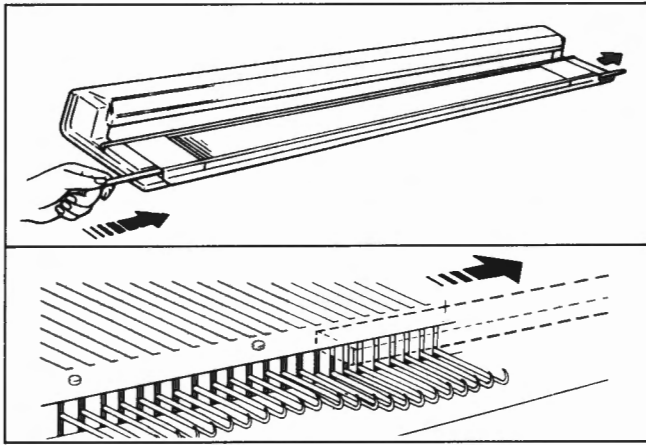

If a needle has been damaged...

Using a pencil or a screw driver, push the Needle Retainer in either direction.

Pull the Needle Retainer towards one end until it clears the needle to be replaced.

If a stitch is hooked on the needle, use the Tappet Tool to pick up the stitch.

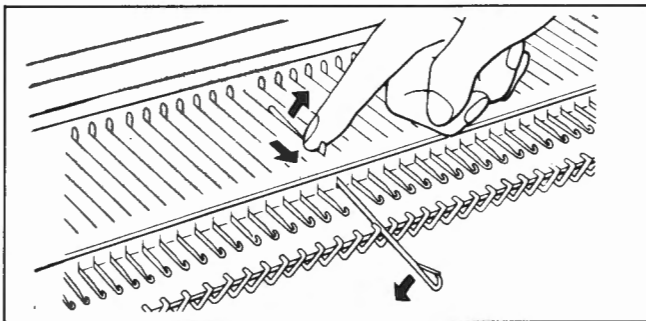

Push the damaged needle to D position. Close the latch and press the needle down. The shank will come out of the Needle Bed.

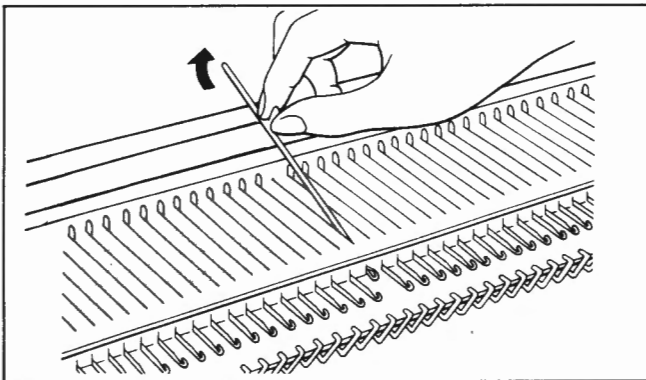

Lift up the needle by holding the butt and pull it to remove from the Needle Bed.

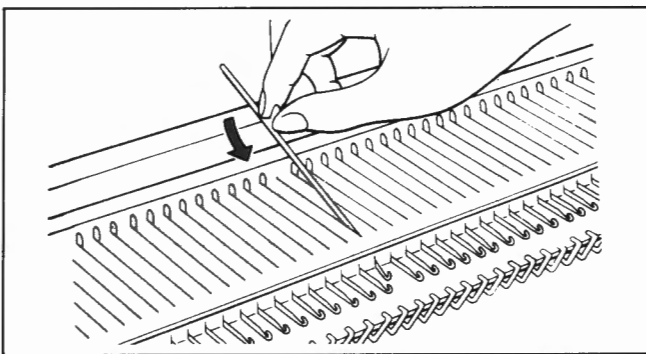

To replace a new needle, open its latch and slide it into the Needle Bed groove until the hook comes out of the front opening of the Needle Bed.

Push the needle back to A position by holding the butt.

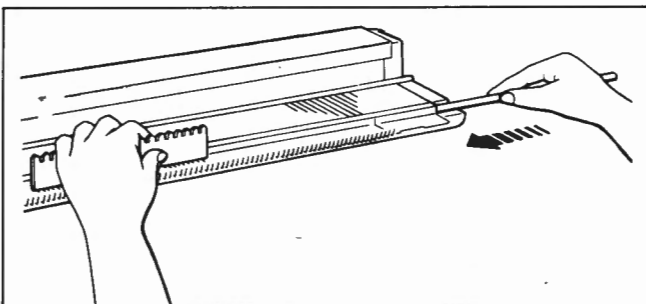

Insert the Needle Retainer back into the Needle Bed by pushing the protruding end. To insert the Needle Retainer, press the floated needles at the front edge of the Needle Bed using the Needle Pusher.

If a stitch is held on a Tappet Tool, replace it on the new needle.

MAINTAINING THE MACHINE

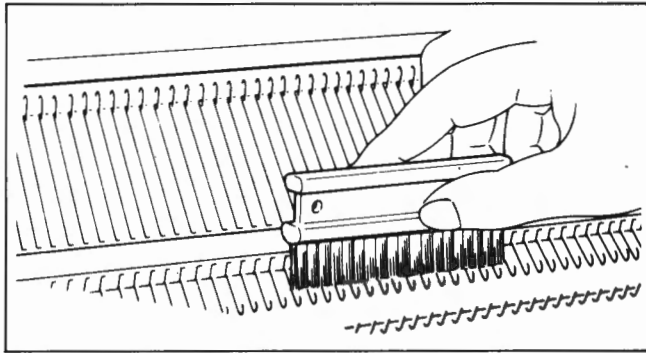

Needle Bed

Remove all lints from Needle Bed with Cleaning Brush.

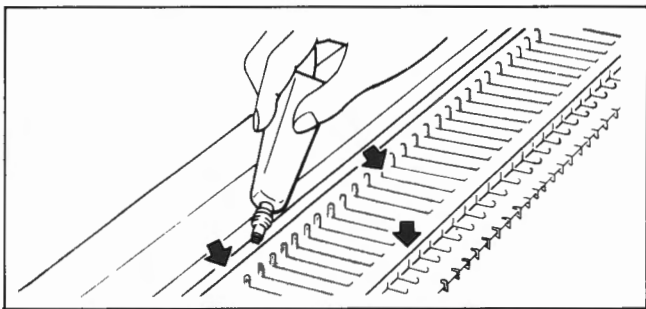

Apply oil along the rail and front guide of the Needle Bed.

Wipe needle butts with a piece of oil cloth.

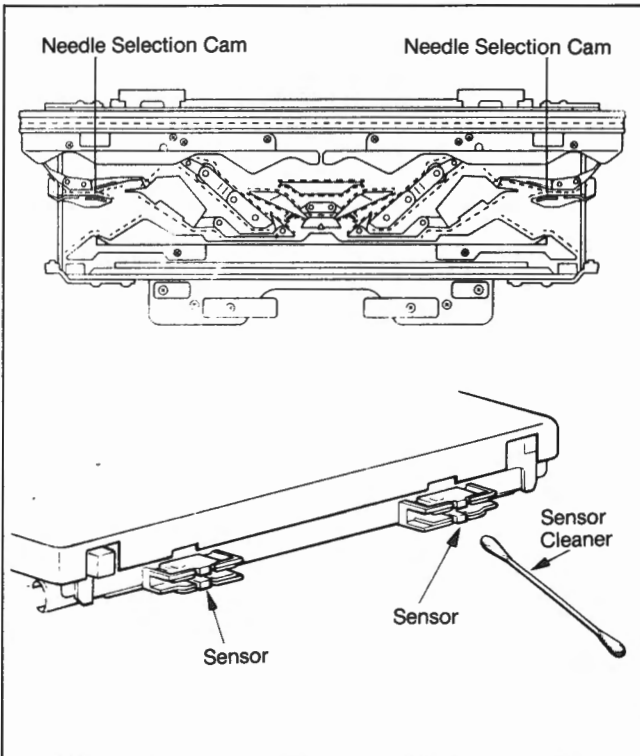

Carriage

Turn over the Carriage and brush off all fluff.

Wipe the places indicated by the dotted line in the diagram with the oil cloth.

Oil the Needle Selection Cams.
(Lack of oil on these parts will cause incorrect needle selection.)

Clean the Sensors with the Sensor Cleaner.
(The Sensors scan and control the needle selection for the stitch pattern.)

Don't wipe the Sensors with the oil cloth.

REPACKING THE MACHINE

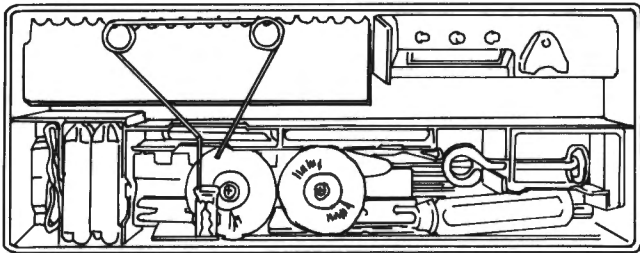

Replace the Accessories in the Accessory Box.

Remove the Pattern Card from the Pattern Card Panel.
Do not fold or bend it.

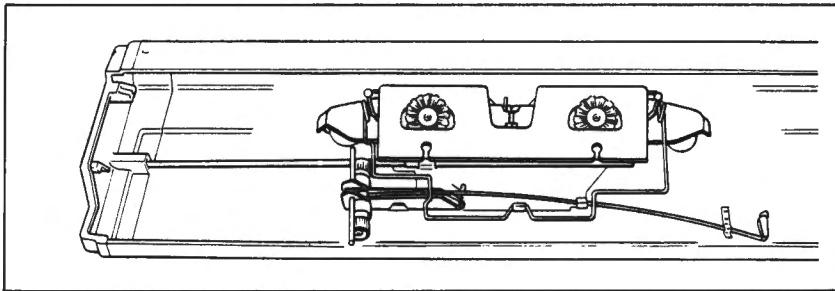

Remove the Auto-Tension and the Arm from the Carriage and pack them inside the Top Cover.

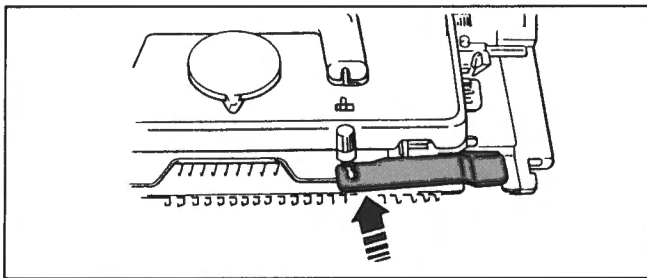

Secure the Carriage to the Needle Bed with the Carriage Fastener.

Lay the Carriage Handle down.

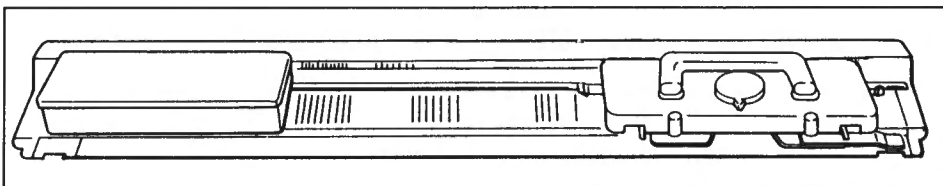

Replace the Accessory Box on the left end of the Needle Bed.

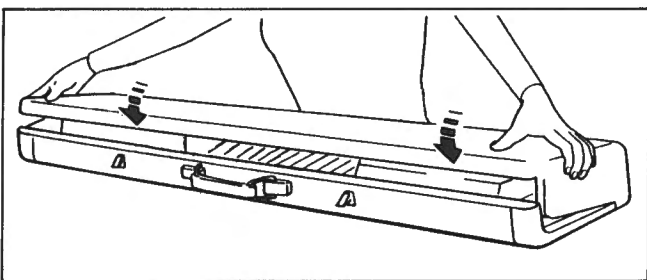

Place the Top cover onto the Needle Bed.

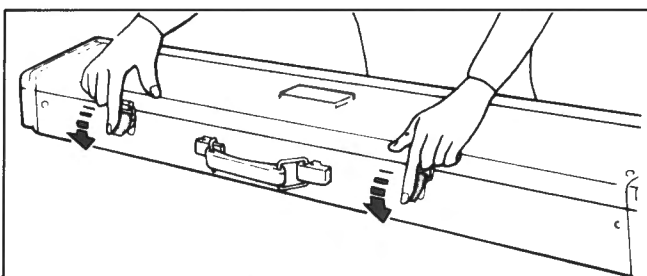

Fasten the latches.

TO STORE THE MACHINE

Keep the machine away from.

1. Too much moisture.
2. Abnormal change of temperature.
3. Salt or chemicals.

DRAWING A PATTERN ON THE DESIGN CARD

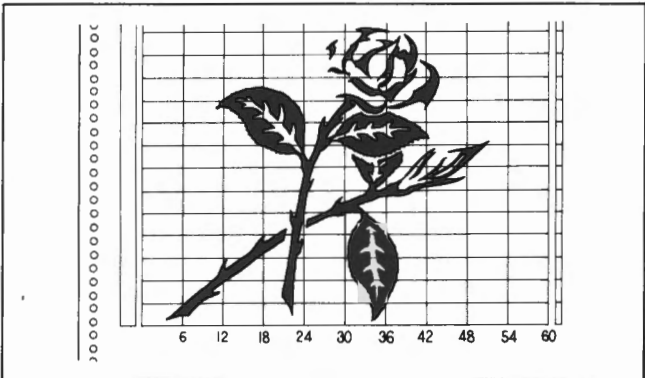
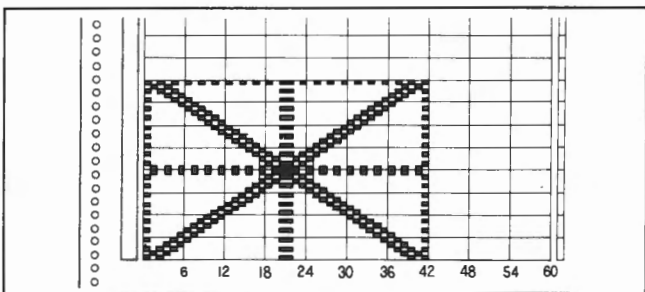
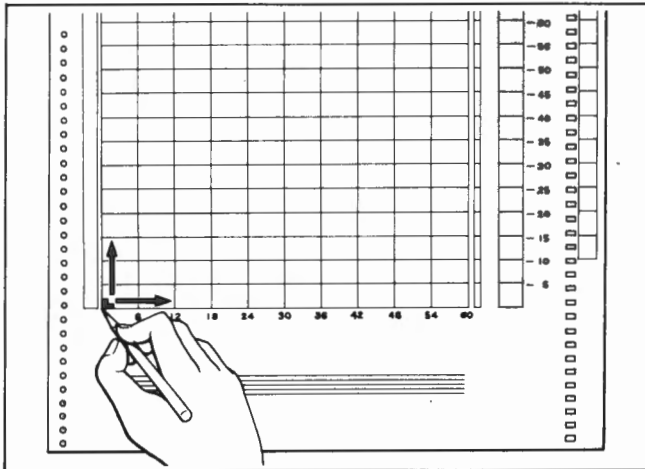

Draw your own pattern or trace a pattern from the pattern book onto the Design Card supplied with the Pattern Card set using a Design Pencil.

Fill up the sections neatly for the pattern taking the following precautions.

Start filling the sections from the bottom left corner.

Work on a solid hard surface.

Darkness of each section must be even.

To avoid failure in drawing, make a rough sketch and trace it onto the Design Card.

Incorrect drawing can be erased using a plastic eraser.

* In a picture or a letter image, draw the entire area rather than section by section. (Three-star Pencil is recommended.)

* For geometric pattern, fill up sections one by one with care. (One-star pencil is recommended.)

Take care when drawing a pattern design for the following type of knitting.

In Single Motif:

As the Pattern Switch-1 is used with its left light on, draw the area to be knitted in Single Motif.

In Tuck or Slip stitch pattern:

As the Pattern Switch-1 is used with its right light on, draw the area to be tucked or slipped.

* Don't soil the blank column on the left side of the Card.

Buzzer Column and Instruction Columns.

Put marks to correspond with the first and end row of the pattern as shown below.

Notation Columns

Mark with an ordinary pencil at the rows to change the yarns or to change the settings for knitting.

In case of knitting in the same direction continuously

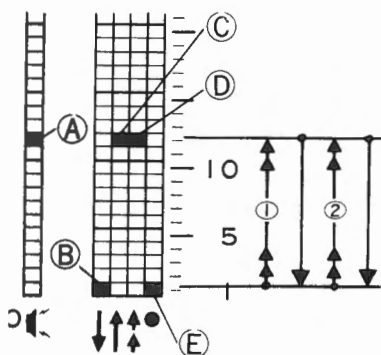

In case of knitting in both directions row by row

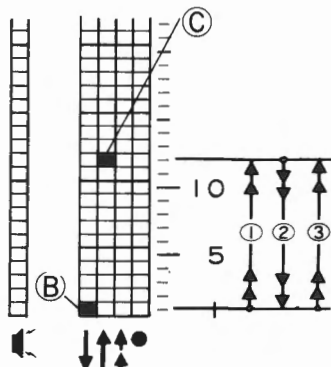

Markings on each column

- (A) Mark for colour change, or to alter machine settings.
- (B) Moves the Card downwards.
- (C) Changes the feeding direction. (The Card is fed upwards.)
- (D) Actuates quick motion.
- (E) Stops quick motion.

TO KNIT GARMENTS

CONTENTS

	page
TAKING A TENSION GAUGE	59
Tension gauge	59
To knit a tension swatch	59
Gauge Scale	61
How to measure the tension swatch	61
KNITTING TECHNIQUES	62
Decreasing 1 stitch	62
Fully fashioned decrease	62
Increasing 1 stitch	63
Fully fashioned increase	63
Decreasing multiple stitches	64
Increasing multiple stitches	64
Partial knitting	65
-Decreasing stitches	65
-Increasing stitches	66
K1.P1. Rib	68
Mock Rib	70
Picot Hem	71
Holding stitches	72
-In D position	72
-Using Ravel Cord	72
-Waste Yarn	73
To make yarn mark	74
To cast off with Transfer Tool	74
To cast off with Tappet Tool	75
To make a buttonhole by transferring stitches	76
Seaming on the machine	77
-Stitch to stitch	77
-Open stitches to side edge	79
Joining by hand	80
-Blind Stitch	80
-Grafting	80
-Slip Stitch	81
Sewing in yarn ends	81
Cord Knitting	82
Cable Pattern	82
Garter Stitch	83
Blocking and pressing	83
OPTIONAL ATTACHMENTS	84
Design Controller, PE1	84
Knit Contour (Radar), KR7 and KR10	84

TAKING A TENSION GAUGE



Tension gauge

Tension Gauge indicates how many stitches you need to cast-on, and how many rows you need to knit to make a 10cm. square. It is very important to take a correct tension gauge to knit a garment in your desired size.

To take a correct tension gauge, the tension swatch must be knitted in the same stitch pattern, with the same yarn and Stitch Dial as to be used for the garment.

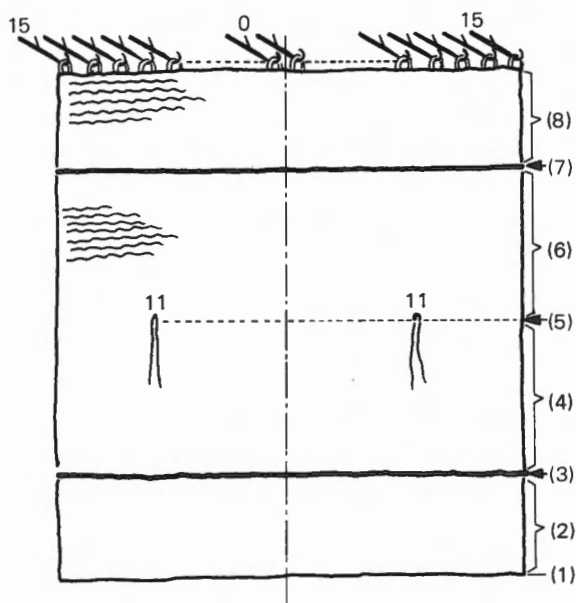

To knit a tension swatch

Prepare the yarn you selected and a small amount of contrasting colour yarn for marking the swatch.

Decide on the Stitch Dial number referring to page 12. It is recommended that you try different Stitch Dial settings till you obtain a suitable tension for the yarn and stitch pattern chosen.

Knit the swatch as instructed below.

The method below is for knitting a tension swatch in Stockinet, but if you knit the swatch in a pattern stitch using a Pattern Card, follow the additional instructions given after  mark as well.

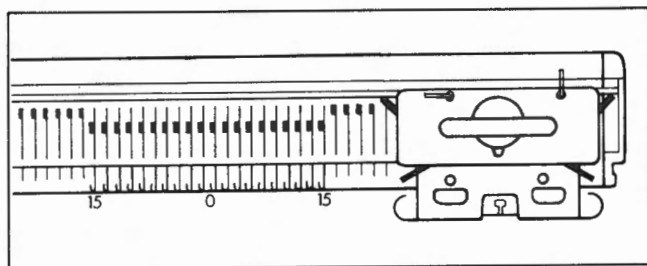

- (1)  **Press "ON" the Inspection Switch and set the selected Pattern Card. Set the Pattern Width Indicator.**

Push 15 needles on both sides of the centre(0) to B position. 30 needles altogether.

-  **Set the Needle-1 Cam and the Point Cams.**

Cast on with main yarn.

-  **Press "OFF" the Inspection Switch.**

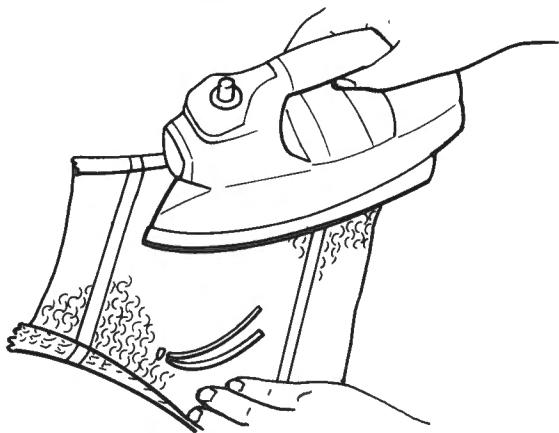
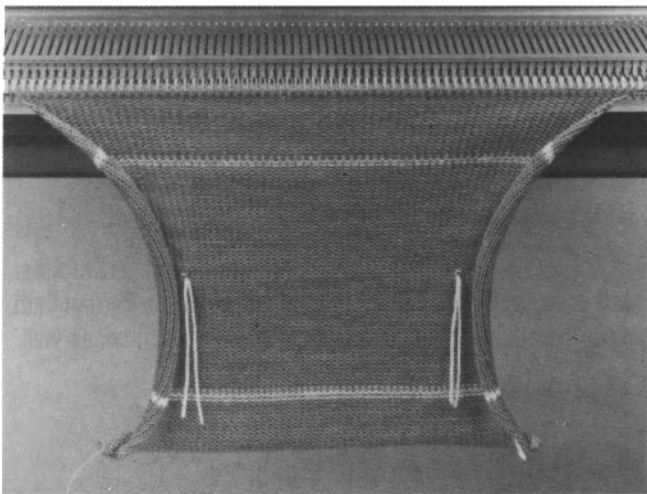
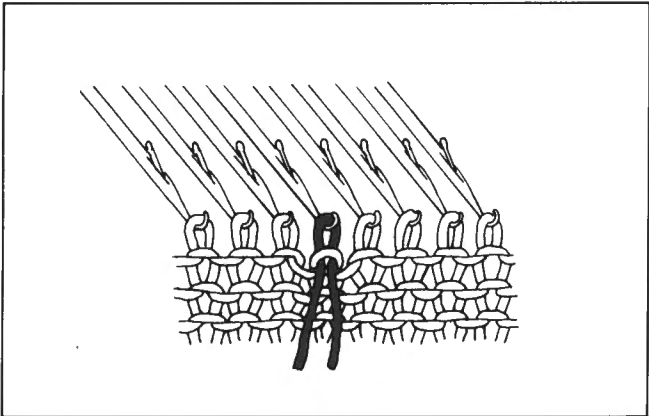
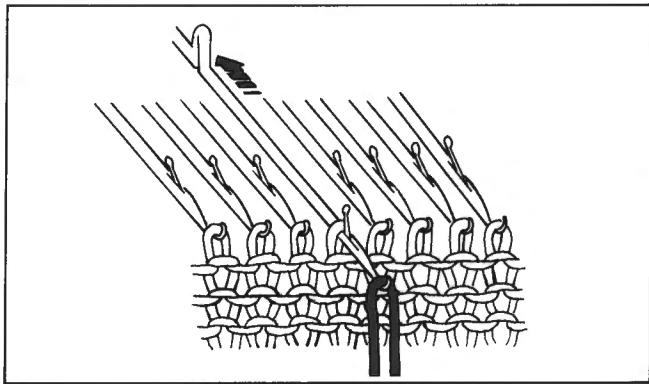

(2) Knit 10 rows in selected stitch pattern, with Stitch Dial on setting chosen.

Press "ON" the Inspection Switch.

(3) Change to the contrast yarn, and knit two rows in Stockinet.

Press "OFF" the Inspection Switch.

(4) Remove contrast yarn and rethread the main yarn. Knit 15 rows in selected stitch pattern with correct Stitch Dial setting.

(5) Push the 11th needles on either side of centre(0) to D position and place a piece of contrast yarn in each of the needle hooks. Push the needles back to B position by hand.

(6) Knit another 15 rows.

Press "ON" the Inspection Switch.

(7) Thread the contrast yarn and knit 2 rows in Stockinet.

Press "OFF" the Inspection Switch.

(8) With main yarn, knit 10 rows in selected stitch pattern with correct Stitch Dial setting.

Remove the yarn from the Yarn Feeder.

Set the Cam Lever to Stockinet.

Remove the swatch from the machine.

MAKE A NOTE OF THE STITCH DIAL NUMBER.

Allow the swatch to rest for several hours, to return to its natural condition, after being stretched on the machine. Press lightly with a steam iron, or with an ordinary iron over a damp cloth. Allow to dry before taking tension gauge.

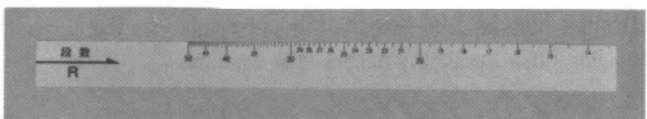
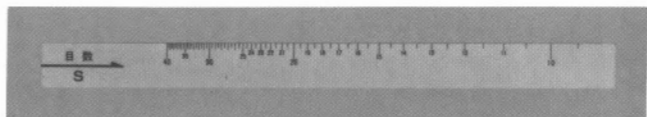

Gauge Scale

This scale is designed to get how many stitches and rows per 10cm., measuring between yarn marks on the tension swatch.

The scale has two sides. The side "S" is used for measuring stitches and the side "R" is for rows.

Following the instructions below, measure and get correct tension gauge.

How to measure the tension swatch

Stitch (Horizontal)

Place the Gauge Scale (blue) with the "S" side up, onto the tension swatch so as the left end of the Scale is touching the inside of the stitch in a contrast yarn. Measure to the point of the other contrast stitch and read the number which corresponds with this stitch. The Scale should be read from the side indicated by the arrow, i.e. from the left side.

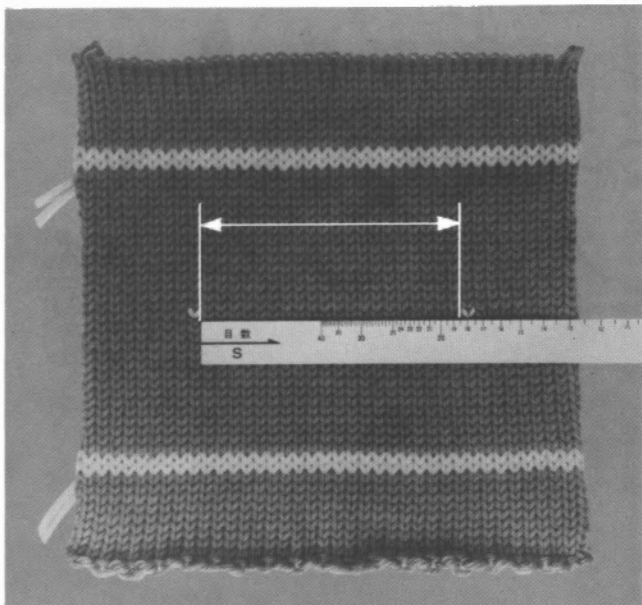

Row (Vertical)

Place the Gauge Scale (blue) with the "R" side up, onto the tension swatch so as it covers the length in between the rows knitted in a contrast yarn. Measure this length and the number indicated on the Scale should be read from the side indicated by the arrow.

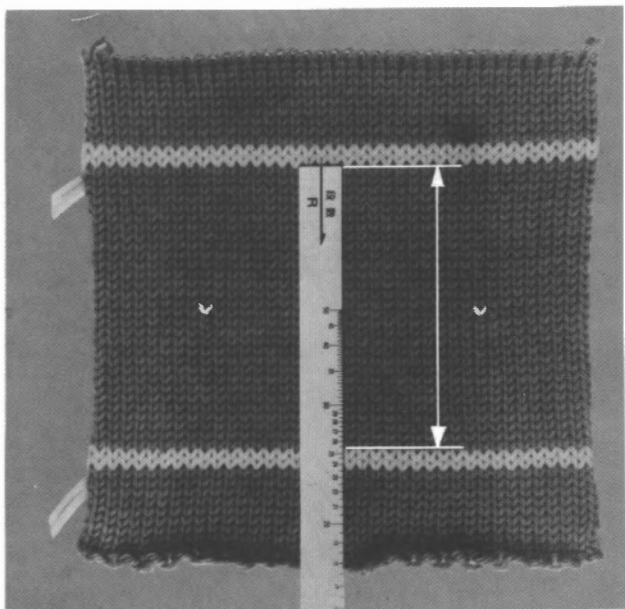

KNITTING TECHNIQUES

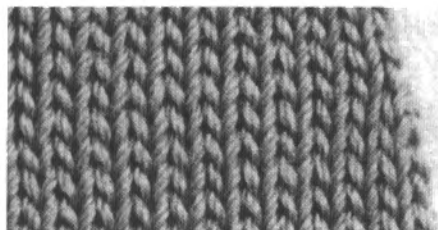

Decreasing 1 stitch

You can decrease 1 stitch on both sides of the same row. Using a Transfer Tool, transfer the end stitch onto the adjacent needle. Push the empty needle to A position.

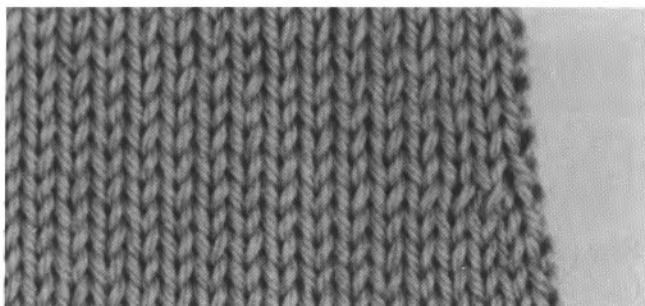
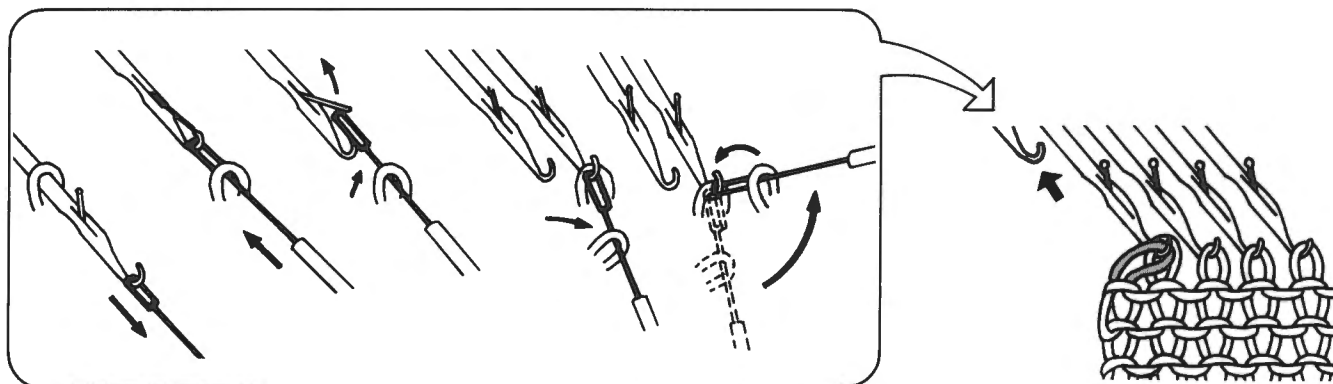

Fully fashioned decrease

You can decrease 1 stitch on both sides of the same row. The needle with two stitches on it is the second one in from the edge.

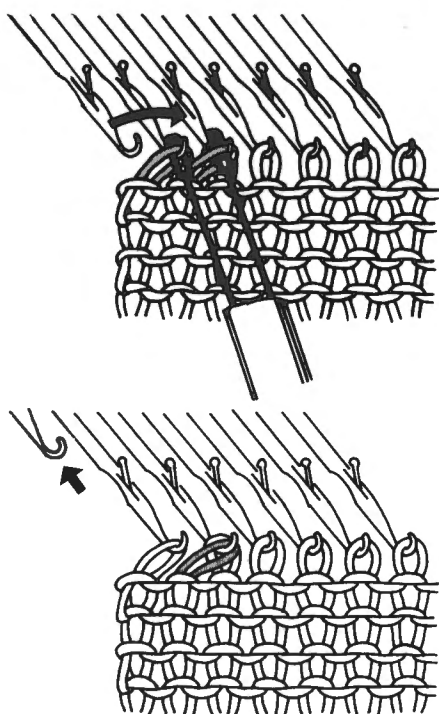

1. Using a two prong Transfer Tool, transfer the two end stitches one needle in.

2. Push the empty needle back to A position. Continue to knit.

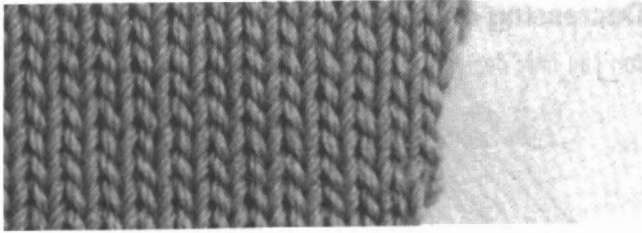

Increasing 1 stitch

You can increase 1 stitch at a time only on the Carriage side of the knitting.

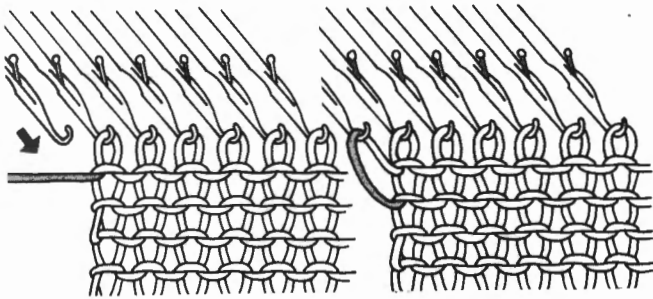

Push 1 needle on the Carriage side from A to B position and knit 1 row.

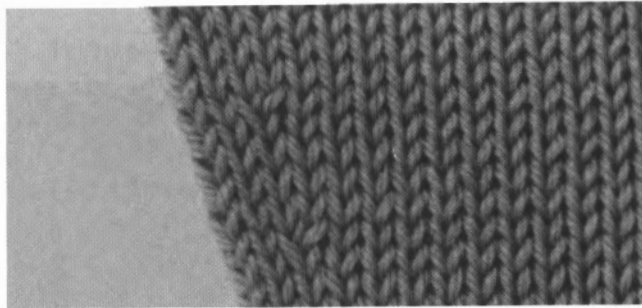

Fully fashioned increase

You can increase 1 stitch on both sides of the same row.

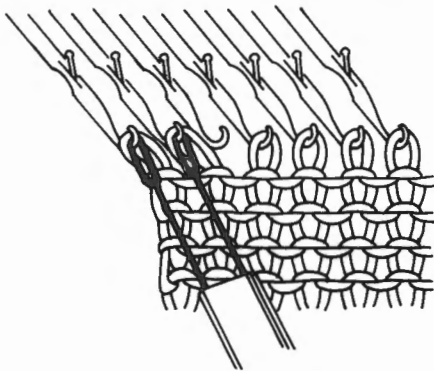

1. Push the adjacent empty needle to B position.
Using a two prong Transfer Tool, transfer the two end stitches one needle out.

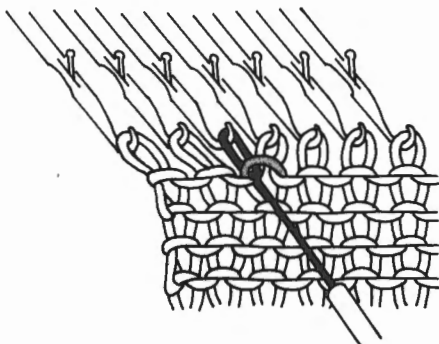

2. Pick up the loop below the third stitch and place it onto the empty needle as shown.
Continue to knit.

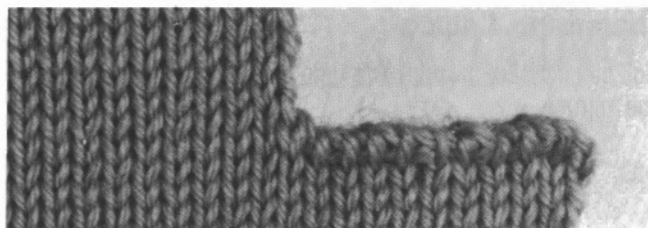

Decreasing multiple stitches

You can only decrease on the Carriage side.

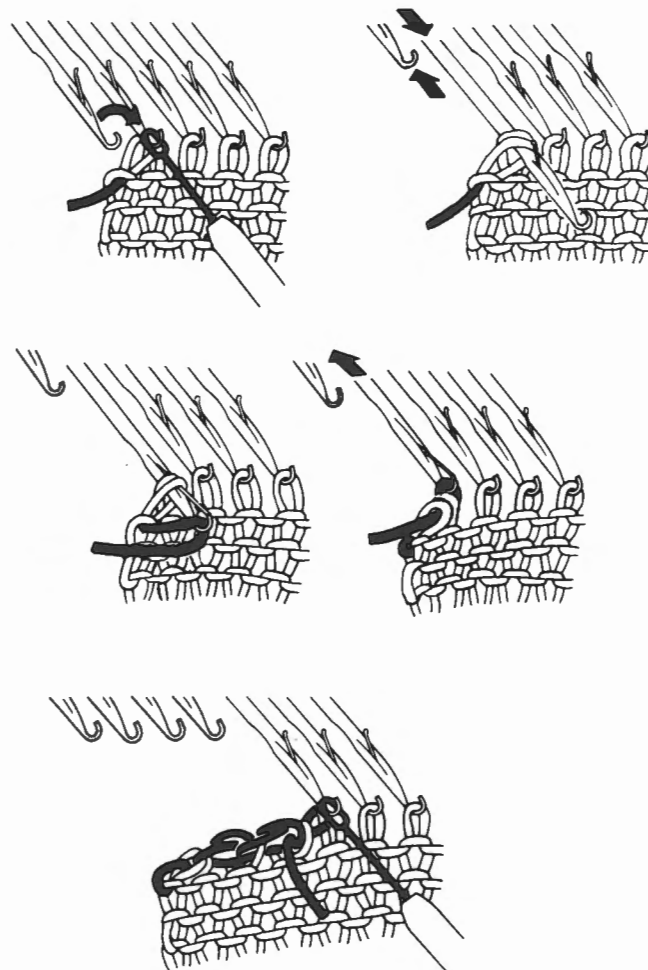

To decrease at the left edge:—

1. With the Carriage on the left, hold the knitting back towards the machine.
Transfer the end stitch to adjacent needle. Push the empty needle back to A position.
2. Push the second needle to D position until both stitches are behind the latch.
3. Lay yarn from left to right in the open hook of the needle.
(When decreasing at the right edge, lay yarn from right to left.)
4. Hold yarn slightly down and push the needle back to B position.
The two stitches slip off the needle leaving a new stitch.
5. Continue the same procedure until the required number of stitches have been decreased.
Place the last decreased stitch onto its adjacent needle.

* Repeat in reverse to decrease on the right.

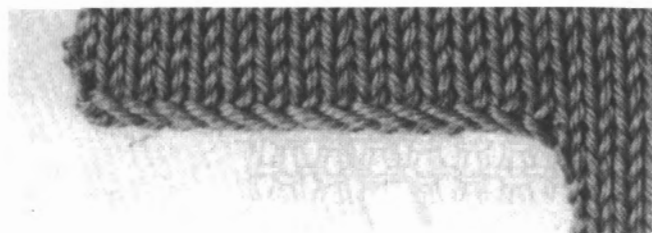

Increasing multiple stitches

You can increase only on the Carriage side.

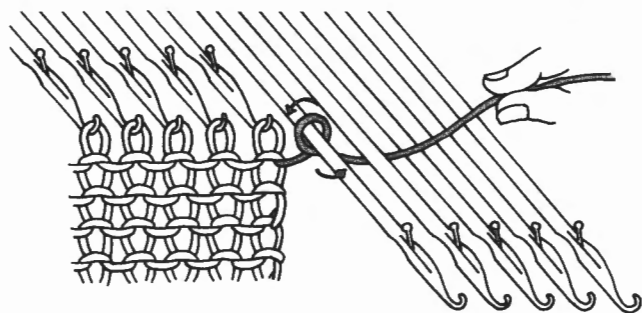

When the Carriage is on the right side:—

1. Push the required number of needles from A to D position. Pull some yarn from the Yarn Feeder and wind it loosely around the empty needles in the anti-clockwise direction.
2. Push loops against sinker posts, eliminate slack yarn, and continue knitting with the Russel Levers at "III".

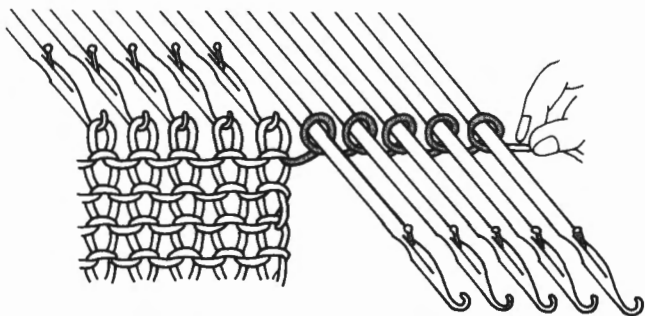

When the Carriage is on the left side, wind yarn around needles in the clockwise direction.

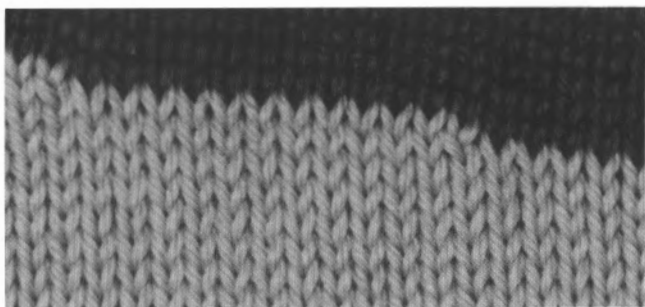
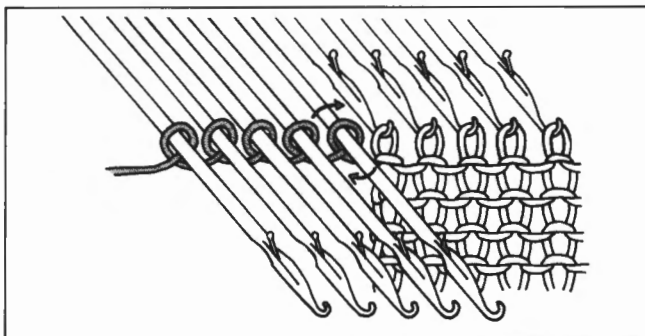

Partial knitting

PARTIAL KNITTING is used to shape a gentle slope, such as shoulders, darts, etc. -

You can do partial knitting only on the opposite side to the Carriage. If you wish to shape both sides, work left and right alternately.

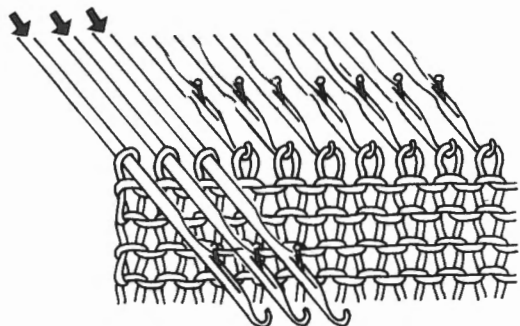

Decreasing stitches

Set the Russel Levers to "I".

1. Push the needles to be decreased to D position on the opposite side to the Carriage.

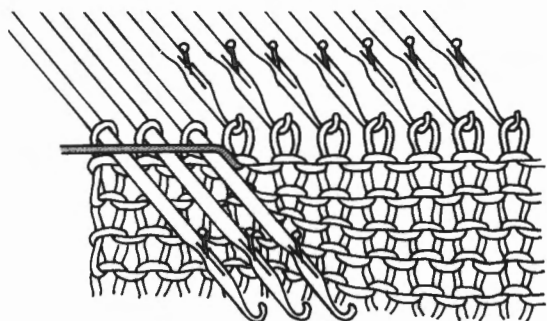

2. Knit 1 row.
(The needles in B position knit. The needles in D position remain inactive and the yarn passes over them.)

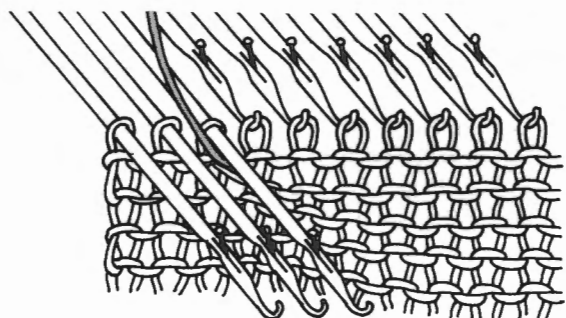

3. To prevent a hole from being formed in the knitting, pass the yarn under the first inside needle in D position and over the remaining needles. (If partial knitting is required on both sides, repeat step 1 before knitting the next row.)

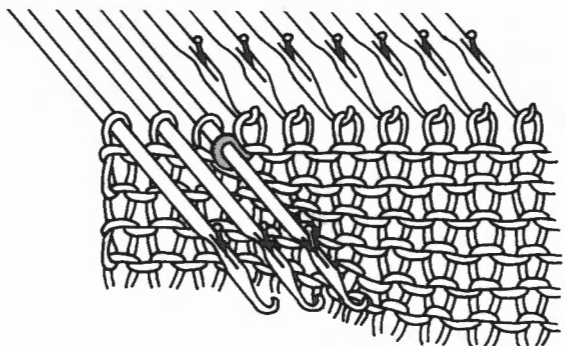

4. Knit 1 row.
This completes the first operation of partial knitting. (If partial knitting is required on both sides, apply step 3.)

Repeat steps 1 ~ 4.

After completing partial knitting, continue as follows.

A. Stockinet

Push the needles in D position on the opposite side to the Carriage back to C position. Knit 1 row. Needles in C position will knit and return to B position. Repeat this step if partial knitting has been worked on both sides.

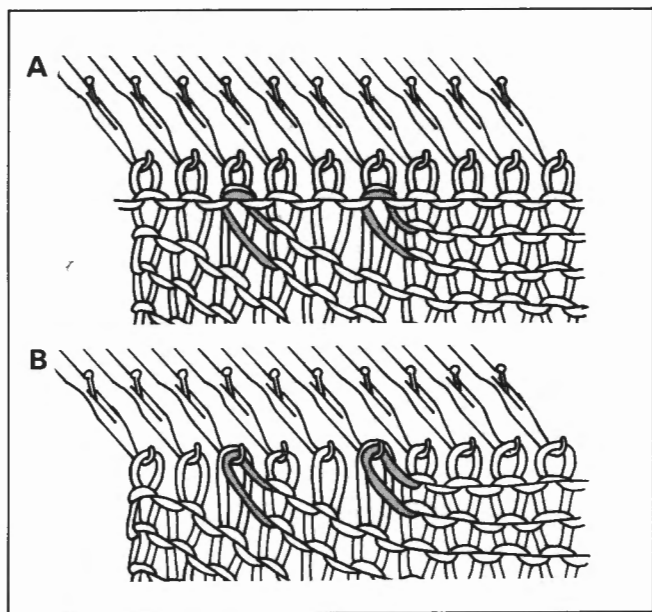

B. Pattern knitting

Using a Transfer Tool, return the needles in D position to B position, on the opposite side to the Carriage.

Knit 1 row.
Repeat this step if partial knitting has been worked on both sides.

Increasing stitches

Set the Russel Levers to the "I" position.

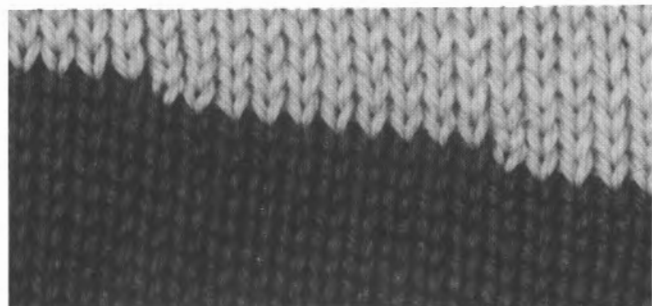

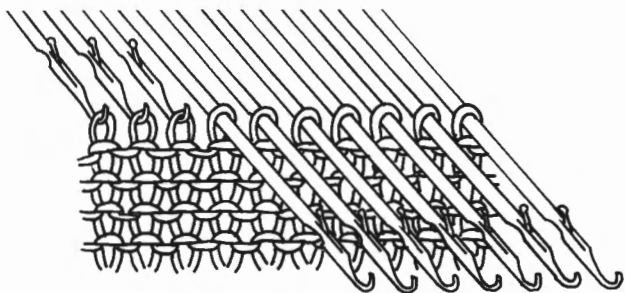

1. Push the required number of needles opposite the Carriage to D position.

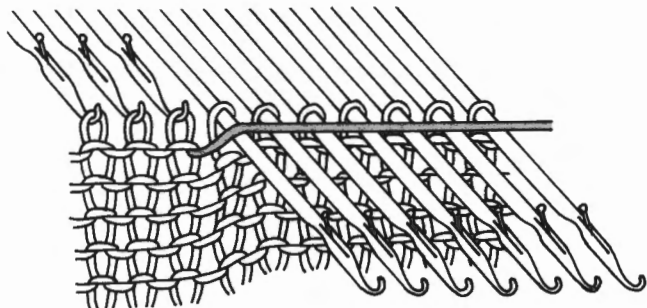

2. Knit 1 row.
(The needles in B position knit the yarn. The needles in D position remain inactive and the yarn passes over them.)

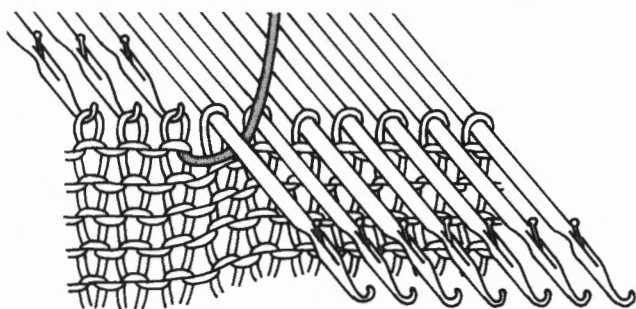

3. To prevent a hole forming, pass the yarn under the first inside needle in D position and over the remaining needles. (If partial knitting is required on both sides, repeat step 1 before knitting next row.)

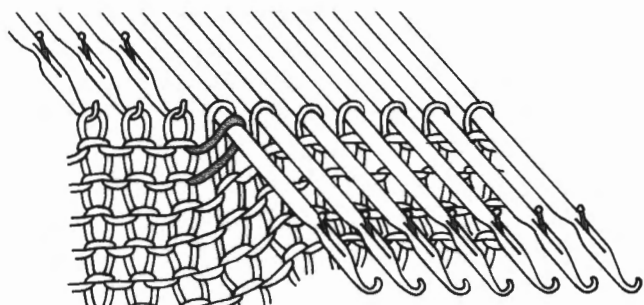

4. Knit 1 row.
(If partial knitting is required on both sides, repeat step 3.)

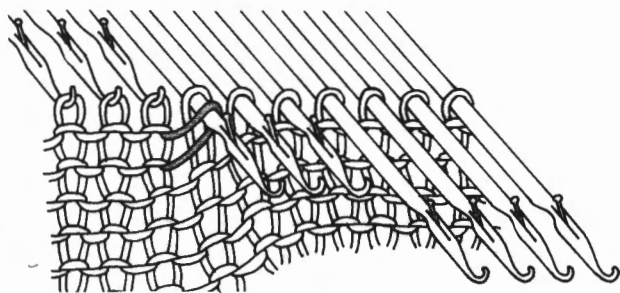

5. On the side opposite the Carriage, push the needles to be increased back to C position.

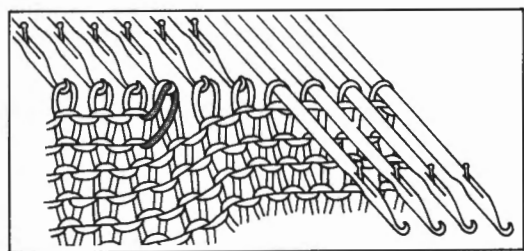

(In case of the pattern knitting, push the needles to be increased to B position with a Transfer Tool.)

6. Repeat Steps 2 ~ 5.
(If partial knitting has been worked on both sides, repeat steps 2, 3 and 5 only.)

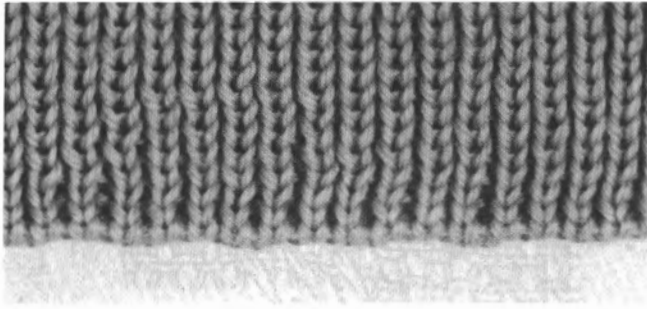

K1.P1. Rib.

If you don't have a Ribber, this method of knitting ribs can be used for knitting cuffs, neckbands and welts.

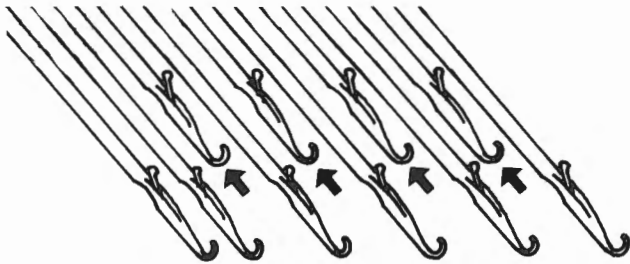

1. Push the required number of needles to B position. Push back every alternate needle to A position, starting with the third needle from the left side.

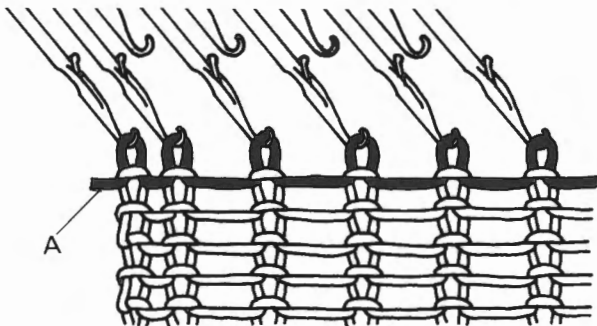

2. Cast-on and knit several rows with the waste yarn. Hang Claw Weights at both edges of knitting. Knit 1 row with Ravel Cord "A".

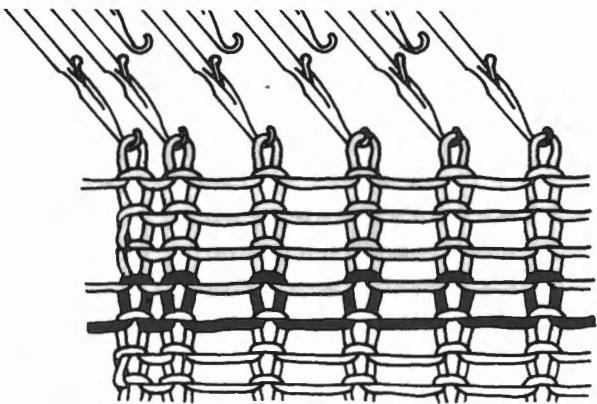

3. Thread the main yarn and knit 4 rows with Stitch Dial at R.

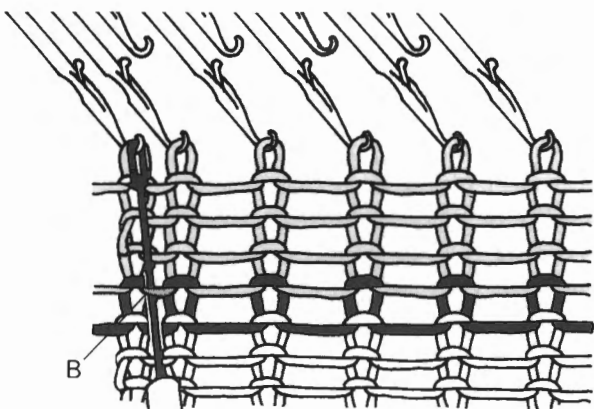

4. Insert the Transfer Tool into the left end sinker loop "B" on the first row of the main knitting. (Above the Ravel Cord)

5. Place the loop onto the end needle. Push the needles that are in A position, to B position.

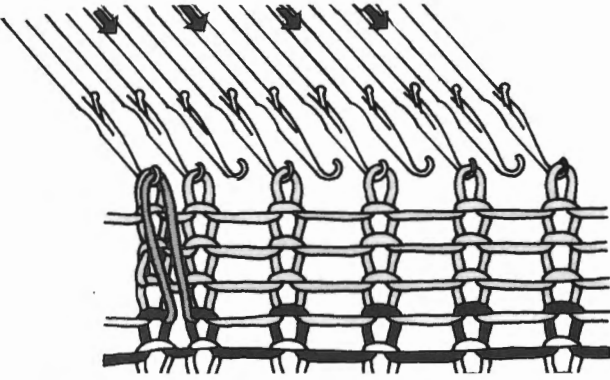

6. Knit the length required for ribbing with the Stitch Dial 2 numbers lower than for Stockinet.

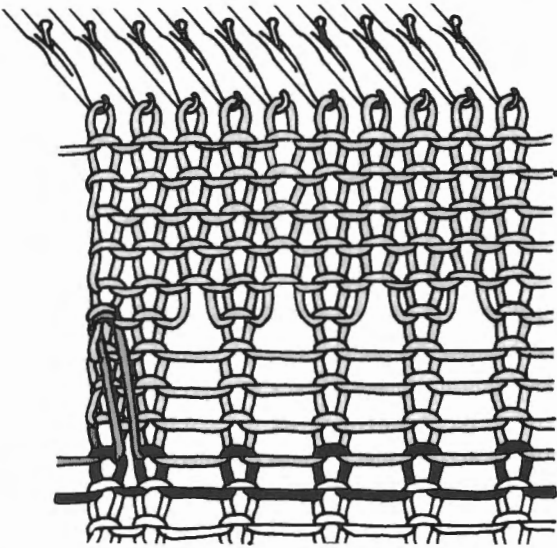

7. Insert the Tappet Tool into the loop of the first row of main knitting and unravel the stitches as shown. Skip over the next 3 rows and catch the yarn on 5th row crossing above, in the hook of the Tappet Tool.

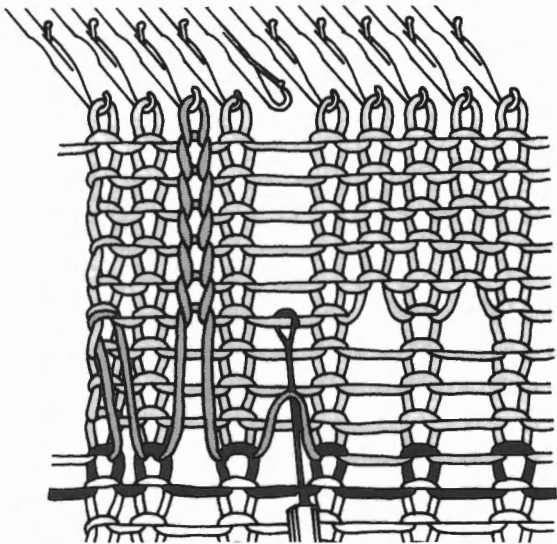

8. Pull the Tappet Tool towards you. The first stitch will slip off the Tappet Tool, forming a new stitch.

9. Catch the yarn on the next row crossing above and pull the Tappet Tool towards you.

10. Repeat step 9 for every row. Place the last stitch back onto its needle. Reform every alternate stitch as above.

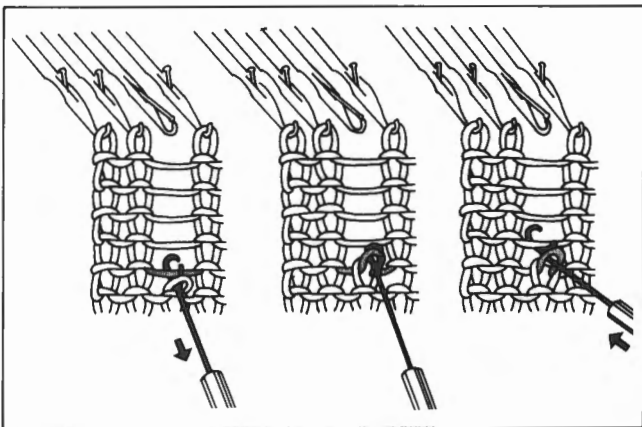

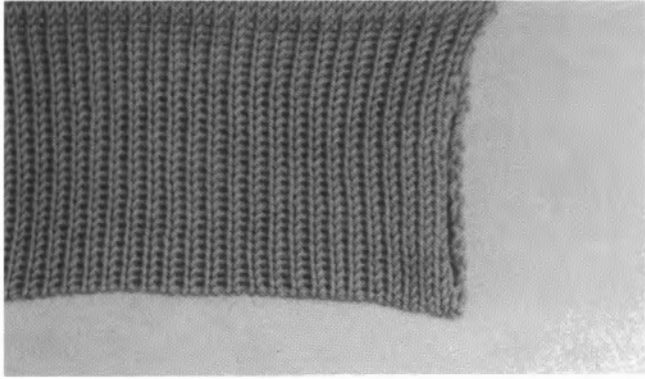

Mock Rib.

Mock Rib. can be used instead of K1.P1. Rib..

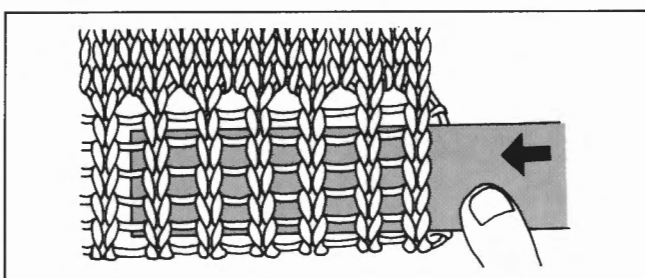
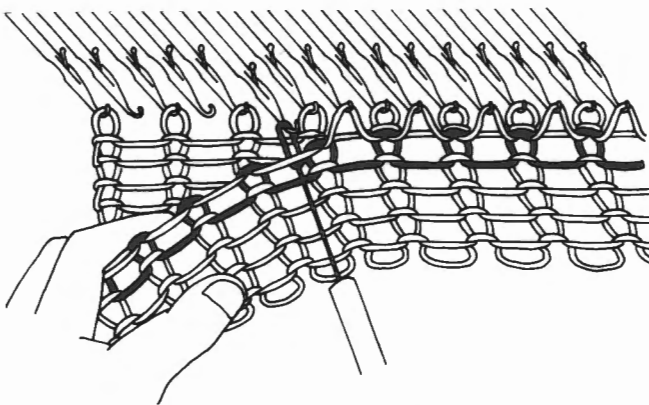
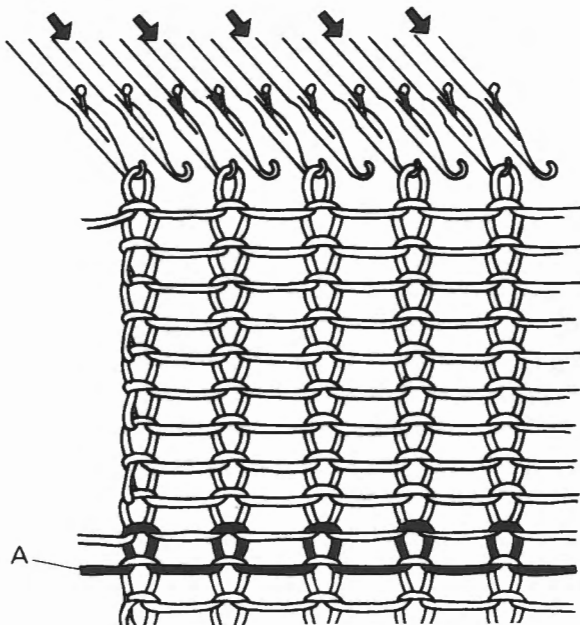
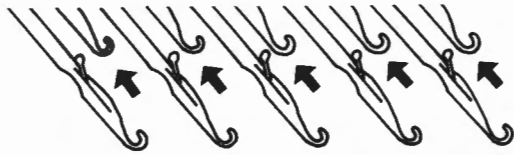

1. Push the required number of needles to B position and push back every alternate needle to A position starting with the second needle from the left side.
2. Cast-on and knit several rows with the waste yarn. Knit 1 row with Ravel Cord "A".
3. Thread the main yarn and set the Stitch Dial 3 ~ 4 number lower than for Stockinet, and knit twice the number of rows required for the welt.
4. Push the needles that are in A position, to B position.
5. Using Transfer Tool, pick up the sinker loops on the first row of the main knitting above the Ravel Cord and place them onto the empty needles in B position.
6. Re-set the Stitch Dial to the number used for Stockinet knitting and continue to knit. Pull out the Ravel Cord to remove the waste knitting.

When pressing, insert a ruler into the side opening of the welt and pull the knitting vertically, to close up the stitches.

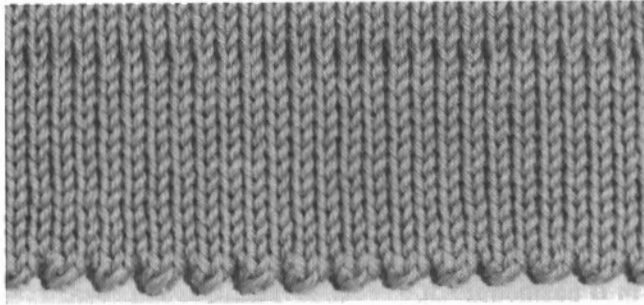

Picot Hem

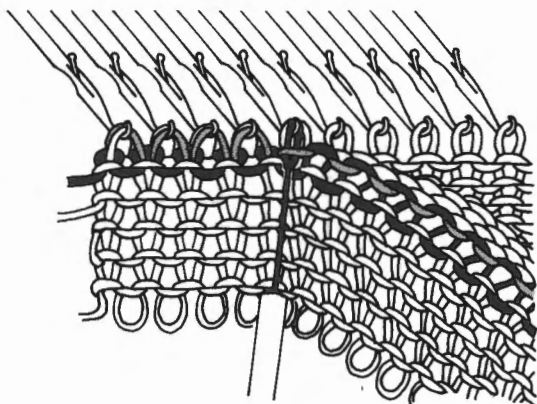
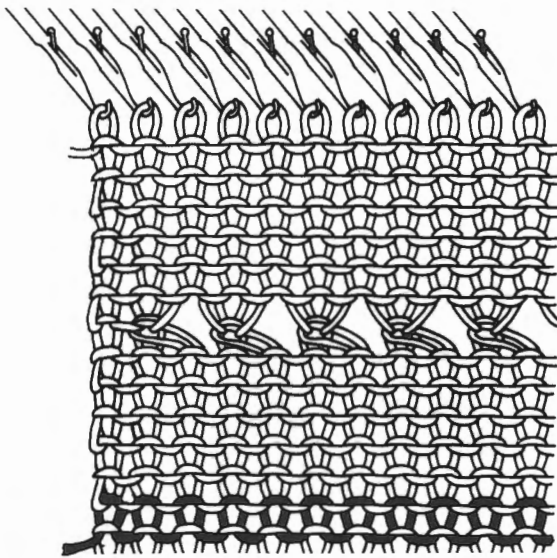
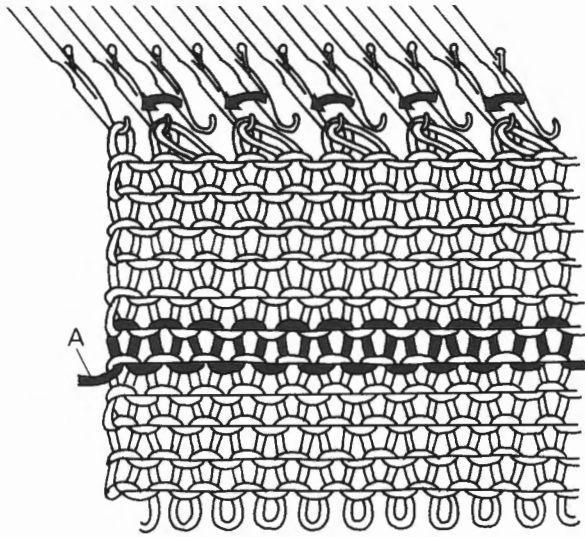

1. Arrange an even number of needles in B position. Cast-on and knit several rows with the waste yarn. Knit 1 row with the Ravel Cord "A". Set the Stitch Dial 1 number lower than for Stockinet and knit with the main yarn, 1 row less than required for the depth of the hem.

2. Make picot eyelets by transferring every alternate stitch to its adjacent needle. Leave the empty needles in B position.

3. Reset the Stitch Dial to the original Stockinet setting, and knit the same number of rows required for the depth of the hem.

4. Place the sinker loops of the first row of the main knitting onto their corresponding needles. Remember to pick up the edge sinker loop.

5. Set the Stitch Dial 2 number higher than the number originally used and knit 1 row. Pull out the Ravel Cord to remove waste knitting. Reset the Stitch Dial to the Stockinet setting and continue to knit.

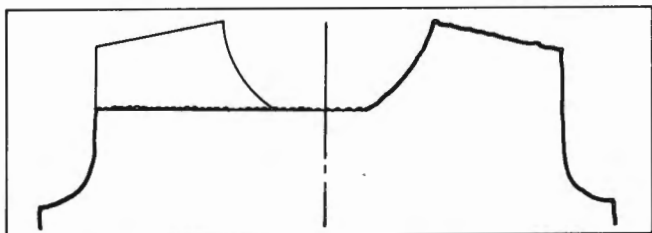

Holding stitches

If it is necessary to shape a garment in sections, use one of the following methods.

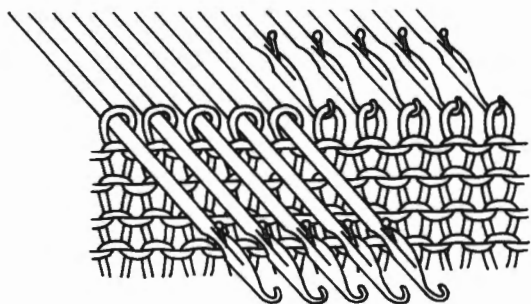

In D position

1. Push the needles for the section to be held to D position.

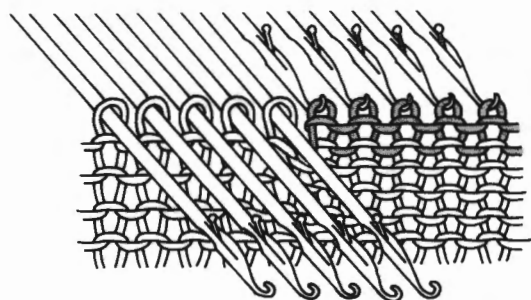

2. Set the Russel Levers to **I**, and continue to knit.

To continue knitting on the stitches which have been held, push the needles back to C position, and continue to knit. (Stockinet only)

When pattern knitting

Return the needles which have been held to B position using a Transfer Tool. Replace the stitches in the needle hooks.

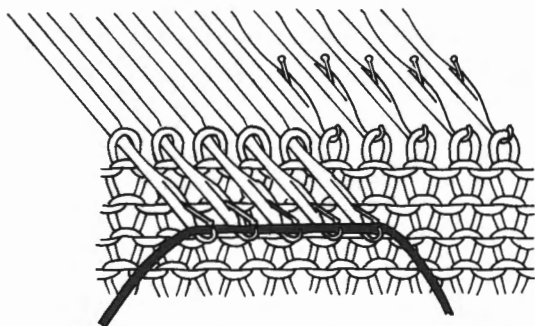

Using Ravel Cord

1. Push the needles for the section to be held to D position, and lay the Ravel Cord across the hooks.

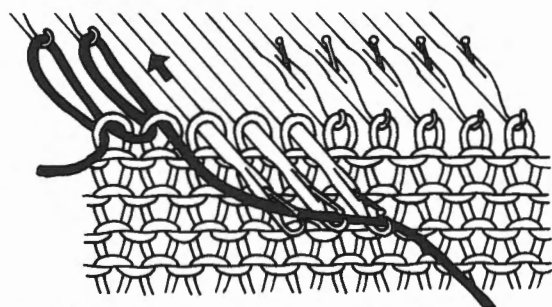

2. Starting from the end needle, push the needles back to A position manually.

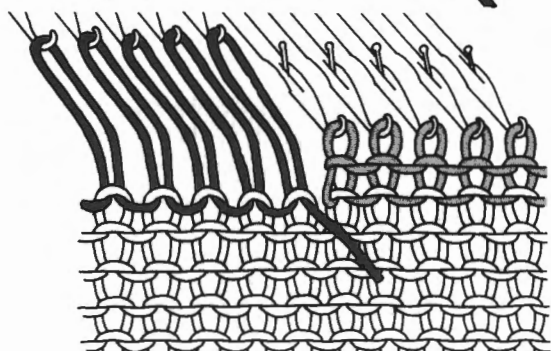

3. Continue to knit.

Before starting each row, make sure that the needles are well back in A position.

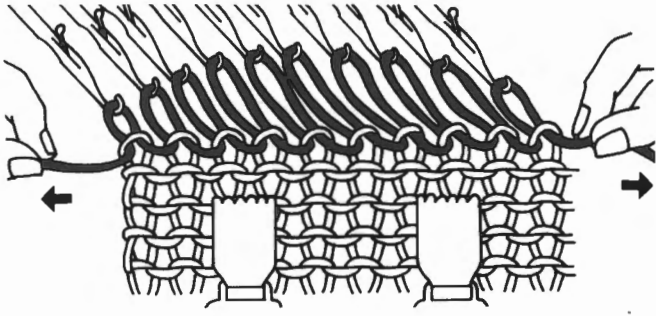

To bring the needles back into B position, pull both ends of the Ravel Cord by hands.

Note: Before pulling the Ravel Cord, hang the Claw Weights on the knitting.

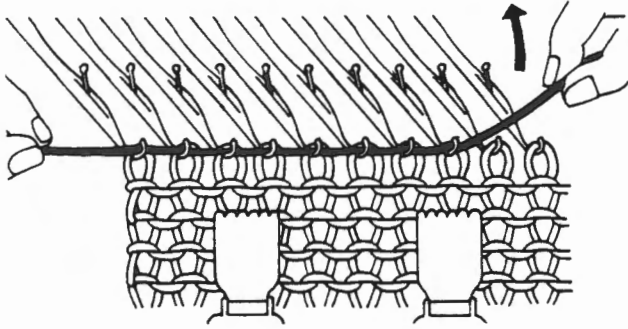

When the needles are brought to B position, hold the left end of the Ravel Cord and pull the other end in an upward motion.

The stitches are replaced in the hooks.

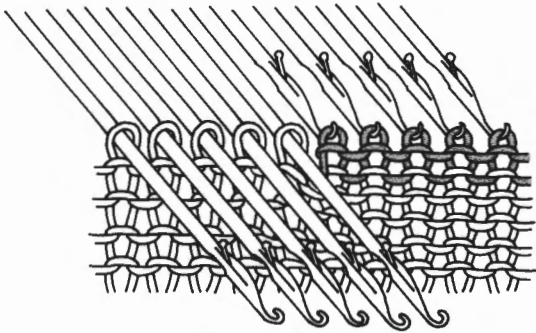

Waste yarn

Set the Cam Lever to Stockinet and the Russel Levers to I.

1. Leave the needles for the section to be removed with waste yarn in B position. Push the remaining needles to D position.
2. Thread waste yarn into the Yarn Feeder and knit several rows. Remove this section from the machine.

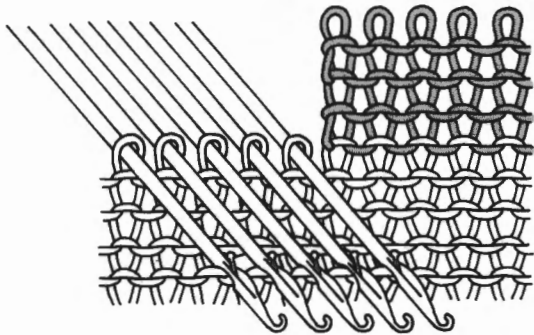

3. Push needles from D position back to C position for Stockinet, or return to B position with a Transfer Tool for pattern knitting. Reset the Carriage to the original settings and continue to knit.

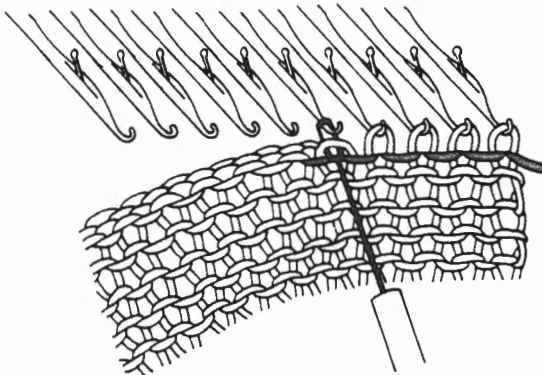

To continue knitting the stitches held on waste knitting, pick up the stitches on the last row of the main knitting and place them onto the corresponding needles.

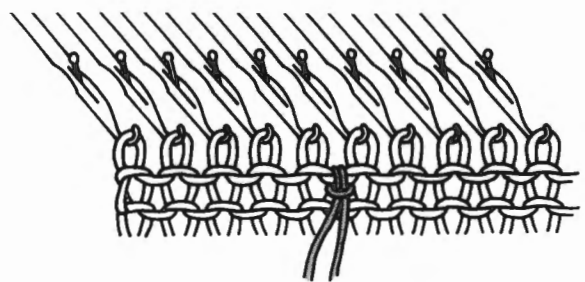
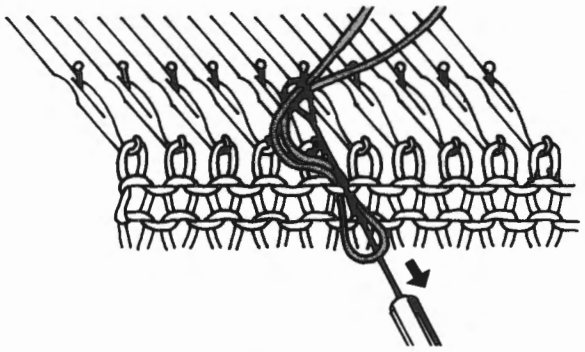
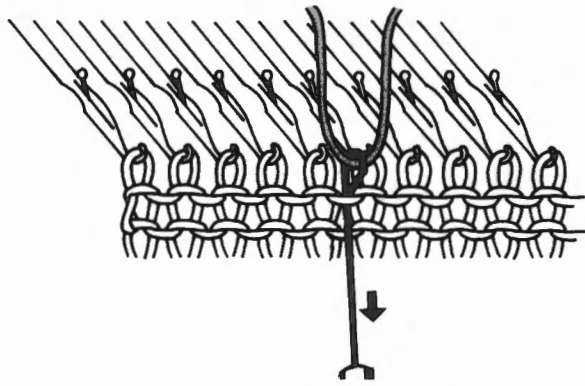

To make yarn mark

Insert the Tappet Tool into the sinker loop to be marked.
Take a length of waste yarn and make a loop on the Tappet Tool.
Pull the Tappet Tool through the sinker loop.

Catch both ends of the waste yarn and pull out the Tappet Tool through the loop.

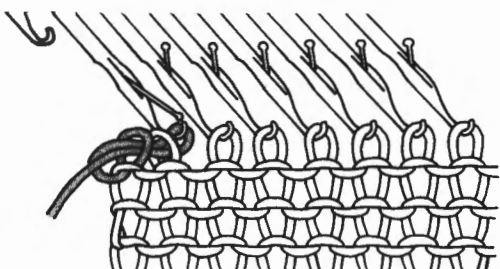
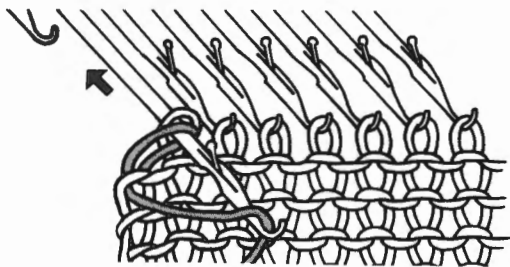
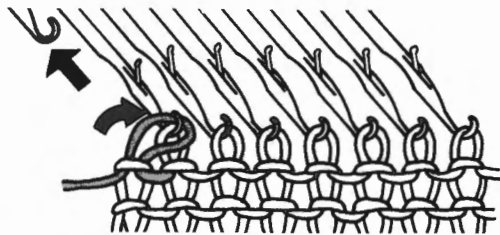

To cast off with Transfer Tool

Knit last row and break the yarn leaving the end 3 times the width of the knitting.

1. Transfer the first stitch to the second needle and push the empty needle back to A position.
2. Push the second needle to D position so both stitches are behind the latch and lay the yarn in the needle hook.
3. Push the needle back to B position.
4. Repeat steps 1 ~ 3.

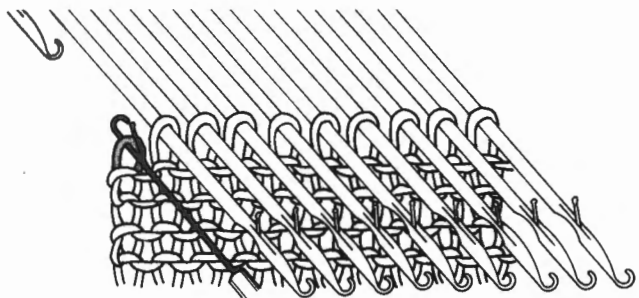

To cast off with Tappet Tool

This is used to make a closed edge when knitting is completed.

1. Knit the cast off row, setting the Stitch Dial 3 ~ 4 numbers higher than the main tension. Push the needles to D position. On the side opposite the Carriage, catch the first stitch with the Tappet Tool and push the needle back to A position. The stitch is transferred onto the Tappet Tool.

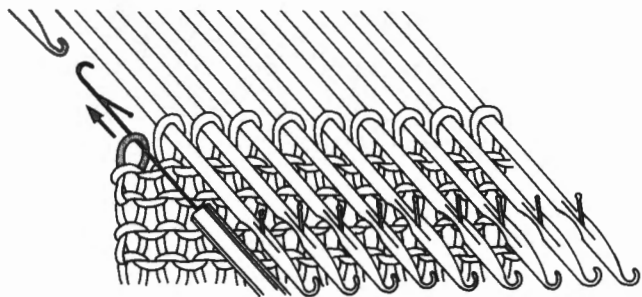

2. Push the stitch behind the latch of the Tool.

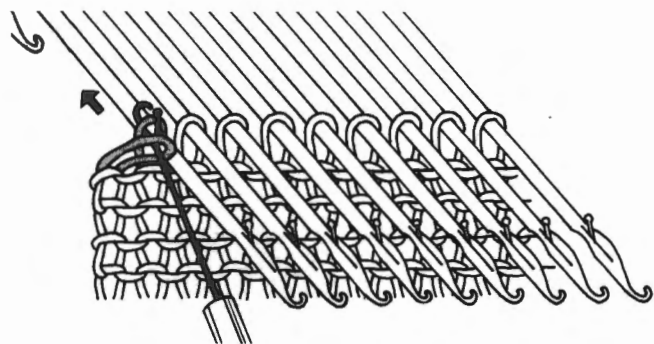

3. Catch the second stitch. Push the needle back as indicated by the arrow but pull the Tappet Tool in the opposite direction.

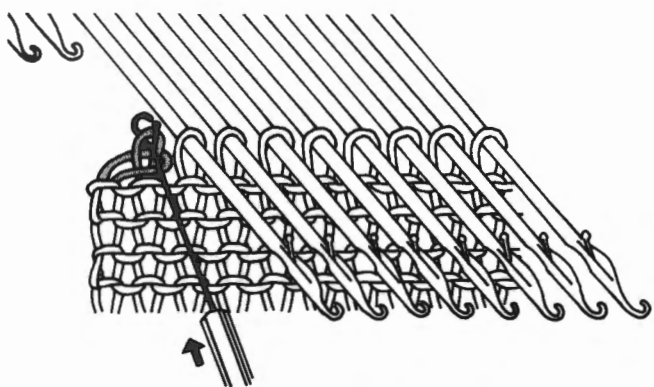

The first stitch will slip off the tool, leaving the second stitch in the hook of the Tappet Tool.

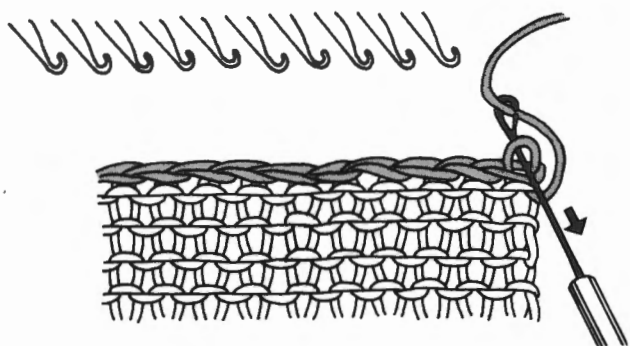

4. Repeat steps 2 ~ 3.
Cast off the last stitch by pulling the yarn end through the stitch with the Tappet Tool as shown.

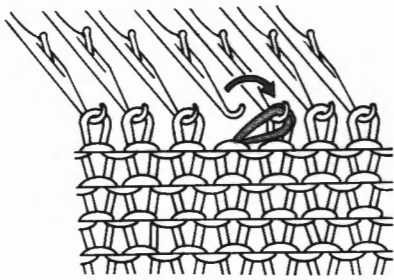

To make a buttonhole by transferring stitches

1. Place 1 stitch onto its adjacent stitch.

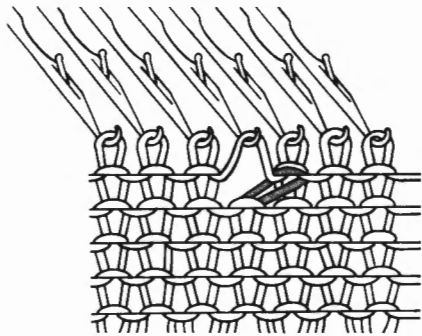

2. Knit 1 row so that a hole is formed.

3. Continue to knit.

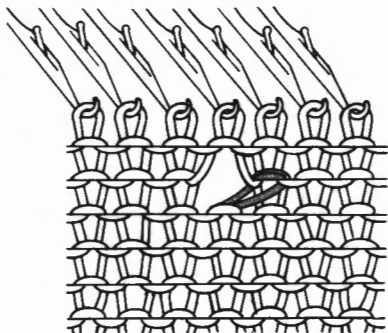

Applying buttonhole method, openwork can be formed.

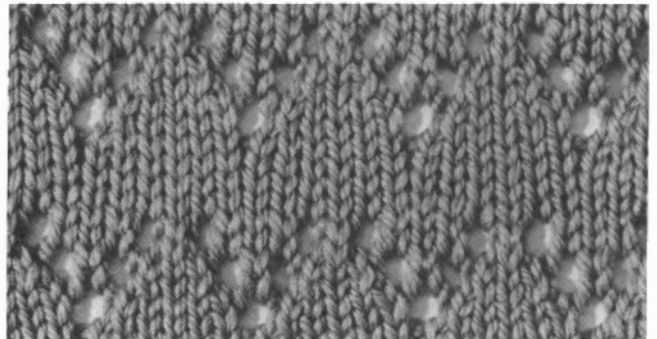

K1.P1. Rib.

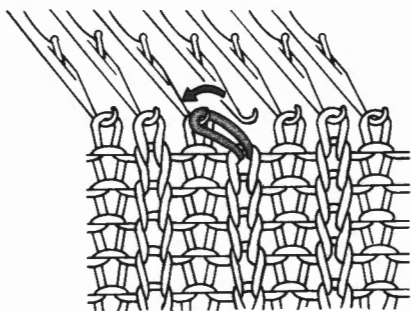

1. Reform the stitch for K1.P1. Rib. and place the reformed stitch onto its adjacent needle.

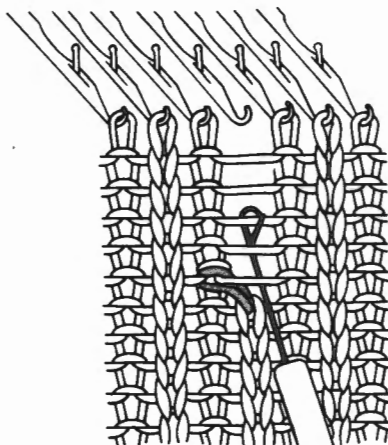

2. With the empty needle in B position, continue to knit. Unravel the row and insert the Tappet Tool behind the first two rows and hook the third row.

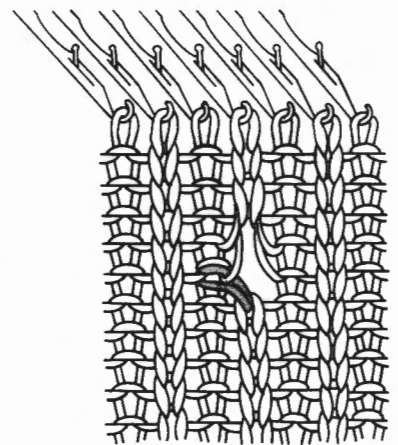

3. Continue to reform the stitches for K1.P1. Rib. Use the side as wrong side.

Seaming on the machine

Stitch to stitch

This is used for joining shoulders etc..

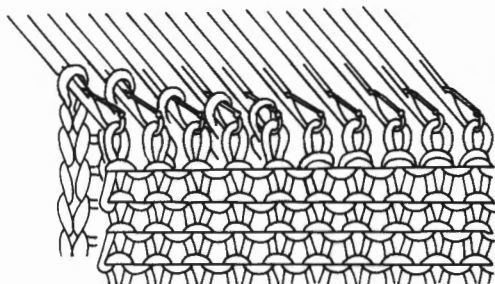
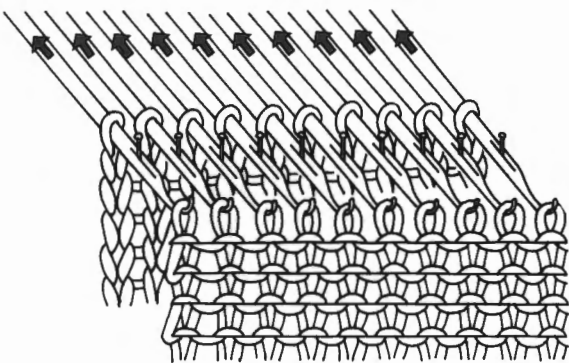
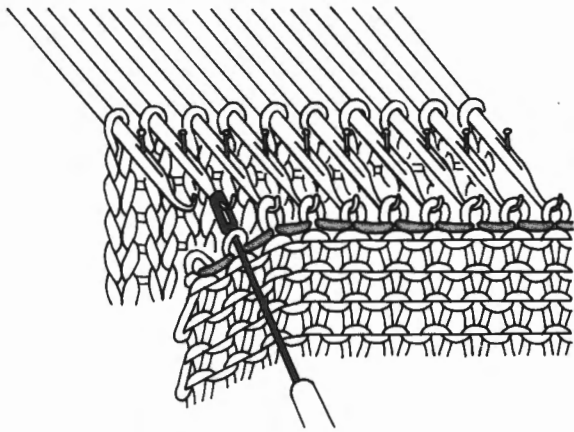
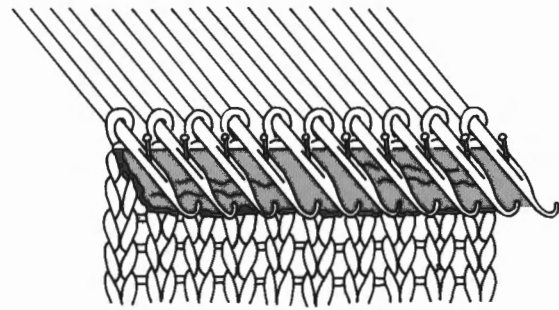
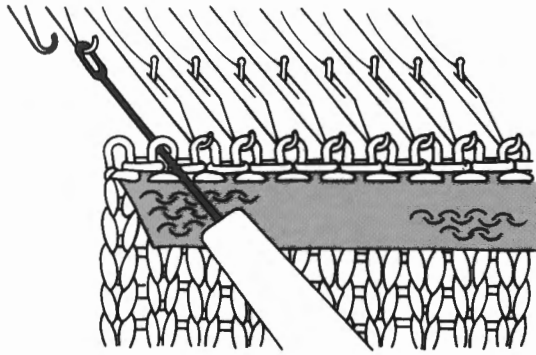

1. With the right side of the first knitting facing you, pick up the stitches on the last row of the main knitting and place them onto the needles.

2. Push the needles to D position and bring the stitches of the knitting behind the latches.
Unravel the waste knitting

3. With the wrong side of the second knitting facing you, pick up the stitches on the last row of the main knitting.

4. Push the needles towards B position.

5. The rear stitches will slip off the needles and interloop with the front stitches.
Unravel the waste knitting.

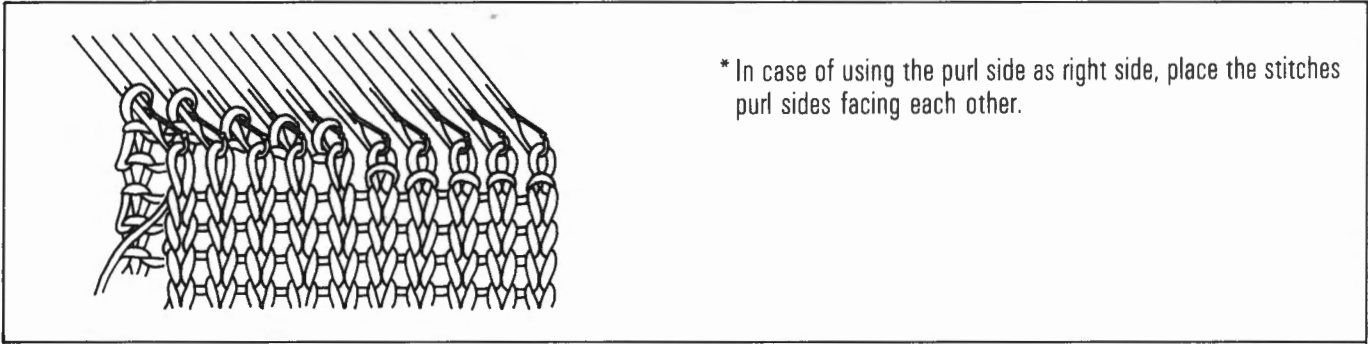

* In case of using the purl side as right side, place the stitches purl sides facing each other.

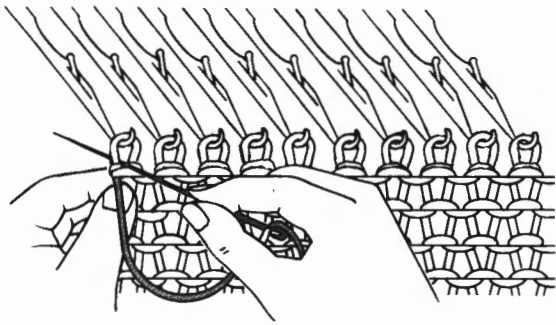

6. Cast off the stitches by using the Back Stitch Method.

(1) Thread the Tapestry Needle and insert it into the first stitch and pull the yarn.

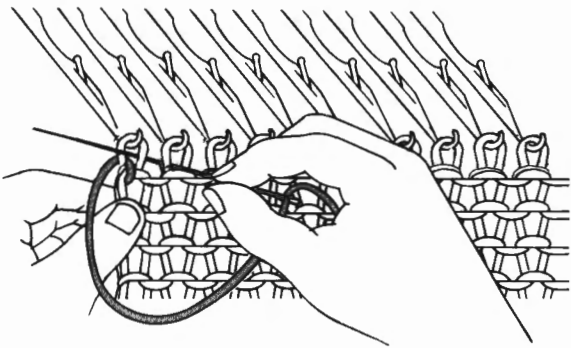

(2) Insert the Tapestry Needle through the second stitch and pull out from the first stitch.

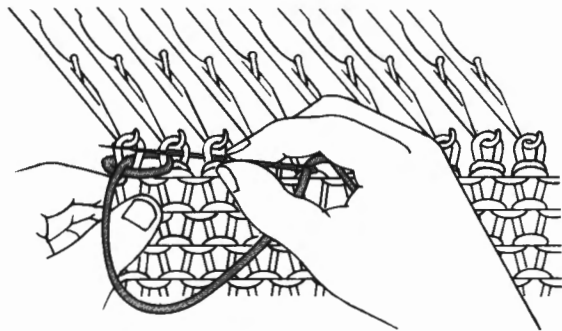

(3) Insert the Tapestry Needle through the third stitch and pull out from the second stitch.

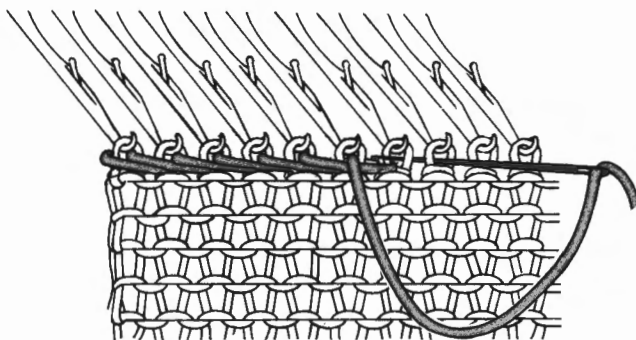

(4) Repeat steps (2) ~ (3)
 · Close the last stitch by inserting the yarn and guiding it out the stitch.

Open stitches to side edge

This is used for joining the border to the front open edge of a cardigan etc..

1. With the knit side of the first knitting facing you, pick up the stitches on the side edge, omitting a stitch at appropriate intervals, and place them onto the needles.

2. Push the needles to D position. With the purl side of the second knitting facing you, pick up the stitches on the last row of the main knitting, and place them onto the same needles.

3. Push back the needles to B position.

4. The stitches behind the latches will slip off the needles. Unravel the waste knitting.

5. Cast off the stitches using the Back Stitch Method. (Refer to page 78, step 6.)

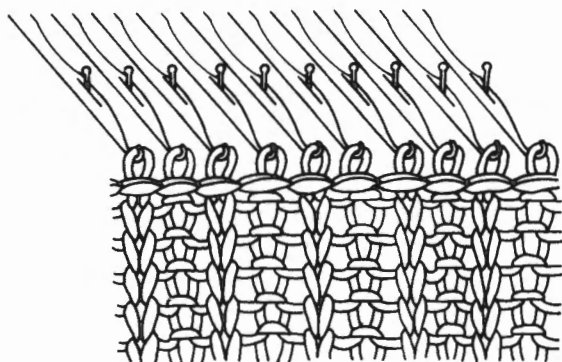
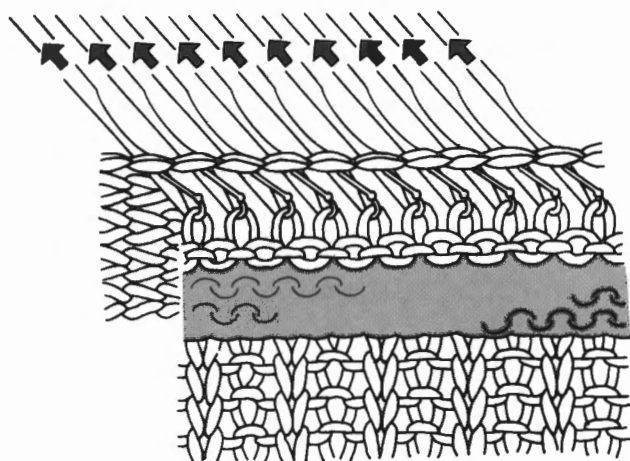
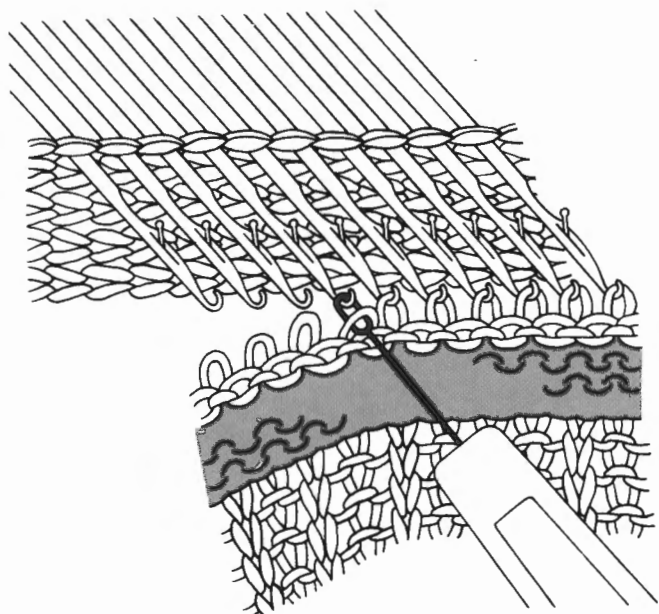
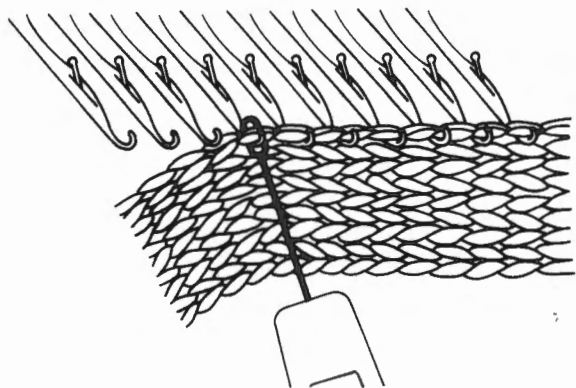

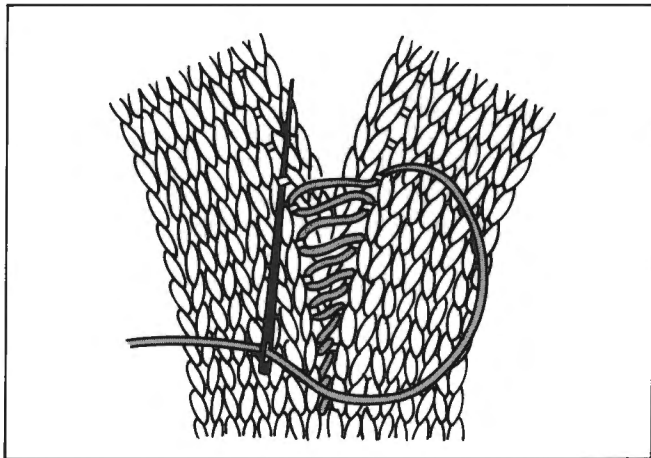

Joining by hand

Blind Stitch

This is used for joining side seams.

Use medium type yarn.

Knit side as right side:—

With the knit sides facing you, pick up each sinker loop between the last 2 edge stitches. Repeat, picking up the sinker loop from every row.

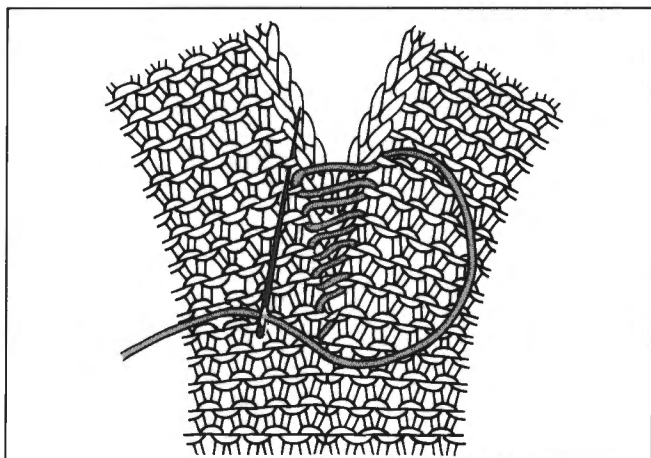

Purl side as right side:—

With the purl sides facing you, pick up each sinker loop between the last 2 edge stitches.

Repeat, picking up the sinker loop from every row.

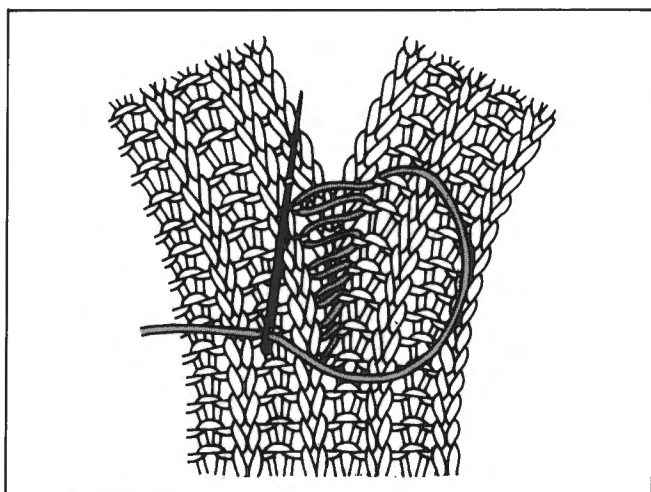

K1.P1. Rib.:—

With the side to be used as the right side facing you, pick up the sinker loops between the last 2 edge stitches.

Repeat on every row.

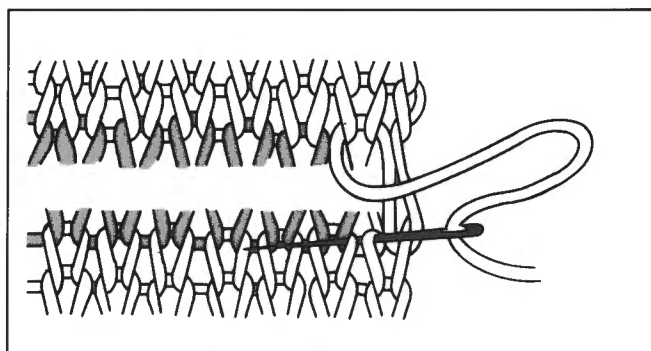

Grafting

This is used to join two open rows, where the seam should be invisible.

Align both pieces as shown and thread the knitting yarn through the stitches with the Tapestry Needle.

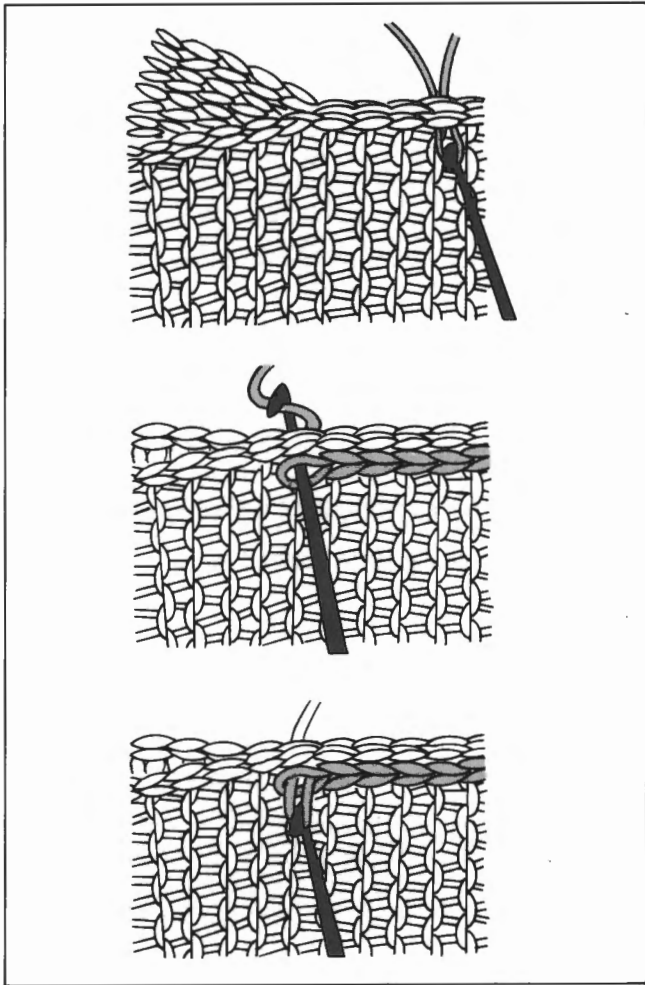

Slip Stitch

This is used for setting in the sleeves or joining side seams.

1. Place the knitting to be joined with the right sides facing each other. Insert the Crochet Hook into each sinker loop between the last 2 stitches from the side edge, catch the yarn and pull it back.

2. Insert the Crochet Hook into the next loop and catch the yarn.

3. Pull back the Crochet Hook.

Repeat steps 2 ~ 3.

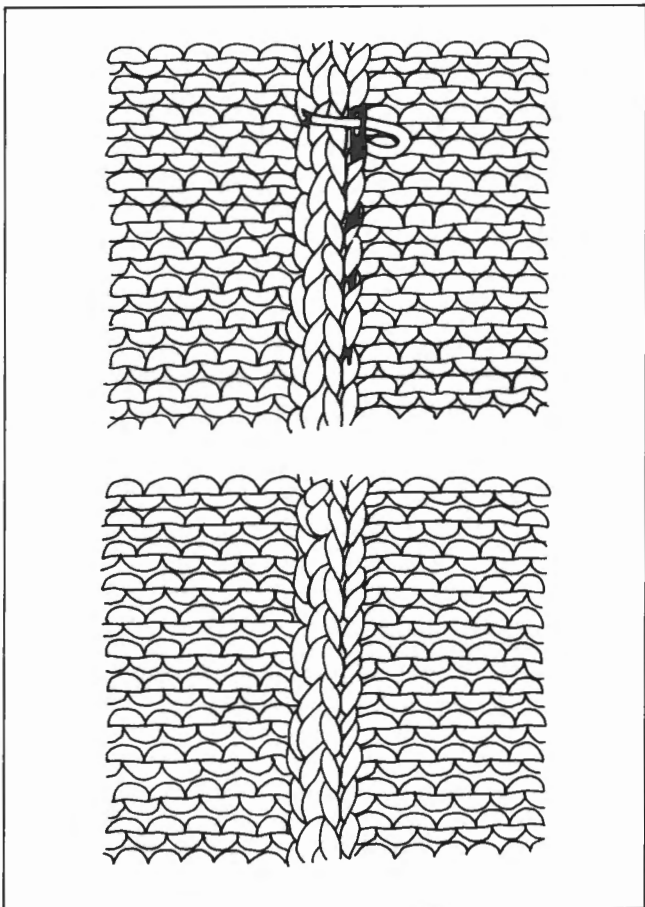

Sewing in yarn ends

Thrust the Tapestry Needle into the seamed ridge, thread the yarn end through the eyelet of the Tapestry Needle and sew in the yarn end into the ridge.

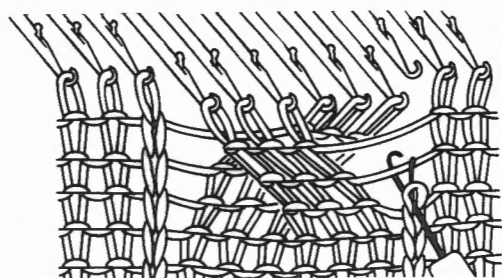
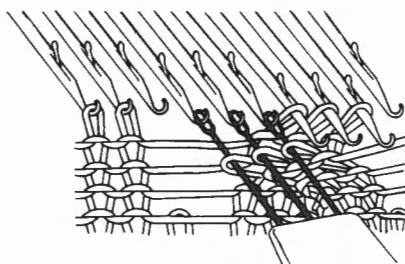
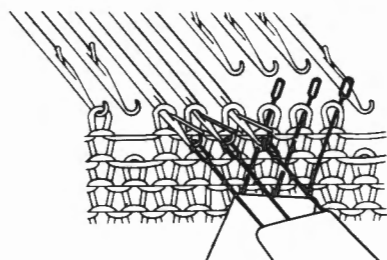
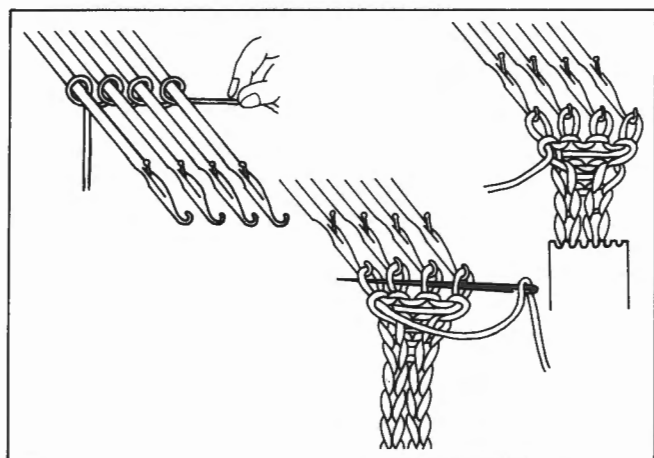
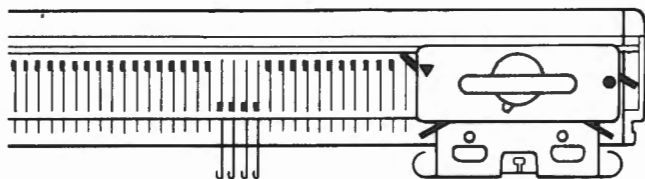

Cord Knitting

1. Place the Carriage on the right side of the Needle Bed and set the machine as follows.

Cam Lever..... **S** (Slip Stitch)
 Stitch Dial..... lower than Stockinet
 Side Lever..... ▼ (left), ● (right)
 Russel Levers..... **II**
 Weaving Knobs..... ○

2. Depending on the thickness of the cord, bring 3 ~ 5 needles to D position. Cast-on using the winding method as illustrated.
3. Move the Carriage back and forth five times, then hang Claw Weight.
4. Continue until the desired length has been knitted.
5. Cut the yarn, leaving 10cm.. Cast off with a Tapestry Needle.

Cable Pattern

Cable patterns are formed by crossing one group of stitches over a second group of stitches using two Transfer Tools.

Try a six stitch cable.

1. Drop one stitch on both sides of the 6 stitches to be cabled. Using two 3-prong Transfer Tools, remove the 6 stitches from their needles.
2. Cross the two Transfer Tools and replace each group of 3 stitches on their new needles.
3. Reform the dropped stitches using the Tappet Tool and replace them onto their original needles.

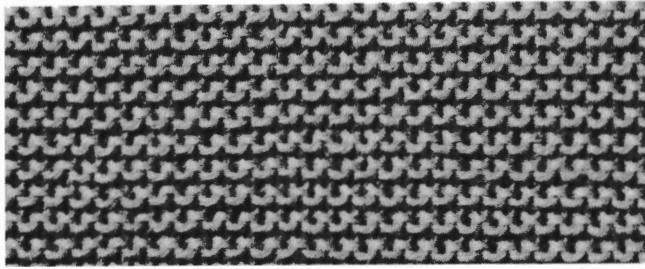

Garter Stitch

Garter Stitch can be used for laps, collars, borders, etc.
Knit Stockinet, purling the stitches every alternate row.

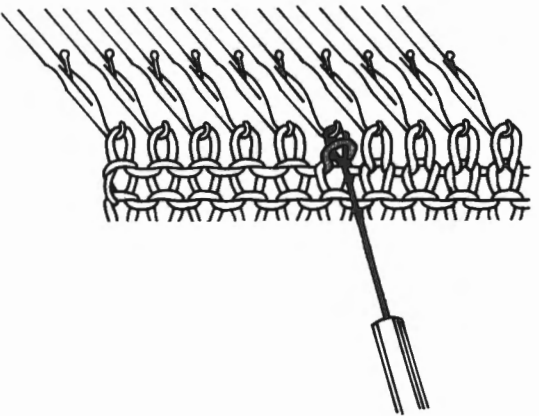
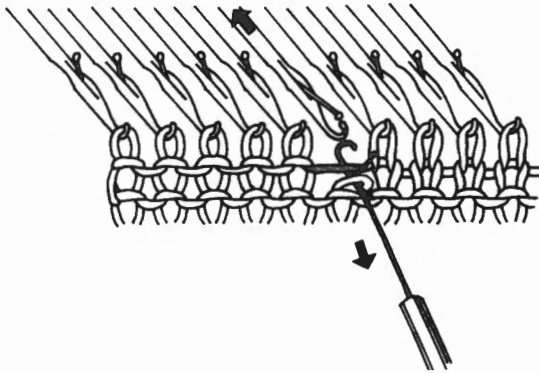

1. Set the Stitch Dial 2 numbers lower than for Stockinet knitting. Knit 2 rows Stockinet.
 2. Insert the Tappet Tool into the stitch below the stitch on the needle, and push the needle to D position.
 3. Push the needle back to B position, allowing the stitch to come undone. Catch the loop in the hook of the Tappet Tool, and pull the loop through the stitch already on the Tappet Tool.
 4. Place the new stitch back on the needle.
- Repeat steps 2 ~ 4 for all stitches on the row.
5. Knit 2 rows Stockinet and reform the stitches on the second row following steps 2 ~ 4.

Blocking and pressing

After knitting the pieces of your garment, you must lay them flat and pin them out to their correct shape and size.

1. Pin out a piece with the wrong side up on an ironing board. Pin the widest part of the piece first, then measure and pin to the correct length.
2. Pin all around the edges, spacing the pins about 2 ~ 3cm. apart. (Place the pins inside the ribbed edge.)
3. Press lightly with a steam iron according to the spinner's instructions on the yarn band.
4. Leave the pieces to dry before removing the pins.

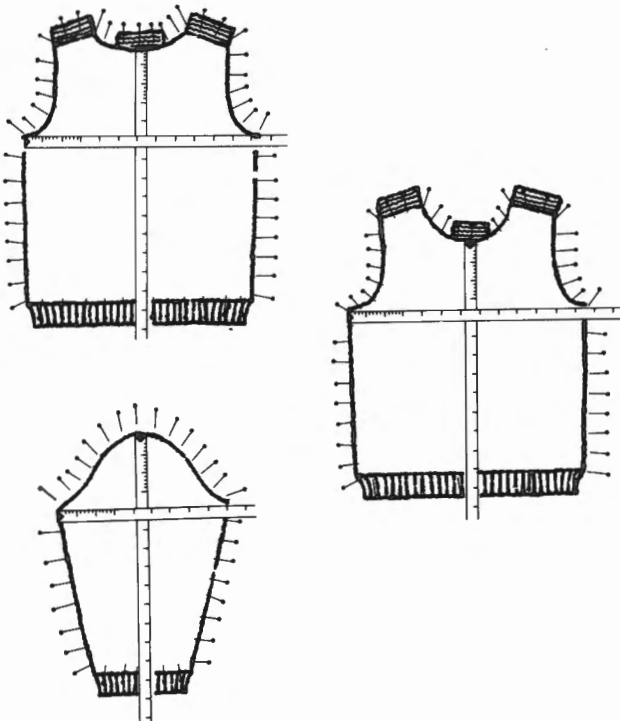

OPTIONAL ATTACHMENTS

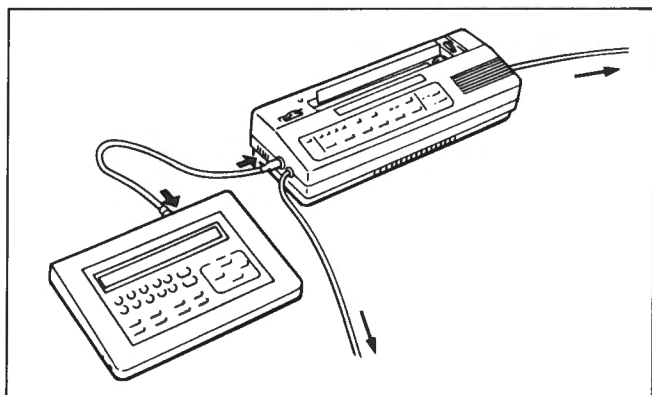

Design Controller, PE 1

By using the Design Controller, you can knit a much larger pattern than the 150 rows by 60 sts. that fit on a single Pattern Card, and multi-colour Jacquard. You can also store patterns in a Memory Card.

Plug the connection cord into the socket at the top of the Design Controller and on the left side of the Pattern Controller.

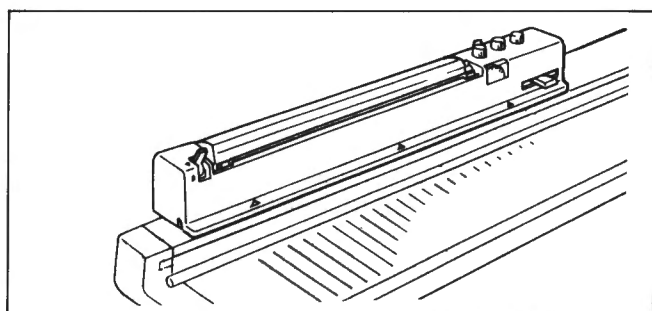

Knit Contour (Radar)

This Knit Contour tells you how many stitches to increase or decrease, where to increase or decrease and how many rows to knit for shaping garments. So, this is very useful attachment.

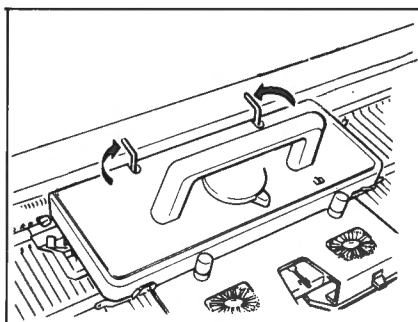
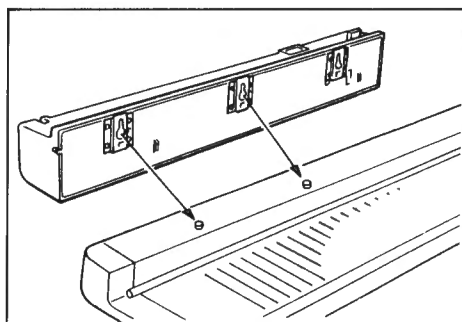

KR 7 (Mechanical-feed Knit Contour)

Fit the left 2 slots of the Knit Contour into the studs on the top of the machine and slide it towards back until click.

If the tension gauge is less than lowest limit 30 rows, select a number twice the row number read on the Gauge Scale and raise both Feeding Trippers on the Carriage.

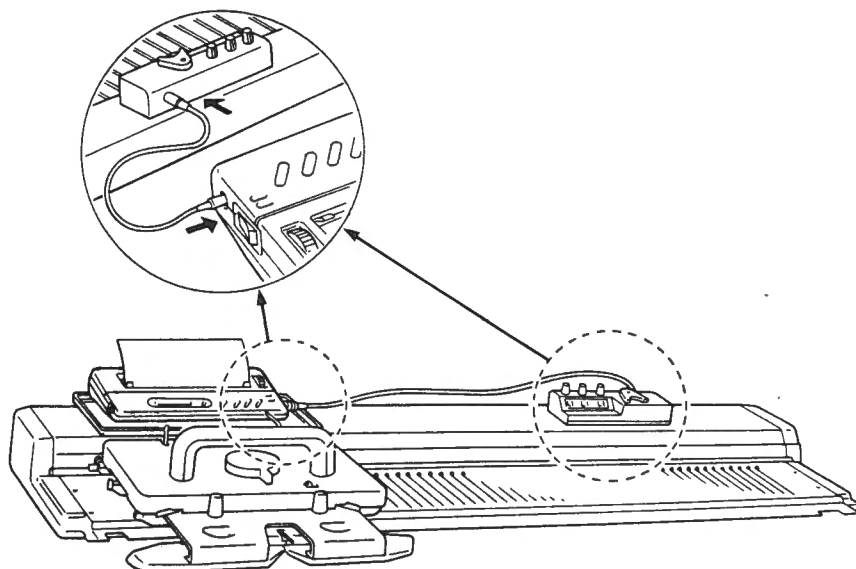

KR 10 (Electronic Knit Contour)

Plug the connecting cord into the sockets at the top of the Row Counter and on the right side of the Knit Contour.

Use the lid of the Accessory Box as a tray for the Knit Contour by fitting it into the studs on the top of the machine. Put the Knit Contour 2cm. apart from this side's edge of the tray.

**TO USE THE CHUNKY RIBBER,
SR 155**

CONTENTS

	page
POINTS TO NOTE	86
OPERATION TABLE.....	87
PUNCH PIN TUCK	89
SLIP RIB	90
DRIVE LACE	91
DOUBLE JACQUARD	94
HELPFUL HINTS TO KNIT RIB. STITCHES USING PATTERN CARDS	96

This section is explaining only about the way to knit Rib. Stitches using Pattern Cards. Follow an Instruction Book supplied with the Chunky Ribber, SR 155, except the contents above.

POINTS TO NOTE

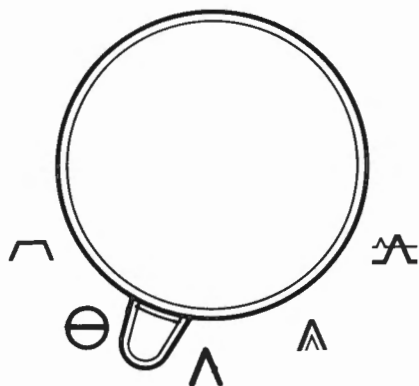
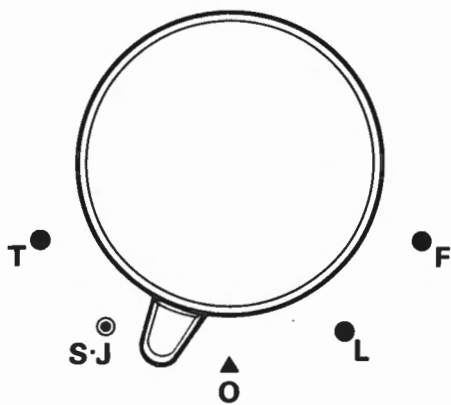

The Ribber Instruction Book assumes that you have a punch card machine, SK 155. So you need to know what is different about the use of the Ribber on your machine. There are only two small points of difference as explained next.

Cam Lever Positions

The expressions of the Cam Lever positions are different between your machine and the punchcard machine. Your machine has letters round the Stitch Dial, but no symbols. In the Ribber Instruction Book, the symbols are used in the Operation Tables and the other explanations. The left sketches show the Cam Lever positions on your machine with letters and the punchcard machine with symbols. So you will find out the difference between them.

Refer to the following and set the Cam Lever to each position.

- △ → O..... STOCKINET, CAST-ON
- ⊖ → S.J..... SLIP STITCH, DOUBLE JACQUARD

The Cam Lever should never be set to TUCK STITCH, PUNCH LACE or FAIR ISLE, when using the Ribber.

	①	②	③	④	⑤	⑥	⑦	⑧	⑨	⑩	⑪	⑫	⑬	⑭	⑮	⑯	⑰	⑱	
↓		⊖	⊖	⊖															
●	1	●	S	●	⊖	△	⊖	●	⊖	⊖	=	1	0	1	=	⊖	H-3		
2																			—
3																			
4												0		0					←
5																			→
6																			←
7																			
●	1	▼	S	▼	⊖	△	⊖	▼	1	=	1	0	1	=	1	H-3		→	2
2																H-4		→	2

(Operation Table on page 10 of the Ribber Instruction Book)

Operation Table

(To knit Rib. Stitches without using Pattern Cards.)

Your machine doesn't need the settings of column ②, ③ and ④ on the Operation Tables of the Ribber Instruction Book. These three settings are for the punchcard machine. The other settings are the same as for your machine. So follow each Operation Table on page 10 ~ 34 of the Ribber Instruction Book to knit Rib. Stitches without Pattern Cards.

(To knit Rib. Stitches using Pattern Cards.)

When you want to knit PUNCH PIN TUCK, SLIP RIB., DRIVE LACE and DOUBLE JACQUARD, connect the Pattern Controller to the machine as instructed on page 22 and refer to the Operation Tables on the following pages. Copy each pattern of page 95 onto your Design Card (transparent card), and use them instead of Punch Cards supplied with the Ribber.

OPERATION TABLE

To cast-on and knit Rib. Stitches using Pattern Cards, Operation Table gives settings and operation of machine.

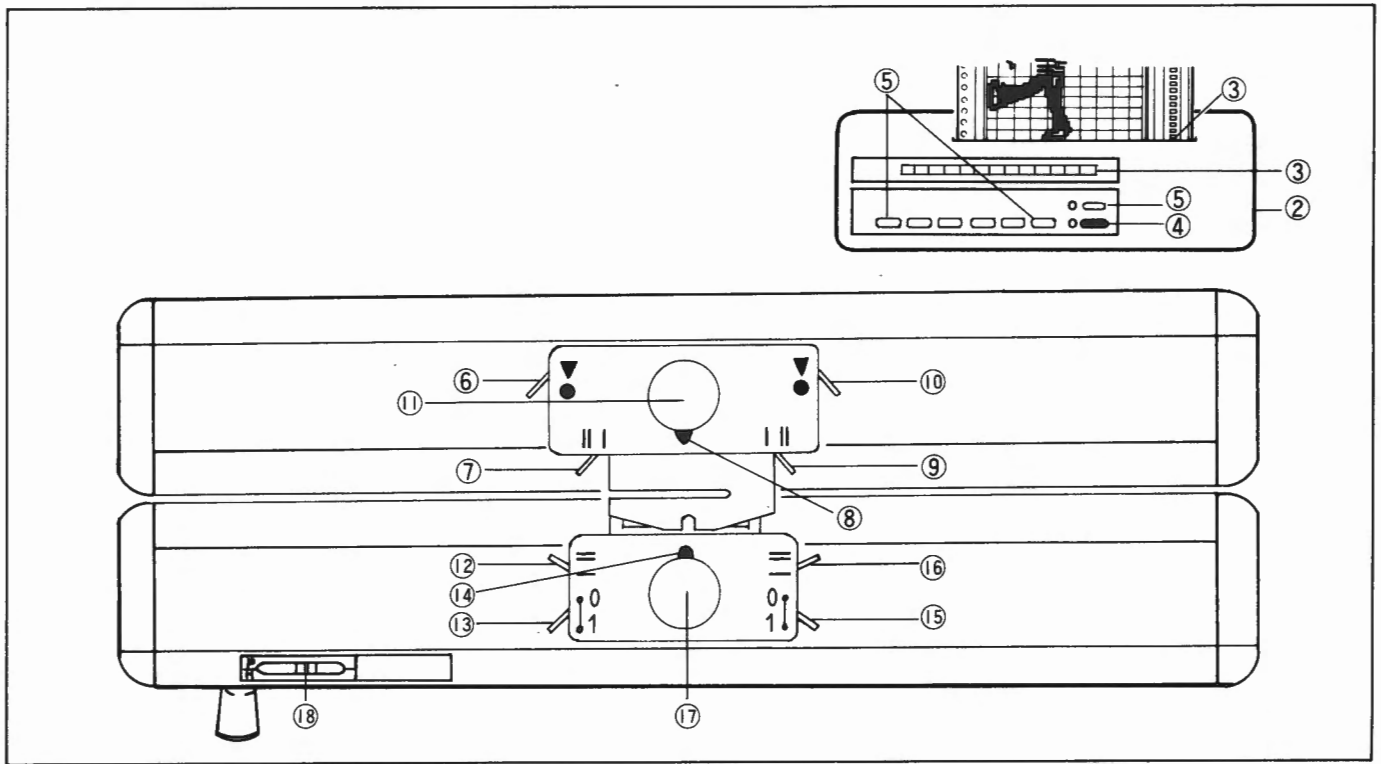



Relate the every operating parts of the machine, numbered as above, with the each column of the Operation Table below for their settings at each step of knitting.

	①	②	③	④	⑥	⑦	⑧	⑨	⑩	⑪	⑫	⑬	⑭	⑮	⑯	⑰	⑱	⑲
1	↓			●	●		○		●	Ⓜ	=	1	○	1	=	Ⓜ	H-3	
2																		→
3																		
4										0		0				0		←
5							S											→
6							O											←
7	Set the Pattern Switch as instructed.																	
8																		
②			⊙	▼		○		▼	3		1					3		↔

How to read Operation Table

	①	Procedural order of the Operation Table	
PATTERN CONTROLLER	②	ON-OFF Switch	■ — Turn on the Pattern Controller
	③	Pattern Card & Pattern Width Indicator	↓ — Set the Pattern Card and pattern width
	④	Inspection Switch	● — Light is ON ○ — Light is OFF
	⑤	Pattern Switch & Direction Switch	Set the Pattern Switches and Direction Switch as instructed.
	⑥	Side Lever (left)	Set the Stitch Dials referring to table on page 9 of the Ribber Instruction Book.
⑦	Russel Lever (left)		
⑧	Cam Lever		
⑨	Russel Lever (right)		
⑩	Side Lever (right)		
⑪	Stitch Dial		
KNITTER CARRIAGE	⑫	Russel Lever (left)	
	⑬	Set Lever (left)	
	⑭	Cam Lever	
	⑮	Set Lever (right)	
	⑯	Russel Lever (right)	
	⑰	Stitch Dial	
RIBBER CARRIAGE	⑱	Set the Pointer at the instructed number on either "H" or "P" scale by rotating the Swing Handle.	
	⑲	Arrow mark indicates knitting direction of the Carriage.	
	⑲	Arrow mark indicates knitting direction of the Carriage.	

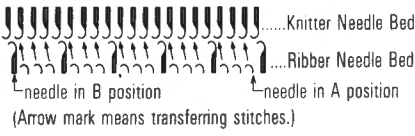
CAST-ON	①	1	Set the machine controls for initial row.
		2	Arrange needles, set Point Cams and Needle-1 Cam and knit the initial row from the left to the right.
		3	Suspend Cast-on Comb as shown in diagram and hook Weights onto Cast-on Comb. 
	4~6	Change machine controls for knitting subsequent 3 rows.	
CHANGE FOR MAIN KNITTING		7	Press the Pattern Switches as shown in diagram. 
		8	Rearrange needles for main knitting by transferring stitches. (Not necessary if needle arrangement for main knitting is the same for Cast-on.) 
MAIN KNITTING	②		Reset machine controls for working main knitting and start to knit.

PUNCH PIN TUCK

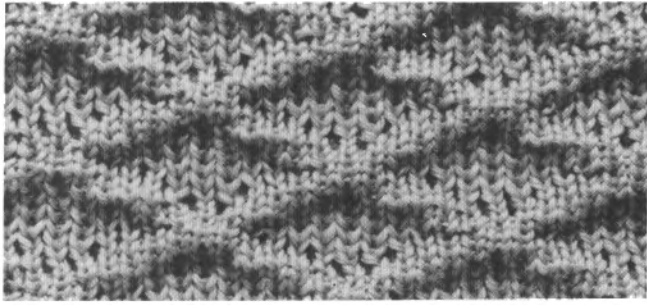

This is a variation of Pin-Tuck using Pattern Cards. Different from the ordinary Pin-Tuck knitting, curves and zigzag patterns can be knitted through brief operations. Use Close Knit Bar.

This sample is knitted with medium thick yarn using the Pattern No.2 on page 95.

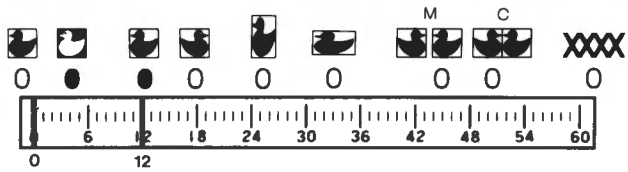

①	②	③	④	⑥	⑦	⑧	⑨	⑩	⑪	⑫	⑬	⑭	⑮	⑯	⑰	⑱	⑲
①	1	■	↓	◎	●		○		●	Ⓡ	=	1	○	1	=	Ⓡ	H-3
2																→	
3																	
4	0															←	
5	S															→	
6	O															←	
7	Press the Pattern Switch-1 to turn on the right light.																
②	◎ ▼ S ▼ 1 1 1															⇌	

Pattern No.1

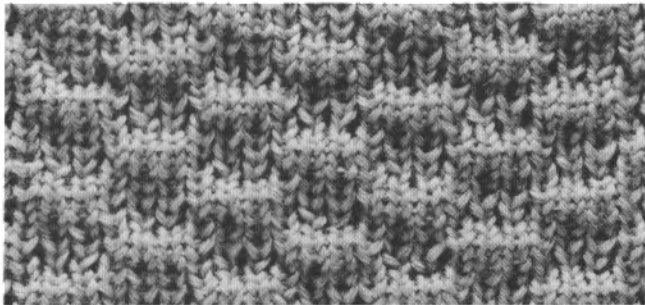

Pattern No.3

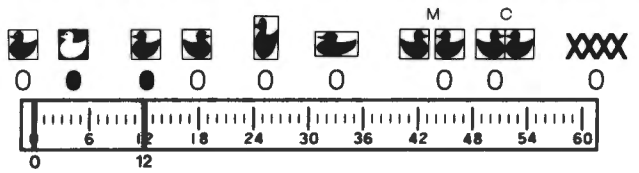
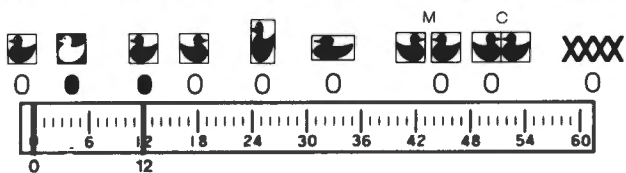
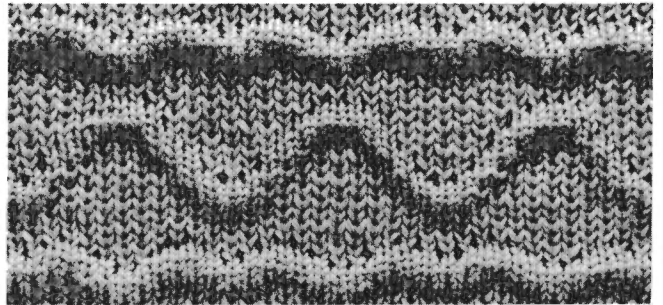

SLIP RIB.

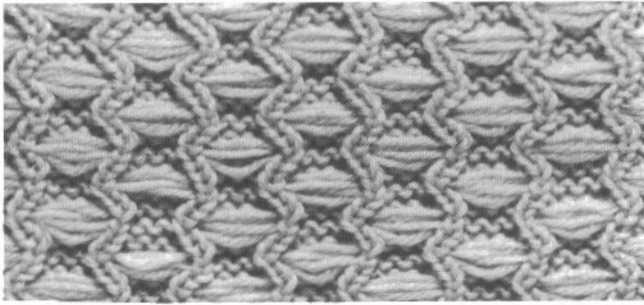

Knit in Slip Stitch using Pattern Card on Knitter, arranging needles on Ribber according to the pattern.

The sample is knitted with very thick yarn using the Pattern No. 1 on page 95.

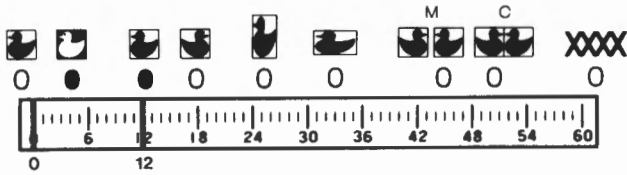

①	②	③	④	⑥	⑦	⑧	⑨	⑩	⑪	⑫	⑬	⑭	⑮	⑯	⑰	⑱	⑲	
①	1	■	↓	●	●		○		●	Ⓜ	=	1	○	1	=	Ⓜ	H-3	
2																→		
3																		
4																←		
5																→		
6																←		
7	Press the Pattern Switch-1 to turn on the right light.																	
8																		
②																↔		

Pattern Nos.2 and 3 on page 95 can be also used for Slip Rib..

(These samples are on page 93.)

Cast-on in Double Rib., and then rearrange the needles as shown before main knitting.



DRIVE LACE

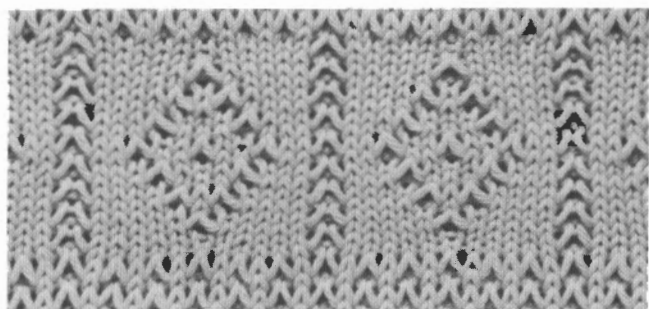

Stockinet on Ribber side, and Slip Stitch on Knitter side with a Pattern Card, removing Knitter stitches every second row will form lacy knitting.

The sample is knitted with very thick yarn using the Pattern No.4 on page 95.

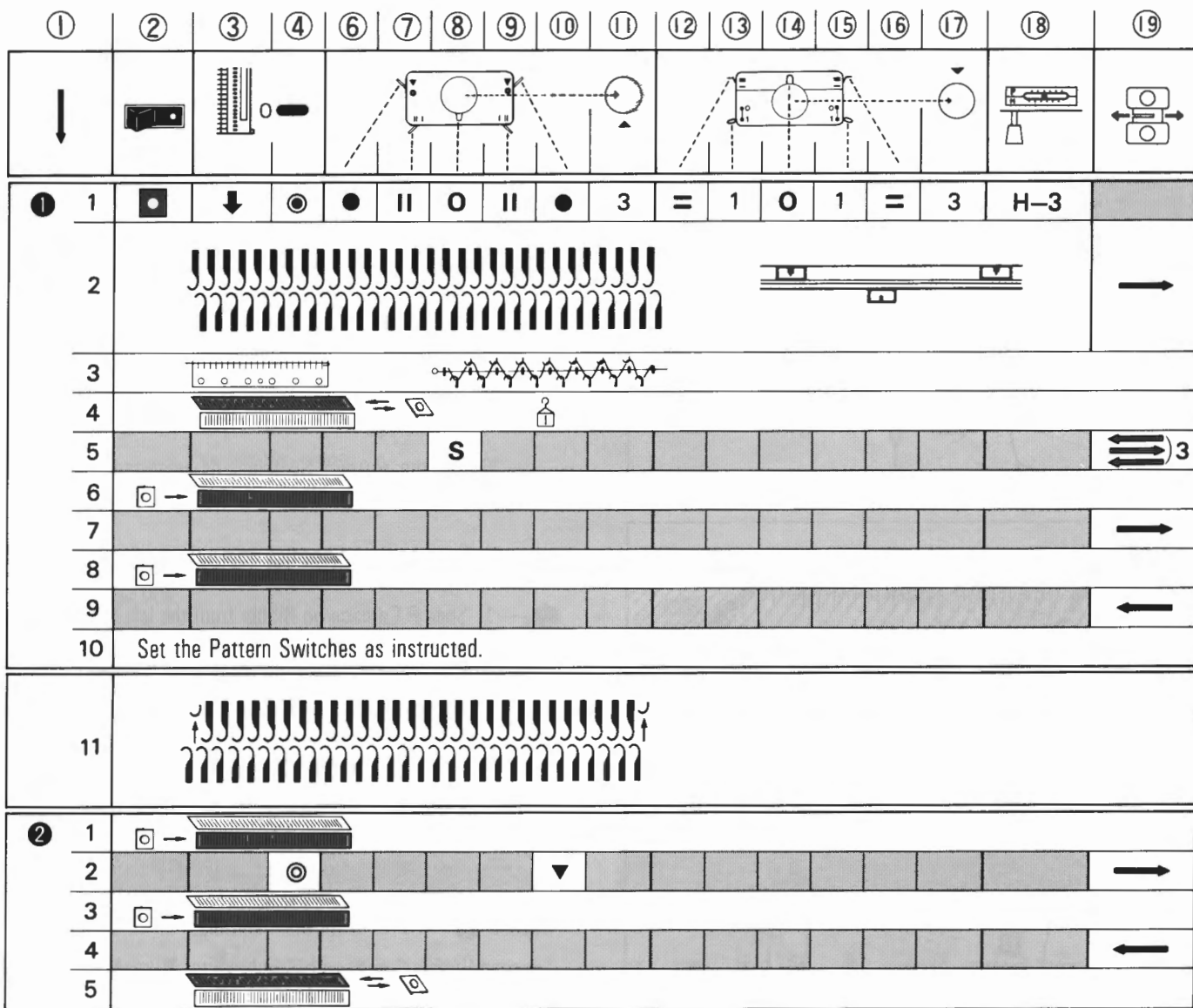

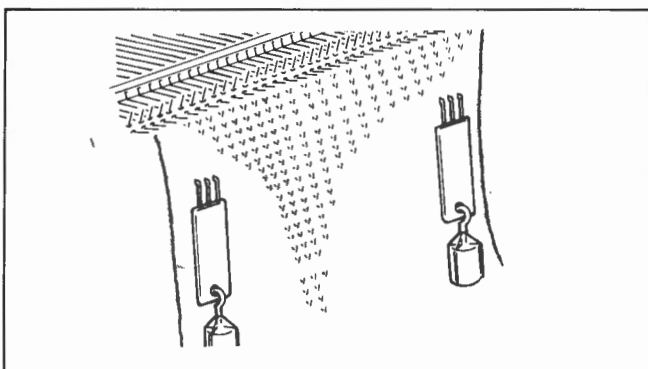
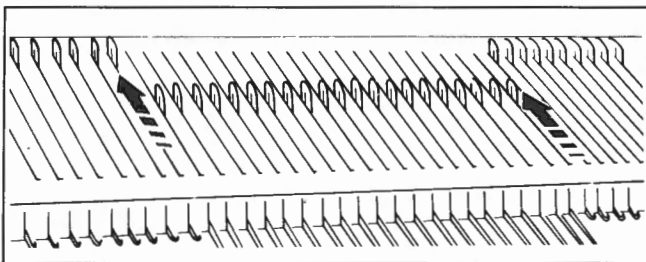
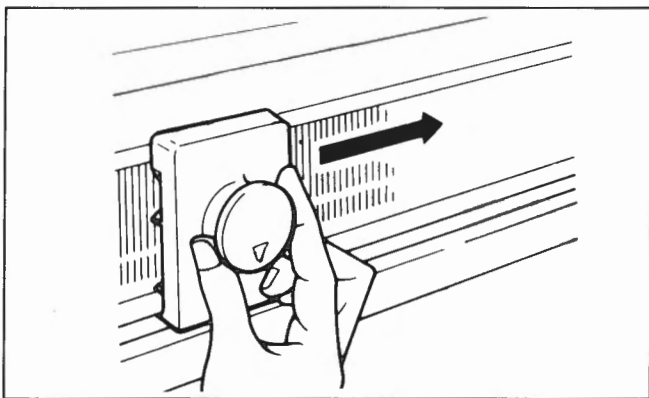
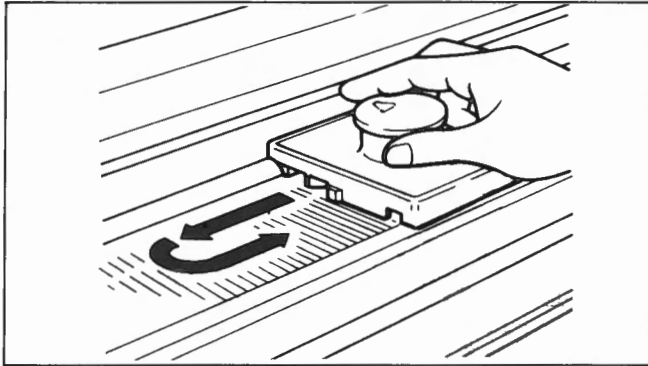
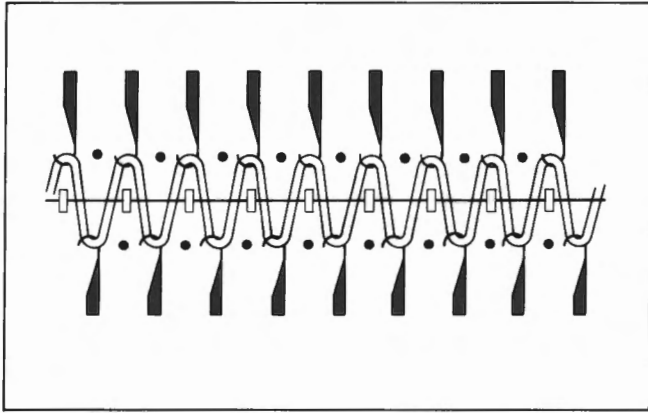

① — 1 Set machine controls as instructed.

Set Stitch Dials to the same as main knitting.

— 2 Arrange needles as instructed, set the Point Cams and Needle-1 Cam and knit from the left to the right with waste yarn.

— 3 When suspending Cast-on Comb (without Weights), insert it so that its teeth face Ribber Sinker Posts as illustrated.

If Cast-on Comb is suspended incorrectly, it will drop on the floor when Knitter stitches are removed.

— 4 Place P Carriage on the right side of Knitter Needle Bed.

Move P Carriage to the left and back again so that stitches are removed and the needles align in B position again.

— 5 Set Knitter Cam Lever to "S" and knit 3 rows with waste yarn.

— 6 Place P Carriage on the left side of Ribber Needle Bed, and slide it to the right to push up needles to C position.

— 7 Exchange waste yarn for main yarn in Yarn Feeder and knit from the left to the right.

— 8 Slide P Carriage on Ribber from the left to the right.

— 9 Knit from the right to the left.

— 10 Set the Pattern Switches as instructed below the picture on page 91.

— 11 Push both end needles on Knitter back to A position.

② — 1 Slide P Carriage on Ribber from the left to the right to push up needles to C position.

— 2 Press the Inspection Switch to turn off the light and set right Side Lever to ▼, then knit 1 row from the left to the right. (On Ribber, all the needles in C position knit, and on Knitter, only selected needles knit.)

— 3 Push up Ribber needles to C position using P Carriage.

— 4 Knit one row from the right to the left.

— 5 Remove stitches on Knitter using P Carriage.

Repeat ② — 1 ~ 5 for main knitting.

Suspend Hanger Combs with Weights after 10 rows and advance them every 10 rows upwards.

More samples for DRIVE LACE

Pattern No.1

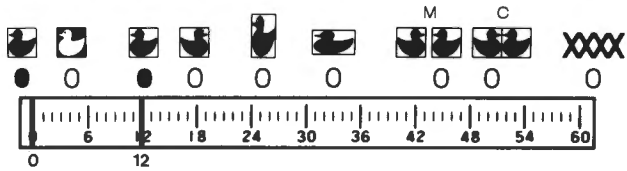
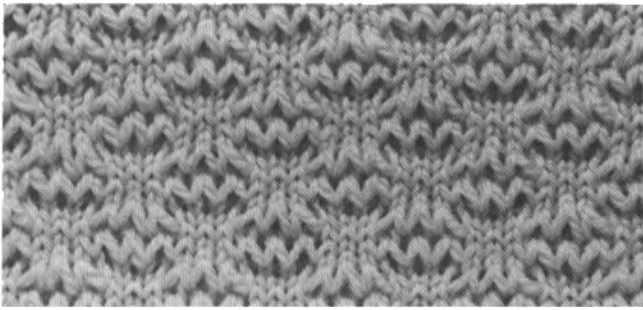

Pattern No.2

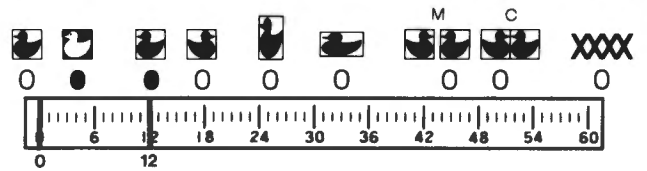
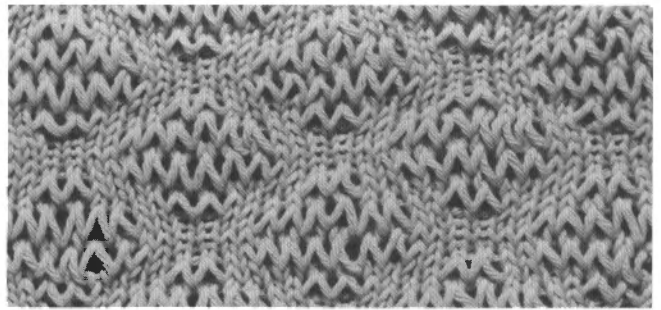

Pattern No.1

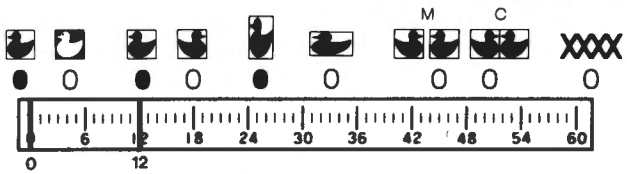
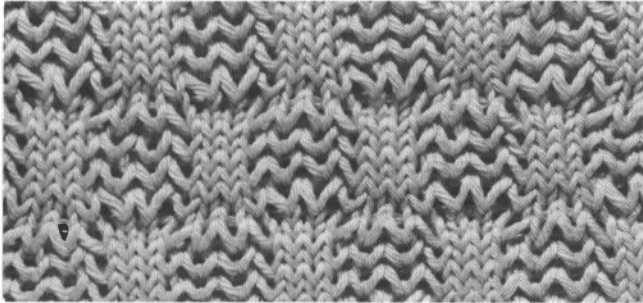

(Vertical Expansion)

Pattern No.5

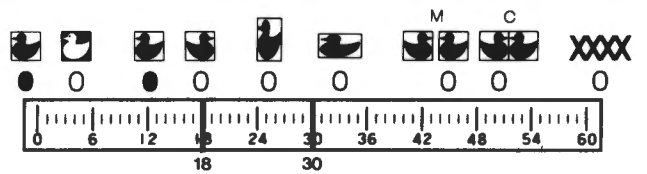
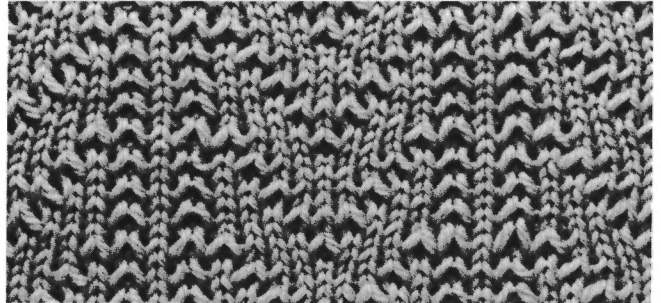

More samples for SLIP RIB.

(Refer to page 90)

Pattern No.2

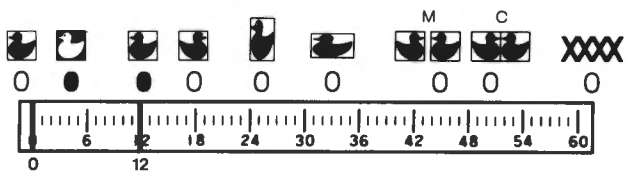
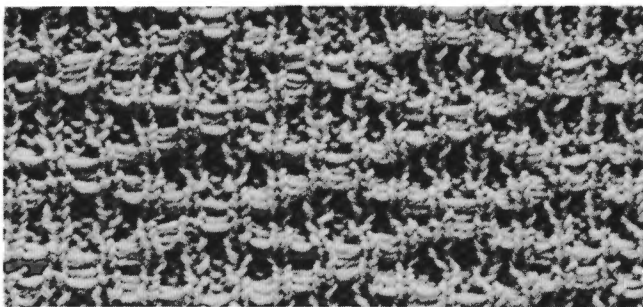

Pattern No.3

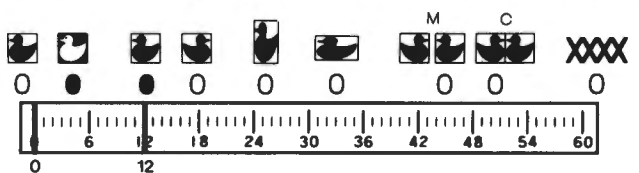
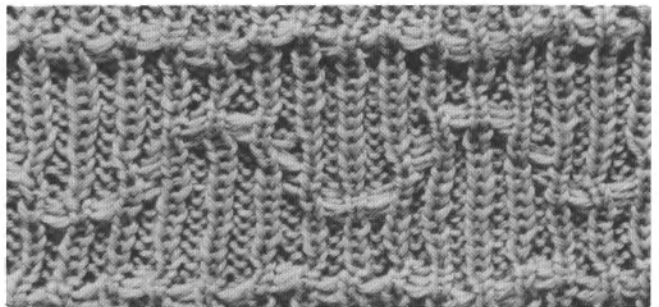

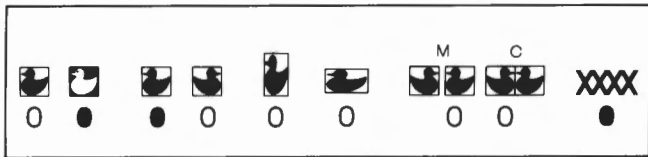

- 5 ~ 7 Changing the positions of the Cam Lever as instructed on the Operation Table, knit 3 rows.
- 8 Thread the contrast yarn "B" through the Auto Tension and place the end in the Yarn Clip. Press the Pattern Switch-6 to turn on the light as shown on the left. (Press this Switch just before knitting Double Jacquard.)

The right light of the Pattern switch-1 must be lit to knit the first row of the pattern.

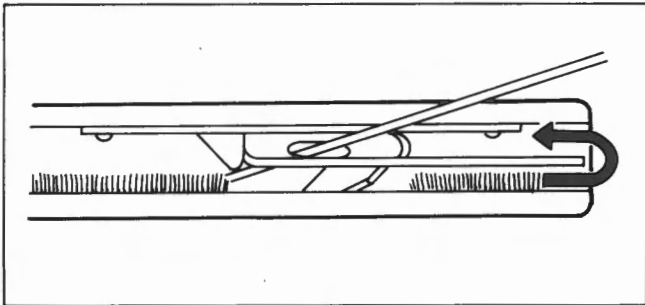

Main knitting

- ② — 1 Change machine controls to knit Double Jacquard. Start knitting from the right to the left with the main yarn "A".
- 2 ~ 3 Exchange the main yarn for the contrast yarn "B" and knit two rows.
- 4 Exchange the contrast yarn for the main yarn and knit.
- 5 Repeat steps ② — 1 ~ 4, exchanging the yarns every two rows with the Carriage on the left side.

Two lights of the Pattern Switch-1 lights on alternately every two rows.

PATTERN CARD

The following patterns are the same as the ones of Punch Cards supplied with the Ribber. Copy them onto your Design Card and use them.

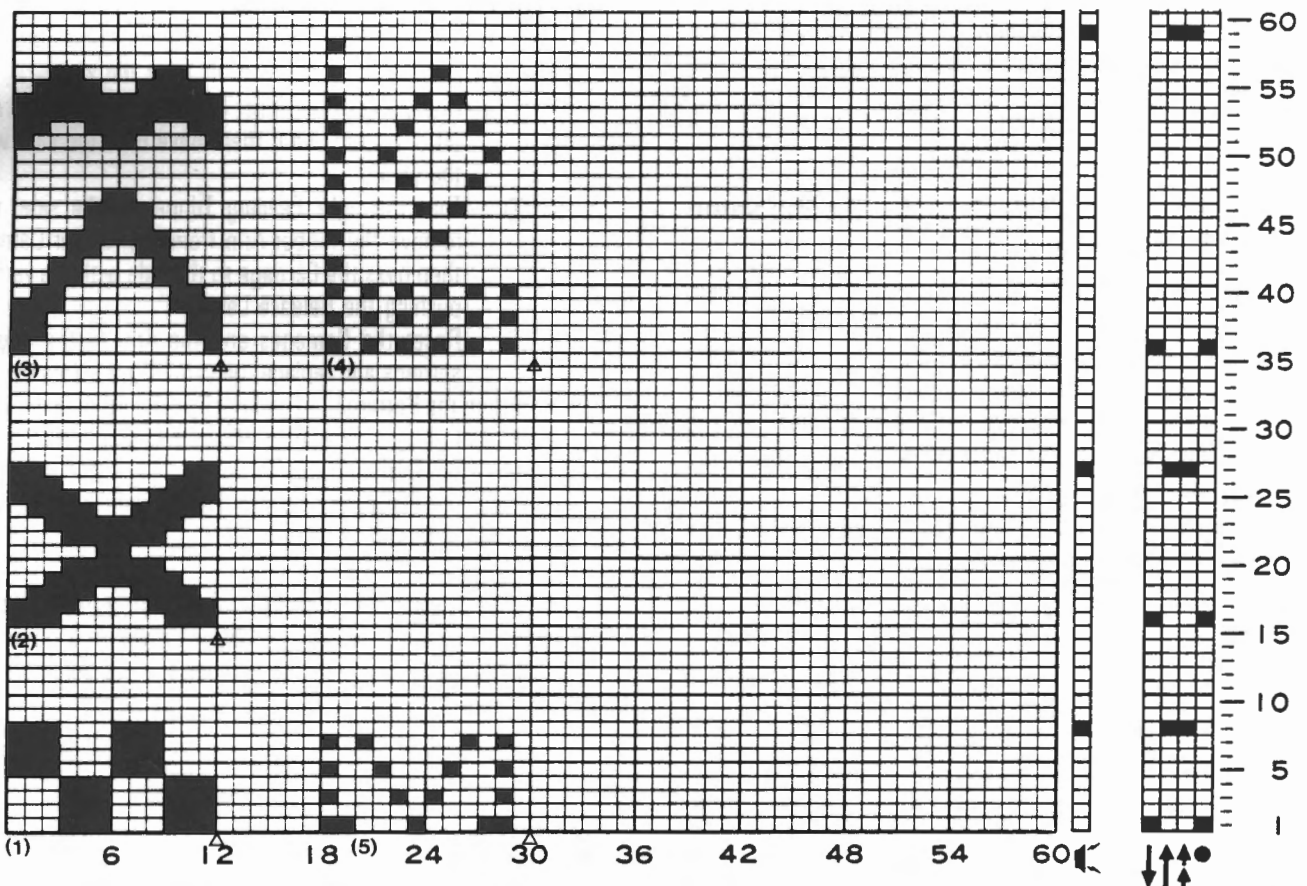

HELPFULL HINTS TO KNIT RIB STITCHES USING PATTERN CARDS

To change the pattern controls or the other settings of the machine while knitting

To change the pattern width or the Pattern Cards.

- 1— Press the Inspection Switch so the light comes on.
- 2— Reset the Pattern Width Indicator or exchange the Pattern Cards.
- 3— Press the Inspection Switch so the light goes off.
- 4— Start to knit.

To reset the Pattern Switches.

- 1— Press the selected Pattern Switch so its light comes on or goes off.
- 2— Start to knit.

To change the positions of the Needle-1 Cam and/or the Point Cams.

- 1— Press the Inspection Switch so the light comes on.
- 2— Replace the Needle-1 Cam and/or the Point Cams, and disconnect the Ribber Carriage from the Arm.
- 3— Move the Knitter Carriage twice without knitting by pushing the Release Lever.
- 4— Press the Inspection Switch so the light goes off.
- 5— Connect the Ribber Carriage and start to knit.

IMPORTANT

In case of knitting Double Jacquard;

Place the Carriage on the right side and follow the procedures above.

Press the Pattern Switch-6 just before knitting Double Jacquard and make sure that the right light of the Pattern Switch-1 is lit.

To knit Double Rib, which looks like the same as Double Jacquard

- 1— After the pattern in Double Jacquard has been completed, press the Inspection Switch so the light comes on.
- 2— Set the Pattern Card at the blank position of the Card.
- 3— Press the Inspection Switch to read the blank position.
- 4— Press the Inspection Switch so the light comes on and continue to knit in the same manner as for the ordinary Double Jacquard.

If you knit Double Jacquard in combination with Double Rib., the knitting effect is different.

If the Carriage has jammed...

- 1— Remove the yarn from the Yarn Feeder.
- 2— Disconnect the Ribber Carriage from the Arm and tilt it towards you, then move it to either end of the Needle Bed.
- 3— Remove the Ribber Arm from the Knitter Carriage, and move the Carriage in the direction it was going till it clears the working needles by pushing the Release Lever.
- 4— Check the stitches, and if the stitches have moved behind the latches, replace them into the hooks using the Transfer Tool.
- 5— Align the working needles in B position and unravel the incomplete row.
- 6— Press the Inspection Switch so the light comes on.
- 7— Turn the right Feeding Tripper to the side and pass the Carriage to the side with the yarn by pushing the Release Lever.
- 8— Reset the Carriages and the Arm to the original settings and replace the yarn into the Yarn Feeder.
- 9— Return the Pattern Card and the Row Counter by 1 row. (If the Knit Contour is in use, return the Pattern Paper, too.)
- 10— Press the Inspection Switch so the light goes off and continue to knit.

If incorrectly knitted...

- 1— Have the Carriage clear of the working needles and remove the yarn from the Yarn Feeder.
- 2— Unravel the incorrectly knitted rows.
- 3— Press the Inspection Switch so the light comes on.
- 4— If the Carriage is on the side opposite the yarn;
 - ①— Disconnect the Ribber Carriage from the Arm and tilt it towards you, then move it to the side with the yarn.
 - ②— Turn the right Feeding Tripper to the side, and remove the Ribber Arm from the Knitter Carriage then pass the Carriage to the side with the yarn by pushing the Release Lever.
 - ③— Reset the Carriages and the Arm to the original settings and replace the yarn into the Yarn Feeder.
- 5— Return the Pattern Card and the Row Counter by the same number of rows unravelled. (If the Knit Contour is in use, return the Pattern Paper.)
- 6— Press the Inspection Switch so the light goes off and continue to knit.

* In case of using the Pattern Switch-3 or knitting Double Jacquard, unravel an even number of rows. And return the Pattern Card by only half the number of rows unravelled.

