

Purchased 8-24-92

E 2193771 — AUTO KK98



***HOW TO USE  
YOUR KNITTING MACHINE***



## CONTENTS

ORIGINAL PATTERNS .....	1	WHAT TO DO IF YOU MAKE MISTAKES AS YOU KNIT	
PART NAMES .....	9	STOCKING STITCH AND PLATING .....	60
SETTING UP YOUR KNITTING MACHINE .....	13	PATTERN KNITTING .....	63
REPLACING YOUR MACHINE INTO THE CARRYING CASE .....	15	LACE OR FINE LACE PATTERN .....	66
BEFORE STARTING TO KNIT .....	17	HOW TO MOVE THE K-CARRIAGE ACROSS THE NEEDLE BED WITHOUT KNITTING .....	68
Holding Cam Lever · Cam Button Release Lever · Cam Buttons · Weaving Pattern Levers · Change Knob · Tension Dial · Cast-on Comb · Needle Positions · Carriage Direction Indicator · Row Counter · L-Carriage · Claw Weights · End Needle Selection Mechanism of the K-Carriage · Non Selection Mechanism of the L-Carriage		HOW TO CHECK IF THE NEEDLES ARE SELECTED CORRECTLY .....	68
HOW TO OPERATE YOUR KNITTING MACHINE		CHECK FOLLOWING POINTS IF THE NEEDLES ARE NOT SELECTED CORRECTLY .....	68
STOCKING STITCH (Plain Knitting)		<b>MAKING GARMENTS</b>	
1. Threading the yarn .....	23	HOW TO USE THE TRANSFER TOOL .....	69
2. How to cast on with a finished edge .....	24	HOW TO USE THE LATCHET TOOL .....	69
3. Stocking stitch .....	26	Making Rib by Hand .....	69
4. How to remove your knitting from the machine .....	27	HOW TO INCREASE STITCHES .....	71
<b>PATTERN KNITTING</b>		HOW TO DECREASE STITCHES .....	73
PUNCH CARD AND THE PATTERN .....	28	PARTIAL KNITTING	
RELATIONSHIP BETWEEN THE PUNCH CARD AND THE NEEDLES .....	29	1. Plain Stocking Stitch and Pattern Knitting .....	75
HOW TO SET THE PUNCH CARD .....	30	2. Lace or Fine Lace Pattern Knitting .....	77
BASIC STEPS TO PATTERN KNITTING .....	31	HOW TO SHAPE A ROUND NECKLINE	
SKIP STITCH PATTERN .....	33	Stocking Stitch and Plating .....	79
MULTI COLOUR SKIP STITCH PATTERN .....	34	Pattern Knitting .....	80
TUCK STITCH PATTERN .....	35	Lace or Fine Lace Pattern .....	82
MULTI-COLOUR TUCK STITCH PATTERN .....	36	HOW TO CAST ON WITH A FINISHED EDGE (CLOSED EDGE CAST ON)	
WEAVING PATTERN .....	37	"E" wrap method .....	84
WOVEN MOTIF PATTERN .....	39	Using the Latchet Tool .....	85
FAIRISLE PATTERN .....	40	Using the Weaving Pattern Lever .....	87
FAIRISLE MOTIF PATTERN .....	42	Waste knitting (Casting-on) .....	88
DOUBLE LENGTH PATTERN .....	46	BACK STITCH CASTING OFF (BINDING OFF) ...	89
LACE PATTERN AND FINE LACE PATTERN .....	47	CHAIN STITCH CAST OFF (BINDING OFF) .....	90
LACE AND FINE LACE MIXED .....	50	WASTE KNITTING (CAST OFF) .....	92
ISOLATED LACE PATTERN .....	51	CORD KNITTING .....	92
PLATING .....	53	CABLE STITCH PATTERN .....	93
CHANGING THE MAIN YARN AND THE PLATING YARN .....	55	HOW TO MAKE A HEM	
PLATED TUCK STITCH PATTERN .....	56	Plain Hem .....	94
MAKING YOUR ORIGINAL PATTERN .....	57	Picot Hem .....	95
<b>USEFUL HINTS</b> (PROBLEMS DURING KNITTING)		1 x 1 Elastic Hem .....	97
WHAT TO DO WHEN YOU CANNOT KNIT SMOOTHLY		HOW TO MAKE A BUTTONHOLE .....	98
1. When the needles don't catch the yarn properly .....	58	USING A SEWING MACHINE FOR MAKE-UP ...	99
2. When the K-Carriage is hard to push back and forth .....	58	SEAMING .....	100
3. When stitches are not formed correctly .....	58	PREPARING YOUR YARN .....	101
4. How to pick up a dropped stitch .....	59	<b>REPLACING A NEEDLE</b> .....	102
		<b>CLEANING AND MAINTENANCE</b> .....	103
		<b>LIST OF PATTERN VARIATION</b> .....	104



# ORIGINAL PATTERNS

## SKIP STITCH PATTERN

Refer to P.33.

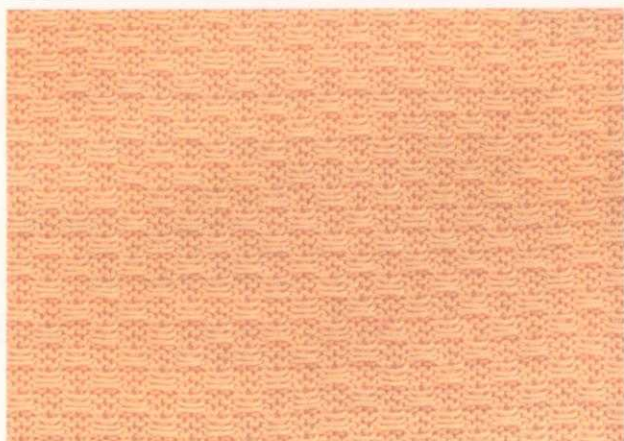

Card No. 2

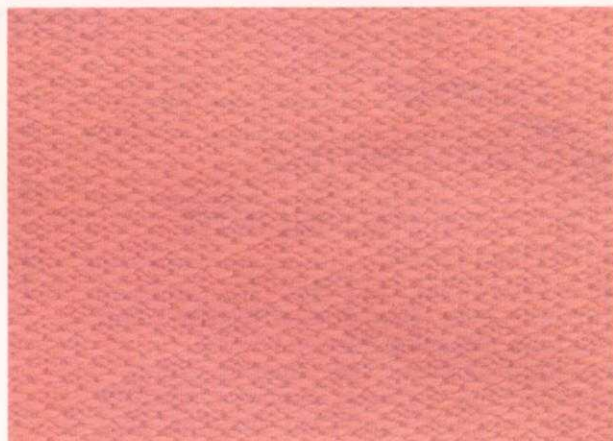

Card No. 3

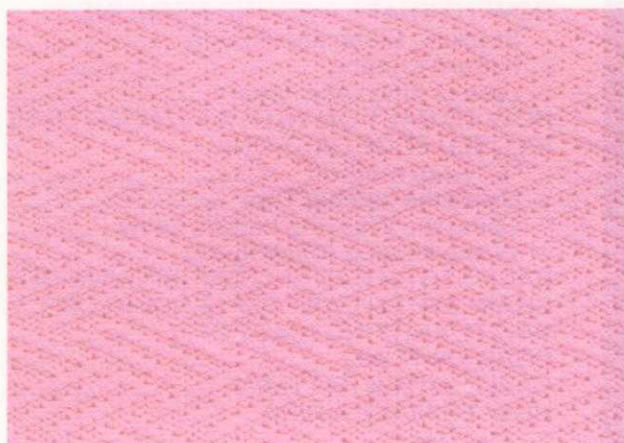

Card No. 5



Card No. 11

## MULTI-COLOUR SKIP STITCH PATTERN

Refer to P.34.

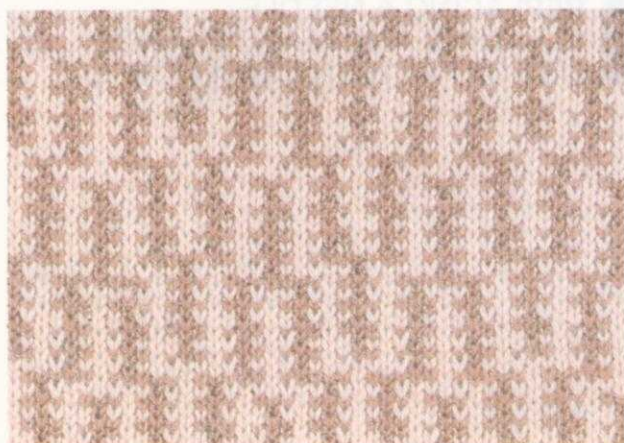

Card No. 5

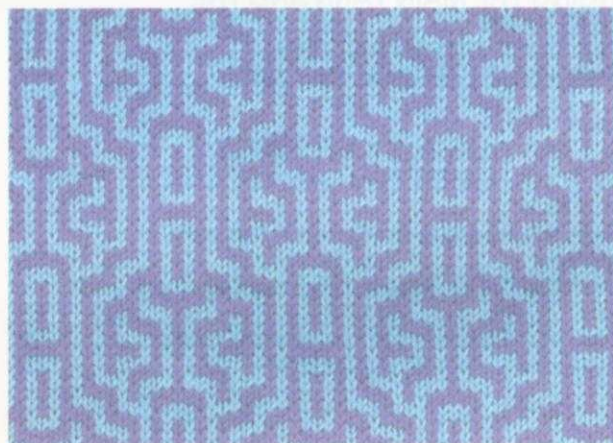

Card No. 7



**TUCK STITCH PATTERN**

Refer to P.35.

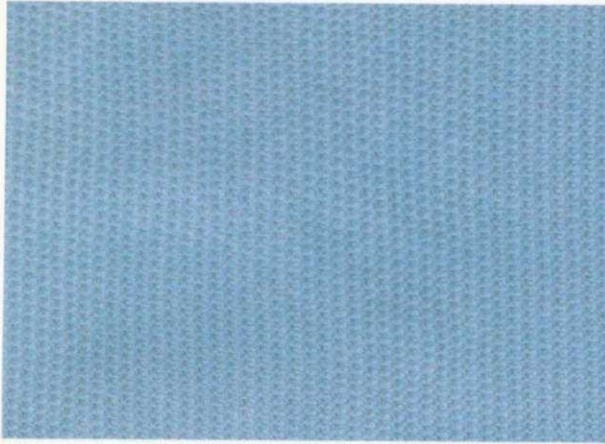

Card No. 1

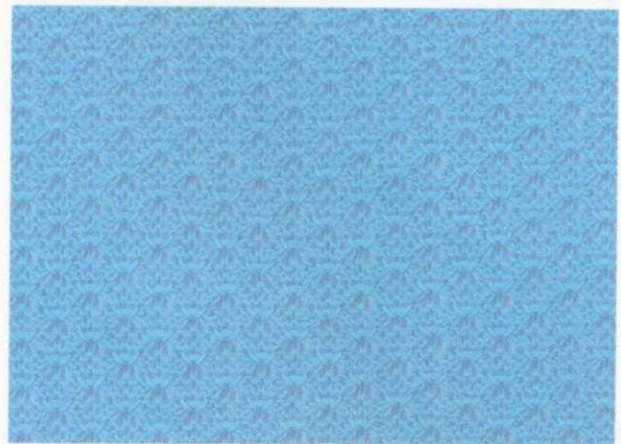

Card No. 2

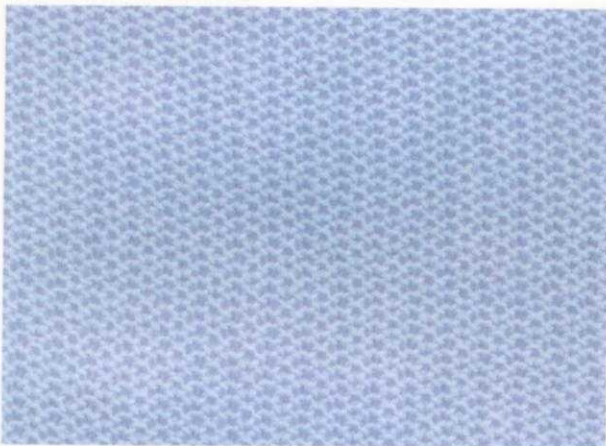

Card No. 3

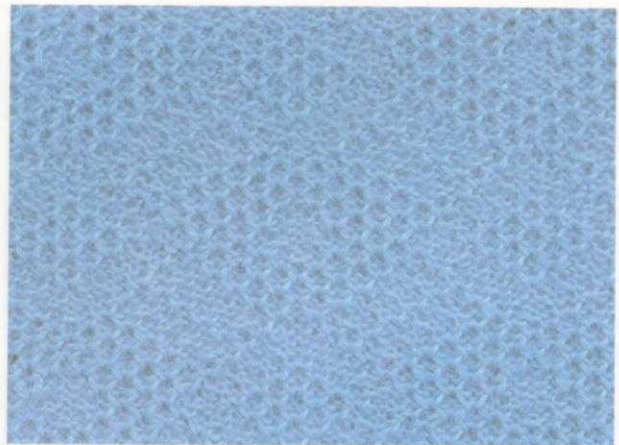

Card No. 7

**MULTI-COLOUR TUCK STITCH PATTERN**

Refer to P.36.



Card No. 2

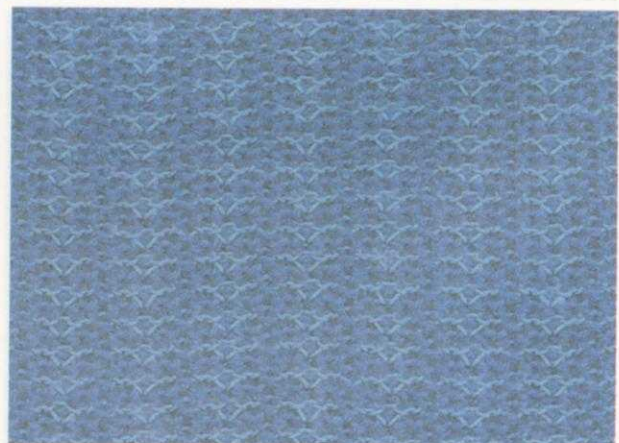

Card No. 3



FAIRISLE PATTERN

Refer to P.40.

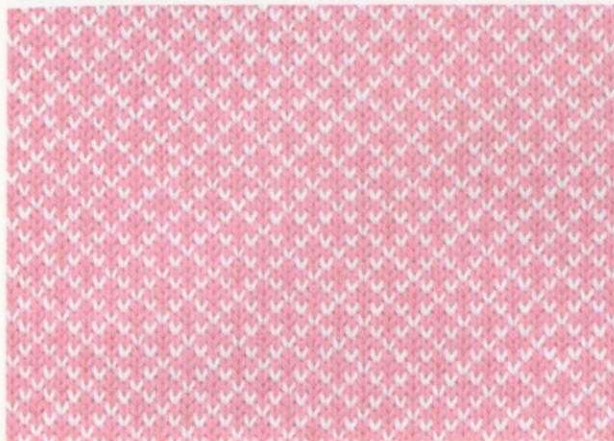

Card No. 3



Card No. 4



Card No. 5



Card No. 6

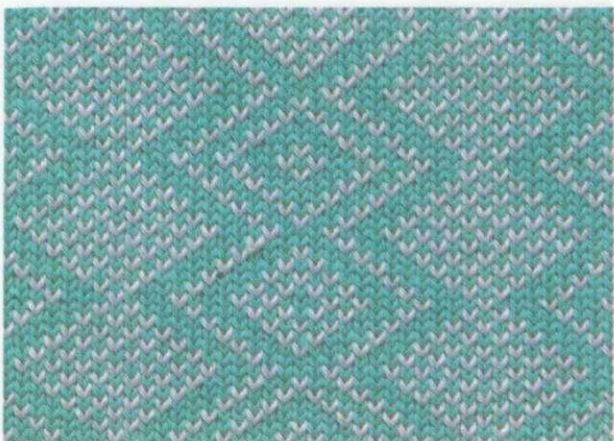

Card No. 8

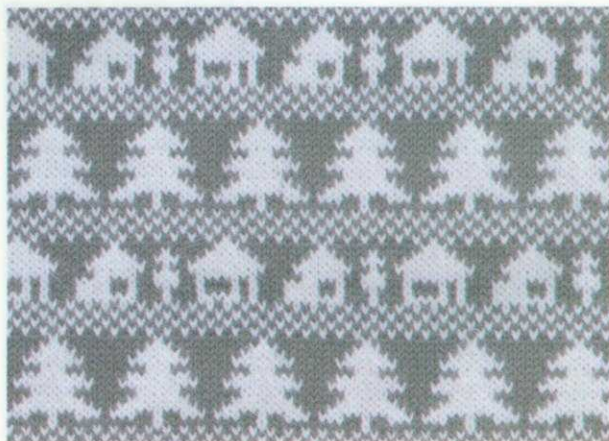

Card No. 9





Card No. 10



Card No. 12



Card No. 14



Card No. 15



Card No. 16

**FAIRISLE MOTIF PATTERN** Refer to P.42.



Card No. 13



**WEAVING PATTERN**

Refer to P.37.



Card No. 1

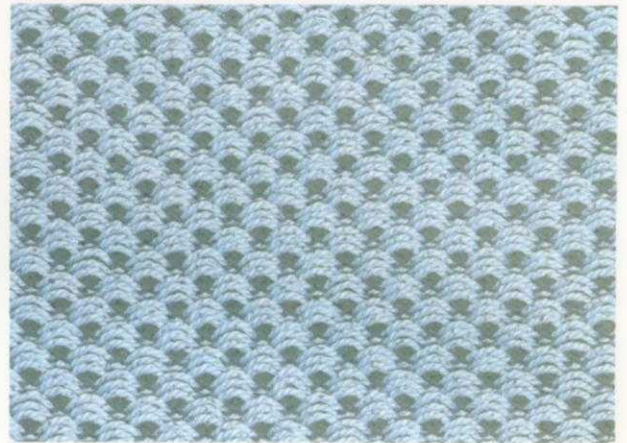

Card No. 2



Card No. 5

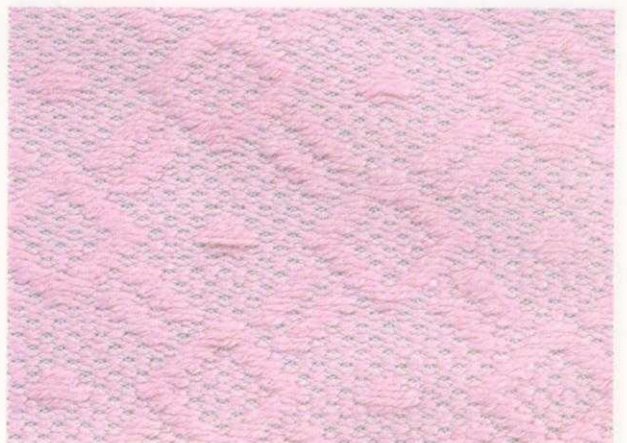

Card No. 7

**WOVEN MOTIF PATTERN**

Refer to P.39.

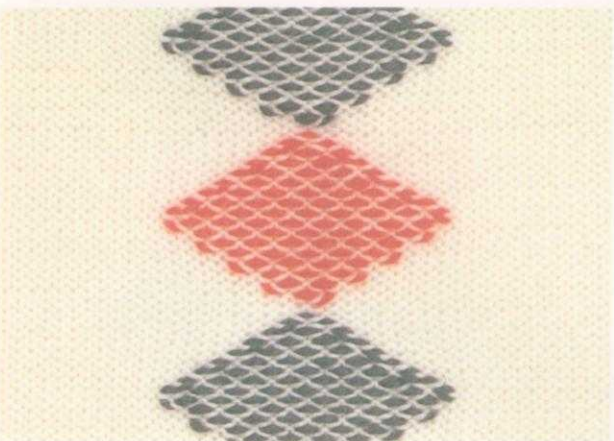

Card No. 1





**PLATED STITCH PATTERN**

Refer to P.53, 55.



FRONT

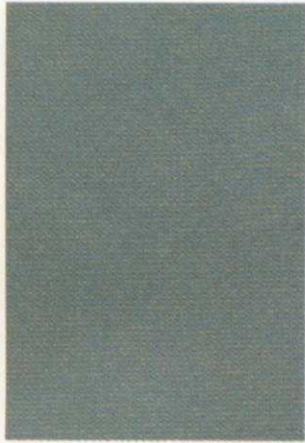

BACK



FRONT

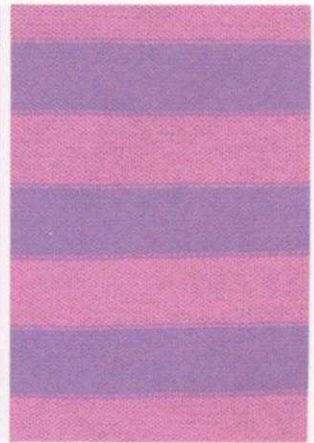

BACK

**PLATED TUCK STITCH PATTERN**

Refer to P.59.

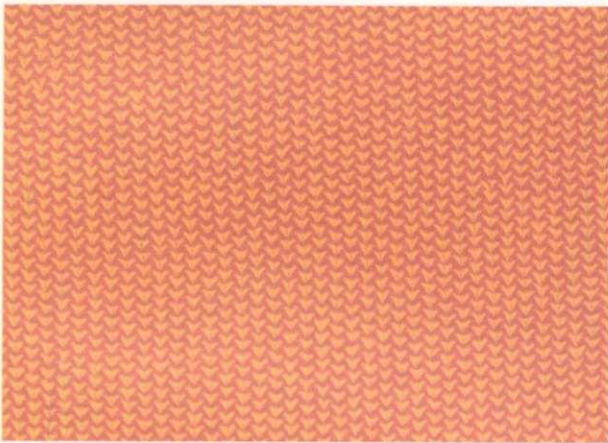

Card No. 1  
BACK

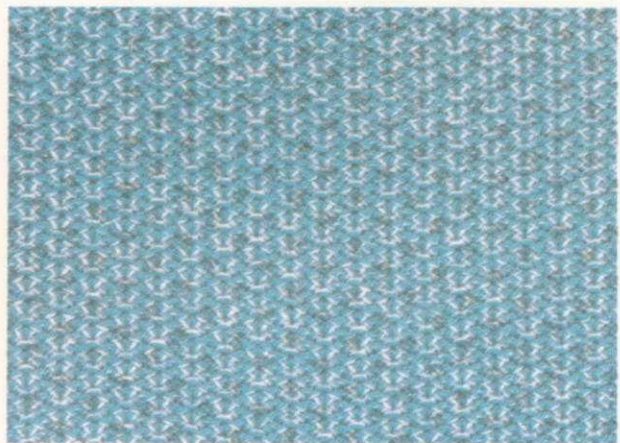

Card No. 3  
BACK



Card No. 8  
BACK





LACE PATTERN

Refer to P.47.

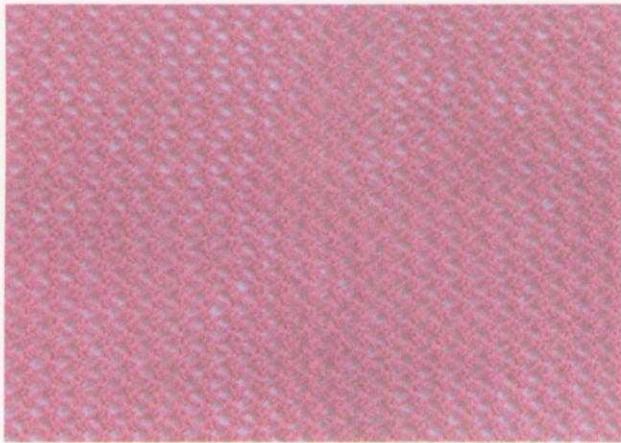

Card No. 17

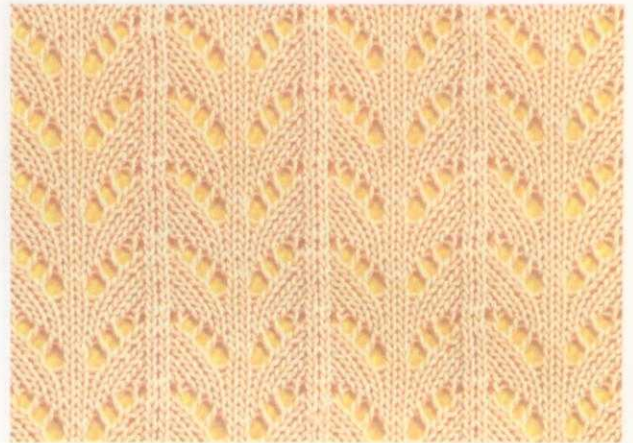

Card No. 18

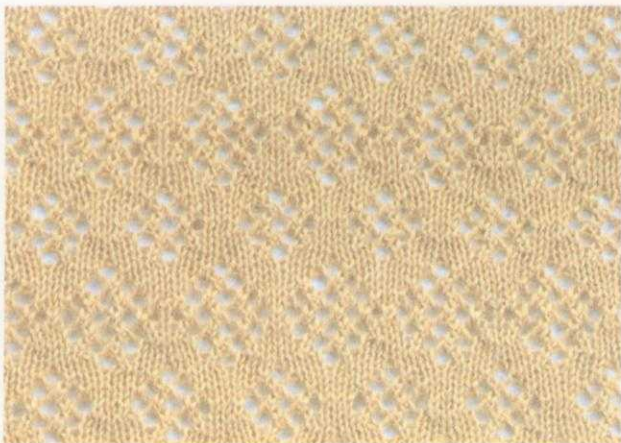

Card No. 19



Card No. 20

ISOLATED LACE PATTERNS

Refer to P.51.

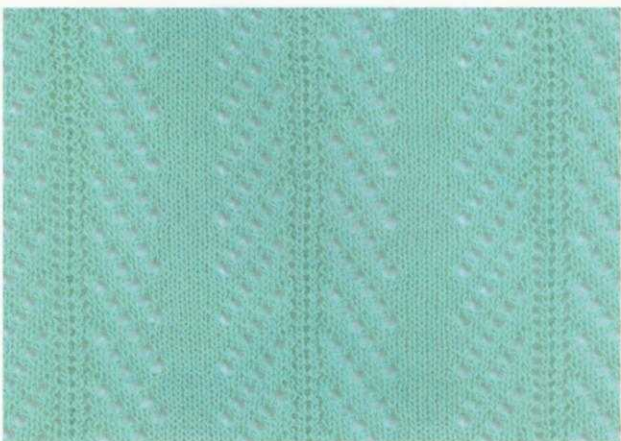

Card No. 20  
<Using L-Point Cam (4-needle)>



Card No. 20  
<Using L-Point Cam (8-needle)>



**FINE-LACE PATTERN** Refer to P.47.

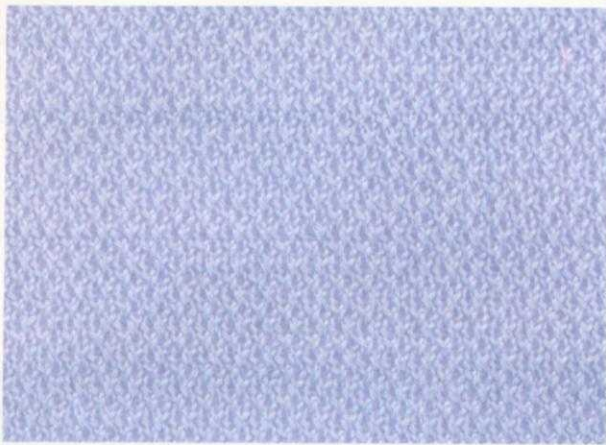

Card No. 17

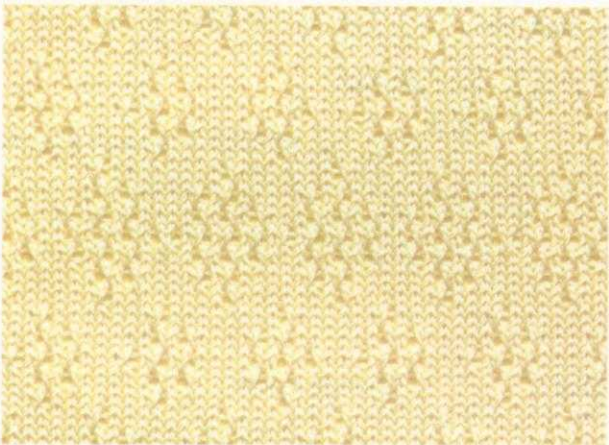

Card No. 19

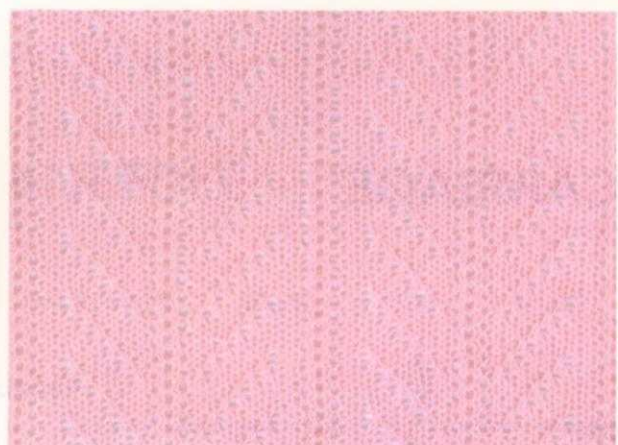

Card No. 20

**LACE AND FINE-LACE PATTERN MIXED** Refer to P.50.



Card No. 19  
→ N (Normal Lace)  
→ F (Fine Lace)



Card No. 19  
→ F (Fine Lace)  
→ N (Normal Lace)

# PART NAMES

## ●MACHINE

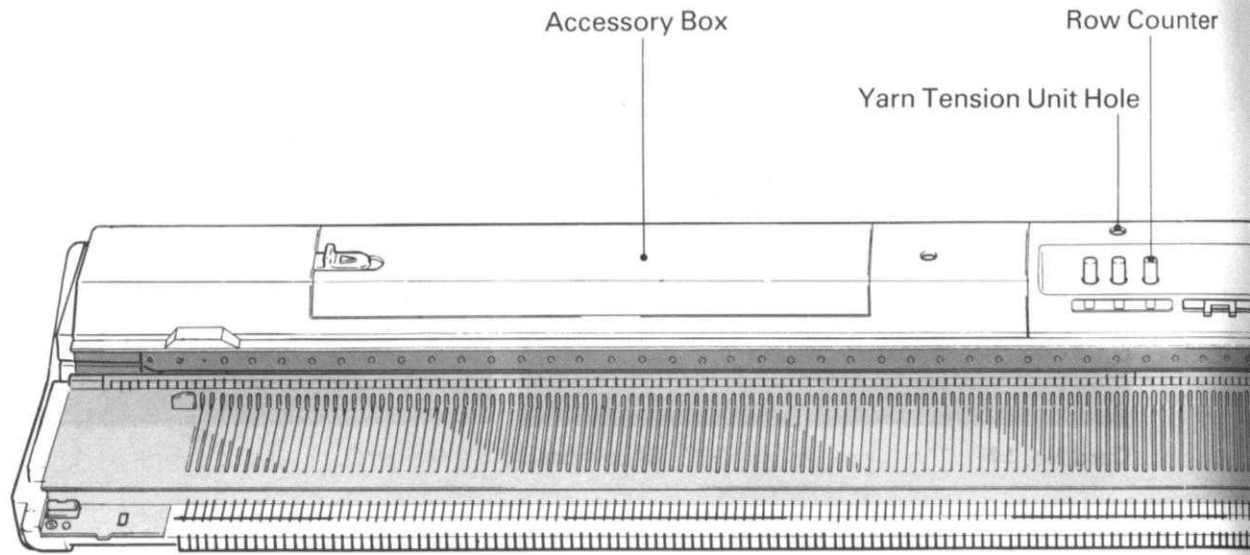

## ●K-CARRIAGE

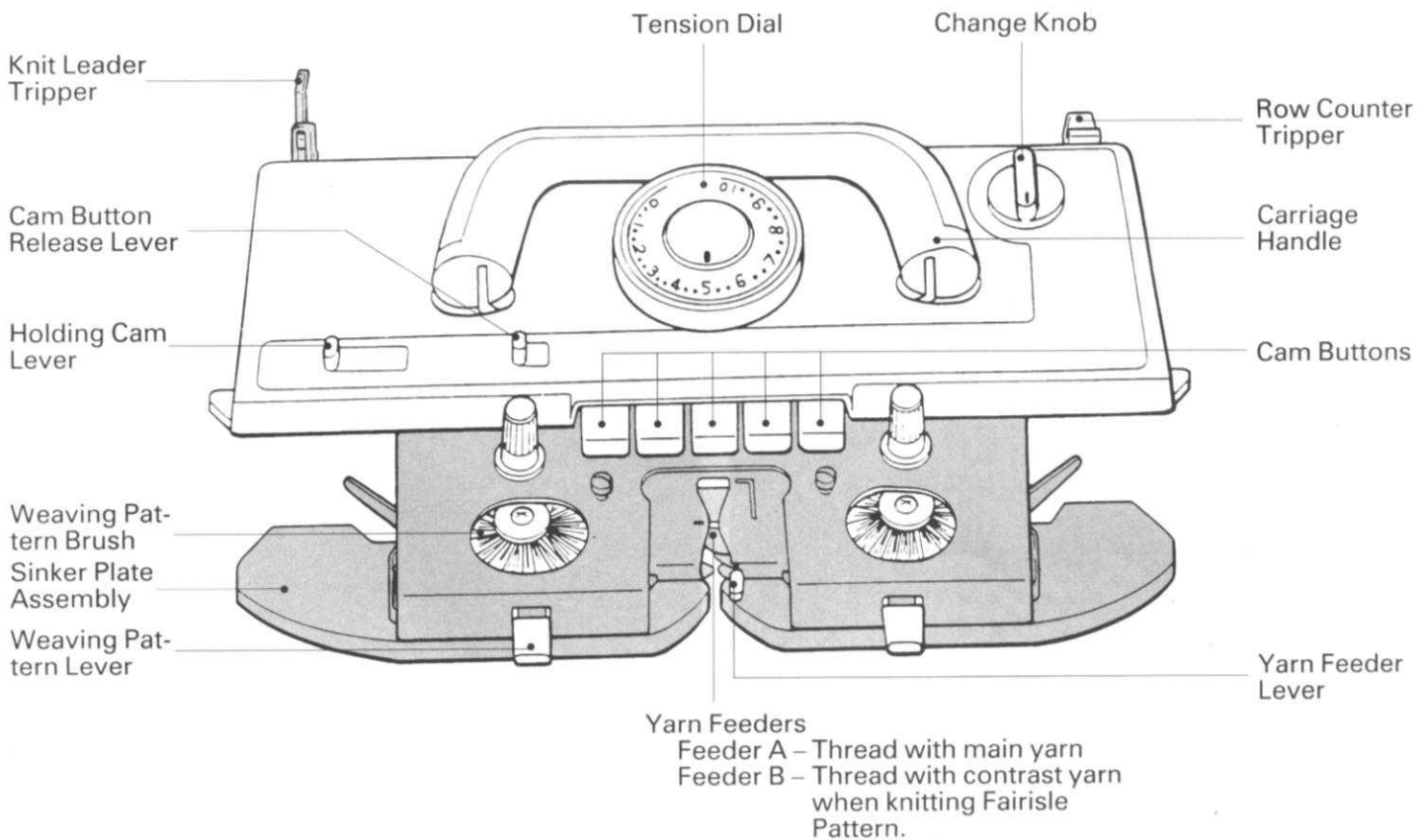



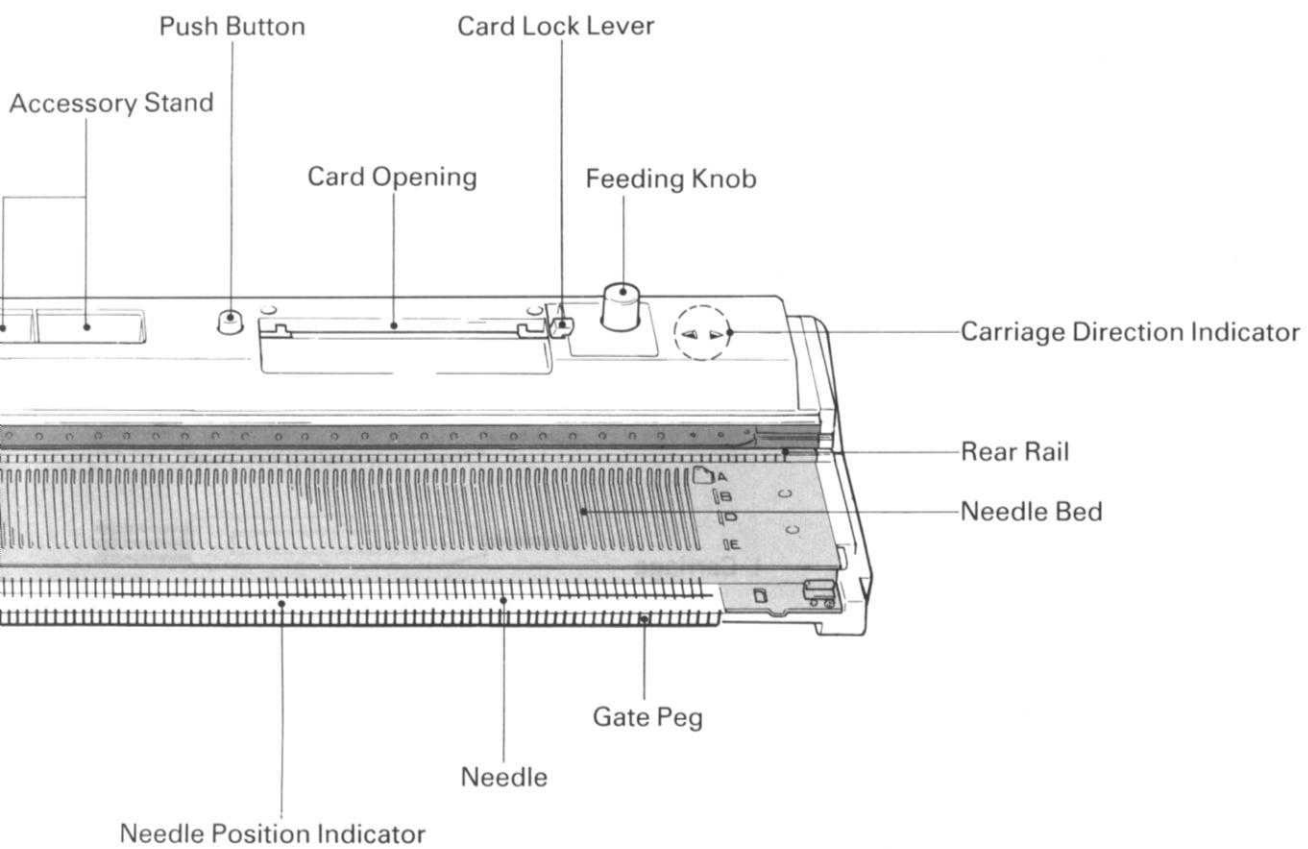

## ● NEEDLE

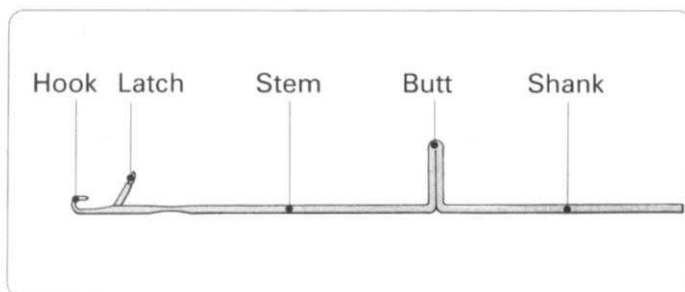

## ● CASE

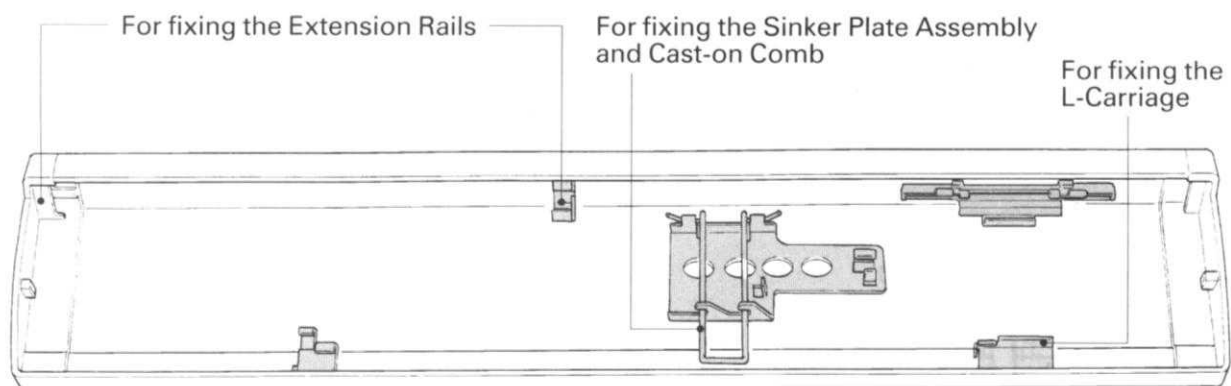



# ● ACCESSORIES

Yarn Tension Unit

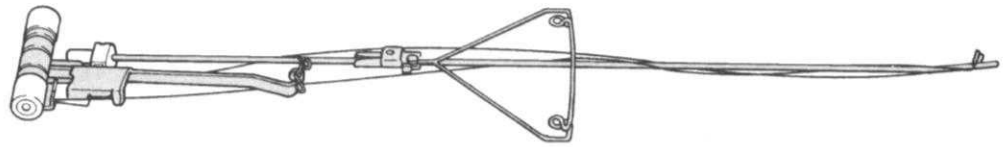

Cast-on Comb



Extension Rails

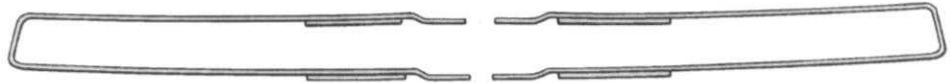

Punch Cards (20 pcs.)

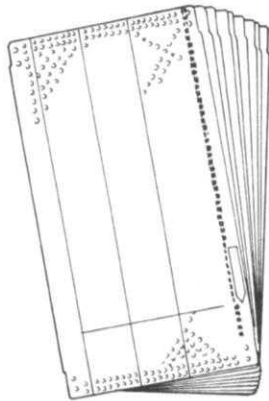

L-Carriage

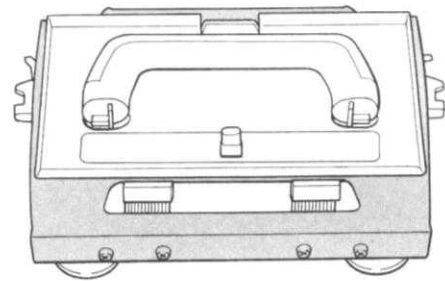

L-point Cam



for 4-needles  
(6 pcs.)

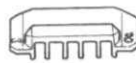

for 8-needles  
(6 pcs.)

Table Clamps (2 pcs.)



One-point Cam (1 pce.)



Motif Knitting Cam M (2 pcs.)

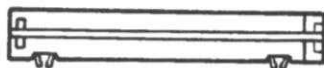

Motif Knitting Cam L & R (1 each)



Claw Weights (2 pcs.)

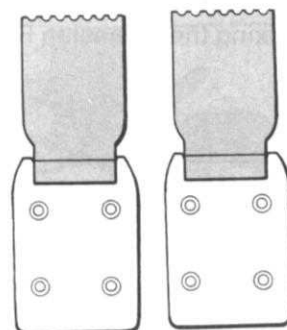



Crochet Hook



Latchet Tool



Transfer Tools  
(1 × 2, 1 × 3, 2 × 3)

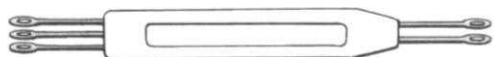
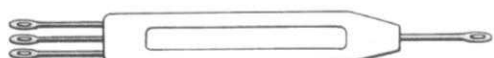
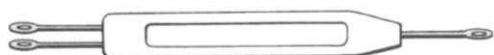

Needle Pusher

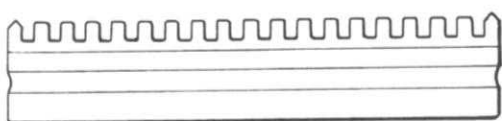

Cast-on Thread



Tapestry Needle



Spare Needles (3 pcs.)

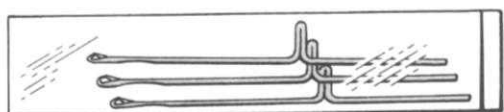

Plating Yarn Feeder

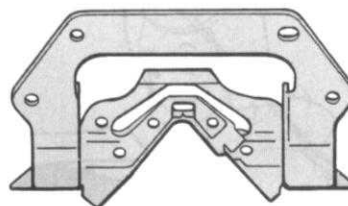

Hand Brush

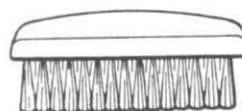

Yarn Wax



Plastic Punch Card Snaps (4 pcs.)

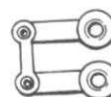

Oil



Carriage Lock



# SETTING UP YOUR KNITTING MACHINE

- ① Place the machine on a firm table, with the Carrying Case Handle away from you and unlock the catches. Lift up the case top and pull it towards you to release the lid.



- ② Open the Accessory Box.

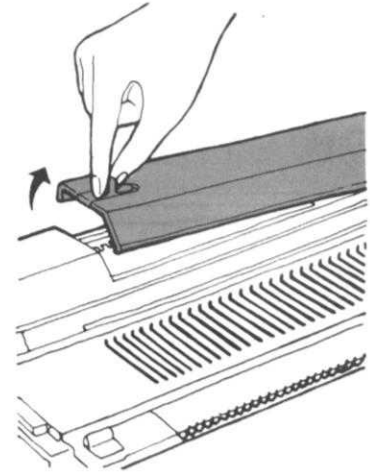

- ③ Take the two Table Clamps out of the Accessory Box.

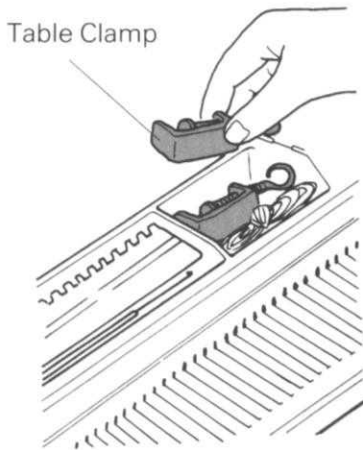

- ④ Fasten the machine to the table with the Table Clamps.

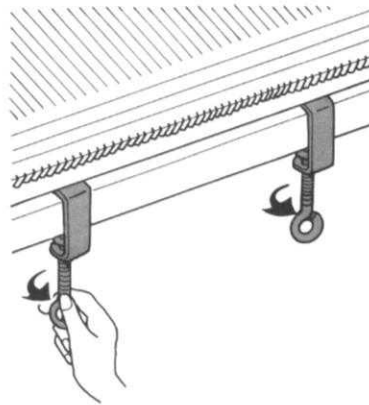

- ⑤ Loosen the knob and remove the Carriage Lock.

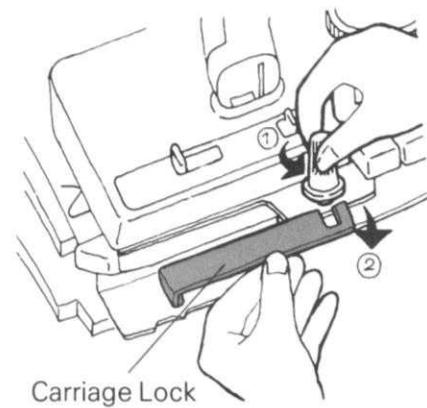

- ⑥ Release Spring and remove the Sinkers Plate Assembly from the lid of the Carrying Case.

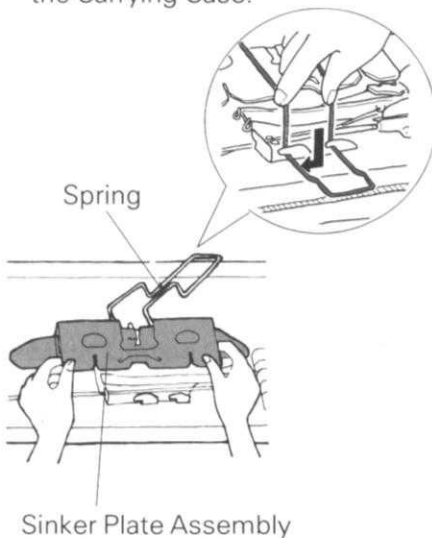

- ⑦ Screw the Sinker Plate Assembly onto the K-Carriage.

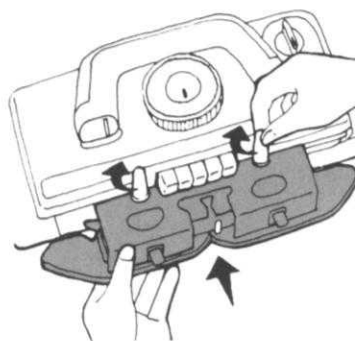

- ⑧ Raise the Carriage Handle by pulling it towards you.

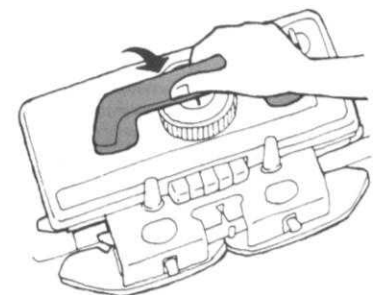



- 9 Take the Yarn Tension Unit out of the Carrying Case lid in the order ①, ②, ③, as shown.

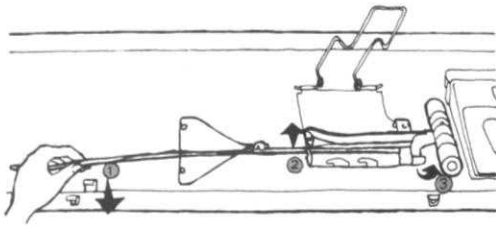

- 10 Unwind the Take-up Springs from the Rod.

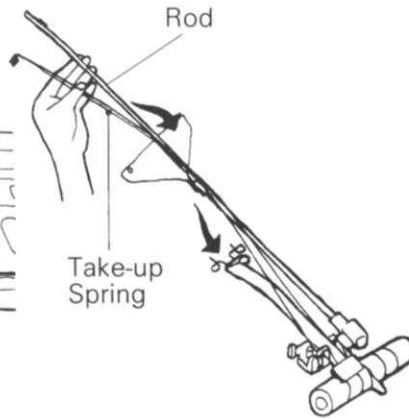

- 11 Lift the Front Guide Arm in the direction of the arrow as far as it will go.

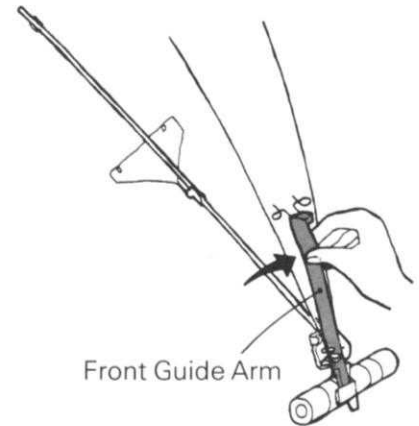

- 12 Turn back the Take-up Springs until you hear a "Click."

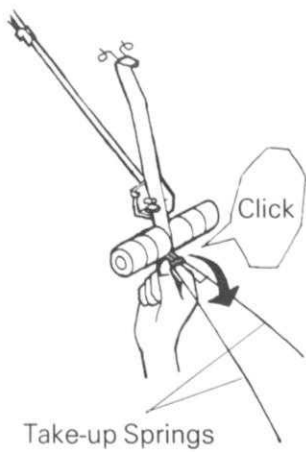

- 13 Raise the Rear Yarn Guide.

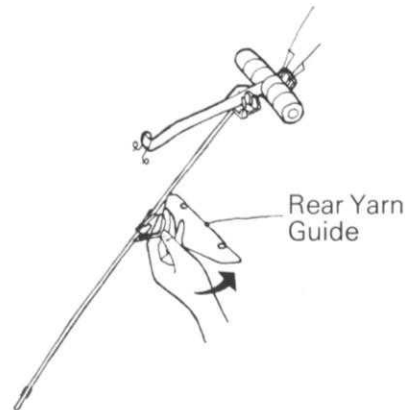

- 14 Insert the end of the Rod into the hole at the back of the machine.

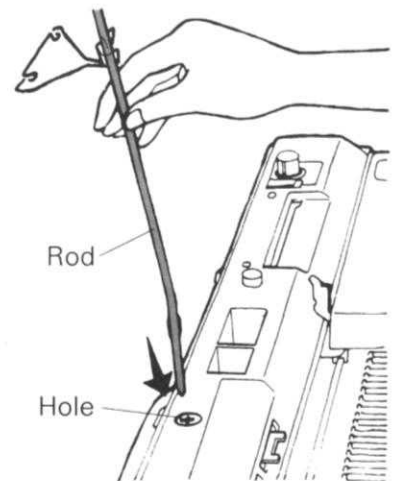

The machine is now set up.

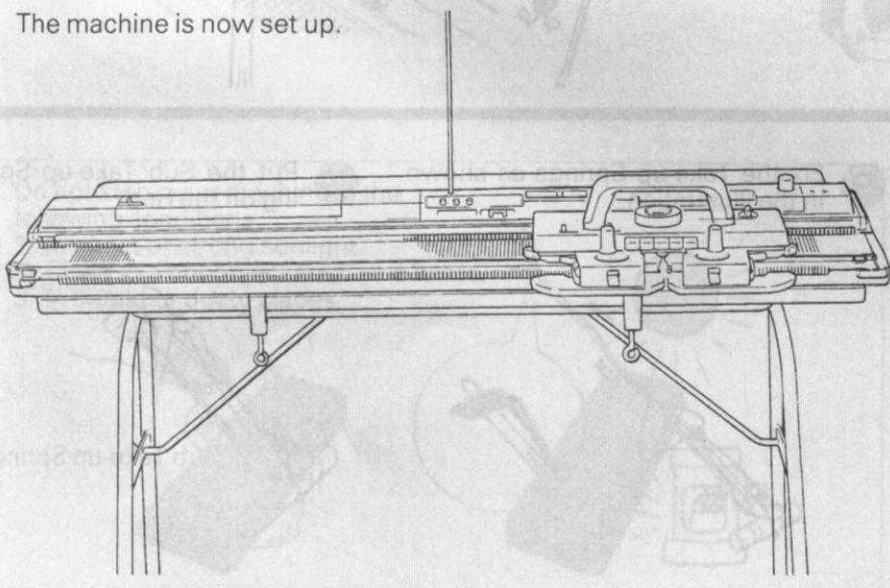

# REPLACING YOUR MACHINE INTO THE CARRYING CASE

This is how your machine should look when it is packed away.

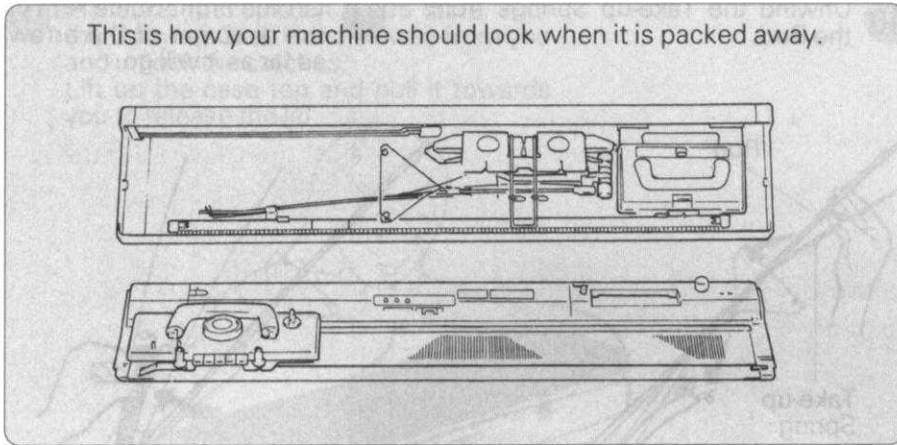

- 1 Fold down the handle on the L-Carriage. Push the Release Button and replace the L-Carriage in the Carrying Case.

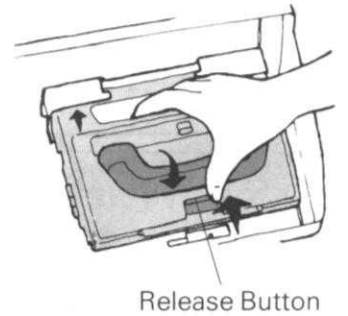

- 2 Join the two sections of the Cast-on Comb.

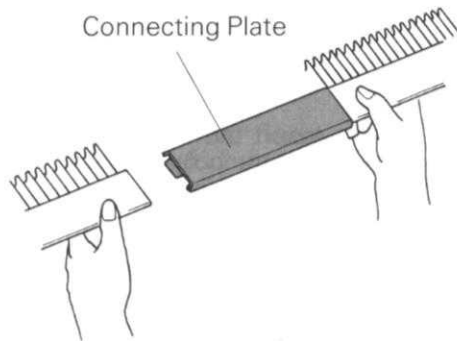

- 3 Lift the Spring and replace the Cast-on Comb back into the Lid.

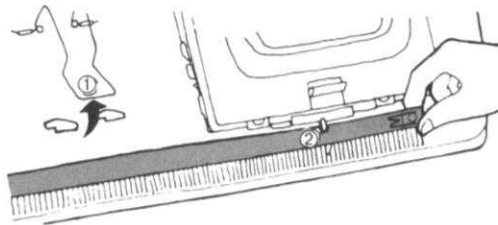

- 4 To remove the Extension Rails, lift up and pull.

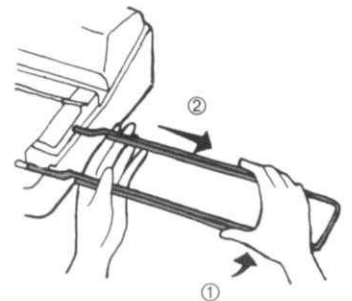

- 5 Put the Extension Rails in the Carrying Case.

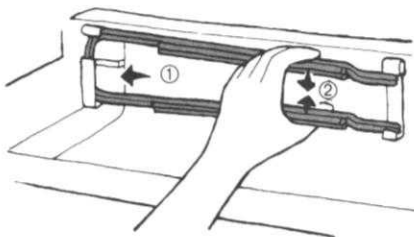

- 6 Remove Yarn Tension Unit and fold down the Front Guide Arm.

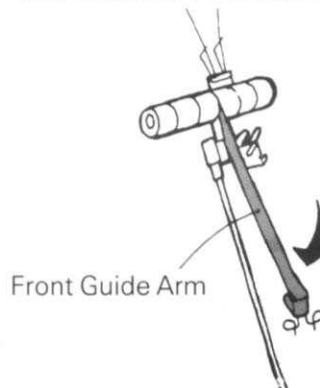

- 7 Wind the Take-up Springs.

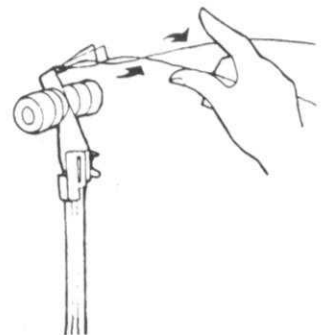

- 8 Next fold down the Take-up Springs.

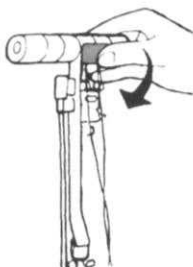

- 9 Fix the Take-up Springs as shown in the illustration.

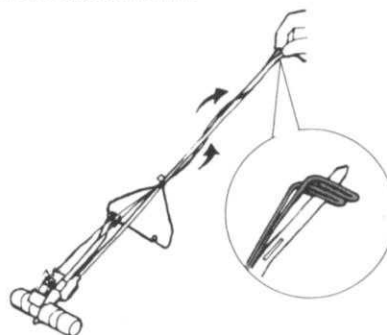

- 10 Put the Sub Take-up Spring on the Rod.





- 11 Fold down Rear Yarn Guide.

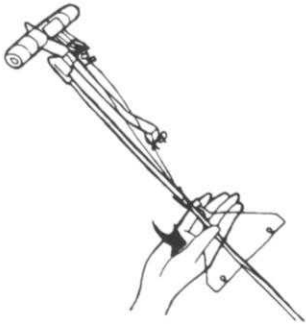

- 12 Replace the Yarn Tension Unit into the Case in the order ①, ②, ③ as shown.

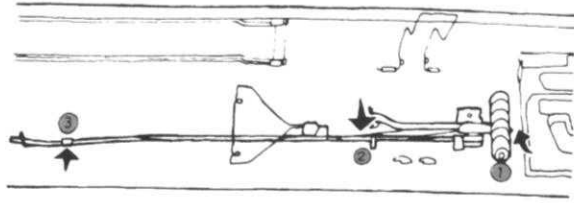

- 13 Loosen knobs and remove the Sinker Plate Assembly from the K-Carriage.

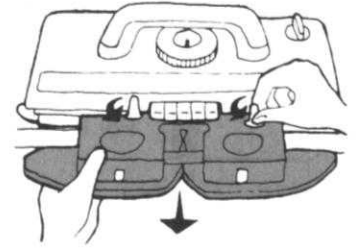

- 14 Put the Sinker Plate Assembly in the Case where indicated and secure it with the Spring.

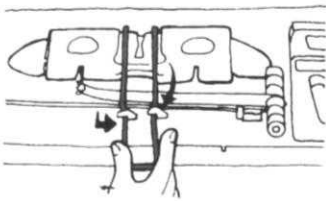

- 15 Push all Needles back to A Position and fold down Handle on K-Carriage. Insert the Carriage Lock into the hole in the left side of the machine and secure the K-Carriage as illustrated.

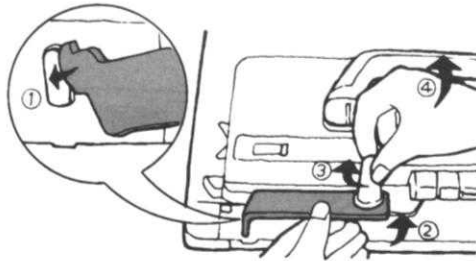

- 16 Unscrew the Table Clamps and put them in the Accessory Box with the other parts.

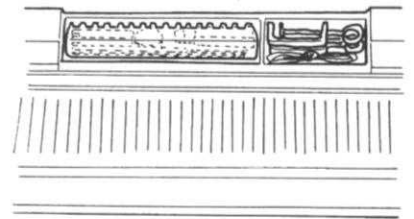

- 17 Then close the lid of the Accessory Box.

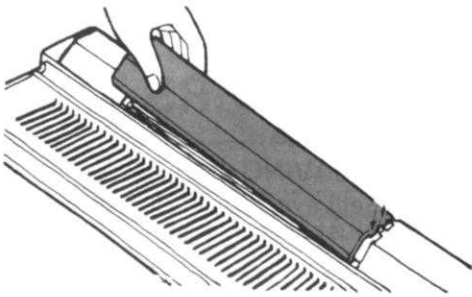

- 18 Hold the lid and replace it as shown. When it is in place, lock the two catches on either side of the Handle.

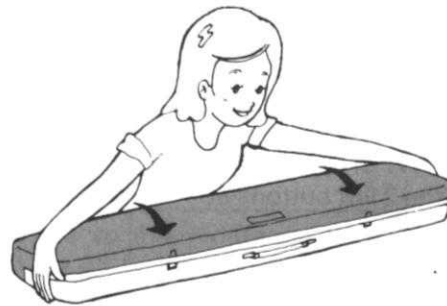

Do not store your machine in the following conditions.

1. In direct or strong sunlight.
2. Close to a hot object such as a heater.
3. In humid or dusty places.



# BEFORE STARTING TO KNIT

## HOLDING CAM LEVER

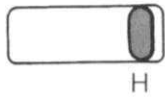

For Partial Knitting

H

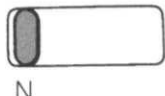

Except Partial Knitting

N

## CAM BUTTON RELEASE LEVER

Release the Cam Buttons by sliding the Cam Button Release Lever to the right.

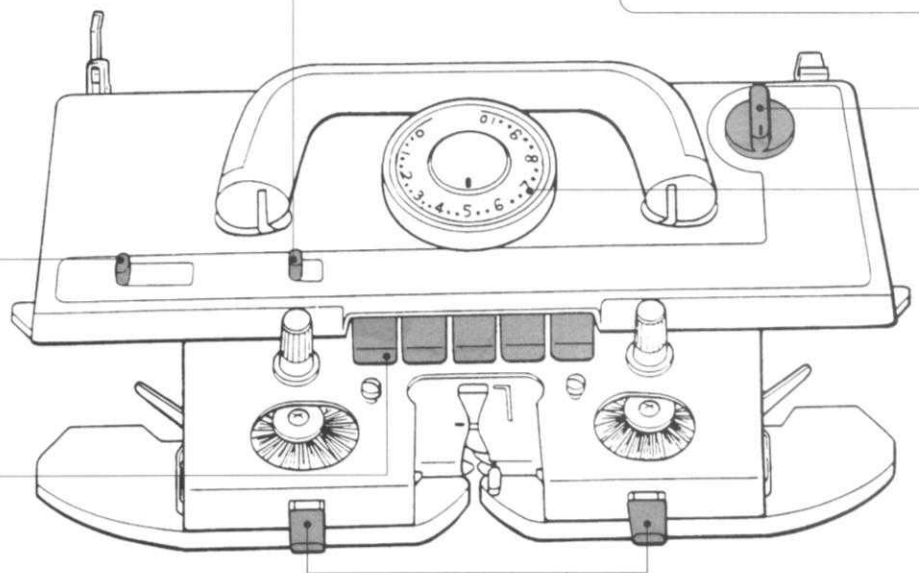
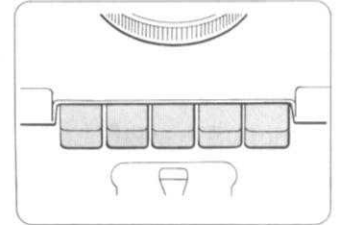
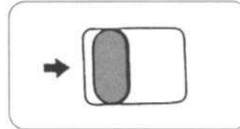

## CAM BUTTONS

Use the Cam Buttons according to the pattern you want.

## WEAVING PATTERN LEVERS

**TUCK STITCH PATTERN**  
Push in the 2 left buttons at the same time.

**FAIRISLE PATTERN**  
Push the middle button.

**WEAVING PATTERN**  
Set Levers to W.T Weaving Brushes in use.

**SKIP STITCH PATTERN**  
Push in the 2 right buttons at the same time.

**Other occasions**  
Set Levers to N Weaving Brushes not in use.



## CHANGE KNOB

**CR**  
This setting is used to release the K-Carriage from the needlebed.

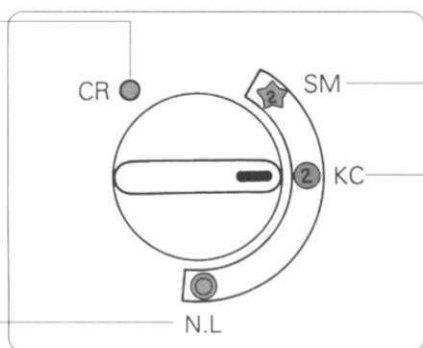

**SM**  
For Single Motifs

**KC**  
For stitch designs that require needle selection.

**N.L.**  
This setting is used for Stocking Stitch, Plating and Lace.

■ The Cam Buttons are automatically released when you set the Change Knob to N.L.

### Needle Selection

During pattern knitting the needles are automatically set into B position or D position according to the pattern.

Punch Card perforations

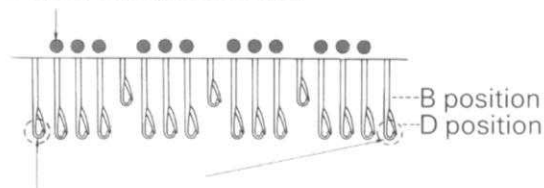

End needles are set into D Position regardless of the pattern sequence by end needle selection mechanism.

## TENSION DIAL

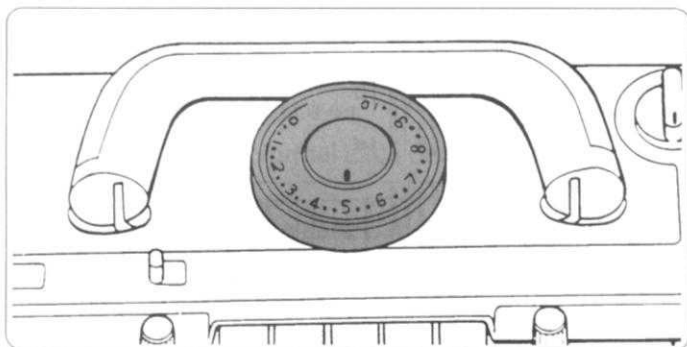

This dial is graduated from 0 to 10, each space being subdivided into three parts. With this dial you can alter the size and tension of your stitches. 0 is the tightest tension (i.e. the smallest stitch) and 10 is the loosest tension (i.e. the largest stitch). You should adjust the dial to a higher or lower number according to the thickness and type of yarn you are using.

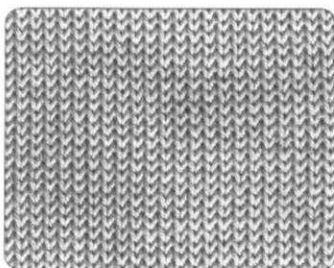

● lower number

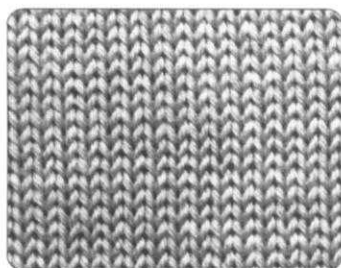

● higher number

TYPE OF YARN	RECOMMENDED TENSION DIAL NUMBER
Very fine yarn	0-3
Fine yarn	3-5
Medium yarn	4-6
Thick yarn	7-10
Very thick yarn	4-6*

As there are so many different types of yarn, it is impossible for us to tell you which Tension Dial Number you should use. You must decide for yourself which is correct for your yarn by working sample swatches. Use the information above as a rough guide only.

\* For very thick or bulky yarns, use every other needle or even every third needle.

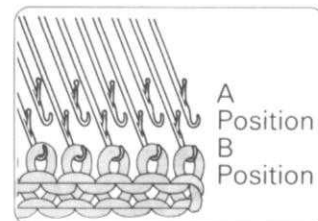

## ● CAST-ON COMB

The Cast-on Comb is in two sections of 140 and 60 needles, making a total of 200 needles. You can take these apart by removing the Connecting Plate if you wish to shorten the length.

- 200 Stitches

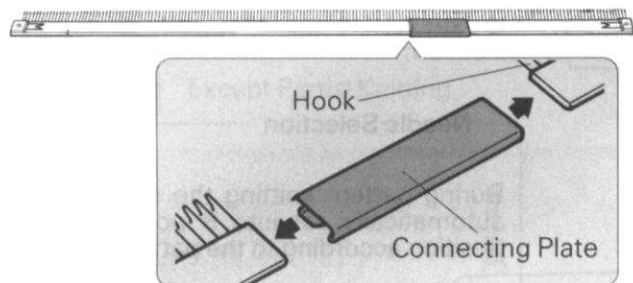

- 140 Stitches



- 60 Stitches



### Using the connecting plate

With a 140 or 60 stitch Cast-on Comb.

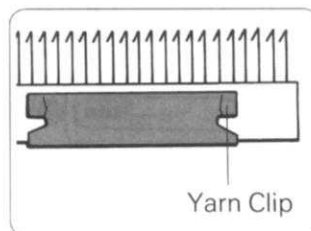

Use the Connecting Plate as a Yarn Clip by attaching it to the end of the Comb.

With a 200 stitch Cast-on Comb.

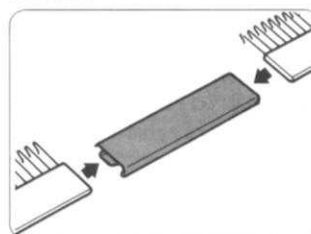

Use the Connecting Plate to join the two Cast-on Combs together.

## ● NEEDLE POSITIONS

On both sides of the needlebed there are the letters A, B, D and E.

A – Non-working position. (NWP)

B – Working position. (WP) Used for general knitting purposes.

D – Upper Working Position. (UWP) Selected needles are brought to this position in pattern knitting by the K or L Carriages.

E – Holding position. (HP) Used for shaping e.g. necklines, shoulders, darts.

♣ When you pack your machine away, always return the needles to A position.

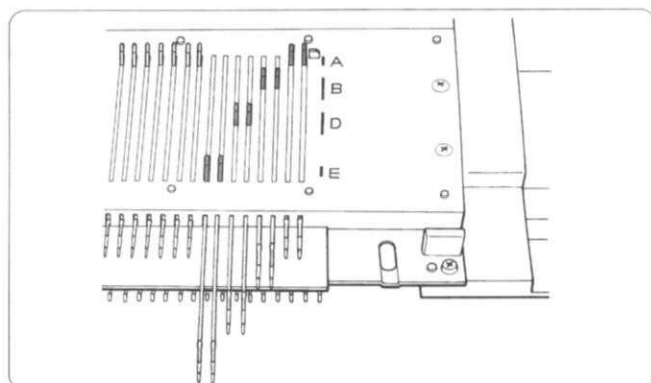

## ● CARRIAGE DIRECTION INDICATOR

The Carriage Direction Indicator shows the direction in which the K or L Carriage is moving.

◀▶ ..... Moving to right

▶◀ ..... Moving to left

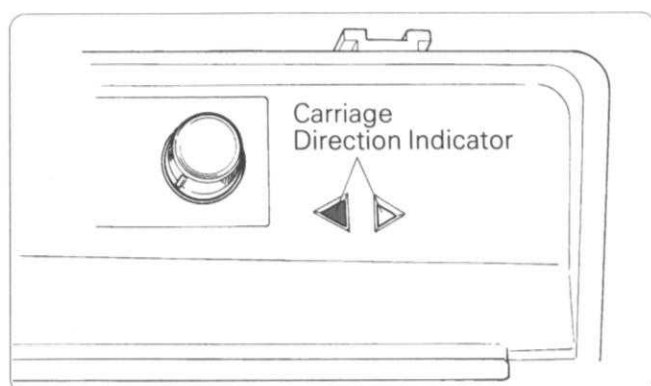



## ● ROW COUNTER

The Row Counter shows the number of rows that have been knitted with the K-Carriage. When you want to set the number back to 000 again, turn the knobs in the direction of the arrows.

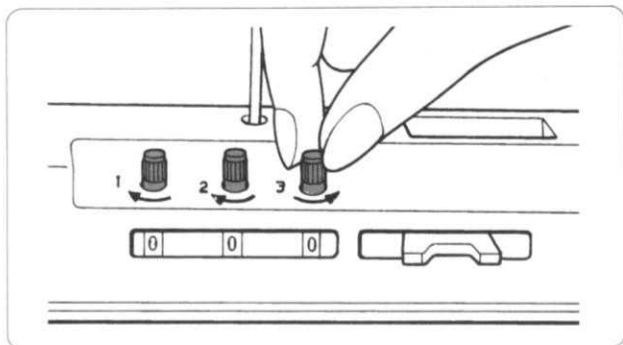

- When using the Row Counter, don't forget to set the Tripper into working position.

Working Position

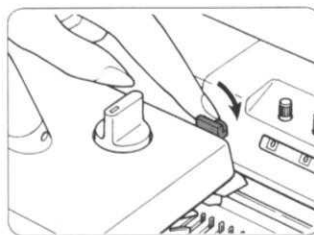

Non-working Position

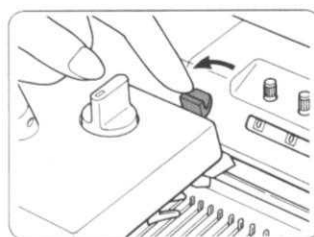

## ● L-CARRIAGE

With the L-Carriage you select and transfer stitches automatically. Use this to make Lace patterns.

Lace Change Lever

- N – Normal Lace pattern knitting
- F – Fine Lace pattern knitting

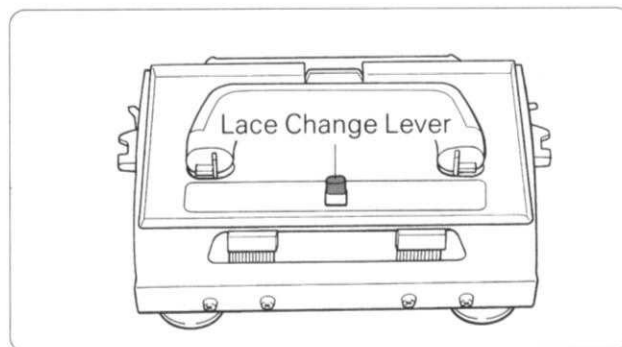

## ● CLAW WEIGHTS

These are used to help your knitting hang properly and to prevent it from lifting up whilst you work.

- Hang Claw Weights onto your Cast-on Comb so that your knitting hangs evenly.

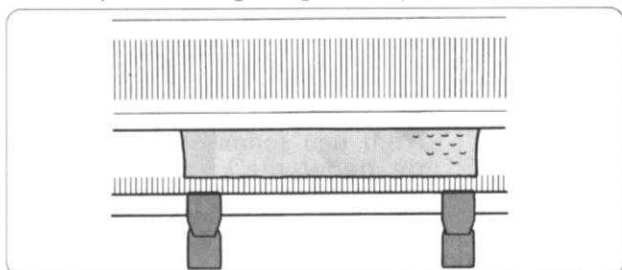

- If the edges of your knitting don't lie smoothly, hang Claw Weights on both edges of the actual knitting.

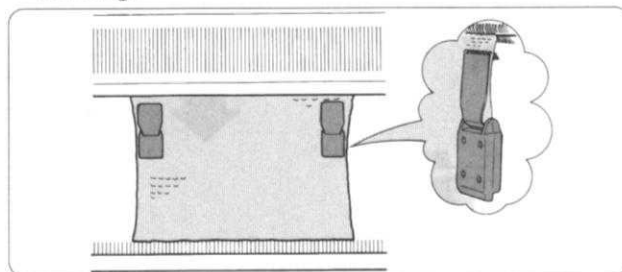

Rehang the weights every 20 rows or so.

# ● END NEEDLE SELECTION MECHANISM OF THE K CARRIAGE

## ● END NEEDLE SELECTION MECHANISM

- The end needle selection mechanism works when the Change Knob is set at KC.
- The end needles will now be automatically selected on each row regardless of the pattern sequence.

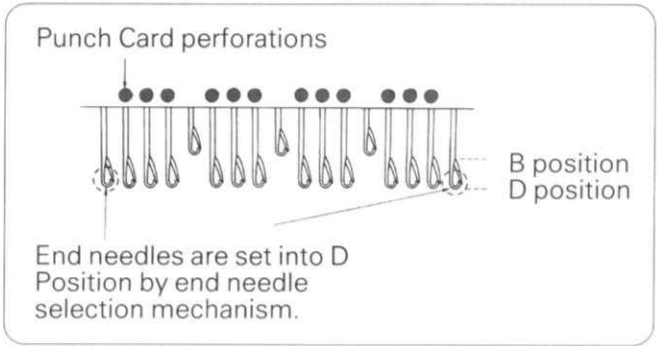
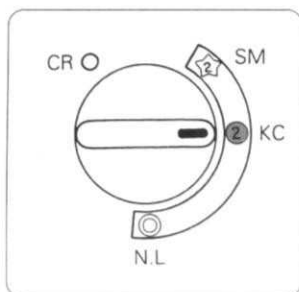

## When knitting Open Stitch Pattern

- When knitting Open Stitch Patterns using a Punch Card (when some of the needles in your pattern remain at A position) you will need to cancel the End Needle Selection Mechanism on both sides of the K-Carriage.

- ① Set the Change Knob at KC.
- ② Remove the K-Carriage from Needle Bed and turn the K-Carriage over.
- ③ Set both End Needle Selection Cams to non-working position as illustrated.
- ④ Place the K-Carriage back onto the Needlebed.

(After you have finished knitting your pattern, don't forget to return the Cams back to working position).

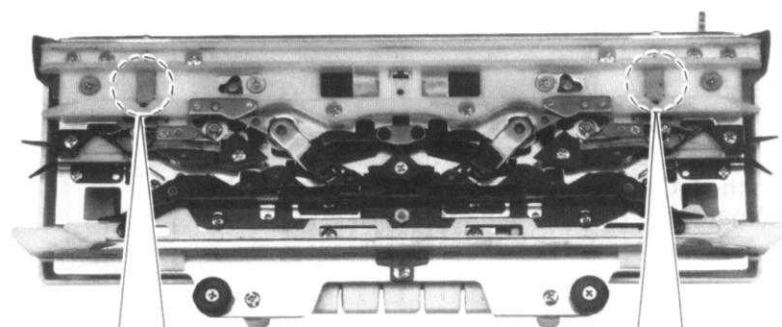

- How to set Cams to Non-Working position.

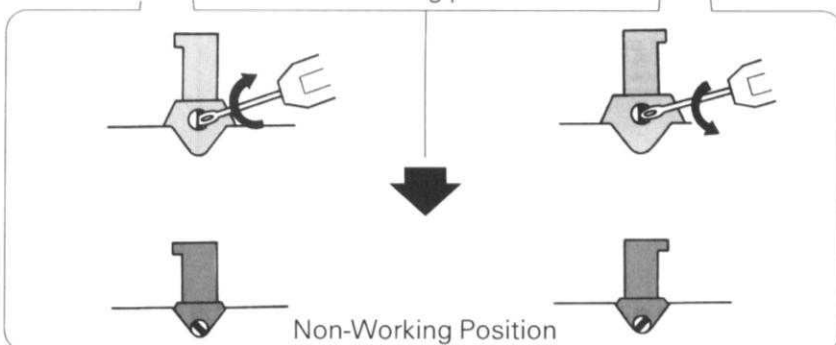

- How to return Cams to Working position.

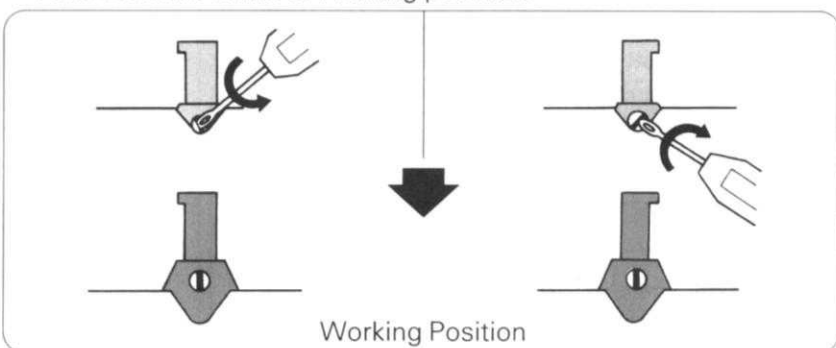



# ● NON-SELECTION MECHANISM OF THE L CARRIAGE

## ● NON-SELECTION MECHANISM

When you move the L-Carriage across the Needle Bed, the needles corresponding to the perforations in the Punch Card are selected to D position.

The non-selection mechanism is built into the L-Carriage, so both end needles will remain in B position regardless of the Punch Card perforations.

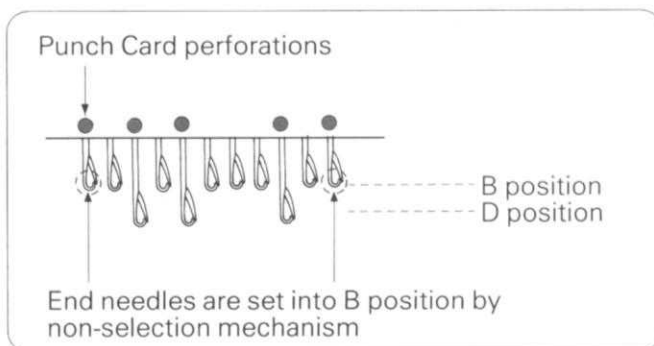

## When knitting Tuck and Lace Pattern or Woven-lace Pattern

When knitting Tuck and Lace Pattern or Woven-lace Pattern with the Punch Card (when some of the needles in your pattern remain at A position) you will need to cancel the working of the Non-selection Mechanism on the L-Carriage and the End Needle Selection Mechanism on the K-Carriage.

- ① Remove the L-Carriage and K-Carriage from Needle Bed and turn them over.
- ② Set both Non-selection Cams on the L-Carriage to non-working position as illustrated.
- ③ Set both End Needle Selection Cams on the K-Carriage to non-working position. (Refer to P.21).
- ④ Place the L and K-Carriages on the Needlebed.

(After you have finished knitting your pattern, don't forget to return the Cams back to working position).

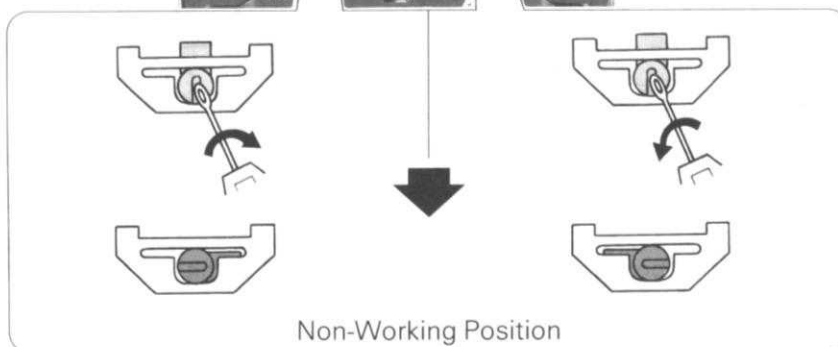
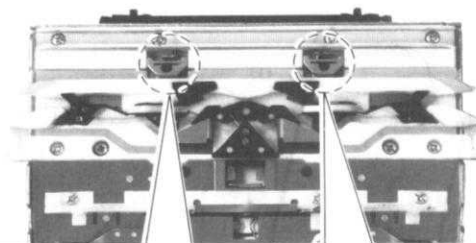

### ● How to return Cams to Working position

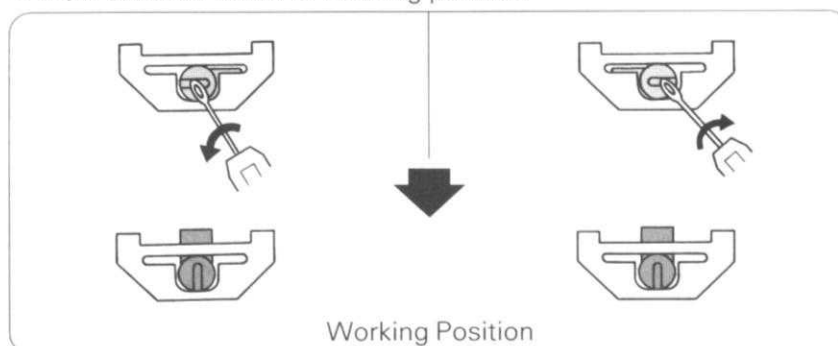

♣ You cannot use the L-point Cam when you have cancelled the working of the non-selection mechanism.

# HOW TO OPERATE YOUR KNITTING MACHINE

## [ STOCKING STITCH (Plain Knitting) ]

Stocking stitch is the most basic and simplest stitch in machine knitting. Practice this until you can do it correctly.

### 1. THREADING THE YARN

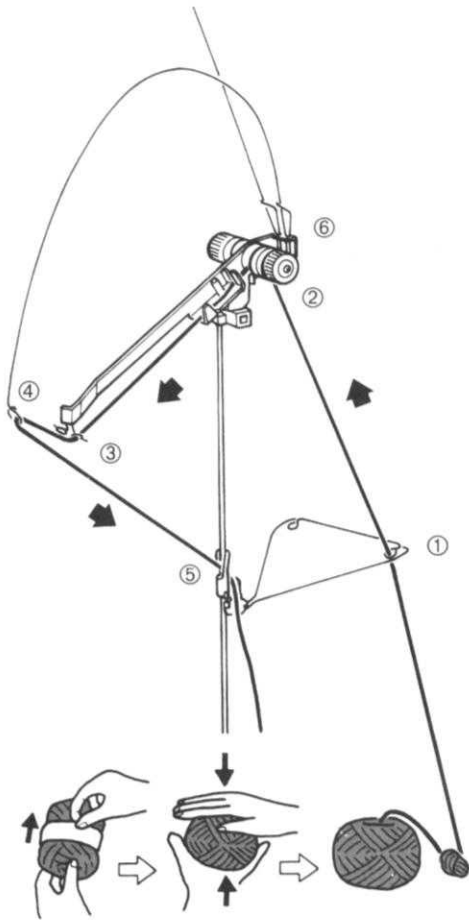

• See page 101 about yarn preparation.

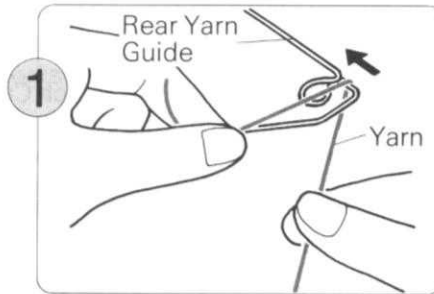

Pass the yarn from the ball through the Rear Yarn Guide sliding the yarn through the eyelet.

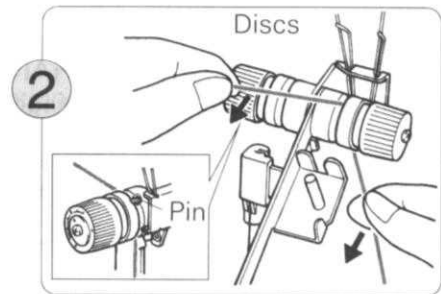

Pass the yarn under the Pin and between the two Discs from behind. Hold the yarn as shown above, and pull it towards you so that the yarn goes under the Pin.

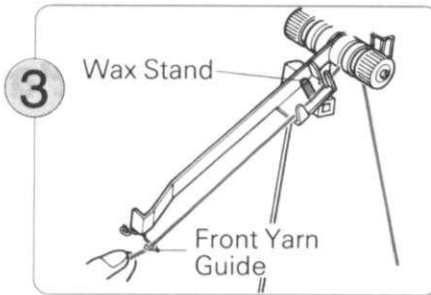

Thread the Front Yarn Guide.

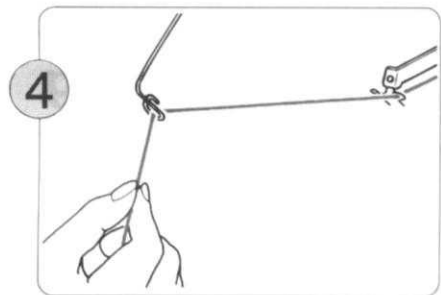

Thread the yarn into the eyelet of the Take-up Spring.

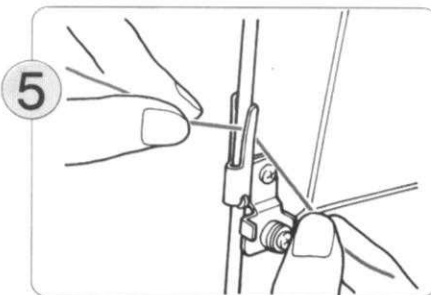

Clip the yarn under the Yarn Clip.

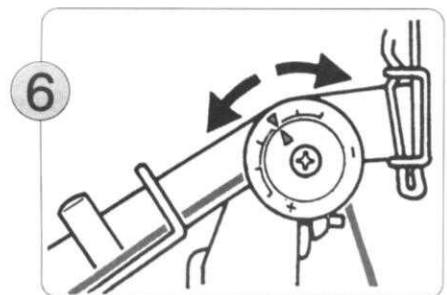

Set the arrow mark according to the thickness of the yarn.

- ▶ ◀ - For Medium Yarn
- ▶ + - For Fine Yarn
- ▶ - - For Thick Yarn

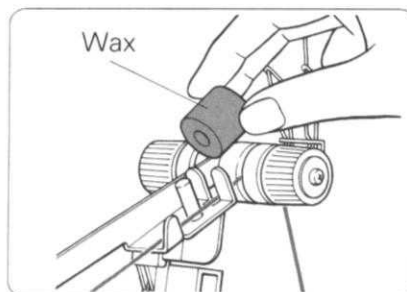

When you start to knit, place the Wax which you will find in the Accessory Box on the Wax Stand. The Wax helps the yarn to slide smoothly.



## 2. HOW TO CAST ON WITH A FINISHED EDGE

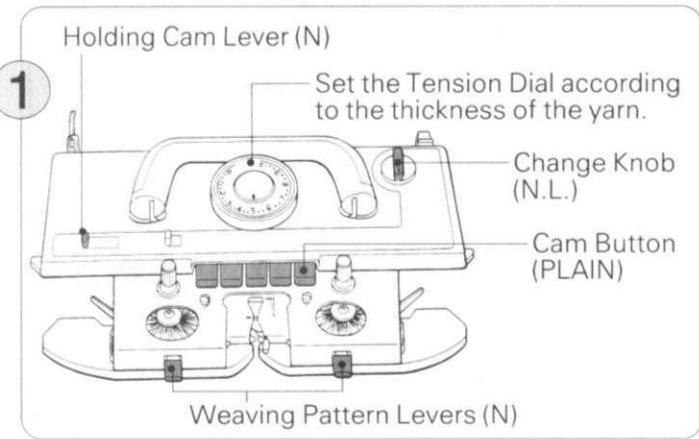

Set the K-Carriage as shown above.

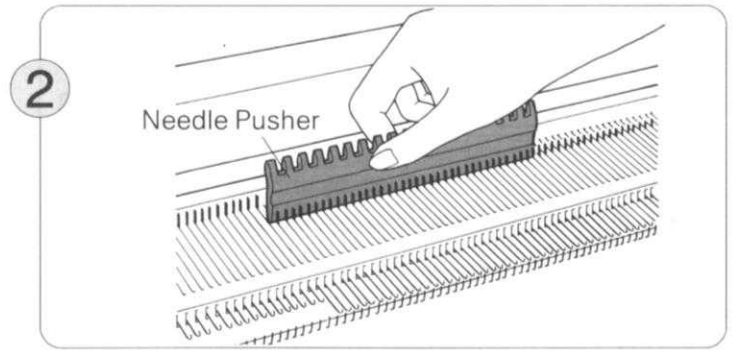

Using the flat side of the 1/1 Needle Pusher, bring forward 60 needles to B position (30 needles on either side of the centre mark "0").

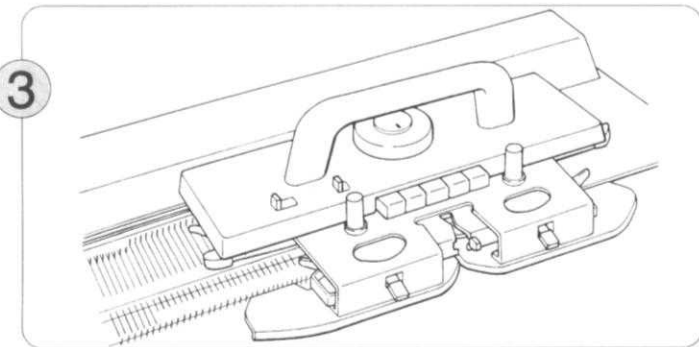

Move the K-Carriage across the needlebed a few times to align the needles, ending with the K-Carriage on the right.

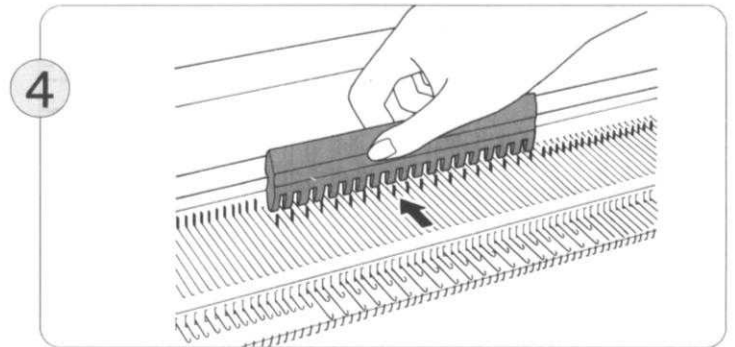

Using the 1/1 Needle Pusher take every other needle back to A position.

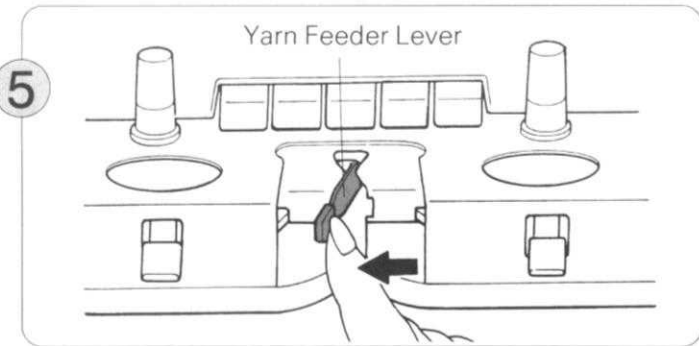

Open Yarn Feeder A by pushing the Yarn Feeder Lever to the left.

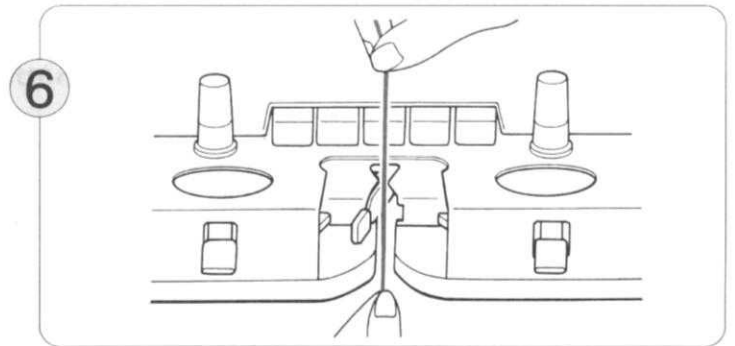

Take the yarn from the Yarn Clip and thread it into Yarn Feeder A.

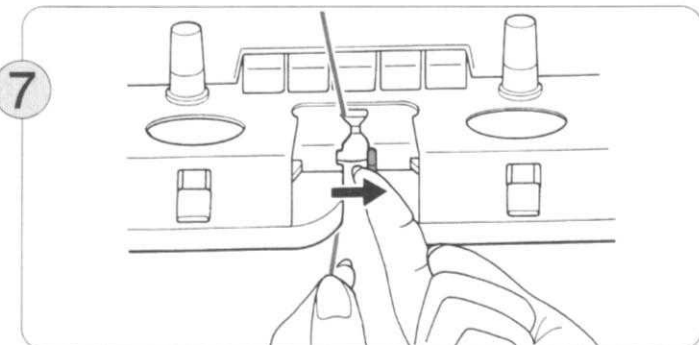

Keeping hold of the end of the yarn with your left hand, close the Yarn Feeder Lever.

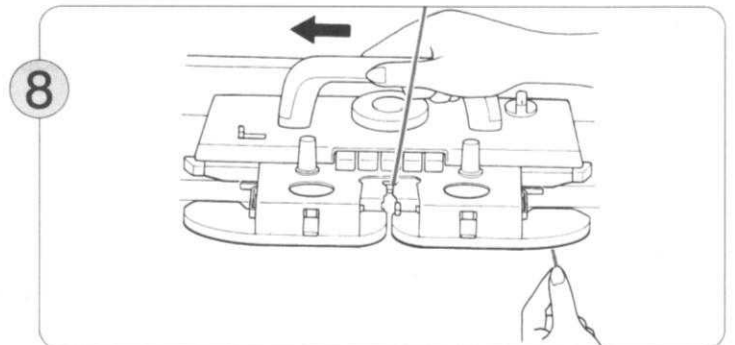

Still holding the yarn end gently, slowly move the K-Carriage to the left. Once you feel the needles catch the yarn, you can release the yarn end.

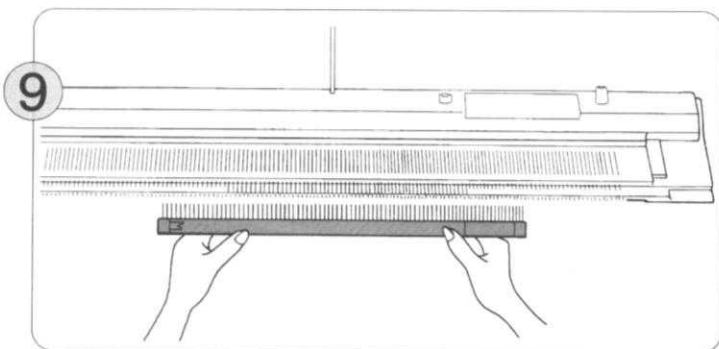

- 9
- (1) Take the Cast-on Comb out of the Case and choose the length according to the number of needles. (See P.19)
  - (2) Hold the Cast-on Comb as shown with the hooks facing the machine.

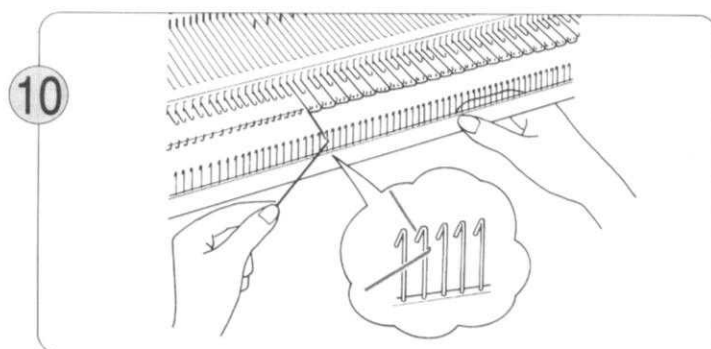

10 Pull the yarn through the hook towards you as illustrated.

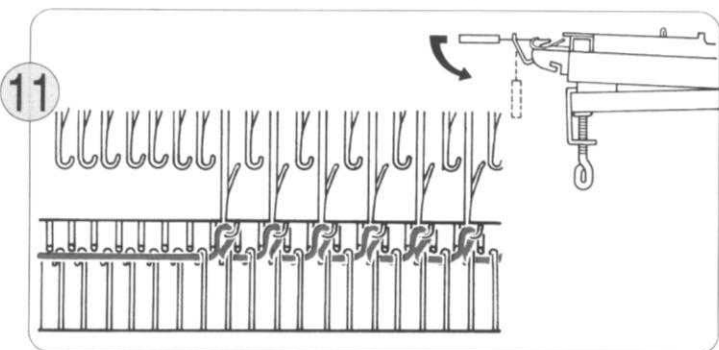

11 Hook the Cast-on Comb over the loops and let it hang down. Give the Comb a gentle pull downwards.

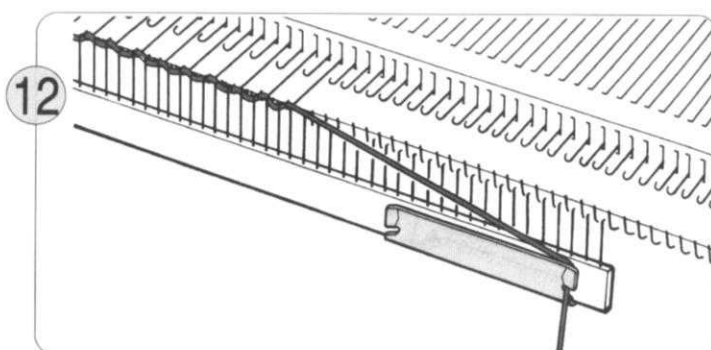

12 Hook the loose yarn end under the Yarn Clip on the front of the Connecting Plate.

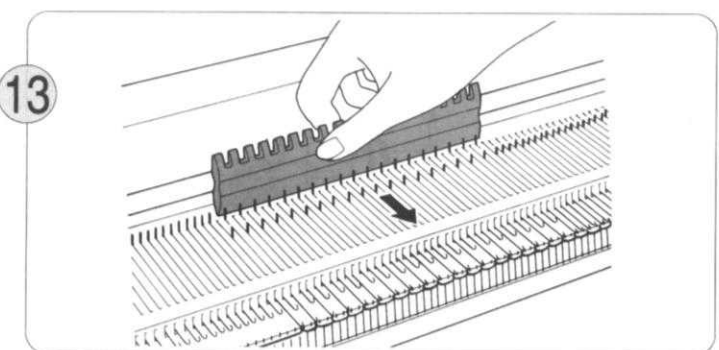

13 Return the needles which you took to A position in Step ④ forward to B position.

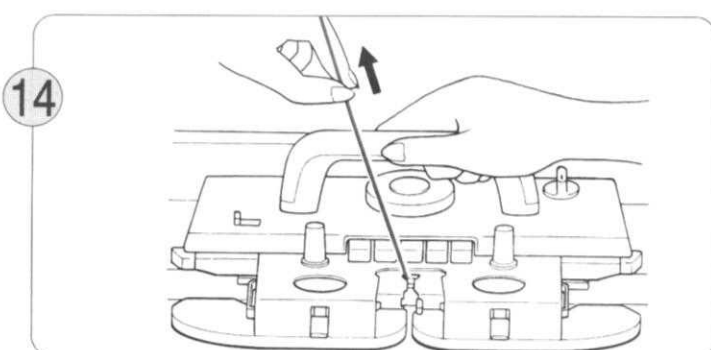

14 Move the K-Carriage to the right, holding the yarn as shown so that no loops are formed.



### 3. STOCKING STITCH

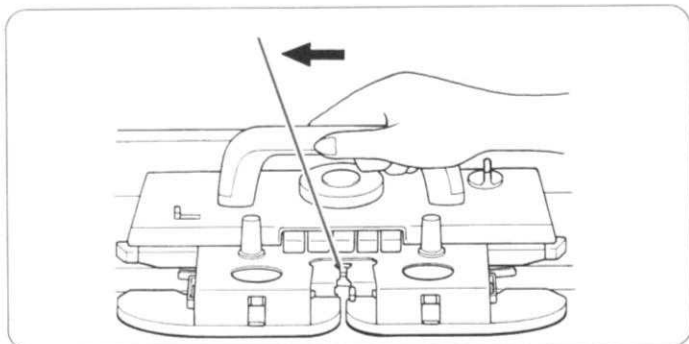

Continue moving the K-Carriage back and forth. This type of knitting is called "Stocking Stitch".

#### Before you move the K-Carriage

- Watch out for the following points

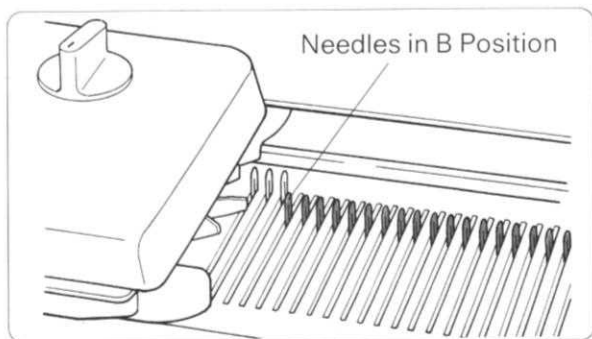

Make sure the K-Carriage (or the L-Carriage) clears the knitting before you move it back in the other direction. You will hear a "Click" at the end of a row.

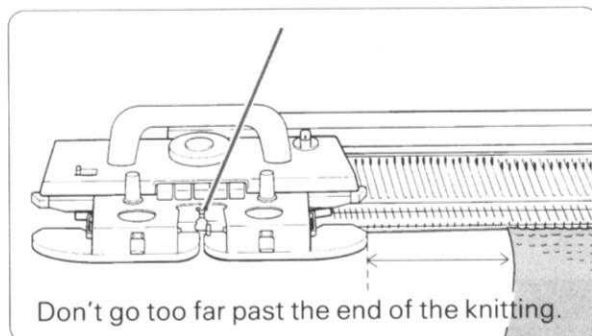

Do not move the K-Carriage too far beyond the knitting.

#### Rubber Wheels (Use these if the yarn (e.g. cotton, acrylic) doesn't knit properly).

- These are set in working position as follows:

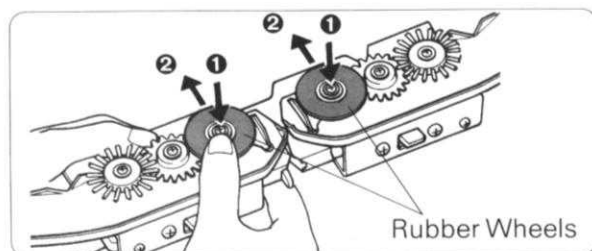

- (1) Remove the Sinker Plate Assembly from the K-Carriage, and turn it over.
  - (2) Place your thumb onto one of the Rubber Wheels and slide the Wheel forward, so that it is in line with the Brush. Do the same for the other Rubber Wheel.
- ♣ Reverse the above action to return the Rubber Wheels to non-working position.

#### Plain & Purl Sides of your Knitting

- You can use whichever side you prefer as the right (face) side when you sew up your garment.

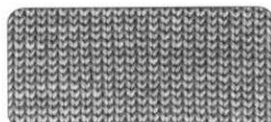
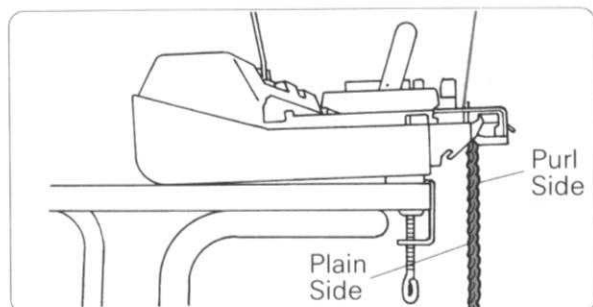

• Plain Side

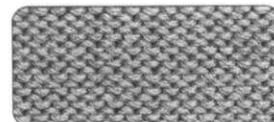

• Purl Side

## 4. HOW TO REMOVE YOUR KNITTING FROM THE MACHINE

1

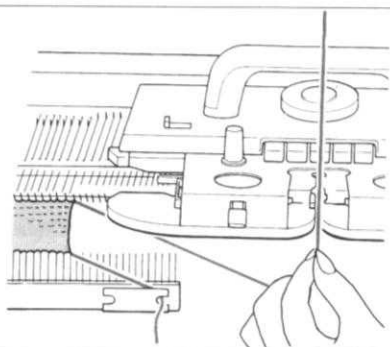

Remove the Claw Weights and take the yarn out of Yarn Feeder.

2

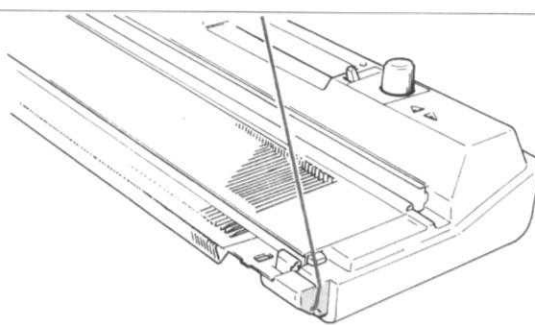

Secure the yarn by hooking it into the slot at the edge of your machine.

3

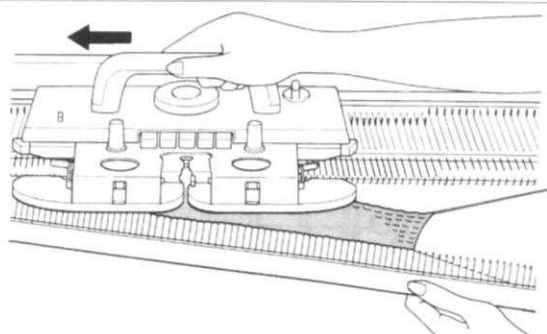

To release the knitting, move the empty K-Carriage slowly across the needles at the same time supporting the knitting with your other hand.

4

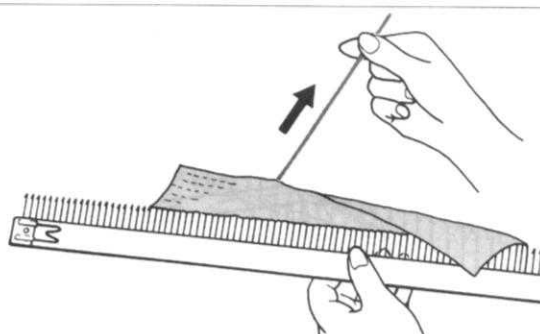

As the knitting has not been finished off and the stitches are open loops, it will unravel easily.

### How to remove your knitting from the machine whilst you are knitting in pattern

- Set the Change Knob to N.L and the Holding Cam Lever to N. And then follow the steps ①-④ on this page.

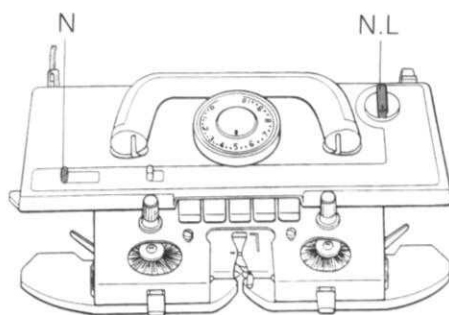



# PATTERN KNITTING

## [ PUNCH CARD AND THE PATTERN ]

Card No. 11



- There are 20 different Punch Cards included with your machine as accessories.
- It is possible to knit several different fancy stitch patterns from the same Punch Card. (Refer to the chart on P.104).

The following are examples using Card No. 11.

### SKIP STITCH PATTERN

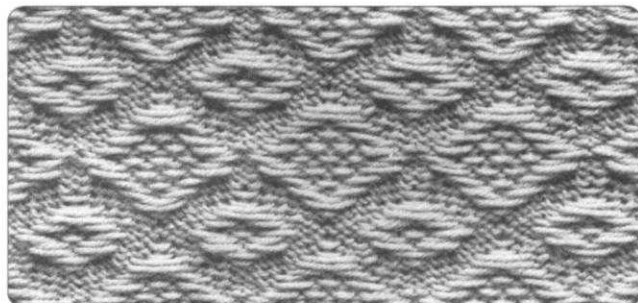
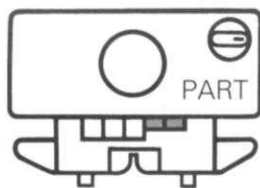

### FAIR ISLE PATTERN

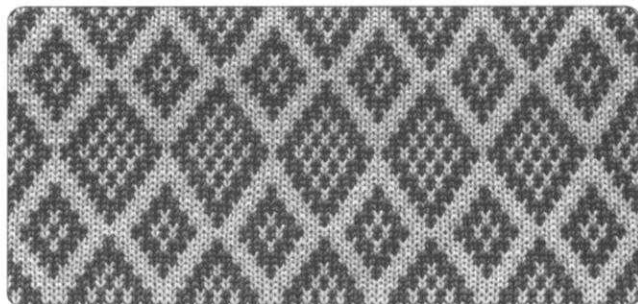
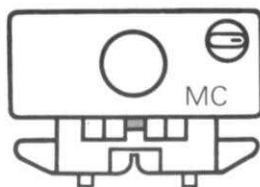

### WEAVING PATTERN

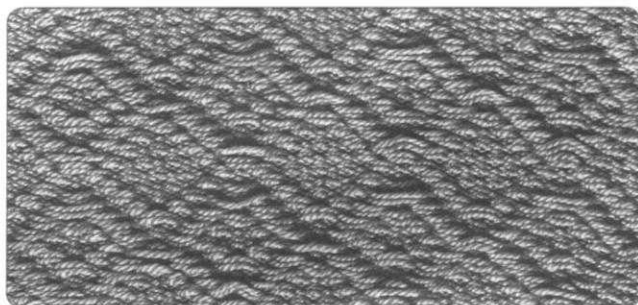
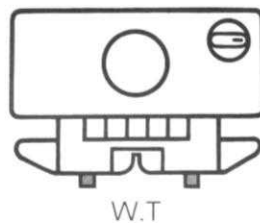

# [ RELATIONSHIP BETWEEN THE PUNCH CARD AND THE NEEDLES ]

A punch card is 24 stitches wide. Each line on the punch card covers one group of 24 needles. (e.g. the 12 needles on either side of the centre "0").

Each 24 stitch needle group as marked by red lines on the Needle Position Indicator is equal to one width of the punch card. This may be one complete 24 stitch pattern or several repeats of smaller patterns.

Needles corresponding to the perforations punched in the card are selected to D position.

During pattern knitting (when the Change Knob is set at KC or SM), the needles are automatically set into B position or D position according to the pattern.

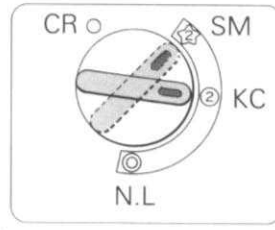

Perforation in the Punch Card

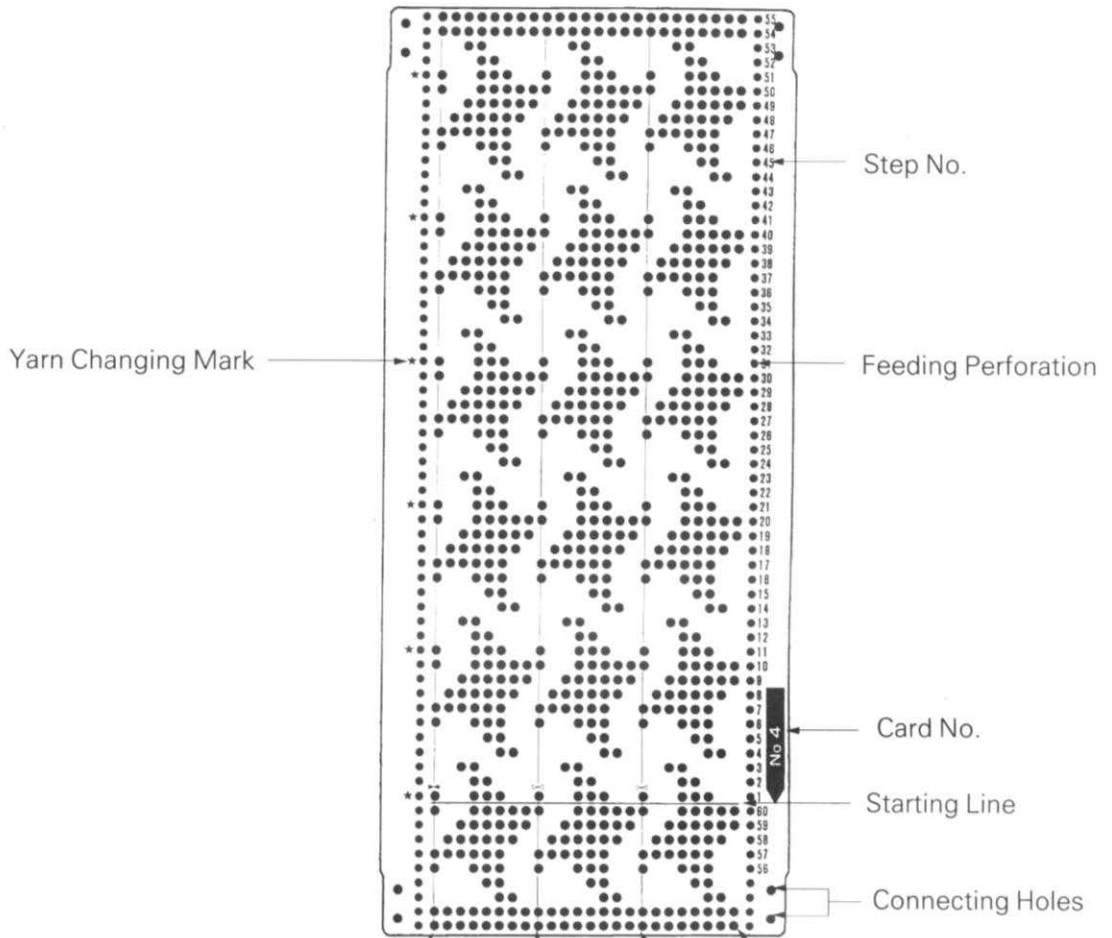
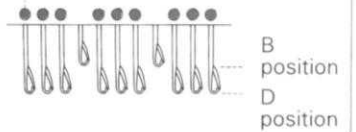

Yarn Changing Mark

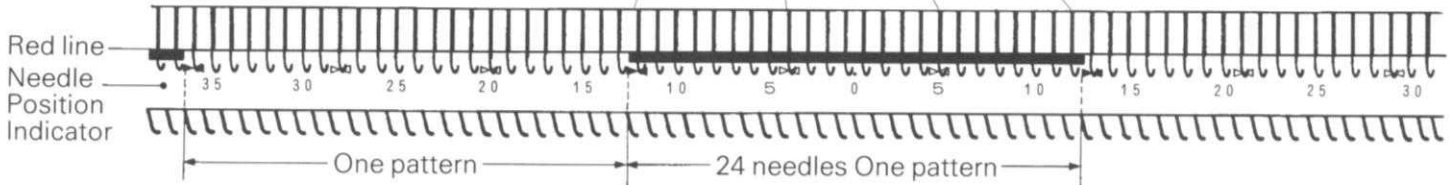

■ Do not fold the Punch Cards.

# [ HOW TO SET THE PUNCH CARD ]

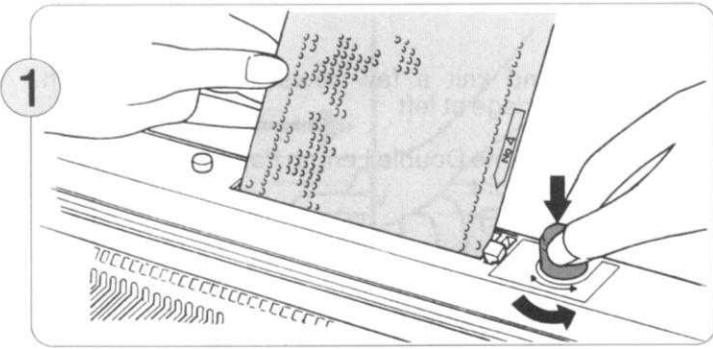

With the number facing you, insert the bottom edge of the Punch Card into the slot. Make sure you hold the Punch Card straight.

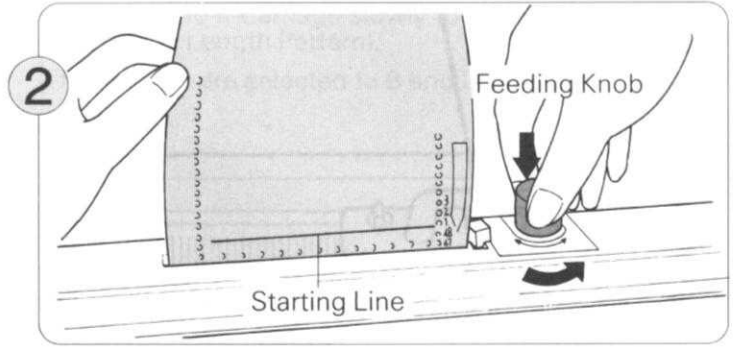

Feed the Punch Card into the opening, making sure that the line on the Card is parallel with the top of the slot.

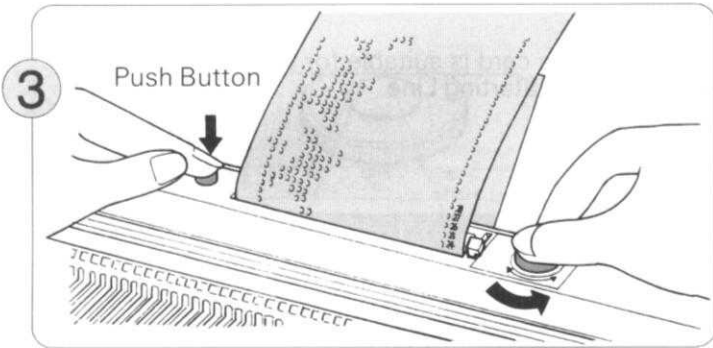

It is easier to operate the Feeding Knob if you press down on the Push Button at the same time.

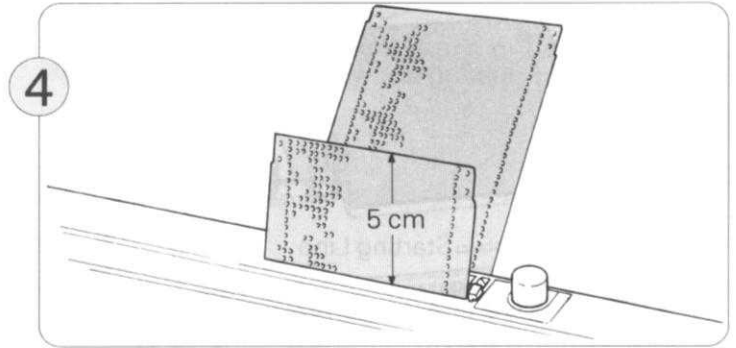

Feed the Punch Card until it comes out from the card opening by 5 cm.

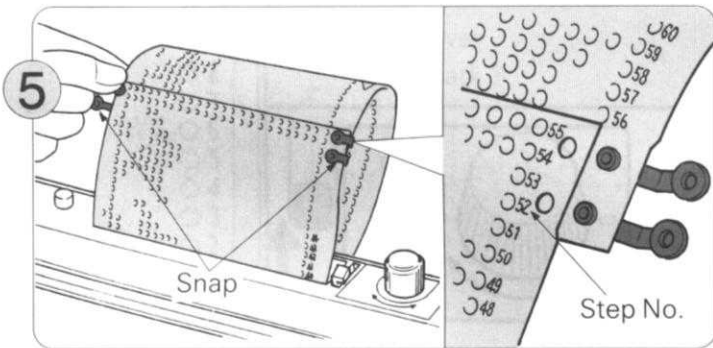

Using the plastic snaps, join the card to allow it to rotate. When joined together, the numbers on the Card must continue in the right sequence.

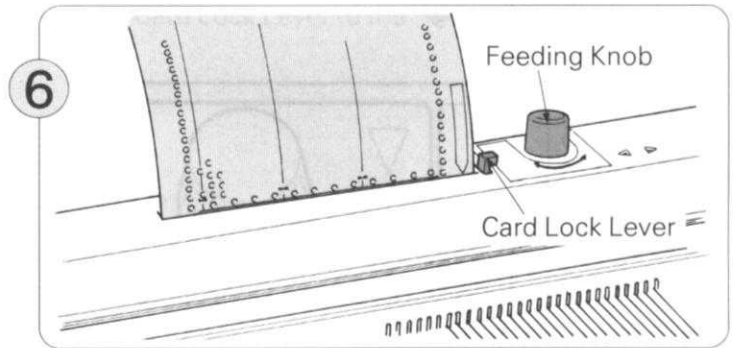

Turn the Feeding Knob and rotate the Card to the starting line. Set the Card Lock Lever to the "o" mark.

## NOTE:

- You can check if the needles are selected correctly using the Feeding Knob. (Refer to P.68).
- Punch Card moves down by 7 rows before it reaches the patterning mechanism.



# [ BASIC STEPS TO PATTERN KNITTING ]

The first steps to all patterning are the same, so study these carefully.

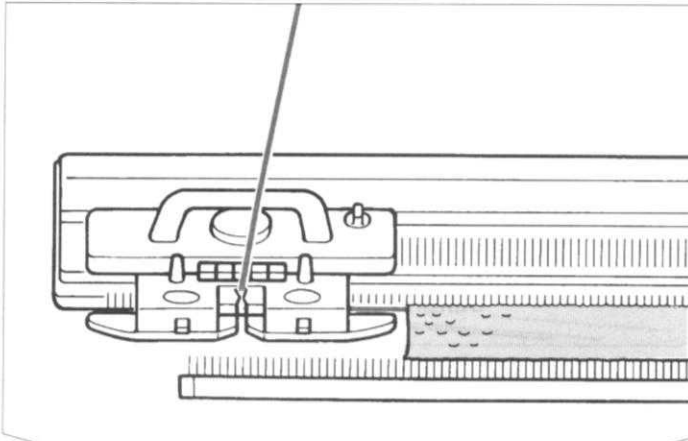

## STEP 1

- 1 Cast on and knit a few rows in stocking stitch. Place K-Carriage at left.
- ♣ When knitting the Double Length Pattern, place the K-Carriage at right.

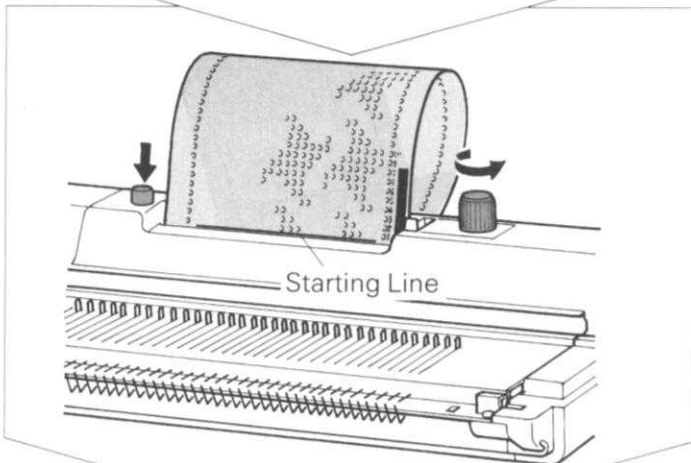

- 2 Insert card.

Check that the card is suitable for the stitch wanted. Rotate card to Starting Line.

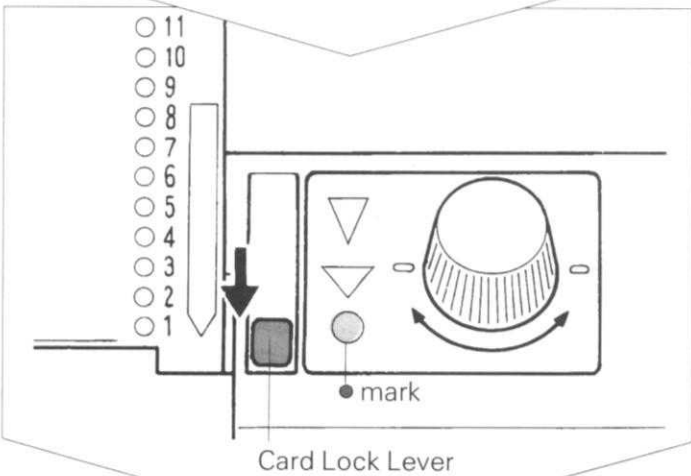

- 3 Set the Card Lock Lever to the "o" mark.

## STEP 2

- 1 Set the Change Knob to KC.
- ♣ When knitting Motif Pattern, set it to SM.

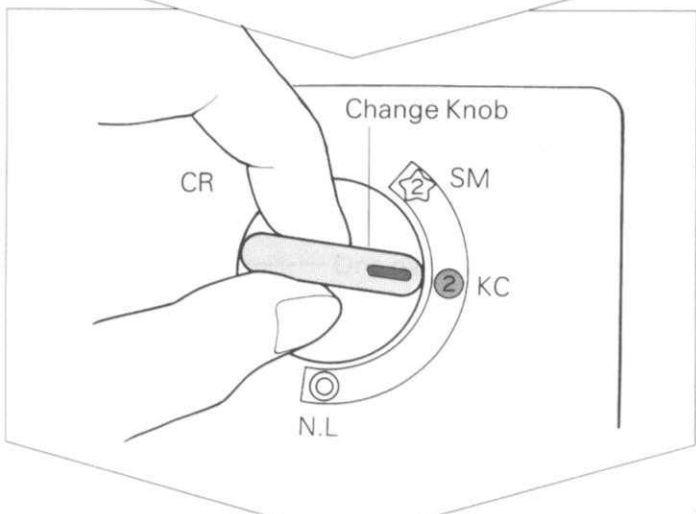

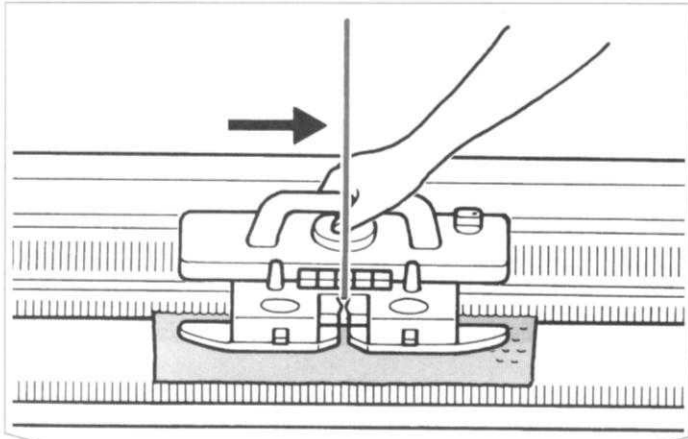

**2** Move the K-Carriage slowly to the right (to the left in Double Length Pattern).

The needles are selected to B and D positions.

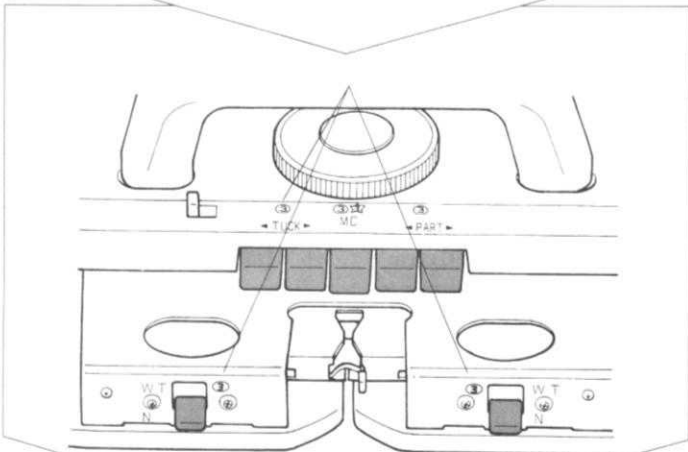

### STEP 3

Push the appropriate Cam Buttons or set the Weaving Pattern Lever according to your pattern.

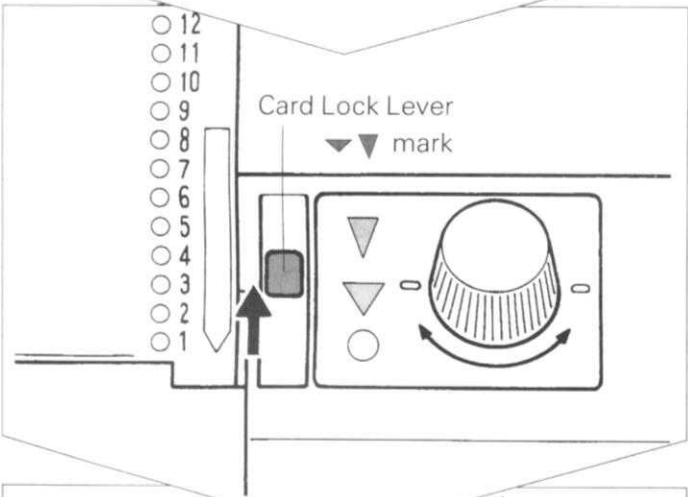

### STEP 4

Set the Card Lock Lever to the "▼" or "▼" mark.

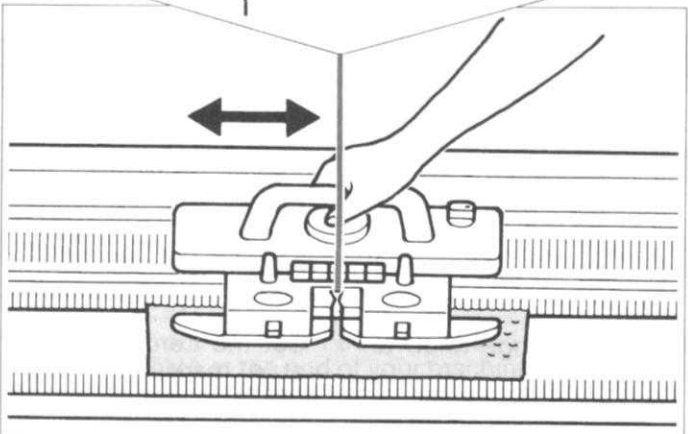

Begin knitting.

# 【 SKIP STITCH PATTERN Card No. 1,2,3,5,7,8,11 】

Example: Card No. 5

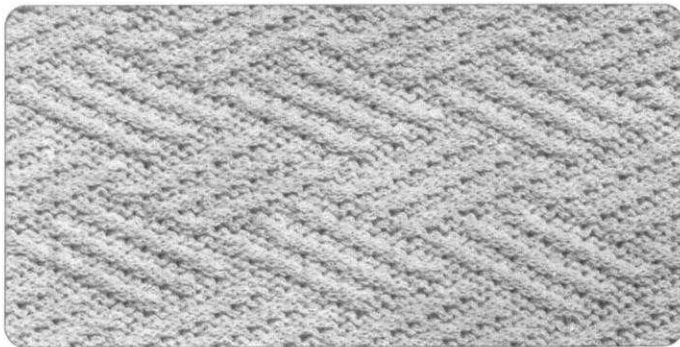

## ● PATTERN KNITTING

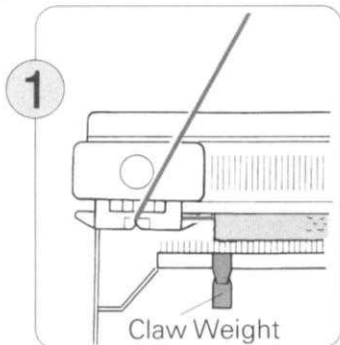

Knit a few rows in stocking stitch and place the K-Carriage on the left side of the machine. Hang the Claw Weights evenly along the Cast-on Comb.

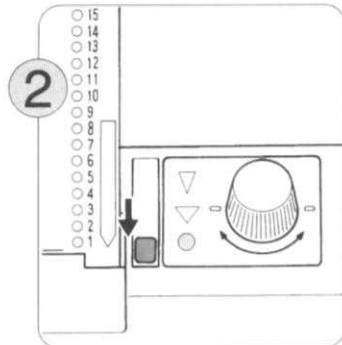

Insert the Punch Card and rotate it to Starting Line. Set the Card Lock Lever at "●" mark.

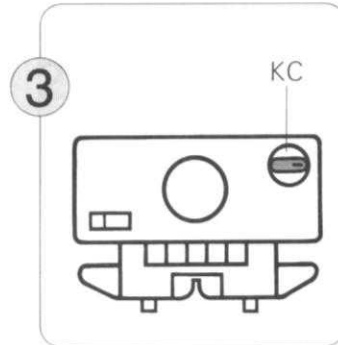

Set the Change Knob to KC.

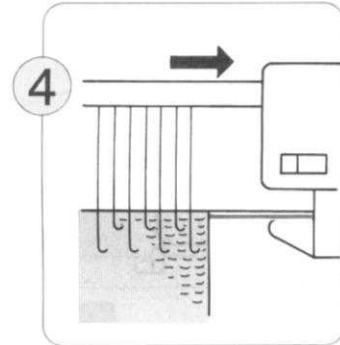

Move the K-Carriage from left to right. The needles are selected.

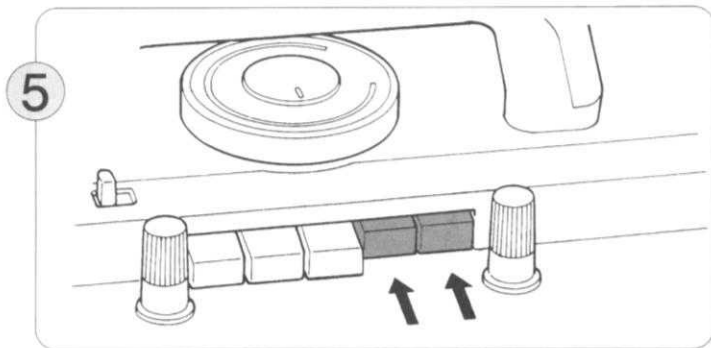

Push both Part Buttons at the same time.

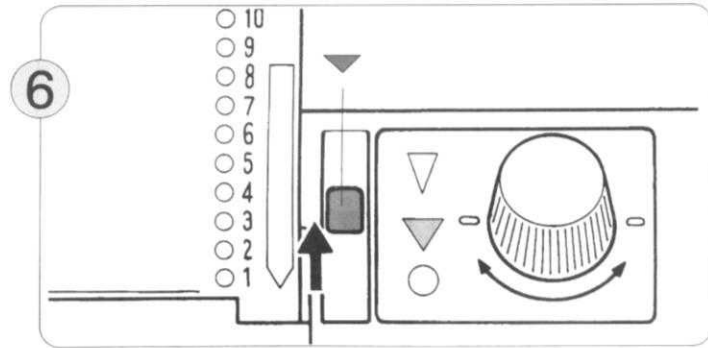

Set the Card Lock Lever at "▼" mark.

### ● To finish pattern knitting ...

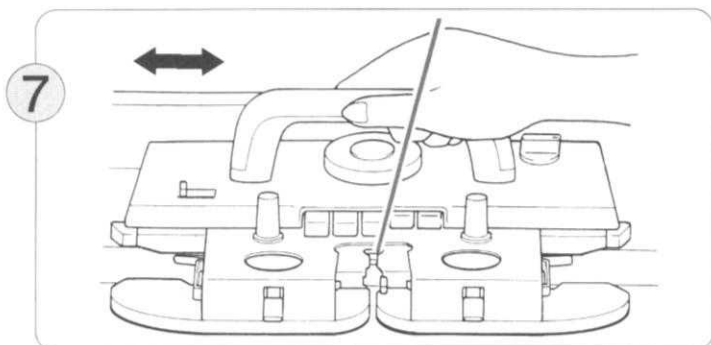

Move the K-Carriage back and forth. You are knitting in Skip Stitch Pattern.

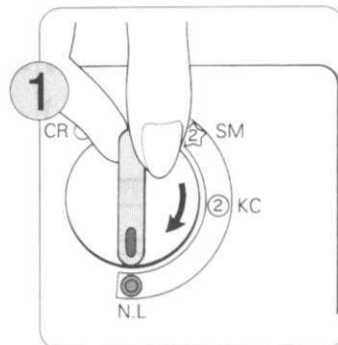

Set the Change Knob to N.L. The Cam Buttons will be automatically released.

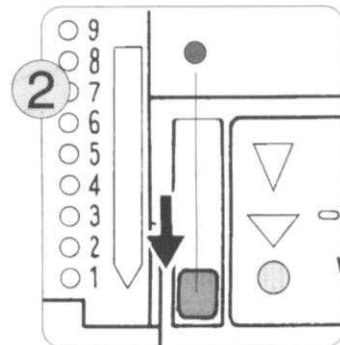

Set the Card Lock Lever at "●" mark.



# [ MULTI-COLOUR SKIP STITCH PATTERN Card No. 1,2,3,5,7,8,11 ]

## Example: Card No. 7

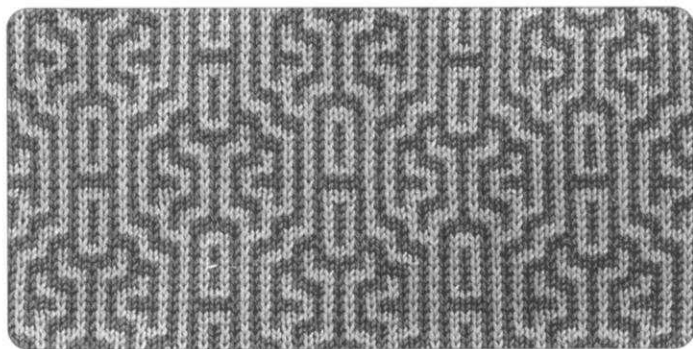

- This pattern is the same as Skip Stitch Pattern, except the yarn is changed every two rows.

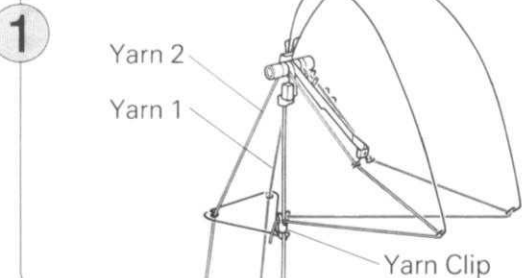

Thread Yarn 1 into the righthand Yarn Tension Unit and Yarn 2 into the lefthand one. Follow the steps ① – ⑥ on P.33.

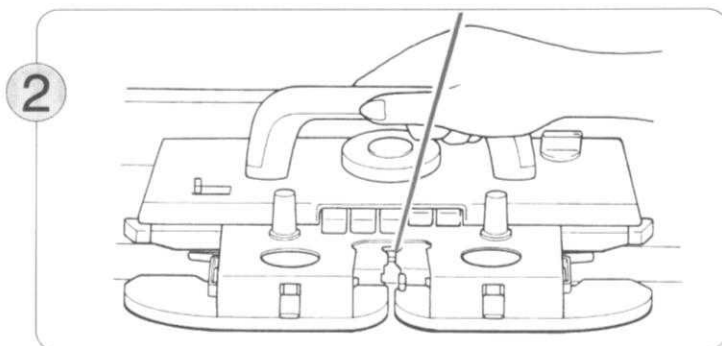

Then knit two rows.

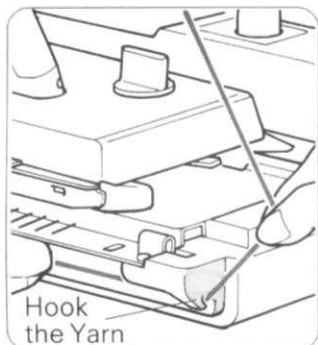
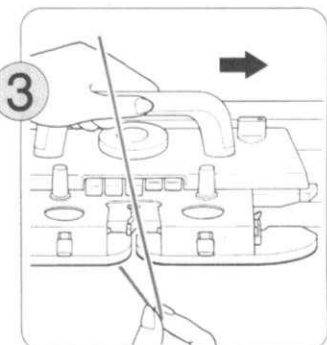

Take Yarn 1 out of Yarn Feeder "A". If you slide the K-Carriage slightly to the right the yarn can be removed easily. Hook Yarn 1 around the notch at the end of your machine.

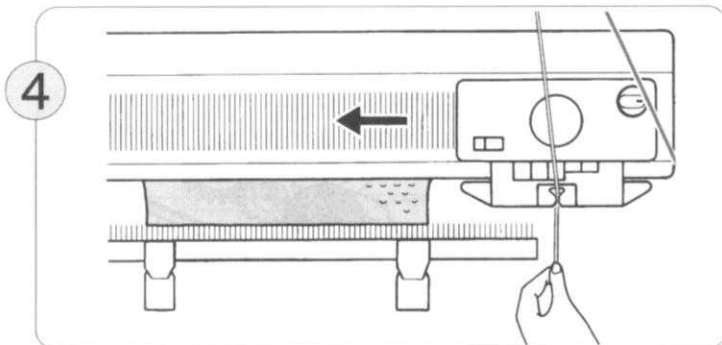

Thread Yarn 2 into Yarn Feeder "A" and knit two rows.

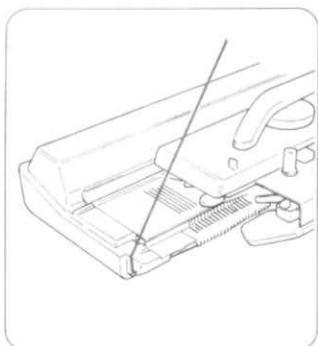
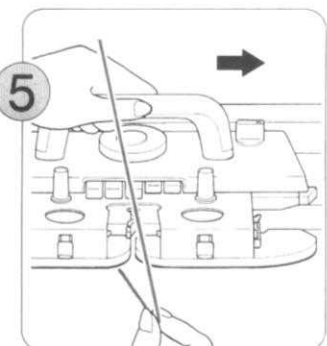

Take Yarn 2 out of Yarn Feeder "A" and hook Yarn 2 around the notch at the end of your machine.

♣ Hook Yarn 1 around the notch at the right end of your machine and Yarn 2 around the notch at the left end.

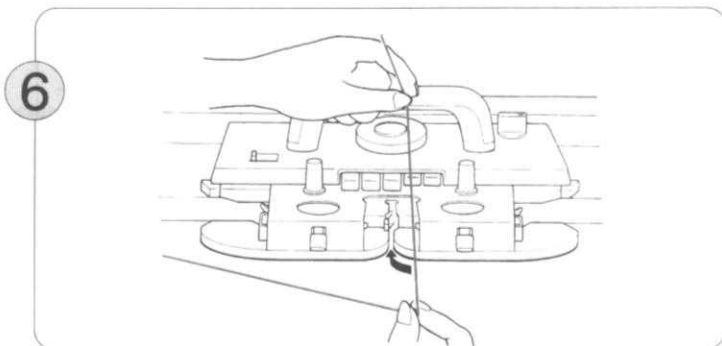

Thread Yarn 1 into Yarn Feeder "A" and knit two rows. Change the Yarn in the Yarn Feeder "A" every two rows. (When you change the yarns, take care not to cross them over each other.)

# 【 TUCK STITCH PATTERN Card No. 1,2,3,7,8 】

Example: Card No. 2

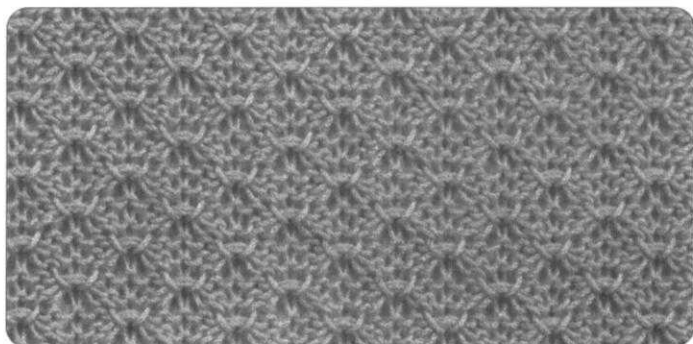

## ● PATTERN KNITTING

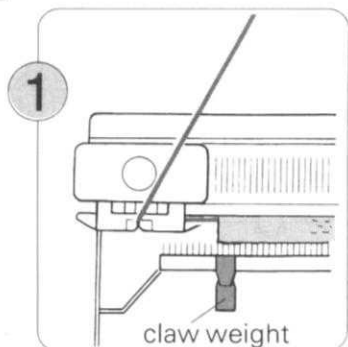

Knit a few rows in stocking stitch and place the K-Carriage on the left side of the machine. Hang the Claw Weights evenly along the Cast-on Comb.

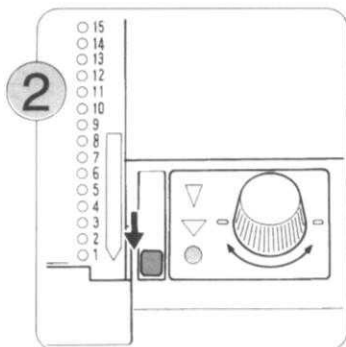

Insert the Punch Card and rotate it to Starting Line. Set the Card Lock Lever at "●" mark.

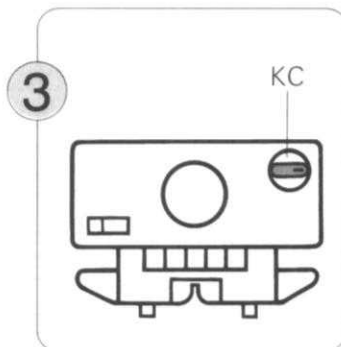

Set the Change Knob to KC.

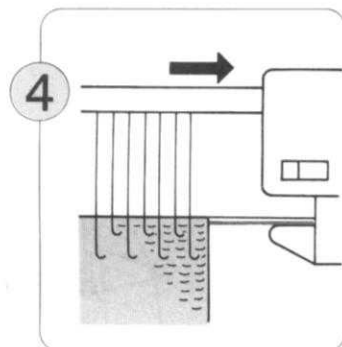

Move the K-Carriage from left to right. The needles are selected.

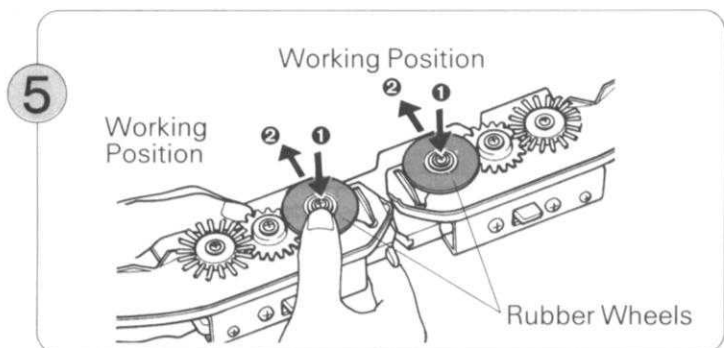

Remove the Sinker Plate Assembly from the K-Carriage and turn it over. Put the Rubber Wheels into working position ⊙ as shown. Attach the Sinker Plate Assembly back on the K-Carriage again.

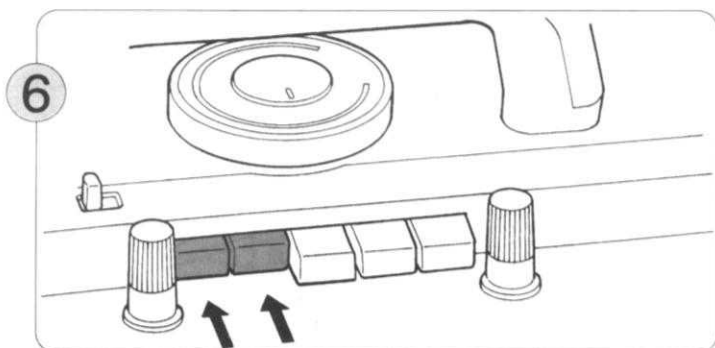

Push both Tuck Buttons at the same time.

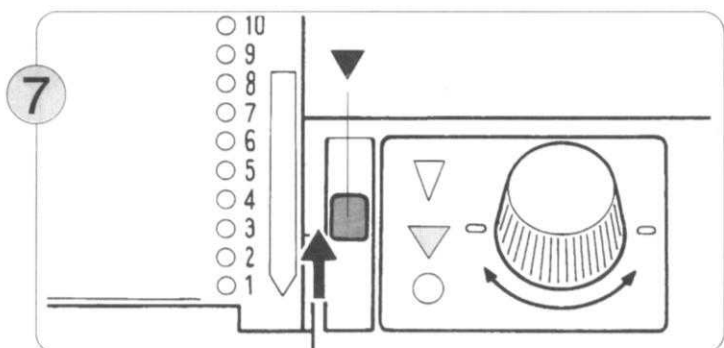

Set the Card Lock Lever at "▼" mark.

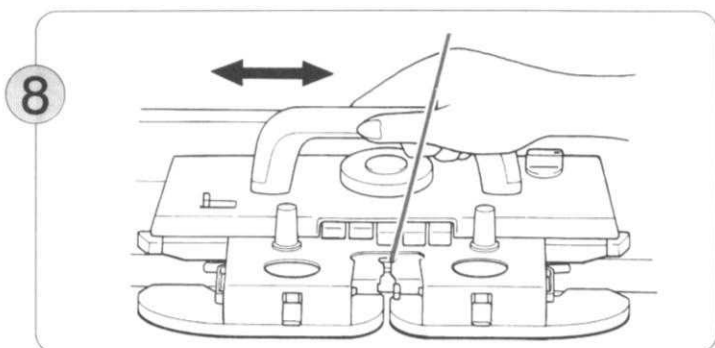

Move the K-Carriage back and forth. You are now knitting in Tuck Stitch Pattern.

• To finish pattern knitting ...

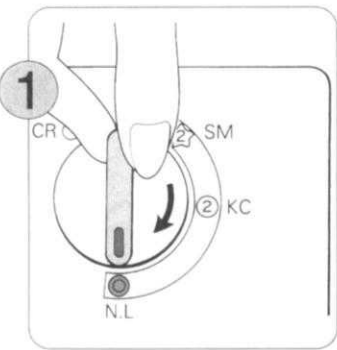

Set the Change Knob to N.L. The Cam Buttons will be released automatically.

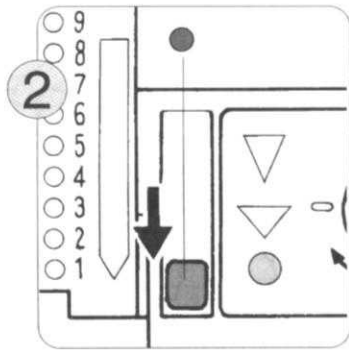

Set the Card Lock Lever at "●" mark.

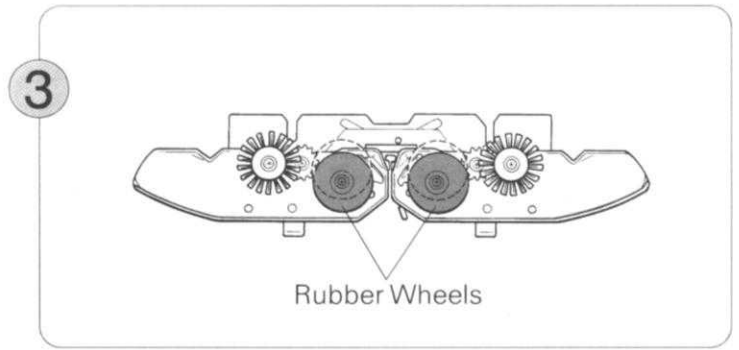

Place the Rubber Wheels in non-working position.

## [ MULTI-COLOUR TUCK STITCH PATTERN Card No. 1,2,3,7,8 ]

**Example: Card No. 2**

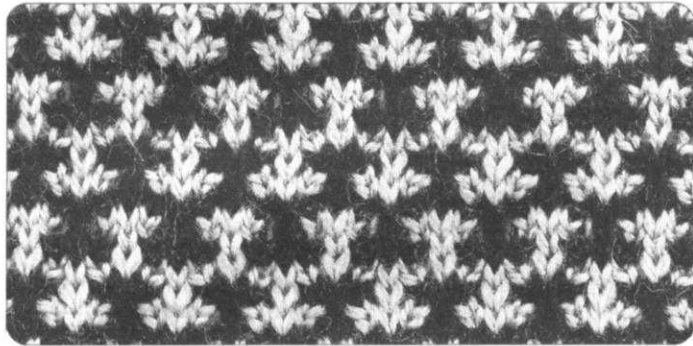

• This is worked the same as Tuck Stitch Pattern, except the yarn is changed every two rows.

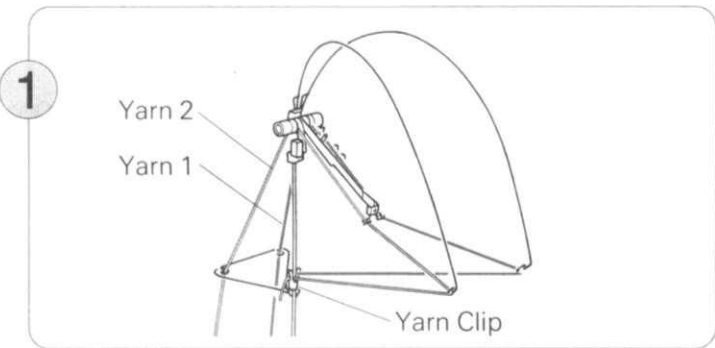

Thread Yarn 1 into the righthand Yarn Tension Unit and Yarn 2 into the lefthand one. Follow the steps ① - ⑦ on P.35.

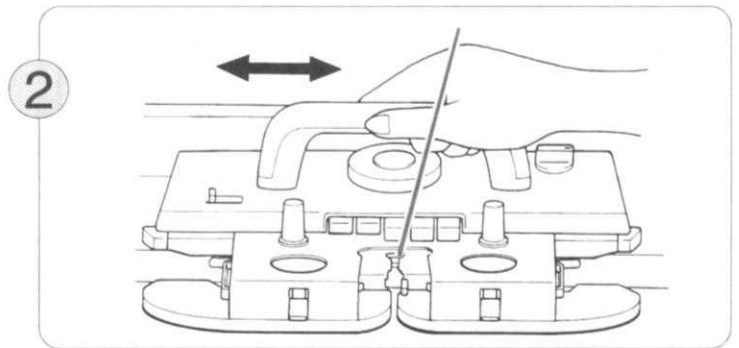

Then knit two rows.

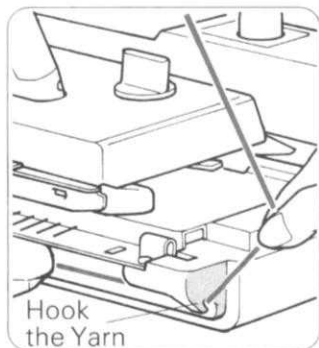
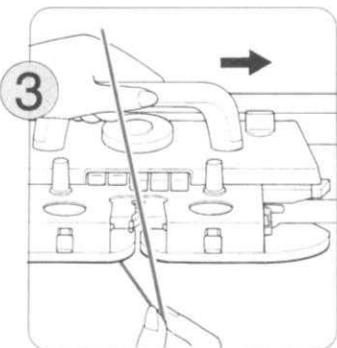

Take Yarn 1 out of Yarn Feeder "A". If you slide the K-Carriage slightly to the right the yarn can be removed easily. Hook Yarn 1 around the notch at the end of your machine. (Refer to ③ & ⑤ on P.34.)

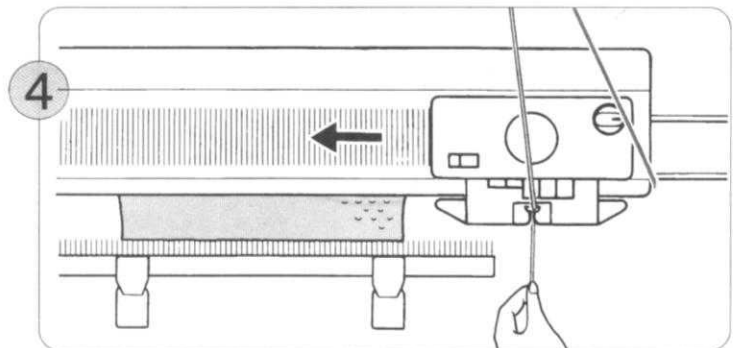

Thread Yarn 2 into Yarn Feeder "A" and knit two rows. Change the Yarn in Yarn Feeder "A" every two rows. (When you change the yarns, take care not to cross them over each other.)



# 【 WEAVING PATTERN Card No. 1,2,3,5,7,8,11 】

## Example: Card No. 7



- This example requires two types of yarn—the main yarn and the weaving yarn.
- A better effect will result if you choose a weaving yarn that is thicker than the main yarn.

### • THREADING THE YARN

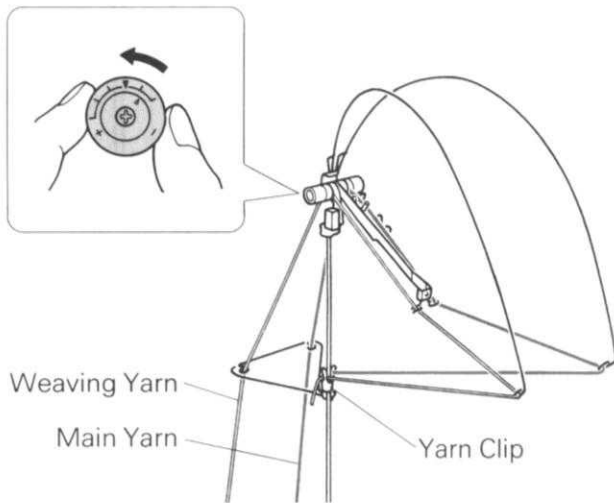

Thread the main yarn into the righthand Yarn Tension Unit and the weaving yarn into the lefthand one. Adjust the Tension Disc as shown according to the weaving yarn.

### • PATTERN KNITTING

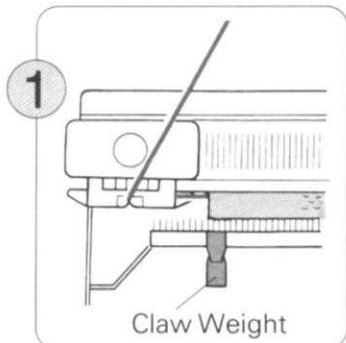

Knit a few rows in stocking stitch and place the K-Carriage on the left side of the machine. Hang the Claw Weights evenly along the Cast-on Comb.

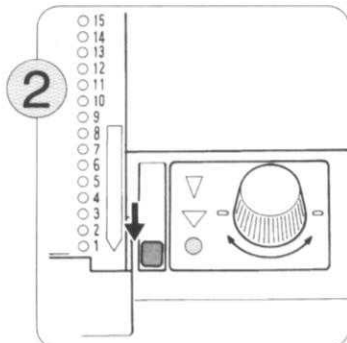

Insert the Punch Card and rotate it to Starting Line. Set the Card Lock Lever at "●" mark.

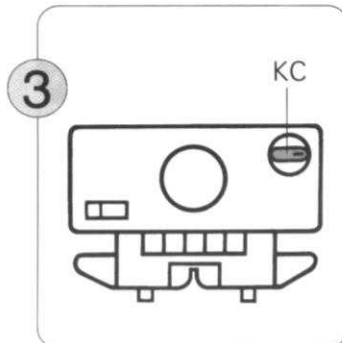

Set the Change Knob to KC.

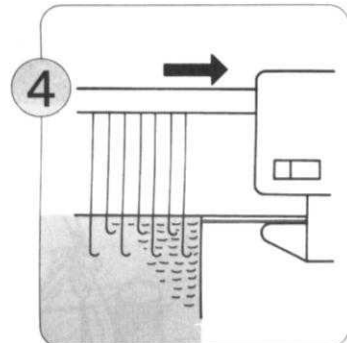

Move the K-Carriage from left to right. The needles are selected.

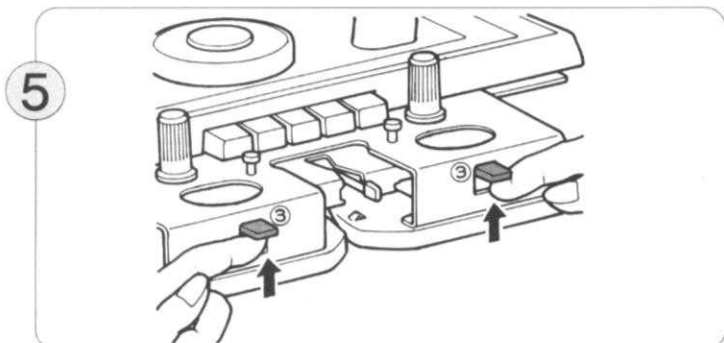

Set the Weaving Pattern Levers to W.T.

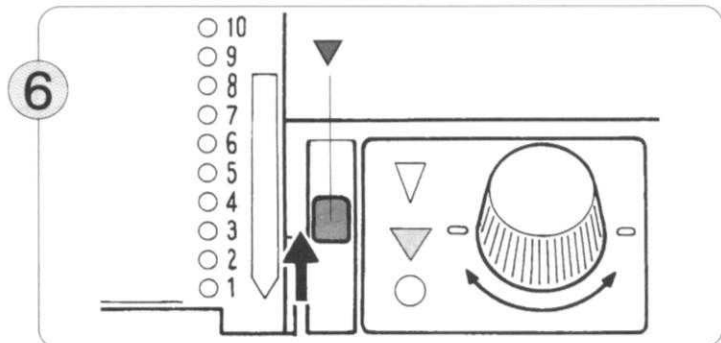

Set the Card Lock Lever at "▼" mark.

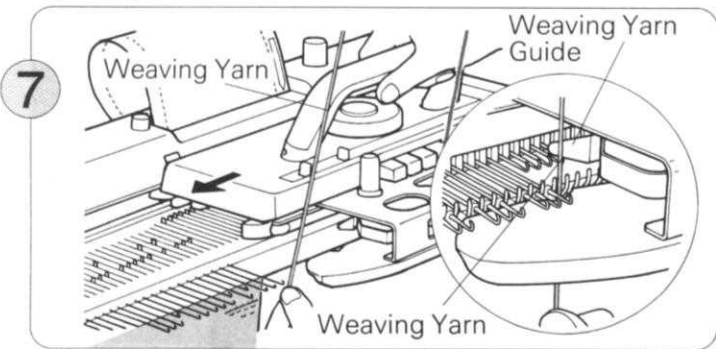

Hold the end of the weaving yarn with your lefthand, and thread it into the Weaving Yarn Guide on the left side of the K-Carriage. Then move the K-Carriage across the needlebed.

\*Release the yarn end after knitting one row.

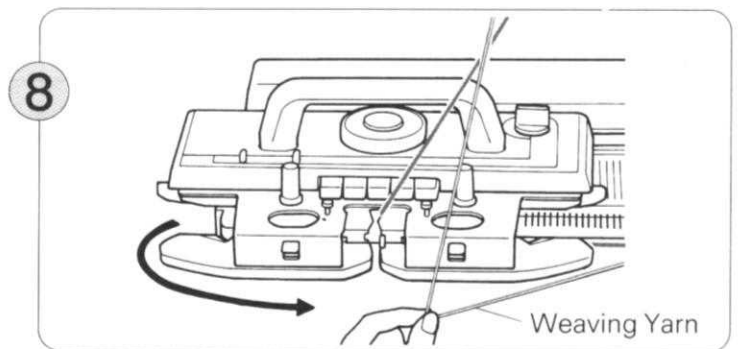

Remove the weaving yarn from the left Weaving Yarn Guide by moving the K-Carriage slightly to the left. Pass the weaving yarn under the K-Carriage to the righthand side.

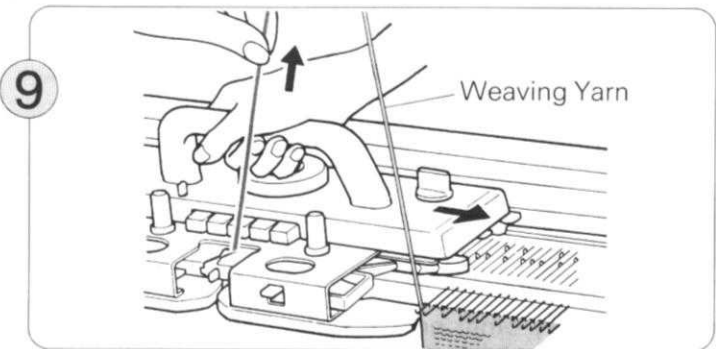

Move the K-Carriage to the right, pulling the main yarn upwards slightly – ensure that the weaving yarn is in the right Weaving Yarn Guide.

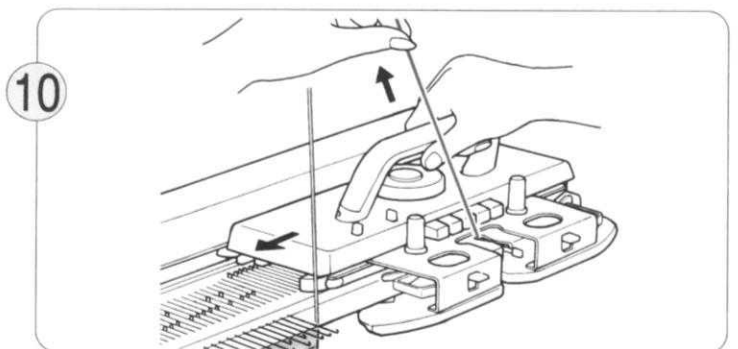

Continue knitting at the same time placing the weaving yarn into the left or right Weaving Yarn Guide according to the direction of the K-Carriage, and pulling the main yarn upwards slightly.

• To finish pattern knitting .....

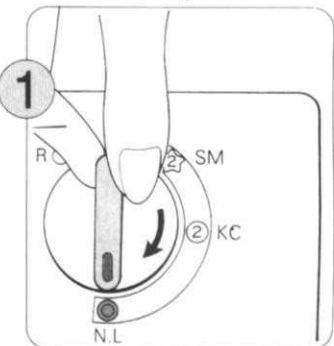

Set the Change Knob to N.L.

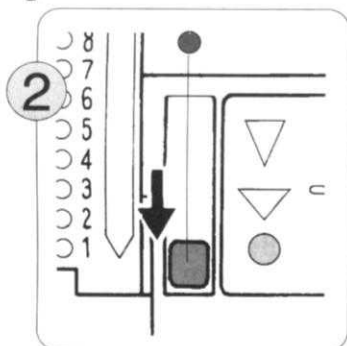

Set the Card Lock Lever at "●" mark.

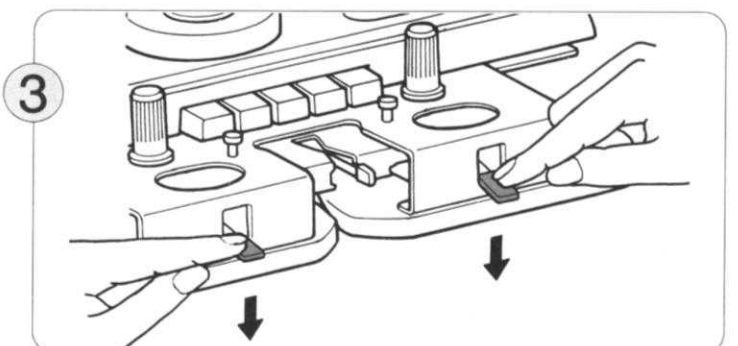

Set the Weaving Pattern Levers to N.

## WHEN USING MORE THAN TWO WEAVING YARNS ...

There are two ways to weave – one is to change the yarn in the Yarn Tension Unit, and the other is to lay the weaving yarn across the needles by hand.

### Second method ...

Lay the weaving yarn across the selected needles, beginning from the same side as the K-Carriage, as illustrated.

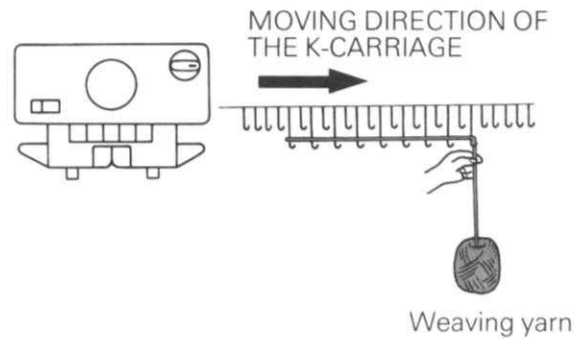
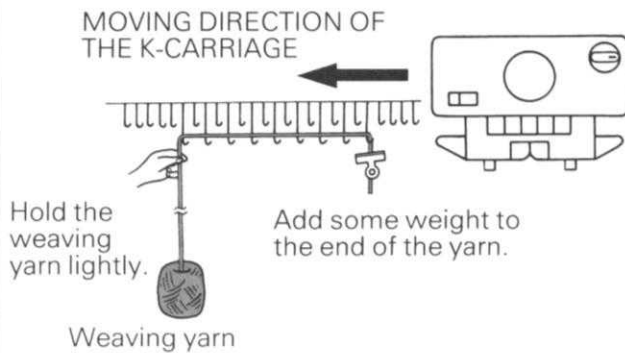

## 【WOVEN MOTIF PATTERN Card No. 1】

### Example: Card No. 1

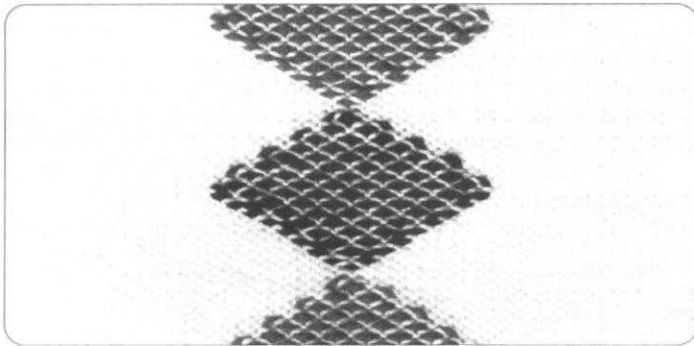

- Select every other needle using Card No. 1. Lay the yarn on the needles where you want the pattern to be.

Draw a diagram before you knit.  
Otherwise, use the Knit-leader.

- 1 Thread the main yarn into the righthand Yarn Tension Unit and place the weaving yarn on the floor at your feet. Follow steps ① – ⑥ on P.37.

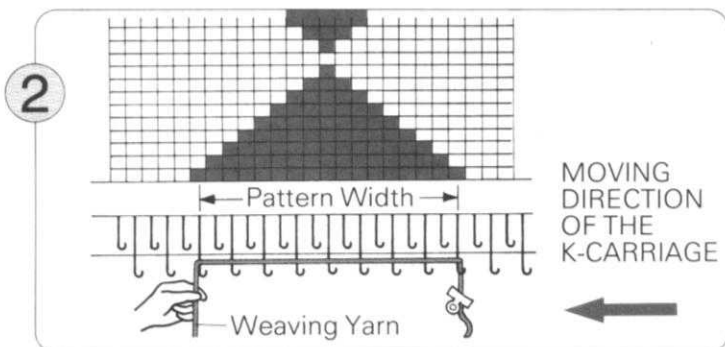

Lay the weaving yarn from the same side as the K-Carriage. Then operate the K-Carriage.

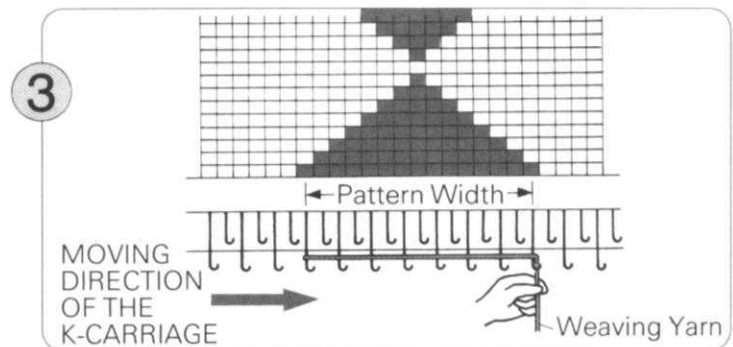

Continue to knit referring to the diagram.



# 【 FAIRISLE PATTERN Card No. 1,2,3,4,5,6,7,8,9,10,11,12,13,14,15,16 】

Example: Card No. 10

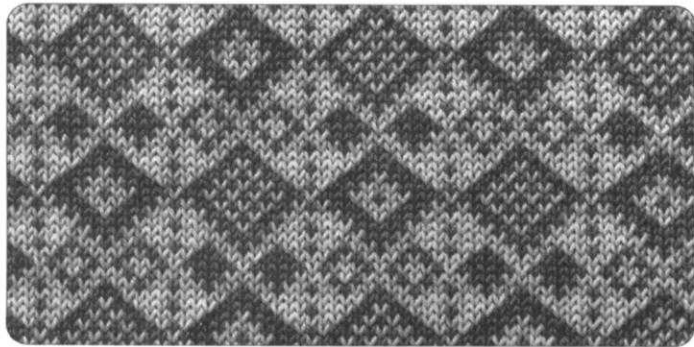

## ● THREADING THE YARN

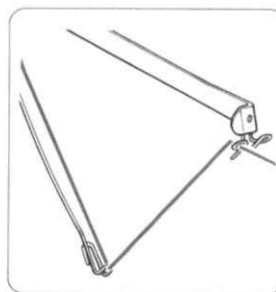

Thread the main yarn into the righthand Yarn Tension Unit, and the contrast yarn into the left Yarn Tension Unit, including the Sub Take-up Spring.

## ● PATTERN KNITTING

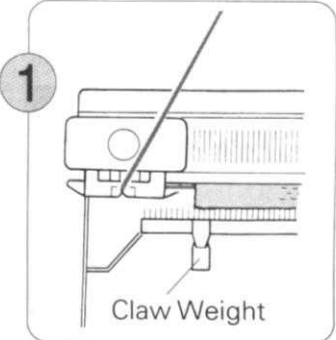

Knit a few rows in stocking stitch and place the K-Carriage on the left side of the machine. Hang the Claw Weights evenly along the Cast-on Comb.

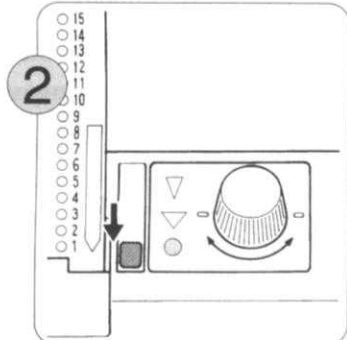

Insert the Punch Card and rotate it to Starting Line. Set the Card Lock Lever at "o" mark.

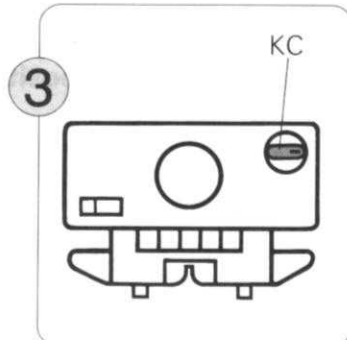

Set the Change Knob to KC.

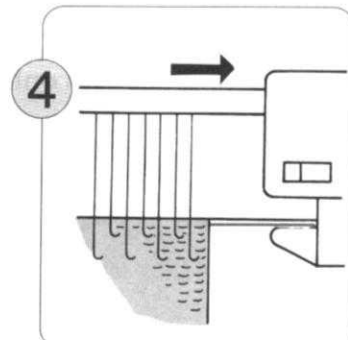

Move the K-Carriage from left to right. The needles are selected.

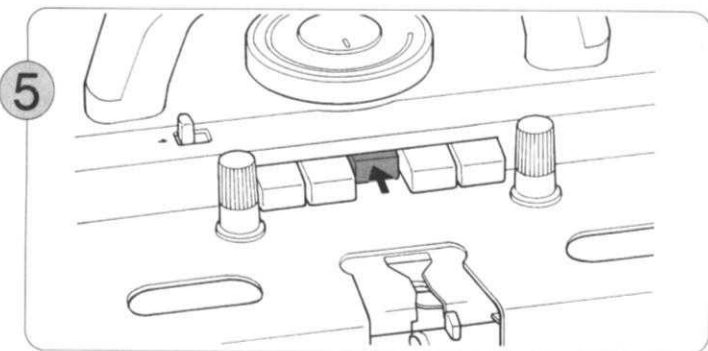

Push the MC Button.

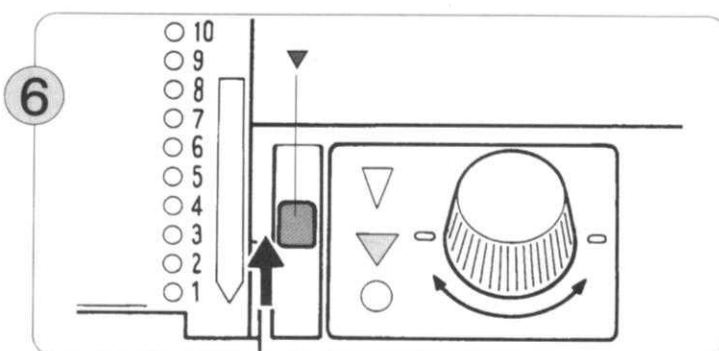

Set the Card Lock Lever at "v" mark.

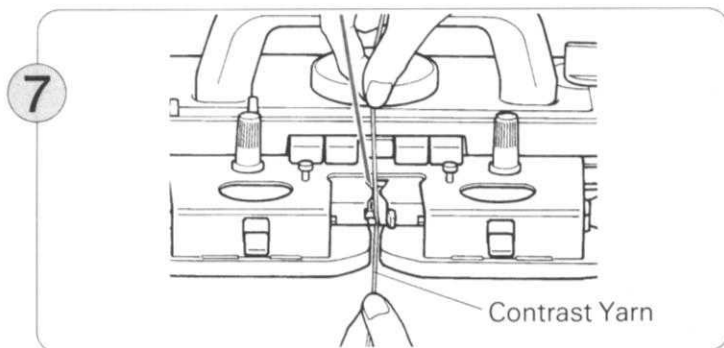

Thread the contrast yarn into Yarn Feeder "B" – there is no need to open the Yarn Feeder Lever when you do so.

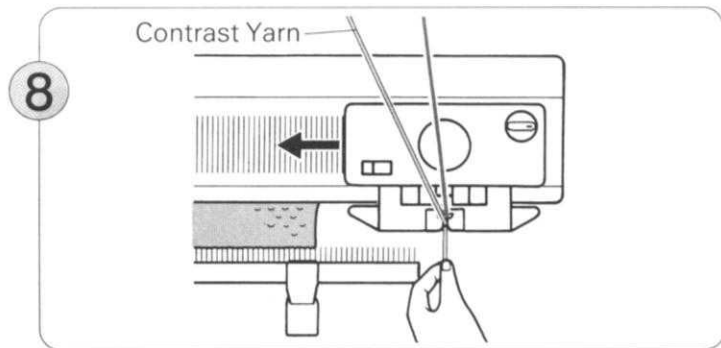

Holding the yarn end with your lefthand, move the K-Carriage from right to left.

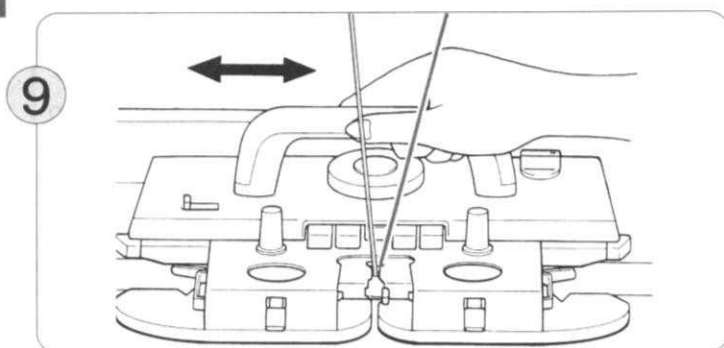

Move the K-Carriage back and forth. You are now knitting in Fairisle Pattern.

• To finish pattern knitting ....

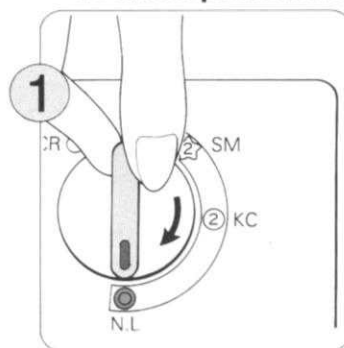

Set the Change Knob to N.L. The Cam Button will be released automatically.

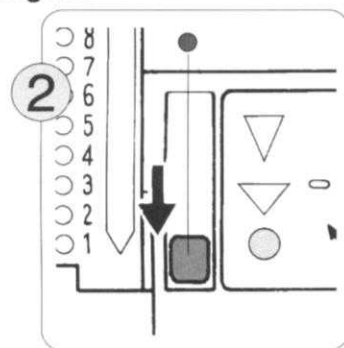

Set the Card Lock Lever at "•" mark. Take the contrast yarn out of Yarn Feeder B.

**When you knit rows using the main yarn only (i.e. no contrast colour) the end needles only will be selected to D position.**

When this happens, you should do the following:

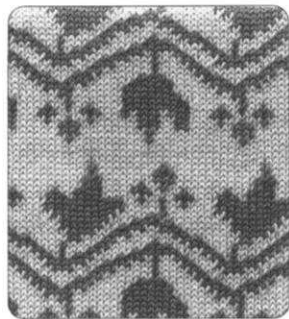

Card No. 6

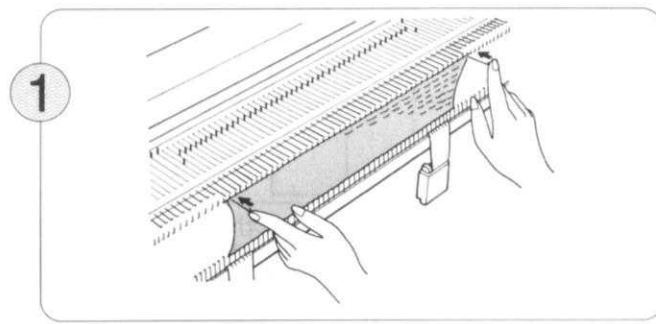

Bring the end needles back to B position.

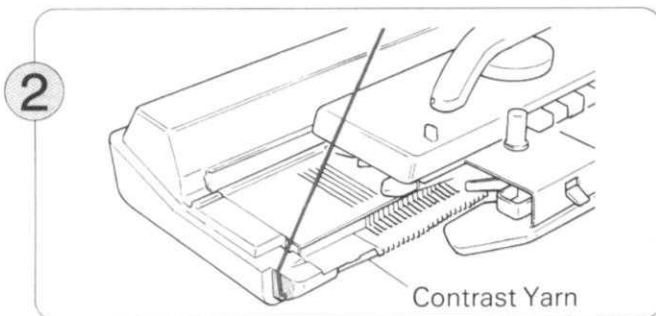

Take the contrast yarn out of Feeder "B" and hook it around the notch at the end of your machine. Then continue knitting with the main yarn only, bringing the end needles back to B position on each row.

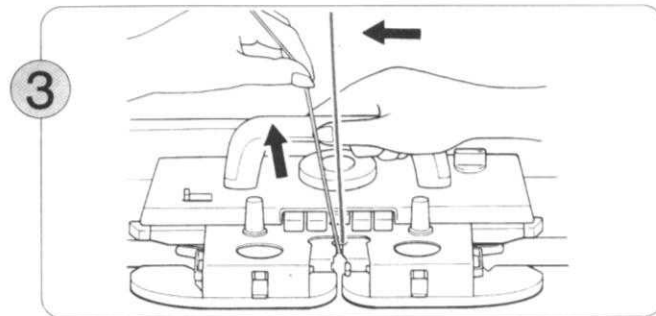

When the needles are selected across the row again for the pattern, rethread the contrast yarn into Feeder "B" and knit the row, holding the contrast yarn as shown so that no loops form at the edges.

## YARN CHANGING MARK



- Change the contrast yarn in Yarn Feeder "B" when the Yarn Changing Mark (asterisk) on the left side of the Punch Card comes to the card opening.
- ① Take the contrast yarn out of Yarn Feeder "B" and Yarn Tension Unit.
  - ② Thread the other contrast yarn into the Yarn Tension Unit and Yarn Feeder "B". Then continue knitting.

## 【 FAIRISLE MOTIF PATTERN Card No. 13 】

- When the Change Knob is set at SM, you can knit the pattern on the needles where you put the One-point Cam or Motif Knitting Cams.

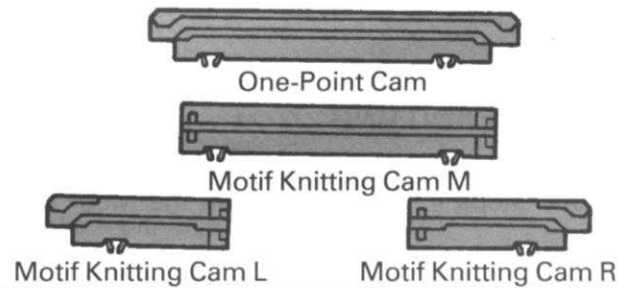

Ⓐ 24 needles width

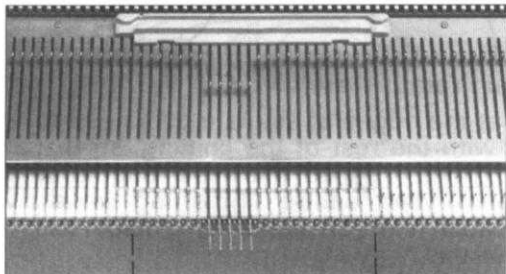

Ⓑ 48 needles width

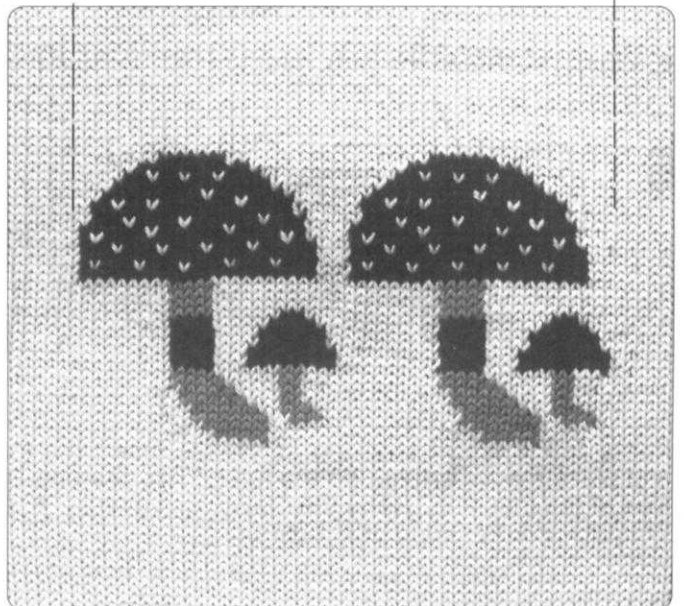
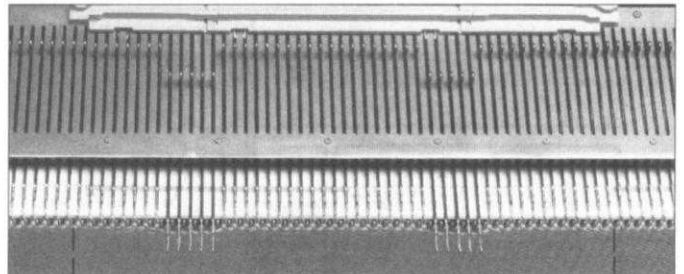



## ● HOW TO USE ONE-POINT CAM AND MOTIF KNITTING CAMS

The One-point Cam is used on its own.

The Motif Knitting Cams cannot be used individually. You must use them in sets.

When you join Motif Knitting Cams together, make sure the Cam at the righthand end is Cam R, and the one at the lefthand end is Cam L.

- 24 needles width



or



- 48 needles width



- 72 needles width



### CONNECT THE MOTIF KNITTING CAMS

Place the two ends of the Cams together, and push until you hear "click". To disconnect, pull both Cams apart.

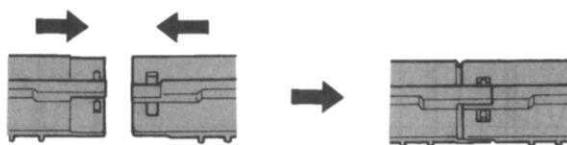

## ● PATTERN KNITTING

The following example uses the One-point Cam. Follow the same steps if you want to use the Motif Knitting Cams.

Prepare sufficient balls of yarn according to your punchcard pattern.

### Separate the main yarn in two.

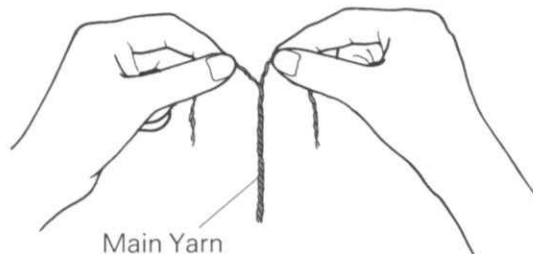

The stitches at the edges of single motifs need to be bound in with the rest of the knitting, so that there are no holes. To do this, use lengths of stranded main yarn called "finishing yarn". If you have a much finer yarn in the same colour it is possible to use this.

- When you thread the yarn, refer to P.40 "THREADING THE YARN".

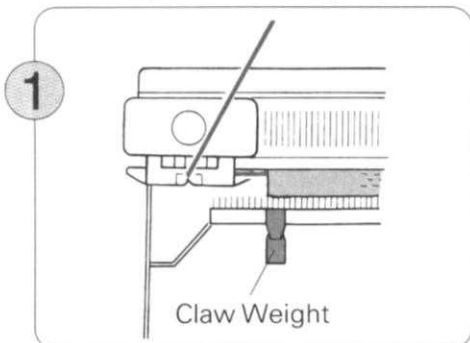

Knit a few rows in stocking stitch and place the K-Carriage on the left side of the machine. Hang the Claw Weights evenly along the Cast-on Comb.

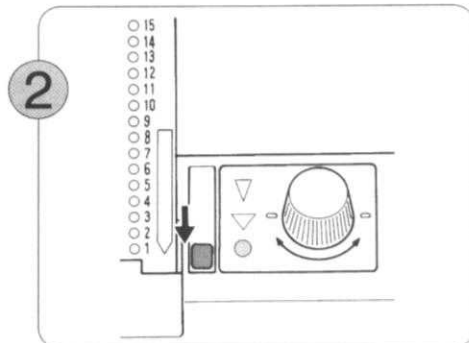

Insert the Punch Card and rotate it to Starting Line. Set the Card Lock Lever at "●" mark.

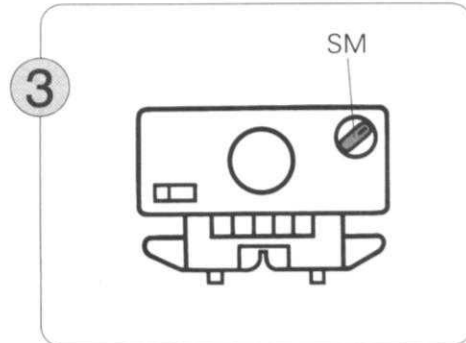

Set the Change Knob to SM.

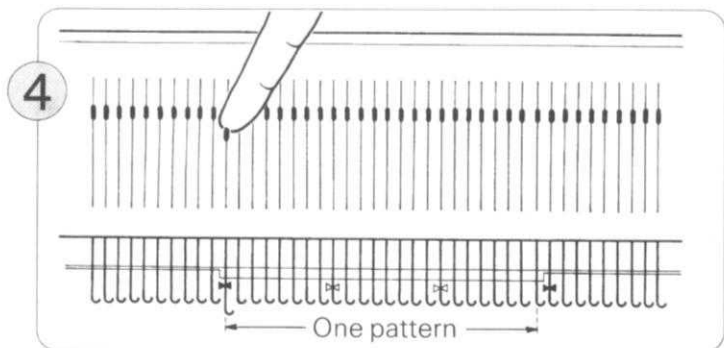

Decide where to place the One-point Cam, bearing in mind the needle selection (See P.29). \*If you bring the needles marked ►◄ forward a little, it's easy to match the ►◄ marks on the Needle Position Indicator and Cam.

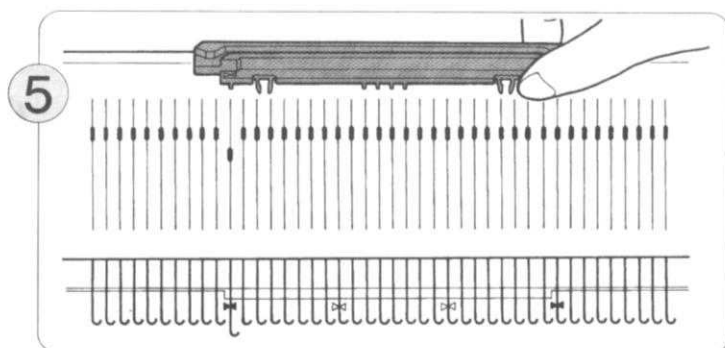

Place the One-point Cam on the needle bed by matching the ►◄ marks on the Needle Position Indicator and the Cam.

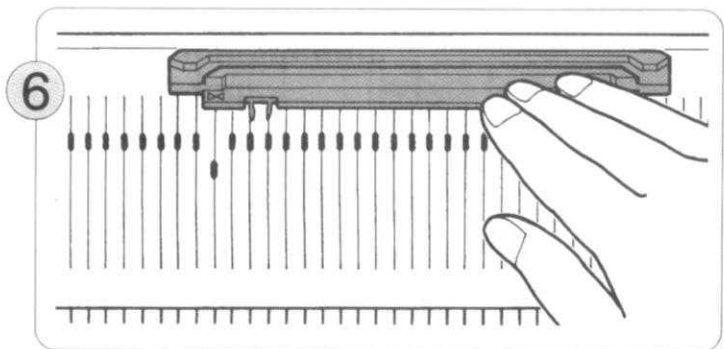

Push the Cam back as far as it will go, placing it in parallel with the Rear Rail. Make sure it is inserted correctly.

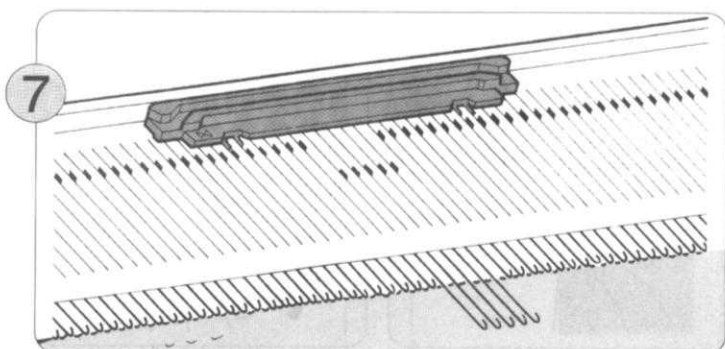

Move the K-Carriage from left to right. The needles corresponding to the One-point Cam are selected in pattern.

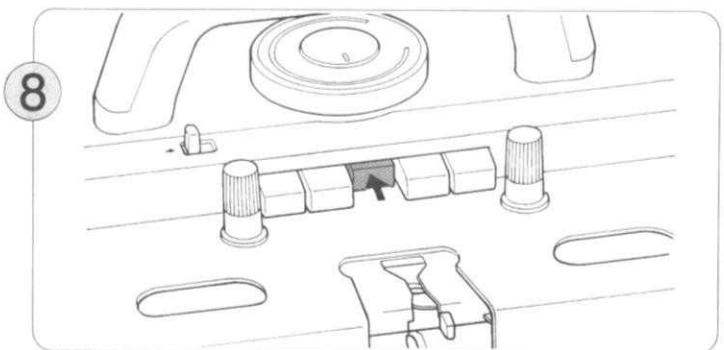

Push the MC button.

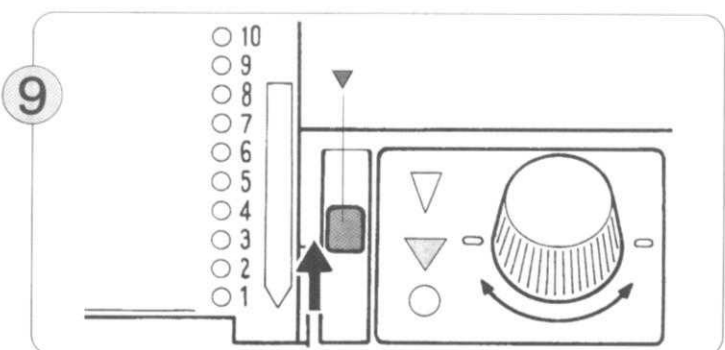

Set the Card Lock Lever at "▼" mark.

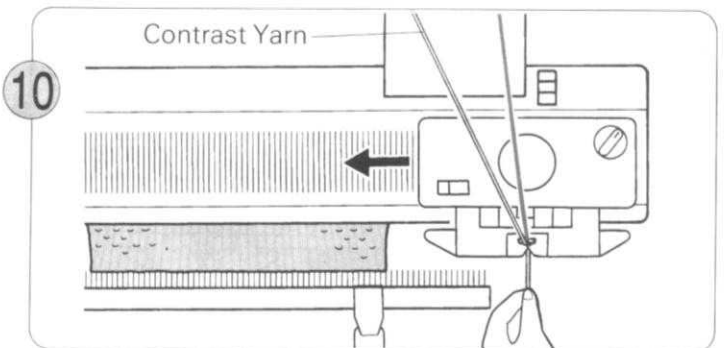

Thread the contrast yarn into Yarn Feeder "B" – there is no need to open the Yarn Feeder Lever when you do so. Move the K-Carriage from right to left holding the yarn end lightly.

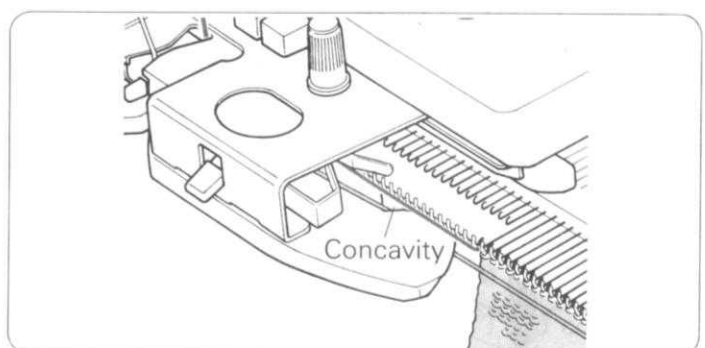

While knitting make sure the contrast yarn goes under the concavity in the Sinker Plate. Pull the yarn up slightly if there is any slackness.

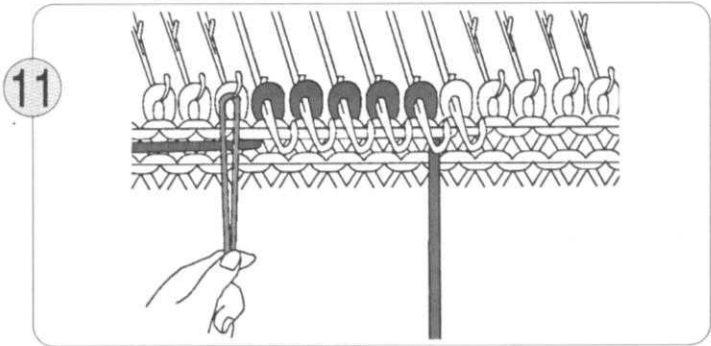

11 Fold the separate piece of finishing yarn in half and place it over the needle adjacent to the last selected needle at the left. Holding the end of the finishing yarn, move the K-Carriage to the right.

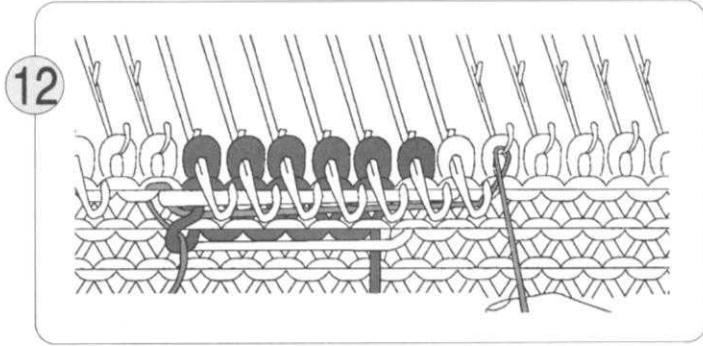

12 Take one end of the finishing yarn under the selected needles, and wrap it from right to left round the needle adjacent to the last selected needle on the right. (See illustration). Holding the end of the finishing yarn, move the K-Carriage from right to left.

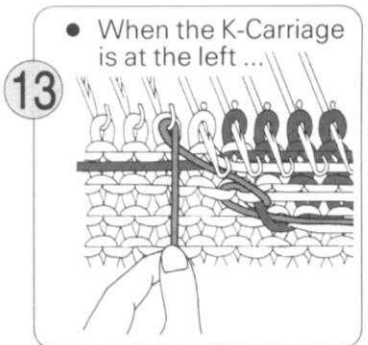

13 • When the K-Carriage is at the left ...  
• When the K-Carriage is at the right ...  
Wrap the finishing yarn around the hook of the needle adjacent to the first selected needle, and pull down gently.

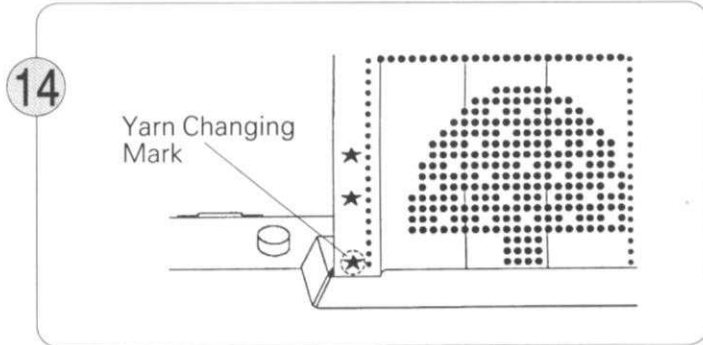

14 Change the contrast yarn in. Yarn Feeder "B" to the next one when the Yarn Changing Mark (asterisk) on the left side of the Punch Card comes to the card opening.

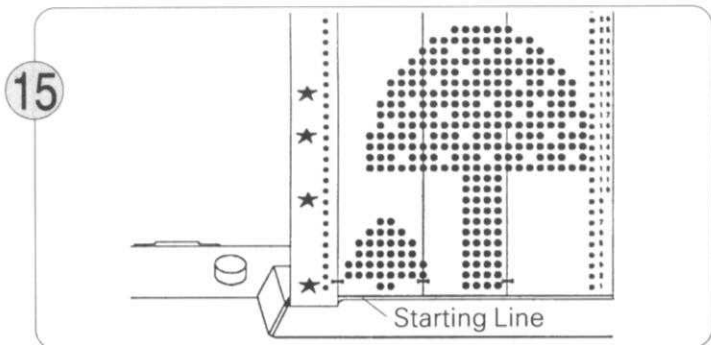

15 When the Starting Line appears in the card opening, one complete motif has been knitted.

• To finish pattern knitting ...

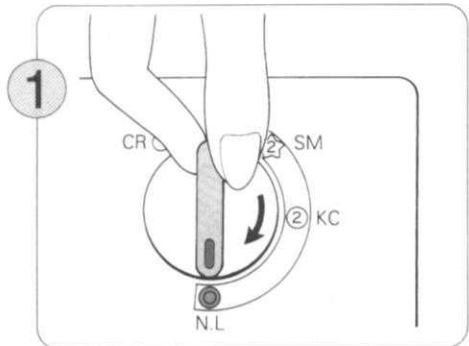

1 Set the Change Knob to N.L. The Cam Button will be automatically released.

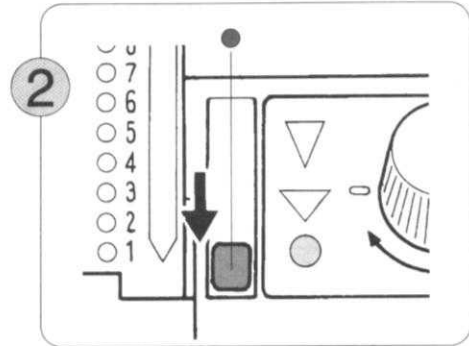

2 Set the Card Lock Lever at "•" mark. Take the contrast yarn out of Yarn Feeder "B".

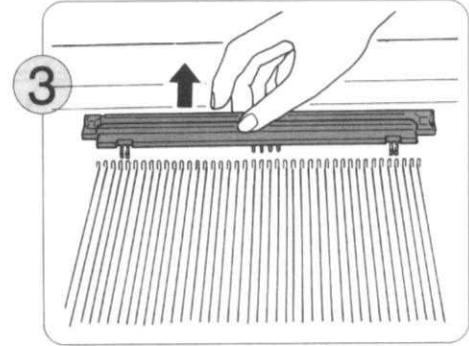

3 Remove the One-point Cam.



# 【 DOUBLE LENGTH PATTERN

Card No. 1,2,3,4,5,6,7,8,9,10,11,12,13,14,15,16】

• You can double the length of the pattern by setting the Card Lock Lever to "▽" mark.

♣ The Punch Card is rotated only when the K-Carriage moves from right to left when the Card Lock Lever is set at "▽" mark.

♣ This method is applicable to the Fairisle Pattern, Skip Stitch Pattern and Weaving Pattern.

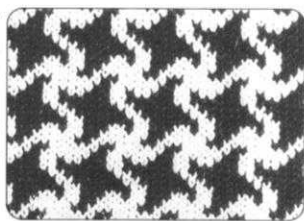

Card No. 4  
Normal Length Pattern



Double Length Pattern



Partially stretched to double length

## • PATTERN KNITTING

• When you thread the yarn, refer to P.40 "THREADING THE YARN"

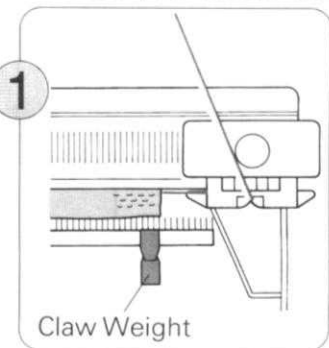

Claw Weight

Knit a few rows in stocking stitch and place the K-Carriage on the right side of the machine. Hang the Claw Weights evenly along the Cast-on Comb.

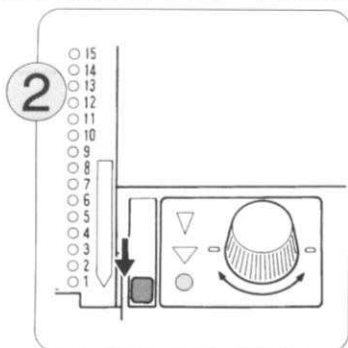

Insert the Punch Card and rotate it to Starting Line. Set the Card Lock Lever at "●" mark.

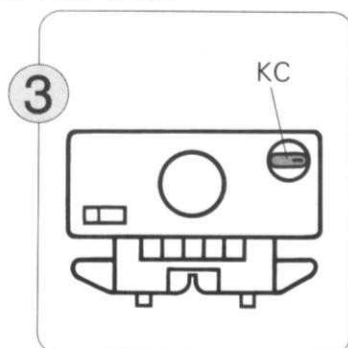

Set the Change Knob to KC.

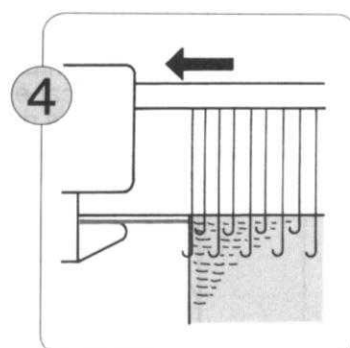

Move the K-Carriage from right to left. The needles are selected.

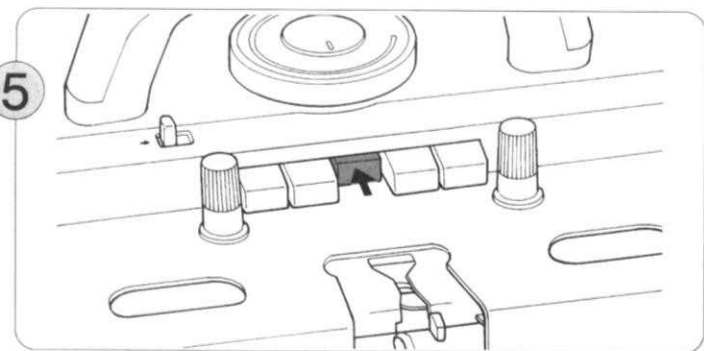

Push the MC Button.

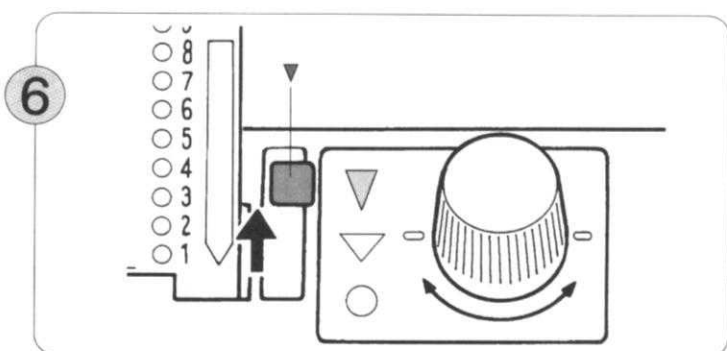

Set the Card Lock Lever at "▽" mark.

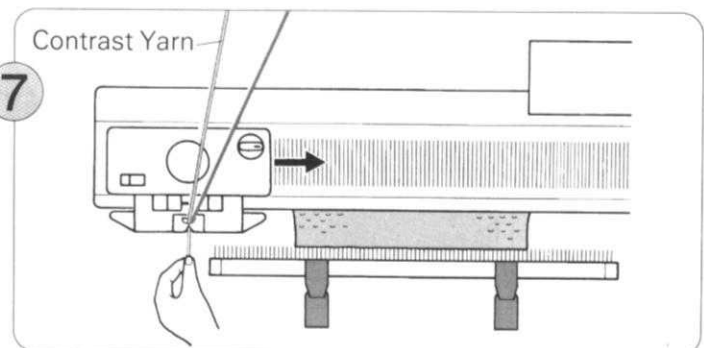

Holding the yarn end with your lefthand, move the K-Carriage from left to right. Continue knitting.

### When knitting Normal and Double Length Patterns Mixed

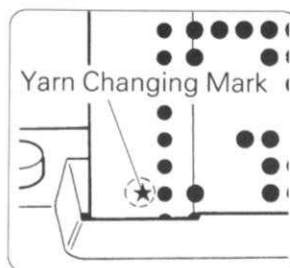

• When the Yarn Changing Mark (asterisk) on the leftside of the Punch Card comes to the card opening change the setting of the Card Lock Lever ("▽" or "▽") and continue knitting.

Always ensure that the K-Carriage is at left when changing Card Lock Lever.

# [ LACE PATTERN AND FINE LACE PATTERN

Lace Pattern: Card No.17,18,19,20, Fine Lace Pattern: Card No. 17,19,20]

## LACE PATTERN

Card No. 20

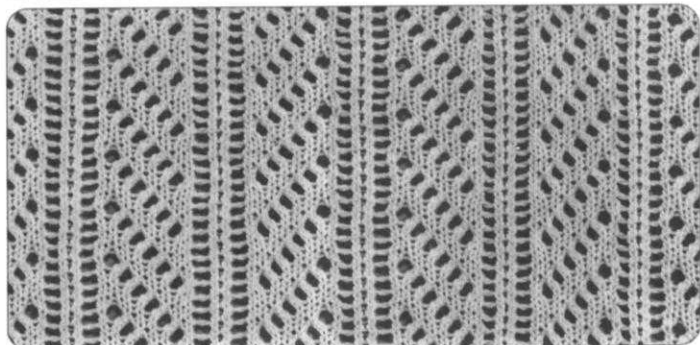

## FINE LACE PATTERN

Card No. 20

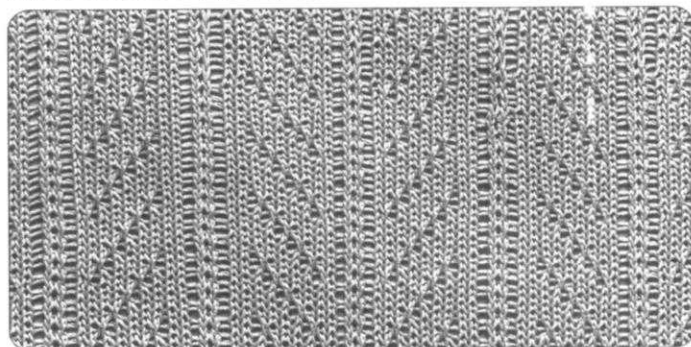

You must use the Lace Carriage (L-Carriage) for Lace or Fine Lace Pattern. The methods for knitting next Lace and Fine Lace Patterns are identical except the setting of the Lace Change Lever is different.

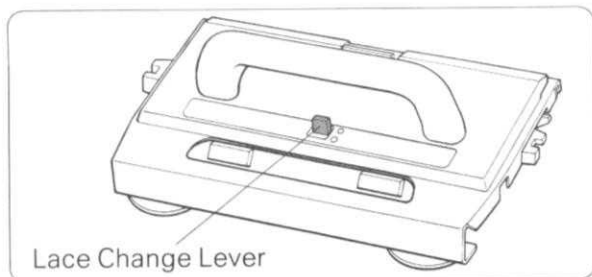

### APPROXIMATE TENSION CHART

Very fine yarn	4-5
Fine yarn	4-5
Medium yarn	5-6

### • HOW TO SET THE L-CARRIAGE

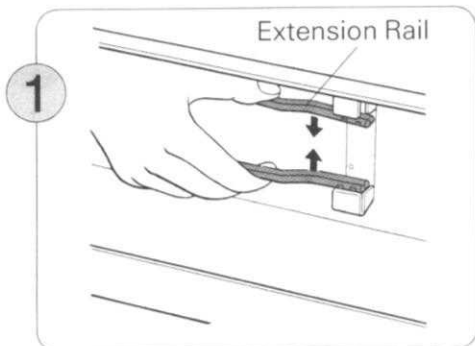

Remove the Extension Rails from the Carrying Case.

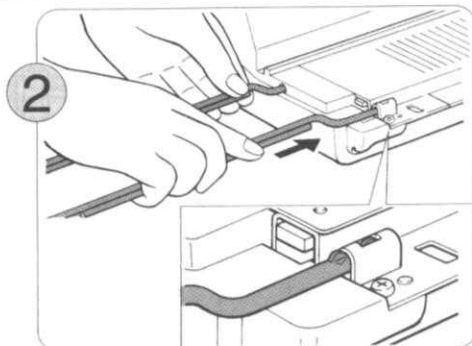

Insert the Extension Rails securely into the holes at both sides of the machine.

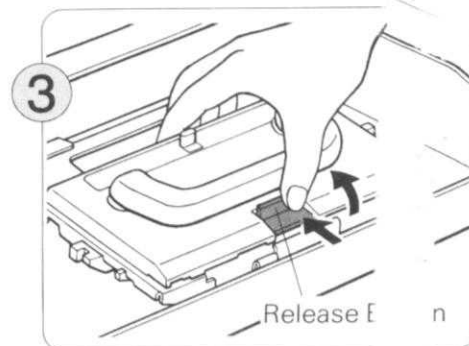

Remove the L-Carriage by the Release Button.

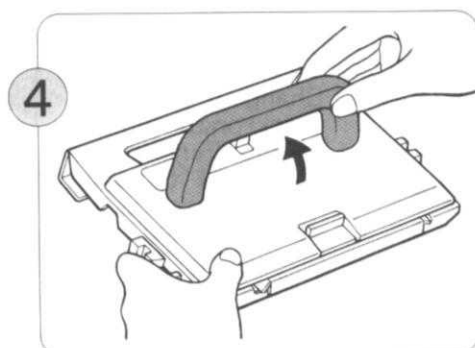

Raise the L-Carriage Handle.

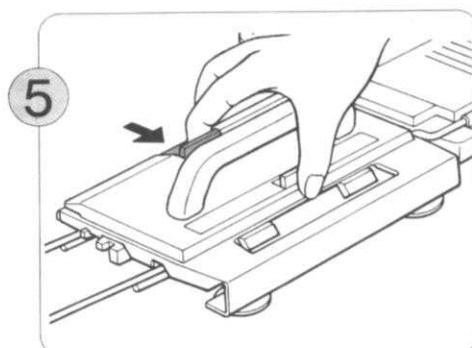

Push the Release Button and place the L-Carriage securely on the left Extension Rail.

● PATTERN KNITTING

1



Thread the main yarn into the righthand Yarn Tension Unit.

2

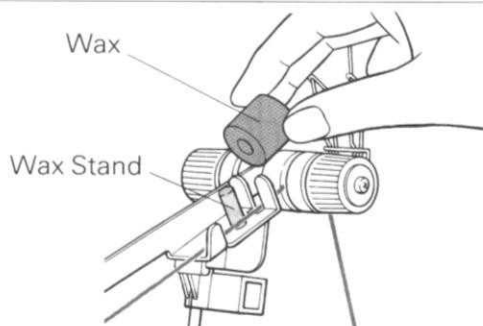

Take the Wax out of the Wax Case and place it on the Wax Stand.

♣ You need to use the Wax when you are knitting Lace or Fine Lace Patterns.

3

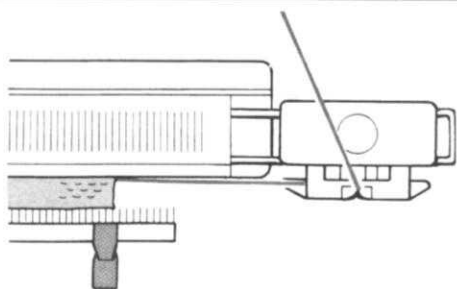

Knit a few rows in stocking stitch and place the K-Carriage on the right Extension Rail.

Hang the Claw Weights evenly along the Cast-on Comb.

4

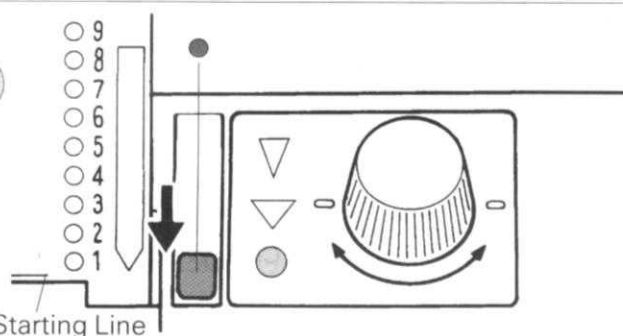

Insert the Punch Card and rotate it to Starting Line. Set the Card Lock Lever at "●" mark.

5

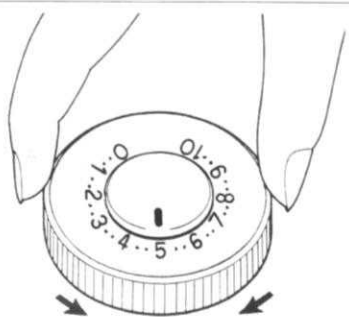

Set the Tension Dial according to the yarn you are using. (Refer to the Approximate Tension Chart on P.47).

6

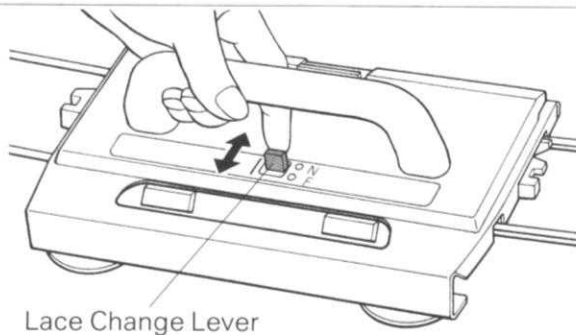

Set the Lace Change Lever to either N or F according to the pattern you are going to knit.

N - Normal Lace Pattern    F - Fine Lace Pattern

7

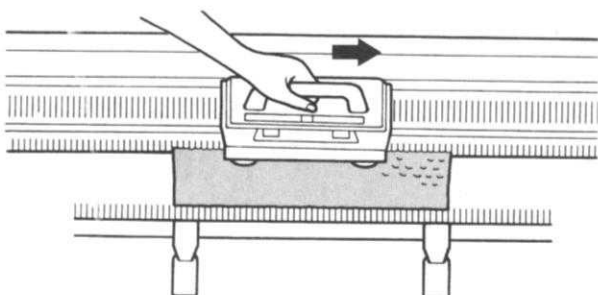

Move the L-Carriage to the right slowly. The needles are selected.

8

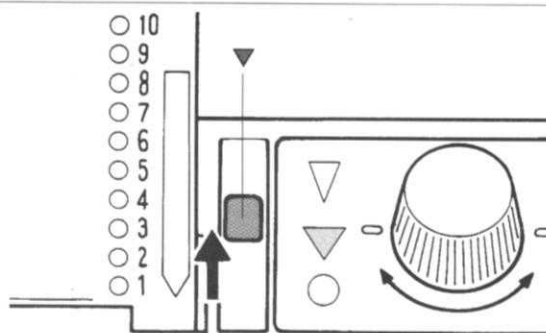



Set the Card Lock Lever at "▼" mark.

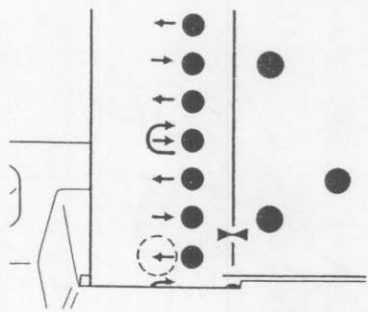

9



-  ... Knit two rows with the K-Carriage, then move the L-Carriage from left to right.
-  ... Operate the L-Carriage from left to right.
-  ... Operate the L-Carriage from right to left.

Use either the L-Carriage or the K-Carriage according to the mark on the left side of the Punch Card.

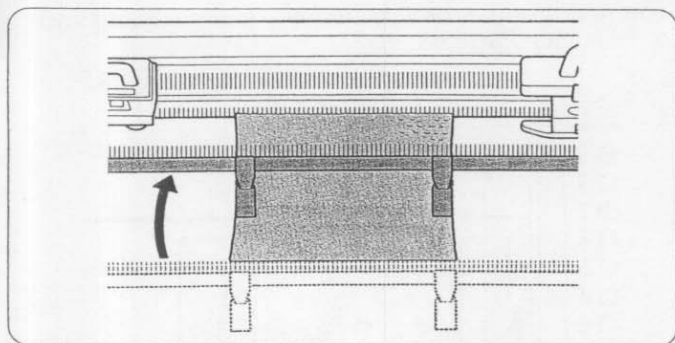

Rehang the Cast-on Comb and Claw Weights if the knitting becomes too long.

• To finish pattern knitting ...

1

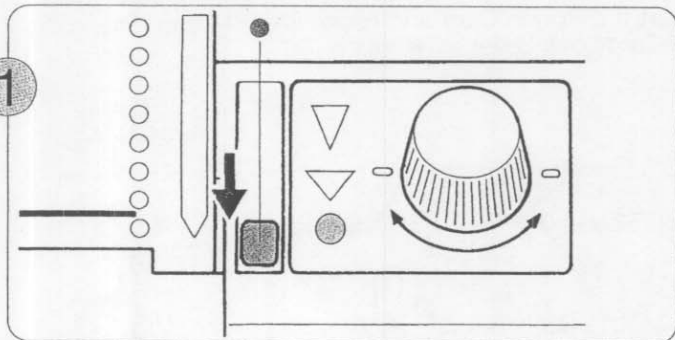

Set the Card Lock Lever at "●" mark.

10

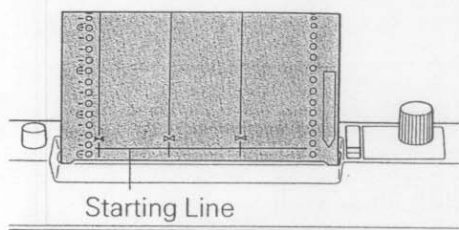

When the last  mark below the Starting Line comes to the card opening, one Lace Pattern Card has been completed.

2

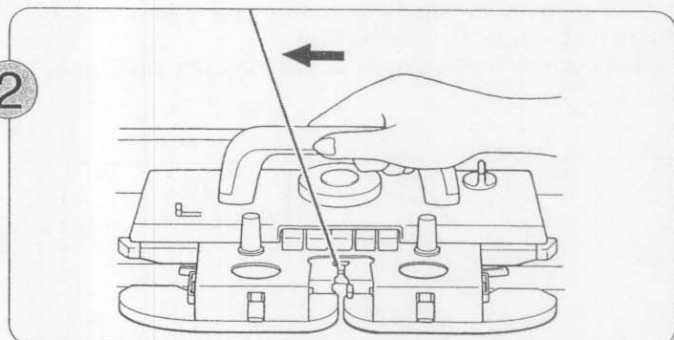

Knit as many rows as you wish in stocking stitch.

NOTE

When you design your own Punch Cards for Lace or Fine Lace Pattern, ensure that two needles next to each other are not selected.

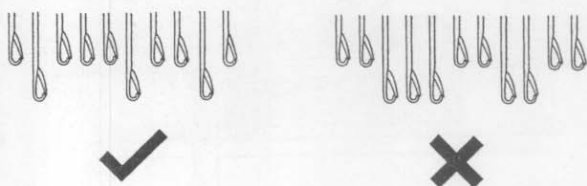

# [ LACE AND FINE LACE MIXED Card No. 19 ]

- By changing the setting of the Lace Change Lever on the L-Carriage according to the arrows (→ and →) on the Punch Card, you can knit a mixture of Lace and Fine Lace.

You can decide yourself which arrow represents which type of pattern, i.e:

→ ....N    → ....F  
 → ....N    → ....F

- Your patterns will be different depending on your choice.

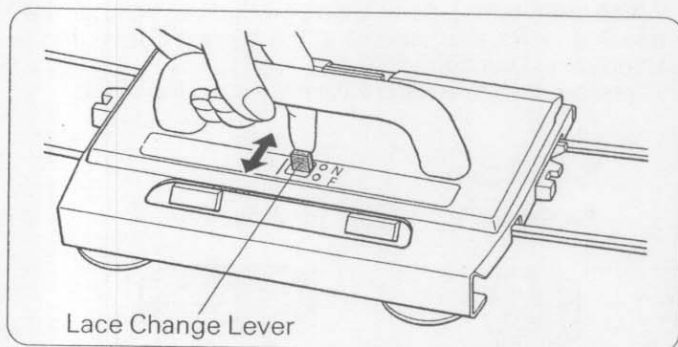

## • PATTERN KNITTING

- 1 Follow steps ①-⑤ on P.48.
- 2 First decide which mark (→ or →) corresponds to N or F of Lace Change Lever.
- 3 Continue knitting according to the marks on the left side of the Punch Card. (Refer to steps ⑥ - ⑩ on P.48).

- Example A → :N, → :F

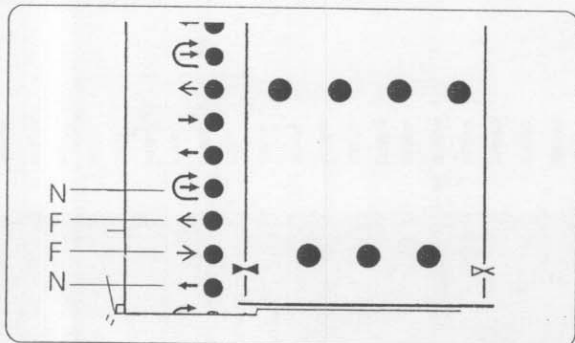

- Example B → :N → :F

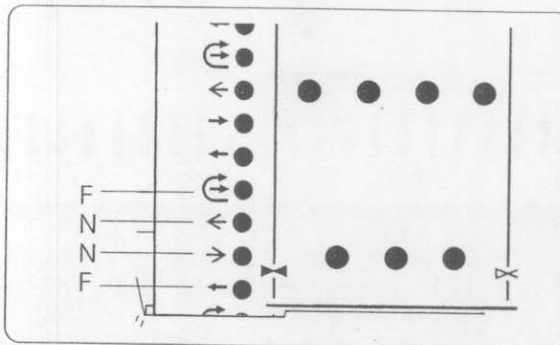

Card No. 19

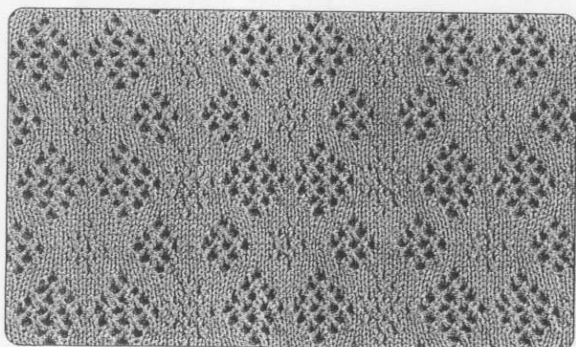

Card No. 19

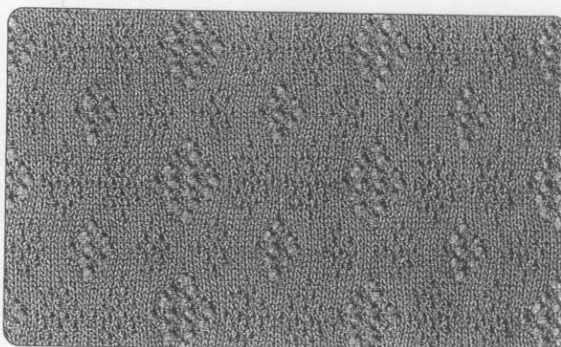

# [ ISOLATED LACE PATTERN Card No. 17,18,19,20 ]

- When you fit the L-point Cams on the needle bed, the needles which correspond to the L-point Cams aren't selected to D position. Therefore these needles will knit in stocking stitch.

L-point Cam  
for 4-needle



for 8-needle

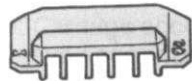

Card No. 20 When not using L-point Cam

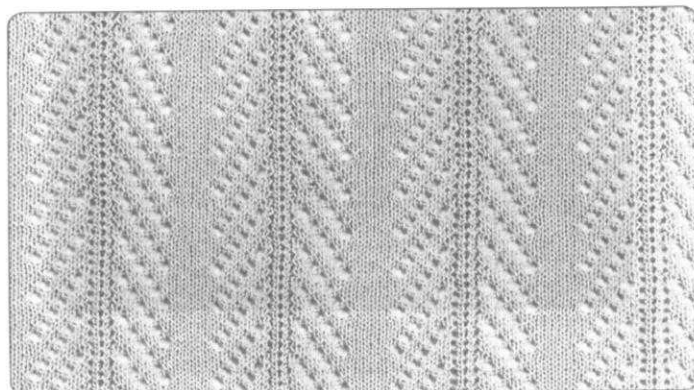
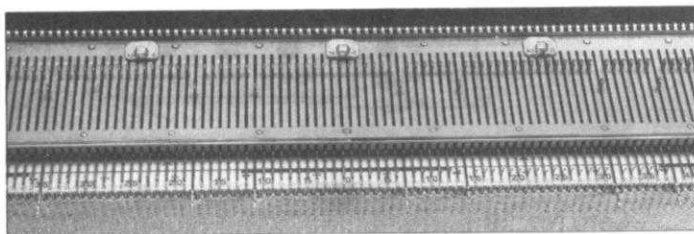
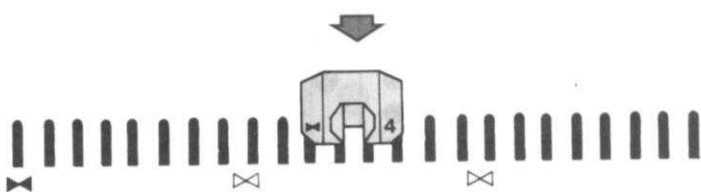
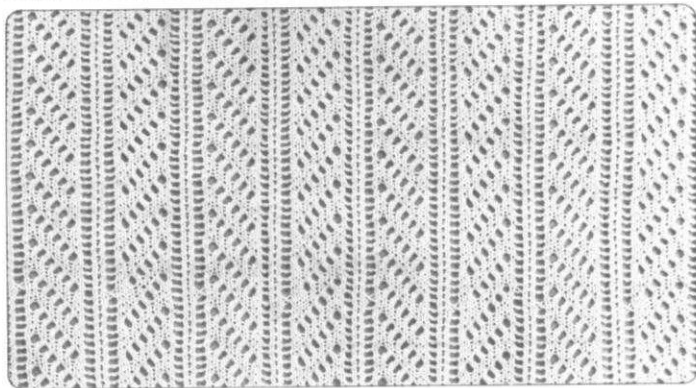

(A)

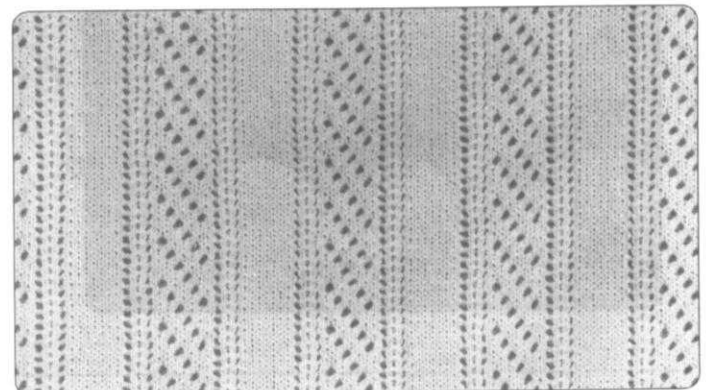
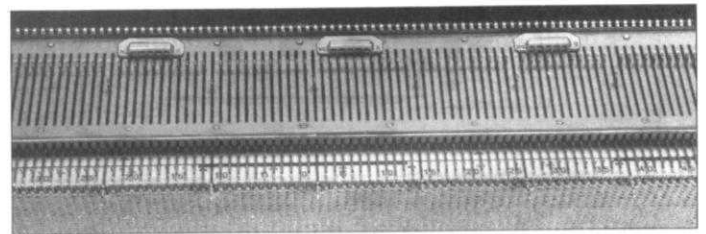
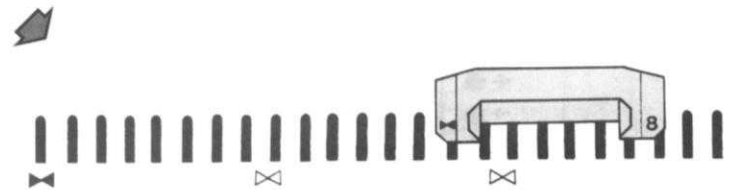

(B)

## Setting of the L-point Cam

- ♣ You can combine as many L-point Cams as you want according to the width of stocking stitch on your design.

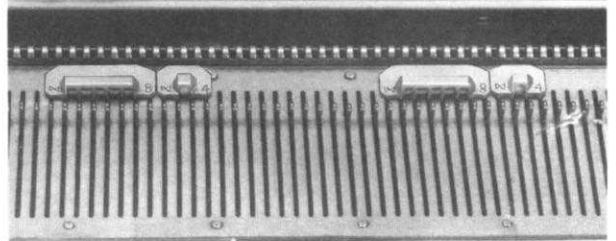

- ♣ The L-point Cams cannot be used for Fairisle Motif Pattern. Remove the L-point Cams after finishing the Isolated Lace Pattern.

● **PATTERN KNITTING** This example uses the 4-needle L-point Cam.

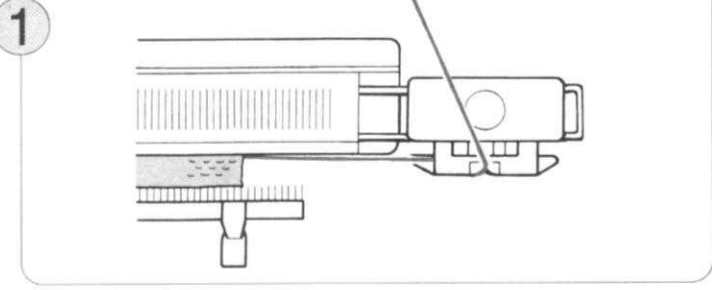

Follow the steps ①-③ on P.48.

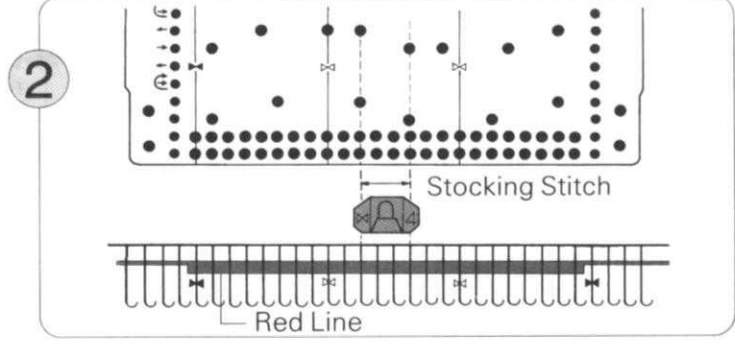

Decide the position where you want to knit in stocking stitch.

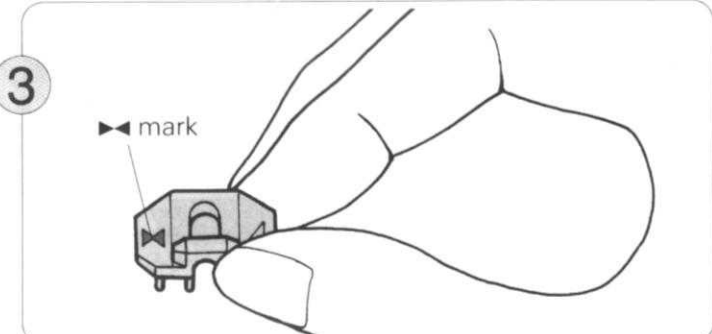

Hold the L-point Cam with the pegs pointing downwards and the  $\blacktriangleleft$  mark on the lefthand side as shown.

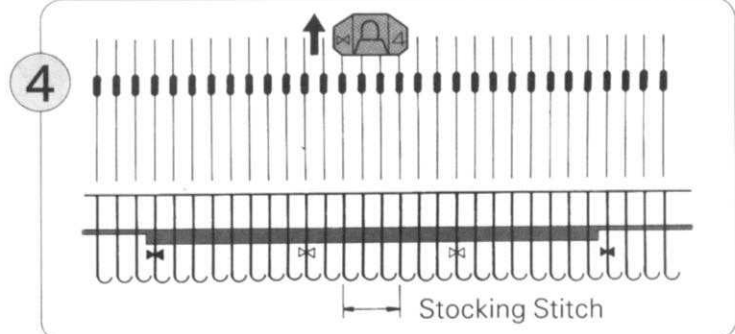

Place the  $\blacktriangleleft$  mark on the L-point Cam over the left end needle which you want to knit stocking stitch, and insert the pegs into the grooves in the needle bed.

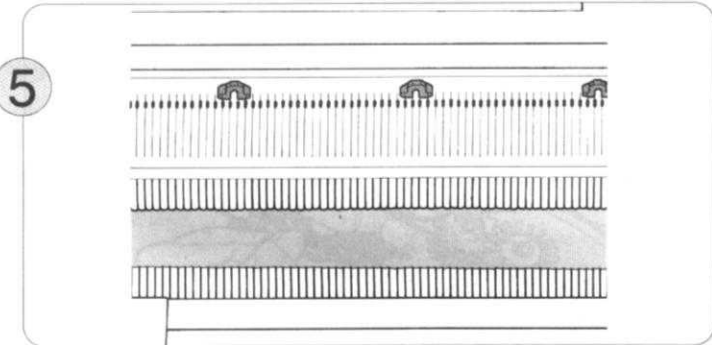

Place other L-point Cams wherever else you want to knit in stocking stitch.

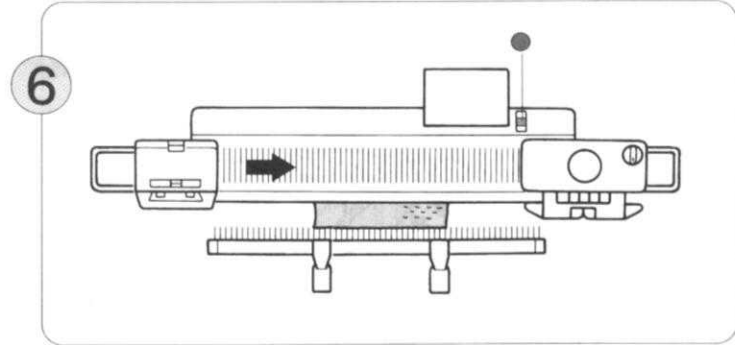

Follow steps ④ - ⑩ on P.48.

**NOTE**

Move the L-Carriage slowly while the L-point Cams are being used.



# 【 PLATING 】

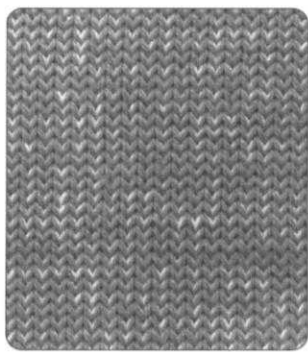

Front (Plain)

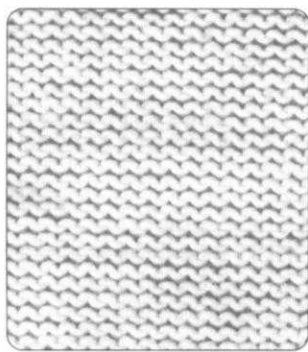

Reverse (Purl)

- With the Plating Yarn Feeder, you can use two yarns to knit a reversible fabric, with one colour on the right side and the other on the wrong side. The main yarn will be on the front (plain) side of the knitting and the plating yarn will be on the reverse (purl) side.

## Plating Yarn Feeder

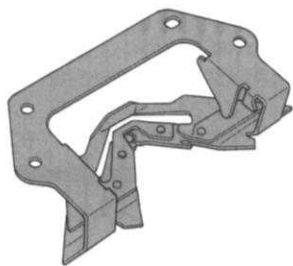

## APPROXIMATE TENSION CHART

YARN		TENSION DIAL
Very fine	Very fine	4-5
Fine	Very fine	6-7
Fine	Fine	8-9

- The setting for the K-Carriage is the same as for stocking stitch. Prepare your two yarns – use fine or very fine yarn.

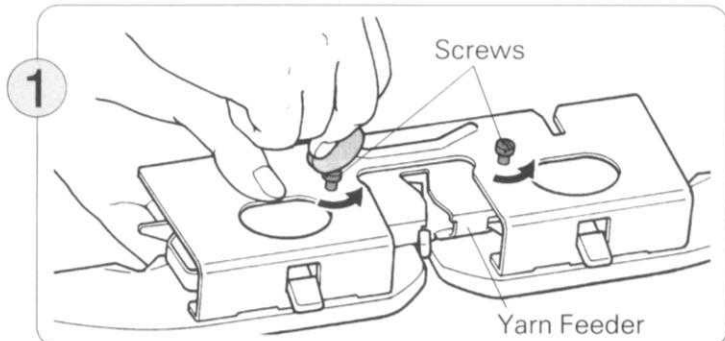

Remove the two screws and the Yarn Feeder from the Sinkers Plate Assembly.

- ♣ Be sure to keep the screws safely.

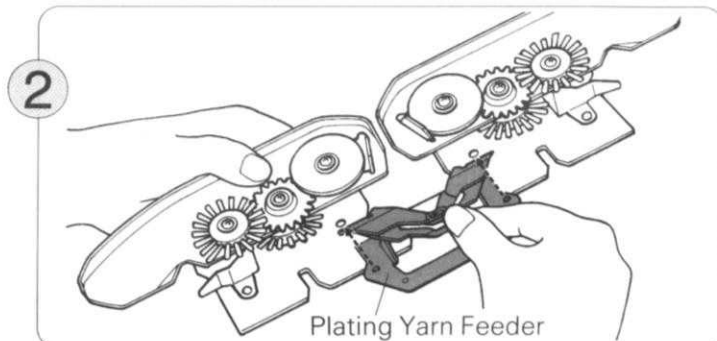

Take the Plating Yarn Feeder out of the Accessory Box and fit it into the Sinkers Plate Assembly as shown above.

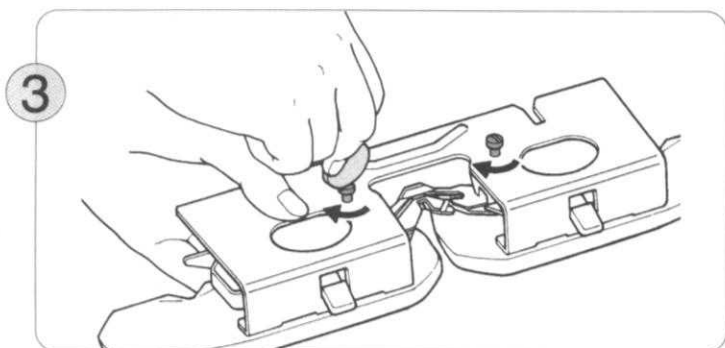

Fasten the two screws.

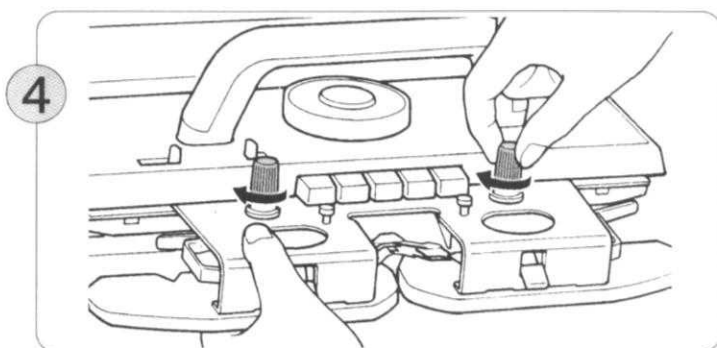

After you have changed the Yarn Feeder, screw the Sinkers Plate Assembly back on the K-Carriage.

5

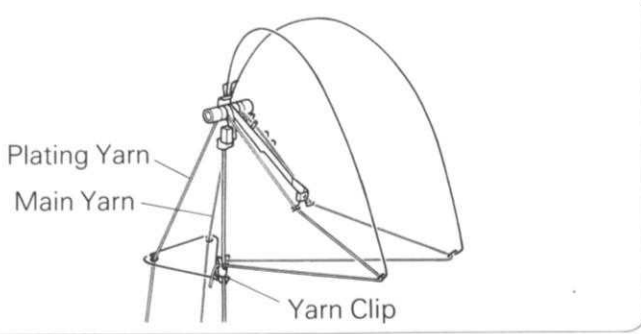

Thread the yarns into the Yarn Tension Unit as shown.

6

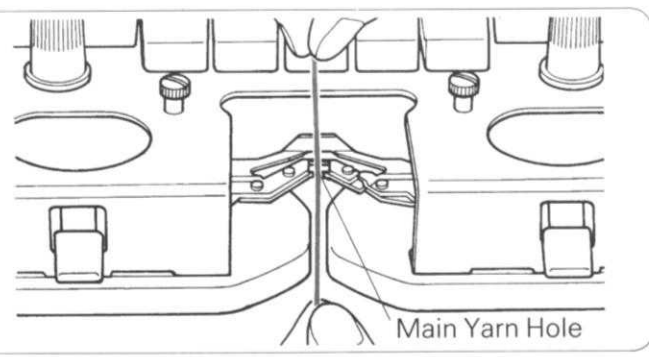

Thread the main yarn into the Main Yarn Hole.

7

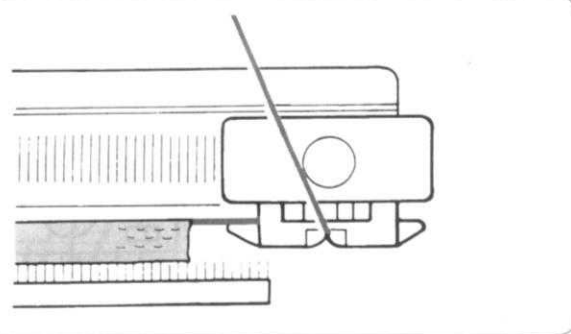

Knit a few rows in stocking stitch, ending with the K-Carriage on the right of the machine.

8

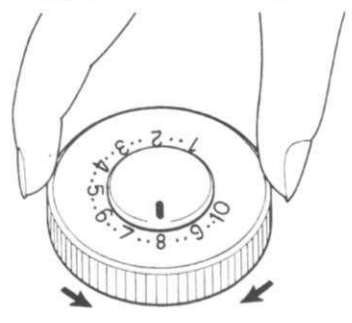

Set the Tension Dial according to the yarn you are using. Refer to the Approximate Tension Chart on P.53.

9

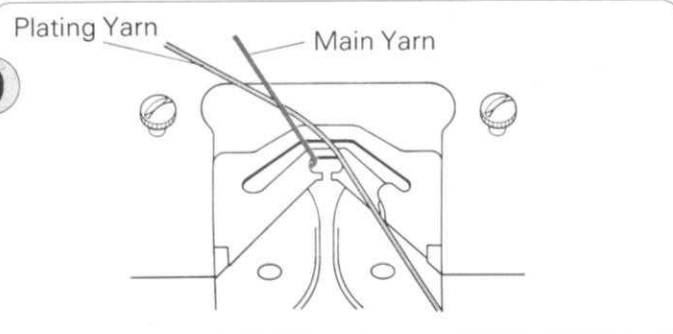

Pass the end of the plating yarn behind the main yarn.

10

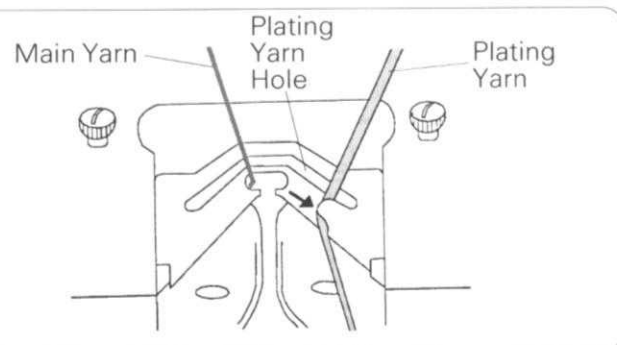

Now thread the Plating yarn into the Plating Yarn Hole. There is an opening at the side and you can pass the yarn through this slit.

11

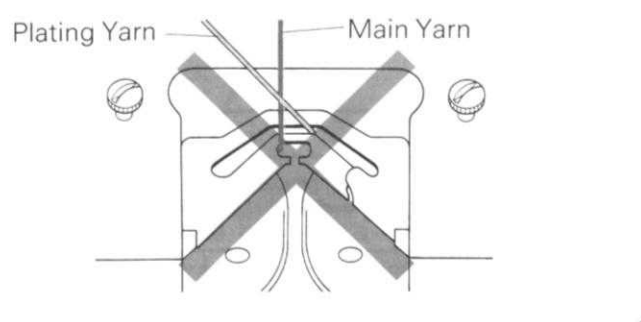

Make sure the two yarns are not crossed.

11

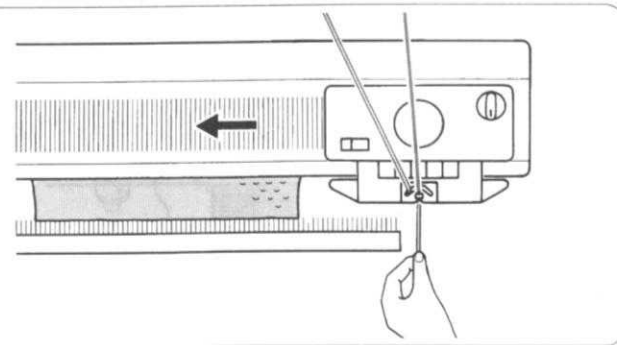

Hold the end of the plating yarn with your lefthand, and move the K-Carriage to the left. Once the needles have caught the yarn, you can release the yarn end. Continue knitting in this way. You are now knitting plating.

# [ CHANGING THE MAIN YARN AND THE PLATING YARN ]

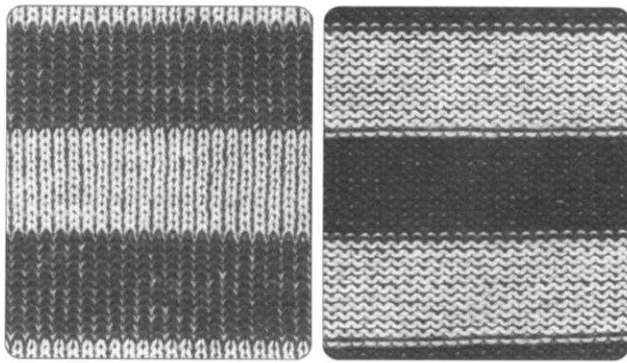

Front (Plain)

Reverse (Purl)

- This is knitted the same as ordinary Plating, except the yarns are changed.

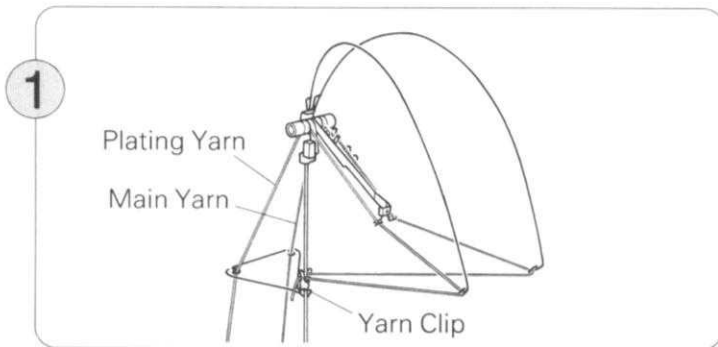

Thread the yarns into the Yarn Tension Unit as shown.

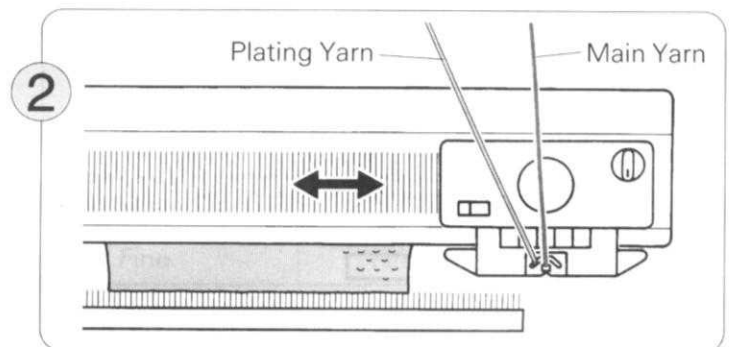

Follow the Steps given for Plating and continue knitting until you want to change the yarn. (See P.53-54).

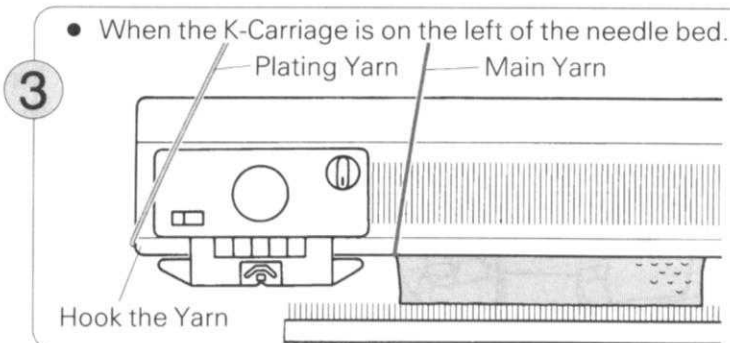

- When the K-Carriage is on the left of the needle bed.

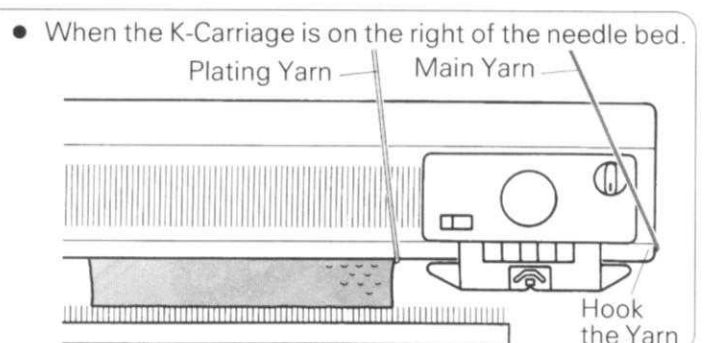

- When the K-Carriage is on the right of the needle bed.

To change the yarn, do as follows:

- ① Take the yarn out of the Main Yarn Hole.
- ② Take the yarn out of the Plating Yarn Hole.
- ♣ Hook the yarn in the right Yarn Tension Unit into the righthand notch.
- ♣ Hook the yarn in the left Yarn Tension Unit into the lefthand notch.

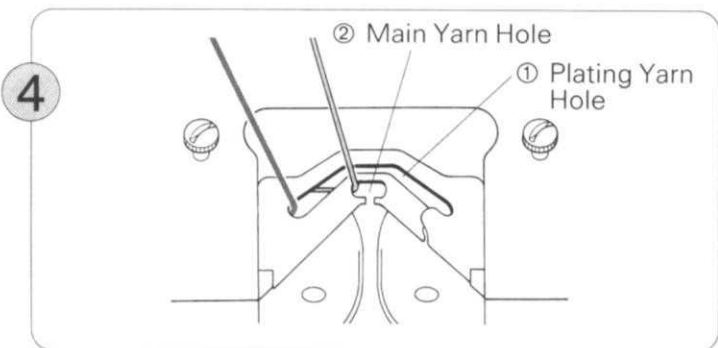

- ① Thread up the Plating Yarn Hole.
- ② Thread up the Main Yarn Hole.

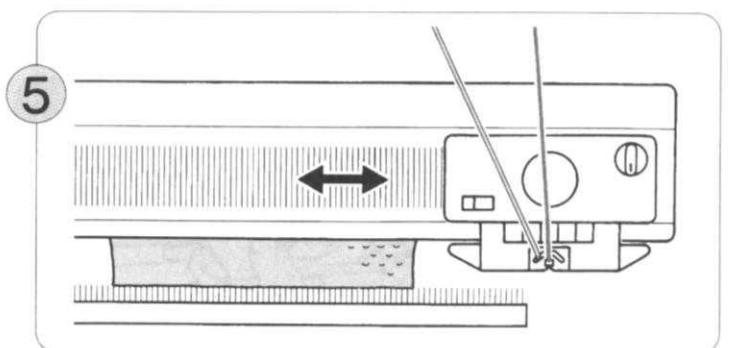

Continue knitting, changing the yarn when you wish.

# [ PLATED TUCK STITCH PATTERN Card No. 1,3,8 ]

## Example: Card No. 3

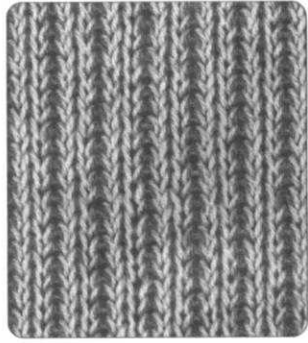

Front (Plain)

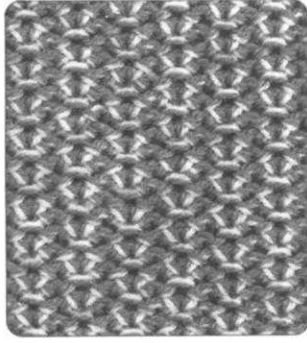

Reverse (Purl)

- This is knitted the same as Tuck Stitch Pattern, using the Plating Yarn Feeder.

## • PATTERN KNITTING

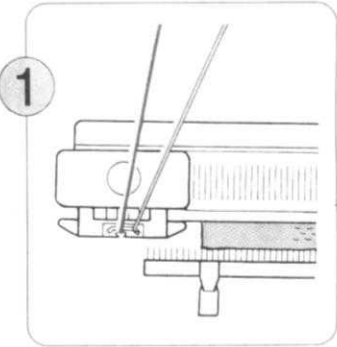

Knit a few rows in plating and place the K-Carriage on the left side of the machine. Hang the Claw Weights evenly along the Cast-on Comb. (Refer to P.53-54).

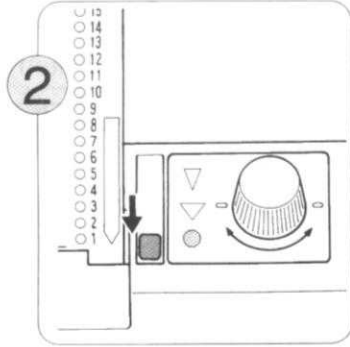

Insert the Punch Card and rotate it to Starting Line. Set the Card Lock Lever at "o" mark.

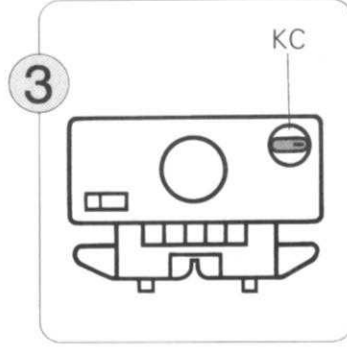

Set the Change Knob to KC.

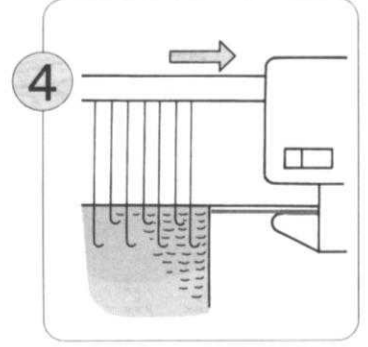

Move the K-Carriage from left to right. The needles are selected.

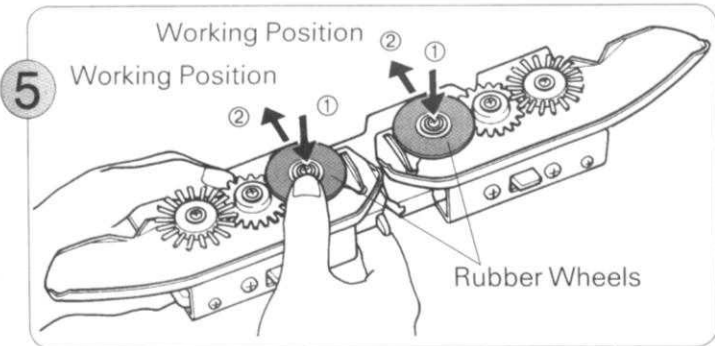

Remove the Sinker Plate Assembly from the K-Carriage and turn it over; Put the Rubber Wheels into working position ② as shown. Attach the Sinker Plate Assembly back on the K-Carriage again.

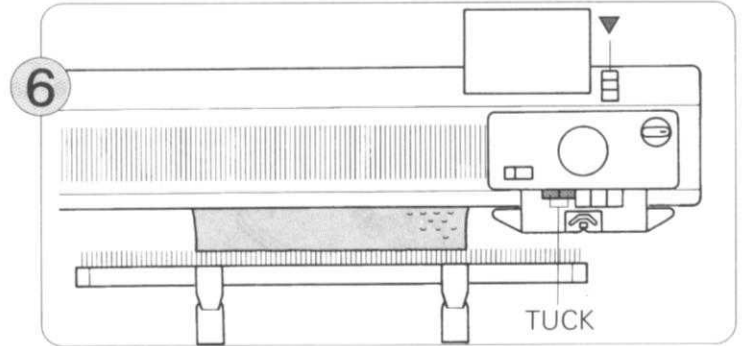

Push both Tuck Buttons at the same time. Set the Card Lock Lever at "▼" mark.

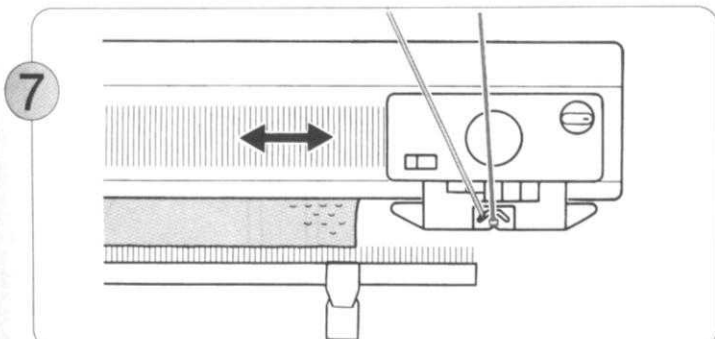

Move the K-Carriage back and forth. You are now knitting in Plated Tuck Stitch Pattern.

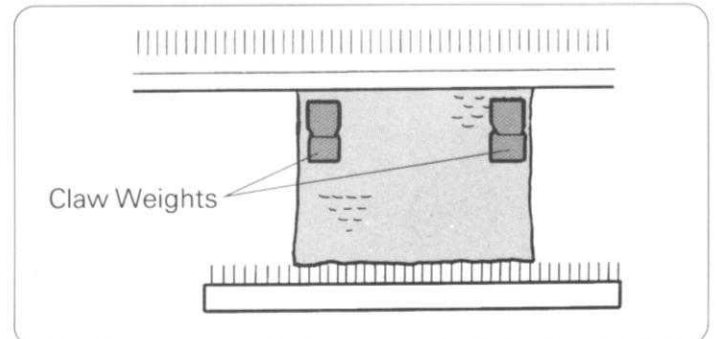

♣ Rehang the Claw Weights every 20 rows or so.



# [ MAKING YOUR ORIGINAL PATTERN ]

Make your original punch card with the card puncher and the blank card.

- ♣ Blank card and card puncher are optional accessory. Also pattern book which contains about 950 stitch patterns and prepunched card sets can be purchased separately.

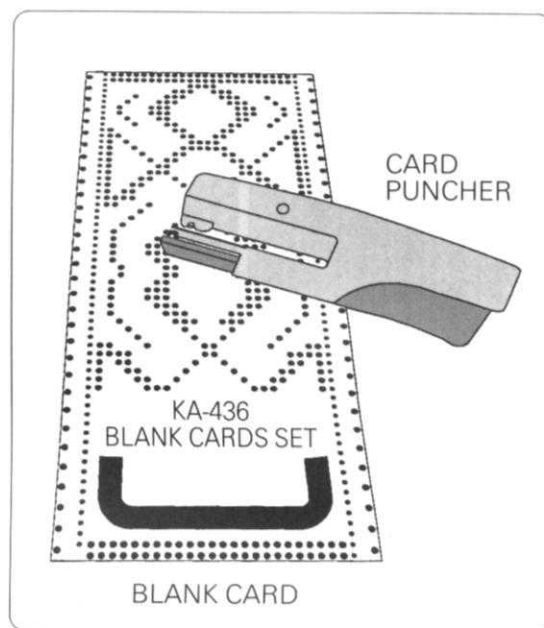

## • How to make the punch card

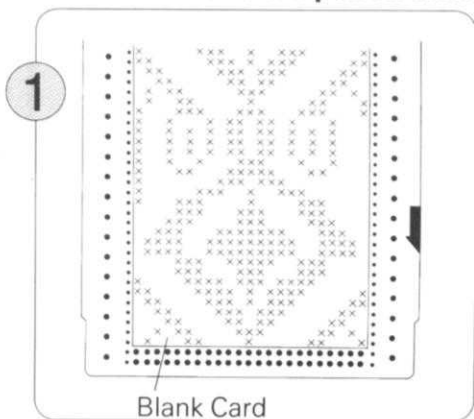

Mark on the BLANK CARD according to the pattern.

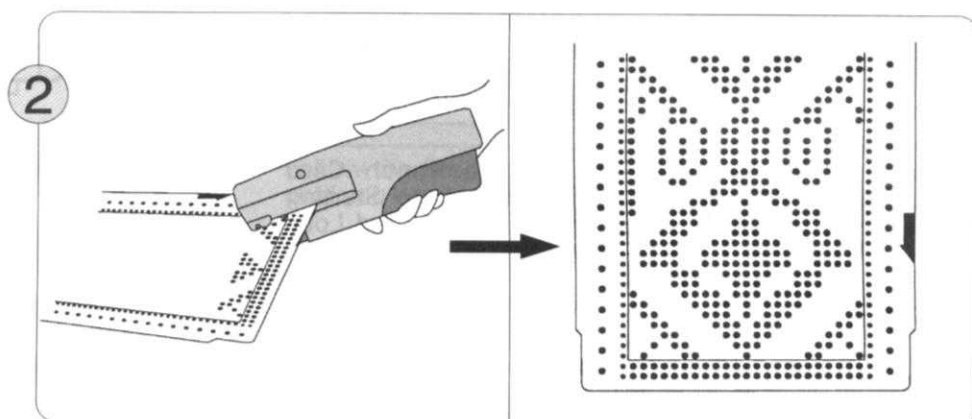

Punch out the marked blocks on the card by using the CARD PUNCHER.

- ♣ When you punch holes by mistake, you can mend the card with tape.

# USEFUL HINTS (PROBLEMS DURING KNITTING)

## [ WHAT TO DO WHEN YOU CANNOT KNIT SMOOTHLY ]

### 1. WHEN THE NEEDLES DON'T CATCH THE YARN PROPERLY

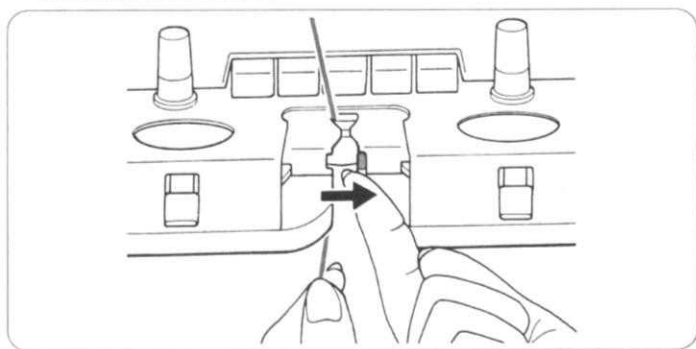

- Is the yarn correctly located in Feeder "A"?
- Is the Yarn Feeder Lever closed?

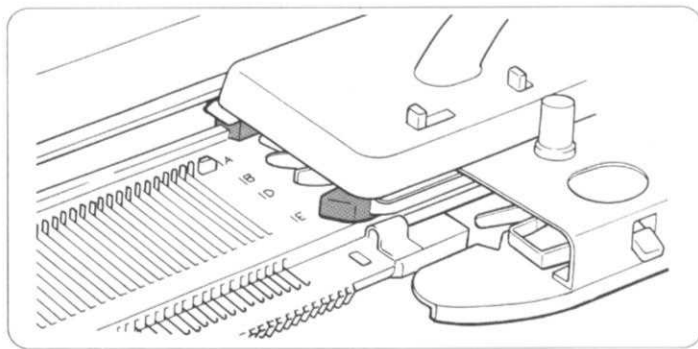

- Is the K-Carriage set correctly on the Needle Bed?

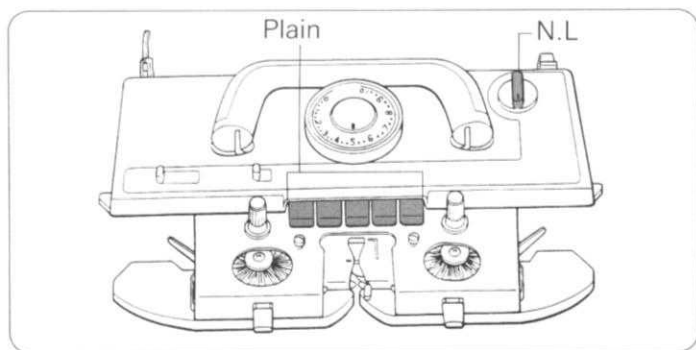

- Is the Change Knob set to N.L.?
- Has any Cam Button been pushed in?

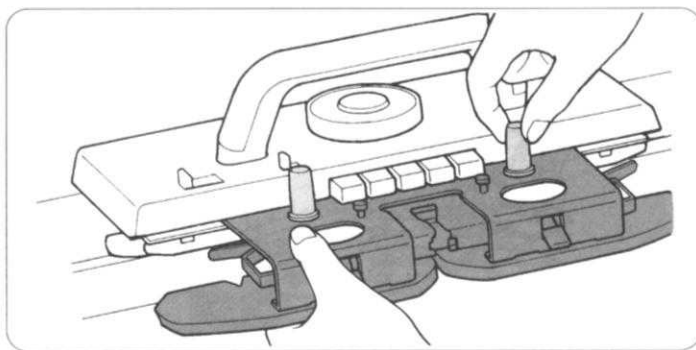

- Is the Sinker Plate Assembly joined correctly to the K-Carriage?

### 2. WHEN THE K-CARRIAGE IS HARD TO PUSH BACK AND FORTH

- Make sure that the Tension Dial and Tension Discs are adjusted according to the thickness of your yarn. (Tension Dial see P.18. Tension Disc see P.23).
- Make sure that the machine is not damaged or dirty. If the machine needs oiling or cleaning refer to P.103.
- Make sure you have threaded the yarn correctly into the Yarn Tension Unit. (See P.23).
- Make sure the yarn is flowing freely from the cone or ball.

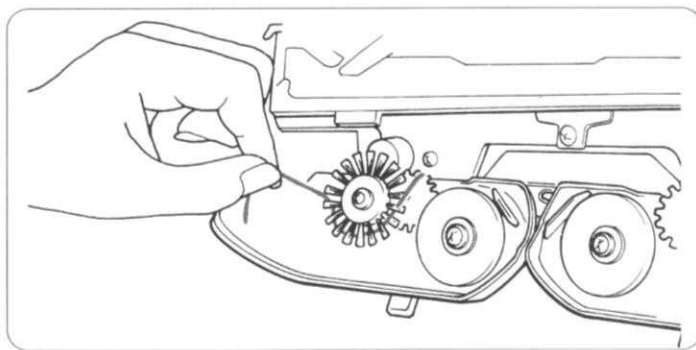

- Make sure the Wheel Brushes are rotating freely. If there is yarn wrapped around these, you must remove it.

### 3. WHEN STITCHES ARE NOT FORMED CORRECTLY

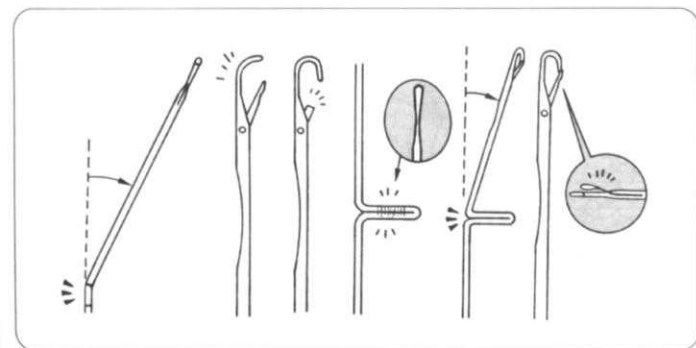

- Is the needle bent? If so, change it for a new one. (See P.102).
- Place the Rubber Wheels into working position. (See P.26).

#### 4. HOW TO PICK UP A DROPPED STITCH

- **Repairing a dropped stitch.**

Insert the Transfer Tool into the stitch on the row below the dropped stitch. Re-make the dropped stitch as illustrated.

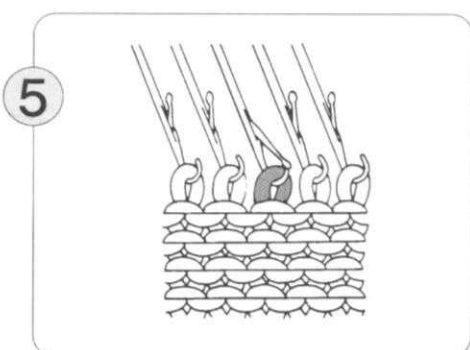
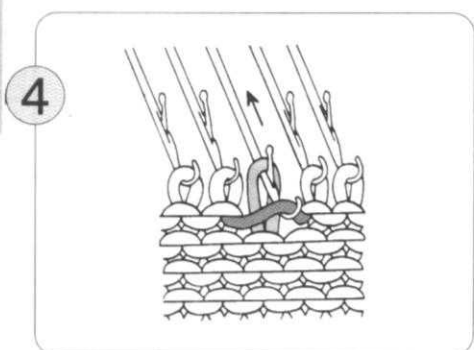
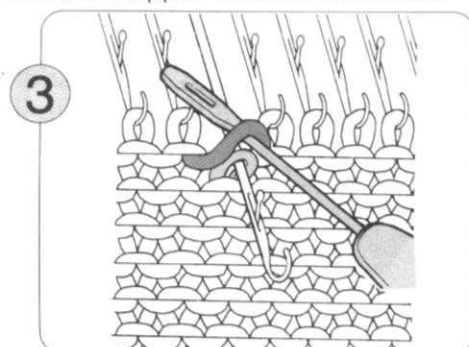
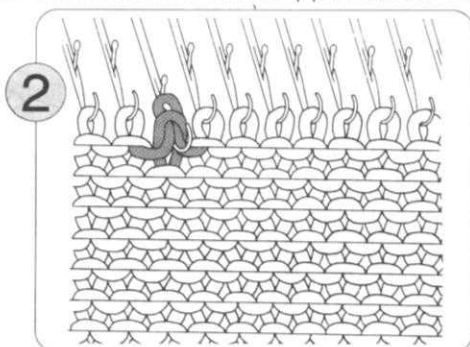
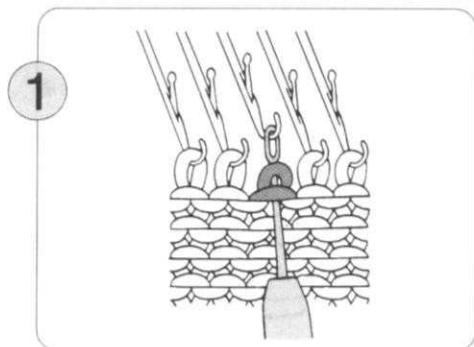

- **Repairing a stitch that has dropped several rows.**

Use the Latchet Tool from behind, and hook up the bottom stitch. Remake the dropped stitches row by row. On the final row, transfer the stitch from the Latchet Tool to a Transfer Tool, and replace it onto the needle.

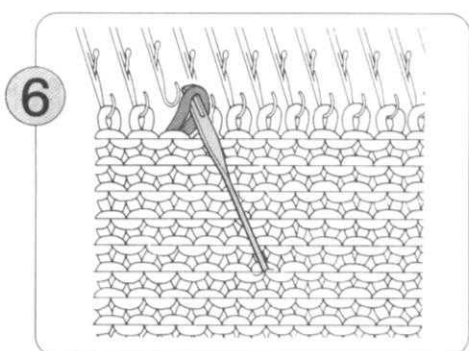
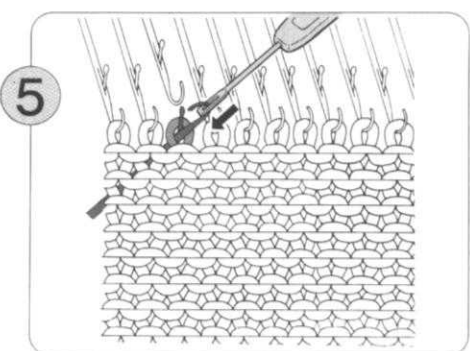
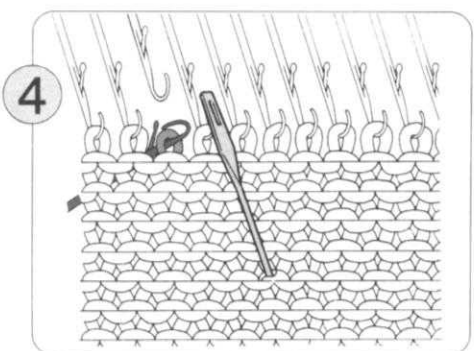
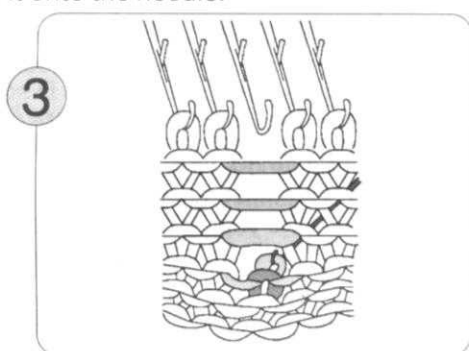
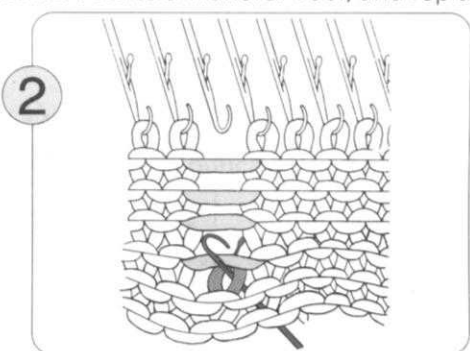
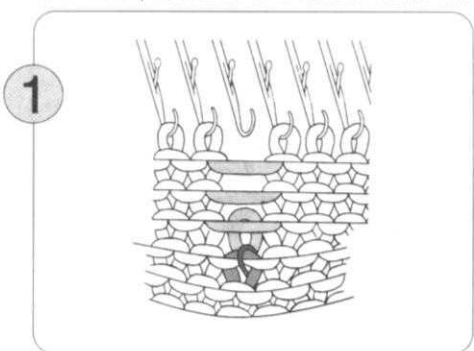

# [ WHAT TO DO IF YOU MAKE MISTAKES AS YOU KNIT STOCKING STITCH AND PLATING ]

## 1. IF THE CARRIAGE SHOULD JAM

- Do not attempt to move the K-Carriage by force. Proceed as follows:

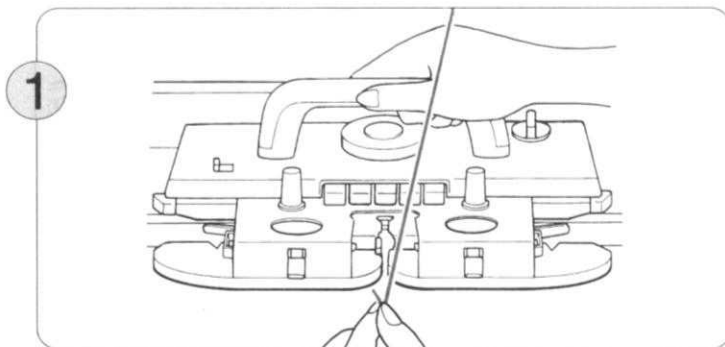

1 Take the yarn out of the Yarn Feeder "A".

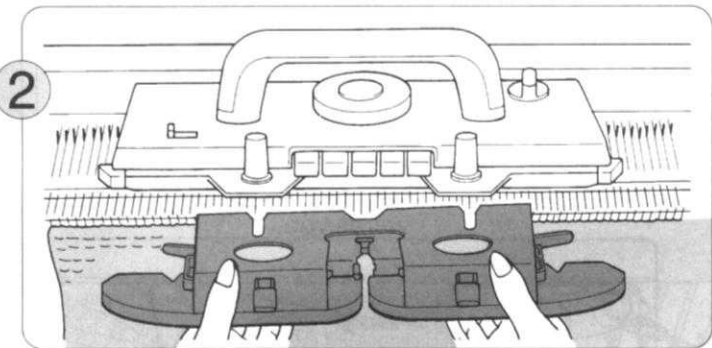

2 Loosen the knobs and remove the Sinker Plate Assembly.

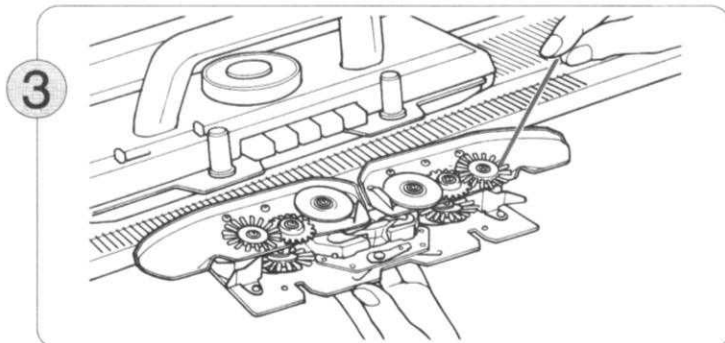

3 Untangle any yarn that has become wrapped around the Wheels.

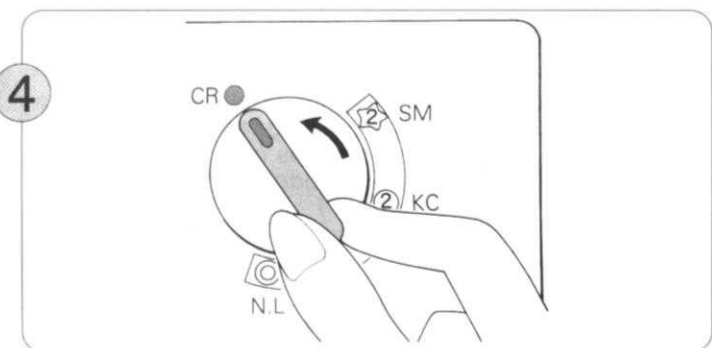

4 Set the Change Knob to CR to release the K-Carriage from the machine.

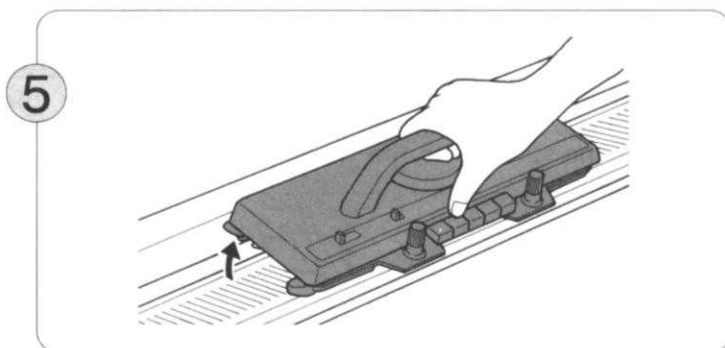

5 Lift up the K-Carriage towards you and remove it from the needlebed.

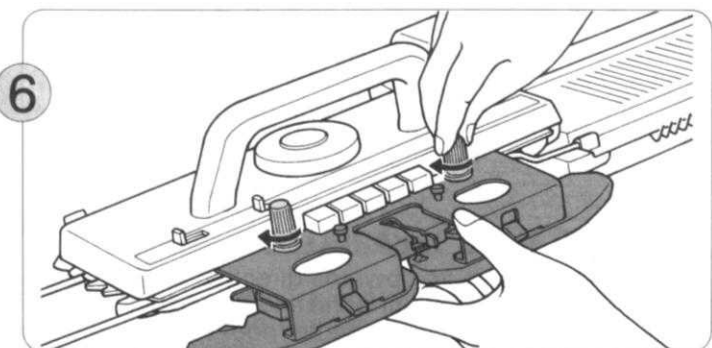

6 Place the K-Carriage onto either of the Extension Rails. Screw the Sinker Plate Assembly back onto the K-Carriage.

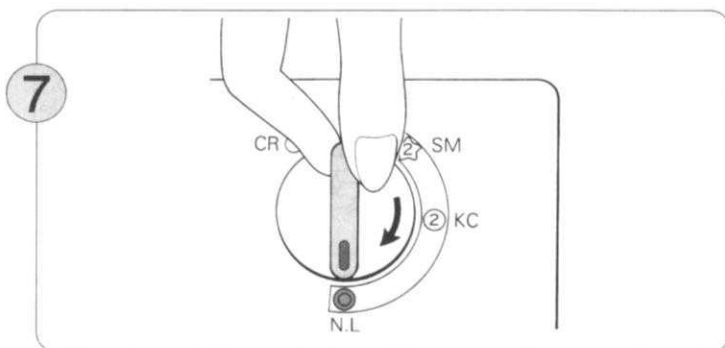

7 Return the Change Knob to N.L.



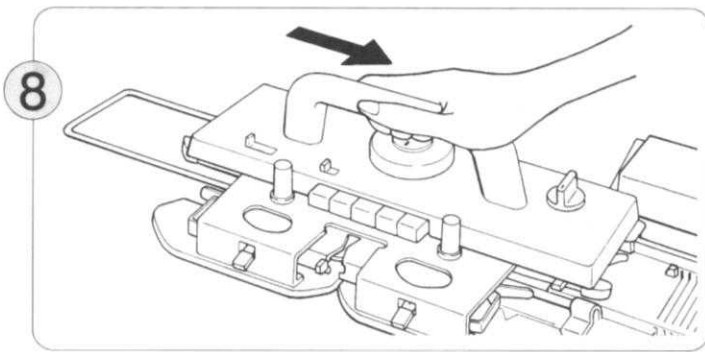

Slide the K-Carriage across onto the needlebed and check it is placed correctly.

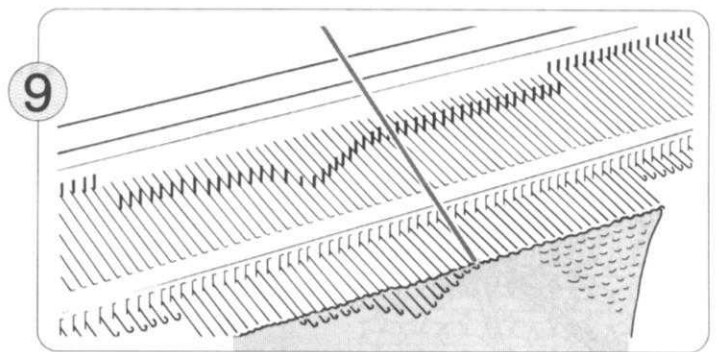

Using your Transfer Tool, replace any stitches that are on the stems of the needles back into the hooks, so that they will not drop off. (The following steps illustrate this technique).

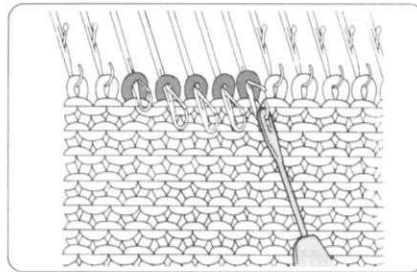
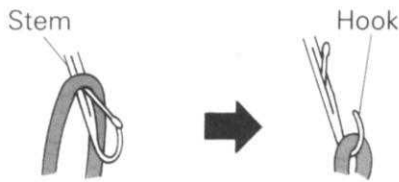

(1) Place the eye of the Transfer Tool into the hook of the needle.

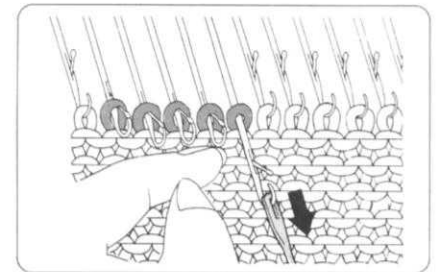

(2) Hold the Transfer Tool in line with the needle and pull it towards you.

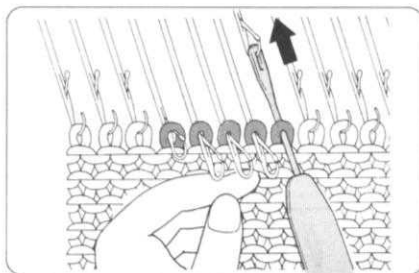

(3) Push the Transfer Tool away from you towards the machine until the stitch is on the Transfer Tool.

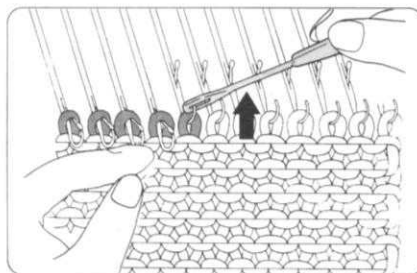

(4) Transfer the stitch into the hook of the needle.

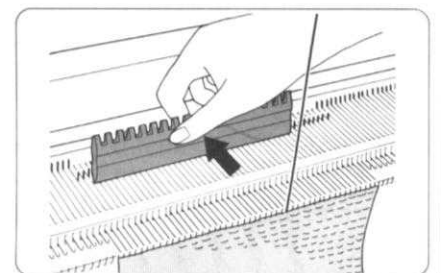

(5) When all stitches are safely in the hooks of the needles, align all needles in B position using the flat edge of the 1/1 Pusher.

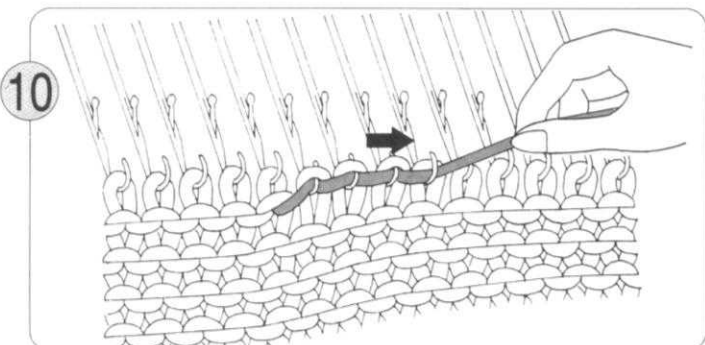

Pull the yarn sideways slightly so that it becomes tight in the needle hooks.

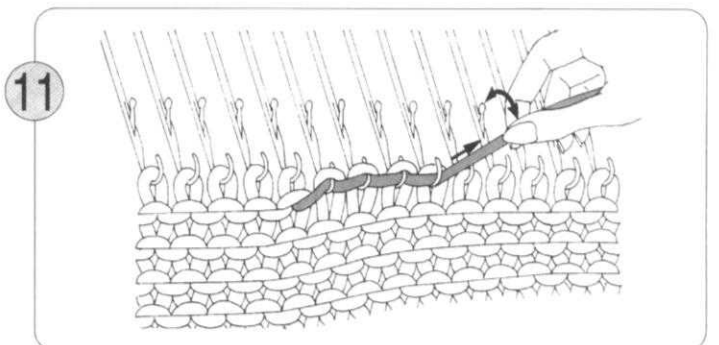

Now pull the yarn in an upwards direction to unravel the knitting. The stitches are undone and those from the row below will slip into the needle hooks. Work a few stitches at a time and repeat Steps 10 & 11 across the row.

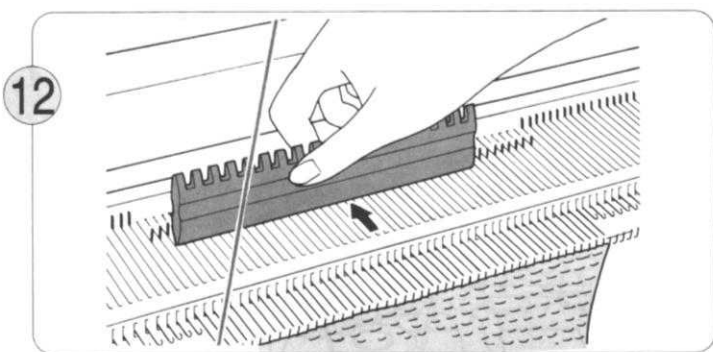

After unravelling a row check that all the stitches are in the needle hooks. Using the flat side of the 1/1 Needle Pusher, align the needles in B position.

**14**  
Don't forget to wind back the Row Counter and Knit Leader (if used) by the number of rows you have unravelled.  
♣ You don't need to count the last row if the Row Counter and the Knit Leader Tripper didn't operate e.g. if you made the mistake before the K-Carriage had passed the Trippers.

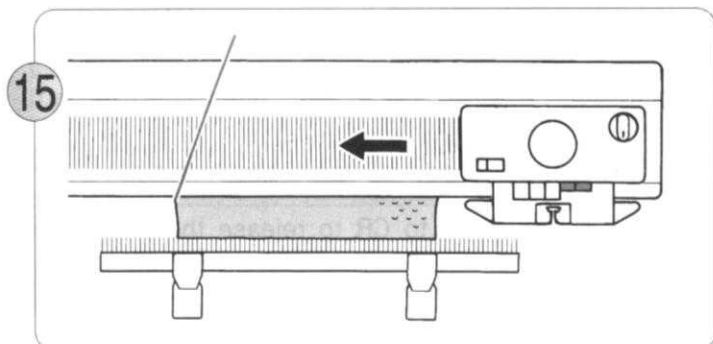

If the yarn is now on the opposite side of the knitting to the K-Carriage, you can move the K-Carriage across the needles without knitting as follows:

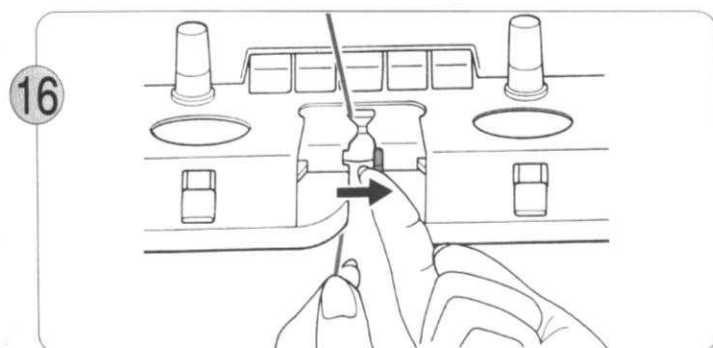

Thread up the yarn into Feeder "A". Put the Row Counter and Knit Leader Tripper back in operation.

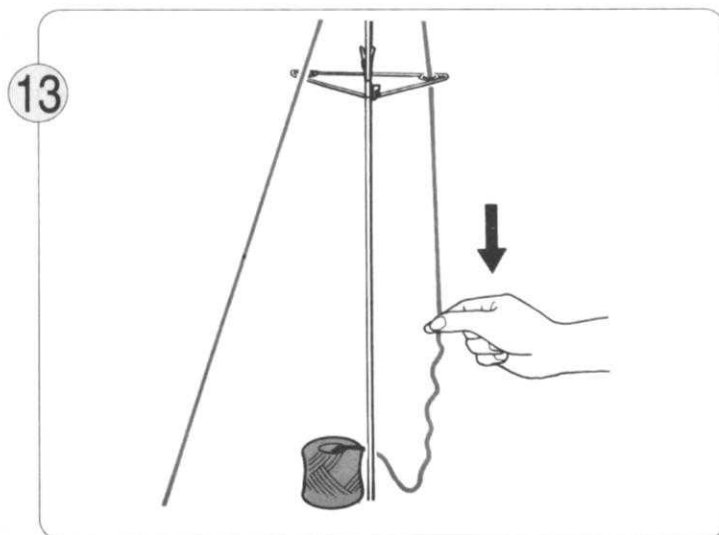

Pull down the loose unraveled yarn from behind the Rear Yarn Guide.  
♣ To unravel several rows of knitting, repeat Steps 10 - 12

**HOW TO PASS THE K-CARRIAGE ACROSS THE NEEDLES WITHOUT KNITTING**

- (1) Make sure all the needles are in B position.
- (2) Push both Part Buttons.
- (3) If you are using the Row Counter or the Knit Leader, set the Trippers to non-working position.
- (4) Move the K-Carriage across to the other side of the needlebed.
- (5) Cancel both Part Buttons by sliding the Cam Button Release Lever.

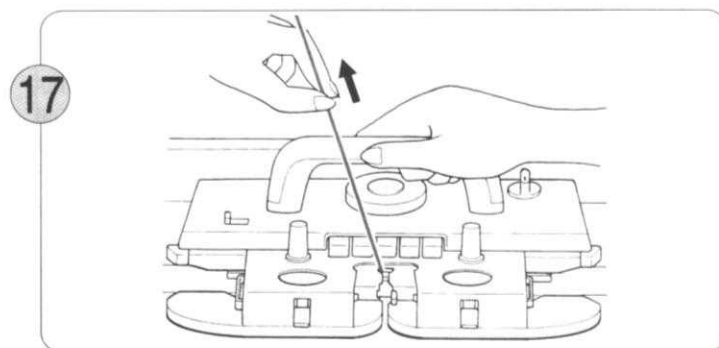

Continue knitting with the K-Carriage, pulling the yarn slightly on the first row to remove any slackness.

**2. IF YOU WANT TO UNRAVEL SOME KNITTING**

Should you wish to unravel a row or rows of knitting, for example if you find you have knitted too many, follow Steps 10 - 17 on P.61 & 62.

# [ WHAT TO DO IF YOU MAKE MISTAKES AS YOU KNIT PATTERN KNITTING ]

## 1. IF THE K-CARRIAGE SHOULD JAM

- Do not attempt to move the K-Carriage by force. Proceed as follows:

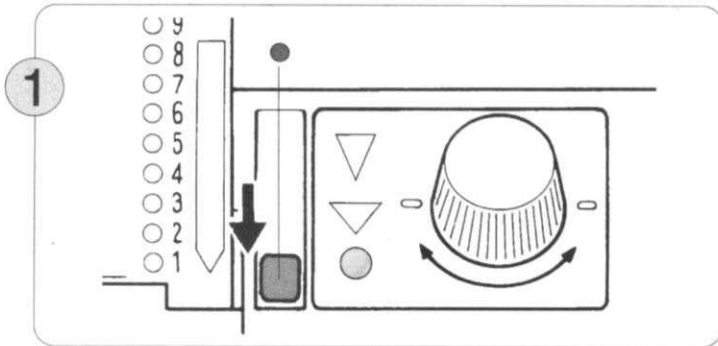

Set the Card Lock Lever at "●" mark.

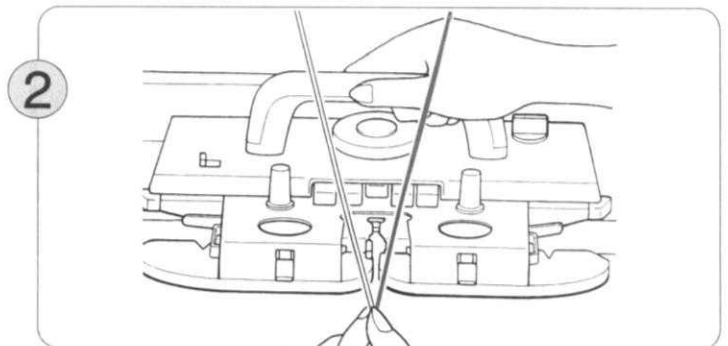

Take the yarn out of the Yarn Feeder.

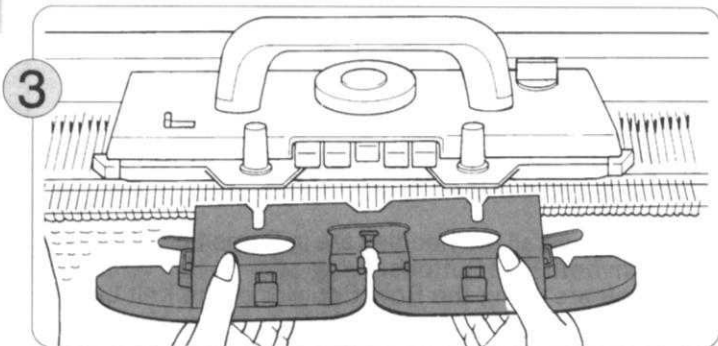

Loosen the knobs and remove the Sinker Plate Assembly.

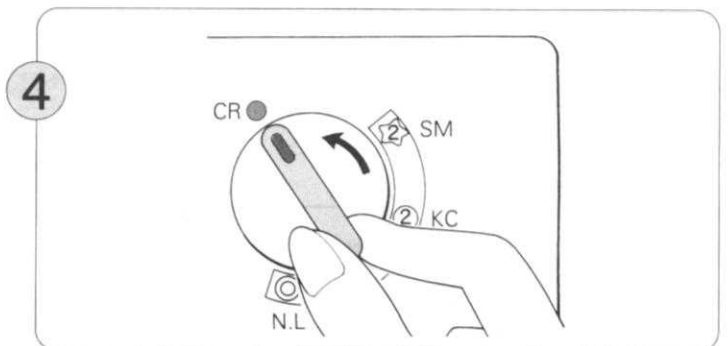

Set the Change Knob to CR to release the K-Carriage from the machine.

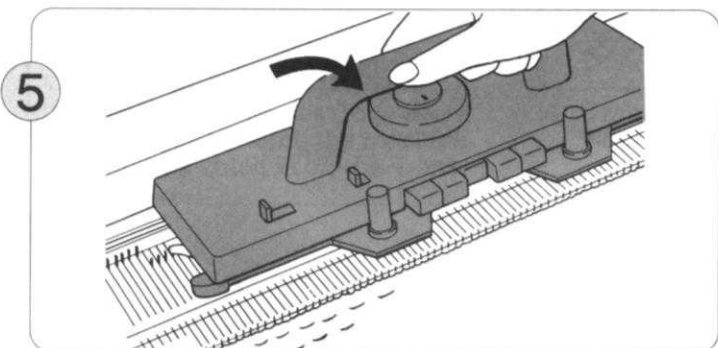

Lift up the K-Carriage towards you to remove it. Place it onto either of the Extension Rails. Set the Change Knob to N.L.

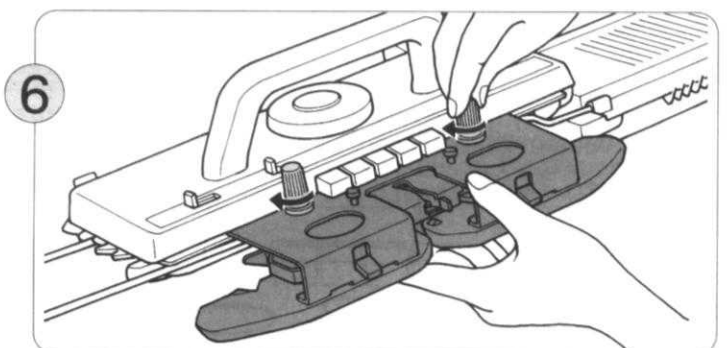

Screw the Sinker Plate Assembly back onto the K-Carriage.

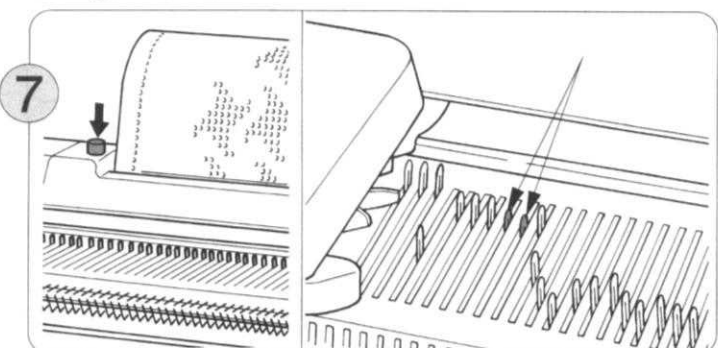

If some stitches have slipped back down the Needle Bed, push the Push Button.

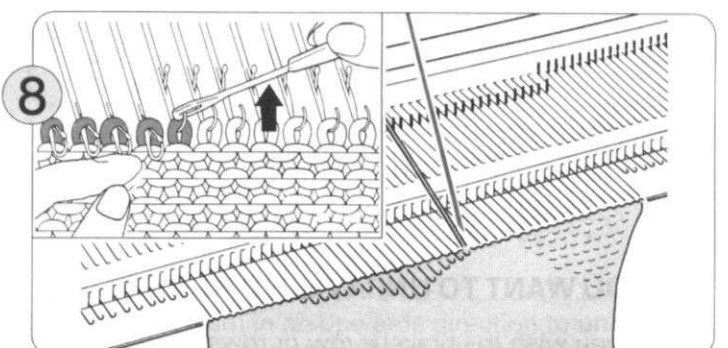

Using your Transfer Tool, replace any stitches that are on the stems of the needles back into the hooks, so that they will not drop off. (Refer to Step ① (1) - (5) on P.61.)

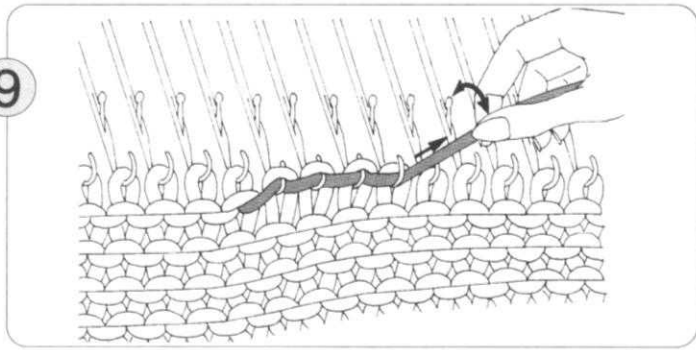

9 Unravel the row. (Refer to Steps 10 - 13 on P.61-62).  
 ♣ If you have unravelled several rows of knitting, remember the number of rows you have unravelled. Even if you stopped the last row in the middle, you must still count this as one row.

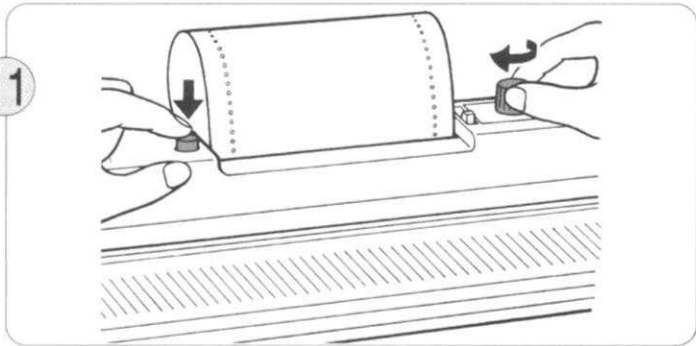

11 Wind back the Punch Card according to the number of rows you have unravelled.

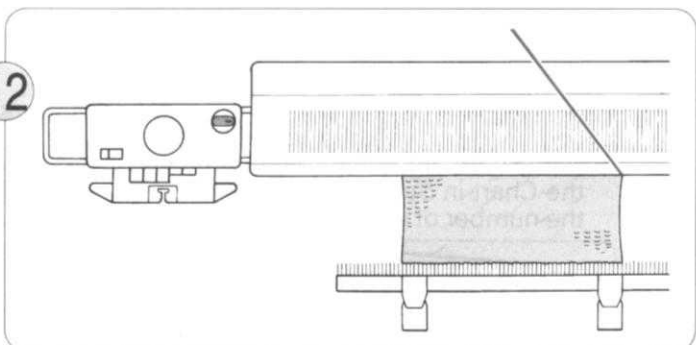

12 Place the K-Carriage at the opposite end of the needle bed to the yarn. (If the yarn is on the same side as the K-Carriage, refer to P.62 for how to pass the carriage across the needles without knitting). Push both Part Buttons and set the Change Knob to KC or SM.

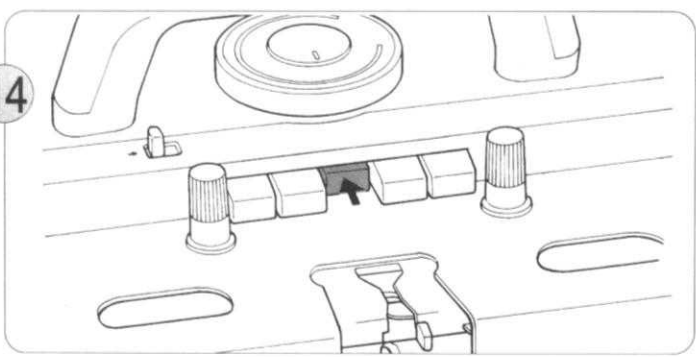

14 Push the Cam Buttons according to the pattern.

10 Don't forget to wind back the Row Counter and Knit Leader (if used) by the number of rows you have unravelled.  
 ♣ You don't need to count the last row if the Row Counter and the Knit Leader Tripper didn't operate e.g. if you made the mistake before the K-Carriage had passed the Trippers.

WHEN KNITTING DOUBLE LENGTH PATTERNS WIND BACK THE CARD ACCORDING TO THE FOLLOWING CHART

NUMBER OF UNRAVELLED ROWS	DIRECTION IN WHICH THE CARRIAGE HAS BEEN MOVED	
	→	←
1	Rewind the Punch card 0 step (s)	Rewind the Punch card 1 step (s)
2	1	1
3	1	2
4	2	2
5	2	3
6	3	3
7	3	4
⋮	⋮	⋮
⋮	⋮	⋮
⋮	⋮	⋮

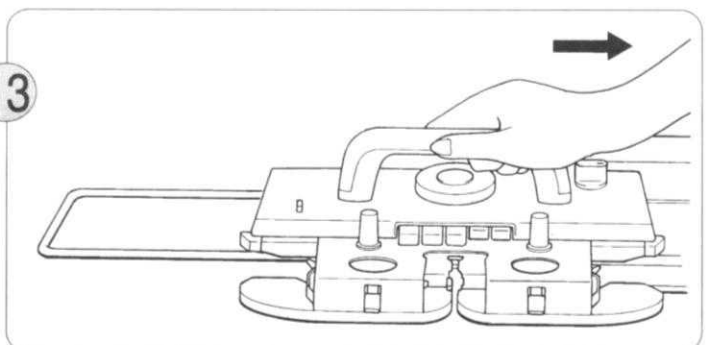

13 Move the K-Carriage across the needle bed to the same side as the yarn. The needles are selected for the pattern.  
 ♣ If you are using the Row Counter or the Knit Leader, set the Tripper to non-working position.

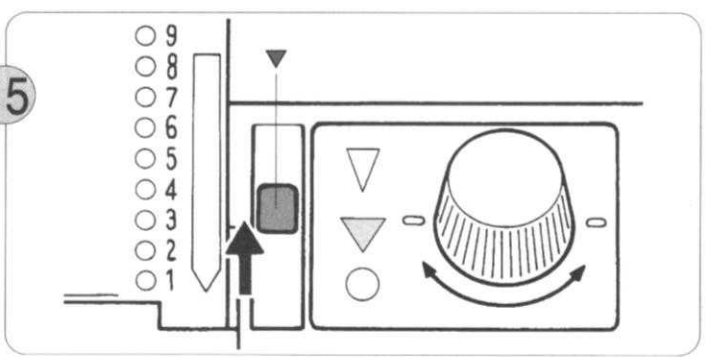

15 Set the Card Lock Lever at "▼" mark. (When working in Double Length Pattern, set it at "▼" mark.)



16

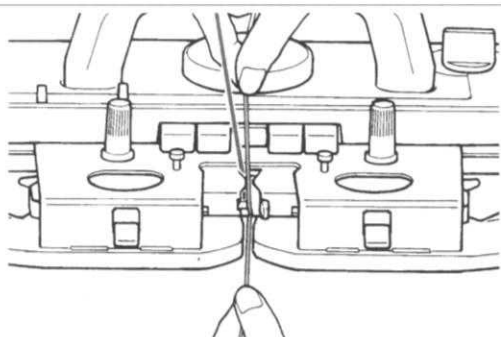

Thread up the yarn into Yarn Feeder.

- ♣ If you are using contrast yarn, plating yarn or weaving yarn, don't forget to thread this up as well.

17

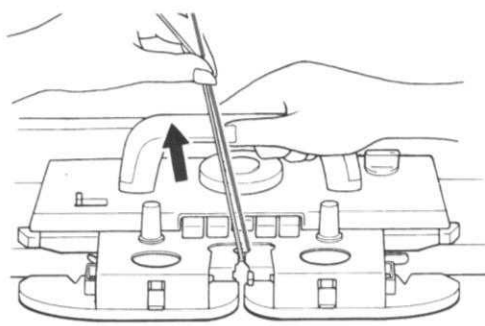

Continue knitting with the K-Carriage, pulling the yarn slightly on the first row to remove any slackness.

- ♣ Put the Row Counter and Knit Leader Tripper back in operation.

## 2. IF YOU WANT TO UNRAVEL SOME KNITTING (WHEN THE CARRIAGE HAS GONE PAST THE END OF THE KNITTING)

- 1 Do not move the K-Carriage. Set the Card Lock Lever at "o" mark.
- 2 If the Indicator shows same direction as the K-Carriage is moving, then the Card has rotated on to the next row.
  - ♣ When working in Double Length Pattern and the K-Carriage is at the left side of the machine, the Card has not been rotated even if the Indicator has changed direction.

When the Card has not been rotated .....

- 3 Unravel the rows.
- 4 Wind the Card back by the same number of rows as you have unravelled.
  - ♣ When working in Double Length Pattern, see the Chart in Step 11 on P.64.

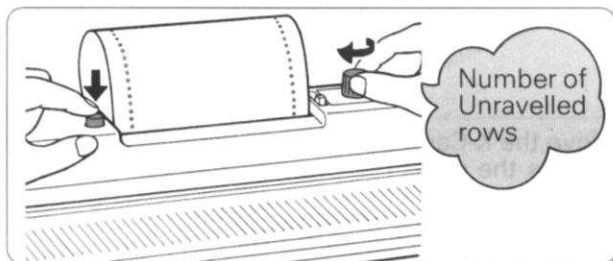

- 5 Follow Steps 12 - 17 on P.64 - 65.

When the Card has been rotated.....

- 3 Unravel the rows.
- 4 Wind the Card back by the same number of rows as you have unravelled plus one extra row.
  - ♣ When working in Double Length Pattern, refer to the Chart in Step 11 on P.64 and wind back by the number of rows indicated plus one extra row.

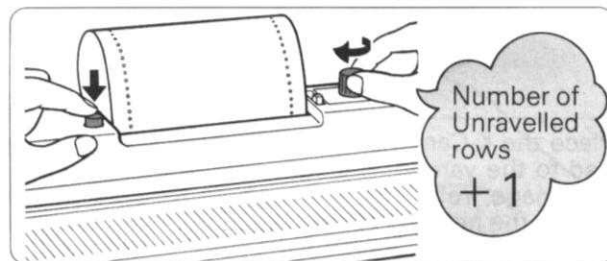

- 5 Follow Steps 12 - 17 on P.64 - 65.

# [ WHAT TO DO IF YOU MAKE MISTAKES AS YOU KNIT LACE OR FINE LACE PATTERN ]

## 1. IF THE L-CARRIAGE SHOULD JAM

- Do not attempt to move the L-Carriage by force. Proceed as follows:

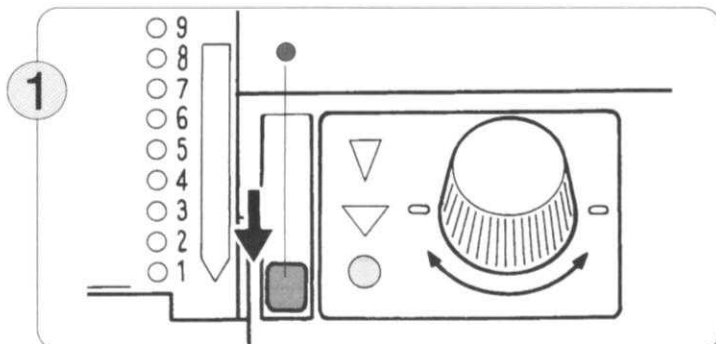

Set the Card Lock Lever at "●" mark.

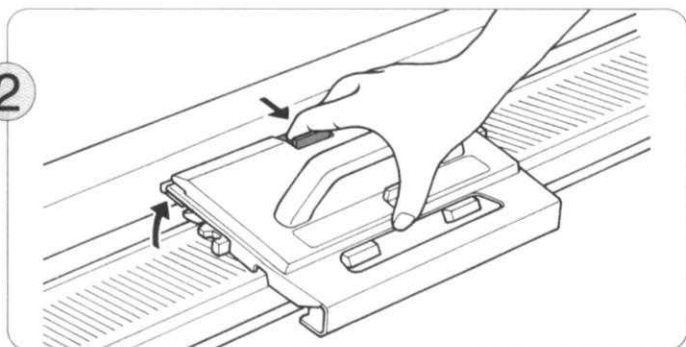

Remove the L-Carriage by pushing the Release Button. If the L-Carriage is caught on the needles, take care when removing it.

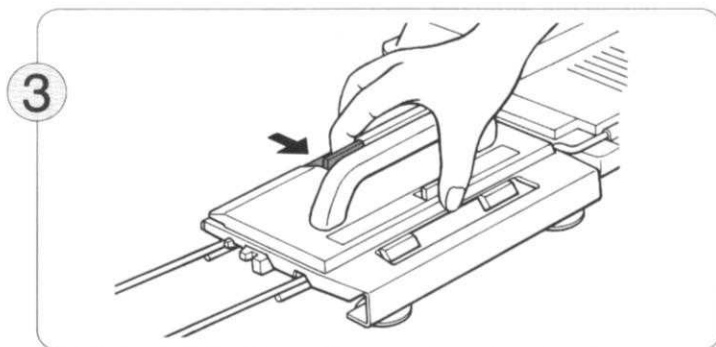

Place the L-Carriage securely on the left Extension Rail using the Release Button.

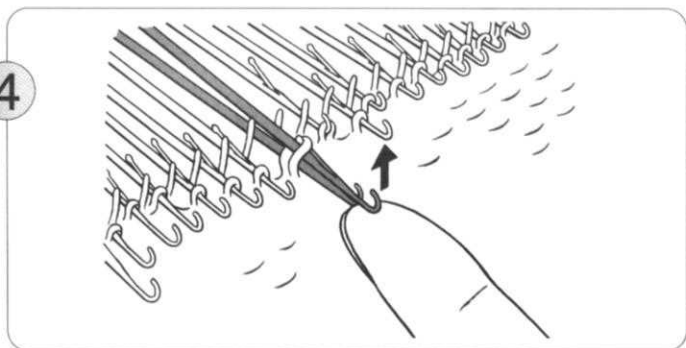

If the needles are caught over each other, separate them by lifting the tips as shown above.

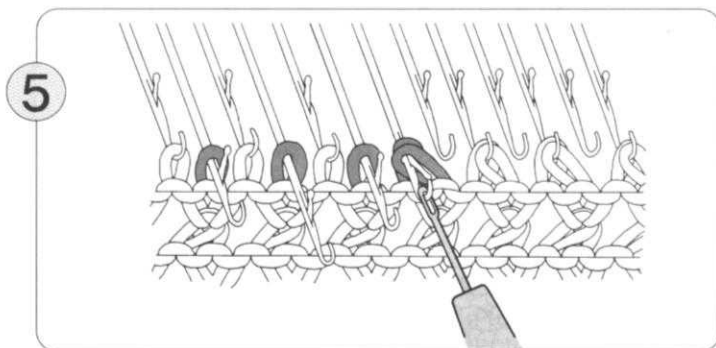

Use the Transfer Tool to replace any stitches on the stems of the needles back into the hooks.

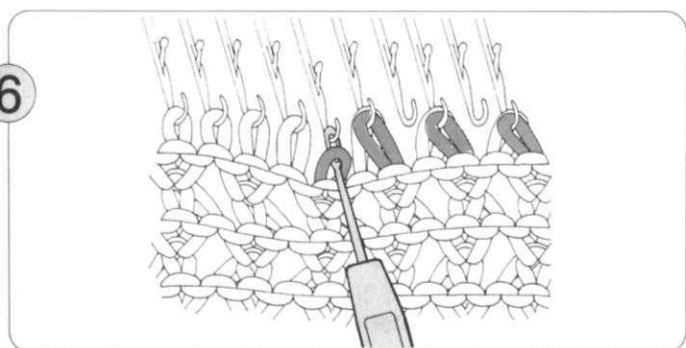

Return any stitches that have been transferred back onto the adjacent needles using the Transfer Tool.

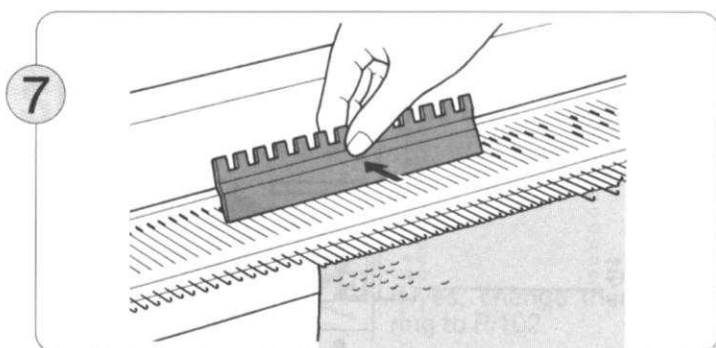

Bring all needles back into B position.

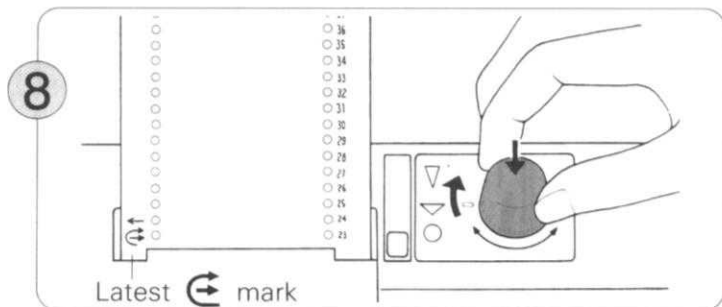

Wind back the Punch Card to the latest ↻ mark.

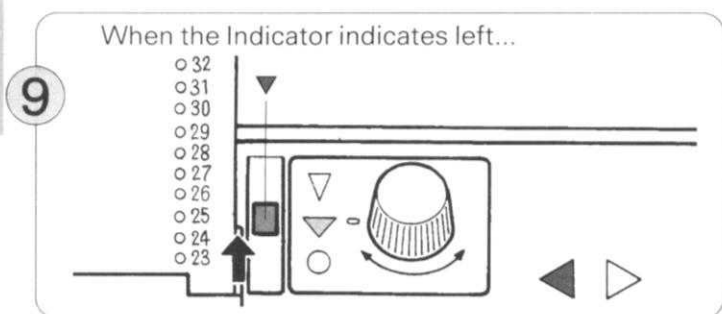

When the Carriage Direction Indicator indicates left, set the Card Lock Lever at "▼" mark. Move the L-Carriage from left to right and continue knitting.

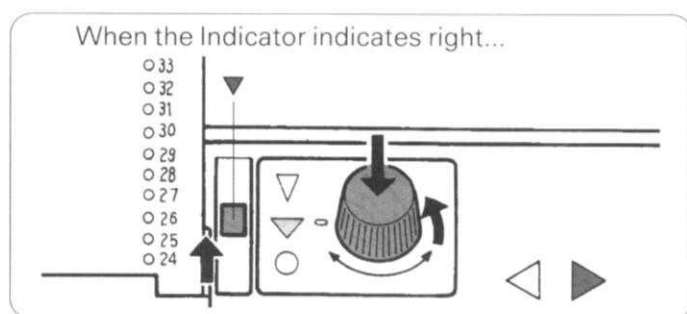

When the Carriage Direction Indicator indicates right, wind the card forward one row and set the Card Lock Lever at "▼" mark. Move the L-Carriage from left to right and continue knitting.

## 2. IF YOU WANT TO UNRAVEL SOME KNITTING

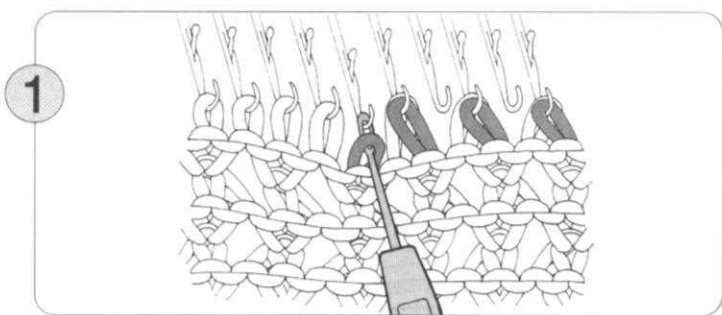

Set the Card Lock Lever at "●" mark. Return any transferred stitches to the adjacent needles and put all needles in B position.

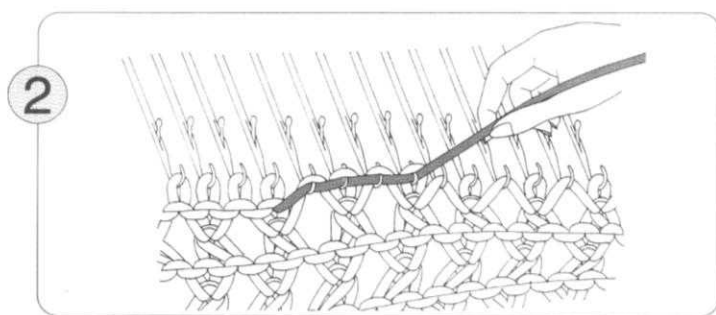

Unravel the stocking stitch rows (2 rows).  
♣ Wind back the Row Counter or Knit Leader if necessary.

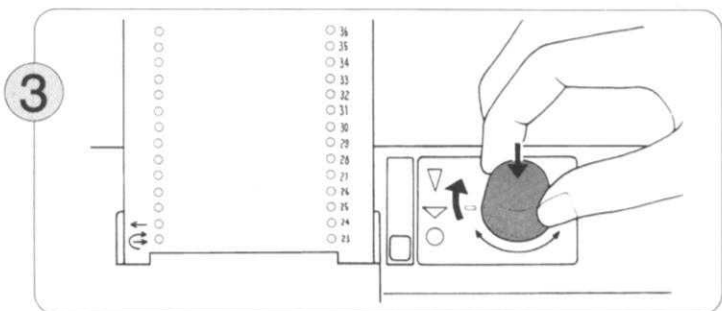

Wind back the Punch Card to the latest ↻ mark.

4 Repeat Steps 1 to 3 above as necessary.

5 Knit 2 rows by K-Carriage and follow Step 9 on this page.

# [ HOW TO MOVE THE K-CARRIAGE ACROSS THE NEEDLE BED WITHOUT KNITTING ]

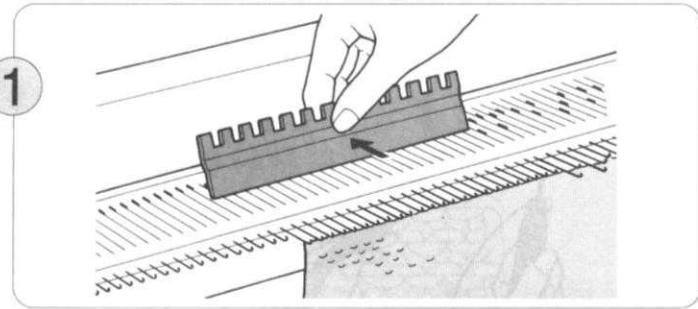

Replace any stitches that are on the stems of the needles back into the hooks and bring the needles (except those in E position) into B position.

**2**

- When all the needles are in B position...
- When all the needles are in B position and to select them without knitting...
- When needles are in B and E position...
- When needles are in B and E position and to select them without knitting...

Set the K-Carriage and operate it.

# [ HOW TO CHECK IF THE NEEDLES ARE SELECTED CORRECTLY ]

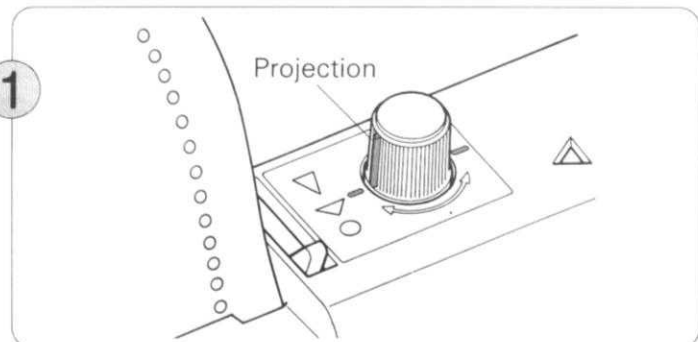

Set the projection of the Feeding Knob at  mark on the Panel without pushing it.

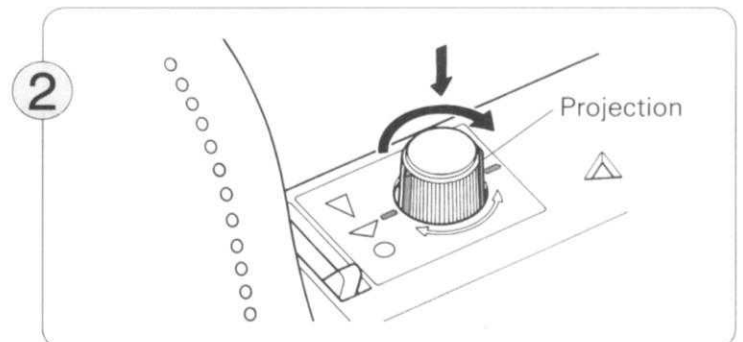

Press down on the Feeding Knob and turn it one hundred and eighty degrees in a clockwise direction. The card will feed back seven rows, and you can see the pattern perforations for the actual row you are knitting.

# [ CHECK FOLLOWING POINTS IF THE NEEDLES ARE NOT SELECTED CORRECTLY... ]

- Is the card inserted correctly?

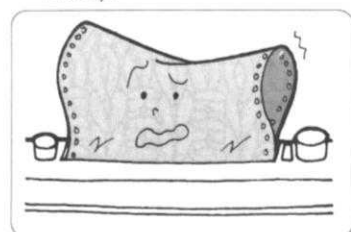

If not, insert it again correctly.

- Are there any bent or broken needles?

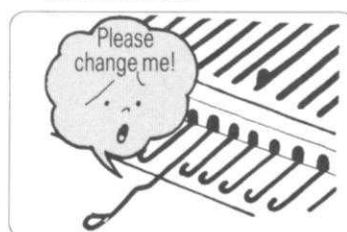

If yes, change them referring to P.102.



# MAKING GARMENTS

## 【HOW TO USE THE TRANSFER TOOL】

- Use when you decrease, increase, transfer stitches, etc.

- How to hold the transfer tool.

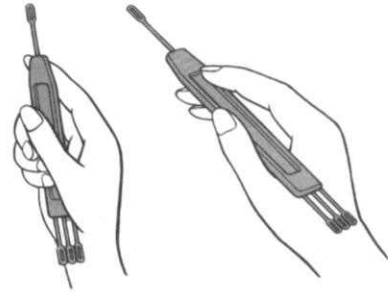

### Transferring Stitch

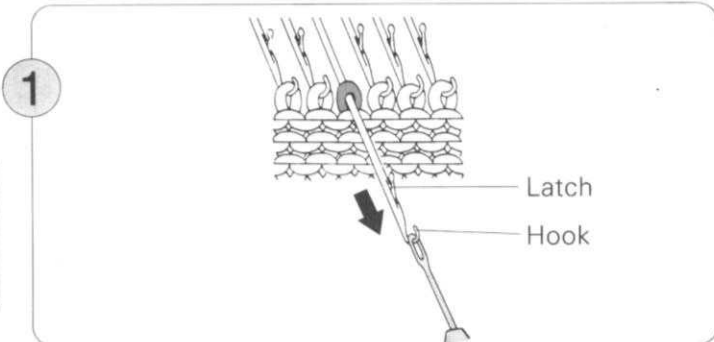

Place the eye of a single Transfer Tool over the needle hook, and pull the needle towards you until the stitch passes behind the latch.

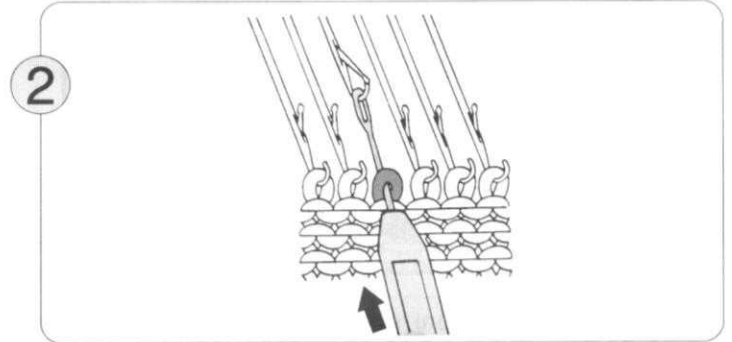

Holding the Transfer Tool in line with the needle, use it to push the needle back so that the stitch slips onto the Transfer Tool.

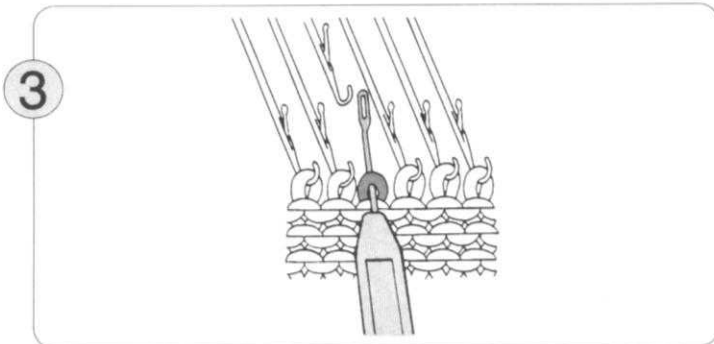

Lift the Transfer Tool together with the stitch, and place it onto the adjacent needle.

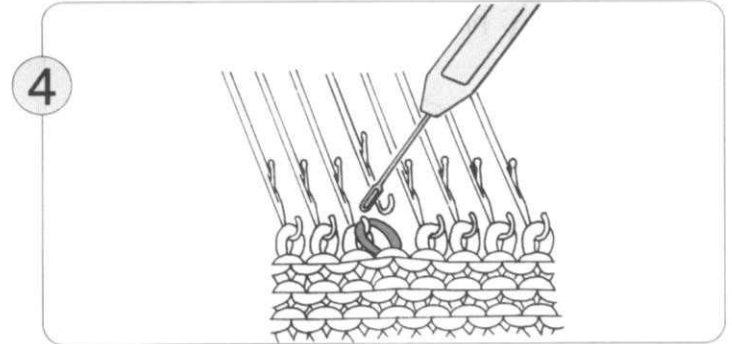

Lift the Transfer Tool slightly so that the stitch slides off into the hook of the needle. Then remove the Transfer Tool. One stitch has been transferred.

## 【HOW TO USE THE LATCHET TOOL】

- Use when you make ribbing, pick up dropped stitches, etc.

- How to hold the latchet tool

Hook ← → Latch



- Making Rib by hand

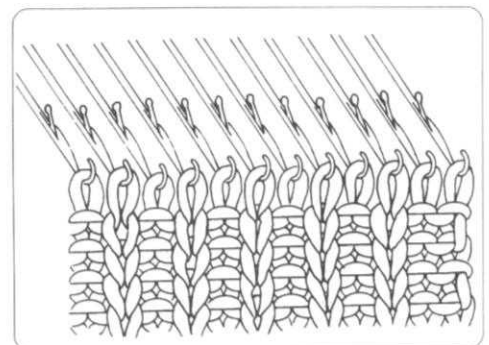

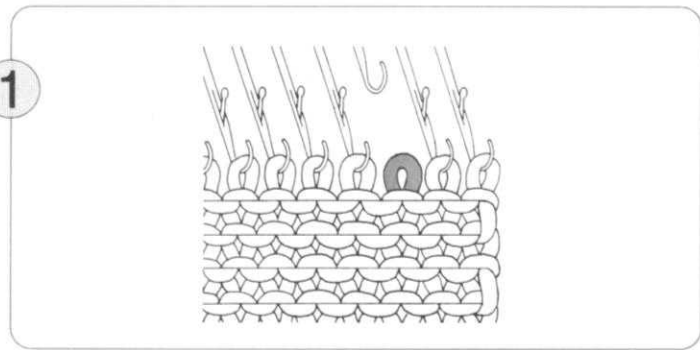

1 Bring the needle for your first "purl" stitch forward to E position by hand. Take the needle back to A position so that the stitch drops off the needle.

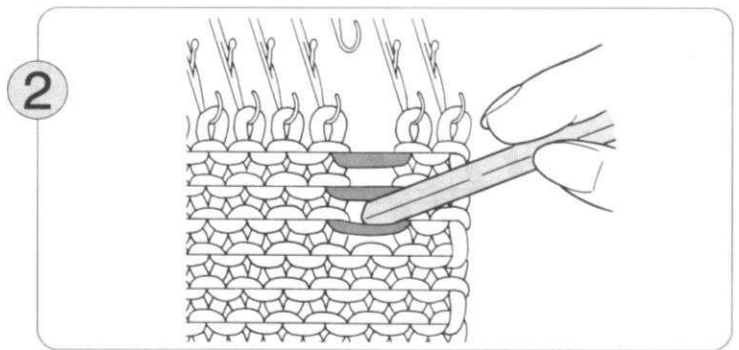

2 Using the tip of your Latchet Tool, ladder the stitch down to within a few rows of the point where you want to start the ribbing.

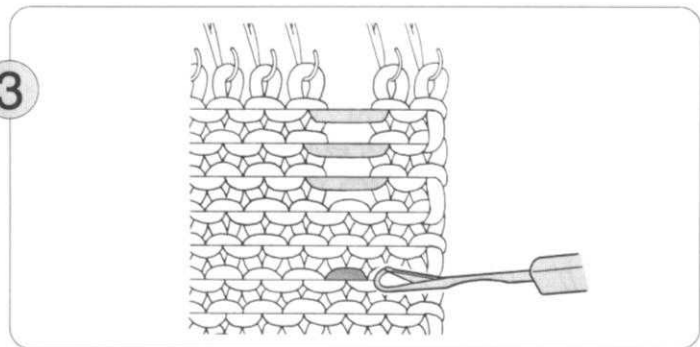

3 With the Latchet Tool hook the bottom stitch where the ribbing will begin.

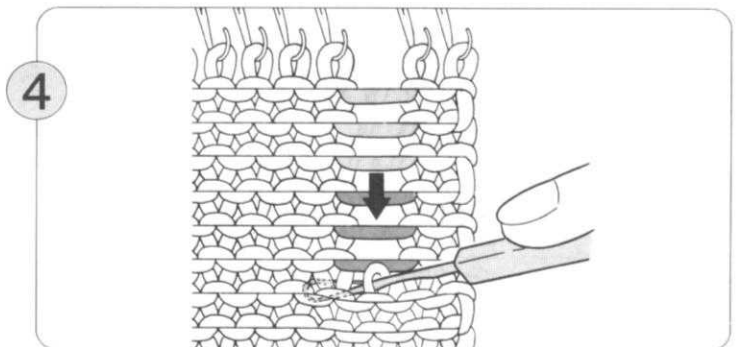

4 Push down with the Latchet Tool so that the last few stitches drop.

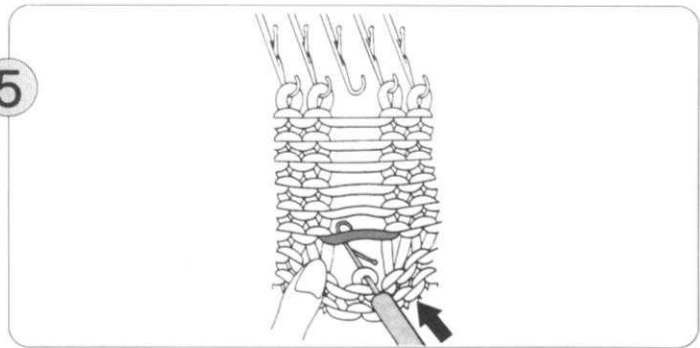

5 Hold the knitting firmly with your other hand. Push the Latchet Tool forward to put the bottom stitch behind the latch.

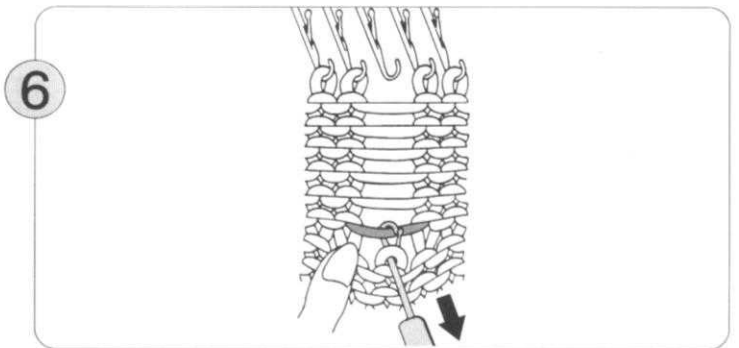

6 Catch the next horizontal bar above with the hook of the Latchet Tool. Pull the Latchet Tool towards you.

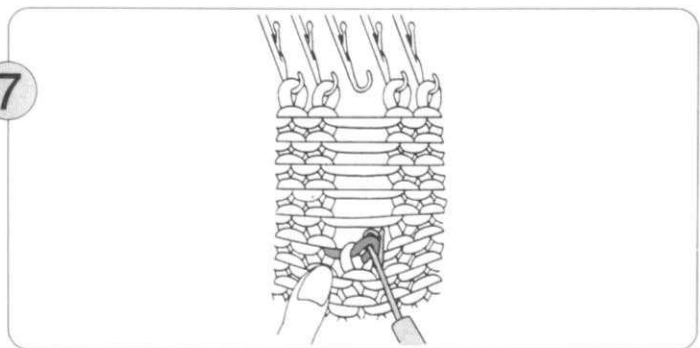

7 The latch closes with this new stitch in the hook. Gently slip the old stitch off the end of the Latchet Tool. A purl stitch has been formed.

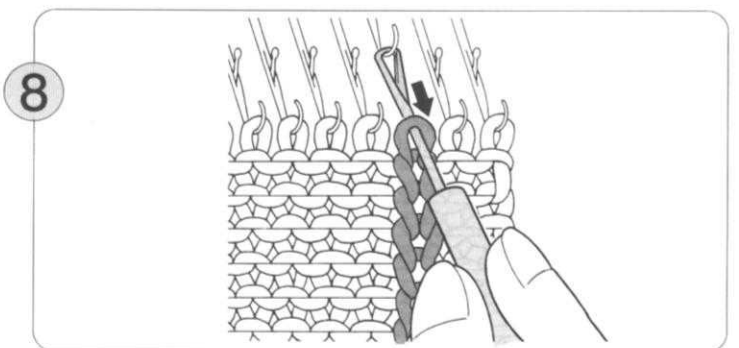

8 Continue in this way until you reach the top, then hook the last stitch onto the needle as shown.

# [ HOW TO INCREASE STITCHES ]

## ● Increasing one stitch

### Simple method

The K-Carriage and yarn are at the side where you wish to increase the stitch.

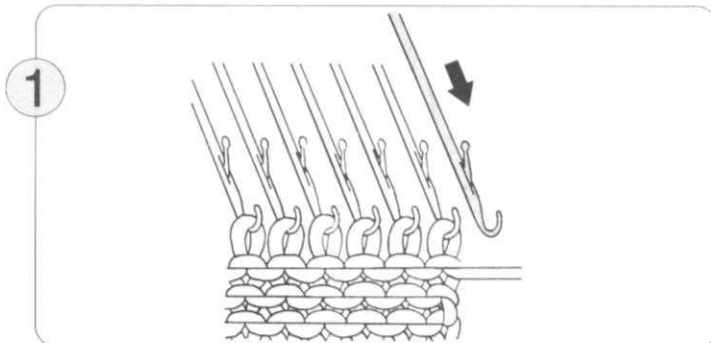

On the K-Carriage side, bring one edge needle forward from A to B position.

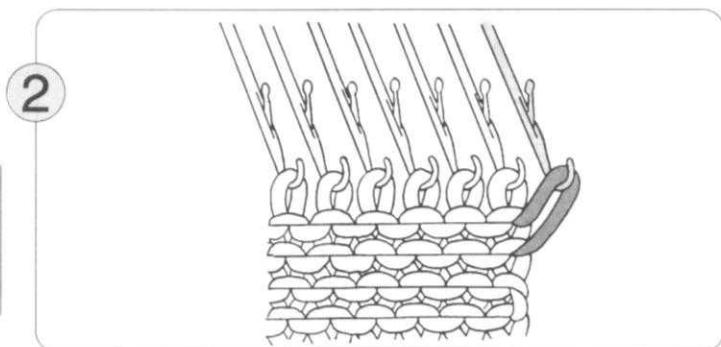

Knit one row to the left. The empty needle picks up the yarn.

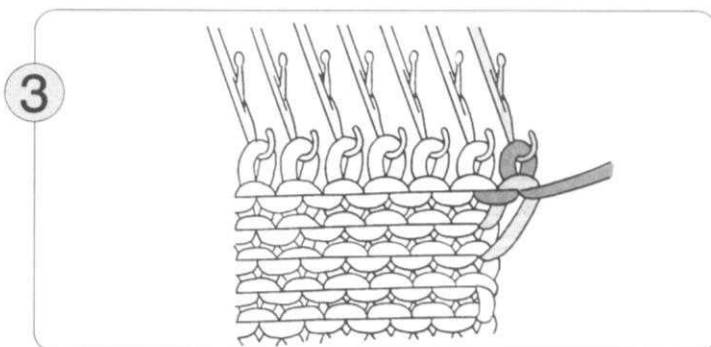

Knit one row to the right. The new stitch knits.

### Fully fashioned method

The K-Carriage can be at either end of the needlebed.

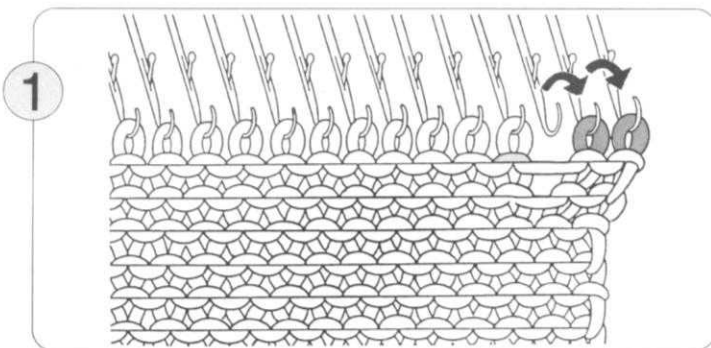

Using the 1 x 2 Transfer Tool, move two stitches out by one needle, so that the third needle from the edge becomes empty.

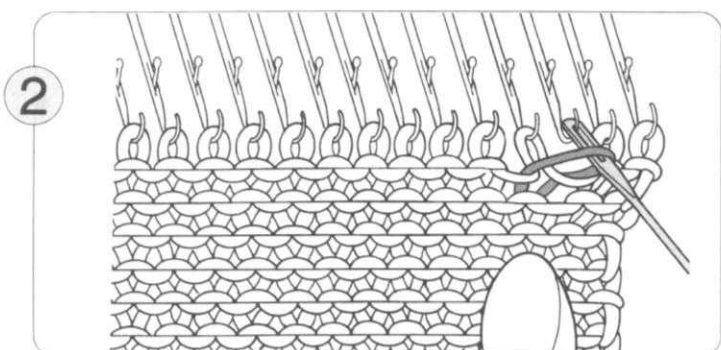

Pick up the loop as shown using the Transfer Tool.

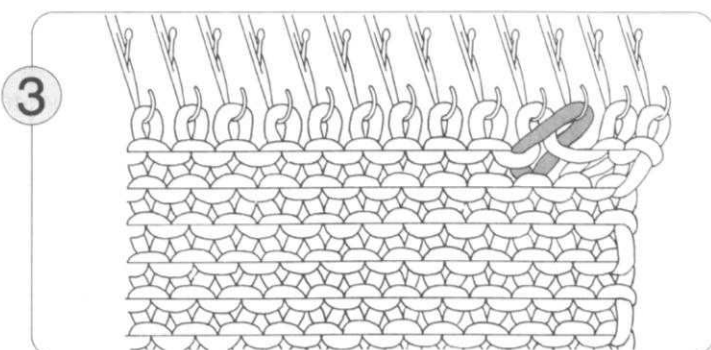

Place this loop onto the empty needle and continue to knit.

● **Increasing several stitches**

The K-Carriage and yarn are at the side where you wish to increase the stitches.

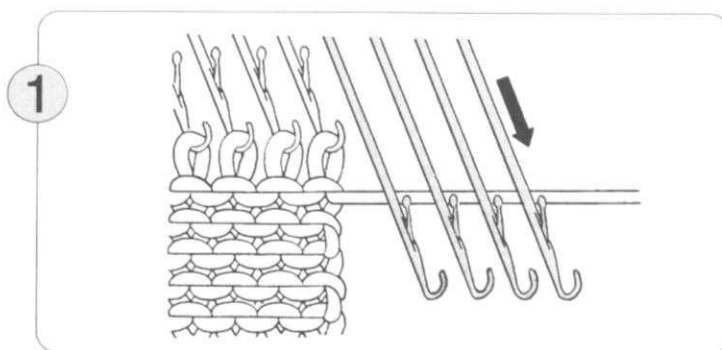

On the K-Carriage side, bring the needles to be increased forward from A position to E position.

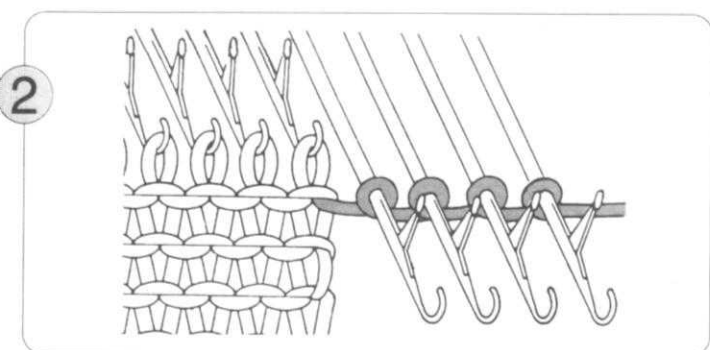

Wind the yarn loosely around the stem of each needle as shown.

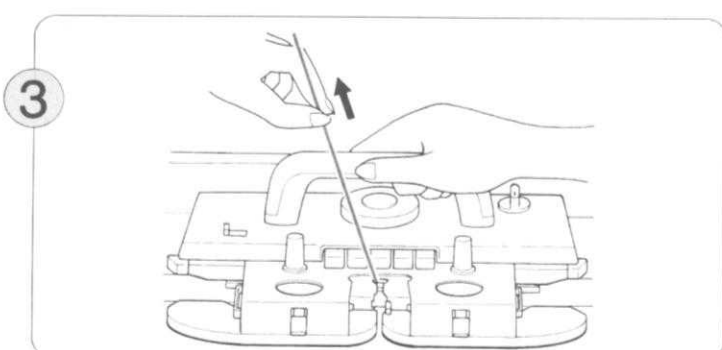

Pull up any loose yarn with your hand, and knit one row.

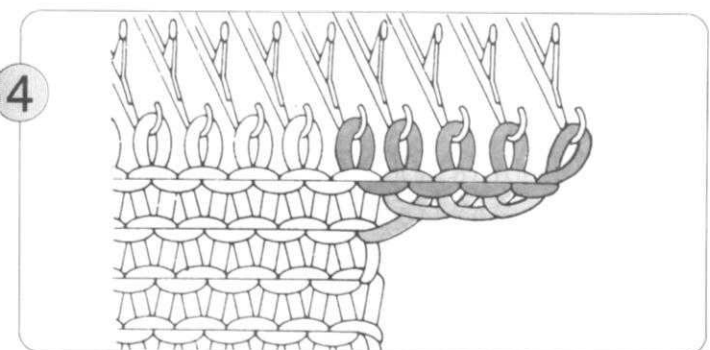

The needles in E position have knitted.

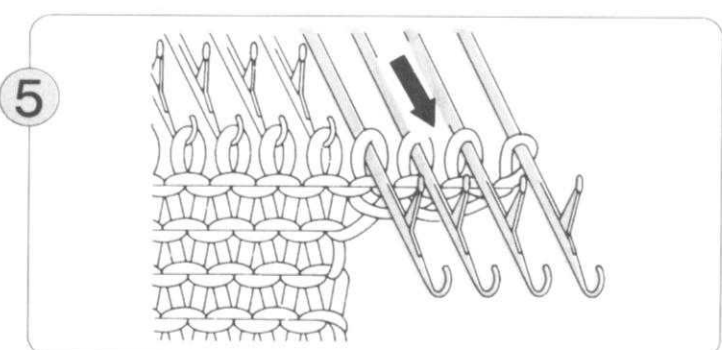

Pull the needles containing the new stitches to E position again, and knit one row. (This helps them to knit properly).

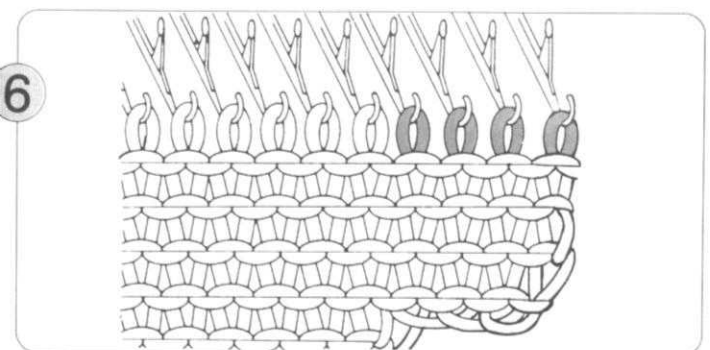

Knit two or three more rows in the same manner as Step ⑤, then continue knitting normally.



# 【 HOW TO DECREASE STITCHES 】

## ● Decreasing one stitch.

Simple method

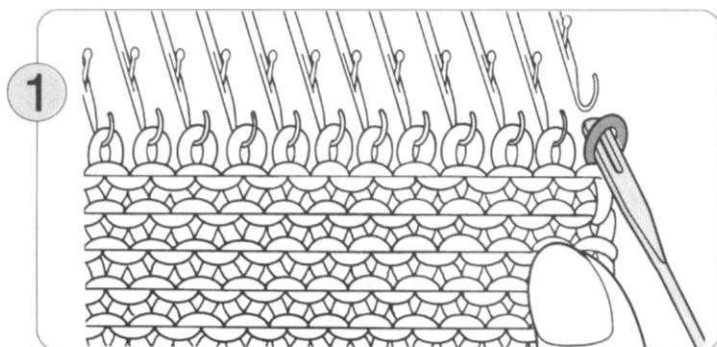

Remove one stitch at the edge onto your Transfer Tool.

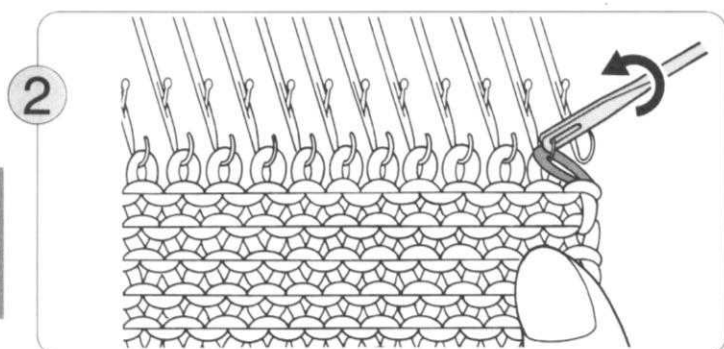

Place the Transfer Tool onto the hook of the adjacent inside needle, and transfer the stitch.

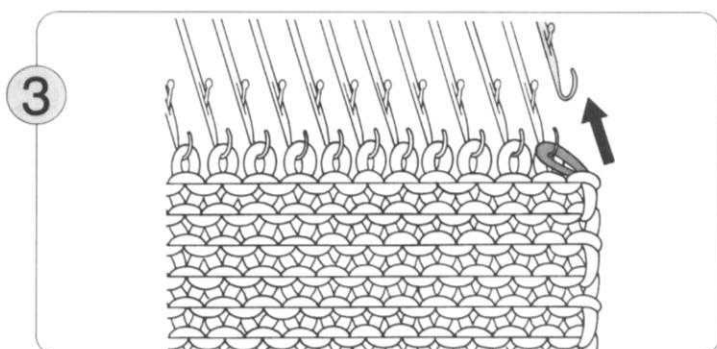

Return the empty needle to A position.

## Fully fashioned method

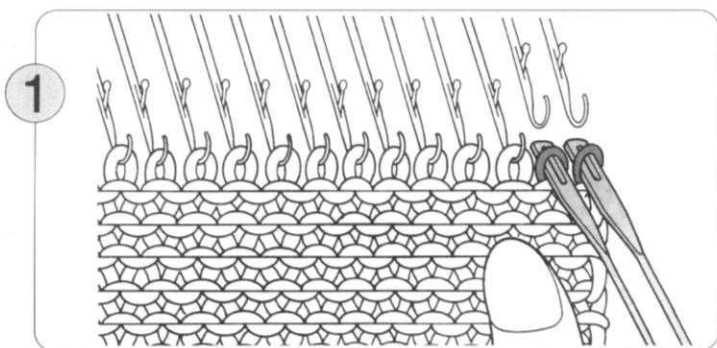

Remove two stitches at the edge using a 2 eyed Transfer Tool.

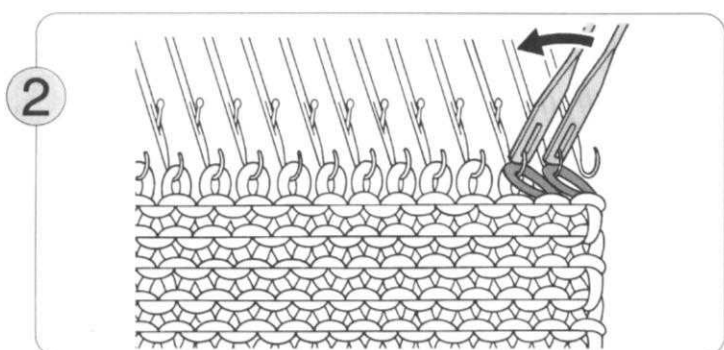

Place the Transfer Tool onto the hooks of the adjacent inside needles, and transfer the stitches.

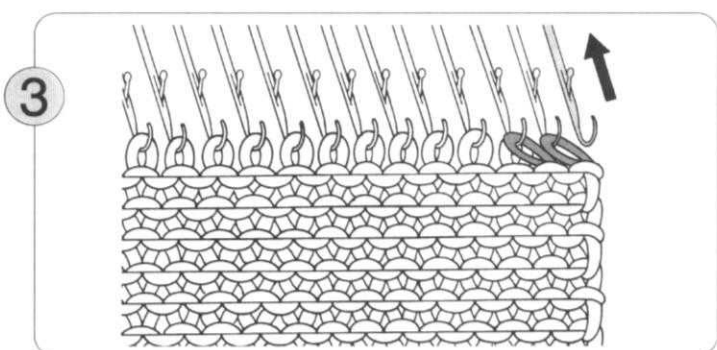

Return the empty needle to A position.

● **Decreasing several stitches**

The K-Carriage and yarn are at the side where you wish to decrease the stitches.

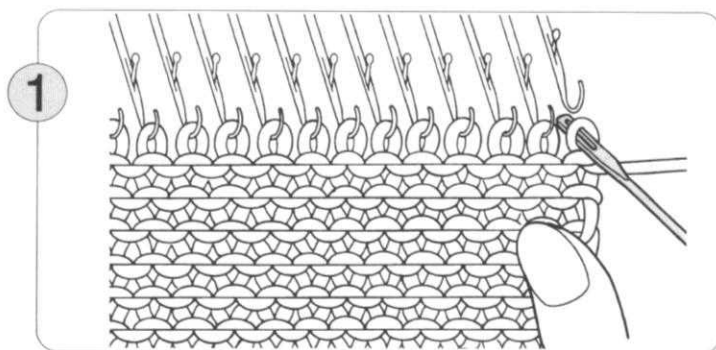

On the K-Carriage side transfer the end stitch onto the adjacent inside needle.

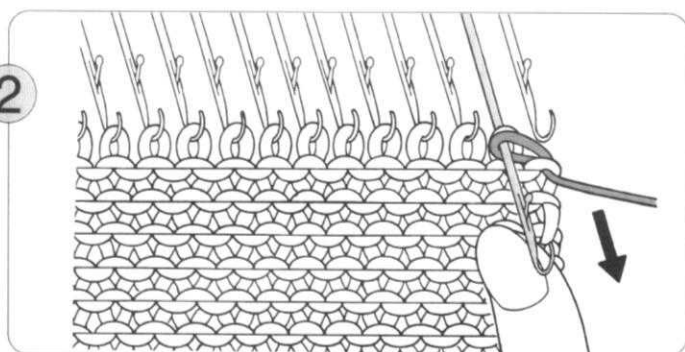

Bring this needle forward so that the two stitches are behind the latch.

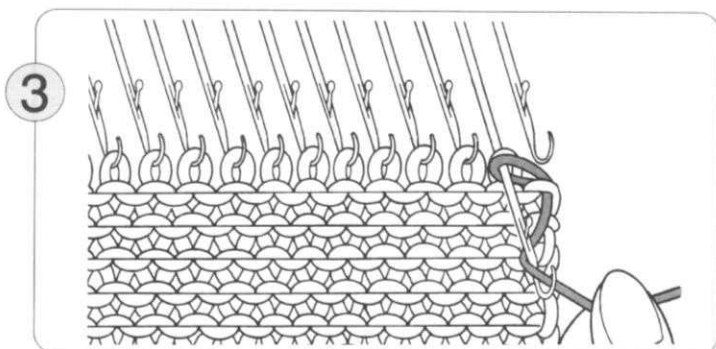

Loop the yarn around the needle hook in front of the latch as illustrated.

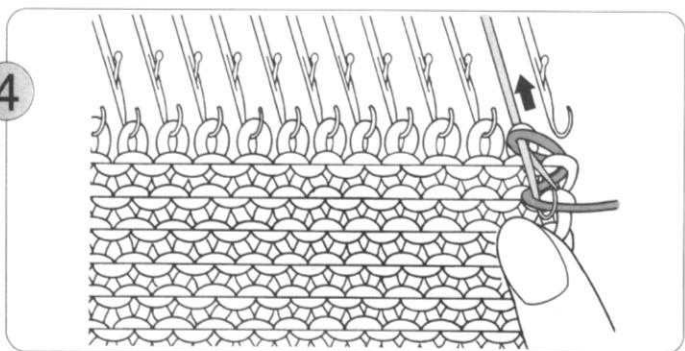

Manually push the needle back so that a single stitch is formed.

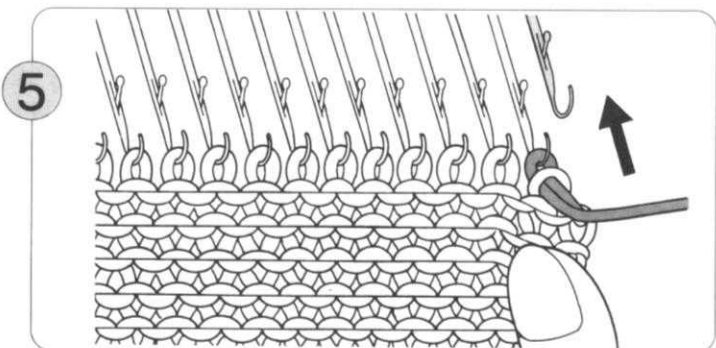

Return the empty needle to A position.

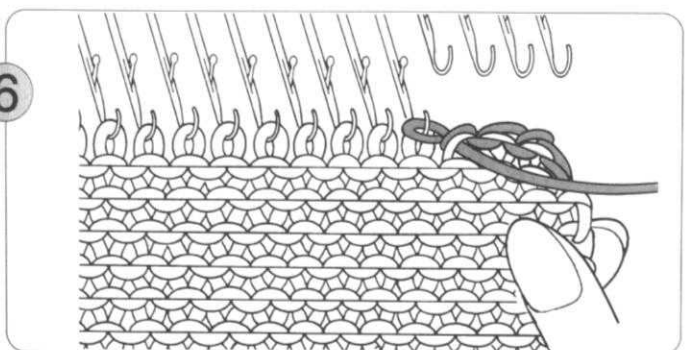

Repeat Steps ① – ⑤, but on the last stitch work Step ① only.

**NOTE:**

Take care not to make the stitches too tight.

# [ PARTIAL KNITTING ]

## 1. PLAIN STOCKING STITCH AND PATTERN KNITTING

### Decreasing stitches using the Holding Position (H.P)

- When working decreases for shoulders, neck opening etc., set the Holding Cam Lever on the K-Carriage to H.

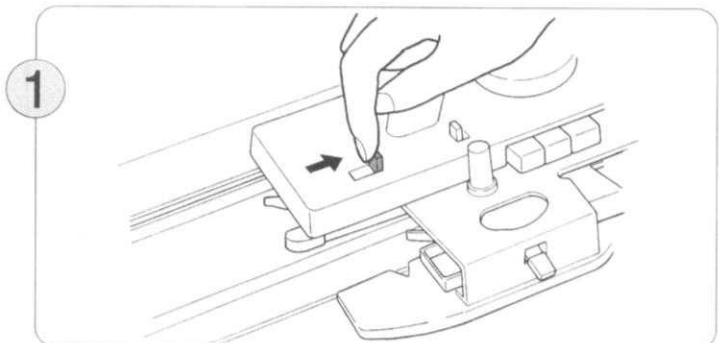
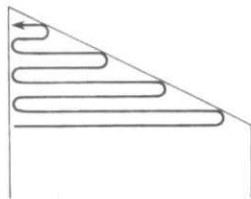

1 Set the Holding Cam Lever to H and the Cam Buttons and Change Knob according to the pattern.

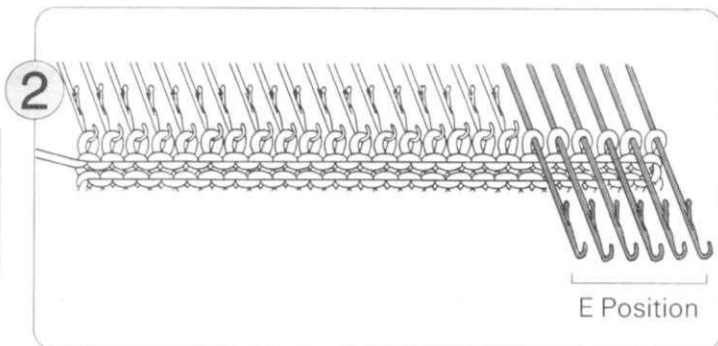

2 On the opposite side to the K-Carriage, bring the needles you want to decrease forward to E position.

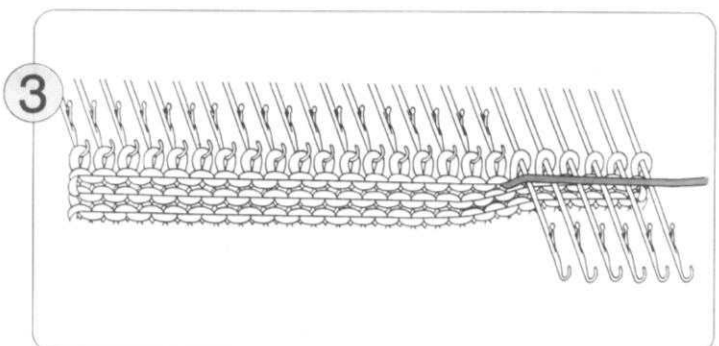

3 Knit one row. The needles in B position (B and D position in the case of pattern knitting) have been knitted and those in E position have not been knitted.

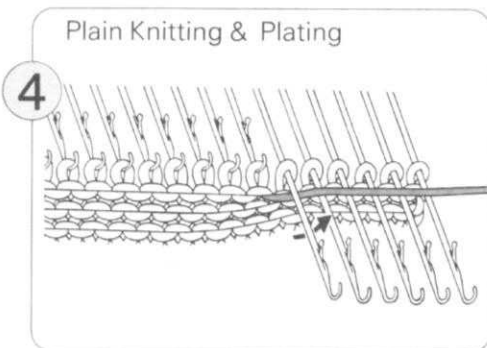

4 Wrap the yarn by passing it under the stem of the first needle in E position as shown.

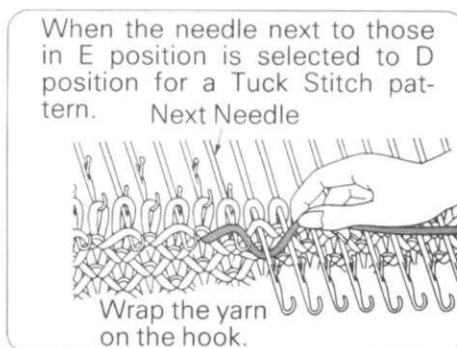

Wrap the yarn on the hook.

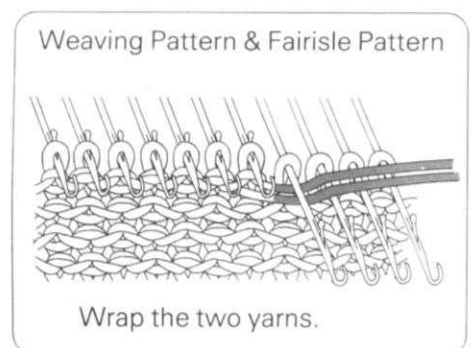

Wrap the two yarns.

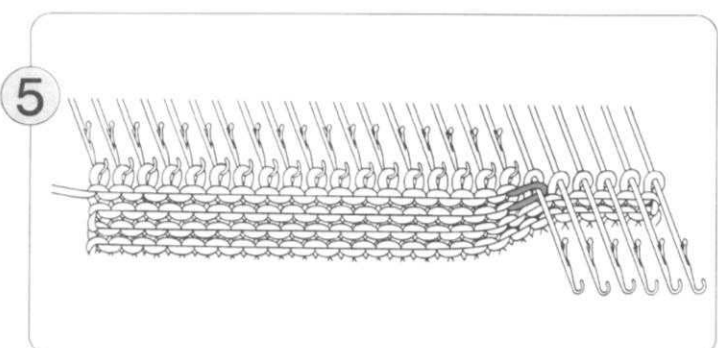

5 Pull up any loose yarn with your hand and knit one row. The yarn is wrapped around the end needle in Holding Position as shown above.

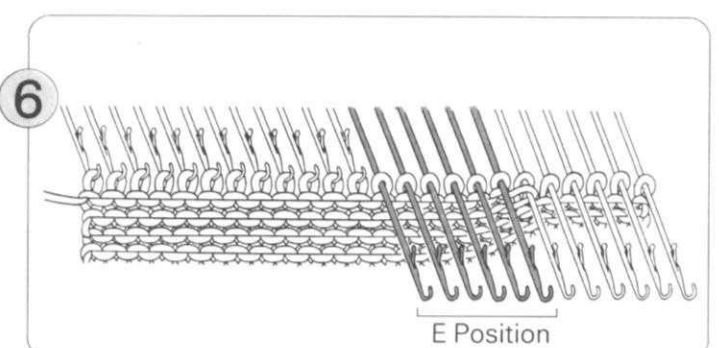

6 Continue moving needles to be decreased into E position, repeating Step 3 – 5.

♣ After partial knitting is complete, return the Holding Cam Lever to N.

## Increasing stitches from the Holding Position (H.P)

- When working increases (for example the hemline of a skirt), set the Holding Cam Lever to H.

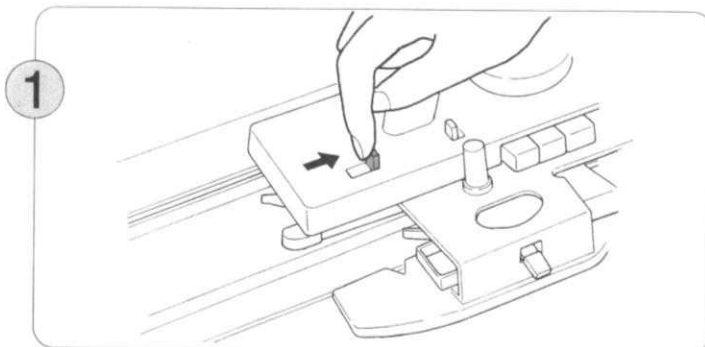
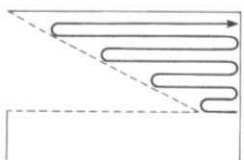

1 Set the Holding Cam Lever to H and the Cam Buttons and Change Knob according to the pattern.

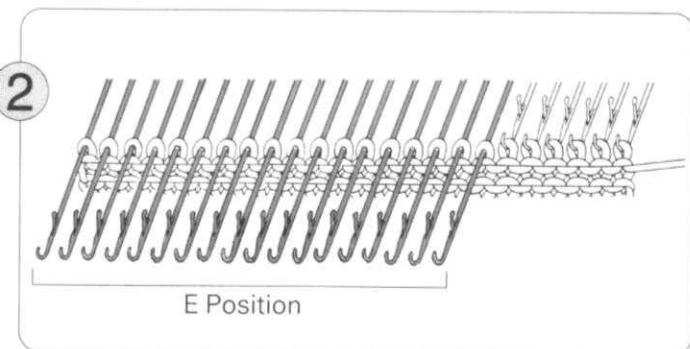

2 On the opposite side to the K-Carriage, bring forward to E position (H.P) those needles that you do not want to knit.

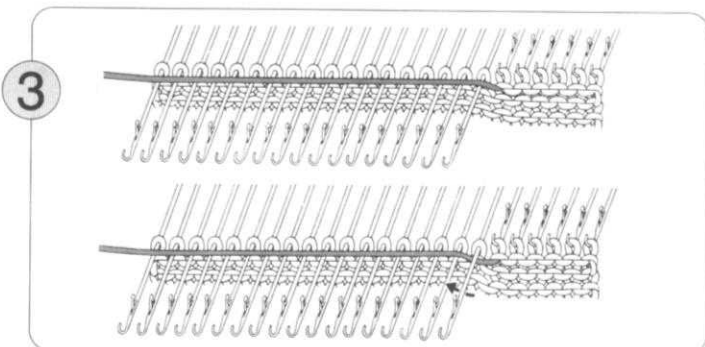

3 Knit one row. The needles in B position (B and D position in the case of pattern knitting) have been knitted, and the yarn has passed over those in E position. Wrap the yarn under the stem of the first needle in E position. (In the case of pattern knitting, refer to Step 4 on P.75).

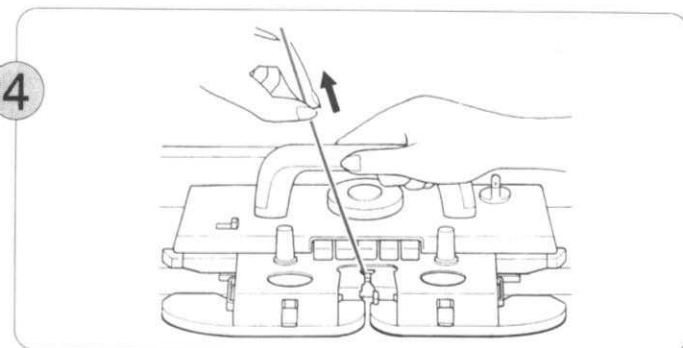

4 Pull up any loose yarn with your hand and knit one row.

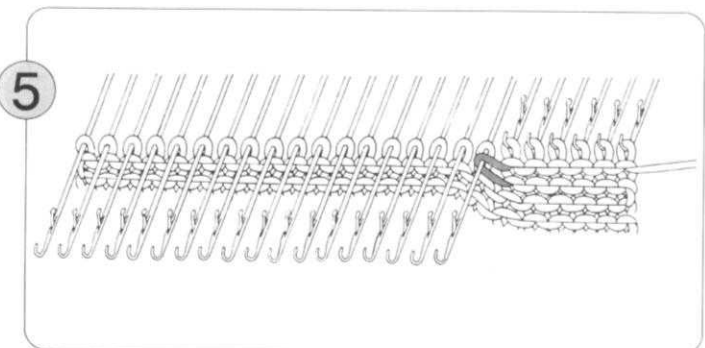

5 The yarn is wrapped around the end needle in Holding Position as shown above.

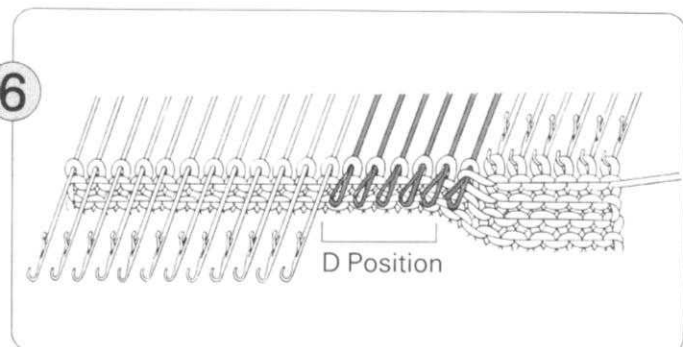

6 Manually push the needles to be increased from E to D position.

- ♣ For pattern knitting, put the appropriate needles to B position according to the pattern. When you return these needles from D to B position, place the stitches into the needlehooks using the Transfer Tool.

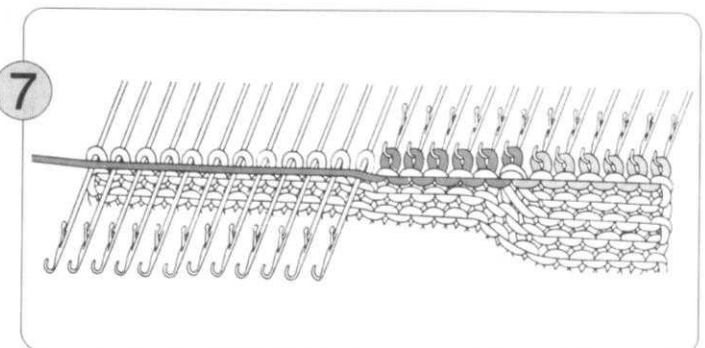

7 1) Knit one row and the needles you brought to D position will have been knitted.

2) Repeat Steps 3 - 6.

- ♣ After partial knitting is complete, return the Holding Cam Lever to N.



## 2. LACE OR FINE LACE PATTERN KNITTING

The method you use will depend on which side you work your partial knitting.

### Decreasing stitches

- **When you want to decrease on the righthand side...**

Move the K-Carriage to the left when the  mark comes to the card opening then start partial knitting.

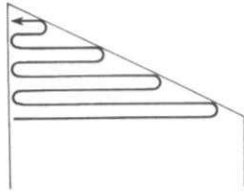

1

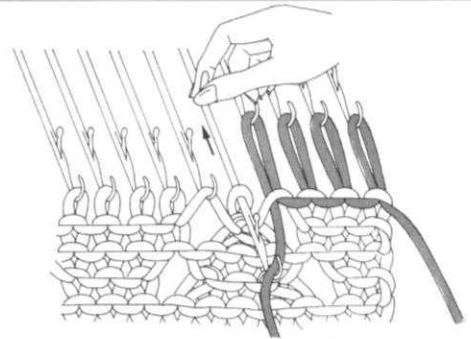

On the opposite side to K-Carriage manually knit the needles you want to decrease back to A position using the Cast-on Thread.

2

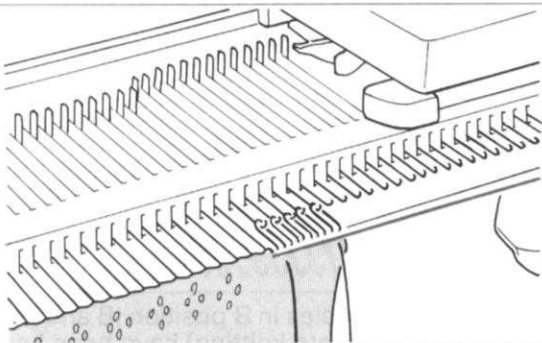

Knit one row with the K-Carriage.

3

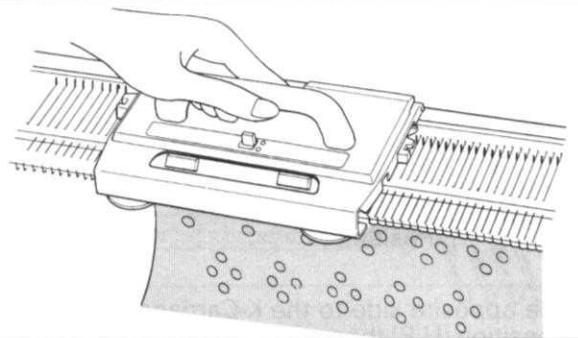

Operate the L-Carriage until the  mark comes to the card opening.

4

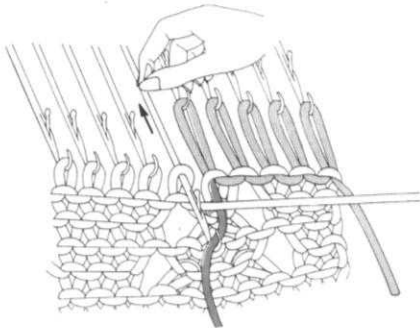

On the K-Carriage side, manually knit the next needles back to A position using the Cast-on Thread.

5

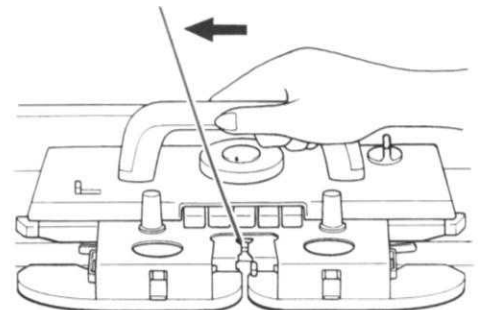

Knit one row with the K-Carriage.

6

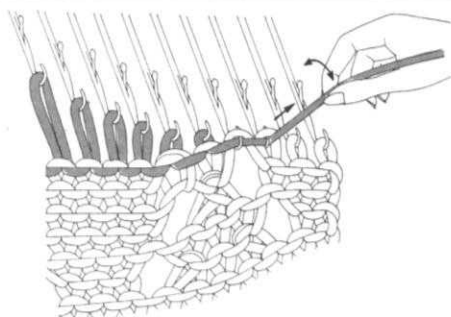

- **When you want to decrease on the left-hand side...**

Operate the L-Carriage until the  mark comes to the card opening, and then follow the Steps ①, ②, ④, ⑤, ③, ⑥ above.

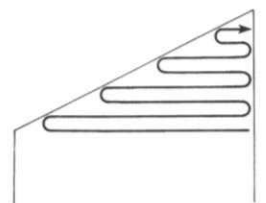

Repeat Steps ① – ⑥.

- ♣ After partial knitting, transfer the stitches in A position back into the hooks of the needles and remove the Cast-on Thread. Place needles in B position.

## Increasing stitches

- **When you want to increase on the righthand side...**

Move the K-Carriage to the left when the  mark comes to the card opening then start partial knitting.

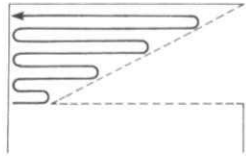

1

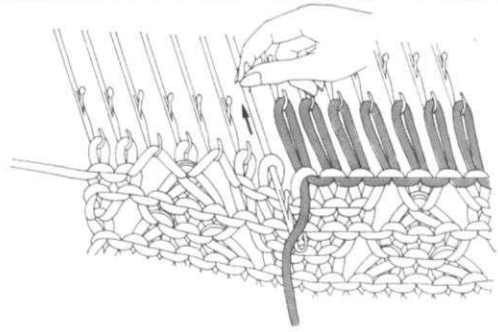

Using the Cast-on Thread, manually knit the needles you want to decrease back to A position.

2

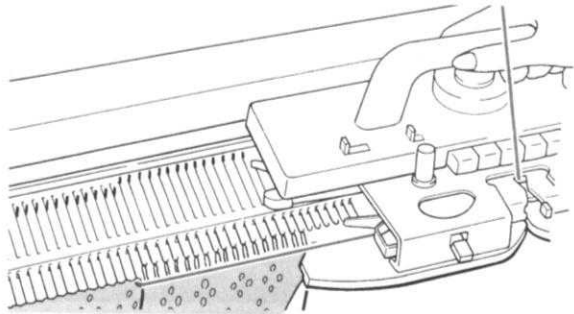

Knit one row with the K-Carriage.

3

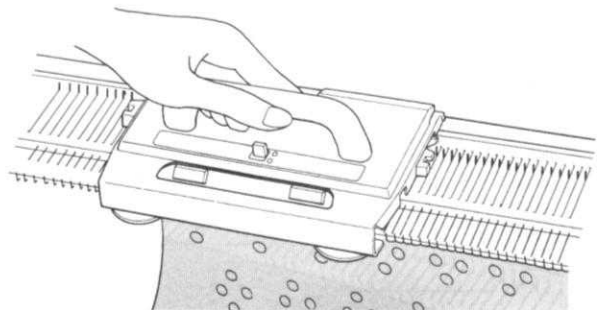

Operate the L-Carriage until the  mark comes to the card opening.

4

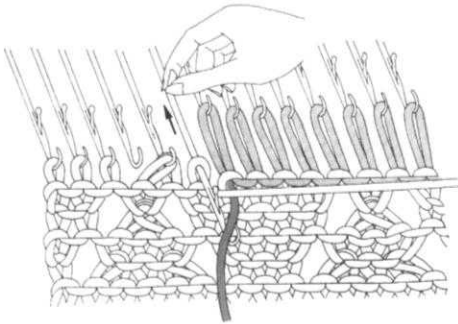

Manually knit the next needle back to A position using the Cast-on Thread.

5

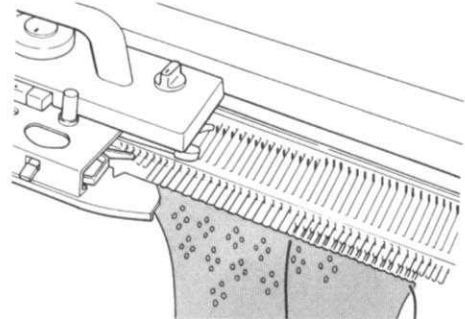

Knit one row with the K-Carriage.

6

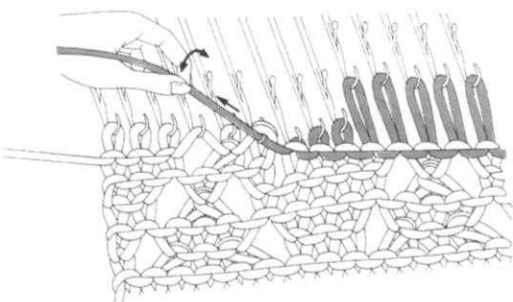

Transfer the first block of stitches in A position back into the hooks of the needles, removing the Cast-on Thread from these, and placing them in B position. Knit one row with the K-Carriage. Repeat Steps 3 – 6.

- **When you want to increase on the left-hand side...**

Operate the L-Carriage until the  mark comes to the card opening, and then follow the steps 1, 2, 4, 5, 3, 6 above.

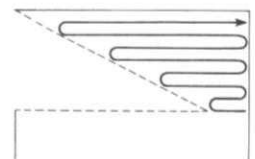

# [ HOW TO SHAPE A ROUND NECKLINE ]

## • STOCKING STITCH AND PLATING (USING THE HOLDING CAM LEVER)

- The following example begins with the yarn and K-Carriage at the left.  
Reverse the instructions (e.g. read left for right) if beginning with yarn and K-Carriage at the right.

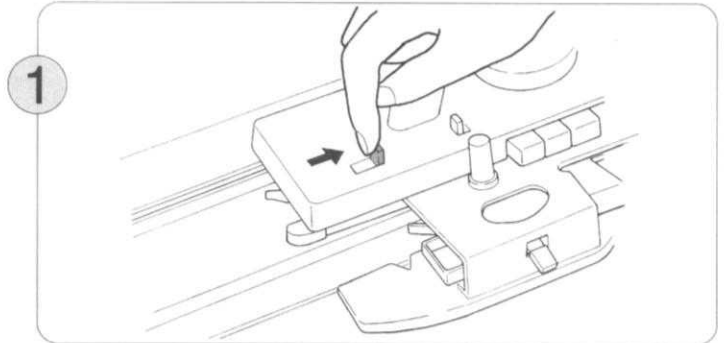
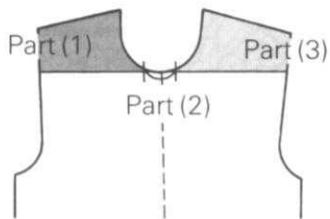

On the K-Carriage, set the Holding Cam Lever to H.

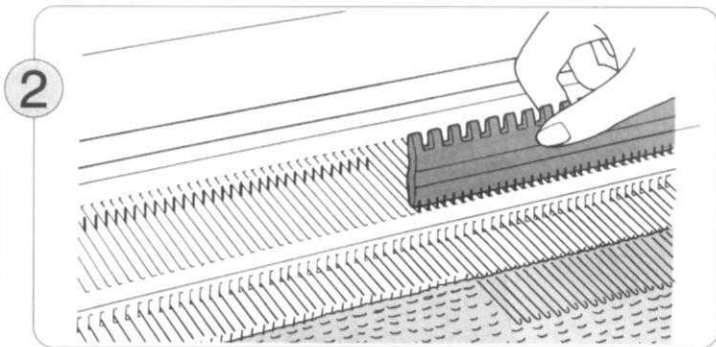

Using the flat side of the 1 x 1 Needle Pusher, bring the needles for Parts (2) and (3) forward to E position. These needles will not knit.

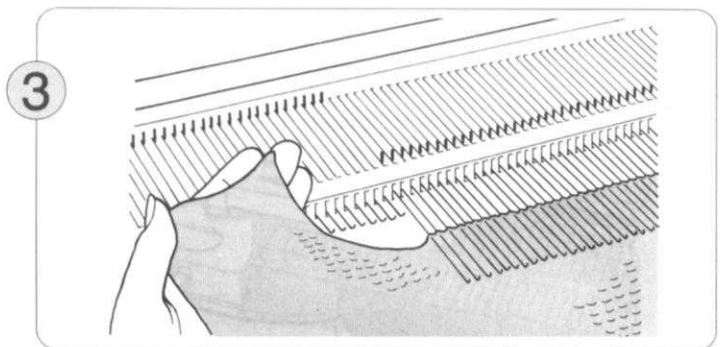

Knit Part (1) according to your pattern, and return needles to A position.

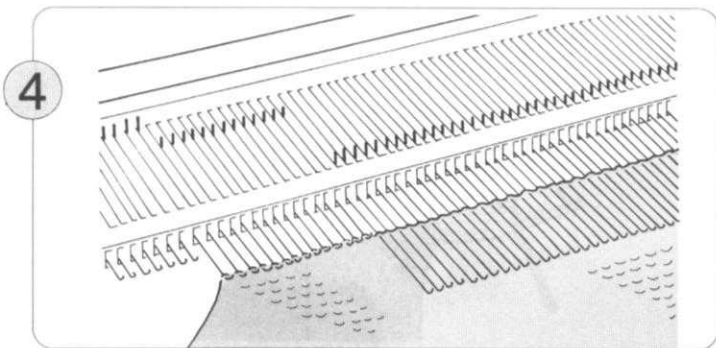

Bring needles from Part (2) to B position at the same time replacing the stitches into the needle hooks.

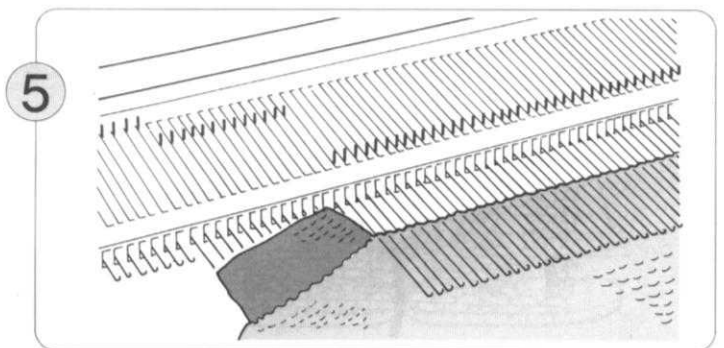

Waste knit Part (2) and remove this from machine. Return needles to A position.

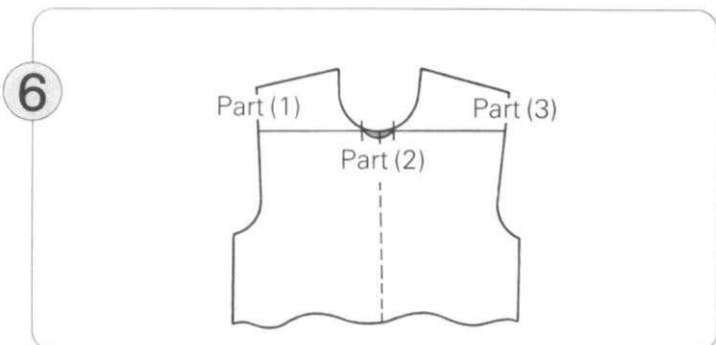

Now only the needles for Part (3) are left in E position.

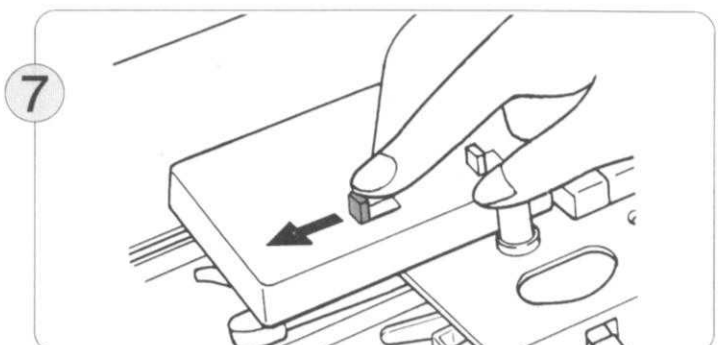

Set the Holding Cam Lever on the K-Carriage to N.

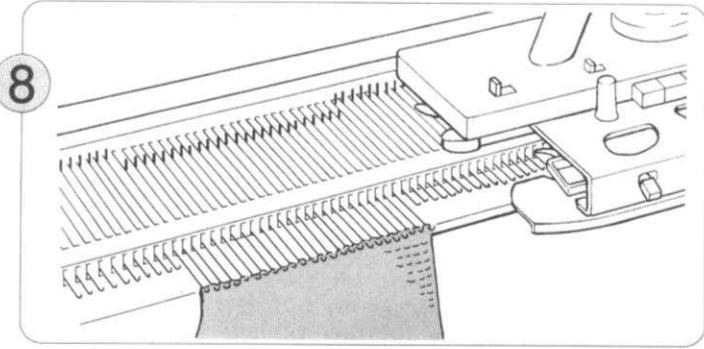

Knit Part (3) according to your pattern.

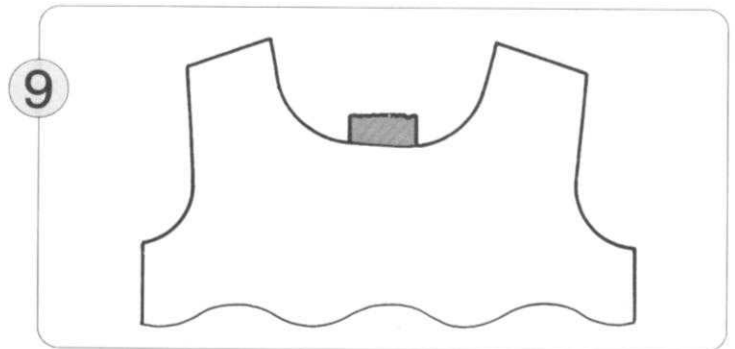

The neckline shaping has now been completed.

• **PATTERN KNITTING (USING THE HOLDING CAM LEVER)**

- The following example begins with the yarn and K-Carriage at the left. Reverse the instructions (e.g. read left for right) if beginning with yarn and K-Carriage at the right.

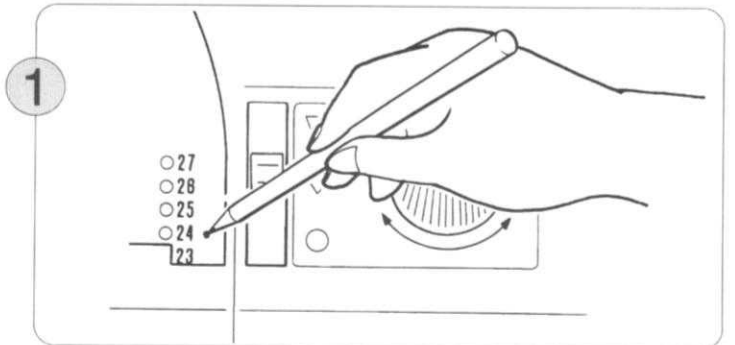
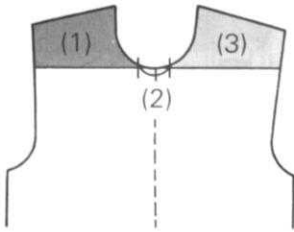

Before you start knitting part (1), mark on the Punch Card so that you can return to the exact row when you knit the other side.

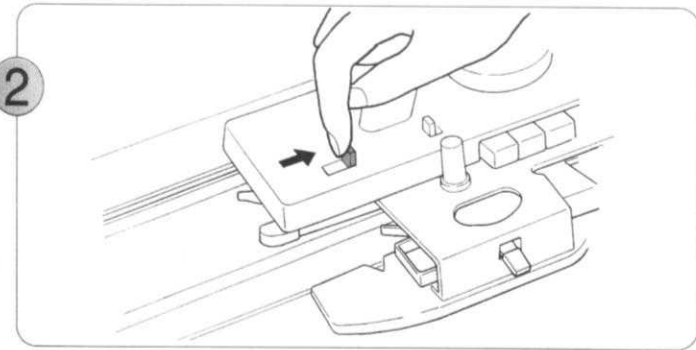

On the K-Carriage, set the Holding Cam Lever to H.

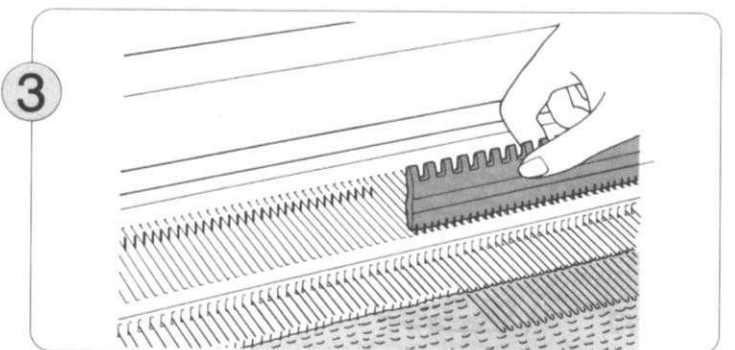

Using the flat side of the 1 x 1 Needle Pusher, bring the needles for Parts (2) and (3) forward to E position. These needles will not knit.

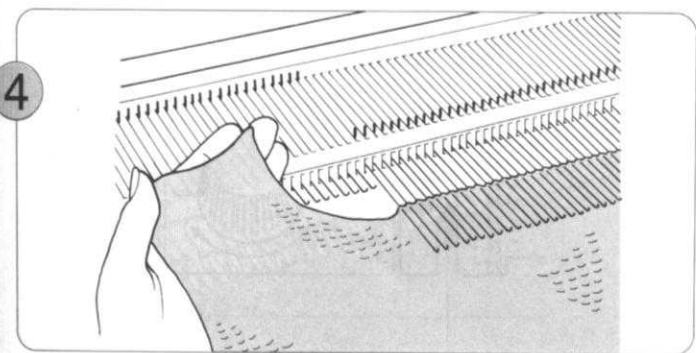

Knit Part (1) according to your pattern, and return needles to A position

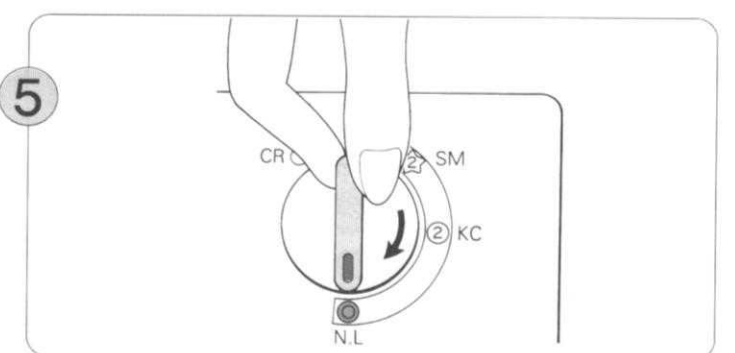

Set the Change Knob to N.L.



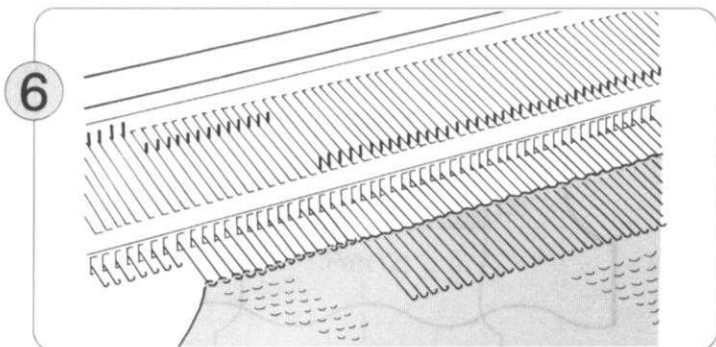

Bring needles from Part (2) to B position at the same time replacing the stitches into the needle hooks.

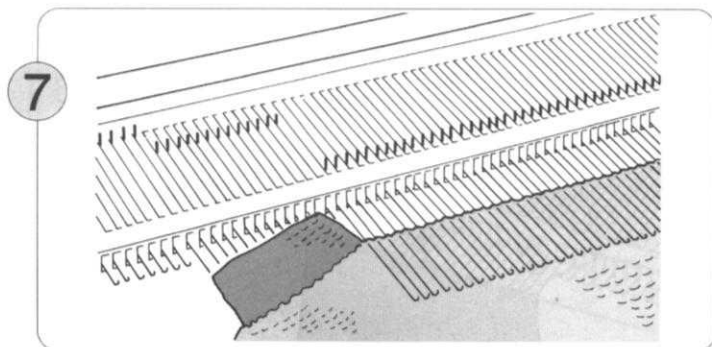

Waste knit Part (2) and remove this from machine. Return needles to A position.

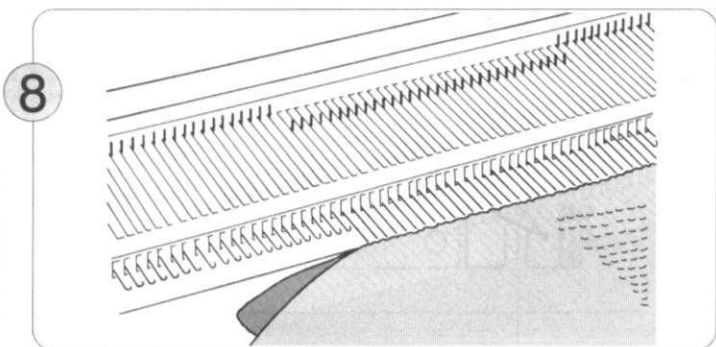

Now only the needles for Part (3) are left in E position. Bring these to B position the same as you did for Part (2).

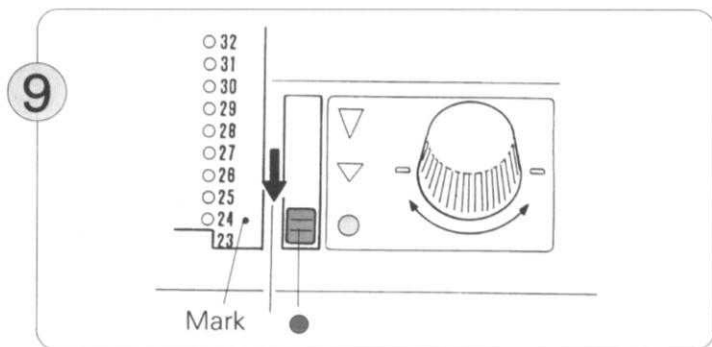

Wind the Punch Card back to the mark you made on it, and set the Card Lock Lever to "●" mark.

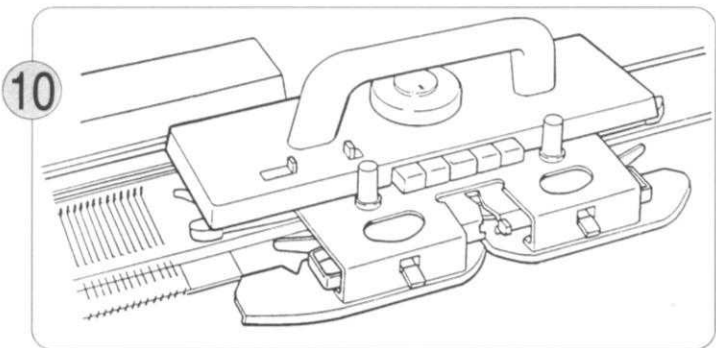

Place the K-Carriage on the right side of the machine.

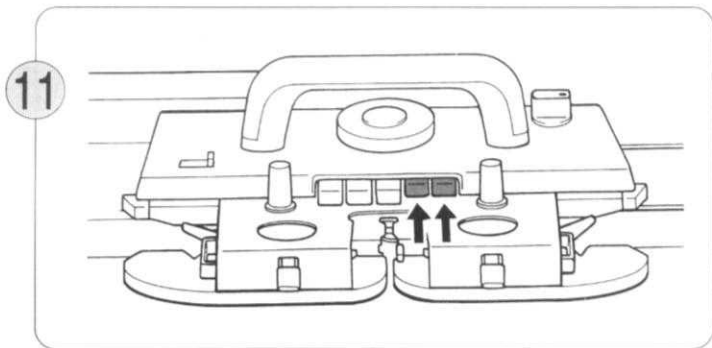

Push in both Part Buttons at the same time. Set the Change Knob to KC or SM.

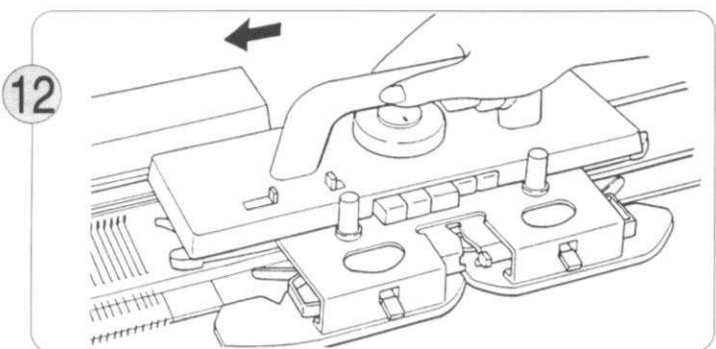

Move the K-Carriage from right to left without yarn. The needles are selected according to the pattern row.

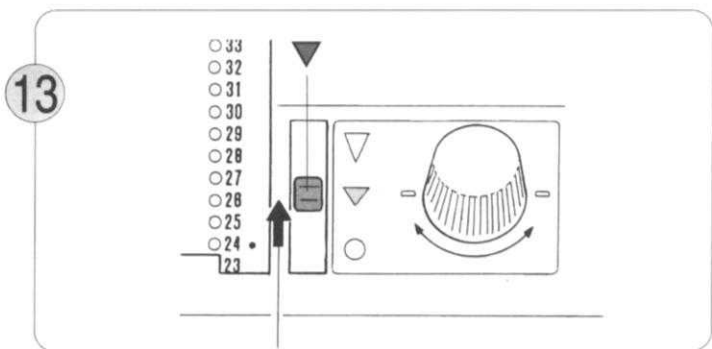

Set the Card Lock Lever at "▼" mark.

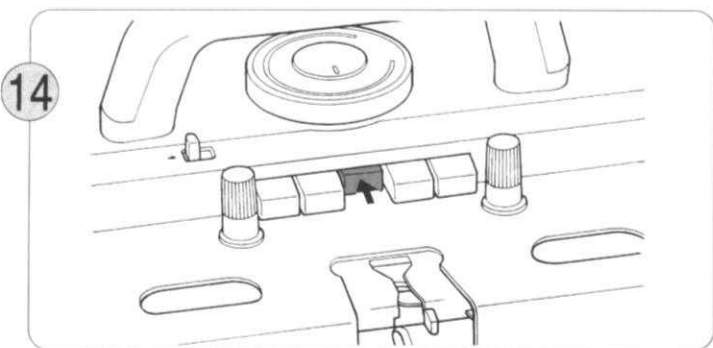

14 Push the Cam Buttons according to pattern. Thread up the yarn into Yarn Feeder. (If you are using contrast yarn, plating yarn or weaving yarn, don't forget to thread this up.)

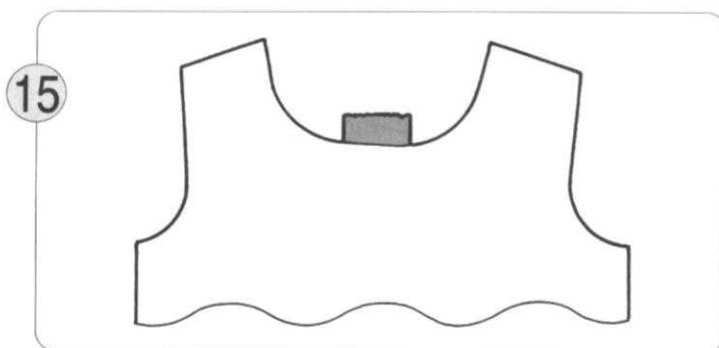

15 Knit Part (3) according to your pattern. The neckline shaping has now been completed.

### • LACE OR FINE LACE PATTERN

- When shaping a neckline in Lace Pattern, knit the right side first. If the yarn end is at the left, knit one more row so that the K-Carriage is at the righthand side.

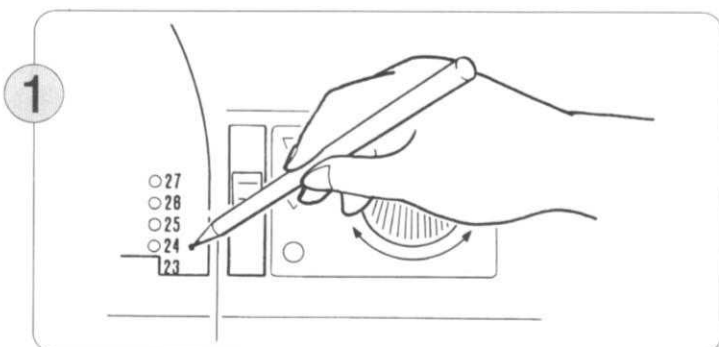
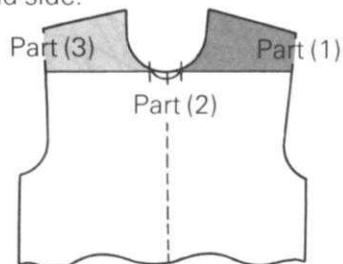

1 Before you start knitting Part (1), mark on the Punch Card so that you can return to the exact row when you knit the other side.

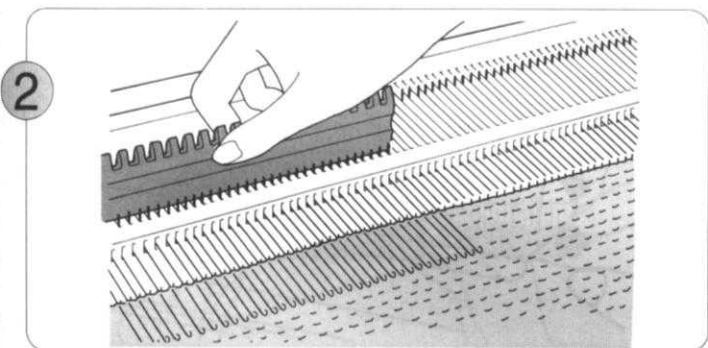

2 Using the flat side of the 1 x 1 Needle Pusher, bring the needles for Parts (2) and (3) forward to E position.

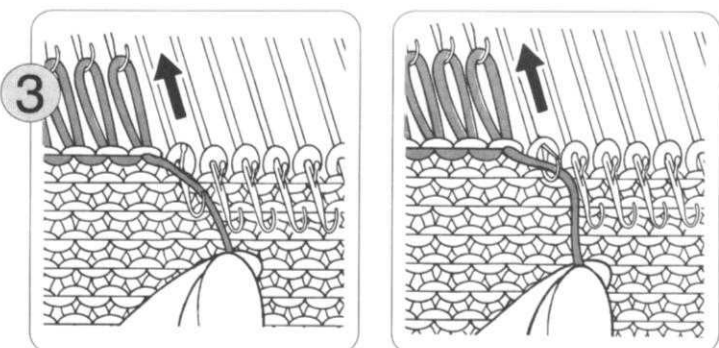

3 Hang the Cast-on Thread over the hooks of the needles in E position, and knit them back to A position by hand.

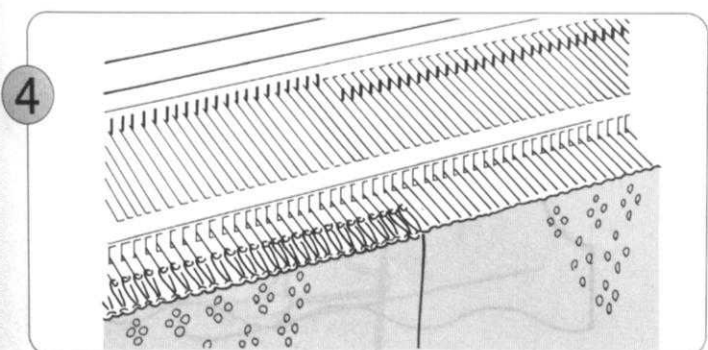

4 These needles in A position will not knit.

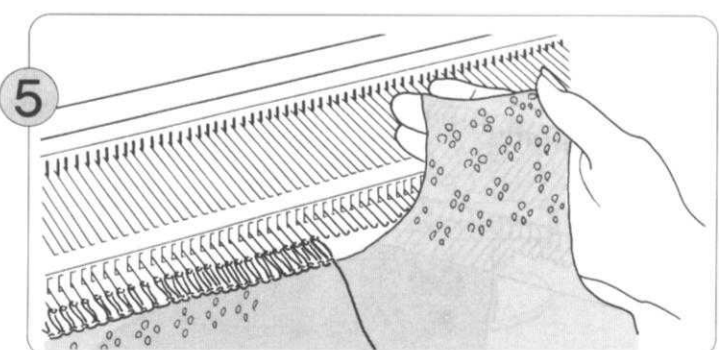

5 Knit Part (1) according to your pattern using both L and K-Carriages, and return empty needles to A position.

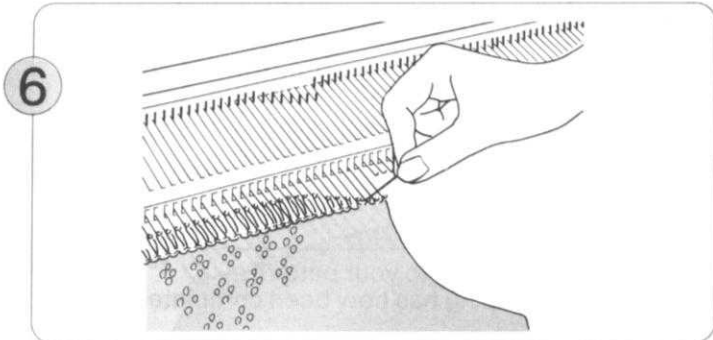

6 Bring needles from Part (2) from A to B position at the same time replacing the stitches into the needle hooks and removing the Cast-on Thread.

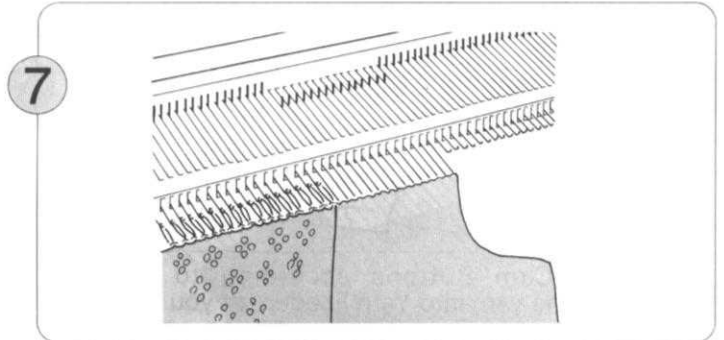

7 The needles for Part (3) are still left in A position.

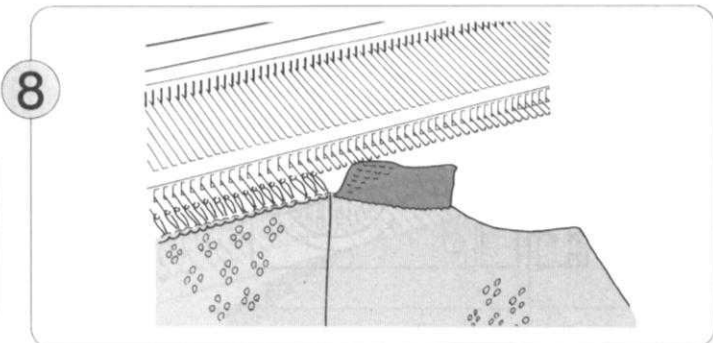

8 Knit Part (2) ending with waste knitting and remove this from machine. Return needles to A position.

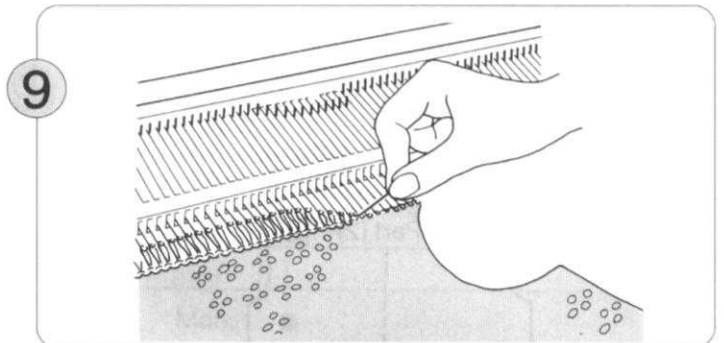

9 Now only the needles for Part (3) are left in A position. Bring these to B position the same as you did for Part (2).

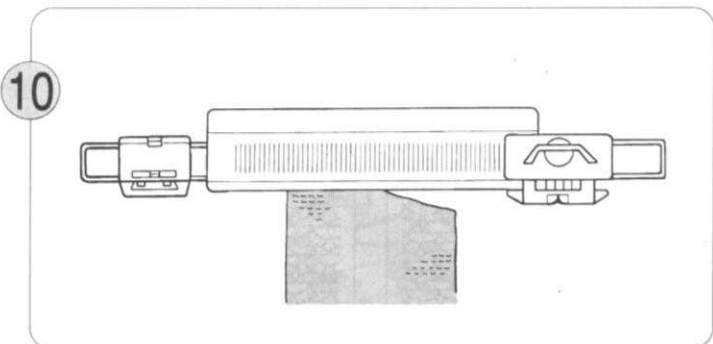

10 Place the K-Carriage on the right side of the machine and the L-Carriage on the left Extension Rail.

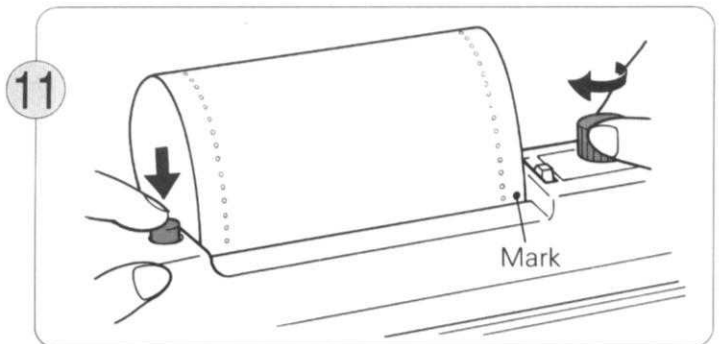

11 Wind the Punch Card back to the mark you made on it. (Leave the Card Lock Lever as it is "▽").

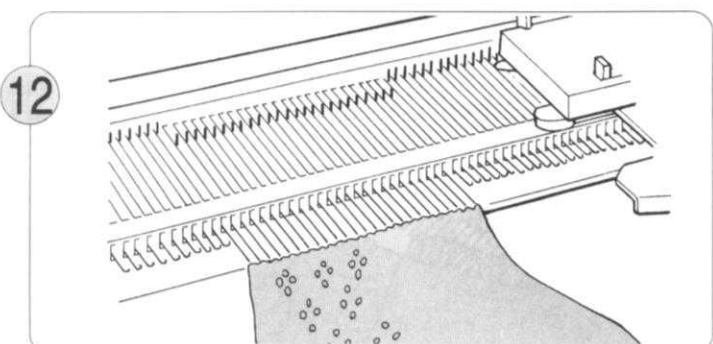

12 Knit Part (3) according to your pattern, using the K and L-Carriages.

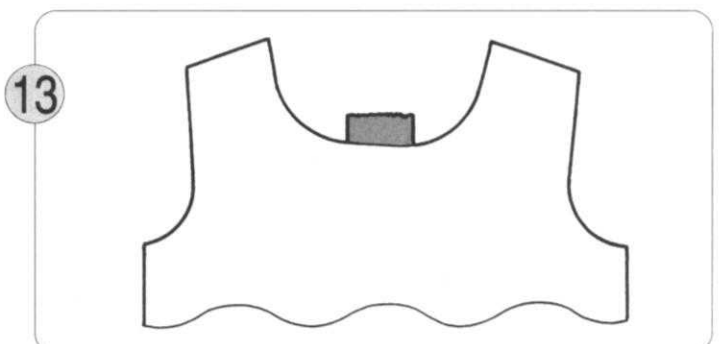

13 The neckline shaping has now been completed.

# [ HOW TO CAST ON WITH A FINISHED EDGE (CLOSED EDGE CAST ON) ]

## 'E' WRAP METHOD

- With this method you will achieve a thin, elastic edge so it is suitable for any type of knitting.

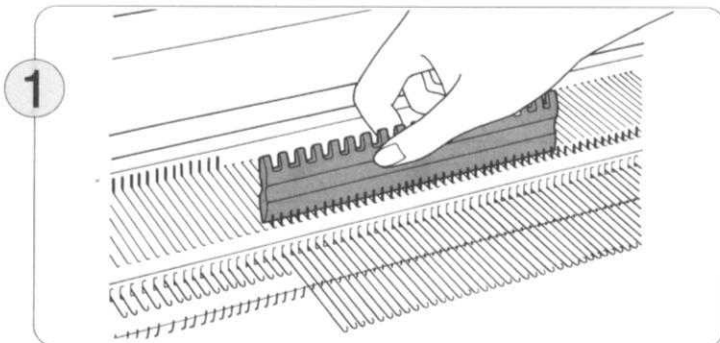
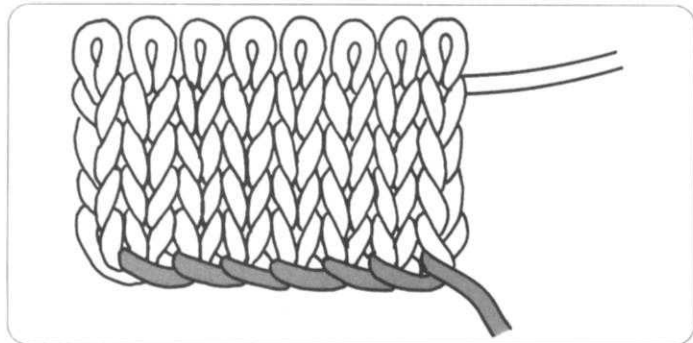

Place the K-Carriage at the right. Using the flat side of the 1/1 Needle Pusher, bring the needles forward to E position.

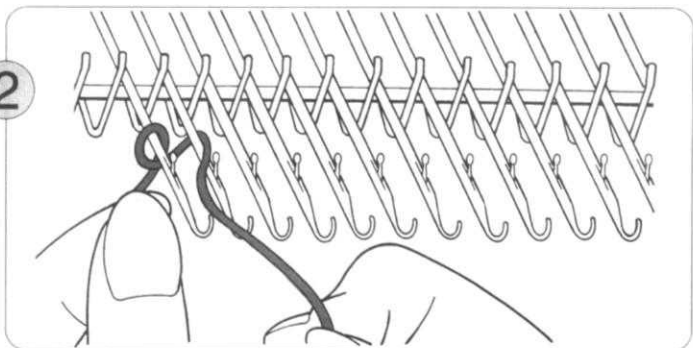

Beginning at the left, and working from left to right, wind the yarn around the needles in an anticlockwise direction. Do not wind the yarn too tight.

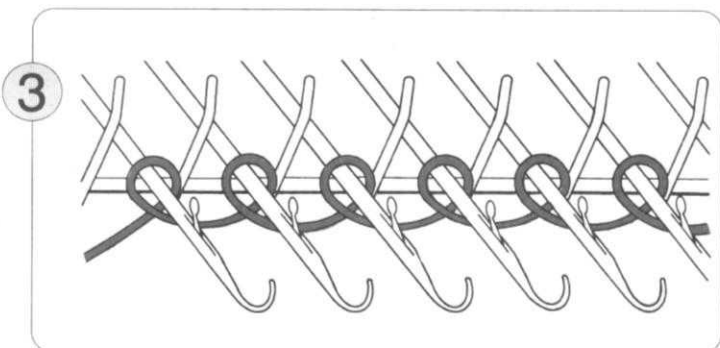

The loops should be behind the latches as shown.

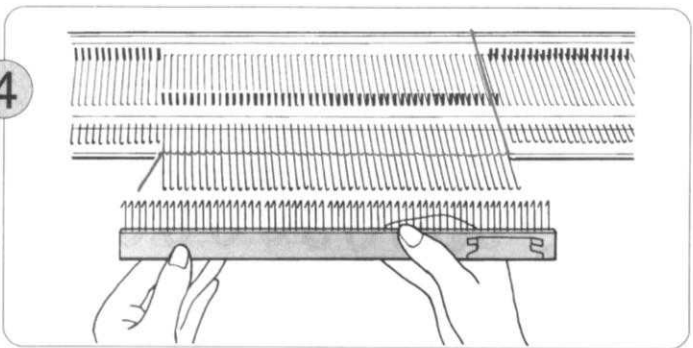

- (1) Take the Cast-on Comb out of the Case and choose the length according to the number of needles. (Refer to P.19).
- (2) Hold the Cast-on Comb as shown with the hooks facing the machine.

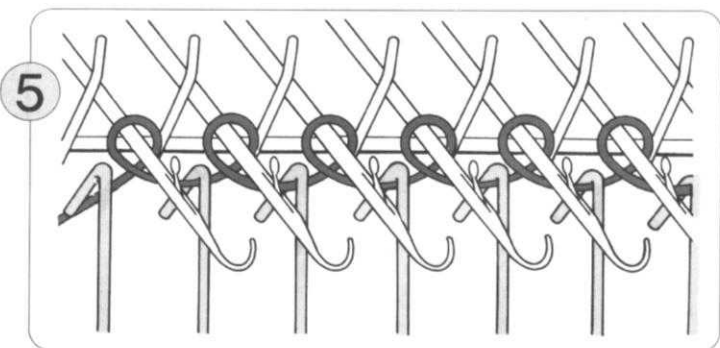

Pull the yarn through the edge hook. Hang the Cast-on Comb over the loops and gently pull it downwards.

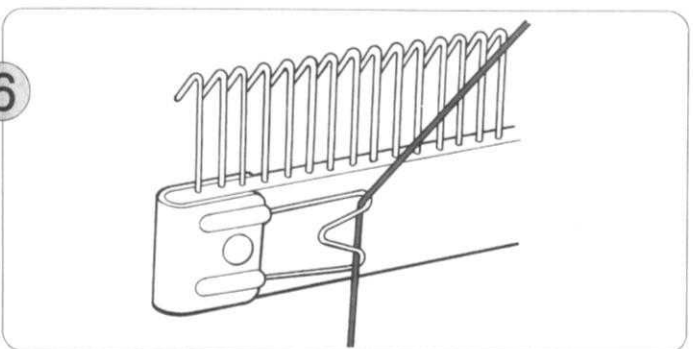

Hook the loose yarn end under the yarn Clip from the front.

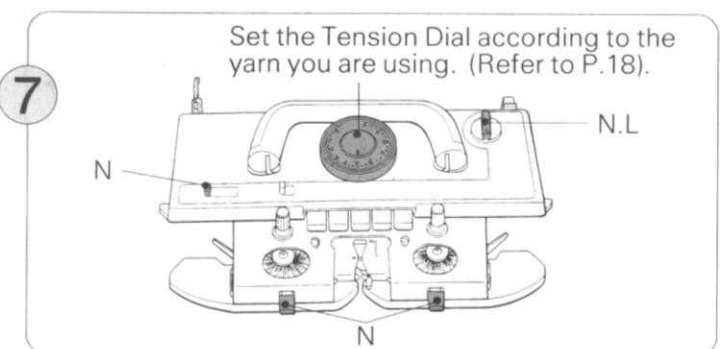

Set the Tension Dial according to the yarn you are using. (Refer to P.18).

Set the K-Carriage as shown above.



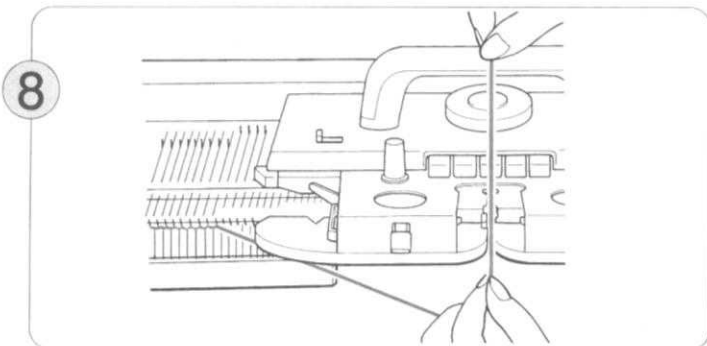

8 Thread the yarn into Yarn Feeder "A" (Refer to Steps ⑤ – ⑦ on P.24).

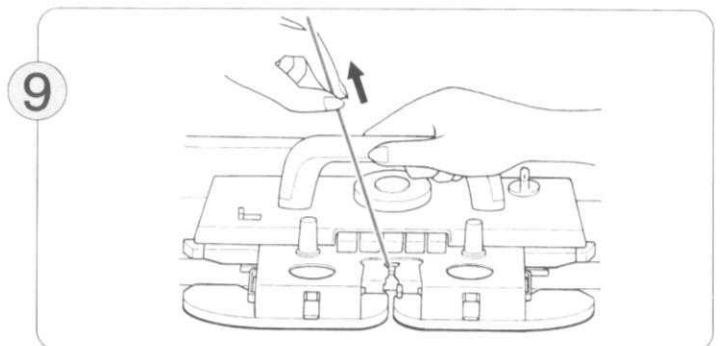

9 Move the K-Carriage to the left, holding the yarn as shown so that no loops are formed.

## USING THE LATCHET TOOL

- With this method you will achieve a firm edge which is not very elastic.

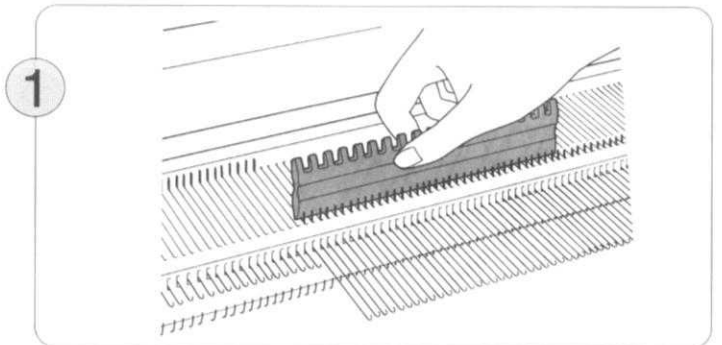
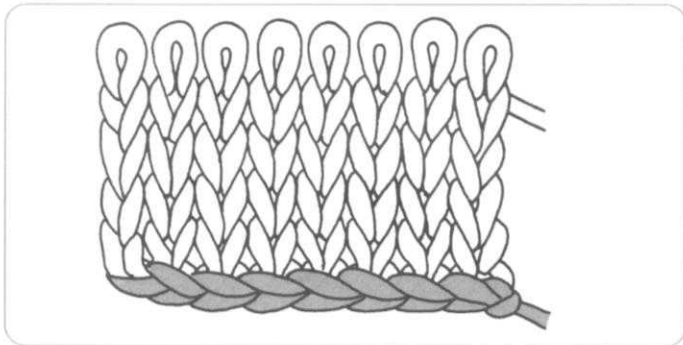

1 Place the K-Carriage at the right. Using the flat side of the 1/1 Needle Pusher bring the needles forward to E position.

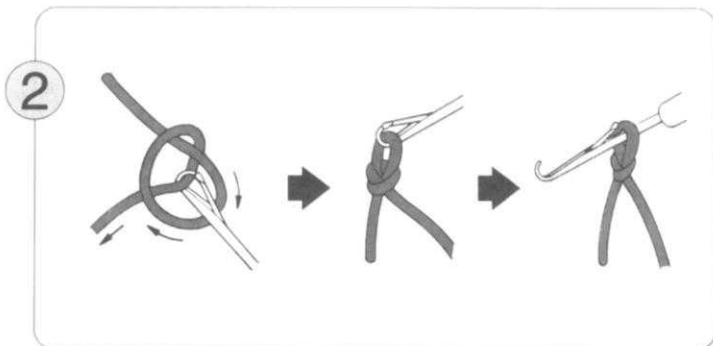

2 Thread the yarn into the Yarn Tension Unit. Now make a chain stitch using the Latchet Tool as shown.

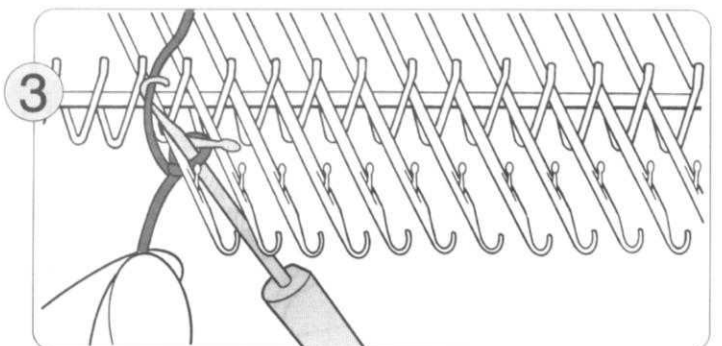

3 With the loop behind the latch, insert the Latchet Tool between the first and second needles on the left. Catch the yarn with the Latchet Tool.

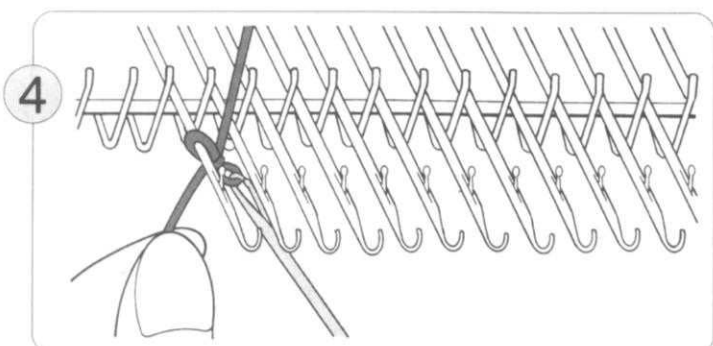

4 Keeping the yarn in the hook of the Latchet Tool, pull the yarn down through the chain loop, and slip the loop off the Latchet tool. This makes one stitch.

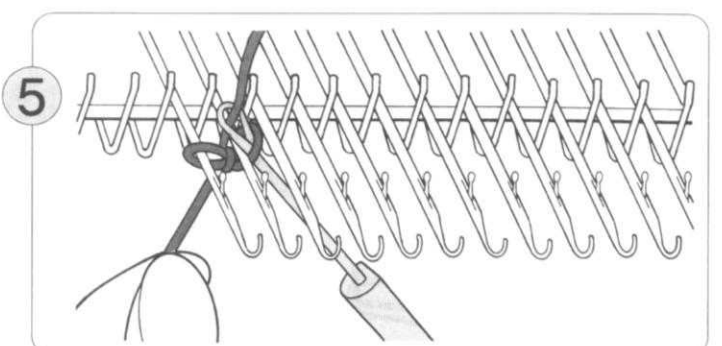

5 Repeat this across the needles until you reach the last needle.

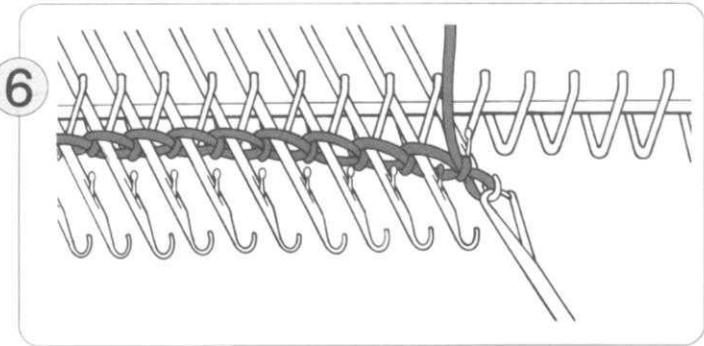

6 When you get to the last needle, transfer the loop from the Latchet Tool into the needle hook.

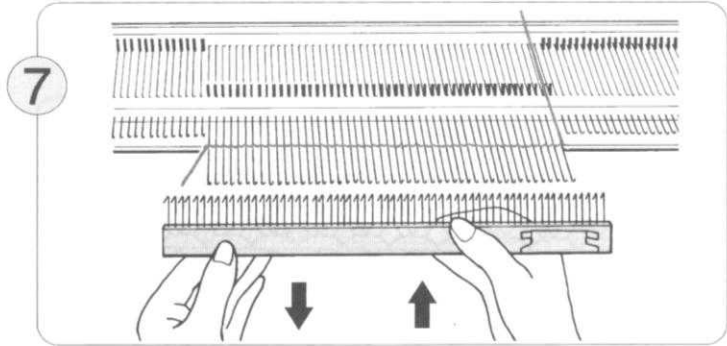

7 (1) Take the Cast-on Comb out of the Case and choose the length according to the number of needles. (Refer to P.19).  
 (2) Hold the Cast-on Comb as shown with the hooks facing the machine. Hang the Cast-on Comb over the loops and gently pull it downwards.

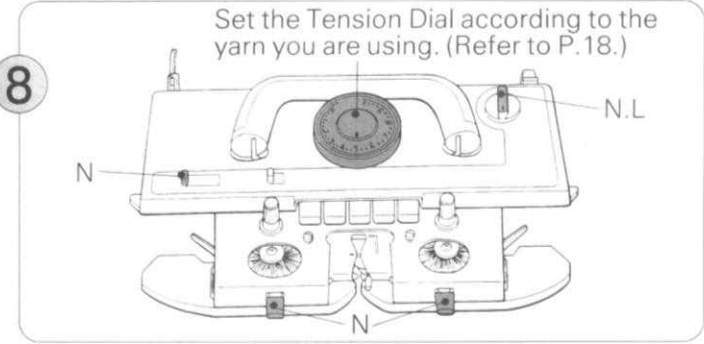

8 Set the Tension Dial according to the yarn you are using. (Refer to P.18.)

Set the K-Carriage as shown above.

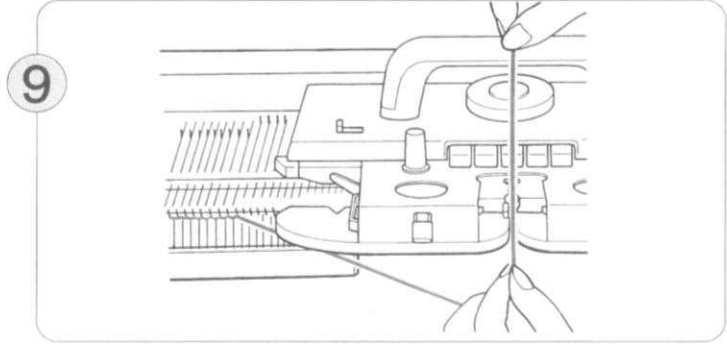

9 Thread the yarn into Yarn Feeder "A". (Refer to Steps 5 - 7 on P.24).

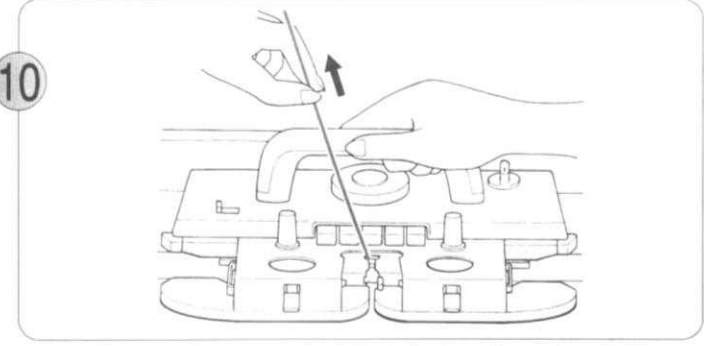

10 Move the K-Carriage to the left, holding the yarn as shown so that no loops are formed.

# USING THE WEAVING PATTERN LEVER

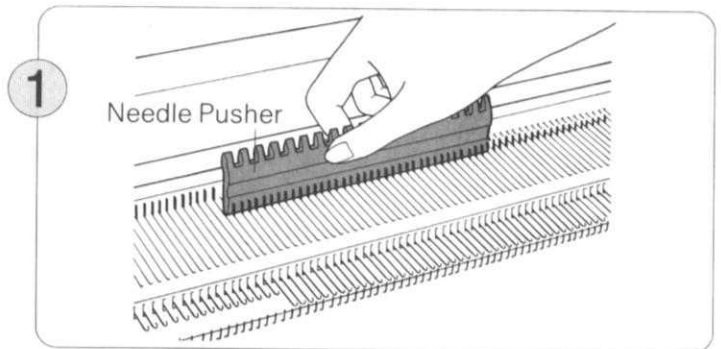
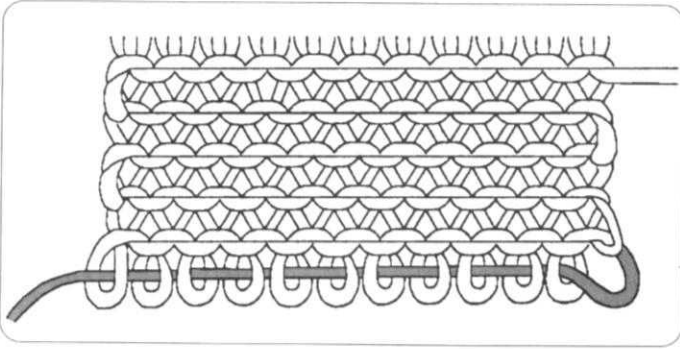

1 Place the K-Carriage at the right. Using the flat side of the 1/1 Needle Pusher, bring the needles forward to B position.

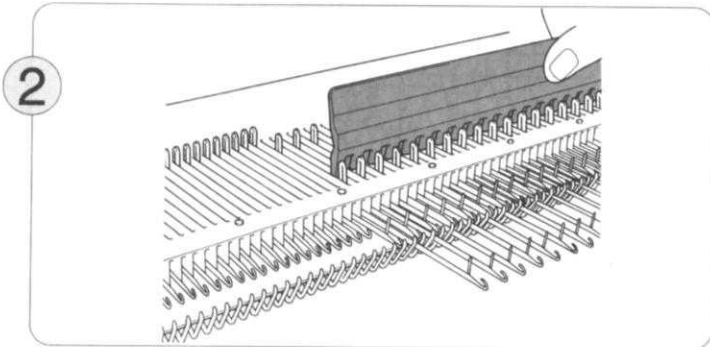

2 Using 1/1 NEEDLE PUSHER, bring forward every other needle to E position.

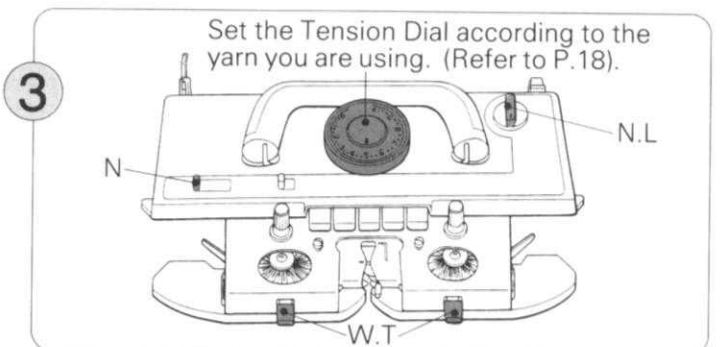

3 Set the K-Carriage as shown above.

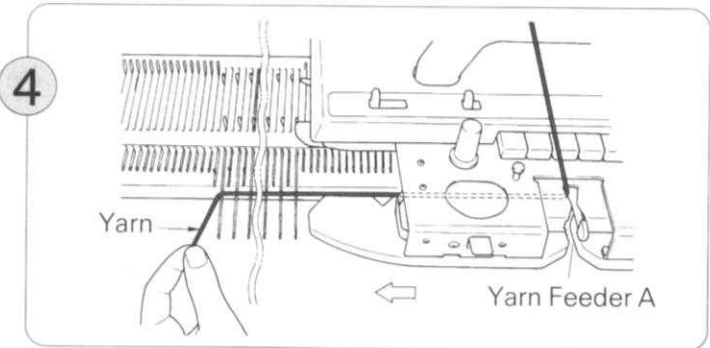

4 Thread the yarn into the yarn feeder "A". Holding the end of the yarn with your left hand, lay the yarn over the selected needles as shown. Hold the end of the yarn as shown in the figure.

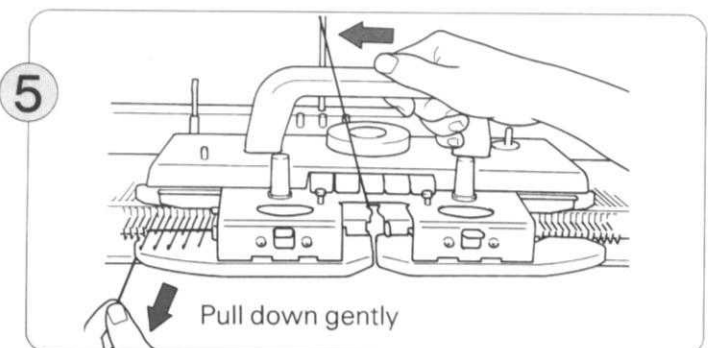

5 Pulling the yarn down gently with the left hand, move the K CARRIAGE to knit slowly with right hand. Continue to hold the end of yarn with left hand for few rows.

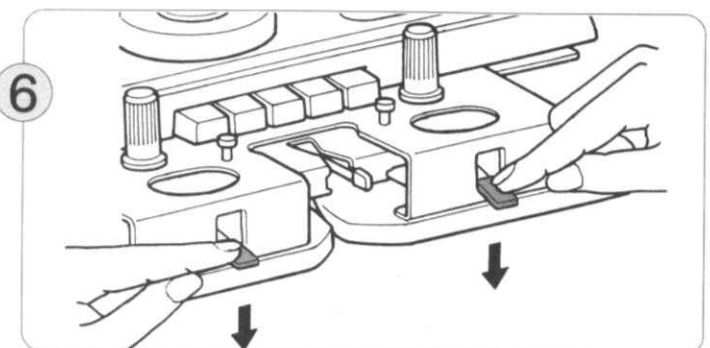

6 Release yarn which was held in left hand, and return the Weaving pattern levers to N.

## WASTE KNITTING (CASTING-ON)

- Waste knitting is the term used to describe knitting that will be removed when the garment is completed, or to enable you to carry out the next step.

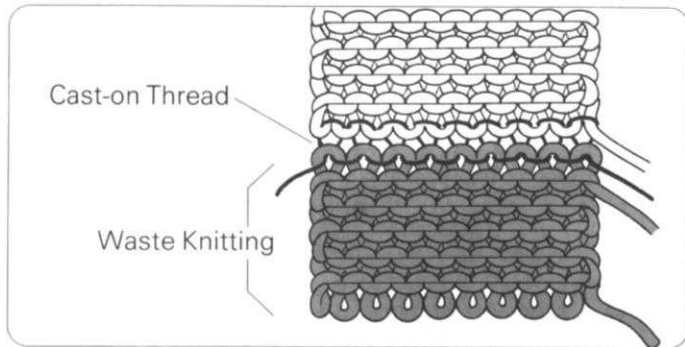

Waste yarn is a smooth yarn in a different colour to that of the main yarn.

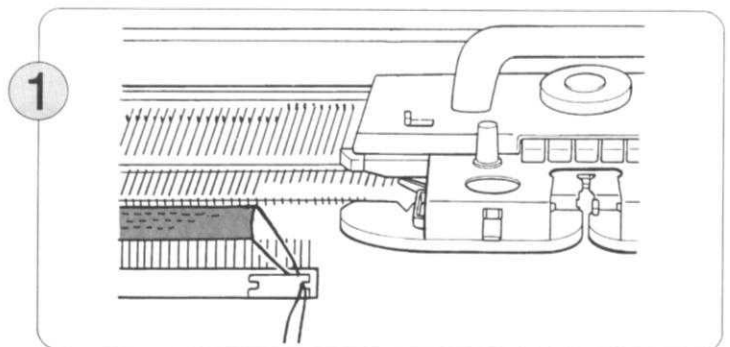

1 Knit about 10 rows in stocking stitch using waste yarn ending with the K-Carriage at the right of the needle bed. Remove waste yarn from Yarn Feeder and cut the yarn.

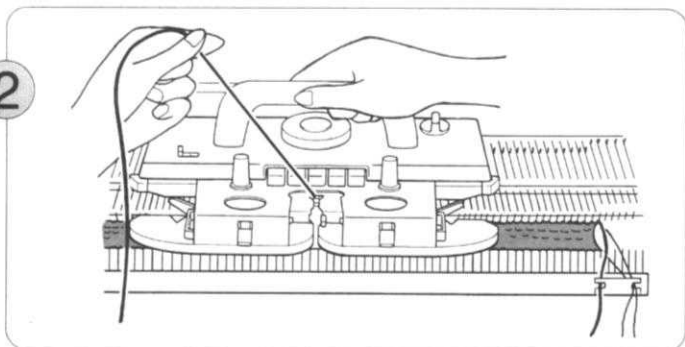

2 Thread the Cast-on Thread into Yarn Feeder "A". Hold the end as shown and knit one row. Remove Cast-on Thread from Yarn Feeder "A".

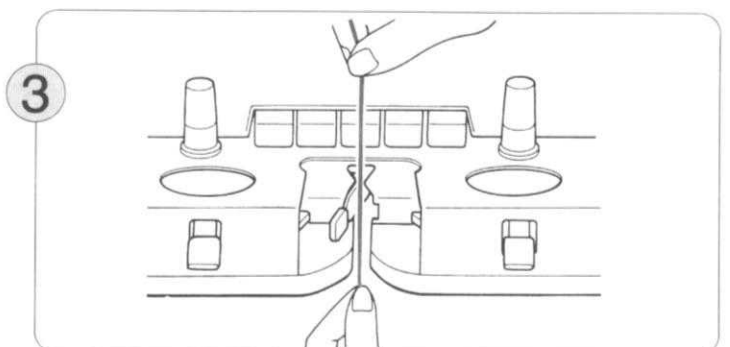

3 Thread the main yarn into Yarn Feeder "A".

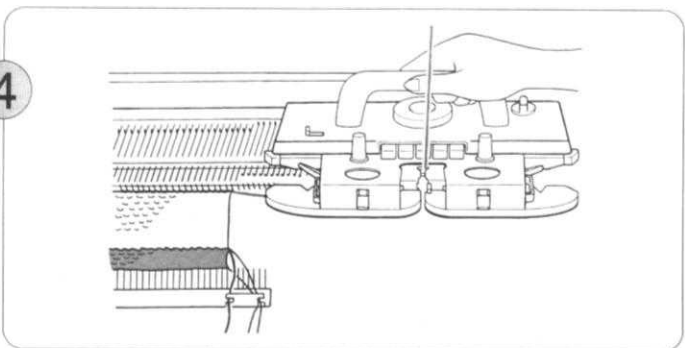

4 Knit several rows.

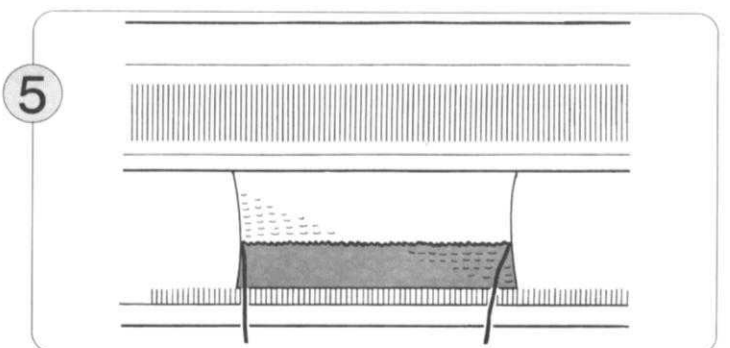

5 One row has been knitted with the Cast-on Thread and this separates the waste knitting from the main knitting.

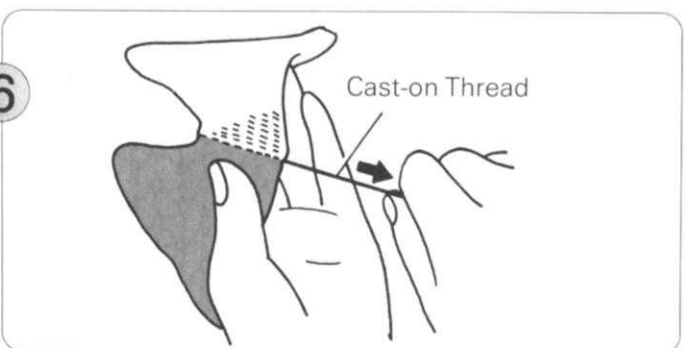

6 If you pull out the Cast-on Thread, the waste knitting will drop away.



# [ BACKSTITCH CASTING OFF (BINDING OFF) ] USING THE TAPESTRY NEEDLE (ENDING WITH K-CARRIAGE ON THE LEFT)

- With this method you will achieve a thin, elastic edge so it is suitable for any type of knitting.
- The yarn is on the lefthand side. Take yarn out of the Yarn Feeder and cut it leaving a length three times the width of the knitting.

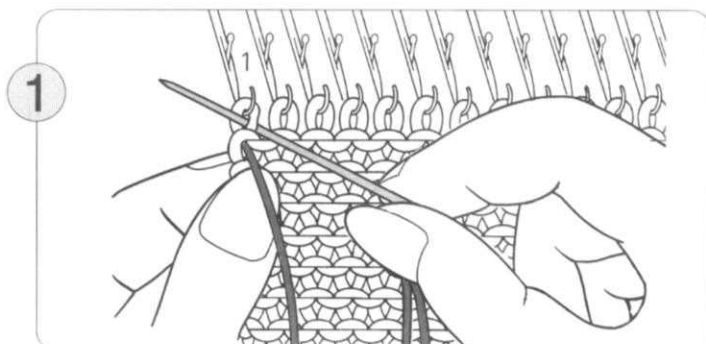
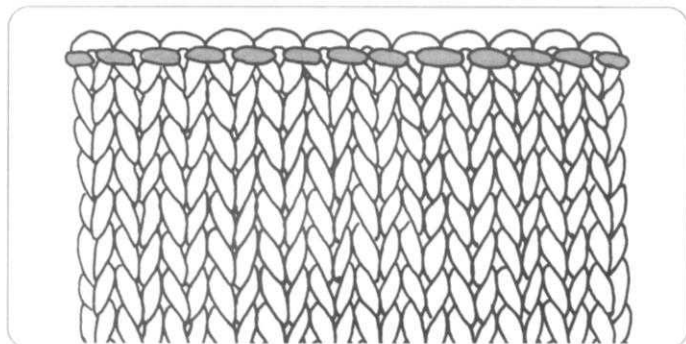

Thread yarn end into a Tapestry Needle. From the back, pass needle through the first stitch at the left (1).

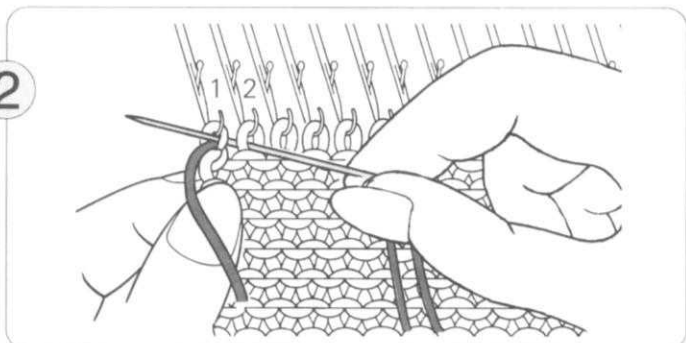

From the front, insert the needle in through the second stitch (2) and back out through the first stitch (1).

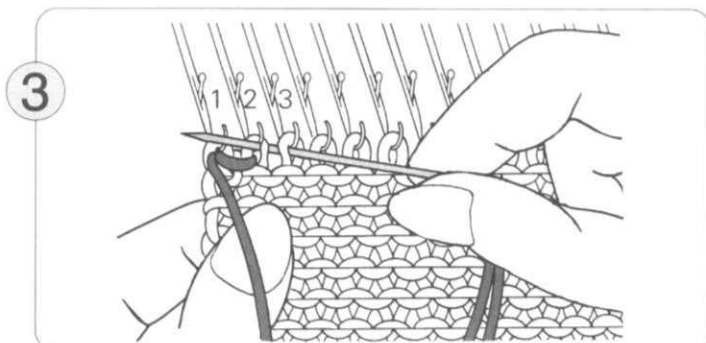

From the front, insert the needle in through the third stitch (3) and back out through the second stitch (2).

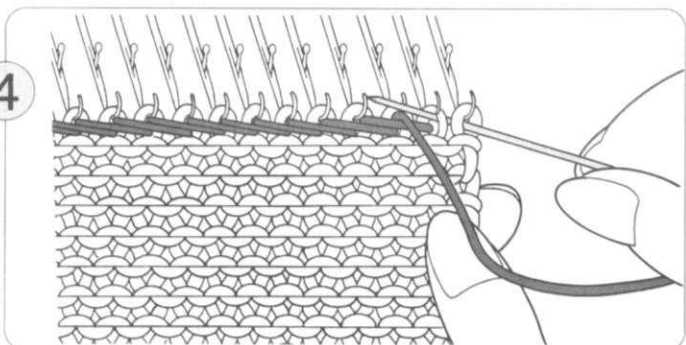

Continue in this way until you reach the righthand edge of the knitting.

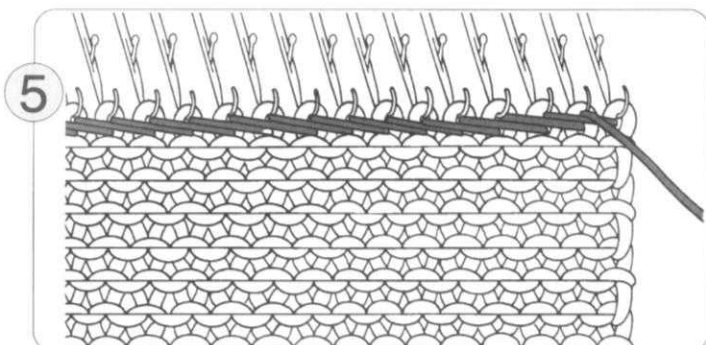

The casting off (binding off) is now completed and you can remove the knitting from the machine. If you find it easier, you can remove the stitches a few at a time whilst you work, so that you can place your lefthand behind the knitting.

## USING THE TAPESTRY NEEDLE (ENDING WITH K-CARRIAGE ON THE RIGHT)

- With this method you will achieve a thin, elastic edge so it is suitable for any type of knitting.
- The yarn is on the righthand side. Take yarn out of the Yarn Feeder and cut it leaving a length three times the width of the knitting.

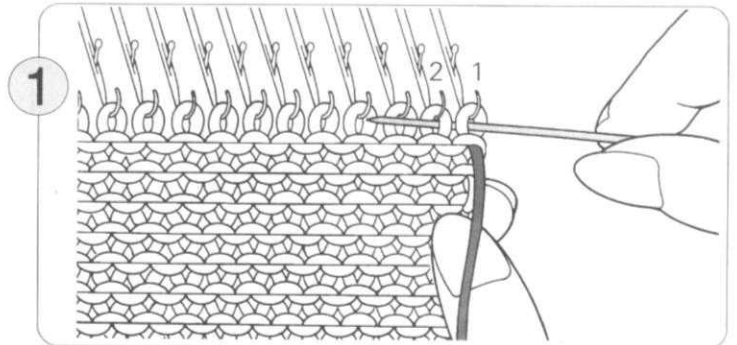
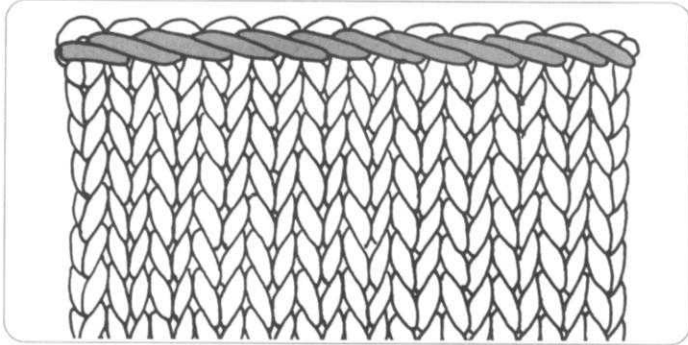

Thread yarn end into a Tapestry Needle. From the front, pass needle through the first stitch at the right (1), and back out through the second stitch (2).

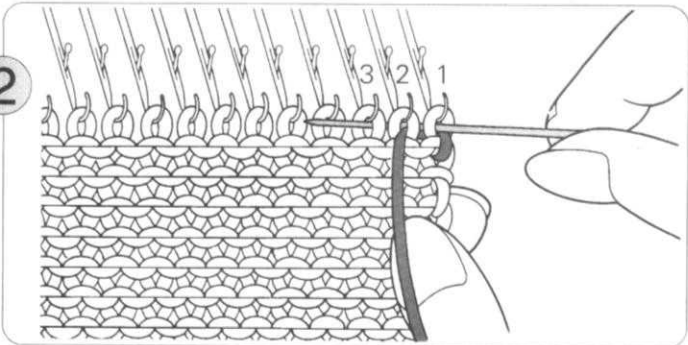

From the front, insert the needle in through the first stitch (1) and back out through the third stitch (3).

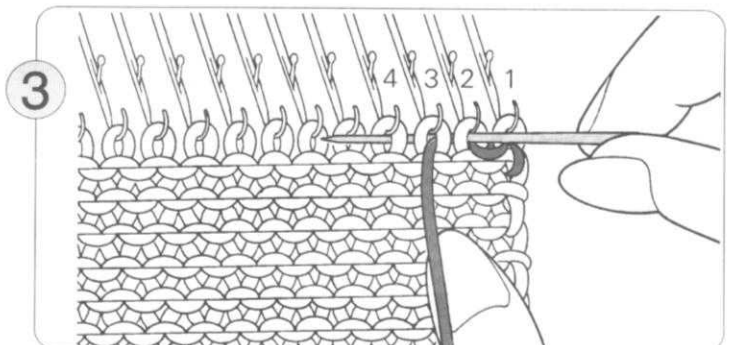

From the front, insert the needle in through the second stitch (2) and back out through the fourth stitch (4).

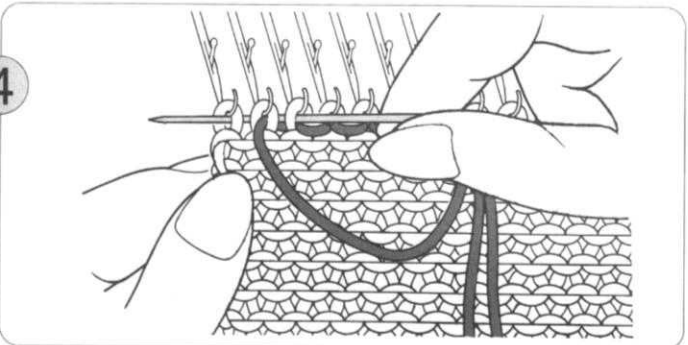

Continue in this way until you reach the lefthand edge of the knitting.

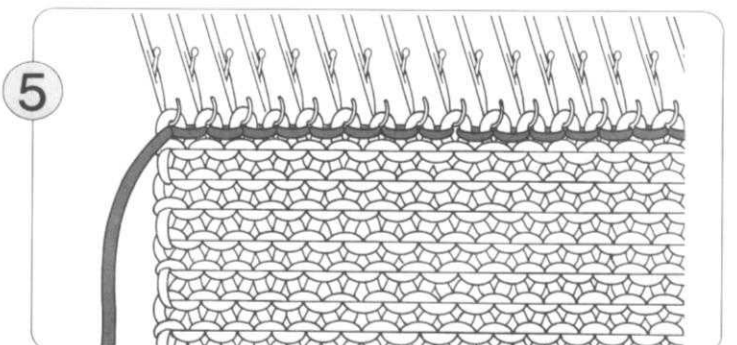

The casting off (binding off) is now completed and you can remove the knitting from the machine.

## 【CHAIN STITCH CAST OFF (BINDING OFF) USING THE LATCHET TOOL】

- With this method you will achieve a firm edge which is not very elastic.

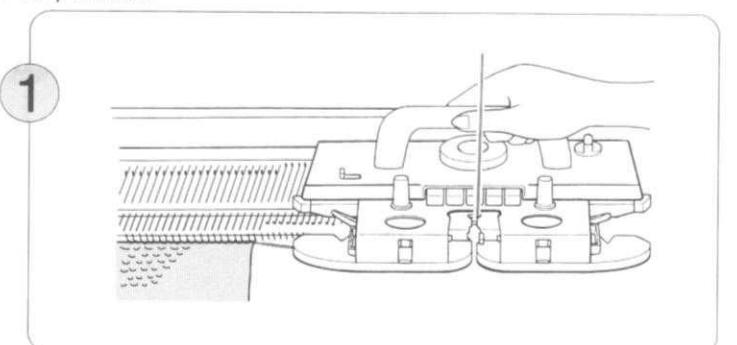
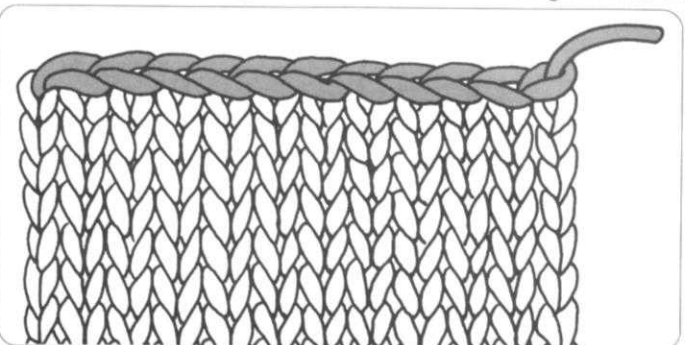

Knit the final row from right to left. Loosen the Tension Dial for this row (e.g. if main tension is say 4-6, knit the final row at tension 9-10).

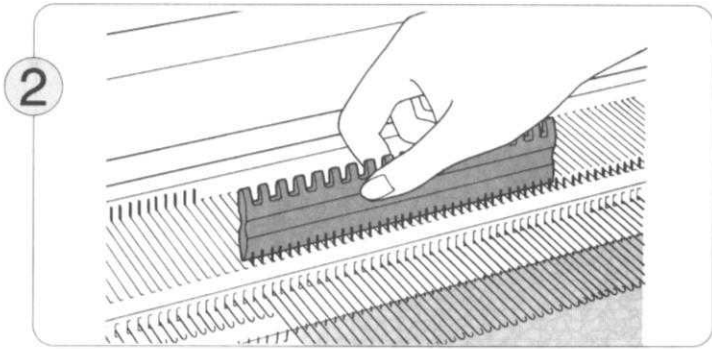

2 Bring the needles forward to E position.

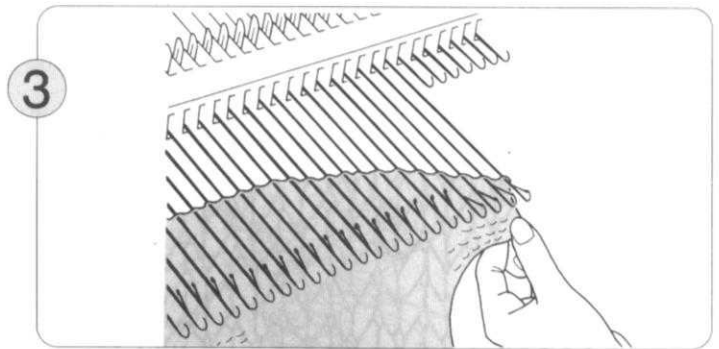

3 Gently bring the knitting towards you, taking care not to drop any stitches.

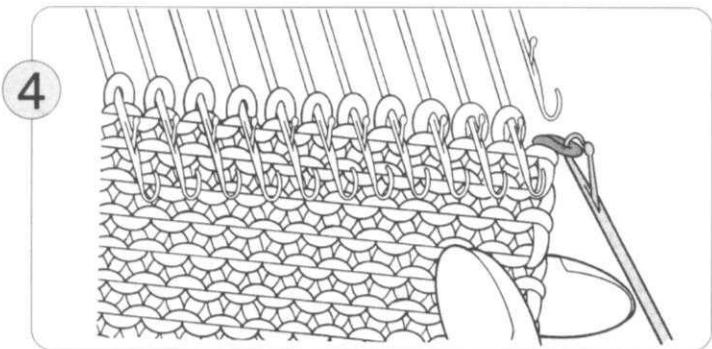

4 Beginning at the righthand edge, hook the first stitch onto the Latchet Tool.

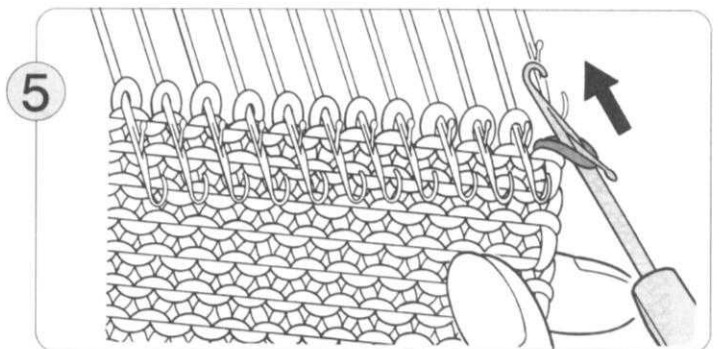

5 Put the stitch behind the latch of the Latchet Tool.

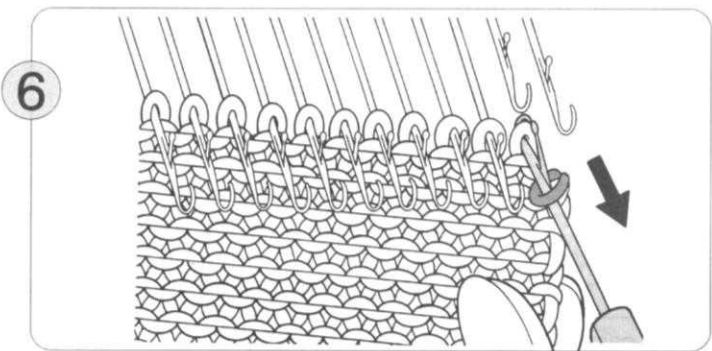

6 Now hook the second stitch with the Latchet Tool, keeping this stitch in the hook.

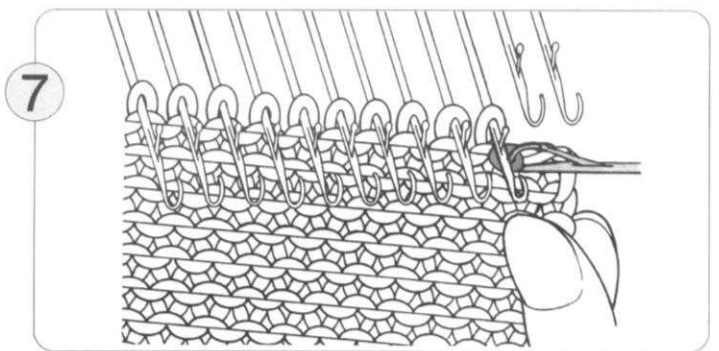

7 Draw the second stitch through the first stitch, letting the first stitch slip off over the hook.

♣ Take care not to drop any of the other stitches from off the needles whilst you work.

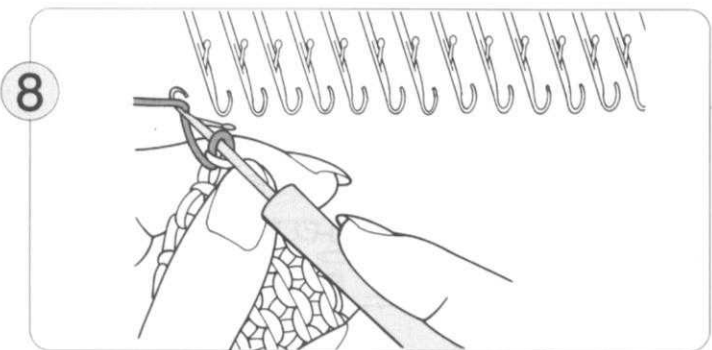

8 Repeat this until you reach the last stitch. Now hook the yarn end with the Latchet Tool as shown, and pull this through the last stitch.

## [ WASTE KNITTING (CAST OFF) ]

You can remove your knitting from the machine with rows of waste knitting. Use this when you want to return the stitches to the needles again e.g. to knit a cuff.

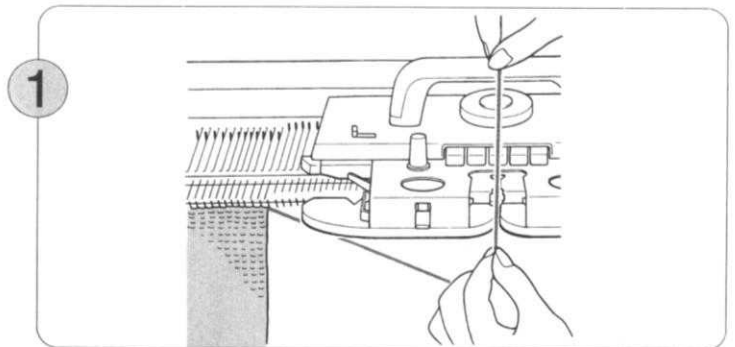
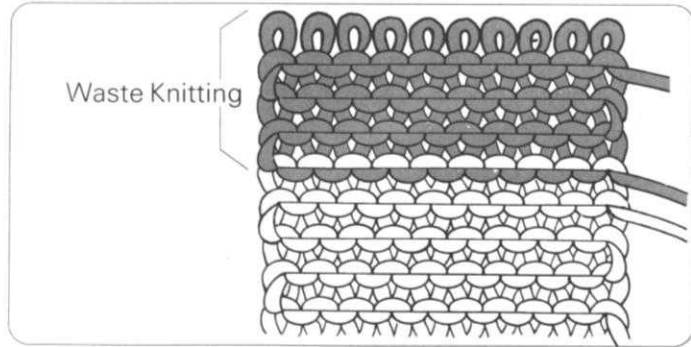

1 Take the yarn out of Yarn Feeder "A".

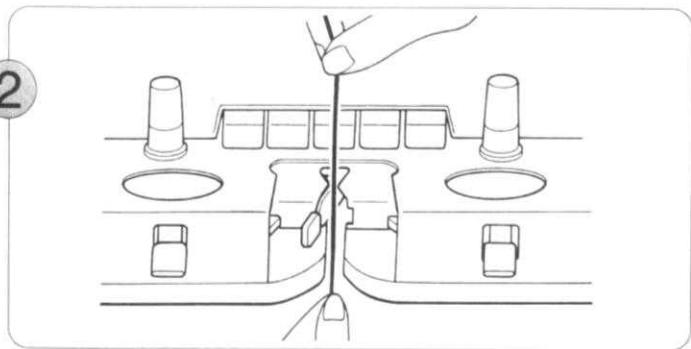

2 Thread the waste yarn into Yarn Feeder "A".

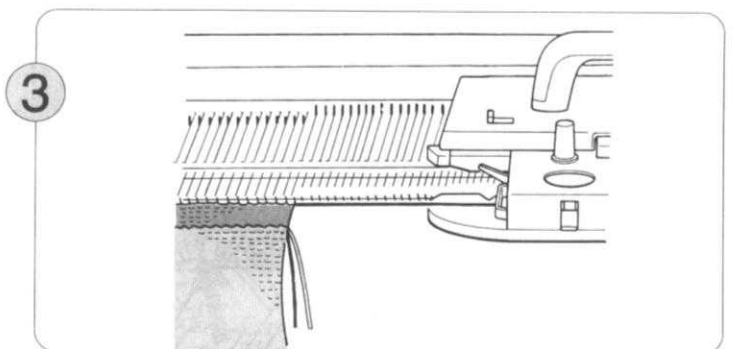

3 After knitting several rows with waste yarn, remove the knitting by passing the empty carriage across the stitches.

## [ CORD KNITTING ]

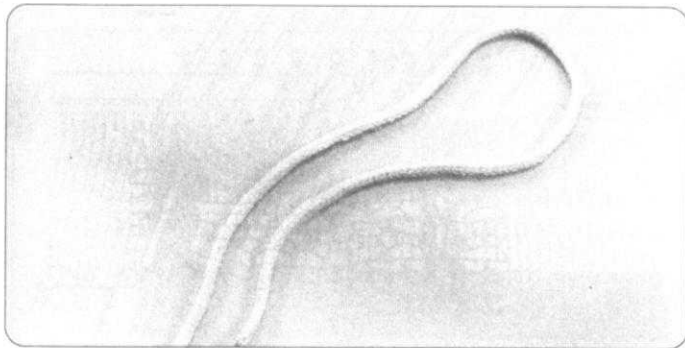

- Using the Skip Stitch facility, you can make seamless cords. Set the Tension Dial to approx. one number lower (tighter) than you did for the same yarn in stocking stitch.

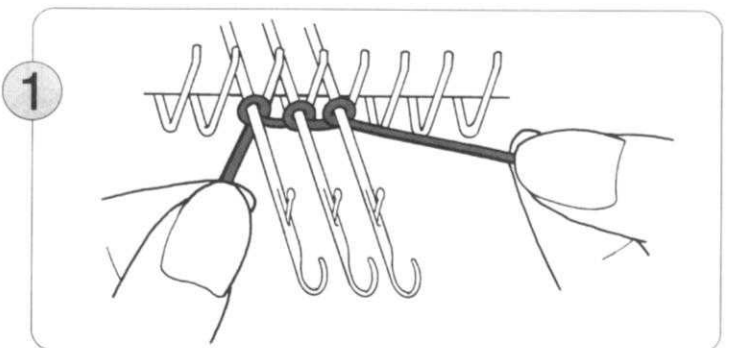

1 Using the "E" wrap method, cast on 3 or 4 stitches.

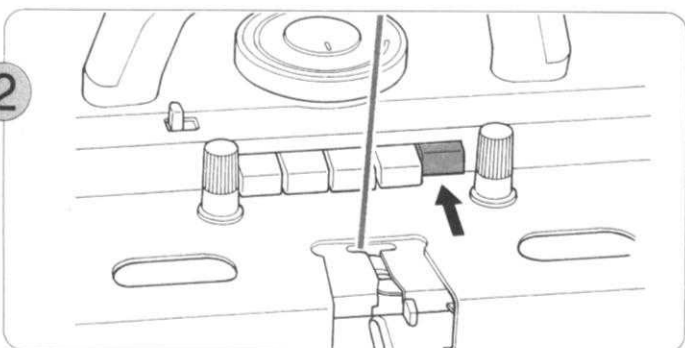

2 Place the K-Carriage on the right of the machine and push in the right Part Button.

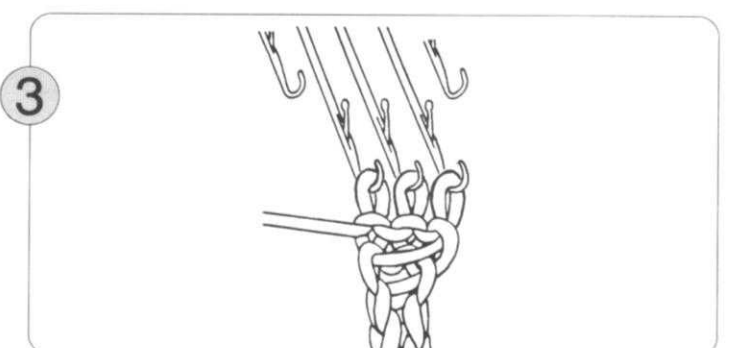

3 Operate the K-Carriage at the same time pull down the knitting with your other hand.



# [ CABLE STITCH PATTERN ]

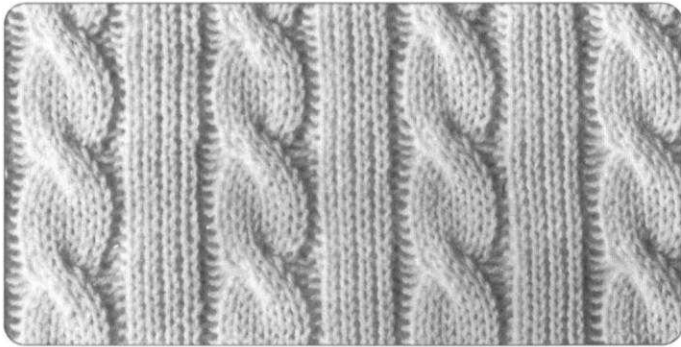

- Cables are made by crossing two sets of stitches using two Transfer Tools. The following example uses two 3-eyed Transfer Tools.

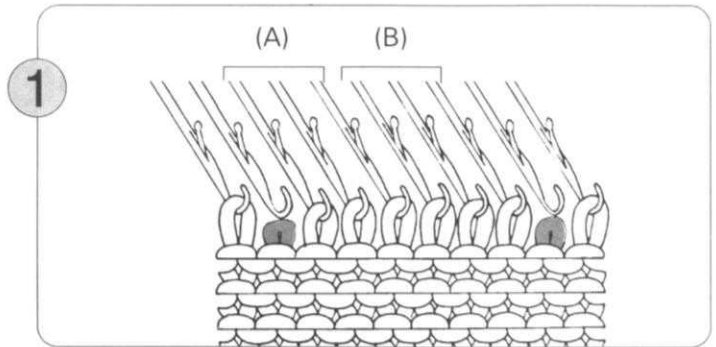

Knit until you reach the point for your first cable crossover. Drop one stitch on either side of the cable pattern stitches.

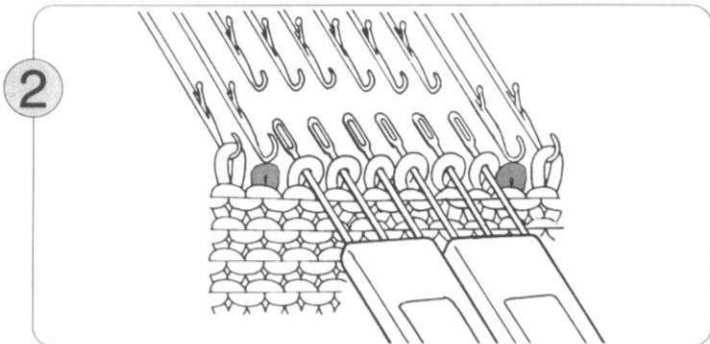

Transfer 3 stitches onto both 3-eyed Transfer Tools as shown.

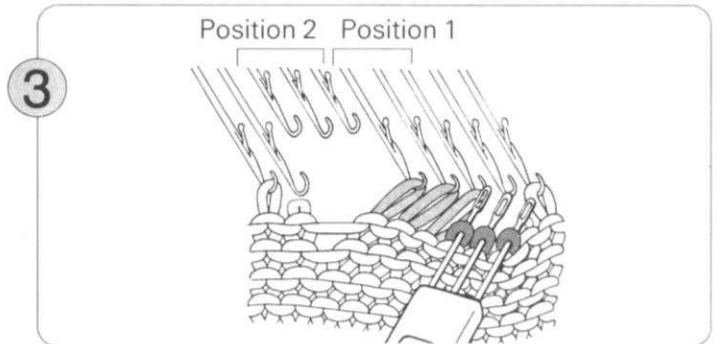

Transfer the stitches marked (A) to Position 1.

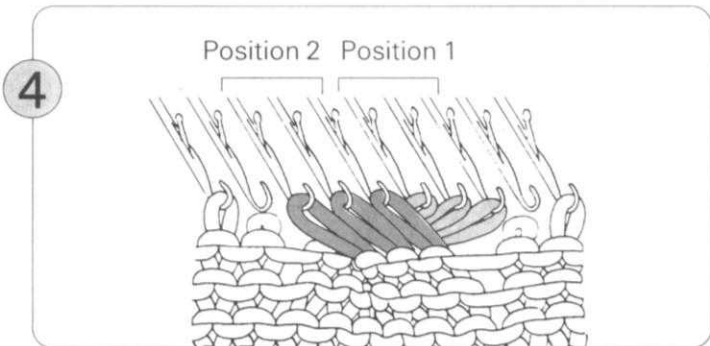

Transfer the stitches marked (B) to Position 2.

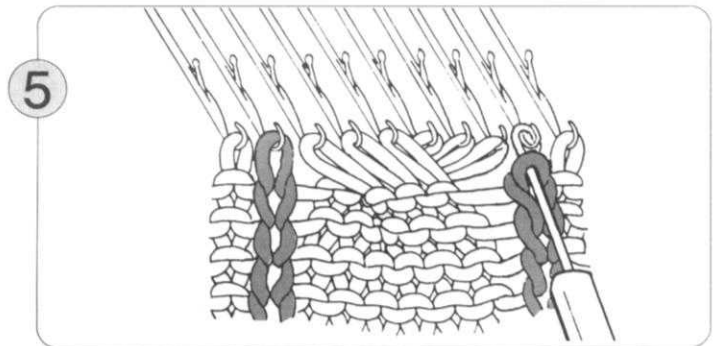

Allow the stitches on either side of the cable which you dropped in Step ①, to ladder down, and using the Latchet Tool reform them into purl stitches.

# [ HOW TO MAKE A HEM ]

## PLAIN HEM

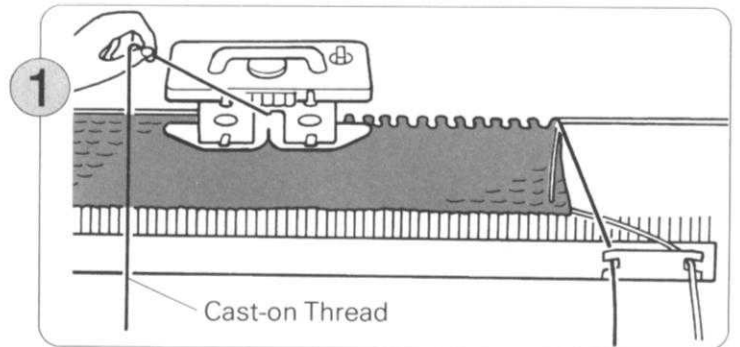
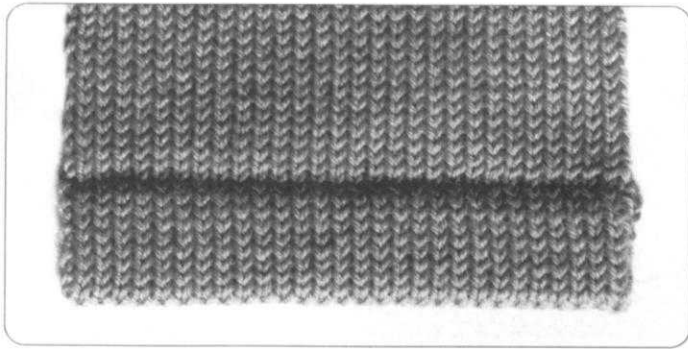

Knit several rows with waste yarn and then knit one row with the Cast-on Thread. (Refer to P.88).

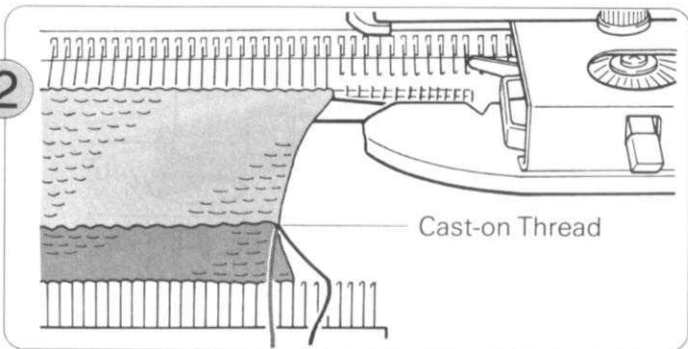

Working in stocking stitch, knit the number of rows required for double the depth of the hem (e.g. if hem is to be folded under 2.5 cms (1") then knit 5 cms (2").

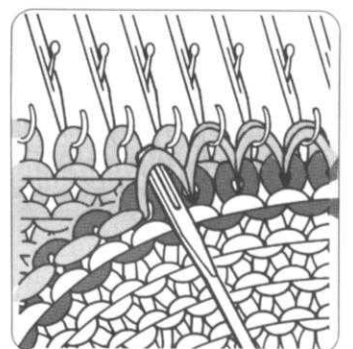
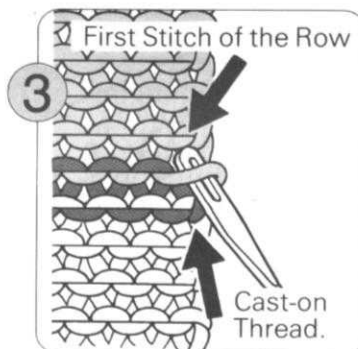

Using your Transfer Tool, pick up the first stitch of the row above the Cast-on Thread. Continue picking up stitches across the row. (Note: there will be one less stitch to be picked up than there are needles).

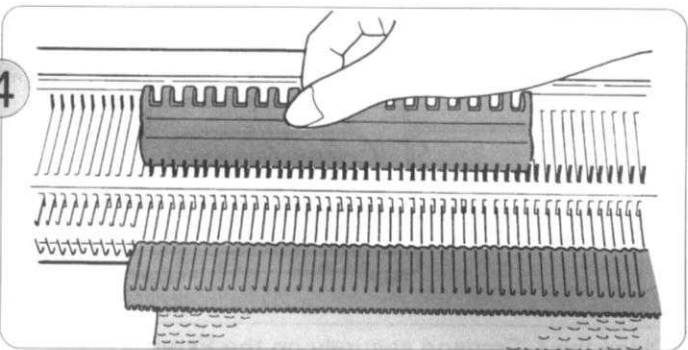

After you have picked up all the stitches, bring the needles forward to E position.

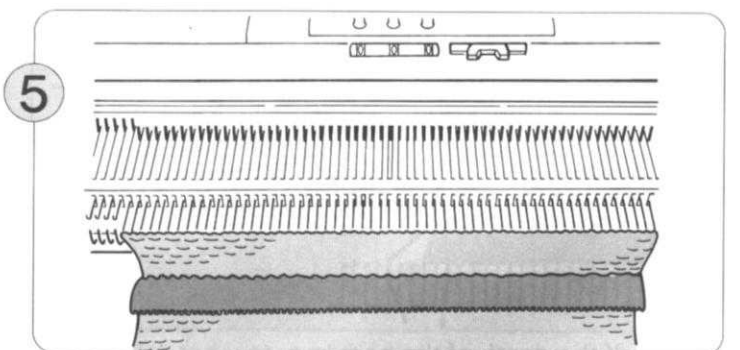

Knit one row with the K-Carriage. Continue knitting in stocking stitch.

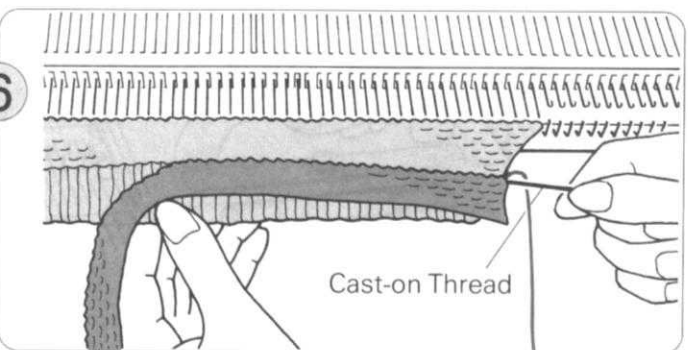

When you have knitted several rows you can pull out the Cast-on Thread. The waste knitting will fall away.

## PICOT HEM

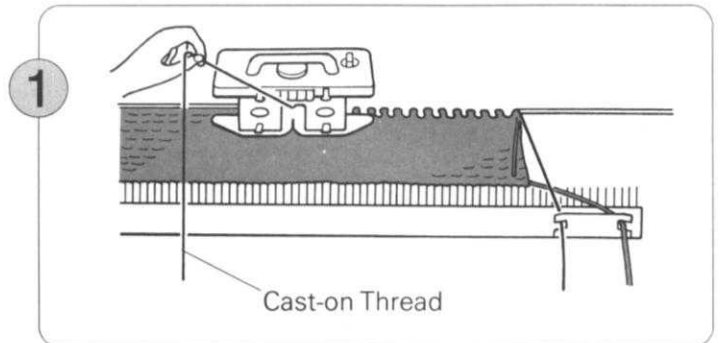
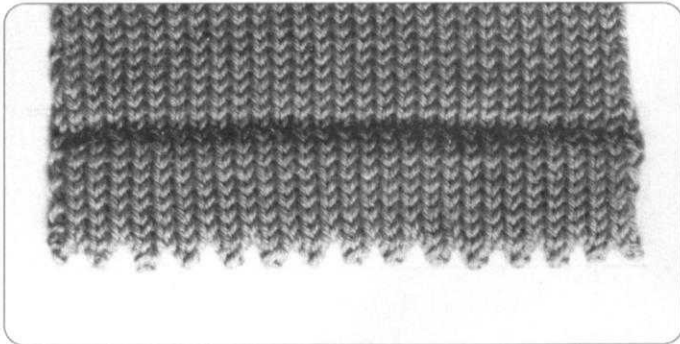

Knit several rows with waste yarn and then knit one row with the Cast-on Thread. (Refer to P.88).

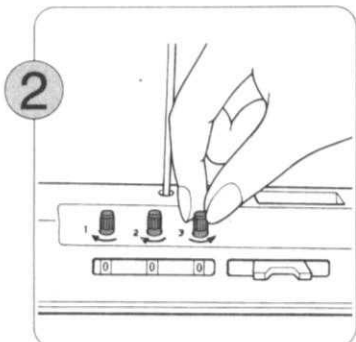

Set the Row Counter to 000 and the Row counter Tripper to working position.

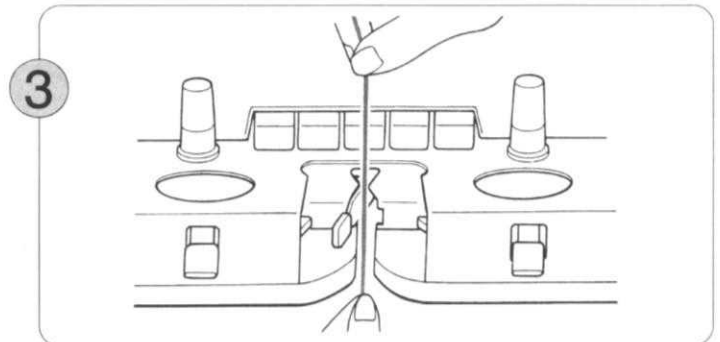

Thread the yarn into Yarn Feeder "A".

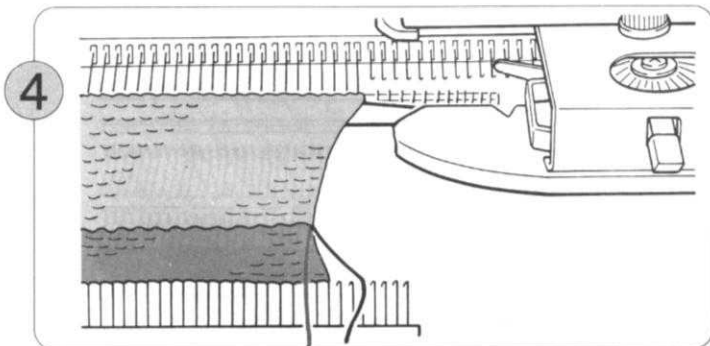

Knit half the depth of the hem (e.g. to what will be the foldline). Place the K-Carriage on the Extension Rail at the right. Note the number showing on the Row Counter.

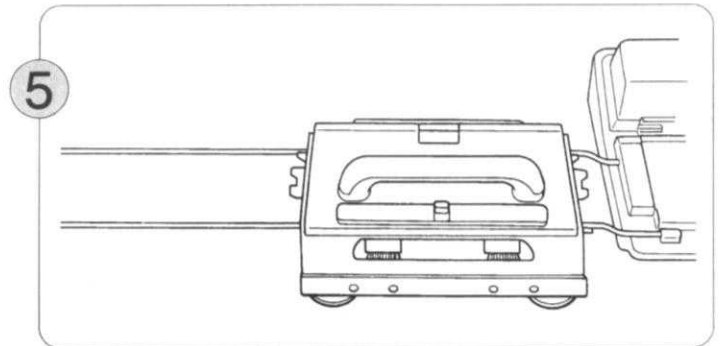

Place the L-Carriage securely on the Extension Rail at the left.

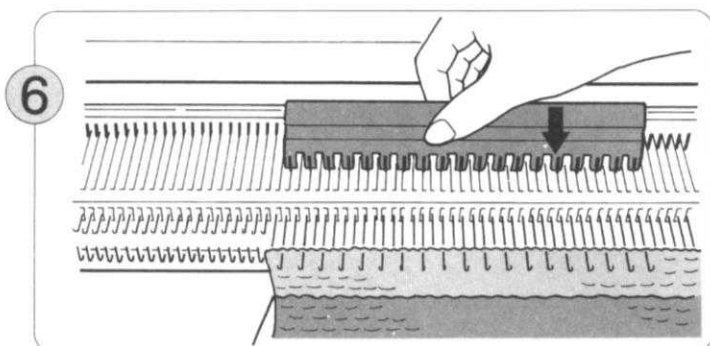

Starting with the second needle from either end, bring every alternate needle forward to D position using the 1/1 Needle Pusher. The end needles must remain in B position.

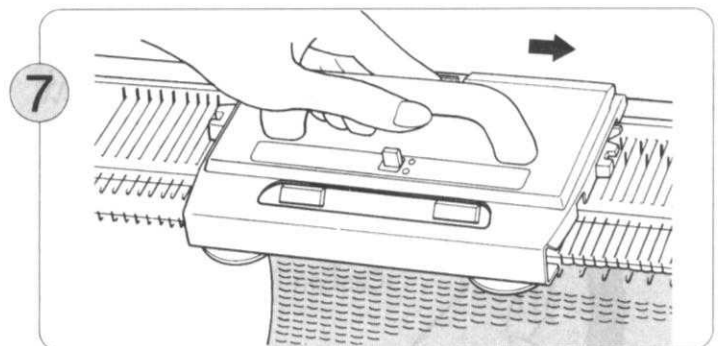

Set the Lace Change Lever to N and move the L-Carriage to the right.

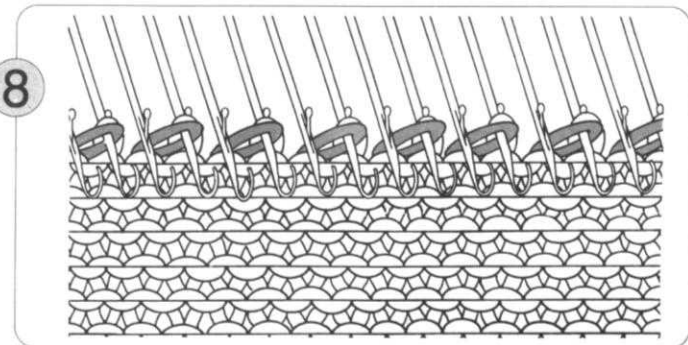

8 Every second stitch has now been transferred to the adjacent needle.

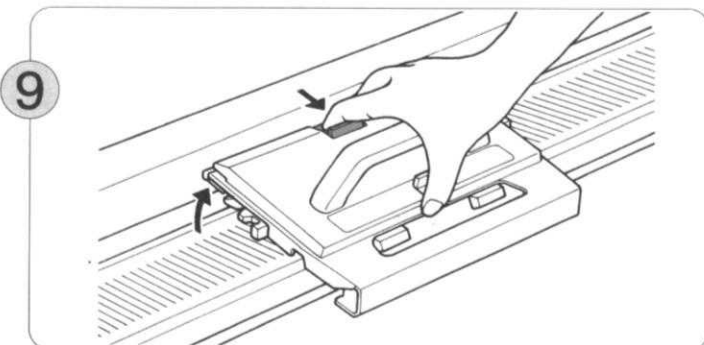

9 Remove the L-Carriage from the machine by depressing the Release Button.

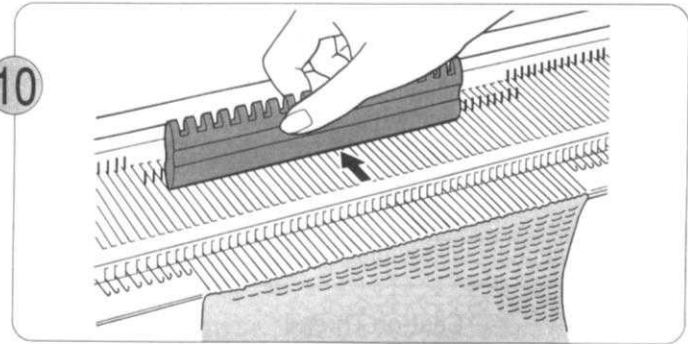

10 Return the needles to B position using the flat side of the 1/1 Needle Pusher.

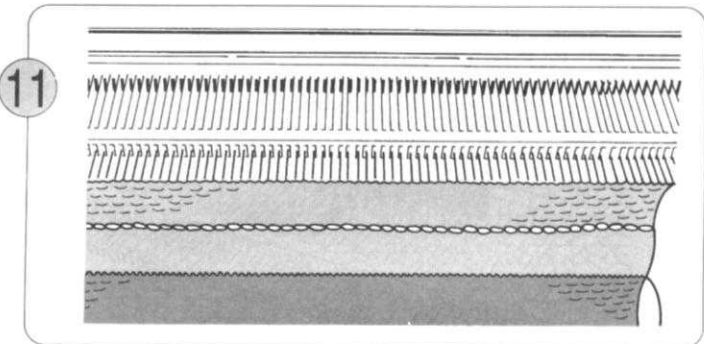

11 Set the Row Counter to 000 and knit the second half of the hem (i.e. the same number of rows as for the first half).

12 Repeat Steps ③ – ⑥ on P.94 to finish the hem.



## 1 × 1 ELASTIC HEM

(This type of hem is also referred to as "Mock Ribbing" or "Continental Ribbing".)

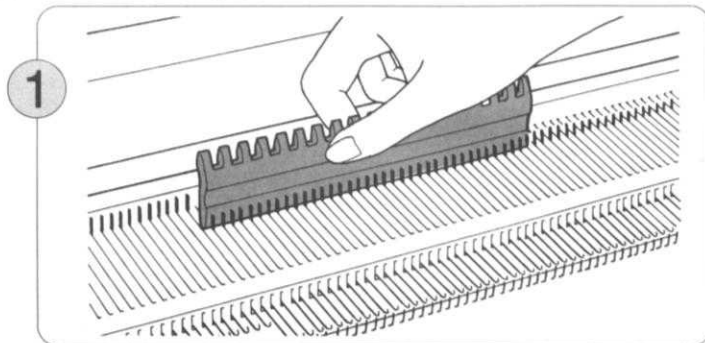
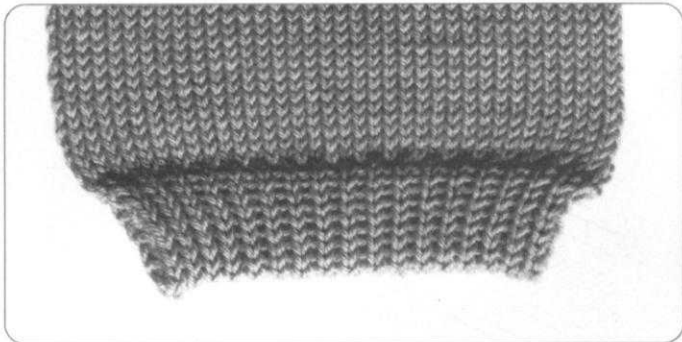

Using the flat side of the 1/1 Needle Pusher, bring forward the required number of needles to B position.

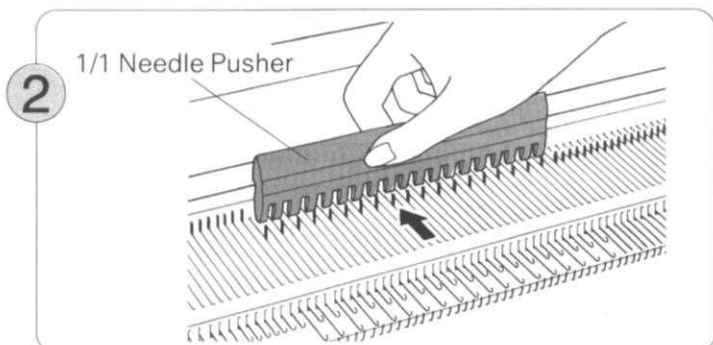

With the 1/1 Needle Pusher take every other needle back to A position.

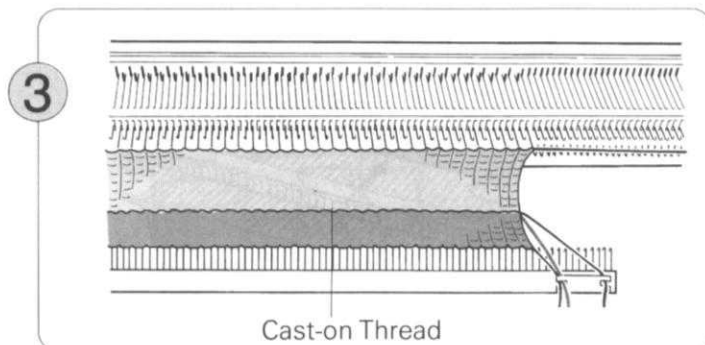

Knit several rows with waste yarn, then one row with the Cast-on Thread. With main yarn, working in stocking stitch, knit the number of rows required for double the length of the hem.

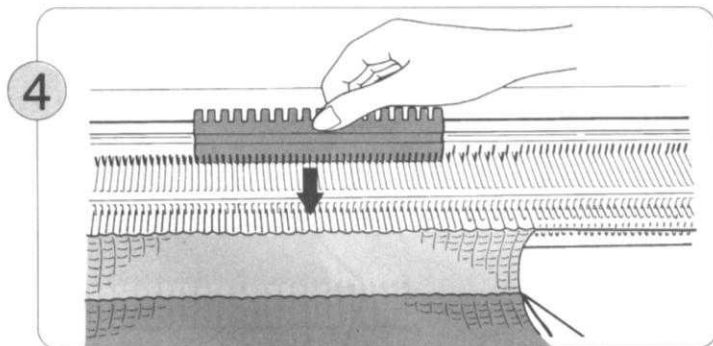

With the flat side of the 1/1 Needle Pusher, bring the needles in A position forward to B position.

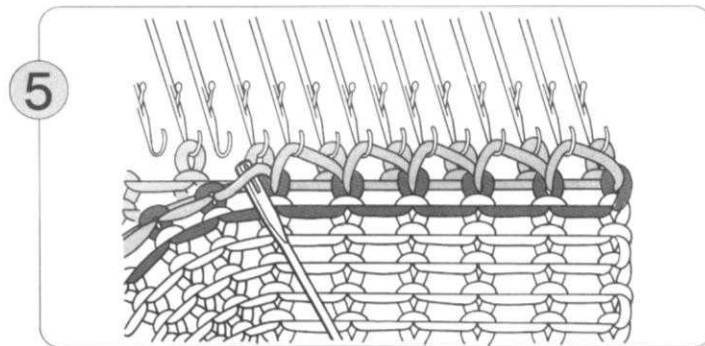

Pick up the stitches in the same way as for the plain hem, and hook them onto the empty needles.

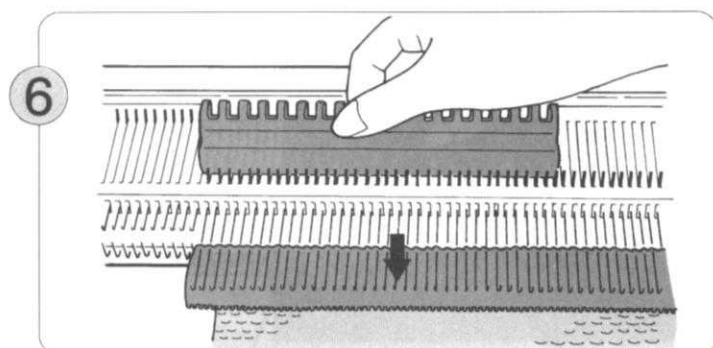

When all the stitches have been picked up, bring the needles forward to E position. Knit one row.

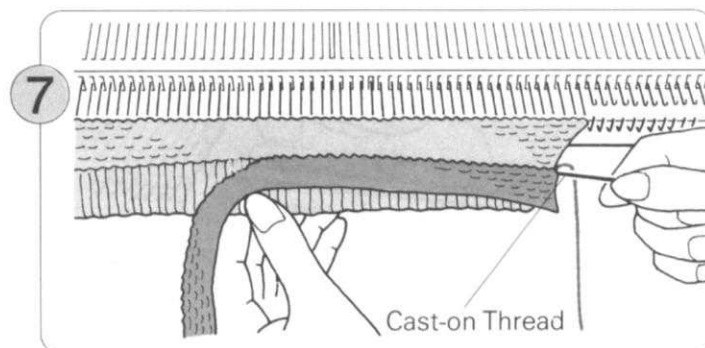

After you have knitted several rows, pull out the Cast-on Thread. The waste yarn drops away.

# [ HOW TO MAKE A BUTTONHOLE ]

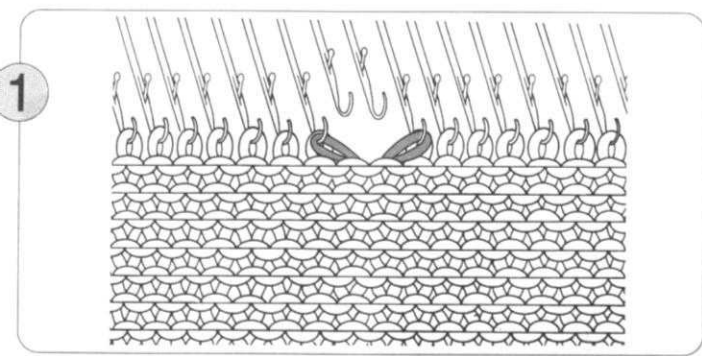

Using the 1/2 Transfer Tool, move the two stitches on-to adjacent needles as illustrated.

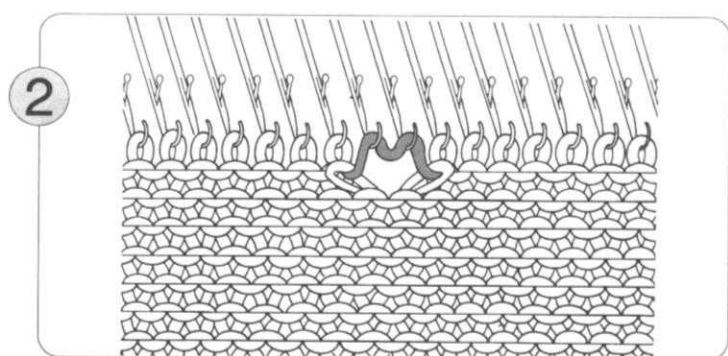

Place empty needles in B position and knit one row. The yarn has hooked over these two needles.

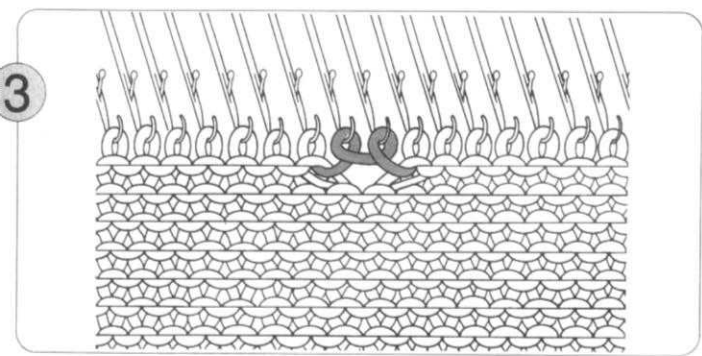

Loop the yarn around the two needles by hand as shown above.

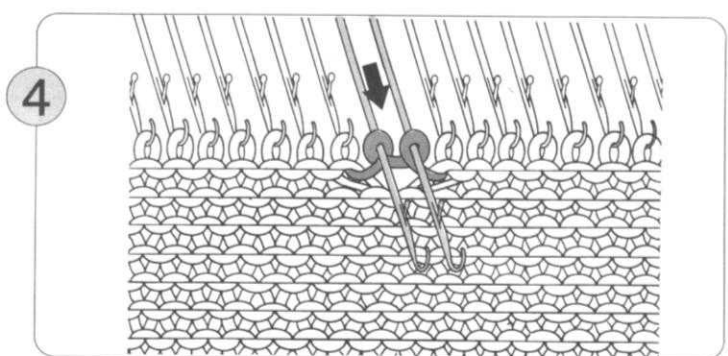

Bring the two needles forward to E position and knit one row.

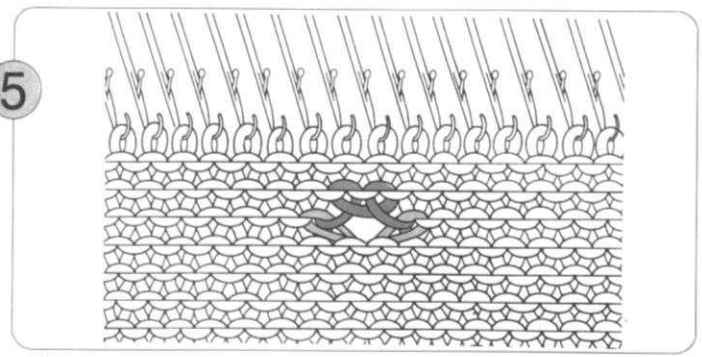

You have now made a buttonhole.

## [ USING A SEWING MACHINE FOR MAKE-UP ]

You can use your sewing machine to join your garments together. Either straight stitch or a zigzag stitch machine is suitable, but it is best to use sewing thread which stretches and is specially made for sewing knitwear. Choose a colour to match your yarn.

### BEFORE YOU BEGIN TO SEW

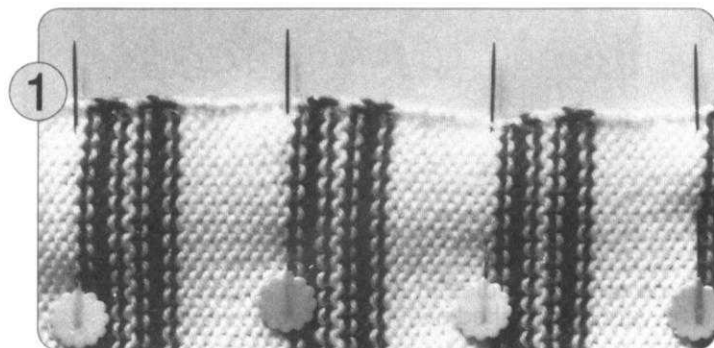

1

Pin together the parts to be basted.

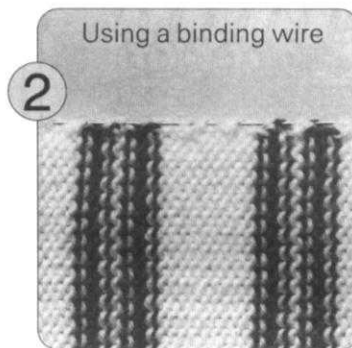

2

Using a binding wire

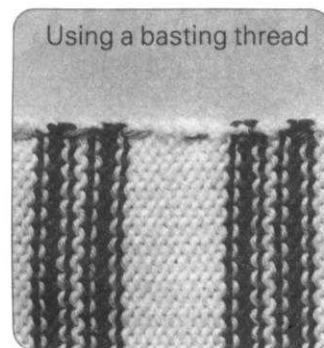

Using a basting thread

Baste the seams using either a basting thread or the binding wire included with your Knit Leader.



3

Slowly sew seam with your sewing machine easing the seam slightly whilst you sew, and taking care not to stretch the fabric too much. Allow a seam of approx. 3-5 mm.

### ORDER OF MAKE-UP

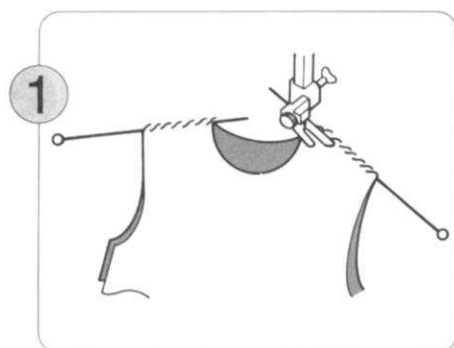

1

Shoulders (right and left).

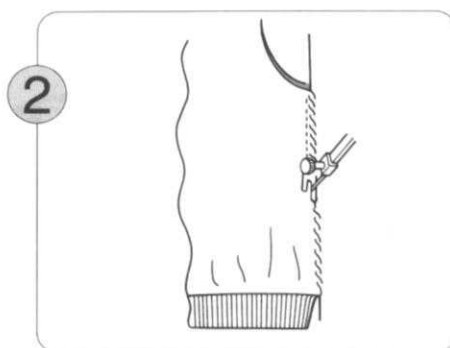

2

Side seams.  
Sew ribbing together by hand.

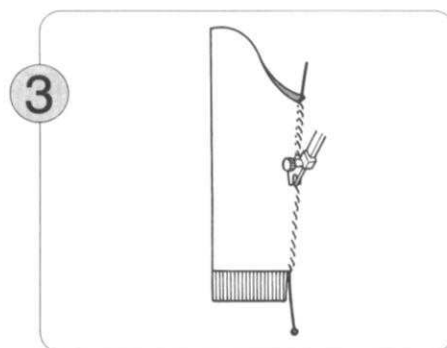

3

Sleeve seams.  
Sew ribbing together by hand.

4

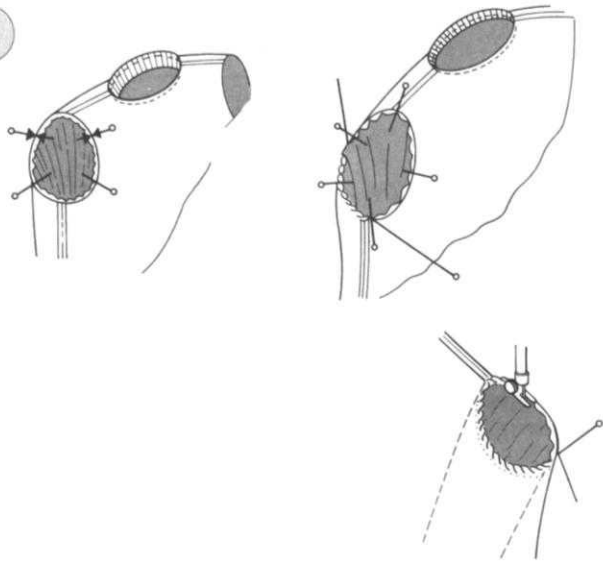

- 1) With garment body and sleeves inside out, pin sleeves around armhole edges.
- 2) Baste the armhole seam, using either basting thread or the binding wire.
- 3) Sew with a sewing machine.

How to set in the sleeves.

5

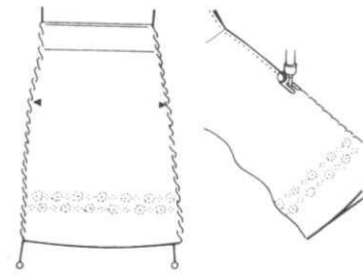

How to sew a skirt.

## 【SEAMING】

- Using a tapestry needle, pick up half of the edge stitch as shown below.

1

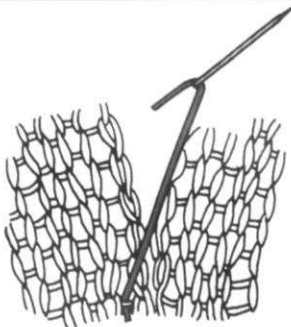

2

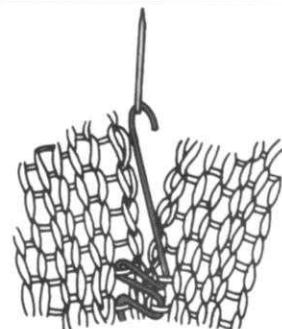

3





4



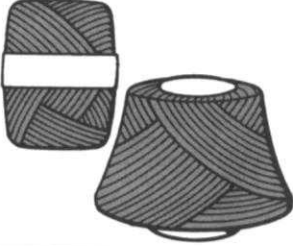
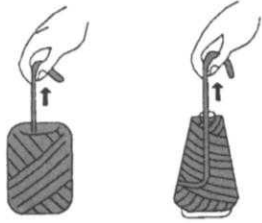

## [ PREPARING YOUR YARN ]

- When you are new to machine knitting, you are advised to start with new yarn. Choose one that is smooth and of reasonably good quality. Avoid hairy and harsh, poor-quality yarns as they are difficult to knit.

	<p>These yarns are suitable for use without rewinding.</p> <ul style="list-style-type: none"> <li>♣ Pull the yarn from the center of a ball yarn. Use the yarn from the outside of a coned yarn.</li> </ul>	
	<p>These yarns should be rewound using a Skein Holder and a Yarn Winder.</p>	

Both the Skein Holder and Yarn Winder can be purchased separately.

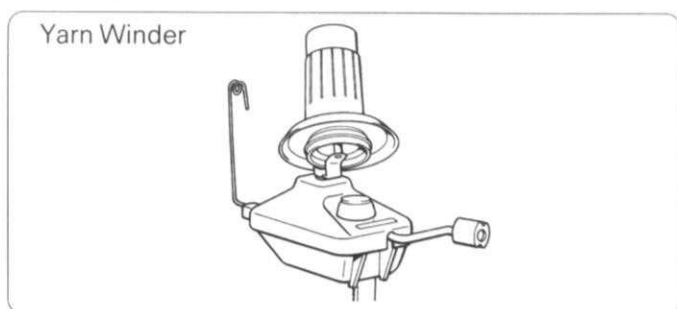
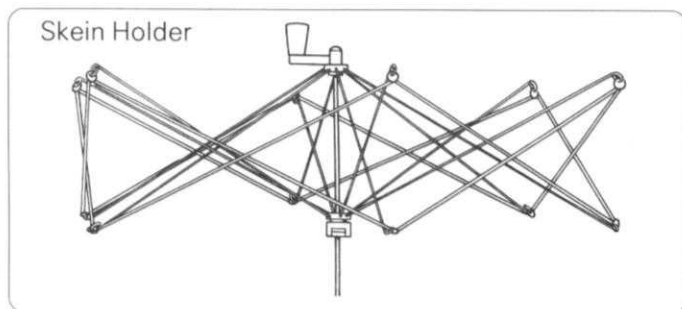

### • Rewinding the yarn

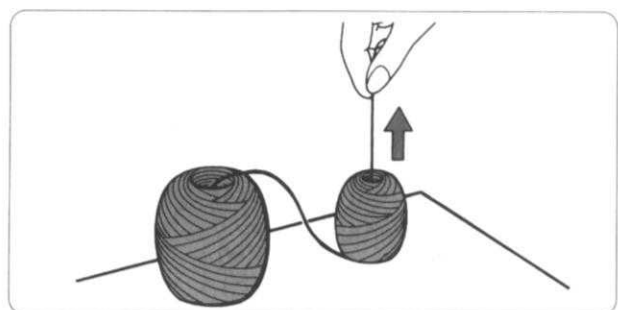
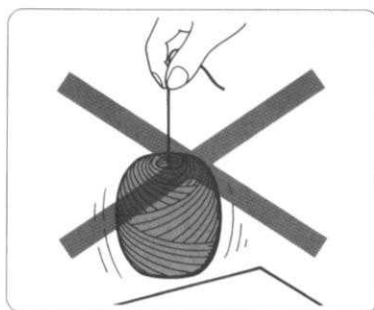
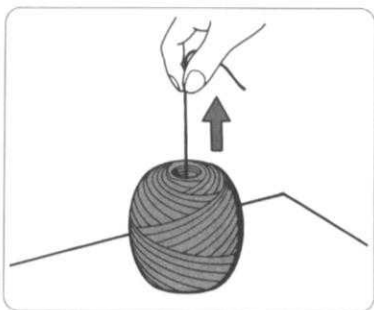
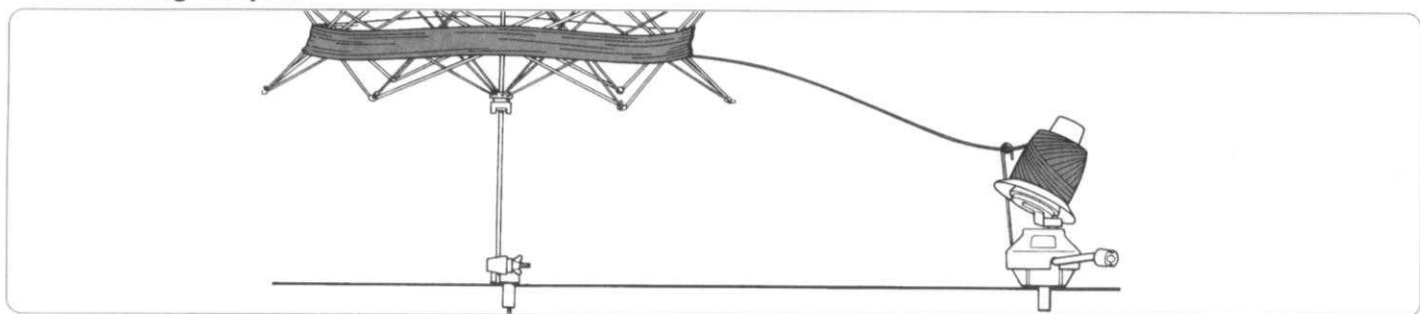

Yarn pulled from the centre of a rewind ball should come out freely without lifting the ball from the table.

If the yarn does not flow freely, pull some yarn out of the centre of the ball.

# REPLACING A NEEDLE

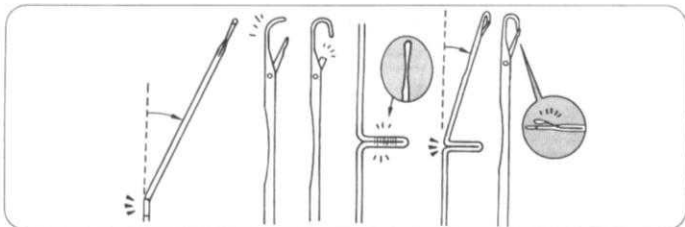

- Needles that are bent, broken or damaged will cause problems during knitting. If you experience dropped or badly knitted stitches you should check the needles and replace any faulty ones immediately. In an emergency if you have no spare needles, use one from the extreme edge of the needle bed.

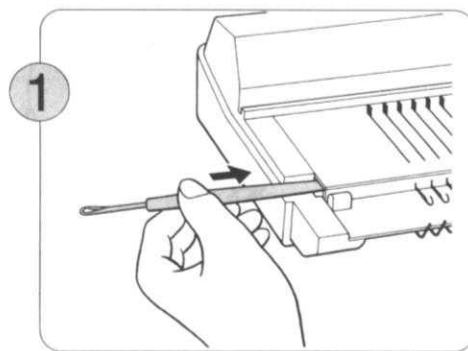

1 Push one end of the sponge Presser Bar with the handle of your Latchet Tool until it appears at the other end.

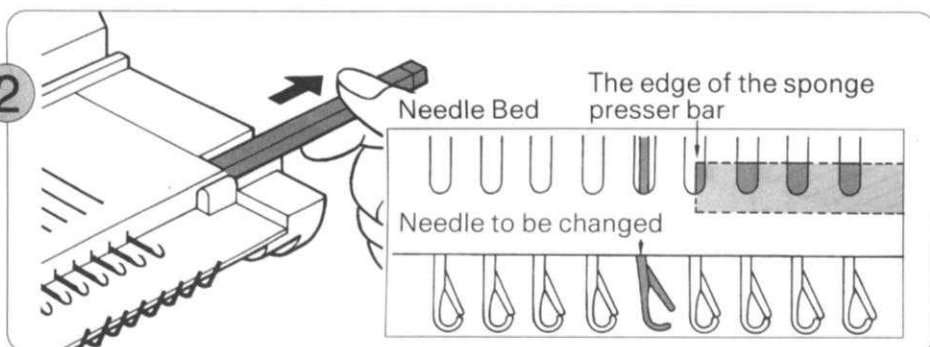

2 Draw the Bar out by hand until it passes the needle to be replaced.

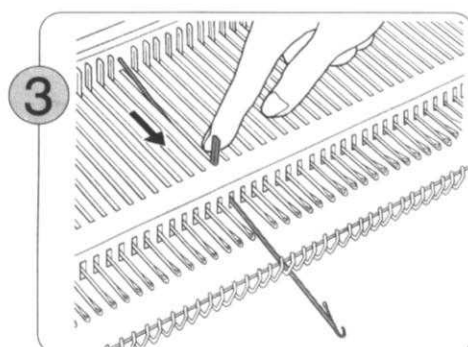

3 Push the faulty needle forward to E position as far as it will go.

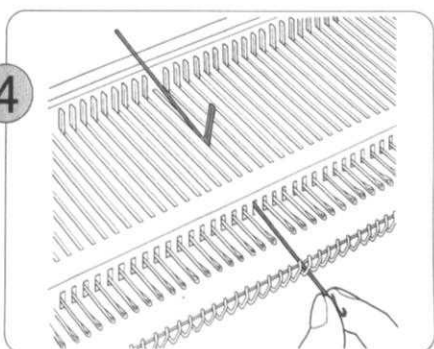

4 Press down at the hook end so that the shank end of the needle is raised clear of the needle bed.

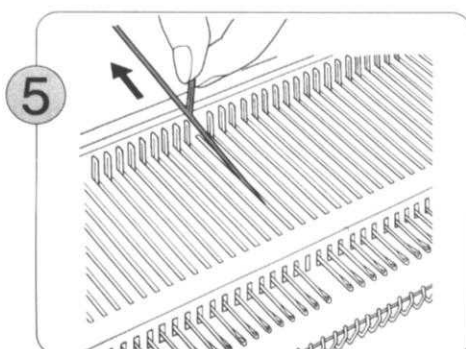

5 Catch hold of the shank end and lift the faulty needle out from the needle bed.

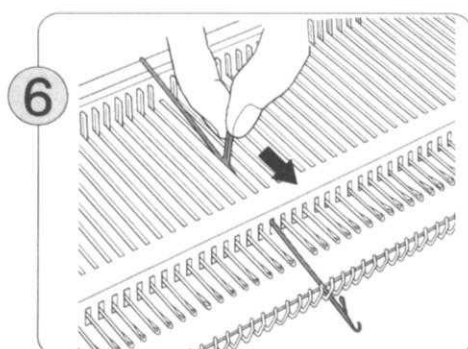

6 With the latch open, insert the new needle as shown.

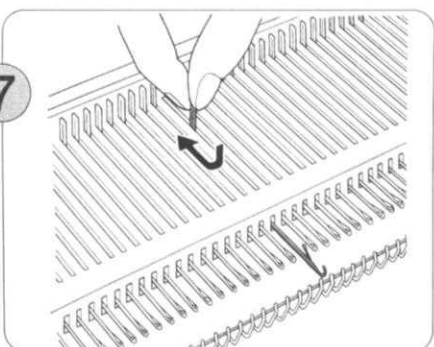

7 Return needle to A position.

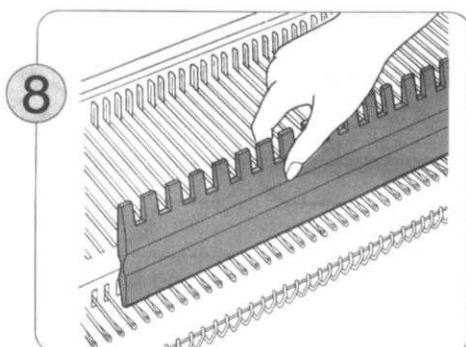

8 Holding the needles down with your hand or the flat side of your 1/1 Needle Pusher, push the sponge Presser Bar back in place.

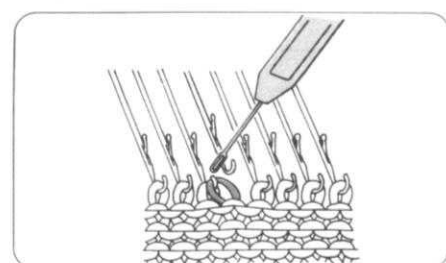

♣ If you need to replace a needle whilst you have knitting on the machine transfer the stitch from the faulty needle onto an adjacent needle. Replace the stitch after you have completed the replacement.

# CLEANING AND MAINTENANCE

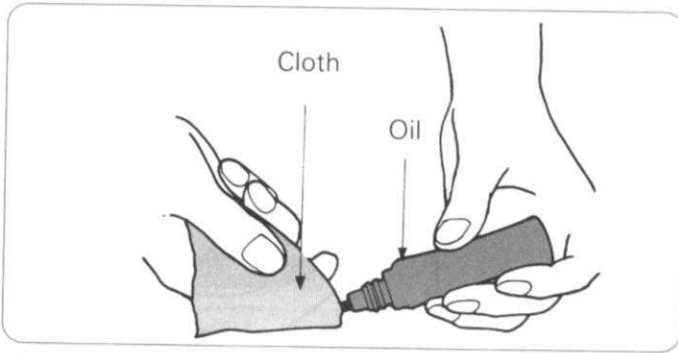

Wipe the metal parts with an oily cloth and clean plastic parts with a soft cloth and mild, neutral detergent.

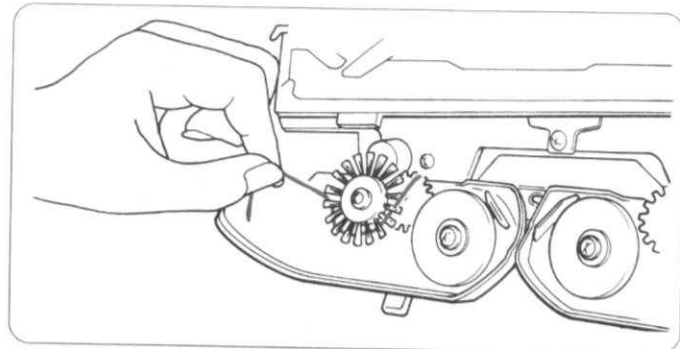

Remove the K and L Carriages from the needle bed and brush away any dust or fluff. Check that the brushes are free from fluff or strands of yarn, and that they revolve smoothly.

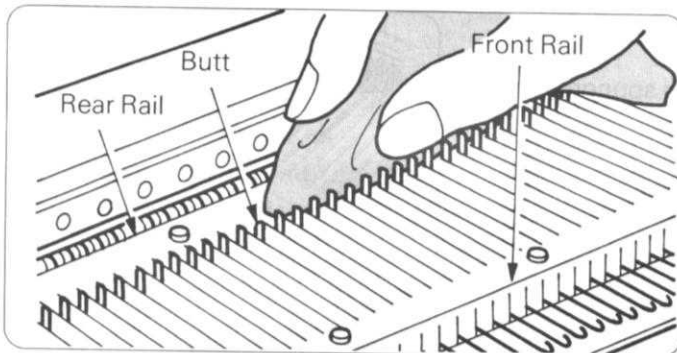

Arrange all needles in B position and clean the butts, rear and front rails as shown, using an oily cloth.

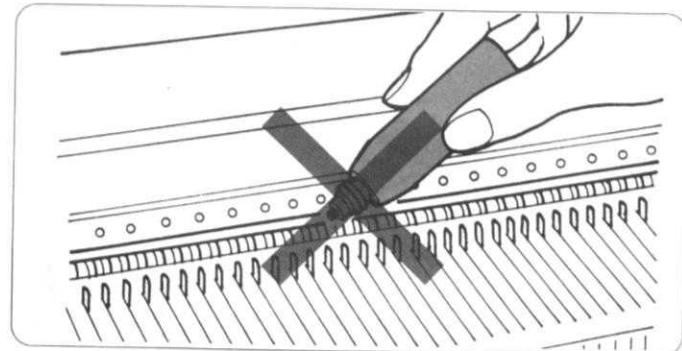

Do not put oil directly onto the machine.

Do not use alcohol, benzin, thinners or petrol.

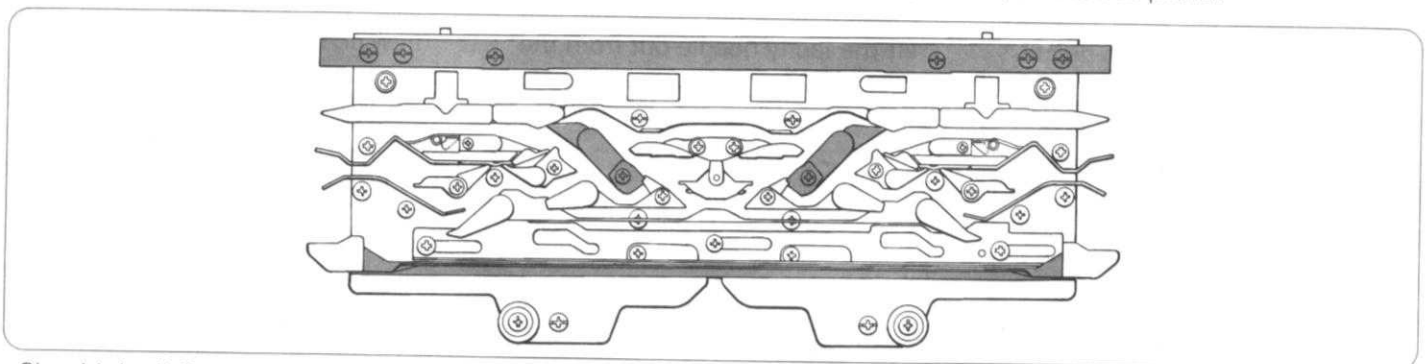

Should the K-Carriage feel heavy to operate, you should clean and lubricate the areas indicated above, using an oily cloth.

If you regularly clean and lightly oil your machine it will make knitting easier and help to prevent excessive wear.

♣ When you come to use your machine again after you have stored it for a while, knit 20 – 30 rows with waste yarn to clean away any dirty oil.

# LIST OF PATTERN VARIATION

Each punch card can be used for the pattern(s) marked ● in the following column.  
 Punch cards No. 17–20 (inc) are special cards for Lace Pattern and Fine Lace Pattern.

PATTERN	RECOMMENDED PUNCH CARD NO.																			
	1	2	3	4	5	6	7	8	9	10	11	12	13	14	15	16	17	18	19	20
Tuck Stitch Pattern	●	●	●				●	●												
Multi-colour Tuck Stitch Pattern	●	●	●				●	●												
Skip Stitch Pattern	●	●	●		●		●	●			●									
Multi-colour Skip Stitch Pattern	●	●	●		●		●	●			●									
Fairisle Pattern	●	●	●	●	●	●	●	●	●	●	●	●	●	●	●	●				
Weaving Pattern	●	●	●		●		●	●			●									
Plating Tuck Stitch Pattern	●		●					●												
Lace Pattern																	●	●	●	●
Fine Lace Pattern																	●		●	●



