

INSTRUCTION MANUAL
FOR TOYOTA PUNCH CARD KNITTER

MODEL K747



TABLE OF CONTENTS

1.	Parts Names	1
	* Main Body and Accessories	
2.	How to Use Accessories	3
3.	How to Assemble the Machine	6
4.	How to Operate Carriage	9
5.	How to Operate Needle Selection Device	10
	* Automatic Needle Selection Using The Punch Card	
6.	Preparation Before Knitting	14
	* Threading Machine	
	* Adjusting the Take-Up	
	* Cast-On	
7.	Guide for Knitting	18
	* Turned-Up Hem Knitting	
	* Increasing Stitch	
	* Decreasing Stitch	
	* Picking Up Dropped Stitches and Detaching the Carriage while Knitting	
	* Unraveling Knitting on the Machine	
	* Seaming	
	* Dividing for Neck	
	* Raglan Shaping	
	* Partial Knitting for Making Darts or Shoulder Line	
	* Partial Knitting in Plain Stitch	
	* Partial Knitting of Tuck Stitch	
	* Partial Knitting of Continuous Tuck Stitch	
	* Partial Knitting of Tuck Pattern Stitch, Slip Loop Tuck Stitch and Thread Knitting	
	* Partial Knitting of Fair Isle Knitting	
	* Manual Needle Selection	
	* Gauging and Drafting	
8.	How to Knit The Pattern Knitting	37
	* Fair Isle Knitting (Two Colour Knitting)	
	* Tuck Stitch	
	* Continuous Tuck Stitch	
	* Tuck Pattern Stitch	
	* Raised Tuck Pattern Stitch	
	* Whole Tuck Stitch	
	* Slip Loop Tuck Stitch	
	* Tuck Stitch Colour Combination Knitting	
	* Continuous Tuck Colour Combination Pattern Stitch	
	* Tuck Colour Combination Stitch	
	* Slip Loop Tuck Colour Combination Stitch	
	* Open Pattern Knitting	
	* Thread Knitting (Weaving)	
	* Manual Lace Pattern Knitting	
	* Rib Stitch Knitting	
	* Purl Stitch Knitting	
	* Cord Knitting	
	* Cable Pattern Knitting	
9.	Maintenance of the Machine	58
10.	How to Store the Machine	61
11.	How to Keep the Machine	65
12.	Standard Stitch Signs	66

TABLE OF CONTENTS

Parts Names

1 Parts Names 1
 * Main Body and Accessories 2
 2 How to Use Accessories 3
 3 How to Assemble the Machine 6
 4 How to Operate Carriage 9
 5 How to Operate Needle Selection Device 10
 * Automatic Needle Selection Using The Punch Card 14

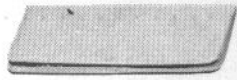

Accessory Bag



Pattern Plate (1x1)



Latch Needle (3 pcs)



Transfer Tool (1x2)



Transfer Tool (1x3)



Transfer Tool (2x3)



Crochet Needle



Latch Needle Tool

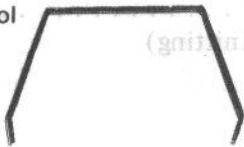

Punch Card Guide



Raveling Cord

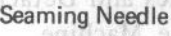

Seaming Needle



Brush



Carriage Lock



Knitting Weight

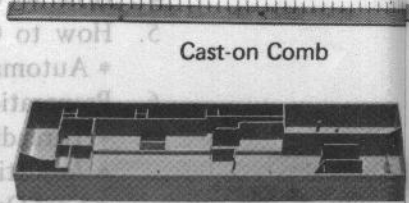

Cast-on Comb



Accessory Box



Fabric Presser



Oil Injector



Yarn Wax



Clamps (2)

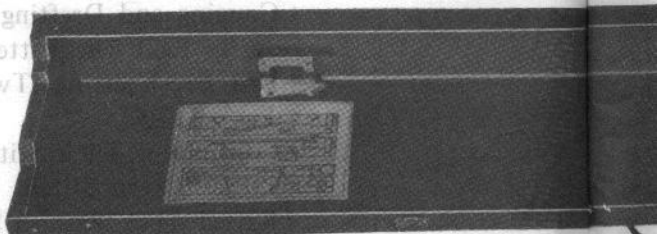







- Pattern Selector Buttons
- Row Counter
- Pattern Board
- Parts Box
- Latch Needle
- Needle Bed
- Yarn End Holder
- Sinker Hooks



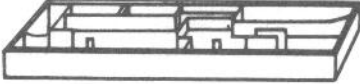
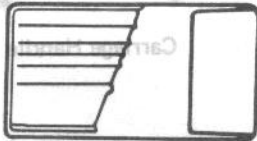
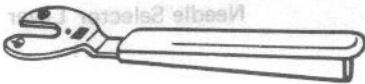

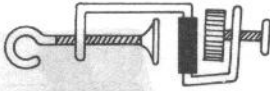

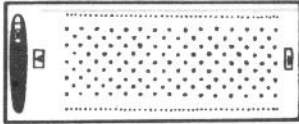

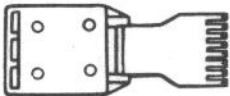
10 How to Store the Machine 28
 11 How to Keep the Machine 61
 12 Standard Stitch Signs 65





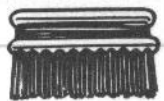

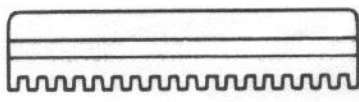
HOW TO USE ACCESSORIES

Part Name	Rough Sketch	Use
Accessory Box		Used for storing carriage handle, accessories, etc. while carrying the machine. Refer to Page 63.
Accessory Bag		Used for storing the latch needle tool and transfer tool.
Needle Selector Lever		By pulling it to the knob with two grooves at the left on the bottom of machine case and operating it, needle selection can be made.
Cast-on Comb		Used for casting on.
Clamps		Used for fixing the work.
Carriage Handle		Used for sliding.
Punch Card		Used for pattern knitting.
Punch Card Guide		Used for setting.
Knitting Weight		Used by hanging it from the carriage especially when lace yarn, thin yarn, etc. are knitted.
Carriage		
Pattern Book Stand		
Pattern Book		
Machine Case Complete		
Take-Up Spring		
Take-Up Rod		
Case Cover Complete		
Change Lever		
Card Dial		
Zig Zag Dial		

HOW TO USE ACCESSORIES

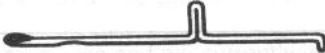
Parts Name	Rough Sketch	Use
Accessory Box		Used for storing carriage handle, accessories, etc. while carrying the machine. Refer to Page 63.
Accessory Bag		Used for storing the latch needle tool and transfer tool.
Needle Selector Lever		By setting it to the knob with two grooves at the left on the bottom of machine case and operating it, needle selection can be made.
Cast-on Comb		Used for casting on
Clamps		Used for fixing the machine to knitting stand, etc.
Carriage Handle		Used for sliding the carriage.
Punch Card		Used for pattern knitting
Punch Card Guide		Used for setting the punch card.
Knitting Weight		Used by hanging it to both ends of fabric especially when lace yarn, thin yarn, etc. are knitted.

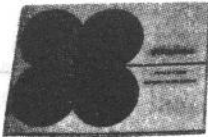
Parts Name	Rough Sketch	Use
Transfer Tool (1 x 2)		Used when increasing, decreasing or transferring less than 3 stitches and knitting patterns (lace pattern), etc.
Transfer Tool (2 x 3)		Used when increasing, decreasing or transferring less than 4 stitches and knitting patterns (lace pattern), etc.
Transfer Tool (1 x 3)		The same use as the above.
Latch Needle Tool		Used when making rib stitch or purl stitch in the waist or sleeve end of garments.
Crochet Needle		Used for crochet at the edge of sweater.
Brush		Used for raising up the latches.
Raveling Cord		Used for dividing garment knitting from waste knitting.
Pattern Plate (1 x 1)		Used when moving needles to the working position, returning them to the rest position or making the needle selection 1:1.
Seaming Needle		Used when seaming the fabrics

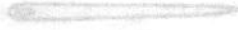
Parts Name	Rough Sketch	Use
Carriage Lock		Be sure to use this to lock the carriage when carrying the machine.
Oil Injector		For smooth carriage movement, apply oil with brush to the butt of needles and cams in the carriage.
Pattern Book Stand		Used for Standing the Pattern Book on the Machine
Latch Needle		After using the machine, examine needles and replace bent and worn ones with new ones.
Yarn Wax		Used by attaching to the take-up rod when using very thin yarn, lace yarn or summer yarn.
Pattern Book		Used for pattern knitting when using punch card.
Raveling Cord		Used for dividing garment knitting from waste knitting.
Pattern Plate		Used when moving needles to the working position, returning them to the rest position or making the needle selection 1:1.
Sewing Needle		Used when sewing the fabric of garments.

HOW TO ASSEMBLE THE MACHINE

Remove the tape and the stop pin from the underside of the machine case.



Fig. 2

Release the two catch locks.

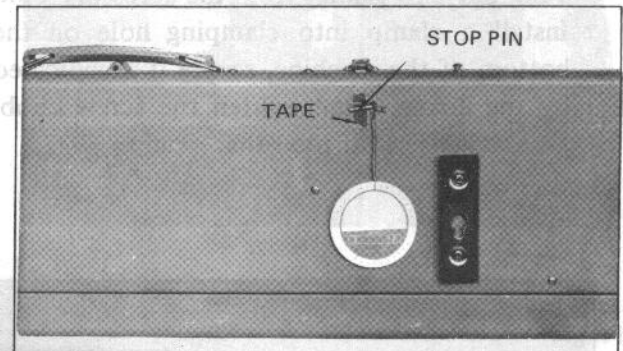

Fig. 1

Place the case on the table so that the case handle opposite you.

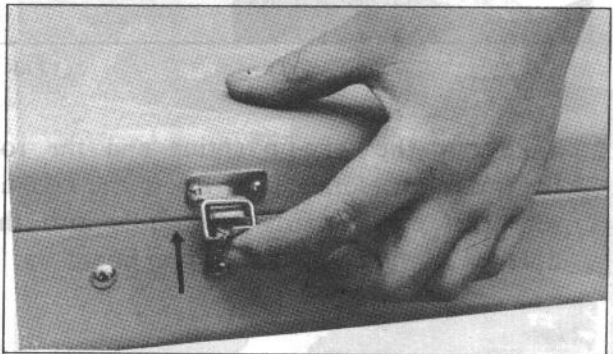

Fig. 3



Fig. 4

Remove the accessory box by lifting with both hands.

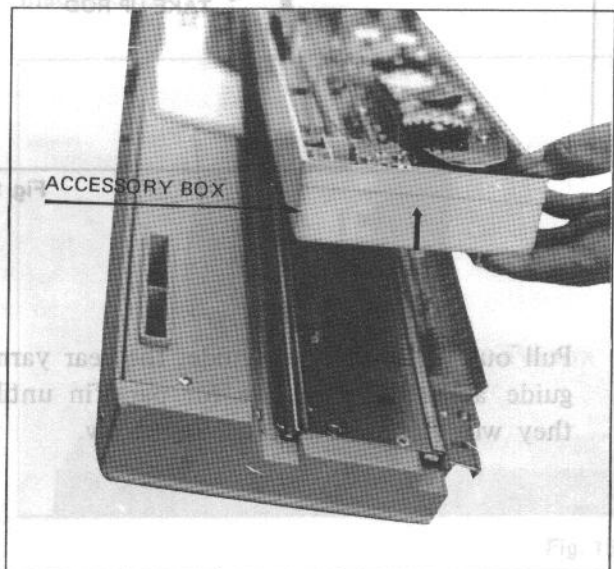

Fig. 5

Take out two clamps from the accessory box. Install a clamp into clamping hole on the bottom of the machine, secure it as indicated by the arrow. Then tighten the screw knob. Do the same with the other clamp.

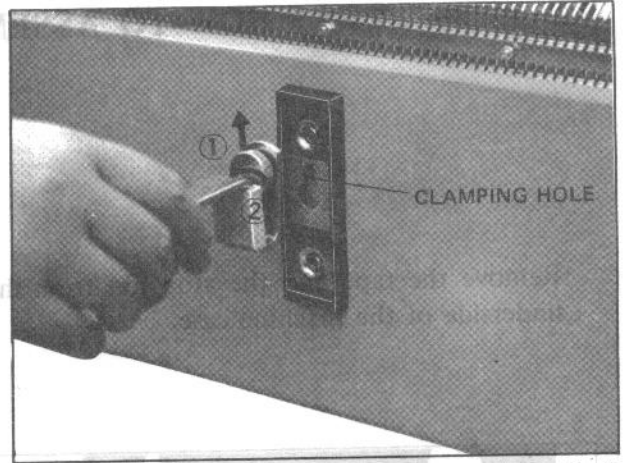

Fig. 6

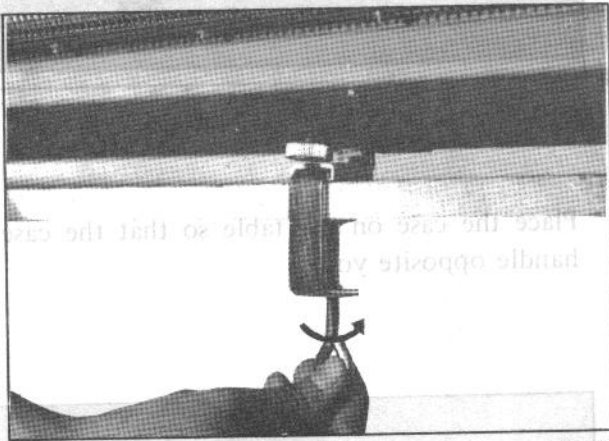

Fig. 7

Secure the machine on the table.

Take out the take-up spring and the rod from the accessories box. Insert the take-up rod with curved part downwards into the hole on the pattern indication board.

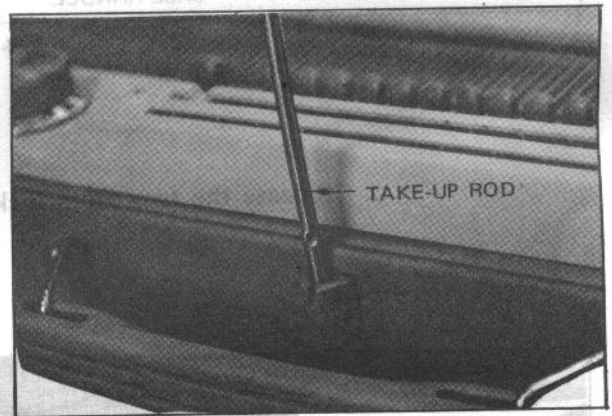

Fig. 8

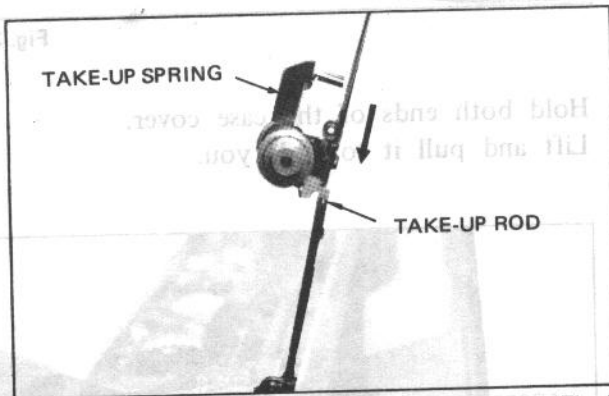

Fig. 9

Insert the take-up spring on the tip of the take-up rod.

Pull out the front yarn guide, the rear yarn guide and the base plate for paraffin until they will stop, as indicated by arrow.

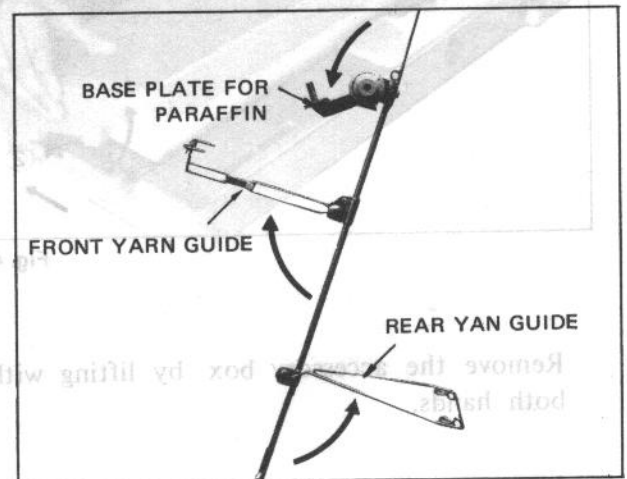

Fig. 10

HOW TO OPERATE CARRIAGE

Detach the carriage lock from the carriage ▶ in order (1-2-3) as shown in Fig. 11.

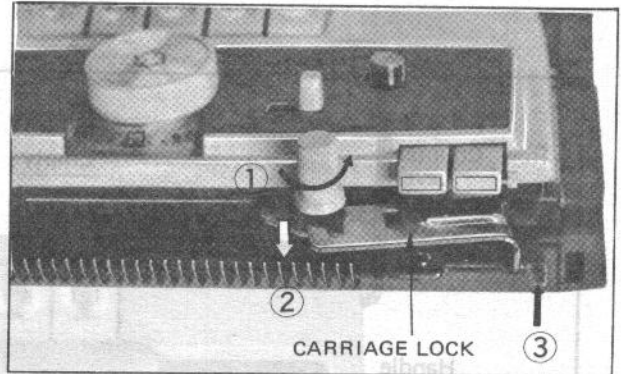

Fig. 11

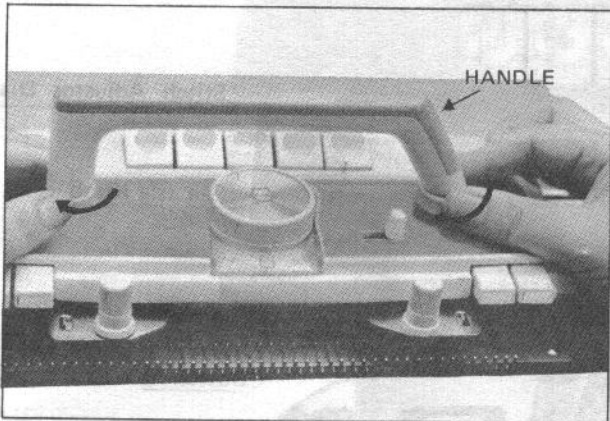

Fig. 12

▶ Take the handle out of the accessory box. Attach it to the carriage by turning the right and left screws simultaneously.

▶ Take out the fabric presser from the accessory box and install it to the carriage. Loosen the fabric presser screw knobs on the carriage and push the fabric presser as indicated by the arrow (1) so that the stopper fits into the stopper hole of the presser. Pull the presser as indicated by the arrow (2) and tighten the screw knobs.

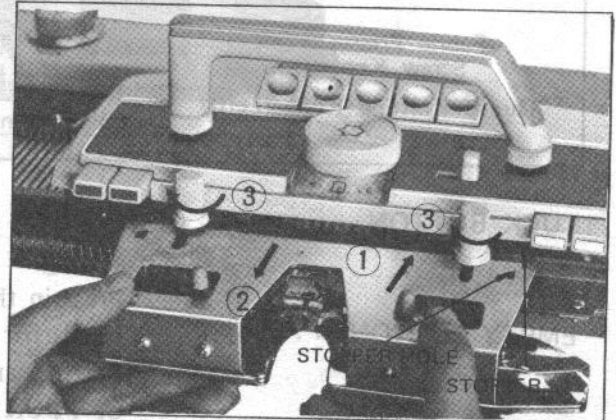

Fig. 13

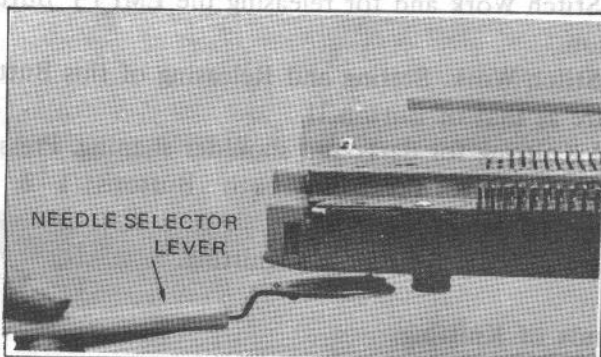

Fig. 14

▶ Take out the needle selector lever from the accessory box and install it to the knob with two grooves at the left on the bottom of the machine case.

▶ Fix latch transfer tool, latch needle tool, etc. into the parts box.

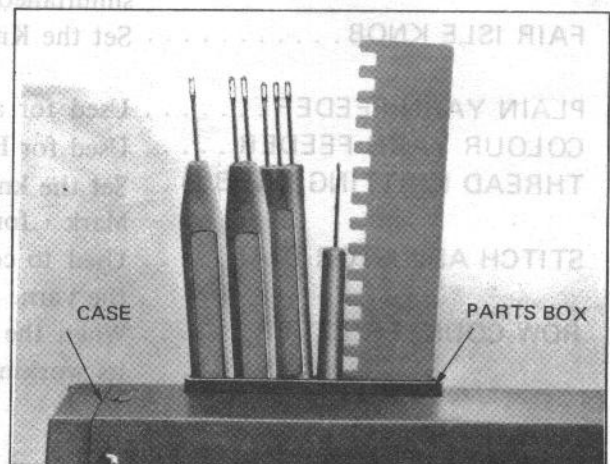
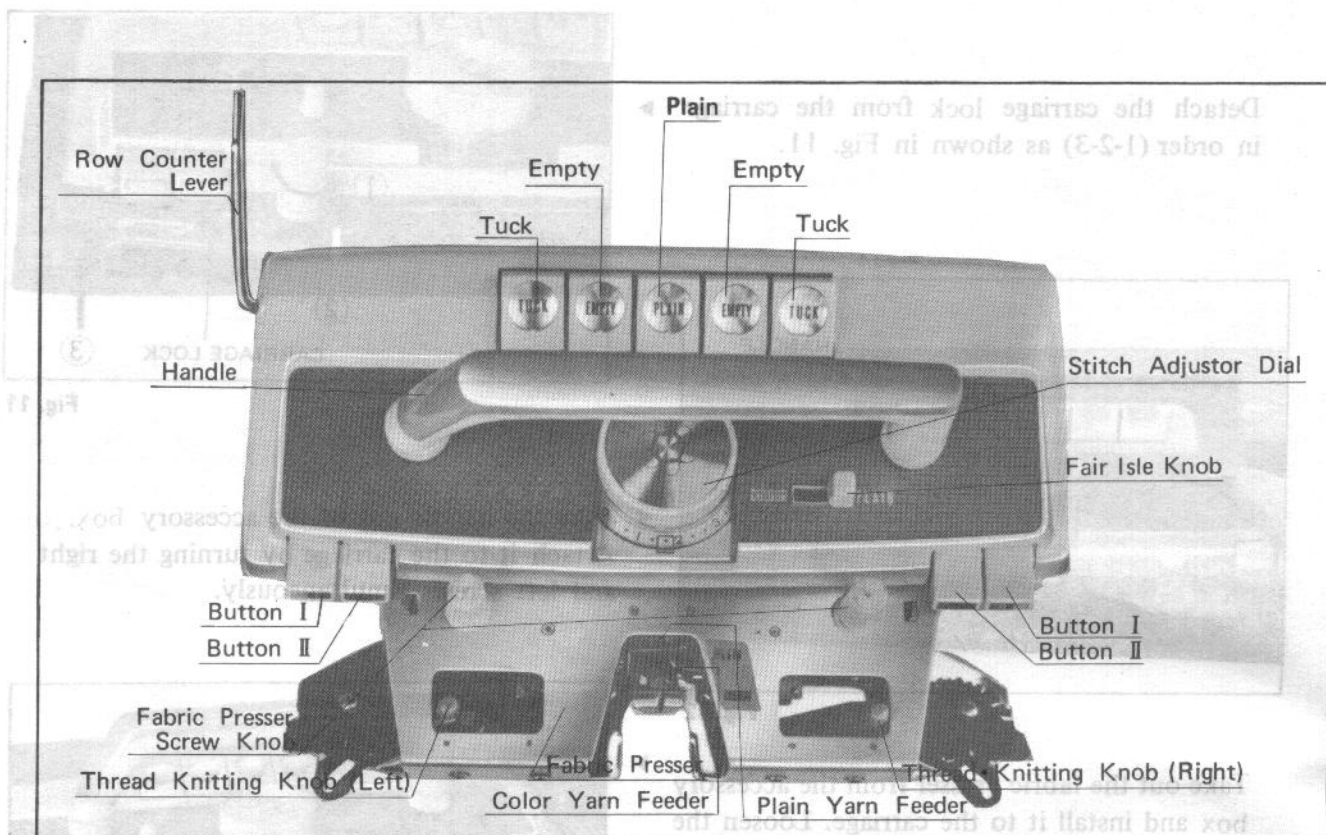

Fig. 15

HOW TO OPERATE CARRIAGE



TUCK BUTTON Used for Tuck Stitch knitting. Press in the TUCK Button for setting.

EMPTY BUTTON Used for Slip Loop Tuck Colour Combination Stitch Work. Setting and Releasing of this Button is same procedure as that of TUCK Button.

PLAIN BUTTON Used for Plain Stitch Work and for releasing the EMPTY Button and TUCK Button.

BUTTON I Used for Tuck Stitch Work. Setting and Releasing of this Button is same procedure as that of Button II.

BUTTON II Used for Partial Knitting for darts and shoulder shaping. Press in the Button for setting. Press in both Buttons I & II simultaneously for releasing.

FAIR ISLE KNOB Set the Knob at COLOUR for Fair-isle Knitting.

PLAIN YARN FEEDER Used for all kinds of Knitting.

COLOUR YARN FEEDER Used for Fair-isle Knitting.

THREAD KNITTING KNOB Set the knob at Red Mark • for Thread knitting and set at Black Mark • for all other knitting.

STITCH ADJUSTOR DIAL Used to control the size of stitches according to the thickness of the yarn.

ROW COUNTER LEVER When the row counter is required, the lever should be turned to its working position.

Fig. 18

HOW TO OPERATE NEEDLE SELECTION DEVICE

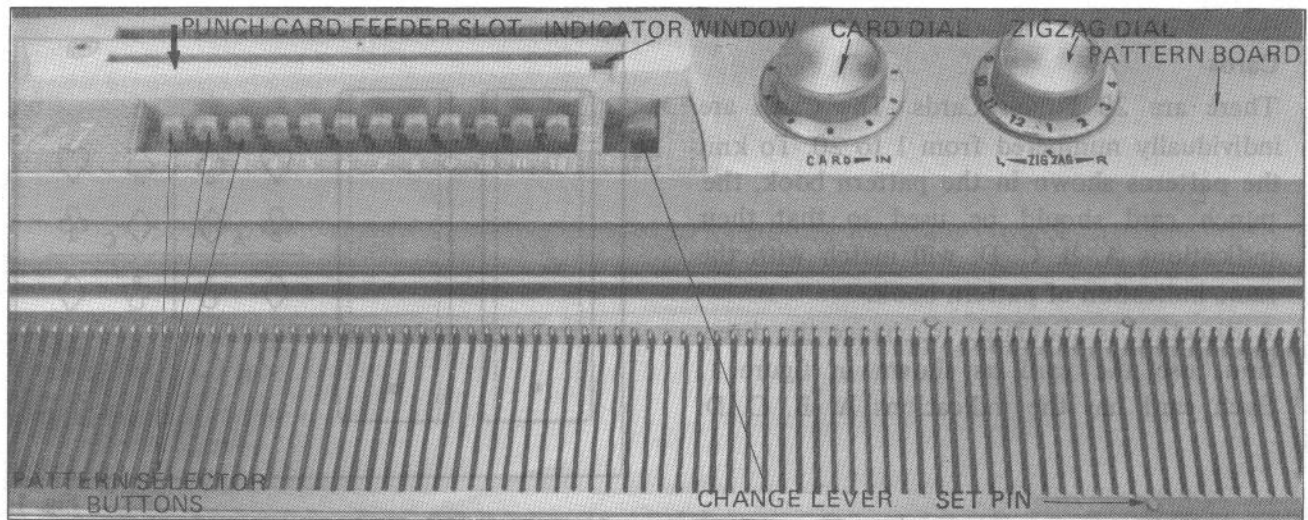

- PATTERN SELECTOR BUTTONS** · Used for Manual needle selecting.
- CHANGE LEVER** · Change Lever can be set at AUTO, MANUAL and RETURN.
- AUTO** · Change Lever should be set at AUTO position when the punch card is used.
- MANUAL** · Change Lever should be set at MANUAL position when punch card is not used.
- RETURN** · When selecting needles manually, pull out the change lever to RETURN position so that the pattern selector buttons are returned. When the pattern selector lever is returned, release the change lever and change lever will be returned to its original position automatically.
- CARD DIAL** · Used for feeding the punch card.
- Turn the dial anti-clockwise when inserting the punch card into the feeder slot.
- When reversing the punch card, the change lever should be set at **MANUAL**. Turn the card dial clockwise so that the card can be fed back.
- ZIGZAG DIAL** · Used for changing and centering patterns.
- The same number shown on the zigzag dial must be set on the center mark on the pattern board.
- PUNCH CARD FEEDER** · Put the punch card into the front punch card feeder slot so that the card will come out of the back slot.
- NEEDLE SELECTOR LEVER** · Move lever to right as far as possible, then return as far as possible. When using the punch cards, the card will drop down one position when the lever is returned completely.

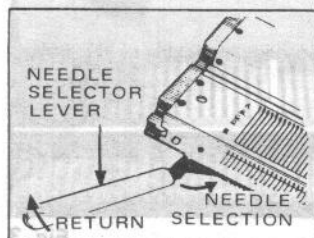

AUTOMATIC NEEDLE SELECTION USING THE PUNCH CARD

Cards

There are 20 Punch Cards. The Cards are individually numbered from 1 to 20. To knit the patterns shown in the pattern book, the punch card should be used so that their indications A. B. C. D. will match with the same indication of pattern book.

A direction is standard: to change the direction, use the card as shown in figure 1. Each card has the indications A. B. C. D.

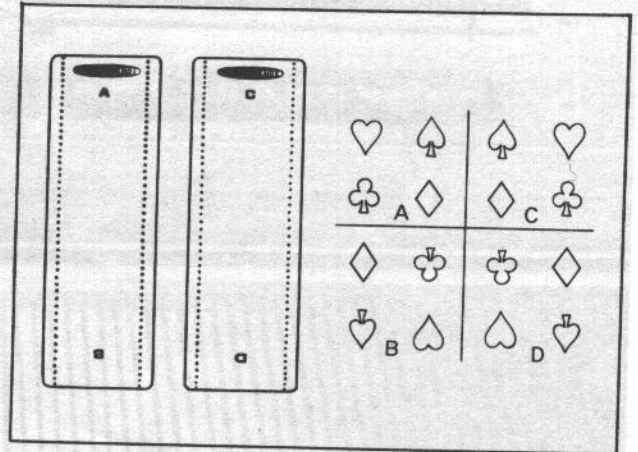

Fig. 1

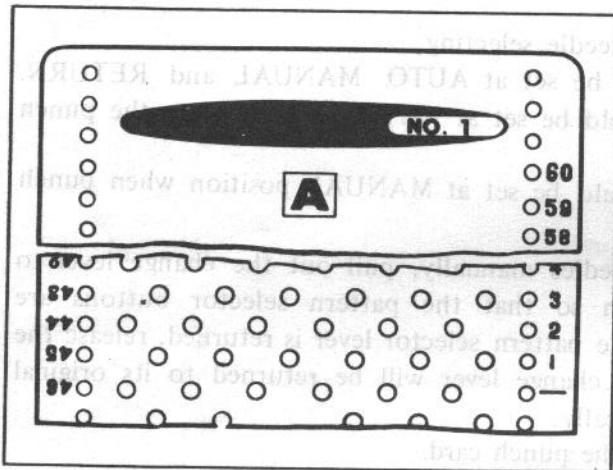

Fig. 2

The number of rows for each pattern is indicated on the right side of the punch card.

Red Mark - on the card shows the setting position to the machine. In order to make the same pattern repeatedly, the card should feed back to Red Mark -.

The cards No. 8, 9, 10, 11, 12, 14, 15, 18 and 20, have the row when no needle is selected after finishing one pattern, even if the needle selector lever is turned.

At this position, knitting of one pattern is finished, and you may continue in plain stitch for the required number of rows without turning the needle selector lever before repeating the pattern. In case plain stitch is not required, turn the needle selector lever again and continue knitting in pattern.

HOW TO USE THE PUNCH CARDS

Push the needles out from A position to B position.

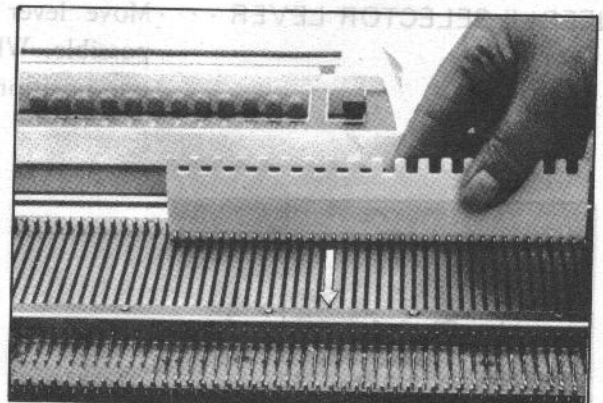

Fig. 3

Set the zigzag dial at 1. (Position of the pattern can be adjusted by zigzag dial.)

To adjust the center of the pattern to center of the machine, set the zigzag dial at 7.

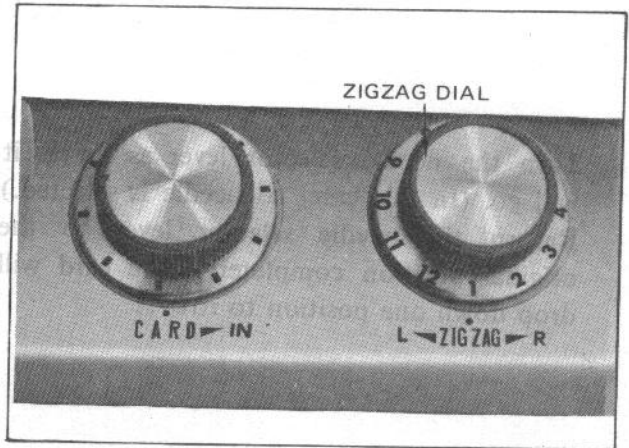

Fig. 4

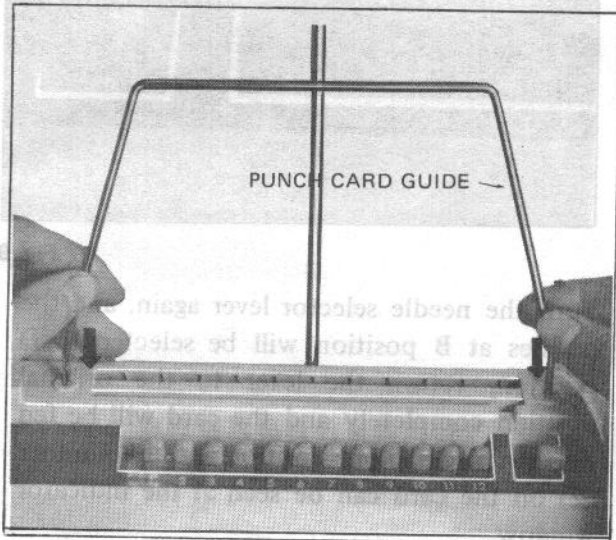

Fig. 5

Put the punch card in the front punch card feeder behind the punch card guide so that the base line of the card is in exact alignment with the surface of the pattern board.

Set the punch card guide on the pattern board.

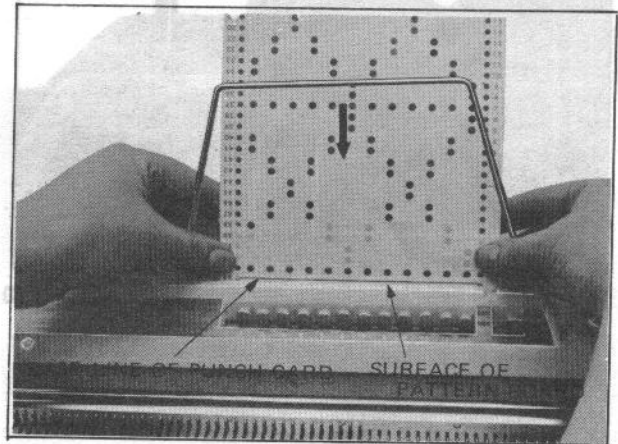

Fig. 6

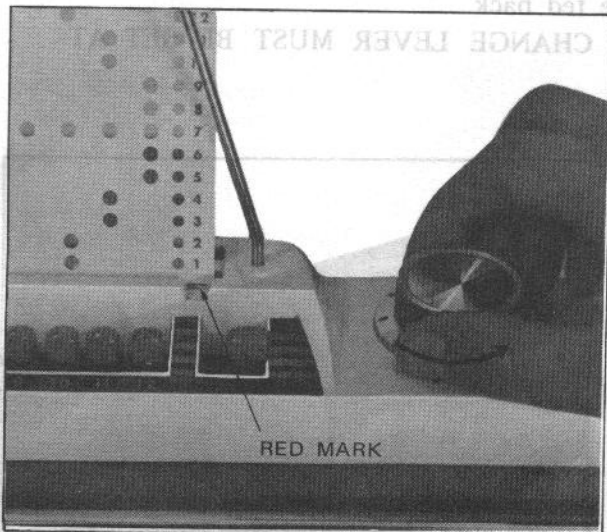

Fig. 7

Set the change lever at AUTO position.

Turn the card dial to the direction of IN mark and set the red mark of punch card to the card feed indicator window.

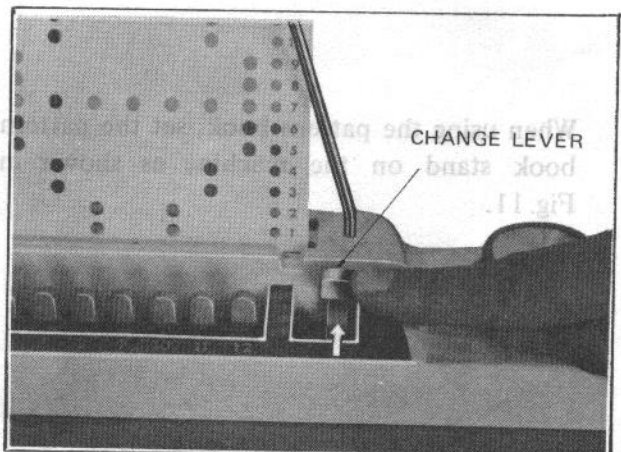
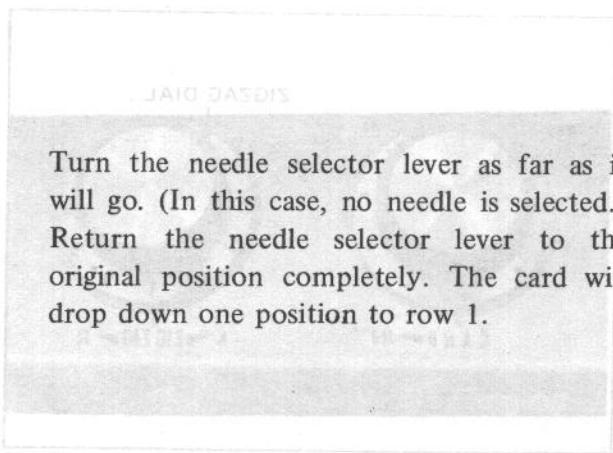

Fig. 8



Turn the needle selector lever as far as it will go. (In this case, no needle is selected.) Return the needle selector lever to the original position completely. The card will drop down one position to row 1.

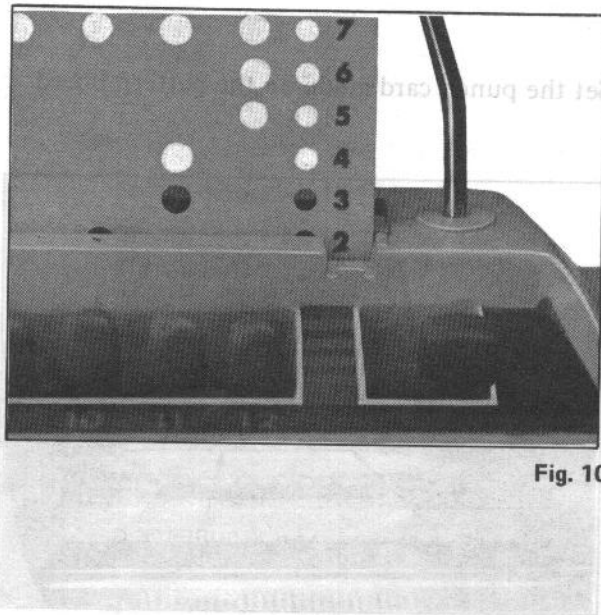

Fig. 10

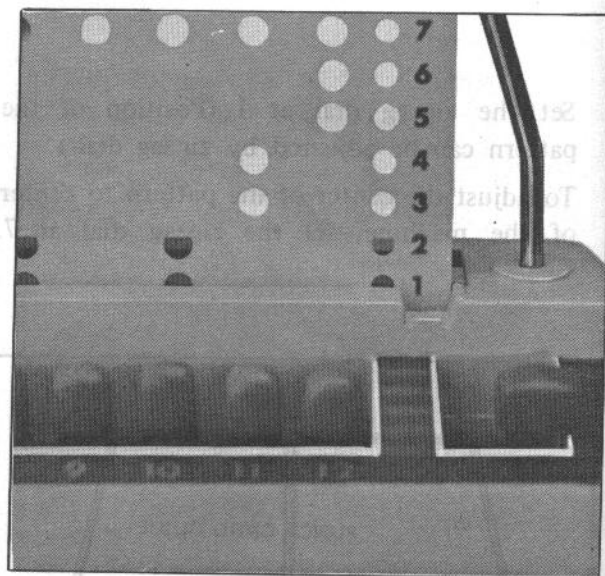

Fig. 9

Turn the needle selector lever again, and the needles at B position will be selected to D position, return the lever to the original position completely and the card will be fed into the machine one position and the number (2) on the card can be seen at the indicator window.

Slide the carriage once either to the left or right side.

*By turning the selector lever, the needles will be selected according to the pattern of the card.

If feed back of the card is required halfway, set the change lever at MANUAL position and turn the dial clockwise so that the card can be fed back.

AFTER FEEDING BACK THE CARD, THE CHANGE LEVER MUST BE SET AT (AUTO) POSITION AGAIN.

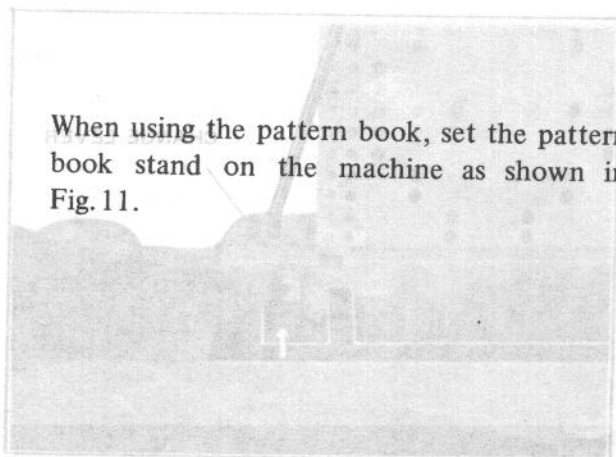

Fig. 8

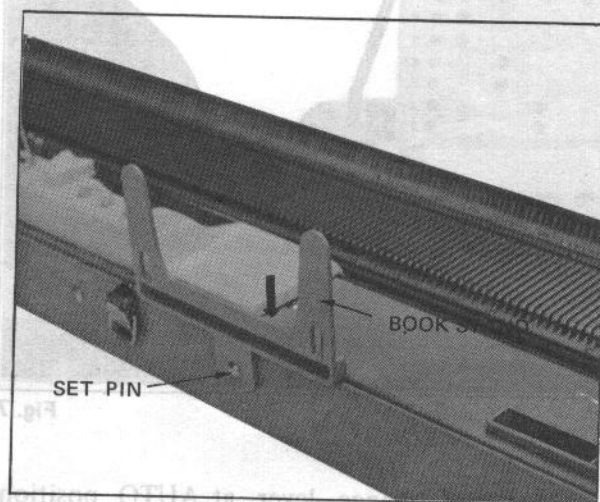

Fig. 11

PREPARATION BEFORE KNITTING

Yarn must feed smoothly without restriction, so rewind on to cones or use a ball winder and feed the yarn from the center.

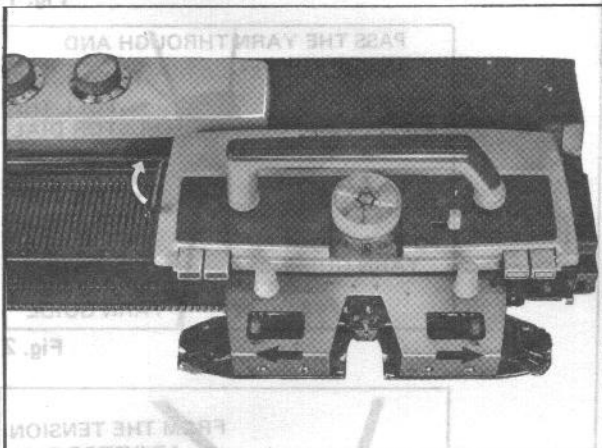

Fig. 2

Set the stitch adjustor dial to "5" for three ply yarn, "7" for four ply yarn.
 Note: Stitch Adjustor Dial controls the size of stitches and is adjusted according to the thickness of the yarn.

The greater the number, the bigger the stitches.

Use the table below for reference.

Stitch Size	1 - 3	3 - 6
Yarn Size	Two ply	Three ply
Stitch Size	6 - 9	8 - 10
Yarn Size	Four ply	Double Knitting

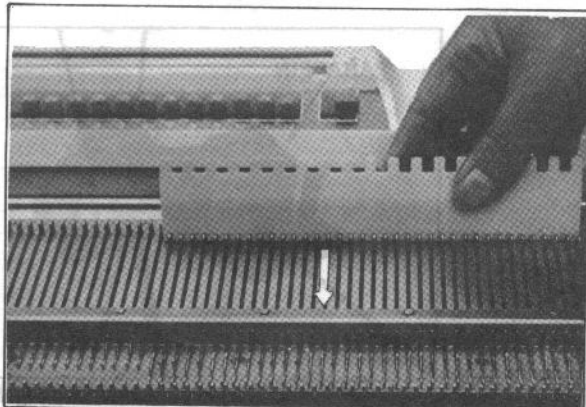

Fig. 4

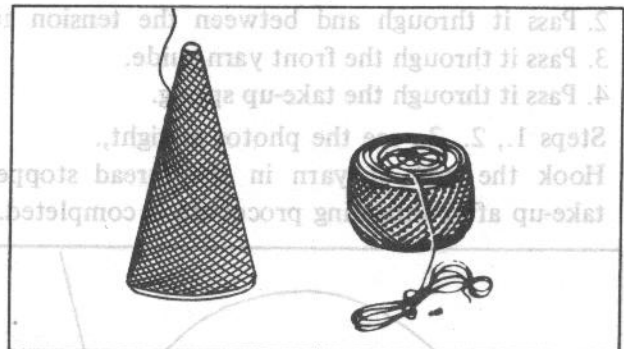

Fig. 1

- Install the carriage to the right side of the needle bed. (The carriage is set for plain stitch when any buttons are not pushed in). Pull out the row counter lever, as indicated by the arrow, if you want to use the row counter.

Set the thread knitting knobs at black mark.

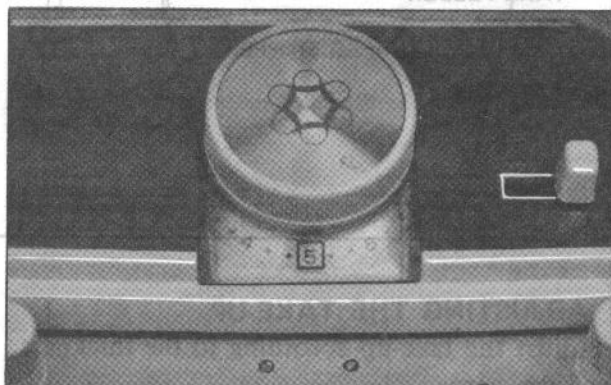
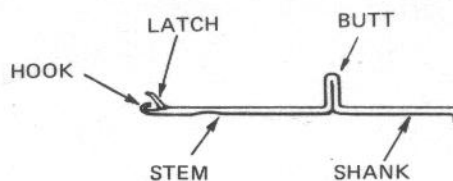

Fig. 3

- By using the pattern plate move the desired number of needles from A to B position indicated on both ends of the needle bed. (A, B, C, D mark at both ends of the needle bed indicate the position of the needle butt).
 Needles should always be selected in the center of the machine, using the numbers marked on the bed by needle tip.



PREPARATION BEFORE KNITTING THREADING MACHINE.

1. Pass the yarn through the rear yarn guide.
2. Pass it through and between the tension adjustor dials.
3. Pass it through the front yarn guide.
4. Pass it through the take-up spring.

Steps 1., 2., 3., see the photos at right.

Hook the end of yarn in the thread stopper to adjust take-up after threading procedure is completed.

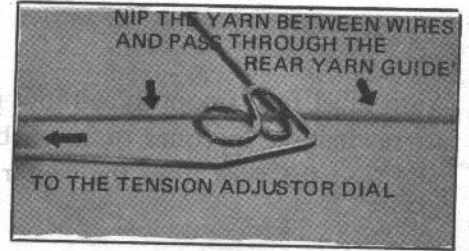

Fig. 1

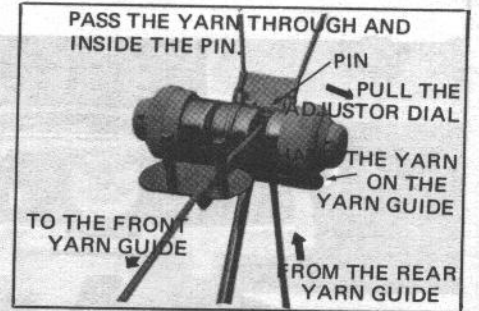

Fig. 2

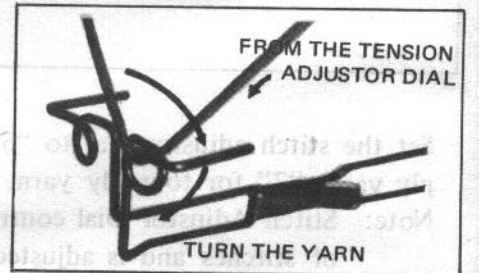

Fig. 3

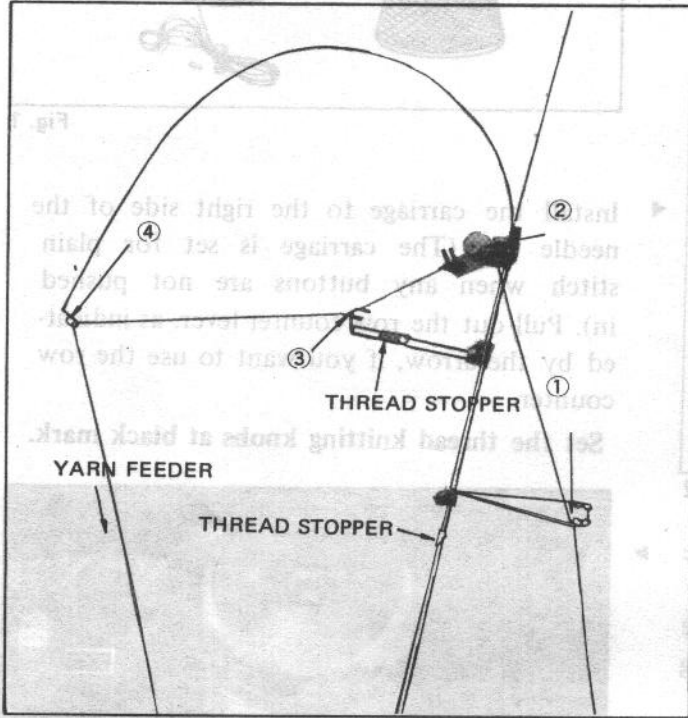

Fig. 4

ADJUSTING THE TAKE-UP

Adjust the take-up according to the thickness of the yarn.

Adjust the dial so that the end of the take up spring and the front yarn guide will be same height when the yarn is passed through. Yarn becomes tighter when the dial is turned clockwise.

When three ply yarn is used, set the red line to mark - on the dial. When a thinner yarn than three ply is used, set the red line to mark (+). When a heavier yarn than three ply is used, set the red line to mark (-). Please use wax, when using rough yarn such as nylon, synthetic yarns and cotton yarns. Thread waste yarn similarly through left hand feed.

3-6	1-3	Switch Size
Three ply	Two ply	Yarn Size
8-10	6-9	Switch Size
Double Knitting	Four ply	Yarn Size

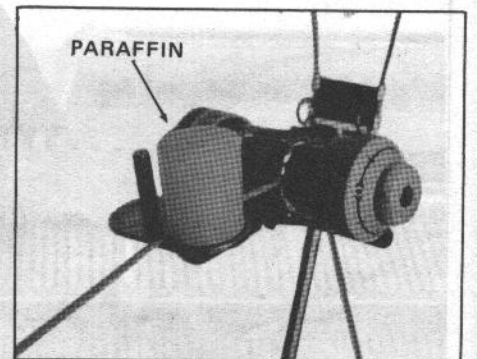
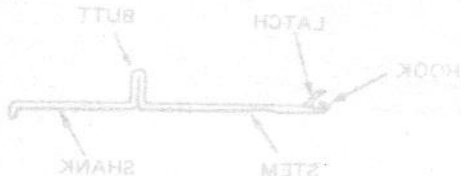

Fig. 5



Detach the waste yarn from the thread stopper and pass it through the plain yarn feeder.

HOW TO PASS THE YARN THROUGH THE PLAIN YARN FEEDER

Stretching the yarn up and down, push into the lower spring and to the rear and then pass it behind the upper spring.

Do not knit before checking that the yarn is behind the lower spring.

HOW TO DETACH THE YARN FROM THE PLAIN YARN FEEDER

After detaching the yarn from the upper spring, detach it from the lower spring pulling it in the direction shown by arrow.

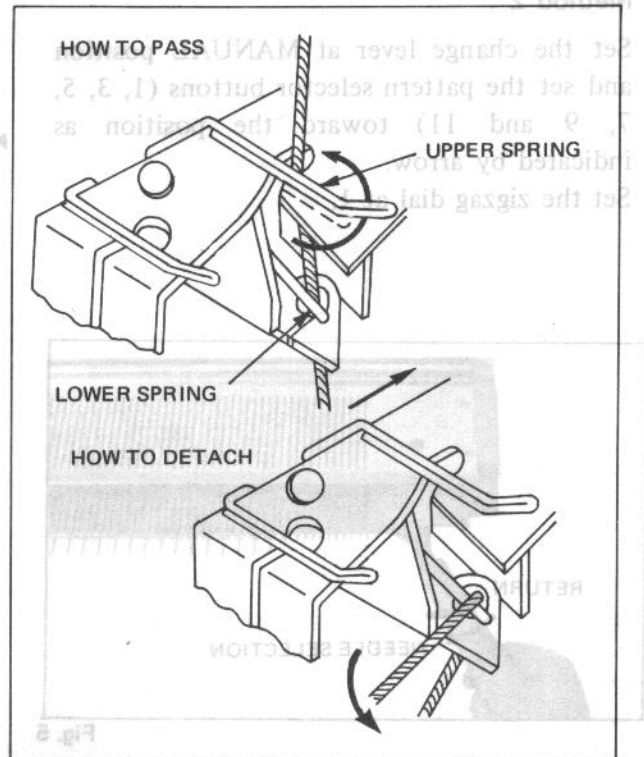
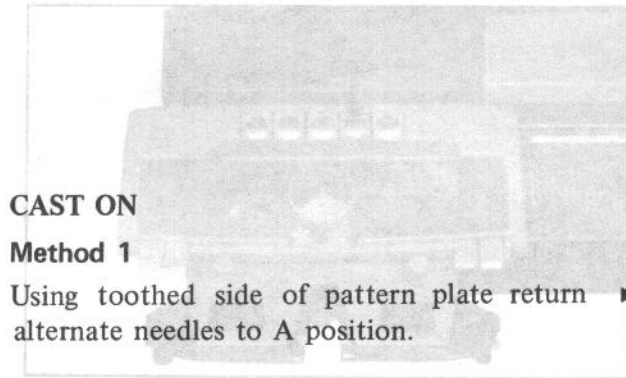

Fig. 6



CAST ON

Method 1

Using toothed side of pattern plate return alternate needles to A position.

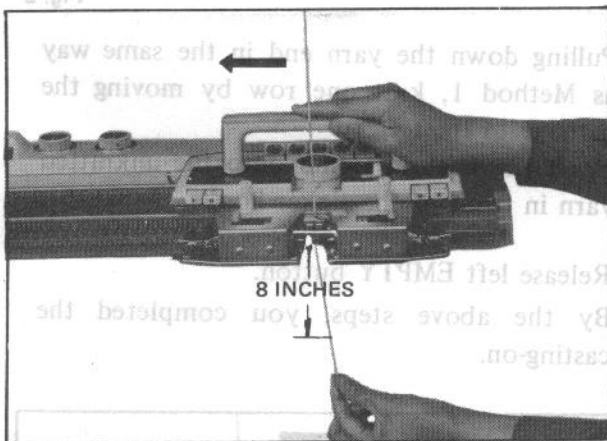

Fig. 2

Yarn will pass over every second needle. Hook the cast-on comb onto the unknitted yarn in front of the sinker hooks.

Bring forward the alternate empty needles from A to B position and knit back.

By the above steps, you completed the casting-on.

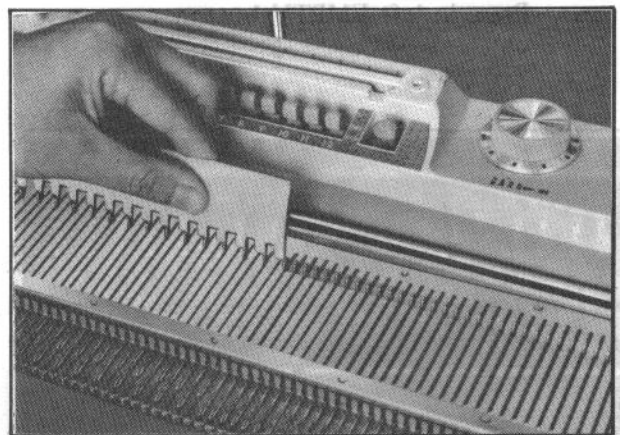

Fig. 1

All buttons neutral

Pull down about 8 inches of the yarn end from the yarn feeder, hold it with one hand and knit one row by moving the carriage to the left.

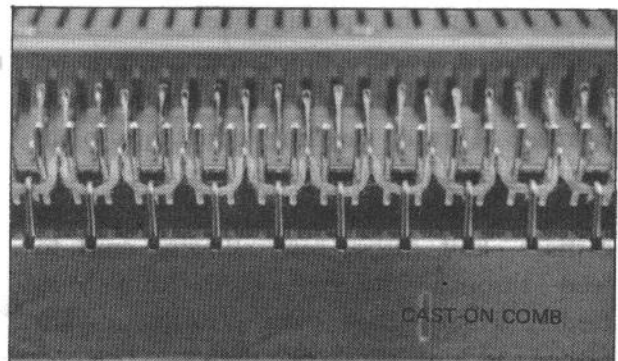

Fig. 3

Method 2

Set the change lever at **MANUAL** position and set the pattern selector buttons (1, 3, 5, 7, 9 and 11) toward the position as indicated by arrow.

Set the zigzag dial at 1.

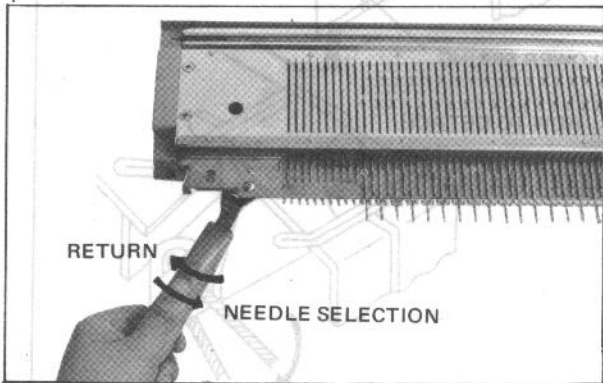

Fig. 5

Press in left **EMPTY** button.

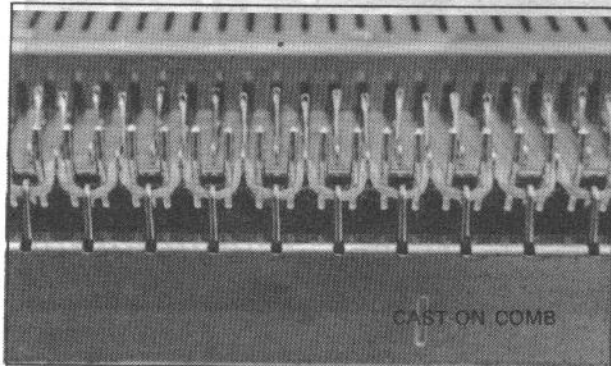

Fig. 7

Continue knitting by moving the carriage to the right and left.

The carriage should be moved toward one side until a click can be heard and then moved toward the opposite side.

Knit several rows ending with carriage on right. Break off waste yarn, and remove from carriage. Thread raveling cord into plain yarn feeder, short end below carriage.

Holding remainder of cord loosely above carriage, knit across row, allowing cord to feed through. Remove cord from yarn feeder. Thread base yarn into plain yarn feeder and knit hem as required.

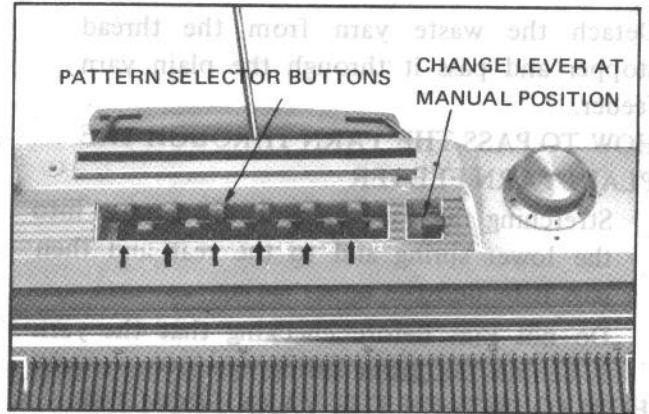

Fig. 4

Turn the needle selector lever as far as it will go and return it to the original position completely. Every alternate needles will move from B to D position.

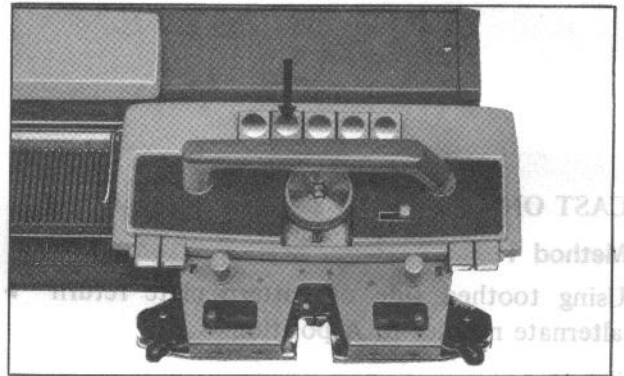

Fig. 6

Pulling down the yarn end in the same way as Method 1, knit one row by moving the carriage to the left.

Hook the Cast-on Comb onto the unknitted yarn in front of the sinker hooks.

Release left **EMPTY** button.

By the above steps, you completed the casting-on.

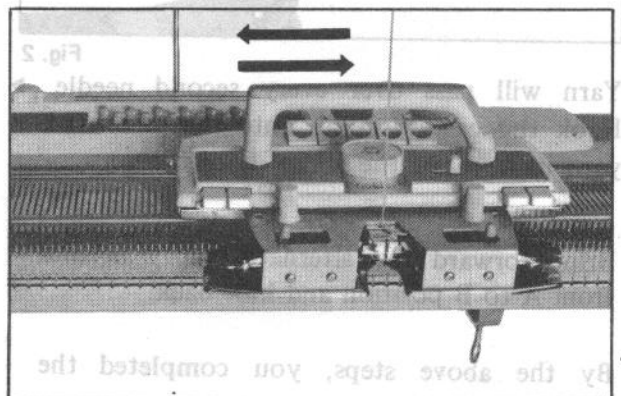

Fig. 8

GUIDE FOR KNITTING

TURNED-UP HEM KNITTING

PLAIN HEM

1. Thread in base yarn. Set tension to 4, row counter 000.
2. Knit twice depth required, finishing with carriage on left. (Fig. 1)
3. Using transfer tool, pick up base yarn loops next to the ravelling cord and hang on opposite needles. (Fig. 2)
4. Set tension to 7 and knit back. Pull out ravelling cord side-ways and discard waste knitting. Row counter 000.

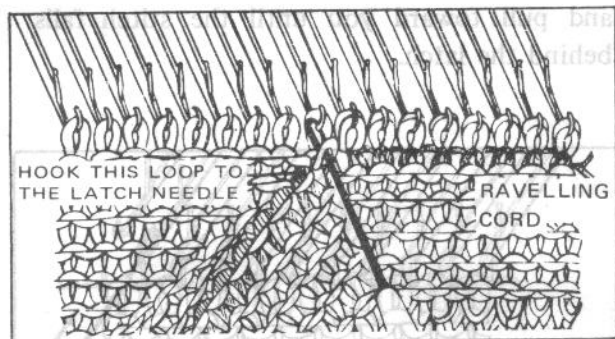

Fig. 2

HEM WITH PICOT EDGE

1. Follow instructions for cast on. Thread in base yarn, tension 4.
2. Knit depth required (say 12 rows.)
3. Set pattern selector buttons 1, 3, 5, 7, 9, 11 and rack up this selection using needle selector lever.
4. Using one eye Transfer Tool, transfer the loops of selected needles to the next needles. (Fig. 3)
5. Knit 13 rows. (or 1 more than original depth.) carriage on left.
6. Follow Plain Hem instructions 3 and 4. (Fig. 4)

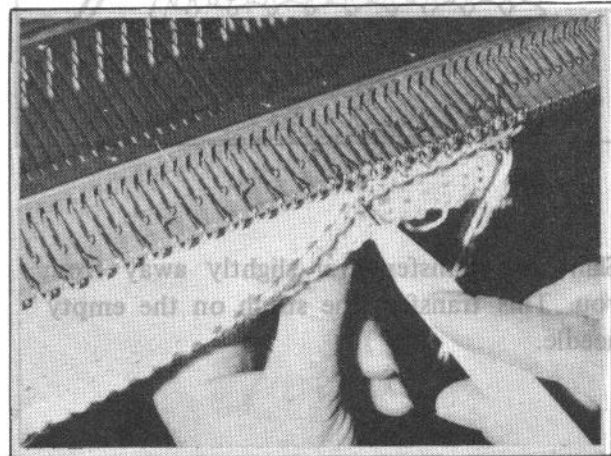

Fig. 5

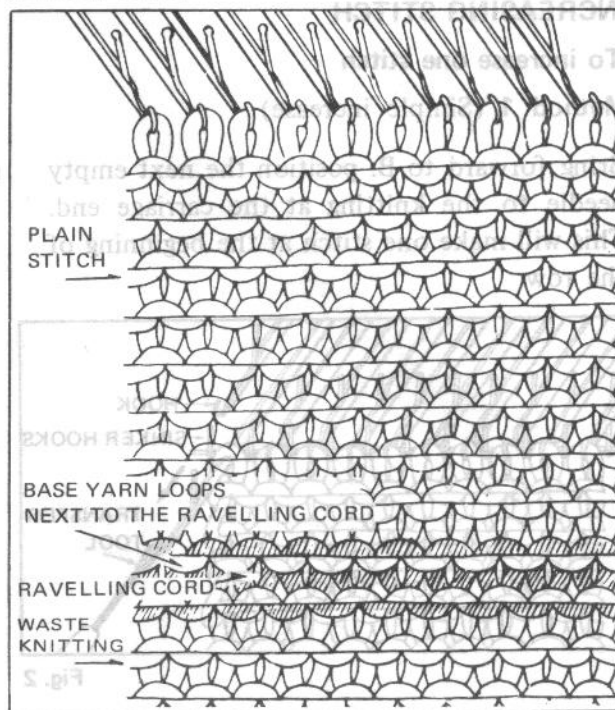

Fig. 1

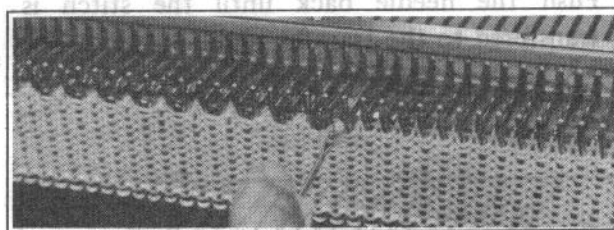

Fig. 3

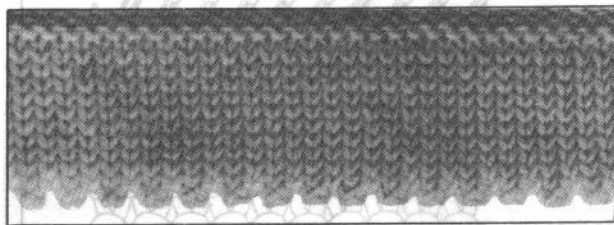

Fig. 4

MOCK RIB, using alternate needles.

1. Using waste yarn, cast on over alternate needles only.
2. Knit 6 rows. Carriage on left. Break off waste yarn.
3. Thread in ravelling cord and knit 1 row.
4. Unthread ravelling cord, thread in base yarn. Set tension to 3, and knit twice the depth required, finishing with carriage on left.
5. Using transfer tool, pick up the base yarn loops next to the ravelling cord, and hang on the empty needles, pulling them through to B position. (Fig. 5)
6. Set tension to 7 and knit back.
7. Pull out ravelling cord sideways and discard waste knitting. Row counter 000.

INCREASING STITCH

To increase one stitch

Method 1 (Simple increase)

Bring forward to B. position the next empty needle to the knitting at the carriage end. This will make one stitch at the beginning of the row.

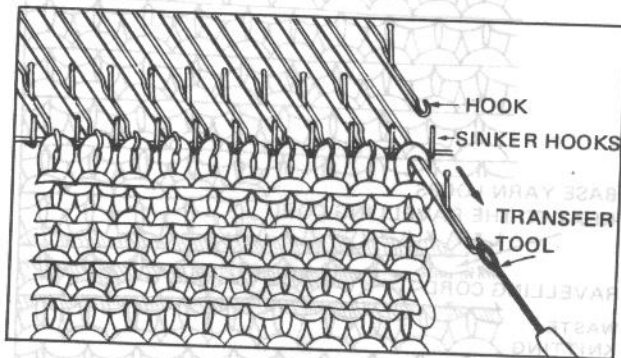

Fig. 2

Push the needle back until the stitch is transferred to the transfer tool

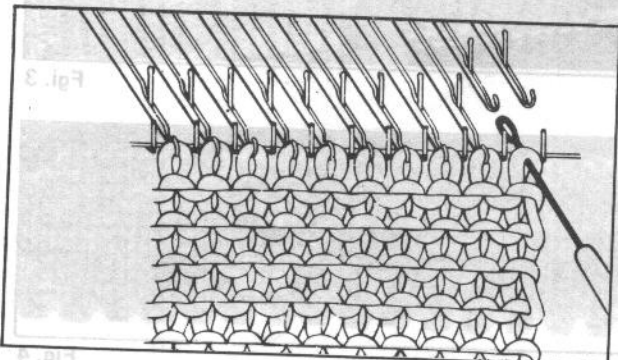

Fig. 4

Hook the transfer tool to the next latch needle by moving the tool as indicated by arrow (1) and then pull it out slightly arrow (2).

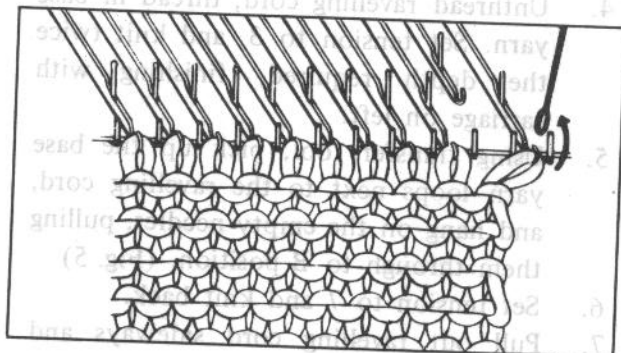

Fig. 6

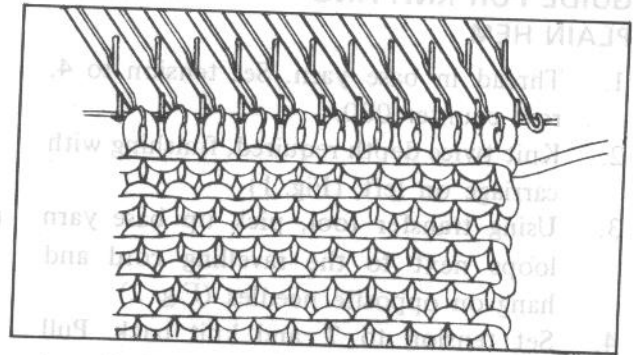

Fig. 1

Method 2

Hook the transfer tool on the end needle and pull toward you until the stitch falls behind the latch.

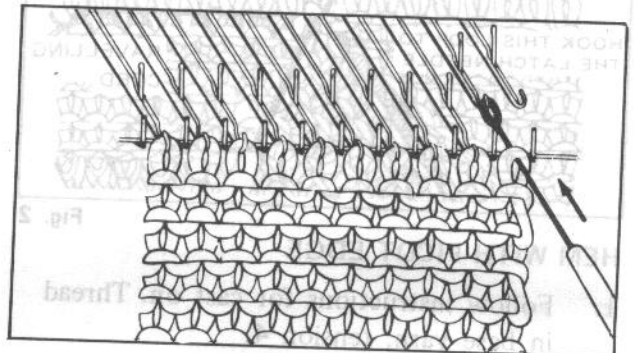

Fig. 3

Unhook the transfer tool carefully not to drop the transferred stitch.

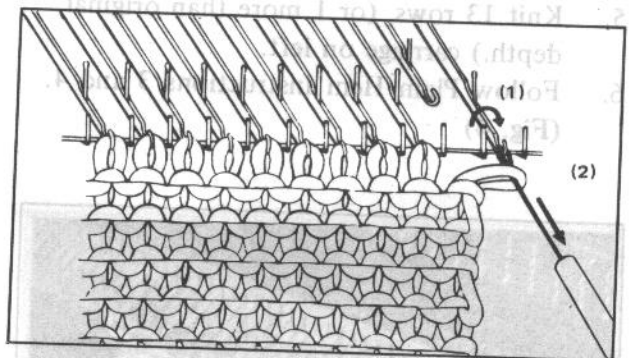
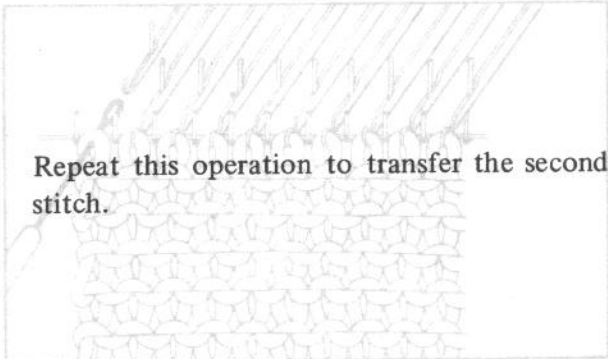

Fig. 5

Slant the transfer tool slightly away from you. This transfers the stitch on the empty needle.



Repeat this operation to transfer the second stitch.

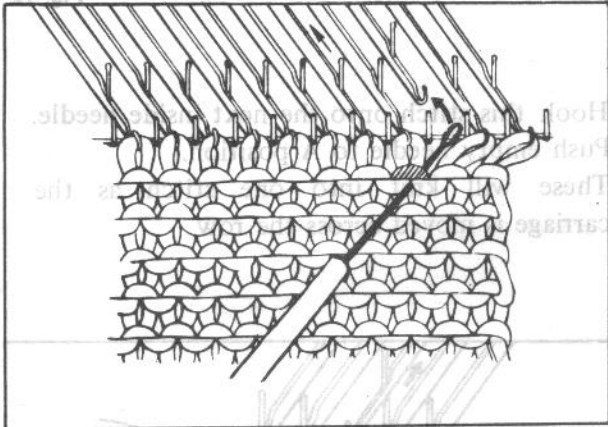

Fig. 8

To increase more than 2 stitches.

Pull out the required number of needles, next to the yarn end, to E position.

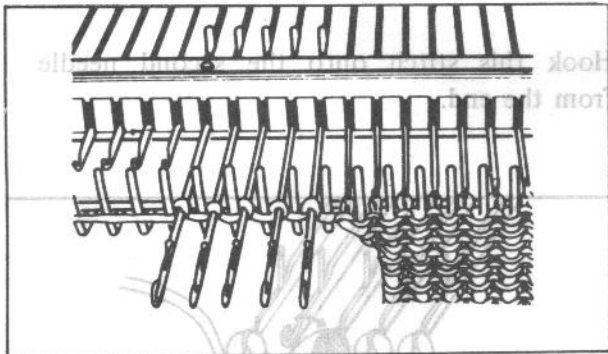

Fig. 10

Knit one row.

While knitting 3-4 rows, pull out the needles wound with yarn to E position in every row knitted.

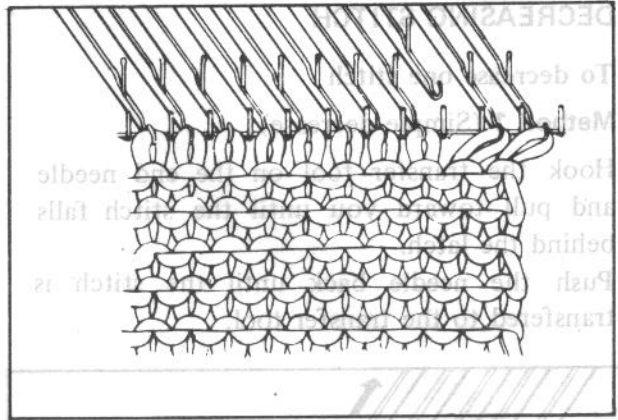

Fig. 7

Pick up the stitch on the second row of the third stitches (oblique stitch shown in Fig. 8) and transfer it to the empty needle. This increases one stitch.

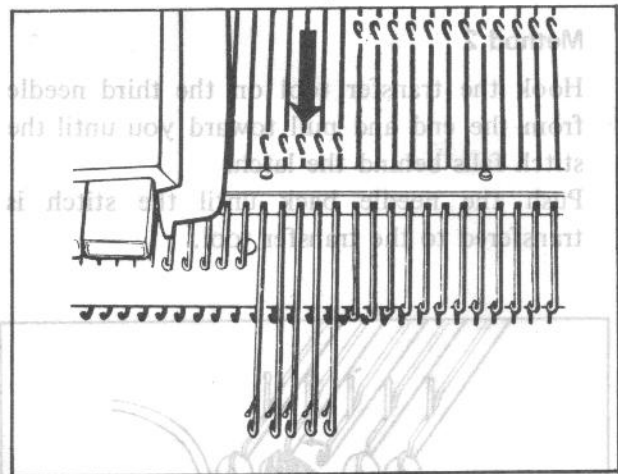

Fig. 9

Wind the yarn round the respective needles pulled out to E position as shown in Fig. 10

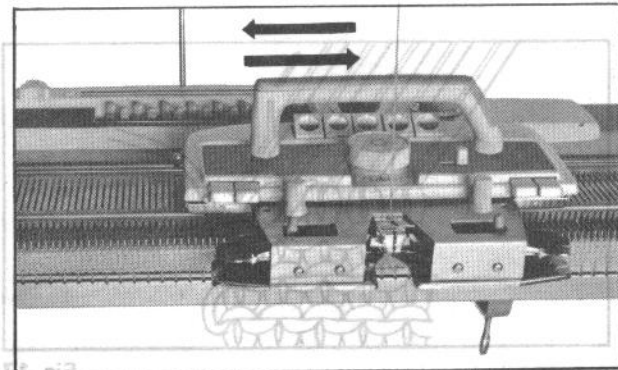

Fig. 11

DECREASING STITCH

To decrease one stitch

Method 1 (Simple decrease)

Hook the transfer tool on the end needle and pull toward you until the stitch falls behind the latch.

Push the needle back until the stitch is transferred to the transfer tool.

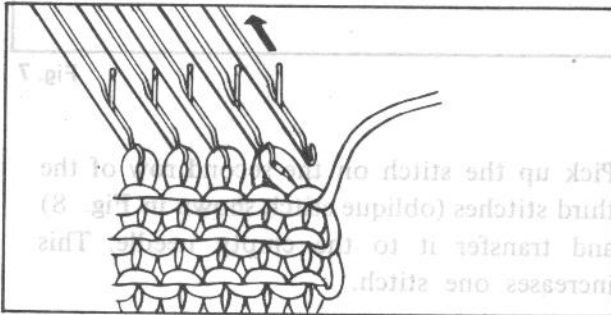

Fig. 13

Method 2

Hook the transfer tool on the third needle from the end and pull toward you until the stitch falls behind the latch.

Push the needle back until the stitch is transferred to the transfer tool.

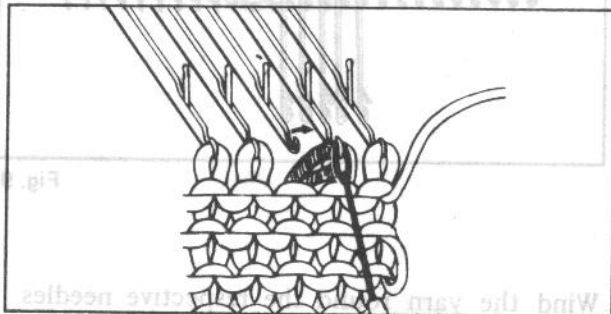

Fig. 15

Hook these two stitches onto the third needle from the end.

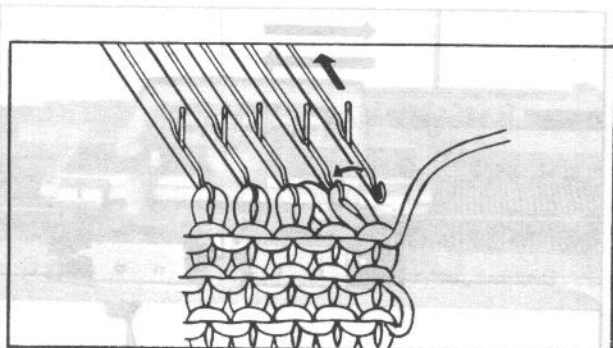

Fig. 17

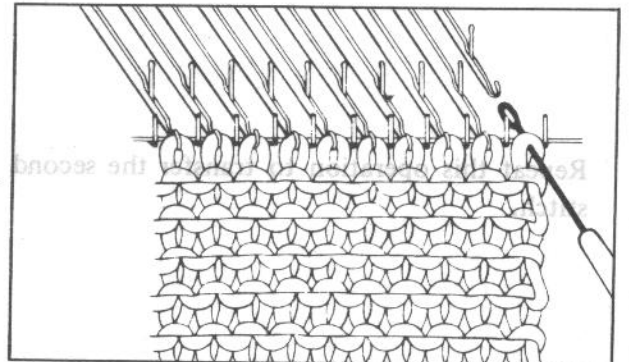

Fig. 12

Hook this stitch onto the next inside needle. Push empty needle to A position. These will knit into one stitch as the carriage is moved across the row.

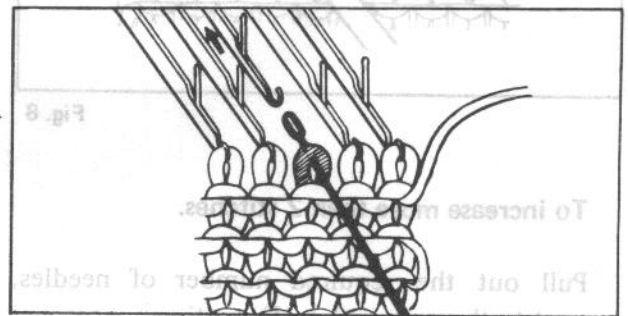

Fig. 14

Hook this stitch onto the second needle from the end.

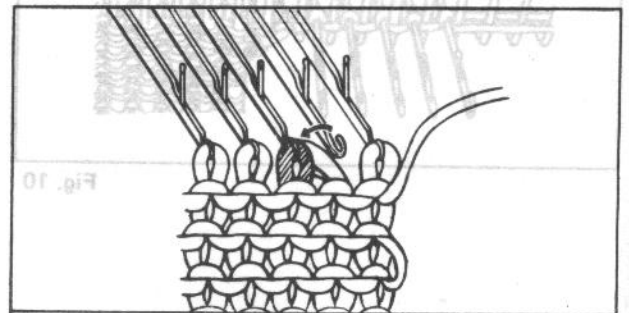

Fig. 16

Hook the end stitch onto the second needle from the end. Push empty needle to A position.

To decrease several stitches

Method 1. (Casting off)

1. Hook the transfer tool on the second needle from the end, pull toward you until the stitch falls behind the latch.
2. Push the needle back until the stitch is transferred to the transfer tool.

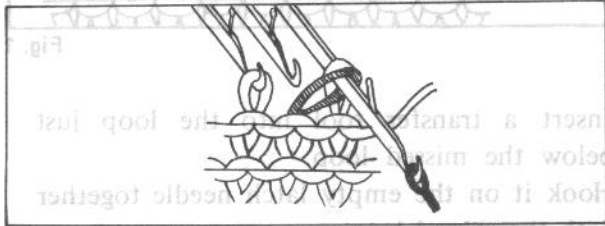

Fig. 19

4. Wind yarn around hook of this needle loosely, then by hand push the needle back to B position, thus making one stitch.

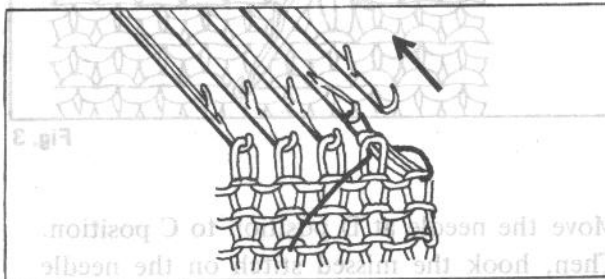

Fig. 22

Method 2

Thread another yarn into the seaming needle and pass the needle through stitches as shown in Fig. 23.

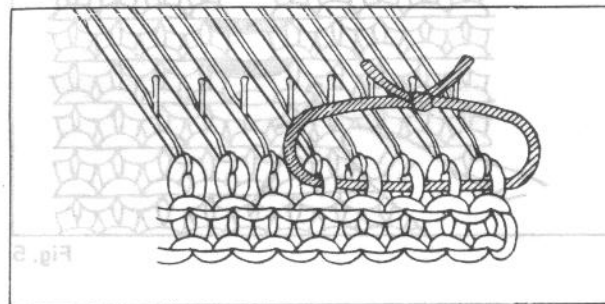

Fig. 24

Remove stitches from the needles and push the empty needles to A position.

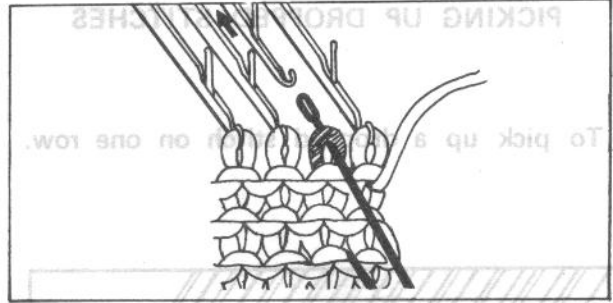

Fig. 18

3. Hook this stitch onto the end needle and pull this needle through to E position.

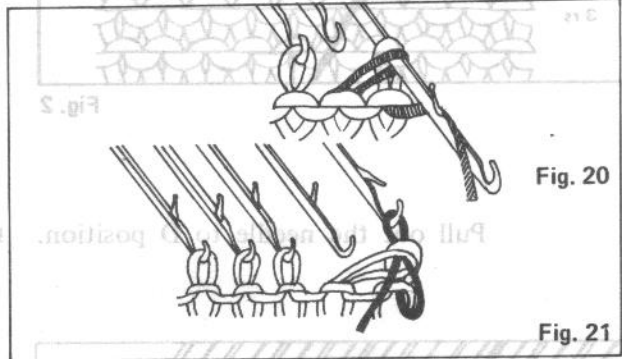

Fig. 20

5. Transfer this stitch to the next inside needle, and push the empty needle to A position. Repeat above steps 4-5 as required.

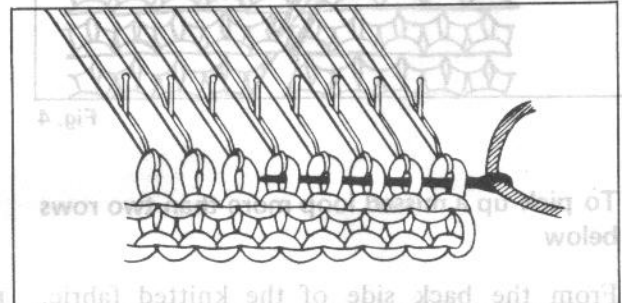

Fig. 23

- Tie both ends of the yarn passing through the stitches securely.

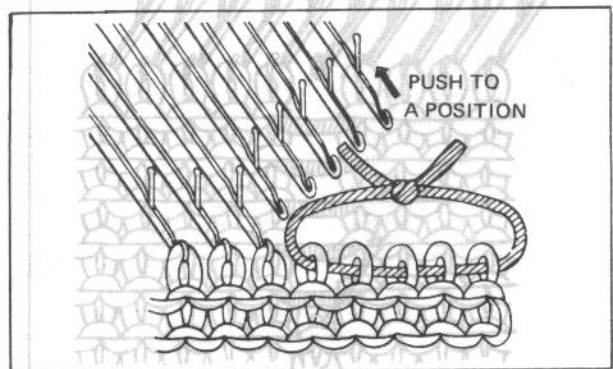

Fig. 25

PICKING UP DROPPED STITCHES

To pick up a dropped stitch on one row. ▶

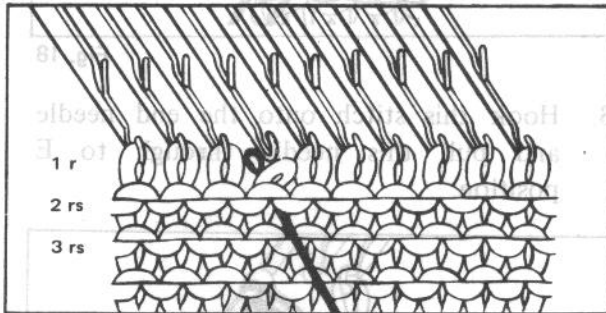

Fig. 2

Pull out the needle to D position. ▶

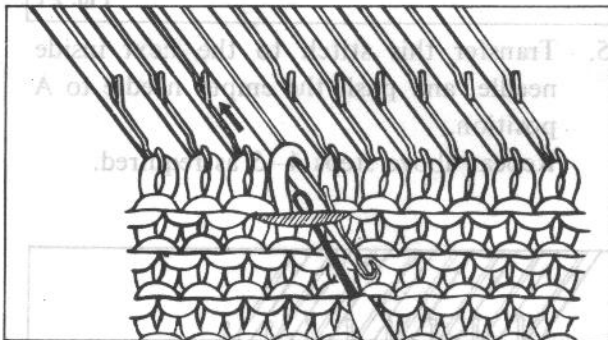

Fig. 4

To pick up a missed loop more than two rows below

From the back side of the knitted fabric, insert a latch needle tool two or three loops below the missed loop. ▶

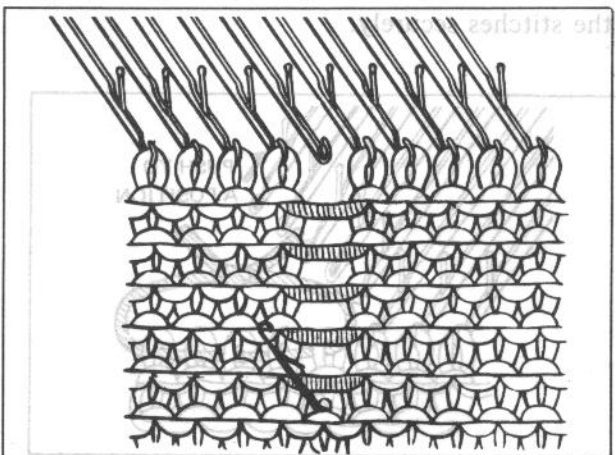

Fig. 6

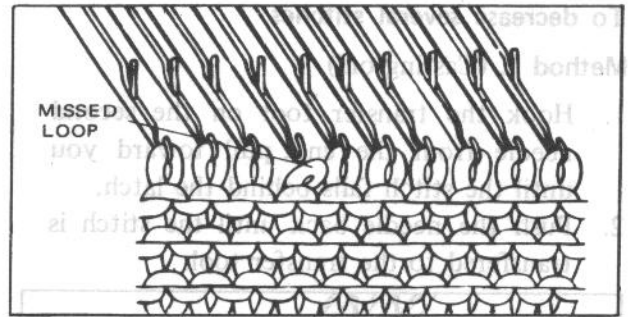

Fig. 1

▶ Insert a transfer tool into the loop just below the missed loop. Hook it on the empty latch needle together with the missed loop.

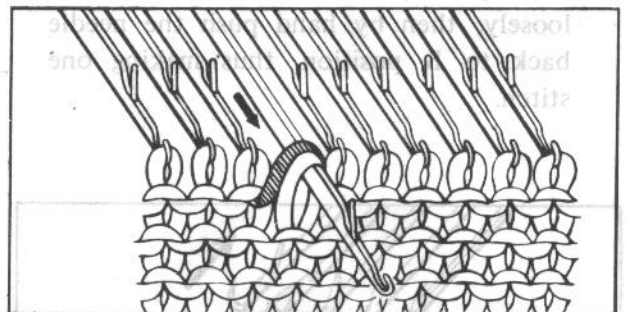

Fig. 3

▶ Move the needle at D position to C position. Then, hook the missed stitch on the needle hook and push the needle to B position to pick up the new loop.

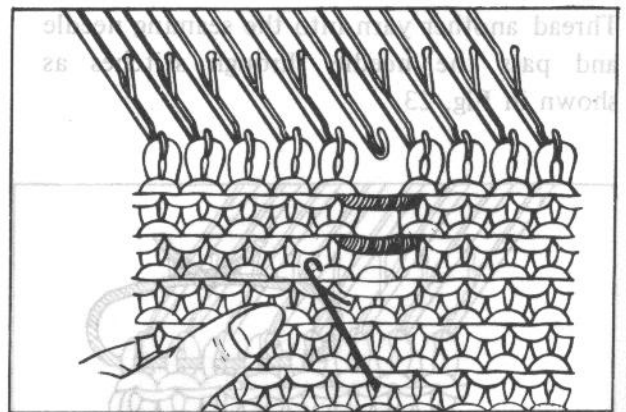

Fig. 5

▶ Remove stitches from the needles and push the empty needles to A position.

Withdraw the latch needle tool slowly and pick up the cross thread immediately above the loop in the hook of the latch needle tool making certain the latch closes. This will knit one stitch.

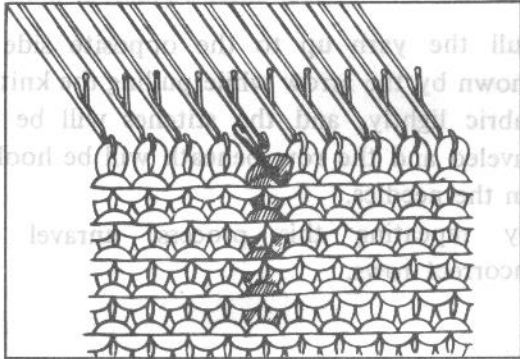

Fig. 8

Unhook the latch needle tool, and pick up the loop with a transfer tool from the front and hook it on the needle.

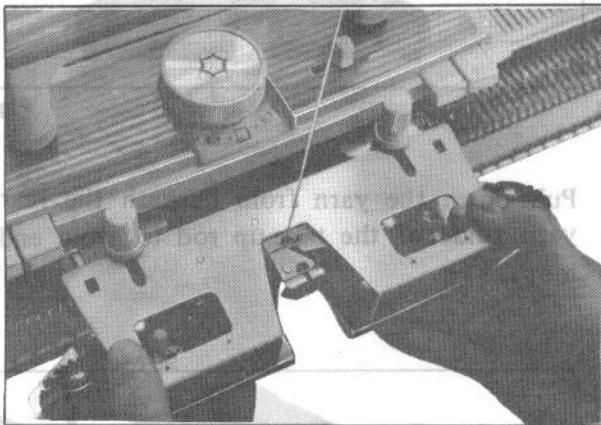

Fig. 10

Tilt back the carriage and return to beginning of row. Unravel stitches back to beginning of row.

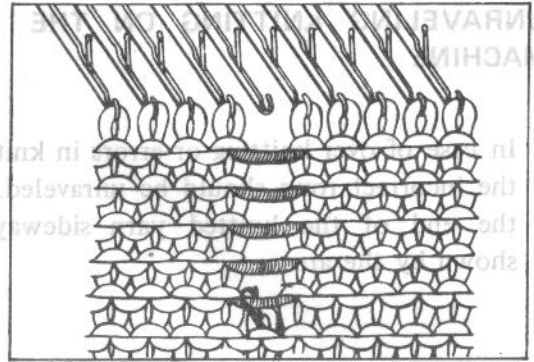

Fig. 7

Push the latch needle tool through the knitted fabric from the back again forcing the loop on the hook back over the latch and onto the latch needle tool shaft. Again withdraw the tool picking up the cross thread above it and continue until all the stitches are knitted.

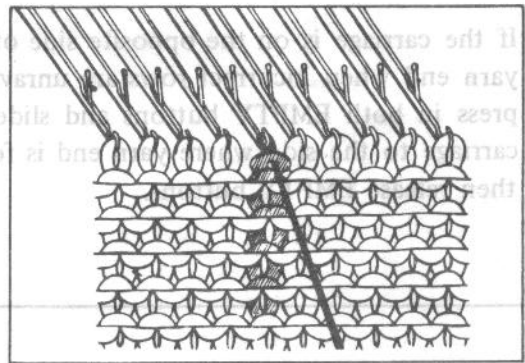

Fig. 9

DETACHING THE CARRIAGE WHILE KNITTING

When the carriage gets stuck or there is a knitting error, do not move the carriage by force, but detach the fabric presser by loosening the screw knobs and pulling up the fabric presser.



Fig. 11

UNRAVELING KNITTING ON THE MACHINE

In case of over knitting or errors in knitting, the incorrect rows should be unraveled. Pull the end of the knitted yarn sideways as shown by the arrow.

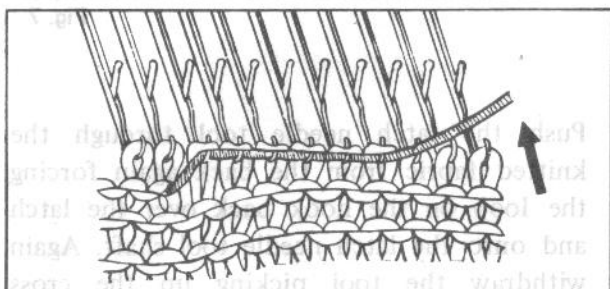

Fig. 2

If the carriage is on the opposite side of the yarn end when incorrect rows are unraveled, press in both EMPTY buttons and slide the carriage to the side where yarn end is found then release EMPTY buttons.

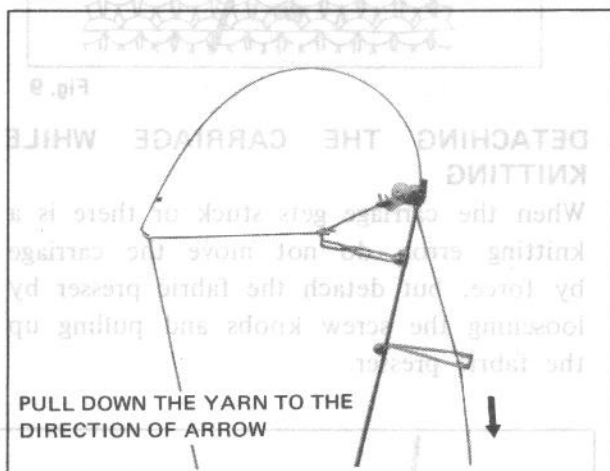

Fig. 4

Turn the row counter dials toward the direction of arrow to correspond to the number of rows unraveled (Make sure that the dials are turned in the direction of the arrow.)

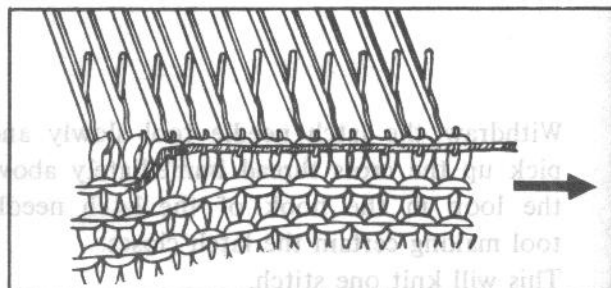

Fig. 1

Pull the yarn up to the opposite side as shown by the arrow while pulling the knitted fabric lightly, and the stitches will be unraveled and the row beneath will be hooked on the needles. By repeating this process, unravel the incorrect rows.

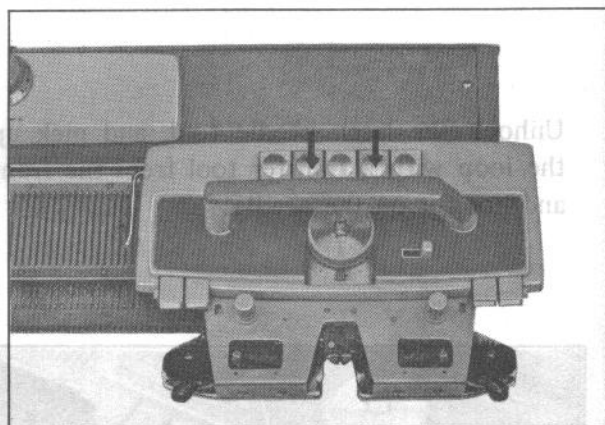

Fig. 3

Pull down the yarn from beneath the rear yarn guide of the take-up rod to avoid end loops.

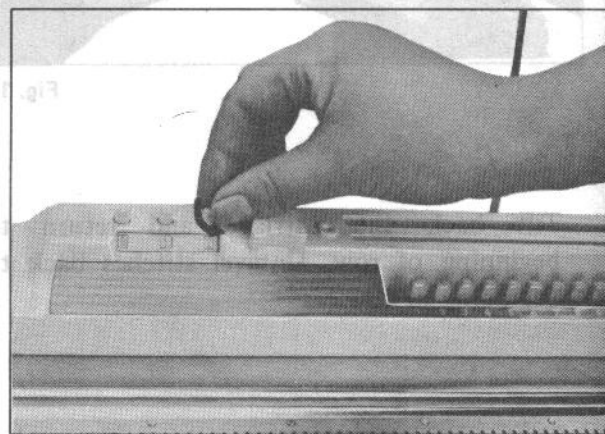

Fig. 5

SEAMING

To seam rib stitch:-

Seam through one stitch at a time row by row as shown in Fig. 6.

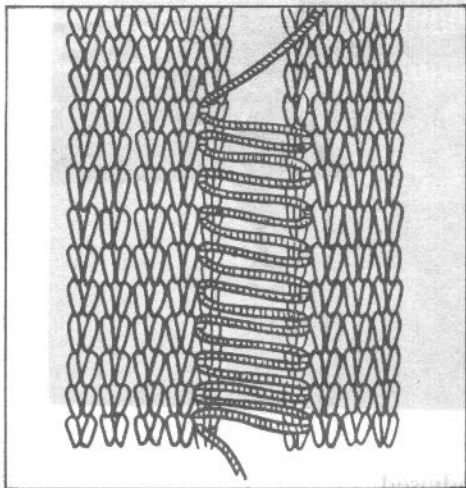

Fig. 7

While seaming never pull the seaming yarn too tight, otherwise the seaming yarn will break or the seam will pucker.

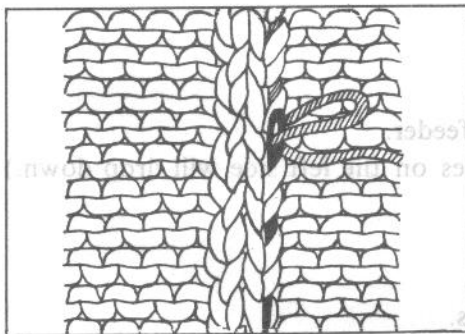

Fig. 9

TO BIND OFF THE RIB STITCHES

Turn the stitch with the yarn end toward you, and pass the seaming needle through the first and the second stitch from the end.

Pass the needle through the first and the third stitch as shown in Fig. 10.

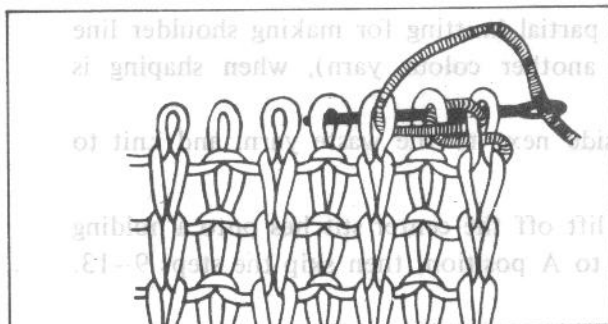

Fig. 11

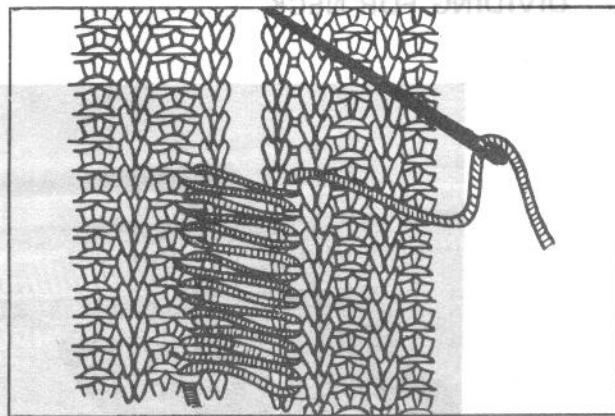

Fig. 6

◀ To seam plain stitch: —
Use the same method as above.

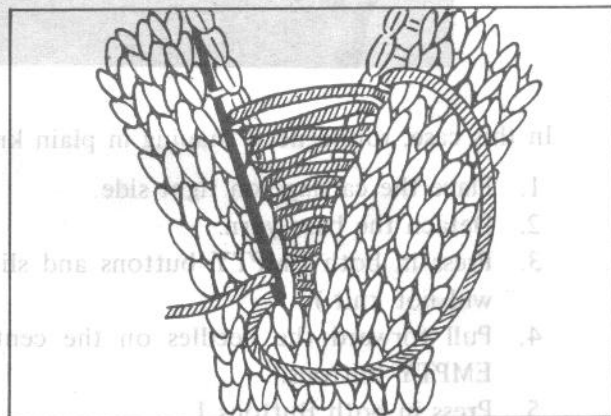

Fig. 8

◀ Weave the surplus ends into the seams.

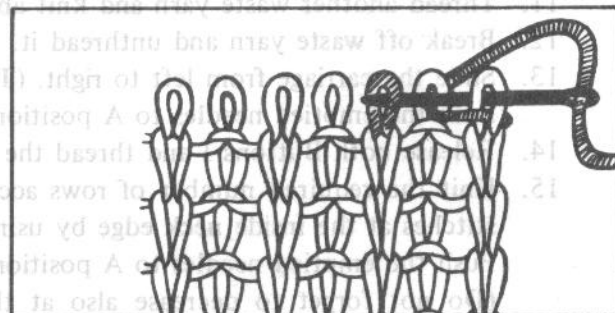
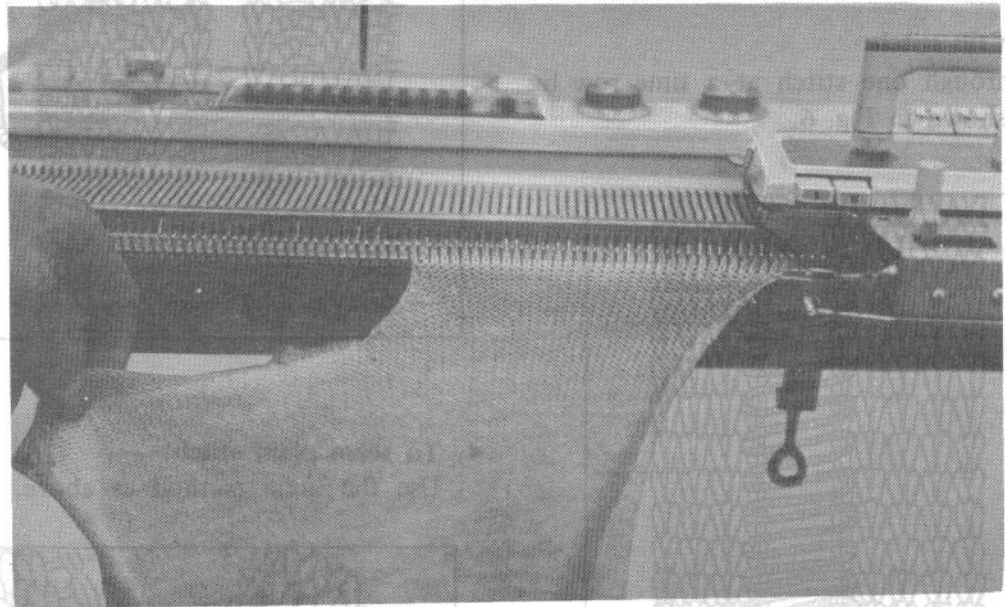

Fig. 10

◀ Then pass the needle through the second and the fourth stitch as shown in Fig. 11. Repeat this operation to bind off the rib stitch.

DIVIDING FOR NECK



In this case, round neck shaping in plain knitting is advised.

1. Place the carriage on right side.
2. Detach the base yarn.
3. Press in both EMPTY buttons and slide the carriage from right to left. (All needles will not knit.)
4. Pull forward the needles on the center and right side to E position. Release both EMPTY buttons.
5. Press in both Buttons I.
6. Thread waste yarn and knit 6 rows.
7. Break off waste yarn and unthread it from yarn feeder.
8. Slide the carriage from left to right. (The stitches on the left side will drop down.) Push the emptied needles back to A position.
9. Slide back the carriage from right to left.
10. Push the center needles to C position.
11. Thread another waste yarn and knit about 6 rows.
12. Break off waste yarn and unthread it.
13. Slide the carriage from left to right. (The center stitches will drop down.) Push the emptied needles to A position.
14. Release both Buttons I and thread the base yarn.
15. Knit the required number of rows according to your pattern instructions, decreasing stitches at the inside neck edge by using transfer tool. Push the emptied needles to A position at each step. (Do not forget to decrease also at the arm-hole edge where required if knitting a reglan styled garment.)
16. Cast off the shoulder stitches (or do the partial knitting for making shoulder line and then knit some waste stitches with another colour yarn), when shaping is completed.
17. Pick up the loops of base yarn on left side next to the waste yarn, and knit to match reversing shaping instructions.

Note: In the above step 4, you can prefer to lift off the center stitches onto a holding pin and push the emptied needles back to A position, then skip the steps 9–13.

RAGLAN SHAPING

When knitting raglan shaped garments using Fair isle, tuck or other fancy patterns, use the simple decrease of one stitch each end every second or third row.

For more distinctive forms of shaping, there are several variations one can use.

1. **ONE STITCH** (every 2nd or 3rd row)
Using triple transfer tool, transfer the outside 3 stitches inwards one position. This is the same as "knit 2, knit 2 together"

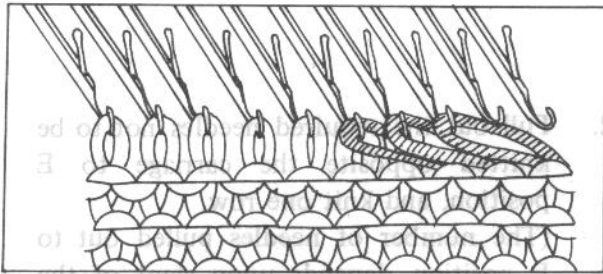

Fig. 2

- (2). Using double transfer tool, and working on first 6 needles, transfer stitches 3 and 4 onto needles 5 and 6. Transfer stitches 1 and 2 onto needles 3 and 4.

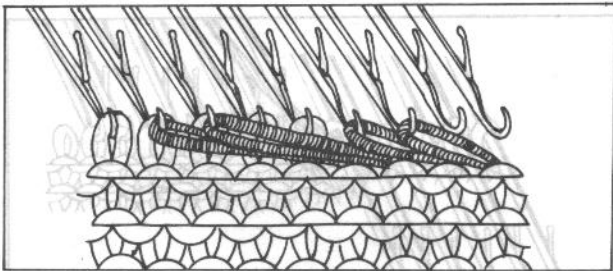

Fig. 4

3. **THREE STITCH** (every 6th, 7th or 8th row)

- (1). Using two triple transfer tools, and working on the first 9 stitches, transfer stitches 1, 2, 3, 4, 5 and 6 onto the two tools. Put stitches 1, 2 and 3 onto needles 4, 5 and 6 and stitches 4, 5 and 6 onto needles 7, 8 and 9.

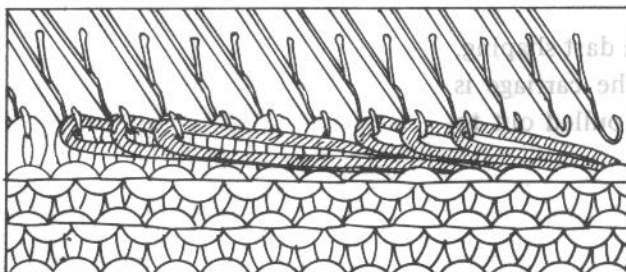

Fig. 6

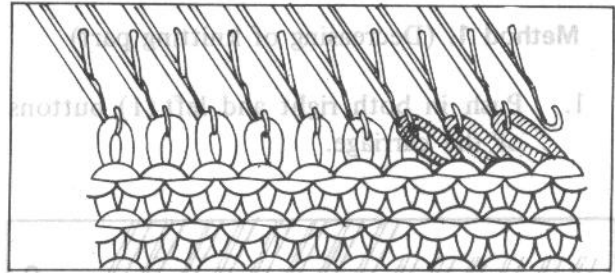

Fig. 1

2. **TWO STITCH** (every 4th or 5th row)
(1). Using triple transfer tool, transfer the outside 3 stitches inwards two positions. This is the same as "knit 1, knit 2 together twice."

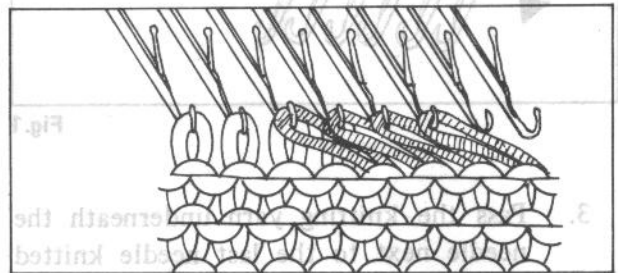

Fig. 3

- (3). Using two double transfer tools, and working on first 8 needles, transfer stitches 1, 2, 3 and 4 onto the two tools. Put stitches 1 and 2 onto needles 3 and 4, and stitches 3 and 4 onto needles 7 and 8.

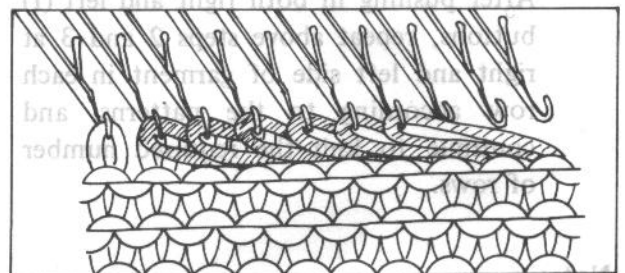

Fig. 5

- (2). Using two triple transfer tools, and working on the first 12 stitches, transfer stitches 1, 2, 3, 4, 5 and 6 onto the two transfer tools. Put stitches 1, 2 and 3 onto needles 4, 5 and 6 and stitches 4, 5 and 6 onto needles 10, 11 and 12.

Note: After transfers have been completed, remember to push empty needles back to A position before knitting the row.

When knitting the shoulder lines, sleeve tops, etc. for a garment, only part of a row is knitted.

PARTIAL KNITTING IN PLAIN STITCH

Method 1. (Decreasing of knitting part)

1. Push in both right and left (I) buttons of the carriage.

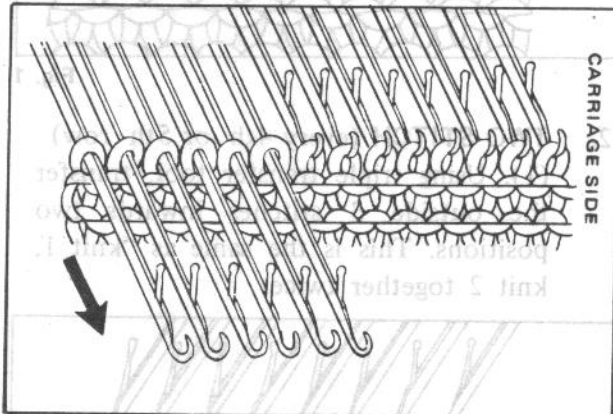

Fig.1

3. Pass the knitting yarn underneath the needle next to the last needle knitted as shown in Fig. 2, and knit one row. After repeating steps (2) – (3) and knitting required even-numbered rows, return the right and left (I) buttons and knit one row.

You have completed partial knitting.

Making darts

After pushing in both right and left (I) buttons, repeat above steps 2 and 3 at right and left side of garment in each row according to the patterns, and continue to knit the required number of rows.

Note:

When returning to plain knitting after making a dart shaping, make sure to return the (I) buttons when the carriage is positioned on the opposite side to the needles pulled out to E position.

Note: After transfers have been completed, remember to push empty needles back to A position before knitting the row.

ONE STITCH (every 2nd or 3rd row)
Using triple transfer tool, transfer the outside 3 stitches inward one position. This is the same as "knit 2, knit 2 together".

2. Pull out the required needles not to be knitted opposite the carriage to E position, and knit one row. (The number of needles pulled out to E position depends upon slant of the shoulder lines, sleeve tops, etc.)

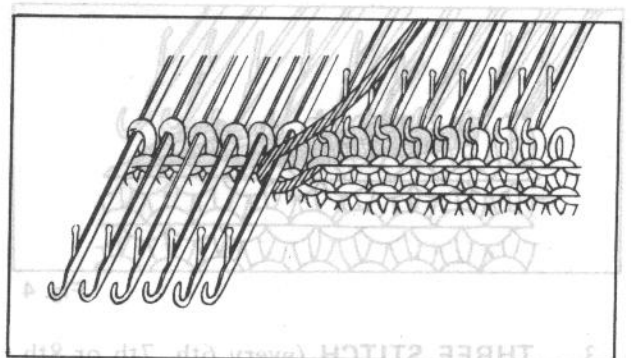

Fig.2

(1) Using two triple transfer tools, and working on the first 9 stitches, transfer stitches 1, 2, 3, 4, 5 and 6 onto the two tools. Put stitches 1, 2 and 3 onto needles 4, 5 and 6 and stitches 4, 5 and 6 onto needles 7, 8 and 9.

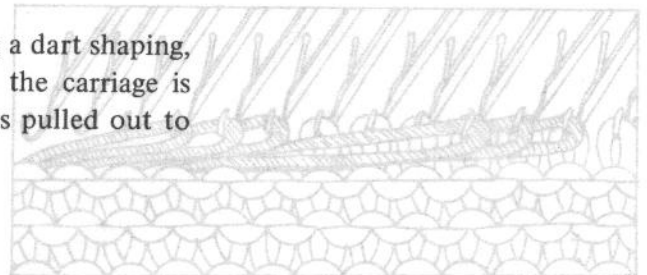

Fig. 3

Method 2. (Increasing of knitting part)

1. Push in both right and left (I) buttons of the carriage.
2. Pull out the required needles not to be knitted and opposite the carriage to E position, and knit one row.

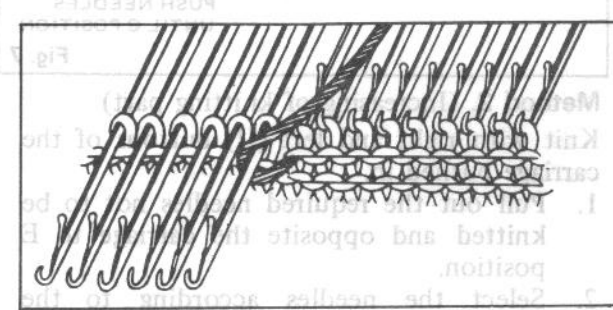
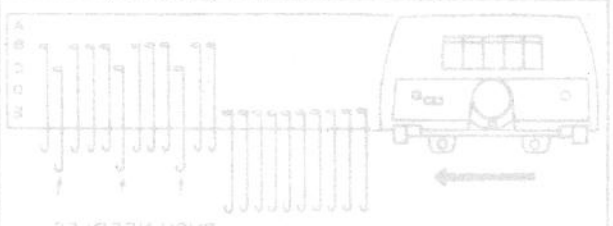

Fig. 4

4. Return a desired number of needles from E position to D position as shown Fig. 5 and knit one row. When all needles are returned to B position after repeating steps (3) — (4), return the right and left (I) buttons and knit one row.

You have completed partial knitting.

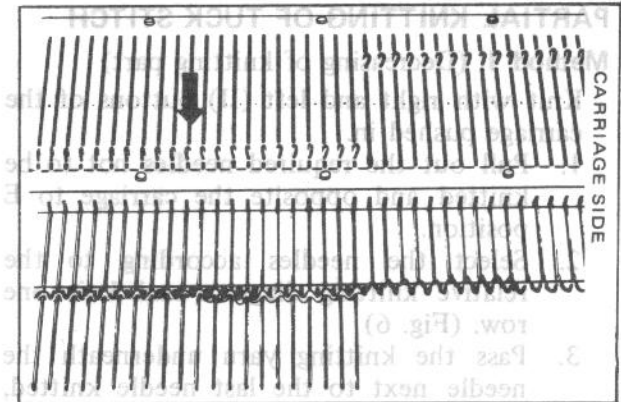
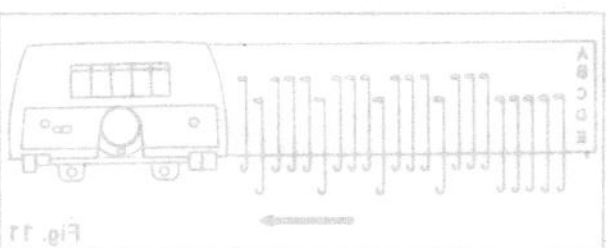
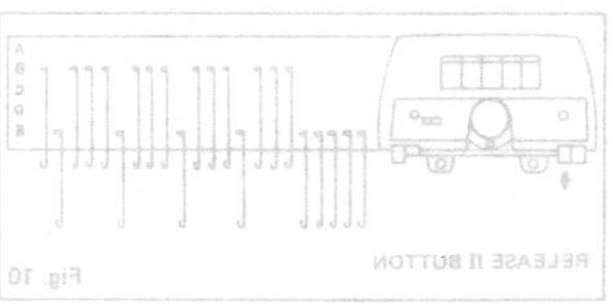

Fig. 3

3. Pass the knitting yarn underneath the needle next to the last needle knitted as shown in Fig. 4, and knit one row.

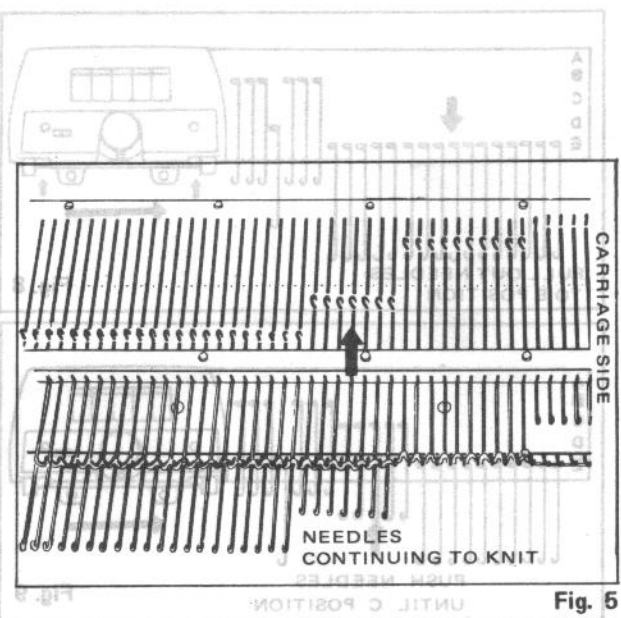

Fig. 5

PARTIAL KNITTING OF CONTINUOUS TUCK STITCH

Method 1. (Decreasing of knitting part)

- Knit with right and left (II) buttons of the carriage pushed in.
1. Pull out the required needles not to be knitted and opposite the carriage to E position.
 2. Select the needles according to the relative knitting diagram and knit one row (Fig. 10).
 3. Pass the knitting yarn underneath the needle next to the last needle knitted, and release the (II) button opposite to the sliding direction of the carriage as shown in Fig. 10. Knit one row, and the needles at E position will be pushed back to C position (Fig. 11).

PARTIAL KNITTING OF TUCK STITCH

Method 1. (Decreasing of knitting part)

Knit with right and left (II) buttons of the carriage pushed in.

1. Pull out the required needles not to be knitted and opposite the carriage to E position.
2. Select the needles according to the relative knitting diagram and knit one row. (Fig. 6)
3. Pass the knitting yarn underneath the needle next to the last needle knitted, and knit one row.
4. Pull out next group needles not to be knitted to E position, and knit one row.
5. After passing the knitting yarn underneath the needle next to the last needle knitted, push the needles which have tucked stitches at E position to C position as shown in Fig. 7, and knit one row.

Repeat the above operation (1) - (5).

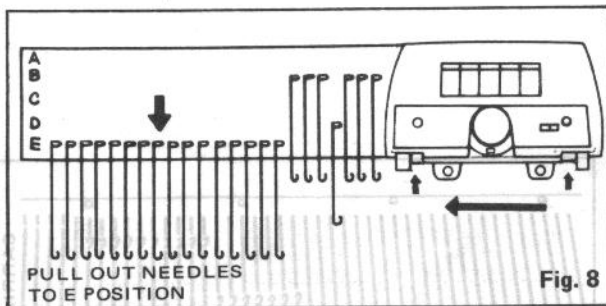

Fig. 8

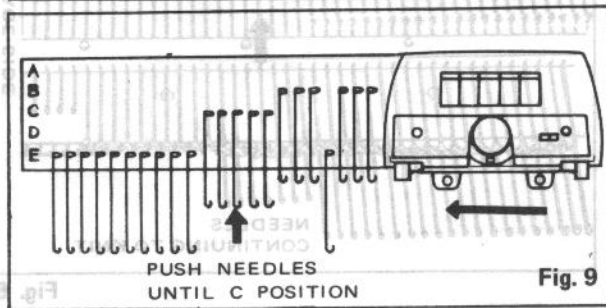

Fig. 9

PARTIAL KNITTING OF CONTINUOUS TUCK STITCH

Method 1. (Decreasing of knitting part)

Knit with right and left (II) buttons of the carriage pushed in.

1. Pull out the required needles not to be knitted and opposite the carriage to E position.
2. Select the needles according to the relative knitting diagram and knit one row. (Fig. 10)
3. Pass the knitting yarn underneath the needle next to the last needle knitted, and release the (II) button opposite to the sliding direction of the carriage as shown in Fig. 10. Knit one row, and the needles at E position will be pushed back to C position. (Fig. 11)

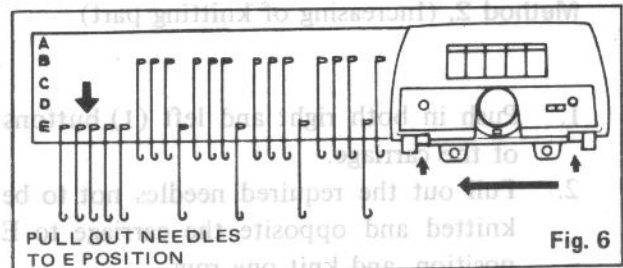

Fig. 6

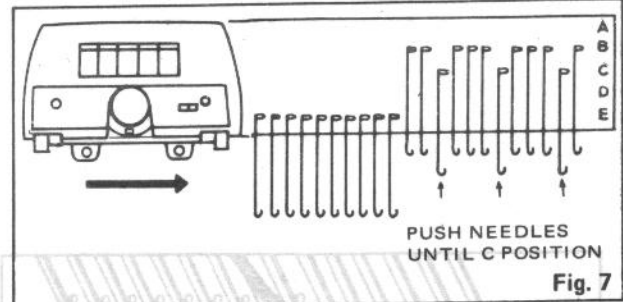

Fig. 7

Method 2. (Increasing of knitting part)

Knit with right and left (II) buttons of the carriage pushed in.

1. Pull out the required needles not to be knitted and opposite the carriage to E position.
2. Select the needles according to the relative knitting diagram, and knit one row. (Fig. 8)
3. Pass the knitting yarn underneath the needle next to the last needle knitted, and knit one row.
4. Push the needles continuing to knit to C position as shown in Fig. 9 and knit one row.
5. After passing the knitting yarn underneath the needle next to the last needle knitted, push the needles which have tucked stitches at E position to C position as shown in Fig. 7, and knit one row.
6. After pushing the needles continuing to knit to C position select the needles according to the relative knitting diagram and knit one row. (Fig. 9)

Repeat the above steps (3) - (6).

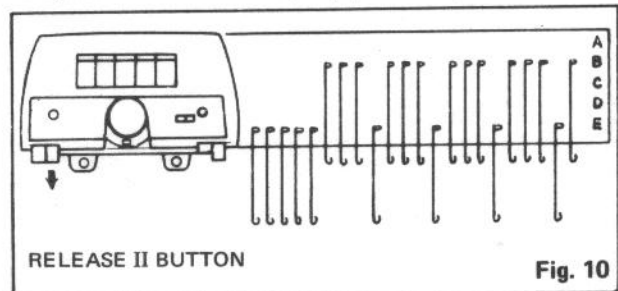

Fig. 10

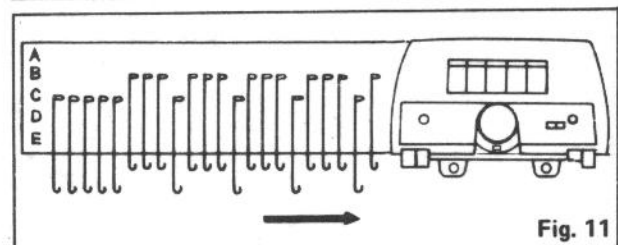

Fig. 11

4. Pull out to E position the required needles not to be knitted and the needles pushed back to C from E position as shown in Fig. 12.
 5. Push again the (II) button released in the step (3).
- Repeat the above steps (2) – (5).

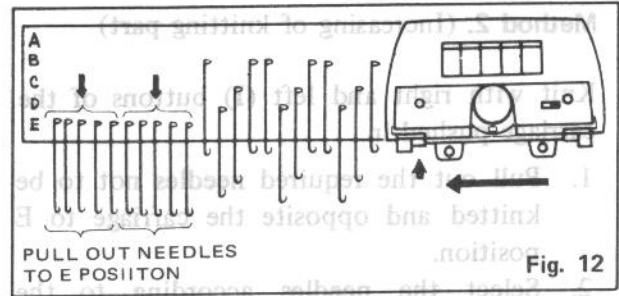

Fig. 12

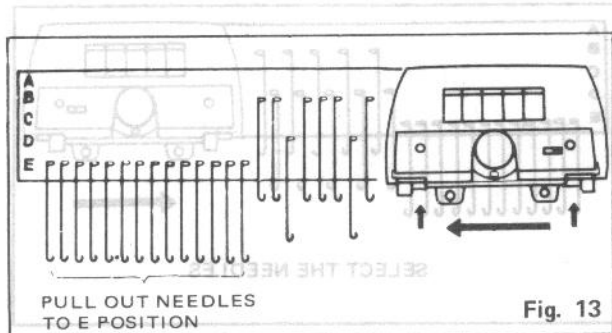

Fig. 13

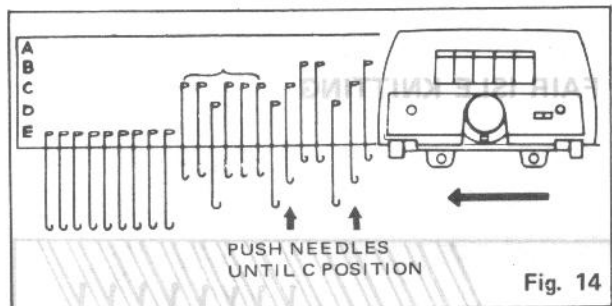

Fig. 14

PARTIAL KNITTING OF TUCK PATTERN STITCH, SLIP LOOP TUCK STITCH AND THREAD KNITTING

Method 1. (Decreasing of knitting part)

Knit with right and left (I) buttons of the carriage pushed in. (Fig. 15)

1. Pull out the required needles not to be knitted and opposite the carriage to E position.
 2. Select the needles according to the relative knitting diagram, and knit one row.
 3. Pass the knitting yarn underneath the needle next to the last needle knitted.
 4. Repeat step (2).
- Repeat the above steps (1) – (4).

Method 2. (Increasing of knitting part)

Knit with right and left (II) buttons of the carriage pushed in.

1. Pull out the required needles not to be knitted and opposite the carriage to E position.
2. Select the needles according to the relative knitting diagram, and knit one row. (Fig. 13)
3. Pass the knitting yarn underneath the needle next to the last needle knitted, and knit one row.
4. After pushing the needles continuing to knit and the needles which have tucked stitches to C position, select the needles according to the relative knitting diagram and knit one row. (Fig. 14)

Repeat the above steps (3) – (4).

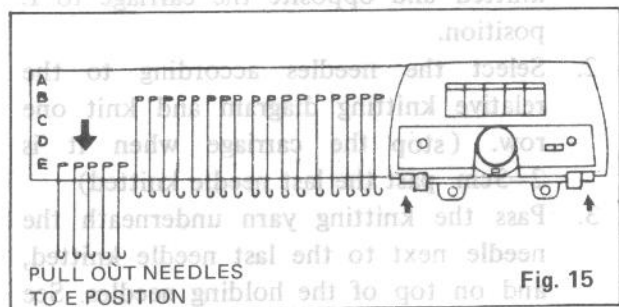

Fig. 15

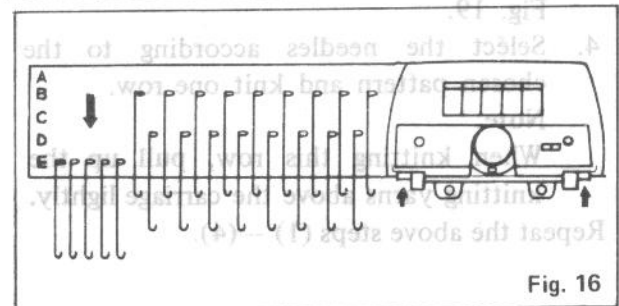

Fig. 16

Method 2. (Increasing of knitting part)

Knit with right and left (I) buttons of the carriage pushed in.

1. Pull out the required needles not to be knitted and opposite the carriage to E position.
2. Select the needles according to the relative knitting diagram, and knit one row.
3. Pass the knitting yarn underneath the needle next to the last needle knitted.
4. Repeat step (2).
5. Push the needles continuing to knit to B position. (Fig. 17)
6. Select the needles according to the relative knitting diagram and knit one row. (Fig. 18)

Repeat the above steps (3) – (6).

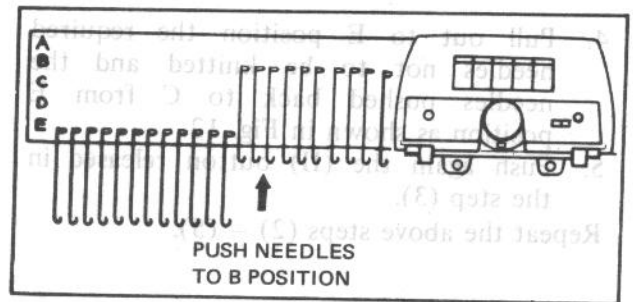

Fig. 17

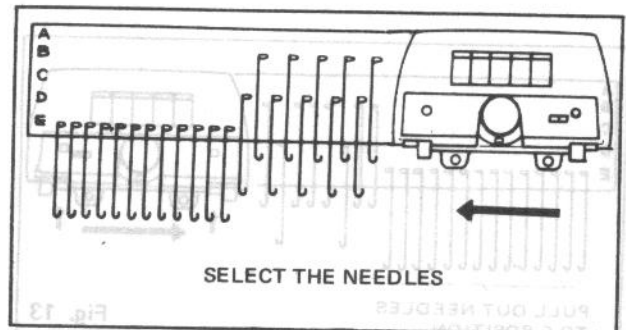

Fig. 18

PARTIAL KNITTING OF FAIR ISLE KNITTING

Method 1. (Decreasing of knitting part)

Knit with right and left (I) buttons of the carriage pushed in.

1. Pull out the required needles not to be knitted and opposite the carriage to E position.
2. Select the needles according to the relative knitting diagram and knit one row. (stop the carriage when it is 2–3cm. past the last needle knitted)
3. Pass the knitting yarn underneath the needle next to the last needle knitted, and on top of the holding needles. See Fig. 19.
4. Select the needles according to the chosen pattern and knit one row.

Note:

When knitting this row, pull up the knitting yarns above the carriage lightly.

Repeat the above steps (1) – (4).

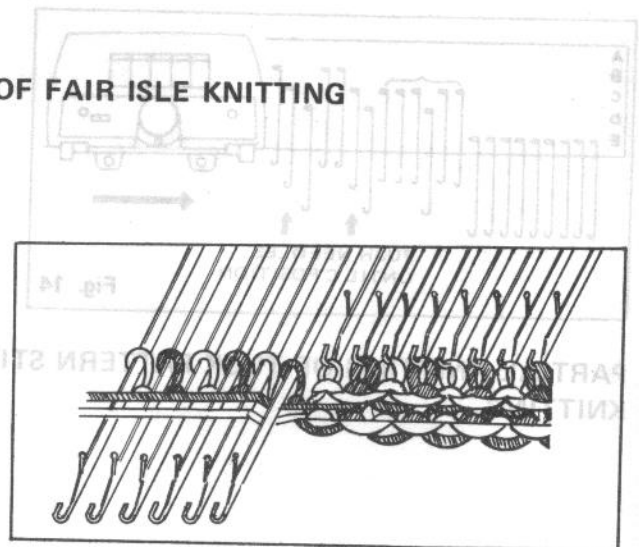

Fig. 19

Method 2 (Increasing of knitting part)

Knit with right and left (I) buttons of the carriage pushed in.

Knit in the same way as the steps (1) – (4) of the Method 1.

5. Push the needles continuing to knit to C position.
 6. Select the needles according to the chosen pattern and knit one row.
- Repeat above steps (3) – (6).

MANUAL NEEDLE SELECTION

To make your own patterns, use the Manual Needle Selection by operating the pattern selector buttons. (In this case the punch cards cannot be used.)

Move the needles from A position to B position.

Set the change lever at MANUAL position.

Set the zigzag dial at 1.

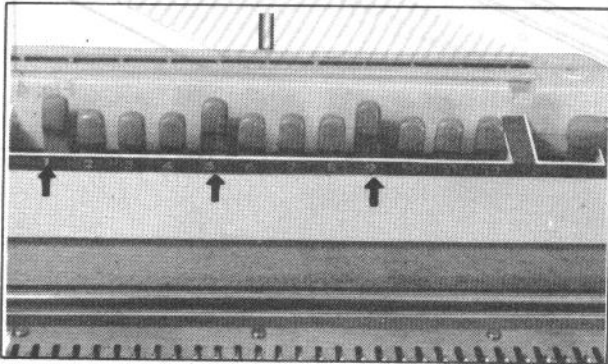

Fig. 2

Turn the needle selector lever as far as it will go and return it to the original position completely.

Every 4th needle at B position will move to D position.

This needle selection will repeat each time the needle selector lever is turned.

Knit one row after each row of knitting to next number after each row of knitting. The needle position of the machine will then be as shown in Fig. 2.

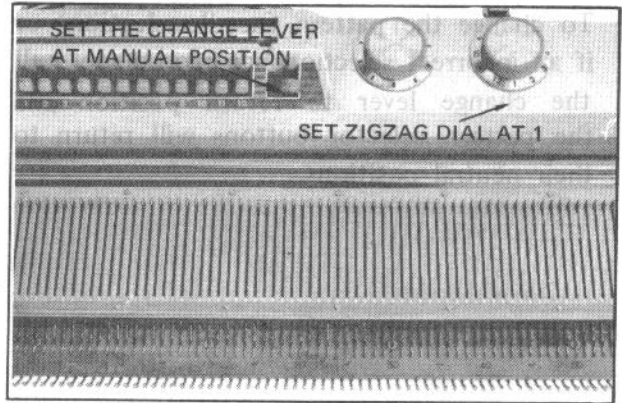

Fig. 1

Set the pattern selector buttons according to the needles required to be selected.

Example: 1 ; 3 Needle Selection.

BUTTONS SELECTOR LATTERS	1	2	3	4	5	6	7	8	9	10	11	12
1												
2												
3												
4												
5												
6												
7												
8												
9												
10												
11												
12												

Fig. 3

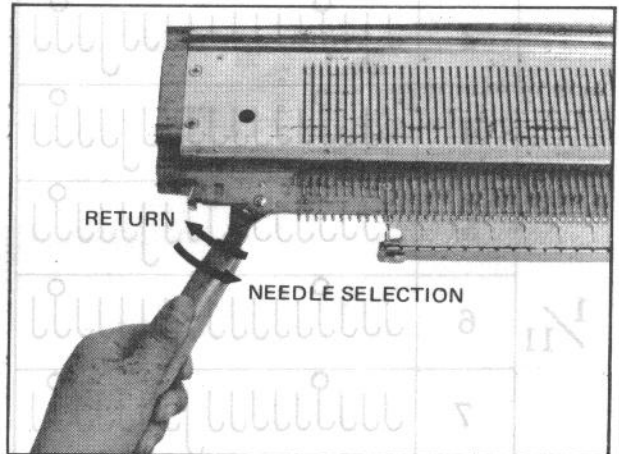

Fig. 3

To change the pattern (needle-selection) or if an incorrect selection has been made, pull the change lever to return position and the pattern selector buttons will return to their neutral positions.

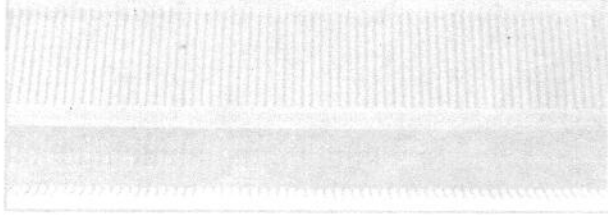

Fig. 1

MANUAL NEEDLE SELECTION

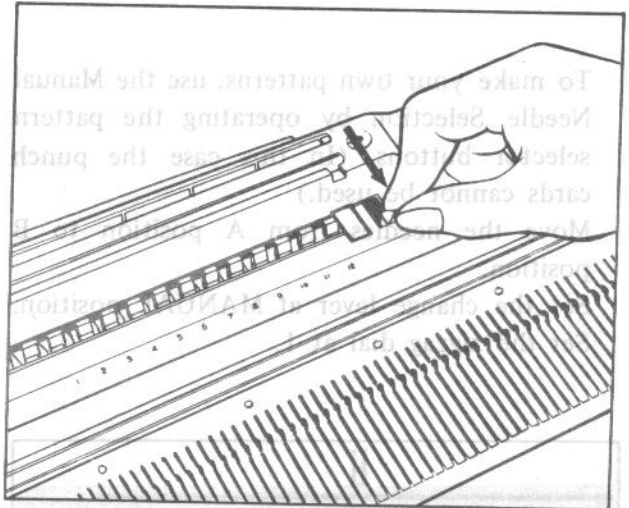

Fig. 4

POSITION OF SELECTED NEEDLES

PATTERN SELECTOR BUTTONS	ZIGZAG DIAL	NEEDLE POSITION	SET PIN
	1		
	2		
	3		
	4		
	5		
1/11	6		
	7		
	8		
	9		
	10		
	11		
	12		

Fig. 3

Fig. 5

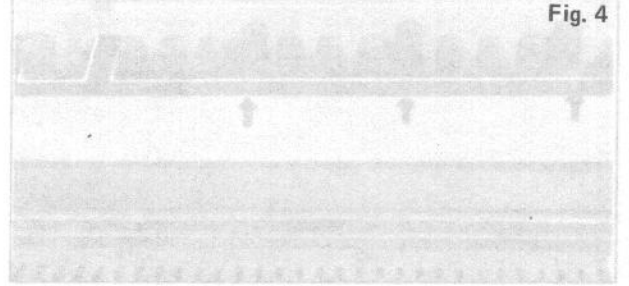

Fig. 2

USE OF ZIG ZAG DIAL

The pattern can be moved one stitch to the left by using the zigzag dial.

Ex:

Push pattern selector button NO. 1. Turn zigzag dial at 1. Knit one row, then turn zigzag dial to 2. Knit one row. Continue turning Zigzag dial to next number after each row of knitting. The needle position of the machine will then be as shown in Fig. 5.

HOW TO KNIT THE PATTERN

Various kinds of pattern knitting are achieved by using needle selector buttons according to the following knitting diagram.

GAUGING

Gauge in knitting is number of stitches and number of rows per 2 inches of fabric when knitted by proper adjustment of stitch tension dial.

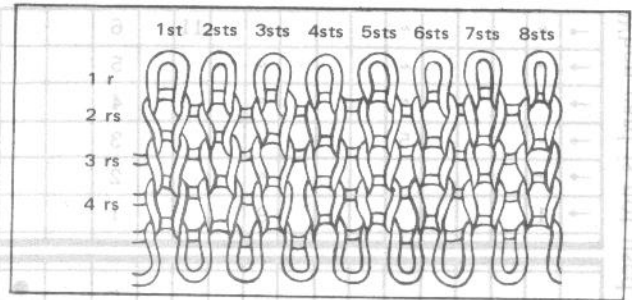

Fig. 1

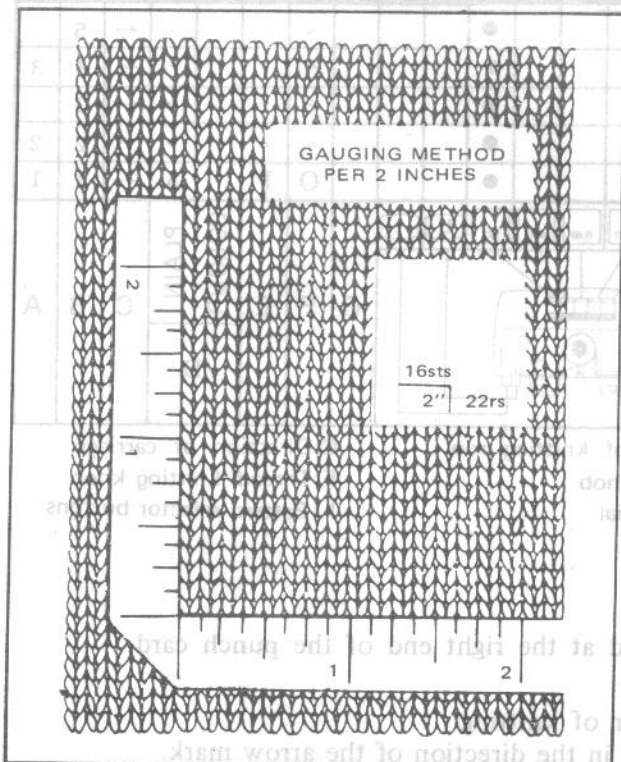

Fig. 2

By using the same yarn with which you are going to knit, make a sample piece of about 40 stitches and 40 rows.

Put the sample on a flat surface and count the rows and stitches.

In doing this, be careful not to stretch it or wrinkle it.

With tape measure determine the number of stitches and rows to two inches of knitting.

Use this guide to calculate the number of stitches and rows over the knitted garment as shown in EXAMPLE and Fig. 3.

DRAFTING

Make a pattern of the piece you are going to knit. (This differs according to the design of the knitting.)

Take measurements and write them on the pattern. (length, bust, shoulder length, sleeve length etc.)

(Refer to gauging method)

Example

Gauge: 16 Stitches,
22 rows (per 2 inches)

Length: 22 inches
22 x 11 (per inch) = 242 rows

Bust: 37 inches
37 x 8 (per inch) = 296 stitches

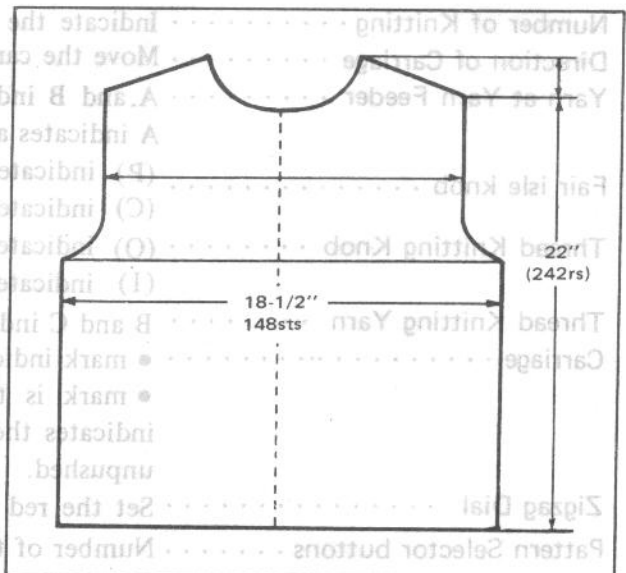

Fig. 3

Note:

Length and sleeve length are calculated in rows. Bust and shoulder width are calculated in stitches.

HOW TO KNIT THE PATTERN KNITTING

Various kinds of pattern knitting are achieved by using needle selector buttons according to the following knitting diagram.

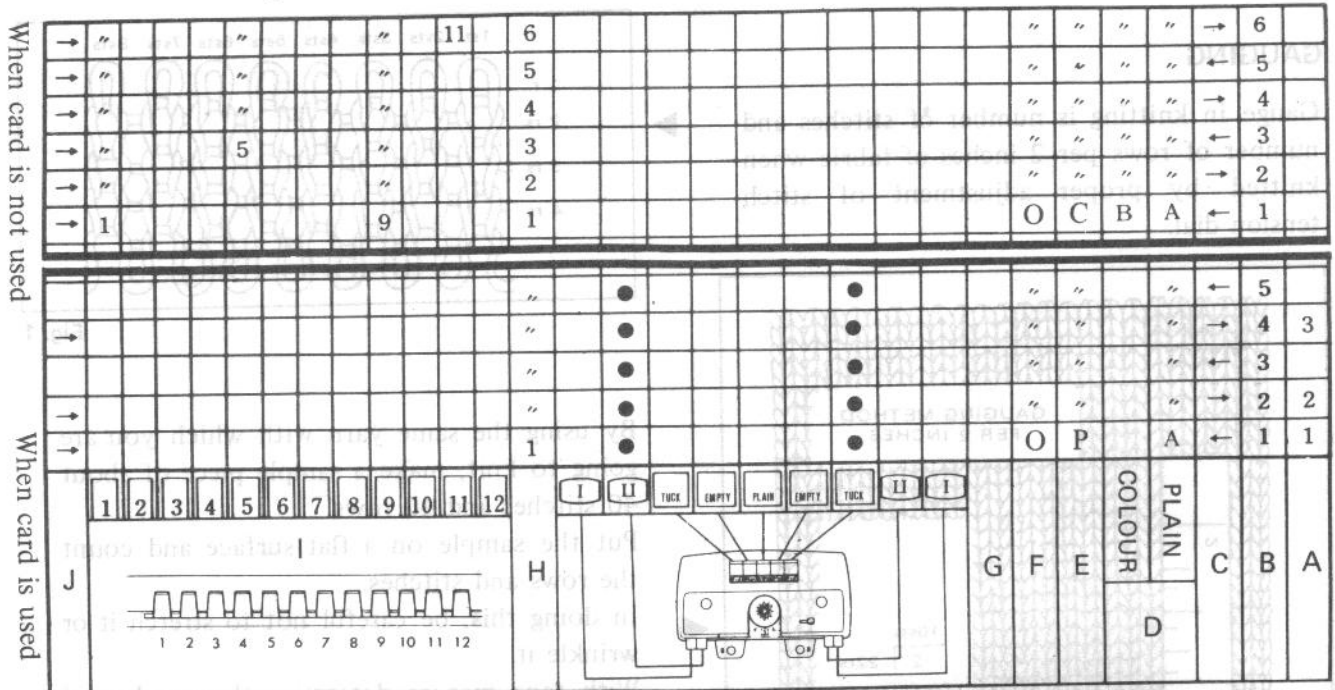

- A: Row number of punch card pattern
- B: Number of knitting row
- C: Direction of carriage
- D: Yarn at yarn feeder
- E: Fair isle knob
- F: Thread knitting knob
- G: Thread knitting yarn
- H: Zigzag dial
- I: Pattern selector buttons
- J: Needle selector lever

Row Number of Numbers indicated at the right end of the punch card.
Punch Card Pattern

- Number of Knitting Indicate the order of knitting.
- Direction of Carriage Move the carriage in the direction of the arrow mark.
- Yarn at Yarn Feeder A and B indicate yarn at yarn feeder.
A indicates a base yarn and B indicates colour yarn.
- Fair isle knob (P) indicates to set the knob at PLAIN and
(C) indicates to set the knob at COLOUR.
- Thread Knitting Knob (O) indicates to set the knob at ● black mark and
(I) indicates to set the knob at ● red mark.
- Thread Knitting Yarn B and C indicate the kind of thread knitting yarn.
- Carriage ● mark indicates setting of each button.
● mark is the state of button pushed in. The blank column indicates the state of button returned to an original position or unpushed.
- Zigzag Dial Set the red index □ at the desired figure.
- Pattern Selector buttons Number of the pattern selector button indicates the state that the button is set.
The blank column indicates the state of the button returned to an original position. When the punch card is used these buttons should never be operated.
- Needle Selector Lever Arrow mark indicates turning of the needle selector lever. The blank column indicates knitting done with the needle selector lever returned.

FAIR ISLE KNITTING (TWO COLOUR KNITTING)

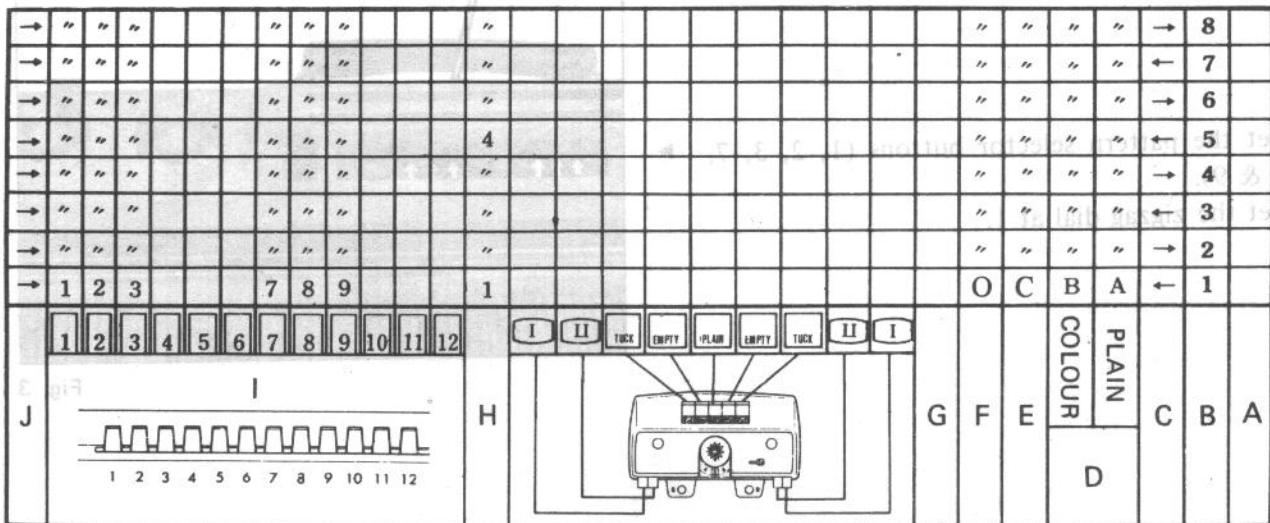

A: Row number of punch card pattern B: Number of knitting row C: Direction of carriage
 D: Yarn at yarn feeder E: Fair isle knob F: Thread knitting knob
 G: Thread knitting yarn H: Zigzag dial I: Pattern selector buttons
 J: Needle selector lever

Example by manual
 needle selecting

Yarn Used:

- A · · 3 Ply Yarn (Plain Yarn Feeder)
- B · · 3 Ply Yarn (Colour Yarn Feeder)

Stitch Adjustor Dial: 5.

* Use the Cast-on Comb.

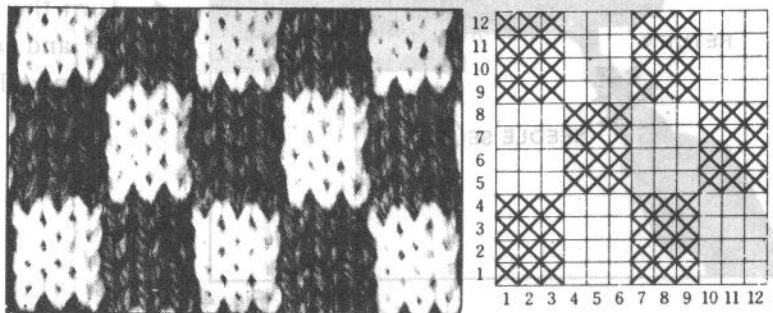

HOW TO KNIT.

Set the Fair isle knob at COLOUR position.

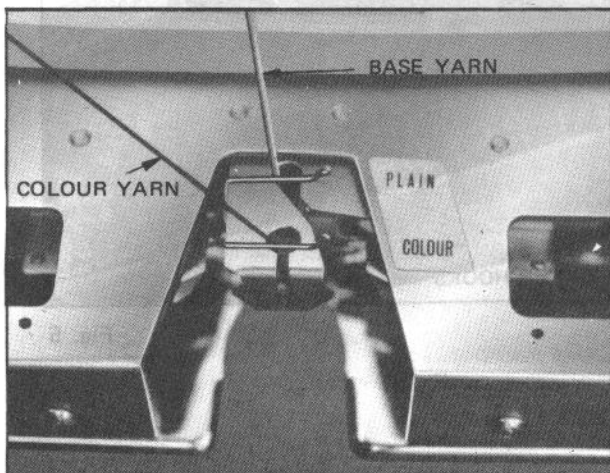

Fig. 2

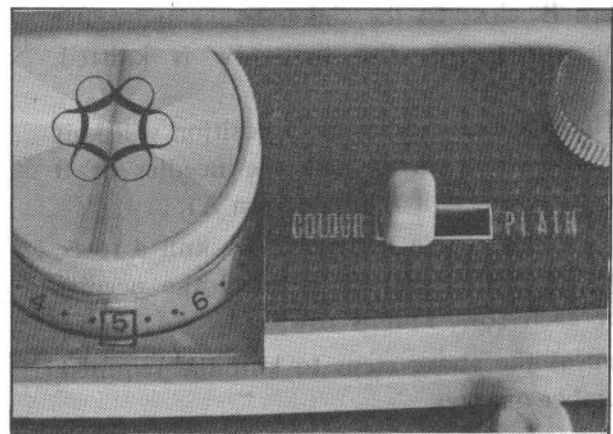

Fig. 1

- ◀ Pass the colour yarn B through the other take-up spring.
- Pass the colour yarn B through the colour yarn feeder.

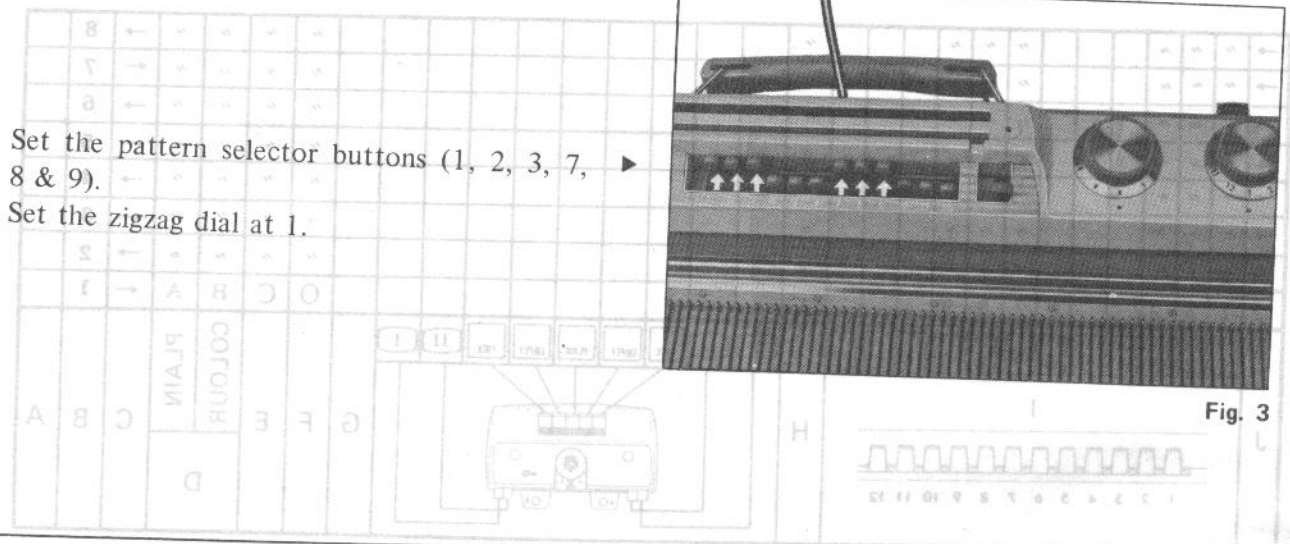

Fig. 3

Set the pattern selector buttons (1, 2, 3, 7, 8 & 9).
Set the zigzag dial at 1.

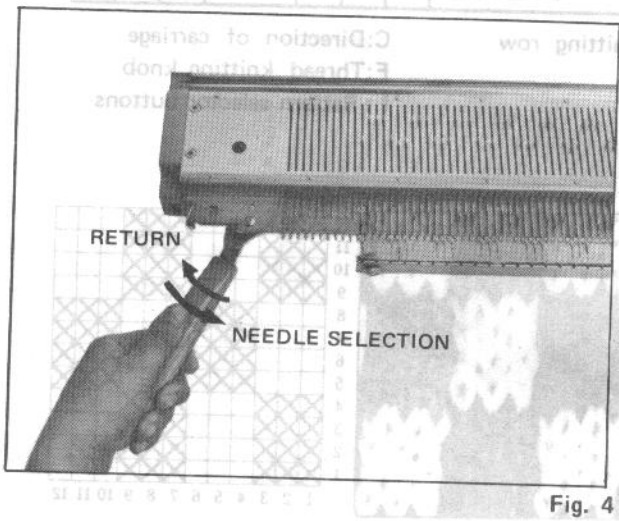

Fig. 4

Turn the needle selector lever as far as it will go and return it to the original position completely.

At the start of the knitting, hold the colour yarn B close to the sinker hooks and under the carriage as the first row is knitted.
(The selected needles at D position will knit the colour yarn B and the needles at B position will knit the base yarn A)
Select the needle for each row, knit 4 rows, set the zigzag dial at 4, select the needles for each row, knit 4 rows.
Repeat the above steps to knit the required number of rows.

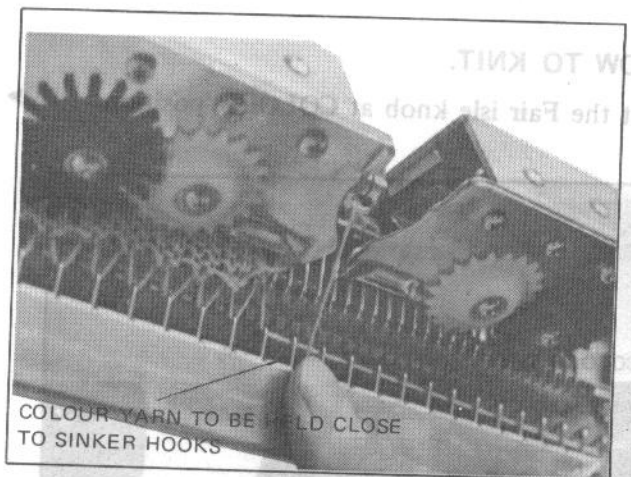
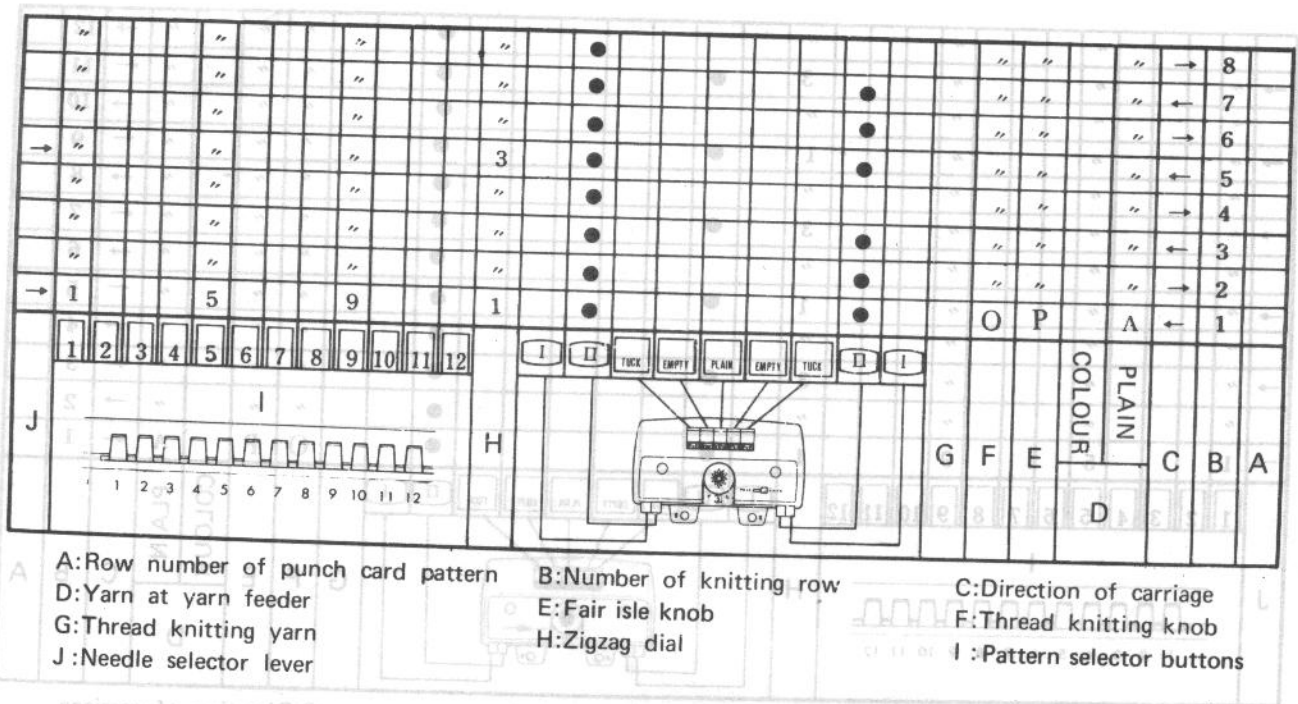

Fig. 5

COLOUR YARN TO BE HELD CLOSE TO SINKER HOOKS



C: Direction of carriage
F: Thread knitting knob
I: Pattern selector buttons

B: Number of knitting row
E: Fair isle knob
H: Zigzag dial

A: Row number of punch card pattern
D: Yarn at yarn feeder
G: Thread knitting yarn
J: Needle selector lever

Example by manual
needle selecting

* Use the Cast-on Comb.

HOW TO KNIT:

1. Press in both buttons II.
2. Set the pattern selector buttons (1, 5 & 9)
3. Set zigzag dial at 1.
4. Turn the needle selector lever as far as it will go, (The needles move to D position at interval of three needles.) The needle selector lever should be returned to the original position completely.
5. Slide the carriage and knit three rows. (The needles move to E position at interval of three needles)
6. Release button II at right side of the carriage and knit one row.
7. Set the zigzag dial at 3.
8. Turn the needle selector lever as far as it will go. Return the needle selector lever to the original position completely.
9. Press in button II at the right side of the carriage.
10. Slide the carriage and knit three rows.
11. Release button II at the right side of the carriage and knit one row.
12. Press in button II at the right side of the carriage. Repeat the steps 3 - 12 to knit the required number of rows.

Yarn Used:
3 Ply Yarn (Plain Yarn Feeder)
Stitch Adjustor Dial: 5

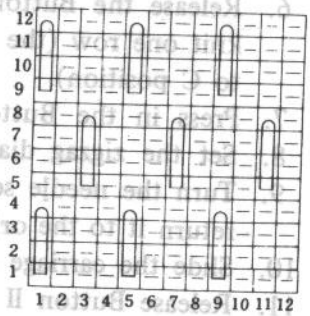
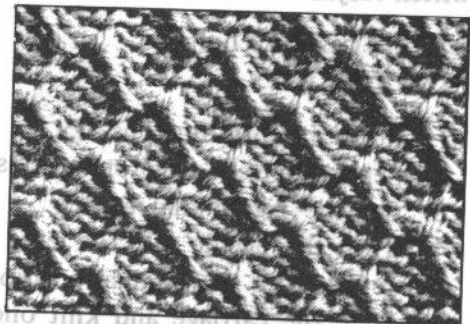

CONTINUOUS TUCK STITCH

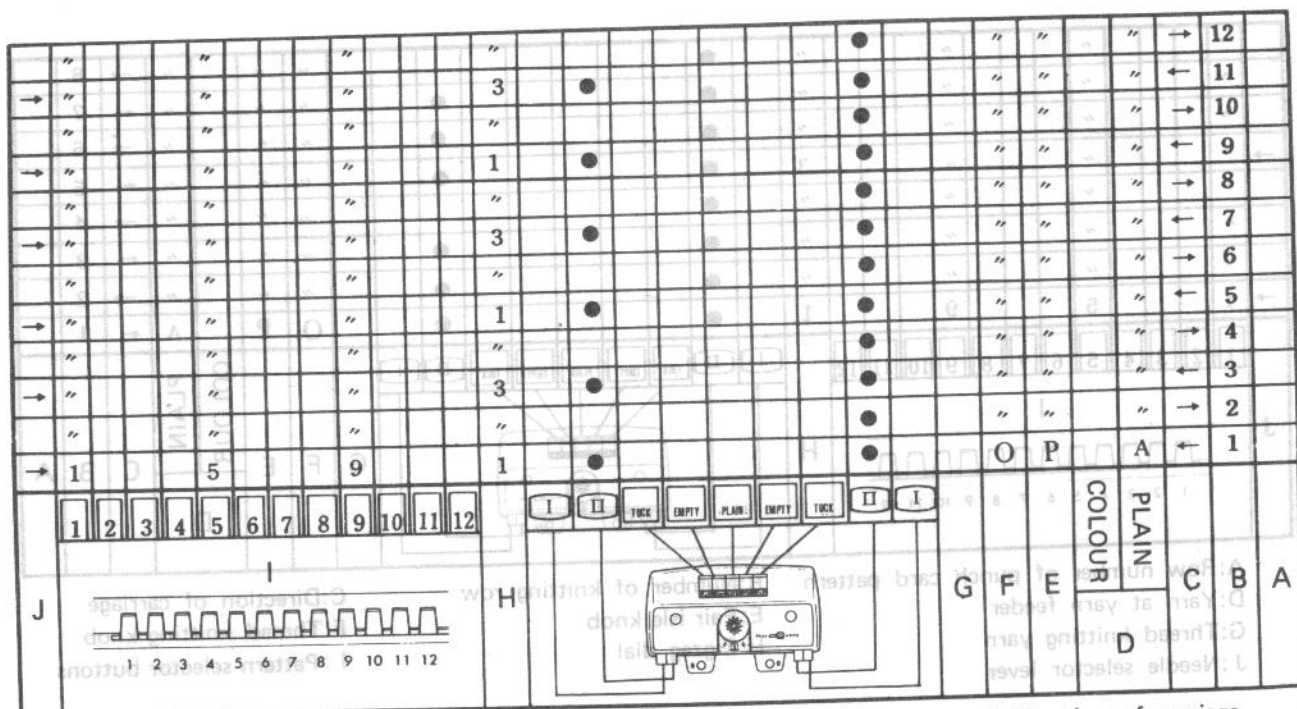

- A: Row number of punch card pattern
- B: Number of knitting row
- C: Direction of carriage
- D: Yarn at yarn feeder
- E: Fair isle knob
- F: Thread knitting knob
- G: Thread knitting yarn
- H: Zigzag dial
- I: Pattern selector buttons
- J: Needle selector lever

Example by manual needle selecting

Yarn Used: 3 Ply Yarn (Plain Yarn Feeder)
 Stitch Adjustor Dial: 5.

* Use the Cast-on Comb.

HOW TO KNIT:

1. Press in both Buttons II.
2. Set the pattern selector buttons (1, 5 & 9).
3. Set the zigzag dial at 1.
4. Turn the needle selector lever as far as it will go and return it to the original position completely.
5. Slide the carriage and knit one row.
6. Release the Button II at left side of the carriage and knit one row (the needles in the E position will shift to C position).
7. Press in the Button II at left side of the carriage.
8. Set the zigzag dial at 3.
9. Turn the needle selector lever as far as it will go and return it to the original position completely.
10. Slide the carriage and knit one row.
11. Release Button II and knit one row.
12. Press in Button II at left side of the carriage.

Repeat the steps 3 - 12 to knit the required number of rows.

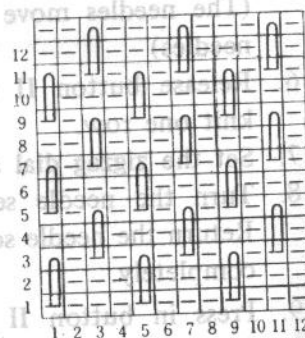
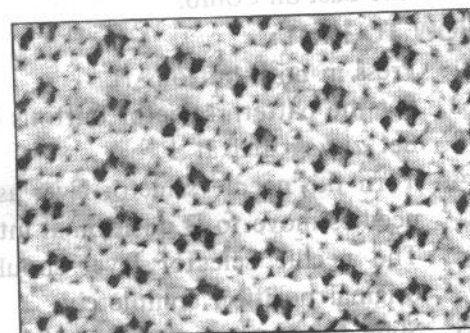

TUCK PATTERN STITCH

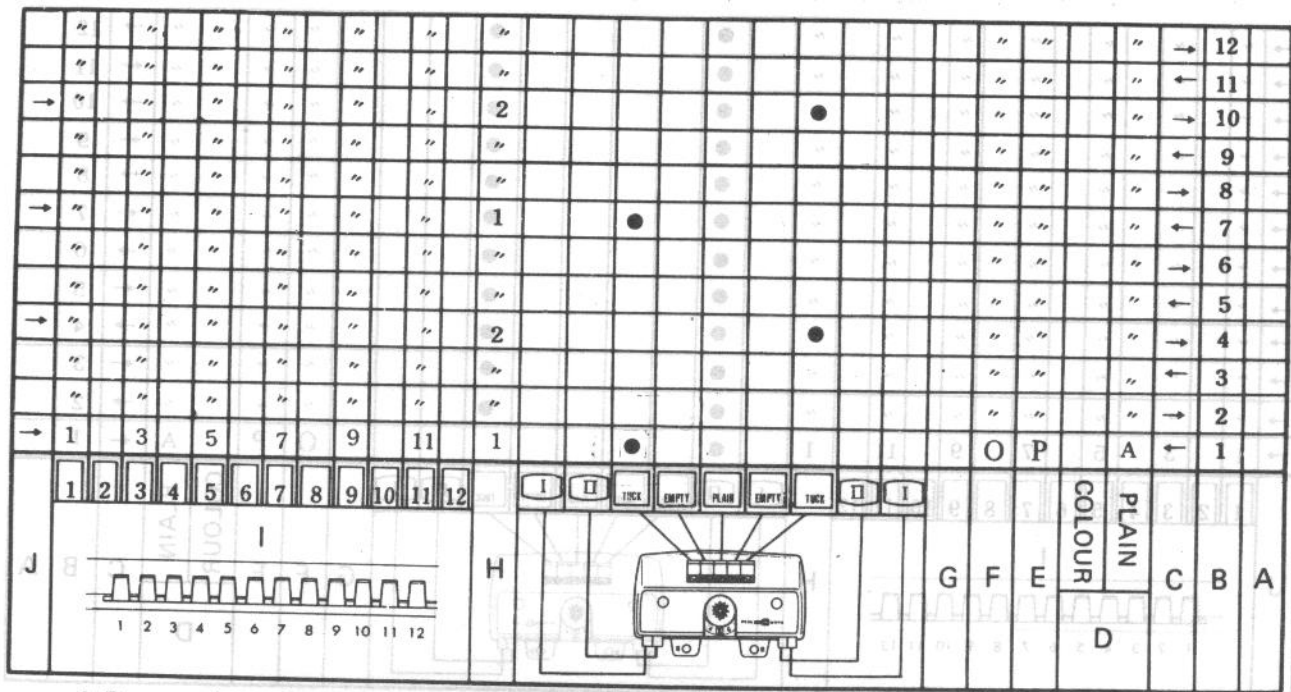

- A: Row number of punch card pattern
- B: Number of knitting row
- C: Direction of carriage
- D: Yarn at yarn feeder
- E: Fair isle knob
- F: Thread knitting knob
- G: Thread knitting yarn
- H: Zigzag dial
- I: Pattern selector buttons
- J: Needle selector lever

Example by manual needle selecting

Yarn Used: 3 Ply Yarn (Plain Yarn Feeder)

Stitch Adjuster Dial: 5

* Use the Cast-on Comb

HOW TO KNIT.

1. Set the pattern selector buttons 1, 3, 5, 7, 9, & 11.
 2. Press in Tuck Button at left side.
(Carriage is positioned at right side)
 3. Set the zigzag dial at 1.
 4. Turn the needle selector lever as far as it will go, and return it to the original position completely.
 5. Slide the carriage and knit one row. (At the time, the selected needles are under the condition for making plain knitting.)
 6. Release Tuck Button at left side by pushing Plain Button and knit two rows.
 7. Press in Tuck Button at right side.
(Carriage is positioned at left side)
 8. Set the zigzag dial at 2.
 9. Turn the needle selector lever as far as it will go, and return it to the original position completely.
 10. Slide the carriage and knit one row.
 11. Release Tuck Button at right side and knit two rows.
- Repeat the steps 7 - 8 to knit the required number of rows.

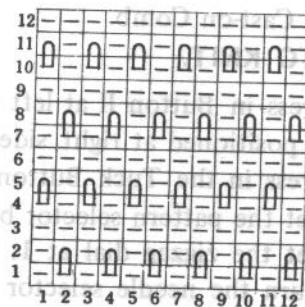
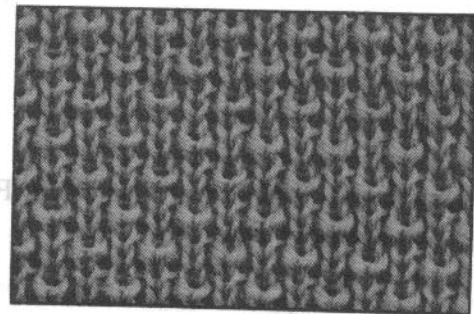

RAISED TUCK PATTERN STITCH

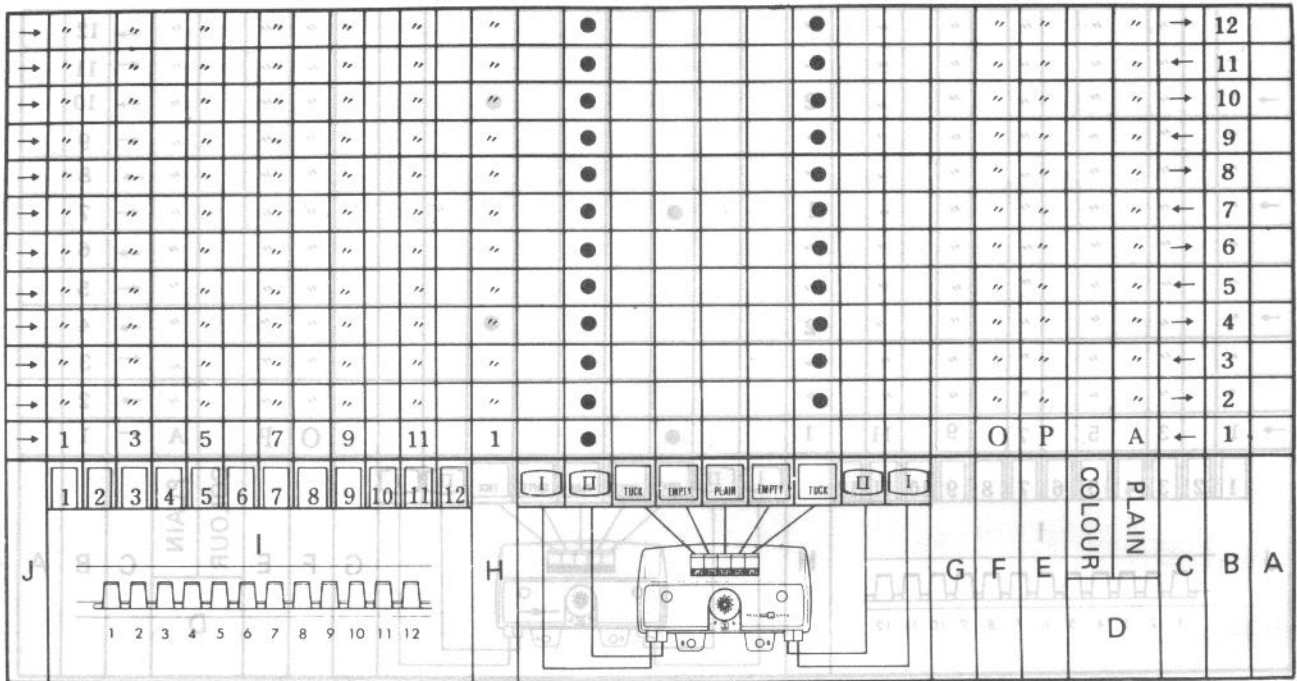

- A: Row number of punch card pattern
- B: Number of knitting row
- C: Direction of carriage
- D: Yarn at yarn feeder
- E: Fair isle knob
- F: Thread knitting knob
- G: Thread knitting yarn
- H: Zigzag dial
- I: Pattern selector buttons
- J: Needle selector lever

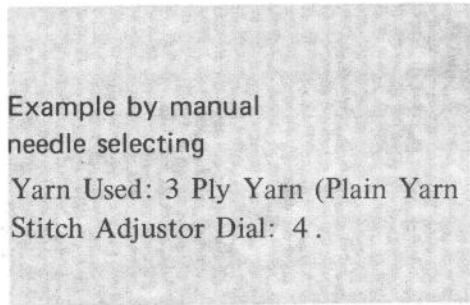

Example by manual
needle selecting

Yarn Used: 3 Ply Yarn (Plain Yarn Feeder)
Stitch Adjustor Dial: 4.

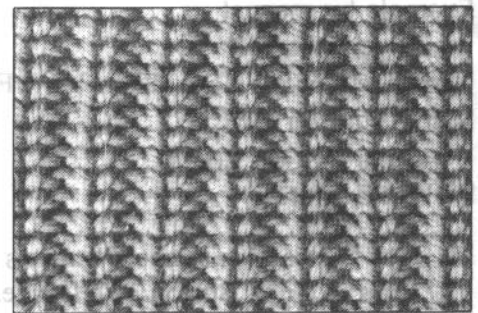

* Use the Cast-on Comb.

HOW TO KNIT.

1. Press in Button II at left side of the carriage. (Carriage is positioned at right side)
2. Press in the Tuck Button at right side of the carriage.
3. Set the pattern selector buttons (1, 3, 5, 7, 9 & 11).
4. Set the zigzag dial at 1.
5. Turn the needle selector lever as far as it will go and return it to the original position completely.
6. Slide the carriage and knit one row.
7. Turn the needle selector lever as far as it will go and return it to the original position completely.
8. Slide the carriage and knit one row.

Repeat the steps 7 – 8 to knit the required number of rows.

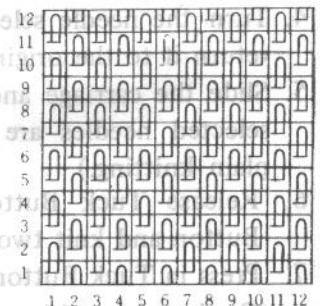

WHOLE TUCK STITCH

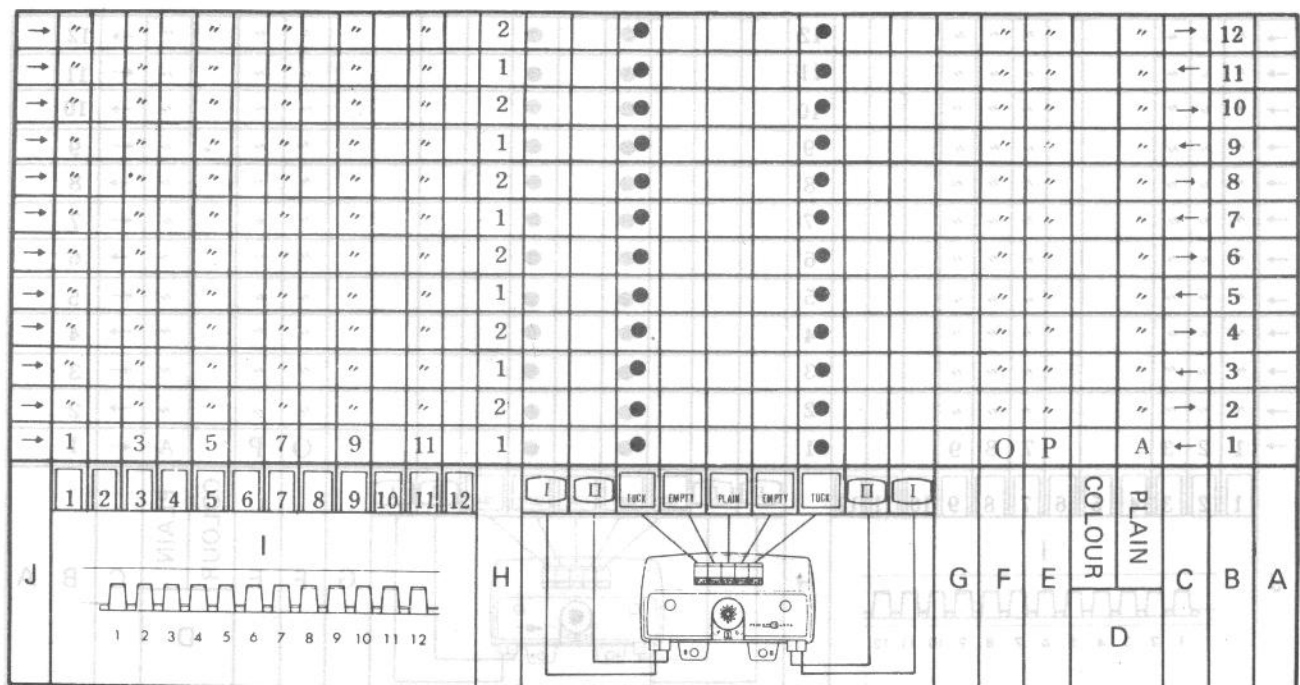

A: Row number of punch card pattern
 B: Number of knitting row
 C: Direction of carriage
 D: Yarn at yarn feeder
 E: Fair isle knob
 F: Thread knitting knob
 G: Thread knitting yarn
 H: Zigzag dial
 I: Pattern selector buttons
 J: Needle selector lever

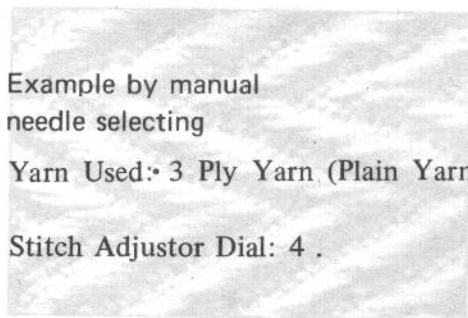

Example by manual needle selecting

Yarn Used: 3 Ply Yarn (Plain Yarn Feeder)

Stitch Adjustor Dial: 4

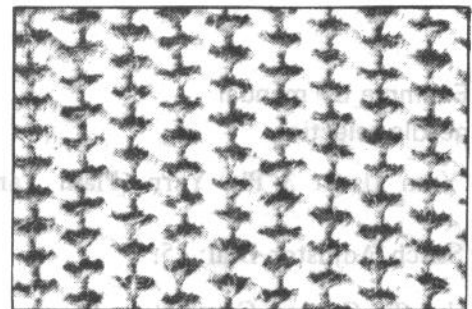

* Use the Cast-on Comb.

HOW TO KNIT:

1. Press in both Tuck Buttons.
2. Set the pattern selector buttons (1, 3, 5, 7, 9 & 11).
3. Set the zigzag dial at 1.
4. Turn the needle selector lever as far as it will go and return it to the original position completely.
5. Slide the carriage and knit one row.
6. Set the zigzag dial at 2.
7. Turn the needle selector lever as far as it will go and return it to the original position completely.
8. Slide the carriage and knit one row.

Repeat the steps 3 – 8 to knit the required number of rows.

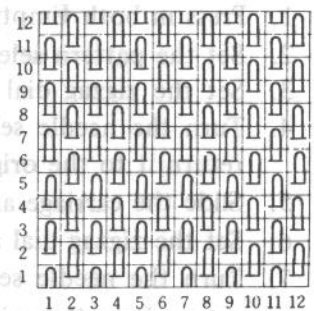

SLIP LOOP TUCK STITCH

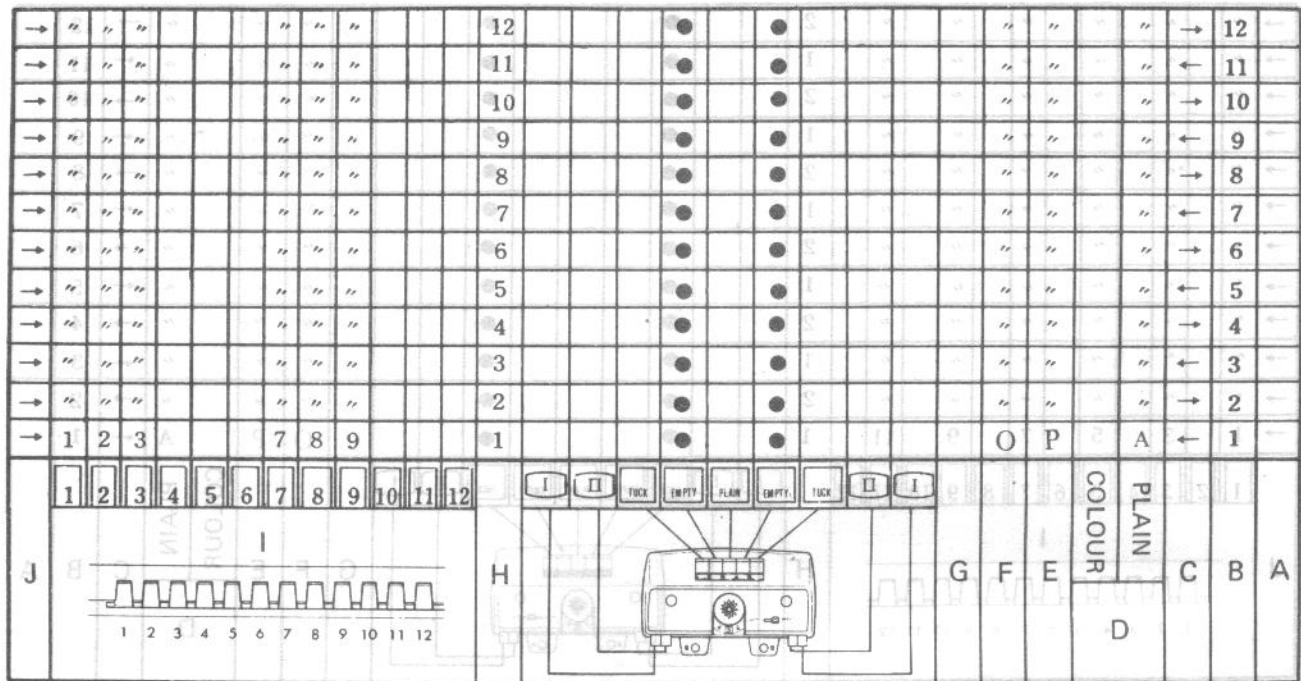

- A: Row number of punch card pattern
- B: Number of knitting row
- C: Direction of carriage
- D: Yarn at yarn feeder
- E: Fair isle knob
- F: Thread knitting knob
- G: Thread knitting yarn
- H: Zigzag dial
- I: Pattern selector buttons
- J: Needle selector lever

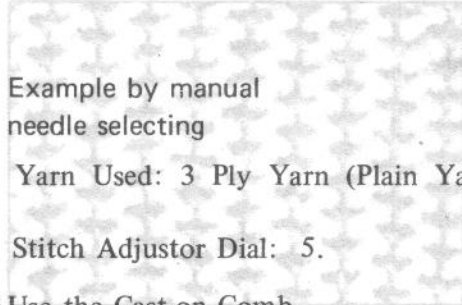

Example by manual
needle selecting

Yarn Used: 3 Ply Yarn (Plain Yarn Feeder)

Stitch Adjustor Dial: 5.

* Use the Cast-on Comb.

HOW TO KNIT.

1. Press in both Empty Buttons.
2. Set the pattern selector buttons (1, 2, 3, 7, 8 & 9).
3. Set the zigzag dial at 1.
4. Turn the needle selector lever as far as it will go and return it to the original position completely.
5. Slide the carriage and knit one row.
6. Set the zigzag dial at 2.
7. Turn the needle selector lever as far as it will go and return it to the original position completely.
8. Slide the carriage and knit one row.
9. Repeat the above steps 3-8 until the zigzag dial shows 12.
10. Then return the zigzag dial one pitch at every row until the zigzag dial shows 1.

Repeat the above steps 3-10 and knit the required number of rows.

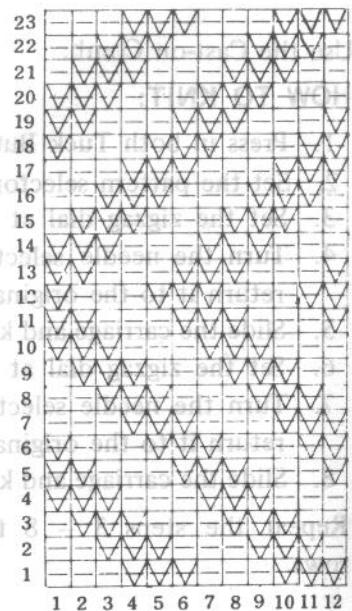
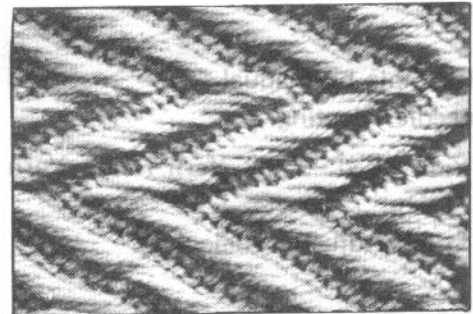

TUCK STITCH COLOUR COMBINATION KNITTING

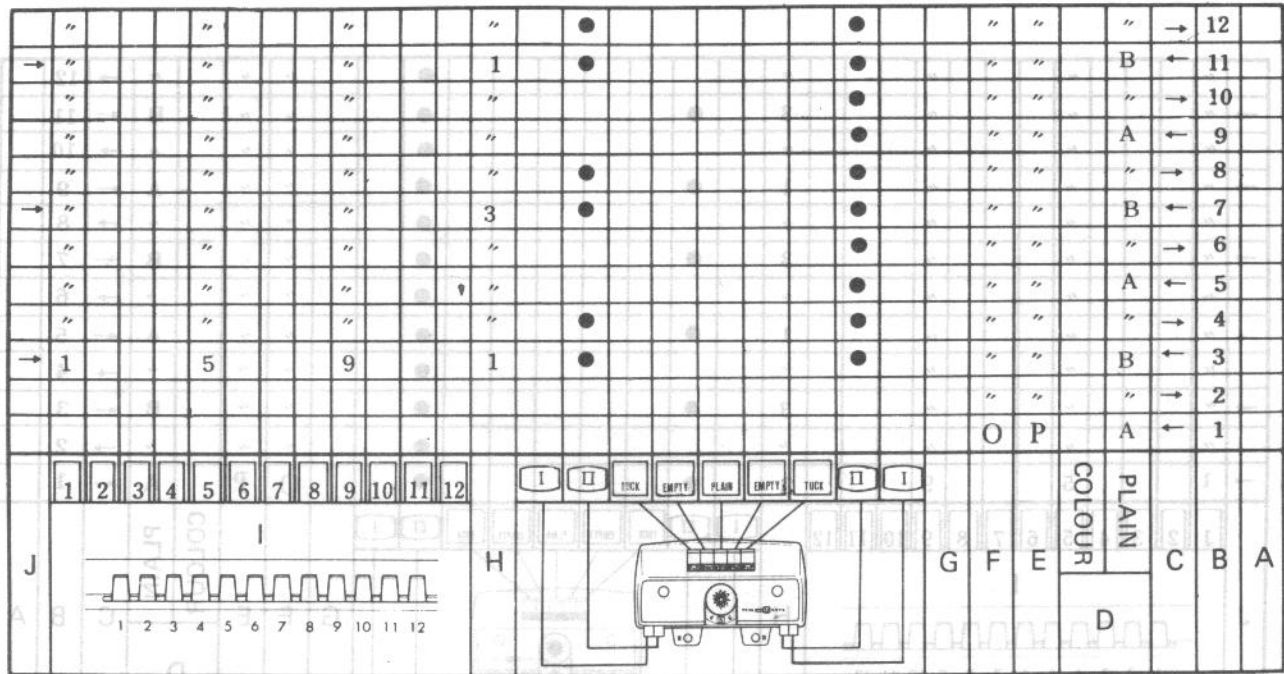

A: Row number of punch card pattern B: Number of knitting row C: Direction of carriage
 D: Yarn at yarn feeder E: Fair isle knob F: Thread knitting knob
 G: Thread knitting yarn H: Zigzag dial I: Pattern selector buttons
 J: Needle selector lever

* Use the Cast-on Comb.

HOW TO KNIT

1. Knit plain stitch for two rows with base yarn A.
2. Press in both Buttons II.
3. Set the pattern selector levers (1, 5 & 9).
4. Change the base yarn to colour yarn B. (In this case, pull out the base yarn from the feeder and hook around end of machine.)
5. Set the zigzag dial at 1.
6. Turn the needle selector lever as far as it will go, and return it to the original position completely.
7. Slide the carriage and knit two rows.
8. Release Button II at left side of the carriage.
9. Change the colour yarn to base yarn A and knit plain stitch for 2 rows. (Hook colour yarn B around other end of machine.)
10. Change the base yarn to colour yarn B and set the zigzag dial at 3.
11. Turn the needle selector lever as far as it will go, and return it to the original position completely.
12. Press in Button II at left side of the carriage.
13. Slide the carriage and knit two rows with colour yarn.
14. Release Button II at left side of the carriage.
15. Change the colour yarn to base yarn A and knit plain stitch for two rows.
16. Press in Button II at left side of the carriage. Repeat the above steps 4-16 to knit the required number of rows.

Example by manual needle selecting

Yarn Used:

A ·· 3 Ply Yarn (Plain Yarn Feeder)

B ·· 3 Ply Yarn (Plain Yarn Feeder)

Stitch Adjustor Dial: 5

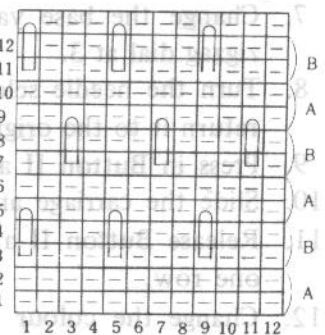
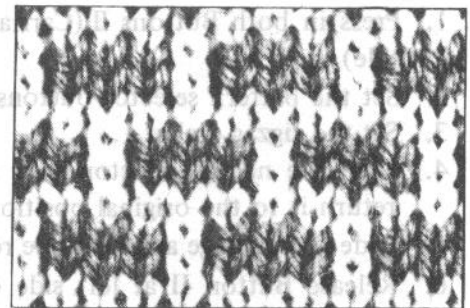

CONTINUOUS TUCK COLOUR COMBINATION PATTERN STITCH

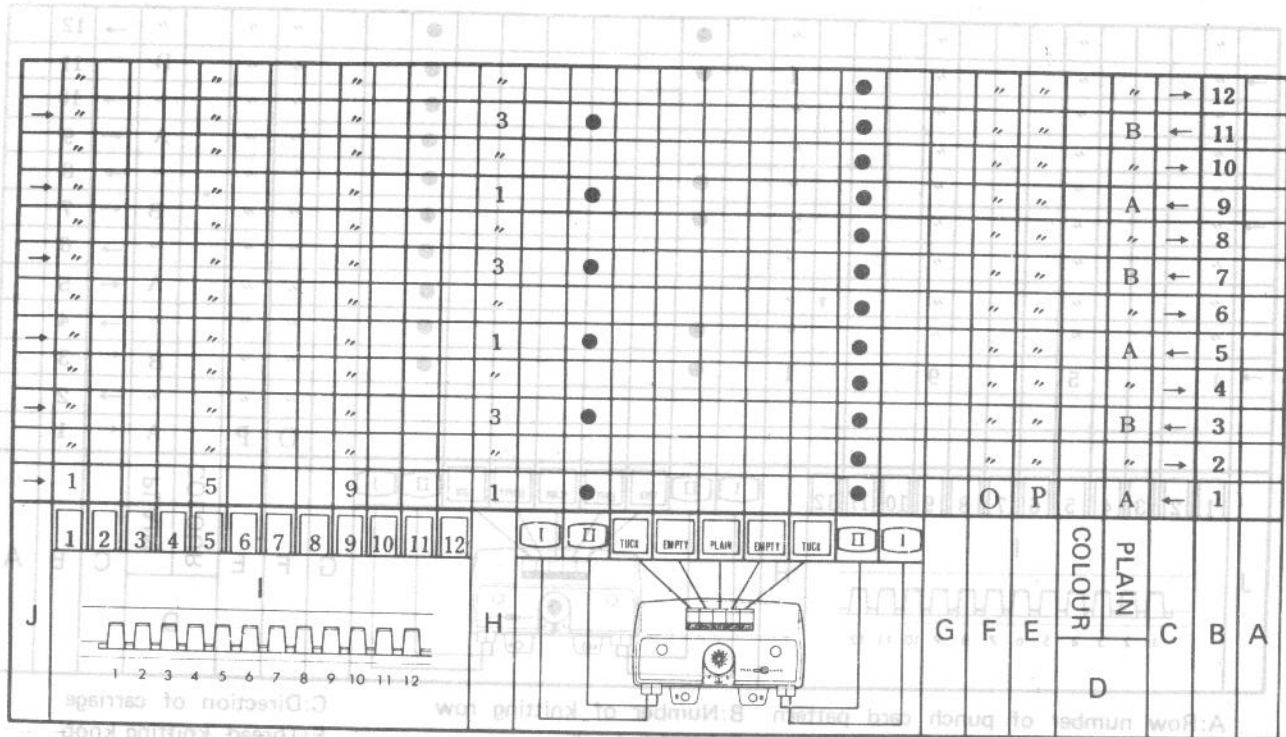

A: Row number of punch card pattern
 B: Number of knitting row
 C: Direction of carriage
 D: Yarn at yarn feeder
 E: Fair isle knob
 F: Thread knitting knob
 G: Thread knitting yarn
 H: Zigzag dial
 I: Pattern selector buttons
 J: Needle selector lever

HOW TO KNIT

Example by manual needle selecting
 Yarn Used:
 A - 3 Ply Yarn (Plain Yarn Feeder)
 B - 3 Ply Yarn (Plain Yarn Feeder)
 Stitch Adjustor Dial: 5.

* Use the Cast-on Comb.

HOW TO KNIT.

1. Press in both Buttons II (Carriage is positioned at right side)
 2. Set the pattern selector buttons (1, 5 & 9).
 3. Set the zigzag dial at 1.
 4. Turn the needle selector lever as far as it will go and return it to the original position completely.
 5. Slide the carriage and knit one row with base yarn A.
 6. Release Button II at left side of the carriage and knit one row.
 7. Change the base yarn to colour yarn B and set the zigzag dial at 3.
 8. Turn the needle selector lever as far as it will go and return it to the original position completely.
 9. Press in Button II at left side of the carriage.
 10. Slide the carriage and knit one row.
 11. Release Button II at left side of the carriage and knit one row.
 12. Change the colour yarn to base yarn A and press in Button II at left side of the carriage.
- Repeat the above steps 3-12 to knit the required number of rows.

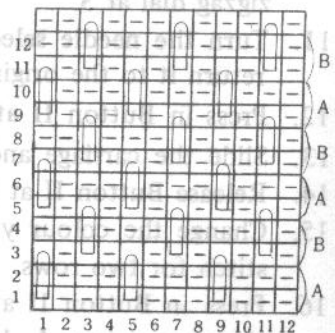
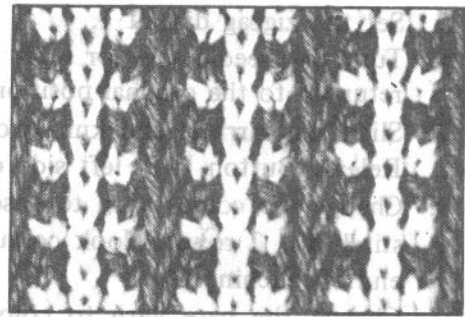

TUCK COLOUR COMBINATION STITCH

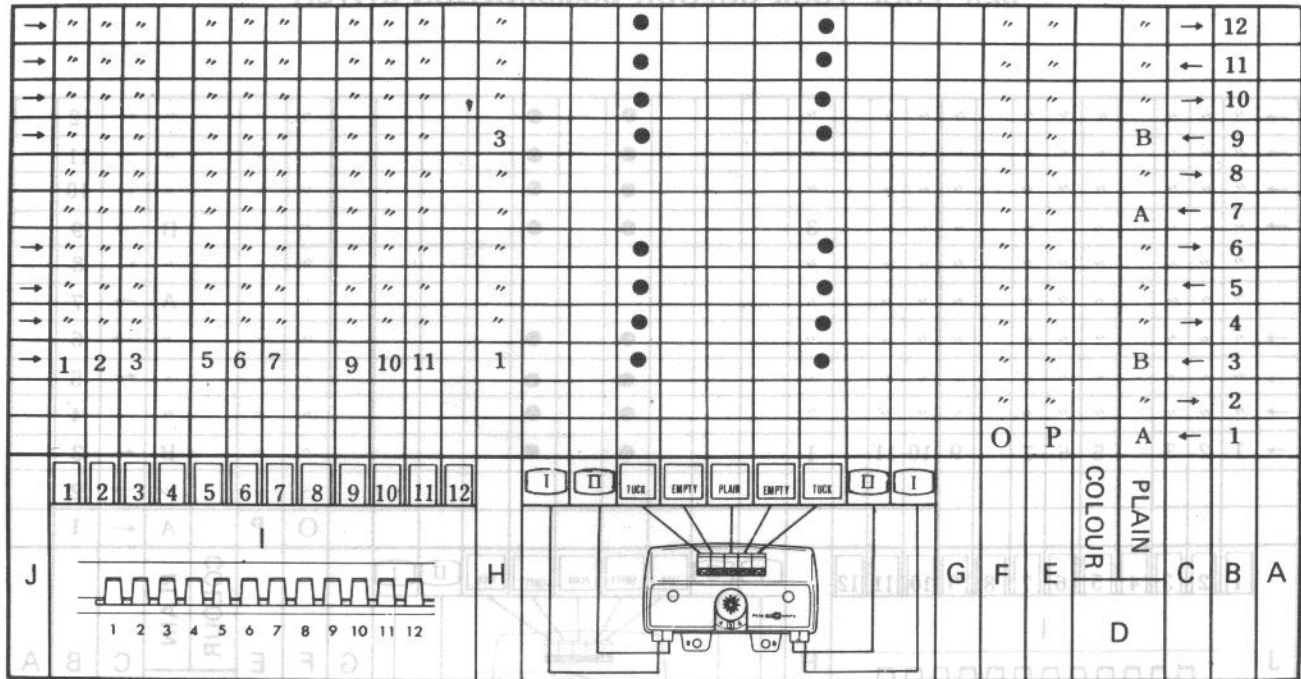

- A: Row number of punch card pattern
- B: Number of knitting row
- C: Direction of carriage
- D: Yarn at yarn feeder
- E: Fair isle knob
- F: Thread knitting knob
- G: Thread knitting yarn
- H: Zigzag dial
- I: Pattern selector buttons
- J: Needle selector lever

* Use the Cast-on Comb.

HOW TO KNIT:

1. Knit plain stitch for two rows with base yarn A.
2. Set the pattern selector buttons (1, 2, 3, 5, 6, 7, 9, 10, 11)
3. Press in both Tuck Buttons.
4. Set the zigzag dial at 1.
5. Turn the needle selector lever as far as it will go and return it to the original position completely.
6. Change the base yarn to colour yarn B and knit four rows selecting the needles in every row.
7. Release both Tuck Buttons.
8. Change the colour yarn to base yarn A and knit plain stitch for two rows.
9. Press in both Tuck Buttons.
10. Set the zigzag dial at 3.
11. Turn the needle selector lever as far as it will go and return it to the original position completely.
12. Change the base yarn to colour yarn B and knit four rows selecting the needles in every row.
13. Release both Tuck Buttons.
14. Change the colour yarn to base yarn A and knit plain stitch for two rows.
15. Press in both Tuck Buttons.
16. Set the zigzag dial at 1.
17. Turn the needle selector lever as far as it will go and return it to the original position completely.
18. Change the base yarn to colour yarn B and knit four rows selecting the needles in every row.

Example by manual needle selecting

Yarn Used:
 A ·· 3 Ply Yarn (Plain Yarn Feeder)
 B ·· 3 Ply Yarn (Plain Yarn Feeder)
 Stitch Adjustor Dial: 5.

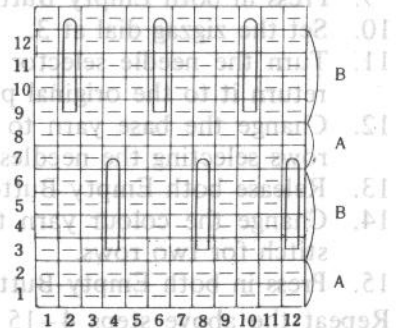
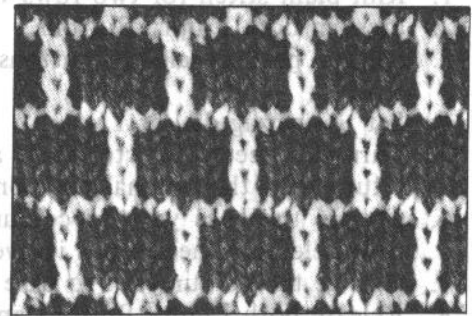

Repeat the steps 7 - 18 to knit the required number of rows.

SLIP LOOP TUCK COLOUR COMBINATION STITCH

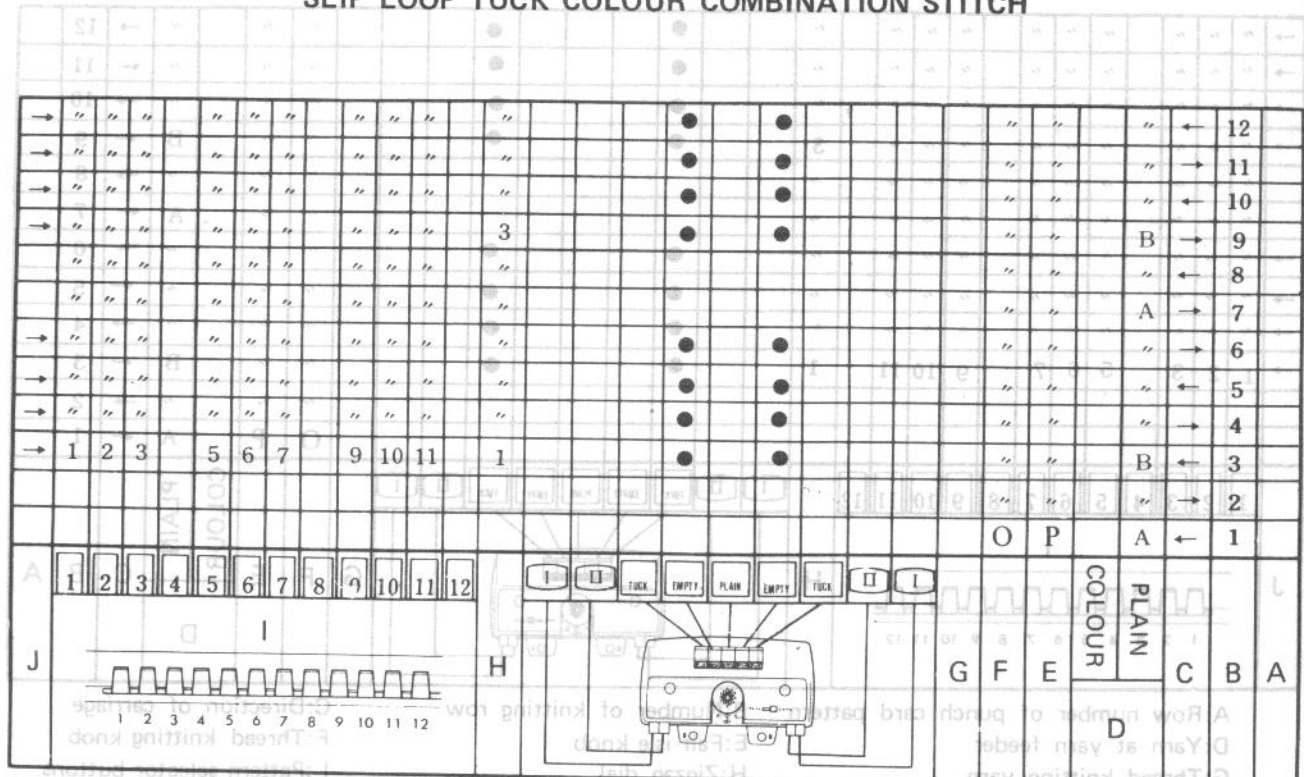

A: Row number of punch card pattern B: Number of knitting row
 D: Yarn at yarn feeder E: Fair isle knob
 G: Thread knitting yarn H: Zigzag dial
 J: Needle selector lever I: Pattern selector buttons

Example by manual
 needle selecting

Yarn Used; A . . . 3 Ply Yarn (Plain Yarn Feeder)
 B . . . 3 Ply Yarn (Plain Yarn Feeder)

Stitch Adjustor Dial: 5.

* Use the Cast-on Comb.

HOW TO KNIT:

1. Knit plain stitch for two rows with base yarn A.
2. Press in both Empty Buttons.
3. Set the pattern selector buttons (1, 2, 3, 5, 6, 7, 9, 10 & 11).
4. Set the zigzag dial at 1.
5. Turn the needle selector lever as far as it will go and return it to the original position completely.
6. Change the base yarn to colour yarn B and knit four rows selecting the needles in every row.
7. Change the colour yarn to base yarn A.
8. Release both Empty Buttons and knit two rows.
9. Press in both Empty Buttons.
10. Set the zigzag dial at 3.
11. Turn the needle selector lever as far as it will go and return it to the original position completely.
12. Change the base yarn to colour yarn B and knit four rows selecting the needles in every row.
13. Release both Empty Buttons.
14. Change the colour yarn to base yarn A and knit plain stitch for two rows.
15. Press in both Empty Buttons.

Repeat the above steps 4-15 to knit the required number of rows.

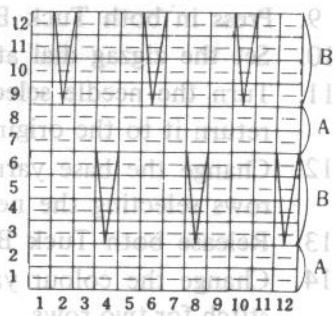
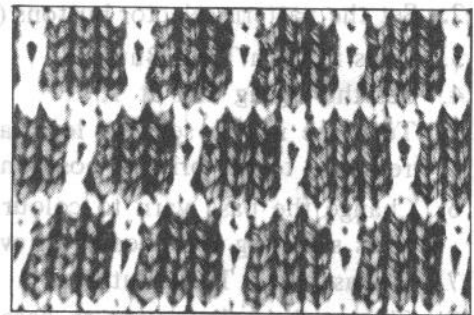

THREAD KNITTING (WEAVING)
OPEN PATTERN KNITTING

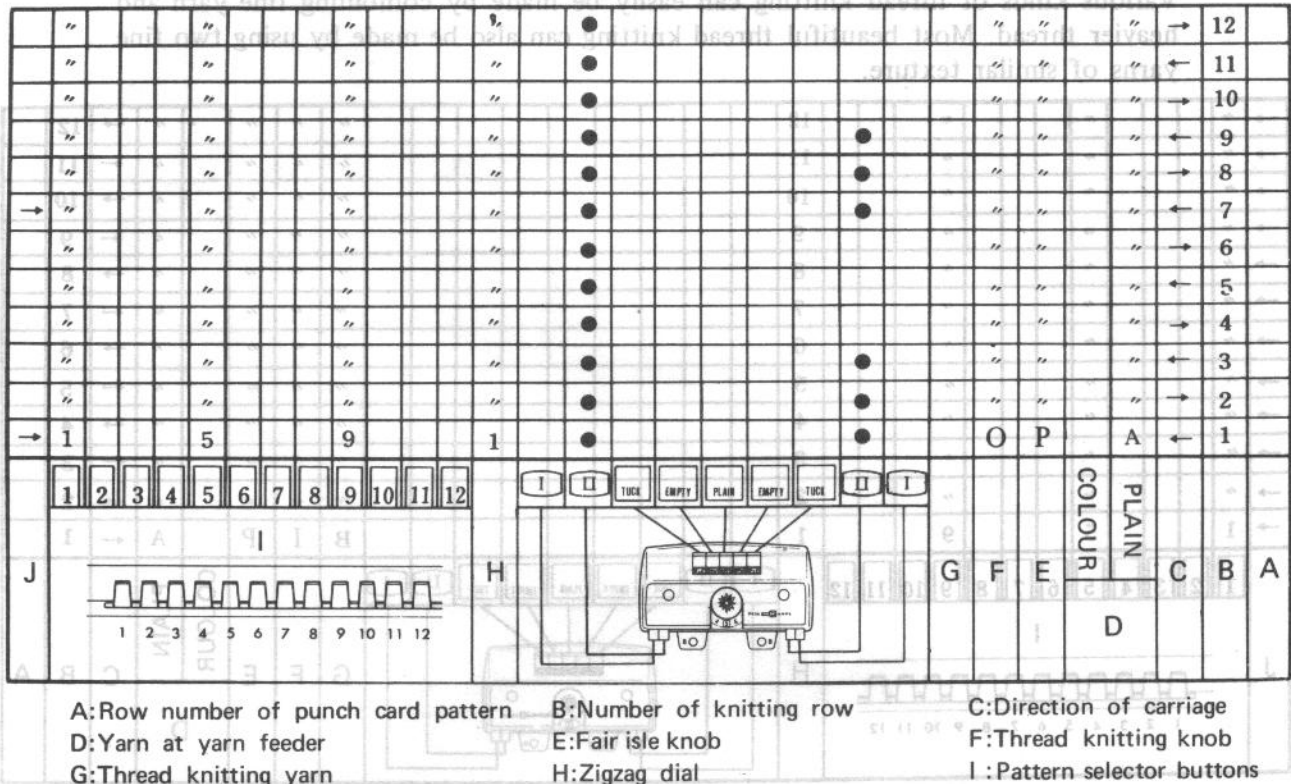

Example by manual needle selecting

Yarn Used : Very Thin (Plain Yarn Feeder)

Stitch Adjustor Dial : 4

* Use the Cast-on Comb.

HOW TO KNIT.

1. Set the pattern selector buttons (1, 5 & 9).
2. Set the zigzag dial at 3.
3. Turn the needle selector lever as far as it will go and return it to the original position completely.
4. Lift stitch off selected needles and hook onto adjacent needles. Push empty needles back to A position.
5. Set the zigzag dial at 1.
6. Press in both Buttons II.
7. Turn the needle selector lever as far as it will go and return it to the original position completely.
8. Slide the carriage and knit three rows.
9. Release Button II at right side on the carriage.
10. Slide the carriage and knit plain stitch for three rows.
11. Press in Button II at right side of the carriage.

Repeat the steps 7 - 11 to knit the required number of rows.

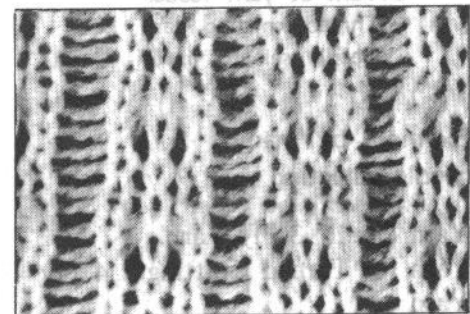

Stitch Adjustor Dial: 6
 * Use the Cast-on Comb

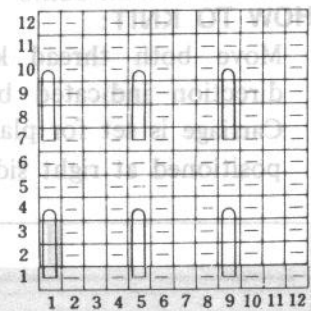

THREAD KNITTING (WEAVING)

By special combination with the needle selector buttons, fabric with less sidewise elasticity which is suitable for knitted suit, can be made easily.

Various kinds of thread knitting can easily be made by combining fine yarn and heavier thread. Most beautiful thread knitting can also be made by using two fine yarns of similar texture.

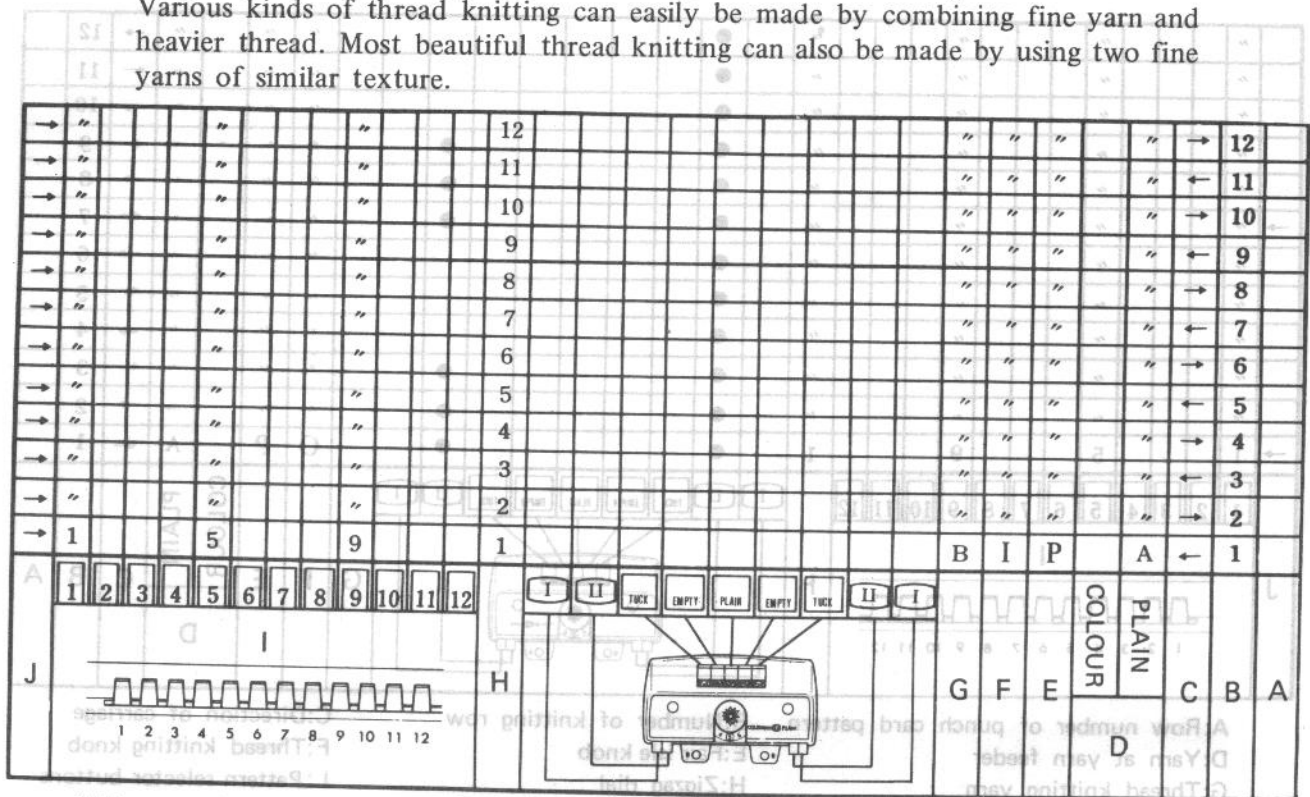

- A: Row number of punch card pattern
- B: Number of knitting row
- C: Direction of carriage
- D: Yarn at yarn feeder
- E: Fair isle knob
- F: Thread knitting knob
- G: Thread knitting yarn
- H: Zigzag dial
- I: Pattern selector buttons

Example by manual needle selecting

Yarn Used: 3 Ply Yarn.
Yarn for Thread Knitting: 4 Ply Yarn

Stitch Adjustor Dial: 6.

*Use the Cast-on Comb

HOW TO KNIT:

Move both thread knitting knobs in the direction indicated by arrow.

Carriage is set for plain knitting (Carriage is positioned at right side.)

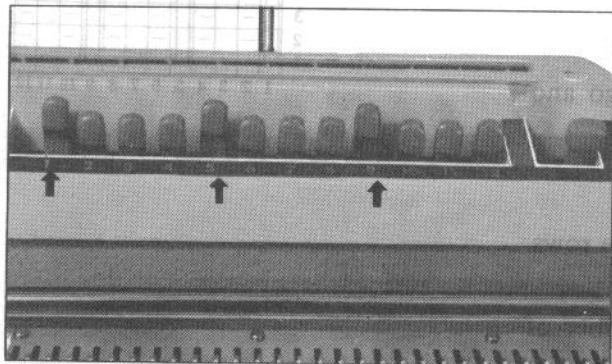

Fig. 2

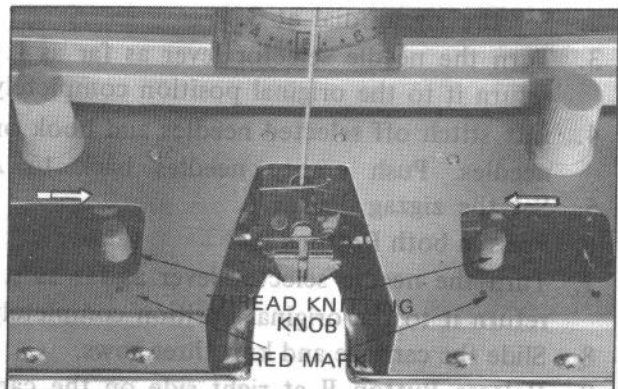
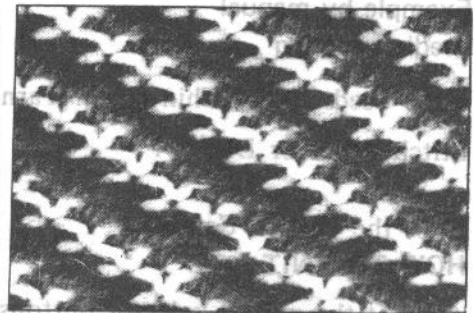
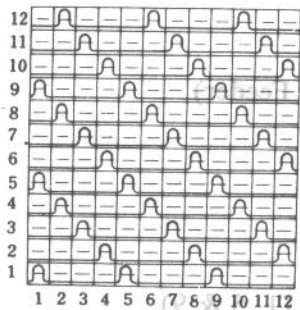

Fig. 1

Set the pattern selector buttons (1, 5, 9) toward the position indicated by arrow.

Zigzag dial: Set to 1

Turn the needle selector lever as far as it will go and select the needles.
Return the needle selector lever to the original position completely.

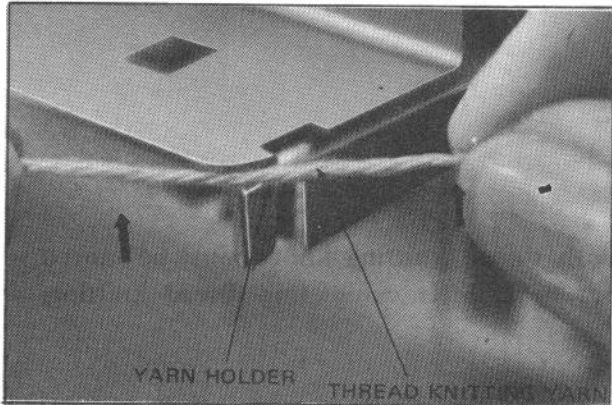

Fig. 4

Place the thread knitting yarn across the selected needle at D position, and hook the yarn on the yarn holder at left side of the machine.

Note:

Thread knitting yarn should be placed close to the sinker hooks.

Place the thread knitting yarn from the carriage side and lead it to the take up spring.

When using heavy yarn for thread yarn, set the red line of tension adjustor dial to mark (-), and knit with holding the end of yarn lightly while knitting across row.

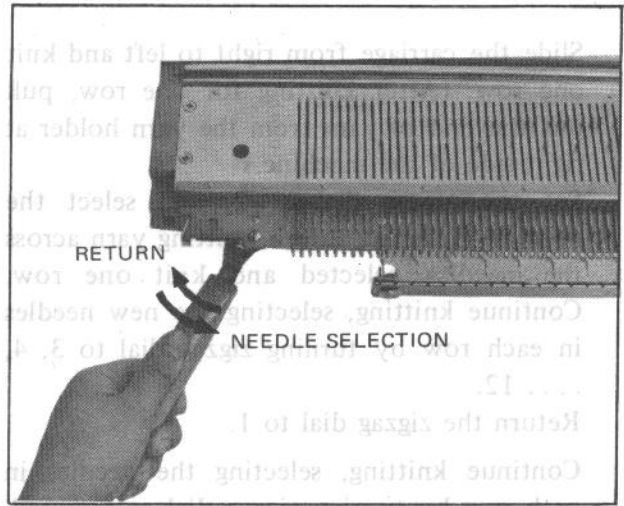

Fig. 3

Pass the thread knitting yarn through another take-up spring and nip the end of yarn in the yarn holder at right side of the machine.

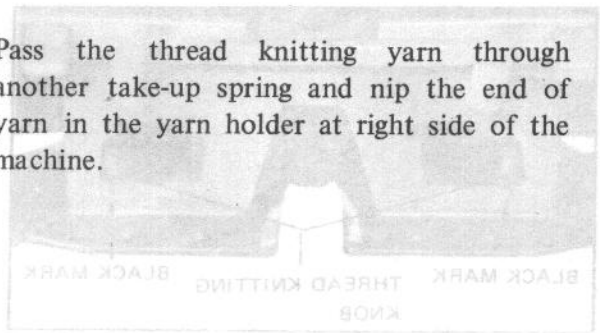

Fig. 8

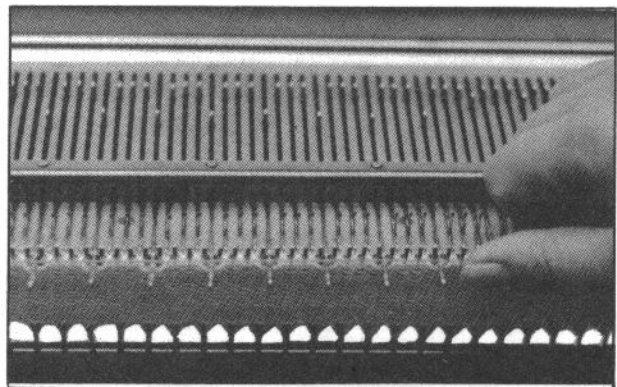

Fig. 5

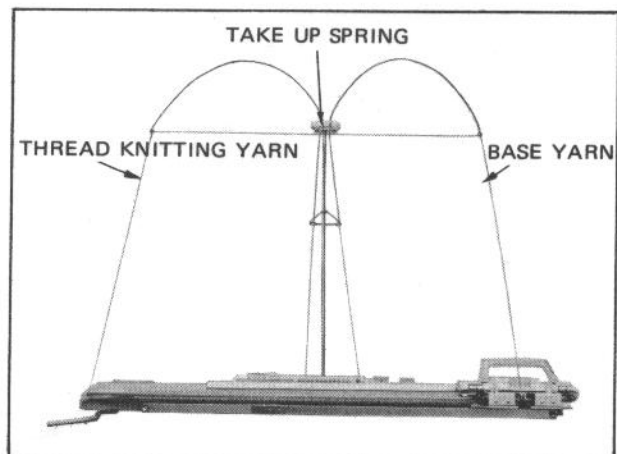

Fig. 6

Slide the carriage from right to left and knit one row. (After knitting for one row, pull out the end of yarn from the yarn holder at right side of the machine.)

Set the zigzag dial at 2, and select the needles. Place the thread knitting yarn across the needles selected and knit one row. Continue knitting, selecting the new needles in each row by turning zigzag dial to 3, 4, 12.

Return the zigzag dial to 1.

Continue knitting, selecting the needles in each row by turning zigzag dial as required.

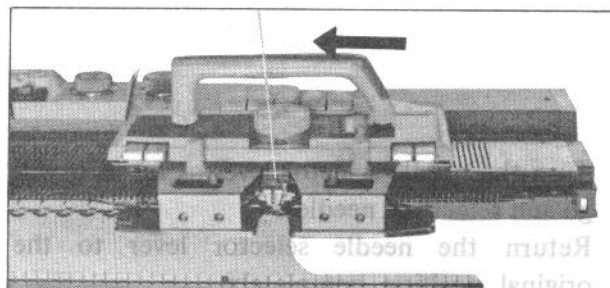

Fig. 7

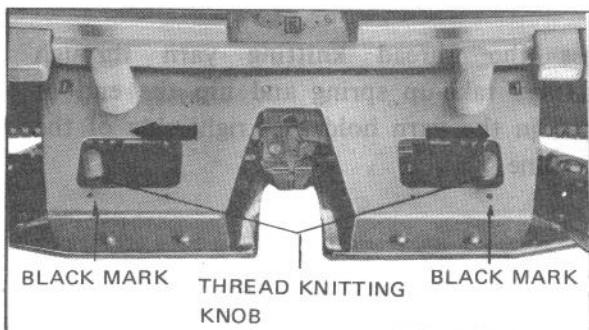
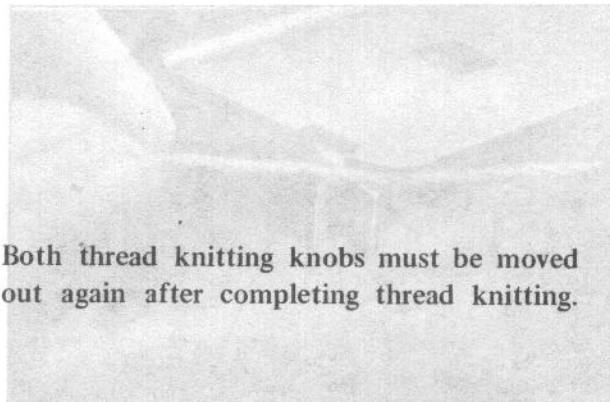

Fig. 8



Both thread knitting knobs must be moved out again after completing thread knitting.

Fig. 4

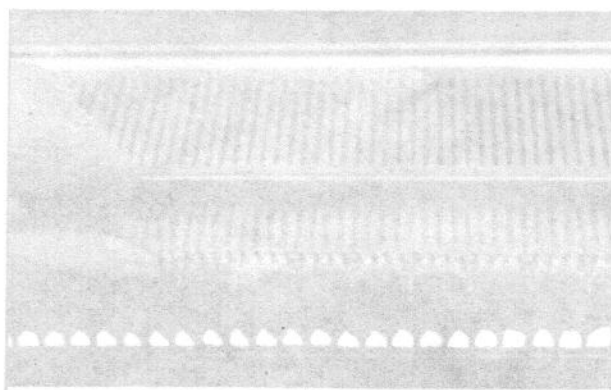

Fig. 5

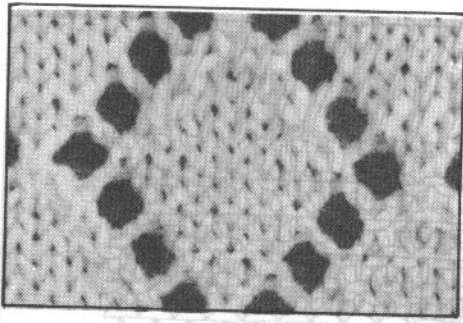

Fig. 6

Place the thread knitting yarn across the selected needle at D position, and hook the yarn on the yarn holder at left side of the machine.

Note:
Thread knitting yarn should be placed close to the sinker hooks.
Place the thread knitting yarn from the carriage side and lead it to the take up spring.
When using heavy yarn for thread yarn, set the red line of tension adjuster dial to mark (—) and knit with holding the end of yarn lightly while knitting across row.

MANUAL LACE PATTERN KNITTING



HOW TO KNIT.

1. Carriage is set as for plain knitting.
2. To make a hole. Transfer pattern stitches to adjacent needles leaving the empty needle in working position and knit two rows. (stitches are transferred every 2nd row.)
3. Different design can be produced by changing the position of holes.
4. When using lace yarn or synthetic yarn, more beautiful and easier knitting can be accomplished by using knitting weights and attaching knitting wax to take-up spring.

16																
15		○	△			△	○			○	△					
14																
13	△	○						○	△							
12																
11		△	○					○	△							
10																
9		△	○					○	△							
8																
7				○	△								○	△		
6																
5			○	△									○	△		
4																
3		○	△					○	△							
2																
1	○	△				△	○			○	△					
	1	2	3	4	5	6	7	8	9	10	11	12	13	14	15	16

Yarn Used: Three Ply Yarn(Plain Yarn Feeder)
Stitch Adjustor Dial: 5

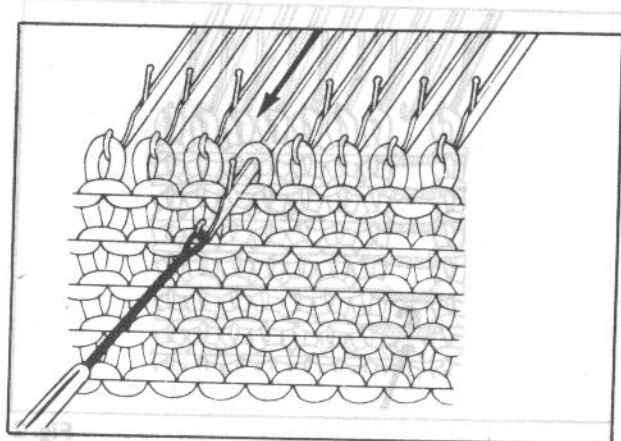

Fig. 1

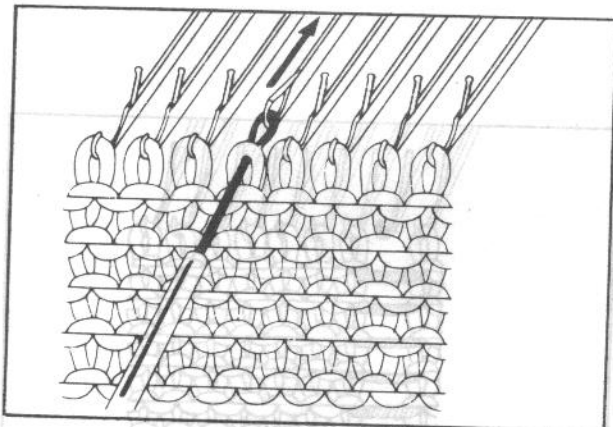

Fig. 2

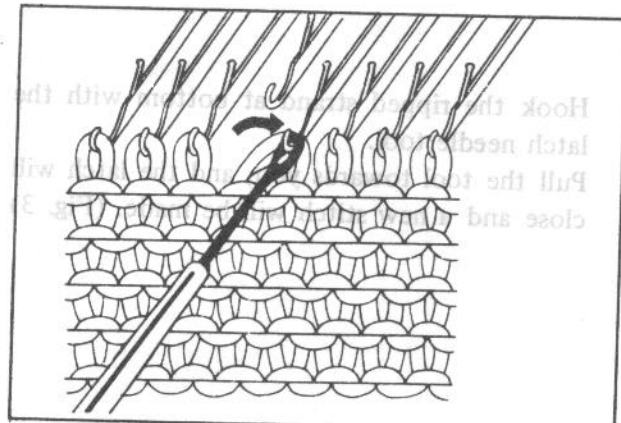

Fig. 3

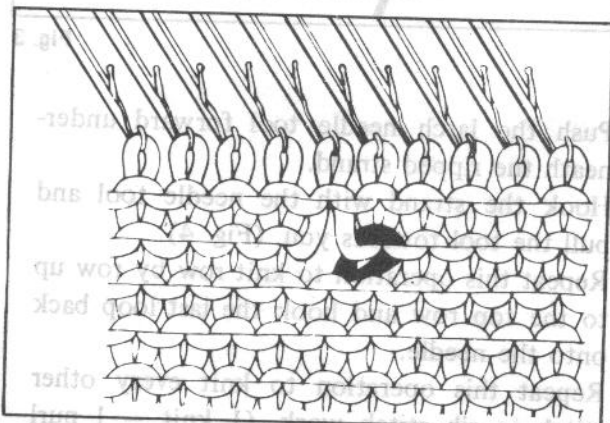

Fig. 4

HOW TO KNIT.

Insert the latch needle tool into the stitch ▶
 from the purl side as shown in Fig. 1.
 (Make rib stitch knitting from the next
 needle on the left end.)

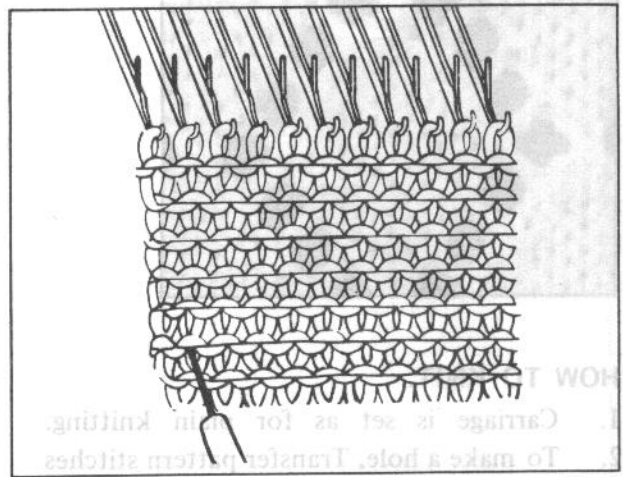

Fig. 1

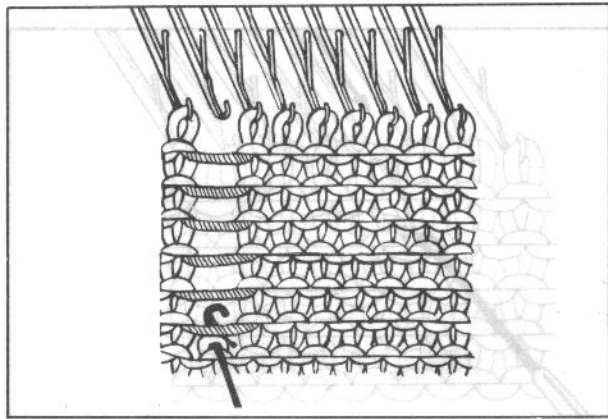
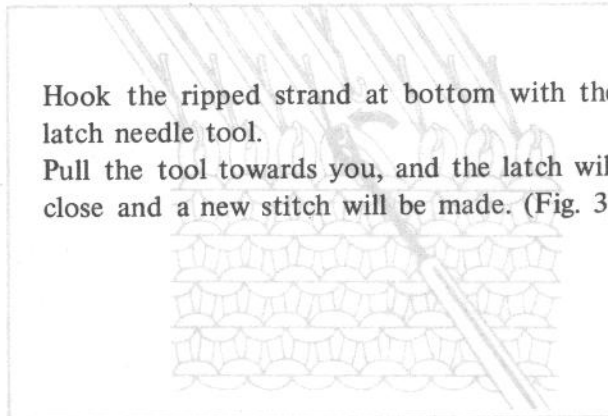

Fig. 2

◀ Unhook the knitted stitch on the latch
 needle with the needle tool inserted, and rip
 the stitches until just before the row on the
 latch needle tool by pulling down the fabric
 lightly with one hand and then by pulling
 down the latch needle tool with it inserted
 in the stitch firmly. (Fig. 2)



▶ Hook the ripped strand at bottom with the
 latch needle tool.
 Pull the tool towards you, and the latch will
 close and a new stitch will be made. (Fig. 3)

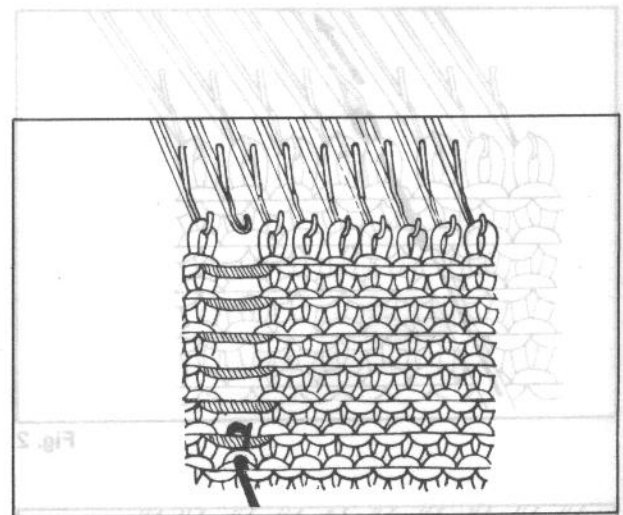

Fig. 3

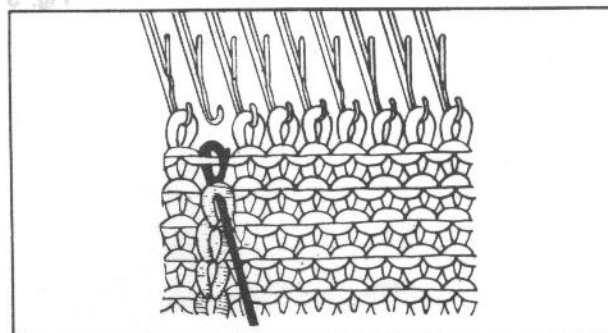
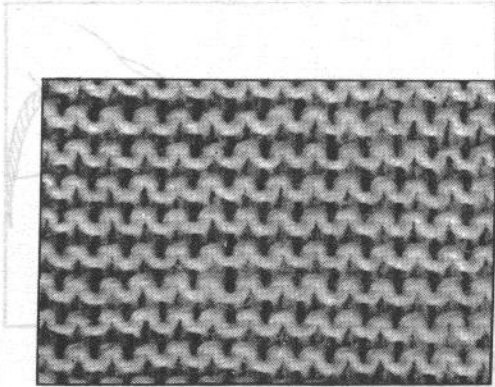

Fig. 4

◀ Push the latch needle tool forward under-
 neath the ripped strand.
 Hook the strand with the needle tool and
 pull the tool towards you. (Fig. 4)
 Repeat this operation to knit row by row up
 to the top row and hook the last loop back
 onto the needle.
 Repeat this operation to knit every other
 stitch in rib stitch work. (1 knit — 1 purl
 rib)

PURL STITCH KNITTING



HOW TO KNIT

1. Wind yarn around three needles and pull these needles together.

2. Push in right needle.

3. Hold end of yarn.

Knit. Set.

12															
11															
10															
9															
8															
7															
6															
5															
4															
3															
2															
1															
	1	2	3	4	5	6	7	8	9	10	11	12			

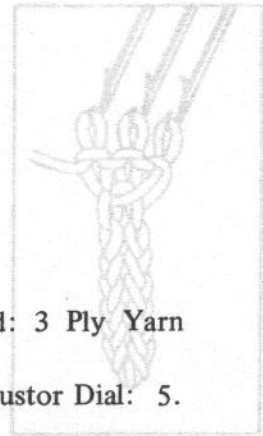

Yarn Used: 3 Ply Yarn
Stitch Adjustor Dial: 5.

HOW TO KNIT:

1. Carriage is set for plain knitting.
2. Knit 2 rows plain stitch.
3. Insert latch needle tool in the loops of the second row. (Fig. 1)

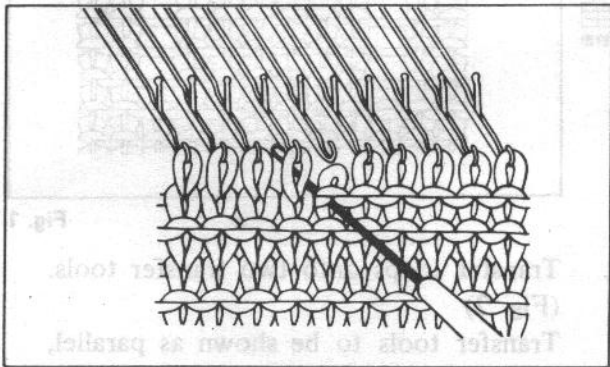

Fig. 2

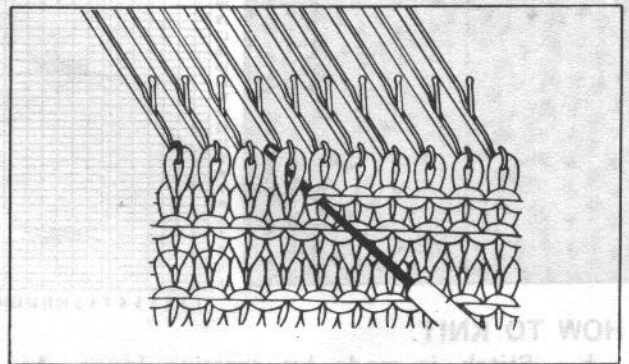

Fig. 1

4. Unhook the stitches on first row from the latch needles. (Fig. 2)

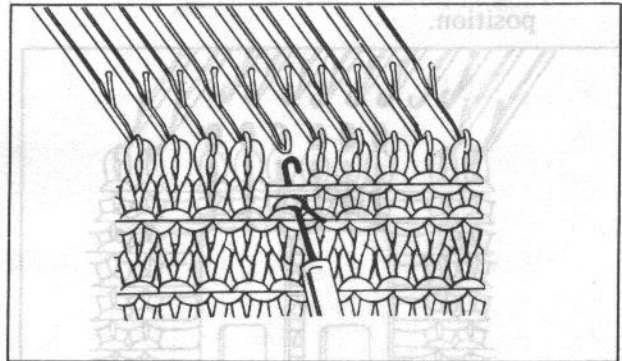

Fig. 3

5. By dropping the latch needle tool, loop of the first row will be unraveled. (Fig. 3)

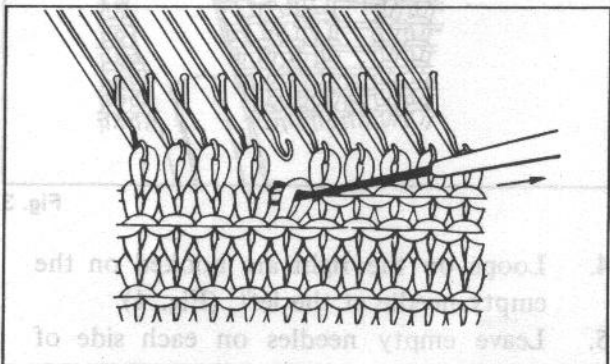

Fig. 4

6. By pulling the latch needle tool, pick up the first row strand and make a loop and hook it on the latch needle. (Fig. 4 & 5)

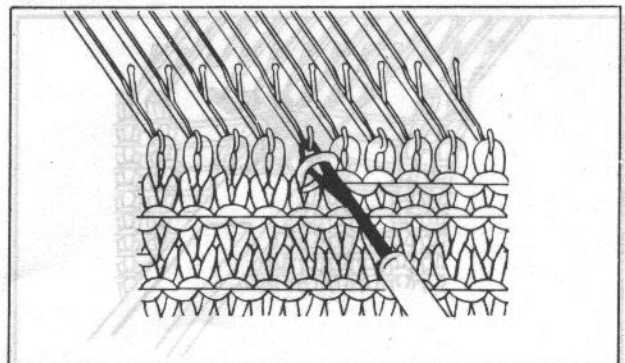
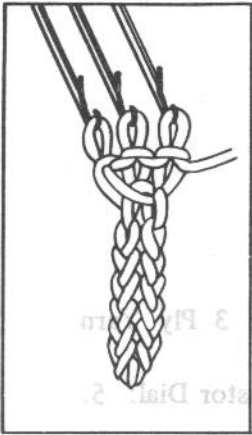

Fig. 5

7. Repeat the steps 3 - 7 for all loops. Repeat the steps 2 - 6 for as many purls as necessary.

CORD KNITTING



HOW TO KNIT

1. Wind yarn around three needles and pull these needles through to E position.
2. Push in right EMPTY button.
3. Hold end of wool below cast on and knit. Set tension to suit yarn.

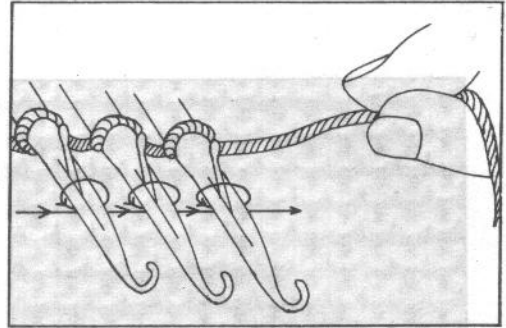

CABLE PATTERN KNITTING

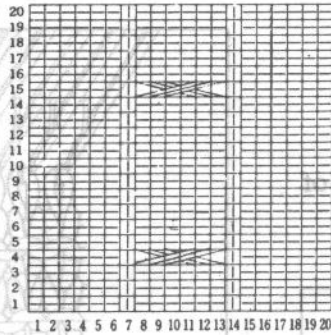
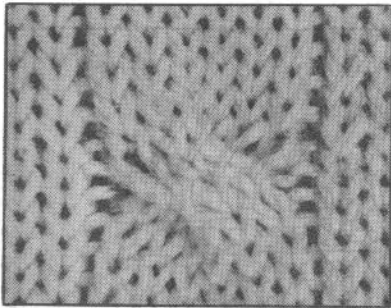

Yarn Used: 3 Ply Yarn (Plain Yarn Feeder)
Stitch Adjustor Dial: 5

HOW TO KNIT.

1. Stitch is made by crossing loops. As shown in Fig. 1, unhook the loops on both sides of the stitches to be crossed for several rows, and place on holding pins. Return empty needles to A position.

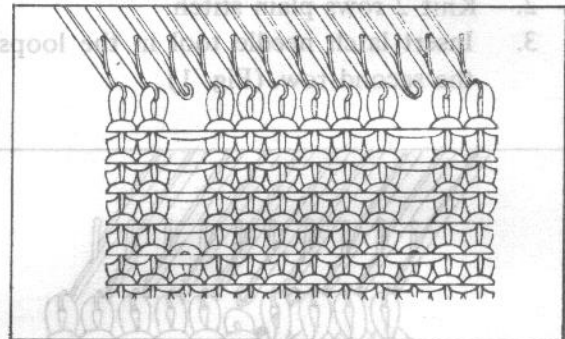

Fig. 1

2. Transfer loops onto two transfer tools. (Fig. 2)
Transfer tools to be shown as parallel, not crossed.

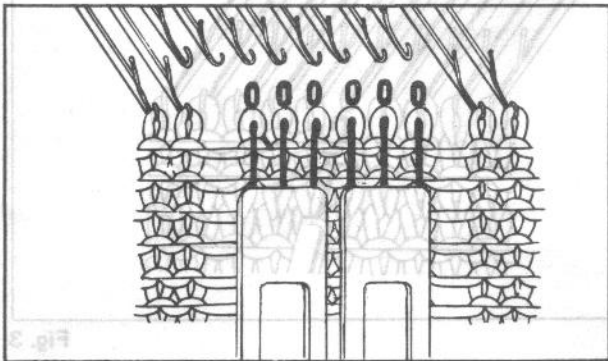

Fig. 2

3. Loops on the left transfer tool are hooked on the empty latch needles at the right. (Fig. 3)

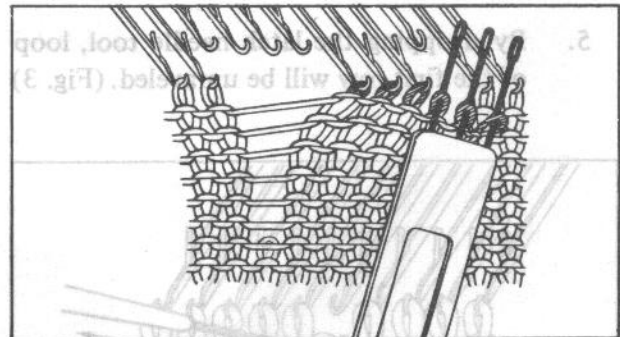

Fig. 3

4. Loops on the right are hooked on the empty needle at the left. (Fig. 4)
5. Leave empty needles on each side of cable in A position until cabling is completed. Knit up purl stitch with latch needle tool if required.

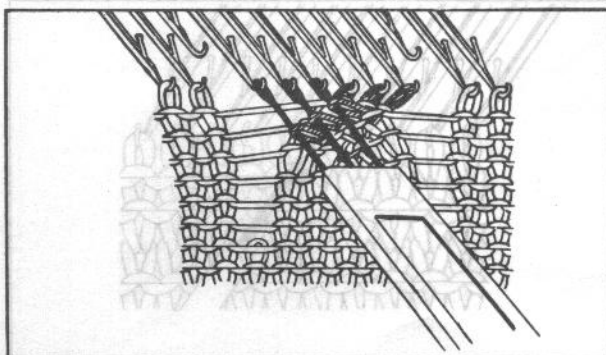

Fig. 4

When knitting the next row after crossing, knitting can be made more easily by pulling out to E position the needles on which the stitches are crossed.

MAINTENANCE OF THE MACHINE

Daily maintenance is required in order to use the machine in good condition for a long time.

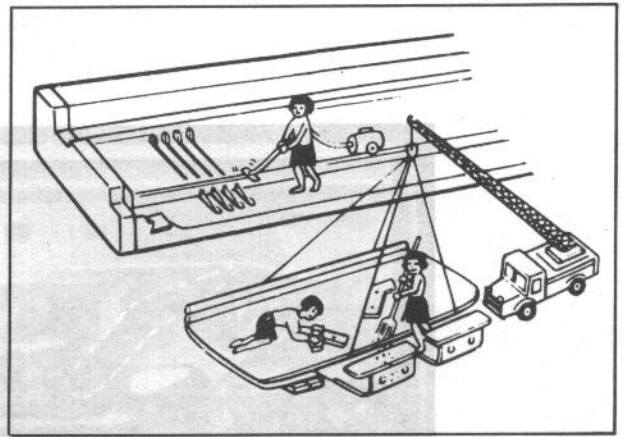

Fig. 1

After using the machine, wipe dirt off the carriage and needle bed completely.

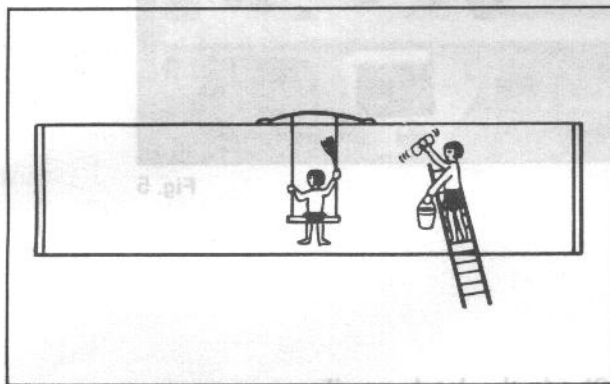

Fig. 2

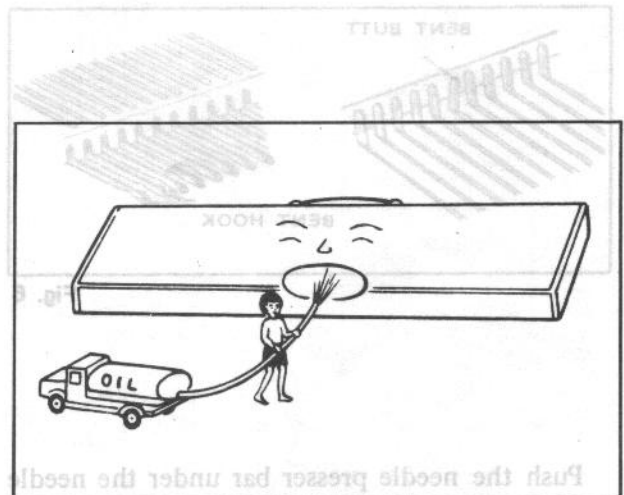

Fig. 3

Oil the machine.

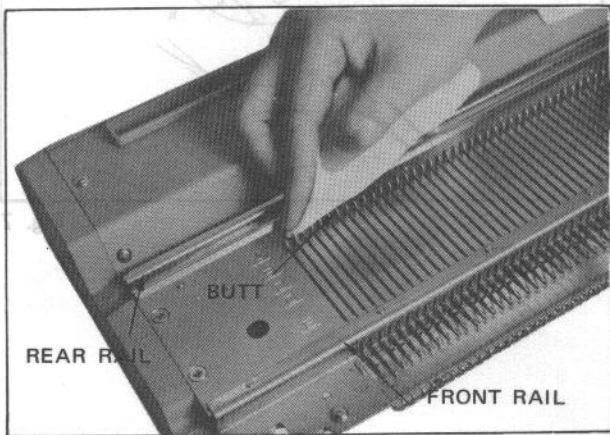
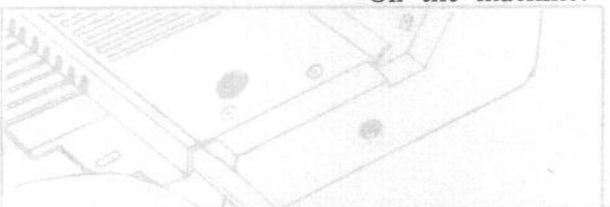

Fig. 4

Never apply oil to the latch and hook of the needle, but to the butt with an oiled rag to avoid excess oiling as shown in Fig. 4. Wipe the back rail surface and the front rail surface with an oiled rag.

Apply oil to the knitting cams on the rear of the carriage (the oblique line), and wipe off excess oil with a rag.

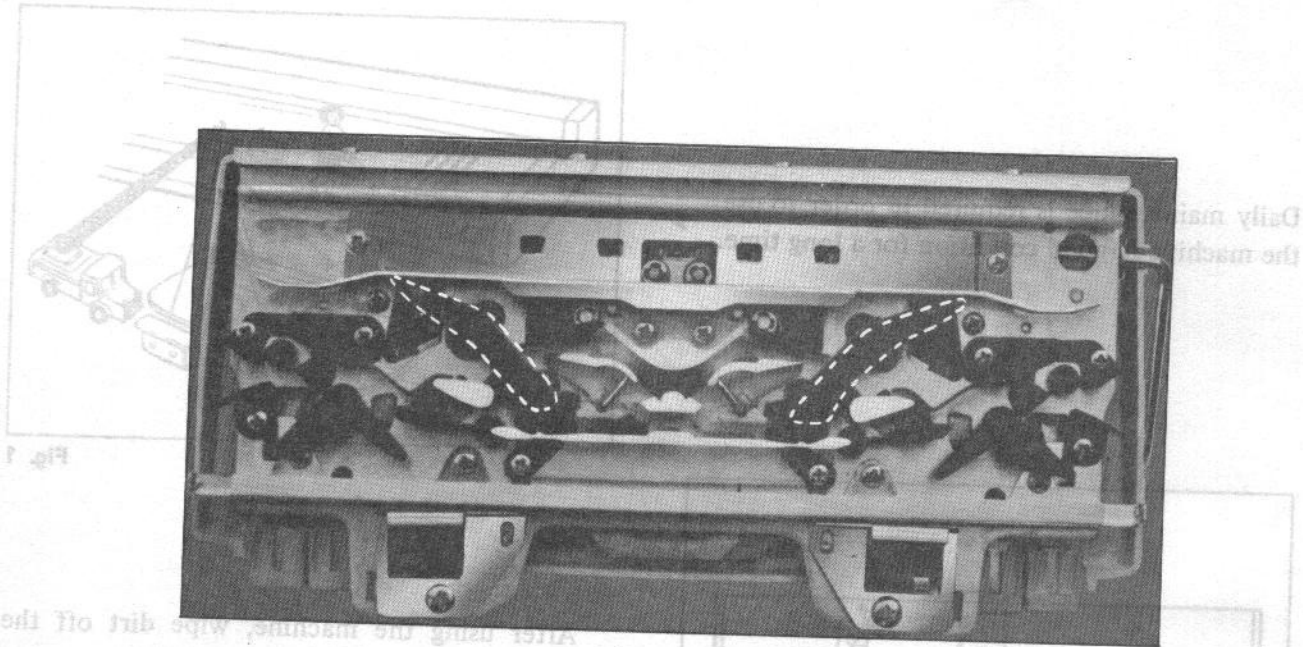

Fig. 5

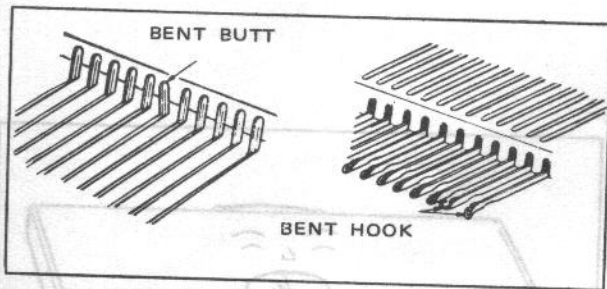

Fig. 6

Push the needle presser bar under the needle bed with a handle of the latch needle tool from one side.

Check the latch needles

- ◀ Replace the needle with a bent butt or a bent hook (You can replace a needle even while knitting.)

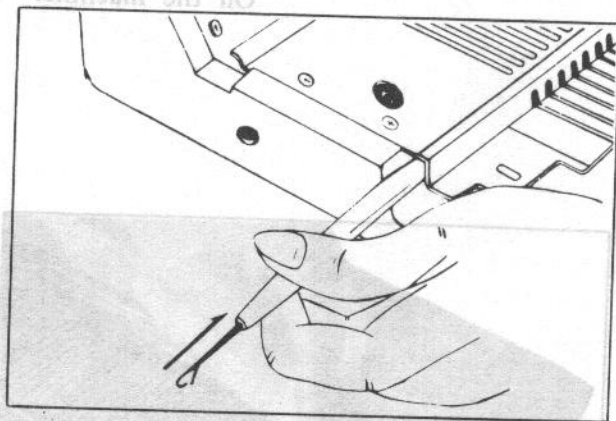

Fig. 7

Pull out the needle presser bar until the other end of the bar is disconnected from the latch needle to be replaced.

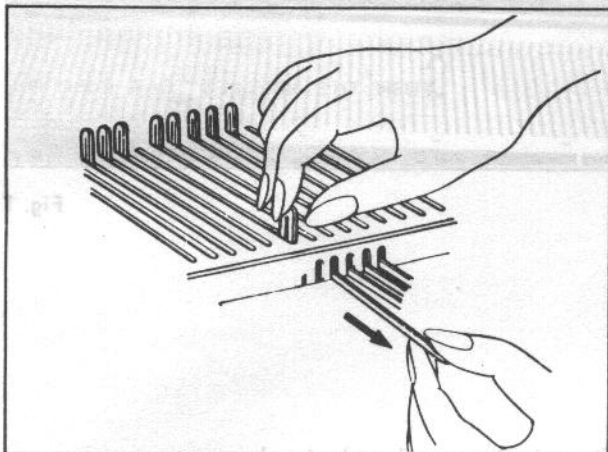

Fig. 9

Push down the needle hook with the left hand, hold the butt and push it away from you.

Move the needle to be replaced in the order 1, 2 and 3 as shown in Fig. 10.

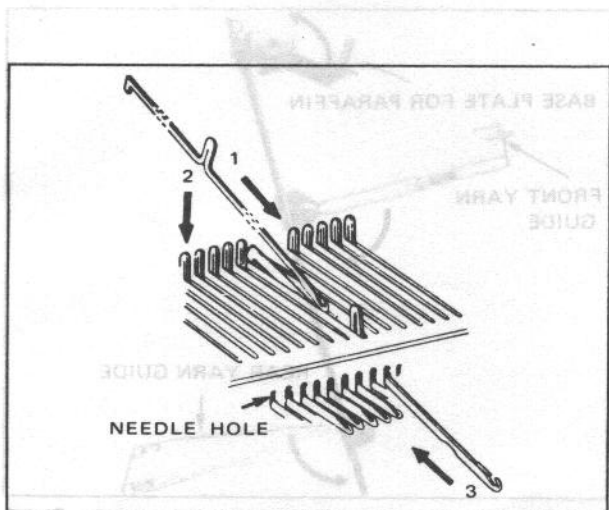

Fig. 11

Pressing down the raised hooks of the needles, return the needle presser bar.

If the needle presser is detached from the needle bed, insert the needle presser with turning concave to this side where it was, as shown in Fig. 12.

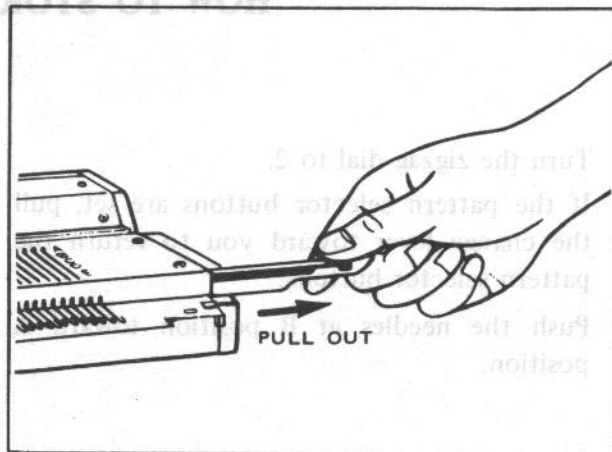

Fig. 8

Pull the latch needle to be replaced out toward you to E position.

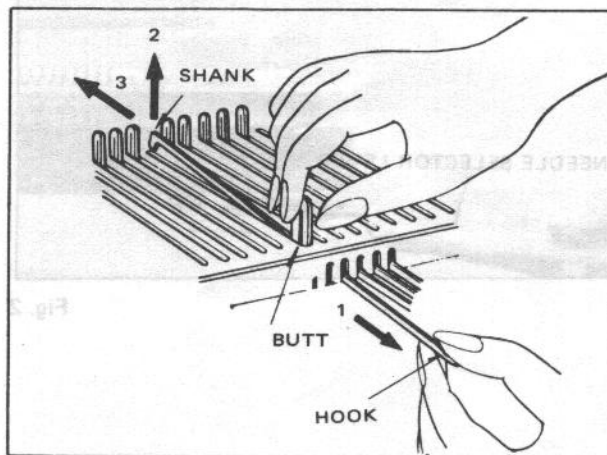

Fig. 10

Pass the new needle through needle hole and pull it out toward you. Insert the shank in the needle bed. (Move the needle in the order 1, 2 and 3 as shown in Fig. 11.)

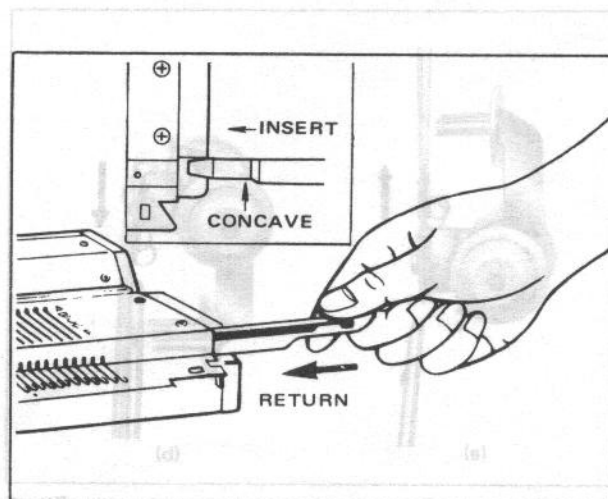

Fig. 12

HOW TO STORE THE MACHINE

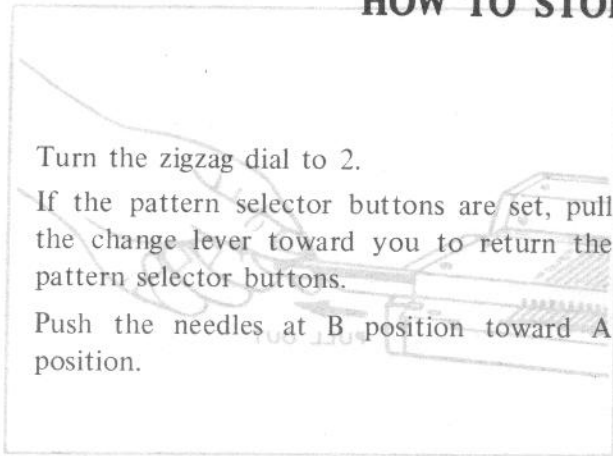

Fig. 8

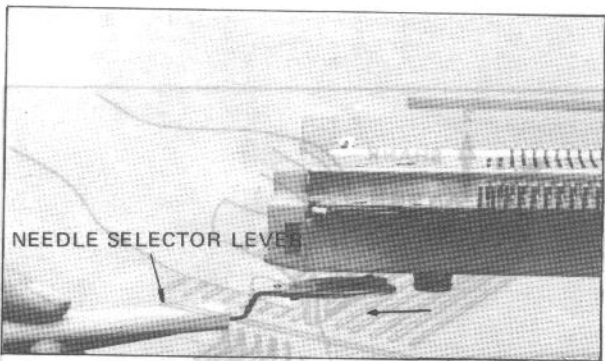

Fig. 2



Fig. 10

Put the front yarn guide downwards as shown in Fig. 3.
Turn the rear yarn guide and base plate for paraffin, pushing it as indicated by arrow.

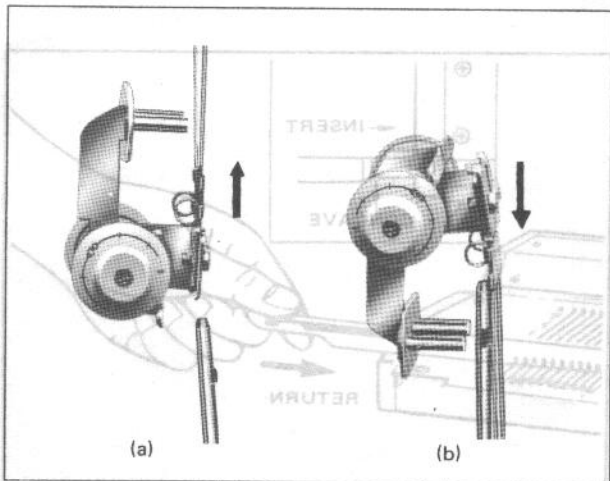

Fig. 4

Fig. 12

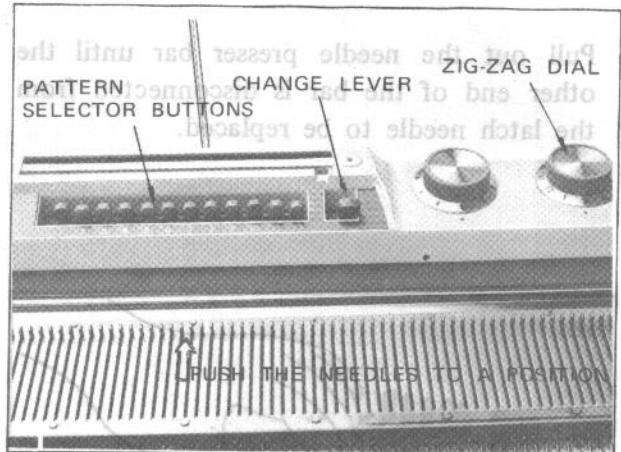

Fig. 1



Detach the needle selector lever.

Push down the needle hook with the left hand, hold the butt and push it away from you.
Move the needle to be replaced in the order 1, 2 and 3 as shown in Fig. 10.

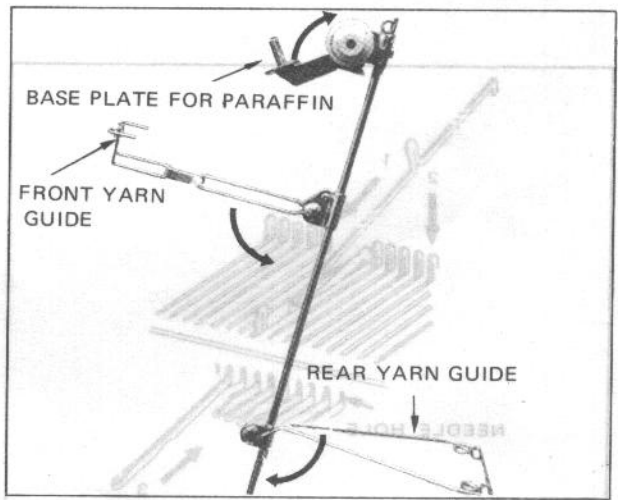

Fig. 3

Fig. 11

- (a) Pull out the take-up spring from the take-up rod.
- (b) Insert the take-up spring upside down in the take-up rod.

Insert the needle into the needle bed, insert the needle presser with turning concave to this side where it was, as shown in Fig. 12.

Pull out the rod from the bottom of the case. ▶

▶ Detach the clamps from the clamping hole on the bottom of the machine in order (1-2) as shown in Fig. 9.

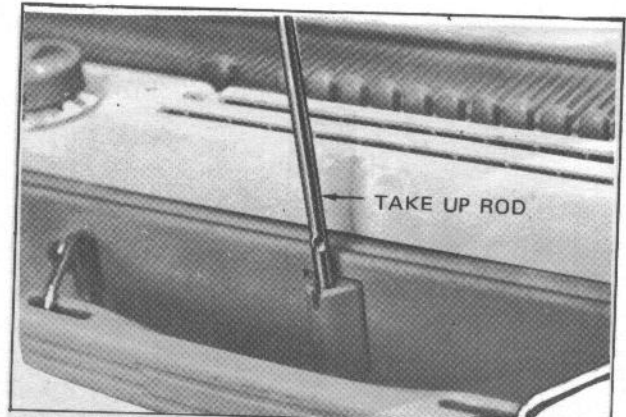

Fig. 5

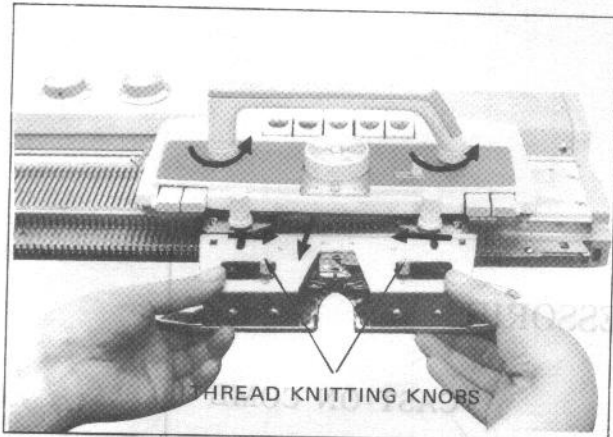

Fig. 6

◀ Remove the fabric presser from the carriage. Turn both thread knitting knobs inwards. Detach the handle from the carriage.

Lock the carriage on the right side of the needle bed with carriage lock in order (1-2-3) as shown in Fig. 7. Return the row counter lever.



Fig. 7

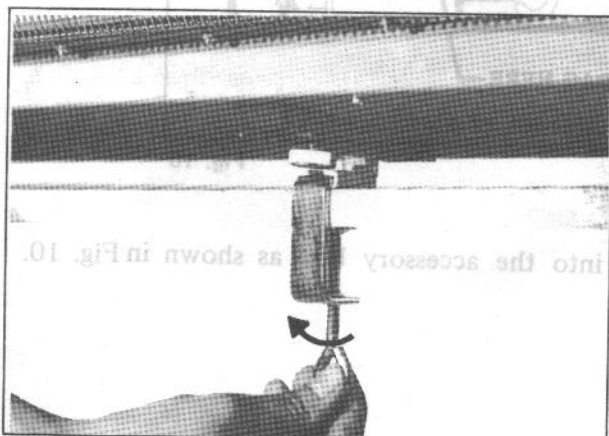

Fig. 8

◀ Detach the clamps from the table.

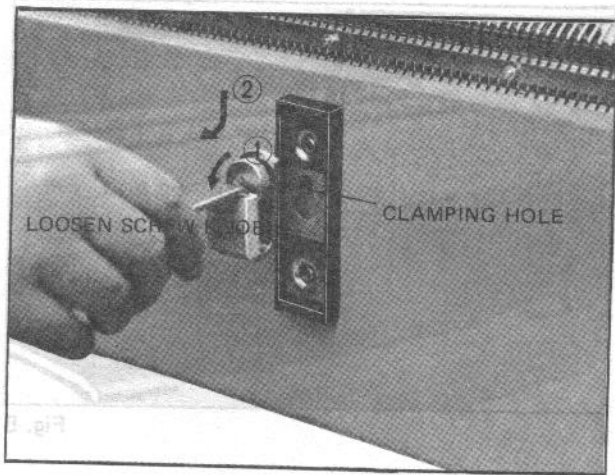

Fig. 9

- ▶ Pull out the rod from the bottom of the case.
- ▶ Detach the clamps from the clamping hole on the bottom of the machine in order (1-2) as shown in Fig. 9.

HOW TO STORE ACCESSORIES

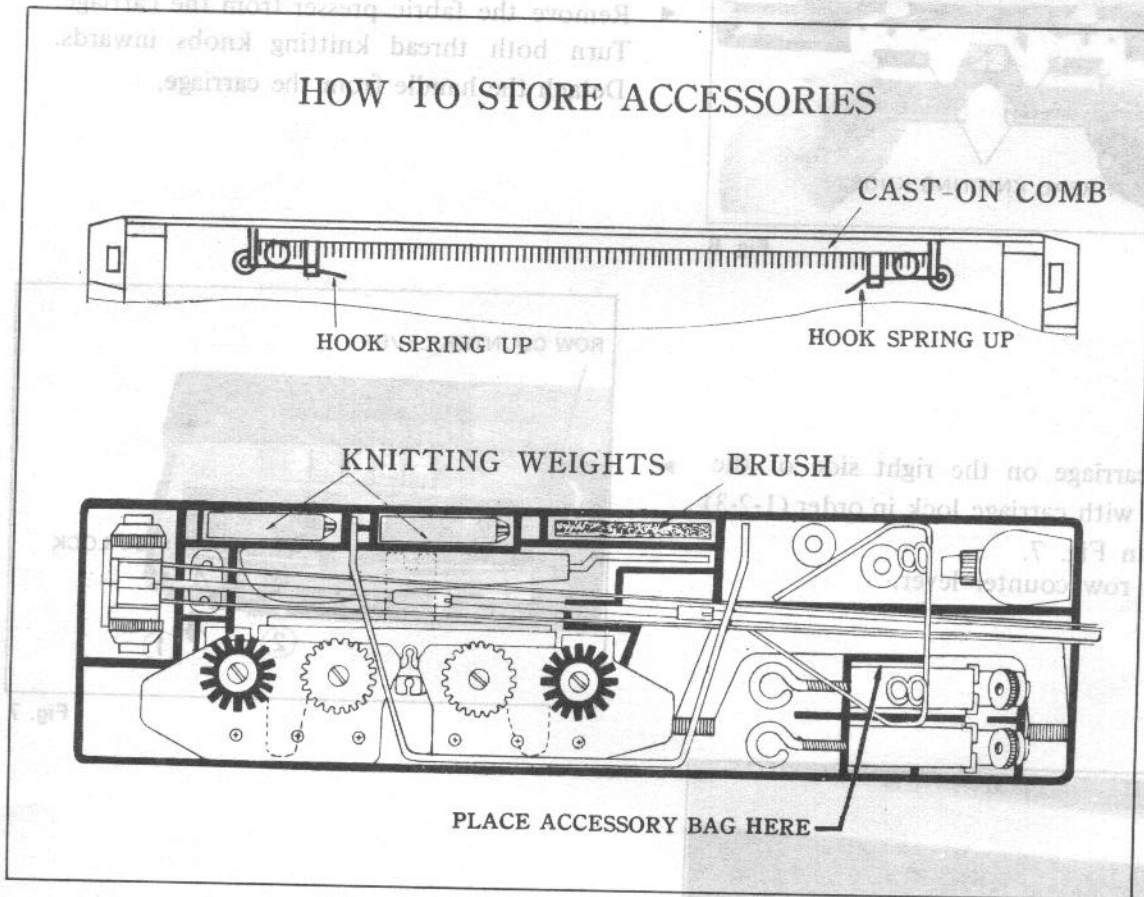

Fig. 10

Put the accessories such as fabric presser, clamps into the accessory box as shown in Fig. 10.

HOW TO KEEP THE MACHINE

Set the accessory box on the needle bed by inserting the projection on the underside of the accessory box into the setting hole on the left end of the needle bed.

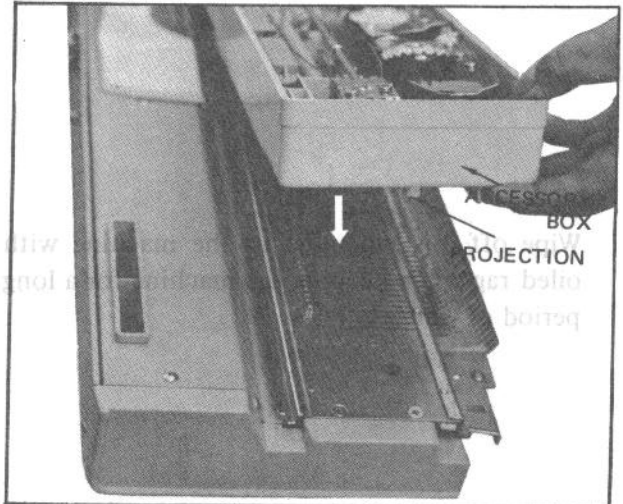
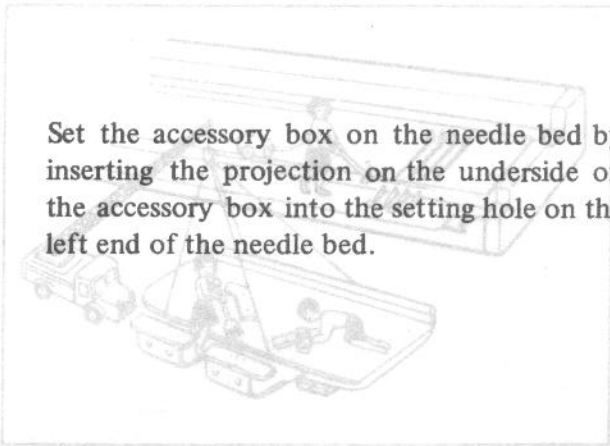

Fig. 11

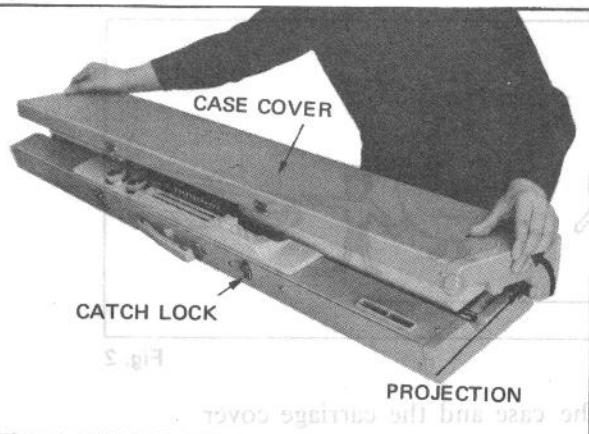
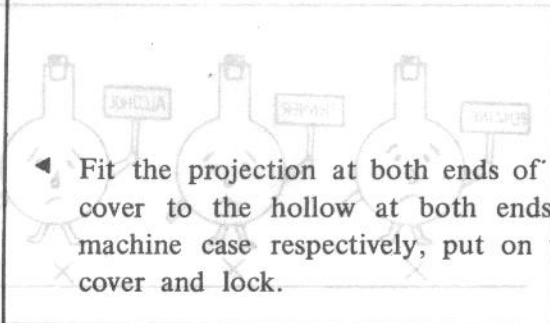

Fig. 12

Fit the projection at both ends of the case cover to the hollow at both ends of the machine case respectively, put on the case cover and lock.



When the machine is used again after a long period of storing, wipe off the stored oil and apply fresh oil to the butt of the latch needles, various cam surfaces of the carriage and the front and back rail surfaces of the needle bed.

When beginning to knit, first knit all stitches for 20-30 rows with old yarn.

Store the machine in a dry, cool place.

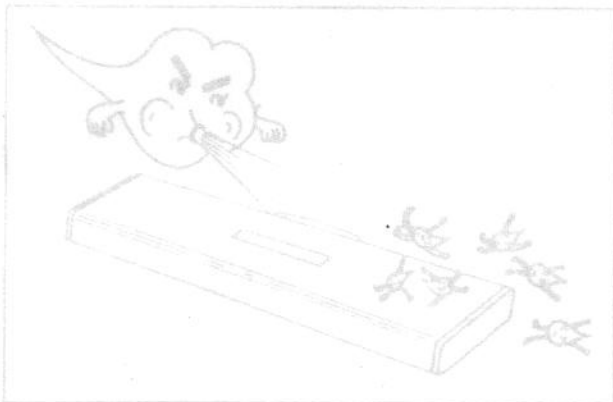
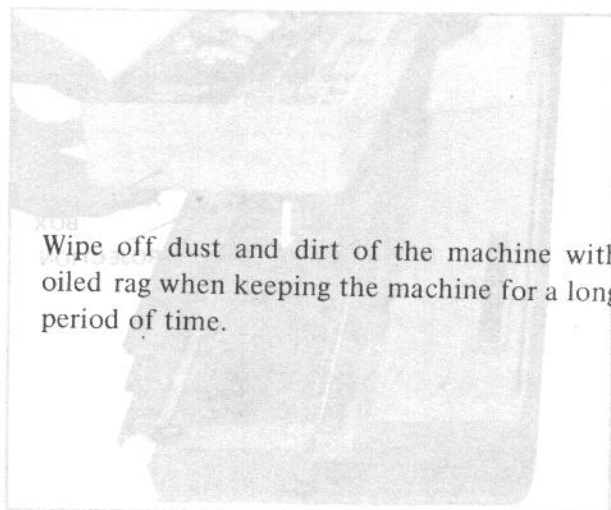

Fig. 3

HOW TO KEEP THE MACHINE



Wipe off dust and dirt of the machine with oiled rag when keeping the machine for a long period of time.

Fig. 11

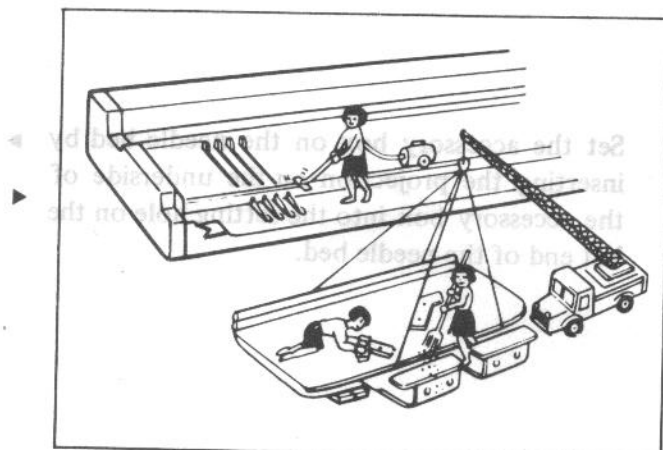

Fig. 1

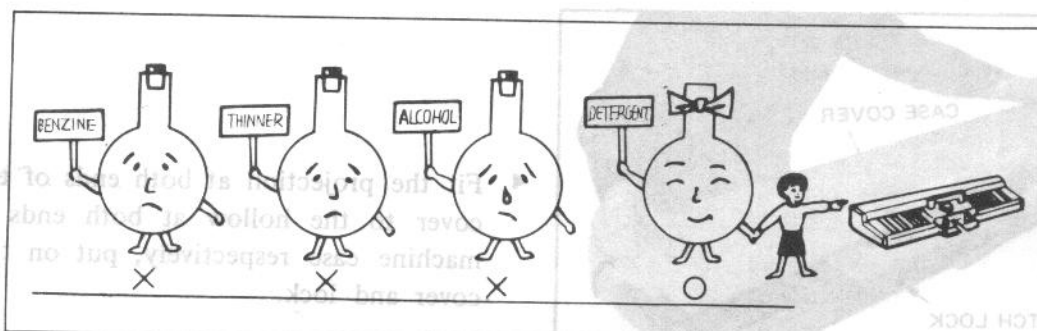

Fig. 2

Apply oil carefully to the metallic parts. Clean the case and the carriage cover with a cloth soaked with neutral detergent.

Note: Never use thinner, benzine, alcohol, gasoline, etc.

Store the machine in a dry, cool place.

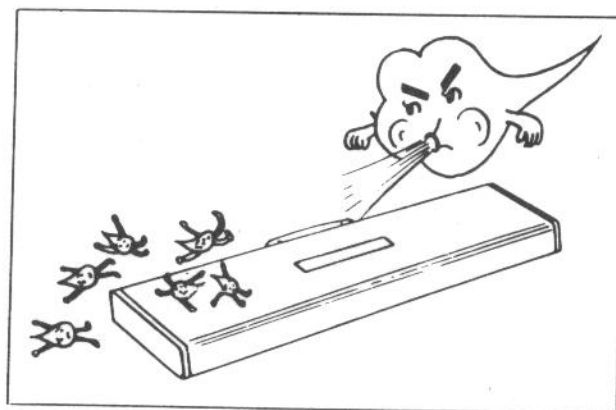

Fig. 3











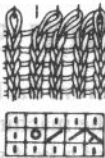



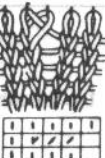

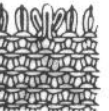

When the machine is used again after a long period of storing, wipe off the coated oil and apply fresh oil to the butt of the latch needles, various cam surfaces of the carriage and the front and back rail surfaces of the needle bed.

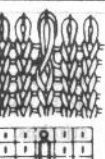
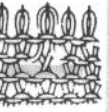
When beginning to knit, first knit all stitches for 20 – 30 rows with old wool yarn.

STANDARD STITCH SIGNS

The signs shown here are as the material would be seen from the knit side. This is because both purl and knit stitches are shown as knit stitch signs on the machine. Remember, though in an actual practice a purl stitch is in the opposite direction of a knit stitch.

	Knit 3 stitches together, stitch of the left being in front:		Make the middle needle vacant by transferring the stitch onto the left temporarily, remove a stitch from the right onto the vacant needle, also the two stitches from the left needle.	
	Knit 3 stitches together, stitch of the right being in front:		Do the same thing as above reversely.	
	Knit 3 stitches together, middle stitch being in front:		Put each stitch from both sides on the middle needle.	
	Knit 2 stitches together, right stitch on left:		Put a right stitch on a left stitch or first, remove a right stitch to its next right stitch and on a vacant needle, put a left stitch on which put back the stitch firstly removed to the right side.	
	Knit 2 stitches together, left stitch on right:		Do reversely against the above way of symbol.	
	Purl stitch:		With a tappet or a crochet needle you can undo knit stitches and change them into purl stitches.	
	Knit stitch or plain stitch:		Put yarn over machine needles in an ordinary way and knit.	
	Cross stitch, left side loop over the right:		Transferring one stitch onto the left temporarily slip a stitch from the right onto the vacant needle: remove the former onto the vacant needle on the right.	
	Cross stitch, right side loop over the left:		The same thing as the other done reversely.	
	Transfer stitches toward the left:		After knitting two stitches together for a pattern some stitches are to be transferred one after another and this symbol says to do it leftward.	

/	Transfer stitches toward the right:		Do the same thing as above reversely.	
Y	Increase one stitch at left side:		Make one needle vacant, pick up a right stitch of the preceding row as a new stitch for the vacant needle.	
Y	Increase on stitch at right side:		Make one needle vacant, pick up a left side stitch of the preceding row as a new stitch for the vacant needle.	
O	Hole:		Make a needle vacant and knit one row.	
3	Missing extended loop:		The loop in the bottom row is brought to the top row, without making any stitch rows in between.	
ω	Wrapping stitch:		This is the way how to cast on or to increase stitches.	
8	Floating loop:		The loop in the bottom row is tucked and the yarn is knit across the front of the top row.	
Q	Twist stitch:		Taking a stitch off the needle, twist it once and put it back on the previous needle.	
V	Undone stitch seen sideway:		When undone stitch is pulled up a sideway stitch should be seen on stockinette side.	
U	Pull up stitch:		Undo a stitch on any rows marked with this symbol; pull up all the undone stitches and place them on one needle.	
V	Increase in cast on comb:		Stitches marked with this sign should be undone and the lowest loop only should be pulled up. This figure shows as one row is undone.	



AISIN SEIKI CO., LTD