

A woman wearing a patterned headscarf and a long, patterned dress stands against a textured, brown wall. She is looking directly at the camera with a neutral expression. The background is dark on the right side.

# **INSTRUCTION MANUAL**

**TOYOTA KS 787**

**TOYOTA**



## CONTENTS

### I HOW TO USE KNITTING MACHINE

<b>NAMES AND FUNCTION</b>	
MACHINE BODY .....	1
MAIN CARRIAGE .....	2
LACE CARRIAGE .....	3
ACCESSORIES .....	4
<b>1. SETTING UP THE MACHINE</b> .....	<b>5</b>
<b>2. PACKING YOUR MACHINE</b> .....	<b>8</b>
<b>3. BEFORE START KNITTING</b>	
PREPARATION OF YARNS .....	10
GENERAL GUIDE TO TENSION DIALS AND YARNS	
THREADING .....	11
<b>4. CASTING-ON</b> .....	<b>12</b>
<b>5. PUNCH CARD KNITTING</b>	
GENERAL GUIDE TO PUNCH CARD	
SETTING CARD .....	14
FAIR ISLE KNITTING .....	15
TUCK STITCH KNITTING .....	16
TUCK STITCH KNITTING IN COLOUR .....	17
TUCK PATTERN KNITTING (EX. MOSS STITCH) .....	18
SLIP LOOP KNITTING .....	19
WEAVING (THREAD KNITTING) .....	20
LACE KNITTING .....	21
<b>6. AUTO MOTIF KNITTING</b> .....	<b>23</b>
NEAT FINISH METHOD FOR FAIR ISLE KNITTING .....	26
<b>7. YOUR OWN ORIGINAL STITCHES</b>	
MANUAL SELECTION BUTTONS AND ZIGZAG DIAL	
(PATTERN A) .....	29
(PATTERN B) .....	30
<b>8. PARTIAL KNITTING (HOLDING POSITION) OF PATTERN KNITTING</b>	
PARTIAL KNITTINGS OF FAIR ISLE STITCH, SLIP LOOP STITCH, WEAVING STITCH, AND TUCK PATTERN STITCH .....	31
PARTIAL KNITTING OF TUCK STITCH .....	32
PARTIAL KNITTING OF LACE STITCH .....	33
<b>9. FUNDAMENTAL HINTS</b>	
PLAIN DOUBLED HEM .....	34
PICOT HEM .....	35
CABLE KNITTING .....	36
OPEN STITCH WORK .....	37

1 X 1 RIBBING .....	38
CORDING .....	39

### 10. HOW TO FIX THE MACHINE

CARRIAGE JAMMING IN PLAIN KNITTING .....	40
CARRIAGE JAMMING IN PUNCH CARD KNITTING .....	41
CORRECTING STITCHES AFTER ADVANCING THE PUNCH CARD SETTING CARRIAGE ONTO ADVANCING THE PUNCH CARD ..	42
WHEN THE LACE CARRIAGE GETS STUCK WHILE KNITTING ...	43
REPLACING THE NEEDLE .....	44
DROPPED ONE STITCH .....	45
DROPPED A FEW ROWS .....	46

### 11. PROPER CARE OF THE MACHINE

DUSTING AND OILING .....	47
--------------------------	----

## II KNITTING A SWEATER LADY'S PULLOVER

MEASUREMENTS .....	48
TENSION GAUGE .....	49
WELT (MOCK RIB) .....	50
BACK	
ARM HOLE .....	51
CASTING-OFF .....	52
DECREASING STS. .....	53
SHAPING SHOULDER (METHOD I)	
(METHOD II—PARTIAL KNITTING) ..	54
SHAPING NECK & SHOULDER (METHOD I) .....	55
(METHOD II) .....	56
FRONT	
WELT, BODY, & ARM HOLE .....	57
SHAPING R-NECK & SHOULDER (METHOD I) .....	58
(METHOD II) .....	59
SLEEVE	
BAND & SHAPING SLEEVE	
INCREASING ST .....	60
SHAPING TOP SLEEVE	
INCREASING MANY STS .....	61
TO MAKE UP .....	62
NECK BAND .....	62

**MAIN CARRIAGE**

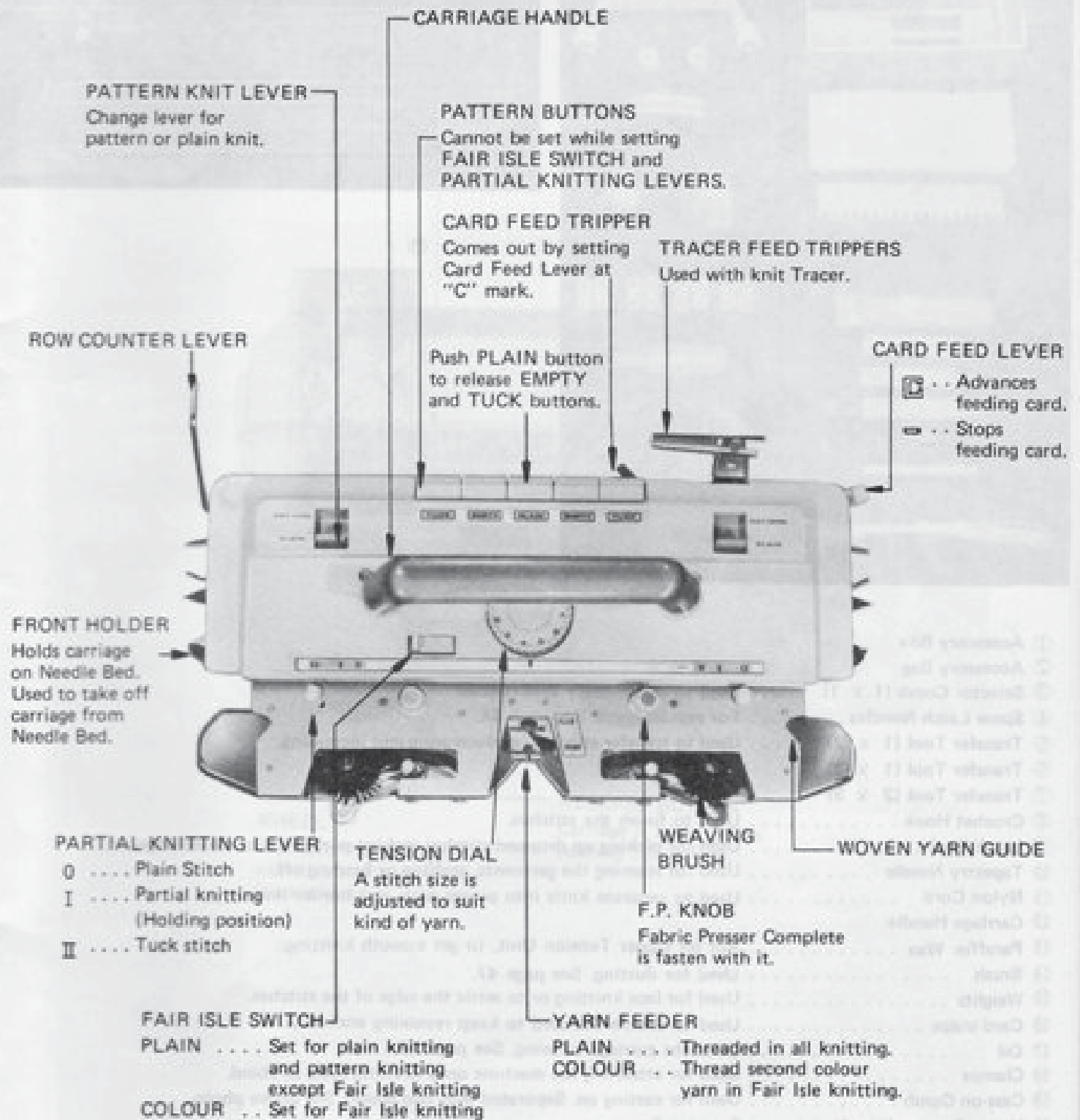

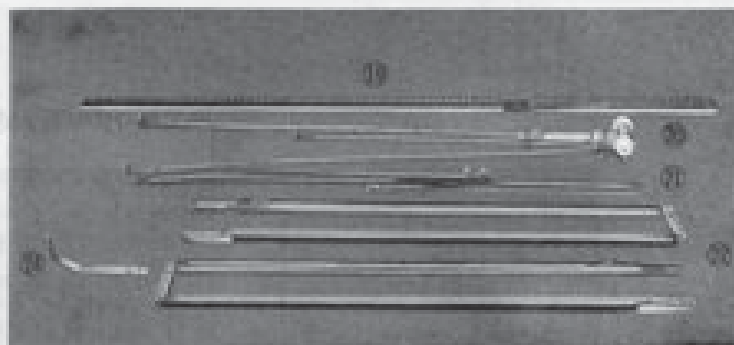
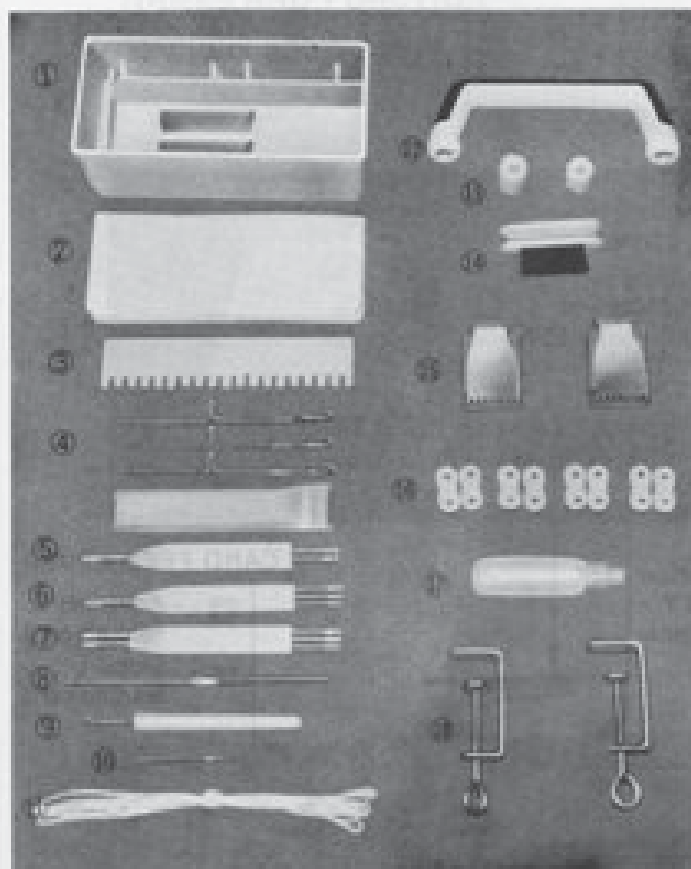

- ① Accessory Box
- ② Accessory Bag
- ③ Selector Comb (1 x 1) . . . . . Used to select every 2nd needle.
- ④ Spare Latch Needles . . . . . For replacement. See page 44.
- ⑤ Transfer Tool (1 x 2) . . . . . Used to transfer stitches for decreasing and increasing.
- ⑥ Transfer Tool (1 x 3)
- ⑦ Transfer Tool (2 x 3)
- ⑧ Crochet Hook . . . . . Used to finish the stitches.
- ⑨ Latch Tool . . . . . Used for picking up dropped stitches making purl stitch or closed edge.
- ⑩ Tapestry Needle . . . . . Used for seaming the garments, grafting or binding off.
- ⑪ Nylon Cord . . . . . Used to separate knits into pieces such as a border line.
- ⑫ Carriage Handle
- ⑬ Paraffin Wax . . . . . Put on Upper Tension Unit, to get smooth knitting.
- ⑭ Brush . . . . . Used for dusting. See page 47.
- ⑮ Weights . . . . . Used for lace knitting or to settle the edge of the stitches.
- ⑯ Card snaps . . . . . Used to enable the card to keep revolving endlessly.
- ⑰ Oil . . . . . Smooths carriage running. See page 47.
- ⑱ Clamps . . . . . Used for attaching the machine onto knitting table or stand.
- ⑲ Cast-on Comb . . . . . Used for casting on. Separated into two pieces. See above photo.
- ⑳ Upper Tension Wire Unit . . . . . See page 6.
- ㉑ Upper Tension Rod . . . . . See page 6.
- ㉒ Extension Rails . . . . . Inserted at both ends of the machine. Used for lace knitting and extra large garments.
- ㉓ Basic Punch Cards . . . . . Used for automatic pattern knitting. (20pcs.)
- ㉔ Carriage Lock . . . . . Secures carriage to eliminate damage during transport.

LACE CARRIAGE

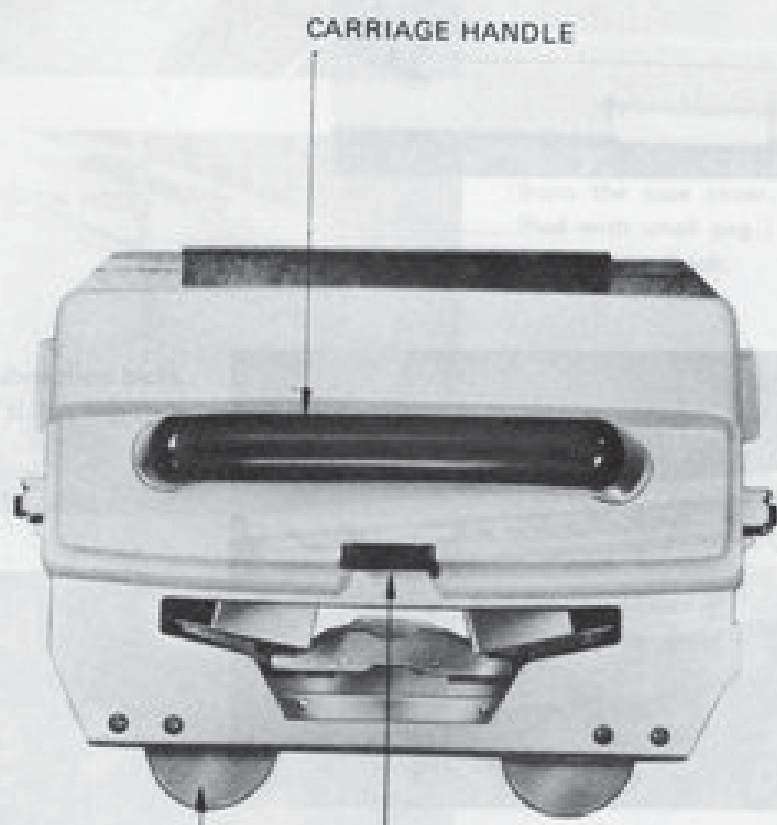

CARRIAGE HANDLE

WHEEL

The needle crosses over with this and a stitch is transferred.

RELEASE BUTTON

Carriage is taken off by pushing this button.

# 1. SETTING UP THE MACHINE

FACE CARTRIDGE

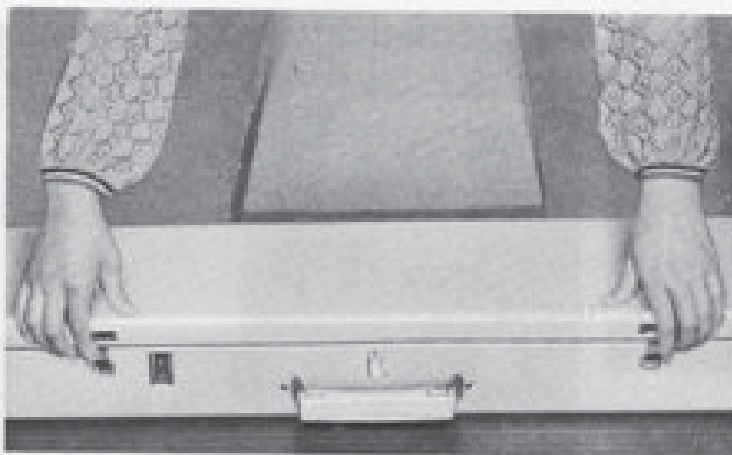

Place the case on the table with the handle away from you. Unfasten both buckles.

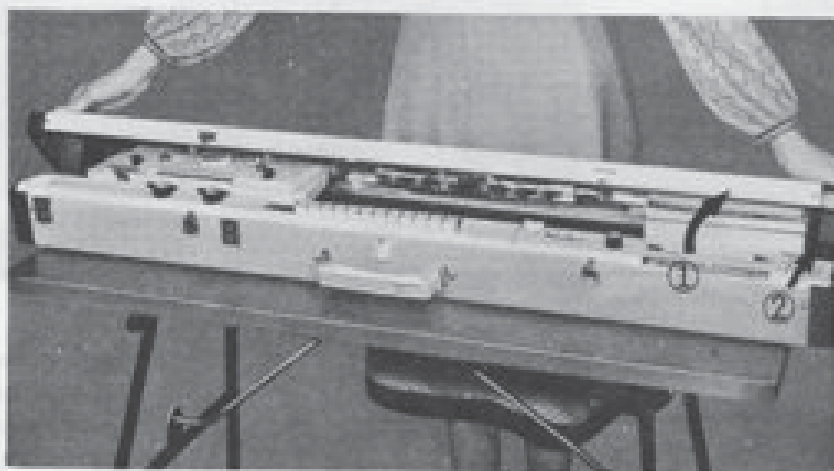

Hold both ends of the case cover. Lift and pull it towards you.

Take out accessories referring to Storage Instructions.

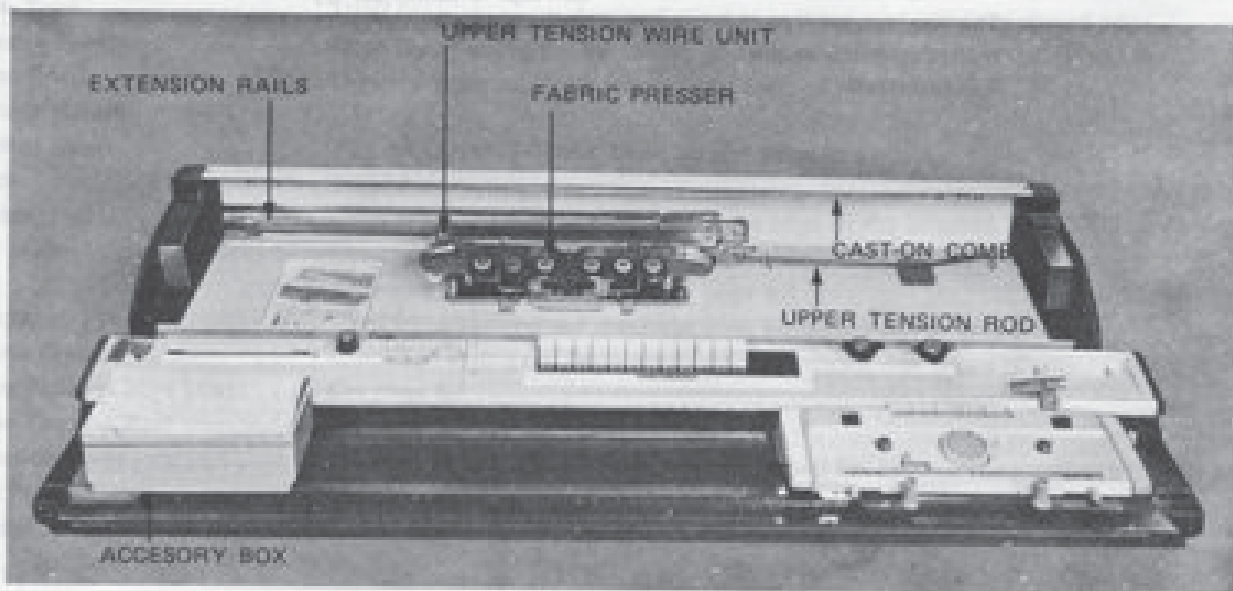

## 2. PACKING YOUR MACHINE

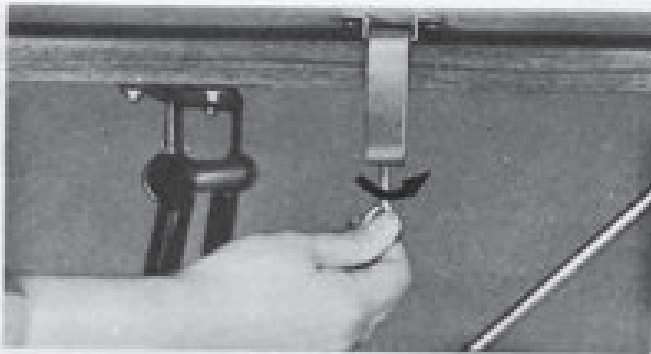

Insert the clamps into slits underneath the machine.

Secure the machine on the table.

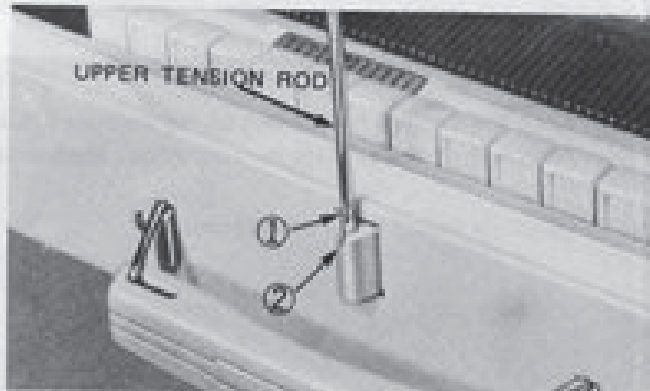

Take out the Upper Tension Wire and the rod from the case cover. Insert the Upper Tension Rod with small peg ① downwards into the slit ② at the centerback.

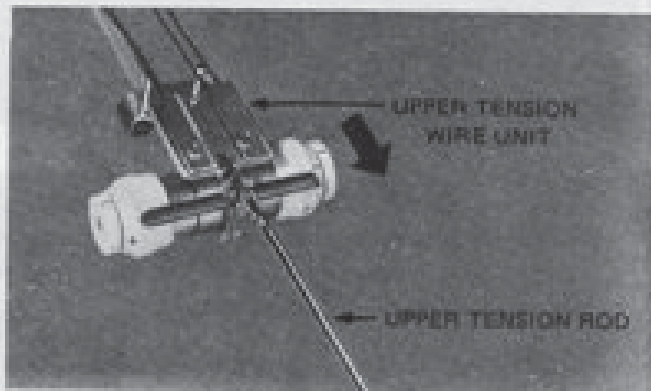

Put the Upper Tension Wire Unit on the top of the Rod.

Ensure the tip on the rod fits firmly into the notch at the back of the Upper Tension Wire Unit.

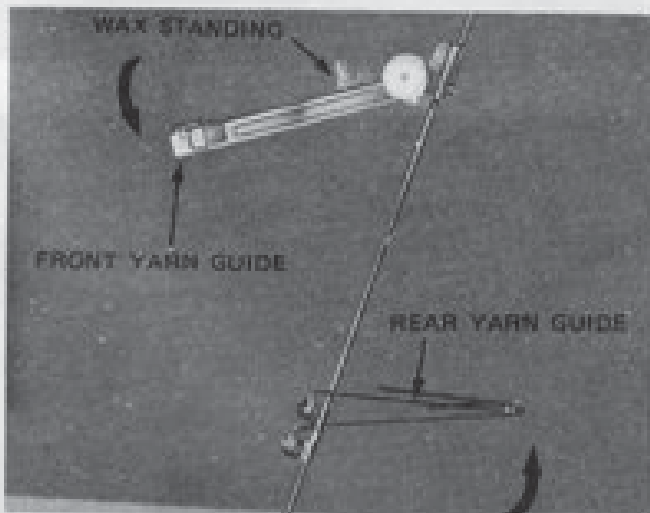

Pull out the front yarn guide and the rear yarn guide as shown by arrow marks.

(Paraffin wax can be put it on the wax standing.)

## 1. SETTING UP THE MACHINE

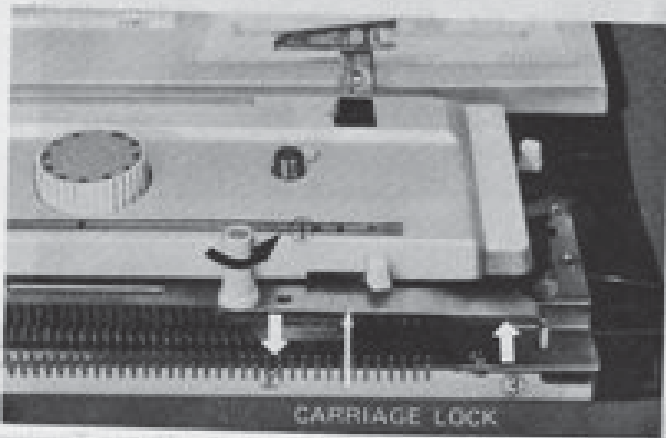

Remove the carriage lock from the carriage by loosening F.P. knobs ① and follow the arrows ② ③.

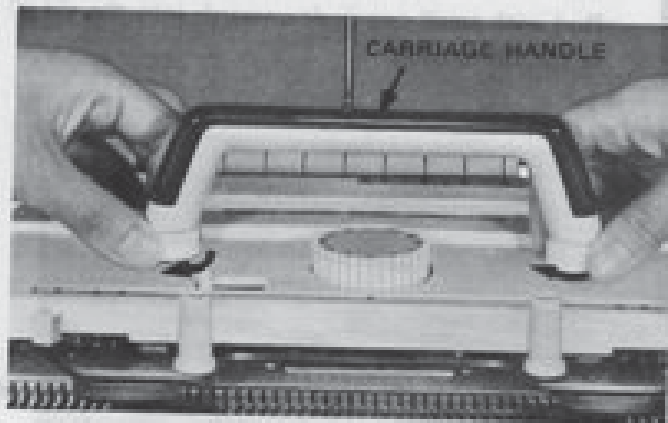

Take the carriage handle out of the accessory box. Attach it to the carriage turning screws clockwise.

Carefully fasten them simultaneously.

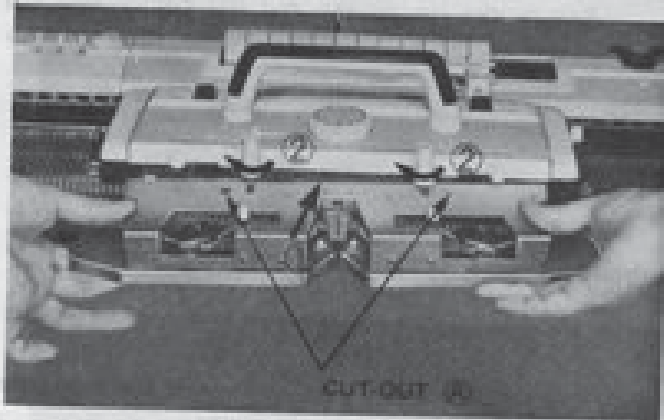

Take out Fabric Presser from case cover.

Loosen both F.P. knobs (counter clockwise). Attach Fabric Presser to the carriage ① matching both sides of cut-outs ② with the small pegs on the carriage and pull it towards you. Tighten F.P. knobs firmly turning it clockwise ②.

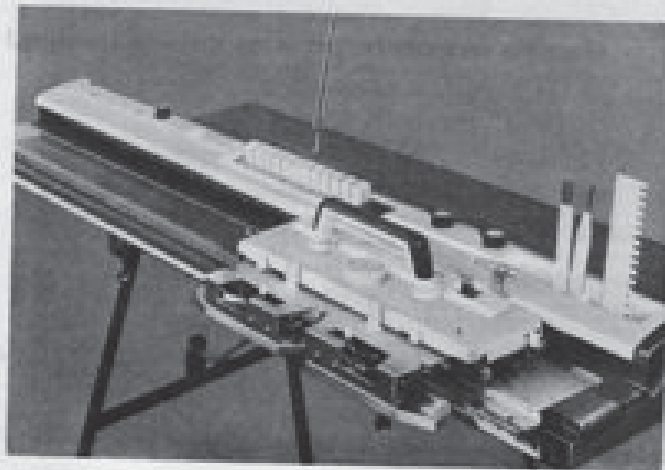

Your machine is set up and ready for use.



## 2. PACKING YOUR MACHINE

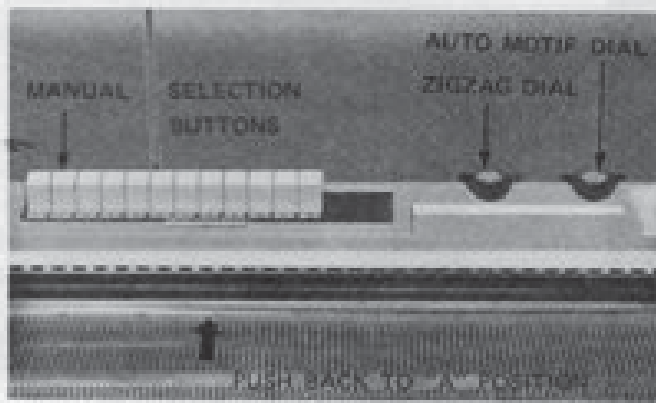

\* Do not operate the Card Feed Dial, Manual Selection Buttons or Zigzag Dial without pushing the Pre-Set Clutch Lever.

Set Zigzag Dial at "1" and Auto Motif Dial at "0".

Release the Manual Selection Buttons by pulling upward when they are on (see page 30). Push all the needles back to "A" position.

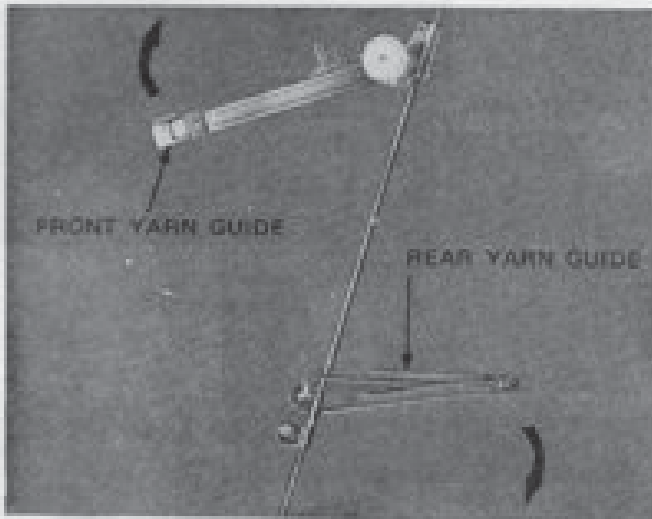

Fold the rear yarn guide and the front yarn guide as shown by the arrows.

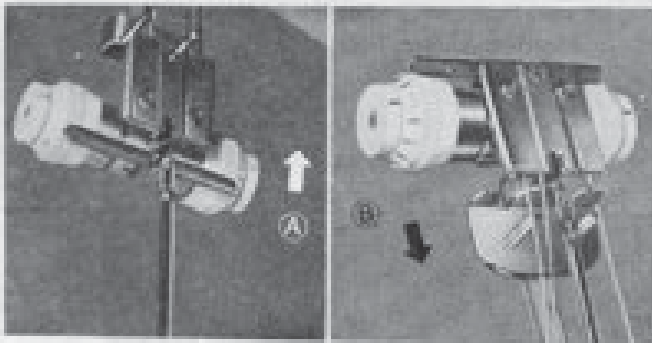

Pull out Tension Unit following the direction of arrow A. Hold it upside down and slide it onto the rod B. Fit them at the back of the case cover referring to Storage Instruction.

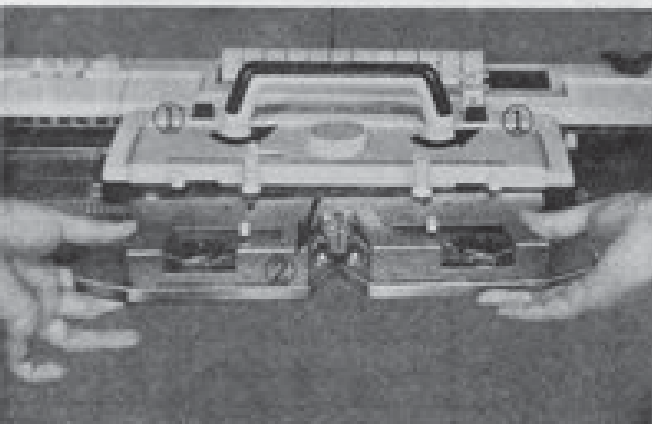

Remove carriage handle ① and fabric presser ②.

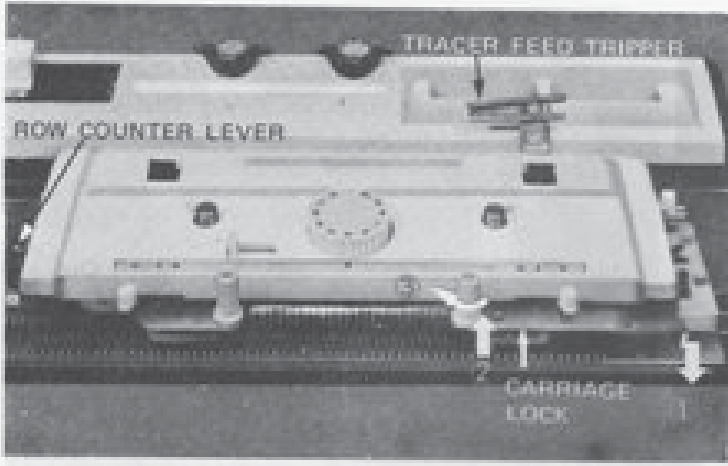

Put main carriage at the right end of the needle bed and secure it with the carriage lock. Push down row counter lever and tracer feed tripper following the direction of the arrows.

The main carriage must be secured with the carriage lock to prevent damage during transportation.

Remove both clamps underneath of machine.

Make your machine stationary thus:  
Store accessories in the accessory box and at the back of the case cover.  
(see Storage Instruction)

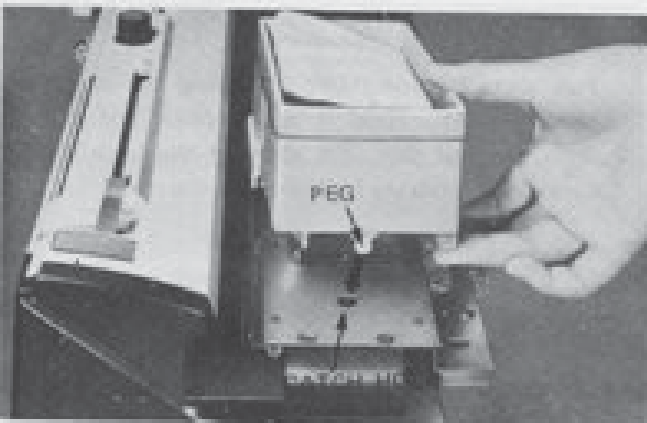
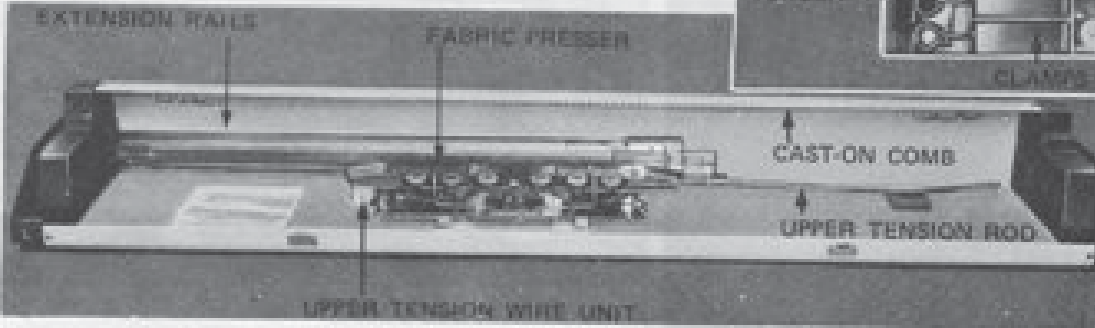

Put accessory box at the left end. Be sure to match peg at the bottom of the accessory box with the catch hole.



Put the case cover over the main bed and lock it. Be sure the projections on the case cover end fit snugly into the front dents at the ends of the main bed.



### 3. BEFORE START KNITTING

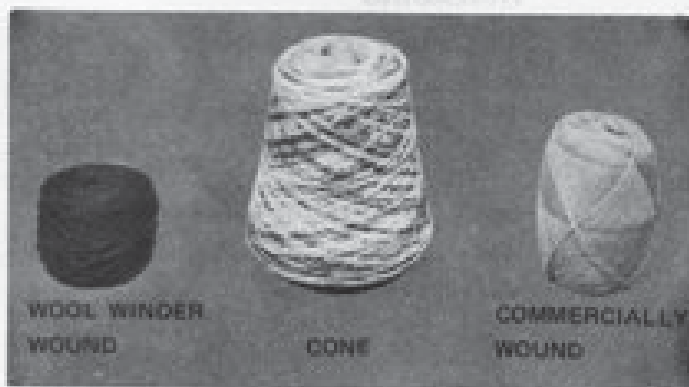

#### PREPARATION OF YARNS

Prepare cone or machine (Wool winder) wound ball for smooth knitting.

- Never knit from a bank of yarn or a band wound ball.

The wool winder is very useful for winding yarn or for undoing.

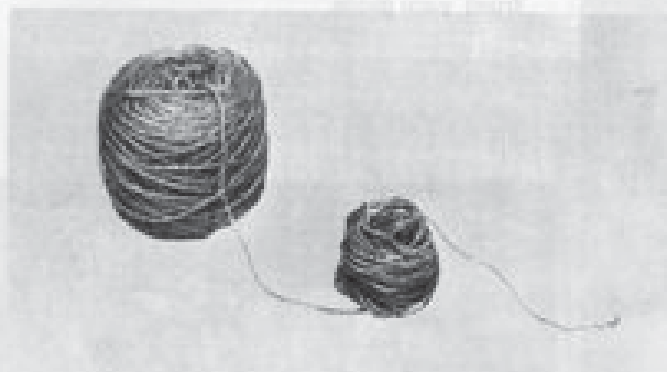

When the yarn does not come smoothly from center, it is recommended that you use a Knitting Spray or pull out a handful of yarn from the center of the ball.

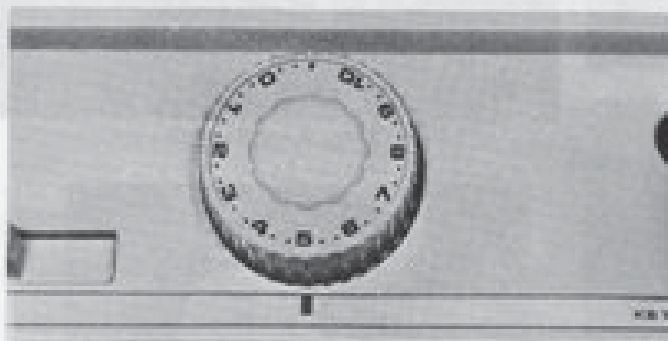

#### GENERAL GUIDE TO TENSION DIALS AND YARNS

Match the appropriate number on Tension Dial to the "■" mark at center.

The size of the stitch will become bigger by turning the dial to a bigger number and vice versa.

(Names of yarn will vary in each country.)

- Use short wire with Upper Tension Wire when thick yarn (more than 6 ply) is used.

Kind of yarn (In live size)	Cotton	Fine	Soft strand 2ply	Fine medium 3ply	Medium 4ply	Thick 2ply	Thick 3ply	Crepe 5/4ply	6ply	Crepe 8ply	Crepe 12ply	Boucle	Mohair	Tweed
Tension Dial	2~4	1~3	1~3	2~4	3~5	5~6	4~5	5~7	6~8	8~9	8~10	4~5	4~5	4~5
Lace Knitting	4~5	3~4	3~4	4~5	5~6	5~6	5~6	6~7	(7~8)	-	-	4~5	4~5	-
Mock Rib	Use 2 or more numbers lower than normal tension level.													

PREPARATION OF YARN

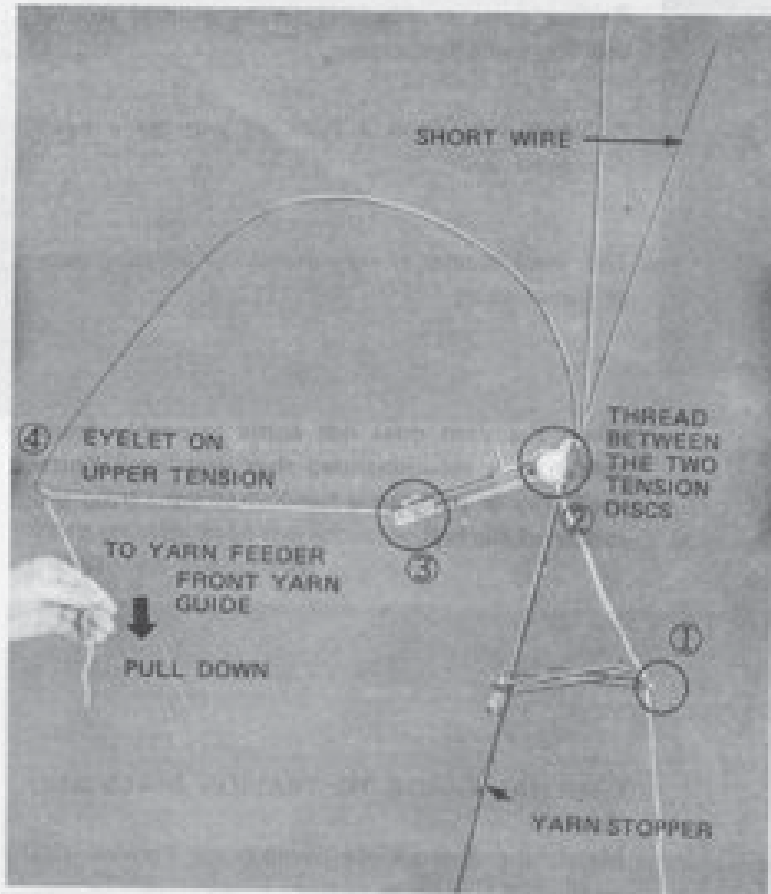

THREADING

Thread yarn following steps

① ② ③ ④.

The end can be hooked at yarn stopper.

With your right hand, adjust the U.T. dial while you are pulling the yarn down with your left hand.

Continue adjusting dial until the eyelet on the wire is on the same level as the front yarn guide.

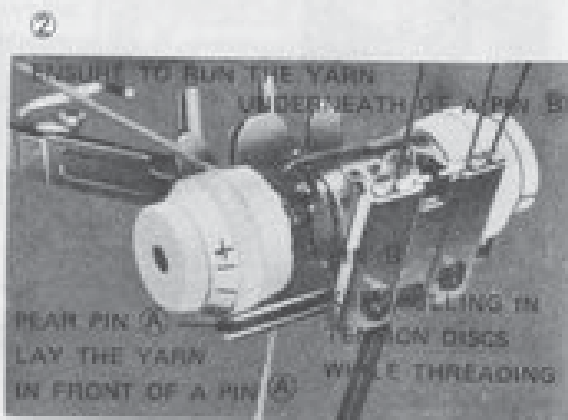

When the upper tension dial is adjusted, the yarn will be pulled out.

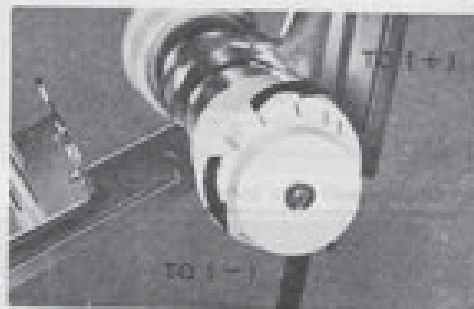
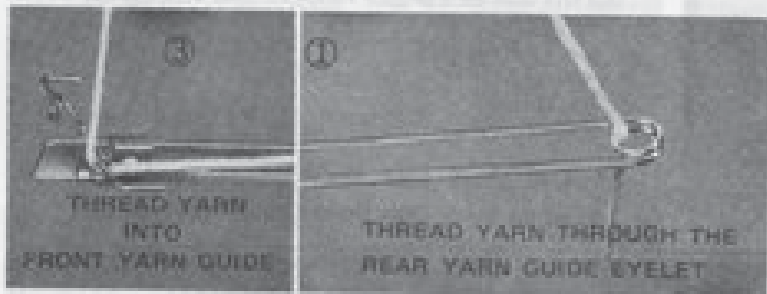

For fine yarn ..... Turn to (+) direction.  
For thick yarn ..... Turn to (-) direction.

For smooth running, we recommend the use of paraffin wax regardless of the kind of yarn.

To prevent yarns from being tangled, put balls of yarn far apart each other.

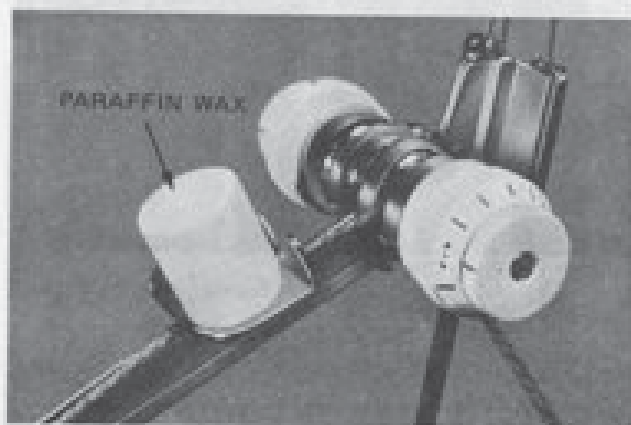

#### 4. CASTING-ON (Closed - Plain Edge)

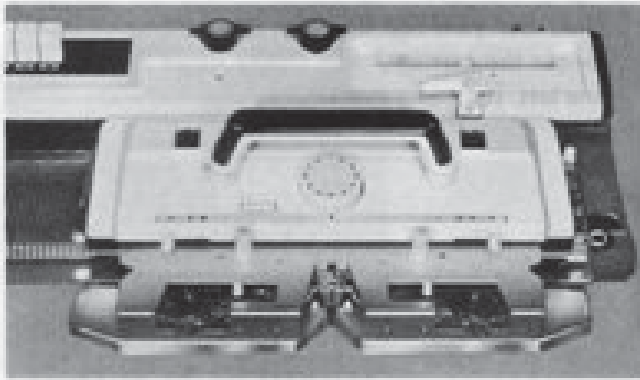

Feeding hole

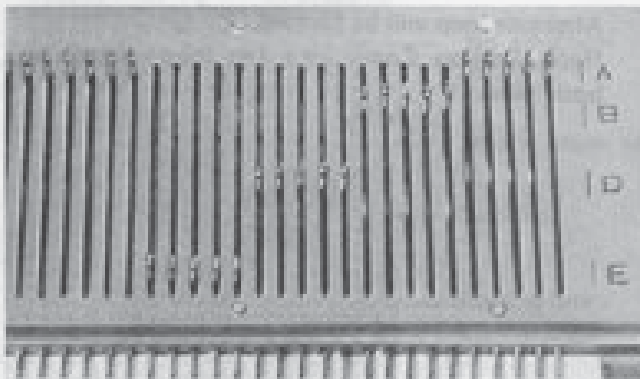

Close-up of needles

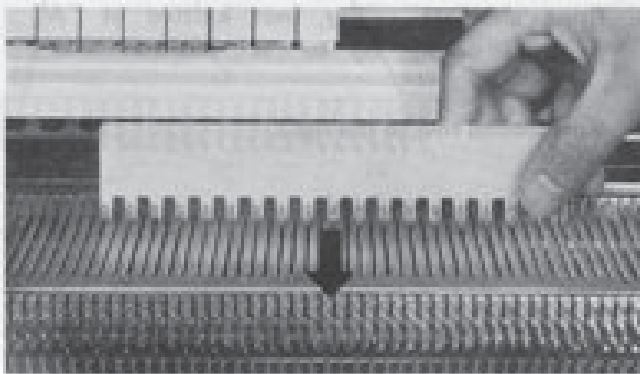

Slide card between needles and push down to lock needles in position.

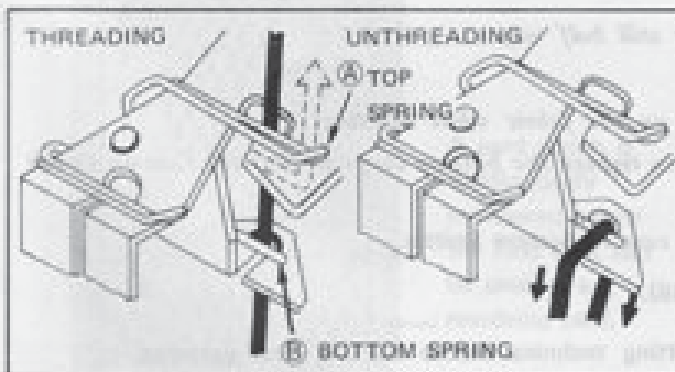

#### GENERAL GUIDE TO PUNCH CARD

Place main carriage at the right.

Be sure the main carriage is set at neutral (No buttons in).

Set weaving brushes at "□" mark.  
(If row counter is required, set it.)

A,B,D,E. at the both ends of the needle bed represent the position of the needle butt.

A position . . . . . Non working position.

B position . . . . . Working position.

D position . . . . . Selected needle position.

E position . . . . . For partial knitting  
(holding position or short row).

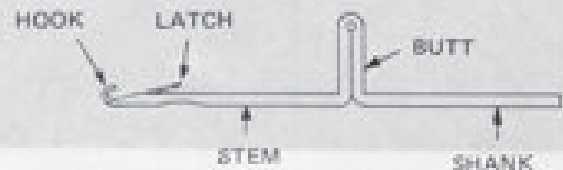

Bring the required number of alternate needles from "A" (non working) position to "B" (knitting) position.

#### THREADING YARN INTO YARN FEEDER.

Hold the yarn with both hands and slide it into top spring (A), then push bottom half into bottom spring (B) making sure that the spring clicks.

#### REMOVING YARN.

Remove yarn from top spring, then pull it towards you.

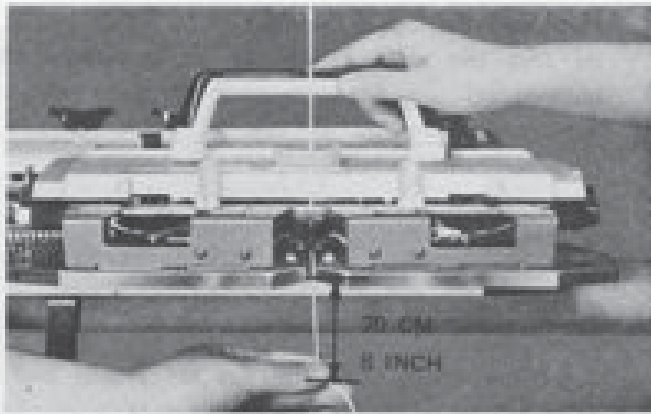

Hold the yarn end down at about 20cm (8 inch) below the carriage, then slowly move carriage to the left. (knit one row.)

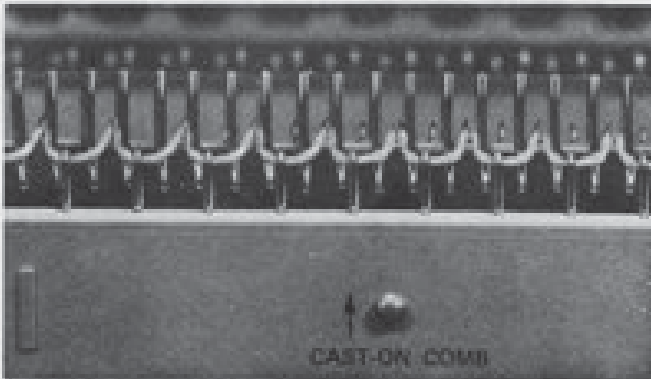

Alternate loop will be formed.  
Hook Cast-on Comb into the loops balancing both sides.

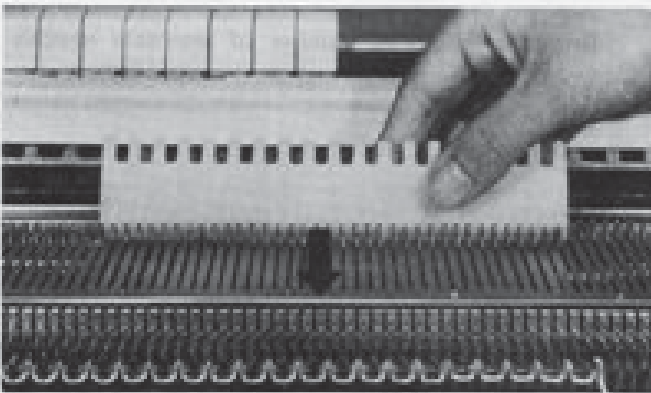

Bring alternate empty (not knitted at "A" position) needles up to "B" position.

Knit second row to the right.

Casting-on is completed.

- \* Ensure carriage passes the last knitted needle by approximately 5 cm then gradually change the direction.
- \* Be sure not to force the carriage back while still half way.
- \* If carriage becomes stuck, see page 40.
- \* It will be convenient to keep Cast-on Comb on the fabric while knitting.
- \* After knitting 2 or 3 rows, pull the yarn end to tighten the bottom loops so that the Cast-on Comb won't drop.
- \* Hang weights on the both ends of the fabric in case of pattern knitting.

You are now ready to knit your sweater (see page 48).

It is recommended to practice some basic knitting technics before starting first garment. For example, a welt or band using 1 x 1 rib (for ribber user) or mock rib, decreasing stitches, increasing stitches, round neck, and casting off. (Refer to pages 38, 51, 53, 58 and 60.

## 5. PUNCH CARD KNOTTING

### GENERAL GUIDE TO PUNCH CARD

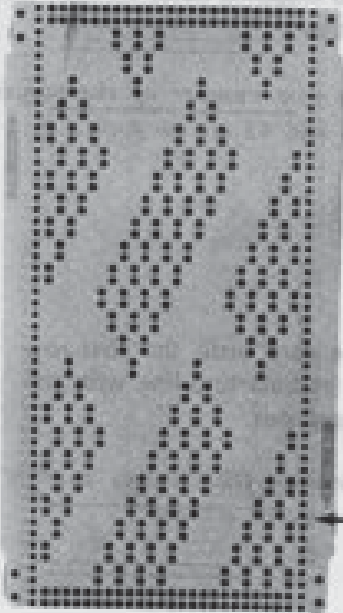
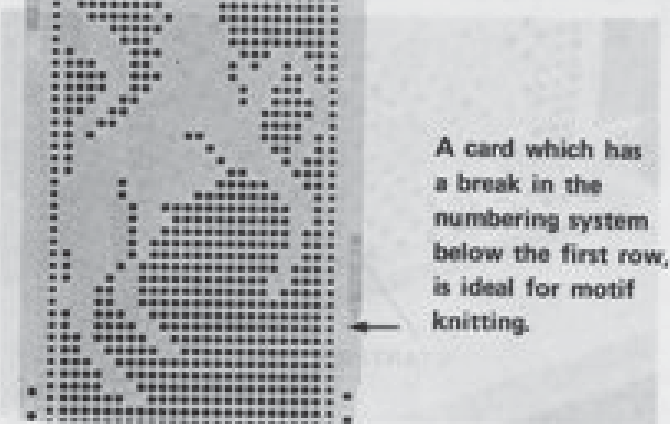
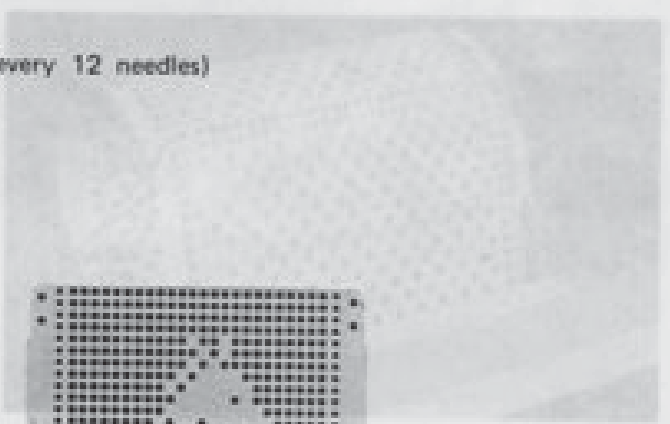
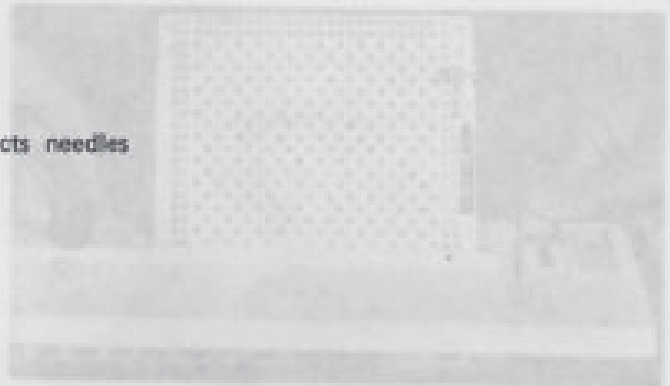
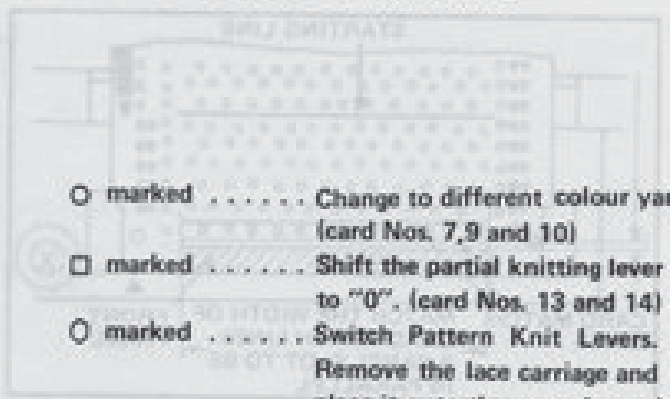
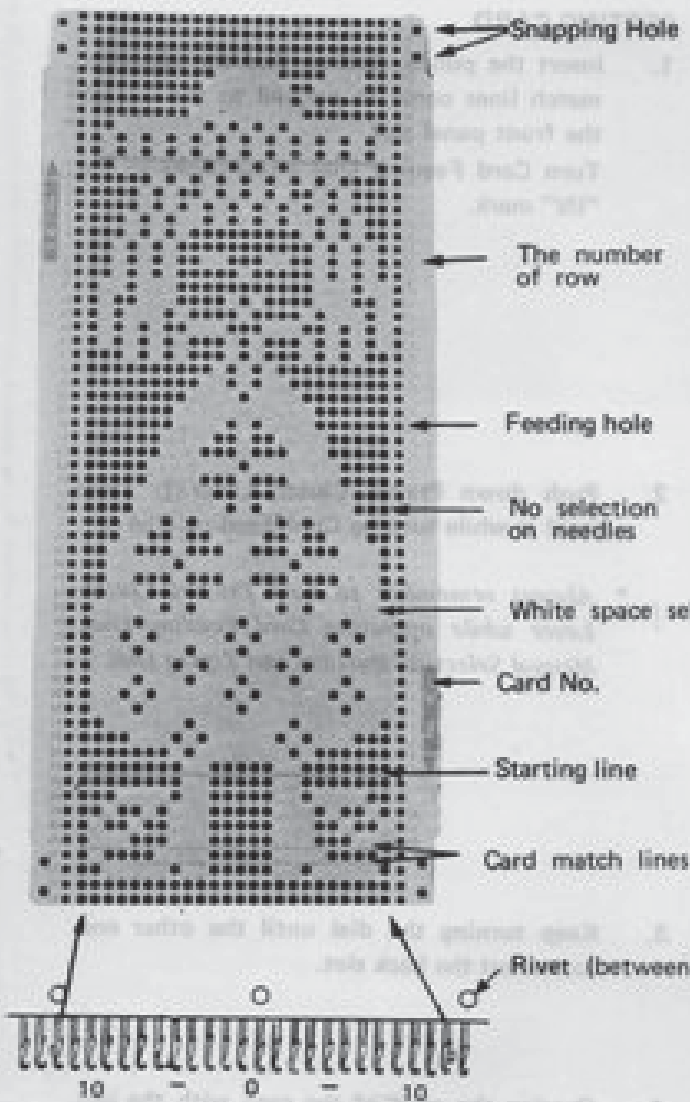

A card which is continuously numbered below the first row, can be used as a revolving card.

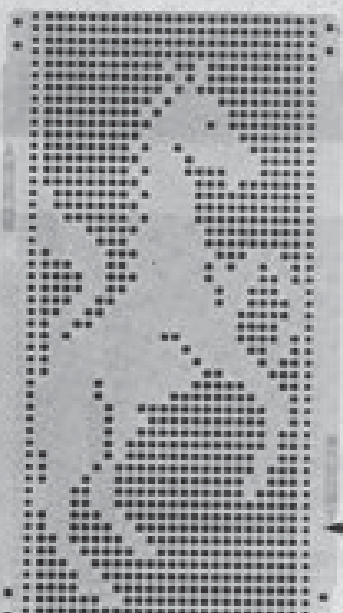

A card which has a break in the numbering system below the first row, is ideal for motif knitting.

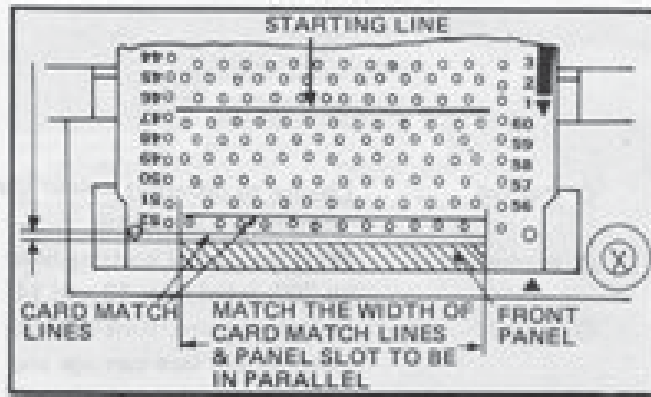

(See also page 1)

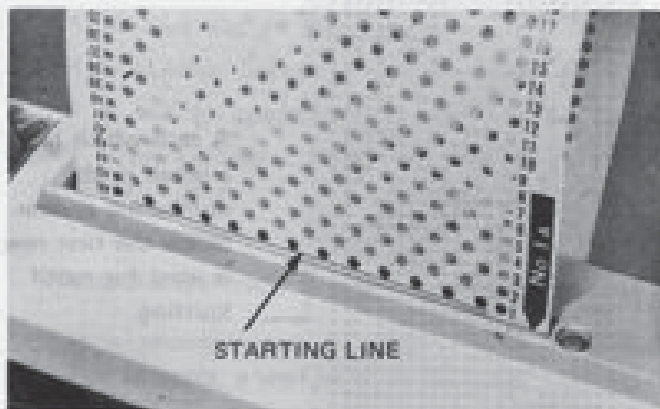
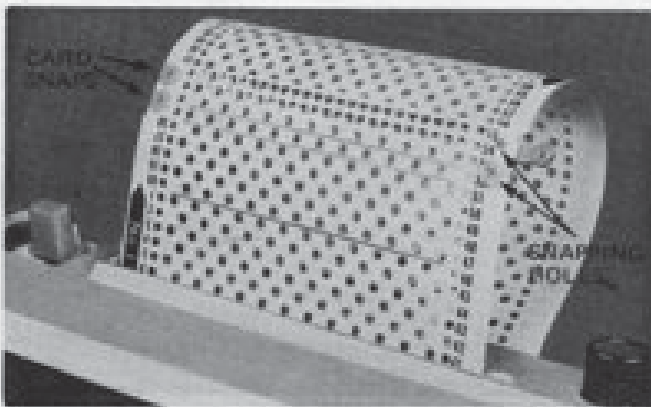
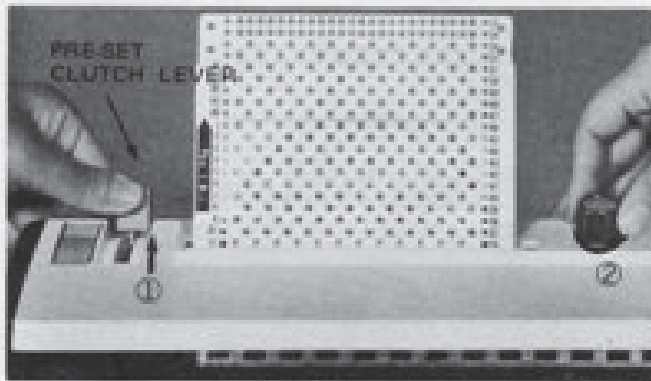

**SETTING CARD**

1. Insert the punch card so that the red card match lines come to parallel to the top of the front panel slot.  
Turn Card Feeding Dial a few clicks to the "IN" mark.

2. Push down Pre-set Clutch Lever ① and hold it while turning Card Feeding Dial ②.

\* Always remember to hold Pre-Set Clutch Lever while operating Card Feeding Dial, Manual Selection Buttons and Zigzag Dial.

3. Keep turning the dial until the other end comes out the back slot.

4. Overlap the ends of the card with the last row on top.  
Match the two snapping holes on each side and snap together.

\* Make sure the row number of the punch card either 55 and 43 are on top.

5. Turn back the card until the first row and align the red starting line with the top of the panel slot.

\* Turn Card Feeding Dial always to "IN" direction when snaps are on.



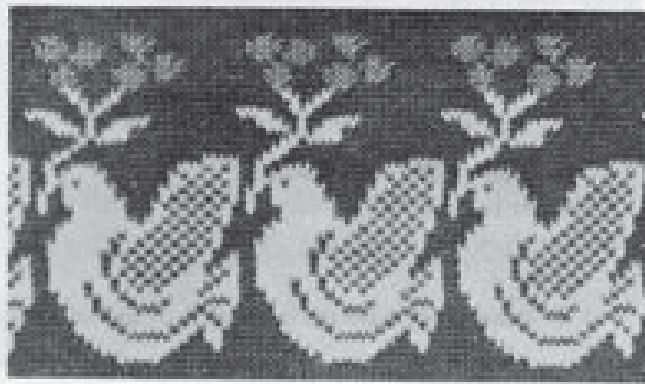

**FAIR ISLE KNITTING**

(Two colour yarns will be knitted at a time.)

Assume casting-on is finished (refer to page 12).

Hook the short wire onto Upper Tension Wire where second colour yarn is threaded.

Turn Upper Tension Dial to (+) direction.

\* Make sure Auto-motif Dial is on Zero.

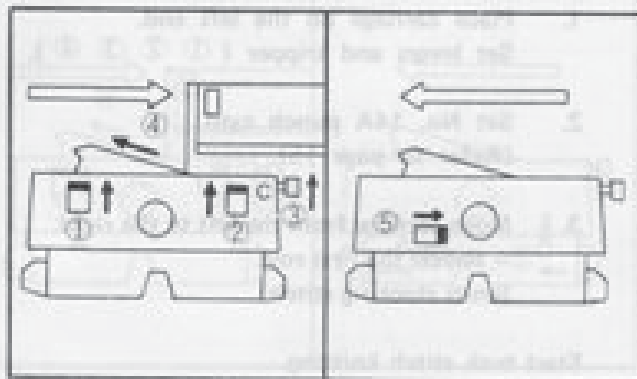

1. Place carriage on the left end. Set levers and tripper. (1 . 2 . 3 . 4.)

When starting punch card selection, make sure Card Feed Tripper is turned outwards as shown in Fig.

2. Set No. 10A punch card (refer to page 15).

3. Move carriage from the left to the right. — selects the first row. (knits stocking stitch) Start fair isle knitting.

4. Set fair isle switch to "COLOUR". (5)

5. Thread 2nd colour (Patterning) yarn into "COLOUR" feeder. Fasten yarn end to a clamp or hold it down below the carriage until 1st row is knitted. (if row counter is required, engage it now).

6. Move carriage from right to left. The 1st row will be knitted and the 2nd needle selection will appear on the needle bed.

7. Knit until the row marked with a circled number which is shown in the slot on the right side of the punch card.

○ mark . . . Change yarn to the another coloured yarn. (see Fig.)

Repeat the above.

\* When no pattern needles are selected (to knit plain sts), remove second colour yarn from the "Colour Yarn Feeder".

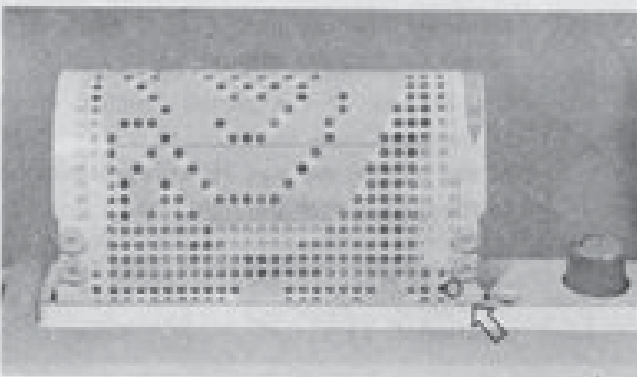
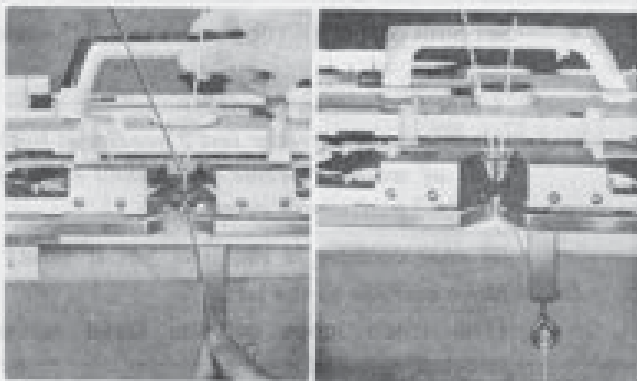

TUCK STITCH KNITTING

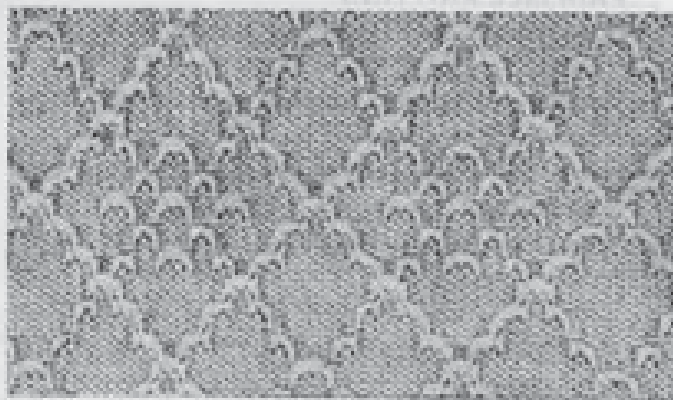

3 rows tucked  
1 row plain knit

Assume casting on is finished.  
(refer to page 12.)

- Hang weights on the both ends of the fabric.

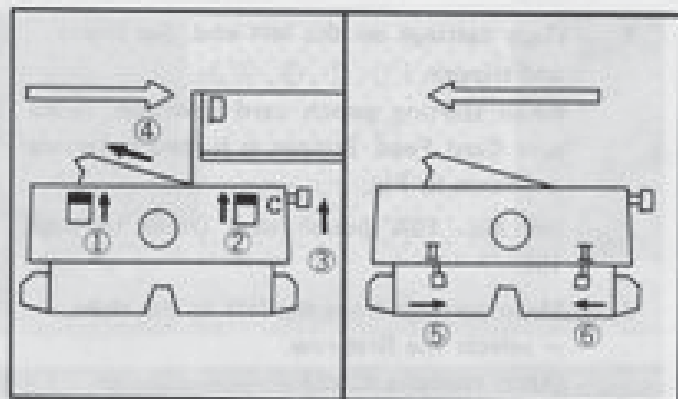

1. Place carriage on the left end.  
Set levers and tripper ( ① ② ③ ④ ).
2. Set No. 14A punch card.  
(Refer to page 15).
3. Move carriage from the left to the right.  
— selects the first row.  
(knits stocking stitch)

Start tuck stitch knitting.

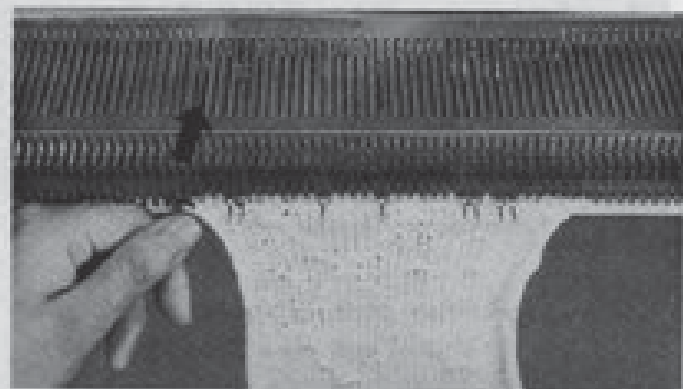

4. Set both partial knitting levers to "II" mark ( ⑤ ⑥ ).
- *A hint for knitting garment:*  
*Always make sure the last 2 needles at both ends of working needle are pushed back to the "B" position in every row.*  
(If row counter is required, set it now.)
5. Move carriage to the left.  
(The stitch loops will be layed across selected needles)

Insert a stop between rows 4 and 5

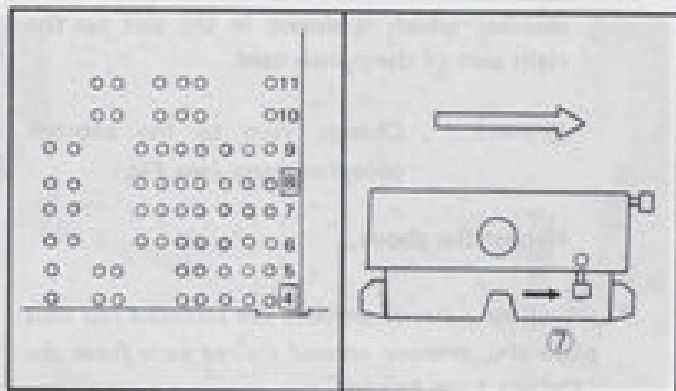

6. Continue knitting until "□" mark on a punch card comes around.  
Change one of the partial knitting levers to the "O" mark according to the direction of the moving carriage. If carriage is moving to the right, switch the right lever. ⑦
- Repeat steps 4 through 6 knitting three rows at position "II" and one row at position "O".

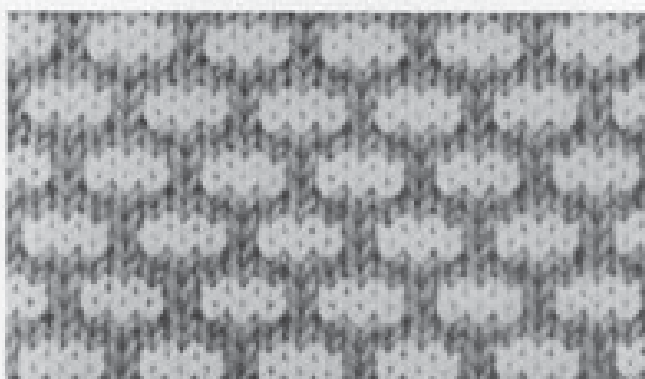

**TUCK STITCH KNITTING (IN TWO COLOUR)**

- 2 rows tucked . . . . . white
- 2 rows plain . . . . . black

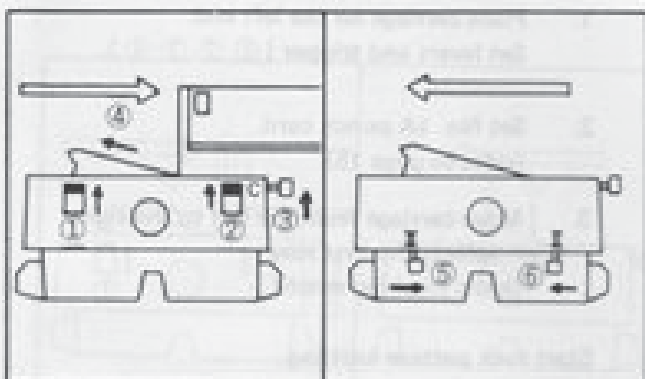

Use No. 13A punch card.  
The white yarn is threaded.

Follow steps 1 through 5 on page 17.

- 6. Knit one row to the right.  
(The stitch loops will be laid across selected needles)
- 7. Change both partial knitting levers to "0" mark. ( ⑦ ⑧ )

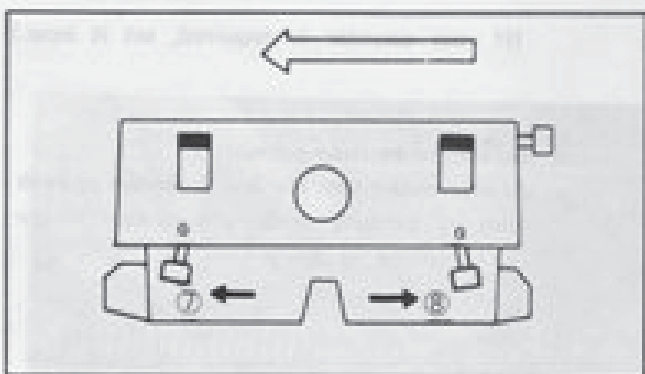

- 8. Remove white yarn and thread black yarn.  
Knit two rows.

- 9. Change both partial knitting levers to " II " mark. ( ⑤ ⑥ )

- 10. Remove black yarn and thread white yarn.  
Knit two rows.  
Repeat steps 7 through 10.

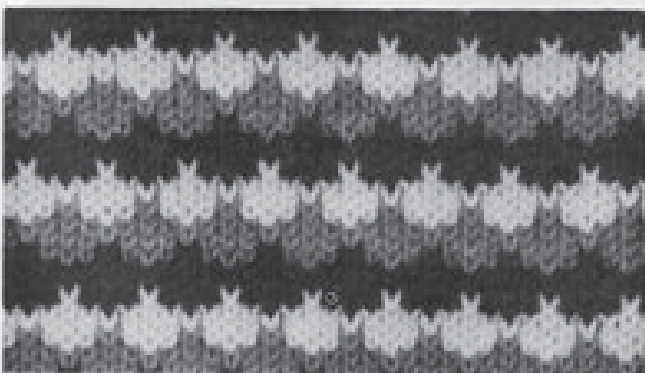

**TUCK STITCH (IN THREE COLOUR)**

Use No. 13A punch card.

- 9. One punch card can offer a variety of patterns. The pattern in the figure can be made by following the steps on page 17, changing the yarn every fourth row at the " □ " mark.

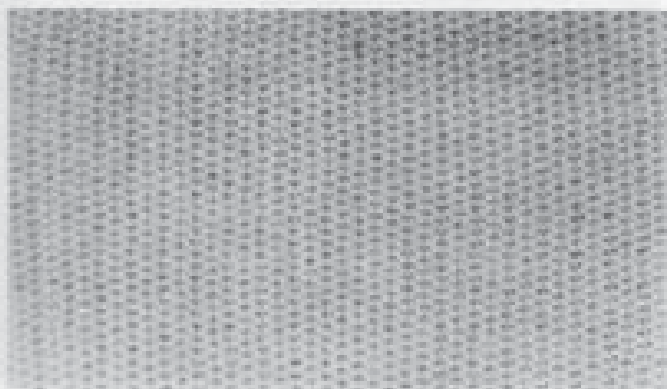

Assume casting-on is finished.  
(refer to page 12)

- Hang weights on the both ends of the fabric.

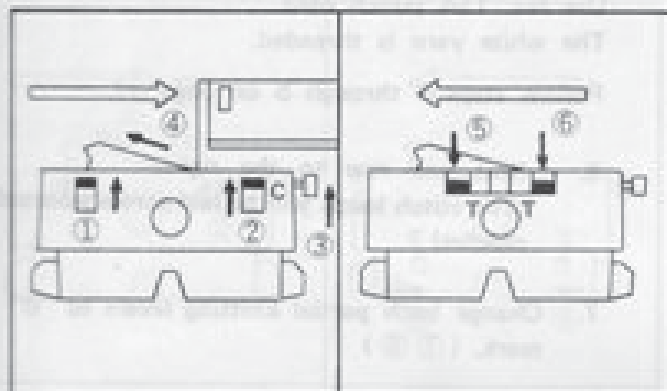

1. Place carriage on the left end.  
Set levers and tripper ( ① ② ③ ④ ).

2. Set No. 1A punch card.  
(refer to page 15)

3. Move carriage from the left to the right.  
– selects the first row.  
(knits stocking stitch)

Start tuck pattern knitting.

4. Set both Tuck Buttons ( ⑤ ⑥ ).

(If row counter is required, set it now.)

- *A hint for knitting garment:*  
Always make sure the last 2 needles at both ends of working needle are pushed to the "D" position in every row.

Continue knitting.

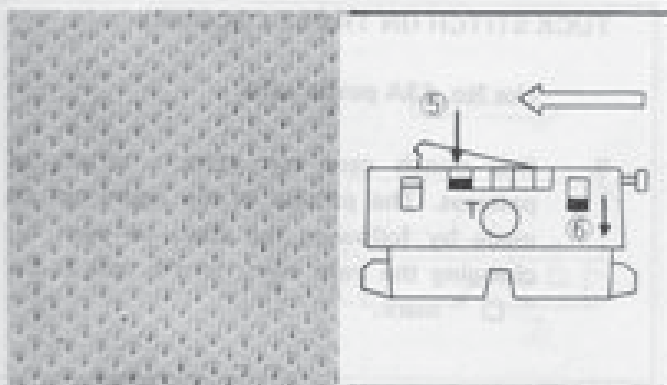
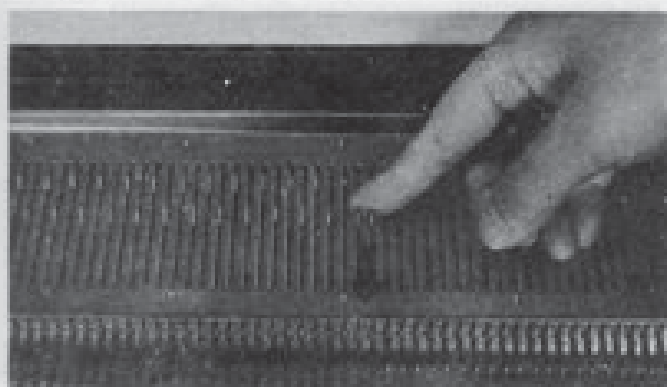

**MOCK MOSS STITCH (by one tuck button)**

Set No. 2A punch card.  
Follow above steps 1 through 3.

4. Set left Tuck Button and the right pattern knit lever to "PLAIN" ( ⑤ ⑥ ).

Continue knitting.

# I HOW TO USE KNITTING MACHINE

## NAMES AND FUNCTION

### MACHINE BODY

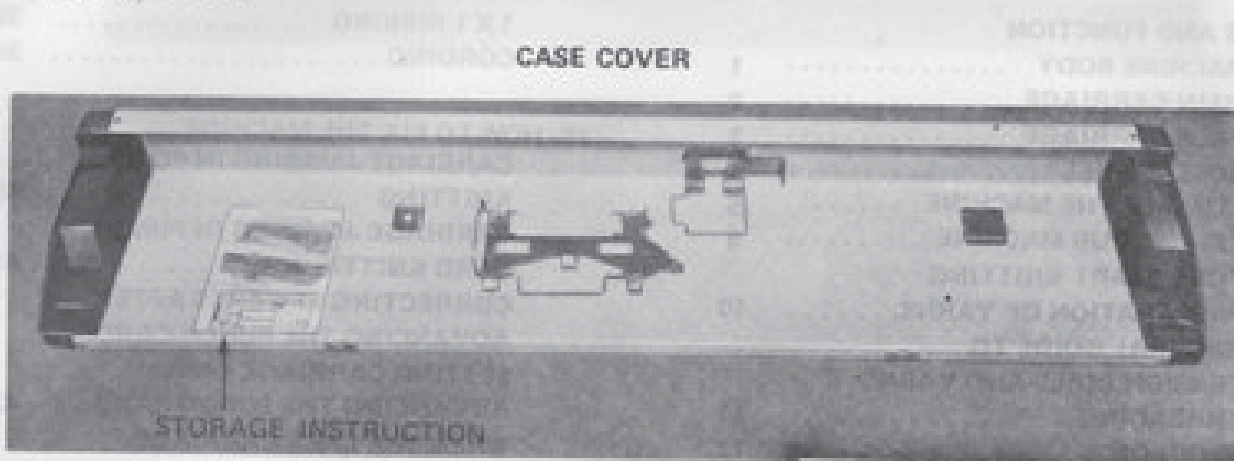

### MAIN BED

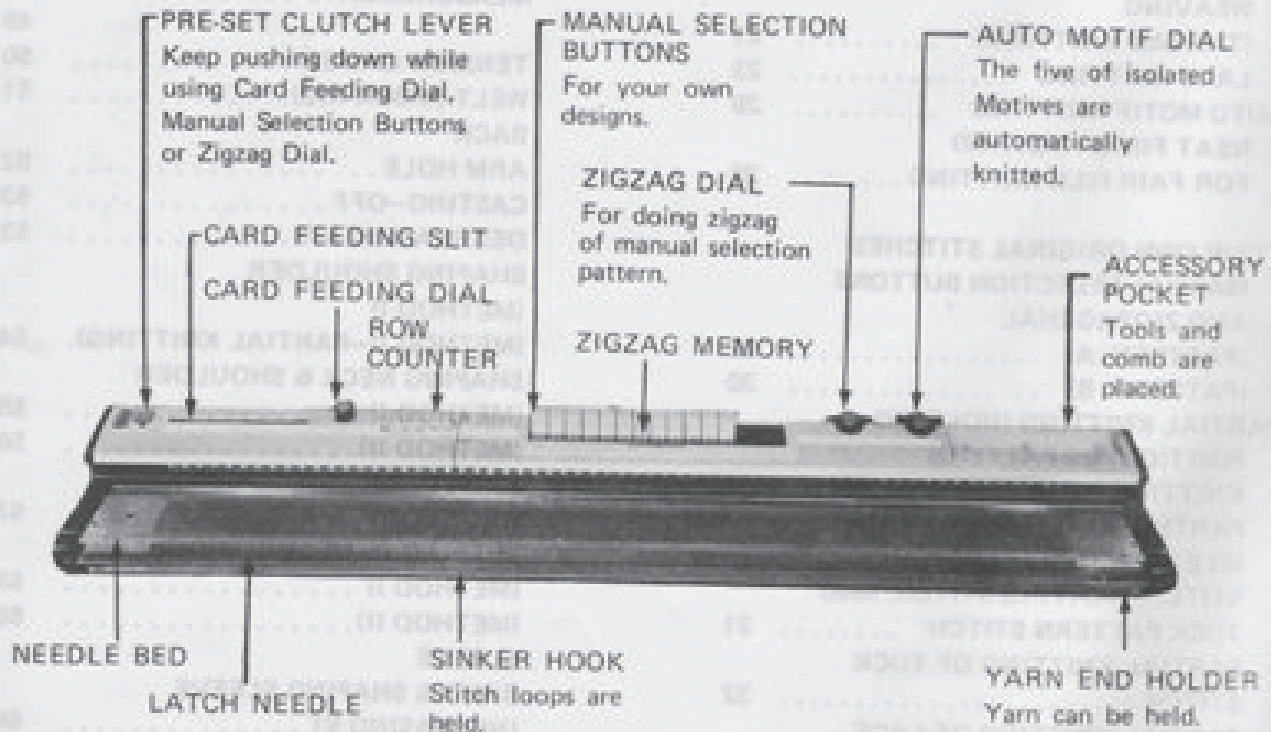

### SLIP LOOP KNITTING

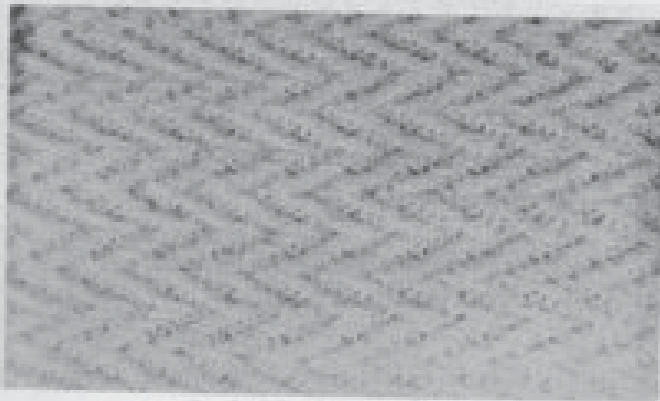

Assume casting-on is finished (refer to page 12).

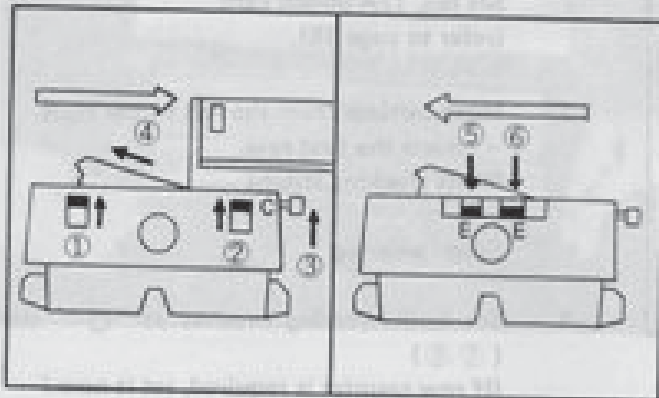

1. Place carriage on the left end.  
Set levers and tripper ( ① ② ③ ④ ).
2. Set No. 18A punch card (refer to page 15).
3. Move carriage from the left to the right.  
– selects the first row.  
(knits stocking stitch)

Start slip loop knitting.

4. Push both Empty Buttons ( ⑤ ⑥ ).

(If row counter is required, set it now.)

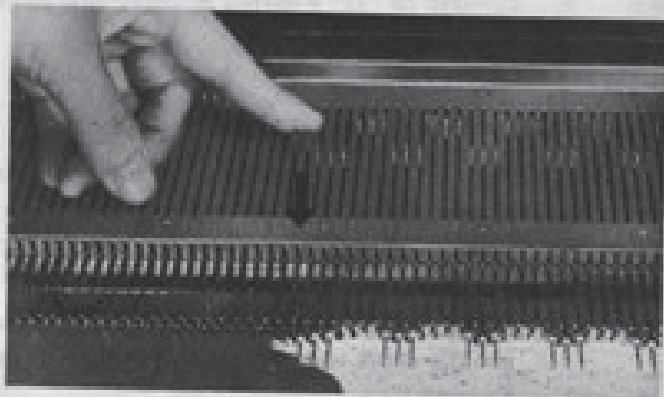

\* *A hint for knitting garment:*  
Always make sure the last 2 needles at both ends of working needle are pushed to the "D" position in every row.

Continue knitting.



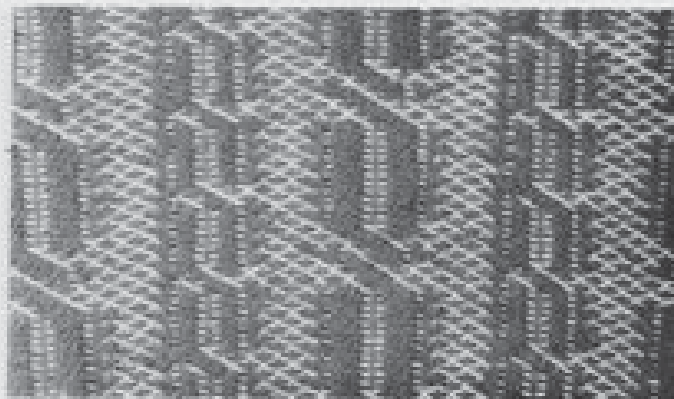

Assume casting-on is finished.  
(refer to page 12)

1. Place carriage on the left end.  
Set levers and tripper ( ① ② ③ ④ ).

\* It is recommended to adjust Tension Dial according to the kind of yarn.

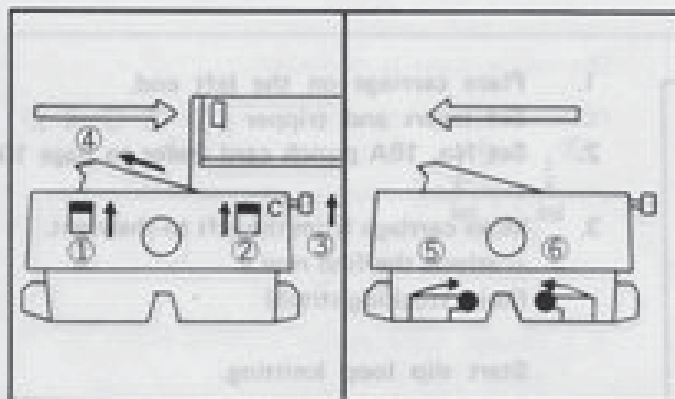

2. Set No. 12A punch card  
(refer to page 15).
3. Move carriage from the left to the right.  
– selects the first row.  
(knits stocking stitch)

Start weaving.

4. Set both weaving brushes at "O" mark.  
( ⑤ ⑤ )  
(If row counter is required, set it now.)

\* Pull the first end needle working opposite carriage to "D" position in every row when they are not selected.

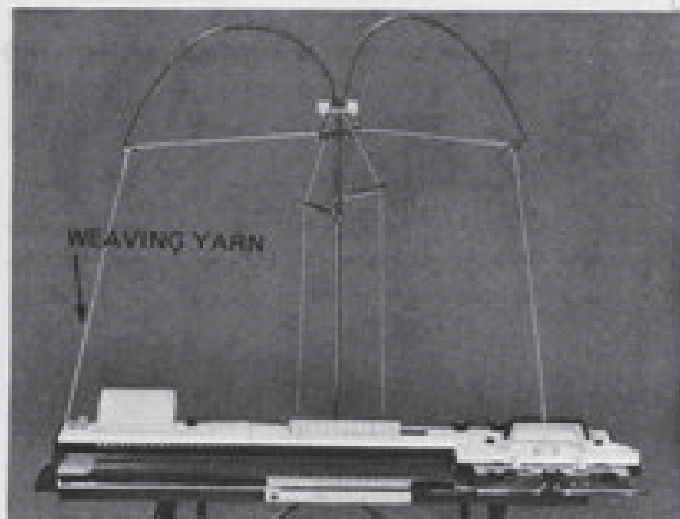

5. Weaving yarn can be threaded like the main yarn.  
Adjust top Tension Dials to suit the yarn's thickness.  
If the tension of the main yarn seems loose, use the short wire by hooking it onto Upper Tension Wire.  
Turn Upper Tension Dial to the (+) direction.

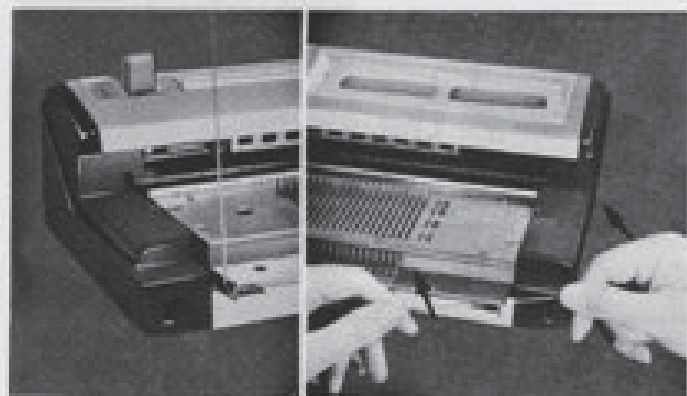

6. Hold the end of the yarn on Yarn End Holder at carriage side. (right in this case)
7. Lay the weaving yarn on the opened latches of selected needles from the carriage side to the opposite side, and hook the end of the yarn on the other Yarn Holder. (left in this case)

FACE KNITTING

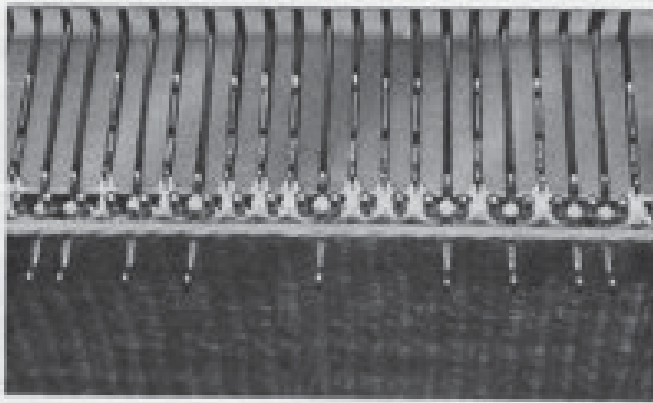

Lay the weaving yarn close to the sinker needles.

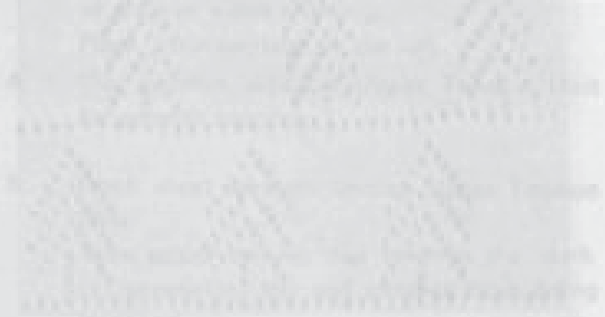

Set back the Weaving yarn about two rows.

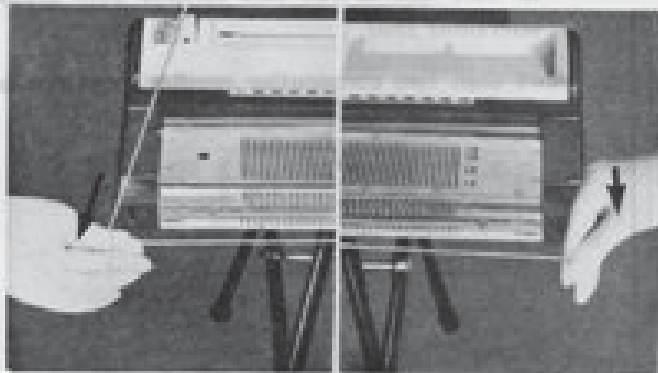

8. Move carriage to the left, then unhook weaving yarn from left Yarn End Guide, and release short end of weaving yarn from right Yarn End Holder.

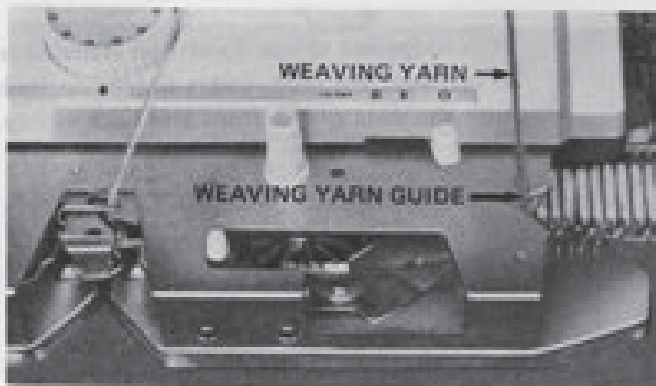
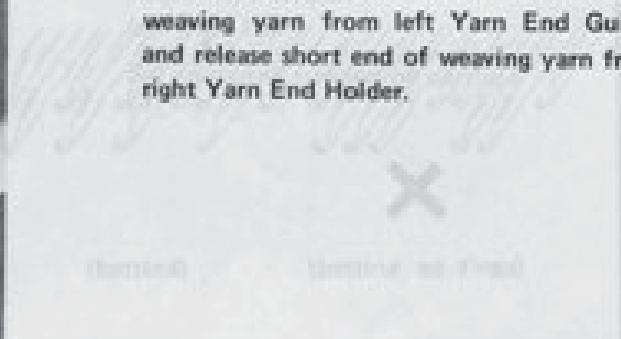

9. From the 2nd row on, be sure the weaving yarn is caught in the Weaving Yarn Guide.

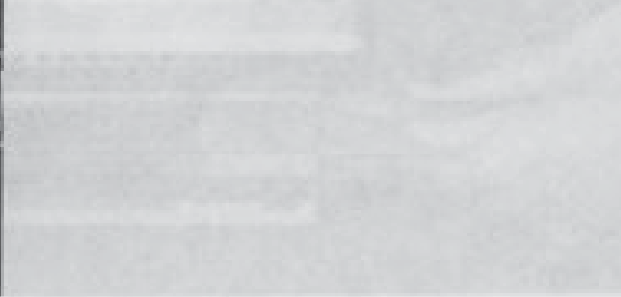

Make sure the carriage is in the

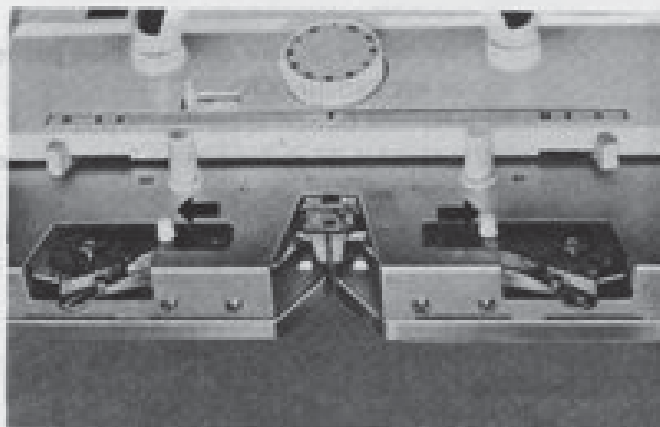

\* Always remember to disengage both weaving brushes to "□" positions when knitting the other pattern stitches than weaving.





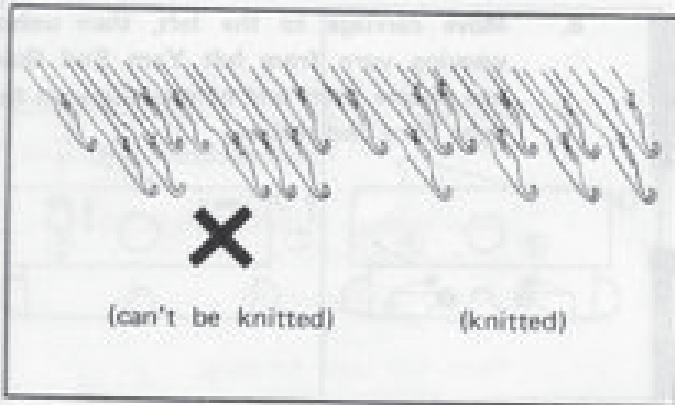
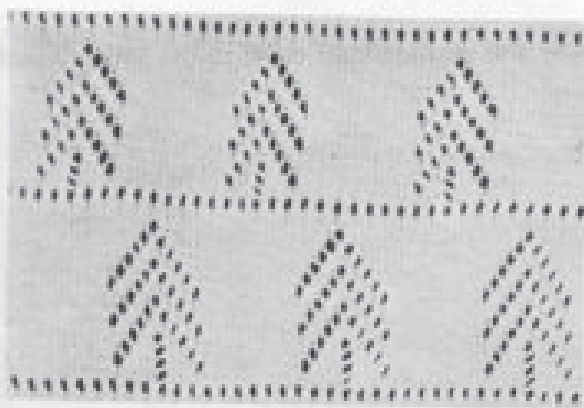

\* Be sure not to run lace carriage over needle selections thus;

More than two consecutive needles must not be selected at the "D" position.

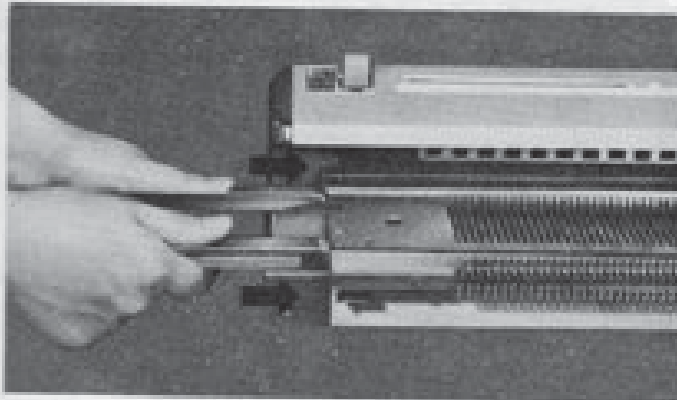

1. It is suggested to use Extension Rails when 2 carriages are used. Insert Extension Rails into the slots of the front and back firmly.



2. Fix the handle on lace carriage, then put it on the left Extension Rail. Push Release Button as carriage is placed. Refer to page 42 as for setting lace carriage on Extension Rail.

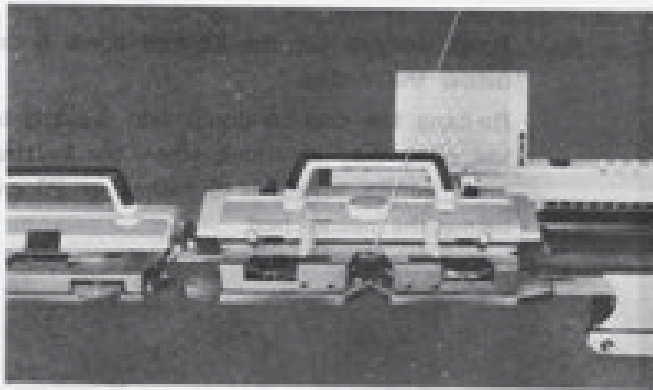

3. Before starting, knit about 2 inches or 5 cm of plain or waste knitting. Place main carriage on the left.
4. Use paraffin wax on Upper Tension Unit for smooth knitting.
5. Hook short wire on leading Upper Tension Wire. Turn upper tension dial towards the mark (+) preventing the end stitches from being loosened. Be sure the Threading yarn is not too loose.

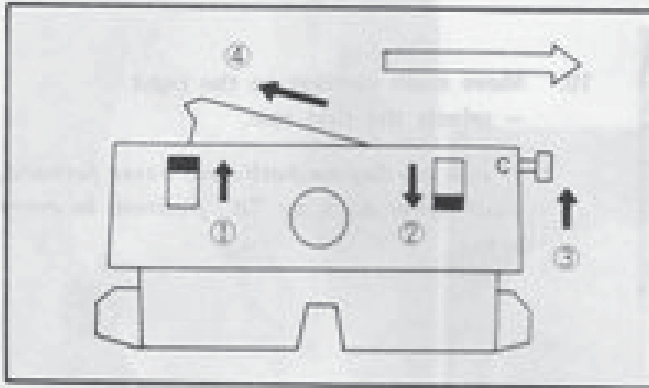

6. Adjust tension dial. (see page 10)
7. Set levers and trippers on carriage (1 2 3 4).

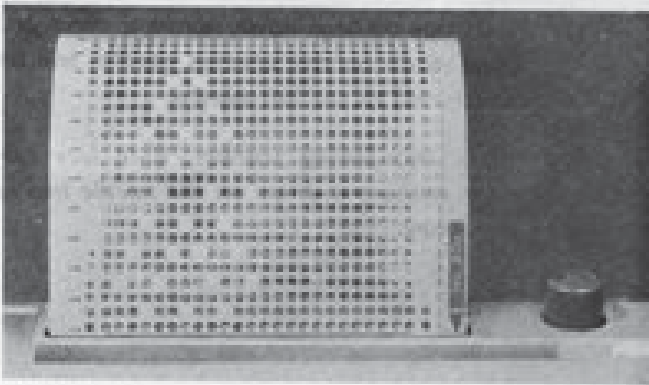

8. Set No. 20A punch card.

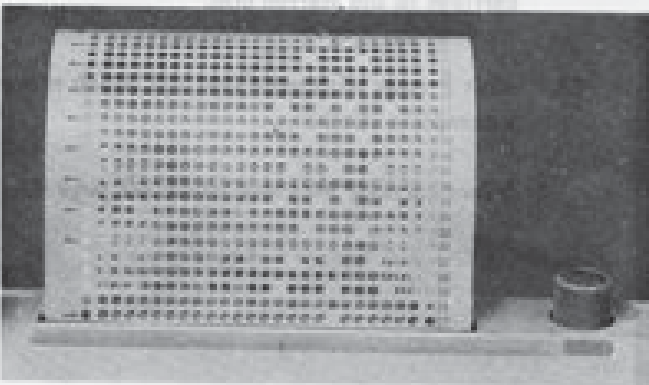

→ Mark . . . Run lace carriage in the direction of the arrow.

○ Mark . . . Switch the lever setting. Remove lace carriage and place it on the opposite end.

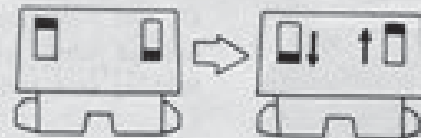

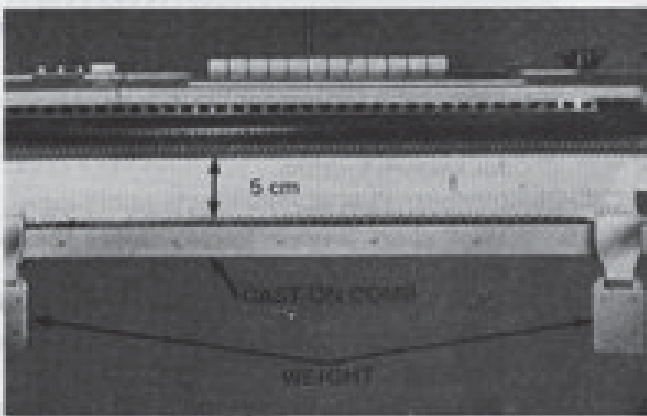

9. Hang weights on the knitted piece 5 cm below the sinker.

Re-hang the cast-on comb and weights in the same way as above when the knitted piece comes to about 8 inches or 20 cm below the needle bed.

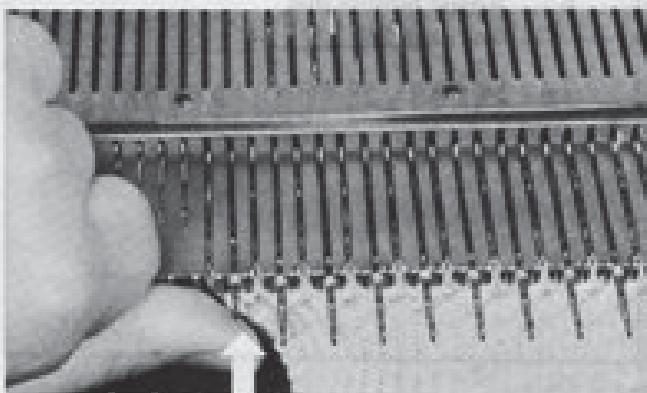

10. Move main carriage to the right — selects the first row.

\* If two needles on both ends come forward, push them back to "B" position in every row.



(If row counter is required, engage it now.)

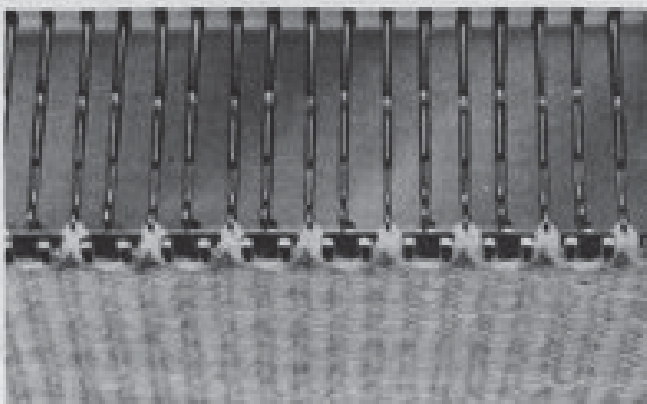

11. Slide lace carriage slowly across to the right. Each stitch on the selected needles will be transferred to the left needle.

\* While transferring stitches, slide lace carriage pushing it down on the needle bed as in ironing.

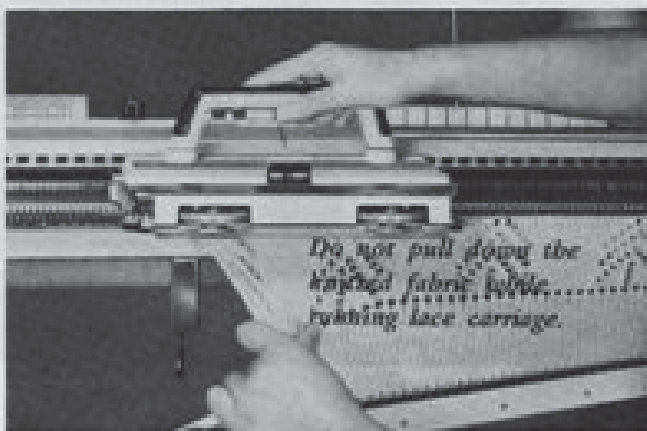

12. After transferred all stitches, slide back lace carriage to the started end.

13. Knit 2 rows with main carriage which makes a complete stitch.

\* If lace carriage becomes stuck, see page 43.



## 6. AUTO MOTIF KNITTING

... shall we try panel and motif knitting. Just turn a dial . . . that's a knack.

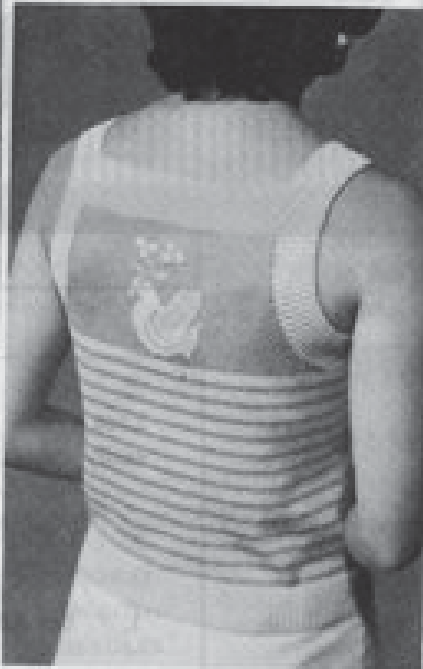
Shall we try panel and motif knitting. Just turn a dial . . . that's a knack.



A system of auto motif needle selection will engage 120 needles.  
One section is 24 stitches and there are 5 sections to choose from.

The numbers on Auto Motif Dial represent five sections marked with "   " on the plastic film under the latch needles. When the dial is turned to 1, the 1st section of needles on the left will be selected.

**Number of Auto Motif Dial**

No. of Auto Motif Dial	0	1	2	3	4	5
Working Needle Section	Neutral position for normal knitting	Left 60 - 37	Left middle 36 - 13	Middle 12 - 12	Right middle 13 - 36	Right 37 - 60

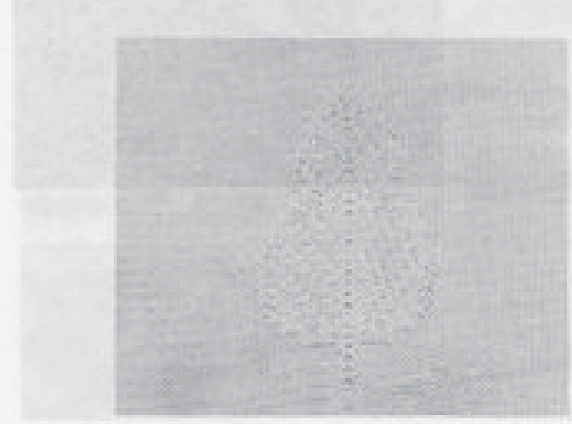
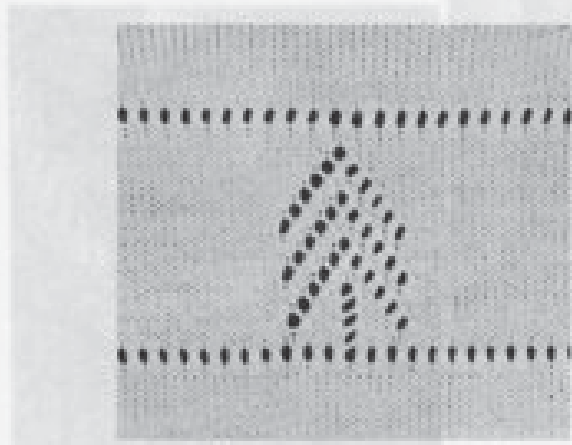
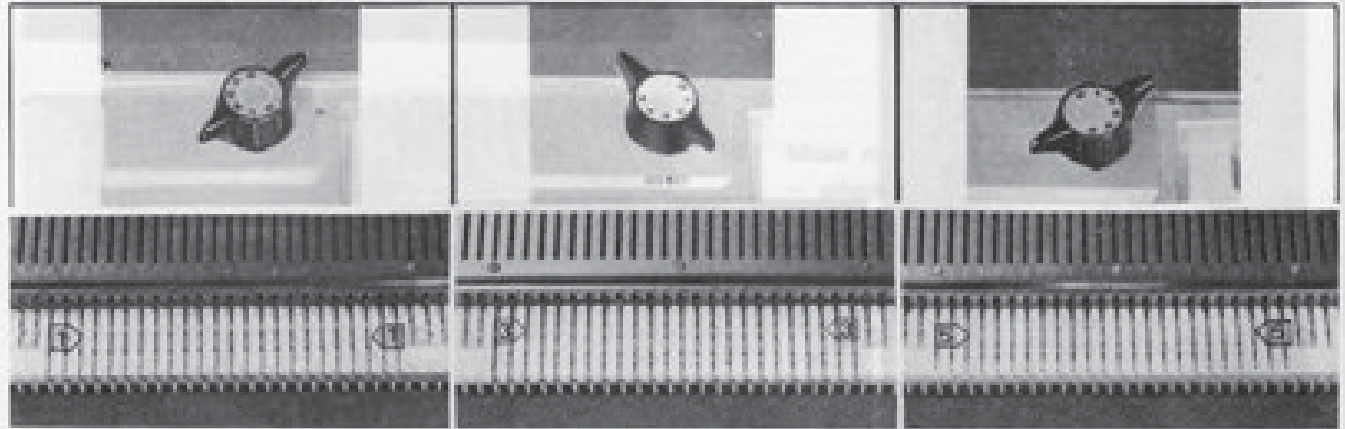

Lace, Tuck and Weaving motif knittings will be easily done by this method.

1. Set Auto Motif Dial at precise number.
  2. After transferred all stitches, slide back free carriage to the started end.
  2. Set a card and carriage for each type of knitting, then knit as usual.
- \* Hang weight below the motif knitted section especially for lace knitting.



### NEAT FINISH METHOD FOR FAIR ISLE KNITTING

Prepare two pieces of main colour yarn about 80 cm or 30 inches in length.  
(If possible, slightly finer yarn.)

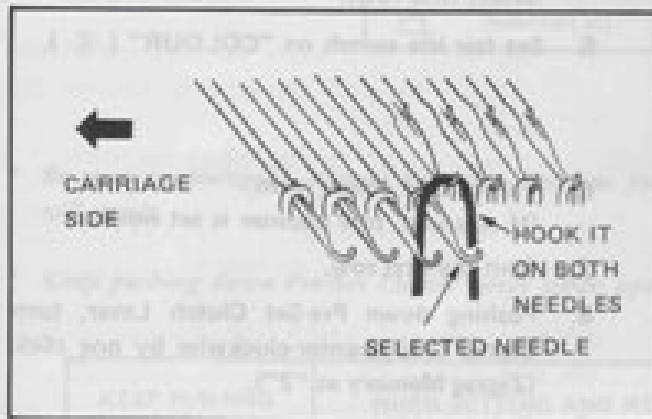
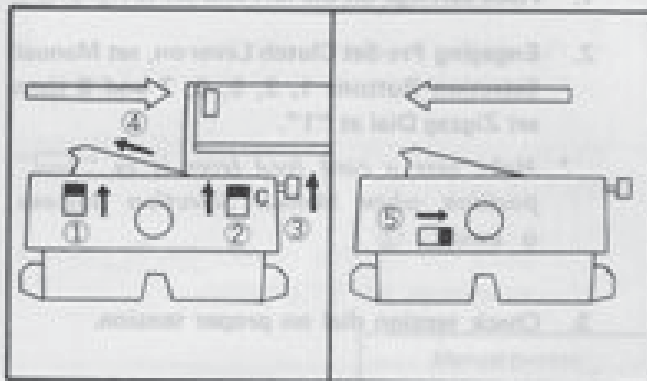

• Pull up the patterning yarn lightly above yarn feeder as you start to knit in especially for wide-knitting or thick yarn in use.

• Use short wire with Upper Tension Wire on which the patterning yarn is threaded.  
Turn Upper Tension Dial to ( + ) direction.

1. Set Auto Motif Dial at selected number.
2. Place carriage on the left and set it ( ① ② ③ ④ ).
3. Insert Punch Card.
4. Move carriage to the right, and according to the punch card, a stocking stitch will be knitted and needle selection will be done in the selected block of needles at the same time.
5. Set fair isle switch on "COLOUR" ( ⑤ ).
6. Thread the second colour yarn.
7. Move carriage to the left and the first row of fair isle stitch is completed.
8. Hook a yarn piece to the selected needle at the first end opposite to carriage and the next needle in "B" position, as shown in Fig.
  - Pull a piece of yarn lightly or hang a transfer needle as you start to knit.
9. Move carriage to the right.
10. Hook an another piece of yarn on the two needles opposite side in the same way as step 8.

## 7. YOUR OWN ORIGINAL STITCHES

### MANUAL SELECTION BUTTONS AND ZIGZAG DIAL

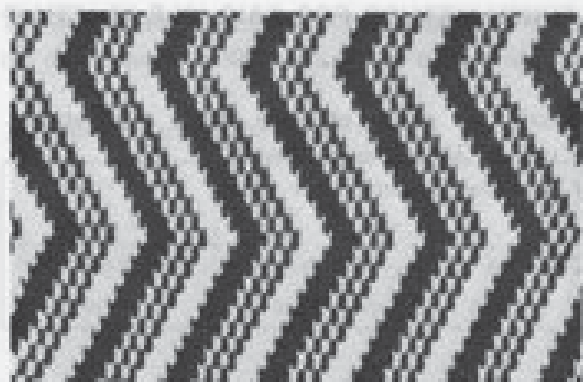

#### PATTERN. A. – ZIGZAG PATTERN –

Shall we try a simple stripe zigzag pattern, or a border pattern by using just handy Manual Selection Buttons and Zigzag Dial?

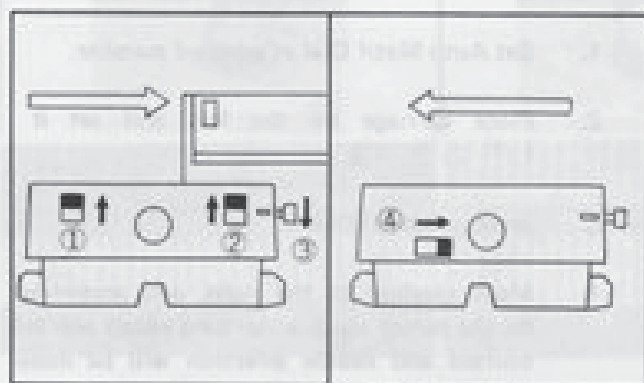

1. Place carriage on the left and set it (①②③).
2. Engaging Pre-Set Clutch Lever on, set Manual Selection Buttons 1, 3, 5, 6, 7 and 8 then set Zigzag Dial at "1".
  - \* Make sure a card feed lever is in "□" position when Manual Selection Buttons is used. (③)
3. Check tension dial on proper tension.

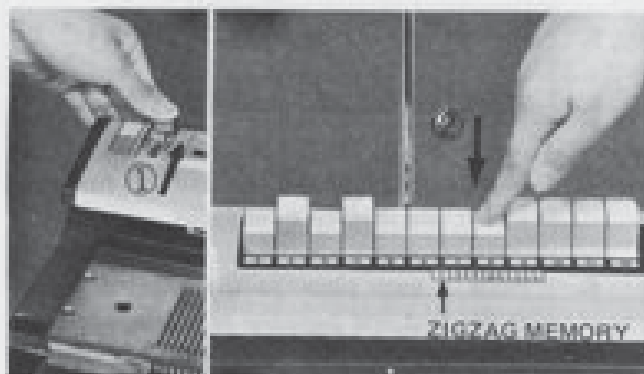

4. Move carriage to the right (select first row).
5. Set fair isle switch on "COLOUR" (④).

6. Thread 2nd colour yarn (If required, row counter is set now).
7. Knit the first row.
8. Pushing down Pre-Set Clutch Lever, turn Zigzag Dial counter-clockwise by one click (Zigzag Memory at "2").

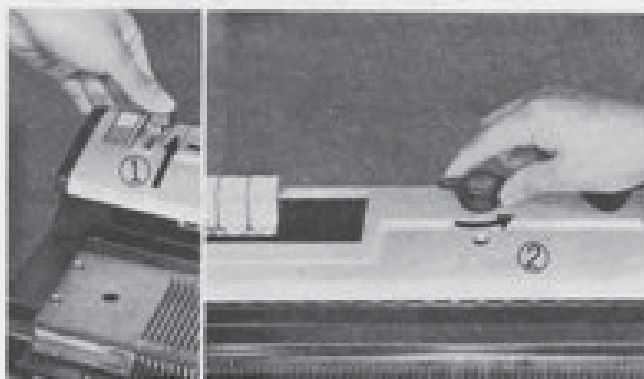

9. Knit two rows.
10. Every two rows turn Zigzag Dial by one Click.
11. Continue above steps until Zigzag Memory is shifted on "12", then turn it clockwise back to "1".

\* Be sure to engage Pre-Set Clutch Lever on, when releasing Manual Selection Buttons (see page 30).

**PATTERN B. — BORDER PATTERN —**

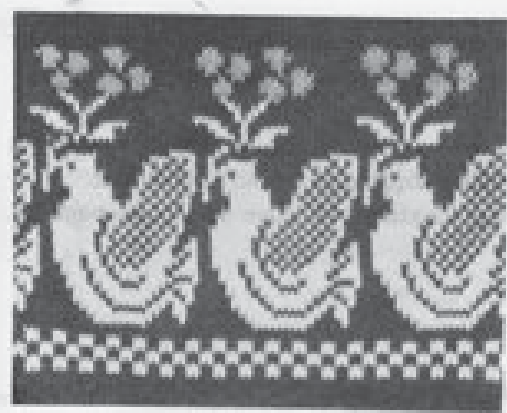

1. Place carriage on the left and set it.  
(① ② ③ See page 29).
2. Holding Pre-Set Clutch Lever on, set Manual Selection Buttons 1, 2, 5, 6, 9 and 10. Set Zigzag Dial on "1".
3. Check if a tension dial on carriage is correct.
4. Run carriage to the right (Select the first row).
5. Set fair isle switch on "COLOUR" (④).
6. Thread the 2nd colour yarn. (If required, row counter is set now).
7. Knit one row.
8. While pushing down the Pre-Set Clutch Lever, turn Zigzag Dial to "3".
9. Knit two rows.
10. Turn Zigzag Dial back to "1".  
— shift Zigzag Dial to "1" or "3" every two rows.

Manual Button	Needle
up(released)	Remain at B position
down(set in)	Selected to D position

- Be sure to disengage Manual Selection Buttons for punch card knitting otherwise a mix of both selections will result.
- Keep pushing down Pre-Set Clutch Lever while operating M.S. Buttons, Zigzag Dial and Card Feeding Dial.

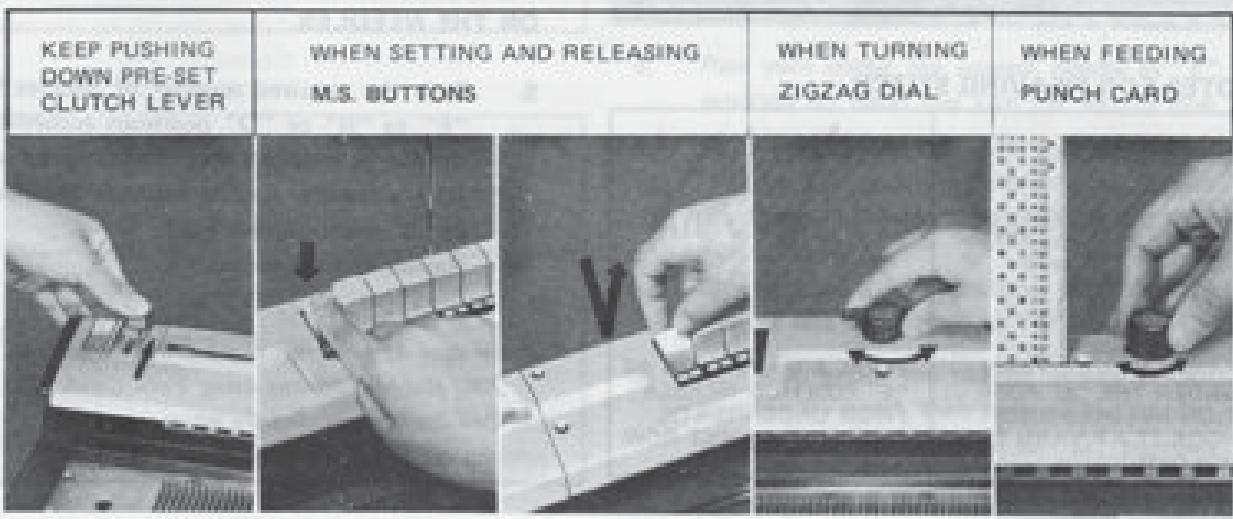

Repeat Steps 1 through 5.



## 8. PARTIAL KNITTING (HOLDING POSITION) OF PATTERN KNITTING

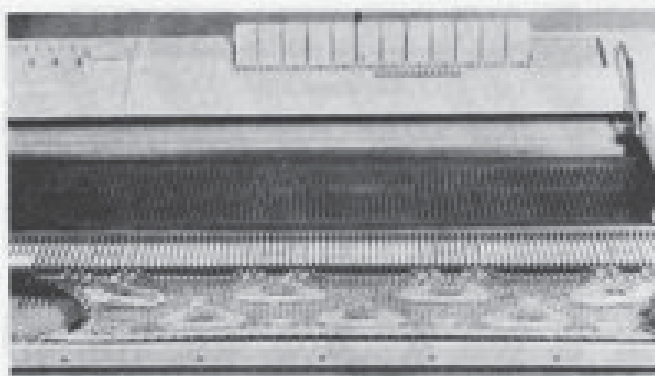

Figure 8-1: Partial knitting with 5 needles in "E" position and 5 needles in "B" position.

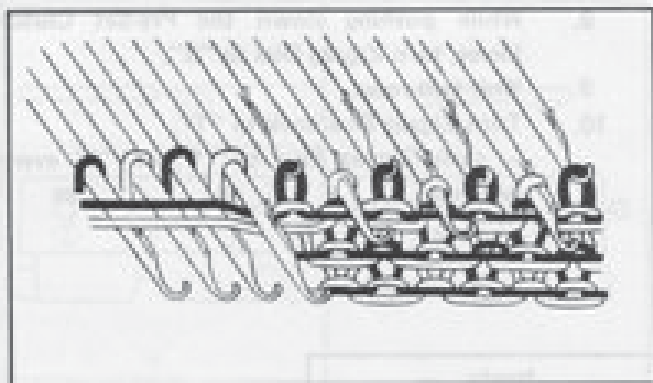
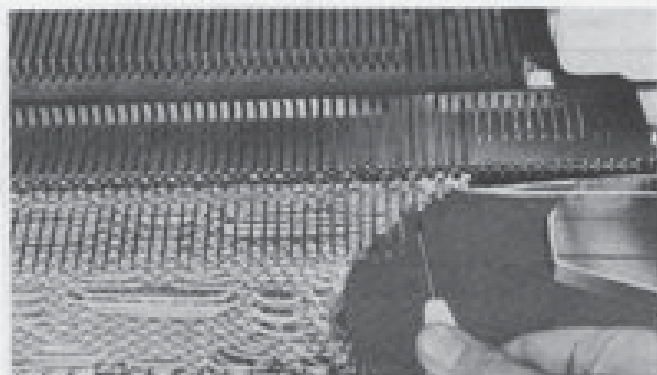
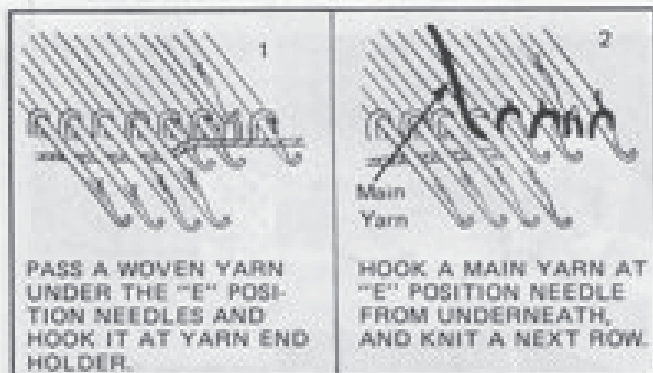

Figure 8-2: Partial knitting with 5 needles in "E" position and 5 needles in "B" position.



### NOTES FOR WEAVING STITCH



This is a useful basic knit for shaping a shoulder line, a bust dart, a sock, or a flared skirt.

This is a way of decreasing or increasing stitches while holding stitches on needles unknitted. For partial knitting in a plain stitch, see page 54.

### PARTIAL KNITTING OF FAIR ISLE STITCH, SLIP LOOP STITCH, WEAVING STITCH, AND TUCK PATTERN STITCH.

- \* The needles are already selected.
- Set both partial knitting levers at "I" mark.

### DECREASING STITCHES HOLDING STITCHES ON THE NEEDLES.

1. Bring the working needles (ex. 5) opposite to carriage, to "E" position.
2. Knit one row.  
Stop carriage a few cm away from the working needles.
3. Pass both yarns under the first end needle in "E" position opposite to carriage by hand (see Fig.).  
This avoids a hole showing on the fabric.
4. Knit the second row.  
Repeat the steps 1 through 4.

### INCREASING STITCHES HOLDING STITCHES ON THE NEEDLES.

5. Push the required number of needles from "E" to "B" or "D" positions according to the needle selection over the knitting needles. (Use a transfer tool to set back the needles in "B" position, see Fig.)  
Repeat steps 2 through 5.

- \* In case of Weaving, book a woven yarn at Yarn End Holder without using Yarn Guide.
- \* Pull both yarns slightly up as you knit.

## PARTIAL KNITTING OF TUCK STITCH

### DECREASING STITCHES HOLDING STITCHES ON.

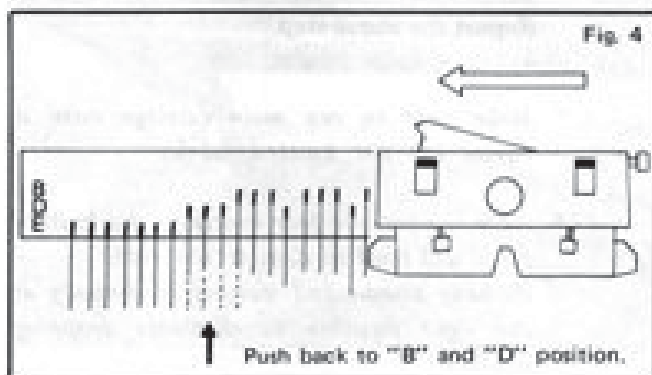
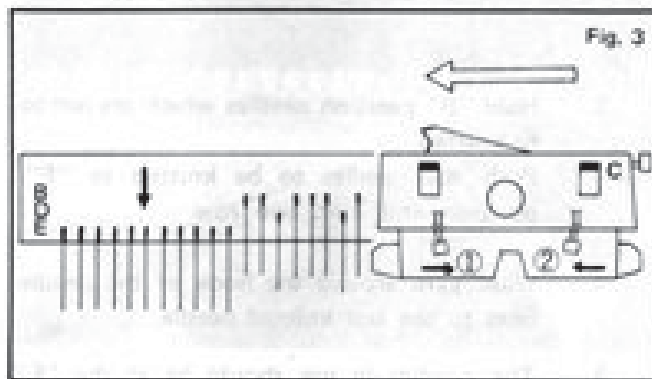
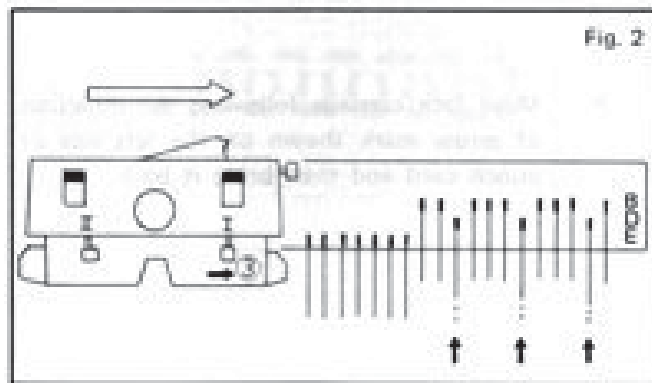
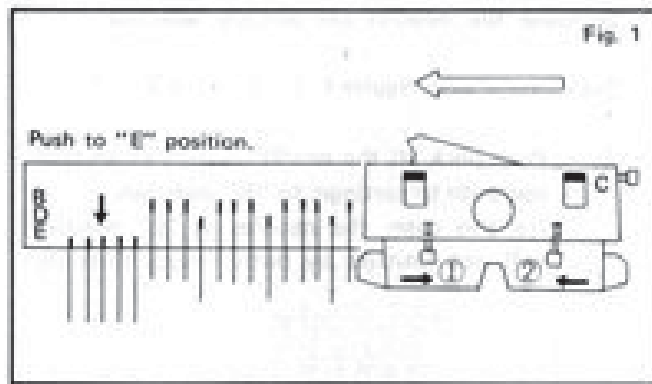

1. Set both partial knitting levers at " I " ( ① ② ).

2. Bring the required number of the working needles (ex. 5) opposite to carriage to the "E" position. Knit one row (Fig. 1). Stop carriage a few cm away from the working needles.

3. Pass yarn under the nearest needle at "E" position by hand.

(Refer to fair isle knitting page 31)

Knit the second row.

4. Pull another certain number of needles (ex. 5) to "E" position and knit the third row.

5. Set leading partial knitting lever at " I " mark. ( ③ right in this case)

6. Pass yarn under the nearest needle at "E" position and push back patterning "E" position needles to the "D" position. (Fig. 2) (needles at "D" go back to "B" position). Repeat steps 1 through 6.

### INCREASING STITCHES HOLDING STITCHES ON.

Where increasing, bring needles opposite side to carriage, to the "E" position.

Leave some "B" and "D" needles close to carriage.

1. Set both partial knitting levers at " I " ( ① ② ).

2. Knit one row.

3. Pass yarn under the nearest needle at "E" position by hand and knit the second row.

4. Push back some "E" position needles to "B" or "D" position following stitch patterns using transfer tool and knit the third row. (Fig. 4)

5. Change the partial knitting lever on the leading side of carriage to " I " ( ③ ).

6. Pass yarn under the nearest needle at "E" position by hand, then push all the needles which tuck the stitches to "D" position and knit.

Repeat steps 1 through 6.

## PARTIAL KNITTING OF LACE STITCH

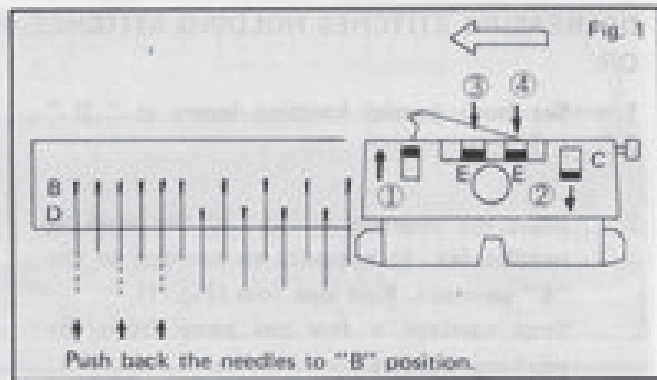

Suppose the needles are already selected.

Set carriage as in figure ( ① ② ③ ④ )

1. Push back all the needles not to be knitted, opposite to carriage, to "B" position. (In this case, the needles in "B" position will not be knitted by both Empty Buttons.)

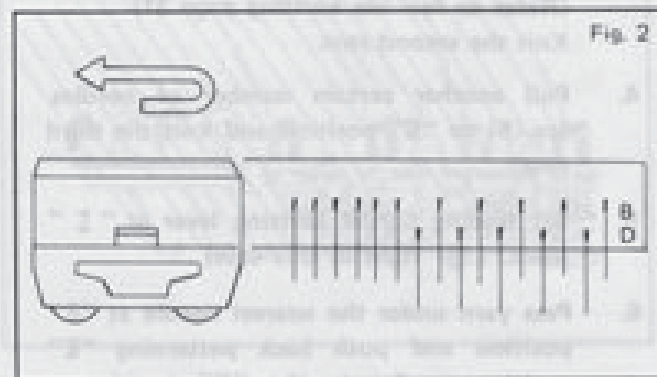

SLIP LOOP STITCH, WEAVING  
LACE PATTERN STITCH

2. Move lace carriage following the direction of arrow mark shown on the left side of punch card and then bring it back.

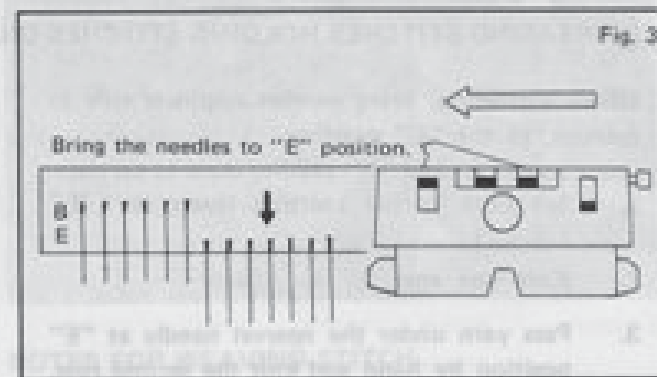

3. Hold "B" position needles which are not to be knitted. Push the needles to be knitted to "E" position and knit one row.
4. Wind yarn around the hook of the needle next to the last knitted needle.
5. The needles in use should be at the "E" position. Knit the second row.

Repeat the above step.

- \* Make sure to run main carriage until it comes off the knitted fabric.
- \* As you continue lace knitting, the knitted piece will tend to slant to one side. Re-bang combs and weights continually at the right position to eliminate dropping stitches.

## 9. FUNDAMENTAL HINTS

MAM TOON

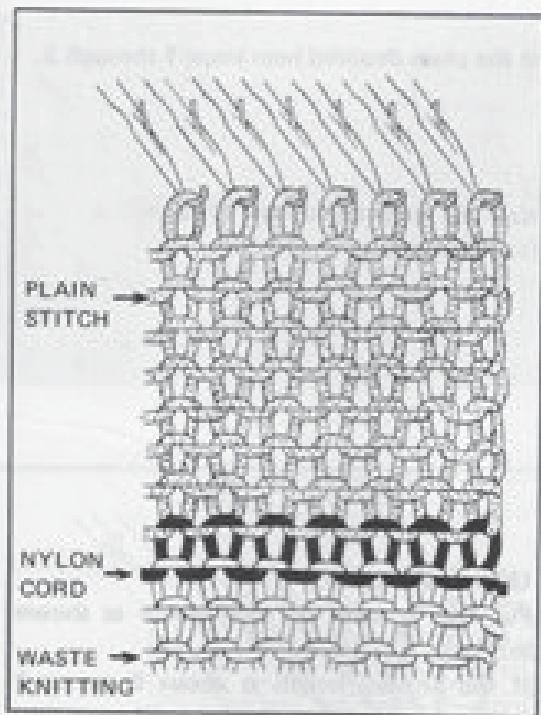
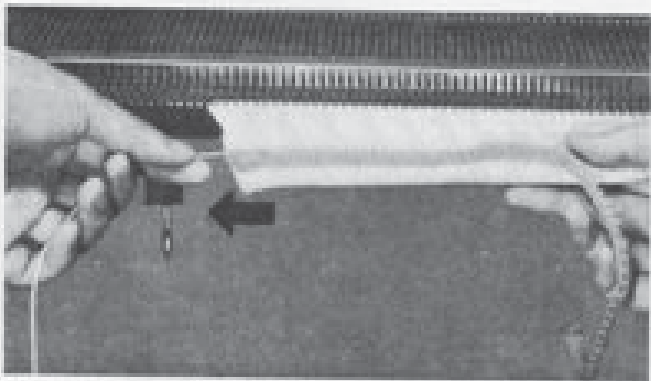
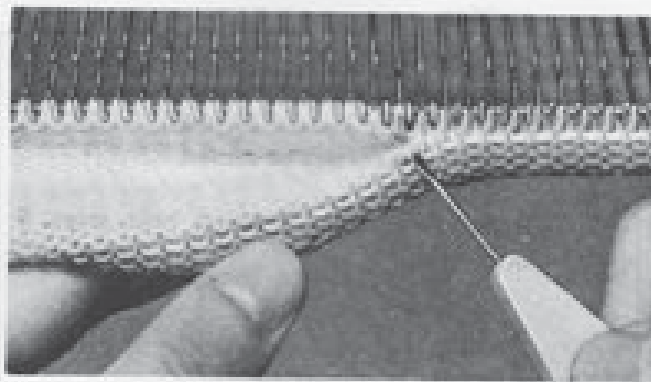

Diagram illustrating the construction of a plain doubled hem.

Diagram illustrating the construction of a plain doubled hem.



### PLAIN DOUBLED HEM

This method will be very useful for neck bands, front bands of cardigans, cuffs, hems of skirt, welts, etc.

1. Knit 7 or 8 rows of waste knitting which will be taken off afterwards (normally done with a contrast colour)
2. Unthread the waste yarn.  
Knit 1 row with nylon cord.
3. Thread the main yarn.
4. Knit twice as many as required number of rows.
  - By using a higher tension over 1 row at the folding point, it will give you a neater finish.
5. Pick up all the first stitch loops next to the nylon cord onto the needles.
6. Knit one row with a few numbers higher tension dial.  
Remember to turn tension dial back to normal knitting.
7. Knit a few rows.
8. Pull out the nylon cord so that the waste knitting piece will drop off.

The plain doubled hem is completed.

PLAIN DOUBLED HEM

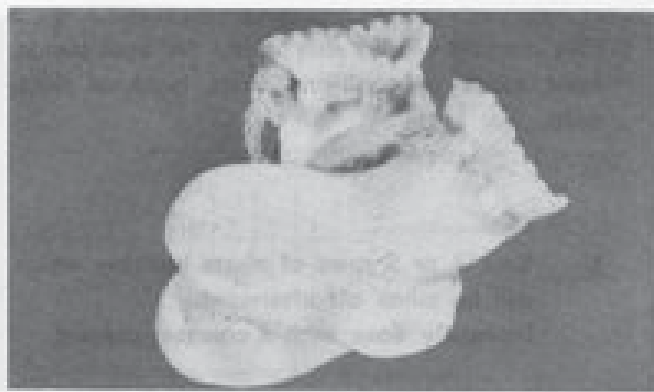

away from the work with the  
left hand while you knit

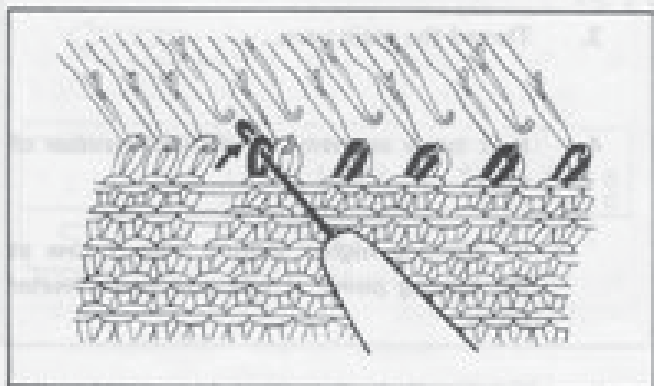

knit the edge from the  
right side

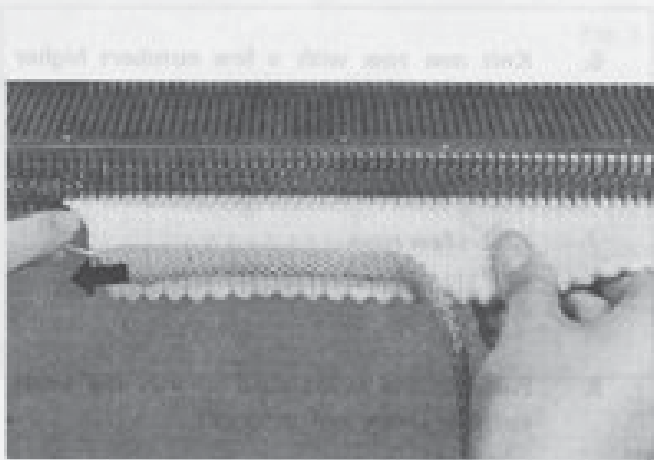

pick up the edge stitches

PICOT HEM

Repeat the plain doubled hem steps 1 through 3.

4. Knit the required number of rows (ex. 10 rows).

5. Use transfer tool.  
Put two stitches on one needle as shown in Fig.  
If the knitted length is about 5 cm or 2 inches, lace carriage can be used.  
Weights and the Cast-On Comb must also be used.

Make sure all the needles are in the "B" position.

6. Knit 1 row more than required rows (ex. 10 rows + 1 row = 11 rows) so that the hem will be settled.
7. Repeat the plain doubled hem steps 5 through 8.

The picot hem is completed.



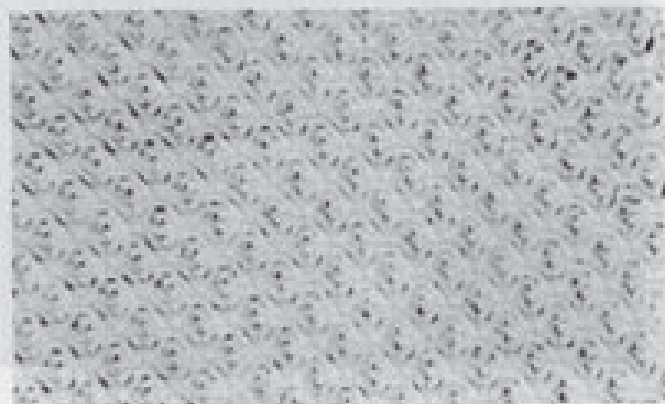

This is not exactly called as a lace knit, though it creates lacy effect with the combination of the tuck stitch and the long loops between them.

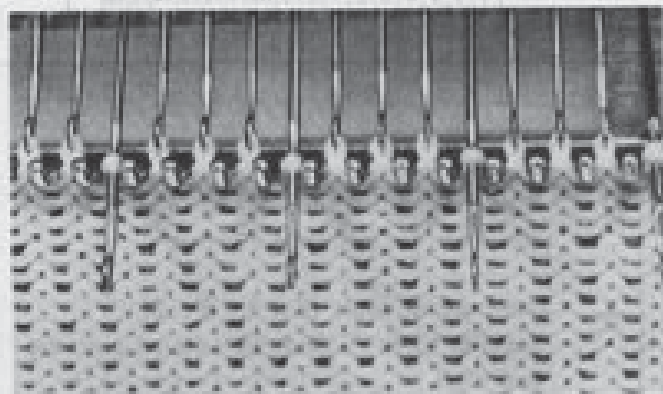

Use No. 13A punch card.

For carriage setting see page 17.

It is recommended to hang the weights at each end.

1. Select needles.



2. Transfer both sides of stitches next to the selected needles onto the middle selected needle, then bring it out to the "D" position.



3. Be sure to push the empty needles back to the "A" position.

Knit in the same way as the tuck stitch on page 17.

\* *Keep re-hanging the knitting weights at the both sides to eliminate dropping stitch.*

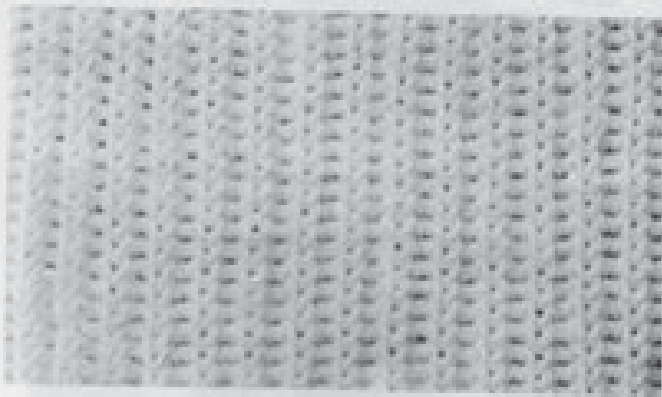

**1 x 1 RIBBING**

**CARRIAGE LATCHING IN PLAIN KNITTING**

**A hint for making a garment:**

To get neat seams, it is recommended not to unravel the two stitches at the left end and one stitch at the right end of the fabric.

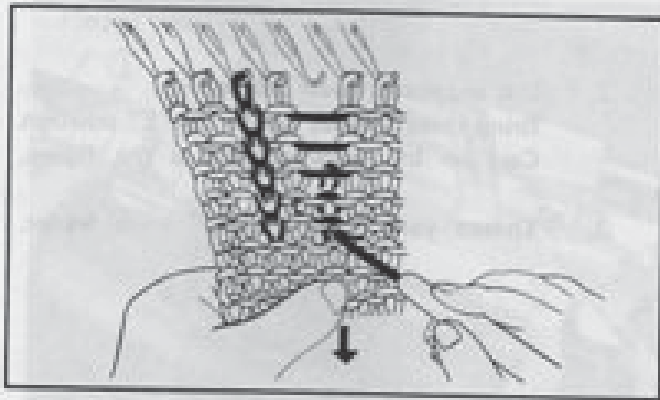

1. Set tension dial one number lower than plain knitting.
2. Knit the required number of rows.
3. Insert latch tool into the first row where the ribbing starts. Drop and undo the stitches down to the beginning of ribbing by pulling the knitted piece downwards by the left (right) hand while holding latch tool with the right (left) hand.

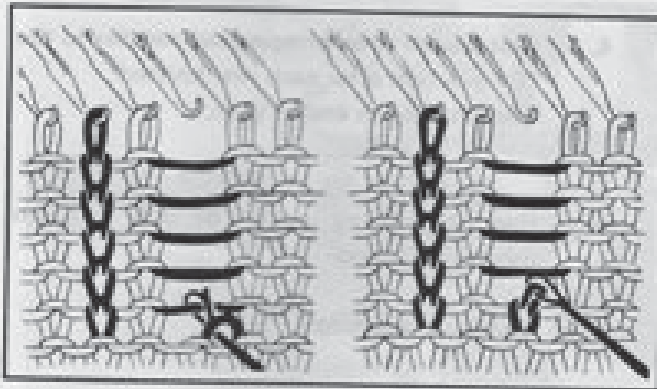

4. Pull the tool toward you. The latch will close and the former stitch loop will slip over the tip. This forms one stitch.

Repeat these steps a half inch and repeat a row of plain knitting at 11

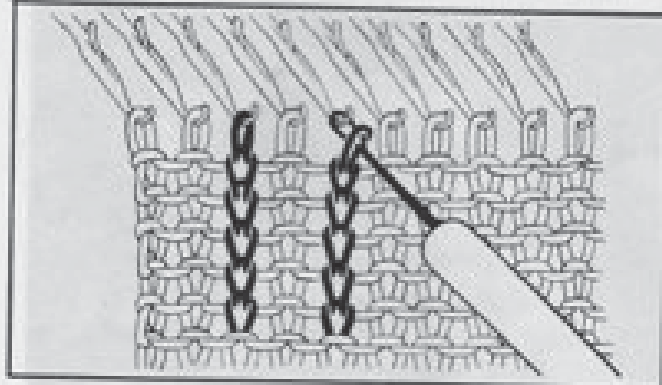

5. Repeat the above up to the top stitch and hook the stitch loop back onto the needle hook.



**CORDING**

This knitted cord is very cute for the ties of booties, poncho, etc.

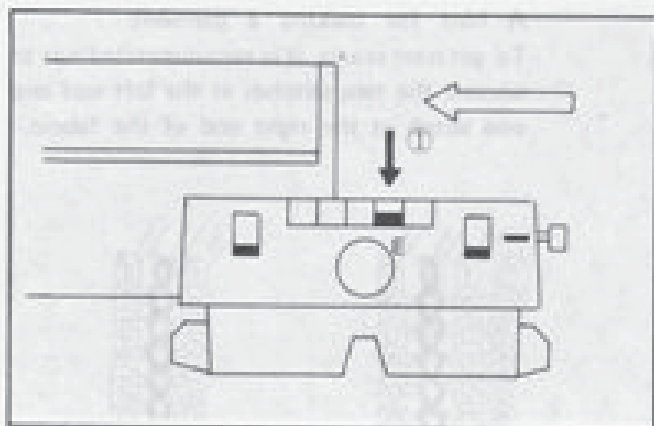

1. Place carriage at the right.  
Push the right Empty Button in (Ⓛ).

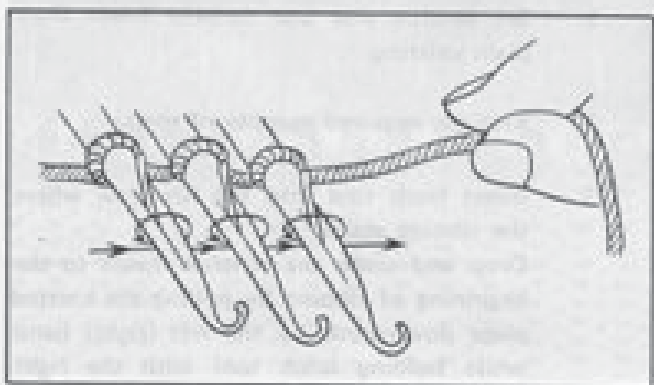

2. It is suggested to use 3-5 needles.  
Bring these needles out to the "E" position.  
Cast on by winding yarn as the figure.

3. Thread yarn into "PLAIN" yarn feeder.

4. Knit several rows bringing out needles to the "E" position after each row knitted.  
Keep Pulling an end of yarn.

5. Hang a knitting weight or pull it down lightly by hand.

Continue knitting.

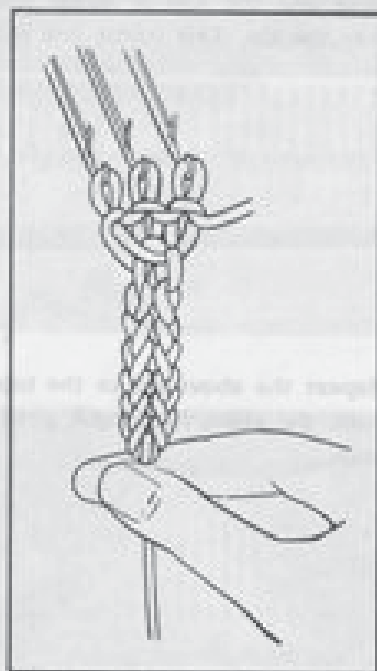

It is recommended to use a rather low tension for a neater finish.



## 10. HOW TO FIX THE MACHINE

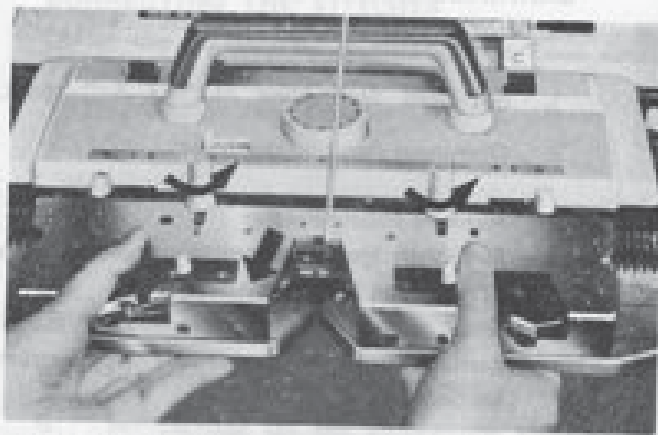

Front steel holder from end across left

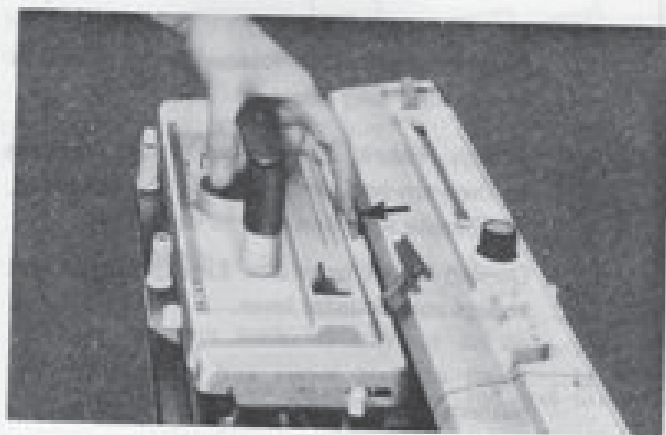
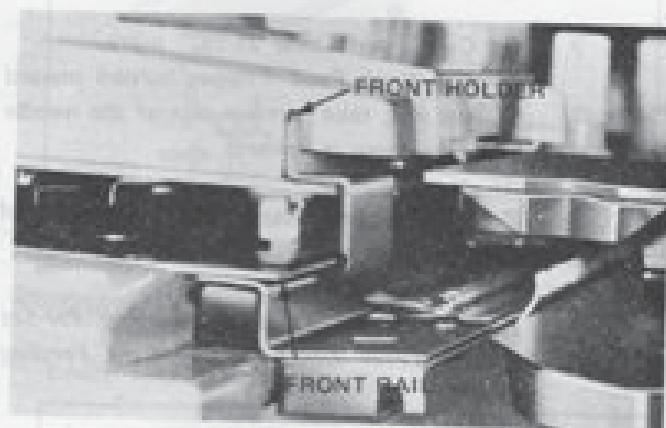
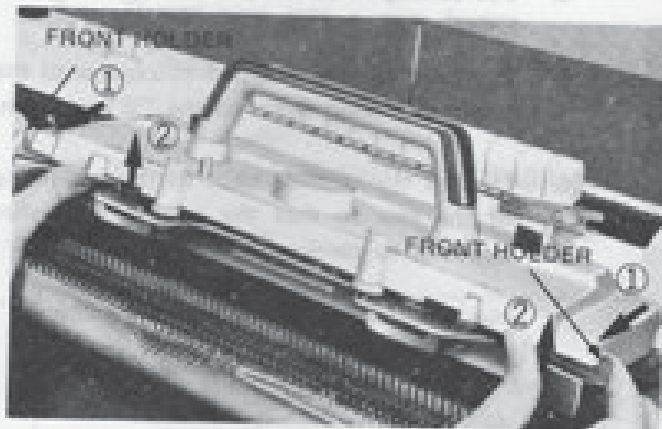

### CARRIAGE JAMMING IN PLAIN KNITTING

\* *Never move carriage by force.*

1. Loosen both F.P. knobs and remove Fabric Presser by pulling it upward.
2. Disengage row counter lever.
3. Pull both front holders, and still holding them, tilt carriage backwards. Then, slide it over the working section.
4. Tilt carriage back down, still holding both front holders.  
Fit the front holders onto the front rail.
5. Unravel stitches back to the beginning of the row.
6. Put back all the dropped stitches onto the hook and bring them to the "B" position.  
For picking up the dropped stitches, refer to pages 45 and 46.
7. If the end of yarn is on the side opposite the carriage, push Empty Button nearest to the yarn-end side, and shift carriage to the other side.  
Do not forget to release the Empty Button.
8. Attach Fabric Presser to carriage.  
Thread yarn into the yarn feeder.
9. Set row counter lever.
10. Fix row counter according to the number of unraveled rows.

## CARRIAGE JAMMING IN PUNCH KNITTING

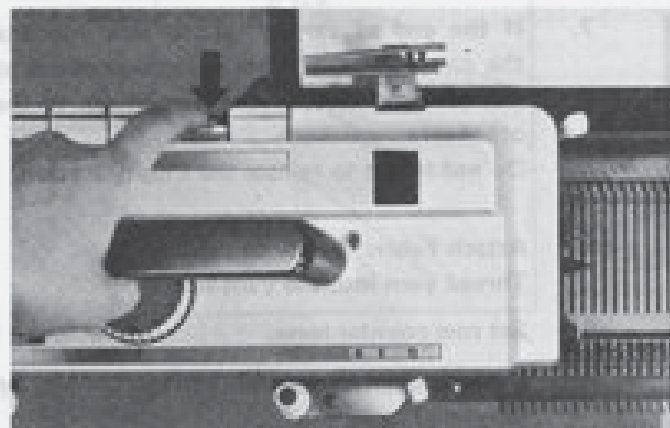
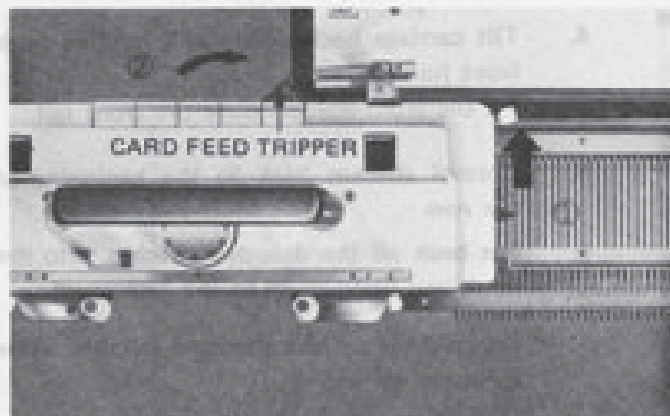
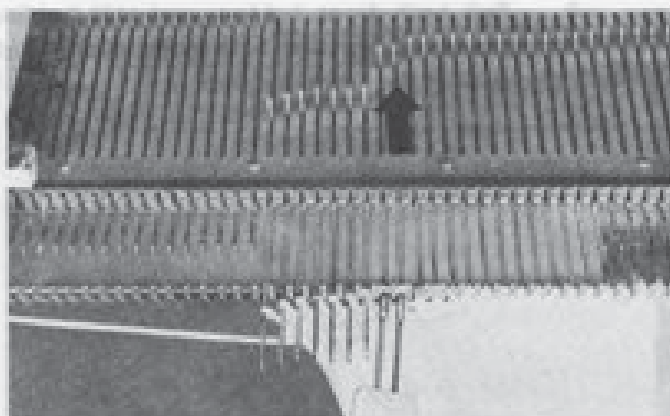
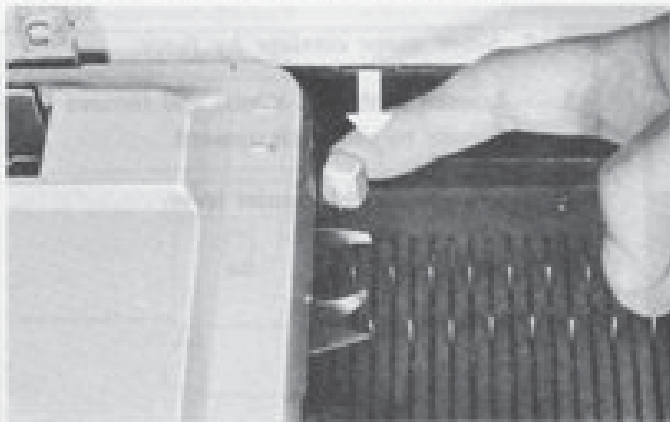
CARRIAGE JAMMING  
IN PUNCH CARD KNITTING

1. Set card feed lever at " □ " mark.
2. Disengage row counter lever.
3. Remove Fabric Presser. Pull both front holders, and holding them, tilt carriage backwards. Slide it toward the direction of moving carriage until it comes off the working section.
4. Tilt carriage back down holding both front holders.
5. Put back all the dropped stitches onto the hook and bring them to the "B" position.
6. Unravel the stitches back to the beginning of the row so that the yarn end finishes opposite to carriage.
  - \* *Make sure that all needles are in the "B" position.*
7. Set Card Feed Lever at "C" mark. Be sure Card Feed Tripper turned inward (if it is not, take carriage out of the needle bed, then turn it inward).
8. Turn back punch card with the number of undone rows plus one row more.
  - \* *Do not forget to keep engaging Pre-Set Clutch Lever while turning Card Feeding Dial.*
9. Push Empty Button located in the direction of the following row.
10. Attach Fabric Presser and slide carriage to the yarn-end side. (Card will be advanced, and needle selection will be done.) Do not forget to release Empty Button and engage row counter lever.
11. Reset carriage levers and buttons for the pattern being done, and thread yarn.

## CORRECTING THE STITCHES

(After the punch card is advanced for one row before carriage works over the fabric.)

1. Disengage row counter lever.
2. Undo the incorrect stitches so that the yarn end finishes opposite to carriage.
  - \* Make sure that all the needles are in "B" position.
3. Turn back the punch card the number of undone rows plus one row more.
4. Push Empty Button located in the direction of the following row. Remember to release Empty Button, and reset row counter and the lever.
5. Move carriage to the yarn-end side.
6. Set carriage for the appropriate knitting stitch.
7. Thread yarn into a yarn feeder.

## SETTING CARRIAGE ONTO EXTENSION RAIL

### MAIN CARRIAGE

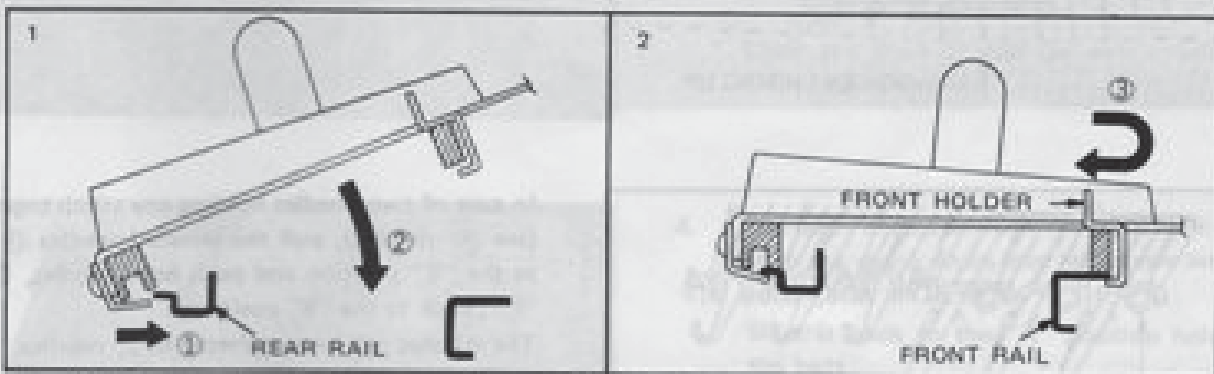

1. Put the back of carriage on the rear rail ① and tilt it down ②.
2. Pulling both front holders, and fit it onto the front rail ③.

### LACE CARRIAGE

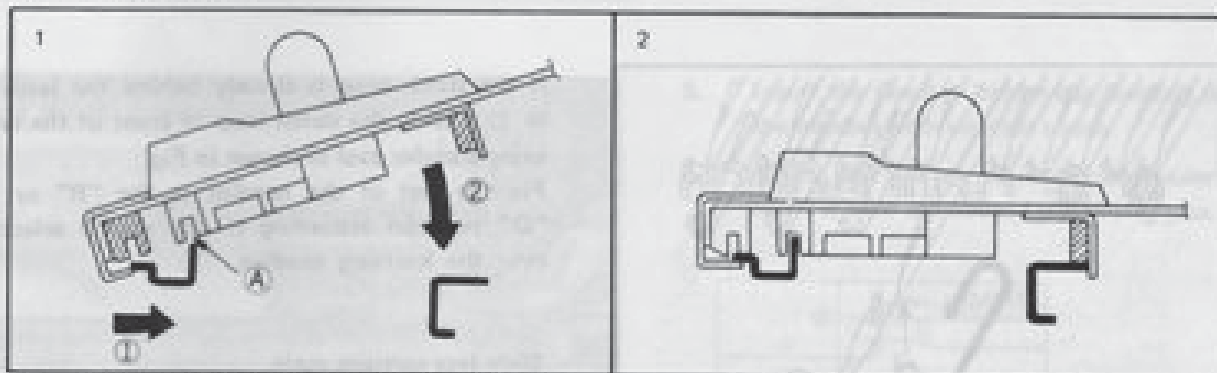

1. Put the back of carriage on the rear rail.
2. Fit a groove (A) in the rear rail and tilt it down.

## WHEN THE LACE CARRIAGE GETS STUCK WHILE KNITTING

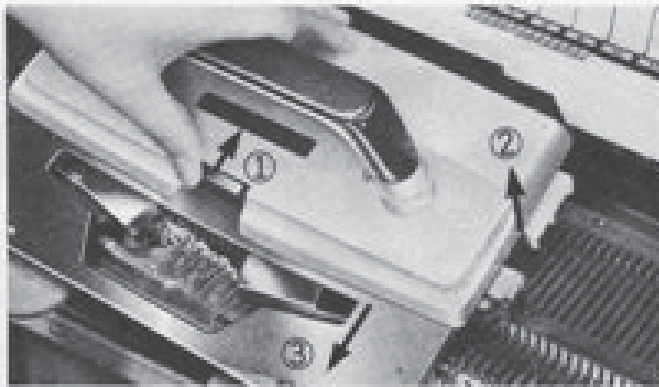

If the lace carriage jams, proceed as follows:

1. Push the Release Button in. ①
2. Lift the rear of the carriage upward. ②
3. Remove carriage from the bed by pulling it forward. ③
4. Place carriage back on its started position.

If there are any needles crossing each other, lift and unhook them.

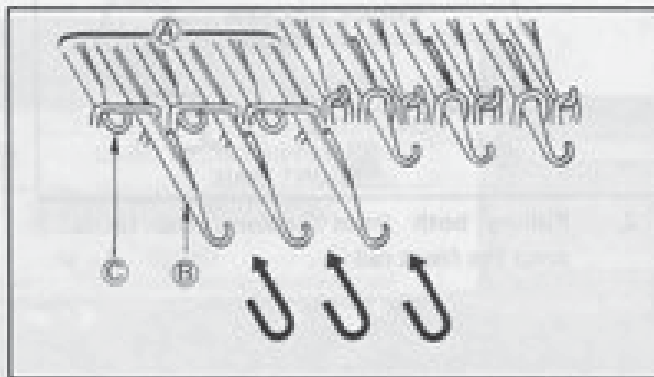
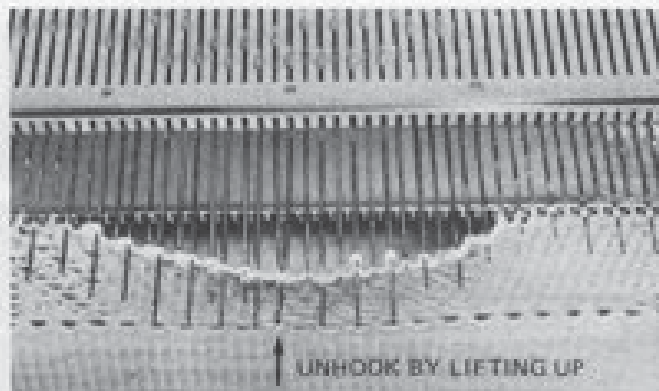

In case of two needles holding one stitch together (see ⑧ needles), pull the selected needles ⑧ out to the "E" position and push both needles, ⑨ & ⑩, back to the "B" position.

The stitches will be transferred to ⑩ needles.

\* If some needle-butts in the "D" position which are slightly going down, first push them to the "B" position, then bring them back to the "D" position.



If the stitch loop is already behind the latch as in ⑪, bring the stitch loop in front of the latch using transfer tool as shown in Fig.

Fix the rest of the needles to the "B" or the "D" position according to the needle selection over the knitting needles.

Slide lace carriage again.

## REPLACING THE NEEDLE

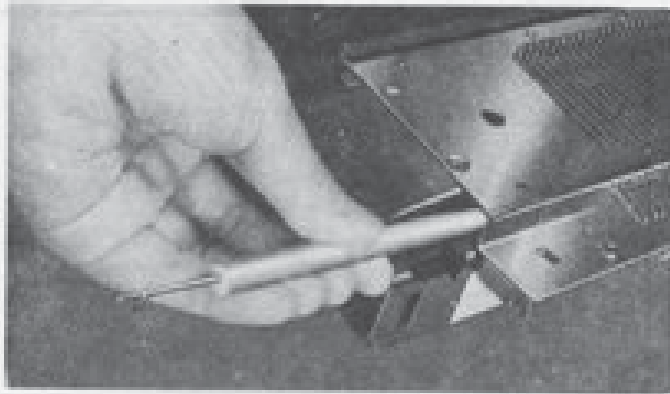

It is suggested to change the following needles if they are with.

- A bent butt
- A bent hook
- A latch that does not close freely.

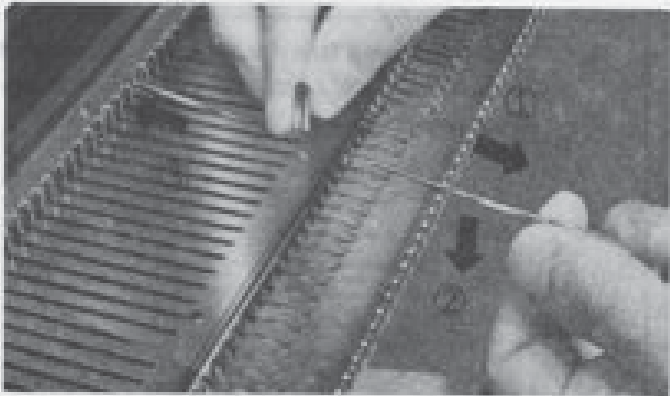

1. Insert the latch tool or anything like pencil using the flat end. Push in the tool from the either side of the needle bed until the bar (holding needles) comes out of the other side.
2. Pull out the bar until it disengages the damaged needle.
3. Hold the butt and slide it toward you ①. Hold the tip of the needle and push it down ② so the shank will come up. Holding the butt, slide needle back upward ③.

• Close the latch so that the needle will be easily taken out.

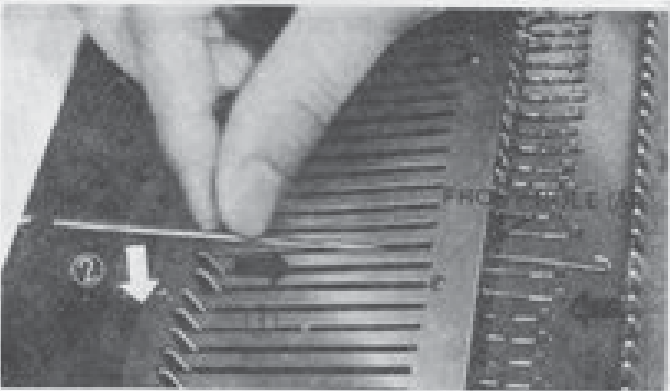

4. Slip spare needle through the front hole ④. Push the shank down into the groove on the needle bed. ①, ②, ③. Slide it back to the "A" position holding the butt.

• It will be easier to insert the needle with the latch opened.

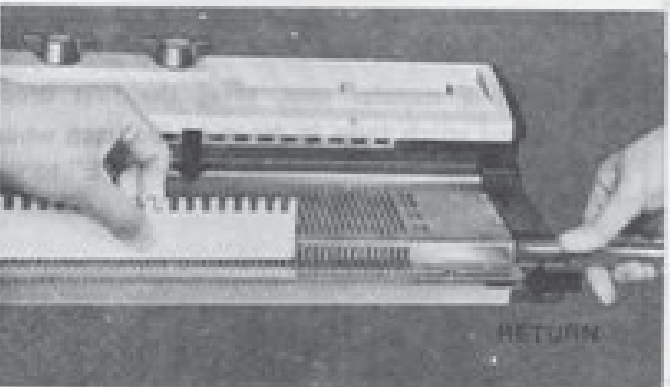

5. Insert the needle - holder bar, holding down the needles with selector comb.

• If you pull out the whole needle-holder bar, insert it with the dented side facing you.



## PICKING UP DROPPED STITCHES

### DROPPED ONE STITCH

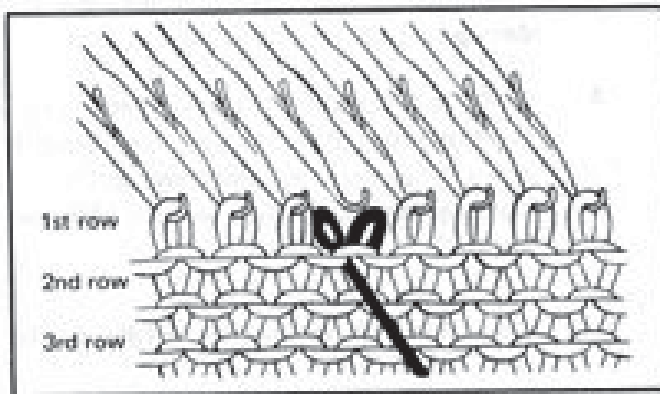
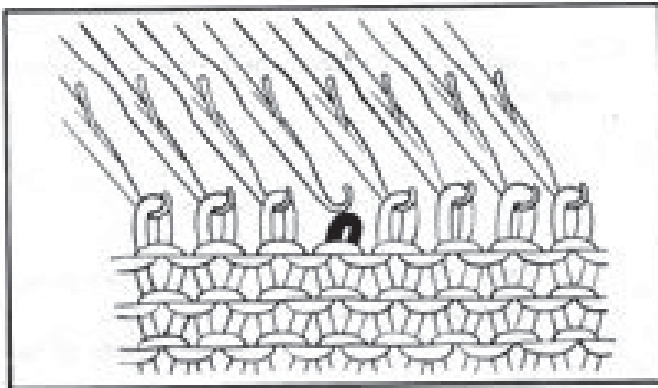

1. Insert one-eyed transfer tool into the second loop, then hook both loops onto the empty latch needle.

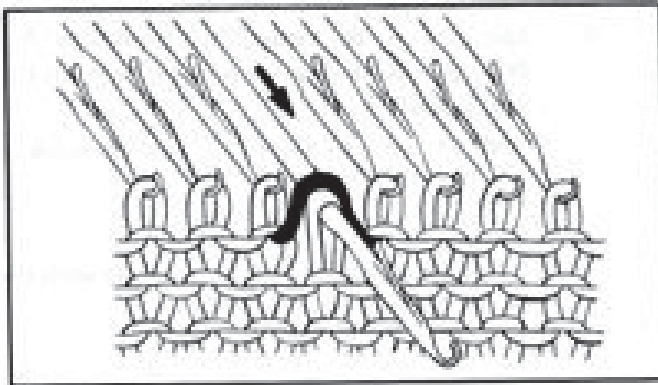

2. Pull the needle out to "E" position.

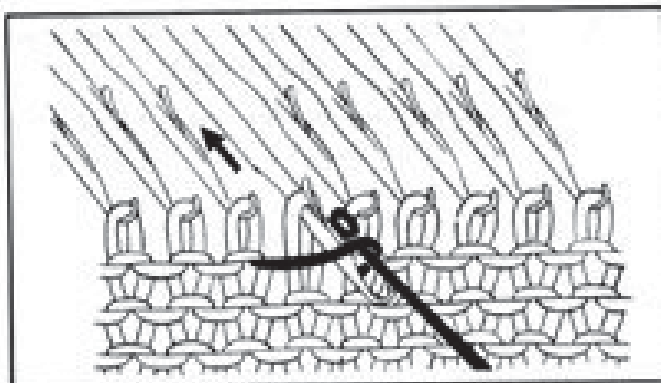

3. Using transfer tool, bring the first dropped stitch loop in front of the latch while pushing the needle back from the "E" to the "B" position.  
A stitch is formed.

HOW TO REPAIR A DROPPED STITCH

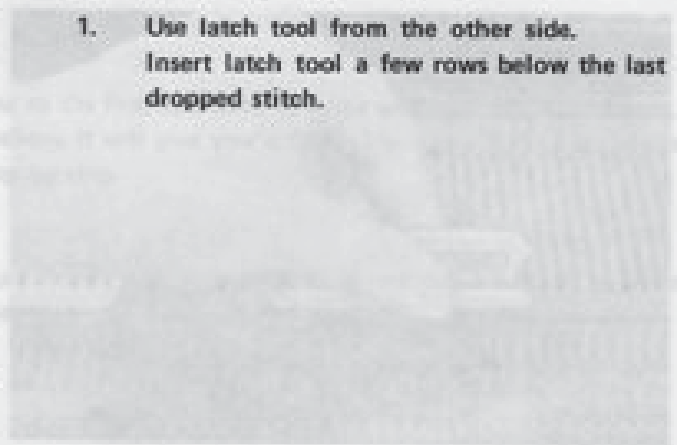
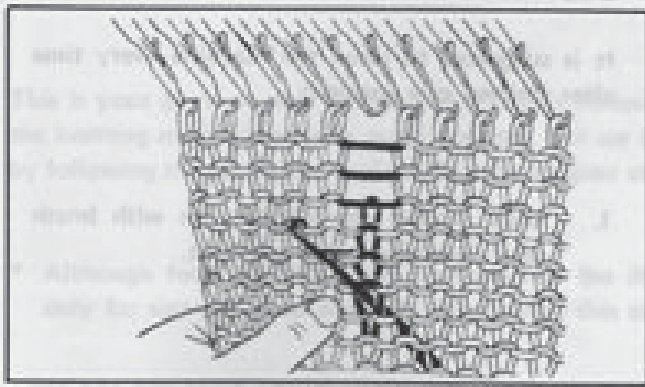

1. Use latch tool from the other side. Insert latch tool a few rows below the last dropped stitch.

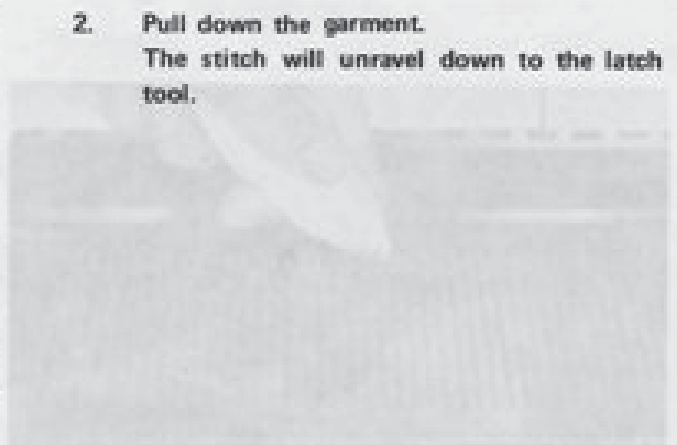
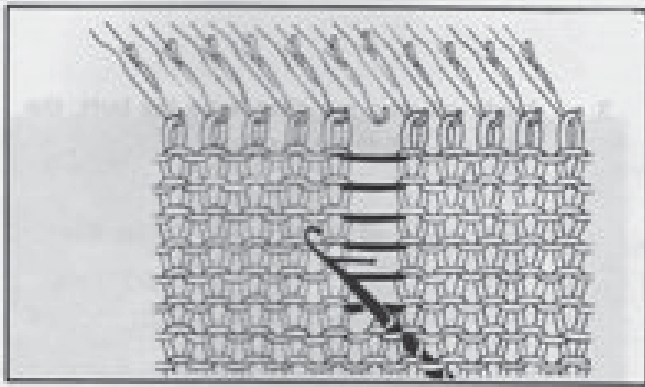

2. Pull down the garment. The stitch will unravel down to the latch tool.

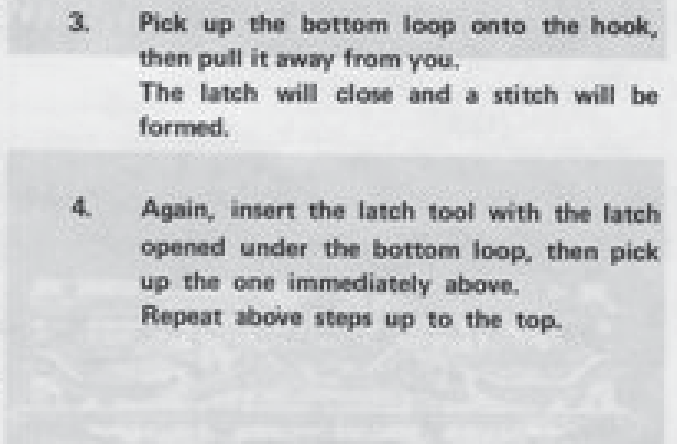
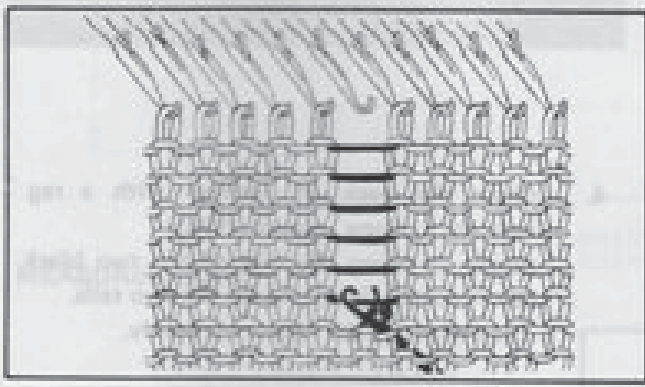

3. Pick up the bottom loop onto the hook, then pull it away from you. The latch will close and a stitch will be formed.

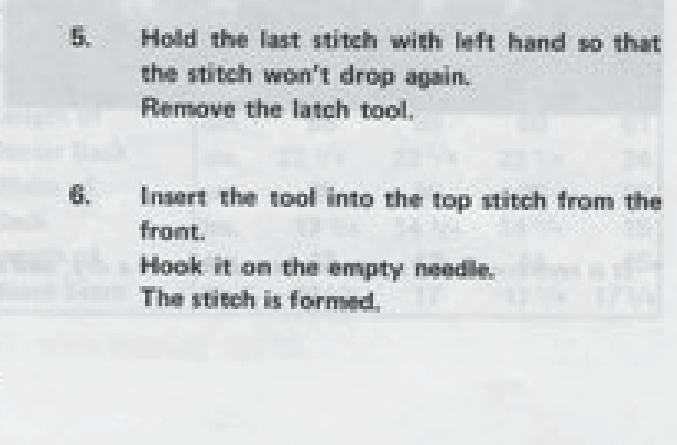
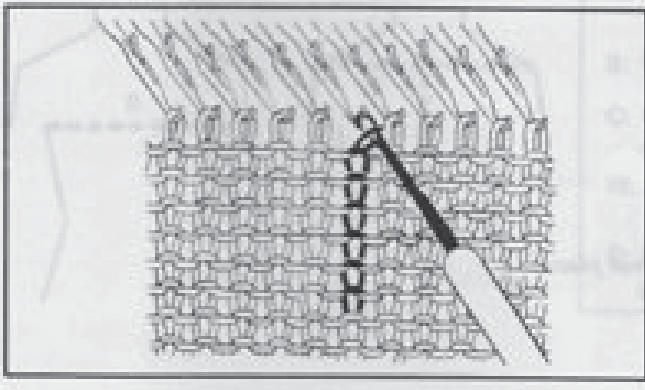

4. Again, insert the latch tool with the latch opened under the bottom loop, then pick up the one immediately above. Repeat above steps up to the top.
5. Hold the last stitch with left hand so that the stitch won't drop again. Remove the latch tool.
6. Insert the tool into the top stitch from the front. Hook it on the empty needle. The stitch is formed.



## 11. PROPER CARE OF THE MACHINE

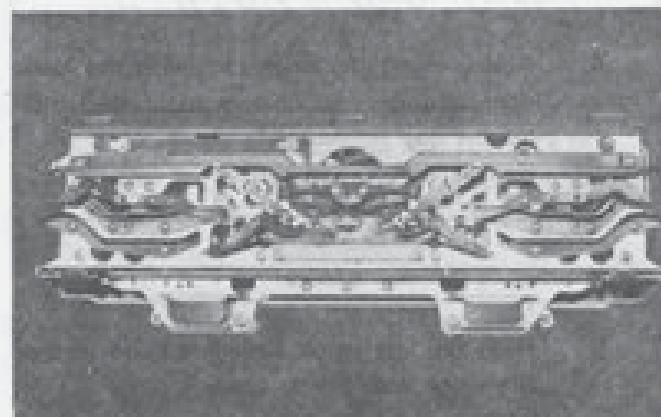
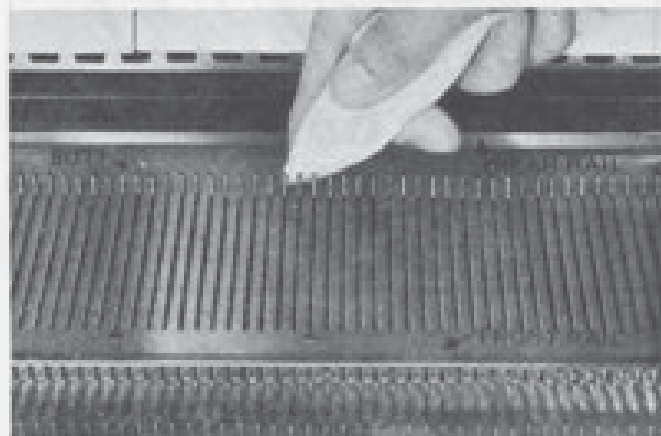
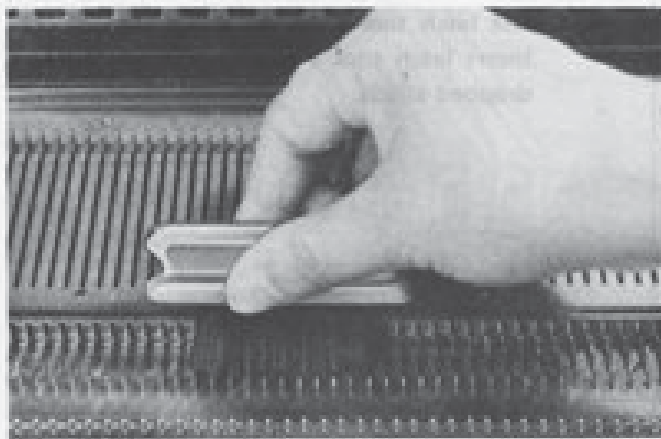

\* It is recommended to store the machine in a dry, and cool place.

## PROPER CARE OF DROPPED STITCHES

### DUSTING AND OILING

It is suggested to clean the machine every time after knitted one garment.

1. Dust around the plastic film with brush after finishing every garment.

2. Clean the rear rail, the front rail and the needle bed with a rag.

3. Apply oil on a rag, then wipe the butt, the front rail and the rear rail.

\* Never apply oil directly onto the needles.

4. Clean the back of carriage with a rag especially along plastic rails. Apply oil along the side of the two black cams (dotted lines) and on the two rails. Then wipe off the excess oil lightly.

## II KNITTING A SWEATER — LADY'S PULLOVER

ETHK3M3RUB23M

This is your guide to easy knitting of a Lady's Pullover as the first approach to make garments. Needless to say, the knitting method varies in every country, but we believe it will give you definite ideas how to knit garments by following the procedure explained in this chapter step by step.

- Although four different sizes are shown in the illustrations, the explanation for knitting a sweater is given only for size (A), as an example, throughout this chapter.



### MATERIALS:

Medium yarn . . . . . 7-10 balls of 50 gr.

### MEASUREMENTS:

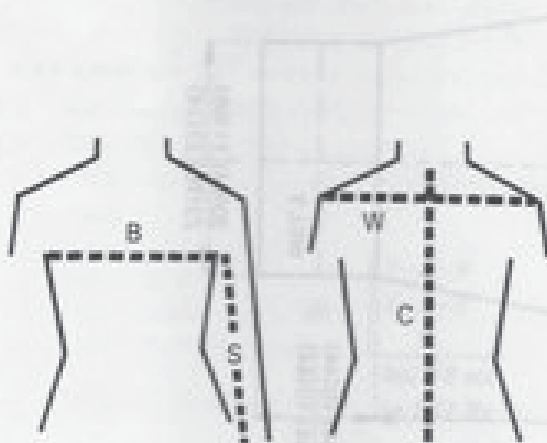

Size	(A) (B) (C) (D)				
	cm.	83	87	92	97
	ins.	32 1/2	34	36	38
B: Bust	cm.	86	90	95	100
	ins.	34	35 1/2	37 1/2	39 1/2
C: Length of Center Back	cm.	58	59	60	61
	ins.	22 3/4	23 1/4	23 1/2	24
W: Width of Back	cm.	35	36	36	38
	ins.	13 3/4	14 1/4	14 1/4	15
S: Length of Sleeve Seam	cm.	42	43	44	45
	ins.	16 1/2	17	17 1/4	17 3/4

**MEASUREMENTS**

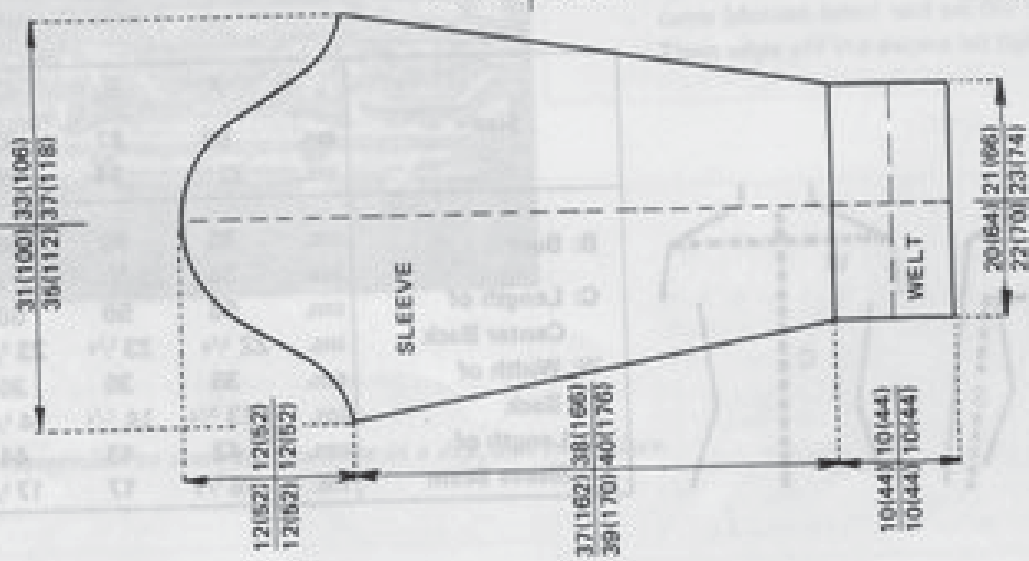
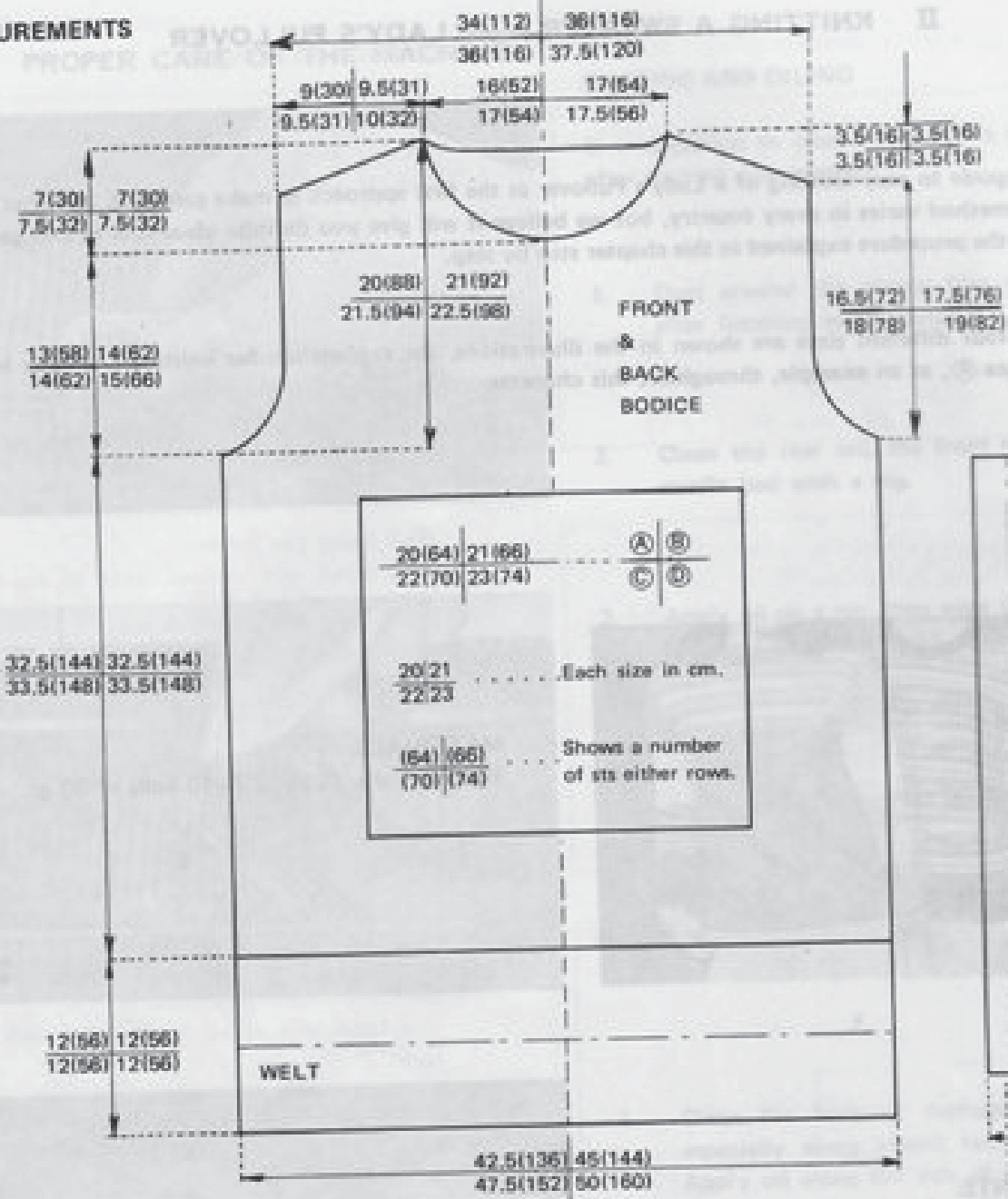

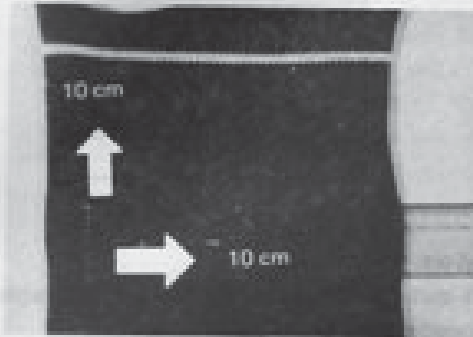
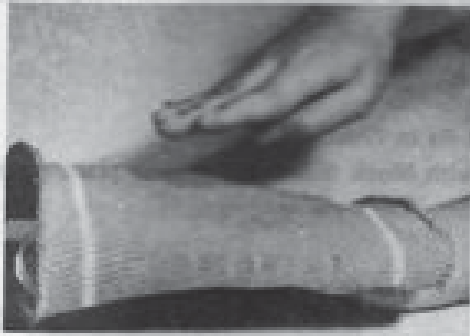

Tension Dial . . . . 4.2

(In case of using other type of yarn, refer to page 10).

10 cm Square . . . . 32 sts and 44 rows.  
(Medium Yarn)

\* Make a test piece about 60 sts x 60 rows by the yarn to be used with suitable Tension Dial (refer to page 10).

Pull the test piece lightly in lengthwise a few times and pat it lightly with your hand to restore it to the natural state.

The press it lightly with a steam iron. Count a number of the stitches and rows per 10 cm square.

**ABBREVIATIONS:**

St(s) . . . . . Stitch(es)  
Dec. . . . . Decrease  
Tens . . . . . Tension  
P.Kt . . . . . Partial Knitting  
12(14, 16, 18)sts . . . A number of stitches used for the respective size.

Rs(s) . . . . . Row (s)  
Inc . . . . . Increase  
W.Kt. . . . . Waste Knitting  
Illus . . . . . Illustration

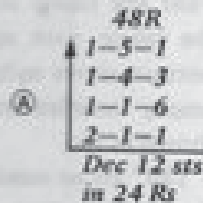

**Size ④**  
Start decreasing sts on each side, following the steps from the bottom to the top as shown by arrow mark ↑.  
Dec 2 sts and knit one R.  
Dec 1 st and knit one R. Repeat 6 times.  
Dec 1 st and knit 4 Rs. Repeat 3 times.  
Dec 1 st and knit 5 Rs.  
Thus, 12 sts decreased in total on each side while knitting 24 Rs altogether.  
Then knit 48 Rs more with straight plain stitch.

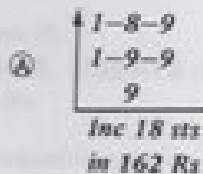

**Size ④**  
Knit 9 Rs with straight plain stitch.  
Start increasing sts on each side, following the steps from the bottom to the top as shown by arrow mark ↑.  
Inc 1 st and knit 9 Rs. Repeat 9 times.  
Inc 1 st and knit 8 Rs. Repeat 9 times.  
Thus 18 sts are increased in total on each side while knitting 162 Rs.

MEASUREMENTS  
**BACK**

**1. WELT (MOCK RIB)**

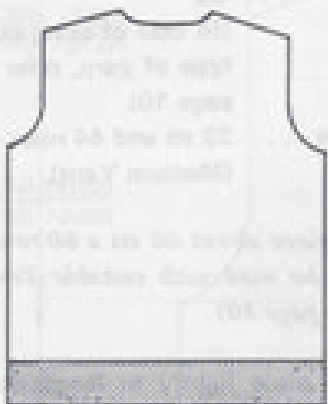

All sizes **A B C D**, 28 Rs in finished shape  
(55 Rs with Mock Rib and 1 R with plain stitch)

(For Ribber User . . . . . 1 x 1 Rib 28 Rs)

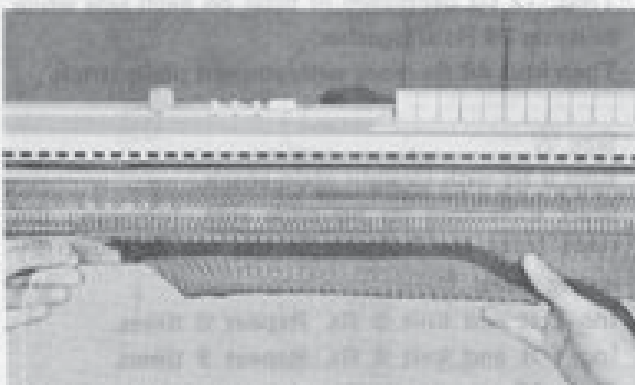
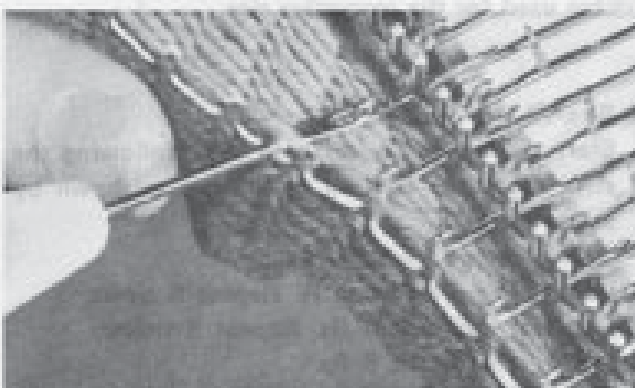
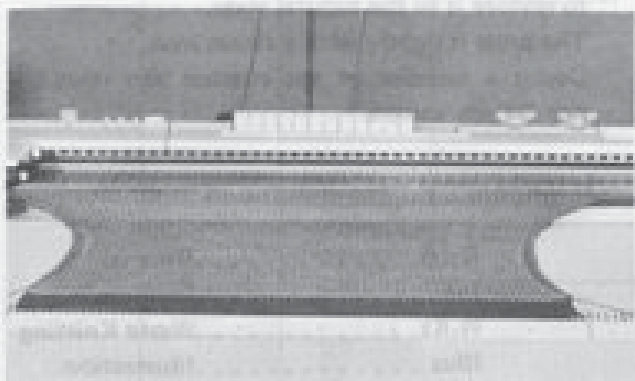

- (1) **Cast-on**  
Pull out 68 alternate needles on the center of needle bed, to "B" position.  
Thread waste yarn and knit about 10 Rs and remove the yarn from yarn feeder.  
Knit one row with nylon cord and remove it from yarn feeder.
- (2) **Set row counter at "0".**  
Knit 55 Rs with main yarn (see Fig.) with Tens Dial 2.2. (2 lower number than normal tension, refer to page 10).
- (3) **Pull out alternate needles remaining in "A" position to "B".**  
Fold the fabric in the middle, and holding the fabric, pick up main yarn loops at the bottom above nylon cord, onto the alternate empty needles by using transfer tool, as shown in Fig.  
("136" sts on needle bed).
- (4) **Reset Tens Dial at 4.2 for knitting plain stitch, and knit one row.**  
(Row counter at "56")
- (5) **Pull out nylon cord so that the waste knitting piece will drop. (See Fig.)**

Welt is completed.

## 2. BODICE (UP TO UNDER ARM POINT)

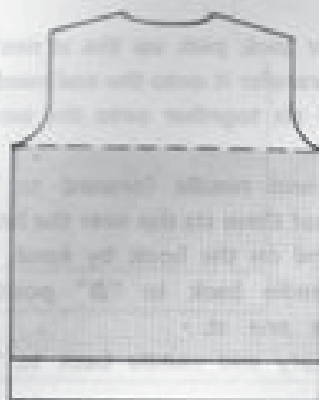

Size	Row No. of Body
A	144
B	144
C	148
D	148

- Set row counter at "0" Tens Dial . . . 4.2
- Knit plain stitch 144 Rs up to the bottom of the arm hole. (136 sts)

## 3. ARM HOLE

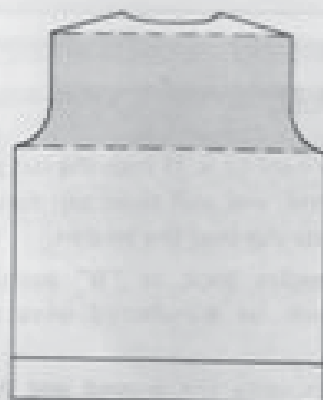

48R	50R	52R	54R
↑ 1-5-1	↑ 1-5-2	↑ 1-3-5	↑ 1-3-3
1-4-3	1-4-2	1-2-1	1-2-5
1-1-6	1-1-6	1-1-6	1-1-6
2-1-1	2-1-2	2-1-3	2-1-3
Dec 12 sts in 24 Rs	Dec 14 sts in 26 Rs	Dec 18 sts in 26 Rs	Dec 20 sts in 26 Rs

- Set row counter at "0".
- Start decreasing sts on each side .  
(For decreasing sts, refer to page 53, and follow steps from the bottom to the top as shown by the arrow mark ↑.)

Dec 2 sts and knit one R.  
Dec 1 st and knit one R. Repeat 6 times.  
Dec 1 st and knit 5 Rs.

Thus 12 sts are decreased in total on each side while knitting 24 Rs altogether.

- Then knit more 48 Rs with straight plain stitch up to the beginning of shoulder, Row Counter "72". (112 sts)

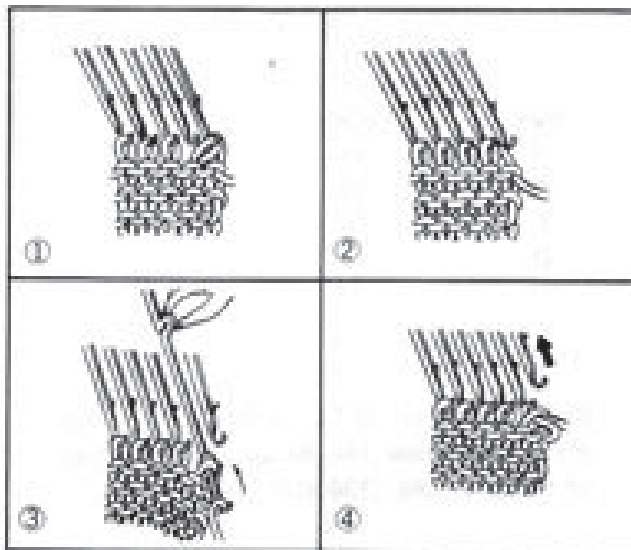

**DECREASING MANY STS (MORE THAN TWO)  
— CASTING-OFF —**

- (1) Using transfer tool, pick up the st next to the end and transfer it onto the end needle.
- (2) Transfer two sts together onto the second needle.  
Pull the second needle forward to "E" position so that these sts slip over the latch.
- (3) Wind yarn end on the hook by hand, and push the needle back to "B" position, which makes one st.
- (4) Push the empty end needle back to "A" position.

By repeating the above procedures from (1) through (4), required number of sts can be decreased.

To cast-off, repeat the above procedures over the row.

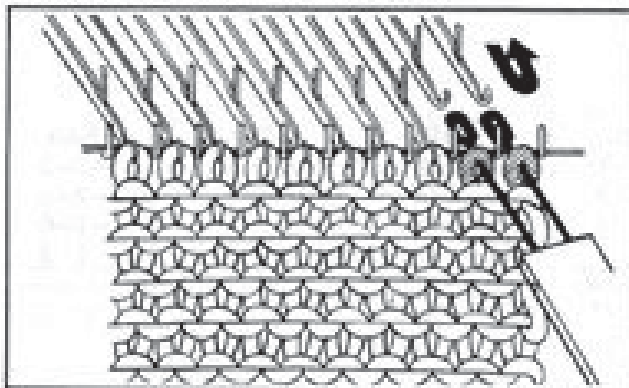

**DECREASING ONE ST**

- (1) Insert transfer tool (2 x 1) into the last two sts from the end, and pull them out toward you until the sts slip over the latches.
- (2) Push both needles back to "B" position so that sts will be transferred onto the tool.
- (3) Hook both sts onto the second and third needle as shown in Fig.
- (4) Push the empty end needle back to "A" position.

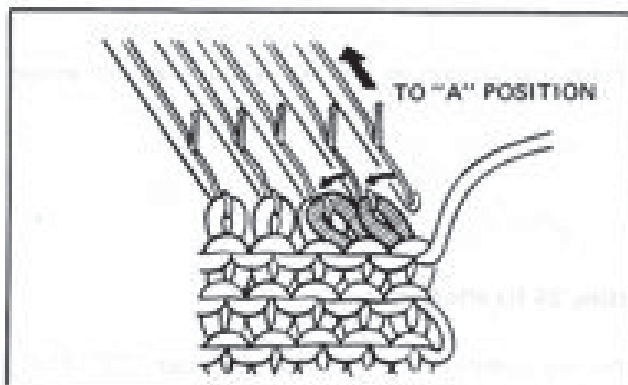

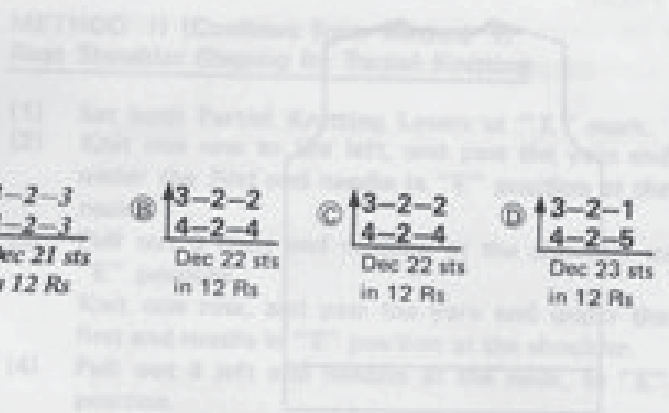
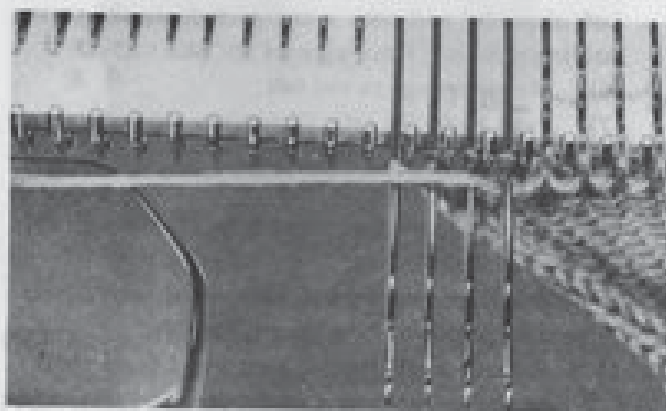
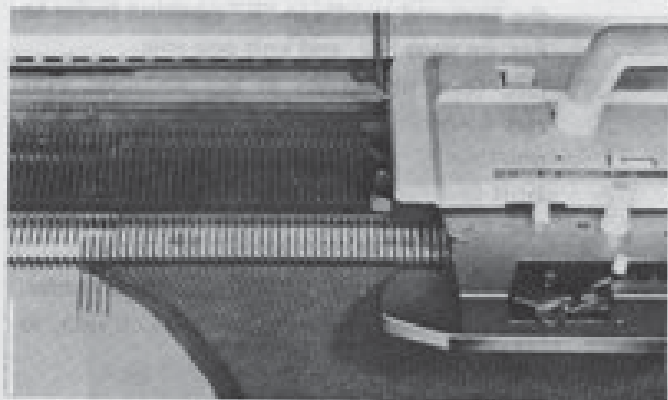
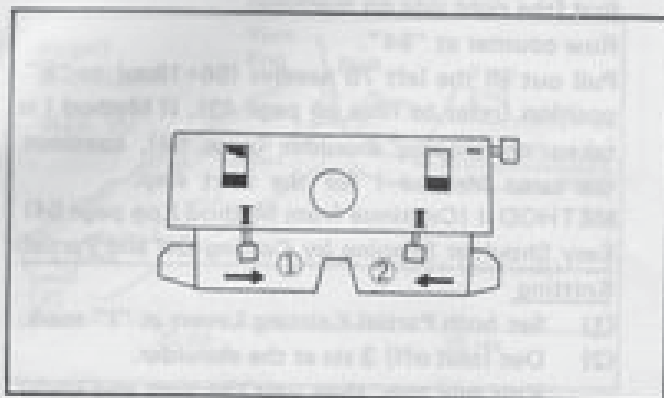
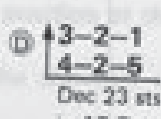
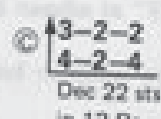
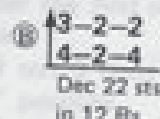
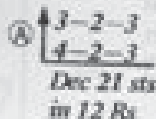
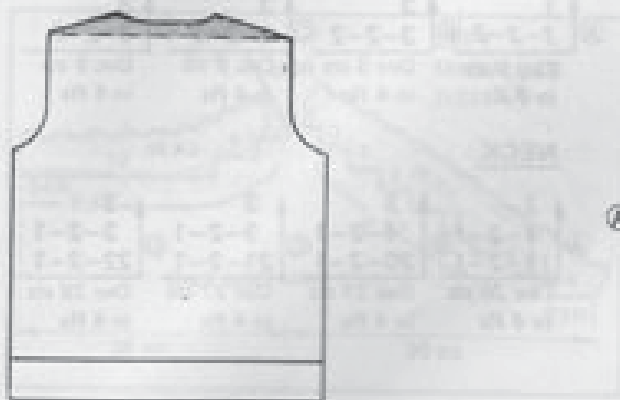

Row counter is at "72".  
Shape both shoulders up to the bottom of neck, "84".

**METHOD I**

Easy Shoulder Shaping by Casting Off  
(Decreasing Many Sts)

Dec sts on each side, following the steps shown in above illus.

- (1) Dec 4 sts at the side of yarn end, and knit 2 Rs. Repeat 3 times.
- (2) Dec 3 sts and knit 2 Rs. Repeat 3 times.

**METHOD II**

Neat Shoulder Shaping by Partial Knitting (Hold-  
ing Position)

- (1) Set both Partial Knitting Levers at "1" mark.
- (2) Pull out needles to be decreased, opposite side to carriage, to "E" position. (See Fig.)
- (3) Knit one row.
- (4) Pass the yarn end under the first end "E" position needle by hand. (See Fig.) — This avoids a hole showing on the fabric.
- (5) Repeat above steps from (2) through (4) at each end in every row up to the bottom of neck, "84" Rs.  
— There will be 21 needles in "E" position on each side.



## 5. SHAPING R-NECK & SHOULDER

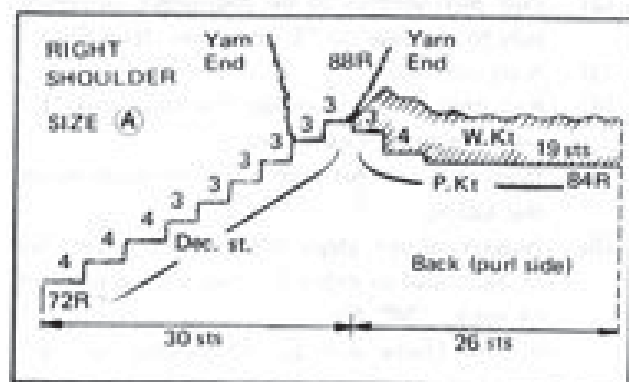
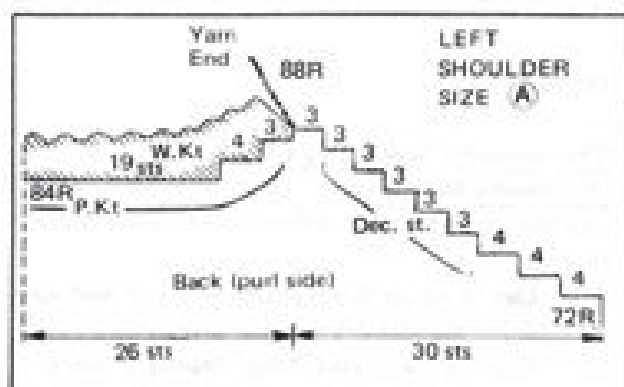
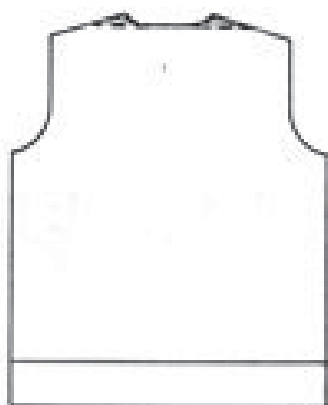

### SHOULDER

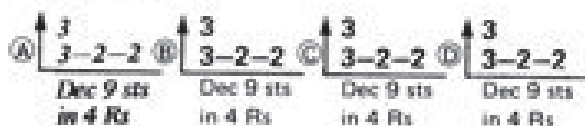

### NECK

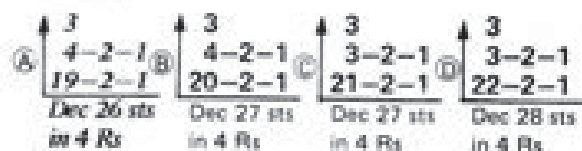

Carriage is on the right, so complete left shoulder first (the right side on machine).

Row counter at "84".

Pull out all the left 75 needles (56+19sts) to "E" position (refer to illus on page 49). If Method I is taken on shaping shoulder (page 54), continue the same Method I for the next step.

**METHOD I (Continue from Method I on page 54)**  
**Easy Shoulder Shaping by Casting Off and Partial Knitting**

- (1) Set both Partial Knitting Levers at "1" mark.
- (2) Dec (cast off) 3 sts at the shoulder. Knit one row, then pass the yarn end under the first end needle in "E" position (refer to Fig. on page 54), and knit one row.
- (3) Dec (cast off) 3 sts at the shoulder. Pull out 4 needles adjacent to neck side, to "E" position. Knit one row, then pass the yarn end under the first end needle in "E" position, and knit one row.
- (4) Dec (cast off) the last 3 sts at the shoulder. Pull out 3 needles adjacent to neck side, to "E" position.
- (5) Remove yarn and cut it.

Left shoulder and neck is completed with 82 sts in holding position. Row counter at "88".

- (6) Move carriage to the left.
- (7) Push back the left 37 needles (30 + 7 sts) to "D" position.
- (8) Set row counter at "84".
- (9) Repeat the above steps from (2) through (5) over the left side.

Right shoulder and neck is completed with 52 sts in holding position. Row counter at "88".

- (10) Release both Partial Knitting Levers to "0" mark, and thread a waste yarn and do waste knitting for 52 sts about 10 rows.
- (11) Remove the piece from machine.

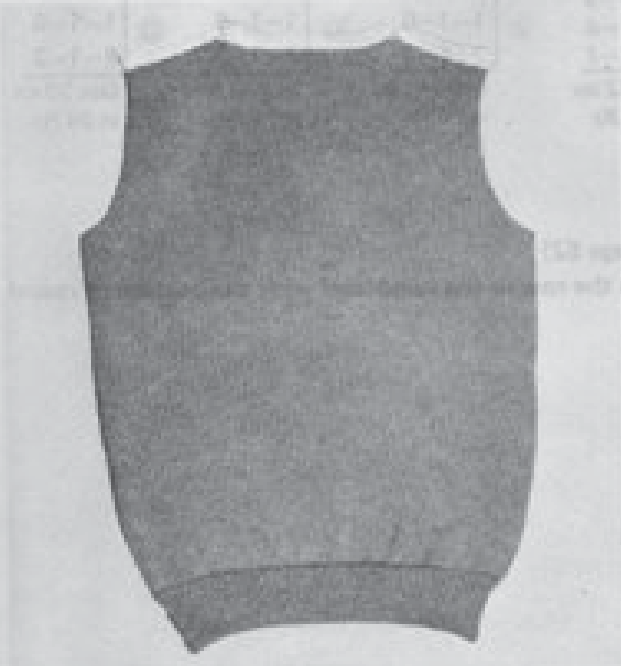
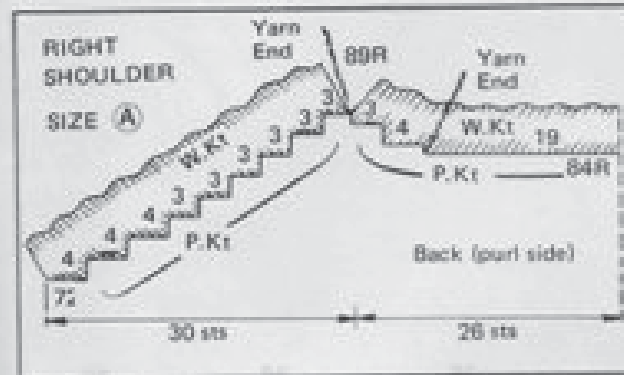
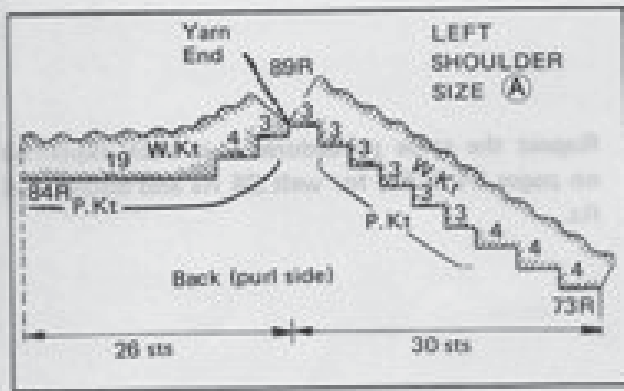

**METHOD II (Continue from Method I)**  
**Neat Shoulder Shaping by Partial Knitting**

- (1) Set both Partial Knitting Levers at "I" mark.
- (2) Knit one row to the left, and pass the yarn end under the first end needle in "E" position at the neck.
- (3) Pull out 3 right end needles, at the shoulder to "E" position.  
 Knit one row, and pass the yarn end under the first end needle in "E" position at the shoulder.
- (4) Pull out 4 left end needles at the neck, to "E" position.  
 Knit one row, and pass the yarn end as above.
- (5) Pull out 3 right end needles at the shoulder, to "E" position.  
 Knit one row, and pass the yarn end as above.
- (6) Pull out 3 left end needles at the neck, to "E" position.  
 Knit one row, leaving carriage on the center, and pass the yarn end as above.
- (7) Pull out remaining 3 needles to "E" position.
- (8) Remove the yarn and cut it.  
 Left shoulder and neck is completed. Row counter at "89".
- (9) Push back 16 needles (from 20th through 35th needle from the center) to "D" position.
- (10) Set row counter at "84".
- (11) Knit one row to the left, and pass the yarn end as above.
- (12) Pull out 4 right end needles at the neck, to "E" position.  
 Knit one row, and pass the yarn end as above.
- (13) Pull out 3 left end needles at the shoulder, to "E" position.  
 Knit one row, and pass the yarn end as above.
- (14) Pull out 3 right end needles at the neck, to "E" position.  
 Knit one row, and pass the yarn end as above.
- (15) Pull out 3 left end needles at the shoulder, to "E" position.  
 Knit one row, and pass the yarn end as above.
- (16) Pull out remaining 3 needles to "E" position, and remove the yarn and cut it.  
 Right shoulder and neck is completed. Row counter at "89".
- (17) Push back 30 left end needles at the shoulder, to "D" position.  
 Thread a waste yarn and do waste knitting about 10 Rs.  
 Remove the waste yarn and slide carriage to drop waste knitting.  
 Push back the empty needles to "A" position.

- (18) Repeat the same step as (16) for 52 center needles at neck for waste knitting.
- (19) Repeat the same step as (16) for 30 right end needles at the shoulder.

Back is completed.

**FRONT**

**1. WELT AND BODICE**

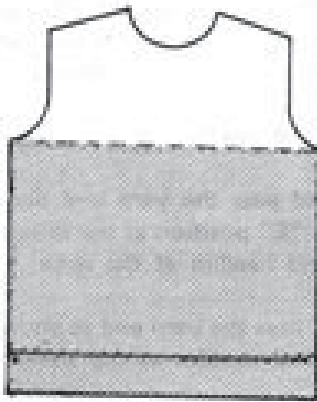

Repeat the same procedures as in back explained on pages 51 & 52, for welt 28 Rs and bodice 144 Rs.

**2. ARM HOLE**

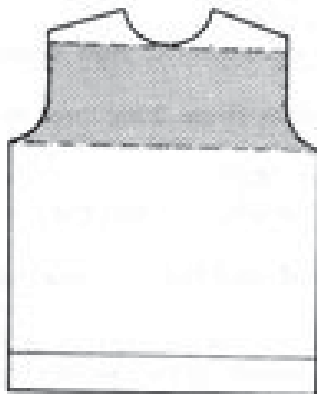

<p>34  <math>\begin{array}{l} \uparrow 1-5-1 \\ 1-4-3 \\ 1-1-6 \\ 2-1-1 \end{array}</math>                  Dec 12 sts                  in 24 Rs</p>	<p>36  <math>\begin{array}{l} \uparrow 1-5-2 \\ 1-4-2 \\ 1-1-6 \\ 2-1-2 \end{array}</math>                  Dec 14 sts                  in 26 Rs</p>	<p>36  <math>\begin{array}{l} \uparrow 1-3-5 \\ 1-2-1 \\ 1-1-6 \\ 2-1-3 \end{array}</math>                  Dec 18 sts                  in 26 Rs</p>	<p>38  <math>\begin{array}{l} \uparrow 1-3-3 \\ 1-2-5 \\ 1-1-6 \\ 2-1-3 \end{array}</math>                  Dec 20 sts                  in 28 Rs</p>
--	--	--	--

- (1) Repeat the same steps as (1) & (2) of back. (Refer to page 52)
- (2) Then knit 34 Rs more with straight plain stitch up to the row in the same level with the bottom of round neck. Row counter at "58".

**3. ROUND NECK (RIGHT)**

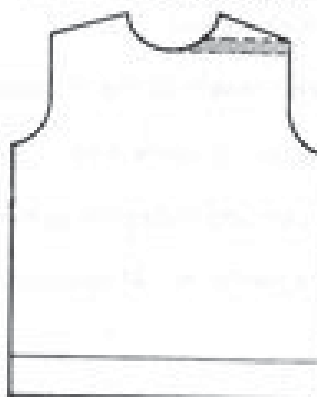

<p>Ⓐ <math>\begin{array}{l} \uparrow 1-2-2 \\ 3-2-4 \\ 7-2-1 \end{array}</math>                  Dec 21 sts                  in 14 Rs</p>	<p>Ⓑ <math>\begin{array}{l} \uparrow 1-2-2 \\ 3-2-4 \\ 7-2-1 \end{array}</math>                  Dec 21 sts                  in 14 Rs</p>	<p>Ⓒ <math>\begin{array}{l} \uparrow 1-3-2 \\ 3-2-4 \\ 7-2-1 \end{array}</math>                  Dec 21 sts                  in 16 Rs</p>	<p>Ⓓ <math>\begin{array}{l} \uparrow 1-3-2 \\ 3-2-4 \\ 8-2-1 \end{array}</math>                  Dec 22 sts                  in 16 Rs</p>
---	---	---	---

**METHOD II**

**SHAPING  
SHOULDER**

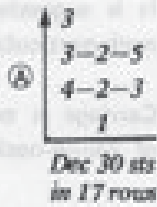

**SHAPING  
ROUND  
NECK**

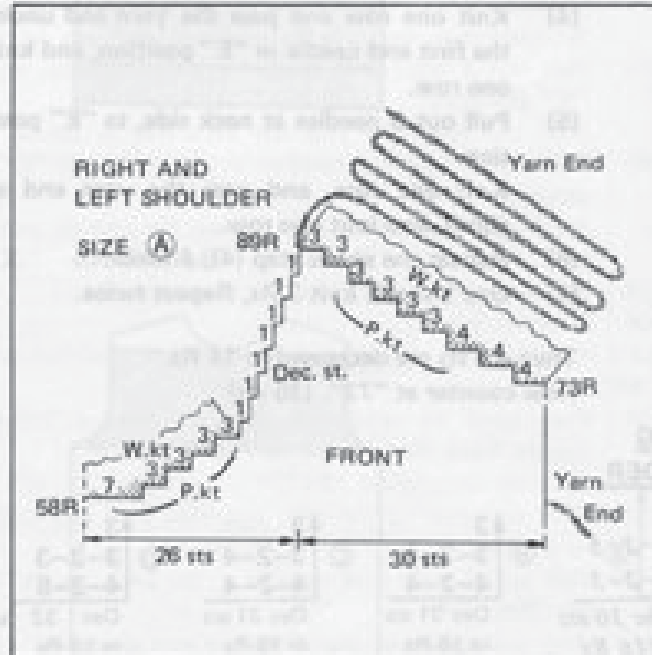
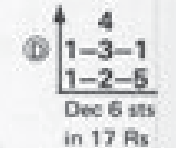
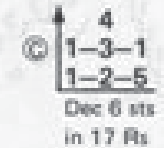
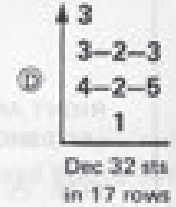
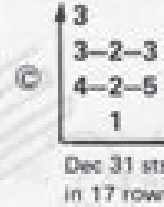
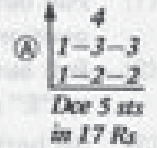

**Method II**

**Neat Shaping by Partial Knitting (shoulder)  
and Decreasing (neck)**

- (1) Set both Partial Knitting Levers at "I" mark.
- (2) Knit one row to the left. Row counter at "73".

Do partial knitting at the shoulder referring to page 54, and dec sts at the neck at the same time following Fig. up to row counter at "89".

\* After shaping a shoulder and a neck, leave a yarn end about 70cm (27 1/2") at the neck side and cut it.

Finish the right shoulder (30 sts) with 10 Rs of the waste knitting and take it off.

The right shoulder is completed.

Put carriage on the left side off the work.

Bring the center 14 needles and the remaining 12 needles on the left to "E" position.

Set row counter at "58".

Thread a main yarn and shape the left neck and shoulder following the same procedure as the right side.

\* Leave about 70cm (27 1/2") of yarn end and remove it.

Take off the center neck "38" sts and the left shoulder 30 sts with the waste knitting separately.

FRONT is completed.



## SLEEVES

### 1. BAND AND SLEEVE



#### BAND

All sizes (A) (B) (C) (D), 22 Rs in finished shape  
 (43 Rs with Mock Rib and 1 R with plain stitch)  
 (For Ribber User . . . . . 1 x 1 Rib, 22 Rs)

#### SLEEVE

(A) $\begin{array}{l} \uparrow 1-8-9 \\ 1-9-9 \\ 9 \end{array}$ Inc 18 sts in 162 Rs	(B) $\begin{array}{l} \uparrow 1-7-2 \\ 1-8-18 \\ 8 \end{array}$ Inc 20 sts in 166 Rs	(C) $\begin{array}{l} \uparrow 1-7-6 \\ 1-8-15 \\ 8 \end{array}$ Inc 21 sts in 170 Rs	(D) $\begin{array}{l} \uparrow 1-7-8 \\ 1-8-14 \\ 8 \end{array}$ Inc 22 sts in 176 Rs
--	---	---	---

(Follow steps from the bottom to the top as shown by the arrow mark ↑ )

- (1) With 32 alternate needles pulled out to "B" position, cast on and knit 43 Rs with Tens Dial 2.2 to make double folded Mock Rib in the same way as for back, referring to page 51, from (1) through (3). ("64" sts on needle bed)
- (2) Reset Tens Dial at 4.2 for knitting plain stitch, and knit one row and pull out nylon cord so that the waste knitting piece will drop off. (Row counter at "44")
- (3) Set row counter at "0".
- (4) Knit 9 Rs with straight plain stitch.
- (5) Start increasing sts on each side.  
 (For increasing sts, refer to the instruction below).  
 Inc 1 st and knit 9 Rs. Repeat 9 times.  
 Inc 1 st and knit 8 Rs. Repeat 9 times.  
 Thus 18 sts are increased in total on each side while knitting 162 Rs.  
 (Row counter at "162", and 100 sts on needle bed).

#### HINT FOR MAKING GARMENT – HOW TO INCREASE STS

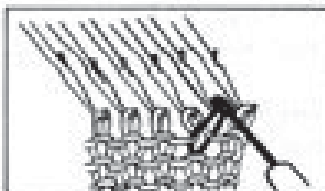
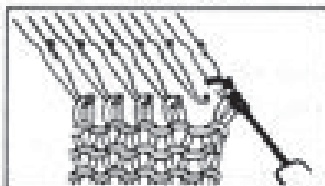
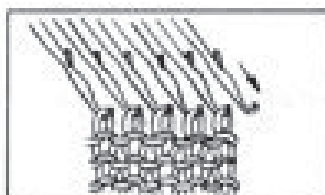

#### Increasing one st

- (1) Pull out the empty needle adjacent to the working needles to "B" position.
- (2) Transfer the first end st to the empty needle pulled out, with transfer tool.
- (3) Pick up the second end st loop on the previous row and hook it on the empty needle as shown in Fig.

### 3. TOP SLEEVE SHAPING

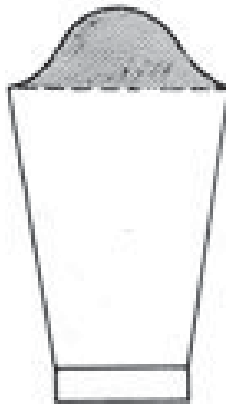

#### TOP OF THE SLEEVE

↑ 1 2-1-4 1-1-6 1-2-16 1-1-6 2-1-4 Dec 44 sts in 52 Rs	↑ 1 2-1-5 1-1-5 1-2-16 1-1-5 2-1-5 Dec 46 sts in 52 Rs	↑ 1 2-1-5 1-1-7 1-2-14 1-1-7 2-1-5 Dec 48 sts in 52 Rs	↑ 1 2-1-6 1-1-6 1-2-14 1-1-6 2-1-6 Dec 50 sts in 52 Rs
---	---	---	---

(Follow steps from the bottom to the top as shown by the arrow mark ↑ )

- (1) Set row counter at "0".
- (2) Start decreasing sts on each side.  
(For decreasing sts, refer to the instruction on page 53)  
Dec 2 sts and knit one row. Repeat 4 times.  
Dec 1 st and knit one row. Repeat 6 times.  
Dec 1 st and knit 2 Rs. Repeat 16 times.  
Dec 1st and knit one row. Repeat 6 times.  
Dec 2 sts and knit one row. Repeat 4 times.  
Thus 44 sts decreased in total on each side while knitting 52 Rs.  
(~12" sts left on needle bed)
- (3) Cast off the remaining sts.  
(For casting off, refer to the instruction on page 53)

One of sleeves is completed.

Follow the same procedures for the other sleeve.

#### HINT FOR MAKING GARMENT – HOW TO INCREASE STS

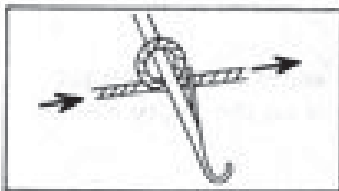
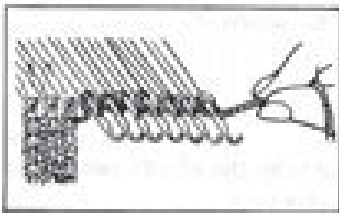

#### Increasing many sts (Sealed-edge, Winding Cast on)

- \* Follow the steps below at yarn end side.
- (1) Pull out required number of empty needles adjacent to the working needles, to "E" position.
  - (2) Wind yarn end around each empty needle by passing it under needle and over the top.
  - (3) Thread the yarn and knit one row, holding yarn end.
  - (4) Knit several rows, pulling out the needles to "E" position in every row knitted.

## TO MAKE UP

Apply a steam iron and fix the shape of **FRONT**, **BACK** and **SLEEVES** before seaming them.

There are two ways to knit neck band;

- (a) Knitting Neck Band continuously by picking up sts of neck of Front and Back bodice.
- (b) Knitting Neck Band separately and seam it afterwards.

Here we will go through Method (a), which will make the neck elastic enough to wear easily and comfortably. Seam one of shoulders (right) first.

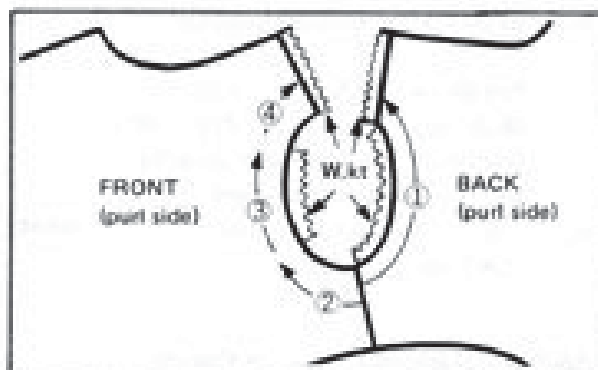
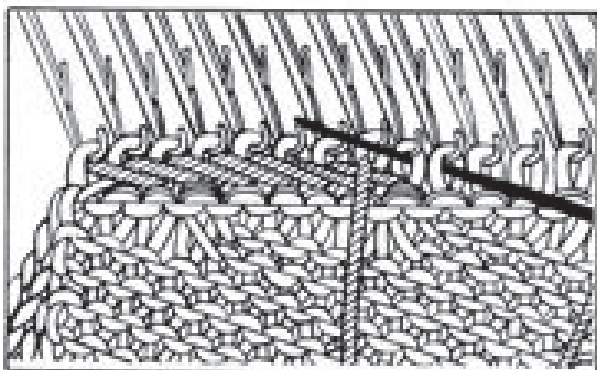
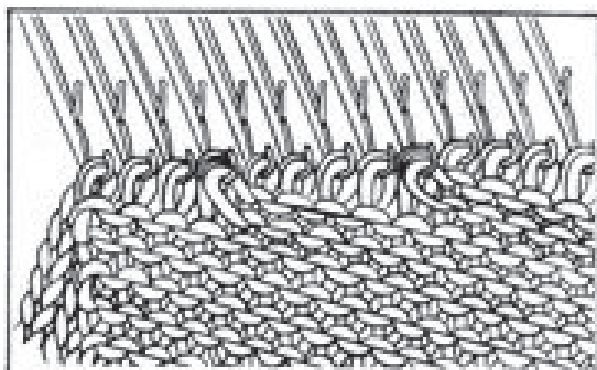

### 1. RIGHT SHOULDER SEAMING (GRAFTING)

- (1) Pick up the right shoulder's sts (30) of **FRONT** onto the machine with the right stitch faced toward you.
- (2) Put the right shoulder's sts (30) of **BACK** onto the same needles with the purl stitch faced toward you.
- (3) Remove the waste knittings.  
The yarn end of **FRONT** is at the right side.
- (4) Thread the yarn end into the yarn feeder.
- (5) Set Tens Dial to knit plain stitch, and knit one row to the left.
- (6) Remove yarn from the yarn feeder.
- (7) Use a tapestry needle with the end of yarn, graft the stitches as shown in Fig.

### 2. NECK BAND

#### Plain Doubled Neck Band

- (1) With purl side faced toward you, pick up all the sts along the back neck, starting with the first st at right shoulder seaming, onto the needles from the center to the right.
  - \* Do not pick-up the sts of the left shoulder yet.
- (2) To make up the right side of front neck with sts without waste knitting, (area shown by ② in Fig), pick up only three consecutive sts, dropping one st (see Fig. on page 63), onto the needles from the center to the left.

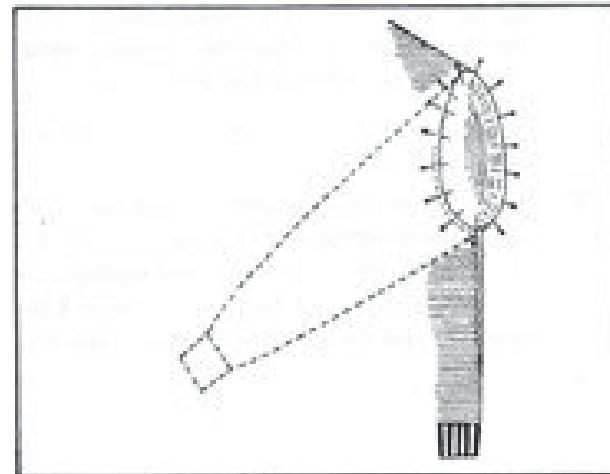
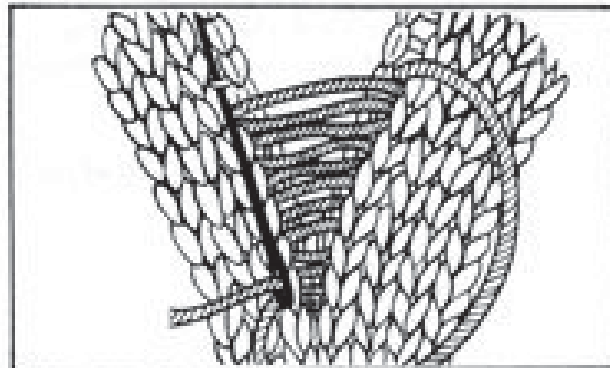
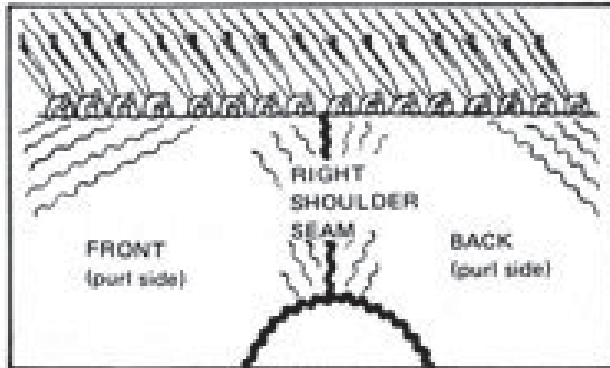
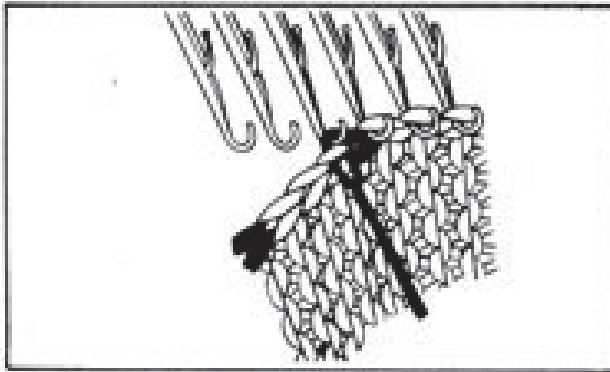

- (3) Then pick up all the sts along the middle part of front neck, onto the needles.
- (4) Pick up sts on the left side of front neck (area shown by ④ in Fig on page 62) onto the needles in same way as step (2).

124 (130, 132, 134) sts will be on the needles altogether.

- (5) Increase one st at each end for seaming.
- (6) Knit 26 Rs and do the waste knitting.
- (7) Remove the waste knitting in the area shown by ① & ③ in Fig on page 62, and fold the neck band in the middle and sew it with a tapestry needle in a form of plain stitch.
- (8) Remove the waste knitting made in (6).

#### FOR RIBBER USER;

Follow the step from (1) to (5) and knit 13 Rs of 1 x 1 rib.

#### 3. LEFT SHOULDER SEAMING

- (1) Pick up the left shoulder's sts (30) of BACK facing right side, onto the needles.
- (2) Put the left shoulder's sts (30) of FRONT facing purl side.  
Remove waste knitting.
- (3) Follow the same steps referring to RIGHT SHOULDER.

\* Do not forget to seam a neck band.

#### 4. SIDE SEAMING

Right side facing, pick up the loop between the first and the second st one by one. (See Fig. two by two can be done).

\* Never pull the yarn too tight.

#### 5. SEWING SLEEVES ON BODICE

- (1) Put sleeves and bodice inside out.
- (2) Shift the seaming of sleeve toward the front by 1 cm from side seaming of bodice, then pin up along the edges.
- (3) Sew sleeves onto the bodices with reverse stitching.

Apply a steam iron and fix the shaping.