

# **RIBBER**

**INSTRUCTION MANUAL**

**TOYOTA KR 460**



# CONTENTS

1. SETTING UP THE MACHINE . . . . .	1
2. GENERAL GUIDE TO TENSION DIAL AND YARN . . . . .	6
3. CASTING—ON . . . . .	7
4. FUNDAMENTAL RIB—KNITTING . . . . .	8
1 x 1 RIB . . . . .	8
SINGLE FISHERMAN'S RIB . . . . .	9
RIPPLING . . . . .	9
SKINNY RIB (TIGHTER) . . . . .	10
SKINNY RIB . . . . .	12
CLOSE RIB . . . . .	14
CIRCULAR KNITTING . . . . .	15
SWINGING RIB . . . . .	17
CABLE KNITTING . . . . .	18
TUCK PATTERN RIB . . . . .	19
5. PUNCH CARD RIB . . . . .	
HONEY COMB PATTERN . . . . .	20
PIN—TUCK KNITTING . . . . .	21
FAIR—ISLE DOUBLE KNIT . . . . .	22
6. INCREASING STITCHES . . . . .	24
DECREASING STITCHES . . . . .	25
7. USEFUL HINTS . . . . .	
CASTING—ON . . . . .	26
HOW TO USE DOUBLE—EYED TRANSFER TOOL . . . . .	27
HOW TO MAKE A KNOT . . . . .	28
BINDING OFF FOR THE RIB STITCHES . . . . .	28
8. PARTIAL KNITTING . . . . .	
1 x 1 RIB . . . . .	29
WHEN TUCK OR EMPTY BUTTONS ARE USED . . . . .	30
WHEN RACKING HANDLE IS USED . . . . .	31
9. HOW TO FIX THE MACHINE . . . . .	
CARRIAGE JAMMING . . . . .	32
REPLACING THE NEEDLE . . . . .	33
HOW TO USE MAIN KNITTER WITH SETTING RIBBER ON . . . . .	33
WHEN END STITCHES ARE NOT KNITTED . . . . .	34
HOW TO MOVE CARRIAGE WIHTOUT KNITTING . . . . .	34
HOW TO TAKE OFF THE KNITTED PIECE . . . . .	34
10. NAMES AND FUNCTION . . . . .	
RIB KNITTER . . . . .	35
RIB CARRIAGE . . . . .	35
RIB YARN FEEDER . . . . .	35
RIB YARN FEEDER BASE . . . . .	35
ACCESSORIES . . . . .	36

# 1. SETTING UP

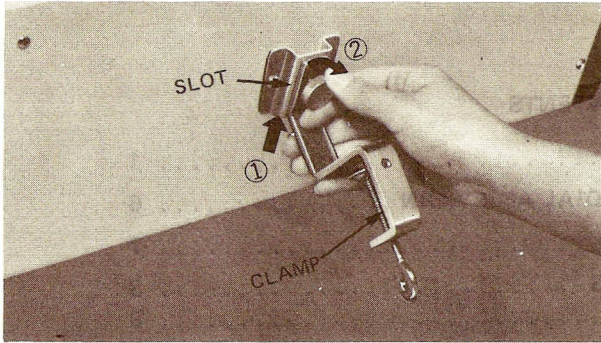

Screw the clamps to the bottom of main knitter.  
( ① ② )

\*Be sure the top of clamp and slot to be matched. The clamp and slot must be parallel.

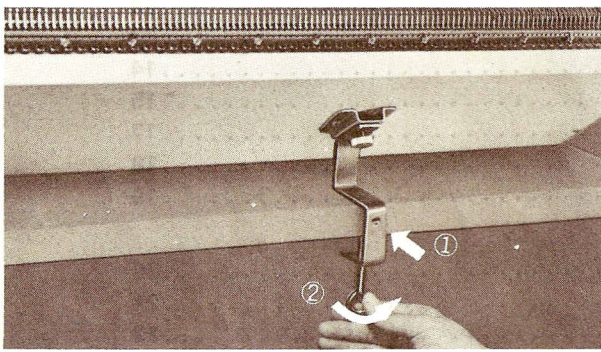

Attach main knitter onto table.  
( ① ② )

Be sure the clamp ① is closely fitted to the side of table without any gap.

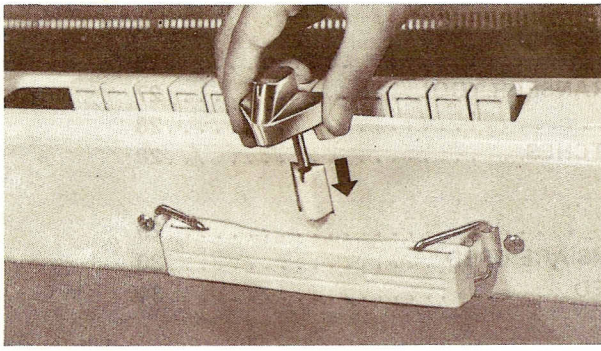

Set Upper Tension Rod Support at the back of main knitter.

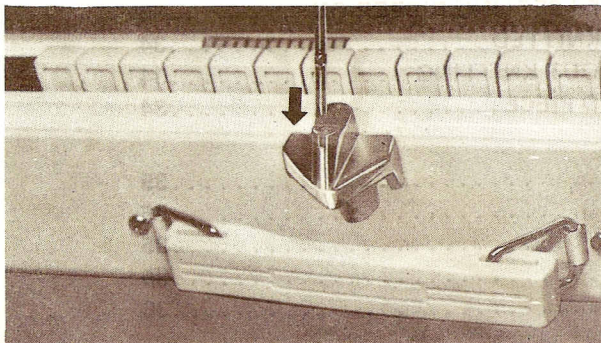

Insert Upper Tension Rod into the rod support with curved part downwards.

Loosen both Set Screws, and remove them.

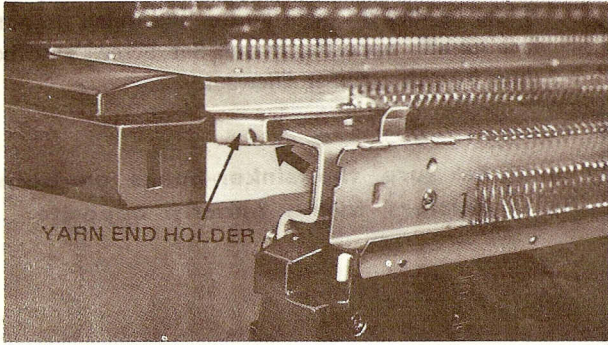

Install right Hanging Plate onto Yarn End Holder, then the left one next.

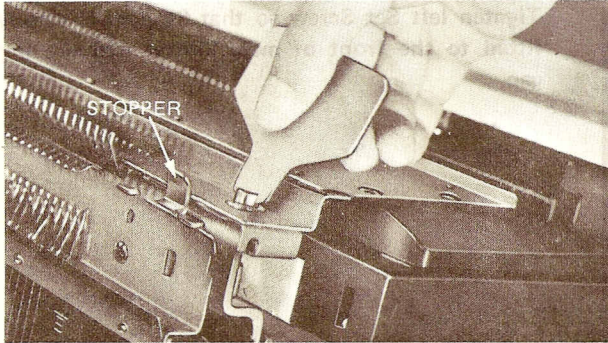

Tighten right Set Screw.

\* A slight gap between the Stopper and the front of the main knitter will cause improper gauge in knitting or dropping stitch.

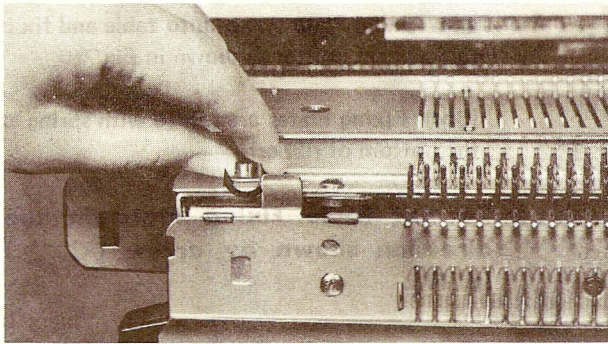

Fix left Hanging Plate in the same way as the right one.

Install left Set Screw leaving it loose temporarily for adjustment.

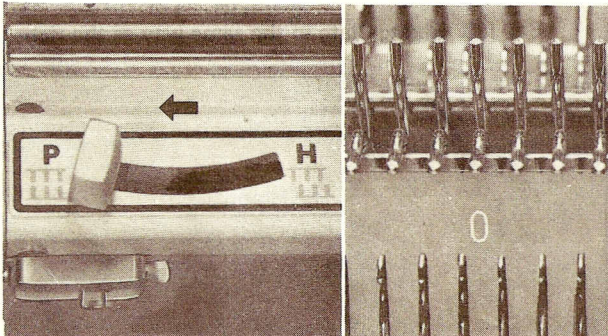

Set Half Pitch Lever to "P" position, and Racking Indicator at "5".

\*Be sure the center sinker-hooks of both knitter are parallel.

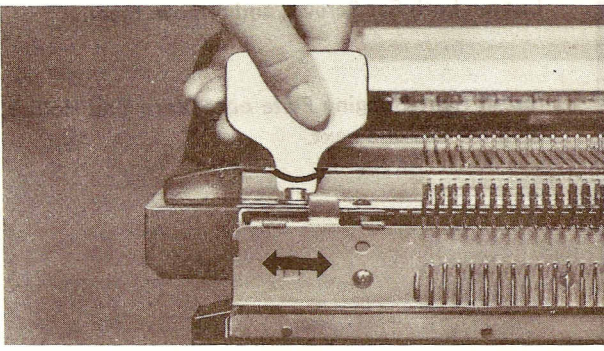

If the needles on main knitter and ribber do not face exactly opposite, loosen Set Screws and fix them by sliding ribber sideways.

**\* Be sure the sinker-hooks on both knitters facing exactly opposite.**

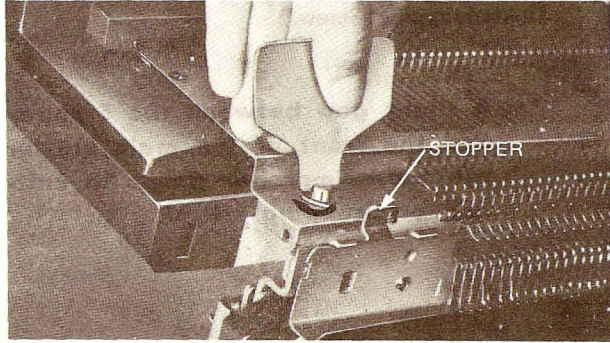

Tighten left Set Screw so that Stopper is closely fitted to the front of main knitter without any gap.

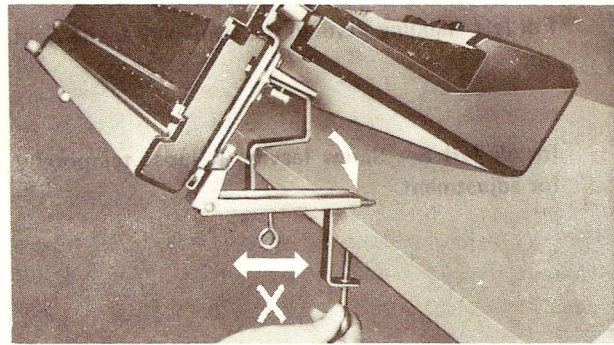

Pull right Fixing Plate down onto table and fix it by clamp of main knitter as shown in Fig.

(Both Fixing Plates are folded with spring at the bottom of ribber)

**\* Do not force Fixing Plate in the direction shown by arrow (↔) in Fig.**

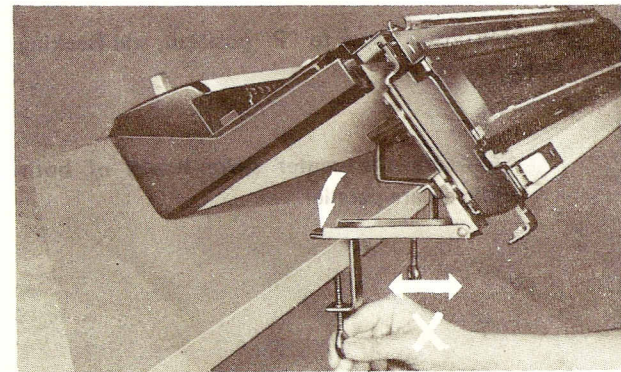

Set left Fixing Plate in the same way as the right.

## Attach Racking Handle.

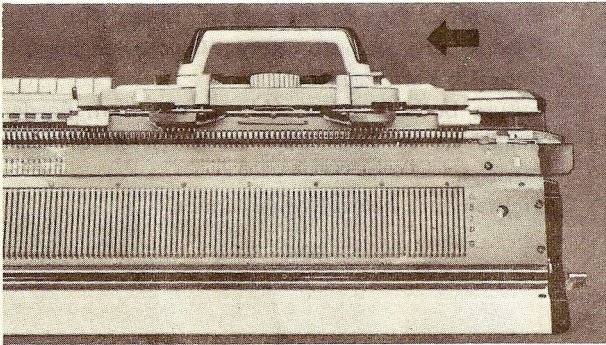
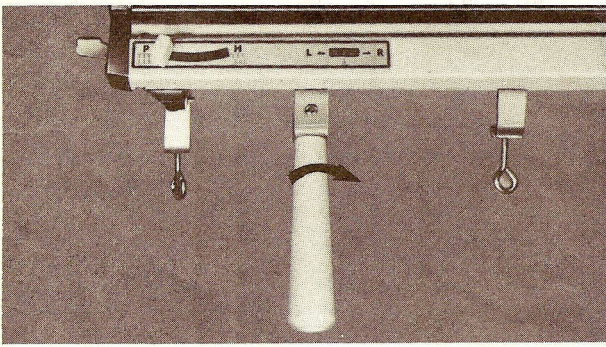

Fix the handle to main carriage, and place carriage correctly on the needle bed so that it slides smoothly.

\*Be sure Front Holder is correctly mounted onto the needle bed.

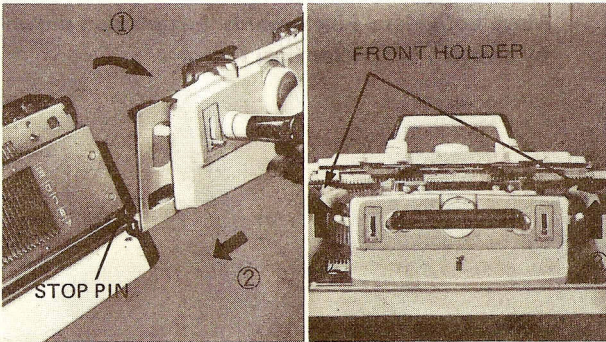

Fix the handle to ribber carriage, and set carriage in the following way.

1. Mount the bottom of ribber carriage onto the rail, leaning it towards you. ①
2. Slide carriage in side way, ensuring it won't hit Stop Pin. ②
3. Fix carriage by pushing up both Front Holders. ③

\* Do not force carriage against Stop Pin, which prevents carriage from dropping.

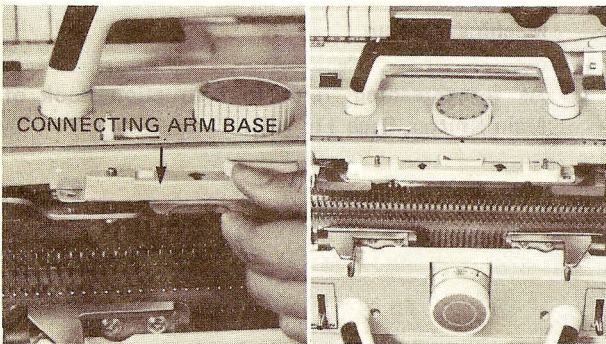

Remove both Fabric Presser Knobs of main carriage.

Set Rib Yarn Feeder Base so that the arrow marks face to main knitter.

\*Make sure both holes of Rib Yarn Feeder Base are correctly fitted to pins of main carriage.

Place ribber carriage just opposite main carriage.

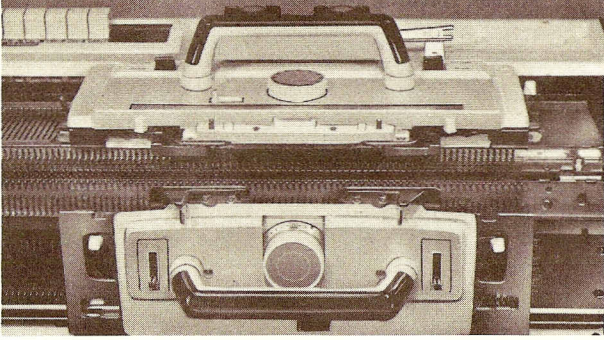

Slide Metal Pins to the center. Mount Rib Yarn Feeder between both Carriage Guides and place it onto Rib Yarn Feeder Base.

Ensure both cut-outs (A) of Rib Yarn Feeder snugly fit to small pegs on the front of main carriage.

Tighten both Fabric Presser Knobs.

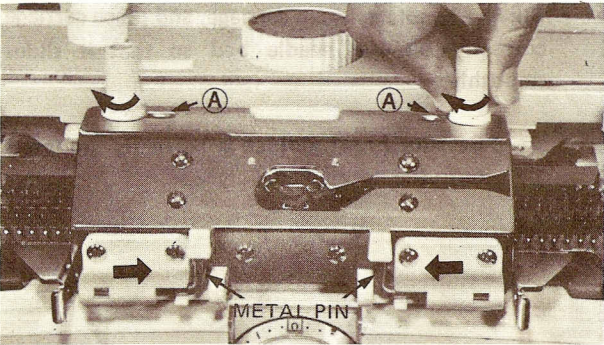

Move both Metal Pins towards the direction shown by arrows (1 2) for final fixing.

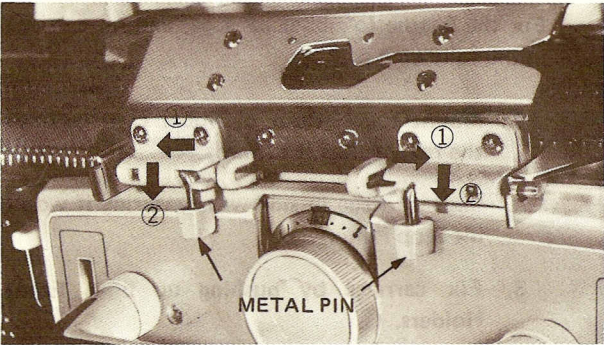

Machine is set up.

As for threading, refer to Instruction Book of Main Knitter, Page 11.

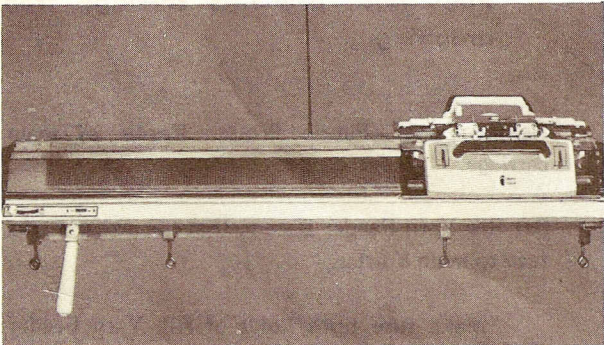

## 2. GUIDE TO TENSION DIAL AND YARN

- \* Set Upper Tension Dial between "40" and "—" .
- \* For smooth knitting, use paraffin wax.
- \* It is recommended to hang small weights at both sides to prevent the end stitches from coming up (See page 34).

ex.  $\frac{1}{0} \dots \frac{\text{Main Tension Dial}}{\text{Rib Tension Dial}}$

(Names of the kinds of yarn will vary in each country.)

Kinds of Yarns (In live size)												
Names		Fine medium 3ply	Medium 4ply	Thick 2ply	Thick 3ply	Crepe 5(4)ply	6ply	Crepe 8ply	Boucle	Mohair	Tweed	
1x1 Rib	Casting-on (1st threading)	$\frac{0}{0}$	$\frac{0}{0}$	$\frac{0}{0}$	$\frac{0}{0}$	$\frac{0}{0}$	$\frac{1}{1}$	$\frac{3}{3}$	$\frac{0}{0}$	$\frac{0}{0}$	$\frac{0}{0}$	
	Casting -on (3rows of knitting)	2nd row	$\frac{1}{0}$	$\frac{2}{0}$	$\frac{2}{0}$	$\frac{2}{0}$	$\frac{3}{0}$	$\frac{6}{1}$	$\frac{8}{3}$	$\frac{3}{0}$	$\frac{2}{0}$	$\frac{3}{0}$
		3rd and 4th rows	$\frac{1}{1}$	$\frac{2}{2}$	$\frac{2}{2}$	$\frac{2}{2}$	$\frac{3}{3}$	$\frac{6}{6}$	$\frac{8}{8}$	$\frac{3}{3}$	$\frac{2}{2}$	$\frac{3}{3}$
	Ribbing	$\frac{1}{1}$	$\frac{2}{2}$	$\frac{2}{2}$	$\frac{2}{2}$	$\frac{3}{3}$	$\frac{6}{6}$	$\frac{8}{8}$	$\frac{3}{3}$	$\frac{2}{2}$	$\frac{3}{3}$	
Skinny Rib (2x2 Rib) (Tighter Rib)	Casting-on (1st threading)	$\frac{0}{0}$	$\frac{2}{2}$	$\frac{1}{1}$	$\frac{1}{1}$	$\frac{2}{2}$	$\frac{3}{3}$	$\frac{3}{3}$	$\frac{1}{1}$	$\frac{1}{1}$	$\frac{2}{2}$	
	Casting -on (3 rows of knitting)	2nd row	$\frac{2}{0}$	$\frac{4}{2}$	$\frac{4}{1}$	$\frac{4}{1}$	$\frac{5}{2}$	$\frac{7}{3}$	$\frac{8}{3}$	$\frac{5}{1}$	$\frac{4}{1}$	$\frac{5}{2}$
		3rd and 4th rows	$\frac{2}{2}$	$\frac{4}{4}$	$\frac{4}{4}$	$\frac{4}{4}$	$\frac{5}{5}$	$\frac{7}{7}$	$\frac{8}{8}$	$\frac{5}{5}$	$\frac{4}{4}$	$\frac{5}{5}$
	Ribbing	$\frac{2}{2}$	$\frac{4}{4}$	$\frac{4}{4}$	$\frac{4}{4}$	$\frac{5}{5}$	$\frac{7}{7}$	$\frac{8}{8}$	$\frac{5}{5}$	$\frac{4}{4}$	$\frac{5}{5}$	
Close Rib	Casting-on (1st threading)	$\frac{0}{0}$	$\frac{1}{1}$	$\frac{1}{1}$	$\frac{1}{1}$	$\frac{1}{1}$	—	—	—	$\frac{1}{1}$	—	
	Casting -on	2nd row	$\frac{2}{0}$	$\frac{4}{1}$	$\frac{4}{1}$	$\frac{4}{1}$	$\frac{5}{1}$	—	—	—	$\frac{5}{1}$	—
		3rd and 4th rows	$\frac{2}{2}$	$\frac{4}{4}$	$\frac{4}{4}$	$\frac{4}{4}$	$\frac{5}{5}$	—	—	—	$\frac{5}{5}$	—
	Ribbing	$\frac{2}{2}$	$\frac{4}{4}$	$\frac{4}{4}$	$\frac{4}{4}$	$\frac{5}{5}$	—	—	—	$\frac{5}{5}$	—	
Circular Knitting		$\frac{4}{4.2}$	$\frac{5}{5.2}$	$\frac{5}{5.2}$	$\frac{5}{5.2}$	$\frac{6}{6.2}$	$\frac{7}{7.2}$	$\frac{8}{8.2}$	$\frac{6}{6.2}$	$\frac{5}{5.2}$	$\frac{6}{6.2}$	



### 3. CASTING - ON

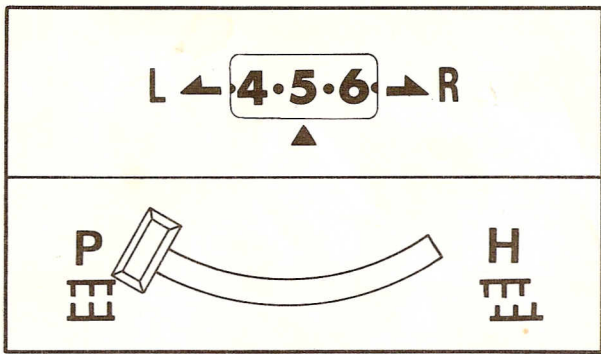

1. Set Racking Indicator at "5" and Half Pitch Lever at "P".

\* To prevent the needles from being damaged, be sure not to operate Racking Handle with leaving the needles on both beds at selected position.

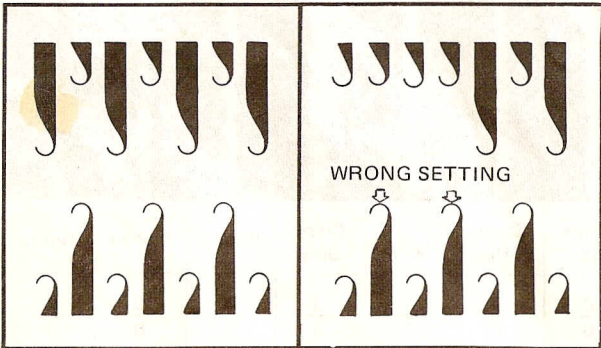

2. Set alternate needles on both beds with end needles on main bed.

\* When more than 180 needles are used, set extension rails.

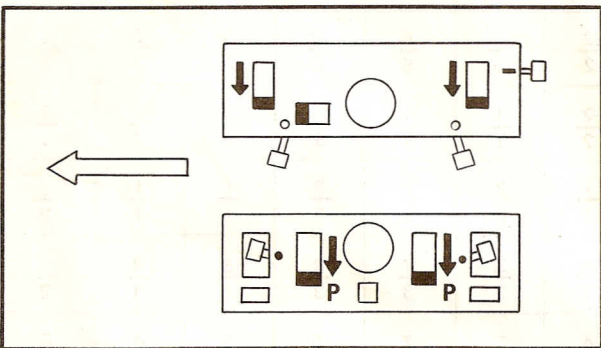

3. All buttons and levers are in neutral. (Set tension dials at "0" for 4ply in use, see page 6.)

4. Threading.  
Hold the end of yarn by hand.

5. Move carriages to the left.

\* Move carriages slowly, pushing them down.

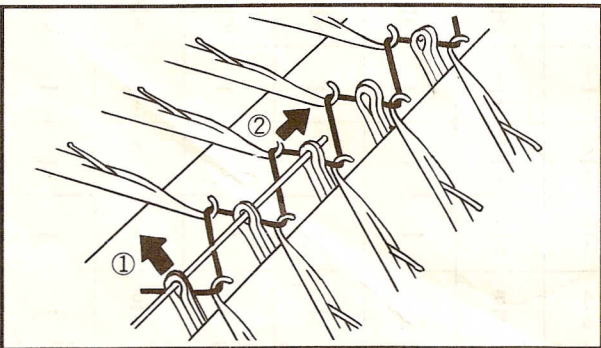

6. Hang cast-on comb. Pull out the cast-on comb wire. Push teeth between the beds, through the stitches done at the very beginning ①, place wire through teeth ②, allow the comb to drop and hang on weights. Fasten yarn end to Knitting Weight.

\* Hang weights on comb so as to be balanced.

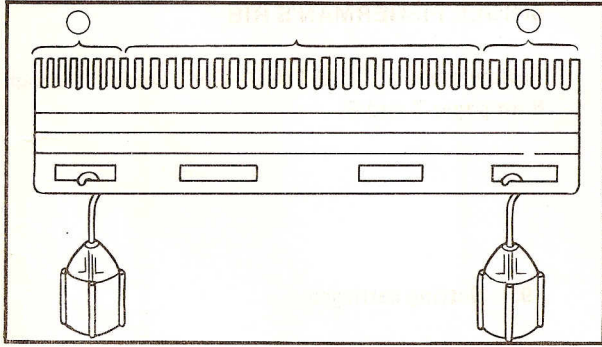

## GUIDE TO WIDTH OF KNITTING AND THE WEIGHT

(In close rib in medium yarn)

TOTAL NO. OF WORKING NEEDLES	NO. OF REQUIRED WEIGHTS
UP TO 30sts	1
30sts ~ 60sts	2
60 ~ 90	3
90 ~ 120	4
120 ~ 150	5
150 ~ 200	6

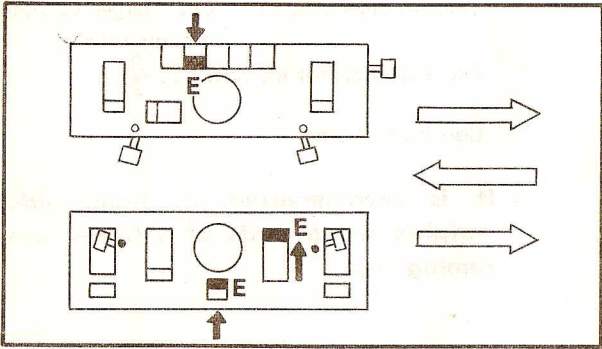

\* Number of required weights will be different according to yarn and stitch patterns.

### 7. Setting carriages

Main carriage . . . . .left "Empty"

Rib carriage . . . . .right "Empty"  
center "Empty"

### 8. Carriage is on the left.

Knit 3 rows changing both tension dials (refer to page 6).

Casting-on is completed.

(Make sure to start casting-on of the stitches on main knitter first.)

## 4. FUNDAMENTAL RIB KNITTING 1 x 1 RIB

Follow steps of "CASTING ON", from 1 through 8 on pages 7 and 8.

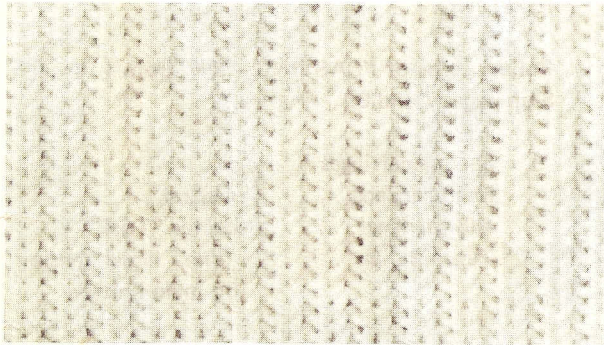

### 9. Release "Empty" buttons on both carriages to make them in neutral (see Fig).

### 10. Set tension dials for "1 x 1 rib."

ex. Dials are at "2" for 1 x 1 rib in medium yarn (see page 6).

Continue ribbing.

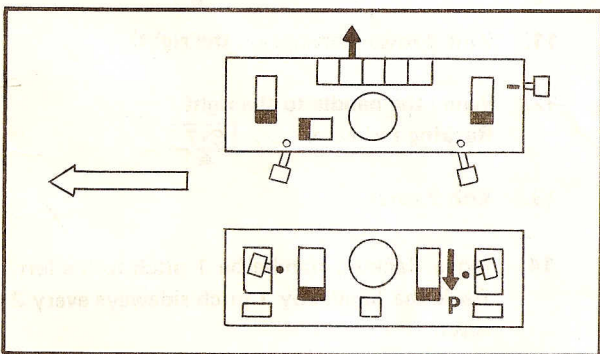

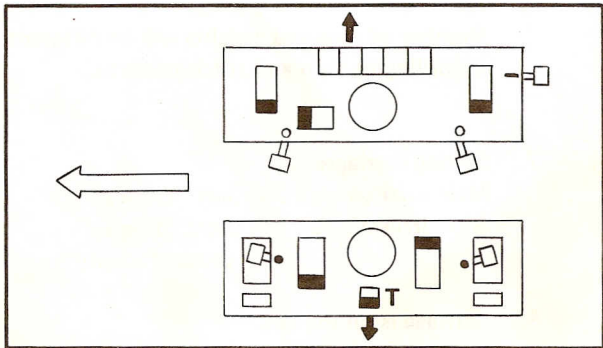

**SINGLE FISHERMAN'S RIB**

Follow steps of "CASTING-ON", from 1 through 8 on pages 7 and 8.

**9. Setting carriages**

Main carriage . . . . .neutral  
 Rib carriage . . . . .center "Tuck"  
 Tension dials . . . . ."one" larger tension  
 on main knitter.  
 (ex. Ten Dials for m. yarn. . . .  $\frac{3}{2}$  )

Continue ribbing.

\* It is recommended to hang side weights when ends of stitches are coming up.

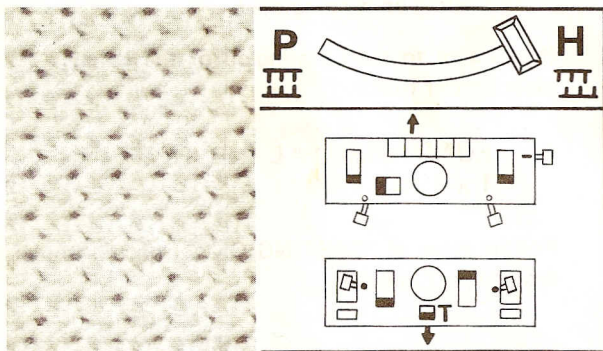

**RIPPLING**

Follow steps of "CASTING-ON" from 1 through 8 on pages 7 and 8.

**9. Setting carriages**

Main carriage . . . . .neutral  
 Rib carriage . . . . .center "Tuck"  
 Tension dials . . . . ."one" larger tension  
 on main knitter.

10. Half Pitch Lever . . . ."H"  
 Racking Indicator . . . .  $\boxed{5 \cdot 6}$

11. Knit 2 rows (carriage on the right).

12. Swing the handle to the right.  
 Racking Indicator . . . .  $\boxed{6 \cdot 7}$

13. Knit 2 rows.

14. Move Racking Handle be 1 pitch to the left.  
 Rack the handle by 1 pitch sideways every 2 rows.

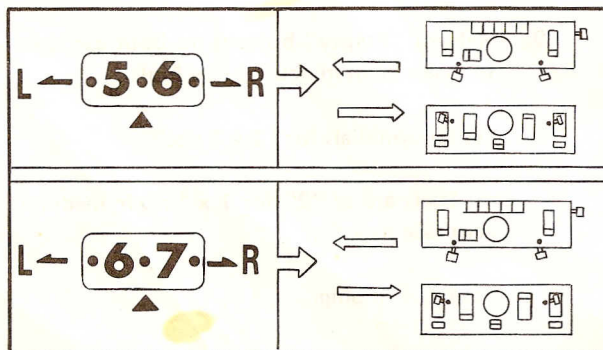

Continue ribbing.

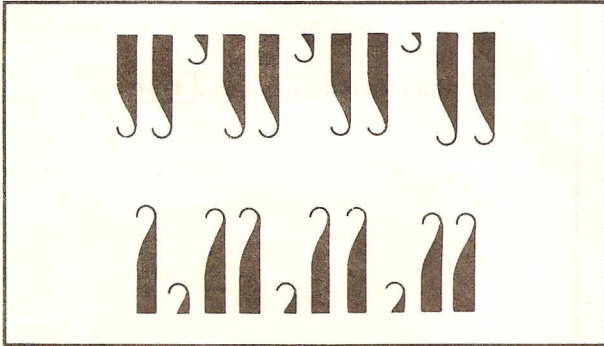
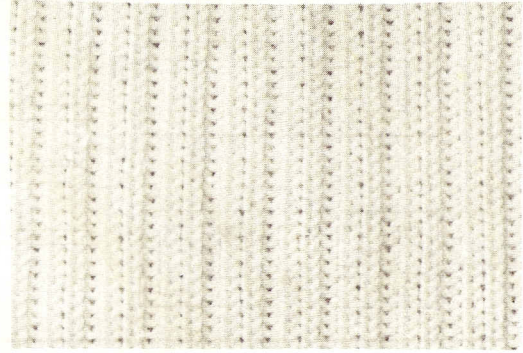
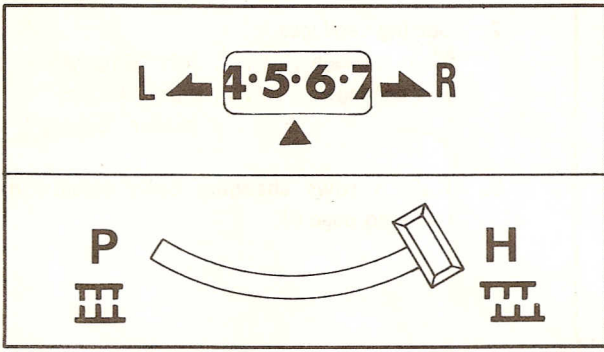

1. Half Pitch Lever . . . . . "H"  
Racking Indicator . . . . . 5·6  
▲
2. Setting needles (see Fig.)

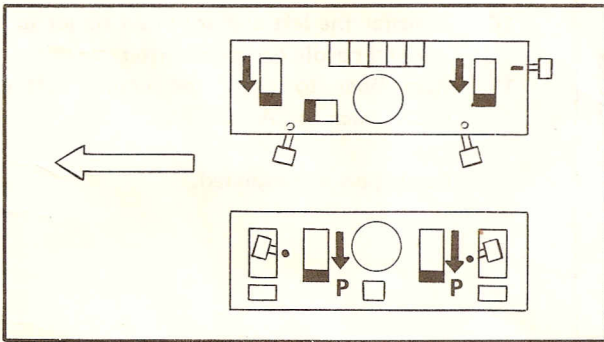

3. All buttons and levers are in the neutral positions. Set tension dials (see page 6).
4. Thread yarn.

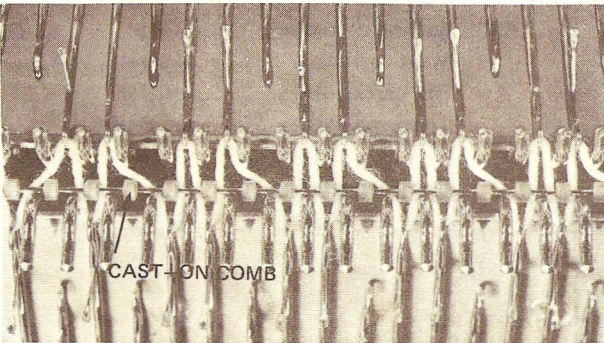

5. Knit the first row to the left (see how yarn is hooked).
6. Hang cast-on comb and balance weights.

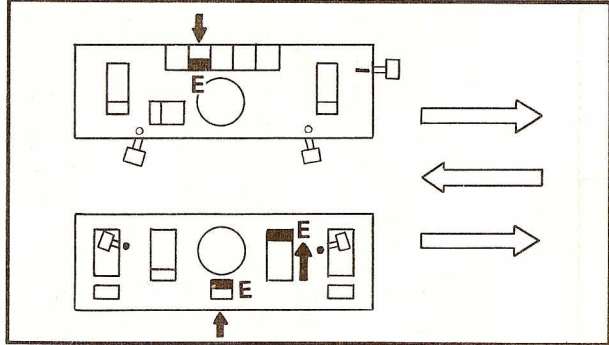

7. Setting carriages  
 Main carriage . . . . .left "Empty"  
 Rib carriage . . . . .right "Empty"  
 center "Empty"

8. Knit 3 rows changing both tension dials  
 (refer to page 6).

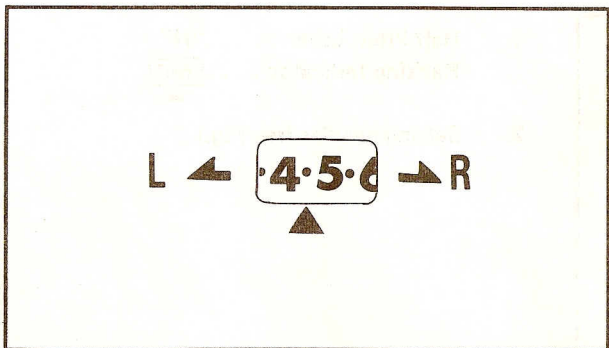

9. Move Racking Handle by one click to the left.  
 Racking Indicator . . . 4.5  
 ▲

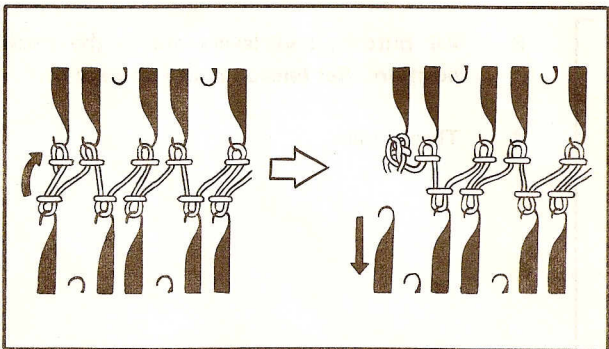

10. Transfer the left end stitch on ribber to the left end needle on main knitter.  
 11. Remember to bring the empty left end needle back to "A" position.

Casting-on is completed.

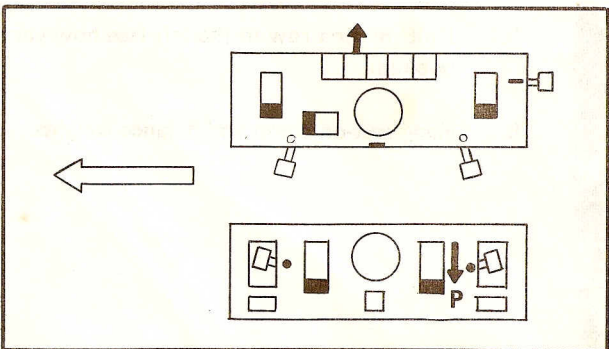

12. Setting carriages  
 Main carriage . . . . .neutral  
 Rib carriage . . . . .neutral  
 Tension Dials . . . . .see page 6

Continue ribbing.

## 2 X 2 RIB (SKINNY RIB)

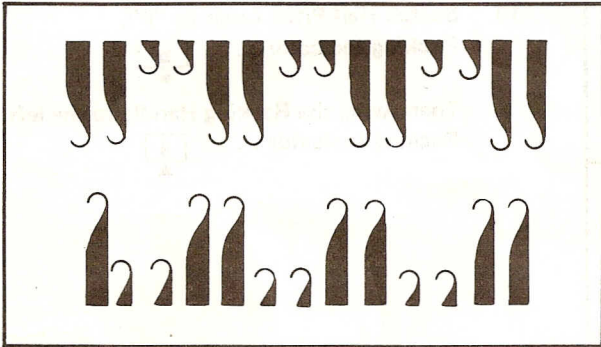
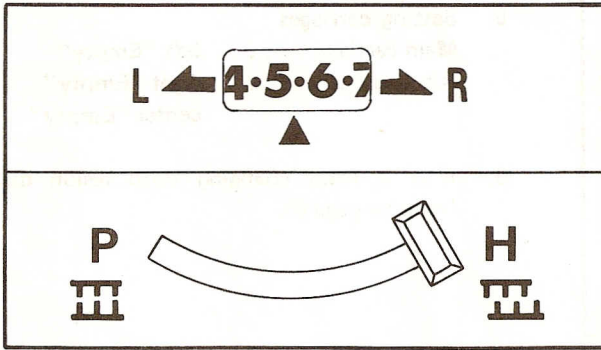

1. Half Pitch Lever . . . . . "H"  
Racking Indicator . . . 5·6  
▲
2. Setting needles (see Fig.)

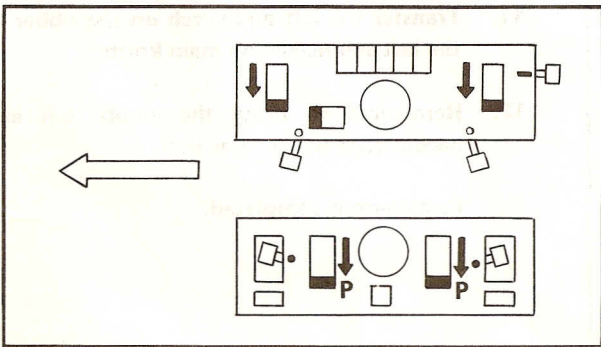

3. All buttons and levers in the neutral positions. Set both tensoin dials (see page 6).
4. Thread yarn.

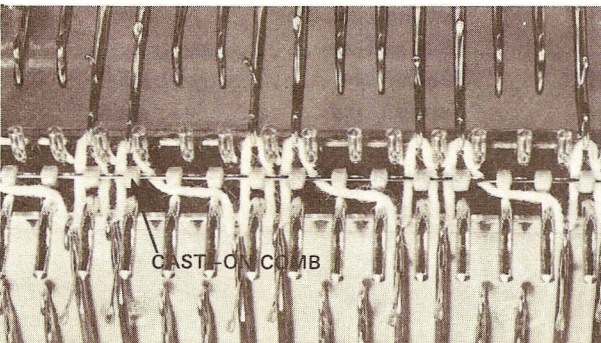

5. Knit the first row to the left (see how yarn is hooked).
6. Hang cast-on comb and balance weights.

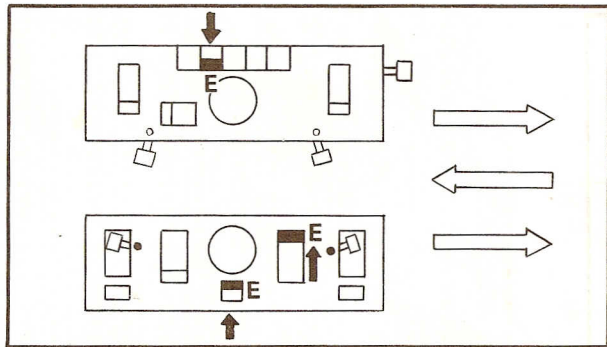

8. Setting carriages  
 Main carriage . . . . .left "Empty"  
 Rib carriage . . . . .right "Empty"  
 center "Empty"

9. Knit 3 rows changing both tension dials.  
 (refer to page 6).

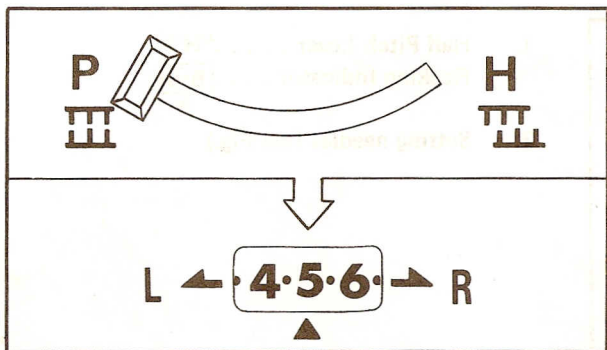

10. Switch Half Pitch Lever to "P".  
 Racking Indicator . . . .   
 ▲  
 Then swing the Racking Handle to the left.  
 Racking Indicator . . . .   
 ▲

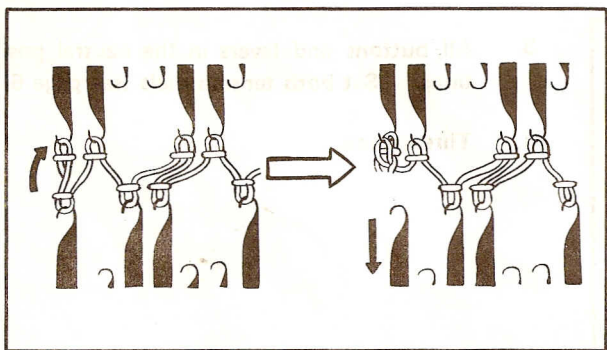

11. Transfer the left end stitch on the ribber to the left end needle on main knitter.  
 12. Remember to bring the empty left end needle back to "A" position.

Casting-on is completed.

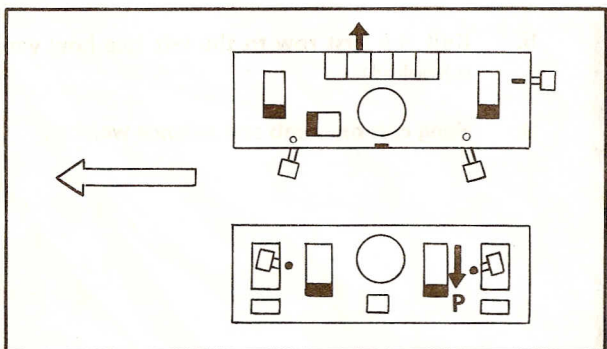

13. Setting carriages  
 Main carriage . . . . .neutral  
 Rib carriage . . . . .neutral  
 Tension Dials . . . . .See page 6

Continue ribbing.

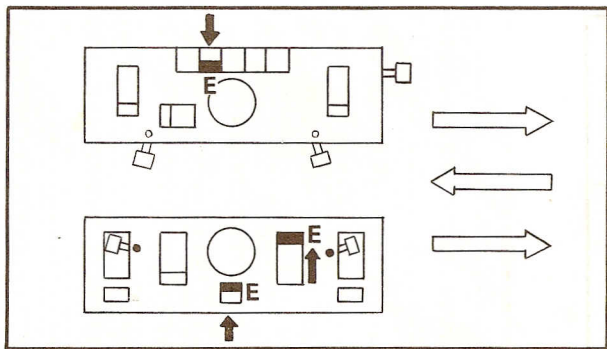

- 8. Setting carriages  
Main carriage . . . . .left "Empty"  
Rib carriage . . . . .right "Empty"  
center "Empty"

- 9. Knit 3 rows changing both tension dials.  
(refer to page 6).

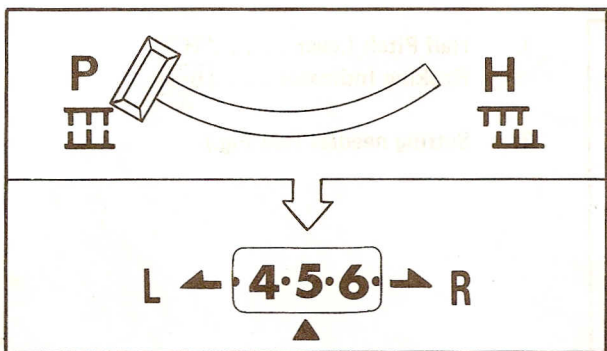

- 10. Switch Half Pitch Lever to "P".  
Racking Indicator . . . . 5  
▲  
Then swing the Racking Handle to the left.  
Racking Indicator . . . . 4  
▲

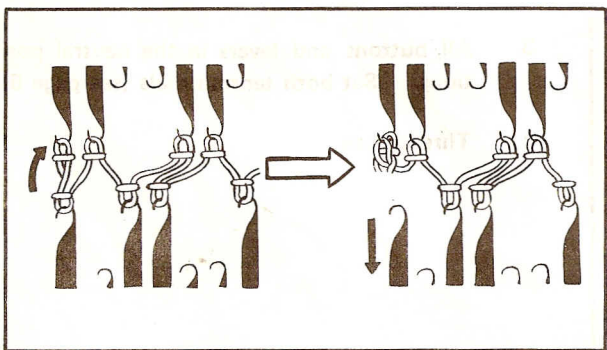

- 11. Transfer the left end stitch on the ribber to the left end needle on main knitter.
- 12. Remember to bring the empty left end needle back to "A" position.

Casting-on is completed.

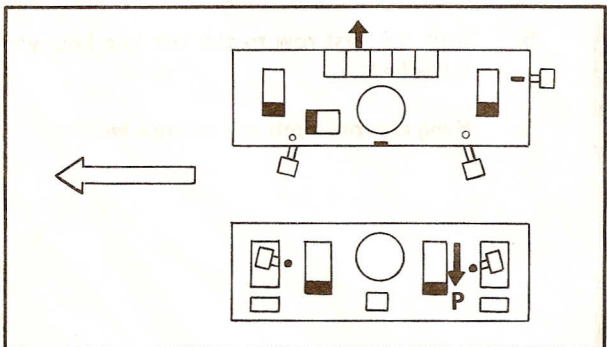

- 13. Setting carriages  
Main carriage . . . . .neutral  
Rib carriage . . . . .neutral  
Tension Dials . . . . .See page 6

Continue ribbing.



FULL  
CLOSE RIB

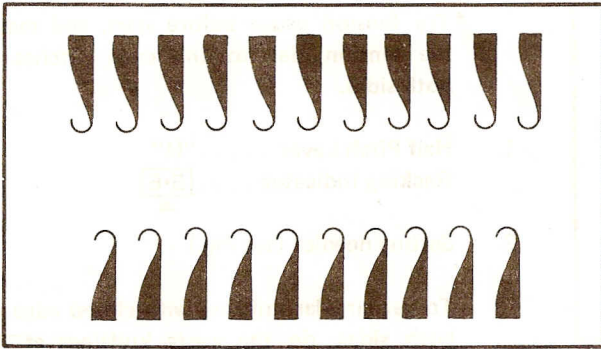
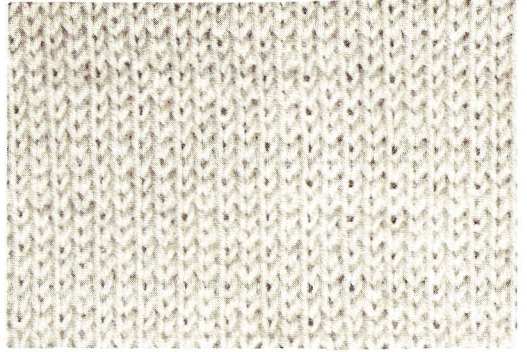
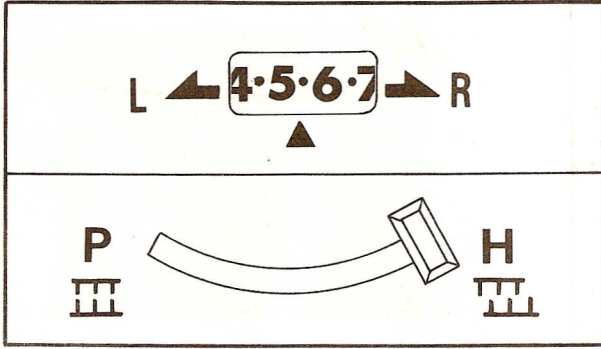

1. Half Pitch Lever . . . . "H"  
Racking Indicator . . . . 5·6
2. Setting needles (see Fig.)

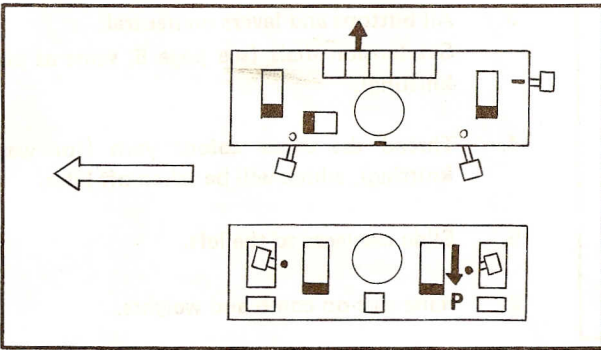

3. Set all buttons and levers in neutral position.  
Set tension dials (see page 6).

Follow steps 4 through 8 on pages 7 and 8.

Casting-on is completed.  
(carriage is on the right side.)

9. Release "Empty" buttons on both carriages to neutral.
10. Set tension dials to "Close rib".  
(Tension Dials. . . . .see page 6.)

Continue ribbing.

# CIRCULAR KNITTING

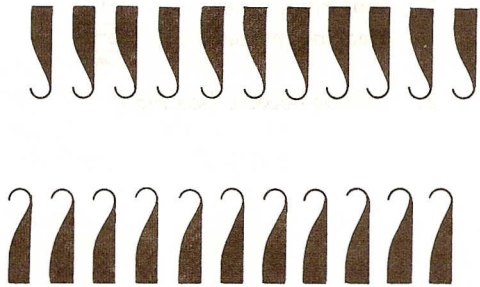
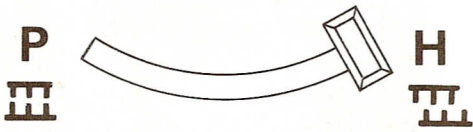
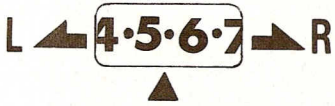

\*Try tension gauge before start, and match the tension dials to knit even stitches on both sides.

1. Half Pitch Lever . . . . . "H"  
Racking Indicator . . . . . 5·6

2. Setting needles. (see Fig.)

\* To get circular knitting with closed edge on both sides, do the waste knittings at the beginning and the last.

3. All buttons and levers on neutral.  
Set tension dials (see page 6, same as plain knitting).
4. Thread the other colour yarn (for waste knitting), which will be taken off later.
5. Slide carriages to the left.
6. Hang cast-on comb and weights.

7. Setting carriages  
Main carriage . . . . . left "Empty"  
Rib carriage . . . . . right "Empty"  
center "Empty"

8. Knit a few rows of waste knitting.

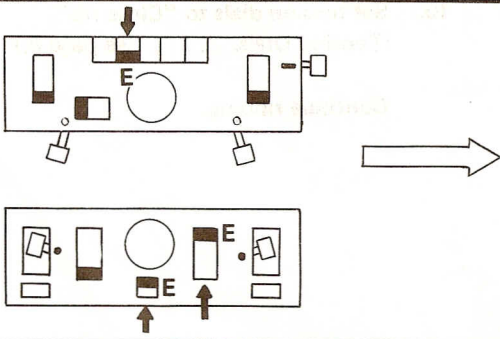
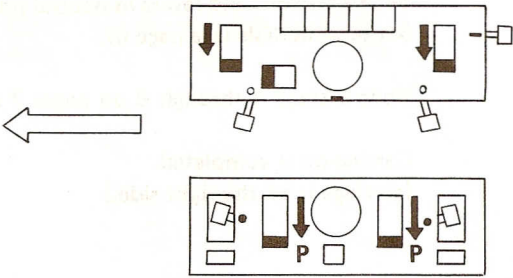

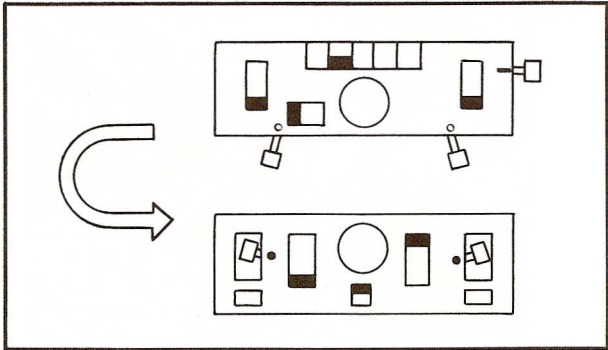

9. Carriage is on the right.  
Thread nylon cord.  
Knit two rows to make one row of circular knitting.

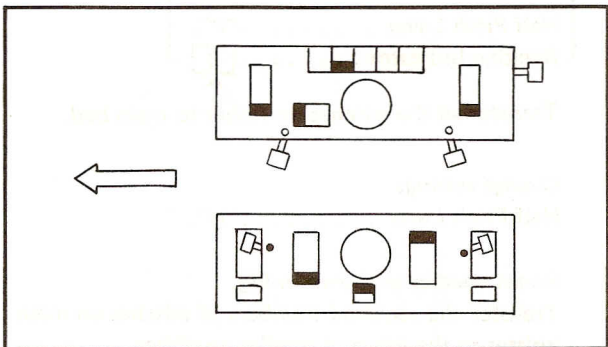

10. Unthread nylon cord.
11. Leave the yarn-end piece about three times as long as the width of the knitting section. It can be used to crochet edge.  
Thread main yarn into yarn feeder.

Continue circular knitting as much as required.

\* Again leave the piece of yarn in the same length for closing another edge.

\* To take it off:  
Knit two rows with nylon cord.  
Do another few rows of the waste knitting on top.

12. Unthread yarn then take off the knitted fabric.
13. Crochet both edges, holding the fabric inside out. Pull out the nylon cord so that the waste knitting piece will drop off.

\* When the ends of stitches come up while knitting, hang small weights.

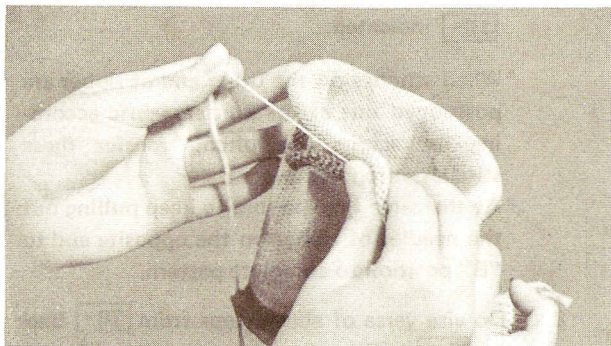
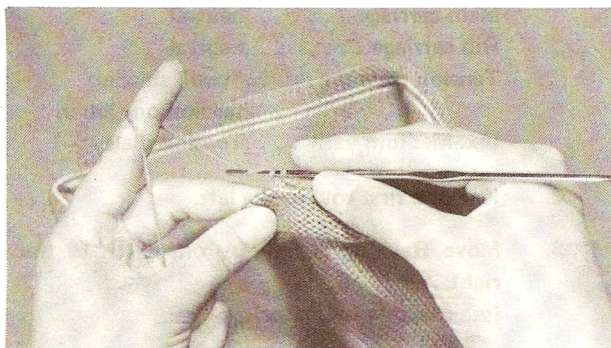



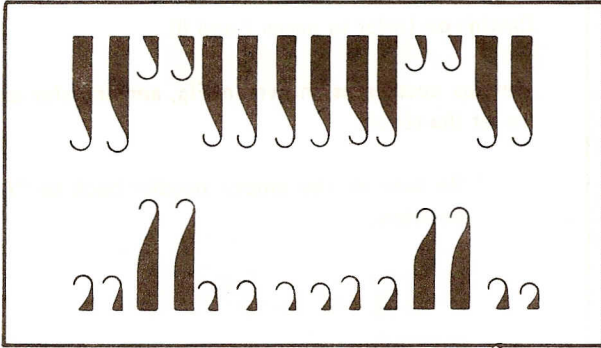
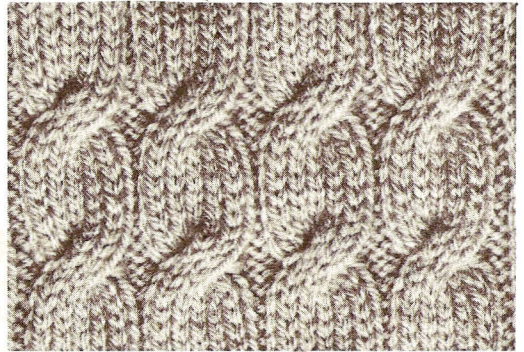
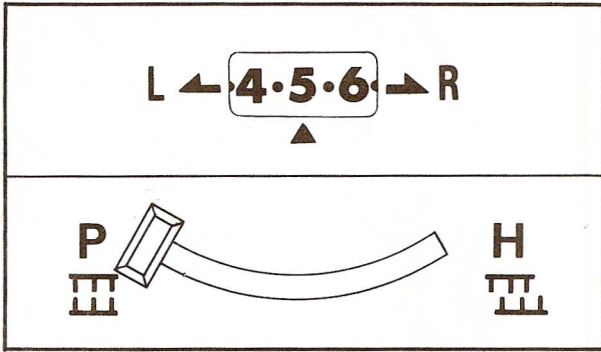

Casting-on (refer to pages 7 and 8).

Set up needles as shown in Fig, and transfer and re-set the stitch.

\* Be sure all the empty needles back to "A" position.

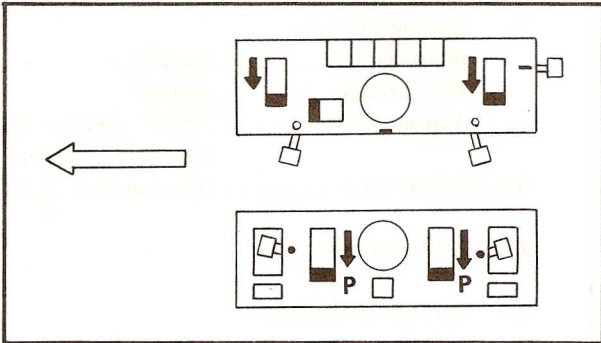

1. **Setting carriages**  
Main carriage . . . . .neutral.  
Rib carriage . . . . .neutral  
(ex.8 ply . . . . .Tension dials  $\frac{9}{9}$ )

2. **Knit required number of rows.**  
(ex, 10 rows)

3. **Transfer three stitches each other.**  
(refer to the Instruction Book of main knitter on page 36).

4. **Remember to pull out these six needles to "E" position.**

Repeat above steps 2 through 4.

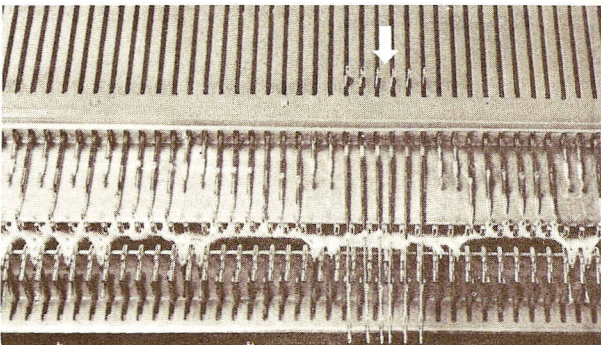

# TUCK PATTERN RIB

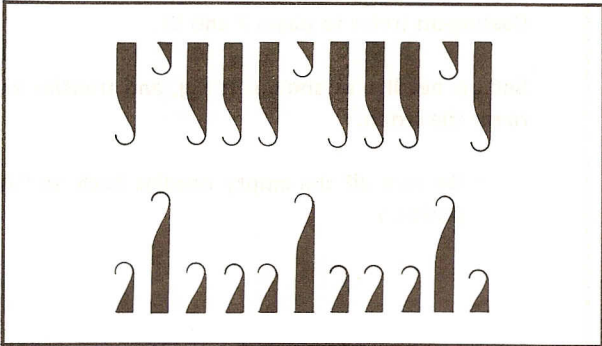
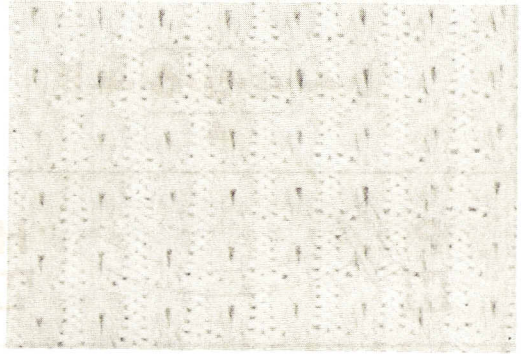
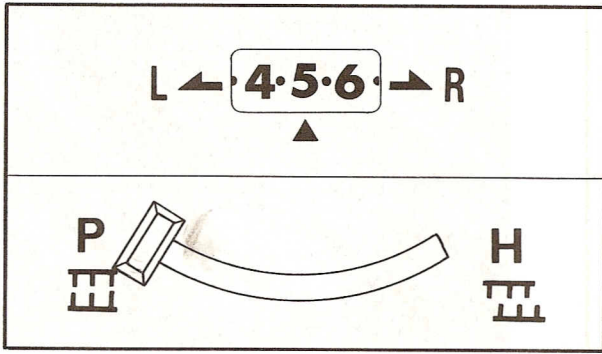

Casting-on (refer to pages 7 and 8).

Set up needles as shown in Fig, and transfer and re-set the stitch.

\* Be sure all the empty needles back to "A" position.

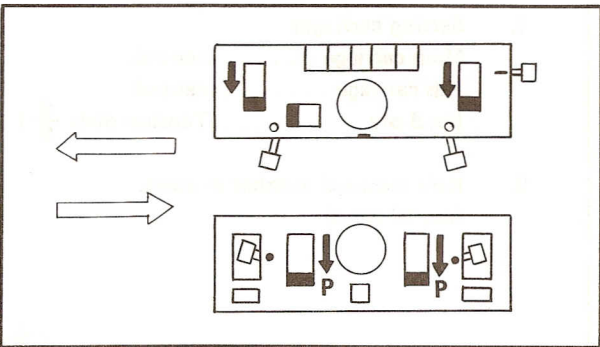

## 1. Setting carriages

Main carriage . . . . .neutral

Rib carriage . . . . .neutral

Tension dials . . . . ."two" smaller tension on the ribber.

(ex. Medium yarn . . . . .Tension dials  $\frac{5}{3}$ )

## 2. Knit two rows.

## 3. Setting rib carriage:

Knitting Levers . . . . ."Tuck" (up)

Tuck Lever. . . . . "Tuck" (down)

## 4. Knit 4 rows.

Repeat above steps from 1 through 4.

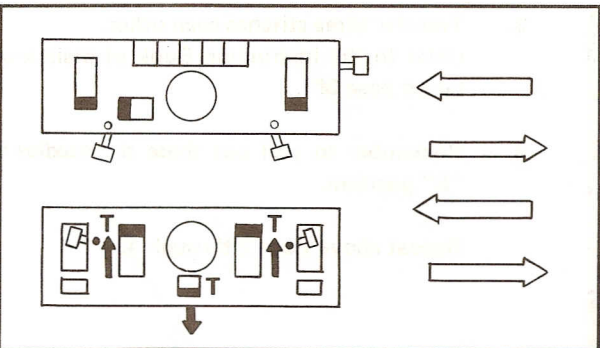

## 5. PUNCH CARD RIB

## HONEY COMB PATTERN

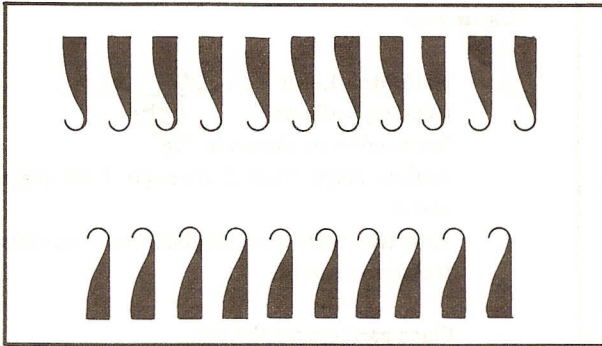
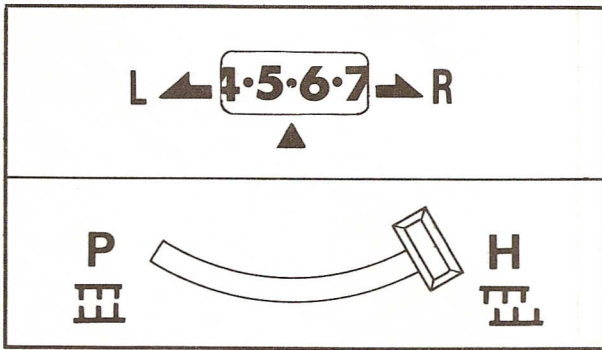

### Casting-on

Half Pitch Lever . . . . . "H"

Racking Indicator . . . . . 5 6

Set needles as shown in Fig. 1.

Follow steps from 3 through 7 on pages 7 and 8.

Knit two rows changing both tension dials (refer to page 6).

Place carriage on the left.

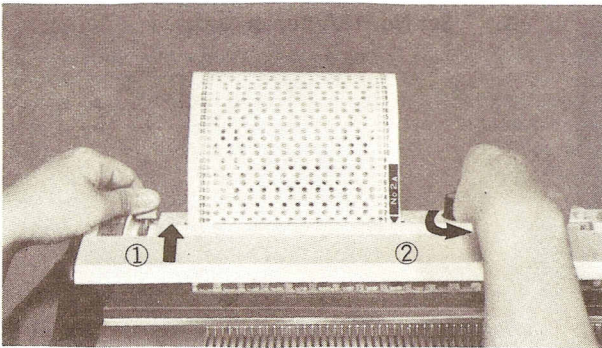

1. Set No. 2A punch card.

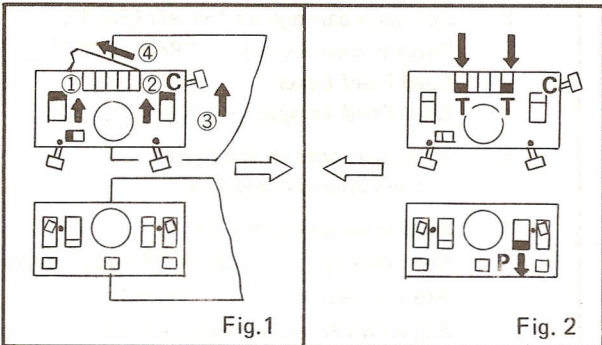

2. Set main carriage on the left (Fig.1):  
 Pattern Knit Lever . . . . . "PATTERN", ①, ②.  
 Card Feed Lever . . . . . "C", ③.  
 Card Feed Tripper . . . . . , ④.

3. Move carriage to the right (selects alternate needle).

\* It will be easier to push carriages holding the handle with both hands.

4. Setting carriages (Fig.2):  
 Main carriage . . . . . Both "TUCK" buttons.

Rib carriage . . . . . neutral.

Adjust both tension dials to knit.

(ex. Medium yarn . . . . . tension dials  $\frac{5}{5}$ ).

Continue ribbing.

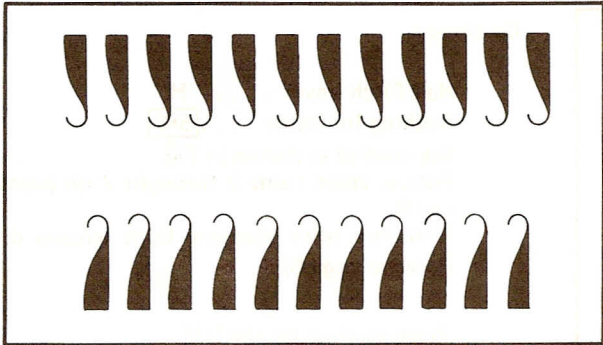
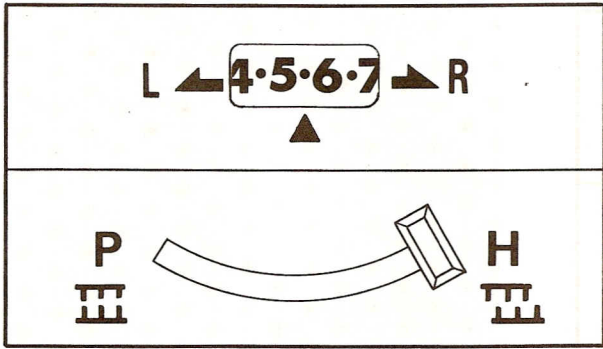

Casting-on

Half Pitch Lever . . . . . "H"

Racking Indicator . . . . . **5·6**

Set needles as shown in Fig. 

Follow steps from 3 through 7 on pages 7 and 8.

Knit two rows changing both tension dials (refer to page 6).

Place carriage on the left.

1. Set No. 18A punch card.

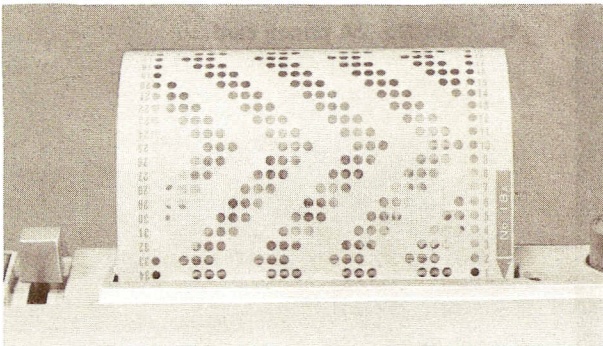

2. Set main carriage on the left (Fig.1):  
 Pattern Knit Levers . . . "PATTERN", ① ② .  
 Card Feed Lever . . . . . "C", ③ .  
 Card Feed Tripper . . . . . , ④

3. Move carriages to the right  
 -selects alternate needles.

4. Setting carriages (Fig 2):  
 Main carriage . . . . .Both "Empty" buttons.  
 Rib carriage . . . . . neutral  
 Adjust both tension dials to knit.  
 (ex. Medium yarn . . . tension dials  $\frac{5}{5}$  ).  
 Continue ribbing.

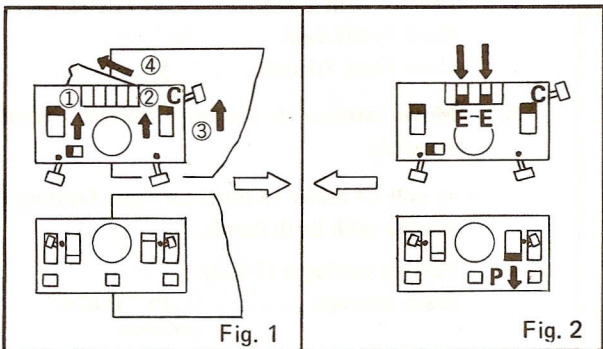



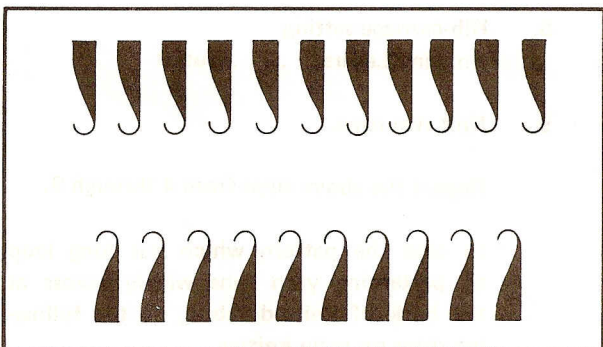
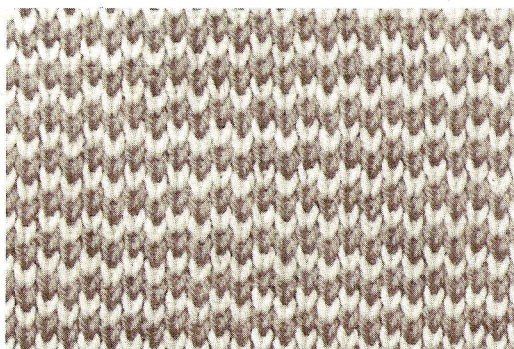
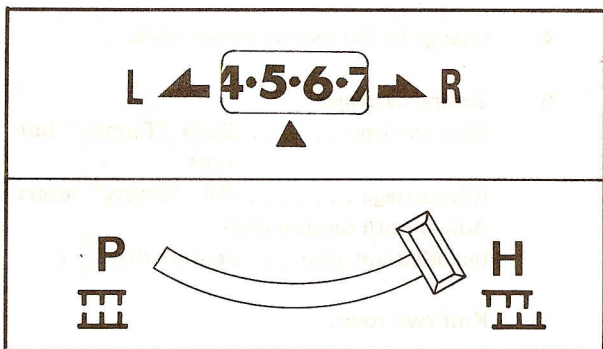

**Casting-on.**

Half Pitch Lever . . . . . "H"  
 Racking Indicator . . . . . [5·6]

Set needles as shown in Fig.  
 Follow steps from 3 through 7 on pages 7 and 8.  
 Knit two rows changing both tension dials (refer to page 6).  
 Place carriage on the left.

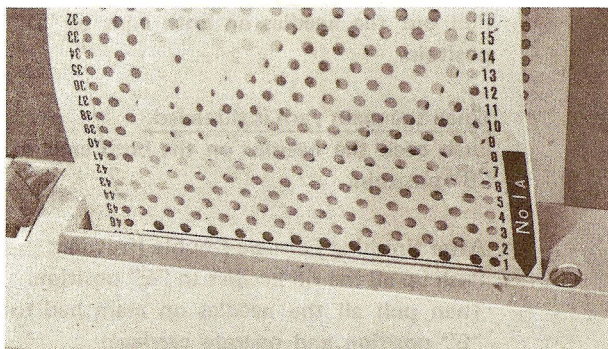

1. Set No. 1A punch card.

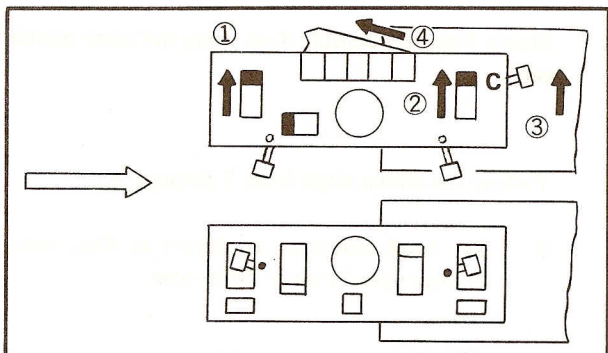

2. Set main carriage on the left

Pattern Knit Lever . . . . . "PATTERN" ①, ②.  
 Card Feed Lever . . . . . "C", ③.  
 Card Feed Tripper . . . . . "▲" ④.

3. Move carriage to the right. (selects alternate needles).

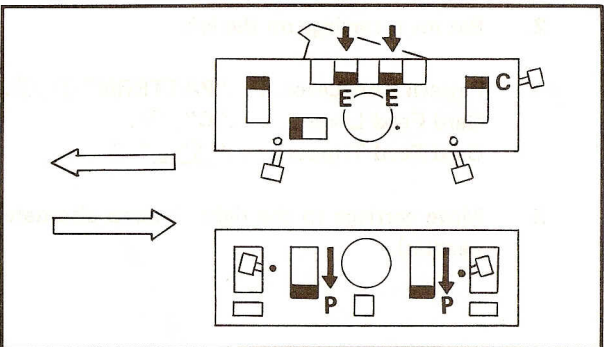
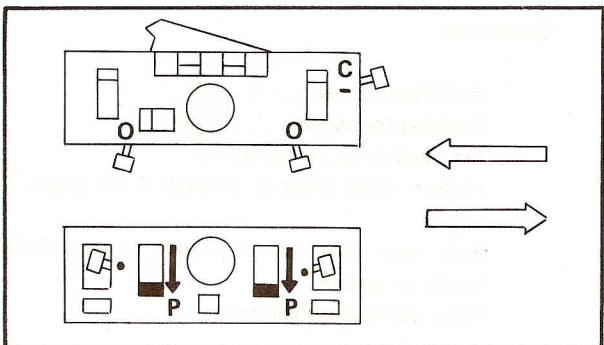
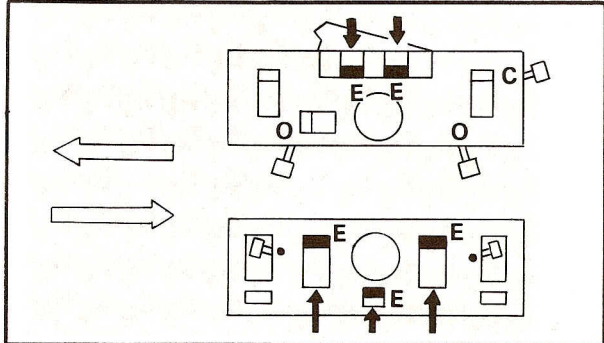

4. Change to the second colour yarn.
5. Setting carriages  
Main carriage . . . . .Both "Empty" buttons  
Rib carriage . . . . .All "Empty" levers.  
Adjust both tension dials.  
(ex. Medium yarn . . .tension dial  $\frac{4}{4}$  ).
6. Knit two rows.
7. Change to main colour yarn.
8. Rib-carriage setting  
Knitting Levers . . . . .neutral
9. Knit two rows.

Repeat the above steps from 4 through 9.

\* In case the pattern which has long loop of patterning yarn runs widely across at the back of knitted fabric, do the following stops on main knitter.

When the patterning yarn is threaded:

Pull out the needles on both ends to "D" positoin.

When the main yarn is threaded.

Push back the needles on the both ends to "B" positoin.

\* After finishing Fair-Isle Double Knitting:  
Push up all the rib needles to "E" position.  
Then pull all the needles on main bed to "E" position and operate carriage.

Elastic Fain Isle Double Knit using the same punch card.

Follow the above steps from 1 through 4.

5. Set both carriages as shown in Fig., then change yarn in every other row.

## 6. INCREASING STITCH (1 x 1 RIB)

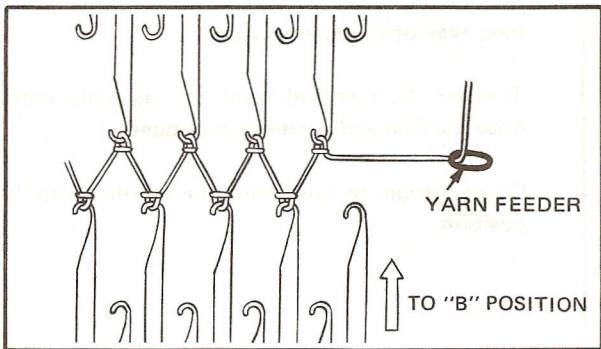

### Easy Way of Increasing Stitch

Pull out an empty needle next to the working needles on the carriage side to "B" position.

(When you knit the following row, the needle will catch yarn and a stitch will be formed.)

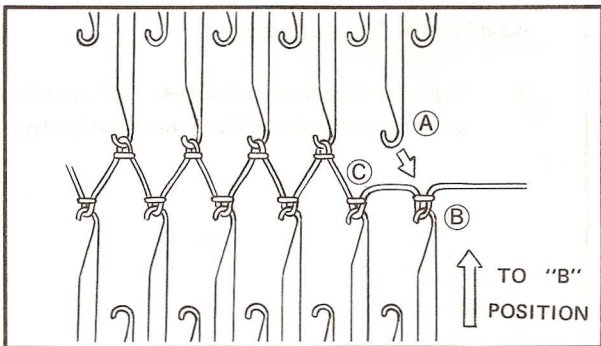

### Neat Way of Increasing Stitch

1. Transfer the first end stitch (A) on main knitter onto the empty needle (B) on ribber, using double-eyed transfer tool (refer to page 27).

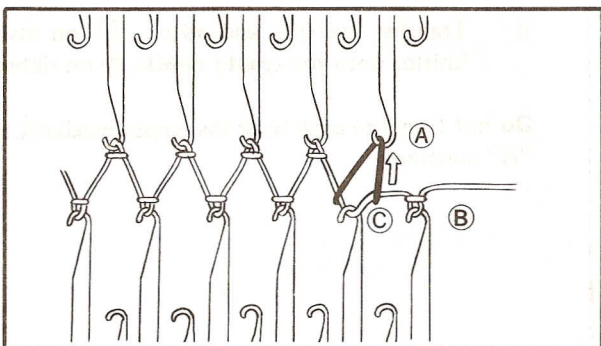

2. Pick up the loop under the stitch (C) on ribber, then hook it onto empty needle (A).

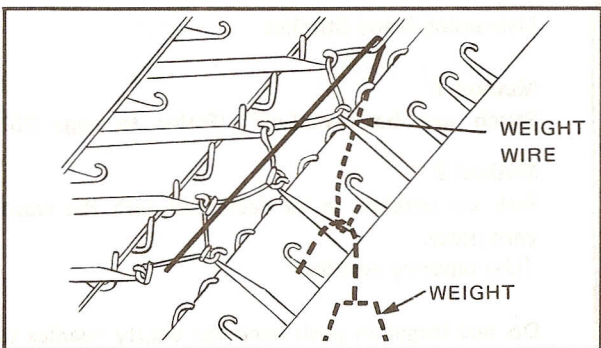

### Increasing Many Stitches

Pull required number of needles to be increased at both ends to "B" position.

(These needles must be on the opposite end to carriage.)

Knit one row, and yarn will be laid across over the needles pull out at the edge.

Hang the weight wire and small weight at the edge. (See Fig.)

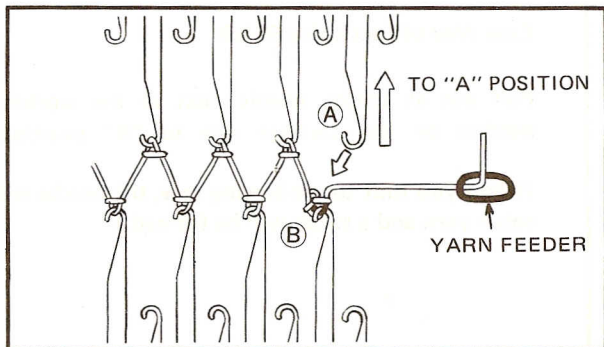

### Easy Way of Decreasing Stitch

Transfer the first end stitch (A) on main knitter onto the first end needle (B) on ribber.

Do not forget to push back the needle (A) to "A" position.

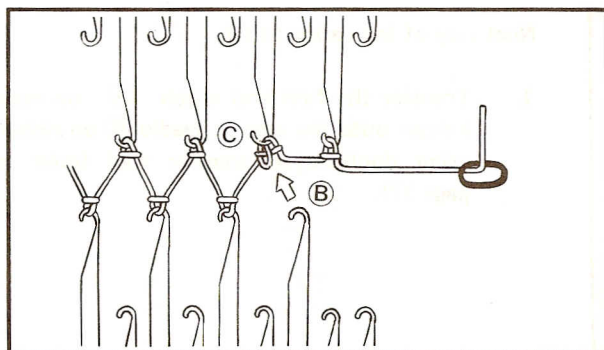

### Neat Way of Decreasing Stitch

1. Transfer the first end stitch (B) on ribber onto the second needle (C) on main knitter.

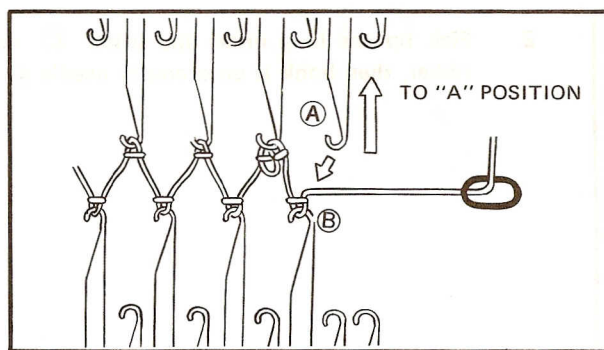

2. Transfer the first end stitch (A) on main knitter onto the empty needle (B) on ribber.

Do not forget to push back the empty needle (A) to "A" position.

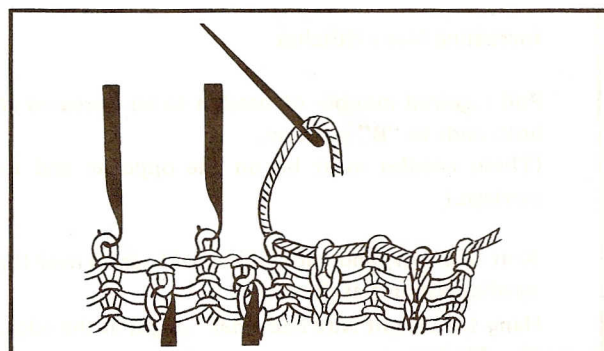

### Decreasing Many Stitches

#### Method 1

Stitch can be casted-off. (Refer to page 28).

#### Method 2

Pick up stitches to be decreased with the waste yarn piece.

(Use tapestry needle).

Do not forget to push back the empty needles to "A" position.

## 7. USEFUL HINTS

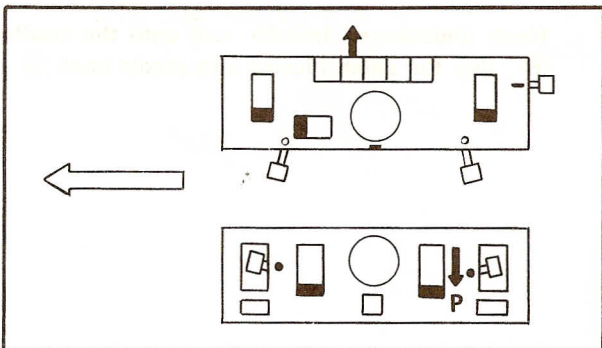
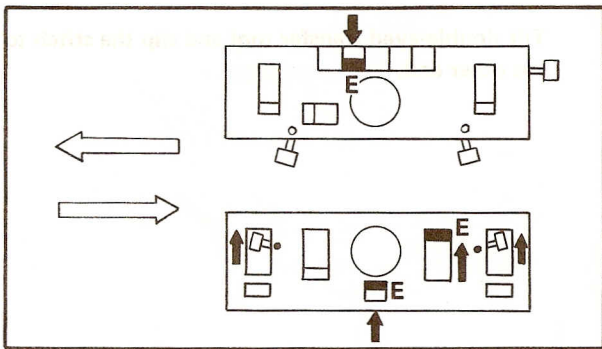
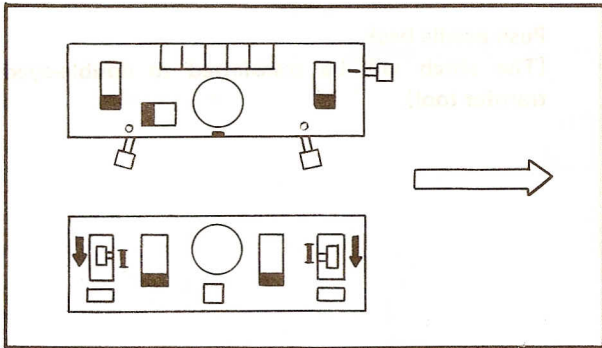
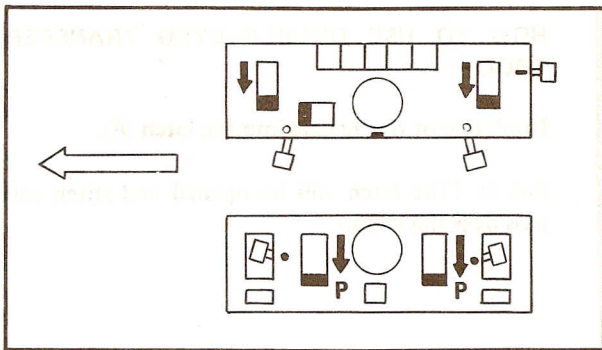

### CASTING-ON (FOR EDGE OF TIGHTER 1 X 1 RIB AND 2 X 2 RIB)

1. Half Pitch Lever . . . . . "P"  
Racking Indicator . . . . . 5
  2. Set required needles to "B" position.
  3. Place carriages on the right and set them in neutral.
  4. Set both Tension Dials. (Set them by one larger tension on both knitters than the tension numbers of the first row shown on page 6.)
  5. Knit the first row to the left using a nylon cord because it will be easier to pull it out later.
  6. Hang cast-on comb and balance weights.
  7. Pull out all needles on ribber to "E" position.
  8. Setting Rib carriage  
Partial Knitting Levers . . . . . "I"
  9. Knit the second row to the right.
  10. Setting carriages  
Main carriage . . . . . left "Empty" button  
Rib carriage . . . . . right and center  
"Empty" levers  
Both Partial Knitting  
Levers at " • "
  11. Knit two more rows.
  12. Set both carriages in neutral.
  13. Set Tension Dials (see page 6).  
Continue ribbing.
- \* After completed ribbing, remove cast-on comb and weights.
- \* Pull out yarn of the first row (nylon cord).

## HOW TO MAKE A KNOT

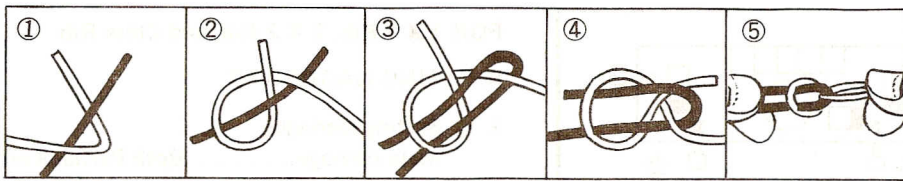

In order to make a small knot, the way as shown above is quite advisable.

\* It is recommendable not to knit in with a knot when thick yarn is used.

## BINDING OFF THE RIB STITCHES

This is the way of binding rib stitches using the yarn end left at the edge of the knitting.

### 1 x 1 RIBBING

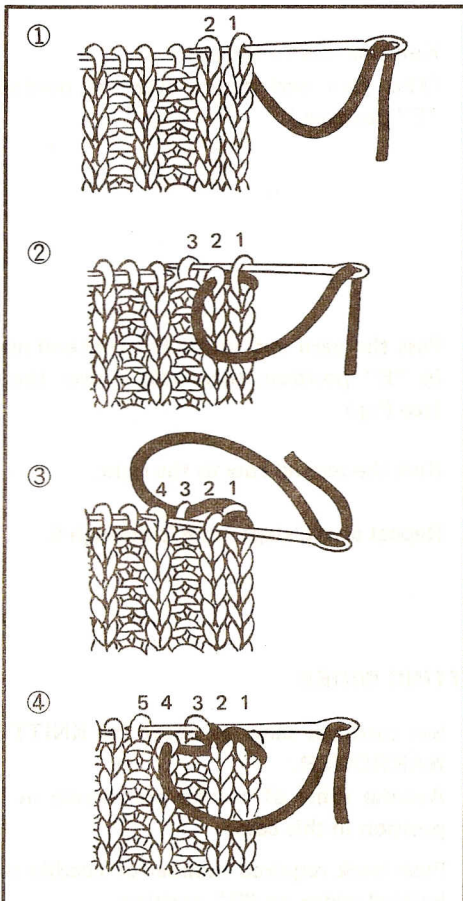

### 2 x 2 RIBBING

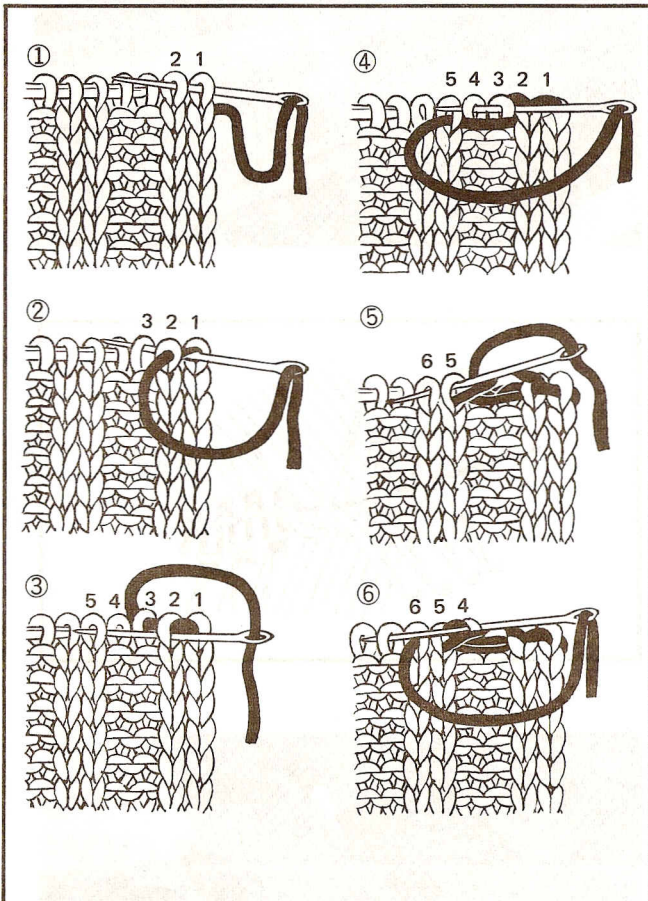

1. Cut the yarn end about three times as long as the width of the knitting. Thread yarn end into tapestry needle.

2. Pass the needle through the stitches following above figures.

\*Do not pull thread through too tightly for the neat finish.

## 8. PARTIAL KNITTING

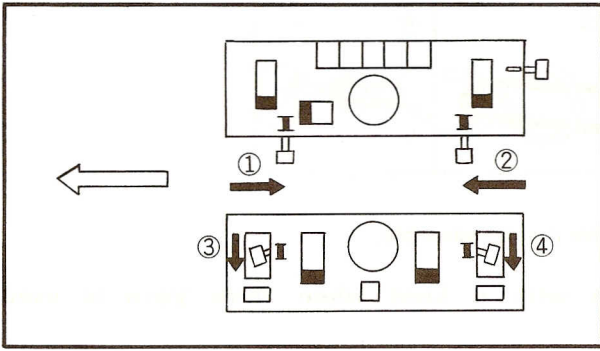

FOR 1 X 1 Rib, 2 X 2 Rib, and Close Rib

### KNITTING NARROWER

1. **Setting carriages**  
Main carriage . . . . . Both Partial Knitting  
Levers on "I" ① ②.  
Rib carriage . . . . . Both Partial Knitting  
Levers on "I" ③ ④.

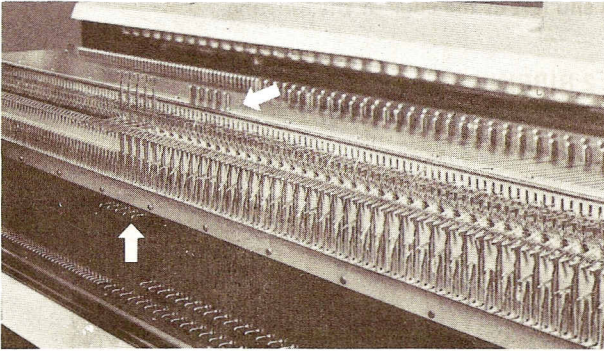

2. Select required number of needles at the opposite end to carriage, to "E" position. (ex. 5 needles on each bed).
3. Knit one row to the left.  
(The yarn end passes over the needles in "E" position.)

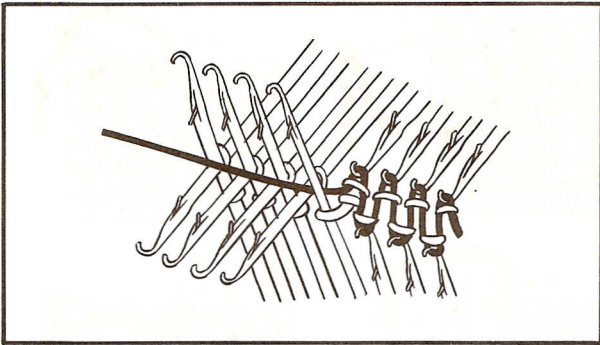

4. Pass the yarn end under the first end needle in "E" position, then pass it over the rest (see Fig.)

5. Knit the second row to the right.

Repeat above steps from 2 through 5.

### KNITTING WIDER

1. Set carriages same as above for KNITTING NARROWER.  
Assume some of needles are already in "E" position in this case.

2. Push back required number of needles to be knitted wider, to "D" position.

3. Knit one row to the left.

4. Pass the yarn end under the first end needle in "E" position, then pass it over the rest (see above Fig.)

5. Knit the second row to the right.

Repeat steps from 2 through 5.

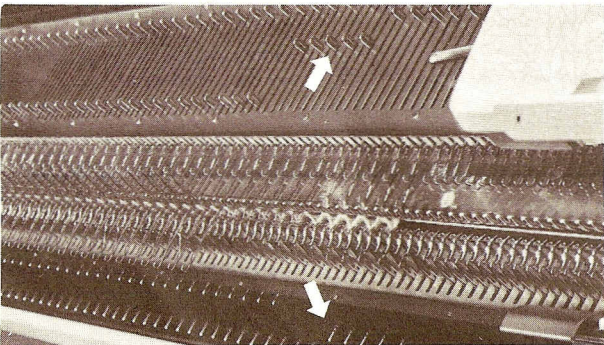

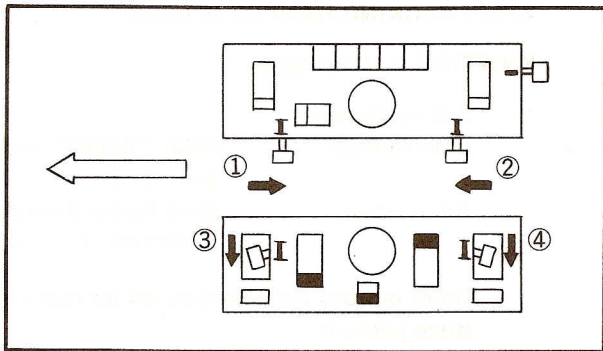

## PARTIAL KNITTING

WHEN TUCK OR EMPTY BUTTONS ARE USED

### KNITTING NARROWER

#### Setting Carriages

Main carriage . . . . . Both Partial Knitting  
Levers on "I" ①②.  
Rib carriage . . . . . Both Partial Knitting  
Levers on "I" ③④.  
Other buttons and  
levers are set for  
required stitch  
pattern.

Then follow steps of 1 X1-rib on page 29.

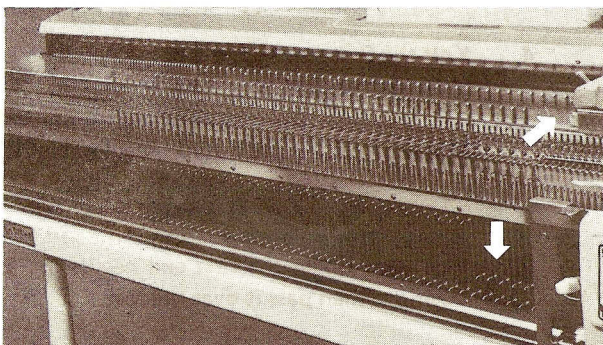
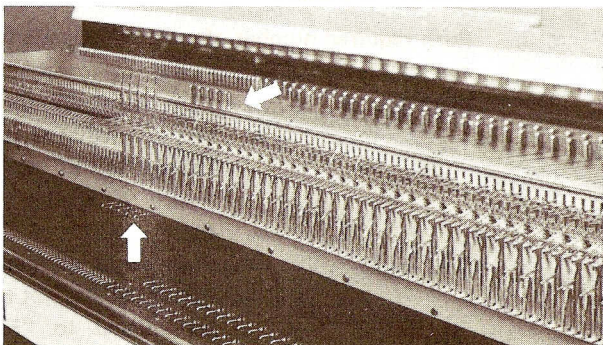

### KNITTING WIDER

1. Set carriage same as above for KNITTING NARROWER.  
Assume some of needles are already in "E" position in this case.
  2. Using transfer tool, push required number of needles to be increased from "E" to "B" position.
  3. Knit one row to the left.
  4. Pass the yarn end under the first end needle in "E" position, then pass it over the rest.
  5. Knit the second row to the right.
- Repeat steps from 2 through 5.



## PARTIAL KNITTING

### WHEN RACKING HANDLE IS USED

#### KNITTING NARROWER

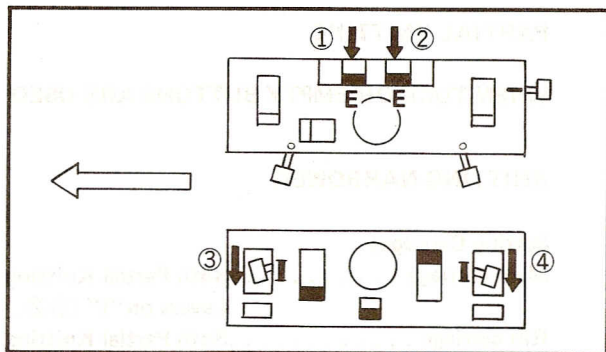

- Setting Carriage**  
 Main carriage . . . . . Both "Empty" buttons ① ②.  
 Rib carriage . . . . . Both Partial Knitting Levers on "I" ③ ④.

Other buttons and levers are set for required stitch patterns.

- Move Racking Handle** following the instruction of the pattern.

- Push required number of needles opposite to carriage.**

**Main knitter . . . . .** Push required number of needles to be knitted to "E" position. (Ⓐ needles in Fig.)

**Ribber . . . . .** Push required number of needles not to be knitted to "E" position.  
(ex. 5 needles Ⓑ needles in Fig.)

- Knit the first row to the left.**  
**Main knitter . . . . .** The needles in "E" position are knitted.

**Ribber . . . . .** The needles in "E" position are not knitted.

- Pass yarn under the first end needle in "E" position, then pass it over the rest.**

- Again, push the needles to be knitted on main knitter to "E" position.**

- Knit the second row to the right.**  
**Repeat the above steps from 2 through 7.**

#### KNITTING WIDER

Follow above steps except step 3.

Assume some needles are already in "E" position.

- Main knitter . . . . .** Push required number of needles to be knitted to "E" position.

**Rib knitter . . . . .** Using transfer tool, push back required number of needles to "B" position.

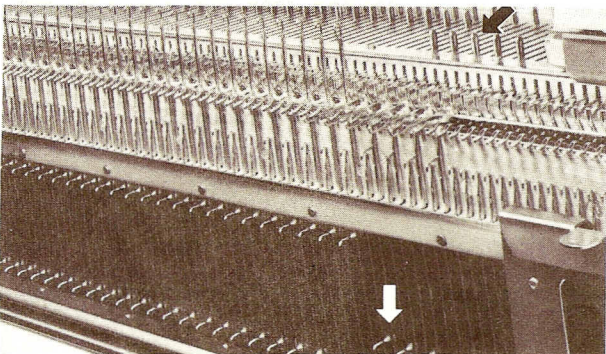
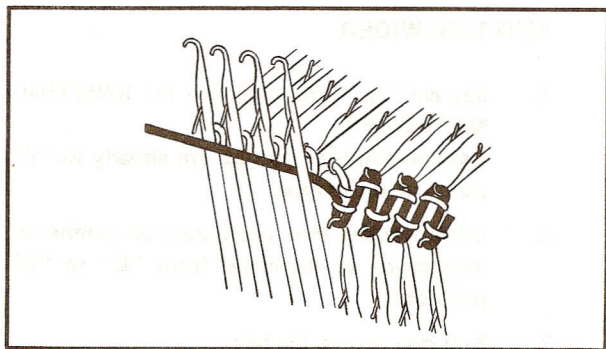
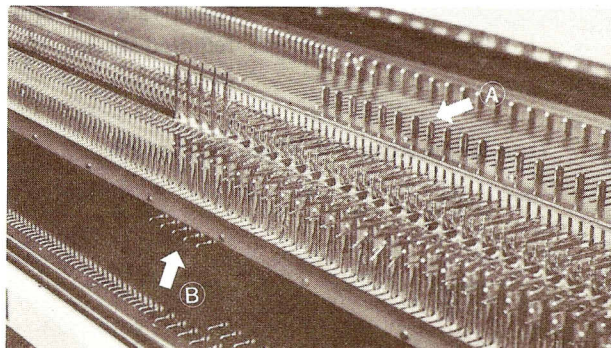

## 9. HOW TO FIX THE MACHINE

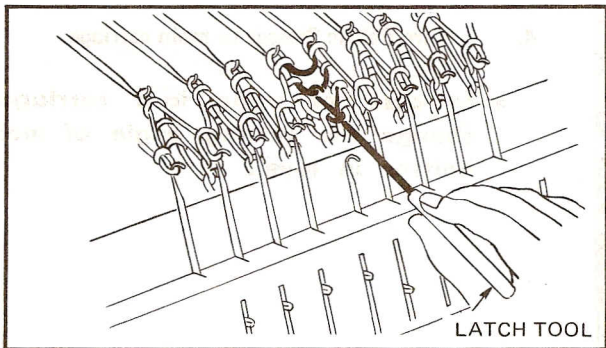
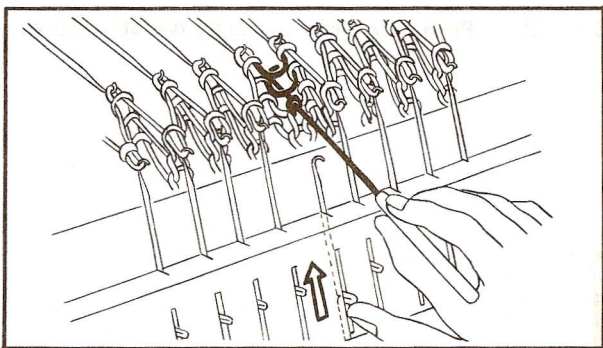
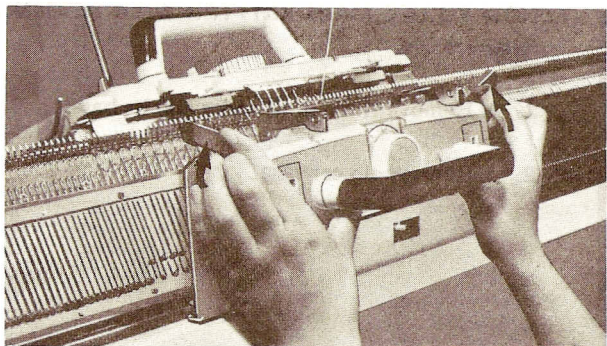
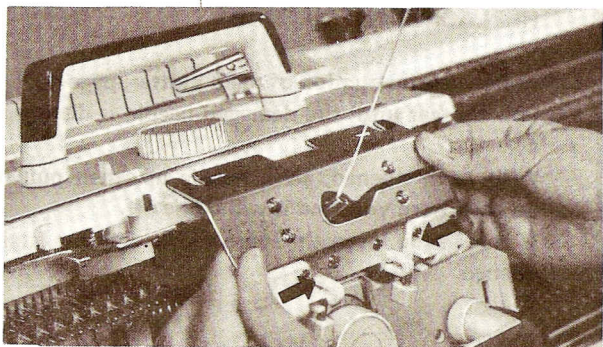

### CARRIAGE JAMMING

1. Do not move carriages by force.  
Loosen Fabric Presser Knobs and remove Rib Yarn Feeder.  
\* Do not pull it up.  
Take it off pulling towards you.
2. Pull both Front Holders of rib carriage, and while holding them, tilt carriage toward you. Slide it off the working section.

Then make the same procedure as for main carriage.

3. Using transfer tool, settle down all the stitches in "B" position.
4. Unravel the stitches up to the end near carriage.

\* When a punch card is used with, refer to the instruction of main knitter on page 41.

### DROPPED STITCHES

Remove knitting weights to prevent more stitches being dropped.

Disengage both Metal Pins from Carriage Guide (refer to page 33).

Drop down ribber by one stage by pushing drop levers at the both sides.

#### Dropped one row

Pick up the dropped stitch onto the needle using Pick-up Hook (refer to Instruction book of main knitter, page 45).

#### Dropped several rows

Pick up the stitches from the bottom up to the top using latch tool (see Fig.)

When a stitch on main knitter is dropped, use latch tool from the back.

When a stitch on ribber is dropped, use latch tool from the front.

5. Put back the stitch on the empty needle.  
The stitch is fixed.

## REPLACING THE NEEDLE

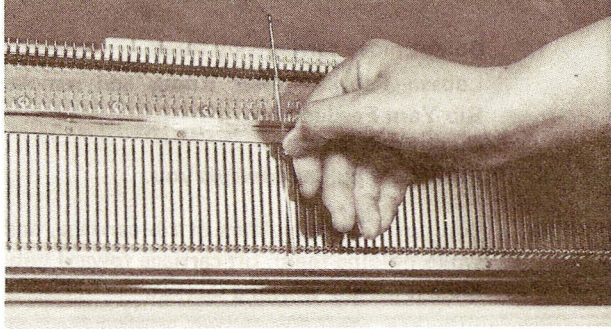

Follow the instruction of main knitter, page 44. Pull the bar until the damaged needle is disengaged.

With latch opened, push needle up, then pull it down toward you, and it will come off.

It is easier to insert the spare needle with the latch opened.

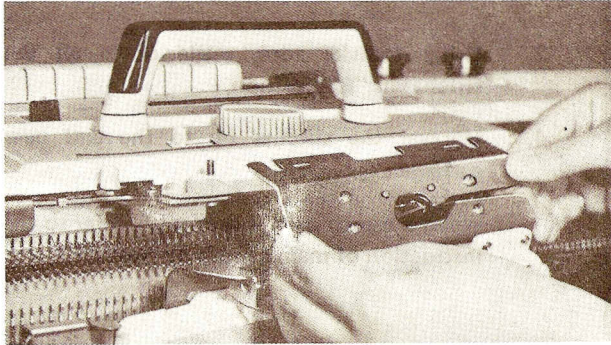

## HOW TO USE MAIN KNITTER WITH SETTING RIBBER ON.

1. Remove Rib Yarn Feeder and its base.

2. Remove rib carriage.

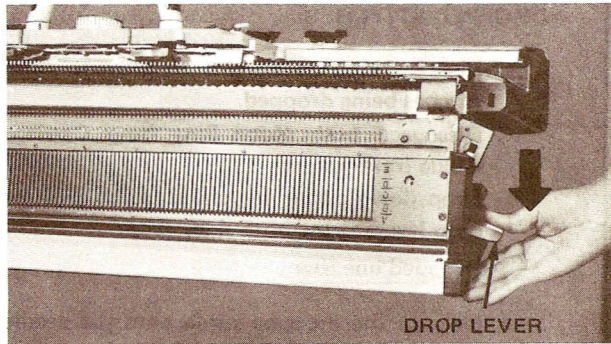

3. Push both Drop Levers by two steps down.

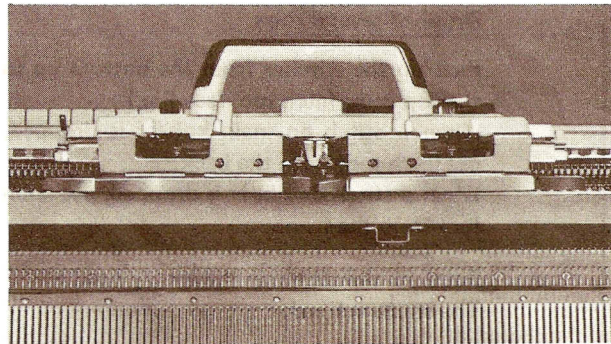

4. Secure Fabric Presser to main carriage.

\* In case of using lace carriage, change the setting angle of main knitter in level.

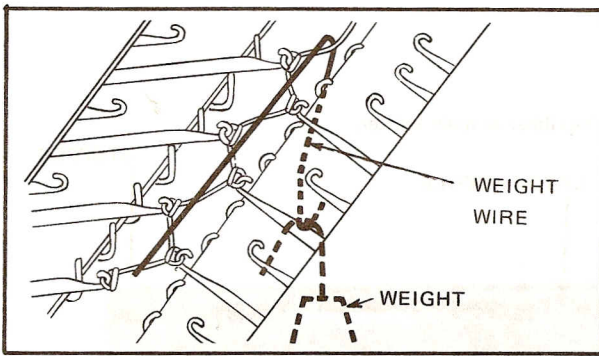

## WHEN END STITCHES ARE NOT KNITTED

1. When a few stitches at both ends come up, keep re-hanging side weights every ten or fifteen rows.

When stitches at one side come up, be sure weights are well balanced.

2. In case that all stitches come up, add more weights on.
3. If some stitches come up in partial knitting, hang casting-on comb of main knitter and weights over these stitches.

## HOW TO MOVE CARRIAGE WITHOUT KNITTING

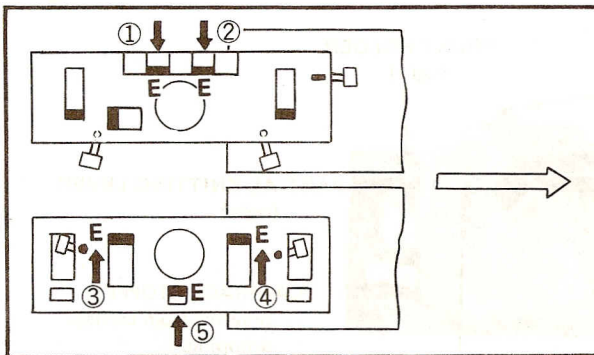

Set every Empty buttons in ( ① ② ③ ④ ⑤ ), then slide carriage to the other side with Tension Dials at "0".

## HOW TAKE OFF THE KNITTED PIECE

### With Waste Knitting

Knit more than six rows of waste knitting with contrast coloured yarn.

Remove weights.

Unthread yarn from the yarn feeder.

Run carriage, and the knitted piece will drop off.

### With Knitting Needle

Transfer all the stitches on ribber to main knitter, then pick up all of them onto either knitting needle or casting-on wire.

# 10. NAMES AND FUNCTION

## RIB KNITTER

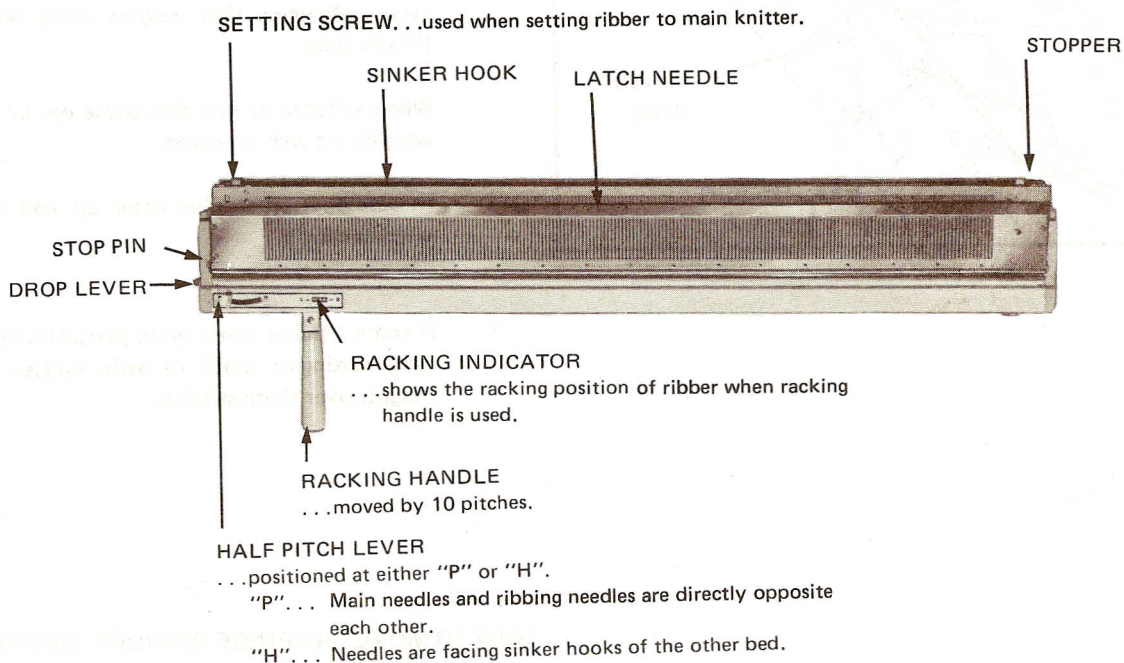

## RIBBING CARRIAGE

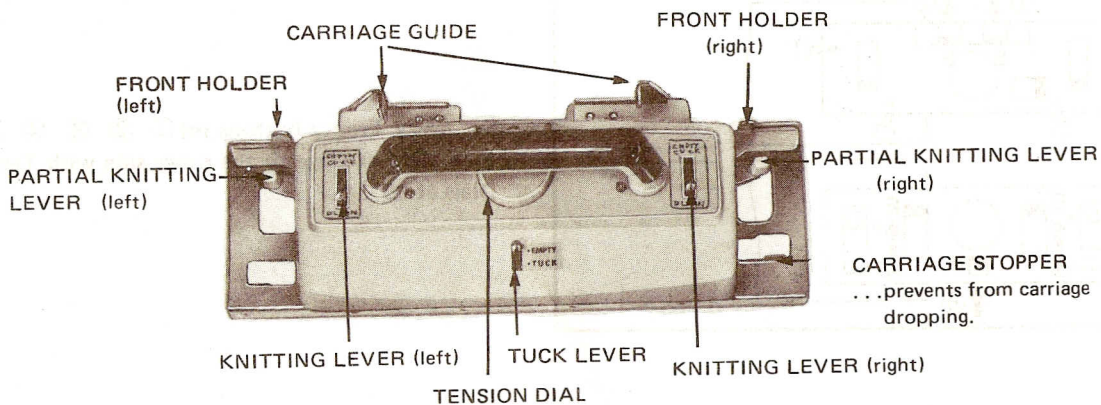

## RIB YARN FEEDER

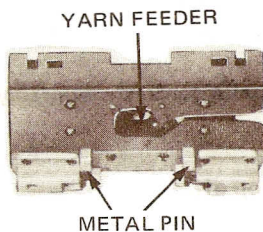

## RIB YARN FEEDER BASE



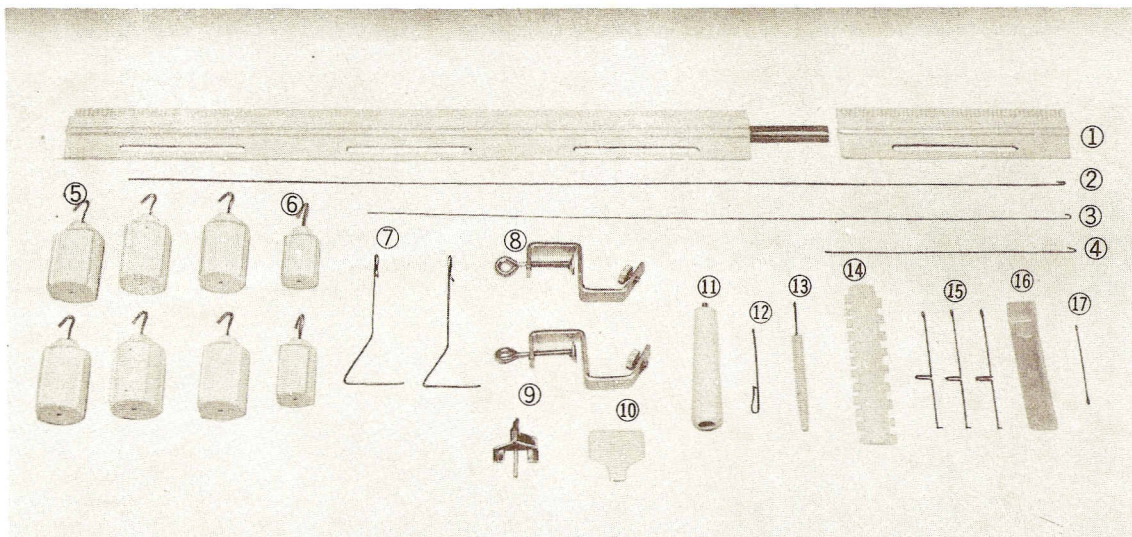

1. Cast-on Comb . . . . .used when starting knitting
- 2 Cast-on Comb Wire(long) . . . . .used together with cast-on comb
- 3 Cast-on Comb Wire (medium)
- 4 Cast-on Comb Wire(short)
5. Large Knitting Weights . . . . .used for getting better condition for smooth knitting
6. Small knitting Weights . . . . .used for getting better knitting condition of the end stitches and partial knitting
7. Side Weight Hooks. . . . .used when hanging small weights on the edges of the knitting fabric
8. Clamps . . . . .used for setting main knitter on a table
9. Take-up Rod Support. . . . .used when standing Take-up Rod on main bed
10. Driver Plate . . . . .used when setting and removing ribber from main knitter
11. Racking Handle. . . . .used when racking ribber to the right or left
12. Threader . . . . .used for easy and quick threading of yarn
13. Pick-up Hook . . . . .used for picking up a dropped stitch
14. Selector Comb (2x1, 2x2). . . . .used for selecting needles
15. Spare Latch Needles. . . . .used for replacement of damaged latch needles, see page 33
16. Latch Needle Bag
17. Double-Eyed Transfer Tool. . . . .used when transferring stitches between two beds, see page 27