

TOYOTA
KR501

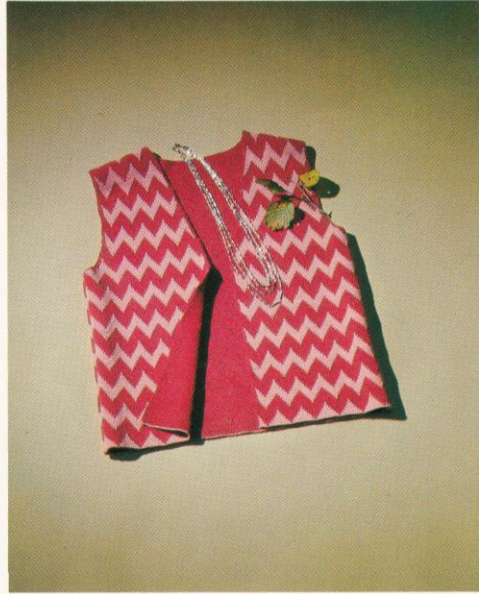
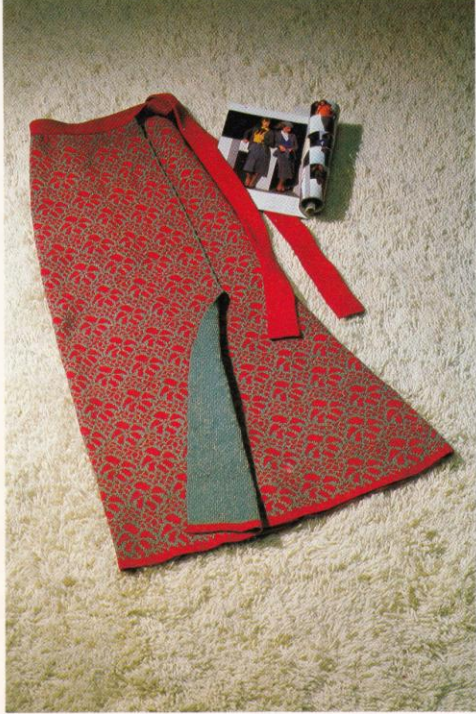

Instructions P53—P56

CONTENTS

NAMES OF PARTS	2
SETTING UP.....	6
BASIC RIB KNITTING	
1x1 RIB AND CAST ON	10
2x2 RIB AND CAST ON	13
CLOSE RIB AND CAST ON	17
CIRCULAR KNITTING AND CAST ON.....	18
PATTERN RIB	
SINGLE FISHERMAN'S RIB.....	20
DOUBLE FISHERMAN'S RIB.....	20
RIPPLING.....	21
SWINGING RIB	22
CABLE KNITTING	23
TUCK PATTERN RIB	24
CHECKERED FISHERMAN'S RIB.....	25
PATTERN RIB WITH PUNCH CARDS	
HONEY COMB PATTERN.....	26
PIN TUCK KNITTING	27
CASTING OFF	28
SIMULKNIT	
CAST ON	29
CASTING OFF.....	31
TECHNIQUES FOR MAKING GARMENTS	
INCREASE (1 stitch, several stitches)	32
DECREASE (1 stitch, several stitches)	33
PARTIAL KNITTING (bust darts)	35
PARTIAL KNITTING (reversed darts)	36
PARTIAL KNITTING (when racking handle is used)	37
BUTTONHOLE	38
EYELET BUTTONHOLE	39
SEAMING	39
TECHNIQUES FOR MAKING GARMENTS BY SIMULKNIT	
INCREASE (1 stitch, several stitches).....	40
DECREASE (1 stitch, several stitches)	41
PARTIAL KNITTING (bust darts)	42
PARTIAL KNITTING (reversed darts)	43
SHOULDER SEAMING	44
TO MAKE REVERSIBLE GARMENTS	45
TECHNICAL HINTS	
CARRIAGE JAMMING	47
CARRIAGE JAMMING IN PUNCH CARD KNITTING	48
HOW TO USE DOUBLE-EYED TRANSFER TOOL	49
DROPPED STITCHES.....	49
HOW TO USE MAIN KNITTER AFTER RIBBING.....	50
TENSION SWATCH.....	50
CHANGING NEEDLES	51
HOW TO USE SMALL WEIGHTS	51
HOW TO USE YARN HOLDER SLOT.....	51
PROPER CARE OF THE MACHINE.....	52
MAKE YOUR GARMENTS BY SIMULKNIT	53
WAISTCOAT.....	53
FULL-LENGTH SKIRT	54
SHOULDER BAG.....	56

NAMES OF PARTS

RIB BED

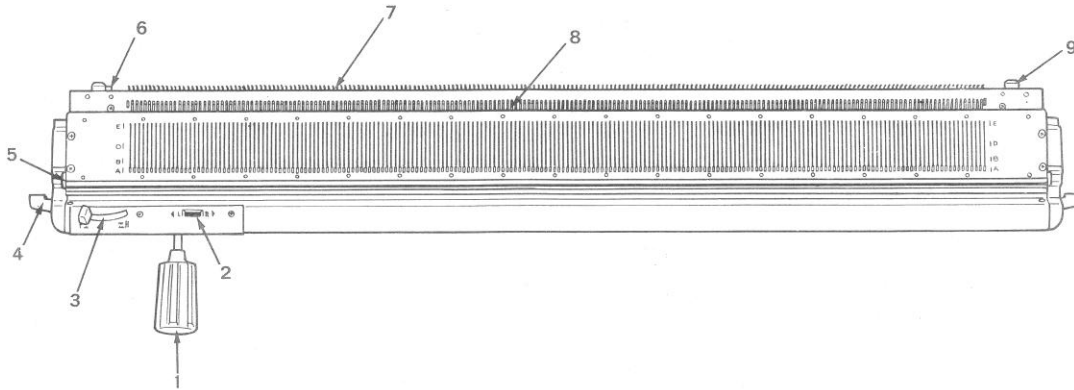

1 Racking Handle

Turn to right or left to move ribber sideways.

2 Racking Indicator

Tells direction of the racking movement and the position of rib bed in relation to main bed.

3 Half Pitch Lever



P... Needles on both beds face each other point to point.

H... Needles on ribber are moved by a half pitch.

4 Drop Levers

Push down with drop levers on both sides to lower the ribber.

To raise the ribber, push up the ribber from its bottom so that the ribber will be set up automatically.

5 Stop Pins

Prevents carriage from falling off from the bed.

6 Setting Screws

In order to attach ribber to main bed.

7 Sinker Hooks

8 Latch Needles

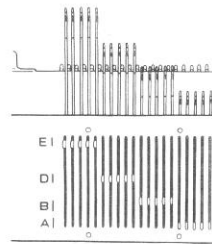

A... Non-working position

B... Working position

D... The needles come to this position when doing Simul-knit.

E... Holding position for partial knitting

9 Stopper

When attaching ribber onto main bed, stopper should touch main bed lightly.

RIB CARRIAGE

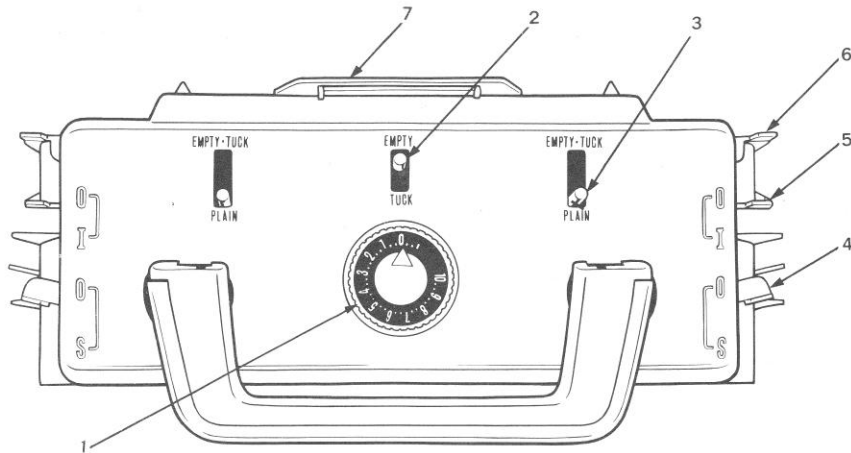

1 Tension Dial

Regulates the stitch size i.e. higher the number, larger the stitch; lower the number, smaller the stitch.

2 Centre Lever

Decides selection "TUCK" or "EMPTY" with E-T levers.
Set it to "EMPTY" except tuck pattern knitting.

3 E-T Levers

EMPTY... Needles in D and E positions are knitted.
TUCK... positions are knitted.

PLAIN... Set at Plain knitting or Simulknit.
Needles in B, D and E positions are knitted.

4 Simulknit Lever (S lever)

Set to S for doing "Simulknit".
For ordinary knitting set to "0".

5 Partial Knit Lever

Set to "I" for partial knitting.
For ordinary knitting set to "0".

6 Front Holders

Pull upwards to place carriage on bed or to remove.

7 Carriage Guide

To be connected to coupling.

Coupling

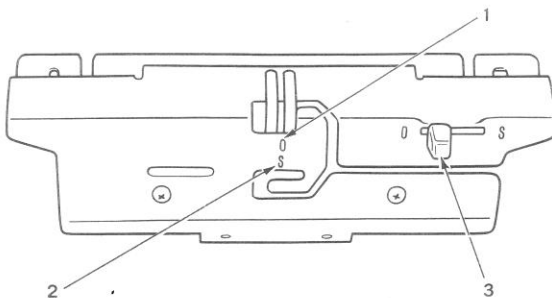

1 Feeder 0

For main yarn (col. 1)

2 Feeder S

For "Simulknit"
S yarn (col. 2) is threaded here.

3 Simulknit Lever (S lever)

Set to S for doing "Simulknit".
For ordinary knitting set to "0".

ACCESSORIES

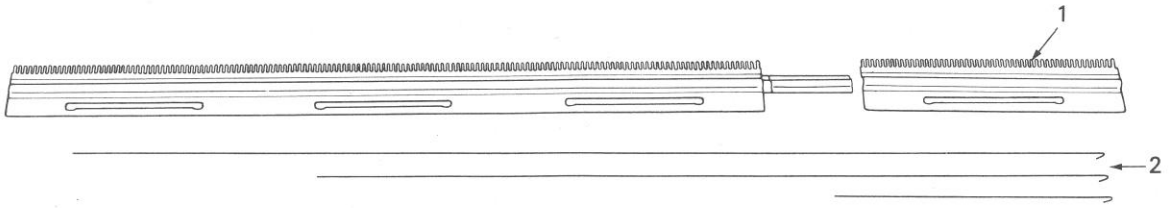

1 Cast on Comb (can be separated into two parts)

Used when starting to knit.

2 Cast on Comb Wire long
medium
short

Used with cast on comb when starting to knit.

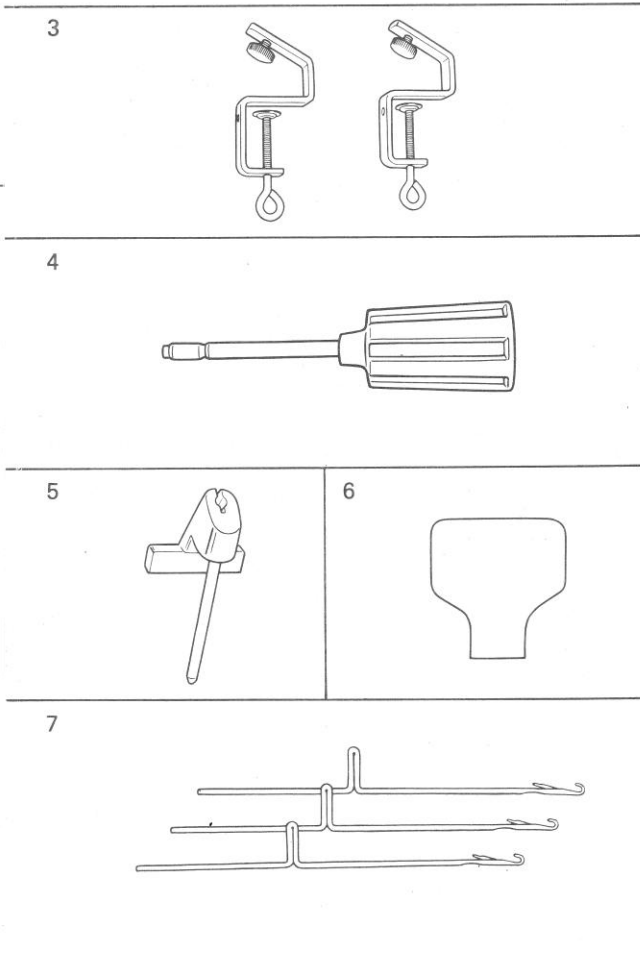

3 Clamps

To secure main knitter to table.

4 Racking Handle

Moves ribber sideways.

5 Tension Rod Base

Used to fix upper tension rod to main bed.

6 Screwdriver

Used on setting screws when attaching or detaching ribber.

7 Spare Latch Needles

8

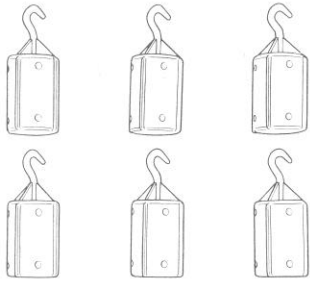

8 Large Weights

Hook them all the time at the holes of Cast on comb in order to obtain smooth knitting conditions.

9

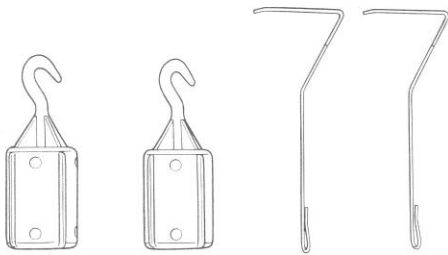

9 Small Weights and Weight Hooks

Hook at sides of knitting to prevent edge stitches from dropping.

10



11

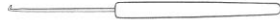

10 Double-Eyed Transfer Tool

In order to transfer stitches from one bed to the other.

11 Pick-up Hook

To pick up dropped stitches.

12



12 Threader

To thread a yarn into feeder.

13

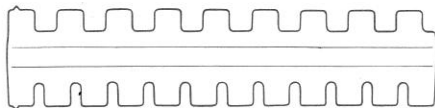

13 Selector Comb 2x1
2x2

To select needles.

SETTING UP

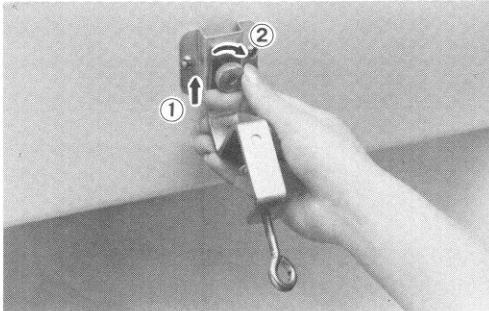

Remove main carriage from the bed.
Insert clamp screws into slots of brace on underside of main knitter.
Slide it upward. ①
Tighten screw. ②

* Slot and a clamp screw should be parallel.

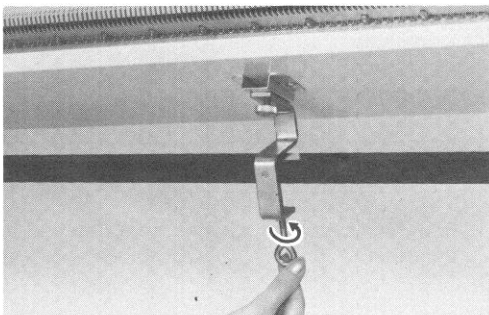

Place main knitter on table.
Tighten clamps to table.

There should not be any gap between clamp and table edge.

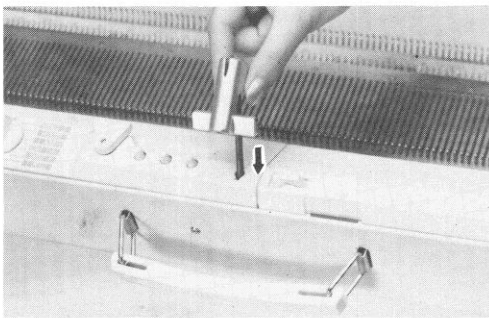

Insert tension rod base into rear of main knitter.

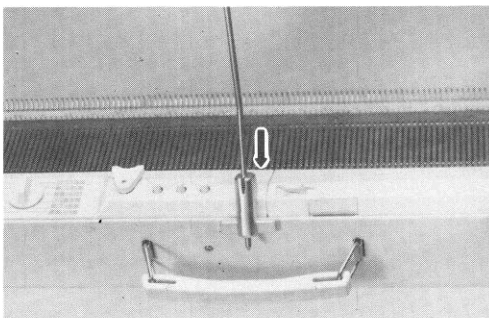

Insert angled end of tension rod into tension rod base.

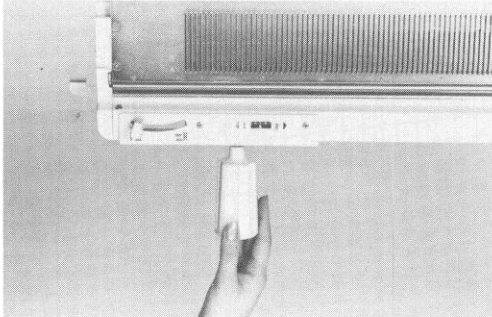

Push racking handle into hole at left hand side of ribber, twisting gently until completely home.

A "click" will be heard when handle is caught properly.

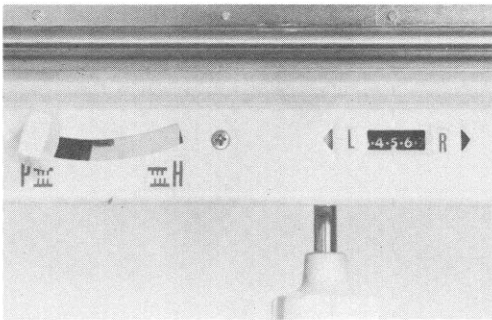

Set Half pitch lever to P, and Racking indicator to 5.

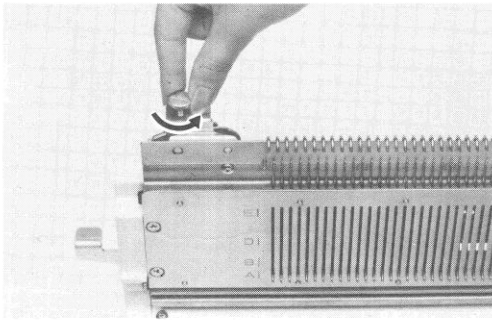

Loosen setting screws on both sides and remove from ribber.

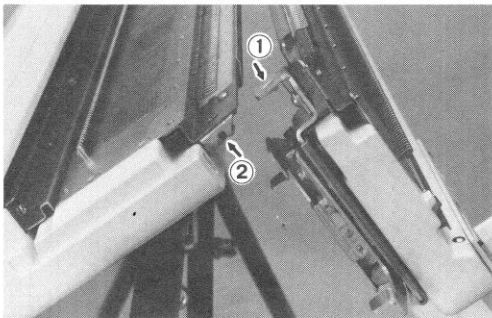

Hang the hooks ① at both ends of ribber to Yarn End Holders ② on main bed.

To prevent the needles from being damaged, be sure to set all needles on both beds to A position.

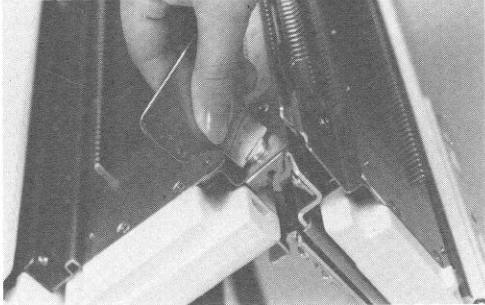

Holding ribber steady with hand, place left stopper of ribber to main bed, and tighten setting screw using screwdriver.

* A gap between stopper and the front of the main knitter will cause improper gauge in knitting or dropping stitches.

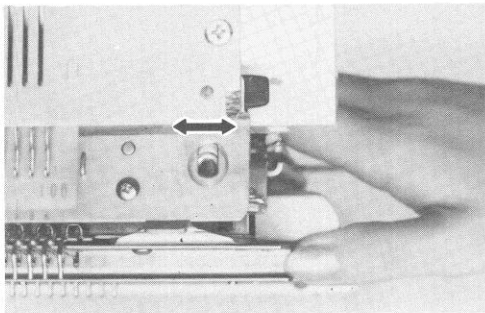

While holding ribber, adjust the plate at right side of ribber so that screw holes are aligned.

Tighten screw placing right stopper of ribber to main bed.

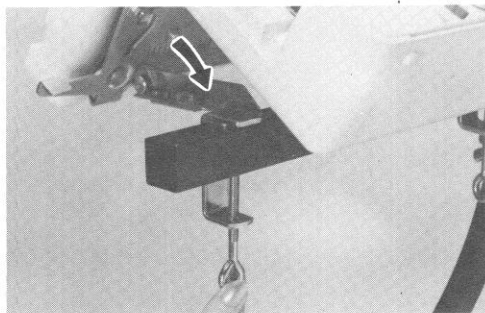

Pull down fixing plates.

Fix them on both sides to table with clamps of main knitter.

Tighten screws.

* Do not force fixing plates towards table.

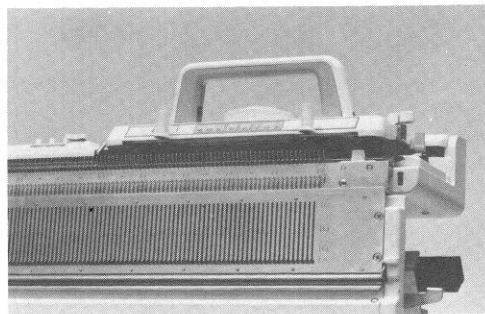

Set all needles on both main and rib beds to A position.

Set main carriage on main bed.

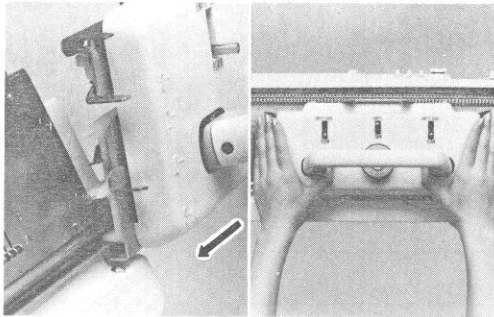

Raise handle on rib carriage.

Tilt and slide rib carriage in along back rail of bed by fitting the bottom of carriage, ensuring it doesn't hit stop pin.

Pass the carriage over stop pin, and pull up front holders on both sides of carriage and fix top of carriage to front rail.

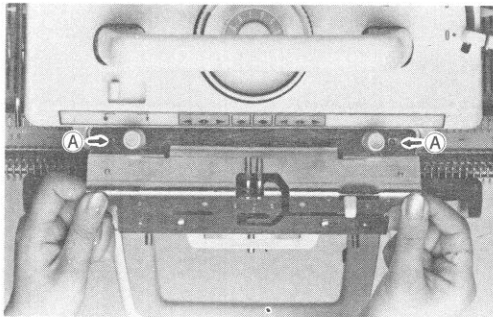

Place both carriages exactly facing each other. Loosen two thumb screws of main carriage.

Place two cutouts of coupling into round screws of main carriage so that two holes (A) of coupling will fit to pegs of main carriage.

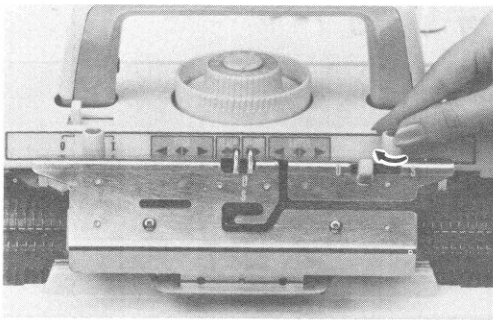

Push lightly downwards on coupling to ensure it is completely in carriage guide of rib carriage.

Tighten thumb screws.

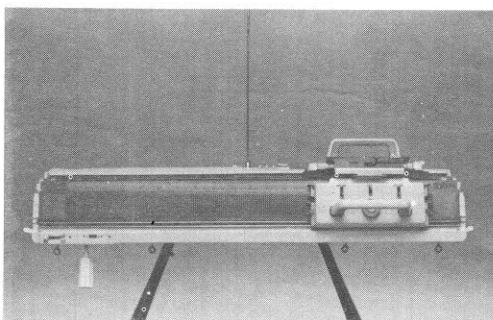

The machine is now ready for use.

* Place paraffin wax on upper tension unit.

BASIC RIB KNITTING

1X1 RIB

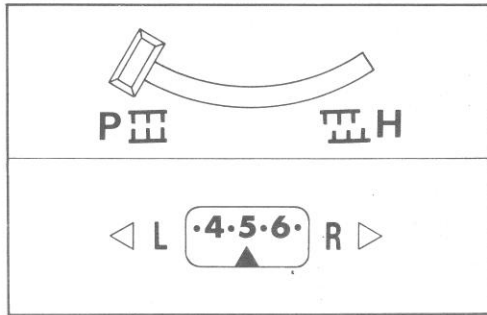
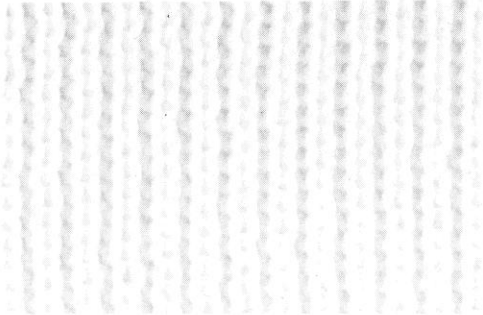

Method I (with easy cast on)

- 1 Set Half pitch lever and Racking indicator.

Push back all needles to non-working position. (A position)

Half pitch lever P
 Racking indicator . . .
 Carriages are at right.

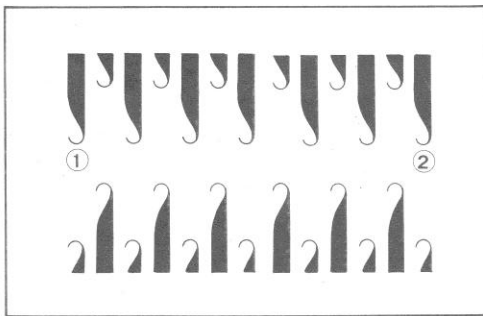

- 2 Set needles at B position as shown.

* End needles (① ②) should be on main bed.
 * When more than 180 needles are used, attach extension rails.

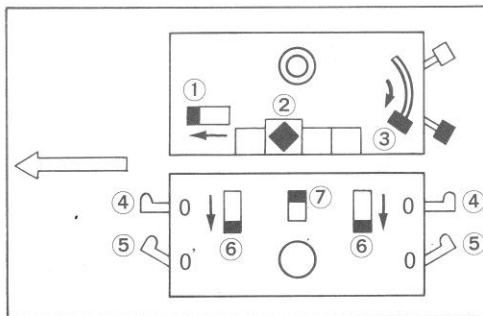

- 3 Set carriages (for plain knitting).

Main . . . ①, ② (PLAIN ◆), ③
 Rib . . . ④ ⑤ (0), ⑥
 ⑦ (EMPTY)

Set S lever on Coupling to 0.

- 4 Set tension dials.
 (e.g. medium 4ply . . . $\frac{0}{0}$)

* Set upper tension dial between “ $\frac{+}{-}$ ” and “-”.
 * Use paraffin wax.

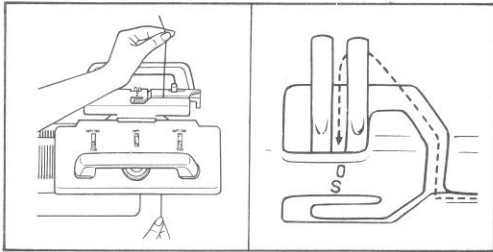

- 5 Thread yarn through tension unit.

Slide carriages to right until feeder comes out of bed. Hold yarn top with left hand, yarn end with right hand. Pass yarn to the space between carriages, then under metal pin to feeder. Push yarn end to left so that a "click" will be heard when yarn is caught properly.

- * You can also thread yarn using Threader.
- * Make sure yarn is caught in the feeder.

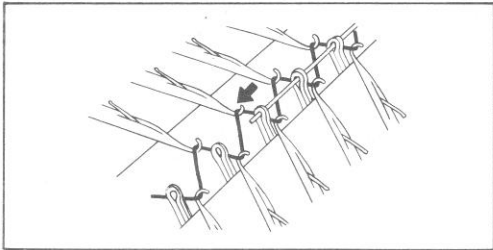

- 6 Holding yarn end by hand or at yarn holder slot (page 51), move carriages to left. Move carriages slowly, pushing them down.

- 7 Pull out wire from cast on comb.

Push up teeth between beds from bottom of machine through stitches. Insert wire to hang comb on stitches.

Remove yarn end from yarn holder slot.

- 8 Hang weights on comb for balance.

GUIDE TO WIDTH OF KNITTING AND THE WEIGHT
(In close rib with medium 4 ply)

TOTAL NO. OF WORKING NEEDLES	NO. OF REQUIRED WEIGHTS
UP TO 30sts	1
30sts ~ 60sts	2
60 ~ 90	3
90 ~ 120	4
120 ~ 150	5
150 ~ 200	6

Number of required weights will be different according to yarns and stitch patterns.

- 9 Carriages are at left. Re-set carriages.

Main ... ① (EMPTY ◀)
Rib ... ② ③ (EMPTY)

- 10 Knit 3 rows changing both tension dials. (e.g. medium 4 ply ... $\frac{2}{0}, \frac{2}{2}, \frac{2}{2}$)

CAST ON is now COMPLETED.

- 11 Re-set carriages.

Main ... ① (PLAIN ◆)
Rib ... ② (PLAIN)

Continue ribbing.

- * Try not to knit knots.

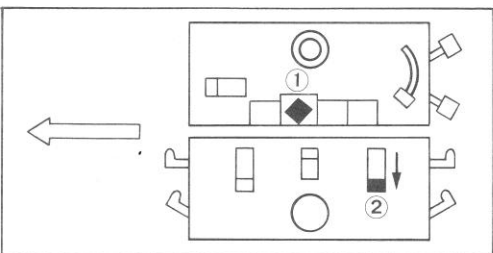
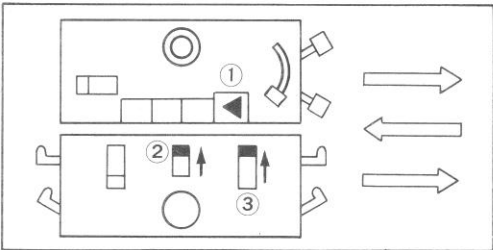
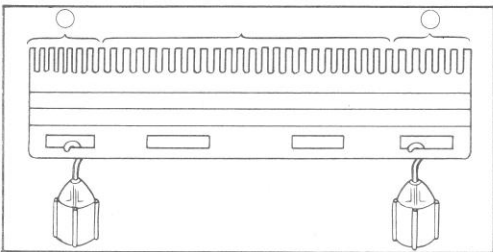

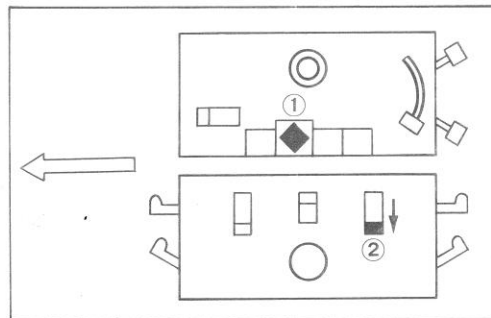
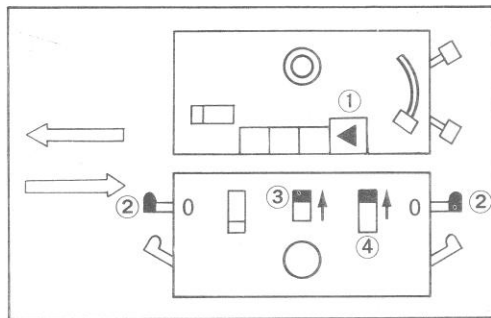
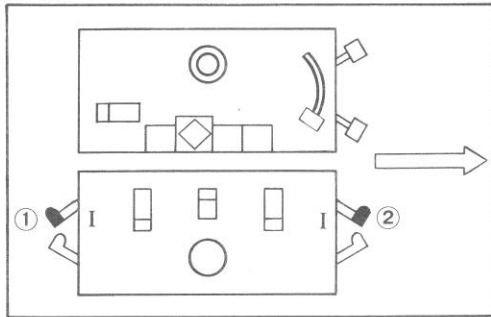
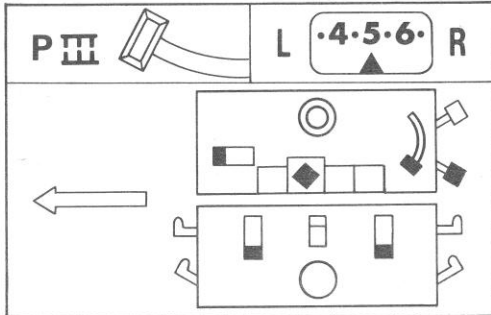

Method II (with tighter edge cast on)

1-3 Follow steps 1—3 of "Method I" (page 10).

4 Set tension dials.

Set them on both carriages by one number looser than shown on table for the first row of "1x1 rib".
(e.g. medium 4ply . . . $\frac{1}{1}$)

5 Thread nylon cord into feeder 0 and knit one row to left.
Remove it from feeder.

6 Hang cast on comb and weights.

7 Pull out all needles on ribber to E position.

8 Re-set rib carriage . . . ① ② (I)

9 Thread main yarn into feeder 0.
Change tension dial and knit second row to right.

10 Re-set carriages.

Main . . . ① (EMPTY ◀)

Rib . . . ② (0)

③ ④ (EMPTY)

11 Knit two more rows with the same tension dials.

CAST ON is now COMPLETED.

12 Re-set carriages.

Main . . . ① (PLAIN ◆)

Rib . . . ② (PLAIN)

13 Set tension dials for "1x1 rib".
(e.g. medium 4ply . . . $\frac{2}{2}$)
Continue ribbing.

14 After completing ribbing, remove cast on comb and weights.
Pull out nylon cord after pressing.

2x2 RIB

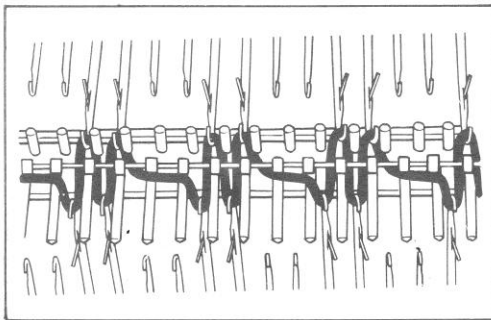
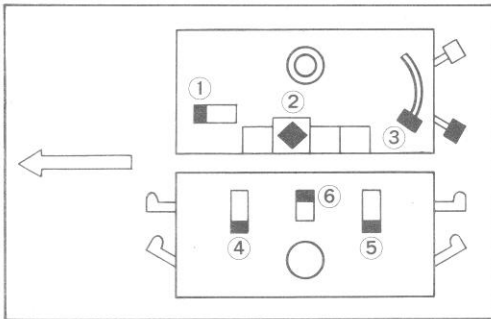
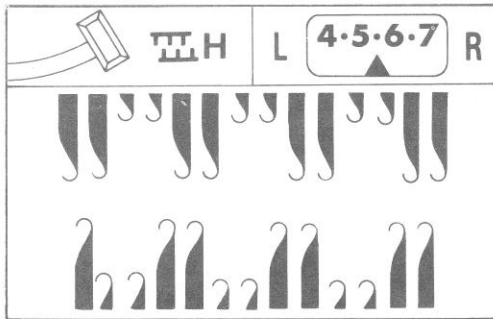
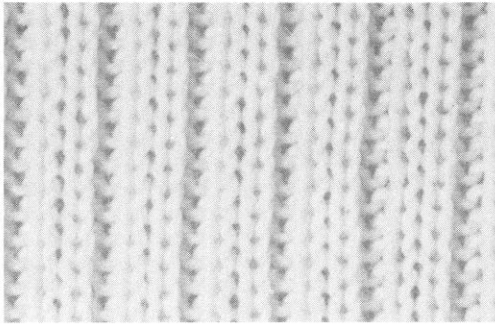

Method I (easy way)

- 1 Half pitch lever H
Racking indicator . . . 5 6
Carriages are at right.
- 2 Set needles as shown.

- 3 Set carriages.
Main . . . ①, ② (PLAIN \blacklozenge), ③
Rib . . . ④ ⑤ (PLAIN), ⑥ (EMPTY)

* For tighter edge cast on, follow steps 4-11 on page 12.

- 4 Set tension dials.
(e.g. medium 4ply . . . $\frac{2}{2}$)

- 5 Thread yarn into feeder 0.
- 6 Knit first row to left.
See how yarn is hooked.
- 7 Hang cast on comb and weights so as to be balanced.

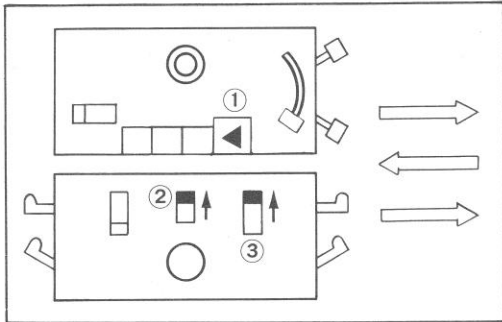

8 Re-set carriages.

Main ... ① (EMPTY ◀)
Rib ② ③ (EMPTY)

9 Knit 3 rows changing both tension dials.
(e.g. medium 4ply ... $\frac{4}{2}, \frac{4}{4}, \frac{4}{4}$)

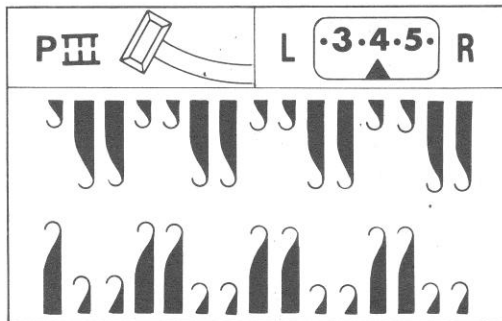

10 Re-set Half pitch lever to P.

Half pitch lever P
Racking indicator ... 5

11 Turn racking handle one pitch to left.
Racking indicator ... 4

* Check the position of needle.

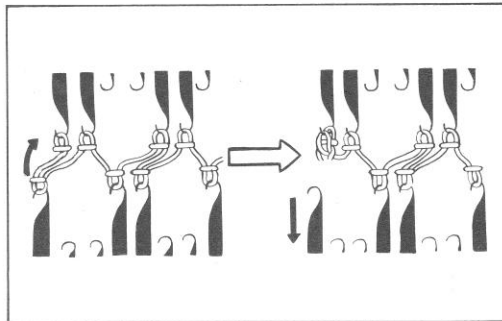

12 Transfer left end stitch on ribber to left end needle on main knitter.

13 Push back empty left end needle on ribber to A position.

CAST ON is now COMPLETED.

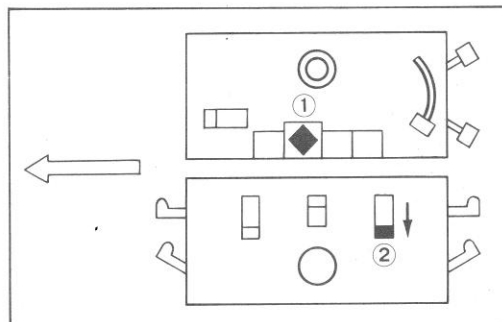

14 Re-set carriages.

Main ... ① (PLAIN ◆)
Rib ② (PLAIN)

Continue ribbing.

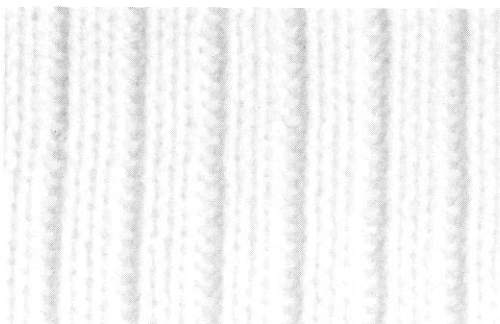

Method II (tighter type)

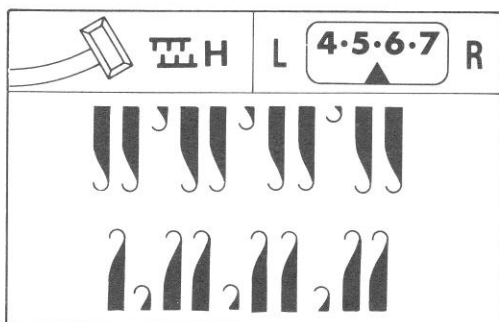

- 1 Half pitch lever H
Racking indicator . . . 5-6
Carriages are at right.

- 2 Set needles as shown.

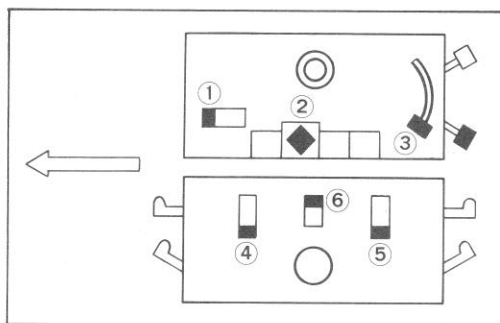

- 3 Set carriages.

Main . . . ①, ② (PLAIN \blacklozenge), ③
Rib . . . ④, ⑤ (PLAIN), ⑥ (EMPTY)

- 4 Set tension dials.
(e.g. medium 4ply . . . $\frac{0}{0}$)

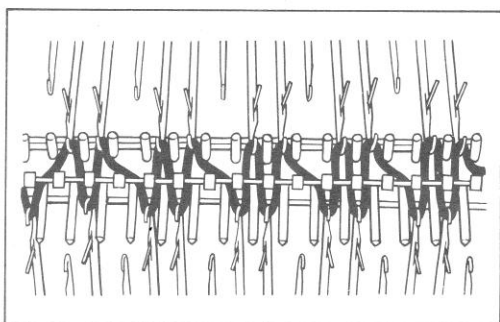

- 5 Thread yarn into feeder 0.

- 6 Knit first row to left.
See how yarn is hooked.

- 7 Hang cast on comb and weights so as to be balanced.

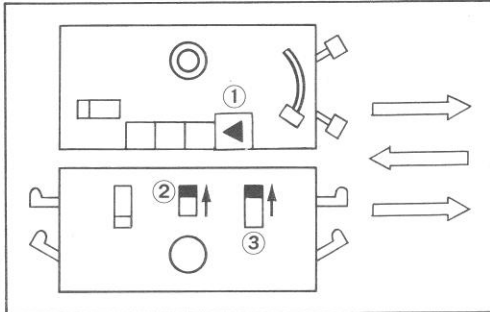

8 Re-set carriages.

Main ... ① (EMPTY ◀)
 Rib ② ③ (EMPTY)

9 Knit 3 rows changing both tension dials.

(e.g. medium 4ply ... $\frac{4}{0}, \frac{4}{4}, \frac{4}{4}$)

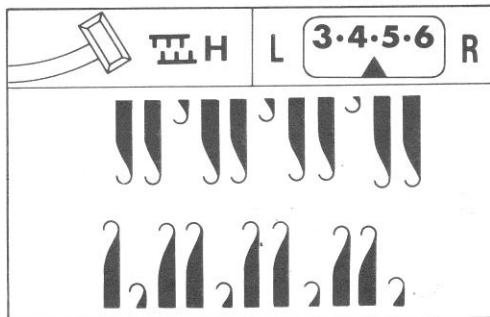

10 Turn racking handle one pitch to left.

Half pitch lever H
 Racking indicator ... $\boxed{4, 5}$

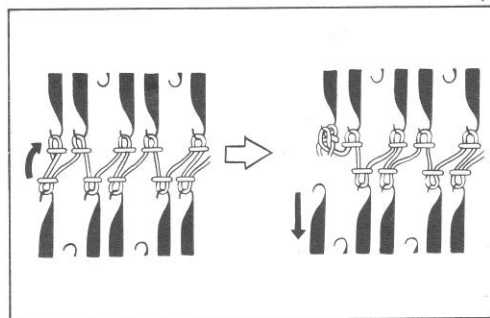

11 Transfer left end stitch on ribber to left end needle on main knitter.

12 Push back empty left needle on ribber to A position.

CAST ON is now COMPLETED.

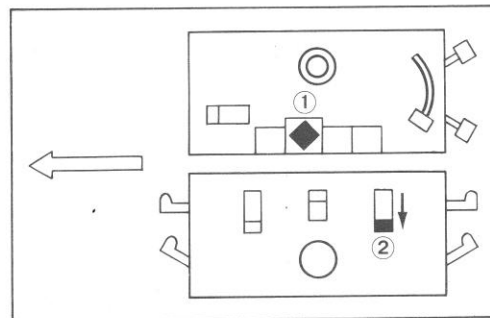

13 Re-set carriages.

Main ... ① (PLAIN ◆)
 Rib ② (PLAIN)

Continue ribbing.

CLOSE RIB

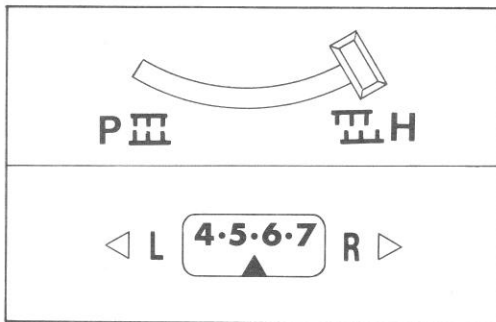
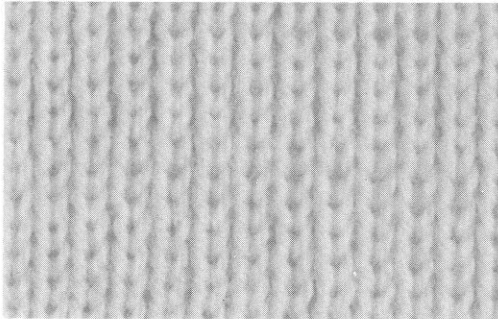

- 1 Half pitch lever H
Racking indicator . . . 5 6
Carriages are at right.

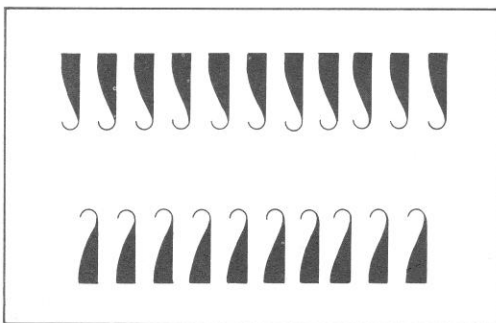

- 2 Set needles as shown.
- 3 Follow steps 3–9 of "1x1 rib cast on" on pages 10–11.
- 10 Knit 3 rows changing both tension dials.
(e.g. medium 4ply . . . $\frac{1}{1}$, $\frac{4}{1}$, $\frac{4}{4}$)
CAST ON is now COMPLETED.

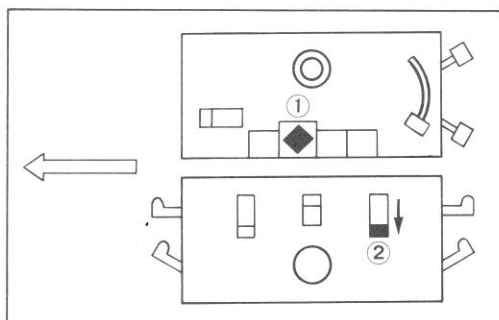

- 11 Carriages are at right.
Re-set carriages.
Main . . . ① (PLAIN \blacklozenge)
Rib ② (PLAIN)
Continue ribbing.

CIRCULAR KNITTING

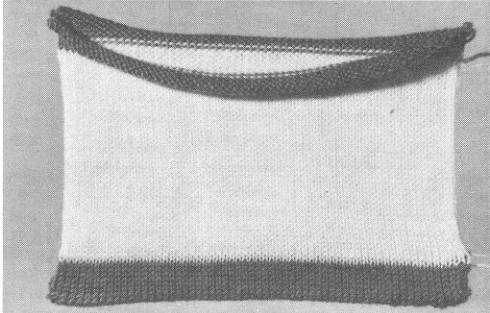

* Before making a garment, adjust tension dials to be even stitches on both beds.

* Use two large weights when knitting 50 stitches.

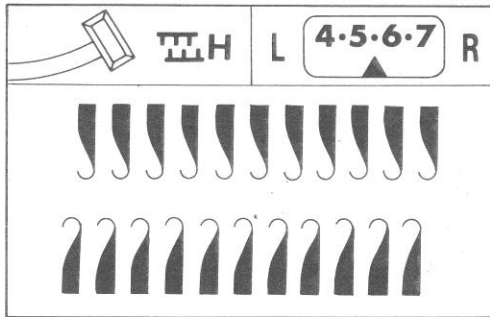

1 Half pitch lever H
Racking indicator . . . 5.6

2 Set needles as shown.

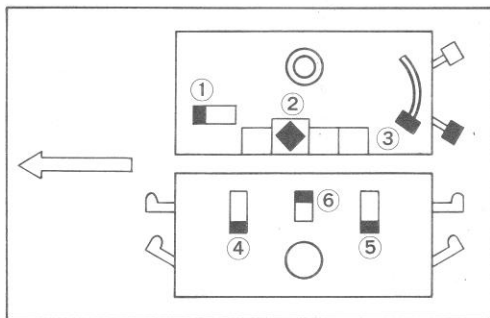

3 Set carriages.

Main . . . ①, ② (PLAIN \blacklozenge), ③
Rib . . . ④ ⑤ (PLAIN) ⑥ (EMPTY)

Carriages are at right.

4 Set tension dials.

(e.g. medium 4ply . . . $\frac{5}{5.2}$)

5 Thread waste yarn into feeder 0.

6 Slide carriages to left.

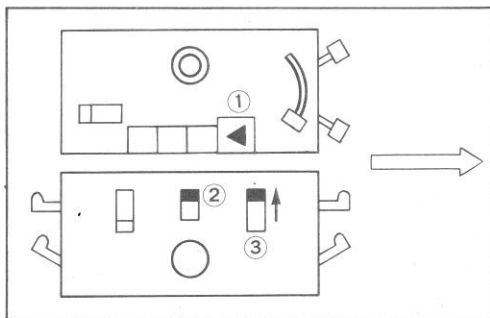

7 Hang cast on comb and weights so as to be balanced.

8 Re-set carriages.

Main . . . ① (EMPTY \blacktriangleleft)
Rib . . . ② ③ (EMPTY)

9 Work several rows of waste knitting.
Two strokes make one row of circular knitting.

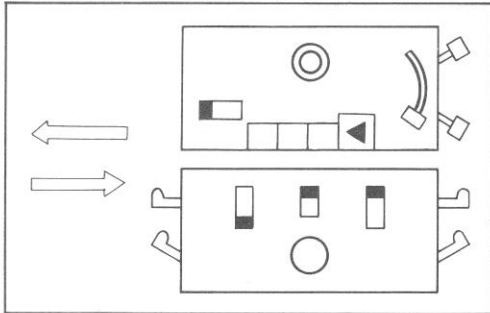

- 10 Carriages are at right.
Knit two rows with nylon cord.
Unthread nylon cord.

* If the end stitches come up while knitting, hang small weights.

* To get circular knitting with closed edge on both sides, do the waste knittings at the beginning and the last.

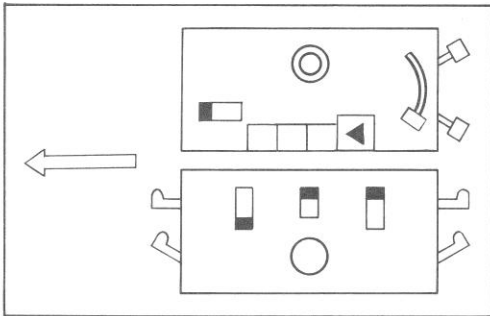

- 11 Thread main yarn through paraffin wax and then to the yarn feeder.

- 12 For crocheting edge, allow about three times as much yarn end as the width of knitting.
Knit required rows.

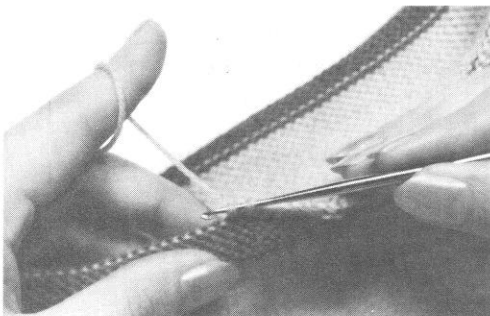

- 13 Allow about three times as much yarn end as the width of knitting to finish.
Remove main yarn.

- 14 Thread waste yarn.
Work several rows of waste knitting.

Remove the knitting from the machine.

Crochet both edges.

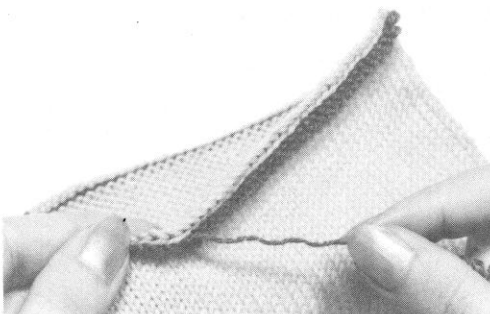

- 15 Remove waste knitting.

PATTERN RIB

SINGLE FISHERMAN'S RIB

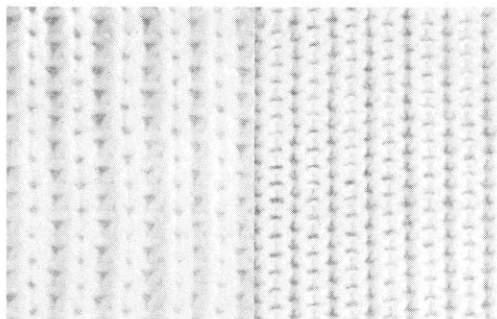

1 Cast on.

Follow steps 1–10 of “1x1 rib cast on” on p.10–11.

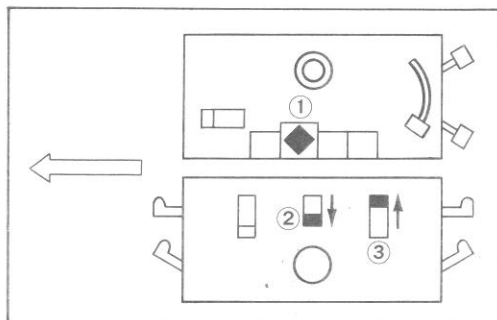

11 Re-set carriages.

Main ... ① (PLAIN ◆)

Rib ... ② ③ (TUCK)

12 Set tension dials one number tighter on rib carriage.
(e.g. medium 4ply ... $\frac{3}{2}$)

13 Continue ribbing.

* Hang small weights if end stitches come up.

DOUBLE FISHERMAN'S RIB

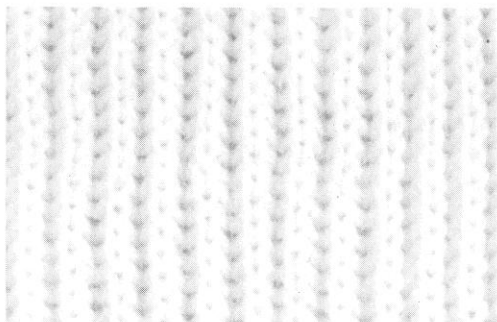

1 Cast on.

Follow steps 1–10 of “1x1 rib cast on” on p.10–11.

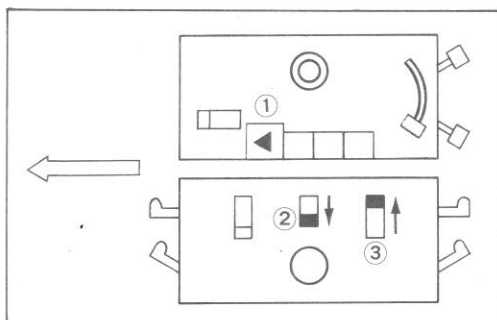

11 Re-set carriages.

Main ... ① (TUCK ◀)

Rib ... ② ③ (TUCK)

12 Set tension dials.
(e.g. medium 4ply ... $\frac{3}{3}$)

13 Continue ribbing.

RIPPLING

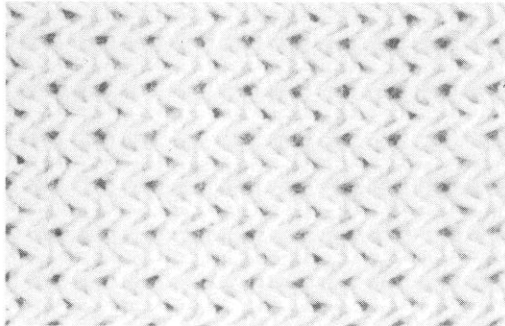

- 1 Cast on.
Follow steps 1–10 of “1x1 rib cast on” on p.10–11.

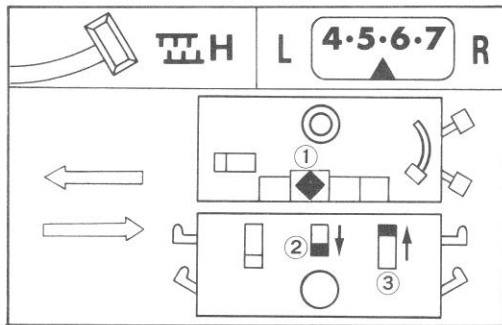

- 11 Re-set carriages.

Main ... ① (PLAIN \blacklozenge)
Rib ② ③ (TUCK)

- 12 Set tension dials.
(medium 4 ply ... $\frac{3}{3}$)

- 13 Re-set the lever.

Half pitch lever H
Racking indicator ... $\boxed{5 \cdot 6}$

- 14 Knit 2 rows.
Carriages are at right.

- 15 Turn Racking handle one pitch to right.

Racking indicator ... $\boxed{6 \cdot 7}$

- 16 Knit 2 rows.

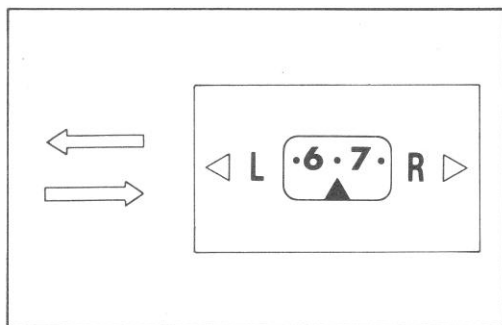

- 17 Turn Racking handle one pitch to left.

- 18 Repeat above steps 14–17.

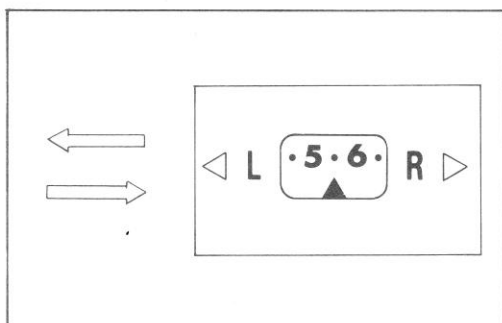

SWINGING RIB

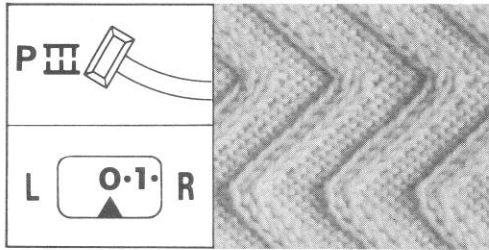

- 1 Half pitch lever P
Racking indicator . . . 0
- 2 Follow steps 2—10 of "1x1 rib cast on" on p.10—11.
- 11 Transfer all stitches on ribber to main bed using double-eyed transfer tool. (page 49)

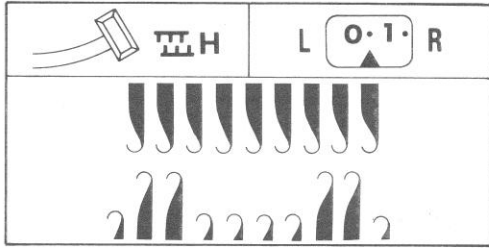

- 12 Re-set the lever.
Half pitch lever H
- 13 Set needle as shown.

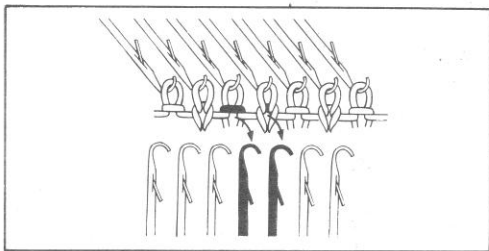

- 14 Pick up loops from main bed and place them on to selected needles on ribber.
- 15 Carriages are at right.
Re-set carriages (for plain knitting).

Main . . . ① (PLAIN ◆)
Rib . . . ② (PLAIN), ③ (0)

- 16 Set tension dials two numbers tighter on rib carriage.
(e.g. medium 4 ply . . . $\frac{5}{3}$)

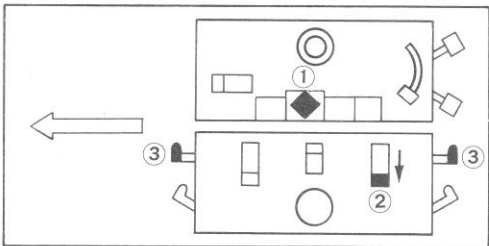

- 17 Knit one row.
Carriages are at left.
- 18 Turn racking handle one pitch to right.
- 19 Knit one row to right.
Turn racking handle one pitch to right.
- 20 Keep turning racking handle by one pitch per one row until racking indicator shows 10.

* Transfer stitches on ribber to main bed when they come out of knitted fabric. Bring the empty needle to A position.

* At the same time, keep pushing out needles of ribber on the other end to B position to complete pattern.

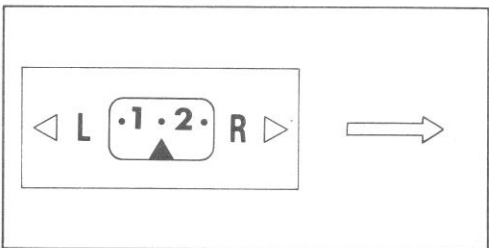

- 21 Continue knitting turning racking handle from 10 back to 0.
- 22 Repeat above steps 17 to 21.

* Keep pushing some needles on both ends of main knitter to E position in every row.

CABLE KNITTING

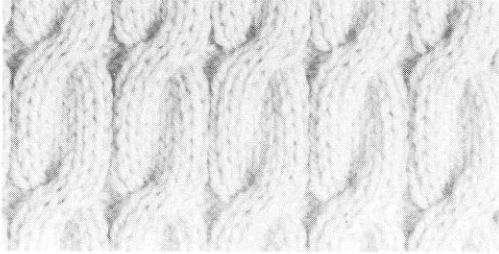

1 Cast on.

Follow steps 1–10 of “1x1 rib cast on” on p.10–11.

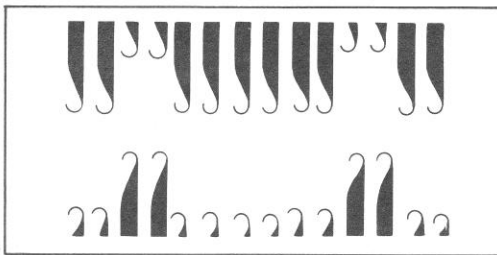

11 Transfer stitches with double-eyed transfer tool and re-set needles as shown.
(How to use double-eyed transfer tool, p. 49)

* Push back all empty needles to A position.

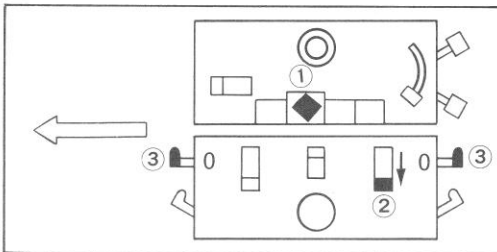

12 Re-set carriages. (for plain knitting)

Main ... ① (PLAIN ◆)

Rib ... ② (PLAIN), ③ (0)

13 Set tension dials.
(e.g. Medium 8ply ... $\frac{9}{9}$)

14 Knit required number of rows.
(e.g. 10 rows)

15 Transfer 6 stitches on to two transfer tools with 3 stitches in each.

16 Hook 3 stitches on right tool on to left 3 empty needles, and 3 stitches on left tool on to right needles.

17 Push those 6 needles out to E position.

18 Repeat steps 14 to 17.

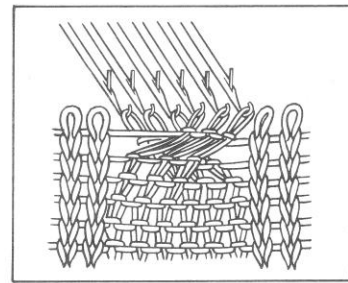
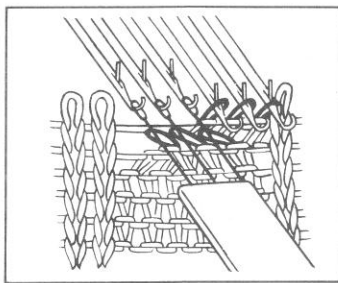
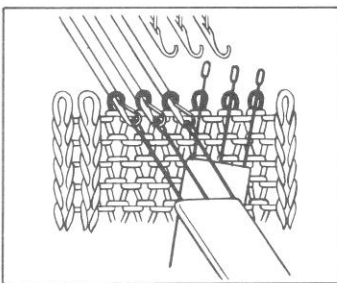

TUCK PATTERN RIB

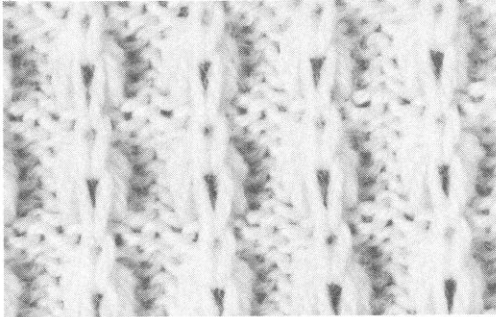

1 Cast on.

Follow steps 1–10 of “1x1 rib cast on” on p.10–11.

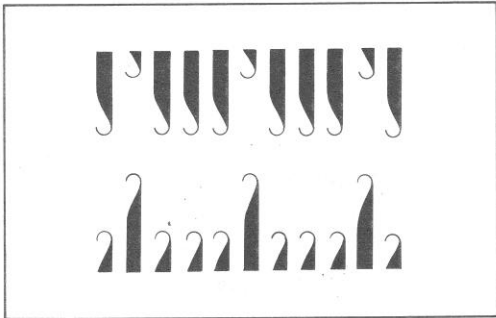

11 Transfer stitches and re-set needles as shown, using double-eyed transfer tool.

* Push back all empty needles to A position.

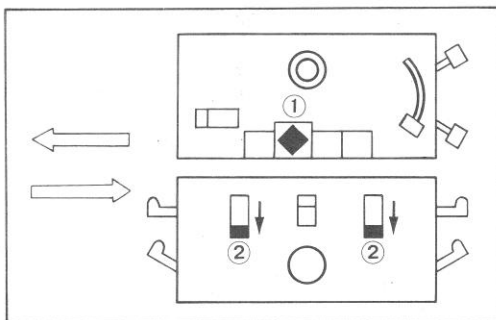

12 Re-set carriages (for plain knitting).

Main . . . ① (PLAIN ◆)
Rib . . . ② (PLAIN)

13 Set tension dials two numbers tighter on rib carriage.
(e.g. medium 4ply . . . $\frac{5}{3}$)

14 Knit 2 rows.

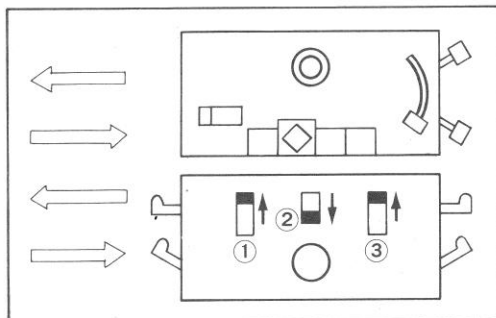

15 Re-set rib carriage . . ① ② ③ (TUCK)

16 Knit 4 rows.

17 Repeat above steps 12–16.

CHECKERED FISHERMAN'S RIB

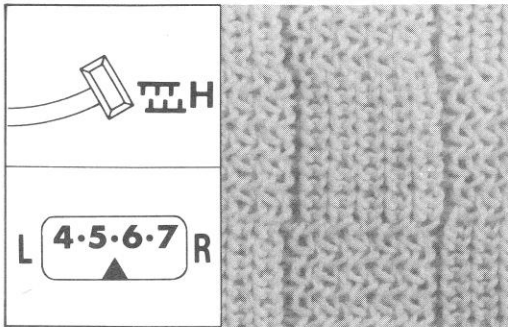

- 1 Cast on.
Follow steps 1—10 of "1x1 rib cast on" on p.10—11.
- 11 Re-set the lever.
Half pitch lever H
Racking indicator . . . 5:6
- 12 Set needles as below.
Transfer the left edge stitch on main bed on to the edge needle on ribber.

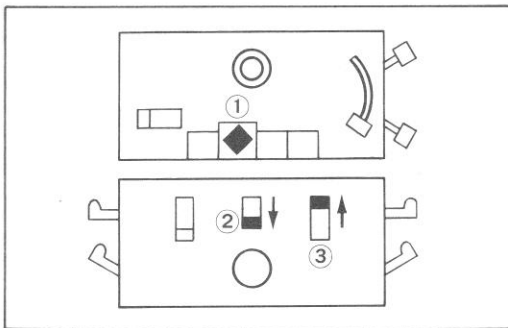
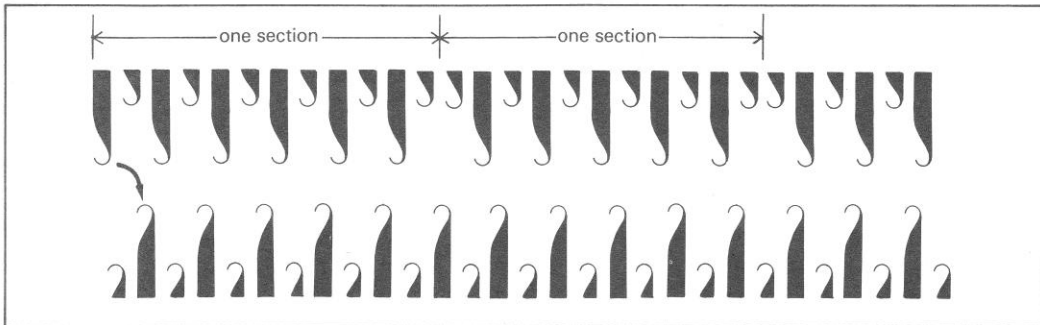

- 13 Carriages are at right.
Re-set carriages.
Main . . . ① (PLAIN \blacklozenge)
Rib . . . ② ③ (TUCK)
Set row counter 000.
- 14 Set tension dials one number tighter on rib carriage.
(e.g. medium 4ply . . . $\frac{4}{3}$)
- 15 Knit two rows.
* Bring the edge needles on main bed to E position in every row.
- 16 Turn Racking handle by one pitch to left.
- 17 Knit two rows.
- 18 Turn Racking handle by one pitch to right.
- 19 Repeat above steps 15 to 18 until row counter shows 20.
- 20 Knit two rows.
- 21 Turn Racking handle by one pitch to right.
- 22 Knit two rows.
- 23 Turn Racking handle by one pitch to left.
- 24 Repeat above steps 20 to 23 until row counter shows 40.
Steps 15 to 24 make one pattern.

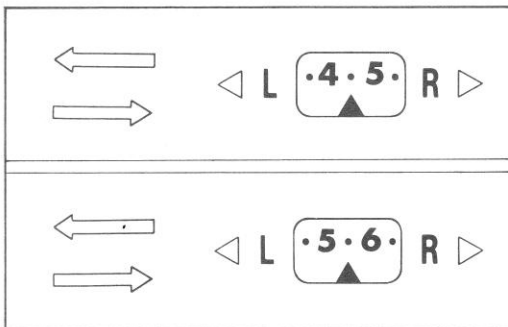

PUNCH CARD RIB

HONEYCOMB PATTERN

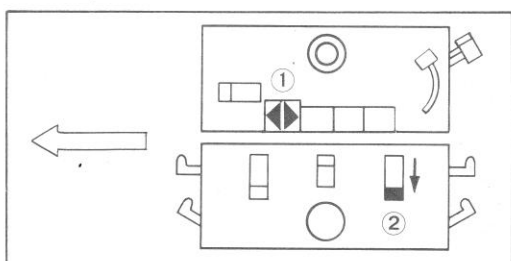
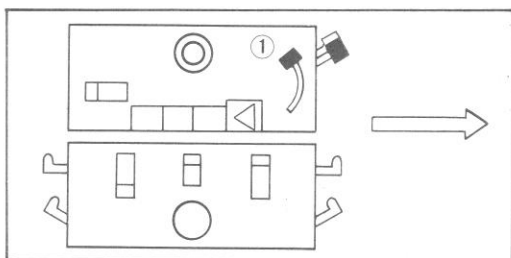
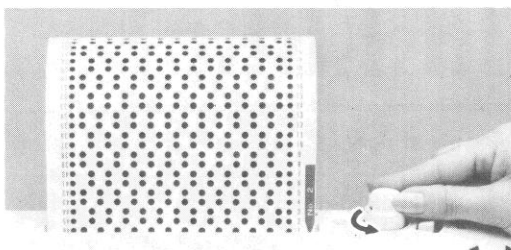
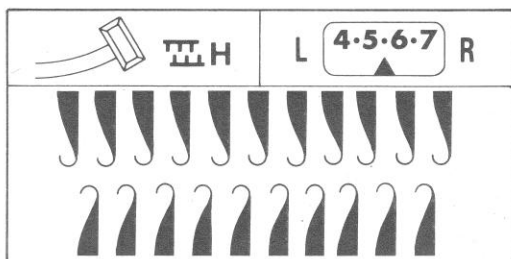
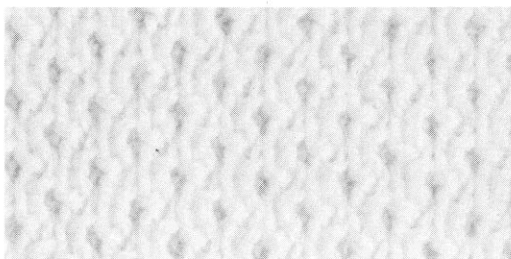

- 1 Cast on.
Follow steps 1—9 of “close rib cast on” on p.17.

- 10 Knit two rows changing both tension dials.
(e.g. medium 4ply . . . $\frac{4}{1}, \frac{4}{4}$)
Carriages are at left.

- 11 Set No. 2 punch card.
You can also use No. 3 punch card.

- 12 Re-set main carriage . . . ① (C)
Set card stop lever at ■.
Move carriages to right.
Needles are selected.

- 13 Re-set carriages.
Main . . . ① (TUCK ◀▶)
Rib . . . ② (PLAIN)
Set card stop lever at ▼.

- 14 Re-set tension dials.
(e.g. medium 4ply . . . $\frac{5}{5}$)

- 15 Continue ribbing.

PIN TUCK KNITTING

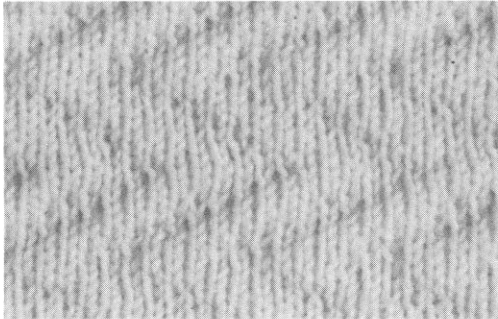

1 Cast on.

Follow steps 1—9 of “close rib cast on” on p.17.

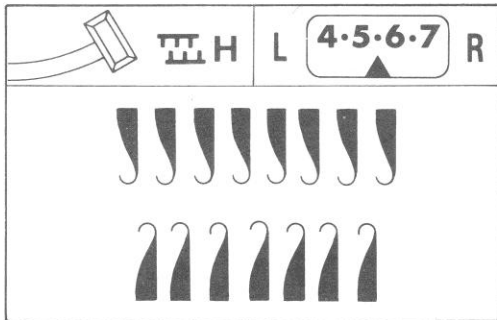

10 Knit two rows changing both tension dials.
(e.g. medium 4ply . . . $\frac{4}{1}, \frac{4}{4}$)

Carriages are at left.

11 Set No. 4 punch card.
You can also use No. 15 punch card.

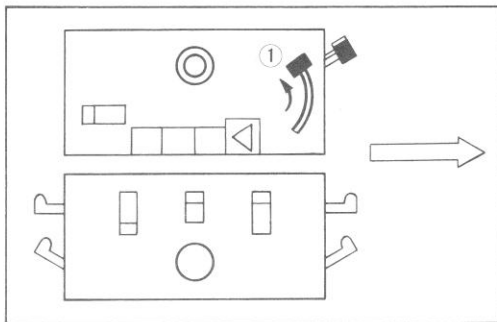

12 re-set main carriage . . . ① (C)

Set card stop lever at ■ .

Move carriages to right.
Needles are selected.

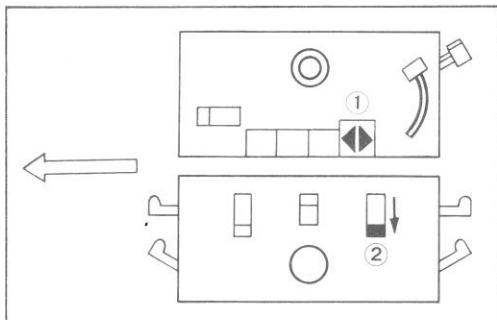

13 Re-set carriages.

Main . . . ① (EMPTY ◀▶)

Rib . . . ② (PLAIN)

Set card stop lever at ▼ .

14 Re-set tension dials.
(e.g. medium 4ply . . . $\frac{5}{5}$)

15 Continue ribbing.

CASTING OFF

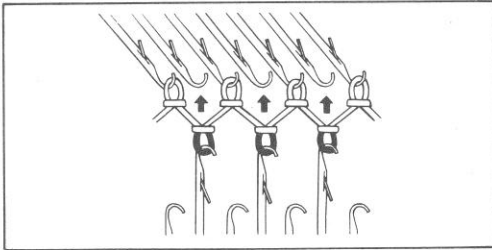

1 Transfer all stitches on ribber to main bed using double eyed transfer tool. (p. 49)

2 Set needles.

Main . . . B position
Rib A position.

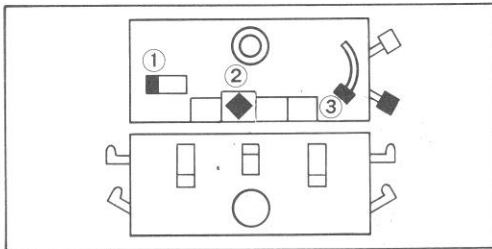

3 Set Main carriage . . . ① , ② (PLAIN ◆), ③

Set tension dial on main carriage in larger number.
(e.g. 6–9)

4 Knit one row.

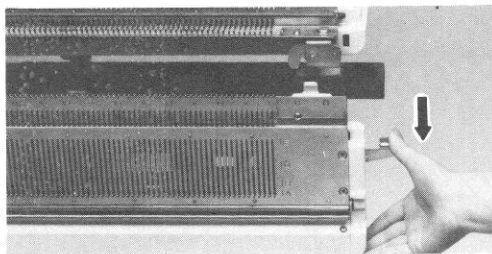

5 Detach coupling.

6 Lower ribber by pushing down drop levers on both sides.

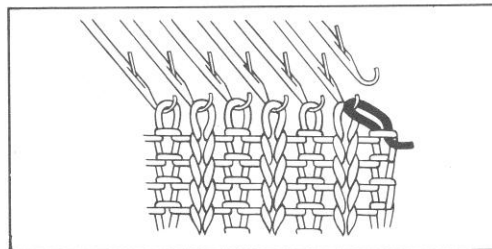

7 At carriage side, transfer the edge stitch to its adjacent needle and push the needle to E position.

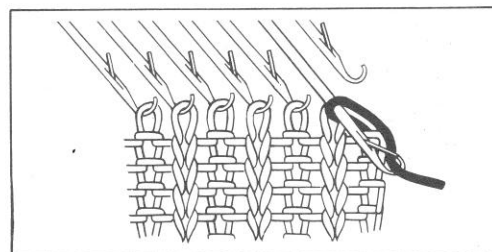

8 The needle latch must be open.
Pull the yarn from carriages and place it on to the open needle hook.

Pull the needle back to B position.
Bring back the empty needle to A position.

SIMULKNIT

CAST ON

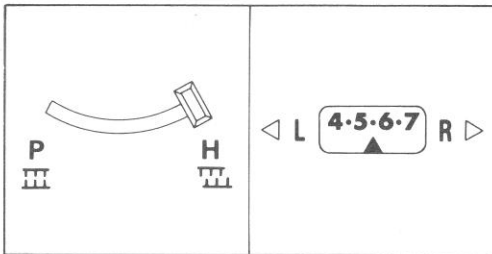

- 1 Half pitch lever H
Racking indicator . . . 5.6

Carriages are at right.

Set Upper tension dial between "▲" and "—".
Use paraffin wax at upper Tension unit.

- 2 Set needles as shown.
Both END needles are on Ribber.

* For making reversible garment, cast on in the same manner. (See p 45)

- 3 Set carriages.

Main . . . ①, ② (PLAIN ◆), ③
Rib . . . ④ ⑤(0), ⑥ (PLAIN), ⑦

Set simulknit lever on coupling at O. Set both Tension dials referring to the chart below.

- 4 Thread col. 1 (main yarn) through the left side of upper tension unit and into feeder 0.

- 5 Knit one row to left.

- 6 Insert cast on comb and wire between both beds, and hang weights so as to be balanced.

* Use small weights to prevent dropped stitches.

* Use Yarn spray (Optional), this makes Simulknit quite smooth.

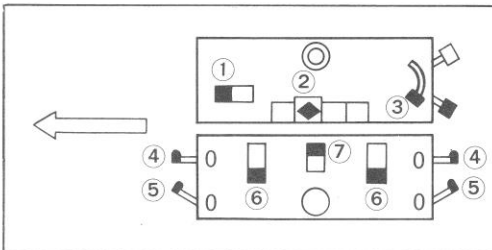
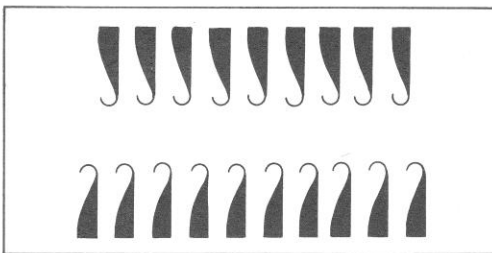

		1	2	3
TYPE OF YARN				
ACTUAL SIZE				
NAMES		2 ply	3 ply	medium 4 ply
CAST ON	1st threading	$\frac{0}{0}$	$\frac{0}{0}$	$\frac{1}{1}$
	2nd row	$\frac{1}{0}$	$\frac{2}{0}$	$\frac{4}{1}$
	3rd and 4th row	$\frac{1}{1}$	$\frac{2}{2}$	$\frac{4}{4}$
SIMULKNIT		$\frac{2}{3}$	$\frac{4}{5}$	$\frac{5}{6}$

(Names of type of yarn will vary in each country.)

* It is recommended to use these yarns shown on left for Simulknit.

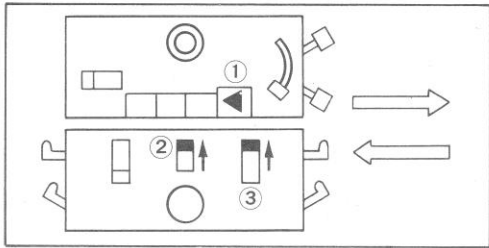

7 Set carriages

Main ... ① (EMPTY ◀)
 Rib ... ② ③ (EMPTY)

8 Knit 2 rows changing both tensions referring to chart on previous page.

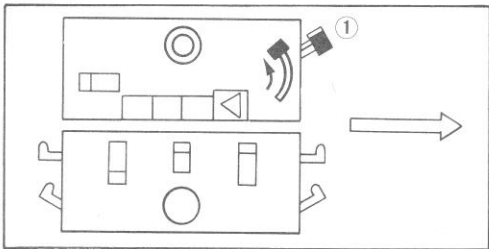

9 Carriages are at left.
 Set punch card.

10 Set main carriage ... ① (C)
 EMPTY is still set.
 Set card stop lever at ■.

11 Knit one row to right and the needles on main bed will be selected.

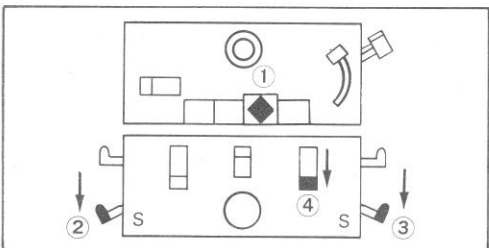

12 Re-set carriages

Main ... ① (COLOUR ◆)
 Rib ... ② ③ (S), ④
 Coupling ... Simulknit lever at S.

Set card stop lever at ▼.

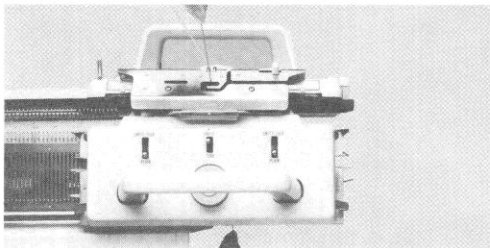

13 Thread S yarn (Col. 2) through right side of upper tension unit and into feeder S in the same way as threading col. 1, or use Threader.

* Do not knit a knot.

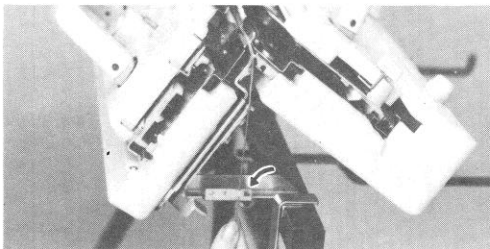

14 Hook the end of S yarn to yarn holder slot.
 Knit one row.

Remove the yarn end from yarn holder slot.
 Continue knitting.
 Bring the edge needle of main bed on carriage side to D position every row.

* It is not recommended to do Motif Magic with simulknit.

* Re-hang side weights every 60 rows or when one punch card finished.

CASTING OFF

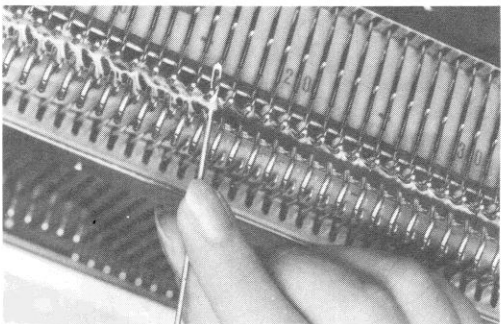
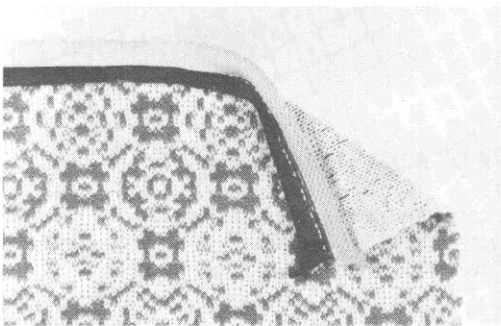
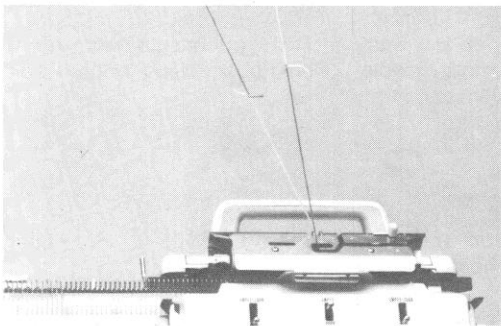
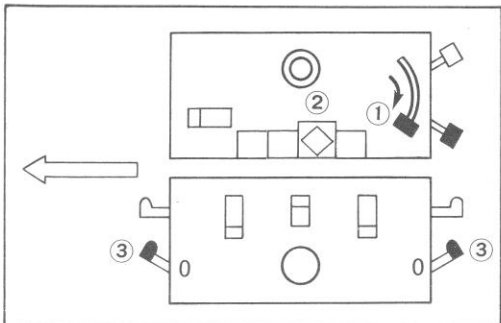

Method I

Neat finish with waste knitting, suitable for shoulder and other seaming.

- 1 Carriages are at right.
Set carriages.

Main . . . ① (0)

② (COLOUR ◆) is still set.

Rib . . . ③ (0)

Both tension dials are set at one number looser.

If there are needles in D position on main bed, bring them to B position with a transfer tool.

- 2 Knit one row.
Cut both yarns leaving ends approx. 30–50 cm long above feeder.
Remove col. 1 and S yarn from tension unit.
- 3 Thread two waste yarns through each right and left side of tension unit.

* Colours of waste yarns should be easily distinguished from those of col. 1 and S yarn to make seaming much easier.

- 4 Tie one of waste yarns with col. 1 and the other with S yarn.

Pull down both yarns under the carriages.

Move carriages holding yarns at knots with left hand.

Do some waste knitting.

Remove the knitting from the machine.

For seaming, see page 44.

Method II

Transfer all the stitches on ribber to main bed.

Cast off stitches with method of "Big Loops" or "Bind-off" in main knitter manual.

TECHNIQUES FOR MAKING GARMENTS

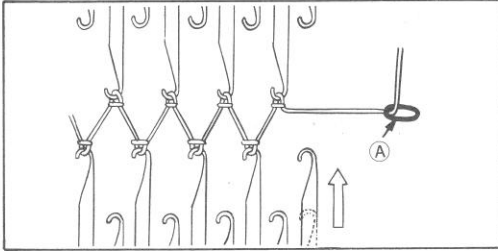

SIMPLE INCREASE OF ONE STITCH

On the carriage side, bring an empty needle (next to the last working needle) to B position.

Ⓐ . . . Yarn feeder

Continue knitting.

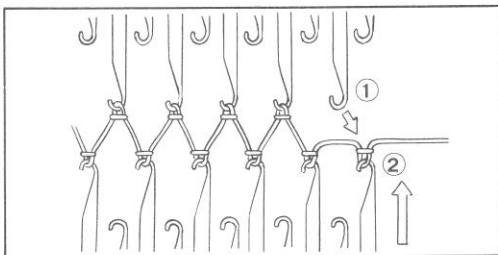

FASHION INCREASE OF ONE STITCH

1 Carriages are at either side.

Transfer the end stitch ① on main knitter on to the empty needle ② on ribber, using double-eyed transfer tool.

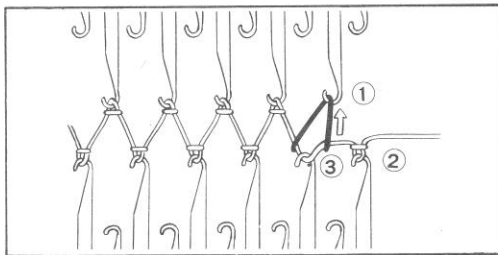

2 Pick up the loop under the stitch ③ on ribber, then hook it on to empty needle ①.

Continue knitting.

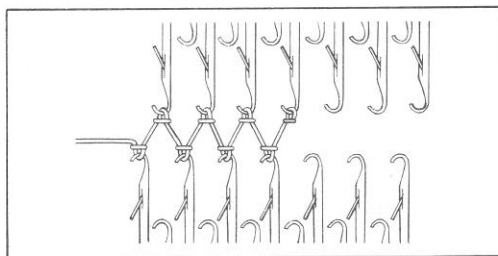

INCREASE OF SEVERAL STITCHES

1 With carriages at the opposite end where needles are increased, bring required number of needles to B position on both beds.

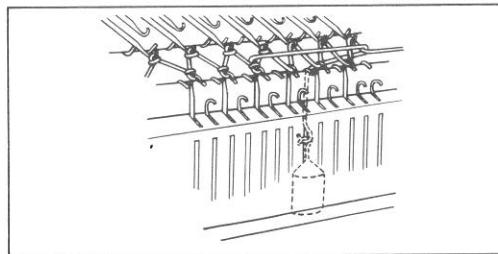

2 Knit one row, and yarn will be laid over the needles.
Hang the weight hook and small weight at the edge.

Continue knitting.

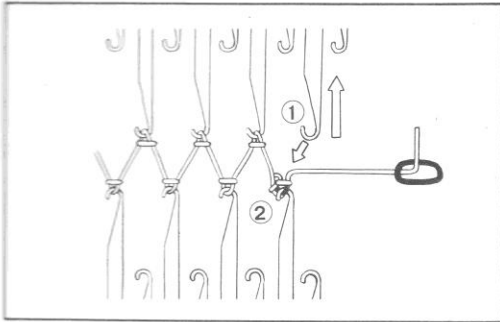

SIMPLE DECREASE OF ONE STITCH

Transfer the end stitch ① on main knitter on to the end needle ② on ribber.

Push back the needle ① to A position.

Continue knitting.

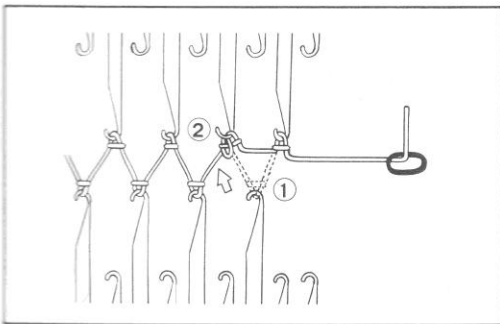

FASHION DECREASE OF ONE STITCH

1 Transfer the end stitch ① on ribber on to the second needle ② on main knitter.

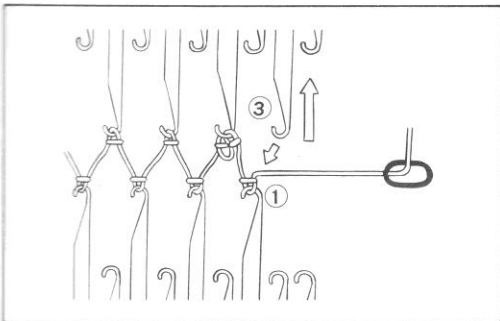

2 Transfer the end stitch ③ on main knitter on to the empty needle ① on ribber.

Push back the needle ③ to A position.

Continue knitting.

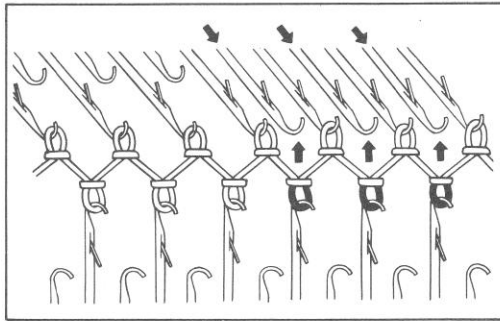

DECREASE OF SEVERAL STITCHES

Method I

- 1 Work at carriage side.
Transfer all the stitches to be decreased on to main bed.

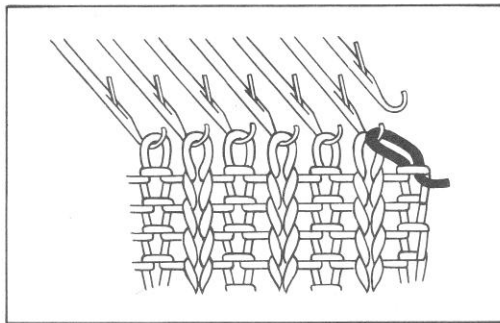

- 2 Transfer the edge stitch to its adjacent needle and push the needle to E position.

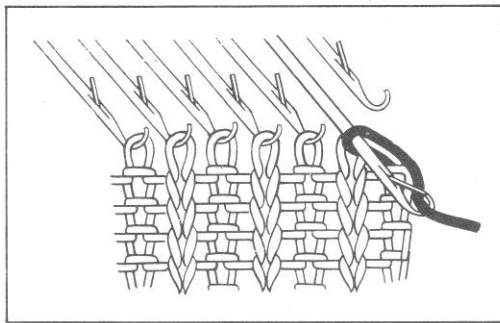

- 3 The needle latch must be open.
Pull the yarn from carriages and place it on to the open needle hook.

- 4 Pull the needle back to B position.
Bring back the empty needle to A position.

- 5 Decrease required number of stitches following above steps.

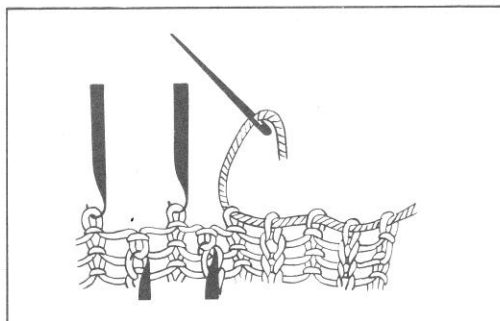

Method II

- 1 Work at the opposite side to carriage.
Pick up stitches to be decreased with waste yarn piece. (use tapestry needle)
- 2 The stitch will be picked up later when finishing a garment.

PARTIAL KNITTING

BUST DARTS

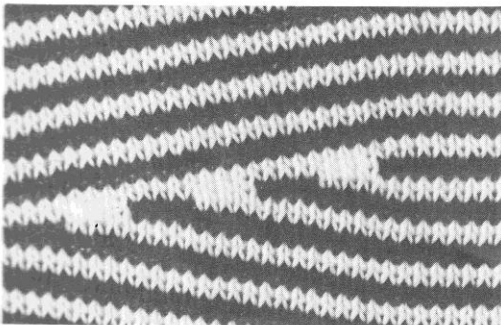
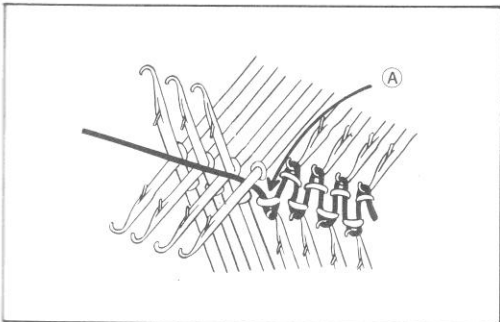
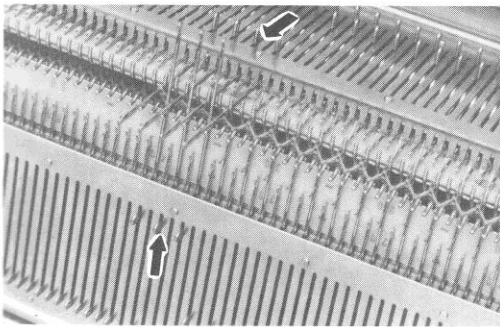
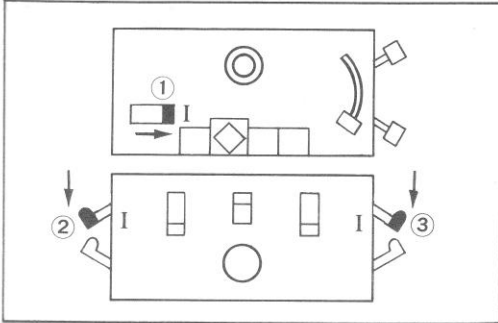

This is used for shaping darts, neck lines, shoulders, heels of socks, etc.

Hold the needles in E position and knit a part of row.

- 1 Set carriages.

Main ... ① (I)

Rib ② ③ (I)

- 2 Following your pattern, bring required number of needles on both beds to E position on the opposite side to the carriage.

The end needle to be knitted should be always on Ribber.

- 3 Knit one row.

- 4 Place the yarn under the first needle in E position, then pass it over the rest.

- 5 Knit the second row.

Repeat above steps from 2 to 5.

* To change yarn while doing partial knitting, cut S yarn leaving the end 30–50cm long above feeder. Remove it from tension unit and thread another S yarn. Tie it with former S yarn. Pull down the knot between the far end of knitting needle and the first needle of E position. (A)

- 6 When the pattern is completed, release partial levers ① ② ③ to 0.

- 7 Continue knitting.

* Knit in the same way when Tuck or Empty buttons are used.

* When doing partial knitting on both sides, hang weight hooks and small weights on both edge needles in B position.

Re-hook every 5 or 6 rows.

REVERSED DARTS (Side darts)

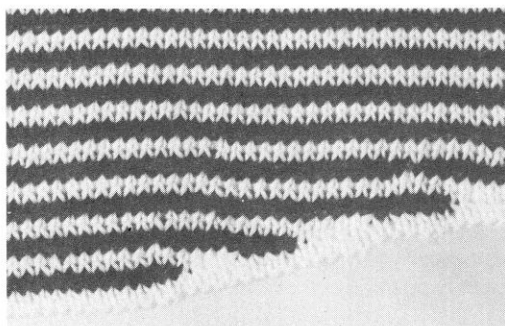
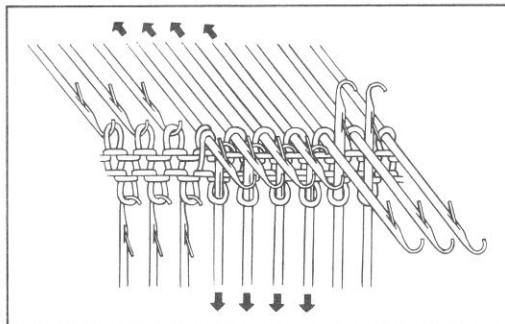
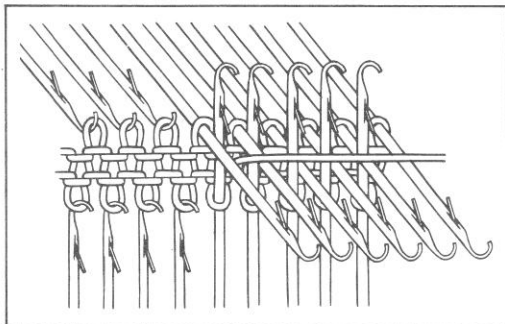
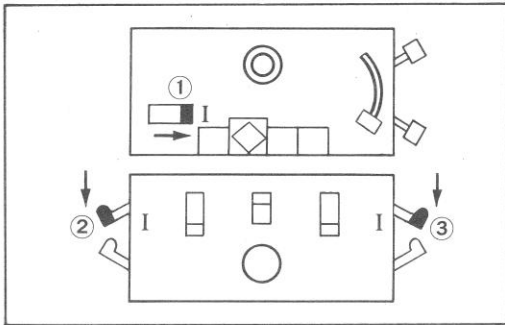

This is used for the bottom of skirts or socks, etc.

IN PLAIN KNITTING

- 1 Set carriages.

Main ... ① (I)

Rib ② ③ (I)

Assume some of needles are already in E position in this case.

- 2 On the carriage side, push back required number of needles to be knitted wider on both beds, from E to D position.

- 3 Knit one row.

- 4 Place the yarn under the first needle in E position, then pass it over the rest. (see previous page)

- 5 Knit the second row.

Repeat steps 2 to 5.

WHEN DIAL AND LEVERS ARE SET AT TUCK OR EMPTY.

- 1 Set carriage same as above. Other dial and levers are set as for required pattern.

- 2 On the carriage side, push required number of needles to be knitted wider from E to B position, using transfer tool.

- 3 Knit one row.

- 4 Pass the yarn end under the first needle in E position, then pass it over the rest.

- 5 Knit the second row.

Repeat steps 2 to 5.

* When doing partial knitting on both sides of knitting, hang weight hooks and small weights at edge needles in B position.

Re-hook every 5 or 6 rows.

WHEN RACKING HANDLE IS USED

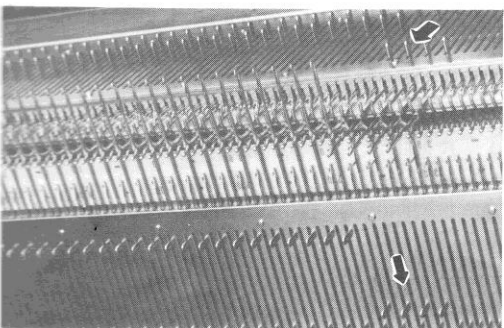
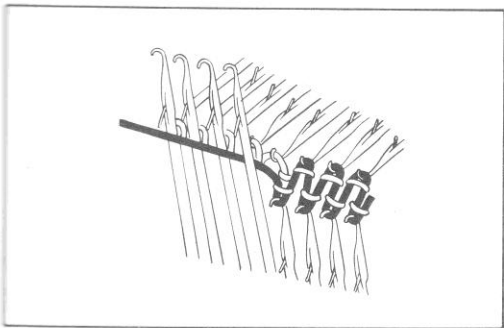
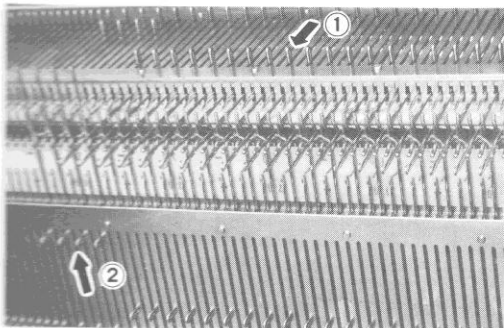
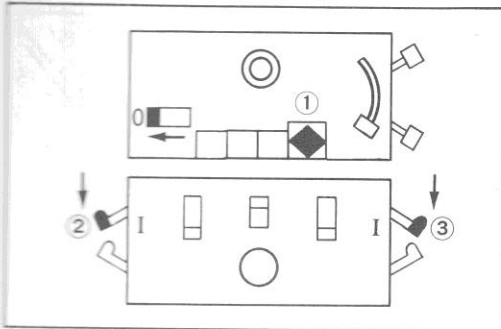

BUST DARTS

- 1 Set carriages.

Main ... ① (EMPTY ◀)

Rig ② ③ (I)

Other buttons and levers are set for required stitch patterns.

- 2 Move racking handle according to the stitch pattern.

- 3 Work at the opposite side to carriage.

Main knitter..... Push all the required needles to be knitted to E position ① .

Ribber..... Push required number of needles NOT to be knitted to E position ② .

- 4 Knit one row to left.

- 5 Place yarn under the first needle in E position, then pass it over the rest.

- 6 Again, push all the needles to be knitted on main knitter to E position.

- 7 Knit one row to right.

Repeat steps 2 to 7.

SIDE DARTS

Assume some needles are already in E position.

Follow above steps except step 3.

Step 3 is as follows.

- 3 Main knitter..... Push required number of needles to be knitted to E position.

Ribber..... Using transfer tool, push back required number of needles to be knitted to B position.

BUTTONHOLE

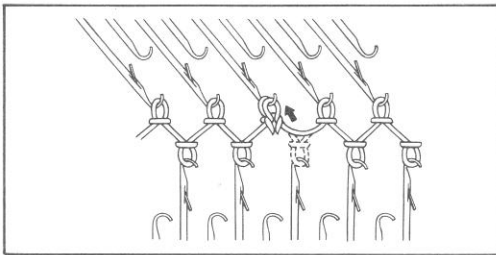
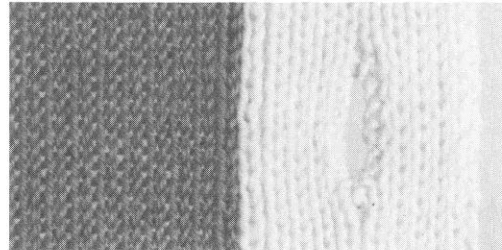
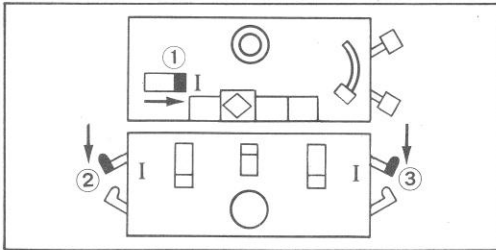

- 1 Carriages are at right.
Set carriages.

Main ... ① (I)
Rib ... ② ③ (I)

- 2 Transfer 1 stitch from ribber to main bed at the buttonhole position.

Push back the empty needle to A position.

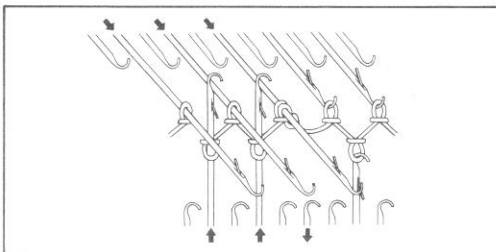

- 3 Bring all needles on left of buttonhole to E position.

- 4 Knit an odd number of rows for the buttonhole. When right side of the buttonhole is completed, cut the yarn leaving its end approx. 30cm long above.

- 5 Bring the carriage to left.

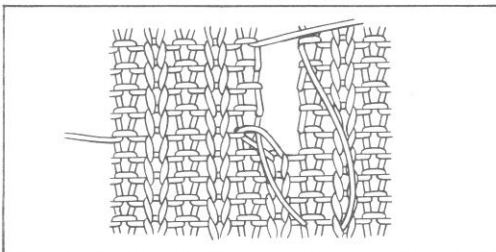

- 6 To knit the other side of buttonhole, push back needles on left to D position. Bring all needles on-right to E position.

- 7 Thread the yarn and knit the same number of rows as the first knitted side.

- 8 Cut the yarn leaving its end approx. 30cm long above for finishing buttonhole later.

- 9 Pick up the loop of the row below the top on main bed and place it on the empty needle on ribber.

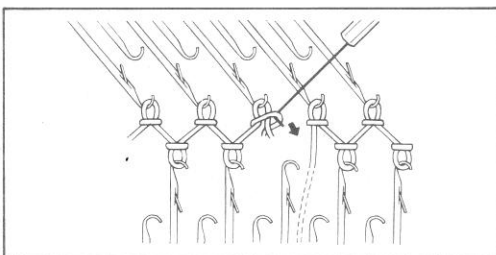

- 10 Set both carriages for plain knitting. Continue knitting.

- 11 Work buttonhole stitch with the yarn left in step 8.

EYELET BUTTONHOLE

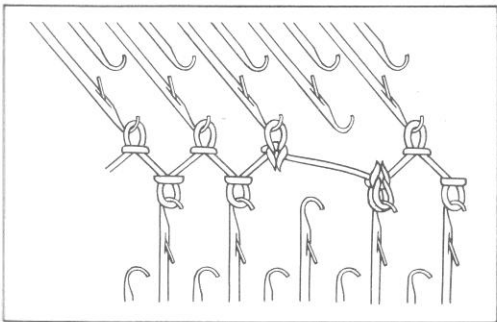
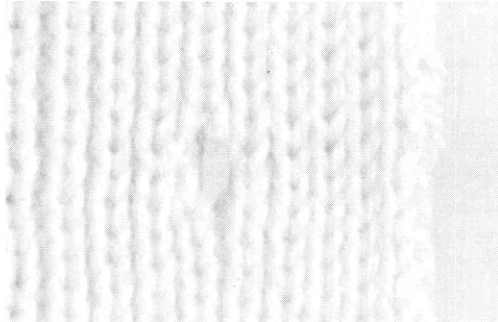
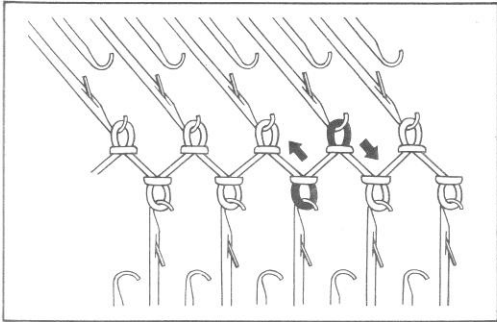

- 1 At the buttonhole position, transfer 2 stitches as in diagram.
- 2 Leave the empty needles in B position. Continue knitting.

SEAMING

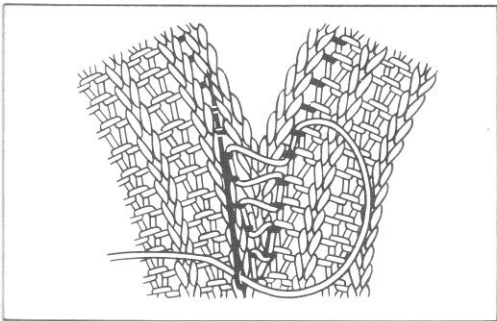

1X1 RIB

Pick up two loops with right side facing you.

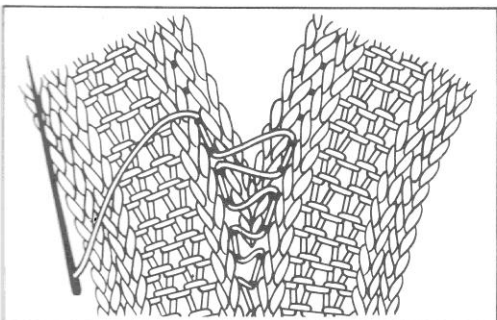

2X2 RIB

TECHNIQUES FOR MAKING GARMENTS BY SIMULKNIT

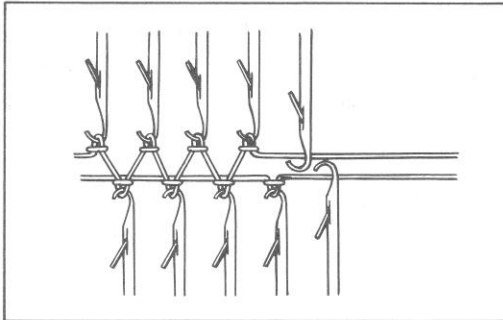

INCREASE OF ONE STITCH

- 1 On carriage side of both beds, push outside empty needles to D position.
Bring the yarns under these two needles.
- 2 Knit one row.

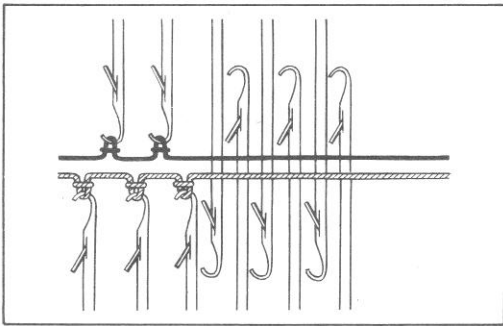

INCREASE OF SEVERAL STITCHES

- 1 On the carriage side, bring required number of needles on both beds to D position.
- 2 Bring the two yarns over the needles on both beds.

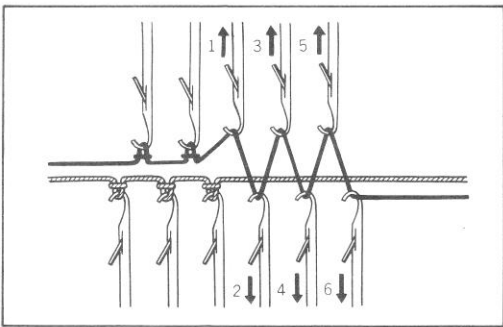

- 3 From the next needle to the last knitted needle, hook the main yarn on to each needle on both beds by pushing back, and bring to B position.

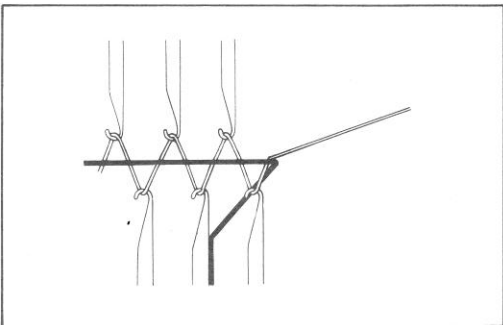

- 4 Hook small weights.
Continue knitting.

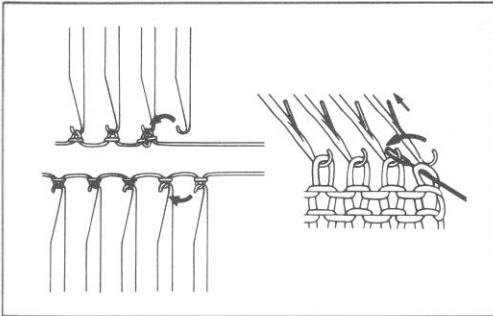

SIMPLE DECREASE OF ONE STITCH

Transfer the end stitch on to the adjacent needle on main and ribber beds.

Push back empty end needles to A position.

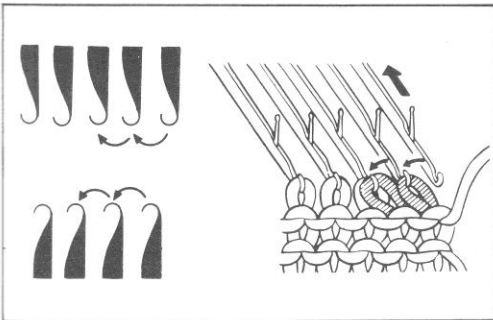

FASHION DECREASE OF ONE STITCH

With double transfer tool, transfer 2 end stitches to 2nd and 3rd needles as shown.

Push back empty end needles to A position.

DECREASE OF SEVERAL STITCHES

Work at carriage side.

Cast off each stitch on main and rib beds separately.

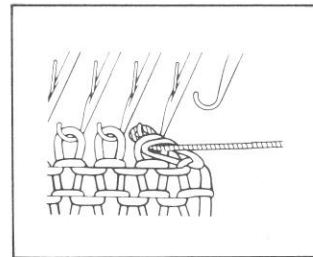
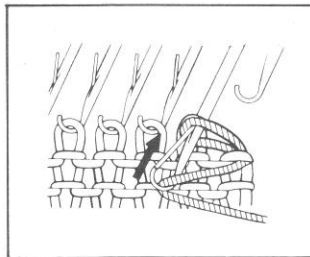
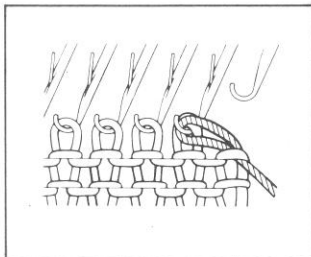

PARTIAL KNITTING

BUST DARTS

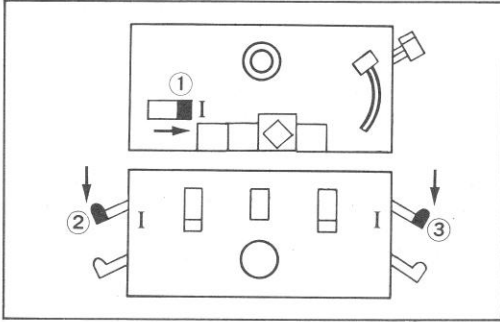

1 Set carriages.

Main ... ① (I)
Rib ② ③ (I)

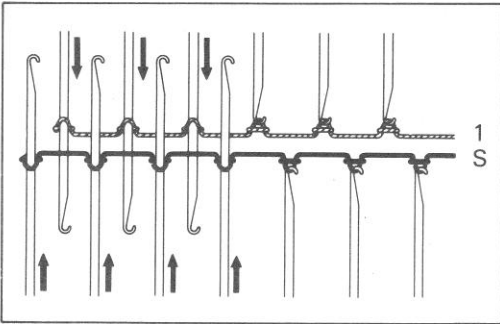

2 On opposite side to the carriages bring required needles not to be knitted to E position.

* END needle of E position is always on Ribber.

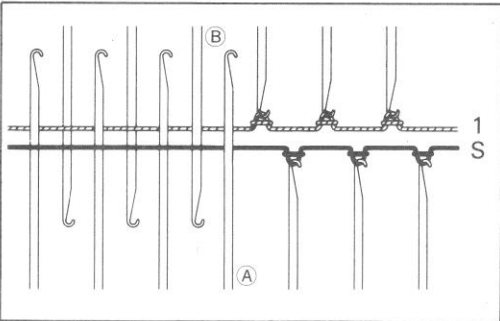

3 Knit one row.

Col. 1 and S yarns are over each E position needles.

Bring S yarn under needle ①.
Push needle ② backwards to bring col. 1 under the needle then push back to E position.

Be sure S yarn passes over the needle ③.

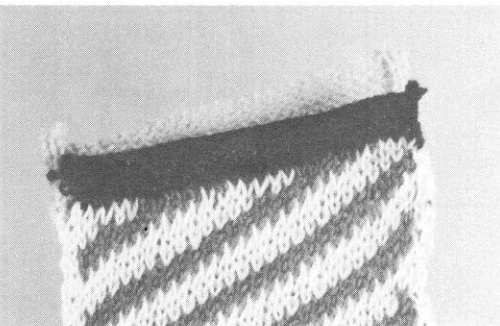

4 Knit one row, pulling up yarns by hand over carriages to adjust yarn tension.

Repeat 2 to 4.

When there are a group of needles in E position on carriage side, and if the needle next to edge needle of E position is selected, push it back to B position.

SIDE DARTS

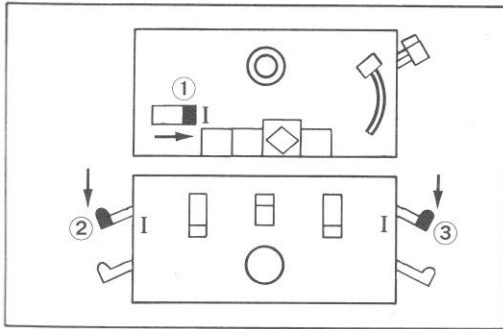

- 1 Set carriages.

Main... ① (I)
Rib ② ③ (I)

In this case some of needles are already in E position.

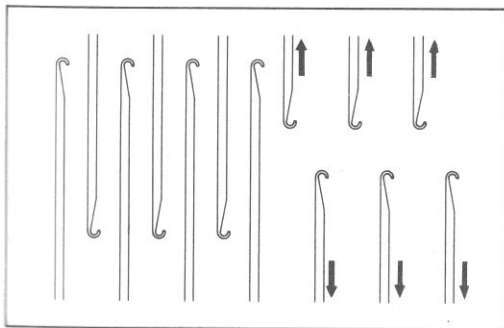

- 2 On the opposite side to carriages, push back required needles to be knitted with col. 1 to B and S yarn to D position according to the pattern on main bed, and all to D position on rib bed.

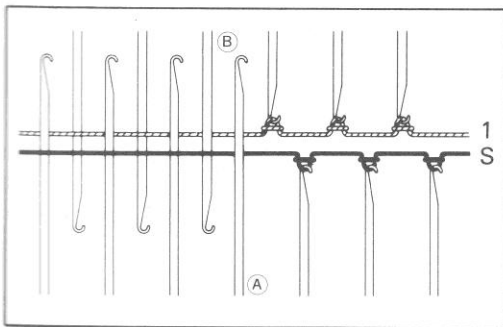

- 3 Knit one row.

Col. 1 and S yarns are over each E position needles.

Bring S yarn under needle ①.
Push needle ② backwards to bring col. 1 under the needle then push back to E position.

Be sure S yarn passes over the needle ②.

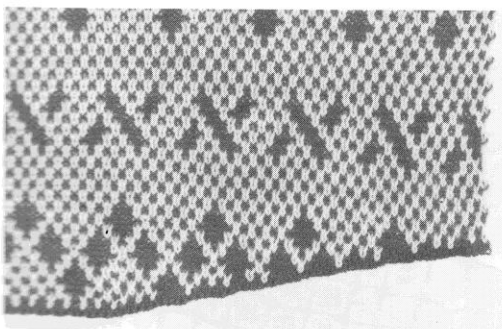

- 4 Knit 1 row, pulling up yarns by hand over carriages to adjust yarn tension.

Repeat 2 to 4.

SHOULDER SEAMING (GRAFTING)

— Finish pieces with waste knitting using 2 colours (page 31).

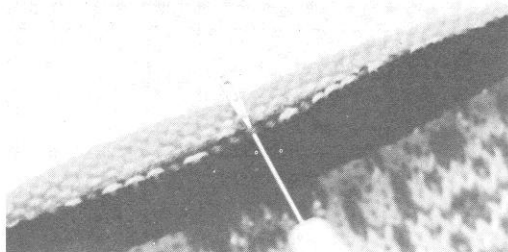

- 1 Hold the BACK of garment with right side facing you.

With single transfer tool, pick up each stitch of main side and rib side of shoulder on your left.

Transfer them on to a needle.
Do this for all the stitches.

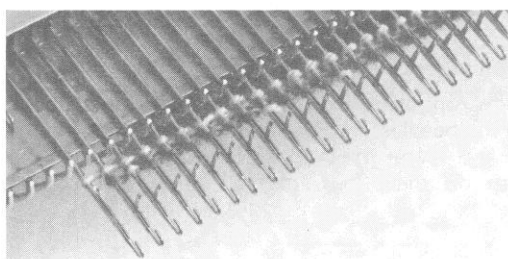

- 2 Bring needles forward and push back stitches behind latches.

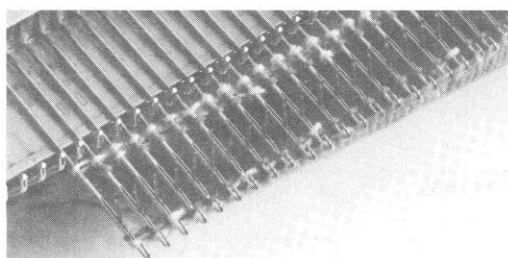

- 3 Hold left side of garment FRONT with wrong side facing you.

Pick up stitches as for BACK and hook them on to the needle which already has two loops.

Do this for all the stitches.

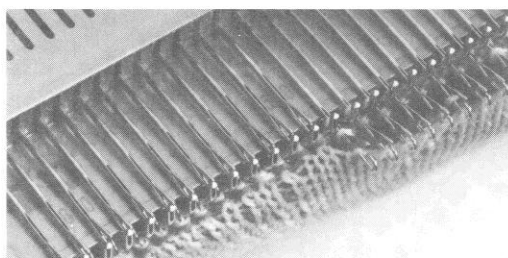

- 4 Bring the needles with stitches to B position.

The loops in hook are knitted with the other loops behind.

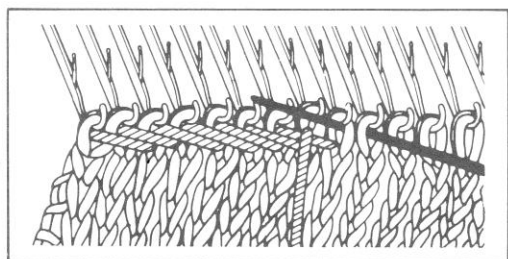

- 5 Thread yarn end into tapestry needle.
Graft the stitches as shown.

* For side seaming, see p.39.

TO MAKE REVERSIBLE GARMENTS

Knit and make up reversible garments in neat way as explained in Method 1 or in quick and easy way as explained in Method 2.

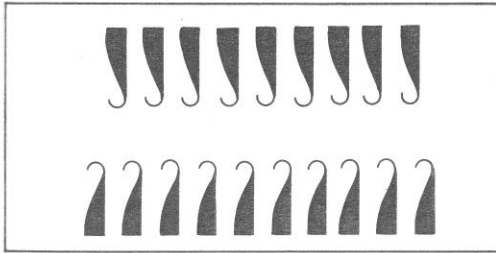

SEAMING ON PLAIN SIDES

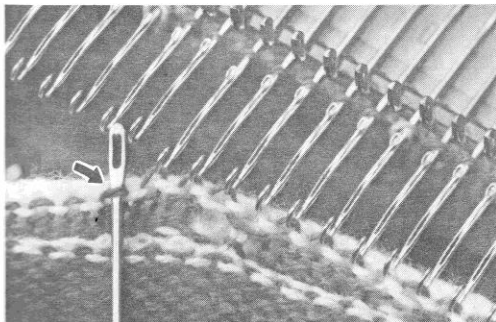
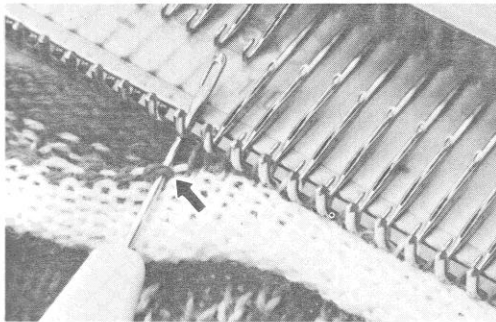
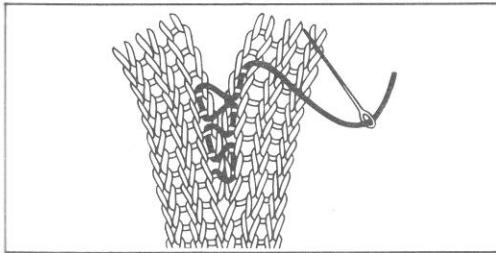

Method 1 (neat way)

1 CAST ON AND KNITTING

Set needles as shown.

End needles are on RIB bed.

2 SIDE SEAMING

Seam pattern side with pattern side and plain side with plain side.

SEAMING ON PATTERN SIDES

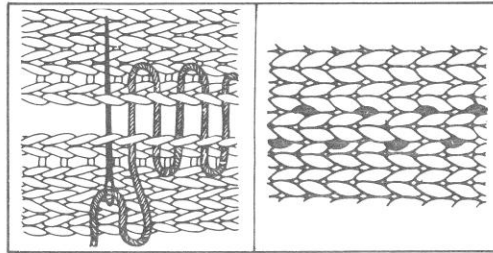

3 SHOULDER SEAMING

—Finish pieces with waste knitting using 2 colours.
Drop ribber (see p. 50)

① Hold BACK of garment with pattern side facing you.

Pick up pattern side stitches of shoulder on to needles.

Unravel the waste knitting of the side.

② Bring needles forward and push back stitches behind latches.

③ Hold FRONT of garment with plain side facing you.

Pick up pattern side stitches of shoulder on to needles.

Unravel the waste knitting of the side.

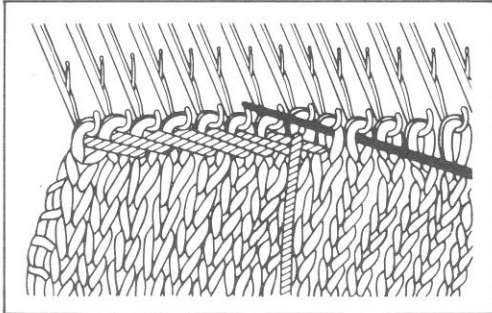

- ④ Graft stitches of two pieces with tapestry needle.
Remove the knitting from the machine.

- ⑤ Then graft stitches of plain side of garment as in diagrams.

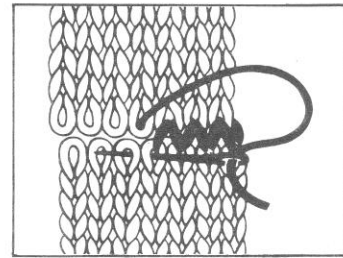
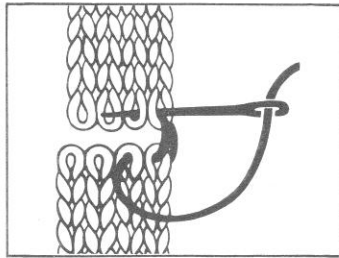
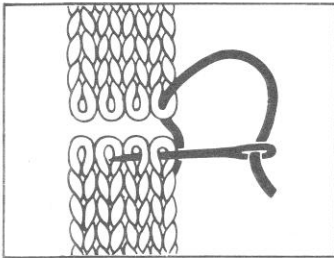

Method 2 (easy and quick way)

Knit extra stitches and rows for seaming.

Prepare tapes and sew on to seams of garment, the length of tape being equal to both pattern and plain sides. There are many kinds of tapes available such as synthetic suede, wool tape velvet or program ribbons. Narrow strips of sewing materials, at proper thickness are also suitable.

A

- 1 Sew with multiple zigzag stitches. Or use straight stitch and open the seam.

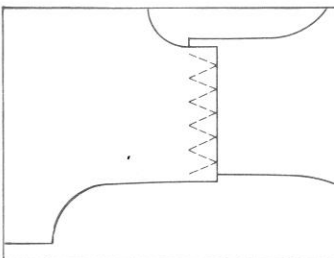

- 2 Place tapes over the seams and sew. Work with each side of material.

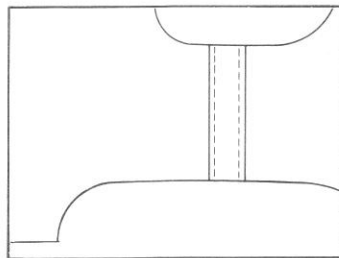

B

- 1 Knit bindings using main bed or double beds. Sew it on each side of material.

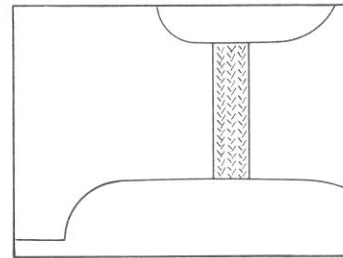

12 TECHNICAL HINTS

CARRIAGE JAMMING

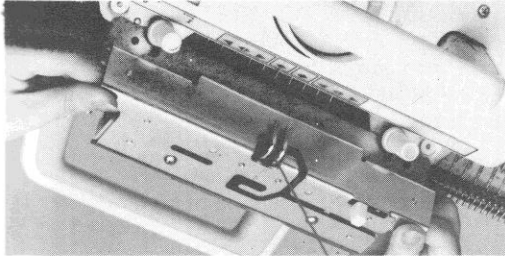

- 1 Do not move carriages by force.

Remove thumb screws.

Take out coupling by lifting directly upwards not to damage needles.

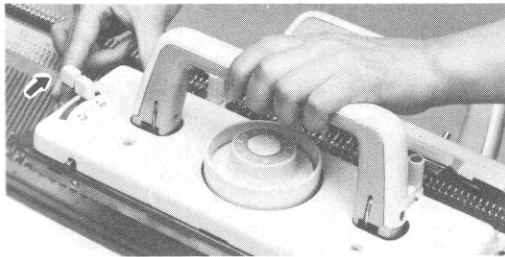

- 2 Pull forward Carriage-release lever of main carriage.

Remove the carriage from back rail and then front rail.

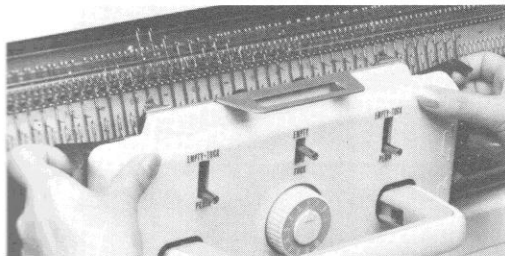

- 3 Pull both front holders of rib carriage.

Keep holding them, tilt the carriage towards you and slide it out of the working section.

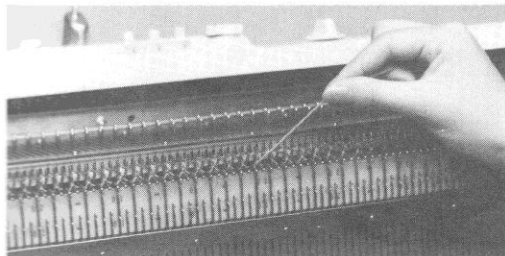

- 4 If there is any dropped stitch, see p. 49.
Using transfer tool, set all stitches down to B position.

Change needles if they are bent or broken.

Unravel stitches carefully up to beginning of row, to the side of rib carriage.

If necessary, unravel the required number of rows.
Re-set row counter.

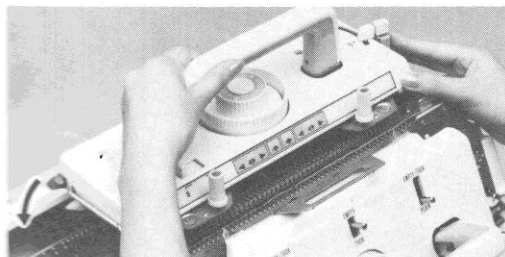

- 5 Pull forward carriage-release lever of main carriage.
At rib carriage side, set main carriage on to the bed from front rail and then back rail.
Set coupling.

CARRIAGE JAMMING IN PUNCH CARD KNITTING

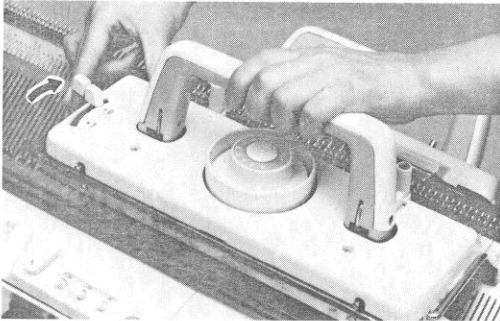

- 1 Remove Coupling.
- 2 Set both card levers to 0 and pull carriage-release lever towards you.
Remove main carriage from the bed.

- 3 Tilt rib carriage with front holders.
Slide it to the opposite side to knitting direction.

Set all stitches down to B position.

Unravel stitches carefully up to beginning of row on rib carriage side.

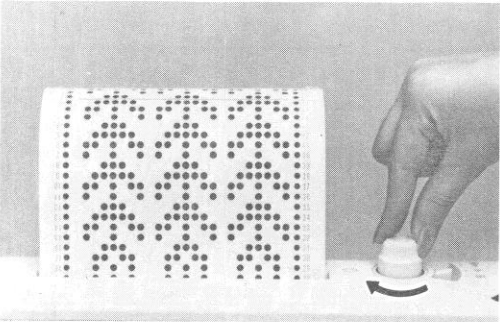

- 4 Turn punch card back for the number of rows unravelled plus one more row.

- 5 Set main carriage on the opposite side to rib carriage.

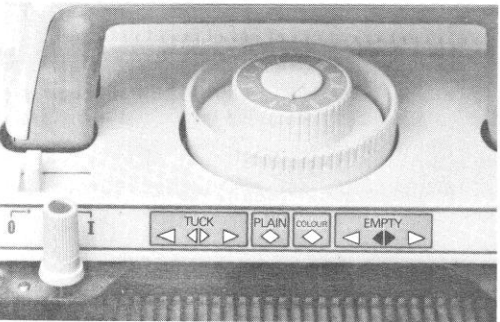

- 6 Set main carriage . . . EMPTY ◀▶
Card levers to C

Slide main carriage to Rib carriage.

The needles are selected.

Set Pattern dial to COLOUR ◀

Turn back row counter for the number of unraveled rows.

Re-set row counter lever.



- 7 Set Coupling.

Thread yarn into feeder.

Check there is no slack.

Recommence knitting.

HOW TO USE DOUBLE-EYED TRANSFER TOOL

(When transferring a stitch from one bed to the other.)

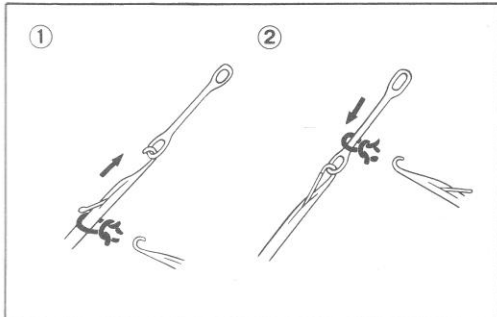

- 1 Pull the needle.
The latch will open and stitch will pass over latch.
- 2 Push needle back.
The stitch will be transferred to the tool.

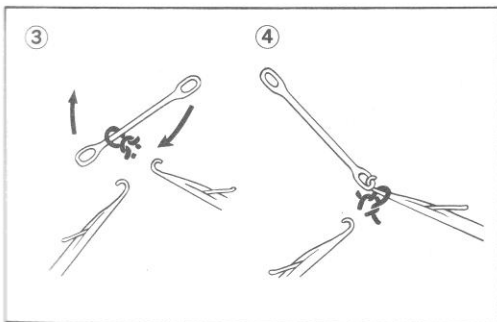

- 3 Tilt the tool and slip the stitch to the other end.
- 4 Hook the tool on to the needle on the other bed.
Slip the stitch down into needle hook.

DROPPED STITCHES

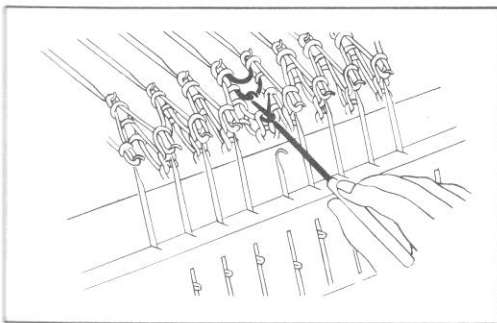

- 1 Remove knitting weights to prevent more stitches being dropped.

Loosen both thumb screws on main carriage and remove Coupling.

Drop ribber one step by pushing drop levers at both sides. (see p.50)

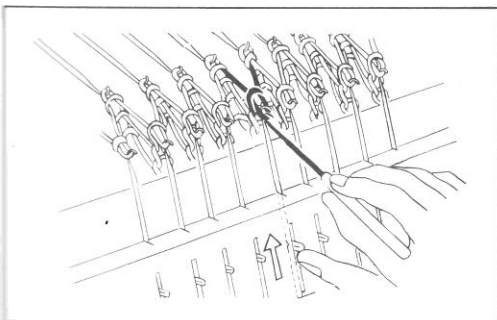

- 2 Insert the latch tool at the stitch 1 or 2 rows below the dropped stitch.
Push down latch tool.
When the needle on rib bed is dropped, insert the latch tool from outside to inside. When on main bed, insert it from inside to outside.
- 3 Catch the next loop and pull back latch tool.
Repeat it until last loop is knitted.
- 4 Put back the stitch to the empty needle.
The stitch is fixed.

HOW TO USE MAIN KNITTER AFTER RIBBING

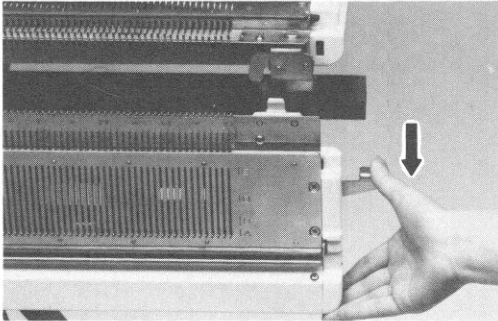

- 1 Using double-eyed transfer tool, transfer all stitches on ribber to main bed.
- 2 Remove coupling.
- 3 Remove rib carriage.
- 4 Push both drop levers by two steps down.

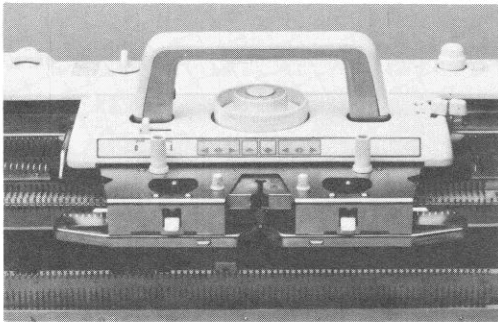

- 5 Secure fabric presser to main carriage.

Start knitting with single bed.

* In case of using LACE CARRIAGE, change the setting angle of main bed to level.

TENSION SWATCH

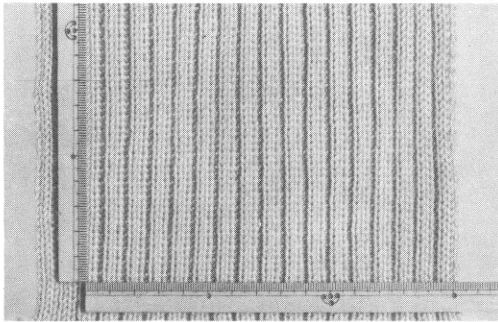

- 1 Cast on 60 stitches using garment yarn.
Knit 80 rows with the tension you have chosen.
- 2 Remove Tension Swatch from machine.
- 3 On the Flat board, stretch it in a horizontal direction considering the conditions to be worn as clothing, and pin it on a sheet of paper.
- 4 Count the stitches of knit and purl sides and rows in 10 sq. cm.

CHANGING NEEDLES

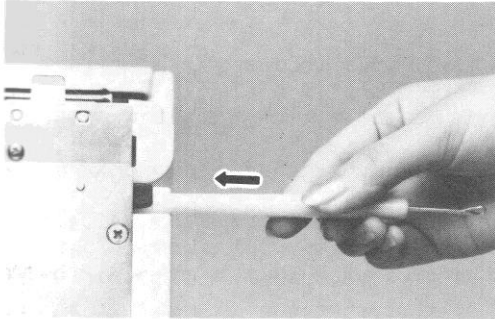

- 1 Push the bar with the butt of latch tool and pull it until the damaged needle is disengaged.

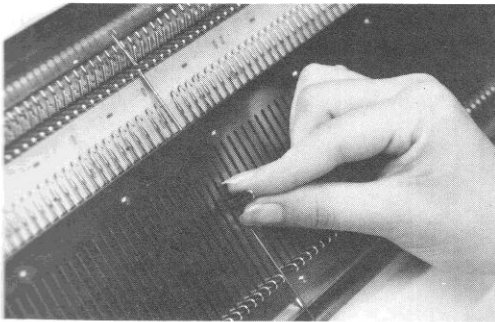

- 2 With latch closed, push up the needle, then pull it downwards.

Remove it by needle shank.

- 3 Insert the spare needle with the latch opened.

* Never put needles of Ribber to main bed.

- 4 Insert the bar pressing down the needles.

HOW TO USE SMALL WEIGHTS

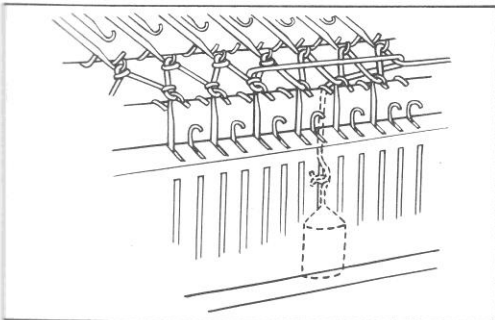

Hang weight hook over the edge stitches and hang small weight.

Re-hang weights every 10 or 15 rows.

In partial knitting, re-hang them after every 5 or 6 rows.

HOW TO USE YARN HOLDER SLOT

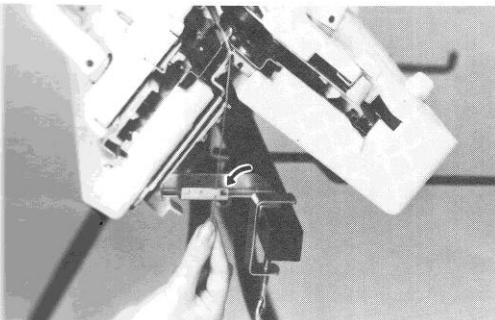

When yarn is changed or held over, hook yarn at yarn holder slot on outer side of fixing plate.

PROPER CARE OF THE MACHINE

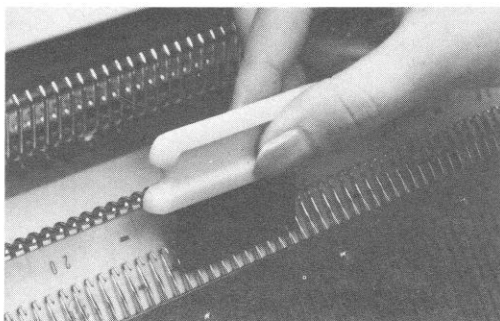

Cleaning

Never leave machine uncovered when not in use.

Clean the machine each time after knitting a garment.

Using small brush, dust the front edge of the needle bed on plastic film.

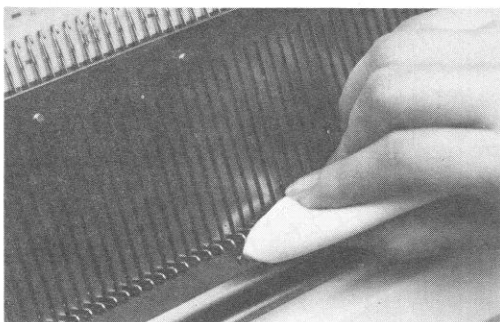

With a cloth or rag clean the rear rail of the needle bed, the front rail and the needle bed.

Oiling

Apply oil on a rag, then wipe needle butts and rails on beds.

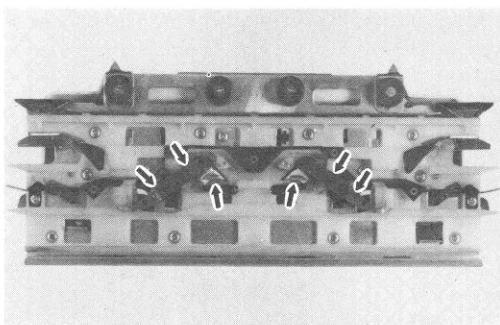

Take a clean cloth and rub the cams and parts under the carriage.

Put oil on a cloth and rub along both cams (arrowed) and rails under the carriage.
Wipe off the excess.

Store the machine in a cool and dry place.

MAKE YOUR GARMENTS BY SIMULKNIT

abbreviations

BYE = Bring yarn under the front E position needle
 cm = centimetres
 dec = decrease
 inc = increase
 K = Knit
 pos = position

RC = row counter
 st(s) = stitch(es)
 T. dial = tension dial
 2.2 = 2 . . that is . 2 . . 3
 1.1 = 1 . that is . 1 . . 2

notice

T. dials 2.1/4 means to set Main tension dial at 2.1 and Rib tension dial at 4.

To work larger sizes, follow figures in parentheses.

When only one set of figures is given, this applies to all sizes.

WAISTCOAT

SIZES To fit 83 (87, 98) cm bust
 Hereinafter referred to as A (B,C)

MATERIALS 3 ply wool
 Approx. 100g in col. 1 and 220 g
 in S yarn (col. 2)

PUNCH CARD No. 1014 (Optional card)

TENSION 31 sts and 46 rows in 10 cm.

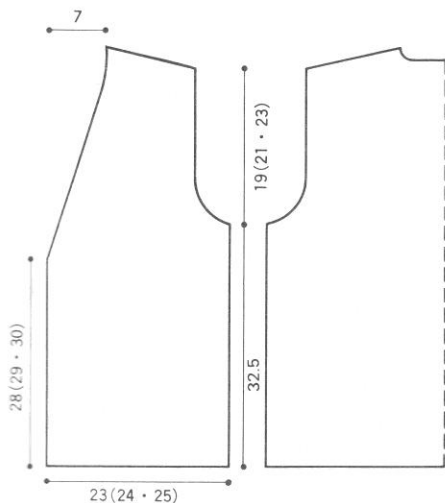

BACK:

Set 150 (156, 166) needles on main bed and 151 (157, 167) needles on ribber.

Cast on with col. 1. (1-8 on p. 29-30)

Insert punch card No. 1014. Set card stop lever to ■. Move carriages to right.

Set the tension for Simulknit and 3

Simulknit levers to S. Set RC at 000.

Reset card stop lever to ▼ and main carriage to COLOUR ◆. Thread S yarn (col. 2) Knit 146 rows.

SHAPE ARMHOLES:

At right cast off 3 sts. K 1 row.

At left cast off 3 sts. K 1 row.

* At right cast off 2 sts. K 1 row.

At left cast off 2 sts. K 1 row.*

- repeat twice.

** Dec 1 st both ends. K 2 rows.**

**-* repeat twice.

*** At right dec 1 st. K 1 row.

At left dec 1 st. K 3 rows.***

***-* repeat twice.

**** At right dec 1st. K 1 row.

At left dec 1 st. K 5 rows.****

****-* repeat 3 times for SIZE C only.

Dec 1 st both ends for SIZE A and B, K 2 rows.

K 52 (62, 54) rows. RC shows 232 (242, 250).

SHAPE SHOULDERS:

Set Partial knit levers to I on both main and rib carriages.

* At left bring 5 (6,6) needles to E pos.

K 1 row. BYE.

At right bring 5 (6,6) needles to E pos.

K 1 row. BYE.*

- repeat twice. RC shows 238 (248, 256).

SHAPE NECKLINE-RIGHT SIDE OF NECK

Carriage is at right. Make a note of row number of punch card. Bring 18 needles at right of machine centre on both beds, and ALL needles on left to E pos.

At right bring 5 (5,6) needles to E pos.

K 1 row. BYE.

At left bring 3 (3,3) needles to E pos.

K 1 row. BYE.

At right bring 5 (5,6) needles to E pos.

K 1 row. BYE.

At left bring 2 (2,2) needles to E pos.

K 1 row. BYE.

At right bring 5 (5,6) needles to E pos.



K 1 row. BYE.

K 1 row. RC shows 245 (255, 263). At right bring 24 th needle and ALL to right of it to B pos. K 1 row. RC shows 246 (256, 264). Set card levers to 0, and 3 Simulknit levers to 0. Thread two waste yarns, work some waste knitting, and remove the right side of neck from machine. Push back empty needles to A pos.

LEFT SIDE OF NECK:

Set both carriages to EMPTY.

Slide carriages to left. Partial knit levers are still set to I. Reset RC to 238 (248, 256). 21st to 39th needles from left end are set at B pos. All other needles on main bed are at E pos. All needles on rib bed are at E pos.

Set main carriage to EMPTY  and card levers to C. Turn back punch card to the number noted before. Set card stop lever to . Move carriages to right and re-set card stop lever to , and 3 Simulknit levers to S. Push required needles to be knitted to D pos on rib bed. Thread col. 1 and S yarn. K 1 row to left.

At right bring 3 (3, 3) needles to E pos. K 1 row. BYE.

At left bring 5 (5, 6) needles to E pos.

K 1 row. BYE.

At right bring 2 (2, 2) needles to E pos.

K 1 row. BYE.

At left bring 5 (5, 6) needles to E pos.

K 1 row. BYE.

K 1 row. Bring 24th needle on left of machine centre and ALL on left of it to B pos.

K 1 row. RC shows 245 (255, 263).

Set main carriage to PLAIN , and Card levers to 0, and partial knit levers to 0.

Thread two waste yarns. Do some waste knitting, and remove the part from machine.

Push back empty needles to A pos. Carriages are at left. Bring needles to B pos on main bed. Transfer all sts on ribber to main bed.

Remove S yarn from feeder. Set tension dial 3-5 numbers looser, and K 1 row to right.

Cast off stitches with method of "Big Loops" or "Bind off".

LEFT FRONT:

Set 75 (78, 83) needles on main bed from the centre of machine to left. Set 76 (79, 84) needles on ribber. Cast on with col. 1.

Insert punch card and set carriages for Simulknit with correct tensions.

Select needles and thread S yarn. (page 29-30)

Set RC at 000. Bring the edge needle at Right on main bed. K 129 (133, 135) rows.

SHAPE FRONT SLOPE:

Dec 1 st at right.

Knit until 146 (146, 146)th row decreasing 1 st at right every 5th row.

SHAPE ARMHOLE:

Decrease 1 st at right every 5th row, and at the same time shape armhole at left as follows.

Cast off 5 sts, K 2 rows. Cast off 3 sts, K 2 rows.

Cast off 2 sts. K 2 rows.

* Dec 1 st, K 2 rows.* *-* repeat once.

** Dec 1 st. K 4 rows.** *-** repeat 1 (1, 3) times.

Dec 1 st K 66 (76, 76). RC shows 232 (242, 250) rows.

SHAPE SHOULDER:

Set partial knit levers to I on both main and rib carriages. At left bring 5 (6, 6) needles to E pos. Knit 1 row. BYE. K 1 row.

* At left bring 5 (6, 6) needles to E pos.

K 1 row. BYE. K 1 row.*

- repeat once.

** At left bring 5 (5, 6) needles to E pos.

K 1 row. BYE. K 1 row.**

*** repeat twice.

Release partial knit levers to 0.

RC shows 245 (255, 263).

Set main carriage to PLAIN  and Card levers to 0 and Simulknit levers to 0.

Thread two waste yarns. Do some waste knitting and remove it from machine.

RIGHT FRONT:

Work as for left front with all the shapings reversed.

MAKE UP:

Pin out pieces and press lightly.

Sew shoulder seams and side seams.

FULL-LENGTH SKIRT

SIZES	To fit 92 (96, 100) cm hip and 66 (70, 74) cm waist. Finished length is 97 (102, 107) cm.
MATERIAL	3 ply wool Approx. 520 g in col. 1 and 600 g in S yarn.
PUNCH CARD	No. 1019 (Optional card)
TENSION	31 sts and 46 rows in 10 cm. (when T. dials set at 3/4.2)

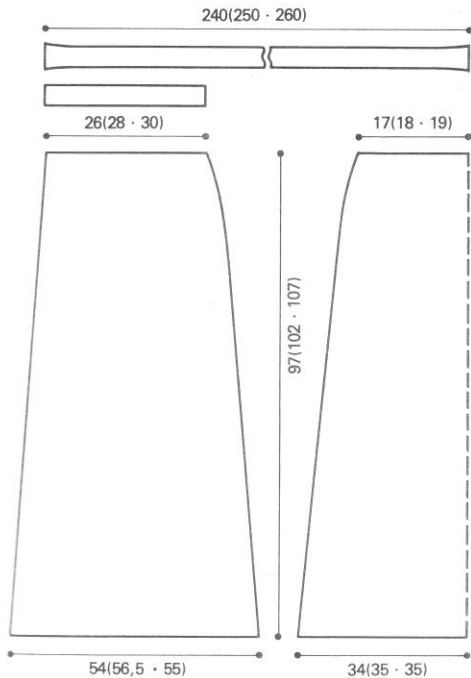

Make one panel of BACK and two panels of FRONT. The lower part of each panel is shaped by changing the setting of tension dials.

BACK:

Set 95 (99, 99) needles on both sides of centre on main bed, and 96 (100, 100) needles on rib bed.

*Cast on with col. 1. (1-8 on p. 29-30)

Set RC at 000, T. dials 3.2/3.2 K 6 rows of close rib. Insert punch card No. 1019 and machine for Simulknit.

Thread S yarn.

T. dials 5/6.2 K 28 rows.

T. dials 4.2/6.1 K 28 rows.

T. dials 4.1/6 K 28 rows.

T. dials 4/5.2 K 28 rows.

T. dials 3.2/5.1 K 28 rows.

T. dials 3.1/5 K 28 rows.

RC shows 174. Set T. dials 3/4.2.

Dec. 1 st on both beds on 174th row.

K 10 (10, 13) rows and dec 1 st on both beds and repeat 9 (21, 6) times.

K 9 (14, 12) rows, and dec 1 st, and repeat 10 (0, 11) times.*

**K 10 (11, 13) rows, dec 1 st. K 8 (9, 12) rows, dec 1 st, and repeat 1 (0, 1) time.

K 6 (6, 8) rows, dec 1 st, and repeat 2 (1, 0) times.

K 5 rows, dec 1 st, and repeat 2 (1, 1) times.

K 4 rows, dec 1 st, and repeat 3 (3, 6) times.

For SIZE B only, K 3 rows dec 1 st, and repeat once. RC shows 448 (472, 492).

Set carriages all for PLAIN.**

On both main and rib beds, transfer 9 sts, listed below, to the inside adjacent needle at each right and left side to gather for waist.

SIZES A - 27th, 29th, 31st, 33rd, 35th, 37th, 39th, 41st, and 43rd sts from machine centre.

SIZE B - 29th, 31st, 33rd, 35th, 37th, 39th, 41st, 43rd, and 45th sts from machine centre.

SIZE C - 31st, 33rd, 35th, 37th, 39th, 41st, 43rd, 45th, and 47th sts from machine centre.

Do some waste knitting and remove the piece from the machine.

LEFT FRONT:

Set 149 (157, 161) needles on main bed and 150 (158, 162) needles on ribber.

For decreasing sts at right end use double eyed transfer tool. Knit as for BACK *-*.

Bring the edge needle at Right on main bed to D pos every row.

RC shows 373 (394, 409). At left end work as for BACK **-**, at the same time shape the right edge as follows:

K 13 (13, 9) rows, dec 1 st, repeat 2 (4, 2) times.

K 12 (0, 8) rows, dec 1 st, repeat 1 (0, 5) times.

On the left side of machine centre on both beds, transfer 9 sts, listed below, to the adjacent needle on right.

SIZE A - 27th, 29th, 31st, 33rd, 35th, 37th, 39th, 41st, and 43rd sts from centre.

SIZE B - 29th, 31st, 33rd, 35th, 37th, 39th, 41st, 43rd, and 45th sts from centre.

SIZE C - 31st, 33rd, 35th, 37th, 39th, 41st, 43rd, 45th, and 47th sts from centre.

Do some waste knitting and remove the piece from the machine.

RIGHT FRONT:

Knit as for LEFT FRONT but reversing all shapings.

BANDS:

Knit two bands, long and short.

Long Band:

*Cast on as close rib, see page 17.

Use yarn in 2 strands, threading two yarns through each right and left upper tension unit and into col. 1 yarn feeder together.

Set 14 needles on main bed and 15 needles on ribber.

After casting on, transfer the 2nd end needles on ribber on both edges, to adjacent needle and bring back the empty needle to A pos.*

Set T. dials 9 on both carriages. K 50 rows.

T. dials 8. K 50 rows.
 T. dials 7. K 50 rows.
 T. dials 6. K 50 rows.
 T. dials 5. K 50 rows.
 T. dials 4. K 37 (50, 64) rows.

Mark around the RIGHT end st with a piece of waste yarn.

K 120 (128, 138) rows. Mark around the RIGHT end st.

K 156 (165, 174) rows. Mark around the RIGHT end st.

K 77 (91, 105) rows.

T. dials 5. K 54 rows.

T. dials 6. K 54 rows.

T. dials 7. K 54 rows.

T. dials 8. K 54 rows.

T. dials 9. K 54 rows.

RC shows 910 (954, 001). Cast off.

Short Band:

Cast on as *-* of long band.

T. dials 4. K 120 (128, 138) rows.

Cast off.

MAKE UP:

Pin out and press the pieces.

Seam right and left sides.

Hold LEFT FRONT panel of seamed garment with right side facing you.

Pick up sts of last row knitted in col. 1 and S yarn onto needles. Push them behind latches. Holding short band wrong side facing you, match the marks and pick up two loops of last row onto the needles. Push all needles to B pos. The loops in needle hook are knitted by the other two loops.

K 1 row with large tension.

Cast off using latch tool.

Hold the garment right side facing you, and pick up sts of BACK and RIGHT FRONT onto needles. Push them behind latches.

Hold long band with wrong side facing you, and pick up sts onto needles, starting from the 1st marked st with waste yarn to 3rd marked st.

Be sure that marked 2nd st is fit to right seam of garment and marked 3rd st is to left seam.

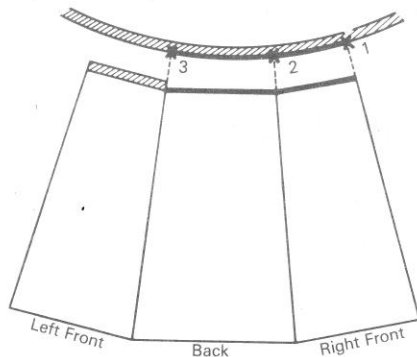

Push back needles to B pos and the loops in needle hooks are knitted by the other two loops. K 1 row with large tension.

Cast off using latch tool.

At left side seam, catch together short and long bands.

SHOULDER BAG

SIZES approx. 23cm wide and 24cm long.

MATERIALS 4 ply wool
 approx. 100g in col. 1 (red)
 70g in col. 2 (green), 40g in col. 3 (yellow)

PUNCH CARD No. 5

TENSION 30 sts and 39 rows in 10cm
 (when T. dials set at 4.2/6.1)

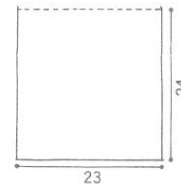

MAIN PART in one piece:

Set 72 needles on main bed and 73 needles on rib bed. Cast on with col. 1 (1-8 on p. 29-30).

Insert punch card No. 5. Set card stop lever to ■.

Move carriages to right. Set the tension dials at 4.2/6.1 and 3 Simulknit levers to S. Set RC at 000. Reset card stop lever to ▼ and main carriage to COLOUR ◆. Thread col.2.

Knit 20 rows, bringing the edge needles on both sides of main bed every row.

K 18 rows with col. 3

K 42 rows with col. 2.

K 9 rows with col. 3.

Release card levers to 0. K 6 rows.

Reset card levers to C. K 9 rows with col. 3.

K 42 rows with col. 2.

K 18 rows with col. 3.

K 22 rows with col. 2.

Transfer all sts on ribber to main bed.

Set main carriage for plain knitting. K 1 row with larger tension. Cast off using latch tool.

MAKE UP:

Pin out and press the piece. Fold the piece in two and seam sides. Sew yarn ends through fabric.

STRAP:

Take 16 strands of col. 1 in 2.5 metres.

Make a plait, leaving ends free. Knot and cut them to equal length so as to form a tassel.

Sew strap on to sides of bag.

GUIDE TO TENSION DIAL AND YARN

e. g. $\frac{1}{0} \dots \frac{\text{Main Tension Dial}}{\text{Rib Tension Dial}}$

(Names of the kinds of yarn will vary in each country.)

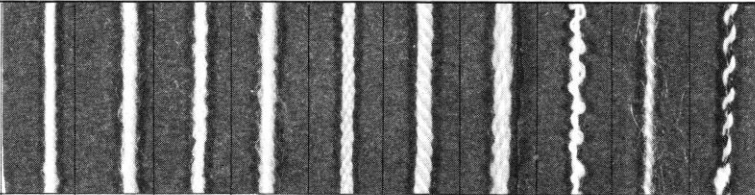
Kinds of Yarns (In live size)												
Names		Fine medium 3ply	Medium 4ply	Thick 2ply	Thick 3ply	Crepe 5(4)ply	6ply	Crepe 8ply	Boucle	Mohair	Tweed	
① 1x1 Rib	Cast on (1st threading)	$\frac{0}{0}$	$\frac{0}{0}$	$\frac{0}{0}$	$\frac{0}{0}$	$\frac{0}{0}$	$\frac{1}{1}$	$\frac{3}{3}$	$\frac{0}{0}$	$\frac{0}{0}$	$\frac{0}{0}$	
	Cast on (3 rows of knitting)	2nd row	$\frac{1}{0}$	$\frac{2}{0}$	$\frac{2}{0}$	$\frac{2}{0}$	$\frac{3}{0}$	$\frac{6}{1}$	$\frac{8}{3}$	$\frac{3}{0}$	$\frac{2}{0}$	$\frac{3}{0}$
		3rd and 4th rows	$\frac{1}{1}$	$\frac{2}{2}$	$\frac{2}{2}$	$\frac{2}{2}$	$\frac{3}{3}$	$\frac{6}{6}$	$\frac{8}{8}$	$\frac{3}{3}$	$\frac{2}{2}$	$\frac{3}{3}$
	Ribbing	$\frac{1}{1}$	$\frac{2}{2}$	$\frac{2}{2}$	$\frac{2}{2}$	$\frac{3}{3}$	$\frac{6}{6}$	$\frac{8}{8}$	$\frac{3}{3}$	$\frac{2}{2}$	$\frac{3}{3}$	
② Skinny Rib (2x2 Rib) (Tighter Rib)	Cast on (1st threading)	$\frac{0}{0}$	$\frac{2}{2}$	$\frac{1}{1}$	$\frac{1}{1}$	$\frac{2}{2}$	$\frac{3}{3}$	$\frac{3}{3}$	$\frac{1}{1}$	$\frac{1}{1}$	$\frac{2}{2}$	
	Cast on (3 rows of knitting)	2nd row	$\frac{2}{0}$	$\frac{4}{2}$	$\frac{4}{1}$	$\frac{4}{1}$	$\frac{5}{2}$	$\frac{7}{3}$	$\frac{8}{3}$	$\frac{5}{1}$	$\frac{4}{1}$	$\frac{5}{2}$
		3rd and 4th rows	$\frac{2}{2}$	$\frac{4}{4}$	$\frac{4}{4}$	$\frac{4}{4}$	$\frac{5}{5}$	$\frac{7}{7}$	$\frac{8}{8}$	$\frac{5}{5}$	$\frac{4}{4}$	$\frac{5}{5}$
	Ribbing	$\frac{2}{2}$	$\frac{4}{4}$	$\frac{4}{4}$	$\frac{4}{4}$	$\frac{5}{5}$	$\frac{7}{7}$	$\frac{8}{8}$	$\frac{5}{5}$	$\frac{4}{4}$	$\frac{5}{5}$	
③ Close Rib	Cast on (1st threading)	$\frac{0}{0}$	$\frac{1}{1}$	$\frac{1}{1}$	$\frac{1}{1}$	$\frac{1}{1}$	—	—	—	$\frac{1}{1}$	—	
	Cast on	2nd row	$\frac{2}{0}$	$\frac{4}{1}$	$\frac{4}{1}$	$\frac{4}{1}$	$\frac{5}{1}$	—	—	—	$\frac{5}{1}$	—
		3rd and 4th rows	$\frac{2}{2}$	$\frac{4}{4}$	$\frac{4}{4}$	$\frac{4}{4}$	$\frac{5}{5}$	—	—	—	$\frac{5}{5}$	—
	Ribbing	$\frac{2}{2}$	$\frac{4}{4}$	$\frac{4}{4}$	$\frac{4}{4}$	$\frac{5}{5}$	—	—	—	$\frac{5}{5}$	—	
④ Circular Knitting	$\frac{4}{4.2}$	$\frac{5}{5.2}$	$\frac{5}{5.2}$	$\frac{5}{5.2}$	$\frac{6}{6.2}$	$\frac{7}{7.2}$	$\frac{8}{8.2}$	$\frac{6}{6.2}$	$\frac{5}{5.2}$	$\frac{6}{6.2}$		

* When knitting with thicker yarn than 8ply, use alternate needles.



AISIN SEIKI CO., LTD.

3140909-111-C

ENGLISH

PRINTED IN JAPAN

